

This manual is available for repair in the Europe, England, Australia and Russia markets. Please refer to the original manual (B51-5419-00) if need the information in the USA and Canada and other markets.

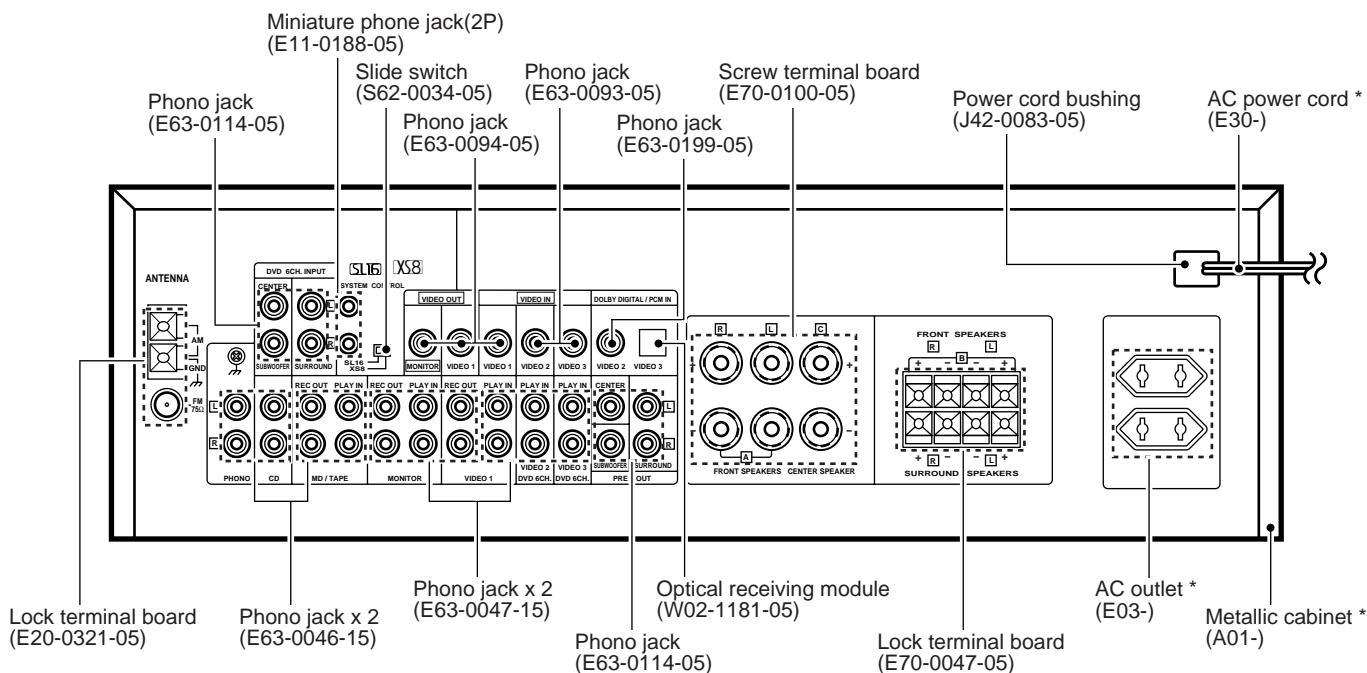
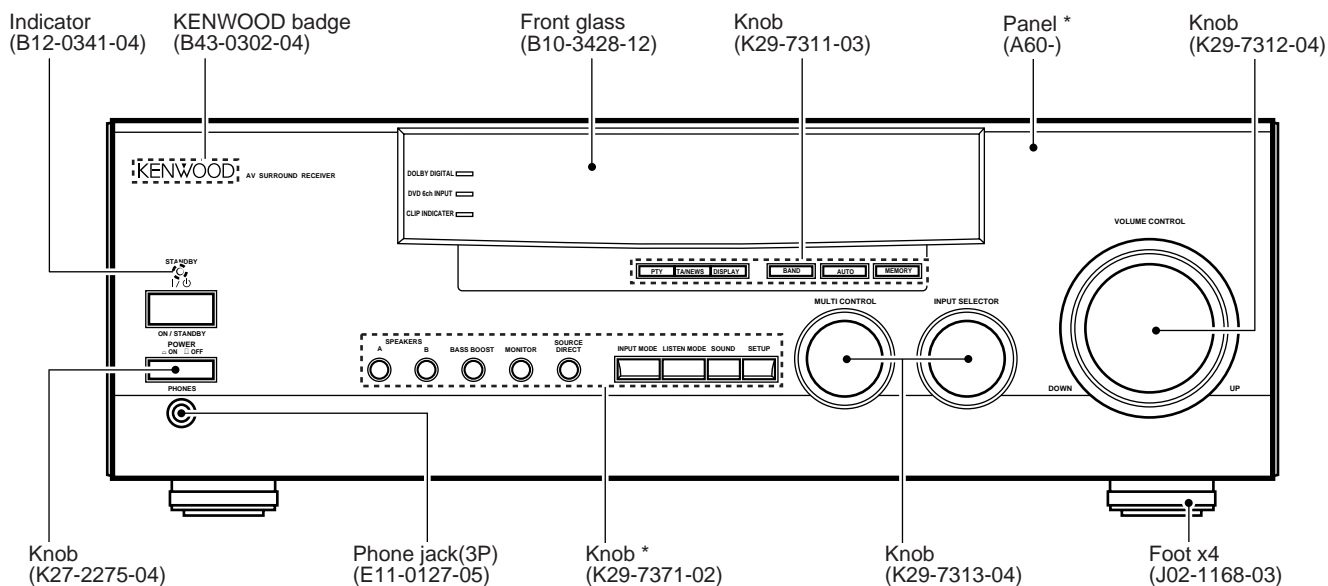

KRF-V8010D/V8010DW

CONTENTS / ACCESSORIES / CAUTIONS

Contents

CONTENTS / ACCESSORIES / CAUTIONS.....	2	PARTS DESCRIPTIONS	11
CONTROLS	3	PC BOARD	12
DISASSEMBLY FOR REPAIR.....	5	SCHEMATIC DIAGRAM	17
BLOCK DIAGRAM	6	EXPLODED VIEW	30
CIRCUIT DESCRIPTION.....	7	PARTS LIST.....	31
ADJUSTMENT	10	SPECIFICATIONS	40

Please refer to KRF-V5010 (B51-5425-00) and KRF-V7510D (B51-5419-00) service manuals if need the information on circuit description.

Accessories

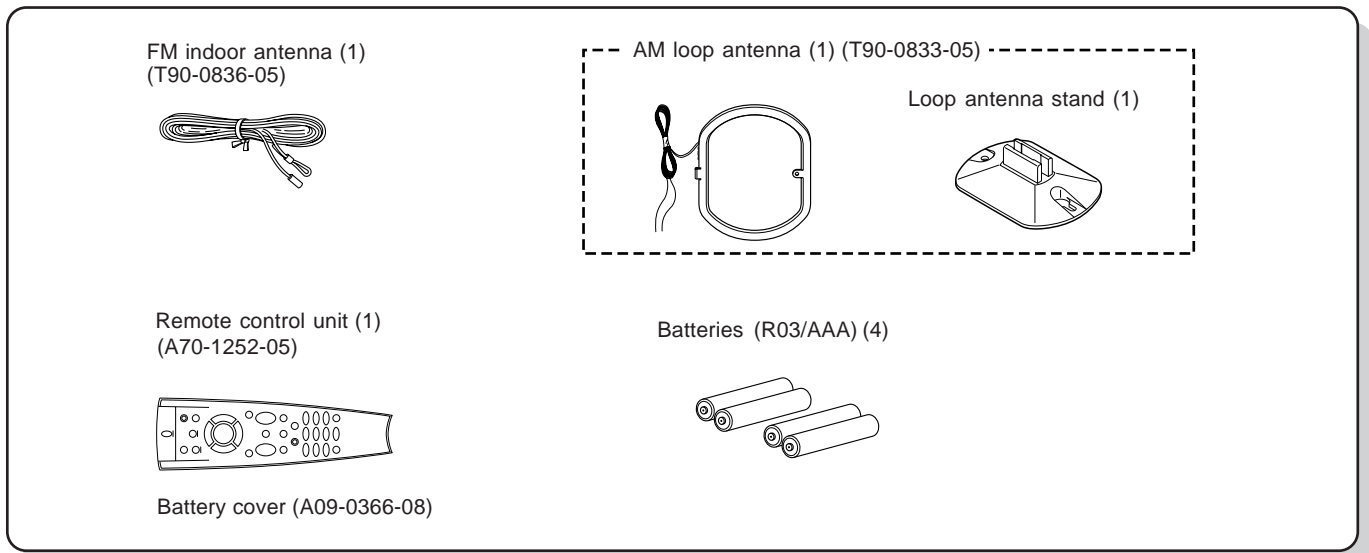

Cautions

Resetting the Microcomputer

If the microcomputer may malfunction (unit cannot be operated, or shows an erroneous display) if the power cord is unplugged while the power is ON, or due to some other external factor. If this happens, execute the following procedure to reset the microcomputer and return the unit to its normal operating condition.

With the power cord plugged in, turn the POWER key OFF. Then, while holding down the ON/STANDBY key, press POWER.

- Please note that resetting the microcomputer will clear the contents of the memory and returns the unit to the state it was in when it left the factory.

CONTROLS

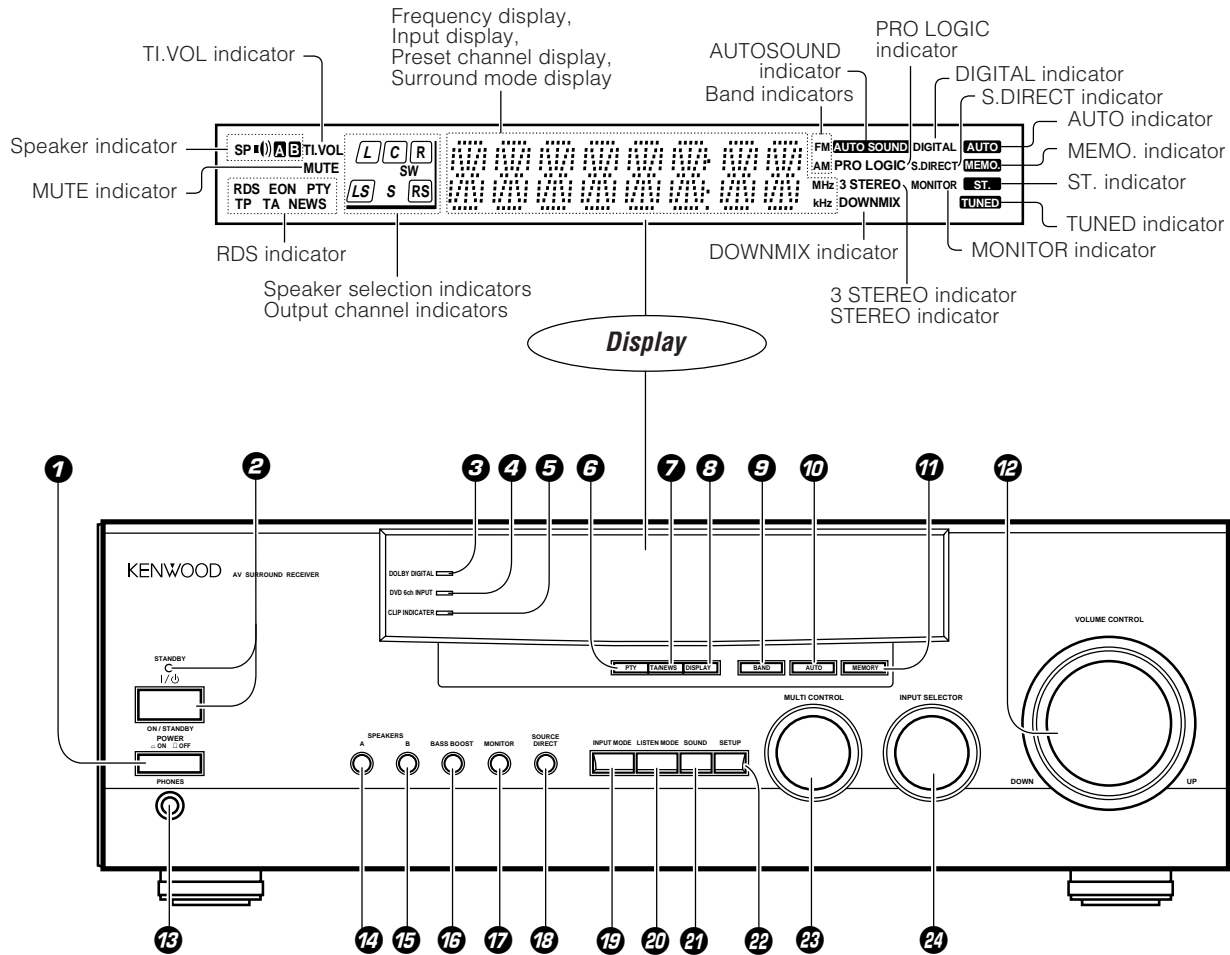

- 1 POWER key**
Use to turn the main power ON/OFF.
- 2 ON/STANDBY (1/φ) key**
Use to switch the power ON/STANDBY when the POWER is turned ON.
STANDBY indicator
- 3 DOLBY DIGITAL indicator**
Lights when the receiver is in the Dolby Digital mode.
- 4 DVD 6ch INPUT indicator**
Lights when the receiver is in the DVD 6ch INPUT mode.
- 5 CLIP INDICATOR indicator**
Lights when the input signal is too large to be handled by the receiver, and "clipping" is occurring.
- 6 PTY key**
Use to perform PTY search.
- 7 TA/NEWS key**
- 8 DISPLAY key**
Use to change the display indications when receiving RDS broadcasts.
- 9 BAND key**
Use to select the broadcast band.
- 10 AUTO key**
Use to select the auto tuning mode
- 11 MEMORY key**
Use to store radio stations in the preset memory.
- 12 VOLUME CONTROL knob**
- 13 PHONES jack**
Use for headphone listening.
- 14 SPEAKERS A key**
Use to turn speaker system A on and off.
- 15 SPEAKERS B key**
Use to turn speaker system B on and off.
- 16 BASS BOOST key**
Use to select the maximum adjustment setting for the low frequency range.
- 17 MONITOR key**
- 18 SOURCE DIRECT key**
- 19 INPUT MODE key**
Use to switch between the digital and analog inputs.
- 20 LISTEN MODE key**
Use to select the listening mode.
- 21 SOUND key**
Use to adjust the sound quality and ambience effects.
- 22 SETUP key**
Use to select the surround sound settings.
- 23 MULTI CONTROL knob**
Used to make a variety of settings.
- 24 INPUT SELECTOR knob**
Use to select the input sources.

About the STANDBY indicator

This unit has a STANDBY indicator. When the STANDBY indicator is lit, the unit consumes a small amount of power to preserve the memory. This is called STANDBY mode. This mode also lets you turn the power ON using the remote control.

CONTROLS

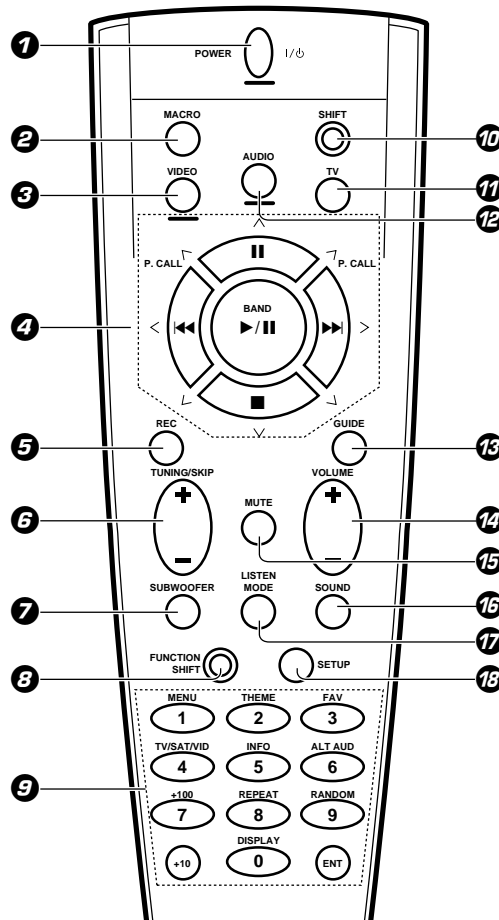

There are some cases in which keys (or knobs) that have the same function on the receiver and on the remote control have different names. In the instructions of this manual, if the names of corresponding keys (or knobs) on the receiver and remote control are different, the name of the remote control key is indicated in parentheses).

1 POWER key

Use to turn the receiver on and off. Use in combination with the input selector (AUDIO, VIDEO, or TV) keys and SHIFT key to turn various components on and off.

2 MACRO key

Use in combination with the AUDIO, VIDEO, or TV keys to execute a series of commands automatically (MACRO PLAY).

3 VIDEO selector key

Selects the video inputs and sets the remote control to operate the component registered at the respective input.

4 Multi control keys

Use to operate the selected component.

5 REC key

Use to operate the selected component.

6 TUNING/SKIP key

Use during the setup procedure to specify various settings. Use to operate the tuner or selected component.

7 SUBWOOFER key

Use in combination with the VOLUME +/- keys to adjust the volume of the subwoofer.

8 FUNCTION SHIFT key

Use in combination with the numeric keys to execute alternate commands.

9 Numeric keys

Provide functions identical to those of the original remote control supplied with the component you are controlling. To access the functions printed above the keys, press within 3 seconds of pressing the FUNCTION SHIFT key. Function availability varies for each component.

10 SHIFT key

Use in combination with the AUDIO and VIDEO keys to change the remote control mode without changing the input selector or in combination with the POWER key to turn on and off components programmed into the remote control.

11 TV selector key

Sets the remote control to operate a TV or cable box. This key does not change the input selector on the receiver.

12 AUDIO selector key

Selects the audio inputs and sets the remote control to operate the respective KENWOOD audio component.

If you connect audio components from KENWOOD and other makers to the MD/TAPE or CD jacks, you can set the remote control to operate these components by registering the appropriate setup code at the respective input.

13 GUIDE key

Use to activate the OSD menu functions of registered components.

14 VOLUME key

Use to adjust the receiver volume.

15 MUTE key

Use to temporarily mute the sound.

16 SOUND key

Use to adjust the sound quality and ambience effects.

17 LISTEN MODE key

Use to select the listening mode.

18 SETUP key

Use to select the surround sound settings.

KRF-V8010D/V8010DW

DISASSEMBLY FOR REPAIR

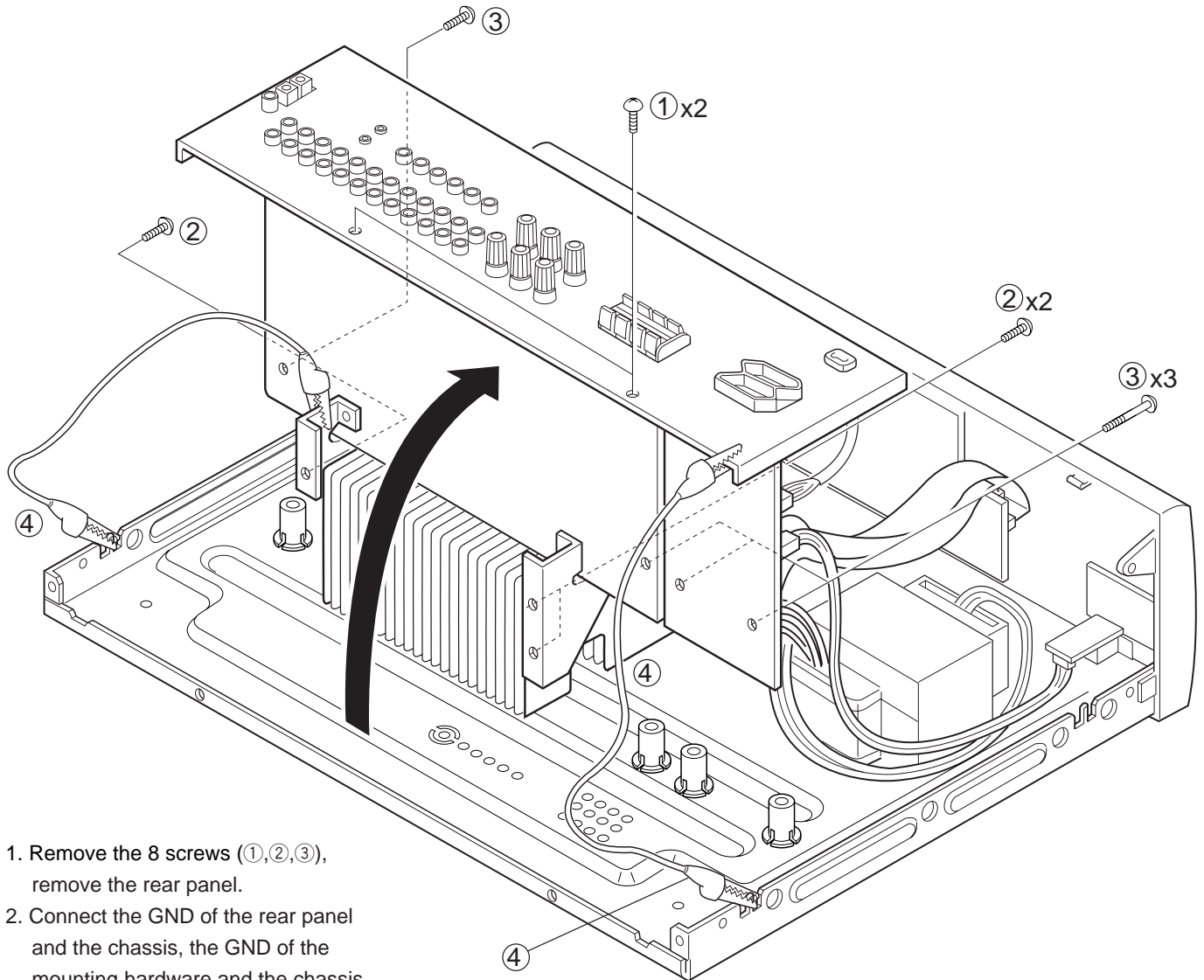

1. Remove the 8 screws (①,②,③), remove the rear panel.
2. Connect the GND of the rear panel and the chassis, the GND of the mounting hardware and the chassis with 2 alligators clip (④)

KRF-V8010D/V8010DW

BLOCK DIAGRAM

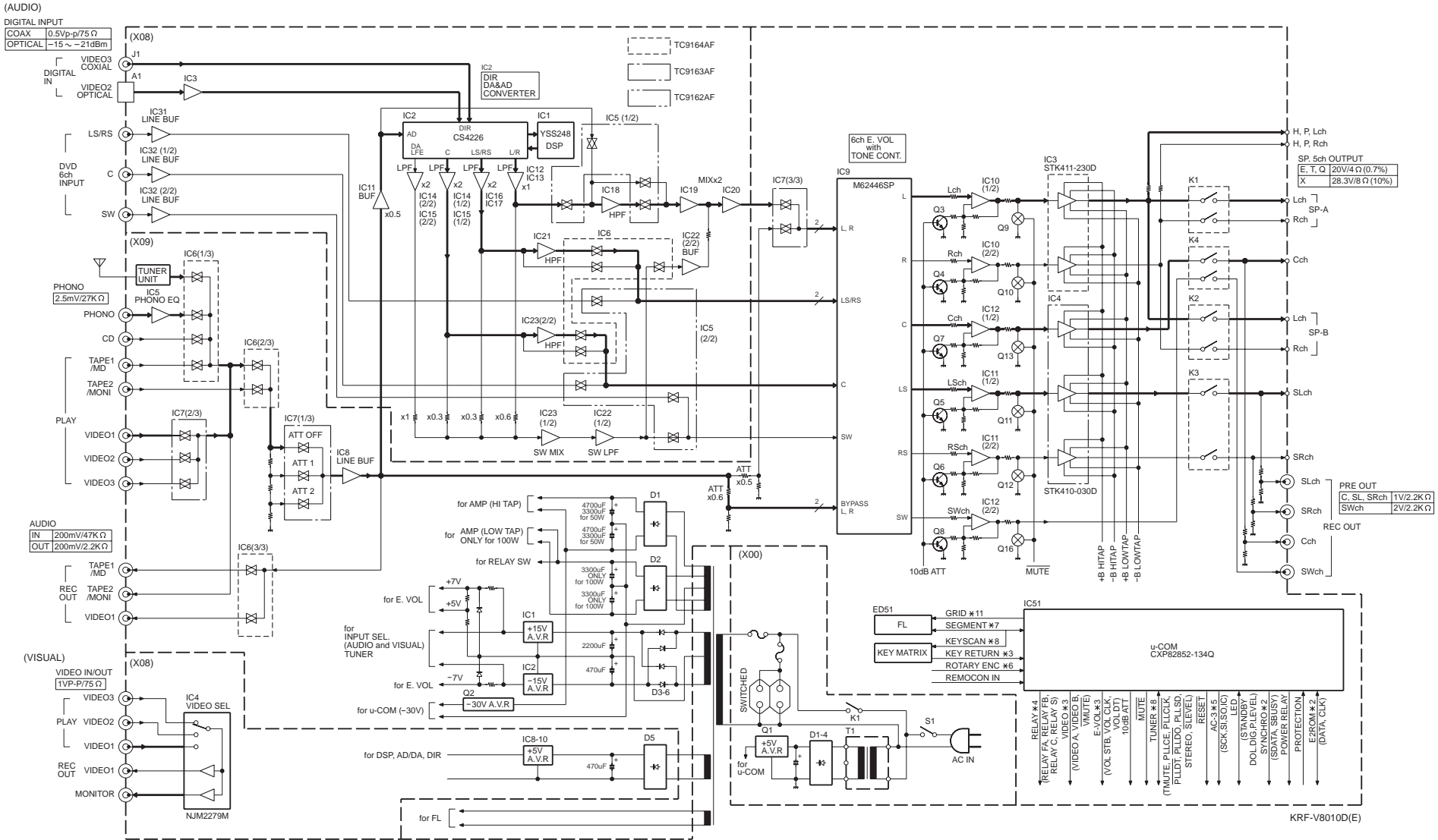

KRF-V8010D(E)

KRF-V8010D/V8010DW

CIRCUIT DESCRIPTION

1. Microprocessor: CXP82832-134Q(X09 : IC51)

1-1 Microprocessor periphery block diagram

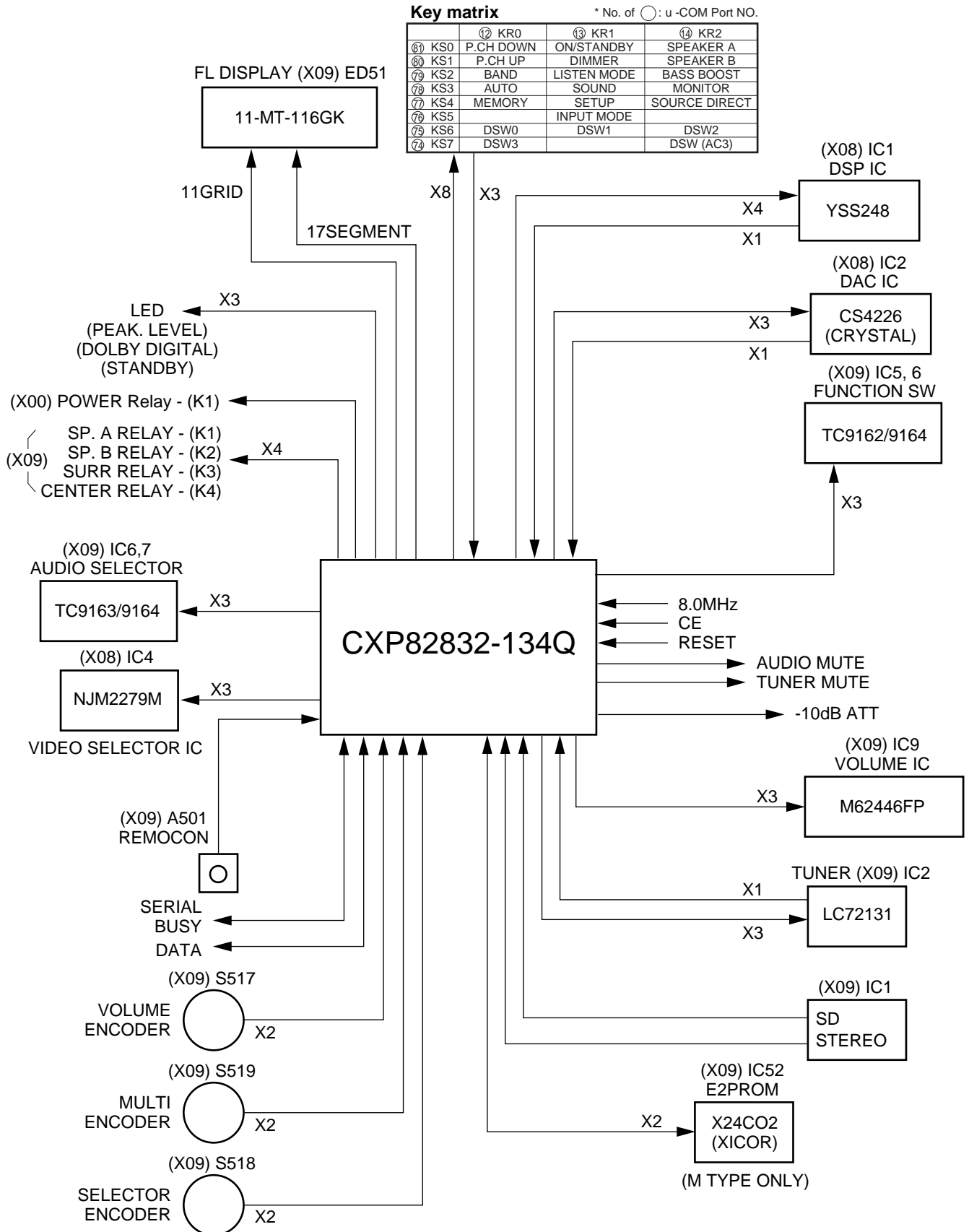

KRF-V8010D/V8010DW

CIRCUIT DESCRIPTION

1-2 Pin description

Pin No.	Pin Name	I/O	Description
1,2	G10,11	O	Display grids 10,11
3	None	-	Ic test mode port.
4	CK	I	RDS clock input.
5	RDS. DT	I	RDS data input.
6	AUDIO	I	Audio signal detection port. L=AUDIO.
7	VOL.ENC.A	I	Volume encoder A(clockwise) input.
8	REMOCON	I	Remote control signal input.
9	VOL.ENC.B	I	Volume encoder B(counterclockwise) input.
10,11	None	O	Ic test mode port.
12-14	KR0-2	I	Key return 0-2.
15	PROTECT	I	Protection signal detection port. H=PROTECT.
16	S.DATA	I/O	Serial DATA signal.
17	S.BUSY	I/O	Serial BUSY signal.
18	E2.DT	I/O	E2 PROM data.
19	E2.CLK	I/O	E2 PROM clock.
20	SEL.ENC.A	I	Selector encoder A(clockwise) input.
21	SEL.ENC.B	I	Selector encoder B(counterclockwise) input.
22	MULTI.ENC.A	I	Multi encoder A(clockwise) input.
23	MULTI.ENC.B	I	Multi encoder B(counterclockwise) input.
24	AC3	I	AC-3 signal detection.
25	AC3.SCK	O	YSS248 clock output.
26	AC3.SI	I	YSS248 data input.
27	AS3.SO	O	YSS248 data output.
28	Vdd	-	Analog power supply(+5V)
29	S. LEVEL	I	Signal level A/D input.
30	SEL.ST2	O	TC9162AF/63AF/64AF st2 output. H=latch.
31	AC3.CS	O	YSS248 CS output.
32	CODEC.CS	O	CS4226 CS output.
33	PLL.DO	I	PLL ic do signal input port.
34	PLL.ST	I	Tuner stereo signal detection port. L=STEREO.
35	PLL.SD	I	Tuner sd signal detection port. L=TUNED.
36	RCV.CE	I	Receiver chip enable signal port. L=ENABLE.
37	Avss	-	Analog GND.
38	RESET	I	Microprocessor reset signal.
39,40	8MHz	I	Main clock generation(8MHz).
41	Vss	-	Microprocessor GND.
42	None	I	No connect
43	TEX	-	GND.
44	Vdd	-	Power supply(+5V).
45	Vfdp	-	Power supply(-33V).
46	SEL.ST1	O	TC9162AF/63AF/64AF st1 output. H=latch.
47	PLL.DT	O	PLL ic data signal output.
48	PLL.CK	O	PLL ic clock signal output.
49	PLL.CE	O	PLL ic ce signal output port.
50	T.TUNE	O	Tuner mute control. L=mute on.
51	A.MUTE	O	Output mute control. L=mute on.
52	SW.MUTE	O	Sub woofer mute control. L=mute on.
53	10dB.ATT	O	Volume 10dB attenuation control. H=att. on.
54	VOL.DT	O	Volume ic (M62446SP) data control.
55	VOL.CK	O	Volume ic (M62447SP) clock control. H=active.

KRF-V8010D/V8010DW

CIRCUIT DESCRIPTION

Pin No.	Pin Name	I/O	Description
56	VOL.ST	O	Volume ic (M62448SP) st control. H=active.
57	VCR.MUTE	O	Video ic (NJU2279D) cont2/4 mute control. L=mute on.
58	VCR.A	O	Video ic (NJU2279D) cont1 mute control. H/L=static.
59	VCR.B	O	Video ic (NJU2279D) cont3 mute control. H/L=static.
60	FA.RLY	O	Front A speaker relay control. H=relay on.
61	FB.RLY	O	Front B speaker relay control. H=relay on.
62	C.RLY	O	Center speaker relay control. H=relay on.
63	S.RLY	O	Rear speaker relay control. H=relay on.
64	POWER.RLY	O	Power relay control. H=relay on.
65	STANDBY.LED	O	Standby led control.L=led on.
66	DOL.DIG.LED	O	Dolby digital led control.L=led on.
67	CLIP INDI. LED	O	Clip indicator led control.L=led on.
68	DVD 6CH LED	O	DVD 6CH input level control.
69-70	None	O	No connect
71	PACL_CTL	O	Non oscillation of power pack ic at power off. L=stop oscillation.
72	AC3.IC	O	YSS248/CS4226 initial clear port.
73	EMPHASIS	O	Tuner emphasis on/off. H=100k/10k,L=50k/9k.
74-81	P1-8	O	Display segments 1-8 & key returns 0-7.
82-88	P9-15	O	Display segments 9-15.
89	Vdd	O	Microprocessor power supply(+5V)
90,91	P16,17	O	Display segments 16,17
92-100	G1-9	O	Display grids 1-9.

KRF-V8010D/V8010DW

ADJUSTMENT

No.	ITEM	INPUT SETTINGS	OUTPUT SETTINGS	TUNER SETTINGS	ALIGNMENT POINTS	ALIGN FOR	FIG.
FM SECTION SELECTOR : FM ※ Adjust NO.1 and NO.2 repeat.							
1	DISCRIMINATOR	(A) 98.0MHz 1kHz, ±40kHz dev. 70dBf (ANT. input)	Connect a DC voltmeter between CN2 ① and CN2 ② (TUNER UNIT)	MONO 98.0MHz	L4 (TUNER UNIT)	0V	(a)
2	DISTORTION (MONO)	(A) 98.0MHz 1kHz, ±40kHz dev. MONO 70dBf (ANT. input)	(B)	MONO 98.0MHz	L5 (TUNER UNIT)	Minimum distortion	(a)
3	DISTORTION (STEREO)	(C) 98.0MHz 1kHz, ±40kHz dev. Selector : L or R Pilot : ±6kHz dev. 70dBf (ANT. input)	(B)	AUTO 98.0MHz	IFT (TUNER UNIT : A1)	Minimum distortion (L or R)	(a)
4	TUNING LEVEL	(A) 98.0MHz MONO 1kHz, ±40kHz dev. 25dBf (ANT. input)	(B)	MONO 98.0MHz	VR1 (TUNER UNIT)	Adjust VR1 and stop at the point where ED51 (TUNED) goes on.	(a)

SYSTEM CONNECTIONS

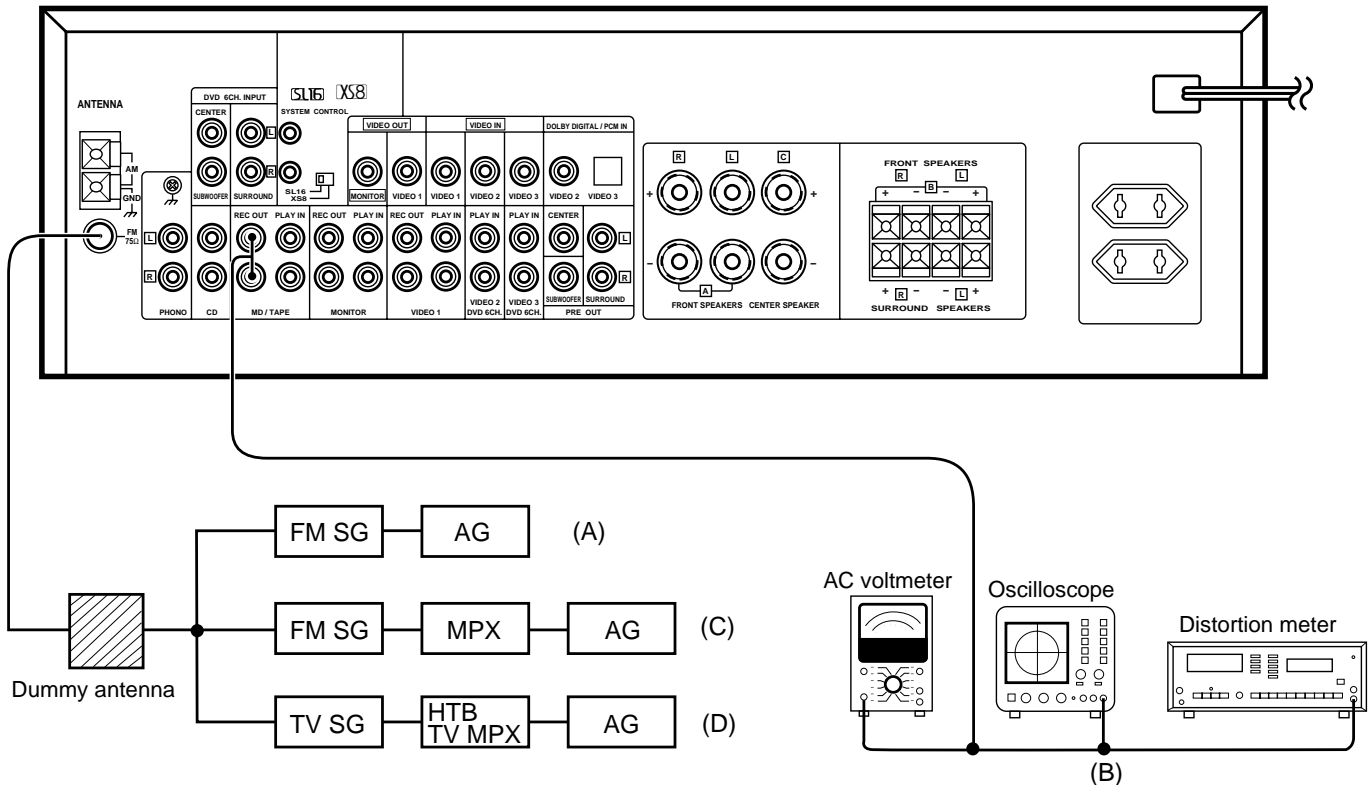

KRF-V8010D/V8010DW

PARTS DESCRIPTIONS

CAPACITORS

CC 45 TH 1H 220 J
 1 2 3 4 5 6

- 1 = Type ... ceramic, electrolytic, etc.
- 2 = Shape ... round, square, ect.
- 3 = Temp. coefficient
- 4 = Voltage rating
- 5 = Value
- 6 = Tolerance

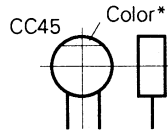

• Capacitor value

- 010 = 1pF
- 100 = 10pF
- 101 = 100pF
- 102 = 1000pF = 0.001μF
- 103 = 0.01μF

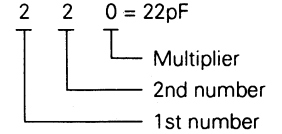

• Temperature coefficient

1st Word	C	L	P	R	S	T	U
Color*	Black	Red	Orange	Yellow	Green	Blue	Violet
ppm/°C	0	-80	-150	-220	-330	-470	-750

2nd Word	G	H	J	K	L
ppm/°C	±30	±60	±120	±250	±500

Example : CC45TH = -470 ± 60ppm/°C

• Tolerance (More than 10pF)

Code	C	D	G	J	K	M	X	Z	P	No code
(%)	±0.25	±0.5	±2	±5	±10	±20	+40 -20	+80 -20	+100 -0	More than 10μF -10 ~ +50 Less than 4.7μF -10 ~ +75

(Less than 10pF)

Code	B	C	D	F	G
(pF)	±0.1	±0.25	±0.5	±1	±2

• Voltage rating

2nd word \ 1st word	A	B	C	D	E	F	G	H	J	K	V
0	1.0	1.25	1.6	2.0	2.5	3.15	4.0	5.0	6.3	8.0	-
1	10	12.5	16	20	25	31.5	40	50	63	80	35
2	100	125	160	200	250	315	400	500	630	800	-
3	1000	1250	1600	2000	2500	3150	4000	5000	6300	8000	-

• Chip capacitors

(EX) C C 7 3 F S L 1 H 0 0 0 J
 1 2 3 4 5 6 7

(Chip) (CH, RH, UJ, SL)

(EX) C K 7 3 F F 1 H 0 0 0 Z
 1 2 3 4 5 6 7

(Chip) (B, F)

Refer to the table above.

- 1 = Type
- 2 = Shape
- 3 = Dimension
- 4 = Temp. coefficient
- 5 = Voltage rating
- 6 = Value
- 7 = Tolerance

Dimension (Chip capacitors)

Dimension code	L	W	T
Empty	5.6 ± 0.5	5.0 ± 0.5	Less than 2.0
A	4.5 ± 0.5	3.2 ± 0.4	Less than 2.0
B	4.5 ± 0.5	2.0 ± 0.3	Less than 2.0
C	4.5 ± 0.5	1.25 ± 0.2	Less than 1.25
D	3.2 ± 0.4	2.5 ± 0.3	Less than 1.5
E	3.2 ± 0.2	1.6 ± 0.2	Less than 1.25
F	2.0 ± 0.3	1.25 ± 0.2	Less than 1.25
G	1.6 ± 0.2	0.8 ± 0.2	Less than 1.0

RESISTORS

• Chip resistor (Carbon)

(EX) R K 7 3 E B 2 B 0 0 0 J
 1 2 3 4 5 6 7

(Chip) (B,F)

• Carbon resistor (Normal type)

(EX) R D 1 4 B B 2 C 0 0 0 J
 1 2 3 4 5 6 7

- 1 = Type
- 2 = Shape
- 3 = Dimension
- 4 = Temp. coefficient
- 5 = Rating wattage
- 6 = Value
- 7 = Tolerance

Dimension

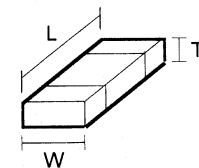

Dimension (Chip resistor)

Dimension code	L	W	T
E	3.2 ± 0.2	1.6 ± 0.2	1.0
F	2.0 ± 0.3	1.25 ± 0.2	1.0
G	1.6 ± 0.2	0.8 ± 0.2	0.5 ± 0.1

Rating wattage

Code	Wattage	Code	Wattage	Code	Wattage
1J	1/16W	2C	1/6W	3A	1W
2A	1/10W	2E	1/4W	3D	2W
2B	1/8W	2H	1/2W		

PC BOARD(Component side view)

POWER SUPPLY UNIT

AC OUTLET

X00-2912-71
A/6

CAUTION REPLACE WITH SAME TYPE AND RATING FUSE(S).

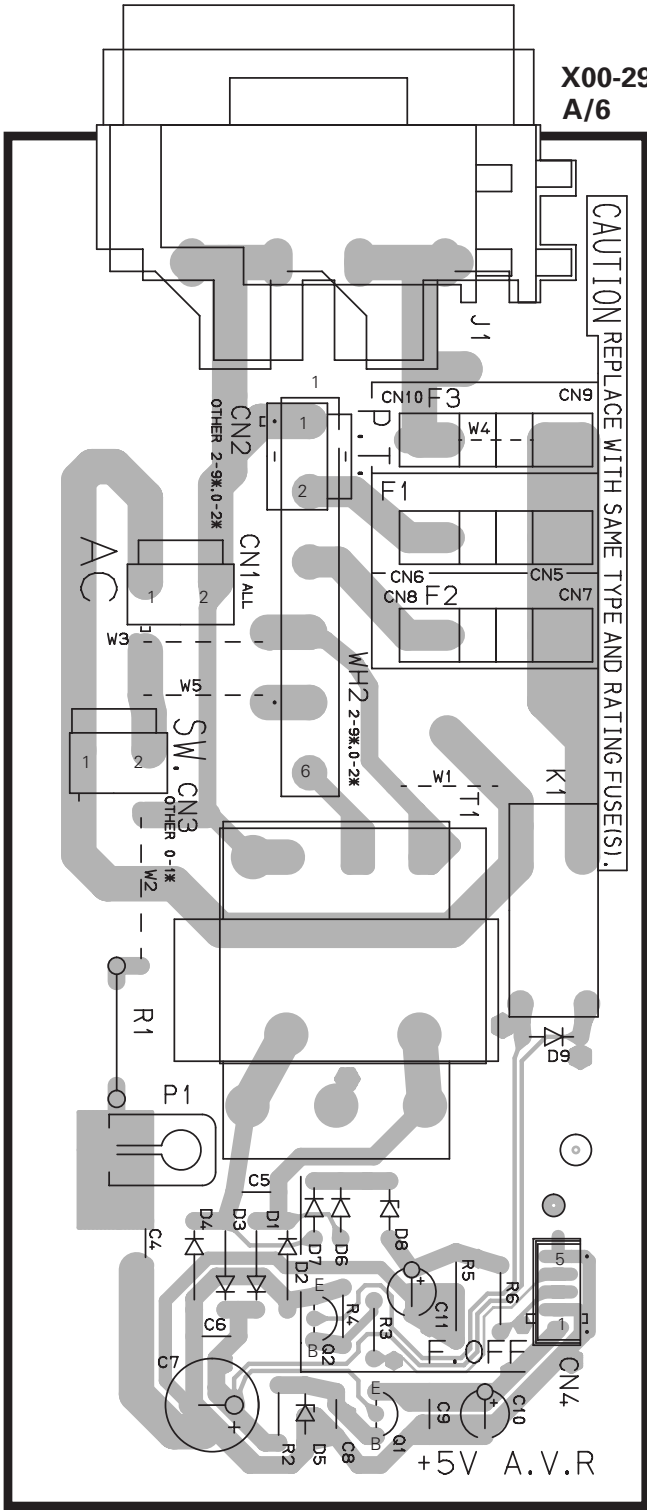

X00 B/6

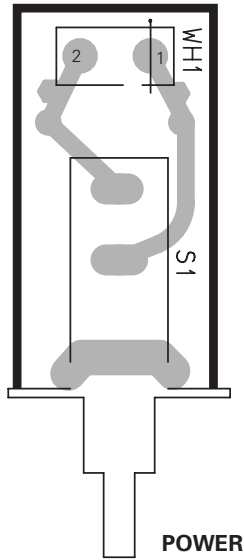

POWER

X00 D/6

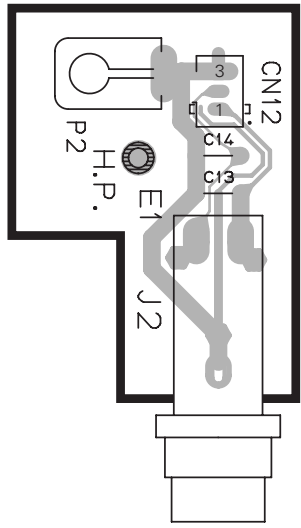

PHONES

PC BOARD(Component side view)

TUNER UNIT
X05-4932-70

ANTENNA

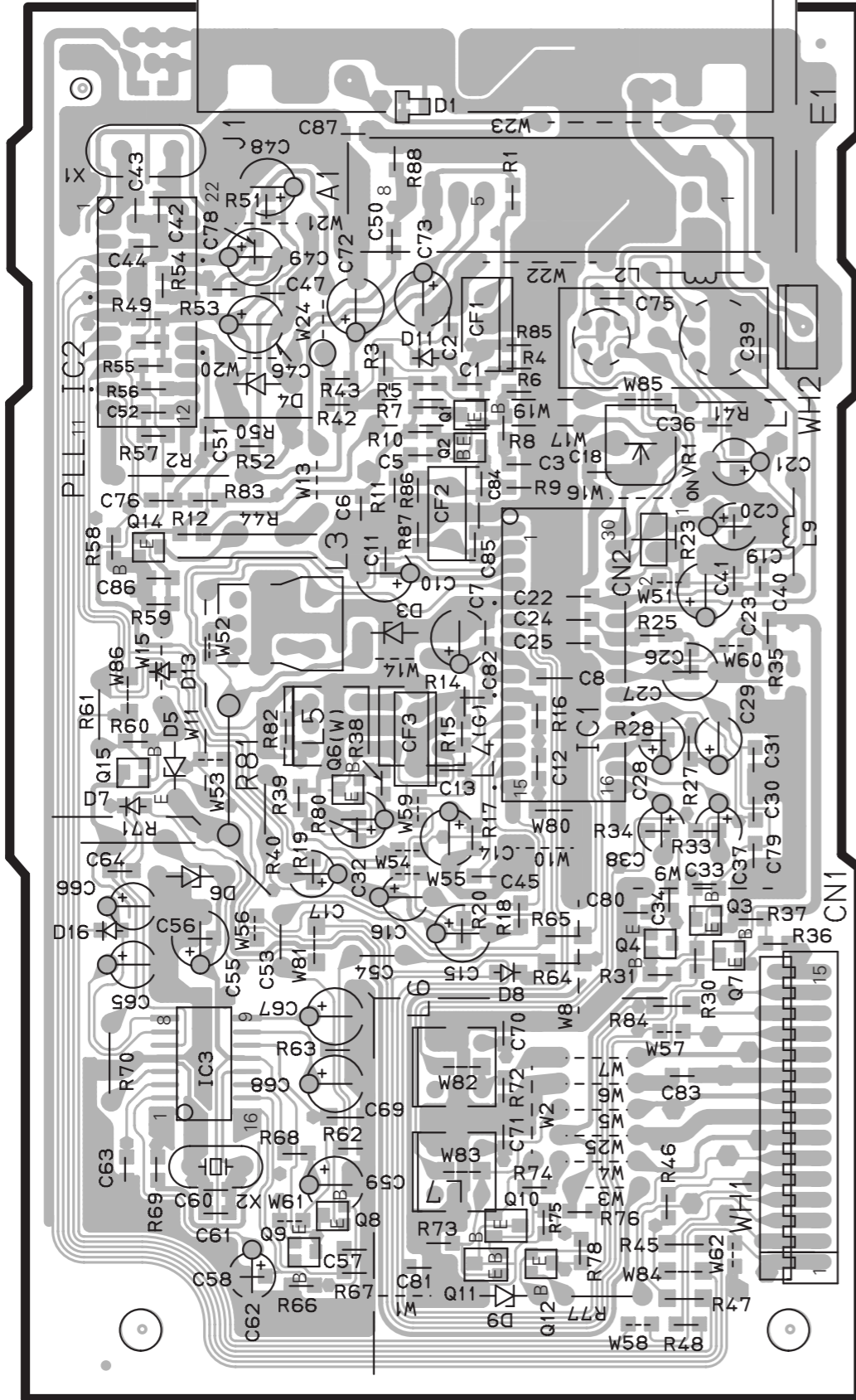

SURROUND UNIT
X08-2952-70

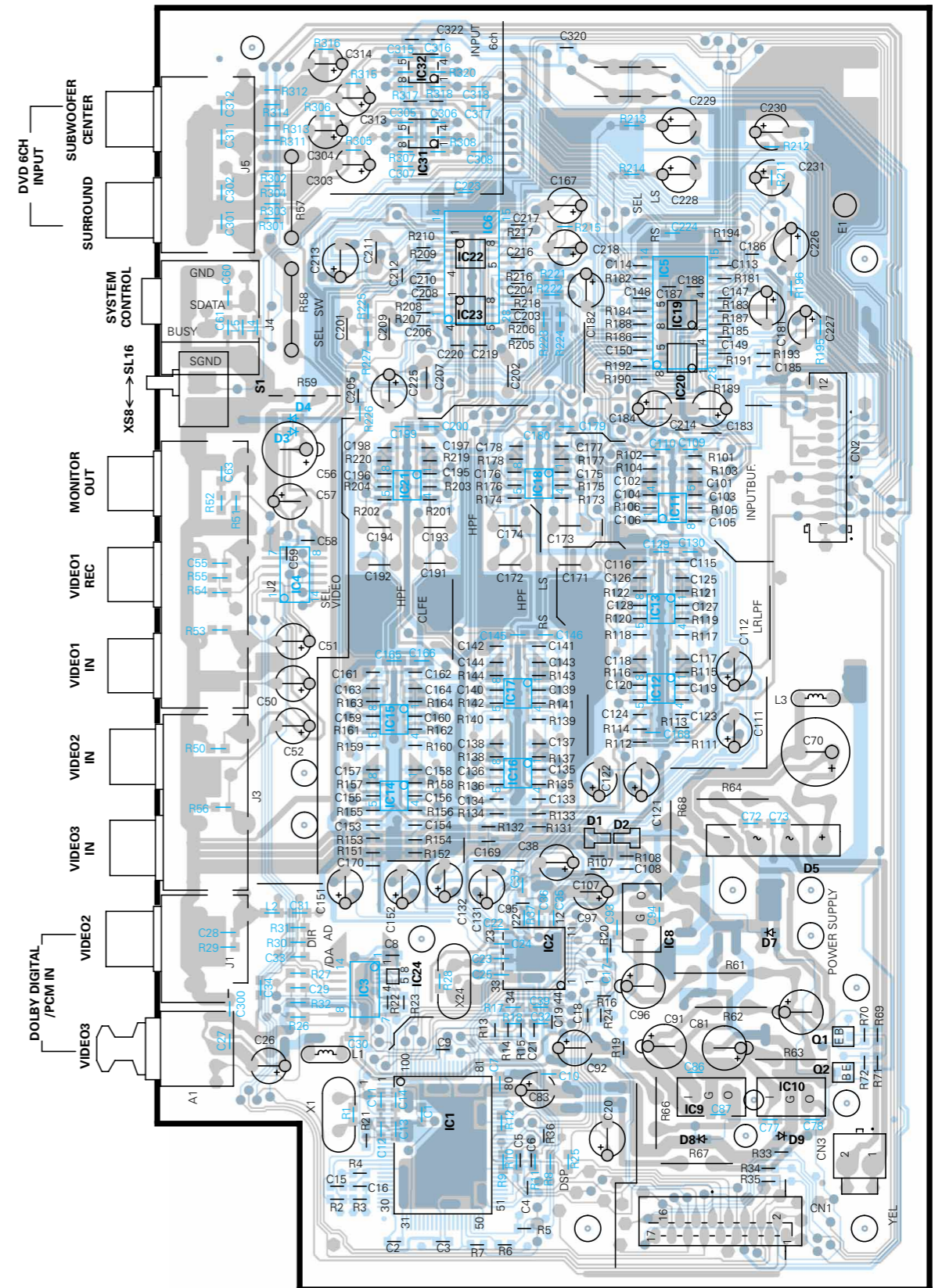

PC BOARD(Component side view)

AUDIO UNIT

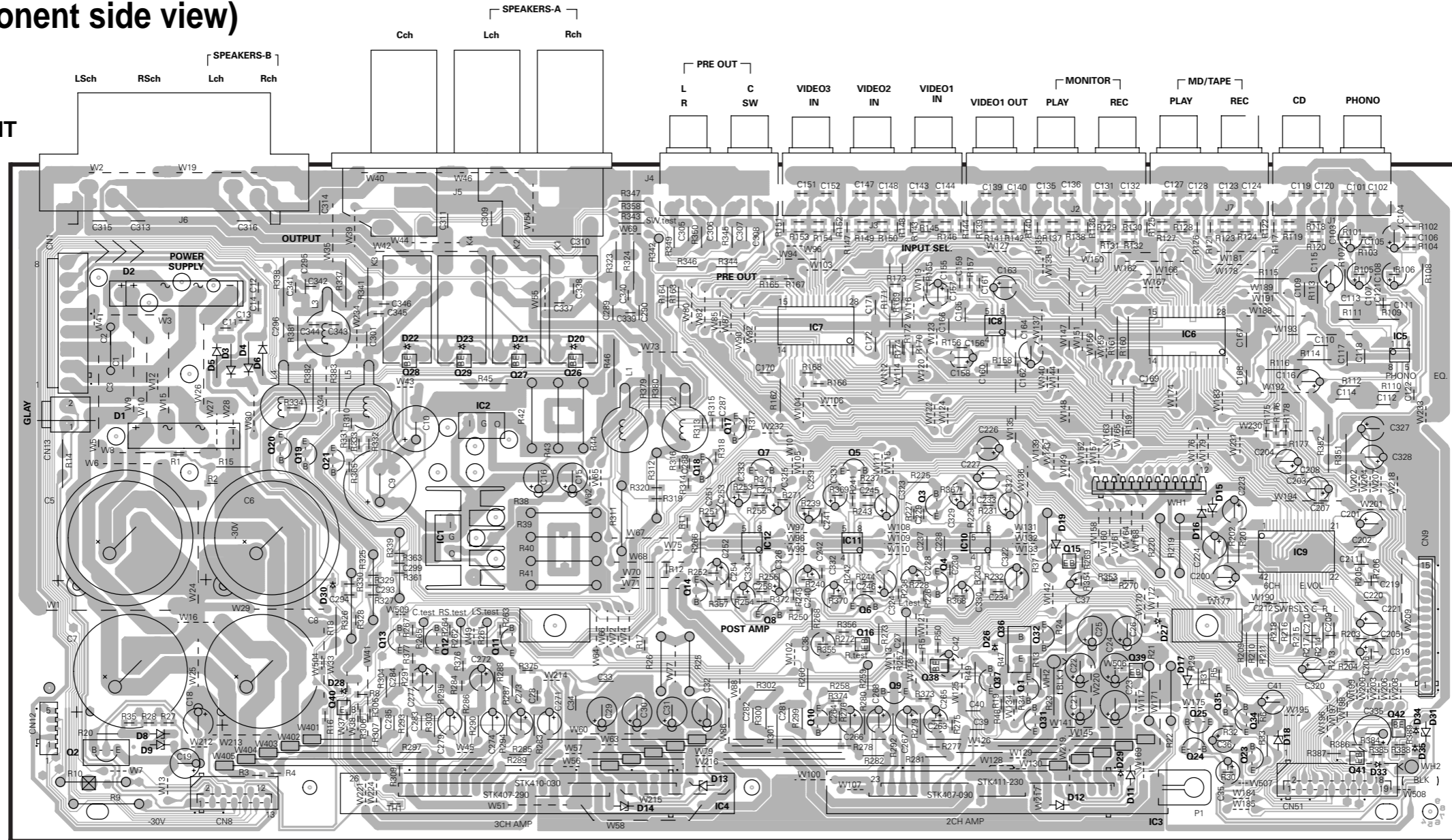

X09 C/3

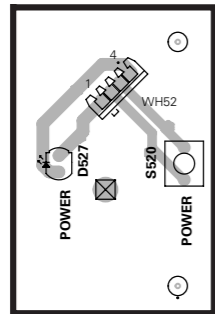

X09-6092-71 A/3

X09 B/3

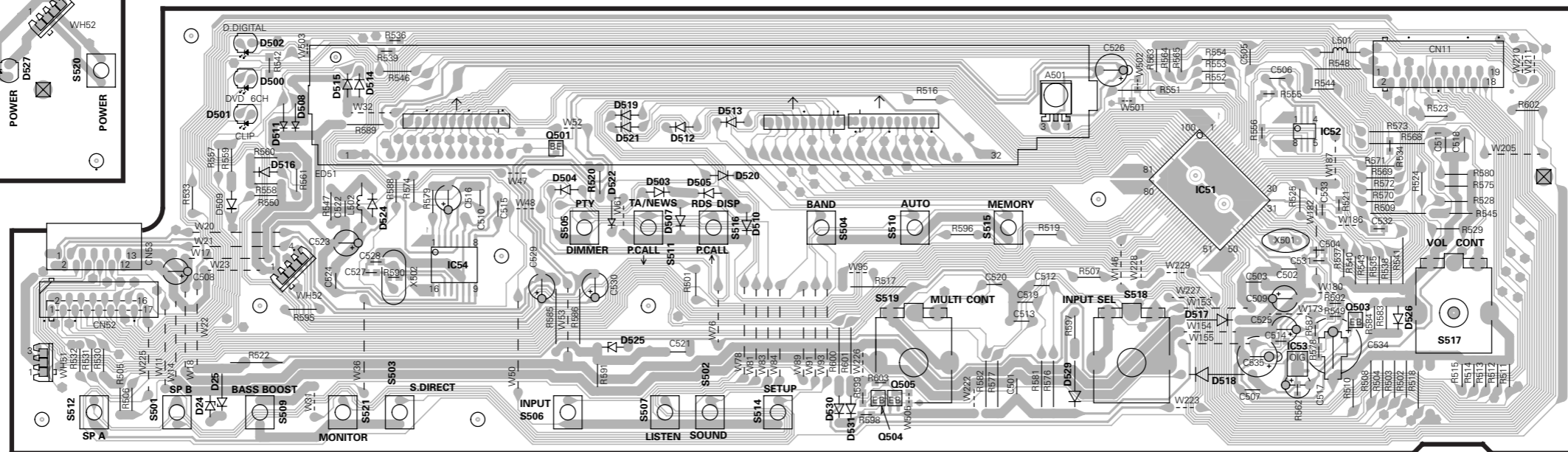

TUNER UNIT
 (X05-482X-XX) 2-70: KRF-V8010D(E,T,X) 3-81: KRF-V8010DW(Q)

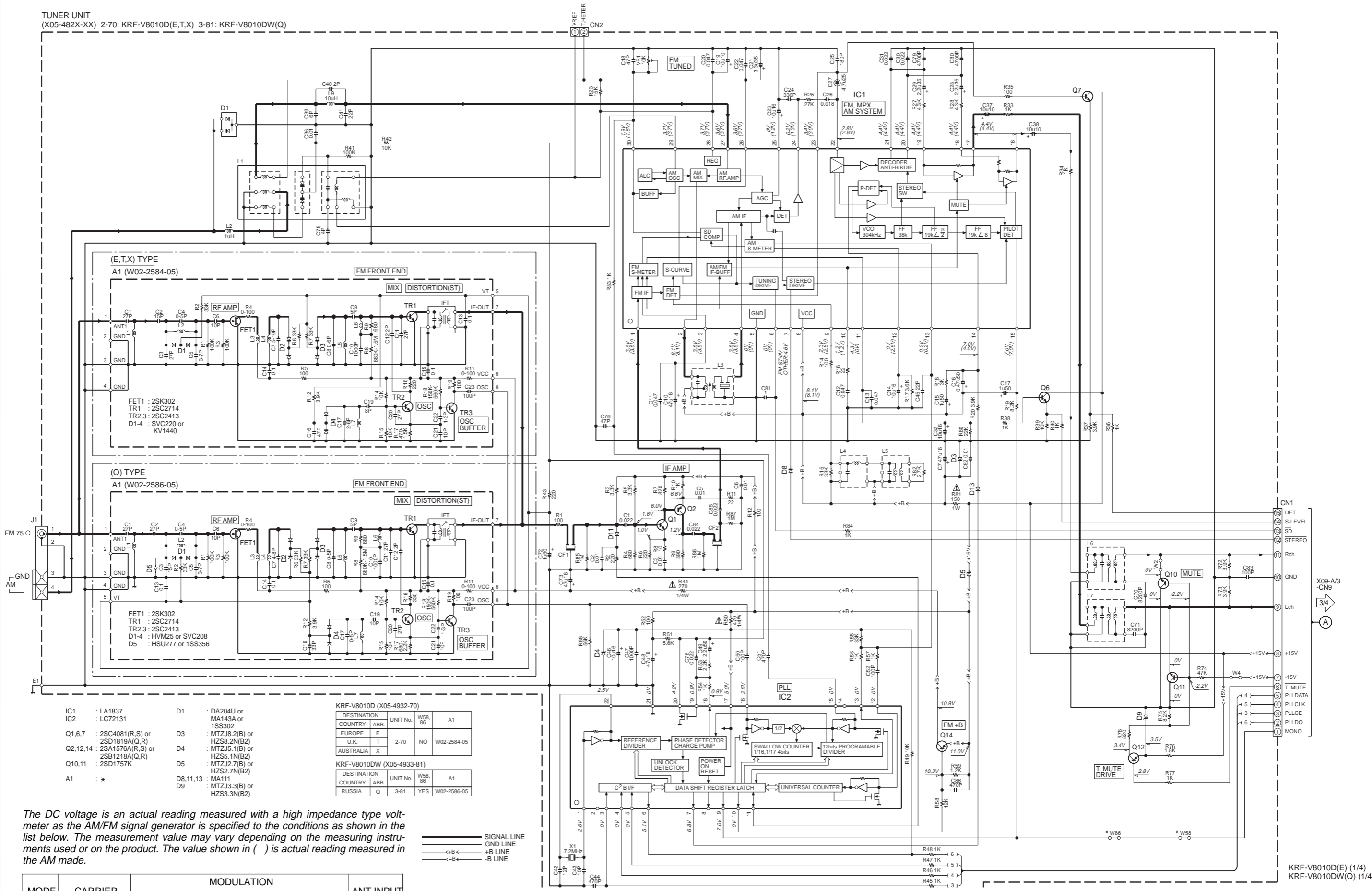

IC1 : LA1837	D1 : DA204U or MA143A or 1SS302	KRF-V8010D (X05-4932-70)
IC2 : LC72131	D3 : MTZJ8.2(B) or HZS8.2N(B2)	DESTINATION COUNTRY ABB. UNIT No. W58, 86 A1
Q1,6,7 : 2SC4081(R,S) or 2SD1819A(Q,R)	D4 : MTZJ5.1(B) or HZS5.1N(B2)	EUROPE E 2-70 NO W02-2584-05
Q2,12,14 : 2SA1578A(R,S) or 2SB1218A(Q,R)	D5 : MTZJ2.7(B) or HZS2.7N(B2)	U.K. T
Q10,11 : 2SD1757K	D8,11,13 : MA111	AUSTRALIA X
A1 : *	D9 : MTZJ3.3(B) or HZS3.3N(B2)	RUSSIA Q 3-81 YES W02-2586-05

The DC voltage is an actual reading measured with a high impedance type voltmeter as the AM/FM signal generator is specified to the conditions as shown in the list below. The measurement value may vary depending on the measuring instruments used or on the product. The value shown in () is actual reading measured in the AM mode.

MODE	CARRIER	MODULATION		ANT INPUT
		FREQUENCY	DEVIATION	
FM	98MHz	1kHz	STEREO 67.5kHz 7.5kHz(Pilot)	60dB
AM	1000(999)kHz	400Hz	MONO 30% MOD	60dB

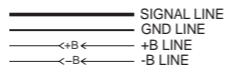

CAUTION: For continued safety, replace safety critical components only with manufacturer's recommended parts (refer to parts list). Δ indicates safety critical components. For continued protection against risk of fire, replace only with same type and rating fuse(s). To reduce the risk of electric shock, leakage-current or resistance measurements shall be carried out (exposed parts are acceptably insulated from the supply circuit) before the appliance is returned to the customer.

Y05-3822-70

KRF-V8010D(V8010DW

KENWOOD

SURROUND UNIT
(X08-2952-70)

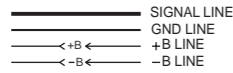

- IC1 : YSS248
- IC2 : CS4226KQG
- IC3 : TC74HCU04AF
- IC4 : NJM2279M
- IC5 : TC9162AF
- IC6 : TC9164AF
- IC8-10 : TA7805SB
- IC11-23,31,32 : NJM4565M
- IC24 : TC7W241FU
- Q1 : 2SC4081(R,S) or 2SC4116(Y,GR)
- Q2 : 2SA1576A(R,S) or 2SA1586(Y,GR)
- D1,2 : DA204U or 1SS302
- D3,4 : UDZ5.1B
- D5 : DZSBA20F03
- D7-9 : UDZ6.2B

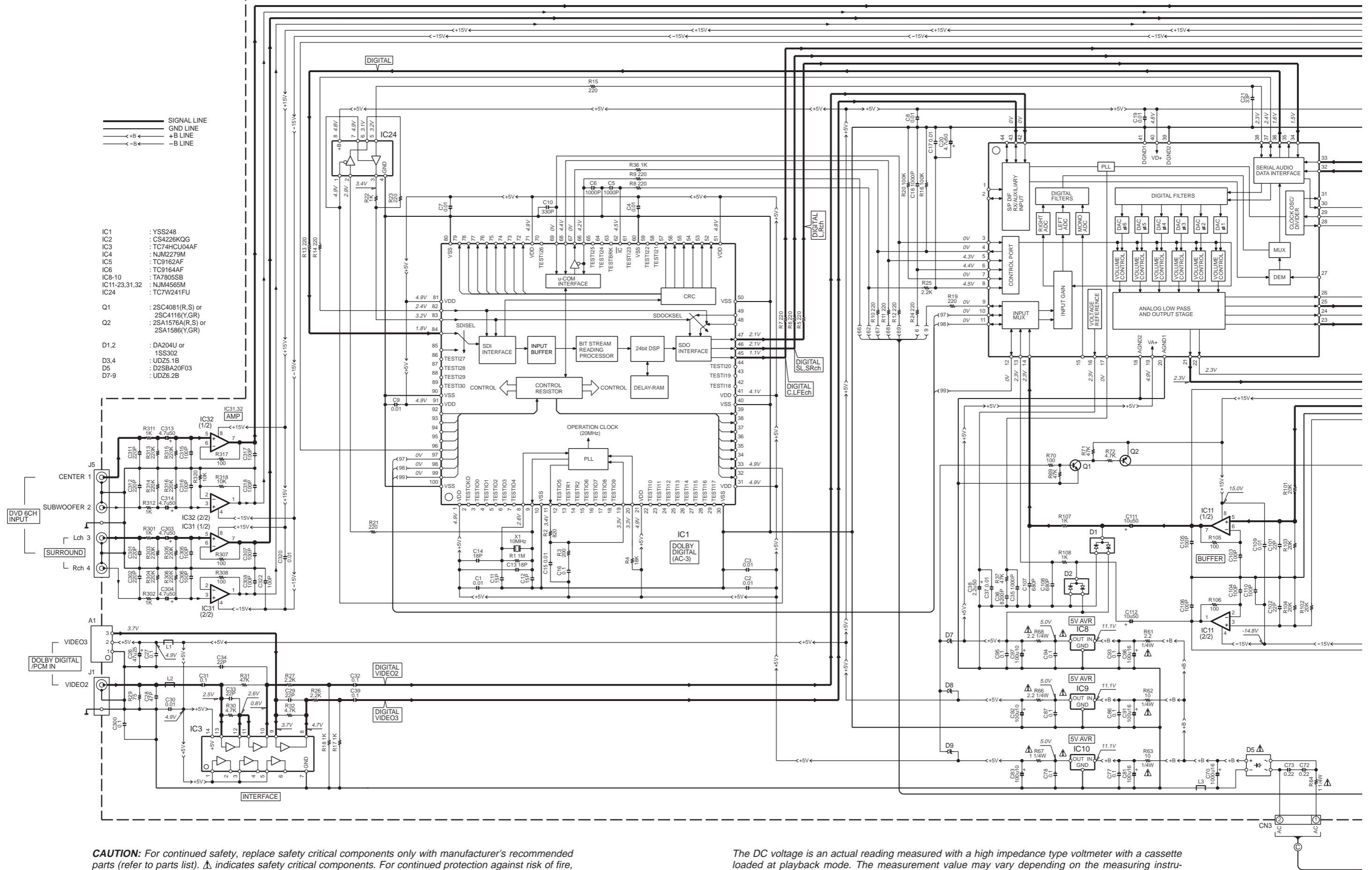

CAUTION: For continued safety, replace safety critical components only with manufacturer's recommended parts (refer to parts list). Δ indicates safety critical components. For continued protection against risk of fire, replace only with same type and rating fuse(s). To reduce the risk of electric shock, leakage-current or resistance measurements shall be carried out (exposed parts are acceptably insulated from the supply circuit) before the appliance is returned to the customer.

The DC voltage is an actual reading measured with a high impedance type voltmeter with a cassette loaded at playback mode. The measurement value may vary depending on the measuring instruments used or on the product. Bias circuit DC voltage is measured while in the record mode.

DOLBY and the double-D symbol are trademarks of Dolby Laboratories Licensing Corporation. Noise reduction circuit made under license from Dolby Laboratories Licensing Corporation.

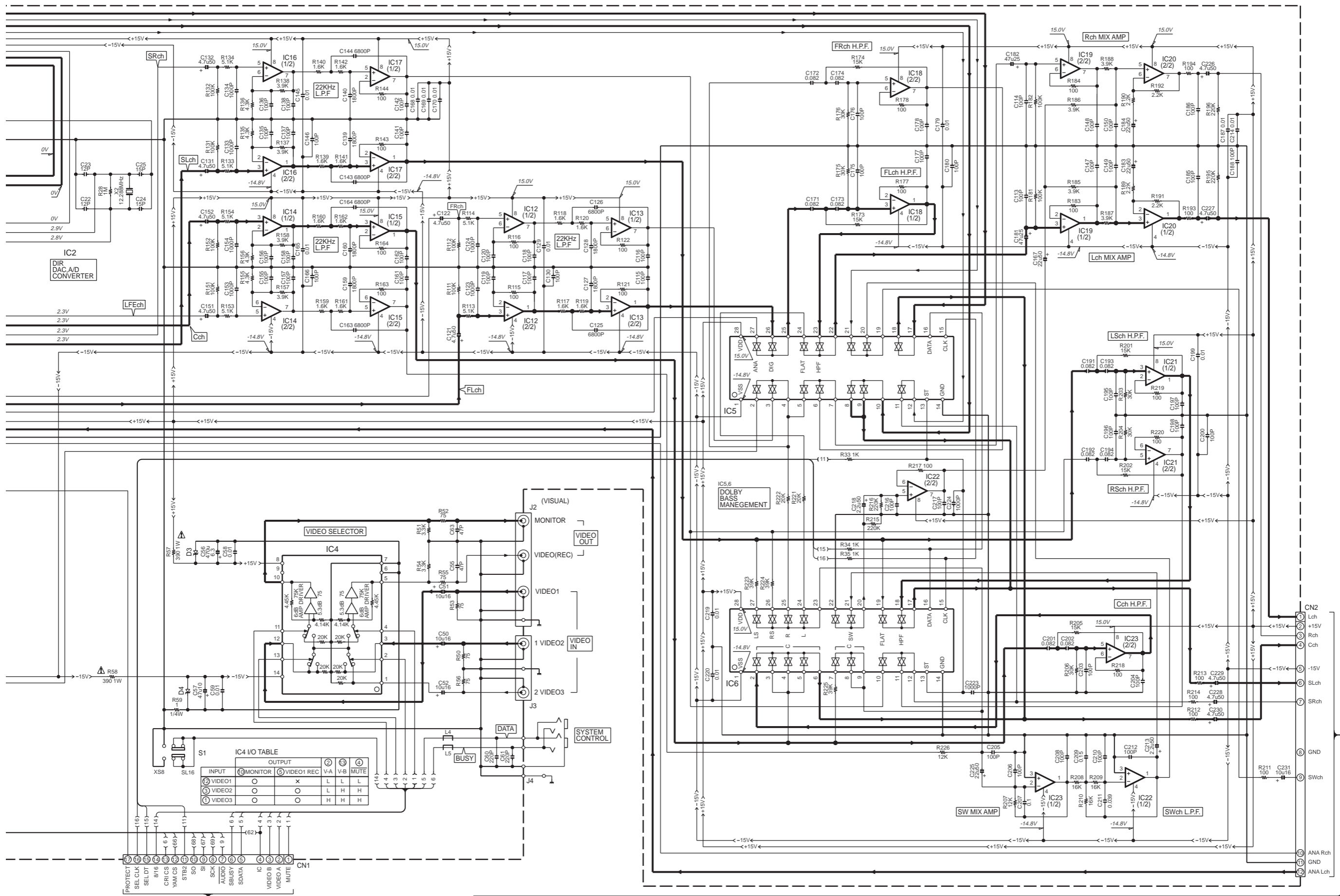

IC4 I/O TABLE

INPUT	MONITOR	VIDEO1 REC	V-A	V-B	MUTE
VIDEO1		X	L	L	L
VIDEO2			L	H	H
VIDEO3			H	H	H

KRF-V8010D (2/4)
KRF-V8010DW (2/4)

KRF-V8010D/V8010DW

Y05-3822-70

KENWOOD

- X09-A/3 -WH1 (3/4)
- X00-TRNS (3/4)
- X09-B/3 -CN52 (4/4)
- ANA Rch (1/2)
- GND (1/2)
- ANA Lch (1/2)

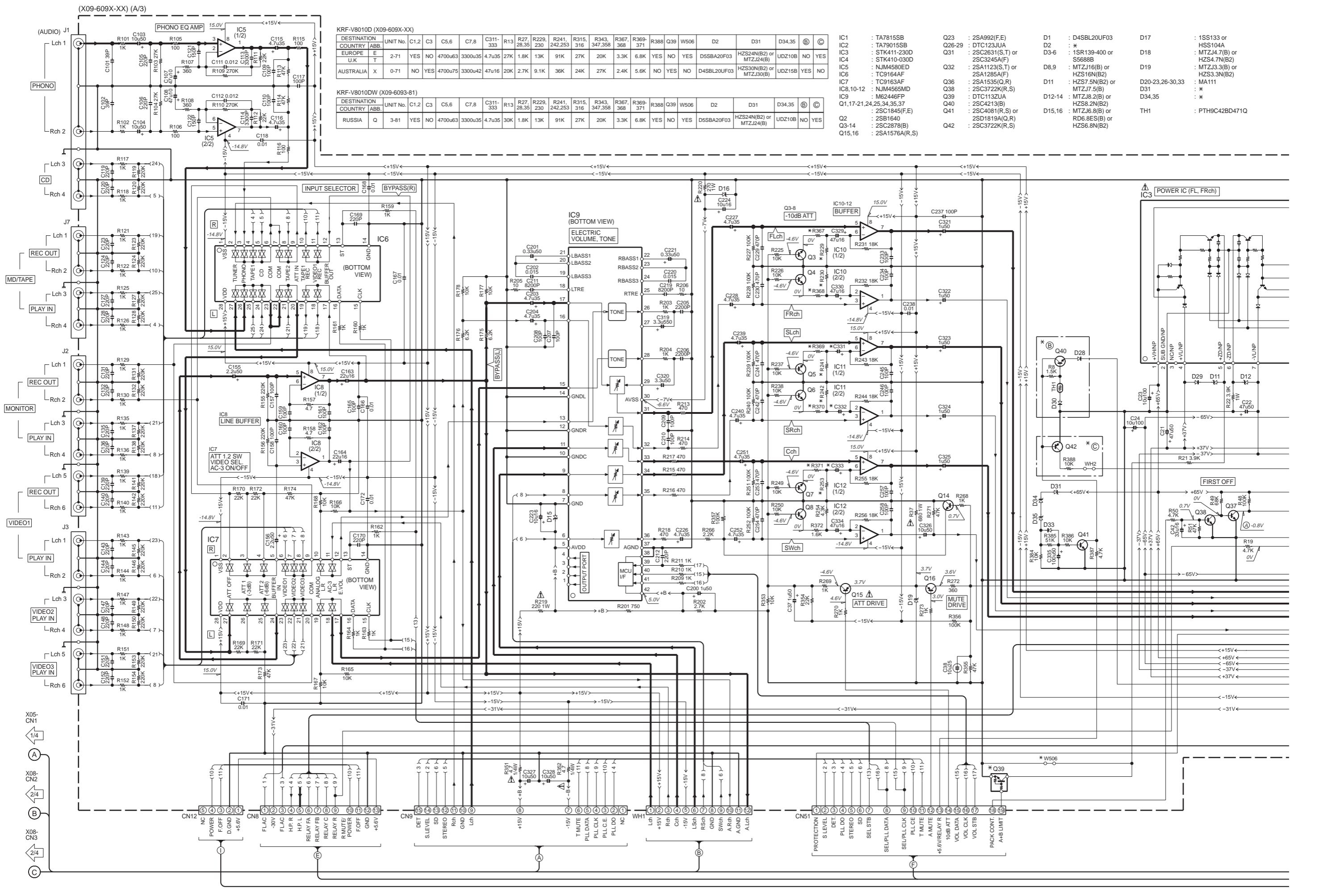

KRF-V8010D (X09-609X-XX)

DESTINATION COUNTRY ABB.	UNIT No.	C1,2	C3	C5,6	C7,8	C311-333	R13	R27,28,35	R229,230	R241,242,253	R315,316	R343,347,358	R367,368	R369,371	R388	Q39	W506	D2	D31	D34,35	Ⓟ	Ⓢ	
EUROPE	E	2-71	YES	NO	4700u63	3300u35	4.7u35	27K	1.8K	13K	91K	27K	20K	3.3K	6.8K	YES	NO	YES	D5SBA20F03	HZS24N(B2) or MTZJ24(B)	UDZ10B	NO	YES
U.K.	T																						
AUSTRALIA	X	0-71	NO	YES	4700u75	3300u42	47u16	20K	2.7K	9.1K	36K	24K	27K	2.4K	5.6K	NO	YES	NO	D4SBL20UF03	HZS30N(B2) or MTZJ30(B)	UDZ15B	YES	NO

KRF-V8010DW (X09-6093-81)

DESTINATION COUNTRY ABB.	UNIT No.	C1,2	C3	C5,6	C7,8	C311-333	R13	R27,28,35	R229,230	R241,242,253	R315,316	R343,347,358	R367,368	R369,371	R388	Q39	W506	D2	D31	D34,35	Ⓟ	Ⓢ	
RUSSIA	Q	3-81	YES	NO	4700u63	3300u35	4.7u35	30K	1.8K	13K	91K	27K	20K	3.3K	6.8K	YES	NO	YES	D5SBA20F03	HZS24N(B2) or MTZJ24(B)	UDZ10B	NO	YES

IC1 : TA7815SB	Q23 : 2SA992(F,E)	D1 : D4SBL20UF03	D17 : 1SS133 or HSS104A
IC2 : TA79015SB	Q26-29 : DTC123JUA	D2 : *	D18 : MTZJ4.7(B) or HZS4.7N(B2)
IC3 : STK411-230D	Q31 : 2SC2631(S,T) or 2SC3245(F)	D3-6 : 1SR139-400 or S5688B	D19 : *
IC4 : STK410-030D	Q32 : 2SA1123(S,T) or 2SA1285(F)	D8,9 : MTZJ16(B) or HZS16N(B2)	D20-23,26-30,33 : MA111
IC5 : NJM4580ED	Q36 : 2SA1535(Q,R)	D11 : HZS7.5N(B2) or HZS7.5(B)	D31 : *
IC6 : TC9164AF	Q38 : 2SC3722K(R,S)	D12-14 : MTZJ8.2(B) or HZS8.2N(B2)	D34,35 : *
IC7 : TC9163AF	Q40 : 2SC4213(B)	D15,16 : MTZJ6.8(B) or RD6.8S(B) or HZS6.8N(B2)	TH1 : PTH9C42BD471Q
IC8,10-12 : NJM4565MD	Q41 : 2SC4081(R,S) or 2SD1819A(Q,R)		
IC9 : M62446FP	Q42 : 2SC3722K(R,S)		
Q1,17-21,24,25,34,35,37 : 2SC1845(F,E)			
Q2 : 2SB1640			
Q3-14 : 2SC2878(B)			
Q15,16 : 2SA1576A(R,S)			

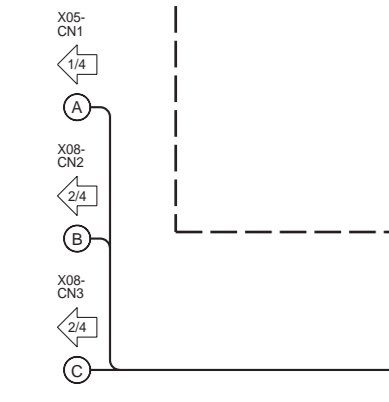

DC VOLTAGE FOR IC3 (STK411-230D)

PIN No.	1	2	3	4	5	6	7	8	9-11	12-15	16	17	18,19	20	21-23
E,T	54.9V	22.0V	22.5V	14.5V	-14.2V	-22.2V	-54.9V	-21.7V			-52.7V	53.2V		-51.5V	0V
Q	54.0V	0V	23.2V	23.7V	15.8V	-15.7V	-23.7V	-53.9V			-23.2V	0V		-50.2V	0V
X	64.0V	64.0V	35.5V	27.3V	-27.4V	-35.4V	-63.9V	-34.8V			-61.6V	62.1V		-60.4V	

DC VOLTAGE FOR IC4 (STK410-030D)

PIN No.	1	2	3	4	5	6	7	8	9-11	12-15	16	17	18,19	20	21-24	25	26
E,T	54.9V	21.9V	22.5V	14.4V	-14.5V	-22.5V	-54.9V	-22.0V			-52.6V	53.2V		-51.4V	-22.0V		
Q	54.0V	0V	23.2V	23.7V	15.8V	-15.7V	-23.7V	-53.9V			-23.2V	0V		-50.2V	0V		
X	64.0V	34.9V	35.5V	27.5V	-27.4V	-35.5V	-63.9V	-34.5V			-60.9V	61.4V		-59.7V			

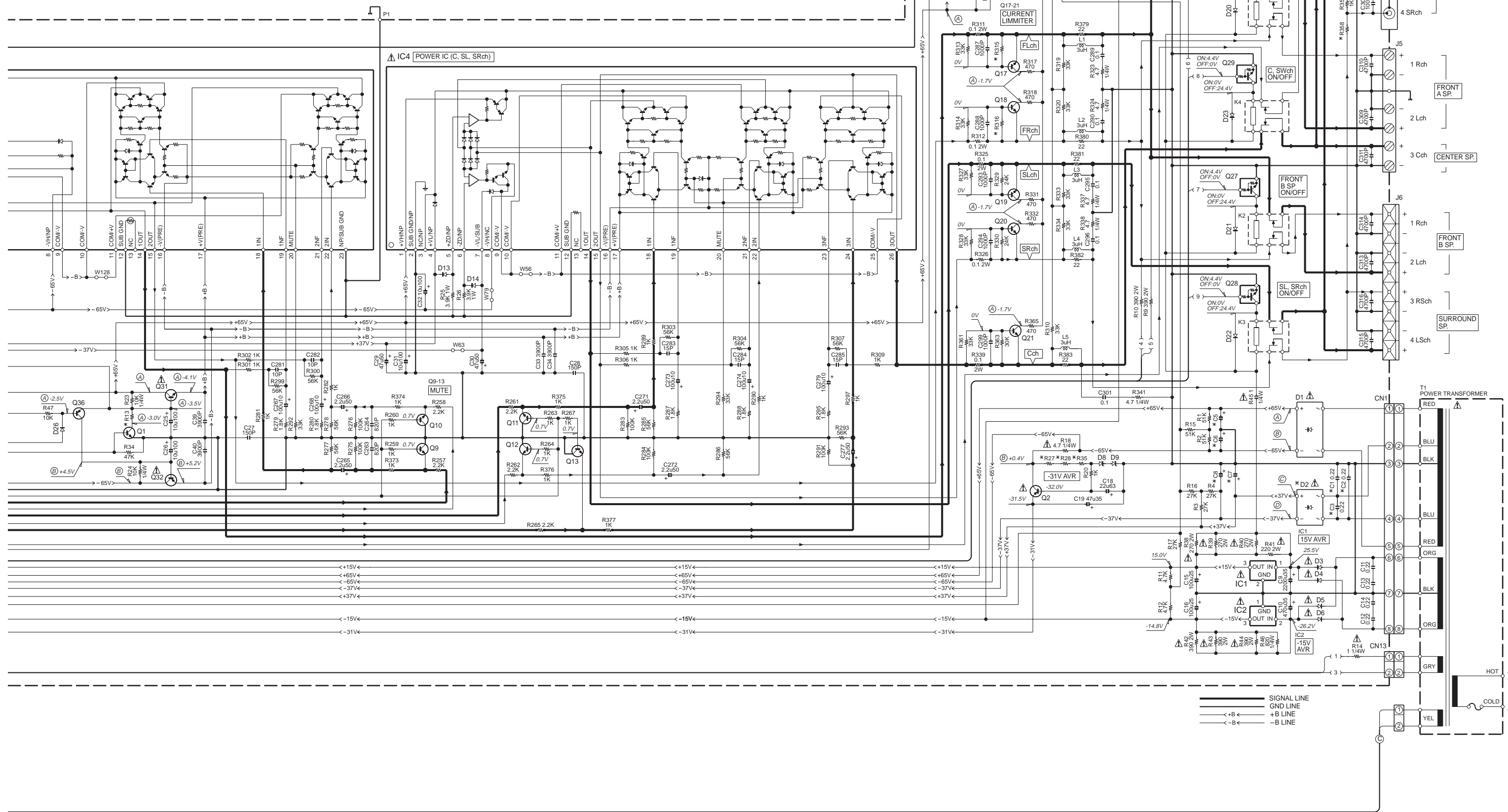

CAUTION: For continued safety, replace safety critical components only with manufacturer's recommended parts (refer to parts list). Δ indicates safety critical components. For continued protection against risk of fire, replace only with same type and rating fuse(s). To reduce the risk of electric shock, leakage-current or resistance measurements shall be carried out (exposed parts are acceptably insulated from the supply circuit) before the appliance is returned to the customer.

The DC voltage is an actual reading measured with a high impedance type voltmeter with a cassette loaded at playback mode. The measurement value may vary depending on the measuring instruments used or on the product. Bias circuit DC voltage is measured while in the record mode.

- 2SA1123
- 2SA992
- 2SC1845
- 2SC2003
- 2SC2631
- 2SC2878
- 2SC3940A
- 2SA1586
- 2SB1218A
- 2SC3722K
- 2SC4081
- 2SC4116
- 2SD1819A
- 2SA1535

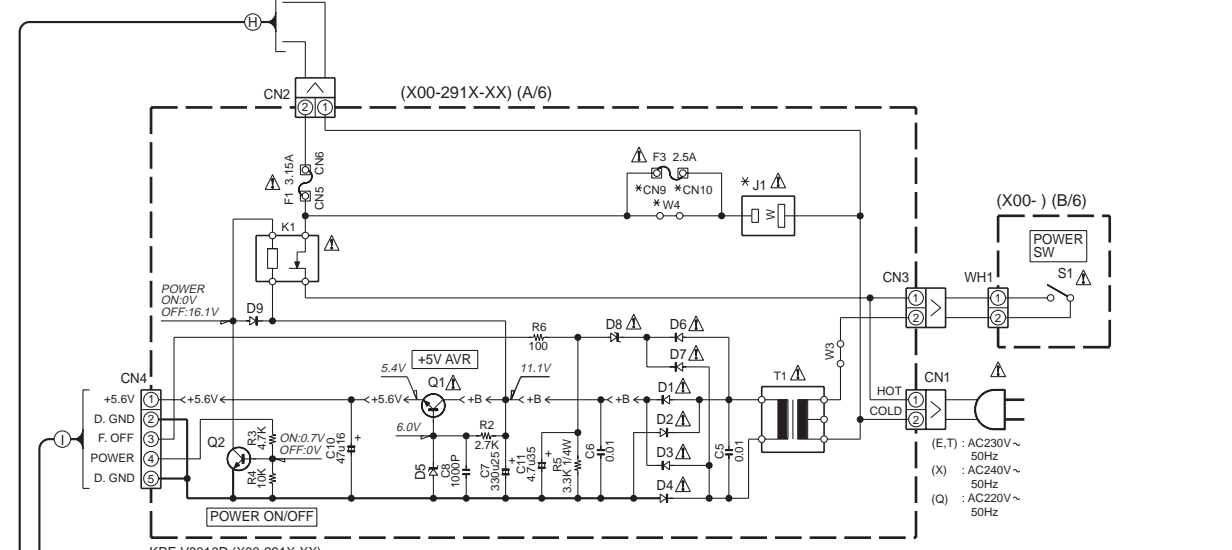

KRF-V8010D (X00-291X-XX)		UNIT No.	CN9,10	W4	J1
COUNTRY	ABB.	2-71	YES	NO	E03-0149-05
EUROPE	E	0-51	NO	YES	E03-0310-05
U.K.	T	0-71	NO	YES	E03-0325-05
AUSTRALIA	X	0-71	NO	YES	E03-0325-05

KRF-V8010DW (X00-2912-71)		UNIT No.	CN9,10	W4	J1
COUNTRY	ABB.	2-71	YES	NO	E03-0149-05
RUSSIA	Q	2-71	YES	NO	E03-0149-05

- DTC123JUA
- TC74HCU04AF
- YSS248
- NJM4565M
- NJM4565MD
- NJM4580ED
- NJM2279M
- LA1837
- TA7805SB
- LC72131
- TC7W241FU
- DA204U
- S-80740AL-A4
- SAA6579T/R
- TC9162AF
- TC9163AF
- TC9164AF
- X24C02S
- M62446FP

KRF-V8010D(E) (3/4)
KRF-V8010D(W) (3/4)

Y05-3822-70

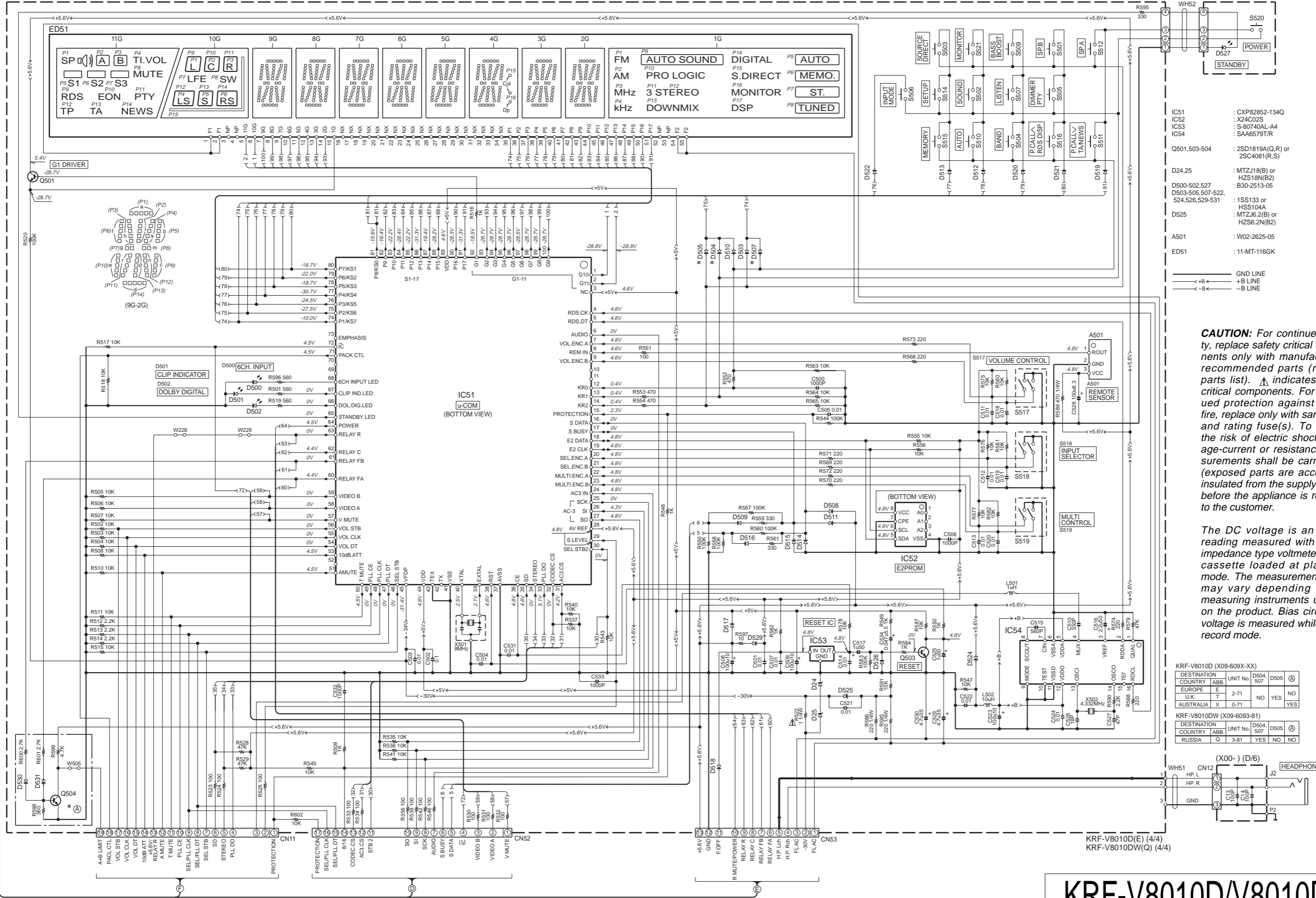

- IC51 : CXP82852-134Q
- IC52 : X24C02S
- IC53 : S-80740AL-A4
- IC54 : SAA6579TR
- Q501,503-504 : 2SD1819A(Q,R) or 2SC4081(R,S)
- D24,25 : MTZ118(B) or HZS118N(B2)
- D500-502,527 : B30-2513-05
- D503-505,507-522, 524,526,529-531 : 1SS133 or HSS104A
- D525 : MTZJ6.2(B) or HZS6.2N(B2)
- A501 : W02-2625-05
- ED51 : 11-MT-116GK

— GND LINE
— +B LINE
— -B LINE

CAUTION: For continued safety, replace safety critical components only with manufacturer's recommended parts (refer to parts list). ⚠ indicates safety critical components. For continued protection against risk of fire, replace only with same type and rating fuse(s). To reduce the risk of electric shock, leakage-current or resistance measurements shall be carried out (exposed parts are acceptably insulated from the supply circuit) before the appliance is returned to the customer.

The DC voltage is an actual reading measured with a high impedance type voltmeter with a cassette loaded at playback mode. The measurement value may vary depending on the measuring instruments used or on the product. Bias circuit DC voltage is measured while in the record mode.

KRF-V8010D (X09-609X-XX)				
DESTINATION	UNIT No.	D504	D505	
EUROPE	E	2-71	NO	YES
U.K.	T		NO	YES
AUSTRALIA	X	0-71		YES

KRF-V8010DW (X09-6093-81)				
DESTINATION	UNIT No.	D504	D505	
RUSSIA	Q	3-81	YES	NO

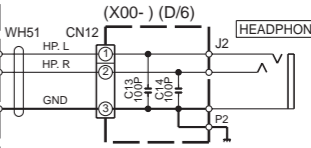

KRF-V8010D/V8010DW

Y05-3822-70

KENWOOD

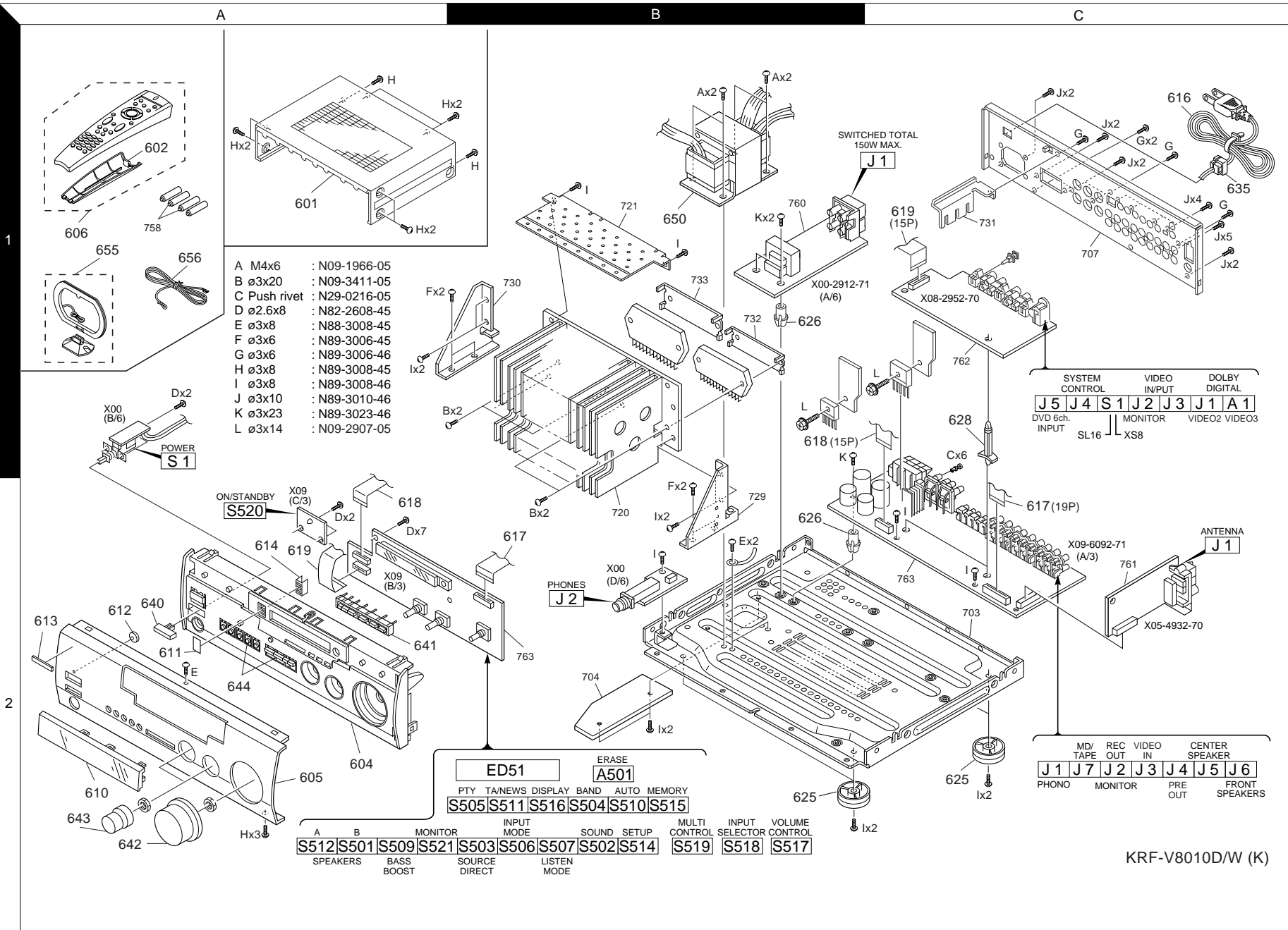

KRF-V8010D/W (K)

Parts with exploded numbers larger than 700 are not supplied.

* New Parts

Parts without **Parts No.** are not supplied.
Les articles non mentionnes dans le **Parts No.** ne sont pas fournis.
Teile ohne **Parts No.** werden nicht geliefert.

①

Ref. No	Add-ress	New Parts	Parts No.	Description	Desti-nation	Re-marks
KRF-V8010D/V8010DW						
601	1A	*	A01-3617-01	METALLIC CABINET	X1	
601	1A	*	A01-3619-01	METALLIC CABINET	ET1Q1	
602	1A	*	A09-0366-08	BATTERY COVER		
604	2A	*	A22-1816-01	SUB PANEL	ET1Q1	
605	2A	*	A60-1545-02	PANEL	ET1Q1	
605	2A	*	A60-1561-01	PANEL	X1	
606	1A	*	A70-1252-05	REMOTE CONTROL ASSY(RC-D0507)		
610	2A	*	B10-3428-12	FRONT GLASS		
611	2A	*	B11-0367-04	SMOKED FILTER		
612	2A	*	B12-0341-04	INDICATOR		
613	2A	*	B43-0302-04	KENWOOD BADGE		
614	2A	*	B11-0375-04	SMOKED FILTER		
-			B46-0096-53	WARRANTY CARD	X1	
-			B46-0310-03	WARRANTY CARD	ET1Q1	
-			B58-0945-03	CAUTION CARD	T1	
-			B58-0965-13	CAUTION CARD (PL)	T1X1	
-			B58-0966-13	CAUTION CARD (PL)	E	
-			B58-1526-03	CAUTION CARD (P4,ORI,A4,1(Q))	Q1	
-			B60-3617-00	INSTRUCTION MANUAL	T1Q1X1	
-			B60-3619-00	INSTRUCTION MANUAL	E	
-		*	B60-3627-00	INSTRUCTION MANUAL	Q1	
-		*	B60-4057-00	INSTRUCTION MANUAL(EN)	T1Q1X1	
-		*	B60-4058-00	INSTRUCTION MANUAL(EN,FR)	E	
-		*	B60-4059-00	INSTRUCTION MANUAL(IT,ES)	E	
-		*	B60-4060-00	INSTRUCTION MANUAL(GE)	E	
Δ 616	1C		E30-2592-15	AC POWER CORD	EQ1	
Δ 616	1C		E30-2717-05	AC POWER CORD	X1	
Δ 616	1C		E30-2721-05	AC POWER CORD	T1	
617	2B, 2C		E35-2016-05	FLAT CABLE 19P		
618	2A, 1B		E35-2017-05	FLAT CABLE 15P		
619	2A, 1C		E35-2018-05	FLAT CABLE 15P		
Δ F1			F05-3121-05	FUSE (SEMKO) (250V T3.15AL)		
Δ F3			F05-2525-05	FUSE (SEMKO) (250V T2.5AL)	EQ1	
-			H10-7492-02	POLYSTYRENE FOAMED FIXTURE		
-			H10-7493-02	POLYSTYRENE FOAMED FIXTURE		
-			H25-0232-04	PROTECTION BAG (235X350X0.03)	EQ1X1	
-			H25-0391-04	PROTECTION BAG		
-			H25-0651-04	PROTECTION BAG	T1	
-		*	H50-3084-04	ITEM CARTON CASE	ET1X1	
-		*	H50-3148-04	ITEM CARTON CASE	Q1	
625	2B, 2C		J02-1168-03	FOOT		
626	1B, 2B		J19-3752-14	UNIT HOLDER		
628	1C		J19-5919-05	UNIT HOLDER		
Δ 635	1C		J42-0083-05	POWER CORD BUSHING		
-			J61-0307-05	WIRE BAND		
640	2A		K27-2275-04	KNOB (BUTTON)		
641	2A		K29-7311-03	KNOB		
642	2A		K29-7312-04	KNOB		
643	2A		K29-7313-04	KNOB		
644	2A	*	K29-7371-02	KNOB	X1	

L: Scandinavia K: USA P: Canada R: Mexico C: China I: Malaysia
Y: PX(Far East, Hawaii) T: Europe E: Europe G: Germany V: China(Shanghai)
Y: AAFES(Europe) X: Australia Q: Russia H: Korea M: Other Areas Δ indicates safety critical components.

* New Parts

Parts without **Parts No.** are not supplied.
Les articles non mentionnes dans le **Parts No.** ne sont pas fournis.
Teile ohne **Parts No.** werden nicht geliefert.

②

Ref. No	Add-ress	New Parts	Parts No.	Description	Desti-nation	Re-marks
Δ 650	1B	*	L07-2584-05	POWER TRANSFORMER	ET1	
Δ 650	1B	*	L07-2585-05	POWER TRANSFORMER	Q1	
Δ 650	1B	*	L07-2586-05	POWER TRANSFORMER	X1	
655	1A		T90-0833-05	LOOP ANTENNA		
656	1A		T90-0836-05	LEAD WIRE ANTENNA		
POWER SUPPLY (X00-2912-71)						
C5, 6			CK45FF1H103Z	CERAMIC 0.010UF Z		
C7			CE04DW1E331M	ELECTRO 330UF 25WV		
C8			CK45FB1H102K	CERAMIC 1000PF K		
C10			CE04KW1C470M	ELECTRO 47UF 16WV		
C11			CE04KW1V4R7M	ELECTRO 4.7UF 35WV		
C13, 14			CC45FSL1H101J	CERAMIC 100PF J		
CN1-3			E40-4245-05	PIN ASSY		
CN4			E40-8197-05	SOCKET FOR PIN ASSY		
CN12			E40-3247-05	PIN ASSY		
Δ J1	1C		E03-0149-05	AC OUTLET	EQ1	
Δ J1	1C		E03-0310-05	AC OUTLET	T1	
Δ J1	1C		E03-0325-05	AC OUTLET	X1	
J2	2B		E11-0127-05	PHONE JACK (3P)		
CN5, 6			J13-0075-05	FUSE CLIP		
CN9, 10			J13-0075-05	FUSE CLIP	EQ1	
E1			J11-0808-05	WIRE CLAMPER		
Δ T1			L07-2569-05	POWER TRANSFORMER		
Δ K1			S76-0070-05	MAGNETIC RELAY		
Δ S1	1A		S68-0100-05	PUSH SWITCH,POWER		
Δ D1-4			S5688B	DIODE		
Δ D1-4			1SR139-400	DIODE		
Δ D5			HZS6.2N(B2)	ZENER DIODE		
Δ D5			MTZJ6.2(B)	ZENER DIODE		
Δ D6, 7			HSS104A	DIODE		
Δ D6, 7			1SS133	DIODE		
Δ D8			HZS2.7N(B2)	ZENER DIODE		
Δ D8			MTZJ2.7(B)	ZENER DIODE		
Δ D9			HSS104A	DIODE		
Δ D9			1SS133	DIODE		
Δ Q1			2SC3940A(R,S)	TRANSISTOR		
Δ Q2			2SC2003(L,K)	TRANSISTOR		
TUNER (X05-4932-70)						
C1			CK73FB1H223K	CHIP C 0.022UF K		
C2, 3			CK73FB1H103K	CHIP C 0.010UF K		
C5, 6			CK73FB1H103K	CHIP C 0.010UF K		
C7			CE04LW1C470M	ELECTRO 47UF 16WV		
C10			CE04LW1C470M	ELECTRO 47UF 16WV		
C11-13			CK73FB1H473K	CHIP C 0.047UF K		
C14			CE04LW1C100M	ELECTRO 10UF 16WV		
C15			CE04LW1H010M	ELECTRO 1.0UF 50WV		
C16			C90-3251-05	ELECTRO 0.47UF 50WV		
C17			C90-3253-05	ELECTRO 1.0UF 50WV		
C18			CC73FCH1H470J	CHIP C 47PF J		
C19			C90-3217-05	ELECTRO 10UF 10WV		
C20			CK73FB1H473K	CHIP C 0.047UF K		

L: Scandinavia K: USA P: Canada R: Mexico C: China I: Malaysia
Y: PX(Far East, Hawaii) T: Europe E: Europe G: Germany V: China(Shanghai)
Y: AAFES(Europe) X: Australia Q: Russia H: Korea M: Other Areas Δ indicates safety critical components.

PARTS LIST

KRF-V8010D/V8010DW

* New Parts

Parts without **Parts No.** are not supplied.
Les articles non mentionnes dans le **Parts No.** ne sont pas fournis.
Teile ohne **Parts No.** werden nicht geliefert.

3

Ref. No	Add-ress	New Parts	Parts No.	Description	Desti-nation	Re-marks
C21			C90-3241-05	ELECTRO 3.3UF 35WV		
C22			CK73FB1H473K	CHIP C 0.047UF K		
C23			CE04LW1C100M	ELECTRO 10UF 16WV		
C24			CK73FB1H331K	CHIP C 330PF K		
C25			CC73FCH1H181J	CHIP C 180PF J		
C26			CK73FB1H183K	CHIP C 0.018UF K		
C27			CE04HW1E4R7M	NP-ELEC 4.7UF 25WV		
C28, 29			C90-3240-05	ELECTRO 2.2UF 35WV		
C30, 31			CK73FB1H223K	CHIP C 0.022UF K		
C32			CE04LW1C100M	ELECTRO 10UF 16WV		
C36			CK73FB1H103K	CHIP C 0.010UF K		
C37, 38			C90-3217-05	ELECTRO 10UF 10WV		
C39			CC73FCH1H060D	CHIP C 6.0PF D		
C40			CC73FCH1H020C	CHIP C 2.0PF C		
C41			CC73FCH1H220J	CHIP C 22PF J		
C42			CC73FCH1H120J	CHIP C 12PF J		
C43			CC73FCH1H100D	CHIP C 10PF D		
C44			CK73FB1H471K	CHIP C 470PF K		
C45			CC73FCH1H220J	CHIP C 22PF J		
C46			CE04LW1C100M	ELECTRO 10UF 16WV		
C47			CK73FB1H102K	CHIP C 1000PF K		
C48			CE04LW1C470M	ELECTRO 47UF 16WV		
C49			CE04LW1H2R2M	ELECTRO 2.2UF 50WV		
C50			CC73FSL1H101J	CHIP C 100PF J		
C51			CK73FB1H471K	CHIP C 470PF K		
C52			CC73FSL1H101J	CHIP C 100PF J		
C70, 71			CK73FB1H822K	CHIP C 8200PF K		
C72			CE04LW1H010M	ELECTRO 1.0UF 50WV		
C73			CE04LW1C470M	ELECTRO 47UF 16WV		
C75			CC73FCH1H040C	CHIP C 4.0PF C		
C76			CC73FCH1H470J	CHIP C 47PF J		
C78			CK73FB1H223K	CHIP C 0.022UF K		
C79, 80			CK73FB1H472K	CHIP C 4700PF K		
C81			CK73FF1C105Z	CHIP C 1.0UF Z		
C82			CK73FB1H103K	CHIP C 0.010UF K		
C83			CC73FSL1H101J	CHIP C 100PF J		
C84, 85			CK73FB1H223K	CHIP C 0.022UF K		
C86			CK73FB1H471K	CHIP C 470PF K		
CN1			E40-9831-05	SOCKET FOR PIN ASSY		
CN2			E40-4871-05	PIN ASSY		
J1	2C		E20-0321-05	LOCK TERMINAL BOARD(2P,F)		
J1	2C		E70-0052-05	LOCK TERMINAL BOARD		
CF1, 2			L72-0536-05	CERAMIC FILTER		
L1			L39-1366-05	COMBINATION COIL		
L2			L40-1091-17	SMALL FIXED INDUCTOR(1UH)		
L3			L30-0911-05	AM IFT		
L4			L30-0950-05	FM IFT		
L5			L30-0951-05	FM IFT		
L6, 7			L79-1239-05	LC FILTER		
L9			L40-1001-17	SMALL FIXED INDUCTOR(10UH,K)		
X1			L77-2232-05	CRYSTAL RESONATOR		
R1			RK73FB2A101J	CHIP R 100 J 1/10W		
R3			RK73FB2A332J	CHIP R 3.3K J 1/10W		
R4			RK73FB2A681J	CHIP R 680 J 1/10W		

L : Scandinavia K : USA P : Canada R : Mexico C : China I : Malaysia
 Y : PX(Far East, Hawaii) T : Europe E : Europe G : Germany V : China(Shanghai)
 Y : AAFES(Europe) X : Australia Q : Russia H : Korea M : Other Areas Δ indicates safety critical components.

* New Parts

Parts without **Parts No.** are not supplied.
Les articles non mentionnes dans le **Parts No.** ne sont pas fournis.
Teile ohne **Parts No.** werden nicht geliefert.

4

Ref. No	Add-ress	New Parts	Parts No.	Description	Desti-nation	Re-marks
R5			RK73FB2A332J	CHIP R 3.3K J 1/10W		
R6			RK73FB2A221J	CHIP R 220 J 1/10W		
R7			RK73FB2A821J	CHIP R 820 J 1/10W		
R8			RK73FB2A100J	CHIP R 10 J 1/10W		
R9			RK73FB2A391J	CHIP R 390 J 1/10W		
R10			RK73FB2A102J	CHIP R 1.0K J 1/10W		
R11			RK73FB2A220J	CHIP R 22 J 1/10W		
R12			RK73FB2A101J	CHIP R 100 J 1/10W		
R14			RK73FB2A101J	CHIP R 100 J 1/10W		
R15			RK73FB2A333J	CHIP R 33K J 1/10W		
R16			RK73FB2A220J	CHIP R 22 J 1/10W		
R17			RK73FB2A362J	CHIP R 3.6K J 1/10W		
R18			RK73FB2A302J	CHIP R 3.0K J 1/10W		
R19			RK73FB2A822J	CHIP R 8.2K J 1/10W		
R20			RK73FB2A392J	CHIP R 3.9K J 1/10W		
R23			RK73FB2A153J	CHIP R 15K J 1/10W		
R25			RK73FB2A273J	CHIP R 27K J 1/10W		
R27, 28			RK73FB2A432J	CHIP R 4.3K J 1/10W		
R33, 34			RK73FB2A102J	CHIP R 1.0K J 1/10W		
R35			RK73FB2A101J	CHIP R 100 J 1/10W		
R36			RK73FB2A102J	CHIP R 1.0K J 1/10W		
R37			RK73FB2A392J	CHIP R 3.9K J 1/10W		
R38			RK73FB2A102J	CHIP R 1.0K J 1/10W		
R39			RK73FB2A103J	CHIP R 10K J 1/10W		
R42			RK73FB2A103J	CHIP R 10K J 1/10W		
R43			RK73FB2A221J	CHIP R 220 J 1/10W		
R44			RD14NB2E271J	RD 270 J 1/4W		
R45			RK73EB2B102J	CHIP R 1.0K J 1/8W		
R46			RK73FB2A102J	CHIP R 1.0K J 1/10W		
R47			RK73EB2B102J	CHIP R 1.0K J 1/8W		
R48			RK73FB2A102J	CHIP R 1.0K J 1/10W		
R49			RK73FB2A103J	CHIP R 10K J 1/10W		
R50			RD14NB2E471J	RD 470 J 1/4W		
R51			RK73FB2A562J	CHIP R 5.6K J 1/10W		
R52			RK73FB2A101J	CHIP R 100 J 1/10W		
R53			RK73FB2A222J	CHIP R 2.2K J 1/10W		
R54			RK73FB2A102J	CHIP R 1.0K J 1/10W		
R55			RK73FB2A333J	CHIP R 33K J 1/10W		
R56, 57			RK73FB2A102J	CHIP R 1.0K J 1/10W		
R58			RK73FB2A123J	CHIP R 12K J 1/10W		
R59			RK73FB2A122J	CHIP R 1.2K J 1/10W		
R72, 73			RK73FB2A392J	CHIP R 3.9K J 1/10W		
R74			RK73FB2A473J	CHIP R 47K J 1/10W		
R75			RK73FB2A822J	CHIP R 8.2K J 1/10W		
R76			RK73FB2A182J	CHIP R 1.8K J 1/10W		
R78			RK73FB2A821J	CHIP R 820 J 1/10W		
R80			RK73FB2A223J	CHIP R 22K J 1/10W		
R81			RS14KB3A151J	FL-PROOF RS 150 J 1W		
R82			RK73FB2A272J	CHIP R 2.7K J 1/10W		
R83			RK73FB2A102J	CHIP R 1.0K J 1/10W		
R84			RK73EB2B102J	CHIP R 1.0K J 1/8W		
R85-87			RK73FB2A105J	CHIP R 1.0M J 1/10W		
R88			RK73FB2A563J	CHIP R 56K J 1/10W		
VR1			R32-0037-05	SEMI FIXED VARIABLE RESISTOR		
W51, 52			R92-0670-05	CHIP R 0 OHM		

L : Scandinavia K : USA P : Canada R : Mexico C : China I : Malaysia
 Y : PX(Far East, Hawaii) T : Europe E : Europe G : Germany V : China(Shanghai)
 Y : AAFES(Europe) X : Australia Q : Russia H : Korea M : Other Areas Δ indicates safety critical components.

* New Parts

Parts without **Parts No.** are not supplied.Les articles non mentionnés dans le **Parts No.** ne sont pas fournis.Teile ohne **Parts No.** werden nicht geliefert.

5

Ref. No	Add-ress	New Parts	Parts No.	Description	Desti-nation	Re-marks
W54, 55			R92-0670-05	CHIP R 0 OHM		
W57			R92-0670-05	CHIP R 0 OHM	ET1X1	
W57-60			R92-0670-05	CHIP R 0 OHM		
W59, 60			R92-0670-05	CHIP R 0 OHM	ET1X1	
W80			R92-0679-05	CHIP R 0 OHM		
W84-86			R92-0679-05	CHIP R 0 OHM		
W84, 85			R92-0679-05	CHIP R 0 OHM	Q1 ET1X1	
D1			DA204U	DIODE		
D1			MA143A	DIODE		
D1			1SS302	DIODE		
D3			HZS8.2N(B2)	ZENER DIODE		
D3			MTZJ8.2(B)	ZENER DIODE		
D4			HZS5.1N(B2)	ZENER DIODE		
D4			MTZJ5.1(B)	ZENER DIODE		
D5			HZS2.7N(B2)	ZENER DIODE		
D5			MTZJ2.7(B)	ZENER DIODE		
D8			MA111	DIODE		
D9			HZS3.3N(B2)	ZENER DIODE		
D9			MTZJ3.3(B)	ZENER DIODE		
D11			MA111	DIODE		
D13			MA111	DIODE		
IC1			LA1837	ANALOGUE IC		
IC2			LC72131	MOS-IC		
Q1			2SC4081(R,S)	TRANSISTOR		
Q1			2SD1819A(Q,R)	TRANSISTOR		
Q2			2SA1576A(R,S)	TRANSISTOR		
Q2			2SB1218A(Q,R)	TRANSISTOR		
Q6, 7			2SC4081(R,S)	TRANSISTOR		
Q6, 7			2SD1819A(Q,R)	TRANSISTOR		
Q10, 11			2SD1757K	TRANSISTOR		
Q12			2SA1576A(R,S)	TRANSISTOR		
Q12			2SB1218A(Q,R)	TRANSISTOR		
Q14			2SA1576A(R,S)	TRANSISTOR		
Q14			2SB1218A(Q,R)	TRANSISTOR		
A1			W02-2584-05	FM FRONT-END ASSY	ET1X1	
A1			W02-2586-05	FM FRONT-END ASSY	Q1	
SURROUND (X08-2952-70)						
C1-4			CK73FB1H103K	CHIP C 0.010UF K		
C5, 6			CC73FSL1H102J	CHIP C 1000PF J		
C7-9			CK73FB1H103K	CHIP C 0.010UF K		
C10			CC73FSL1H331J	CHIP C 330PF J		
C11, 12			CC73FCH1H150J	CHIP C 15PF J		
C13, 14			CC73FCH1H180J	CHIP C 18PF J		
C15			CK73FB1H103K	CHIP C 0.010UF K		
C16			CK73FB1E104K	CHIP C 0.10UF K		
C17			CK73FB1H103K	CHIP C 0.010UF K		
C18			CC73FSL1H102J	CHIP C 1000PF J		
C19			CK73FB1H103K	CHIP C 0.010UF K		
C20			CE04KW1H4R7M	ELECTRO 4.7UF 50WV		
C21			CC73FCH1H330J	CHIP C 33PF J		
C22, 23			CC73FCH1H120J	CHIP C 12PF J		
C24, 25			CC73FCH1H150J	CHIP C 15PF J		
C26			CE04KW1E470M	ELECTRO 47UF 25WV		

L : Scandinavia K : USA P : Canada R : Mexico C : China I : Malaysia

Y : PX(Far East, Hawaii) T : Europe E : Europe G : Germany V : China(Shanghai)

Y : AAFES(Europe) X : Australia Q : Russia H : Korea M : Other Areas ▲ indicates safety critical components.

* New Parts

Parts without **Parts No.** are not supplied.Les articles non mentionnés dans le **Parts No.** ne sont pas fournis.Teile ohne **Parts No.** werden nicht geliefert.

6

Ref. No	Add-ress	New Parts	Parts No.	Description	Desti-nation	Re-marks
C27			CK73FB1E104K	CHIP C 0.10UF K		
C28			CC73FSL1H470J	CHIP C 47PF J		
C29			CC73FCH1H220J	CHIP C 22PF J		
C30			CK73FB1H103K	CHIP C 0.010UF K		
C31, 32			CK73FB1E104K	CHIP C 0.10UF K		
C33, 34			CC73FCH1H220J	CHIP C 22PF J		
C35			CC73FSL1H102J	CHIP C 1000PF J		
C36			CK73FB1H822K	CHIP C 8200PF K		
C37			CK73FB1H103K	CHIP C 0.010UF K		
C38			CE04KW1H2R2M	ELECTRO 2.2UF 50WV		
C39			CK73FB1E104K	CHIP C 0.10UF K		
C50-52			CE04KW1C100M	ELECTRO 10UF 16WV		
C55			CC73FSL1H470J	CHIP C 47PF J		
C56			CE04KW0J471M	ELECTRO 470UF 6.3WV		
C57			CE04KW1A470M	ELECTRO 47UF 10WV		
C58, 59			CK73FB1H103K	CHIP C 0.010UF K		
C60, 61			CC73FSL1H221J	CHIP C 220PF J		
C63			CC73FSL1H470J	CHIP C 47PF J		
C70			CE04KW1C102M	ELECTRO 1000UF 16WV		
C72, 73			CK73FF1C224Z	CHIP C 0.22UF Z		
C77, 78			CK73FB1E104K	CHIP C 0.10UF K		
C81			CE04KW1C101M	ELECTRO 100UF 16WV		
C83			CE04KW1A101M	ELECTRO 100UF 10WV		
C86, 87			CK73FB1E104K	CHIP C 0.10UF K		
C91			CE04KW1C101M	ELECTRO 100UF 16WV		
C92			CE04KW1A101M	ELECTRO 100UF 10WV		
C93-95			CK73FB1E104K	CHIP C 0.10UF K		
C96			CE04KW1C101M	ELECTRO 100UF 16WV		
C97			CE04KW1A101M	ELECTRO 100UF 10WV		
C101, 102			CC73FCH1H220J	CHIP C 22PF J		
C103-106			CC73FSL1H101J	CHIP C 100PF J		
C107, 108			CC73FSL1H681J	CHIP C 680PF J		
C109			CK73FB1H103K	CHIP C 0.010UF K		
C110			CC73FSL1H101J	CHIP C 100PF J		
C111, 112			CE04KW1H100M	ELECTRO 10UF 50WV		
C113-120			CC73FSL1H101J	CHIP C 100PF J		
C121, 122			CE04KW1H4R7M	ELECTRO 4.7UF 50WV		
C123, 124			CC73FSL1H102J	CHIP C 1000PF J		
C125, 126			CK73FB1H682K	CHIP C 6800PF K		
C127, 128			CK73FB1H182K	CHIP C 1800PF K		
C129			CK73FB1H103K	CHIP C 0.010UF K		
C130			CC73FSL1H101J	CHIP C 100PF J		
C131, 132			CE04KW1H4R7M	ELECTRO 4.7UF 50WV		
C133, 134			CC73FSL1H102J	CHIP C 1000PF J		
C135-138			CC73FSL1H101J	CHIP C 100PF J		
C139, 140			CK73FB1H182K	CHIP C 1800PF K		
C141, 142			CC73FSL1H101J	CHIP C 100PF J		
C143, 144			CK73FB1H682K	CHIP C 6800PF K		
C145			CK73FB1H103K	CHIP C 0.010UF K		
C146-150			CC73FSL1H101J	CHIP C 100PF J		
C151, 152			CE04KW1H4R7M	ELECTRO 4.7UF 50WV		
C153, 154			CC73FSL1H102J	CHIP C 1000PF J		
C155-158			CC73FSL1H101J	CHIP C 100PF J		
C159, 160			CK73FB1H182K	CHIP C 1800PF K		
C161, 162			CC73FSL1H101J	CHIP C 100PF J		

L : Scandinavia K : USA P : Canada R : Mexico C : China I : Malaysia

Y : PX(Far East, Hawaii) T : Europe E : Europe G : Germany V : China(Shanghai)

Y : AAFES(Europe) X : Australia Q : Russia H : Korea M : Other Areas ▲ indicates safety critical components.

PARTS LIST

KRF-V8010D/V8010DW

* New Parts

Parts without **Parts No.** are not supplied.Les articles non mentionnés dans le **Parts No.** ne sont pas fournis.Teile ohne **Parts No.** werden nicht geliefert.

7

Ref. No	Add-ress	New Parts	Parts No.	Description	Desti-nation	Re-marks
C163, 164			CK73FB1H682K	CHIP C 6800PF K		
C165			CK73FB1H103K	CHIP C 0.010UF K		
C166			CC73FSL1H101J	CHIP C 100PF J		
C167			CE04KW1H220M	ELECTRO 22UF 50WV		
C168-170			CK73FB1H103K	CHIP C 0.010UF K		
C171-174			CQ93FMG1H823J	MYLAR 0.082UF J		
C175-178			CC73FSL1H101J	CHIP C 100PF J		
C179			CK73FB1H103K	CHIP C 0.010UF K		
C180			CC73FSL1H101J	CHIP C 100PF J		
C181, 182			CE04KW1E470M	ELECTRO 47UF 25WV		
C183, 184			CE04KW1H220M	ELECTRO 22UF 50WV		
C185, 186			CC73FSL1H101J	CHIP C 100PF J		
C187			CK73FB1H103K	CHIP C 0.010UF K		
C188			CC73FSL1H101J	CHIP C 100PF J		
C191-194			CQ93FMG1H823J	MYLAR 0.082UF J		
C195-198			CC73FSL1H101J	CHIP C 100PF J		
C199			CK73FB1H103K	CHIP C 0.010UF K		
C200			CC73FSL1H101J	CHIP C 100PF J		
C201, 202			CQ93FMG1H823J	MYLAR 0.082UF J		
C203-206			CC73FSL1H101J	CHIP C 100PF J		
C207			CQ93FMG1H104J	MYLAR 0.10UF J		
C208			CC73FSL1H101J	CHIP C 100PF J		
C209			CQ93FMG1H154J	MYLAR 0.15UF J		
C210			CC73FSL1H101J	CHIP C 100PF J		
C211			CQ93FMG1H393J	MYLAR 0.039UF J		
C212			CC73FSL1H101J	CHIP C 100PF J		
C213			CE04KW1H2R2M	ELECTRO 2.2UF 50WV		
C214			CK73FB1H103K	CHIP C 0.010UF K		
C216, 217			CC73FSL1H101J	CHIP C 100PF J		
C218			CE04KW1H2R2M	ELECTRO 2.2UF 50WV		
C219, 220			CK73FB1H103K	CHIP C 0.010UF K		
C223, 224			CC73FSL1H102J	CHIP C 1000PF J		
C225			CE04KW1H220M	ELECTRO 22UF 50WV		
C226-230			CE04KW1H4R7M	ELECTRO 4.7UF 50WV		
C231			CE04KW1C100M	ELECTRO 10UF 16WV		
C300			CK73FB1E104K	CHIP C 0.10UF K		
C301, 302			CC73FSL1H221J	CHIP C 220PF J		
C303, 304			CE04KW1H4R7M	ELECTRO 4.7UF 50WV		
C305-308			CC73FSL1H101J	CHIP C 100PF J		
C311, 312			CC73FSL1H221J	CHIP C 220PF J		
C313, 314			CE04KW1H4R7M	ELECTRO 4.7UF 50WV		
C315-318			CC73FSL1H101J	CHIP C 100PF J		
C320			CK73FB1H103K	CHIP C 0.010UF K		
C322			CC73FSL1H101J	CHIP C 100PF J		
CN1			E40-8253-05	FLAT CABLE CONNECTOR		
CN2			E40-3256-05	PIN ASSY		
CN3			E40-4248-05	PIN ASSY		
J1	1C		E63-0199-05	PHONO JACK		
J2	1C		E63-0094-05	PHONO JACK		
J3	1C		E63-0093-05	PHONO JACK		
J4	1C		E11-0293-05	MINIATURE PHONE JACK(2P)		
J5	1C		E63-0114-05	PHONO JACK		
E1			J11-0808-05	WIRE CLAMPER		

L : Scandinavia K : USA P : Canada R : Mexico C : China I : Malaysia
 Y : PX(Far East, Hawaii) T : Europe E : Europe G : Germany V : China(Shanghai)
 Y : AAFES(Europe) X : Australia Q : Russia H : Korea M : Other Areas Δ indicates safety critical components.

* New Parts

Parts without **Parts No.** are not supplied.Les articles non mentionnés dans le **Parts No.** ne sont pas fournis.Teile ohne **Parts No.** werden nicht geliefert.

8

Ref. No	Add-ress	New Parts	Parts No.	Description	Desti-nation	Re-marks
L1			L92-0044-05	FERRITE CORE		
L2			L79-1216-05	LINE FILTER		
L3			L92-0044-05	FERRITE CORE		
L4, 5			L79-1216-05	LINE FILTER		
X1			L77-2220-05	CRYSTAL RESONATOR(10MHZ)		
X2			L77-2221-05	CRYSTAL RESONATOR(12.288MHZ)		
R1			RK73FB2A105J	CHIP R 1.0M J 1/10W		
R2			RK73FB2A821J	CHIP R 820 J 1/10W		
R3			RK73FB2A201J	CHIP R 200 J 1/10W		
R4			RK73FB2A183J	CHIP R 18K J 1/10W		
R5-15			RK73FB2A221J	CHIP R 220 J 1/10W		
R16			RK73FB2A104J	CHIP R 100K J 1/10W		
R17, 18			RK73FB2A102J	CHIP R 1.0K J 1/10W		
R19			RK73FB2A221J	CHIP R 220 J 1/10W		
R20			RK73FB2A104J	CHIP R 100K J 1/10W		
R21			RK73FB2A221J	CHIP R 220 J 1/10W		
R22			RK73FB2A102J	CHIP R 1.0K J 1/10W		
R23, 24			RK73FB2A221J	CHIP R 220 J 1/10W		
R25-27			RK73FB2A222J	CHIP R 2.2K J 1/10W		
R28			RK73FB2A105J	CHIP R 1.0M J 1/10W		
R29			RK73FB2A750J	CHIP R 75 J 1/10W		
R30			RK73FB2A472J	CHIP R 4.7K J 1/10W		
R31			RK73FB2A473J	CHIP R 47K J 1/10W		
R32			RK73FB2A472J	CHIP R 4.7K J 1/10W		
R33-36			RK73FB2A102J	CHIP R 1.0K J 1/10W		
R37			RK73FB2A473J	CHIP R 47K J 1/10W		
R50			RK73FB2A750J	CHIP R 75 J 1/10W		
R51			RK73FB2A332J	CHIP R 3.3K J 1/10W		
R52, 53			RK73FB2A750J	CHIP R 75 J 1/10W		
R54			RK73FB2A332J	CHIP R 3.3K J 1/10W		
R55, 56			RK73FB2A750J	CHIP R 75 J 1/10W		
Δ R57, 58			RS14KB3A391J	FL-PROOF RS 390 J 1W		
R59			RD14NB2E1R0J	RD 1 J 1/4W		
R61			RD14NB2E2R2J	RD 2.2 J 1/4W		
Δ R62, 63			RD14NB2E100J	RD 10 J 1/4W		
Δ R64			RD14NB2E1R0J	RD 1 J 1/4W		
Δ R66			RD14NB2E2R2J	RD 2.2 J 1/4W		
Δ R67			RD14NB2E1R0J	RD 1 J 1/4W		
Δ R68			RD14NB2E2R2J	RD 2.2 J 1/4W		
R69			RK73FB2A203J	CHIP R 20K J 1/10W		
R70			RK73FB2A101J	CHIP R 100 J 1/10W		
R71			RK73FB2A473J	CHIP R 47K J 1/10W		
R72			RK73FB2A472J	CHIP R 4.7K J 1/10W		
R101-104			RK73FB2A203J	CHIP R 20K J 1/10W		
R105, 106			RK73FB2A101J	CHIP R 100 J 1/10W		
R107, 108			RK73FB2A102J	CHIP R 1.0K J 1/10W		
R111, 112			RK73FB2A104J	CHIP R 100K J 1/10W		
R113, 114			RK73FB2A512J	CHIP R 5.1K J 1/10W		
R115, 116			RK73FB2A101J	CHIP R 100 J 1/10W		
R117-120			RK73FB2A162J	CHIP R 1.6K J 1/10W		
R121, 122			RK73FB2A101J	CHIP R 100 J 1/10W		
R131, 132			RK73FB2A104J	CHIP R 100K J 1/10W		
R133, 134			RK73FB2A512J	CHIP R 5.1K J 1/10W		
R135, 136			RK73FB2A432J	CHIP R 4.3K J 1/10W		

L : Scandinavia K : USA P : Canada R : Mexico C : China I : Malaysia
 Y : PX(Far East, Hawaii) T : Europe E : Europe G : Germany V : China(Shanghai)
 Y : AAFES(Europe) X : Australia Q : Russia H : Korea M : Other Areas Δ indicates safety critical components.

PARTS LIST

KRF-V8010D/V8010DW

* New Parts

Parts without **Parts No.** are not supplied.
Les articles non mentionnés dans le **Parts No.** ne sont pas fournis.
Teile ohne **Parts No.** werden nicht geliefert.

9

Ref. No	Add-ress	New Parts	Parts No.	Description	Desti-nation	Re-marks
R137, 138			RK73FB2A392J	CHIP R 3.9K J 1/10W		
R139-142			RK73FB2A162J	CHIP R 1.6K J 1/10W		
R143, 144			RK73FB2A101J	CHIP R 100 J 1/10W		
R151, 152			RK73FB2A104J	CHIP R 100K J 1/10W		
R153, 154			RK73FB2A512J	CHIP R 5.1K J 1/10W		
R155, 156			RK73FB2A432J	CHIP R 4.3K J 1/10W		
R157, 158			RK73FB2A392J	CHIP R 3.9K J 1/10W		
R159-162			RK73FB2A162J	CHIP R 1.6K J 1/10W		
R163, 164			RK73FB2A101J	CHIP R 100 J 1/10W		
R173, 174			RK73FB2A153J	CHIP R 15K J 1/10W		
R175, 176			RK73FB2A303J	CHIP R 30K J 1/10W		
R177, 178			RK73FB2A101J	CHIP R 100 J 1/10W		
R181, 182			RK73FB2A104J	CHIP R 100K J 1/10W		
R183, 184			RK73FB2A101J	CHIP R 100 J 1/10W		
R185-188			RK73FB2A392J	CHIP R 3.9K J 1/10W		
R189-192			RK73FB2A222J	CHIP R 2.2K J 1/10W		
R193, 194			RK73FB2A101J	CHIP R 100 J 1/10W		
R195, 196			RK73FB2A224J	CHIP R 220K J 1/10W		
R201, 202			RK73FB2A153J	CHIP R 15K J 1/10W		
R203, 204			RK73FB2A303J	CHIP R 30K J 1/10W		
R205			RK73FB2A153J	CHIP R 15K J 1/10W		
R206			RK73FB2A303J	CHIP R 30K J 1/10W		
R207			RK73FB2A123J	CHIP R 12K J 1/10W		
R208-210			RK73FB2A163J	CHIP R 16K J 1/10W		
R211-214			RK73FB2A101J	CHIP R 100 J 1/10W		
R215, 216			RK73FB2A224J	CHIP R 220K J 1/10W		
R217-220			RK73FB2A101J	CHIP R 100 J 1/10W		
R221, 222			RK73FB2A203J	CHIP R 20K J 1/10W		
R223-225			RK73FB2A393J	CHIP R 39K J 1/10W		
R226			RK73FB2A123J	CHIP R 12K J 1/10W		
R301, 302			RK73FB2A102J	CHIP R 1.0K J 1/10W		
R303-306			RK73FB2A224J	CHIP R 220K J 1/10W		
R307, 308			RK73FB2A101J	CHIP R 100 J 1/10W		
R311, 312			RK73FB2A102J	CHIP R 1.0K J 1/10W		
R313-316			RK73FB2A224J	CHIP R 220K J 1/10W		
R317			RK73FB2A101J	CHIP R 100 J 1/10W		
R318			RK73FB2A103J	CHIP R 10K J 1/10W		
R320			RK73FB2A103J	CHIP R 10K J 1/10W		
S1	1C		S62-0034-05	SLIDE SWITCH		
D1, 2			DA204J	DIODE		
D1, 2			1SS302	DIODE		
D3, 4			UDZ5.1B	ZENER DIODE		
D5			D2SBA20F03	DIODE		
D7-9			UDZ6.2B	ZENER DIODE		
IC1			YSS248	MOS-IC		
IC2			CS4226KQG	MOS-IC		
IC3			TC74HCU04AF	IC(HEX INVERTER SMD)		
IC4			NJM2279M	ANALOGUE IC		
IC5			TC9162AF	MOS-IC		
IC6			TC9164AF	MOS-IC		
IC8-10			TA7805SB	ANALOGUE IC		
IC11-23			NJM4565M	IC(OP AMP X2)		
IC24			TC7W241FU	MOS-IC		
IC31, 32			NJM4565M	IC(OP AMP X2)		

L: Scandinavia K: USA P: Canada R: Mexico C: China I: Malaysia
Y: PX(Far East, Hawaii) T: Europe E: Europe G: Germany V: China(Shanghai)
Y: AAFES(Europe) X: Australia Q: Russia H: Korea M: Other Areas Δ indicates safety critical components.

* New Parts

Parts without **Parts No.** are not supplied.
Les articles non mentionnés dans le **Parts No.** ne sont pas fournis.
Teile ohne **Parts No.** werden nicht geliefert.

10

Ref. No	Add-ress	New Parts	Parts No.	Description	Desti-nation	Re-marks
Q1			2SC4081(R,S)	TRANSISTOR		
Q1			2SC4116(Y,GR)	TRANSISTOR		
Q2			2SA1576A(R,S)	TRANSISTOR		
Q2			2SA1586(Y,GR)	TRANSISTOR		
A1			W02-1181-05	OPTIC RECEIVING MODULE		
AUDIO (X09-6092-71)						
D500-502			B30-2513-05	LED(RED)		
D527			B30-2513-05	LED(RED)		
C1, 2			CQ93FMG1H224J	MYLAR 0.22UF J		ET1Q1
C3			C91-1480-05	MP 0.22UF 250WV		X1
C5, 6			C90-3760-05	ELECTRO 4700UF 75WV		X1
C5, 6			C90-3762-05	ELECTRO 4700UF 63WV		ET1Q1
C7, 8			C90-3763-05	ELECTRO 3300UF 35WV		ET1Q1
C7, 8			C90-3776-05	ELECTRO 3300UF 42WV		X1
C9			CE04KW1V222M	ELECTRO 2200UF 35WV		
C10			CE04KW1V471M	ELECTRO 470UF 35WV		
C11-14			CK73FF1C224Z	CHIP C 0.22UF Z		
C15, 16			CE04KW1E101M	ELECTRO 100UF 25WV		
C18			CE04KW1J220M	ELECTRO 22UF 63WV		
C19			CE04KW1V470M	ELECTRO 47UF 35WV		
C21, 22			CE04KW1H470M	ELECTRO 47UF 50WV		
C23-26			CE04KW2A100M	ELECTRO 10UF 100WV		
C27, 28			CC73FSL1H151J	CHIP C 150PF J		
C29, 30			CE04KW1H470M	ELECTRO 47UF 50WV		
C31, 32			CE04KW2A100M	ELECTRO 10UF 100WV		
C33, 34			CK45FB2H392K	CERAMIC 3900PF K		
C35			CE04KW0J221M	ELECTRO 220UF 6.3WV		
C36			CE04KW1V4R7M	ELECTRO 4.7UF 35WV		
C37			CE04KW1H010M	ELECTRO 1.0UF 50WV		
C38			CE04HW1E100M	NP-ELEC 10UF 25WV		
C39, 40			CK45FB2H392K	CERAMIC 3900PF K		
C41			CE04KW1A101M	ELECTRO 100UF 10WV		
C42			CE04KW1C330M	ELECTRO 33UF 16WV		
C101, 102			CC73FSL1H390J	CHIP C 39PF J		
C103, 104			CE04KW1H100M	ELECTRO 10UF 50WV		
C105, 106			CC73FSL1H221J	CHIP C 220PF J		
C107, 108			CE04KW1A470M	ELECTRO 47UF 10WV		
C109, 110			CC45FSL1H101J	CERAMIC 100PF J		
C111, 112			CQ93FMG1H123J	MYLAR 0.012UF J		
C113, 114			CK45FB1H332K	CERAMIC 3300PF K		
C115, 116			CE04KW1V4R7M	ELECTRO 4.7UF 35WV		
C117			CC45FSL1H101J	CERAMIC 100PF J		
C118			CK45FF1H103Z	CERAMIC 0.010UF Z		
C119, 120			CC73FSL1H221J	CHIP C 220PF J		
C121, 122			CC73FSL1H151J	CHIP C 150PF J		
C123, 124			CC73FSL1H221J	CHIP C 220PF J		
C127, 128			CC73FSL1H221J	CHIP C 220PF J		
C131, 132			CC73FSL1H221J	CHIP C 220PF J		
C135, 136			CC73FSL1H221J	CHIP C 220PF J		
C139, 140			CC73FSL1H221J	CHIP C 220PF J		
C143, 144			CC73FSL1H221J	CHIP C 220PF J		
C147, 148			CC73FSL1H221J	CHIP C 220PF J		
C151, 152			CC73FSL1H221J	CHIP C 220PF J		

L: Scandinavia K: USA P: Canada R: Mexico C: China I: Malaysia
Y: PX(Far East, Hawaii) T: Europe E: Europe G: Germany V: China(Shanghai)
Y: AAFES(Europe) X: Australia Q: Russia H: Korea M: Other Areas Δ indicates safety critical components.

PARTS LIST

KRF-V8010D/V8010DW

* New Parts
Parts without **Parts No.** are not supplied.
Les articles non mentionnés dans le **Parts No.** ne sont pas fournis.
Teile ohne **Parts No.** werden nicht geliefert.

11

Ref. No	Add-ress	New Parts	Parts No.	Description	Desti-nation	Re-marks
C155, 156 C157-162 C163, 164 C165 C166-168			CE04KW1H2R2M CC73FSL1H101J CE04KW1C220M CC45FSL1H101J CK45FF1H103Z	ELECTRO 2.2UF 50WV CHIP C 100PF J ELECTRO 22UF 16WV CERAMIC 100PF J CERAMIC 0.010UF Z		
C169, 170 C171, 172 C200 C201 C202			CC73FSL1H221J CK45FF1H103Z CE04KW1H010M CE04KW1HR33M CQ93FMG1H153J	CHIP C 220PF J CERAMIC 0.010UF Z ELECTRO 1.0UF 50WV ELECTRO 0.33UF 50WV MYLAR 0.015UF J		
C203, 204 C205, 206 C207-210 C211 C212			CE04KW1V4R7M CK73FB1H222K CC73FSL1H101J CQ93FMG1H822J CC73FSL1H221J	ELECTRO 4.7UF 35WV CHIP C 2200PF K CHIP C 100PF J MYLAR 8200PF J CHIP C 220PF J		
C219 C220 C221 C223, 224 C226-228			CQ93FMG1H822J CQ93FMG1H153J CE04KW1HR33M CE04KW1C100M CE04KW1V4R7M	MYLAR 8200PF J MYLAR 0.015UF J ELECTRO 0.33UF 50WV ELECTRO 10UF 16WV ELECTRO 4.7UF 35WV		
C229, 230 C233, 234 C237 C238 C239, 240			CC73FSL1H471J CC73FSL1H101J CC45FSL1H101J CK45FF1H103Z CE04KW1V4R7M	CHIP C 470PF J CHIP C 100PF J CERAMIC 100PF J CERAMIC 0.010UF Z ELECTRO 4.7UF 35WV		
C241, 242 C245, 246 C251, 252 C253, 254 C257, 258			CC73FSL1H471J CC73FSL1H101J CE04KW1V4R7M CC73FSL1H471J CC73FSL1H101J	CHIP C 470PF J CHIP C 100PF J ELECTRO 4.7UF 35WV CHIP C 470PF J CHIP C 100PF J		
C263, 264 C265, 266 C267, 268 C271, 272 C273, 274			CC73FSL1H821J CE04KW1H2R2M CE04KW1A101M CE04KW1H2R2M CE04KW1A101M	CHIP C 820PF J ELECTRO 2.2UF 50WV ELECTRO 100UF 10WV ELECTRO 2.2UF 50WV ELECTRO 100UF 10WV		
C277 C279 C281, 282 C283-285 C287, 288			CE04KW1H2R2M CE04KW1A101M CC45FCH1H100D CC45FCH1H150J CK73FB1H102K	ELECTRO 2.2UF 50WV ELECTRO 100UF 10WV CERAMIC 10PF D CERAMIC 15PF J CHIP C 1000PF K		
C289, 290 C293, 294 C295, 296 C299 C301			CQ93FMG1H104J CK73FB1H102K CQ93FMG1H104J CK73FB1H102K CQ93FMG1H104J	MYLAR 0.10UF J CHIP C 1000PF K MYLAR 0.10UF J CHIP C 1000PF K MYLAR 0.10UF J		
C305-308 C309-311 C313-316 C319, 320 C321-325			CC45FSL1H101J CK45FF1H472Z CK45FF1H472Z CE04KW1H3R3M CE04KW1H010M	CERAMIC 100PF J CERAMIC 4700PF Z CERAMIC 4700PF Z ELECTRO 3.3UF 50WV ELECTRO 1.0UF 50WV		
C326-328 C329-334 C329, 330 C331-333 C334			CE04KW1H100M CE04KW1C470M CE04KW1C470M CE04KW1V4R7M CE04KW1C470M	ELECTRO 10UF 50WV ELECTRO 47UF 16WV ELECTRO 47UF 16WV ELECTRO 4.7UF 35WV ELECTRO 47UF 16WV		X1 ET1Q1 ET1Q1 ET1Q1

L: Scandinavia K: USA P: Canada R: Mexico C: China I: Malaysia
Y: PX(Far East, Hawaii) T: Europe G: Germany V: China(Shanghai)
Y: AAFES(Europe) X: Australia Q: Russia H: Korea M: Other Areas Δ indicates safety critical components.

* New Parts
Parts without **Parts No.** are not supplied.
Les articles non mentionnés dans le **Parts No.** ne sont pas fournis.
Teile ohne **Parts No.** werden nicht geliefert.

12

Ref. No	Add-ress	New Parts	Parts No.	Description	Desti-nation	Re-marks
C335 C500 C501 C502 C503			CE04KW1H101M CK45FB1H102K CK45FF1H103Z CQ93FMG1H104J CK45FF1H103Z	ELECTRO 100UF 50WV CERAMIC 1000PF K CERAMIC 0.010UF Z MYLAR 0.10UF J CERAMIC 0.010UF Z		
C504 C505 C506 C507 C508, 509			CK73FB1H103K CK45FF1H103Z CK45FB1H102K CK45FF1H103Z CE04KW1A101M	CHIP C 0.010UF K CERAMIC 0.010UF Z CERAMIC 1000PF K CERAMIC 0.010UF Z ELECTRO 100UF 10WV		
C510 C511-513 C514 C515 C516			CC45FSL1H331J CK45FF1H103Z CK73FB1H103K CK45FB1H561K CE04KW1H2R2M	CERAMIC 330PF J CERAMIC 0.010UF Z CHIP C 0.010UF K CERAMIC 560PF K ELECTRO 2.2UF 50WV		
C517 C518-522 C523 C524 C525			CE04KW1H010M CK45FF1H103Z CE04KW1A101M CK45FF1H103Z CE04KW1H010M	ELECTRO 1.0UF 50WV CERAMIC 0.010UF Z ELECTRO 100UF 10WV CERAMIC 0.010UF Z ELECTRO 1.0UF 50WV		
C526 C527 C528 C529, 530 C531			C90-3214-05 CC73FCH1H470J CC73FCH1H180J CE04KW1V4R7M CK73FB1H103K	ELECTRO 100UF 6.3WV CHIP C 47PF J CHIP C 18PF J ELECTRO 4.7UF 35WV CHIP C 0.010UF K		
C532, 533 C534			CK73FB1H102K C90-1827-05	CHIP C 1000PF K ELECTRO 0.047F 5.5WV		
CN1 CN8 CN9 CN11 CN12			E40-4299-05 E40-8251-05 E40-9848-05 E40-8254-05 E40-8196-05	PIN ASSY FLAT CABLE CONNECTOR PIN ASSY FLAT CABLE CONNECTOR PIN ASSY		
CN13 CN51 CN52 CN53 J1			E40-4248-05 E40-8258-05 E40-8253-05 E40-8250-05 E63-0046-15	PIN ASSY FLAT CABLE CONNECTOR FLAT CABLE CONNECTOR FLAT CABLE CONNECTOR PHONO JACK		
J2, 3 J4 J5 J6 J7	2C 2C 2C 2C 2C	*	E63-0047-15 E63-0114-05 E70-0100-05 E70-0047-05 E63-0046-15	PHONO JACK PHONO JACK SCREW TERMINAL BOARD LOCK TERMINAL BOARD PHONO JACK		
W401-405			E29-1634-14	LEAD PLATE		
L1-5 L501 L502 X501 X502			L39-1373-05 L40-1091-17 L40-1001-17 L78-0290-05 L77-2002-05	PHASE COMPENSATION COIL SMALL FIXED INDUCTOR(10UH) SMALL FIXED INDUCTOR(10UH,K) RESONATOR (8MHZ) CRYSTAL RESONATOR(4.332MHZ)		
R1, 2 R3, 4 R5 R6 R8			RK73FB2A513J RK73FB2A273J RK73FB2A222J RK73FB2A333J RK73FB2A152J	CHIP R 51K J 1/10W CHIP R 27K J 1/10W CHIP R 2.2K J 1/10W CHIP R 33K J 1/10W CHIP R 1.5K J 1/10W		X1

L: Scandinavia K: USA P: Canada R: Mexico C: China I: Malaysia
Y: PX(Far East, Hawaii) T: Europe G: Germany V: China(Shanghai)
Y: AAFES(Europe) X: Australia Q: Russia H: Korea M: Other Areas Δ indicates safety critical components.

* New Parts

Parts without **Parts No.** are not supplied.Les articles non mentionnés dans le **Parts No.** ne sont pas fournis.Teile ohne **Parts No.** werden nicht geliefert.

Ref. No	Add-ress	New Parts	Parts No.	Description	Desti-nation	Re-marks
R9, 10			RS14KB3D391J	FL-PROOF RS 390	J 2W	
R11, 12			RK73FB2A472J	CHIP R 4.7K	J 1/10W	
R14			RD14NB2E1R0J	RD 1	J 1/4W	
R16, 17			RK73FB2A273J	CHIP R 27K	J 1/10W	
R18			RD14NB2E4R7J	RD 4.7	J 1/4W	
R19			RK73FB2A472J	CHIP R 4.7K	J 1/10W	
R21, 22			RS14KB3A392J	FL-PROOF RS 3.9K	J 1W	
R23, 24			RD14NB2E103J	RD 10K	J 1/4W	
R25, 26			RS14KB3A392J	FL-PROOF RS 3.9K	J 1W	
R27, 28			RK73FB2A182J	CHIP R 1.8K	J 1/10W	ET1Q1
R27, 28			RK73FB2A272J	CHIP R 2.7K	J 1/10W	X1
R30			RK73FB2A223J	CHIP R 22K	J 1/10W	
R32			RK73FB2A153J	CHIP R 15K	J 1/10W	
R34			RK73FB2A473J	CHIP R 47K	J 1/10W	
R35			RK73FB2A182J	CHIP R 1.8K	J 1/10W	ET1Q1
R35			RK73FB2A272J	CHIP R 2.7K	J 1/10W	X1
R37			RS14KB3A681J	FL-PROOF RS 680	J 1W	
R38-40			RS14KB3D271J	FL-PROOF RS 270	J 2W	
R41			RS14KB3D221J	FL-PROOF RS 220	J 2W	
R42-44			RS14KB3D391J	FL-PROOF RS 390	J 2W	
R45			RD14NB2E1R0J	RD 1	J 1/4W	
R46			RD14NB2E821J	RD 820	J 1/4W	
R50			RK73FB2A472J	CHIP R 4.7K	J 1/10W	
R51			RK73FB2A473J	CHIP R 47K	J 1/10W	
R101, 102			RK73FB2A102J	CHIP R 1.0K	J 1/10W	
R103, 104			RK73FB2A273J	CHIP R 27K	J 1/10W	
R105, 106			RK73FB2A101J	CHIP R 100	J 1/10W	
R117, 118			RK73FB2A102J	CHIP R 1.0K	J 1/10W	
R119, 120			RK73FB2A224J	CHIP R 220K	J 1/10W	
R121, 122			RK73FB2A102J	CHIP R 1.0K	J 1/10W	
R123, 124			RK73FB2A224J	CHIP R 220K	J 1/10W	
R125, 126			RK73FB2A102J	CHIP R 1.0K	J 1/10W	
R127, 128			RK73FB2A224J	CHIP R 220K	J 1/10W	
R129, 130			RK73FB2A102J	CHIP R 1.0K	J 1/10W	
R131, 132			RK73FB2A224J	CHIP R 220K	J 1/10W	
R135, 136			RK73FB2A102J	CHIP R 1.0K	J 1/10W	
R137, 138			RK73FB2A224J	CHIP R 220K	J 1/10W	
R139, 140			RK73FB2A102J	CHIP R 1.0K	J 1/10W	
R141, 142			RK73FB2A224J	CHIP R 220K	J 1/10W	
R143, 144			RK73FB2A102J	CHIP R 1.0K	J 1/10W	
R145, 146			RK73FB2A224J	CHIP R 220K	J 1/10W	
R147, 148			RK73FB2A102J	CHIP R 1.0K	J 1/10W	
R149, 150			RK73FB2A224J	CHIP R 220K	J 1/10W	
R151, 152			RK73FB2A102J	CHIP R 1.0K	J 1/10W	
R153-156			RK73FB2A224J	CHIP R 220K	J 1/10W	
R157, 158			RK73FB2A4R7J	CHIP R 4.7	J 1/10W	
R165-168			RK73FB2A103J	CHIP R 10K	J 1/10W	
R169-172			RK73FB2A223J	CHIP R 22K	J 1/10W	
R173, 174			RK73FB2A473J	CHIP R 47K	J 1/10W	
R175, 176			RK73FB2A622J	CHIP R 6.2K	J 1/10W	
R177, 178			RK73FB2A103J	CHIP R 10K	J 1/10W	
R203, 204			RK73FB2A102J	CHIP R 1.0K	J 1/10W	
R205, 206			RK73FB2A100J	CHIP R 10	J 1/10W	
R219			RS14KB3A221J	FL-PROOF RS 220	J 1W	
R220			RS14KB3A271J	FL-PROOF RS 270	J 1W	

L : Scandinavia

K : USA

P : Canada

R : Mexico

C : China

I : Malaysia

Y : PX(Far East, Hawaii)

T : Europe

E : Europe

G : Germany

V : China(Shanghai)

Y : AAFES(Europe)

X : Australia

Q : Russia

H : Korea

M : Other Areas

Δ indicates safety critical components.

* New Parts

Parts without **Parts No.** are not supplied.Les articles non mentionnés dans le **Parts No.** ne sont pas fournis.Teile ohne **Parts No.** werden nicht geliefert.

Ref. No	Add-ress	New Parts	Parts No.	Description	Desti-nation	Re-marks
R226			RK73FB2A103J	CHIP R 10K	J 1/10W	
R227, 228			RK73FB2A104J	CHIP R 100K	J 1/10W	
R229, 230			RK73FB2A133J	CHIP R 13K	J 1/10W	ET1Q1
R229, 230			RK73FB2A912J	CHIP R 9.1K	J 1/10W	X1
R231, 232			RK73FB2A183J	CHIP R 18K	J 1/10W	
R237, 238			RK73FB2A103J	CHIP R 10K	J 1/10W	
R239, 240			RK73FB2A104J	CHIP R 100K	J 1/10W	
R241, 242			RK73FB2A363J	CHIP R 36K	J 1/10W	X1
R241, 242			RK73FB2A913J	CHIP R 91K	J 1/10W	ET1Q1
R243, 244			RK73FB2A183J	CHIP R 18K	J 1/10W	
R249, 250			RK73FB2A103J	CHIP R 10K	J 1/10W	
R251, 252			RK73FB2A104J	CHIP R 100K	J 1/10W	
R253			RK73FB2A363J	CHIP R 36K	J 1/10W	X1
R253			RK73FB2A913J	CHIP R 91K	J 1/10W	ET1Q1
R254			RK73FB2A432J	CHIP R 4.3K	J 1/10W	
R255, 256			RK73FB2A183J	CHIP R 18K	J 1/10W	
R263, 264			RK73FB2A102J	CHIP R 1.0K	J 1/10W	
R267			RK73FB2A102J	CHIP R 1.0K	J 1/10W	
R269, 270			RK73FB2A102J	CHIP R 1.0K	J 1/10W	
R271			RK73FB2A473J	CHIP R 47K	J 1/10W	
R272			RK73FB2A361J	CHIP R 360	J 1/10W	
R275, 276			RK73FB2A104J	CHIP R 100K	J 1/10W	
R277, 278			RK73FB2A563J	CHIP R 56K	J 1/10W	
R284			RK73FB2A104J	CHIP R 100K	J 1/10W	
R291			RK73FB2A104J	CHIP R 100K	J 1/10W	
R305, 306			RK73FB2A102J	CHIP R 1.0K	J 1/10W	
R309			RK73FB2A102J	CHIP R 1.0K	J 1/10W	
R310			RK73FB2A333J	CHIP R 33K	J 1/10W	
R311, 312			R92-1866-05	METAL FILM 0.1	2W	
R313, 314			RK73FB2A333J	CHIP R 33K	J 1/10W	
R315, 316			RK73FB2A243J	CHIP R 24K	J 1/10W	X1
R315, 316			RK73FB2A273J	CHIP R 27K	J 1/10W	ET1Q1
R317, 318			RK73FB2A471J	CHIP R 470	J 1/10W	
R319, 320			RK73FB2A333J	CHIP R 33K	J 1/10W	
R323, 324			RD14NB2E4R7J	RD 4.7	J 1/4W	
R325, 326			R92-1866-05	METAL FILM 0.1	2W	
R327, 328			RK73FB2A333J	CHIP R 33K	J 1/10W	
R329, 330			RK73FB2A303J	CHIP R 30K	J 1/10W	
R331, 332			RK73FB2A471J	CHIP R 470	J 1/10W	
R333, 334			RK73FB2A333J	CHIP R 33K	J 1/10W	
R337, 338			RD14NB2E4R7J	RD 4.7	J 1/4W	
R339			R92-1866-05	METAL FILM 0.1	2W	
R341			RD14NB2E4R7J	RD 4.7	J 1/4W	
R351, 352			RD14NB2E4R7J	RD 4.7	J 1/4W	
R353			RK73FB2A103J	CHIP R 10K	J 1/10W	
R354			RK73FB2A223J	CHIP R 22K	J 1/10W	
R355			RK73FB2A473J	CHIP R 47K	J 1/10W	
R356, 357			RK73FB2A104J	CHIP R 100K	J 1/10W	
R361			RK73FB2A333J	CHIP R 33K	J 1/10W	
R363			RK73FB2A303J	CHIP R 30K	J 1/10W	
R365			RK73FB2A471J	CHIP R 470	J 1/10W	
R367, 368			RK73FB2A242J	CHIP R 2.4K	J 1/10W	X1
R367, 368			RK73FB2A332J	CHIP R 3.3K	J 1/10W	ET1Q1
R369-371			RK73FB2A562J	CHIP R 5.6K	J 1/10W	X1
R369-371			RK73FB2A682J	CHIP R 6.8K	J 1/10W	ET1Q1

L : Scandinavia

K : USA

P : Canada

R : Mexico

C : China

I : Malaysia

Y : PX(Far East, Hawaii)

T : Europe

E : Europe

G : Germany

V : China(Shanghai)

Y : AAFES(Europe)

X : Australia

Q : Russia

H : Korea

M : Other Areas

Δ indicates safety critical components.

PARTS LIST

KRF-V8010D/V8010DW

* New Parts

Parts without **Parts No.** are not supplied.Les articles non mentionnés dans le **Parts No.** ne sont pas fournis.Teile ohne **Parts No.** werden nicht geliefert.

15

Ref. No	Add-ress	New Parts	Parts No.	Description	Desti-nation	Re-marks
R372			RK73FB2A162J	CHIP R 1.6K J 1/10W		
R373-377			RK73FB2A102J	CHIP R 1.0K J 1/10W		
R384			RK73FB2A103J	CHIP R 10K J 1/10W		
R385			RK73FB2A513J	CHIP R 51K J 1/10W		
R386			RK73FB2A103J	CHIP R 10K J 1/10W		
R387			RK73EB2B472J	CHIP R 4.7K J 1/8W		
R388			RK73FB2A103J	CHIP R 10K J 1/10W	ET1Q1	
R522			RD14NB2E1R0J	RD 1 J 1/4W		
R534			RK73FB2A101J	CHIP R 100 J 1/10W		
R536			RK73FB2A101J	CHIP R 100 J 1/10W		
R539			RK73FB2A101J	CHIP R 100 J 1/10W		
R542			RK73EB2B101J	CHIP R 100 J 1/8W		
R549			RK73FB2A102J	CHIP R 1.0K J 1/10W		
R555, 556			RK73FB2A103J	CHIP R 10K J 1/10W		
R562			RK73FB2A102J	CHIP R 1.0K J 1/10W		
R578			RK73FB2A103J	CHIP R 10K J 1/10W		
R587			RK73FB2A103J	CHIP R 10K J 1/10W		
R590			RK73FB2A222J	CHIP R 2.2K J 1/10W		
R592			RK73FB2A102J	CHIP R 1.0K J 1/10W		
R598			RK73FB2A361J	CHIP R 360 J 1/10W	X1	
R599			RK73FB2A472J	CHIP R 4.7K J 1/10W	X1	
W503			R92-0670-05	CHIP R 0 OHM		
W504			R92-0679-05	CHIP R 0 OHM		
W505			R92-0670-05	CHIP R 0 OHM	X1	
W506, 507			R92-0670-05	CHIP R 0 OHM	ET1Q1	
W507			R92-0670-05	CHIP R 0 OHM	X1	
W508			R92-0679-05	CHIP R 0 OHM	X1	
W509			R92-0670-05	CHIP R 0 OHM	X1	
K1-4			S76-0076-05	MAGNETIC RELAY		
S501-507			S70-0031-05	TACT SWITCH		
S509-512			S70-0031-05	TACT SWITCH		
S514-516			S70-0031-05	TACT SWITCH		
S520, 521			S70-0031-05	TACT SWITCH		
S517			T99-0602-05	ROTARY ENCODER		
S518, 519			T99-0605-05	ROTARY ENCODER		
D1			D4SBL20UF03	DIODE		
D2			D4SBL20UF03	DIODE	X1	
D2			D5SBA20F03	DIODE	ET1Q1	
D3-6			S5688B	DIODE		
D3-6			1SR139-400	DIODE		
D8, 9			HZS16N(B2)	ZENER DIODE		
D8, 9			MTZJ16(B)	ZENER DIODE		
D11			HZS7.5N(B2)	ZENER DIODE		
D11			MTZJ7.5(B)	ZENER DIODE		
D12-14			HZS8.2N(B2)	ZENER DIODE		
D12-14			MTZJ8.2(B)	ZENER DIODE		
D15, 16			HZS6.8N(B2)	ZENER DIODE		
D15, 16			MTZJ6.8(B)	ZENER DIODE		
D17			HSS104A	DIODE		
D17			1SS133	DIODE		
D18			HZS4.7N(B2)	ZENER DIODE		
D18			MTZJ4.7(B)	ZENER DIODE		
D19			HZS3.3N(B2)	ZENER DIODE		
D19			MTZJ3.3(B)	ZENER DIODE		

L : Scandinavia

K : USA

P : Canada

R : Mexico

C : China

I : Malaysia

Y : PX(Far East, Hawaii)

T : Europe

E : Europe

G : Germany

V : China(Shanghai)

Y : AAFES(Europe)

X : Australia

Q : Russia

H : Korea

M : Other Areas

△ indicates safety critical components.

* New Parts

Parts without **Parts No.** are not supplied.Les articles non mentionnés dans le **Parts No.** ne sont pas fournis.Teile ohne **Parts No.** werden nicht geliefert.

16

Ref. No	Add-ress	New Parts	Parts No.	Description	Desti-nation	Re-marks
D20-23			MA111	DIODE		
D24, 25			HZS18N(B2)	ZENER DIODE		
D24, 25			MTZJ18(B)	ZENER DIODE		
D26, 27			MA111	DIODE	ET1Q1	
D28			MA111	DIODE	X1	
D29			MA111	DIODE	ET1Q1	
D30			MA111	DIODE	X1	
D31			HZS24N(B2)	ZENER DIODE	ET1Q1	
D31			HZS30N(B2)	ZENER DIODE	X1	
D31			MTZJ24(B)	ZENER DIODE	ET1Q1	
D31			MTZJ30(B)	ZENER DIODE	X1	
D33			MA111	DIODE		
D34, 35		*	UDZ10B	ZENER DIODE	ET1Q1	
D34, 35			UDZ15B	ZENER DIODE	X1	
D503			HSS104A	DIODE		
D503			1SS133	DIODE		
D504			HSS104A	DIODE	Q1	
D504			1SS133	DIODE	Q1	
D505			HSS104A	DIODE	ET1X1	
D505			1SS133	DIODE	ET1X1	
D507			HSS104A	DIODE	Q1	
D507			1SS133	DIODE	Q1	
D508-522			HSS104A	DIODE		
D508-522			1SS133	DIODE		
D524			HSS104A	DIODE		
D524			1SS133	DIODE		
D525			HZS6.2N(B2)	ZENER DIODE		
D525			MTZJ6.2(B)	ZENER DIODE		
D526			HSS104A	DIODE		
D526			1SS133	DIODE		
D529			HSS104A	DIODE		
D529			1SS133	DIODE		
D531			HSS104A	DIODE		
D531			1SS133	DIODE	X1	
ED51		2B	11-MT-116GK	INDICATOR TUBE		
△ IC1			TA7815SB	ANALOGUE IC		
△ IC2			TA79015SB	ANALOGUE IC		
△ IC3			STK411-230D	HYBRID IC		
△ IC4			STK410-030D	HYBRID IC		
△ IC5			NJM4580ED	ANALOGUE IC		
IC6			TC9164AF	MOS-IC		
IC7			TC9163AF	MOS-IC		
IC8			NJM4565MD	IC(OP AMP X2)		
IC9			M62446FP	ANALOGUE IC		
IC10-12			NJM4565MD	IC(OP AMP X2)		
IC51			CXP82852-134Q	MI-COM IC		
IC52			X24C02S	MEMORY IC		
IC53			S-80740AL-A4	IC(VOLTAGE DETECTOR)		
IC54			SAA6579T/R	ANALOGUE IC		
Q1			2SC1845(F,E)	TRANSISTOR		
△ Q2			2SB1640	TRANSISTOR		
△ Q3-14			2SC2878(B)	TRANSISTOR		
△ Q15, 16			2SA1576A(R,S)	TRANSISTOR		
Q17-21			2SC1845(F,E)	TRANSISTOR		
Q23			2SA992(F,E)	TRANSISTOR		

L : Scandinavia

K : USA

P : Canada

R : Mexico

C : China

I : Malaysia

Y : PX(Far East, Hawaii)

T : Europe

E : Europe

G : Germany

V : China(Shanghai)

Y : AAFES(Europe)

X : Australia

Q : Russia

H : Korea

M : Other Areas

△ indicates safety critical components.

PARTS LIST

KRF-V8010D/V8010DW

* New Parts

Parts without **Parts No.** are not supplied.

Les articles non mentionnés dans le **Parts No.** ne sont pas fournis.

Teile ohne **Parts No.** werden nicht geliefert.

17

Ref. No	Add-ress	New Parts	Parts No.	Description	Desti-nation	Re-marks
Q24, 25			2SC1845(F,E)	TRANSISTOR		
Q26-29			DTC123JUA	DIGITAL TRANSISTOR		
Q31			2SC2631(S,T)	TRANSISTOR		
Q31			2SC3245A(F)	TRANSISTOR		
Q32			2SA1123(S,T)	TRANSISTOR		
Q32			2SA1285A(F)	TRANSISTOR		
Q34, 35			2SC1845(F,E)	TRANSISTOR		
Q36			2SA1535(Q,R)	TRANSISTOR		
Q37			2SC1845(F,E)	TRANSISTOR		
Q38			2SC3722K(R,S)	TRANSISTOR		
Q39			DTC113ZUA	DIGITAL TRANSISTOR	X1	
Q40			2SC4213(B)	TRANSISTOR	X1	
Q41			2SC4081(R,S)	TRANSISTOR		
Q41			2SD1819A(Q,R)	TRANSISTOR		
Q42			2SC3722K(R,S)	TRANSISTOR	ET1Q1	
Q501			2SC4081(R,S)	TRANSISTOR		
Q501			2SD1819A(Q,R)	TRANSISTOR		
Q503			2SC4081(R,S)	TRANSISTOR		
Q503			2SD1819A(Q,R)	TRANSISTOR		
Q504			2SC4081(R,S)	TRANSISTOR	X1	
Q504			2SD1819A(Q,R)	TRANSISTOR	X1	
TH1		*	PTH9C42BD471Q	POSITIVE RESISTOR	X1	
A501	2B		W02-2625-05	OPTIC RECEIVING MODULE		

HOW TO READ THE PARTS LIST

ABBREVIATION OF MODEL AND MASS PRODUCTION'S DESTINATIONS

MODEL	ABB.	Australia	Canada	China	England	Europe	Germany	Korea	Malaysia
KRF-V8010D	-	X1	-	-	T1	E	-	-	-
KRF-V8010DW	-	-	-	-	-	-	-	-	-
MODEL	ABB.	Mexico	PX/AAFES	Russia	Scandinavia	Shanghai	USA	Other area	
KRF-V8010D	-	-	-	-	-	-	-	-	
KRF-V8010DW	-	-	-	Q1	-	-	-	-	

PARTS LIST

KRF-V8010D/V8010DW

L : Scandinavia K : USA P : Canada R : Mexico C : China I : Malaysia
 Y : PX(Far East, Hawaii) T : Europe E : Europe G : Germany V : China(Shanghai)
 Y : AAFES(Europe) X : Australia Q : Russia H : Korea M : Other Areas Δ indicates safety critical components.

KRF-V8010D/V8010DW

SPECIFICATIONS

For U.K., Europe and Russia

AUDIO section

Rated power output during STEREO operation

(DIN) 1 kHz, 0.7% at 4 Ω 100 W + 100 W
(IEC) 63 Hz~12.5 kHz, 0.7% at 4 Ω 100 W + 100 W
(Except for Russia)

Effective power output during SURROUND operation

FRONT (1kHz, 0.7% T.H.D. at 4 Ω one channel driven)
..... 100 W + 100 W
CENTER (1kHz, 0.7% T.H.D. at 4 Ω one channel driven)
..... 100 W
SURROUND (1kHz, 0.7% T.H.D. at 4 Ω one channel driven)
..... 100 W + 100 W

Total harmonic distortion 0.03% (1 kHz, 50W, 4 Ω)

Signal to noise ratio

PHONO (MM) 75 dB (IHF'66)
54 dB (DIN 50mW output)(Except for Russia)
CD 91 dB (IHF'66)
55 dB (DIN 50mW output)(Except for Russia)

Input sensitivity / impedance

PHONO (MM) 2.5 mV / 27 k Ω
CD 200 mV / 47 k Ω
DVD 6CH (SUBWOOFER) 200 mV / 10 k Ω

Output level / impedance

TAPE REC 200 mV / 1 k Ω
PRE OUT (CENTER, SURROUND) 1 V / 1 k Ω
PRE OUT (SUBWOOFER) 1 V / 600 Ω

Tone control

BASS ± 10 dB (at 100 Hz)
TREBLE ± 10 dB (at 10 kHz)

VIDEO section

VIDEO inputs / outputs

VIDEO (composite) 1 Vp-p / 75 Ω

FM tuner section

Tuning frequency range

U.K. and Europe 87.5 MHz ~ 108 MHz
Russia 87.5 MHz ~ 108 MHz,
65.0 MHz ~ 74.0 MHz

Usable sensitivity (DIN, 75 Ω)

MONO 1.2 μ V / 13.2 dBf (40 kHz DEV., S/N 26 dB)
STEREO 35 μ V / 42.1 dBf (46 kHz DEV., S/N 46 dB)

Total harmonic distortion (DIN, 1 kHz)

MONO 0.2% (65.2 dBf input)
STEREO 0.8% (65.2 dBf input)

Signal to noise ratio (DIN weighted, 1 kHz)

U.K. and Europe
MONO 65 dB (40 kHz DEV.)
STEREO 60 dB (46 kHz DEV.)
Russia
MONO 63 dB (40 kHz DEV.)
STEREO 58 dB (46 kHz DEV.)

Stereo separation (DIN, 1 kHz) 36 dB

Selectivity (DIN, ± 300 kHz) 64 dB

Frequency response (30 Hz ~ 15kHz) +0.5 dB, -3.0 dB

AM tuner section

Tuning frequency range 531 kHz ~ 1,602 kHz

Usable sensitivity (30% mod., S/N 20 dB)

..... 16 μ V / (600 μ V/m)

Signal to noise ratio (30% mod., 1 mV input) 50 dB

GENERAL

Power consumption 250 W

AC outlet

SWITCHED 2 (total 150 W max.)

Dimensions W : 440 mm

H : 144 mm

D : 400 mm

Weight (Net) 9.3 kg



1. KENWOOD follows a policy of continuous advancements in development. For this reason specifications may be changed without notice.
2. Sufficient performance may not be possible at very low temperatures (0°C or less).

KRF-V8010D/V8010DW

SPECIFICATIONS

For Australia

AUDIO section

Rated power output during STEREO operation

100 watts per channel minimum RMS, both channels driven, at 8 Ω from 40 Hz to 20 kHz with no more than 0.7% total harmonic distortion.(FTC)

Effective power output during SURROUND operation

FRONT (1kHz, 10% T.H.D. at 8 Ω one channel driven)
 100 W + 100 W
 CENTER (1kHz, 10% T.H.D. at 8 Ω one channel driven)
 100 W
 SURROUND (1kHz, 10% T.H.D. at 8 Ω one channel driven)
 100 W + 100 W

Total harmonic distortion 0.03% (1 kHz, 50W, 8 Ω)

Signal to noise ratio

PHONO (MM) 75 dB (IHF'66)
 CD 91 dB (IHF'66)

Input sensitivity / impedance

PHONO (MM) 2.5 mV / 27 k Ω
 CD 200 mV / 47 k Ω
 DVD 6CH (SUBWOOFER) 200 mV / 10 k Ω

Output level / impedance

TAPE REC 200 mV / 1 k Ω
 PRE OUT (CENTER, SURROUND) 1 V / 1 k Ω
 PRE OUT (SUBWOOFER) 1 V / 600 Ω

Tone control

BASS ± 10 dB (at 100 Hz)
 TREBLE ± 10 dB (at 10 kHz)

VIDEO section

VIDEO inputs / outputs

VIDEO (composite) 1 Vp-p / 75 Ω

FM tuner section

Tuning frequency range 87.5 MHz ~ 108 MHz

Usable sensitivity (DIN, 75 Ω)

MONO 1.6 μ V / 15.2 dBf (75 kHz DEV., S/N 30 dB)
 STEREO 31.6 μ V / 41.2 dBf (75 kHz DEV., S/N 30 dB)

Total harmonic distortion (DIN, 1 kHz)

MONO 0.6% (65 dBf input)
 STEREO 0.7% (65 dBf input)

Signal to noise ratio (DIN weighted, 1 kHz)

U.K. and Europe
 MONO 75 dB (75 kHz DEV.)
 STEREO 68 dB (75 kHz DEV.)

Stereo separation (DIN, 1 kHz) 38 dB

Selectivity (DIN, ± 400 kHz) 50 dB

Frequency response (30 Hz ~ 15kHz) +0.5 dB, -3.0 dB

AM tuner section

Tuning frequency range 531 kHz ~ 1,602 kHz

Usable sensitivity (30% mod., S/N 20 dB)

..... 16 μ V / (600 μ V/m)

Signal to noise ratio (30% mod., 1 mV input) 50 dB

GENERAL

Power consumption 250 W

AC outlet

SWITCHED 1 (150 W max.)

Dimensions W : 440 mm

H : 144 mm

D : 400 mm

Weight (Net) 9.7 kg



1. KENWOOD follows a policy of continuous advancements in development. For this reason specifications may be changed without notice.
2. Sufficient performance may not be possible at very low temperatures (0°C or less).

KRF-V8010D/V8010DW

Note:

Component and circuit are subject to modification to insure best operation under differing local conditions. This manual is based on Europe (E) standard, and provides information on regional circuit modification through use of alternate schematic diagrams, and information on regional component variations through use of parts list.

KENWOOD CORPORATION

14-6,Dogenzaka 1-chome, Shibuya-ku, Tokyo, 150-8501 Japan

KENWOOD SERVICE CORPORATION

P.O BOX 22745, 2201 East Dominguez St., Long Beach, CA 90801-5745, U.S.A.

KENWOOD ELECTRONICS CANADA INC.

6070 Kestrel Road, Mississauga, Ontario, Canada L5T 1S8

KENWOOD ELECTRONICS LATIN AMERICA S.A.

P.O.BOX 55-2791, Piso 6 plaza Chase, Cl. 47 y Aquilino de la Guardia Panama, Republic de Panama

KENWOOD ELECTRONICS BRASIL LTDA.

Av Indianópolis, 628, 04062-001 Planalto Paullsta São Paulo-SP-Brasil

KENWOOD ELECTRONICS U.K. LIMITED

KENWOOD House, Dwight Road, Watford, Herts., WD1 8EB., United Kingdom

KENWOOD ELECTRONICS BELGUM N.V.

Meachelsesteenweg 418, B-1930 Zaventem, Belgium

KENWOOD ELECTRONICS DEUTSCHLAND GMBH

Rembrücker Str. 15, 63150 Heusenstamm, Germany

KENWOOD ELECTRONICS FRANCE S.A.

13 Boulevard Ney, 75018 Paris, France

KENWOOD ELECTRONICS ITALIA S.p.A.

Via G. Sirtori, 7/9 20129, Milano, Italy

KENWOOD IBÉRICA S.A.

Bolivia, 239-08020 Barcelona, Spain

KENWOOD ELECTRONICS AUSTRALIA PTY. LTD.

(A.C.N. 001499 074)

P.O Box 504, 8 Figtree Drive, Australia Centre, Homebush, N.S.W. 2140, Australia

KENWOOD & LEE ELECTRONICS, LTD.

Unit 3712-3724, Level 37, Tower 1, Metroplaza, 223 Hing Fong Road, Kwai Fong N.T., Hong Kong

KENWOOD ELECTRONICS GULF FZE

P.O.Box 61318, Jebel Ali, Dubai, U.A.E.

KENWOOD ELECTRONICS SINGAPORE PTE LTD.

No. 1 Genting Lane #02-02, KENWOOD Building, Singapore, 349544

KENWOOD ELECTRONICS (MALAYSIA) SDN BHD.

#4.01 Level 4, Wisma Academy Lot 4A, Jalan 19/1 46300 Petaling Jaya Selangor Darul Ehsan Malaysia

KENWOOD ELECTRONICS (THAILAND) CO., LTD.

573/111 Soi Ramkhamhaeng 39, Ramkhamhaeng Road, Wangthonglang, Bangkok, Bangkok 10301 Thailand