

**KRF-V7030D/V7030D-S**  
**KRF-V8030D/V8030D-S**  
**VR-407/409**  
**SERVICE MANUAL**

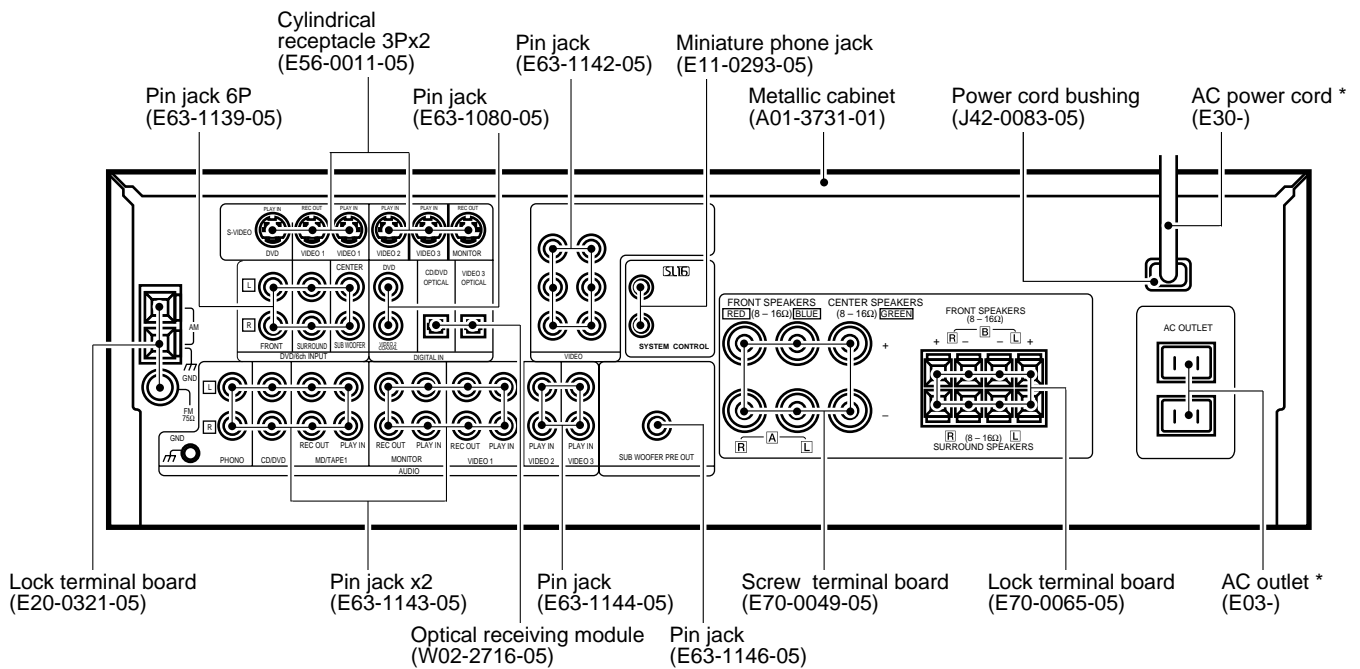
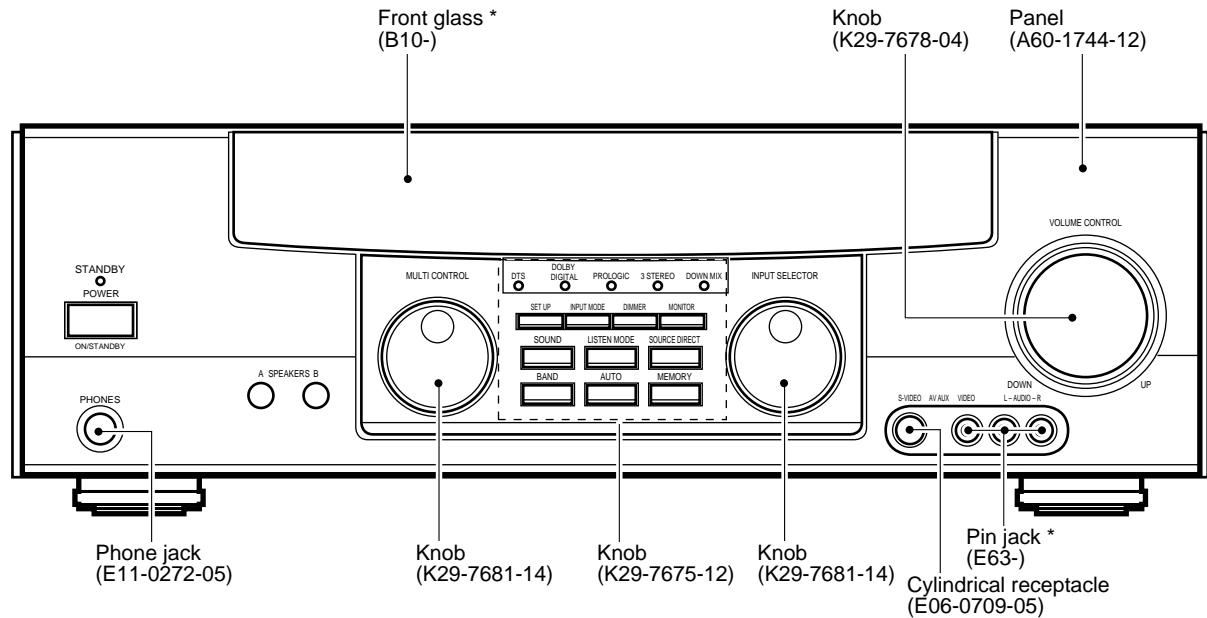

Illustration is KRF-V7030D E type.

\* Refer to parts list on page 39.





# KRF-V7030D/V8030D/VR-407/409

## CONTENTS / ACCESSORIES

### Contents

CONTENTS / ACCESSORIES .....	2	SCHEMATIC DIAGRAM .....	17
BLOCK DIAGRAM .....	3	EXPLODED VIEW .....	37
CIRCUIT DESCRIPTION .....	4	PARTS LIST .....	38
ADJUSTMENT .....	11	SPECIFICATIONS .....	51
PC BOARD .....	12		

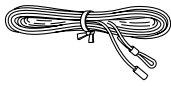
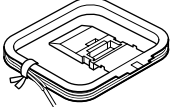
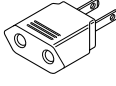
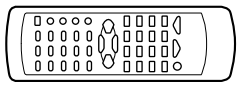
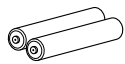
### Accessories

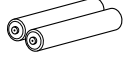
<p>FM indoor antenna (1) (T90-0836-05)</p> 	<p>AM loop antenna (1) (T90-0852-05)</p> 	<p>*AC plug adaptor (1) (E03-0115-05)</p> 	<p>* Use to adapt the plug on the power cord to the shape of the wall outlet. (Accessory only for regions where use is necessary.)</p>
<p>Remote control unit (1) RC-R0609/R0610</p> 	<p>Batteries (R6/AA) (2)</p> 	<p>Remote control unit (1) RC-R0808/0809</p> 	<p>Batteries (R6/AA) (2)</p> 

### Model name vs remote controller

MODEL	Destinations	Remote Controller		
		Parts number	Model name	Battery cover
VR-407	K	A70-1330-05	RC-R0609	A09-1178-08
VR-407	P	A70-1330-05	RC-R0609	A09-1178-08
KRF-V7030D	Y	A70-1330-05	RC-R0609	A09-1178-08
KRF-V7030D-S	M	A70-1330-05	RC-R0609	A09-1178-08
KRF-V7030D-S	I	A70-1330-05	RC-R0609	A09-1178-08
KRF-V7030D-S	X	A70-1330-05	RC-R0609	A09-1178-08
VR-407-S	K1	A70-1330-05	RC-R0609	A09-1178-08
VR-409	K	A70-1315-05	RC-R0809	A09-1166-08
VR-409	P	A70-1315-05	RC-R0809	A09-1166-08
KRF-V8030D	Y	A70-1315-05	RC-R0809	A09-1166-08
KRF-V8030D-S	M	A70-1315-05	RC-R0809	A09-1166-08
KRF-V8030D-S	I	A70-1315-05	RC-R0809	A09-1166-08
KRF-V8030D-S	X	A70-1315-05	RC-R0809	A09-1166-08
KRF-V8030D	E	A70-1345-05	RC-R0808	A09-1166-08
KRF-V7030D	E1	A70-1331-05	RC-R0610	A09-1178-08
KRF-V7030D	T	A70-1331-05	RC-R0610	A09-1178-08

### Cautions

#### Resetting the Microcomputer

If the microcomputer may malfunction (unit cannot be operated, or shows an erroneous display) if the power cord is unplugged while the power is ON, or due to some other external factor. If this happens, execute the following procedure to reset the microcomputer and return the unit to its normal operating condition.

\* Please note that resetting the microcomputer will clear the contents of the memory and returns the unit to the state it was in when it left the factory.

#### For U.S.A. and Canada

Unplug the power cord from the wall outlet, then plug it back in while holding down the POWER key.

#### For other countries

With the power cord plugged in, turn the POWER key OFF. Then, while holding down the ON/STANDBY key, press POWER.





## CIRCUIT DESCRIPTION

## 3-2 Pin description

Pin No.	Pin Name	I/O	Description
1	S. DATA	I/O	Serial data signal.
2	S.BUS	I/O	Serial busy signal.
3	SEL. ST1	O	Strobe output to input selector ( IC106).
4	SEL/VOL/PLL DT	O	Data output to selector,volume and PLL IC.
5	SEL/VOL/PLL CLK	O	Clock output to selector,volume and PLL IC.
6	SEL. ST2	O	Strobe 2 output to input selector ( IC109).
7	PLL. CE	O	PLL chip enable.
8	Vdd (+5v)	-	Power supply.
9	OSC OUT	O	8MHz clock output.
10	OSC IN	I	8MHz clock input.
11	Vss	-	Connected to ground.
12	X IN	-	Connected to ground.
13	X OUT	-	No used.
14	MMCD	-	Connected to ground.
15	Vref-	-	Connected to ground.
16,17	KEY2,KEY1	I	Input terminal of key1 and key2.
18	MODEL TYPE	I	Discrimination port of models.
19	TH. SENS	I	No used.
20	PROTECT	I	Detection port of protection signal 1.
21	PROTECT2	I	Detection port of protection signal 2.
22	S.LEVEL/CH SPACE	I	RDS S level and channel space changeover.
23	PLL DO	I	RDS PLL data signal input.
24	Vref+	-	Reference voltage of AD converter..
25	CE	I	Chip enable.
26	RESET	I	Reset signal input.
27	T. MUTE	O	Muting signal output to tuner.
28	RF ST	O	CE signal output of RF receiver IC.
29	RF DT	O	Data signal output of RF receiver IC.
30	RF CLK	O	Clock signal output of RF receiver IC.
31	VOL.ST	O	Latch output of electric volume.
32	DSP INTREQ	I/O	Detection port of DSP INTREQ.
33	DTS DET	I	Detection port of DTS data.
34	REMOCON	I	Remote control signal input.
35	DIR ERR	I	Detection port of DIR error signal.
36	DZF	I	Detection port of CODEC zero input.
37	RDS.CLK	I	RDS clock input.
38	RDS.DAT/CE2	I	RDS data input./u-COM chip enable 2.
39	DSP/DIR/CORDEC CDIN	O	Serial data output.
40	DSP/DIR/CDOUT	I	Serial data input.
41	DSP/DIR/CORDEC CCLK	O	Clock output to IC2, IC5 and IC51on X08.
42	DSP CS	O	DSP chip select.
43	DSP PD	O	DSP power down.
44	DIR CODEC CS	O	CODEC chip select.
45	DIR CODEC PD	O	DIR CODEC power down.
46	NO USE	-	No used.
47-57	1G-11G	O	FL grid control(1G-11G).
58-74	P1-P17	O	FL segment control(P1-P17).
75	PACK CONT.	O	Power pack control.
76	LIMMITER	O	Control port of A class power supply.
77	REAR RE	O	Relay control terminal of surround speaker.
78	CENTER RE	O	Relay control terminal of center speaker.
79	FB RE	O	Relay control terminal of front B speaker.
80	FA RE	O	Relay control terminal of front A speaker.

# KRF-V7030D/V8030D/VR-407/409

## CIRCUIT DESCRIPTION

Pin No.	Pin Name	I/O	Description
81	POWER RE	O	Power relay control.
82	CS5. 1(DOWN MIX)LED	O	Control terminal of CS5.1(DOWN MIX) LED.
83	3 STEREO LED	O	Control terminal of 3 STEREO LED.
84	DTS LED	O	Control terminal of DTS LED.
85	DOLBY DIGITAL LED	O	Control terminal of DOLBY DIGITAL LED.
86	PROLOGIC LED	O	Control terminal of PROLOGIC LED.
87	STANDBY LED	O	Control terminal of STANDBY LED.
88	PRE OUT MUTE	O	Muting control terminal of pre out.
89	20dB ATT	O	20dB attenuation(volume) control terminal.
90	A.MUTE	O	Audio muting signal output.
91	ABOOT	O	EPROM CS.
92	MULTI. ENC CW	I	Multi cont. encoder signal input(clockwise).
93	MULTI. ENC CCW	I	Multi cont. encoder signal input(counterclockwise).
94	SEL. ENC CW	I	Selector encoder signal input(clockwise).
95	SEL. ENC CCW	I	Selector encoder signal input(counterclockwise).
96	VOL. ENC CW	I	Volume encoder signal input(clockwise).
97	VOL. ENC CCW	I	Volume encoder signal input(counterclockwise).
98	STEREO	I	Stereo (tuner) signal input.
99	SD	I	Tuner (SD)detector input.
100	Vpp(-30V)	-	FL power supply(-35V).

### 3-3 SW VS VOLTAGE

IC1(X14) MICROPROCESSOR:MN101C35DRA

VOLTAGE	AD VALUE	KEY1(#16)	KEY2(#17)
5.0V	255		
		ON/STANDBY	KEY OFF
4.5V	230		
		DIMMER	MEMORY
4.0V	205		
		INPUT MODE	AUTO
3.4V	174		
		SETUP	BAND
2.8V	143		
		MONITOR	SOUND
2.1V	108		
		SP.B(MUTE)	LISTEN MODE
1.4V	72		
		SP.A(SP ON/OFF)	SOURCE DIRECT
0.8V	41		
		KEY OFF	KEY OFF
0.0V	0		

# KRF-V7030D/V8030D/VR-407/409

## CIRCUIT DESCRIPTION

### 3-4 Switch control table

#### 3-4-1 IC106(X07) INPUT/REC OUT SELECTOR: NJU7313AM

SW#	L-ch pin#	R-ch pin#	Function	INPUT SELECTOR								MODE		TAPE MON		ATT.		
				TUNER	PHONO	CD	TAPE/MD	VIDEO1	VIDEO2	VIDEO3	FRONT AUX	ANALOG	DIGITAL	ON	OFF	ATT1 (-6dB)	ATT2 (-3dB)	OFF
S1	27	2	TUNER	1	0	0	0	0	0	0	0							
S2	26	3	PHONO	0	1	0	0	0	0	0	0							
S3	25	4	CD	0	0	1	0	0	0	0	0							
S4	24	5	TAPE/MD	0	0	0	1	0	0	0	0							
S5	22	7	TAPE/MD REC OUT	1	1	1	0	1	1	1	1							
S6	21	8	VIDEO1 REC OUT	1	1	1	1	0	1	1	1							
S7	19	10	ANALOG									1	0					
S8	18	11	DIGITAL									0	1					

#### IC109(X07) INPUT/ATT. SELECTOR: NJU7313AM

S1	27	2	VIDEO1	0	0	0	0	1	0	0	0							
S2	26	3	VIDEO2	0	0	0	0	0	1	0	0							
S3	25	4	VIDEO3	0	0	0	0	0	0	1	0							
S4	24	5	FRONT AUX	0	0	0	0	0	0	0	1							
S5	20	9	LINE											0	1			
S6	21	8	MONITOR											1	0			
S7	19	10	ATT1													1	0	0
S8	18	11	ATT2													0	1	0

### 3-4-2 ANALOG 6CH INPUT SELECTOR

#### IC14(X08) ANALOG 6-CH INPUT SELECTOR: NJU7311AM

PORT	PIN#	FUNCTION	SELECTOR			
			6-CH INPUT	OTHERS	TAPE2	
LS1	3	CENTER	OTHERS	0	1	1
LS2	2		6-CH INPUT	1	0	0
LS3	5	SURROUND L-CH	OTHERS	0	1	1
LS4	6		6-CH INPUT	1	0	0
LS5	9	FRONT L-CH	OTHERS	0	1	1
LS6	8		6-CH INPUT	1	0	0
LS7	11	REC OUT SW L FOR 6-CH INPUT	1	0	1	
RS1	28	SUBWOOFER	OTHERS	0	1	1
RS2	29		6-CH INPUT	1	0	0
RS3	25	SURROUND R-CH	OTHERS	0	1	1
RS4	26		6-CH INPUT	1	0	0
RS5	22	FRONT R-CH	OTHERS	0	1	1
RS6	23		6-CH INPUT	1	0	0
RS7	20	REC OUT SW R FOR 6-CH INPUT	1	0	1	

### 3-4-3 CONFIGURATION SELECTOR

#### IC12(X08) CONFIGURATION SELECTOR: NJU7311AM

SW#	L-ch pin#	R-ch pin#	Function	MODE		OUTPUT		CONFIGURATION	
				SURROUND	STEREO	DSP	ANALOG	SW OFF	SW ON
S1	2	29	SURROUND	1	0				
S2	3	28	STEREO	0	1				
S3	5	26	DIGITAL			1	0		
S4	6	25	ANALOG			0	1		
S5									
S6									
S7		11/20	CONFIG.					1	0

# KRF-V7030D/V8030D/VR-407/409

## CIRCUIT DESCRIPTION

### 3-4-4 DESTINATION

PORT#	PORT NAME	VR-409						VR-407				VR-406				VR-405/VR-414			
		KRF-V8030D						KRF-V7030D				KRF-V6030D				KRF-V5030D			
		K/P	E/T	M/V/I/Y	X	J		K/P	E/T	M/V/I/Y	X	K/P	E/T	M/V/I/Y	X	K/P	E/T	M/V/I/Y	X
67	D25	0	0	0	0	0	1	1	1	1	0	0	0	0	0	0	0	0	0
66	D26	1	1	1	1	1	0	0	0	0	0	0	0	0	0	0	0	0	0
65	D27	0	0	0	0	0	0	0	0	0	1	1	1	1	0	0	0	0	0
64	D28	0	1	1	1	1	0	1	1	1	0	1	1	1	0	1	1	1	1
63	D29	0	0	0	1	1	0	0	0	1	0	0	0	1	0	0	0	0	1
62	D30	0	1	0	0	1	0	1	0	0	0	1	0	0	0	1	0	0	0

### 3-4-5 Listen Mode

Mode	DTS	Dolby Digital	Pro Logic	3 Stereo	DSP	CS	Stereo
DTS	yes						yes
Dolby Digital (no2-ch)		yes					yes
Dolby Digital (2-ch)			yes	yes			yes
Pro Logic			yes	yes			yes
PCM			yes	yes	yes	yes	yes

Note: Auto Mode function is not change after setting listen mode

### 3-4-6 MODEL vs FEATURE

Function	KRF-V3030D	VR-409	VR-407	VR-406 (except K,P)	VR-406(K,P)	VR-405 (except K,P)	VR-405(K,P)
DTS	yes	yes	yes	no	no	no	no
CS	yes	yes	no	no	no	no	no
6ch input	yes	yes	yes	yes	yes	yes	no
Speaker B	yes	yes	yes	yes	yes	mute	mute
Multi Control	Encoder	Encoder	Encoder	Tact	Tact	Tact	Tact
Monitor	yes(on/off)	yes(on/off)	yes(on/off)	VIDEO2/MONI	VIDEO2/MONI	VIDEO2/MONI	VIDEO2/MONI
AV AUX	yes	yes	yes	no	AUX	no	AUX
PHONO	yes	yes	yes	yes	no	yes	no
Remocon	RF	Preset	Preset	Normal	Normal	Normal	Normal
Diode SW	D1	D2	D3	D4	D5	D6	D7



## CIRCUIT DESCRIPTION

### 3-4-7 Speaker Setup

Subwoofer	yes								
Front SP.	Large								
Center SP.	Large			Normal			no		
Surround SP.	Large	Normal	no	-	Normal(yes)	no	-	Normal(yes)	no
Center Mode (Pro Logic)	Wide	Wide	-	-	Normal	-	-	Phantom	-

Subwoofer	yes								
Front SP.	Normal								
Center SP.	-			Normal(yes)			no		
Surround SP.	-	-	-	-	Normal(yes)	no	-	Normal(yes)	no
Center Mode (Pro Logic)	-	-	-	-	Normal	-	-	Phantom	-

Subwoofer	no								
Front SP.	Large								
Center SP.	Large			Normal			no		
Surround SP.	Large	Normal	no	-	Normal(yes)	no	-	Normal(yes)	no
Center Mode (Pro Logic)	Wide	Wide	-	-	Normal	-	-	Phantom	-

### 4. Test mode specification

1. How to set up the test mode.

Test mode	How to set up.
Normal test mode	BAND key+AC-ON

2. How to cancel the test mode.

- TEST MODE is initialized by cutting off the power supply.
- Power off is initialization can't be set up. Power off cancels only the test mode.

3. How to set up the initialization of the set.

An initialization movement is done, and FL indication is erased when AC is turned on with pushing POWER key of set.

4. A key movement during the all LCDs lighting.

#### 4-1 A setup of Rf receiving frequency one touch. (only VR-410)

Operation key	DISPLAY	Function
<b>SOUND</b> key	Normal indication	RF frequency indication is outputted together in the FL indication when the establishment of the RF receiving frequency is made 411.3MHz. (test mode is not cancel it.)
<b>LISTEN MODE</b> key	Normal indication	RF frequency indication is outputted together in the FL indication when the establishment of the RF receiving frequency is made 414.3MHz. (test mode is not cancel it.)
<b>SOURCE DIRECT</b> key	Normal indication	RF frequency indication is outputted together in the FL indication when the establishment of the RF receiving frequency is made 417.3MHz. (test mode is not cancel it.)

## CIRCUIT DESCRIPTION

### 4-2 S LEVEL indication(only E/T TYPE)

Operation key	DISPLAY	Function
MEMORY key Cyclic function	ATT_ON_HEX DATA ↓ The signal level of tuner	RF ATT ON
	ATT_ON_HEX DATA ↓ The signal level of tuner	RF ATT OFF
	Normal indication	Normal function

### 4-3 CHANNEL SPACE SW(50kHz/100kHz) indication(only M/C/Y//V TYPE)

When SPEAKERS A key is pushed, it is checked, and the condition of CHANNEL SPACE SW of the TUNER circuit board is indicated with EON of the FL indication and TI.VOL.

(It is made to indication of CHANNEL SPACE SW at that time at the time of POWER supply on in FL)

Operation key	DISPLAY	Function
SPEAKERS B key Cyclic function	It turns on EON indication.	When CHANNEL SPACE SW is 50kHz, it turns on EON.
	It turns on TI.VOL indication.	When CHANNEL SPACE SW is 100kHz, it turns on TI.VOL.

### 5. TEST TONE easy function

The key movement when selector is DVD.

Operation key	DISPLAY	FUNCTION
SPEAKERS A key	Normal indication	TEST TONE ON ← → TEST TONE OFF The speaker output of each ch is mode one second.

### 6. A release of TEST MODE

The Key movement when selector is DVD.

Operation key	DISPLAY	FUNCTION
SPEAKERS B key	Normal indication	TEST MODE is canceled. It doesn't need to initialization.

# KRF-V7030D/V8030D/VR-407/409

## ADJUSTMENT

No.	ITEM	INPUT SETTINGS	OUTPUT SETTINGS	RECEIVER SETTINGS	ALIGNMENT POINTS	ALIGN FOR	FIG.
<b>FM SECTION : EXCEPT E,T type      SELECTOR : FM</b>							
1	DISCRIMINATOR (K,P only)	(A) 98.0MHz 1kHz, ±75kHz dev. 70dBf (ANT. input)	Connect a DC voltmeter between CN4 ① and CN4 ② (X07)	98.0MHz	L4 (X07)	0V	
2	TUNING LEVEL	(A) 98.0MHz MONO 1kHz, ±75kHz dev. 29.2dBf (ANT. input)	(B)	MONO 98.0MHz	VR1 (X07)	Adjust VR1 and stop at the point where ED1 (TUNED) goes on.	
<b>FM SECTION : E,T type only      SELECTOR : FM      ※ Adjust NO.1 and NO.2 repeat.</b>							
1	DISCRIMINATOR	(A) 98.0MHz 1kHz, ±40kHz dev. 70dBf (ANT. input)	Connect a DC voltmeter between CN4 ① and CN4 ② (X07)	MONO 98.0MHz	L4 (X07)	0V	
2	DISTORTION (MONO)	(A) 98.0MHz 1kHz, ±40kHz dev. MONO 70dBf (ANT. input)	(B)	MONO 98.0MHz	L5 (X07)	Minimum distortion	
3	DISTORTION (STEREO)	(C) 98.0MHz 1kHz, ±40kHz dev. Selector : L or R Pilot : ±6kHz dev. 70dBf (ANT. input)	(B)	AUTO 98.0MHz	IFT (FRONT END : A1)	Minimum distortion (L or R)	
4	TUNING LEVEL	(A) 98.0MHz MONO 1kHz, ±40kHz dev. 29.2dBf (ANT. input)	(B)	MONO 98.0MHz	VR1 (X07)	Adjust VR1 and stop at the point where ED1 (TUNED) goes on.	

## SYSTEM CONNECTIONS

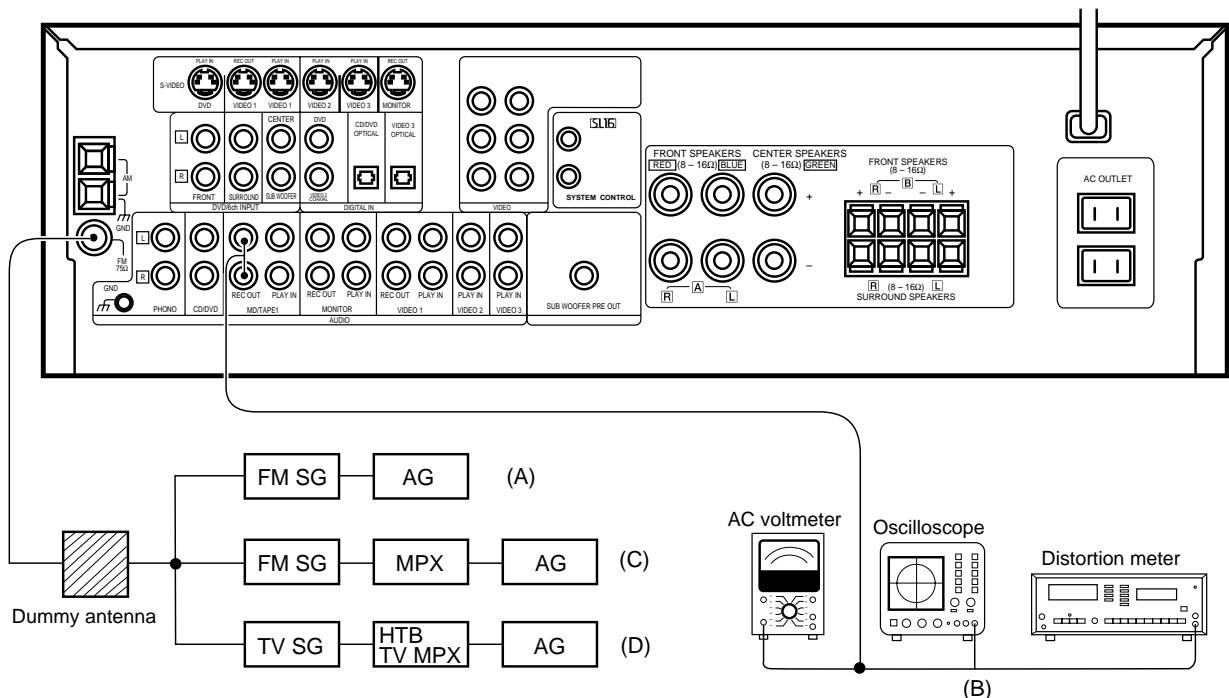

# PC BOARD (Component side view)

X07-3120-10 C/3 (J70-1362-11)  
 X07-3130-10 C/3 (J70-1412-11)

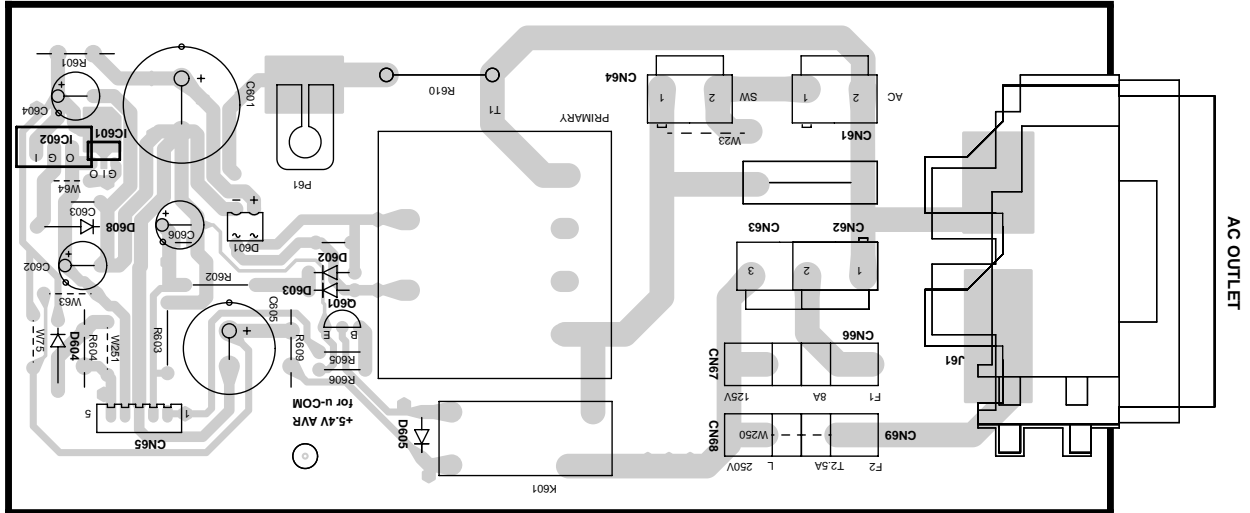

X07 B/3

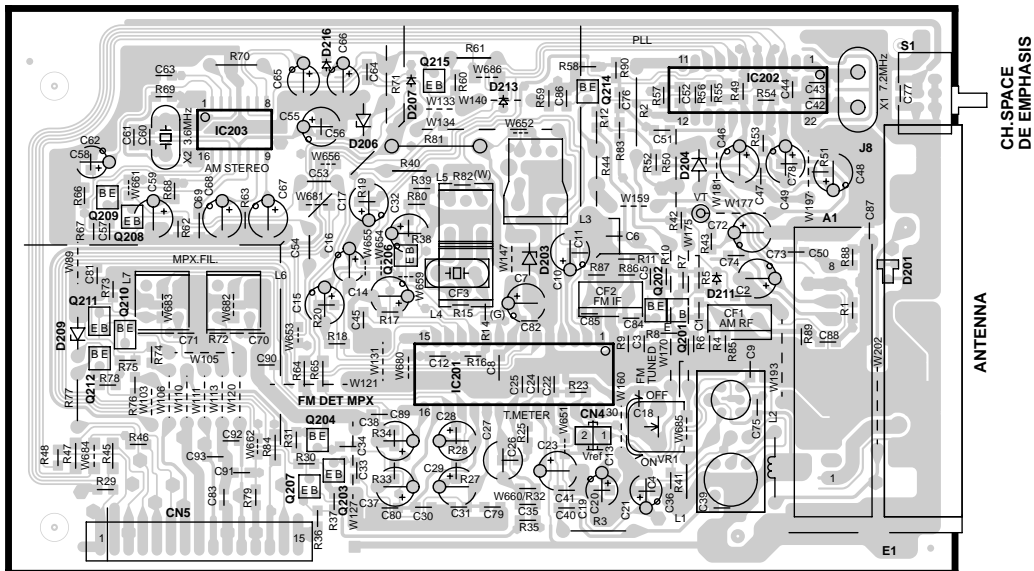

# PC BOARD(Component side view)

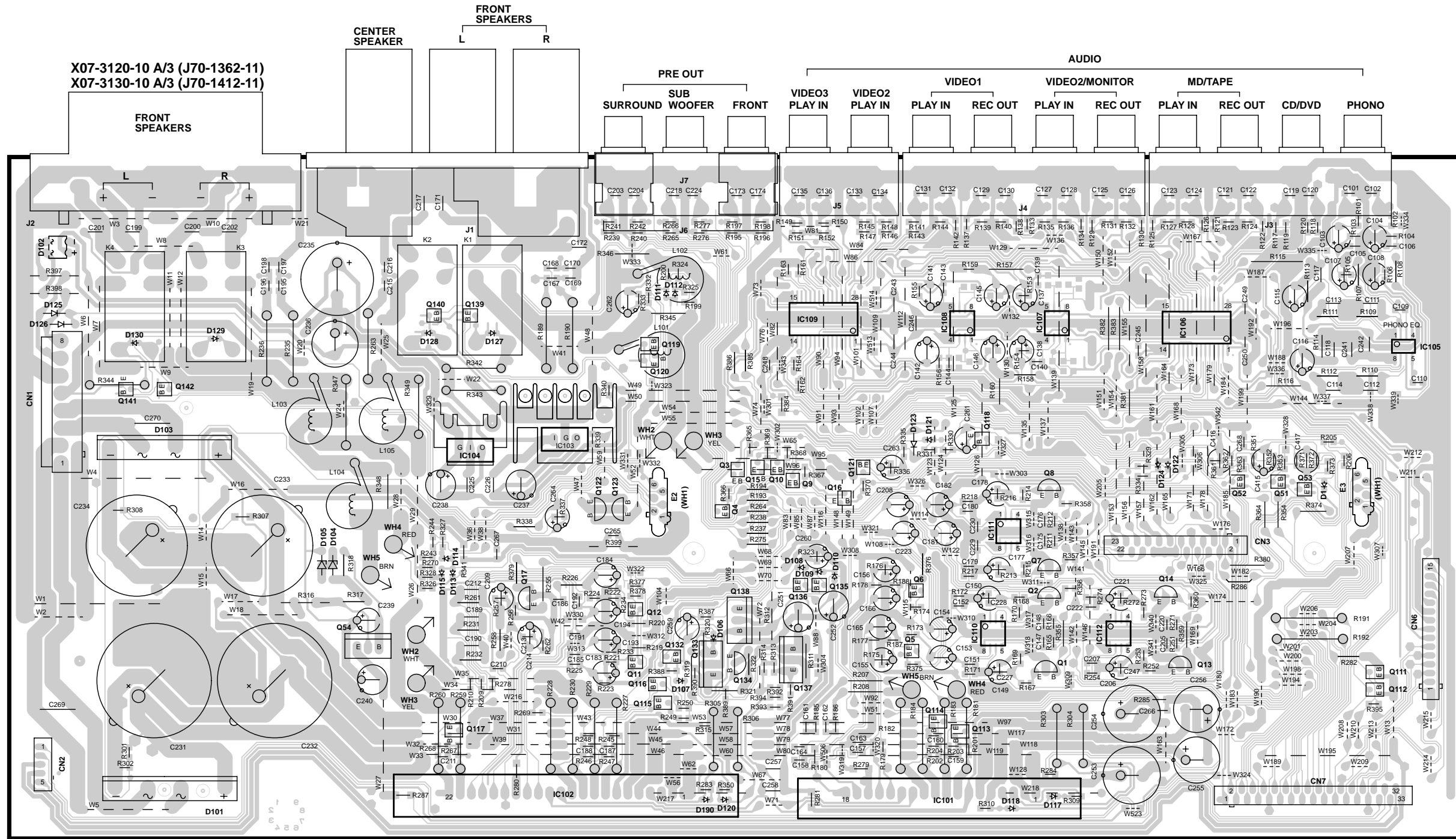

X14 F/6

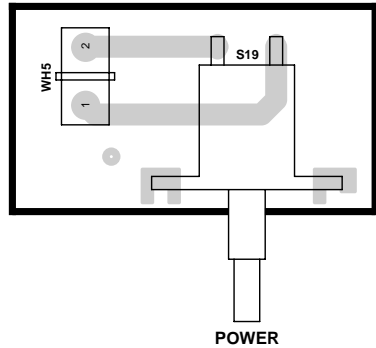

X00-3000-20 (J70-1368-01)

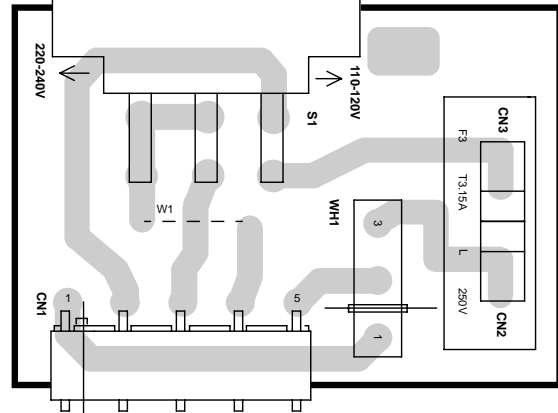



TUNER UNIT (X07-31XX-XX) (B/3)

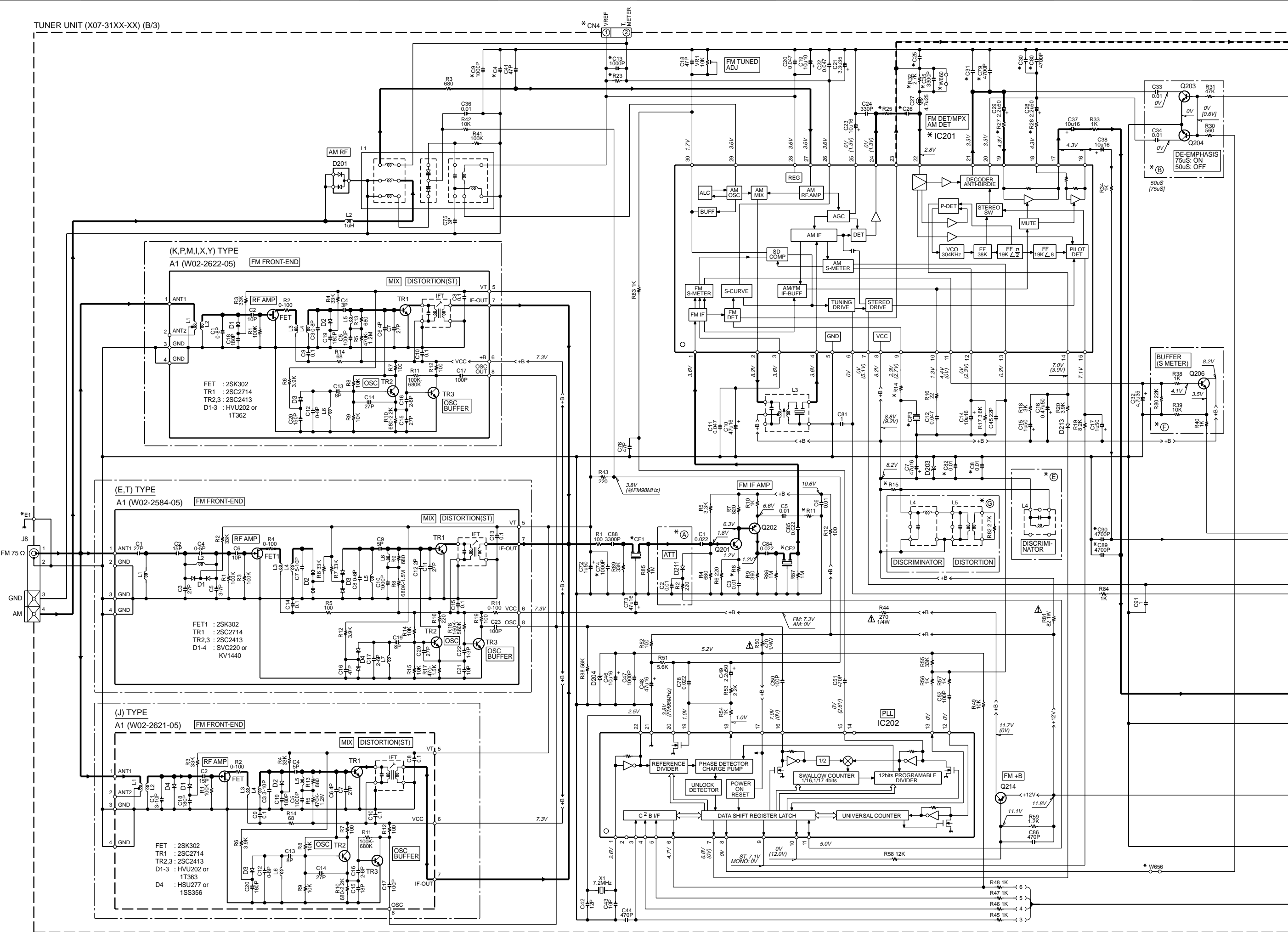

(K,P,M,I,X,Y) TYPE  
A1 (W02-2622-05) FM FRONT-END

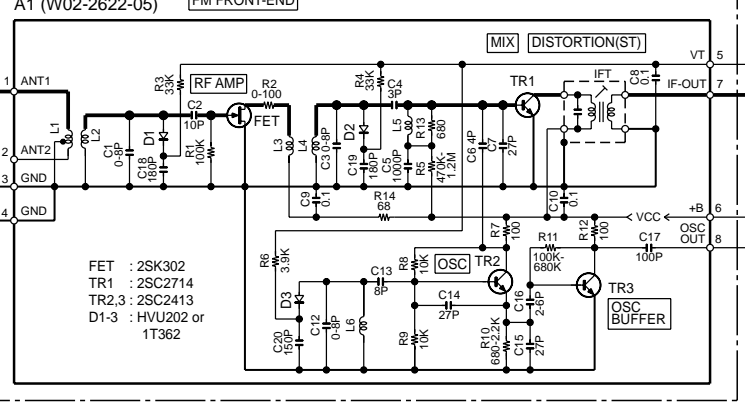

(E,T) TYPE  
A1 (W02-2584-05) FM FRONT-END

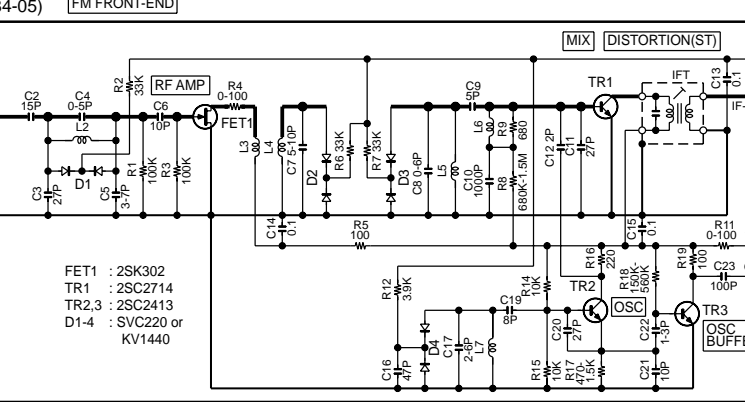

(J) TYPE  
A1 (W02-2621-05) FM FRONT-END

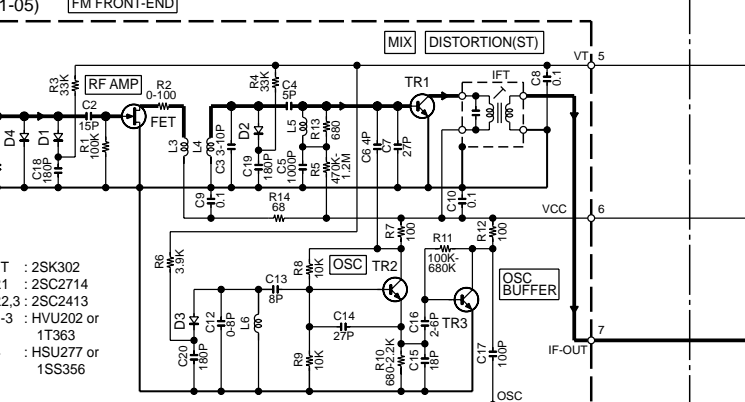

FM IF AMP

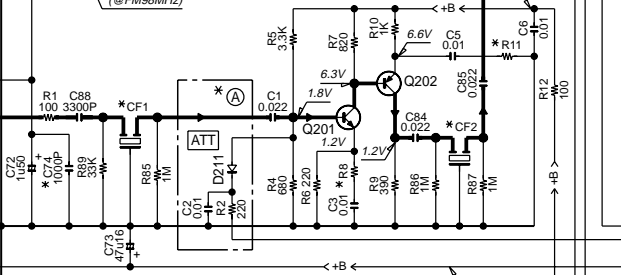

PLL IC202

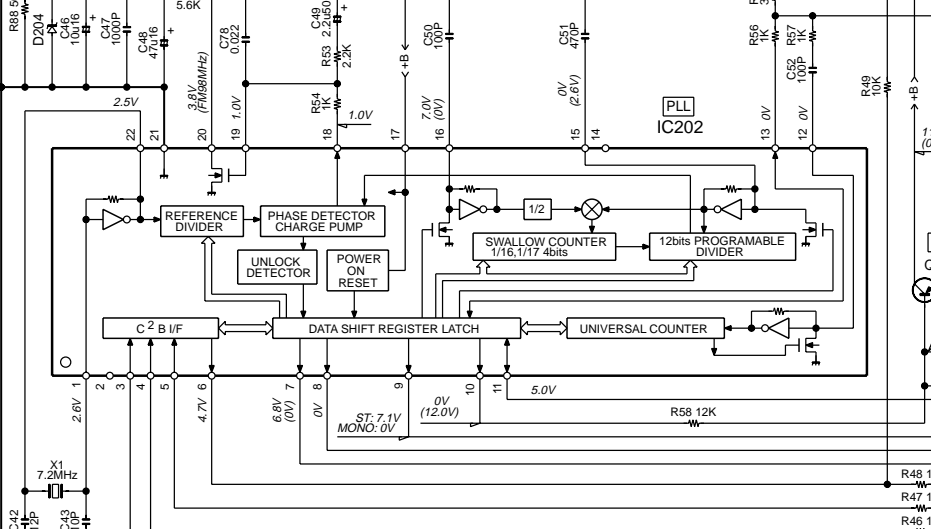

DISCRIMINATOR

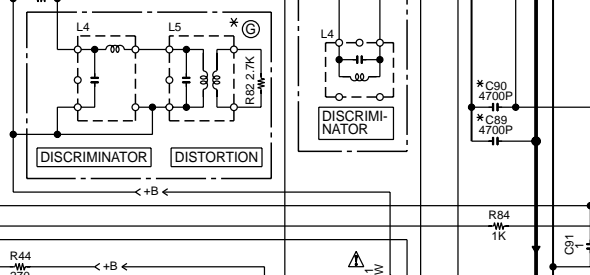

FM DET/MPX AM DET

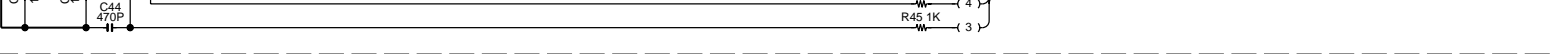
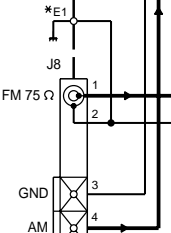
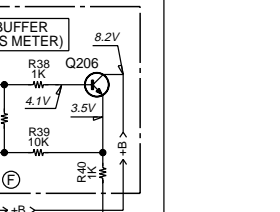
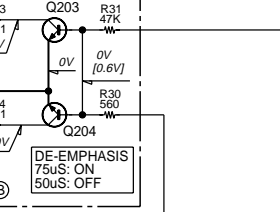
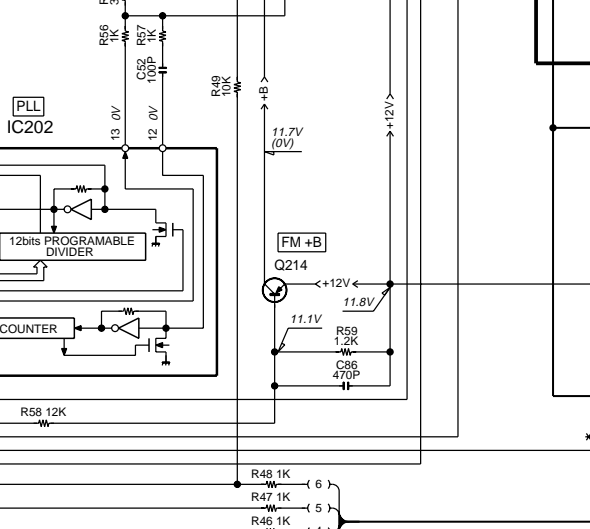



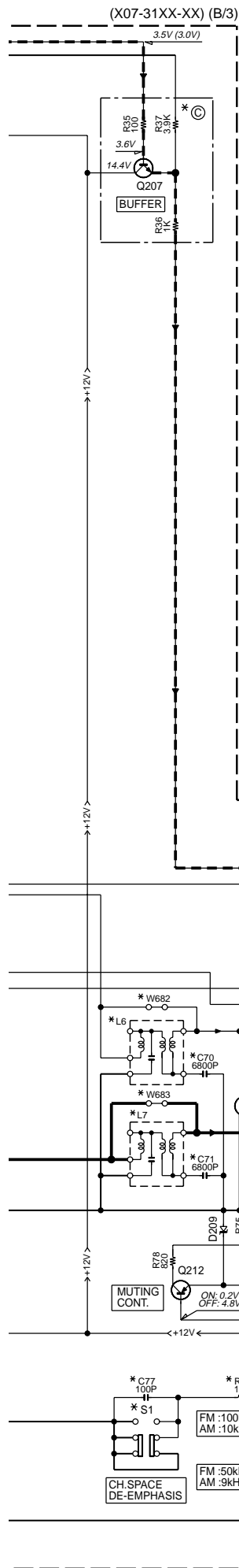

VR-407 (X07-3130-10)

DESTINATION	UNIT No.	A	B	C	F	G	E	R8, 11	R14	R15	R23	R25	R27, 28	R29	R32	R72, 73	C4	C8,9,13,70, 71,77,79,80	C25	C26	C30, 31	C35,74, 82,89,90	CF1,2	CF3	IC201	L6,7	CN4	W656, 660	W682, 683	S1	E1
U.S.A.	K	0-10					YES	33	100	4.7K	9.1K	16K	6.8K	NO	YES	15K	330P	NO	470P	0.022	0.033	YES	L72-0596 (MS2)	NO	LA1837	NO	YES	NO	YES	NO	F10-1129
CANADA	P																														

VR-407-S (X07-3130-10)

DESTINATION	UNIT No.	A	B	C	F	G	E	R8, 11	R14	R15	R23	R25	R27, 28	R29	R32	R72, 73	C4	C8,9,13,70, 71,77,79,80	C25	C26	C30, 31	C35,74, 82,89,90	CF1,2	CF3	IC201	L6,7	CN4	W656, 660	W682, 683	S1	E1
U.S.A.	K1	0-10					YES	33	100	4.7K	9.1K	16K	6.8K	NO	YES	15K	330P	NO	470P	0.022	0.033	YES	L72-0596 (MS2)	NO	LA1837	NO	YES	NO	YES	NO	F10-1129

VR-409 (X07-3120-11)

DESTINATION	UNIT No.	A	B	C	F	G	E	R8, 11	R14	R15	R23	R25	R27, 28	R29	R32	R72, 73	C4	C8,9,13,70, 71,77,79,80	C25	C26	C30, 31	C35,74, 82,89,90	CF1,2	CF3	IC201	L6,7	CN4	W656, 660	W682, 683	S1	E1
U.S.A.	K	0-11					YES	33	100	4.7K	9.1K	16K	6.8K	NO	YES	15K	330P	NO	470P	0.022	0.033	YES	L72-0596 (MS2)	NO	LA1837	NO	YES	NO	YES	NO	F10-1129
CANADA	P																														

KRF-V7030D-S (X07-313X-XX)

DESTINATION	UNIT No.	A	C	E	F	G	B	E	R8, 11	R14	R15	R23	R25	R27, 28	R29	R32	R72, 73	C4,70,71, 79,80,82	C8,9,35, 89,90	C13, 74	C25	C26	C30, 31	C77	CF1,2	CF3	IC201	L6,7	CN4	E656	W660	W682, 683	S1	E1	
GENERAL MARKET	M	0-21					YES	33	270	NO	3.3K	18K	7.5K	YES	YES	8.2K	NO	YES	NO	YES	NO	470P	0.022	0.022	NO	L72-0531 (MA5)	YES	LA1838	NO	NO	YES	NO	YES	YES	F10-1129
MALAYSIA	I						NO	33	270	NO	3.3K	18K	7.5K	NO	YES	8.2K	NO	YES	NO	YES	NO	470P	0.022	0.022	YES	L72-0531 (MA5)	YES	LA1838	NO	NO	YES	NO	YES	NO	F10-1129
AUSTRALIA	X	0-71					NO	33	270	NO	3.3K	18K	7.5K	NO	YES	8.2K	NO	YES	NO	YES	NO	470P	0.022	0.022	NO	L72-0531 (MA5)	YES	LA1838	NO	NO	YES	NO	YES	NO	F10-1129

KRF-V8030D (X07-312X-XX)

DESTINATION	UNIT No.	A	C	F	G	B	E	R8, 11	R14	R15	R23	R25	R27, 28	R29	R32	R72, 73	C4,70,71, 79,80,82	C8,9,35, 89,90	C13, 74	C25	C26	C30, 31	C70,71, 79,80,82	CF1,2	CF3	IC201	L6,7	CN4	W656,682, 683	W660	W682, 683	S1	E1		
PX	Y	2-91					YES	33	33	270	NO	3.3K	18K	7.5K	YES	8.2K	NO	YES	NO	YES	NO	470P	0.022	0.022	NO	L72-0531 (MA5)	YES	LA1838	NO	NO	YES	NO	YES	YES	F10-1129
EUROPE	E	2-71					NO	10	22	100	33K	15K	27K	4.3K	NO	3.9K	YES	NO	YES	NO	180P	0.018	0.022	YES	L72-0536 (MS3)	NO	LA1837	YES	YES	NO	YES	NO	YES	NO	F10-1167

KRF-V7030D (X07-313X-XX)

DESTINATION	UNIT No.	A	C	F	G	B	E	R8, 11	R14	R15	R23	R25	R27, 28	R29	R32	R72, 73	C4,70,71, 79,80,82	C8,9,35, 89,90	C13, 74	C25	C26	C30, 31	C77	CF1,2	CF3	IC201	L6,7	CN4	W656,682, 683	W660	W682, 683	S1	E1		
EUROPE	E1	2-71					NO	10	22	100	33K	15K	27K	4.3K	NO	3.9K	YES	NO	YES	NO	180P	0.018	0.022	NO	L72-0536 (MS3)	NO	LA1837	YES	YES	NO	YES	NO	YES	NO	F10-1167
U.K.	T	0-51					NO	10	22	100	33K	15K	27K	4.3K	NO	3.9K	YES	NO	YES	NO	180P	0.018	0.022	NO	L72-0536 (MS3)	NO	LA1837	YES	YES	NO	YES	NO	YES	NO	F10-1167
PX	Y	2-91					NO	33	33	270	NO	3.3K	18K	7.5K	YES	8.2K	NO	YES	NO	YES	NO	470P	0.022	0.022	NO	L72-0531 (MA5)	YES	LA1838	NO	NO	YES	NO	YES	NO	F10-1129

KRF-V8030D-S (X07-312X-XX)

DESTINATION	UNIT No.	A	C	F	G	B	E	R8, 11	R14	R15	R23	R25	R27, 28	R29	R32	R72, 73	C4,70,71, 79,80,82	C8,9,35, 89,90	C13, 74	C25	C26	C30, 31	C77	CF1,2	CF3	IC201	L6,7	CN4	W656	W660	W682, 683	S1	E1		
GENERAL MARKET	M	0-21					YES	33	270	NO	3.3K	18K	7.5K	YES	YES	8.2K	NO	YES	NO	YES	NO	470P	0.022	0.022	YES	L72-0531 (MA5)	YES	LA1838	NO	NO	YES	NO	YES	YES	F10-1129
MALAYSIA	I						NO	33	270	NO	3.3K	18K	7.5K	NO	YES	8.2K	NO	YES	NO	YES	NO	470P	0.022	0.022	NO	L72-0531 (MA5)	YES	LA1838	NO	NO	YES	NO	YES	NO	F10-1129
AUSTRALIA	X	0-71					NO	33	270	NO	3.3K	18K	7.5K	NO	YES	8.2K	NO	YES	NO	YES	NO	470P	0.022	0.022	NO	L72-0531 (MA5)	YES	LA1838	NO	NO	YES	NO	YES	NO	F10-1129

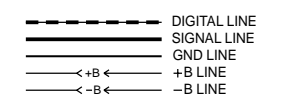

- IC201 : \*
- IC202 : LC72131
- Q201,203,204,206,207 : 2SD1819A(Q,R) or 2SC4081(R,S)
- Q202,212,214 : 2SB1218A(Q,R) or 2SA1576A(R,S)
- Q210,211 : 2SD1757K
- D201 : DA204U or 1SS302 or MA143A
- D203 : MTZJ8.2(B) or HZS8.2N(B2)
- D204 : MTZJ5.1(B) or HZS5.1N(B2)
- D213 : MA111
- D209 : MTZJ3.3(B) or HZS3.3N(B2)

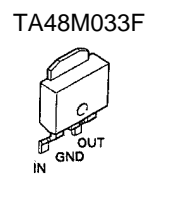
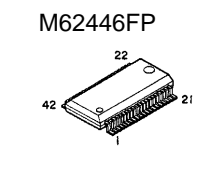
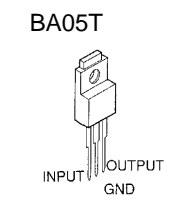
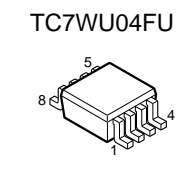
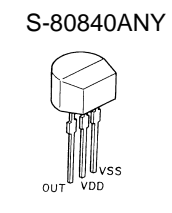
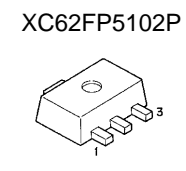
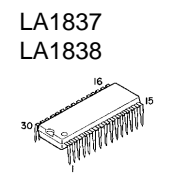
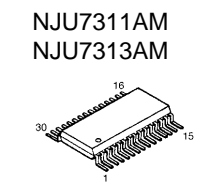
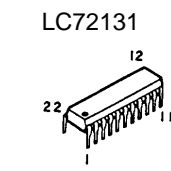
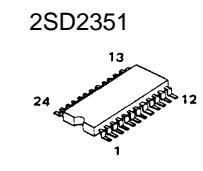
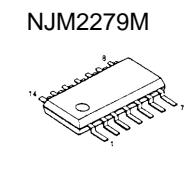
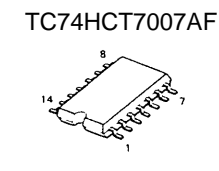
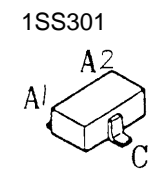
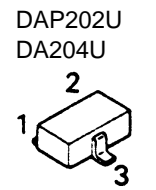
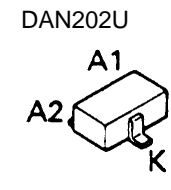
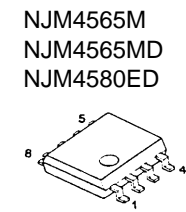
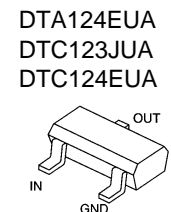
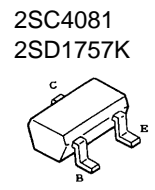
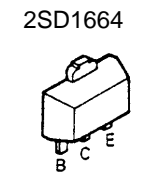
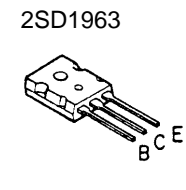

**CAUTION:** For continued safety, replace safety critical components only with manufacturer's recommended parts (refer to parts list).  $\Delta$  indicates safety critical components. For continued protection against risk of fire, replace only with same type and rating fuse(s). To reduce the risk of electric shock, leakage-current or resistance measurements shall be carried out (exposed parts are acceptably insulated from the supply circuit) before the appliance is returned to the customer.

The DC voltage is an actual reading measured with a high impedance type voltmeter as the AM/FM signal generator is specified to the conditions as shown in the list below. The measurement value may vary depending on the measuring instruments used or on the product. The value shown in ( ) is actual reading measured in the AM mode.

MODE	CARRIER	MODULATION		ANT INPUT
		FREQUENCY	DEVIATION	
FM	98MHz	1kHz	STEREO 67.5kHz 7.5kHz(Pilot)	60dB
AM	1000(999)kHz	400Hz	MONO 30% MOD	60dB

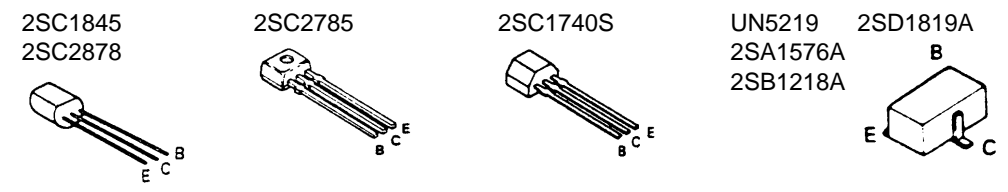

VR-407/407-S/409 (1/4)  
KRF-7030D/7030D-S (1/4)  
KRF-D8030D/8030D-S (1/4)

Y05-4010-10

KENWOOD

KRF-V7030D/V8030D/VR-407/409



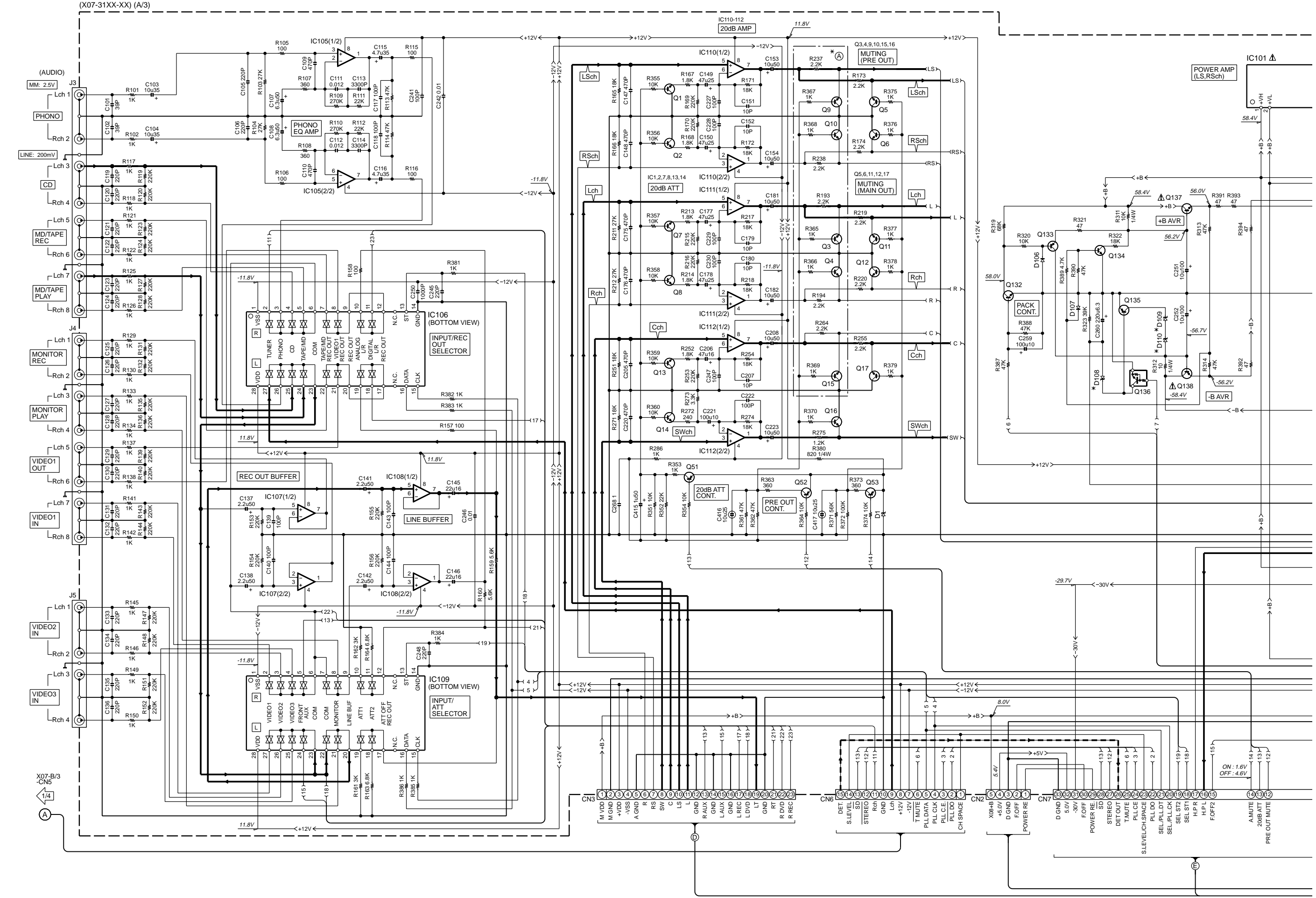

(X07-31XX-XX) (A/3)

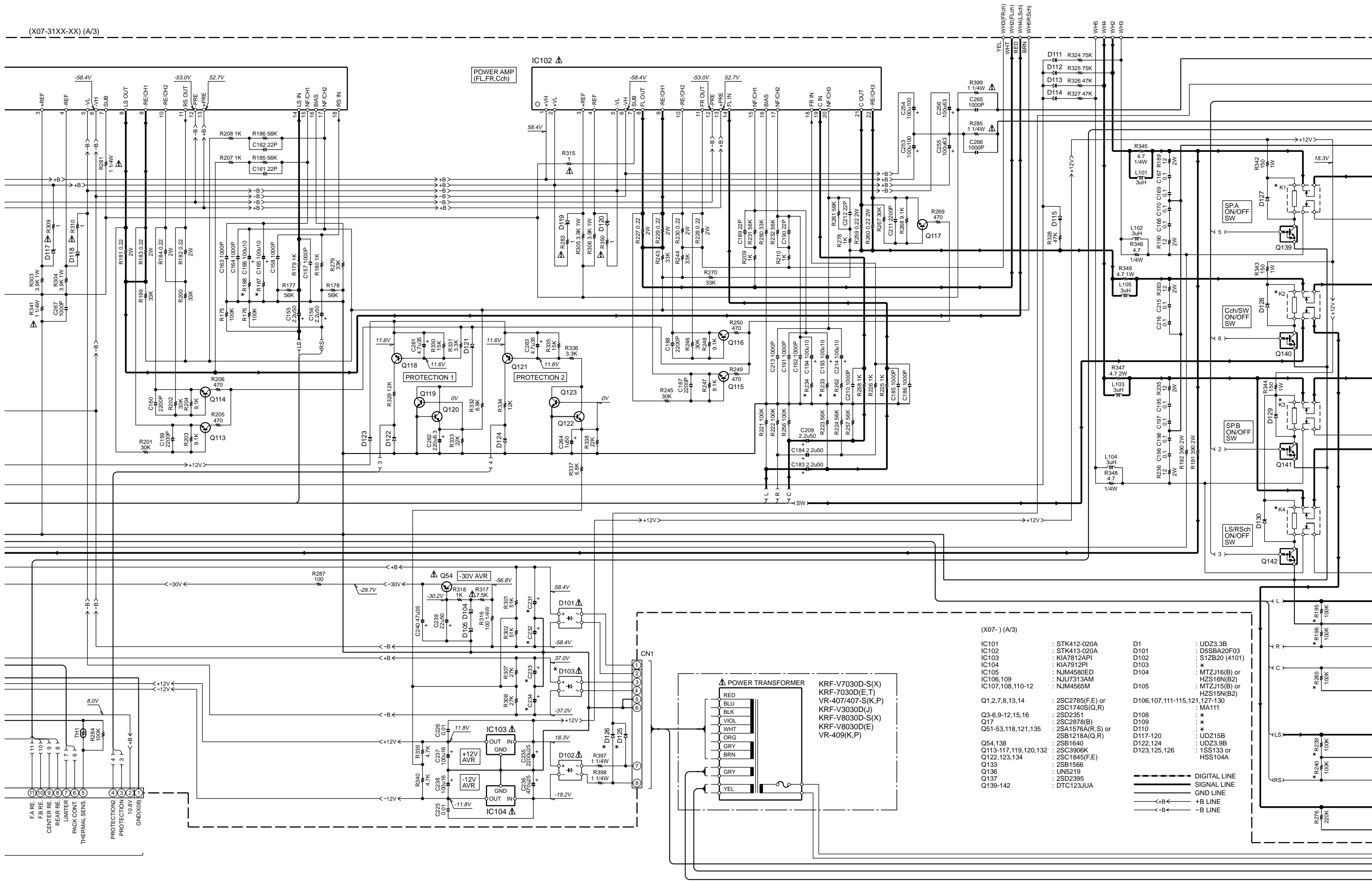

(X07- ) (A/3)

- |                      |                                  |                              |                           |
|----------------------|----------------------------------|------------------------------|---------------------------|
| IC101                | : STK412-020A                    | D1                           | : UDZ3.3B                 |
| IC102                | : STK413-020A                    | D101                         | : D5SBA20F03              |
| IC103                | : KIA7812API                     | D102                         | : S1ZB20 (4101)           |
| IC104                | : KIA7912PI                      | D103                         | : *                       |
| IC105                | : NJM4580ED                      | D104                         | : MTZJ16(B) or HZS16N(B2) |
| IC106,109            | : NJU7313AM                      | D105                         | : MTZJ15(B) or HZS15N(B2) |
| IC107,108,110-12     | : NJM4565M                       | D106,107,111-115,121,127-130 | : MA111                   |
| Q1,2,7,8,13,14       | : 2SC2785(F,E) or 2SC1740S(Q,R)  | D108                         | : *                       |
| Q3-6,9-12,15,16      | : 2SD2351                        | D109                         | : *                       |
| Q17                  | : 2SC2978(B)                     | D110                         | : *                       |
| Q51-53,118,121,135   | : 2SA1576A(R,S) or 2SB1218A(Q,R) | D117-120                     | : UDZ15B                  |
| Q54,138              | : 2SB1640                        | D122,124                     | : UDZ3.9B                 |
| Q113-117,119,120,132 | : 2SC3906K                       | D123,125,126                 | : 1SS133 or HSS104A       |
| Q122,123,134         | : 2SC1845(F,E)                   |                              |                           |
| Q133                 | : 2SB1566                        |                              |                           |
| Q136                 | : UN5219                         |                              |                           |
| Q137                 | : 2SD2395                        |                              |                           |
| Q139-142             | : DTC123JUA                      |                              |                           |

--- DIGITAL LINE  
 --- SIGNAL LINE  
 --- GND LINE  
 <+B< --- +B LINE  
 <-B< --- -B LINE

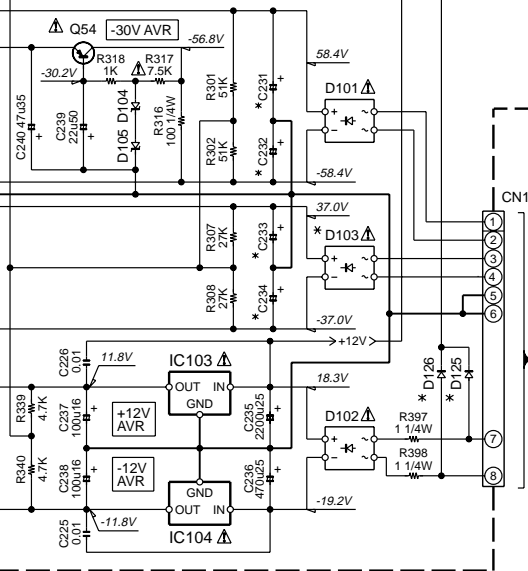
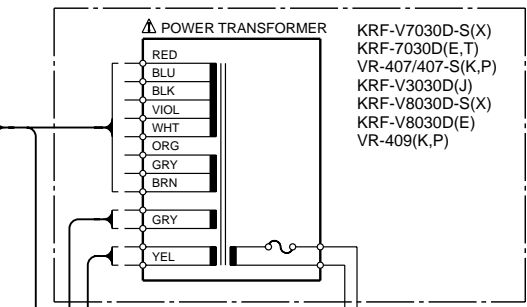

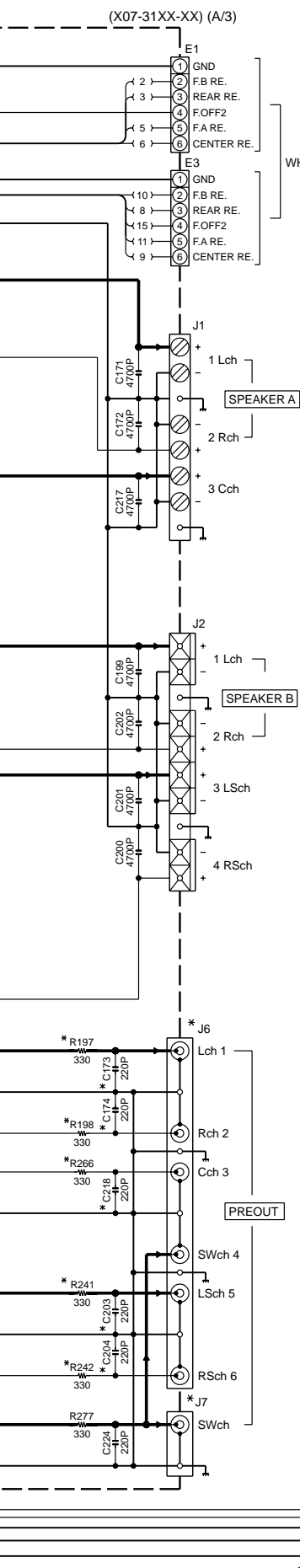

(X07-) (A/3)

VR-409 (X07-3120-11)

DESTINATION	COUNTRY	ABB.	UNIT No.	(A)	C173, 174, 203,204,218	C231, 232	C233, 234	D103	D108	D109	D110	D125, 126	J6	J7	K1-4	R187, 188, 233, 234, 262	R195-198, 239-242, 265, 266
U.S.A.	K	0-11	NO	NO	4700u75	3300u42	D5SBA20F03	UDZ8.2B	UDZ15B	UDZ16B	NO	NO	YES	S76-0042	1.8K	NO	
CANADA	P																

KRF-V8030D (X07-312X-XX)

DESTINATION	COUNTRY	ABB.	UNIT No.	(A)	C173, 174, 203,204,218	C231, 232	C233, 234	D103	D108	D109	D110	D125, 126	J6	J7	K1-4	R187, 188, 233, 234, 262	R195-198, 239-242, 265, 266, 307, 308
PX	Y	2-91	YES	YES	4700u75	3300u42	D5SBA20F03	UDZ8.2B	UDZ15B	UDZ16B	YES	YES	NO	S76-0097	1.8K	YES	
EUROPE	E	2-71	YES	YES	4700u63	3300u35	RBV-602LFA	UDZ6.2B	UDZ10B	UDZ13B	NO	NO	YES	S76-0097	2.4K	YES	

KRF-V8030D-S (X07-312X-XX)

DESTINATION	COUNTRY	ABB.	UNIT No.	(A)	C173, 174, 203,204,218	C231, 232	C233, 234	D103	D108	D109	D110	D125, 126	J6	J7	K1-4	R187, 188, 233, 234, 262	R195-198, 239-242, 265, 266, 307, 308
GENERAL MARKET	M	0-21	YES	YES	4700u75	3300u42	D5SBA20F03	UDZ8.2B	UDZ15B	UDZ16B	YES	YES	NO	S76-0097	1.8K	YES	
MALAYSIA	I	0-21	YES	YES	4700u75	3300u42	D5SBA20F03	UDZ8.2B	UDZ15B	UDZ16B	YES	YES	NO	S76-0097	1.8K	YES	
AUSTRALIA	X	0-71	NO	NO	4700u75	3300u42	D5SBA20F03	UDZ8.2B	UDZ15B	UDZ16B	NO	NO	YES	S76-0042	1.8K	NO	

VR-407 (X07-3130-10)

DESTINATION	COUNTRY	ABB.	UNIT No.	(A)	C173, 174, 203,204,218	C231, 232	C233, 234	D103	D108	D109	D110	D125, 126	J6	J7	K1-4	R187, 188, 233, 234, 262	R195-198, 239-242, 265, 266
U.S.A.	K	0-10	NO	NO	4700u75	3300u42	D5SBA20F03	UDZ8.2B	UDZ15B	UDZ16B	NO	NO	YES	S76-0042	1.8K	NO	
CANADA	P																

VR-407-S (X07-3130-10)

DESTINATION	COUNTRY	ABB.	UNIT No.	(A)	C173, 174, 203,204,218	C231, 232	C233, 234	D103	D108	D109	D110	D125, 126	J6, J7	K1-4	R187, 188, 233, 234, 262	R195-198, 239-242, 265, 266
U.S.A.	K1	0-10	NO	NO	4700u75	3300u42	D5SBA20F03	UDZ8.2B	UDZ15B	UDZ16B	NO	NO	YES	S76-0042	1.8K	NO

KRF-V7030D (X07-313X-XX)

DESTINATION	COUNTRY	ABB.	UNIT No.	(A)	C173, 174, 203,204,218	C231, 232	C233, 234	D103	D108	D109	D110	D125, 126	J6	J7	K1-4	R187, 188, 233, 234, 262	R195-198, 239-242, 265, 266
PX	Y	2-91	YES	NO	4700u75	3300u42	D5SBA20F03	UDZ8.2B	UDZ15B	UDZ16B	YES	YES	NO	YES	S76-0097	1.8K	NO
EUROPE	E1	2-71	NO	NO	4700u63	3300u35	RBV-602LFA	UDZ6.2B	UDZ10B	UDZ13B	NO	NO	YES	S76-0097	2.4K	NO	
U.K.	T	0-51	NO	NO	4700u63	3300u35	RBV-602LFA	UDZ6.2B	UDZ10B	UDZ13B	NO	NO	YES	S76-0097	2.4K	NO	

KRF-V7030D-S (X07-313X-XX)

DESTINATION	COUNTRY	ABB.	UNIT No.	(A)	C173, 174, 203,204,218	C231, 232	C233, 234	D103	D108	D109	D110	D125, 126	J6	J7	K1-4	R187, 188, 233, 234, 262	R195-198, 239-242, 265, 266
GENERAL MARKET	M	0-21	NO	NO	4700u75	3300u42	D5SBA20F03	UDZ8.2B	UDZ15B	UDZ16B	YES	NO	YES	S76-0097	1.8K	NO	
MALAYSIA	I	0-21	NO	NO	4700u75	3300u42	D5SBA20F03	UDZ8.2B	UDZ15B	UDZ16B	YES	NO	YES	S76-0097	1.8K	NO	
AUSTRALIA	X	0-71	NO	NO	4700u75	3300u42	D5SBA20F03	UDZ8.2B	UDZ15B	UDZ16B	NO	NO	YES	S76-0097	1.8K	NO	

(X07-) (C/3)

VR-409 (X07-3120-11)

DESTINATION	COUNTRY	ABB.	UNIT No.	C605	C606	CN62	CN63, 64, 68, 69	D608	F1	F2	IC601	IC602	J61	K601	P61	R602	R604	R609	R610	T1	W23, 250	W63, 251
U.S.A.	K	0-11	NO	0.1	YES	NO	NO	1S133 or HSS104A	F50-0077 8A	NO	YES	NO	E03-0148	S76-0099	YES	30K 1/4W	10 1/4W	27 1/4W	YES	L07-2758 or L07-2761	YES	NO
CANADA	P																					

KRF-V8030D (X07-312X-XX)

DESTINATION	COUNTRY	ABB.	UNIT No.	C605	C606	CN63	CN64	CN62, 68, 69	D608	F1	F2	IC601	IC602	J61	K601	P61	R602	R604	R609	R610	T1	W23	W63, 250, 251	W75
PX	Y	2-91	YES	0.068	YES	YES	NO	NO	RB721Q	F05-3121 T3.15AL	NO	NO	YES	E03-0148	S76-0107	NO	20K 1/4W	NO	2.2 1/4W	NO	L07-2805	NO	YES	NO
EUROPE	E	2-71	NO	0.1	NO	NO	YES	NO	RB721Q	F05-3121 T3.15AL	NO	NO	YES	E03-0149	S76-0107	NO	20K 1/4W	NO	2.2 1/4W	NO	L07-2805	NO	YES	NO
EUROPE	E	2-71	NO	0.1	YES	NO	YES	NO	RB721Q	F05-3121 T3.15AL	NO	NO	YES	E03-0149	S76-0107	NO	20K 1/4W	NO	2.2 1/4W	NO	L07-2805	NO	YES	NO
EUROPE	E	2-71	NO	0.1	YES	NO	YES	NO	RB721Q	F05-3121 T3.15AL	NO	NO	YES	E03-0149	S76-0107	NO	20K 1/4W	NO	2.2 1/4W	NO	L07-2805	NO	YES	NO

KRF-V8030D-S (X07-312X-XX)

DESTINATION	COUNTRY	ABB.	UNIT No.	C605	C606	CN63	CN64	CN62, 68, 69	D608	F1	F2	IC601	IC602	J61	K601	P61	R602	R604	R609	R610	T1	W23	W63, 250, 251	W75	W250
GENERAL MARKET	M	0-21	YES	0.068	NO	YES	YES	NO	RB721Q	F05-3121 T3.15AL	NO	NO	YES	E03-0149	S76-0107	NO	20K 1/4W	NO	2.2 1/4W	NO	L07-2805	NO	YES	NO	YES
MALAYSIA	I	0-21	YES	0.068	NO	YES	YES	NO	RB721Q	F05-3121 T3.15AL	NO	NO	YES	E03-0149	S76-0107	NO	20K 1/4W	NO	2.2 1/4W	NO	L07-2805	NO	YES	NO	YES
AUSTRALIA	X	0-71	NO	0.1	YES	NO	NO	NO	RB721Q	F05-3121 T3.15AL	NO	NO	YES	E03-0325	S76-0107	NO	180K 1/4W	39 1/4W	180 1/4W	NO	L07-2758 or L07-2761	NO	YES	NO	YES

VR-407 (X07-3130-10)

DESTINATION	COUNTRY	ABB.	UNIT No.	C605	C606	CN62	CN63, 64, 68, 69	D608	F1	F2	IC601	IC602	J61	K601	P61	R602	R604	R609	R610	T1	W23, 250	W63, 251
U.S.A.	K	0-10	NO	0.1	YES	NO	NO	1S133 or HSS104A	F50-0077 8A	NO	YES	NO	E03-0148	S76-0099	YES	30K 1/4W	10 1/4W	27 1/4W	YES	L07-2758 or L07-2761	YES	NO
CANADA	P																					

VR-407-S (X07-3130-10)

DESTINATION	COUNTRY	ABB.	UNIT No.	C605	C606	CN62	CN63, 64, 68, 69	D608	F1	F2	IC601	IC602	J61	K601	P61	R602	R604	R609	R610	T1	W23, 250	W63, 251
U.S.A.	K1	0-10	NO	0.1	YES	NO	NO	1S133 or HSS104A	F50-0077 8A	NO	YES	NO	E03-0148	S76-0099	YES	30K 1/4W	10 1/4W	27 1/4W	YES	L07-2758 or L07-2761	YES	NO

KRF-V7030D (X07-313X-XX)

DESTINATION	COUNTRY	ABB.	UNIT No.	C605	C606	CN62	CN63	CN64	CN68, 69	D608	F1	F2	IC601	IC602	J61	K601	P61	R602	R604	R609	R610	T1	W23	W63, 251	W75	W250
PX	Y	2-91	YES	0.068	NO	YES	NO	NO	NO	RB721Q	F05-3121 T3.15AL	NO	NO	YES	E03-0148	S76-0107	NO	20K 1/4W	NO	2.2 1/4W	NO	L07-2805	YES	NO	YES	
EUROPE	E1	2-71	NO	0.1	YES	NO	YES	NO	NO	RB721Q	F05-3121 T3.15AL	NO	NO	YES	E03-0149	S76-0107	NO	20K 1/4W	NO	2.2 1/4W	NO	L07-2805	NO	NO	YES	
U.K.	T	0-51	NO	0.1	YES	NO	YES	NO	NO	RB721Q	F05-3121 T3.15AL	NO	NO	YES	E03-0310	S76-0107	NO	150K 1/4W	39 1/4W	150 1/4W	NO	L07-2758 or L07-2761	NO	NO	YES	

KRF-V7030D-S (X07-313X-XX)

DESTINATION	COUNTRY	ABB.	UNIT No.	C605	C606	CN62	CN63	CN64	CN68, 69	D608	F1	F2	IC601	IC602	J61	K601	P61	R602	R604	R609	R610	T1	W23	W63, 251	W75	W250
GENERAL MARKET	M	0-21	YES	0.068	NO	YES	YES	NO	NO	RB721Q	F05-3121 T3.15AL	NO	NO	YES	E03-0149	S76-0107	NO	20K 1/4W	NO	2.2 1/4W	NO	L07-2805	NO	YES	NO	YES
MALAYSIA	I	0-21	YES	0.068	NO	YES	YES	NO	NO	RB721Q	F05-3121 T3.15AL	NO	NO	YES	E03-0149	S76-0107	NO	20K 1/4W	NO	2.2 1/4W	NO	L07-2805	NO	YES	NO	YES
AUSTRALIA	X	0-71	NO	0.1	YES	NO	NO	NO	NO	RB721Q	F05-3121 T3.15AL	NO	NO	YES	E03-0325	S76-0107	NO	180K 1/4W	39 1/4W	180 1/4W	NO	L07-2758 or L07-2761	NO	YES	NO	YES

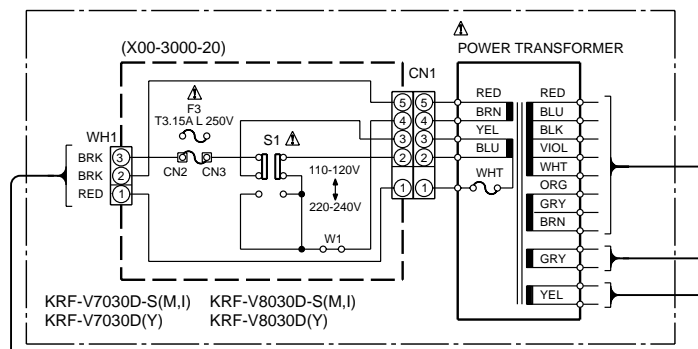

(X07-) (C/3)

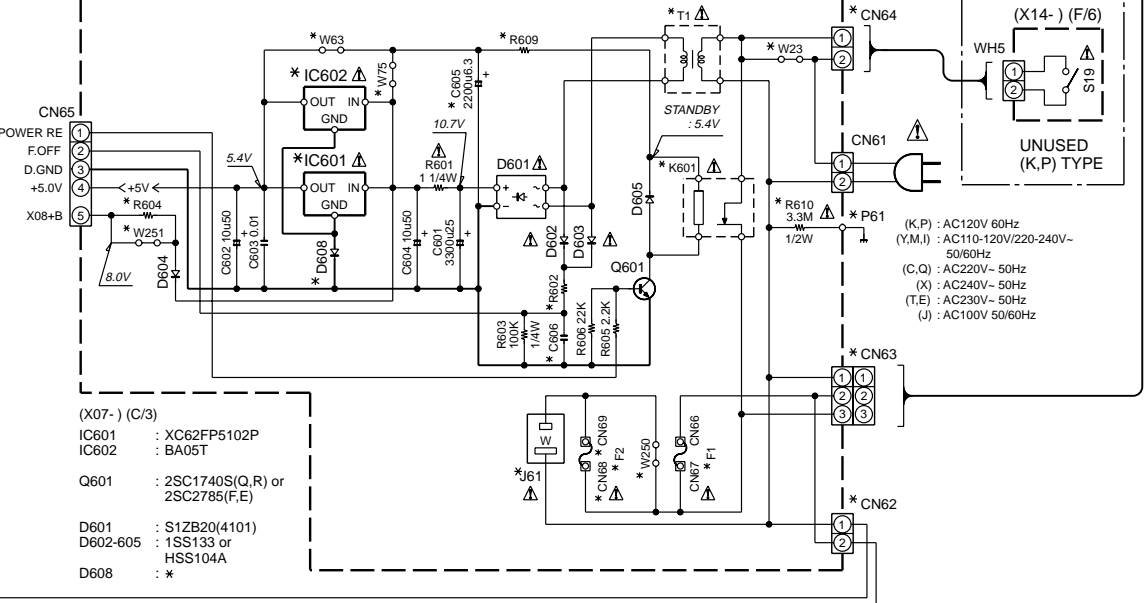

(X07-) (C/3)

IC601	: XC62FP5102P
IC602	: BA05T
Q601	: 2SC1740S(Q,R) or 2SC2785(F,E)
D601	: S1ZB20(4101)
D602-605	: 1S133 or HSS104A
D608	: *

**CAUTION:** For continued safety, replace safety critical components only with manufacturer's recommended parts (refer to parts list).  $\Delta$  indicates safety critical components. For continued protection against risk of fire, replace only with same type and rating fuse(s). To reduce the risk of electric shock, leakage-current or resistance measurements shall be carried out (exposed parts are acceptably insulated from the supply circuit) before the appliance is returned to the customer.

The DC voltage is an actual reading measured with a high impedance type voltmeter with a cassette loaded at playback mode. The measurement value may vary depending on the measuring instruments used or on the product. Bias circuit DC voltage is measured while in the record mode.

DOLBY and the double-D symbol are trademarks of Dolby Laboratories Licensing Corporation. Noise reduction circuit made under license from Dolby Laboratories Licensing Corporation.

VR-407/407-S/409 (2/4)  
KRF-V7030D/V7030D-S (2/4)  
KRF-V8030D/V8030D-S (2/4)

KRF-V7030D/V8030D/VR-407/409





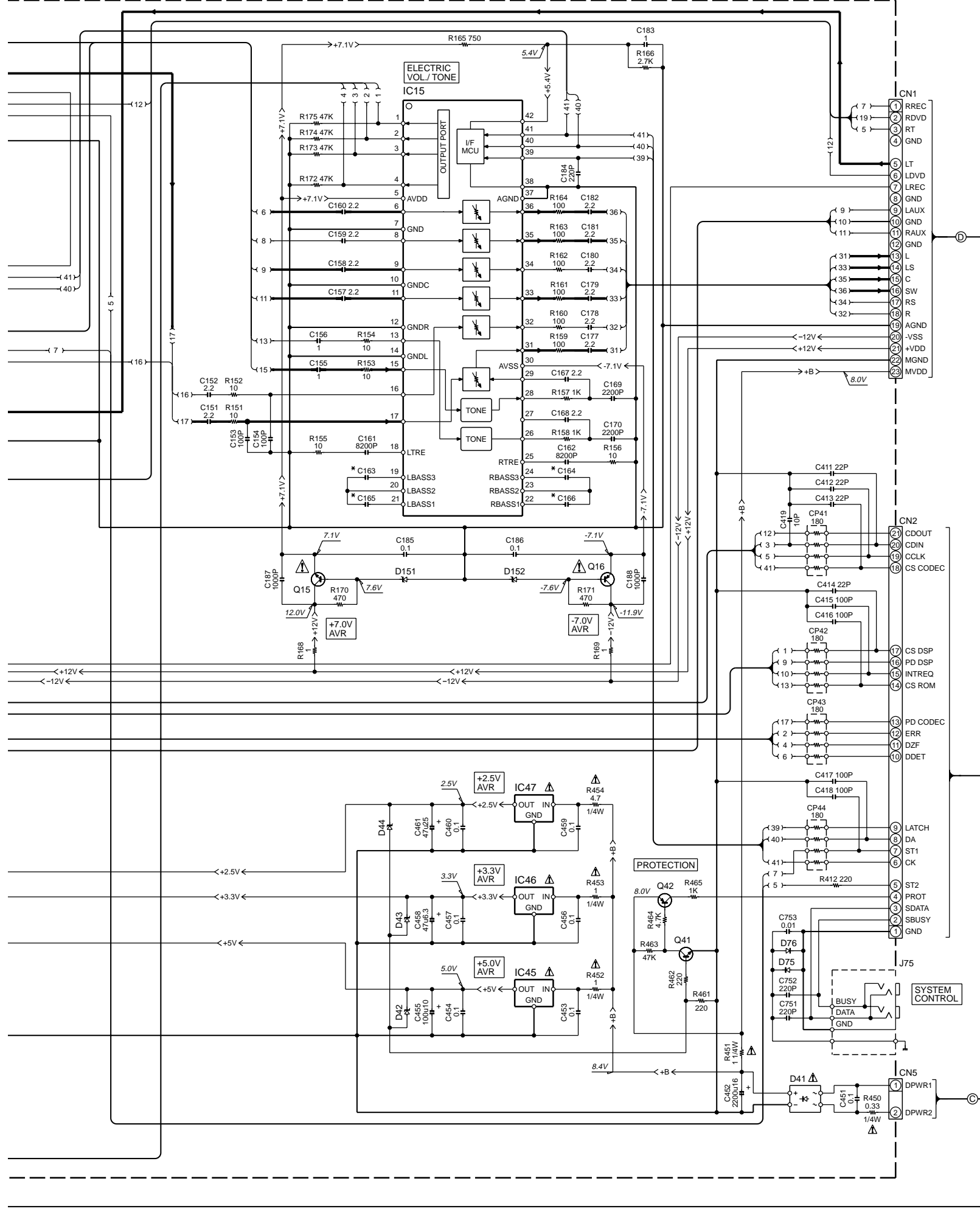

VR-407 (X08-3010-12)

DESTINATION	UNIT	IC43, 44	R428	R37,38,433, 434,635,636	R633,634	C37	C163, 164	C165, 166	C209	A3	
U.S.A.	K	0-12	NO	YES	NO	100 1W	NO	0.015	0.33	YES	NO
CANADA	P	0-12	NO	YES	NO	100 1W	NO	0.015	0.33	YES	NO

KRF-V7030D-S (X08-301X-XX)

DESTINATION	UNIT	IC43, 44	R428	R37,38, 433,434	R633,634	R635,636	C37	C163, 164	C165, 166	C209	A3
GENERAL MARKET	M	0-22	NO	YES	NO	47 1W	YES	NO	0.033	0.47	NO
MALAYSIA	I	0-12	NO	YES	NO	100 1W	NO	NO	0.015	0.33	YES
AUSTRALIA	X	0-12	NO	YES	NO	100 1W	NO	NO	0.015	0.33	YES

KRF-V7030D (X08-3010-12)

DESTINATION	UNIT	IC43, 44	R428	R37,38,433, 434,635,636	R633,634	C37	C163, 164	C165, 166	C209	A3	
U.S.A.	K	0-12	NO	YES	NO	100 1W	NO	0.015	0.33	YES	NO
U.K.	T	0-12	NO	YES	NO	100 1W	NO	0.015	0.33	YES	NO
EUROPE	E1	0-12	NO	YES	NO	100 1W	NO	0.015	0.33	YES	NO

VR-407-S (X08-3010-12)

DESTINATION	UNIT	IC43, 44	R428	R37,38,433, 434,635,636	R633,634	C37	C163, 164	C165, 166	C209	A3	
U.S.A.	K1	0-12	NO	YES	NO	100 1W	NO	0.015	0.33	YES	NO

VR-409 (X08-3010-13)

DESTINATION	UNIT	IC43, 44	R37,38, 433,434	R428, 635,636	R633,634	C37	C163, 164	C165, 166	C209	A3	
U.S.A.	K	0-13	YES	YES	NO	100 1W	YES	0.015	0.33	YES	YES
CANADA	P	0-13	YES	YES	NO	100 1W	YES	0.015	0.33	YES	YES

KRF-V8030D (X08-3010-13)

DESTINATION	UNIT	IC43, 44	R37,38, 433,434	R428, 635,636	R633,634	C37	C163, 164	C165, 166	C209	A3	
U.S.A.	Y	0-13	YES	YES	NO	100 1W	YES	0.015	0.33	YES	YES
EUROPE	E	0-13	YES	YES	NO	100 1W	YES	0.015	0.33	YES	YES

KRF-V8030D-S (X08-301X-XX)

DESTINATION	UNIT	IC43, 44	R37,38, 433,434	R428	R633,634	R635,636	C37	C163, 164	C165, 166	C209	A3
GENERAL MARKET	M	0-23	YES	YES	NO	47 1W	YES	NO	0.033	0.47	NO
MALAYSIA	I	0-13	YES	YES	NO	100 1W	NO	NO	0.015	0.33	YES
AUSTRALIA	X	0-13	YES	YES	NO	100 1W	NO	NO	0.015	0.33	YES

- IC1,11,13,21,31 : NJM4565MD Q1 : DTC124EUA or UN5212  
 IC2 : AK4527-VQ Q15,61 : 2SD1664(Q,R) or 2SD1963(R,S)-G  
 IC4 : TC7WU04FU Q16,62 : 2SB1132(Q,R) or 2SB1308(Q,R)-G  
 IC5 : AK4110-VF Q41 : 2SC4081(R,S) or 2SD1819A(Q,R)  
 IC6 : TC7WH123FU Q42 : 2SA1576A(R,S) or 2SB1218A(Q,R)  
 IC12,14 : NJM7311AM  
 IC15 : M62446FP  
 IC41 : TC74HC07AF  
 IC42 : TC74HCT7007AF  
 IC43 : TC7WH126FU  
 IC44 : AT25256WS2701  
 IC45 : TA48M05F D1,3 : 1SS301 or DAN202U or MA142WK  
 IC46 : TA48M033F  
 IC47 : TA48M025F D2 : 1SS300 or DAP202U or MA142WA  
 IC51 : CS493263-CLR  
 IC61 : NJM2279M  
 IC62 : TC74HC4052AFT or NJU4052BV D6,51,52,75,76 : MA111  
 D41 : S1ZB20(4072)  
 D42,43,61,62 : UDZ5.6B  
 D44 : UDZ3.9B  
 D151,152 : UDZ7.5B

— SIGNAL LINE  
 — GND LINE  
 — +B LINE  
 — -B LINE

**CAUTION:** For continued safety, replace safety critical components only with manufacturer's recommended parts (refer to parts list).  $\Delta$  indicates safety critical components. For continued protection against risk of fire, replace only with same type and rating fuse(s). To reduce the risk of electric shock, leakage-current or resistance measurements shall be carried out (exposed parts are acceptably insulated from the supply circuit) before the appliance is returned to the customer.

The DC voltage is an actual reading measured with a high impedance type voltmeter with a cassette loaded at playback mode. The measurement value may vary depending on the measuring instruments used or on the product. Bias circuit DC voltage is measured while in the record mode.

(X14-7XXX-XX) (A/6)

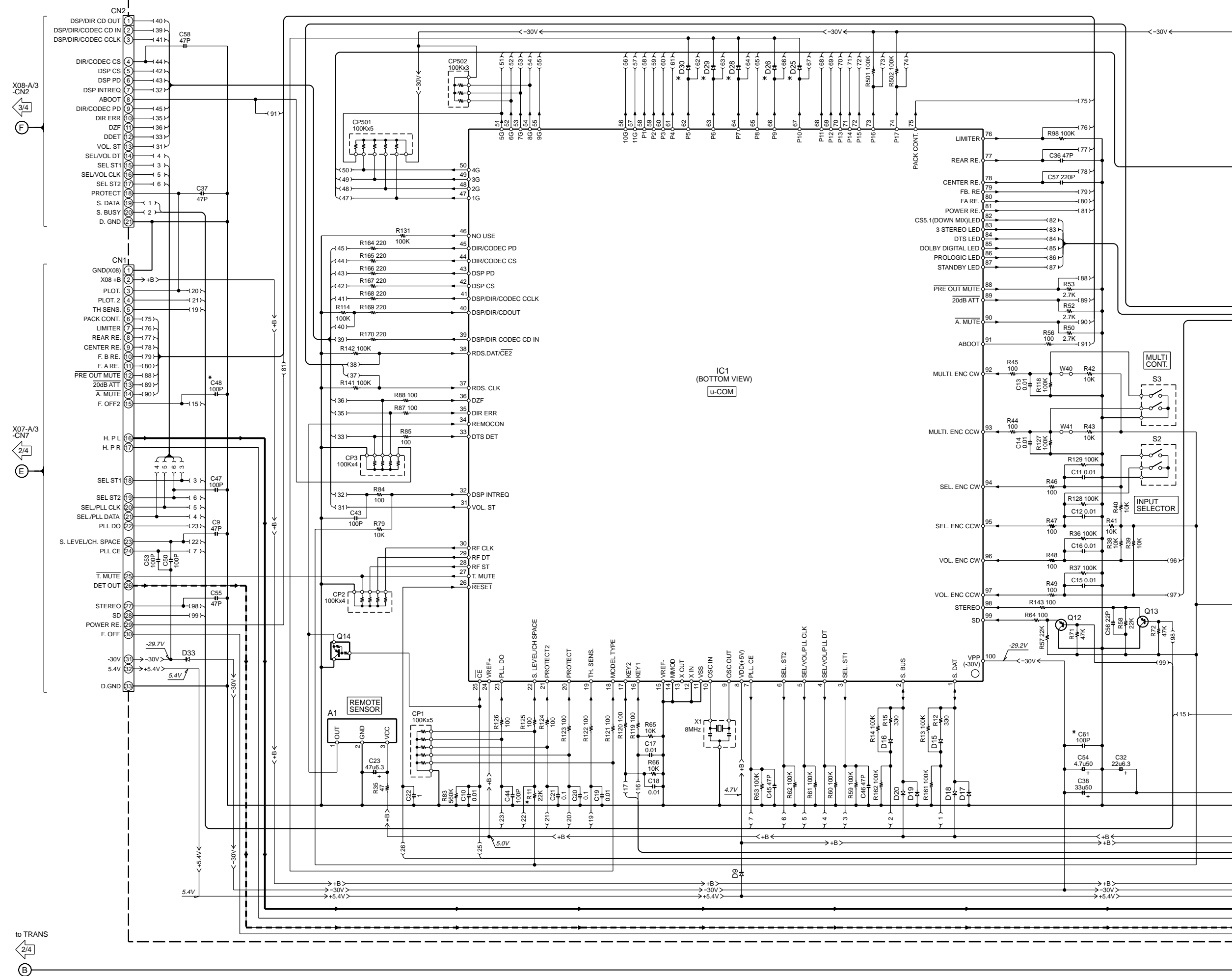

X08-A/3  
CN2  
3/4  
F

X07-A/3  
CN7  
2/4  
E

to TRANS  
2/4  
B

IC1  
(BOTTOM VIEW)  
U-COM

REMOTE SENSOR  
A1

MULTI CONT.  
S3

MULTI CONT.  
S2

INPUT SELECTOR  
S1

1  
2  
3  
4  
5  
6  
7

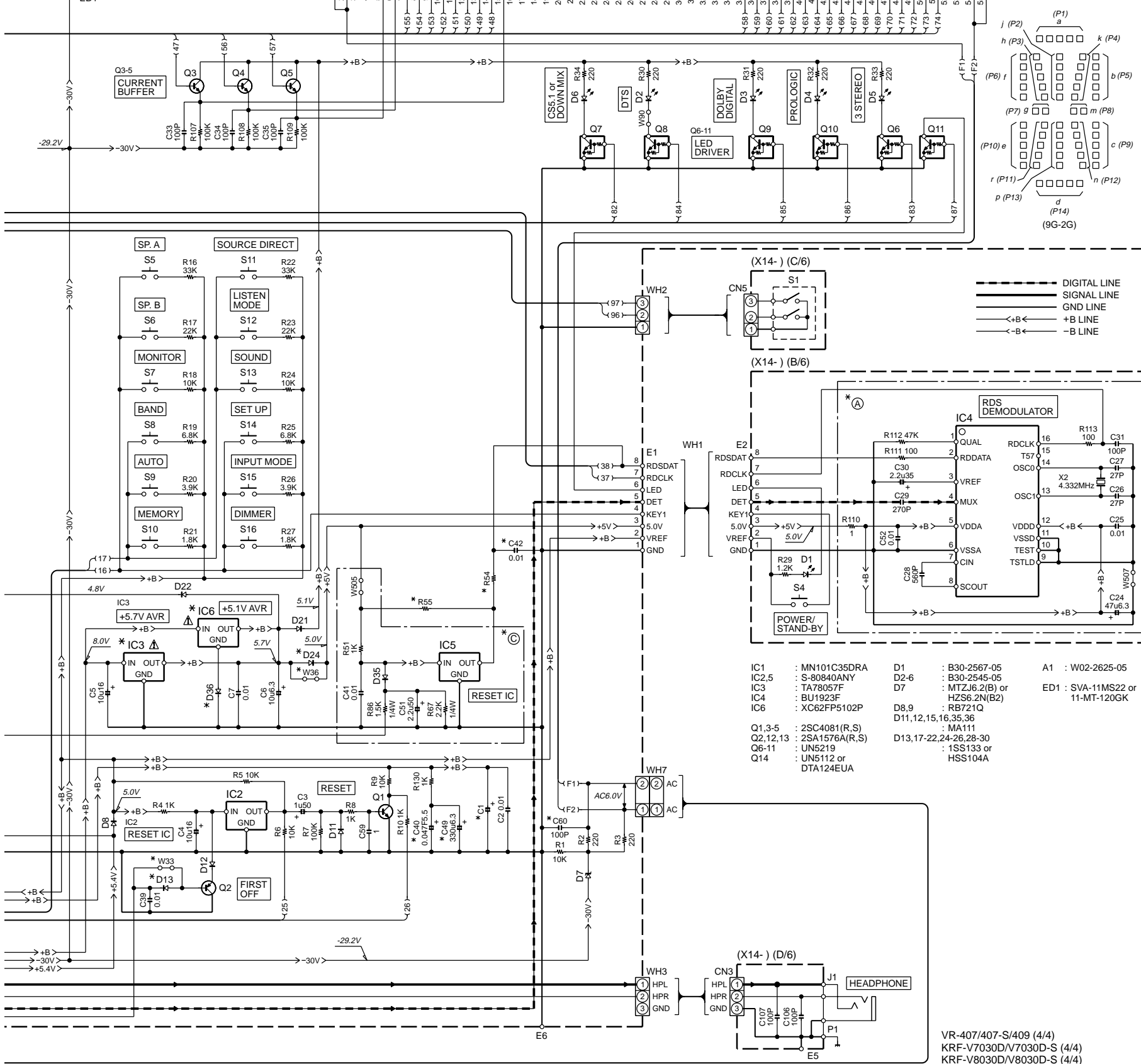
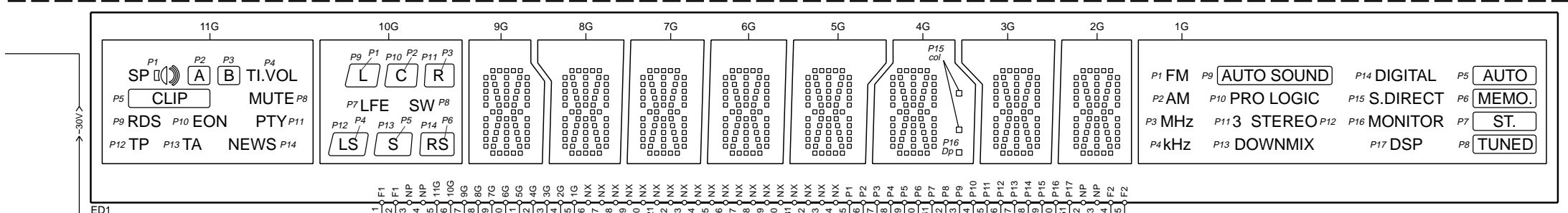

VR-409 (X14-7090-11)

DESTINATION	COUNTRY	ABB.	UNIT No.	(A)	(B)	(C)	C1	C40,42,48,60,61	C49	D13,26	D24,25,28-30,36	IC3	IC6	R11,54,55	S3	S17,18	W33,36	W40,41
U.S.A.	K	P	0-11	NO	NO	NO	330u6.3	NO	YES	YES	NO	YES	NO	NO	YES	NO	NO	YES
CANADA	P	P	2-71	YES	NO	NO	100u10	YES	YES	NO	NO	NO	NO	NO	NO	NO	NO	NO

KRF-V8030D (X14-709X-XX)

DESTINATION	COUNTRY	ABB.	UNIT No.	(A)	(B)	(C)	C1	C40	C42,48,60	C49	C61	D13,25,29	D24,30	D26,28	D36,36	IC3	IC6	R11	R54,55	S3	S17,18	W33,40,41	W36	
PX	Y	Y	0-21	NO	NO	NO	100u10	YES	YES	NO	NO	NO	NO	NO	NO	NO	NO	YES	YES	10K	YES	NO	YES	NO
EUROPE	E	E	2-71	YES	NO	NO	100u10	YES	NO	NO	NO	NO	NO	NO	NO	NO	NO	NO	NO	NO	NO	NO	NO	NO

KRF-V8030D-S (X14-709X-XX)

DESTINATION	COUNTRY	ABB.	UNIT No.	(A)	(B)	(C)	C1	C40,42	C48	C49,60,61	D13,25,30	D24	D26,28	D29	D36,36	IC3	IC6	R11	R54,55	S3	S17,18	W33,40,41	W36	
GENERAL MARKET	M	M	0-21	NO	YES	NO	100u10	YES	YES	NO	NO	NO	NO	NO	NO	NO	NO	YES	YES	10K	YES	NO	YES	NO
MALAYSIA	I	I	0-21	NO	YES	NO	100u10	YES	YES	NO	NO	NO	NO	NO	NO	NO	NO	YES	YES	10K	YES	NO	YES	NO
AUSTRALIA	X	X	0-71	NO	NO	NO	100u10	YES	NO	NO	NO	NO	NO	NO	NO	NO	NO	NO	NO	4.7K	YES	NO	YES	NO

VR-407 (X14-7090-12)

DESTINATION	COUNTRY	ABB.	UNIT No.	(A)	(B)	(C)	C1	C40,42,48,60,61	C49	D13,25	D24,26,28-30,36	IC3	IC6	R11,54,55	S3	S17,18	W33,36	W40,41	
U.S.A.	K	P	0-12	NO	NO	NO	330u6.3	NO	YES	YES	NO	YES	NO	NO	YES	NO	NO	NO	YES
CANADA	P	P	2-71	YES	NO	NO	100u10	YES	YES	NO	NO	NO	NO	NO	NO	NO	NO	NO	NO

VR-407-S (X14-7090-12)

DESTINATION	COUNTRY	ABB.	UNIT No.	(A)	(B)	(C)	C1	C40,42,48,60,61	C49	D13,25	D24,26,28-30,36	IC3	IC6	R11,54,55	S3	S17,18	W33,36	W40,41	
U.S.A.	K	P	0-12	NO	NO	NO	330u6.3	NO	YES	YES	NO	YES	NO	NO	YES	NO	NO	NO	YES

KRF-V7030D (X14-709X-XX)

DESTINATION	COUNTRY	ABB.	UNIT No.	(A)	(B)	(C)	C1	C40,108-115	C42,48	C49,60	C61	D13,26,29	D24,30	D25,28	D36	IC3	IC6	R11	R54,55	S3	S17,18	W33,40,41	W36	
PX	Y	Y	0-22	NO	NO	NO	100u10	YES	YES	NO	NO	NO	NO	NO	NO	NO	NO	YES	YES	10K	YES	NO	YES	NO
EUROPE	E1	E1	2-72	YES	NO	NO	100u10	YES	NO	NO	NO	NO	NO	NO	NO	NO	NO	NO	NO	NO	NO	NO	NO	NO
U.K.	T	T	2-72	YES	NO	NO	100u10	YES	NO	NO	NO	NO	NO	NO	NO	NO	NO	NO	NO	NO	NO	NO	NO	NO

KRF-V7030D-S (X14-709X-XX)

DESTINATION	COUNTRY	ABB.	UNIT No.	(A)	(B)	(C)	C1	C40,108-115	C48	C49,60,61	D13,26,30	D24	D25,28	D29	D36	IC3	IC6	R11	R54,55	S3	S17,18	W33,40,41	W36	
GENERAL MARKET	M	M	0-22	NO	YES	NO	100u10	YES	YES	NO	NO	NO	NO	NO	NO	NO	NO	YES	YES	10K	YES	NO	YES	NO
MALAYSIA	I	I	0-22	NO	YES	NO	100u10	YES	YES	NO	NO	NO	NO	NO	NO	NO	NO	YES	YES	10K	YES	NO	YES	NO
AUSTRALIA	X	X	0-72	NO	NO	NO	100u10	YES	NO	NO	NO	NO	NO	NO	NO	NO	NO	NO	NO	4.7K	YES	NO	YES	NO

**CAUTION:** For continued safety, replace safety critical components only with manufacturer's recommended parts (refer to parts list).  $\Delta$  indicates safety critical components. For continued protection against risk of fire, replace only with same type and rating fuse(s). To reduce the risk of electric shock, leakage-current or resistance measurements shall be carried out (exposed parts are acceptably insulated from the supply circuit) before the appliance is returned to the customer.

The DC voltage is an actual reading measured with a high impedance type voltmeter with a cassette loaded at playback mode. The measurement value may vary depending on the measuring instruments used or on the product. Bias circuit DC voltage is measured while in the record mode.

- IC1 : MN101C35DRA
- IC2,5 : S-80840ANY
- IC3 : TA78057F
- IC4 : BU1923F
- IC6 : XC62FP5102P
- D1 : B30-2567-05
- D2-6 : B30-2545-05
- D7 : MTZ16.2(B) or HZS6.2N(B2)
- D8,9 : RB721Q
- D11,12,15,16,35,36 : MA111
- D13,17-22,24-26,28-30 : 1SS133 or HSS104A
- A1 : W02-2625-05
- ED1 : SVA-11MS22 or 11-MT-120GK

VR-407/407-S/409 (4/4)  
KRF-V7030D/V7030D-S (4/4)  
KRF-V8030D/V8030D-S (4/4)

Y05-4010-10

KRF-V7030D/V8030D/VR-407/409

KENWOOD



A

B

C

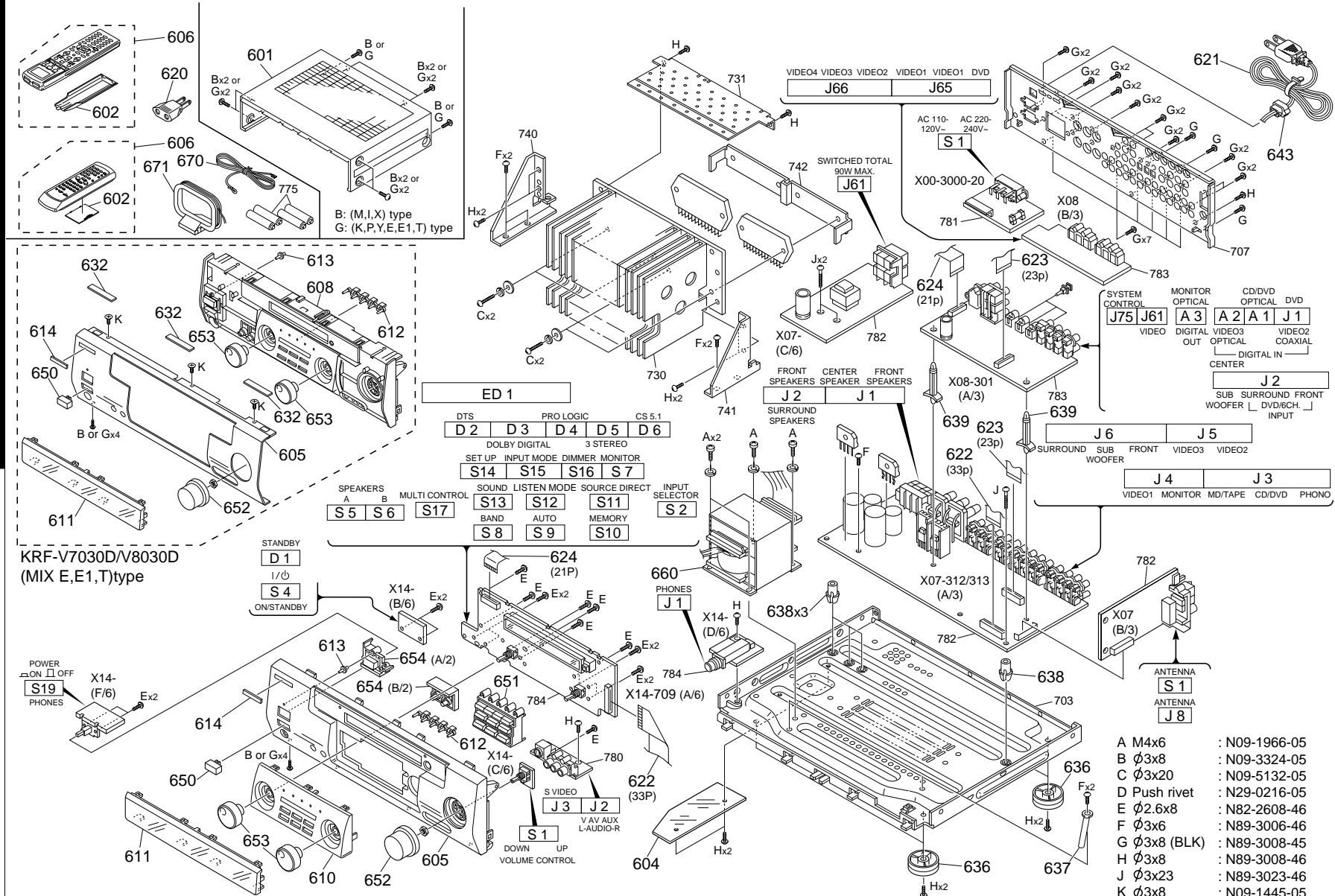

KRF-V7030D/V8030D (MIX E,E1,T)type

POWER ON/OFF S19 PHONES X14-(F/6) EX2

STANDBY D1 I/ON STANDBY S4

ED 1

D2	D3	D4	D5	D6
----	----	----	----	----

DTS PRO LOGIC CS 5.1  
DOLBY DIGITAL 3 STEREO

S14	S15	S16	S7
-----	-----	-----	----

SET UP INPUT MODE DIMMER MONITOR

S13	S12	S11
S8	S9	S10

SOUND LISTEN MODE SOURCE DIRECT INPUT SELECTOR

S5	S6	S17
----	----	-----

SPEAKERS MULTI CONTROL

S13	S12	S11
S8	S9	S10

BAND AUTO MEMORY

- A M4x6 : N09-1966-05
- B Ø3x8 : N09-3324-05
- C Ø3x20 : N09-5132-05
- D Push rivet : N29-0216-05
- E Ø2.6x8 : N82-2608-46
- F Ø3x6 : N89-3006-46
- G Ø3x8 (BLK) : N89-3008-45
- H Ø3x8 : N89-3008-46
- J Ø3x23 : N89-3023-46
- K Ø3x8 : N09-1445-05

KRF-V8030D,V7030D/VR-409,407

EXPLODED VIEW (UNIT)

KRF-V7030D/V8030D/VR-407/409

\* New Parts

Parts without **Parts No.** are not supplied.  
 Les articles non mentionnés dans le **Parts No.** ne sont pas fournis.  
 Teile ohne **Parts No.** werden nicht geliefert.

①

Ref. No	Add-ress	New Parts	Parts No.	Description	Desti-nation	Re-marks
<b>KRF-V7030D/V8030D</b>						
601	1A	*	A01-3731-01	METALLIC CABINET		
602	1A	*	A09-1166-08	BATTERY COVER	E	
602	1A	*	A09-1178-08	BATTERY COVER	E1T	
604	2B	*	A46-0309-04	REAR COVER		
605	1A,2A	*	A60-1744-12	PANEL		
606	1A	*	A70-1331-05	REMOTE CONTROL ASSY(RC-R0610)	E1T	
606	1A	*	A70-1345-05	REMOTE CONTROL ASSY(RC-R0808)	E	
608	1A	*	A22-1833-11	SUB PANEL	E	
608	1A	*	A22-1835-11	SUB PANEL	E1T	
611	2A	*	B10-3545-02	FRONT GLASS	E	
611	2A	*	B10-3548-02	FRONT GLASS	E1T	
612	1A,2B	*	B12-0383-04	INDICATOR		
613	1A,2B	*	B12-0341-04	INDICATOR		
614	2A	*	B43-0314-04	KENWOOD BADGE		
-			B46-0310-03	WARRANTY CARD	T	
-			B58-0945-03	CAUTION CARD	T	
-			B58-0965-13	CAUTION CARD (T,XtypePL)	EE1	
-			B58-0966-13	CAUTION CARD (ELMtypePL)	E	
-		*	B60-4595-00	INSTRUCTION MANUAL (ES)	E	
-		*	B60-4596-00	INSTRUCTION MANUAL (FR)	E	
-		*	B60-4597-00	INSTRUCTION MANUAL (GE/NE/IT)	E	
-		*	B60-4602-00	INSTRUCTION MANUAL (EN)	T	
-		*	B60-4603-00	INSTRUCTION MANUAL (ES)	E1	
-		*	B60-4604-00	INSTRUCTION MANUAL (FR/GE)	E1	
-		*	B60-4605-00	INSTRUCTION MANUAL (IT/NE)	E1	
-		*	B60-4615-00	INSTRUCTION MANUAL (5-LAN)	E	
-		*	B60-4622-00	INSTRUCTION MANUAL (5-LAN)	E1	
-		*	B60-4624-00	INSTRUCTION MANUAL (EN)	T	
△ 621	1C	*	E30-2721-05	AC POWER CORD	T	
△ 621	1C	*	E30-2942-05	AC POWER CORD	EE1	
622	1C,2B	*	E35-2456-05	FLAT CABLE (33P)		
623	1C	*	E35-2480-05	FLAT CABLE (23P)		
624	1C,2B	*	E35-2613-05	FLAT CABLE (21P)		
632	1A		G10-0481-04	NON-WOVEN FABRIC		
-			G11-2416-04	CUSHION		
-		*	H10-7628-02	POLYSTYRENE FOAMED FIXTURE		
-		*	H10-7629-02	POLYSTYRENE FOAMED FIXTURE		
-		*	H25-0232-04	PROTECTION BAG (235X350X0.03)	EE1	
-		*	H25-0391-04	PROTECTION BAG		
-		*	H25-0651-04	PROTECTION BAG (0232 PRINT)	T	
-		*	H50-3599-04	ITEM CARTON CASE	E	
-		*	H50-3604-04	ITEM CARTON CASE	E1T	
636	2C	*	J02-1464-03	FOOT		
637	2C	*	J19-2808-05	HOLDER		
638	2B,2C	*	J19-3752-14	UNIT HOLDER		
639	1C	*	J19-6078-05	UNIT HOLDER		
△ 643	1C	*	J42-0083-05	POWER CORD BUSHING		
-			J61-0307-05	WIRE BAND		
650	2A	*	K27-2384-04	KNOB (BUTTON)		
651	2B	*	K29-7675-12	KNOB		
652	2A	*	K29-7678-04	KNOB (VOLUME)		

L : Scandinavia K : USA P : Canada R : Mexico C : China I : Malaysia  
 Y : PX(Far East,Hawaii) T : England G : Germany V : China(Shanghai)  
 Y : AAFES(Europe) X : Australia Q : Russia H : Korea M : Other Areas △ indicates safety critical components .

\* New Parts

Parts without **Parts No.** are not supplied.  
 Les articles non mentionnés dans le **Parts No.** ne sont pas fournis.  
 Teile ohne **Parts No.** werden nicht geliefert.

②

Ref. No	Add-ress	New Parts	Parts No.	Description	Desti-nation	Re-marks
653	1A,2A	*	K29-7681-14	KNOB (MULTI/INPUT)		
△ 660	2B	*	L07-2790-05	POWER TRANSFORMER		
670	1A	*	T90-0836-05	LEAD WIRE ANTENNA		
671	1A	*	T90-0852-05	LOOP ANTENNA		
<b>KRF-V8030D-S</b>						
601	1A	*	A01-3732-01	METALLIC CABINET		
602	1A	*	A09-1166-08	BATTERY COVER		
604	2B	*	A46-0309-04	REAR COVER		
605	1A,2A	*	A60-1743-12	PANEL		
606	1A	*	A70-1315-05	REMOTE CONTROL ASSY(RC-R0809)		
608	1A	*	A22-1834-11	SUB PANEL		
611	2A	*	B10-3544-02	FRONT GLASS		
612	1A,2B	*	B12-0383-04	INDICATOR		
613	1A,2B	*	B12-0341-04	INDICATOR		
614	2A	*	B43-0314-04	KENWOOD BADGE		
-			B46-0096-53	WARRANTY CARD		
-			B58-0965-13	CAUTION CARD (T,XtypePL)		X
-			B58-0966-13	CAUTION CARD (ELMtypePL)		MI
-		*	B60-4593-00	INSTRUCTION MANUAL (EN)		MI
-		*	B60-4594-00	INSTRUCTION MANUAL (TC)		M
-		*	B60-4595-00	INSTRUCTION MANUAL (ES)		M
-		*	B60-4611-00	INSTRUCTION MANUAL (EN)		MI
-		*	B60-4612-00	INSTRUCTION MANUAL (TC)		M
-		*	B60-4613-00	INSTRUCTION MANUAL (ES)		M
△ 620	1A	*	E03-0115-05	AC PLUG ADAPTER		M
△ 621	1C	*	E30-2717-05	AC POWER CORD		X
△ 621	1C	*	E30-2942-05	AC POWER CORD		MI
622	1C,2B	*	E35-2456-05	FLAT CABLE (33P)		
623	1C	*	E35-2480-05	FLAT CABLE (23P)		
624	1C,2B	*	E35-2613-05	FLAT CABLE (21P)		
632	1A		G10-0481-04	NON-WOVEN FABRIC		
-			G11-2416-04	CUSHION		
-		*	H10-7628-02	POLYSTYRENE FOAMED FIXTURE		
-		*	H10-7629-02	POLYSTYRENE FOAMED FIXTURE		
-		*	H25-0232-04	PROTECTION BAG (235X350X0.03)		
-		*	H25-0391-04	PROTECTION BAG		
-		*	H50-3600-04	ITEM CARTON CASE		X
-		*	H50-3601-04	ITEM CARTON CASE		MI
636	2C	*	J02-1464-03	FOOT		
637	2C	*	J19-2808-05	HOLDER		
638	2B,2C	*	J19-3752-14	UNIT HOLDER		
639	1C	*	J19-6078-05	UNIT HOLDER		
△ 643	1C	*	J42-0083-05	POWER CORD BUSHING		
-			J61-0307-05	WIRE BAND		
650	2A	*	K27-2385-04	KNOB (BUTTON)		
651	2B	*	K29-7676-12	KNOB		
652	2A	*	K29-7679-04	KNOB (VOLUME)		
653	1A,2A	*	K29-7682-14	KNOB (MULTI/INPUT)		
△ 660	2B	*	L07-2788-05	POWER TRANSFORMER		MI

L : Scandinavia K : USA P : Canada R : Mexico C : China I : Malaysia  
 Y : PX(Far East,Hawaii) T : England G : Germany V : China(Shanghai)  
 Y : AAFES(Europe) X : Australia Q : Russia H : Korea M : Other Areas △ indicates safety critical components .

\* New Parts  
Parts without **Parts No.** are not supplied.  
Les articles non mentionnés dans le **Parts No.** ne sont pas fournis.  
Teile ohne **Parts No.** werden nicht geliefert.

③

Ref. No	Add-ress	New Parts	Parts No.	Description	Desti-nation	Re-marks
△ 660	2B	*	L07-2789-05	POWER TRANSFORMER	X	
670	1A	*	T90-0836-05	LEAD WIRE ANTENNA		
671	1A	*	T90-0852-05	LOOP ANTENNA		
<b>VR-409/KRF-V8030D</b>						
601	1A	*	A01-3733-01	METALLIC CABINET		
602	1A	*	A09-1166-08	BATTERY COVER		
604	2B	*	A46-0309-04	REAR COVER		
605	1A,2A	*	A60-1736-11	PANEL	KP	
605	1A,2A	*	A60-1737-11	PANEL	Y	
606	1A	*	A70-1315-05	REMOTE CONTROL ASSY(RC-R0809)		
610	2A	*	B07-2475-02	ESCUTCHEON		
611	2A	*	B10-3543-02	FRONT GLASS	KP	
611	2A	*	B10-3544-02	FRONT GLASS	Y	
612	1A,2B	*	B12-0383-04	INDICATOR		
613	1A,2B	*	B12-0385-04	INDICATOR		
614	1A,2A		B43-0314-04	KENWOOD BADGE		
-			B46-0328-03	WARRANTY CARD	KY	
-			B46-0346-00	QUESTIONNAIRE CARD	K	
-			B46-0347-03	WARRANTY CARD	P	
-			B58-0513-04	CAUTION CARD (PRESET220-240)	Y	
-			B58-0964-13	CAUTION CARD (UL)	KY	
-		*	B58-0967-03	CAUTION CARD (PtypePL)	Y	
-			B59-1104-00	SERVICE DIRECTORY	P	
-		*	B60-4593-00	INSTRUCTION MANUAL (EN)		
-		*	B60-4596-00	INSTRUCTION MANUAL (FR)	P	
-		*	B60-4611-00	INSTRUCTION MANUAL EN(R)		
-		*	B60-4614-00	INSTRUCTION MANUAL FR(R)	P	
△ 621	1C	*	E30-2605-05	AC POWER CORD	Y	
△ 621	1C	*	E30-2941-05	AC POWER CORD	KP	
622	1C,2B	*	E35-2456-05	FLAT CABLE (33P)		
623	1C	*	E35-2480-05	FLAT CABLE (23P)		
624	1C,2B	*	E35-2613-05	FLAT CABLE (21P)		
-			G11-2416-04	CUSHION		
-		*	H10-7628-02	POLYSTYRENE FOAMED FIXTURE		
-		*	H10-7629-02	POLYSTYRENE FOAMED FIXTURE		
-			H25-0232-04	PROTECTION BAG (235X350X0.03)		
-			H25-0391-04	PROTECTION BAG		
-		*	H50-3598-04	ITEM CARTON CASE	KP	
-		*	H50-3599-04	ITEM CARTON CASE	Y	
636	2C	*	J02-1464-03	FOOT		
637	2C	*	J19-2808-05	HOLDER		
638	2B,2C	*	J19-3752-14	UNIT HOLDER		
639	1C	*	J19-6078-05	UNIT HOLDER		
△ 643	1C	*	J42-0083-05	POWER CORD BUSHING		
-			J61-0307-05	WIRE BAND		
650	2A	*	K27-2384-04	KNOB (BUTTON)	Y	
651	2B	*	K29-7675-12	KNOB		
652	2A	*	K29-7678-04	KNOB (VOLUME)		
653	1A,2A	*	K29-7681-14	KNOB (MULTI/INPUT)		
654	2A	*	K29-7687-03	KNOB (POWER/SPEAKER)		

L : Scandinavia K : USA P : Canada R : Mexico C : China I : Malaysia  
Y : PX(Far East,Hawaii) T : England E : Europe G : Germany V : China(Shanghai)  
Y : AAFES(Europe) X : Australia Q : Russia H : Korea M : Other Areas △ indicates safety critical components .

\* New Parts  
Parts without **Parts No.** are not supplied.  
Les articles non mentionnés dans le **Parts No.** ne sont pas fournis.  
Teile ohne **Parts No.** werden nicht geliefert.

④

Ref. No	Add-ress	New Parts	Parts No.	Description	Desti-nation	Re-marks
△ 660	2B	*	L07-2787-05	POWER TRANSFORMER	KP	
△ 660	2B	*	L07-2788-05	POWER TRANSFORMER	Y	
670	1A	*	T90-0836-05	LEAD WIRE ANTENNA		
671	1A	*	T90-0852-05	LOOP ANTENNA		
<b>VR-407/407-S/KRF-V7030D/V7030D-S</b>						
601	1A	*	A01-3733-01	METALLIC CABINET	KPY	
601	1A	*	A01-3734-01	METALLIC CABINET	MIXK1	
602	1A	*	A09-1178-08	BATTERY COVER		
604	2B	*	A46-0309-04	REAR COVER		
605	1A,2A	*	A60-1736-11	PANEL	KP	
605	1A,2A	*	A60-1737-11	PANEL	Y	
605	1A,2A	*	A60-1738-11	PANEL	K1	
605	1A,2A	*	A60-1739-11	PANEL	MIX	
606	1A	*	A70-1330-05	REMOTE CONTROL ASSY(RC-R0609)		
610	2A	*	B07-2476-02	ESCUTCHEON	MIXK1	
610	2A	*	B07-2507-02	ESCUTCHEON	KPY	
611	2A	*	B10-3546-02	FRONT GLASS	KPK11	
611	2A	*	B10-3547-02	FRONT GLASS	YMIX	
612	1A,2B	*	B12-0383-04	INDICATOR		
613	1A,2B	*	B12-0385-04	INDICATOR		
614	1A,2A		B43-0314-04	KENWOOD BADGE		
-			B46-0096-53	WARRANTY CARD	X	
-			B46-0328-03	WARRANTY CARD	KYK1	
-			B46-0346-00	QUESTIONNAIRE CARD	KK1	
-			B46-0347-03	WARRANTY CARD	Y	
-			B58-0513-04	CAUTION CARD (PRESET220-240)	Y	
-			B58-0964-13	CAUTION CARD (UL)	KYK1	
-			B58-0966-13	CAUTION CARD (T,XtypePL)	X	
-			B58-0966-13	CAUTION CARD (ELMtypePL)	MI	
-		*	B58-0967-03	CAUTION CARD (PtypePL)	P	
-			B59-1104-00	SERVICE DIRECTORY	Y	
-		*	B60-4598-00	INSTRUCTION MANUAL (EN)		
-		*	B60-4599-00	INSTRUCTION MANUAL (FR)	P	
-		*	B60-4600-00	INSTRUCTION MANUAL (TC)	MI	
-		*	B60-4603-00	INSTRUCTION MANUAL (ES)	M	
-		*	B60-4617-00	INSTRUCTION MANUAL EN(R)		
-		*	B60-4618-00	INSTRUCTION MANUAL FR(R)	P	
-		*	B60-4619-00	INSTRUCTION MANUAL ES(R)	M	
-		*	B60-4620-00	INSTRUCTION MANUAL TC(R)	MI	
△ 620	1A	*	E03-0115-05	AC PLUG ADAPTER	M	
△ 621	1C	*	E30-2605-05	AC POWER CORD	Y	
△ 621	1C	*	E30-2717-05	AC POWER CORD	X	
△ 621	1C	*	E30-2941-05	AC POWER CORD	KPK1	
△ 621	1C	*	E30-2942-05	AC POWER CORD	MI	
622	1C,2B	*	E35-2456-05	FLAT CABLE (33P)		
623	1C	*	E35-2480-05	FLAT CABLE (23P)		
624	1C,2B	*	E35-2613-05	FLAT CABLE (21P)		
-			G11-2416-04	CUSHION		
-		*	H10-7628-02	POLYSTYRENE FOAMED FIXTURE		
-		*	H10-7629-02	POLYSTYRENE FOAMED FIXTURE		
-			H25-0232-04	PROTECTION BAG (235X350X0.03)		
-			H25-0391-04	PROTECTION BAG		
-		*	H50-3602-04	ITEM CARTON CASE	KP	

L : Scandinavia K : USA P : Canada R : Mexico C : China I : Malaysia  
Y : PX(Far East,Hawaii) T : England E : Europe G : Germany V : China(Shanghai)  
Y : AAFES(Europe) X : Australia Q : Russia H : Korea M : Other Areas △ indicates safety critical components .

PARTS LIST

KRF-V7030D/V8030D/VR-407/409

\* New Parts  
 Parts without **Parts No.** are not supplied.  
 Les articles non mentionnés dans le **Parts No.** ne sont pas fournis.  
 Teile ohne **Parts No.** werden nicht geliefert.

5

Ref. No	Address	New Parts	Parts No.	Description	Destination	Remarks
-		*	H50-3603-04	ITEM CARTON CASE	K1	
-		*	H50-3604-04	ITEM CARTON CASE	Y	
-		*	H50-3605-04	ITEM CARTON CASE	X	
-		*	H50-3606-04	ITEM CARTON CASE	MI	
636	2C	*	J02-1464-03	FOOT		
637	2C		J19-2808-05	HOLDER		
638	2B,2C		J19-3752-14	UNIT HOLDER		
639	1C	*	J19-6078-05	UNIT HOLDER		
643	1C		J42-0083-05	POWER CORD BUSHING		
-			J61-0307-05	WIRE BAND		
650	2A	*	K27-2384-04	KNOB (BUTTON)	Y	
650	2B	*	K27-2385-04	KNOB (BUTTON)	MIX	
651	2A	*	K29-7675-12	KNOB	KPY	
651	1A,2A	*	K29-7676-12	KNOB	MIXK1	
652	2A	*	K29-7678-04	KNOB (VOLUME)	KPY	
652	2A	*	K29-7679-04	KNOB (VOLUME)	MIXK1	
653	1A,2A	*	K29-7681-14	KNOB (MULTI/INPUT)	KPY	
653	1A,2A	*	K29-7682-14	KNOB (MULTI/INPUT)	MIXK1	
654	2A	*	K29-7687-03	KNOB (POWER/SPEAKER)	KPY	
654	2A	*	K29-7688-03	KNOB (POWER/SPEAKER)	MIXK1	
660	2B	*	L07-2787-05	POWER TRANSFORMER	KPK1	
660	2B	*	L07-2788-05	POWER TRANSFORMER	YMI	
660	2B	*	L07-2789-05	POWER TRANSFORMER	X	
670	1A		T90-0836-05	LEAD WIRE ANTENNA		
671	1A	*	T90-0852-05	LOOP ANTENNA		
<b>POWER SUPPLY UNIT (X00-3000-20) Y,M,I,X only</b>						
CN1			E40-8386-05	PIN ASSY		
F3			F05-3121-05	FUSE (SEMKO) (250V T3.15AL)		
CN2 ,3			J13-0075-05	FUSE CLIP		
S1			S62.1.5	SLIDE SWITCH		
<b>POWER AMPLIFIER UNIT (X07-312X/313X-XX)</b>						
C1			CK73FB1H223K	CHIP C	0.022UF	K
C2			CK73FB1H103K	CHIP C	0.010UF	K
C3			CK73FB1H103K	CHIP C	0.010UF	K
C4			CC73FCH1H331J	CHIP C	330PF	J
C4			CC73FCH1H331J	CHIP C	330PF	J
C5 ,6			CK73FB1H103K	CHIP C	0.010UF	K
C7			CE04LW1C470M	ELECTRO	47UF	16WV
C8			CK73EB1H103K	CHIP C	0.010UF	K
C9			CC73FCH1H102J	CHIP C	1000PF	J
C10			CE04LW1C470M	ELECTRO	47UF	16WV
C11 ,12			CK73FB1H473K	CHIP C	0.047UF	K
C14			CE04LW1C100M	ELECTRO	10UF	16WV
C15			CE04LW1H010M	ELECTRO	1.0UF	50WV
C16			CE04RW1HR47M	ELECTRO	0.47UF	50WV
C17			CE04LW1H010M	ELECTRO	1.0UF	50WV
C18			CC73FCH1H470J	CHIP C	47PF	J
C19			CE04RW1A100M	ELECTRO	10UF	10WV
C20			CK73FB1H473K	CHIP C	0.047UF	K
C21			CE04RW1V3R3M	ELECTRO	3.3UF	35WV
C22			CK73FB1H473K	CHIP C	0.047UF	K

L : Scandinavia K : USA P : Canada R : Mexico C : China I : Malaysia  
 Y : PX(Far East,Hawaii) T : England E : Europe G : Germany V : China(Shanghai)  
 Y : AAFES(Europe) X : Australia Q : Russia H : Korea M : Other Areas  $\Delta$  indicates safety critical components.

40

\* New Parts  
 Parts without **Parts No.** are not supplied.  
 Les articles non mentionnés dans le **Parts No.** ne sont pas fournis.  
 Teile ohne **Parts No.** werden nicht geliefert.

6

Ref. No	Address	New Parts	Parts No.	Description	Destination	Remarks
C23			CE04LW1C100M	ELECTRO	10UF	16WV
C24			CK73FB1H331K	CHIP C	330PF	K
C25			CC73FCH1H181J	CHIP C	180PF	J
C25			CC73FCH1H471J	CHIP C	470PF	J
C26			CK73FB1H183K	CHIP C	0.018UF	K
C26			CK73FB1H223K	CHIP C	0.022UF	K
C27			CE04HW1E4R7M	NP-ELEC	4.7UF	25WV
C28 ,29			CE04LW1H2R2M	ELECTRO	2.2UF	50WV
C30 ,31			CK73FB1H223K	CHIP C	0.022UF	K
C30 ,31			CK73FB1H333K	CHIP C	0.033UF	K
C30 ,31			CK73FB1H333K	CHIP C	0.033UF	K
C32			CE04LW1V4R7M	ELECTRO	4.7UF	35WV
C33 ,34			CK73FB1H103K	CHIP C	0.010UF	K
C35			CK73FB1H332K	CHIP C	3300PF	K
C36			CK73FB1H103K	CHIP C	0.010UF	K
C37 ,38			CE04LW1C100M	ELECTRO	10UF	16WV
C41			CC73FCH1H470J	CHIP C	47PF	J
C42			CC73FCH1H120J	CHIP C	12PF	J
C43			CC73FCH1H100D	CHIP C	10PF	D
C44			CK73FB1H471K	CHIP C	470PF	K
C45			CC73FCH1H220J	CHIP C	22PF	J
C46			CE04LW1C100M	ELECTRO	10UF	16WV
C47			CK73FB1H102K	CHIP C	1000PF	K
C48			CE04LW1C470M	ELECTRO	47UF	16WV
C49			CE04LW1H2R2M	ELECTRO	2.2UF	50WV
C50			CC73FCH1H101J	CHIP C	100PF	J
C51			CK73FB1H471K	CHIP C	470PF	K
C52			CC73FCH1H101J	CHIP C	100PF	J
C70 ,71			CK73FB1H682K	CHIP C	6800PF	K
C72			CE04LW1H010M	ELECTRO	1.0UF	50WV
C73			CE04LW1C470M	ELECTRO	47UF	16WV
C74			CK73FB1H102K	CHIP C	1000PF	K
C75			CC73FCH1H030C	CHIP C	3.0PF	C
C76			CC73FCH1H470J	CHIP C	47PF	J
C77			CC73FCH1H101J	CHIP C	100PF	J
C78			CK73FB1H223K	CHIP C	0.022UF	K
C79 ,80			CK73FB1H472K	CHIP C	4700PF	K
C81			CK73FF1C105Z	CHIP C	1.0UF	Z
C82			CK73FB1H103K	CHIP C	0.010UF	K
C82			CK73FB1H103K	CHIP C	0.010UF	K
C83			CC73FCH1H101J	CHIP C	100PF	J
C84 ,85			CK73FB1H223K	CHIP C	0.022UF	K
C86			CK73FB1H471K	CHIP C	470PF	K
C88			CK73FB1H332K	CHIP C	3300PF	K
C89 ,90			CK73FB1H472K	CHIP C	4700PF	K
C91			CK73FF1C105Z	CHIP C	1.0UF	Z
C101,102			CC73FCH1H390J	CHIP C	39PF	J
C103,104		*	CE04RW1V100M	ELECTRO	10UF	35WV
C105,106			CC73FCH1H221J	CHIP C	220PF	J
C107,108			CE04RW0J470M	ELECTRO	47UF	6.3WV
C109,110			CC73FCH1H471J	CHIP C	470PF	J
C111,112			Q93FMG1H123J	MYLAR	0.012UF	J
C113,114			CK45FB1H332K	CERAMIC	3300PF	K
C115,116			CE04LW1V4R7M	ELECTRO	4.7UF	35WV
C117,118			CC45FCH1H101J	CERAMIC	100PF	J

L : Scandinavia K : USA P : Canada R : Mexico C : China I : Malaysia  
 Y : PX(Far East,Hawaii) T : England E : Europe G : Germany V : China(Shanghai)  
 Y : AAFES(Europe) X : Australia Q : Russia H : Korea M : Other Areas  $\Delta$  indicates safety critical components.

KRF-V7030D/V8030D/VR-407/409

PARTS LIST

\* New Parts  
Parts without **Parts No.** are not supplied.  
Les articles non mentionnés dans le **Parts No.** ne sont pas fournis.  
Teile ohne **Parts No.** werden nicht geliefert.

7

Ref. No	Add-ress	New Parts	Parts No.	Description	Desti-nation	Re-marks
C119-136			CC73FCH1H221J	CHIP C		
C137,138			CE04LW1H2R2M	ELECTRO		
C139,140			CC73FCH1H101J	CHIP C		
C141,142			CE04LW1H2R2M	ELECTRO		
C143,144			CC73FCH1H101J	CHIP C		
C145,146			CE04LW1C220M	ELECTRO		
C147,148			CC73FCH1H471J	CHIP C		
C149,150			CE04LW1E470M	ELECTRO		
C151,152			CC73FCH1H100D	CHIP C		
C153,154			CE04KW1H100M	ELECTRO		
C155,156			CE04KW1H2R2M	ELECTRO		
C157,158			CC73FCH1H102J	CHIP C		
C159,160			CK73FB1H222K	CHIP C		
C161,162			CC73FCH1H220J	CHIP C		
C163,164			CC73FCH1H102J	CHIP C		
C165,166			CE04KW1A101M	ELECTRO		
C167-170			CK73FF1E104Z	CHIP C		
C171,172			CQ93FMG1H472J	MYLAR		
C173,174			CC73FCH1H221J	CHIP C	E	3
C173,174			CC73FCH1H221J	CHIP C	MIX	8
C173,174			CC73FCH1H221J	CHIP C	Y	9
C175,176			CC73FCH1H471J	CHIP C		
C177,178			CE04LW1E470M	ELECTRO		
C179,180			CC73FCH1H100D	CHIP C		
C181,182			CE04KW1H100M	ELECTRO		
C183,184			CE04KW1H2R2M	ELECTRO		
C185,186			CC73FCH1H102J	CHIP C		
C187,188			CK73FB1H222K	CHIP C		
C189,190			CC45FCH1H220J	CERAMIC		
C191,192			CC73FCH1H102J	CHIP C		
C193,194			CE04KW1A101M	ELECTRO		
C195-198			CK73FF1E104Z	CHIP C		
C199-202			CQ93FMG1H472J	MYLAR		
C203,204			CC73FCH1H221J	CHIP C	E	3
C203,204			CC73FCH1H221J	CHIP C	MIX	8
C203,204			CC73FCH1H221J	CHIP C	Y	9
C205			CC73FCH1H471J	CHIP C		
C206			CE04LW1E470M	ELECTRO		
C207			CC73FCH1H100D	CHIP C		
C208			CE04KW1H100M	ELECTRO		
C209			CE04KW1H2R2M	ELECTRO		
C210			CC73FCH1H102J	CHIP C		
C211			CK73FB1H222K	CHIP C		
C212			CC45FCH1H220J	CERAMIC		
C213			CC73FCH1H102J	CHIP C		
C214			CE04KW1A101M	ELECTRO		
C215,216			CK73FF1E104Z	CHIP C		
C217			CQ93FMG1H472J	MYLAR		
C218			CC73FCH1H221J	CHIP C	E	3
C218			CC73FCH1H221J	CHIP C	MIX	8
C218			CC73FCH1H221J	CHIP C	Y	9
C220			CC73FCH1H471J	CHIP C		
C221			CE04LW1A101M	ELECTRO		
C222			CC73FCH1H101J	CHIP C		
C223			CE04LW1H100M	ELECTRO		

L : Scandinavia K : USA P : Canada R : Mexico C : China I : Malaysia  
Y : PX(Far East,Hawaii) T : England E : Europe G : Germany V : China(Shanghai)  
Y : AAFES(Europe) X : Australia Q : Russia H : Korea M : Other Areas  $\Delta$  indicates safety critical components.

\* New Parts  
Parts without **Parts No.** are not supplied.  
Les articles non mentionnés dans le **Parts No.** ne sont pas fournis.  
Teile ohne **Parts No.** werden nicht geliefert.

8

Ref. No	Add-ress	New Parts	Parts No.	Description	Desti-nation	Re-marks
C224			CC73FCH1H221J	CHIP C		
C225,226			CK45FF1H103Z	CERAMIC		
C227-230			CC73FCH1H101J	CHIP C		
C231,232		*	C90-3916-05	ELECTRO		75WV
C231,232		*	C90-3918-05	ELECTRO		63WV
C233,234		*	C90-3917-05	ELECTRO		3300UF
C233,234		*	C90-3919-05	ELECTRO		3300UF
C235			CE04KW1E222M	ELECTRO		2200UF
C236			CE04KW1E471M	ELECTRO		470UF
C237,238			CE04LW1C101M	ELECTRO		100UF
C239			CE04LW1H220M	ELECTRO		22UF
C240			CE04LW1V470M	ELECTRO		47UF
C241			CC45FCH1H101J	CERAMIC		100PF
C242			CK45FF1H103Z	CERAMIC		0.010UF
C245			CC73FCH1H221J	CHIP C		220PF
C246			CK45FF1H103Z	CERAMIC		0.010UF
C247			CC73FCH1H101J	CHIP C		100PF
C248			CC73FCH1H221J	CHIP C		220PF
C250			CC73FCH1H102J	CHIP C		1000PF
C251,252			CE04KW2A100M	ELECTRO		10UF
C253,254			CE04KW2A101M	ELECTRO		100UF
C255,256			CE04DW1J101M	ELECTRO		100UF
C259			CE04LW1A101M	ELECTRO		100UF
C260			CE04LW0J221M	ELECTRO		220UF
C261			CE04LW1V4R7M	ELECTRO		4.7UF
C262			CE04LW0J221M	ELECTRO		220UF
C263			CE04LW1V4R7M	ELECTRO		4.7UF
C264			CE04LW1H010M	ELECTRO		1.0UF
C265-267			CC73FCH1H102J	CHIP C		1000PF
C268			CK73FF1C105Z	CHIP C		1.0UF
C415			CE04LW1H010M	ELECTRO		1.0UF
C416,417			CE04HW1E100M	NP-ELEC		10UF
C601			CE04LW1E332M	ELECTRO		3300UF
C602			CE04LW1H100M	ELECTRO		10UF
C603			CK45FF1H103Z	CERAMIC		0.010UF
C604			CE04LW1H100M	ELECTRO		10UF
C605			CE04LW0J222M	ELECTRO		2200UF
C606			CK73FB1E104K	CHIP C		0.10UF
C606			CK73FB1E104K	CHIP C		0.10UF
C606			CK73FB1H683K	CHIP C		0.068UF
CN1			E40-8364-05	PIN ASSY		
CN2			E40-8197-05	SOCKET FOR PIN ASSY		
CN3		*	E40-8485-05	FLAT CABLE CONNECTOR		
CN4			E40-4871-05	PIN ASSY		
CN4			E40-4871-05	PIN ASSY		
CN5			E40-9831-05	SOCKET FOR PIN ASSY		
CN6			E40-9848-05	PIN ASSY		
CN7		*	E40-8490-05	FLAT CABLE CONNECTOR		
CN61			E40-4245-05	PIN ASSY		
CN62			E40-4245-05	PIN ASSY		
CN62			E40-4245-05	PIN ASSY		
CN63			E40-4428-05	PIN ASSY		
CN64			E40-4245-05	PIN ASSY		
CN64			E40-4245-05	PIN ASSY		
CN64			E40-4245-05	PIN ASSY		
CN65			E40-8196-05	PIN ASSY		

L : Scandinavia K : USA P : Canada R : Mexico C : China I : Malaysia  
Y : PX(Far East,Hawaii) T : England E : Europe G : Germany V : China(Shanghai)  
Y : AAFES(Europe) X : Australia Q : Russia H : Korea M : Other Areas  $\Delta$  indicates safety critical components.

KRF-V7030D/V8030D/VR-407/409  
PARTS LIST

\* New Parts  
Parts without **Parts No.** are not supplied.  
Les articles non mentionnés dans le **Parts No.** ne sont pas fournis.  
Teile ohne **Parts No.** werden nicht geliefert.

9

Ref. No	Add-ress	New Parts	Parts No.	Description	Desti-nation	Re-marks
J1			E70-0049-05	SCREW TERMINAL BOARD		
J2			E70-0065-05	LOCK TERMINAL BOARD		
J3 ,4		*	E63-1143-05	PIN JACK		
J5		*	E63-1144-05	PIN JACK		
J6		*	E63-1145-05	PIN JACK (6P)	YMIXE	
J7		*	E63-1146-05	PIN JACK (1P)	EE1T	
J7		*	E63-1146-05	PIN JACK	KP	9
J7		*	E63-1146-05	PIN JACK		7
J8			E20-0321-05	LOCK TERMINAL BOARD(2P,F)		
J8			E70-0052-05	LOCK TERMINAL BOARD		
Δ J61			E03-0148-05	AC OUTLET	KPK1Y	
Δ J61			E03-0149-05	AC OUTLET	EE1MI	
Δ J61			E03-0310-05	AC OUTLET	T	
Δ J61			E03-0325-05	AC OUTLET	X	
E1			F10-1129-14	SHIELDING PLATE		789
E1		*	F10-1167-04	SHIELDING PLATE	EE1T	
Δ F1			F05-3121-05	FUSE (SEMKO) (250V T3.15AL)	EE1T	
Δ F1			F05-3121-05	FUSE (SEMKO) (250V T3.15AL)	YMIX	
Δ F1			F50-0077-05	FUSE(5X20)	KPK1	
Δ F2			F05-2525-05	FUSE (SEMKO) (250V T2.5AL)	EE1	
Δ CN66,67			J13-0075-05	FUSE CLIP	EE1	
Δ CN68,69			J13-0075-05	FUSE CLIP	EE1	
CF1 ,2			L72-0531-05	CERAMIC FILTER	YMIX	
CF1 ,2			L72-0536-05	CERAMIC FILTER	EE1T	
CF1 ,2			L72-0596-05	CERAMIC FILTER	KPK1	
CF3			L72-0607-05	CERAMIC FILTER	YMIX	
L1		*	L39-1384-05	COMBINATION COIL		
L2			L40-1091-82	SMALL FIXED INDUCTOR(1.0UH)		
L3			L30-0911-05	AM IFT		
L4			L30-0933-05	FM IFT	KPK1	
L4			L30-0950-05	FM IFT	EE1T	
L5			L30-0951-05	FM IFT	EE1T	
L6 ,7			L79-1236-05	LC FILTER	EE1T	
L8			L40-1001-17	SMALL FIXED INDUCTOR(10UH,K)	EE1T	
L101-105			L39-1373-05	PHASE COMPENSATION COIL		
Δ T1			L07-2758-05	POWER TRANSFORMER	EE1T	
Δ T1			L07-2758-05	POWER TRANSFORMER	KPK1X	
Δ T1			L07-2761-05	POWER TRANSFORMER	EE1T	
Δ T1			L07-2761-05	POWER TRANSFORMER	KPK1X	
Δ T1		*	L07-2805-05	POWER TRANSFORMER	YMI	
X1			L77-2232-05	CRYSTAL RESONATOR		
R1			RK73FB2A101J	CHIP R 100 J 1/10W		
R4			RK73FB2A681J	CHIP R 680 J 1/10W		
R5			RK73FB2A332J	CHIP R 3.3K J 1/10W		
R6			RK73FB2A221J	CHIP R 220 J 1/10W		
R7			RK73FB2A821J	CHIP R 820 J 1/10W		
R8			RK73FB2A100J	CHIP R 10 J 1/10W	EE1T	
R8			RK73FB2A330J	CHIP R 33 J 1/10W		789
R9			RK73FB2A391J	CHIP R 390 J 1/10W		
R10			RK73FB2A102J	CHIP R 1.0K J 1/10W		
R11			RK73FB2A220J	CHIP R 22 J 1/10W	EE1T	

L : Scandinavia K : USA P : Canada R : Mexico C : China I : Malaysia  
Y : PX(Far East,Hawaii) T : England E : Europe G : Germany V : China(Shanghai)  
Y : AAFES(Europe) X : Australia Q : Russia H : Korea M : Other Areas Δ indicates safety critical components.

\* New Parts  
Parts without **Parts No.** are not supplied.  
Les articles non mentionnés dans le **Parts No.** ne sont pas fournis.  
Teile ohne **Parts No.** werden nicht geliefert.

10

Ref. No	Add-ress	New Parts	Parts No.	Description	Desti-nation	Re-marks
R11			RK73FB2A330J	CHIP R 33 J 1/10W		789
R12			RK73FB2A101J	CHIP R 100 J 1/10W		
R14			RK73FB2A101J	CHIP R 100 J 1/10W	EE1T	
R14			RK73FB2A101J	CHIP R 100 J 1/10W	KPK1	
R14			RK73FB2A271J	CHIP R 270 J 1/10W	YMIX	
R15			RK73FB2A333J	CHIP R 33K J 1/10W	EE1T	
R15			RK73FB2A472J	CHIP R 4.7K J 1/10W	KPK1	
R16			RK73FB2A220J	CHIP R 22 J 1/10W		
R17			RK73FB2A362J	CHIP R 3.6K J 1/10W		
R18			RK73FB2A302J	CHIP R 3.0K J 1/10W		
R19			RK73FB2A822J	CHIP R 8.2K J 1/10W		
R20			RK73FB2A392J	CHIP R 3.9K J 1/10W		
R23			RK73FB2A153J	CHIP R 15K J 1/10W	EE1T	
R23			RK73FB2A332J	CHIP R 3.3K J 1/10W	YMIX	
R23			RK73FB2A912J	CHIP R 9.1K J 1/10W	KPK1	
R25			RK73FB2A163J	CHIP R 16K J 1/10W	KPK1	
R25			RK73FB2A183J	CHIP R 18K J 1/10W	YMIX	
R25			RK73FB2A273J	CHIP R 27K J 1/10W	EE1T	
R27 ,28			RK73FB2A432J	CHIP R 4.3K J 1/10W	EE1T	
R27 ,28			RK73FB2A682J	CHIP R 6.8K J 1/10W	KPK1	
R27 ,28			RK73FB2A752J	CHIP R 7.5K J 1/10W	YMIX	
R29			RK73FB2A101J	CHIP R 100 J 1/10W	YMI	
R30			RK73FB2A561J	CHIP R 560 J 1/10W	YMI	
R31			RK73FB2A473J	CHIP R 47K J 1/10W	YMI	
R32			RK73FB2A272J	CHIP R 2.7K J 1/10W		789
R33 ,34			RK73FB2A102J	CHIP R 1.0K J 1/10W		
R35			RK73FB2A101J	CHIP R 100 J 1/10W	EE1T	
R36			RK73FB2A102J	CHIP R 1.0K J 1/10W	EE1T	
R37			RK73FB2A392J	CHIP R 3.9K J 1/10W	EE1T	
R38			RK73FB2A102J	CHIP R 1.0K J 1/10W	EE1T	
R39			RK73FB2A103J	CHIP R 10K J 1/10W	EE1T	
R42			RK73FB2A103J	CHIP R 10K J 1/10W		
R43			RK73FB2A221J	CHIP R 220 J 1/10W		
Δ R44			RD14NB2E271J	RD 270 J 1/4W		
R45			RK73EB2B102J	CHIP R 1.0K J 1/8W		
R46			RK73FB2A102J	CHIP R 1.0K J 1/10W		
R47			RK73EB2B102J	CHIP R 1.0K J 1/8W		
R48			RK73FB2A102J	CHIP R 1.0K J 1/10W		
R49			RK73FB2A103J	CHIP R 10K J 1/10W		
Δ R50			RD14NB2E471J	RD 470 J 1/4W		
R51			RK73FB2A562J	CHIP R 5.6K J 1/10W		
R52			RK73FB2A101J	CHIP R 100 J 1/10W		
R53			RK73FB2A222J	CHIP R 2.2K J 1/10W		
R54			RK73FB2A102J	CHIP R 1.0K J 1/10W		
R55			RK73FB2A333J	CHIP R 33K J 1/10W		
R56 ,57			RK73FB2A102J	CHIP R 1.0K J 1/10W		
R58			RK73FB2A123J	CHIP R 12K J 1/10W		
R59			RK73FB2A122J	CHIP R 1.2K J 1/10W		
R72 ,73			RK73FB2A153J	CHIP R 15K J 1/10W	KPK1	
R72 ,73			RK73FB2A392J	CHIP R 3.9K J 1/10W	EE1T	
R72 ,73			RK73FB2A822J	CHIP R 8.2K J 1/10W	YMIX	
R74			RK73FB2A473J	CHIP R 47K J 1/10W		
R75			RK73FB2A822J	CHIP R 8.2K J 1/10W		
R76			RK73FB2A182J	CHIP R 1.8K J 1/10W		
R78			RK73FB2A821J	CHIP R 820 J 1/10W		

L : Scandinavia K : USA P : Canada R : Mexico C : China I : Malaysia  
Y : PX(Far East,Hawaii) T : England E : Europe G : Germany V : China(Shanghai)  
Y : AAFES(Europe) X : Australia Q : Russia H : Korea M : Other Areas Δ indicates safety critical components.

\* New Parts  
 Parts without **Parts No.** are not supplied.  
 Les articles non mentionnés dans le **Parts No.** ne sont pas fournis.  
 Teile ohne **Parts No.** werden nicht geliefert.



Ref. No	Add-ress	New Parts	Parts No.	Description	Desti-nation	Re-marks
R79			RK73FB2A102J	CHIP R 1.0K J 1/10W		
R80			RK73FB2A223J	CHIP R 22K J 1/10W	EE1T	
R81			RS14KB3A820J	FL-PROOF RS 82 J 1W		
R82			RK73FB2A272J	CHIP R 2.7K J 1/10W	EE1T	
R83			RK73FB2A102J	CHIP R 1.0K J 1/10W		
R84			RK73EB2B102J	CHIP R 1.0K J 1/8W		
R85-87			RK73FB2A105J	CHIP R 1.0M J 1/10W		
R88			RK73FB2A563J	CHIP R 56K J 1/10W		
R89			RK73FB2A333J	CHIP R 33K J 1/10W		
R101,102			RK73FB2A102J	CHIP R 1.0K J 1/10W		
R103,104			RK73FB2A273J	CHIP R 27K J 1/10W		
R105,106			RK73FB2A101J	CHIP R 100 J 1/10W		
R117,118			RK73FB2A102J	CHIP R 1.0K J 1/10W		
R119,120			RK73FB2A224J	CHIP R 220K J 1/10W		
R121,122			RK73FB2A102J	CHIP R 1.0K J 1/10W		
R123,124			RK73FB2A224J	CHIP R 220K J 1/10W		
R125,126			RK73FB2A102J	CHIP R 1.0K J 1/10W		
R127,128			RK73FB2A224J	CHIP R 220K J 1/10W		
R129,130			RK73FB2A102J	CHIP R 1.0K J 1/10W		
R131,132			RK73FB2A224J	CHIP R 220K J 1/10W		
R133,134			RK73FB2A102J	CHIP R 1.0K J 1/10W		
R135,136			RK73FB2A224J	CHIP R 220K J 1/10W		
R137,138			RK73FB2A102J	CHIP R 1.0K J 1/10W		
R139,140			RK73FB2A224J	CHIP R 220K J 1/10W		
R141,142			RK73FB2A102J	CHIP R 1.0K J 1/10W		
R143,144			RK73FB2A224J	CHIP R 220K J 1/10W		
R145,146			RK73FB2A102J	CHIP R 1.0K J 1/10W		
R147,148			RK73FB2A224J	CHIP R 220K J 1/10W		
R149,150			RK73FB2A102J	CHIP R 1.0K J 1/10W		
R151-156			RK73FB2A224J	CHIP R 220K J 1/10W		
R159			RK73FB2A562J	CHIP R 5.6K J 1/10W		
R161,162			RK73FB2A302J	CHIP R 3.0K J 1/10W		
R163,164			RK73FB2A682J	CHIP R 6.8K J 1/10W		
R165,166			RK73FB2A183J	CHIP R 18K J 1/10W		
R167,168			RK73FB2A182J	CHIP R 1.8K J 1/10W		
R169,170			RK73FB2A224J	CHIP R 220K J 1/10W		
R171,172			RK73FB2A183J	CHIP R 18K J 1/10W		
R173,174			RK73FB2A222J	CHIP R 2.2K J 1/10W		
R175,176			RK73FB2A104J	CHIP R 100K J 1/10W		
R177,178			RK73FB2A563J	CHIP R 56K J 1/10W		
R179			RK73FB2A102J	CHIP R 1.0K J 1/10W		
R180			RK73EB2B102J	CHIP R 1.0K J 1/8W		
R181-184			RS14KB3DR22J	FL-PROOF RS 0.22 J 2W		
R185,186			RK73FB2A563J	CHIP R 56K J 1/10W		
R187,188			RK73FB2A182J	CHIP R 1.8K J 1/10W		789
R187,188			RK73FB2A242J	CHIP R 2.4K J 1/10W	EE1T	
R189,190			RS14KB3D120J	FL-PROOF RS 12 J 2W		
R191,192			RS14KB3D391J	FL-PROOF RS 390 J 2W		
R195,196			RK73FB2A104J	CHIP R 100K J 1/10W	E	3
R195,196			RK73FB2A104J	CHIP R 100K J 1/10W	MIX	8
R195,196			RK73FB2A104J	CHIP R 100K J 1/10W	Y	9
R197,198			RK73FB2A331J	CHIP R 330 J 1/10W	E	3
R197,198			RK73FB2A331J	CHIP R 330 J 1/10W	YMIX	
R199,200			RK73FB2A333J	CHIP R 33K J 1/10W		
R201,202			RK73FB2A303J	CHIP R 30K J 1/10W		

L : Scandinavia K : USA P : Canada R : Mexico C : China I : Malaysia  
 Y : PX(Far East,Hawaii) T : England E : Europe G : Germany V : China(Shanghai)  
 Y : AAFES(Europe) X : Australia Q : Russia H : Korea M : Other Areas  $\Delta$  indicates safety critical components.

\* New Parts  
 Parts without **Parts No.** are not supplied.  
 Les articles non mentionnés dans le **Parts No.** ne sont pas fournis.  
 Teile ohne **Parts No.** werden nicht geliefert.



Ref. No	Add-ress	New Parts	Parts No.	Description	Desti-nation	Re-marks
R203,204			RK73FB2A912J	CHIP R 9.1K J 1/10W		
R205,206			RK73FB2A471J	CHIP R 470 J 1/10W		
R209,210			RK73FB2A102J	CHIP R 1.0K J 1/10W		
R211,212			RK73FB2A273J	CHIP R 27K J 1/10W		
R213,214			RK73FB2A182J	CHIP R 1.8K J 1/10W		
R215,216			RK73FB2A224J	CHIP R 220K J 1/10W		
R217,218			RK73FB2A183J	CHIP R 18K J 1/10W		
R219,220			RK73EB2B222J	CHIP R 2.2K J 1/8W		
R221,222			RK73FB2A104J	CHIP R 100K J 1/10W		
R223,224			RK73FB2A563J	CHIP R 56K J 1/10W		
R225			RK73FB2A102J	CHIP R 1.0K J 1/10W		
R227-230			RS14KB3DR22J	FL-PROOF RS 0.22 J 2W		
R233,234			RK73FB2A182J	CHIP R 1.8K J 1/10W	EE1T	789
R233,234			RK73FB2A242J	CHIP R 2.4K J 1/10W		
R235,236			RS14KB3D120J	FL-PROOF RS 12 J 2W		
R239,240			RK73FB2A104J	CHIP R 100K J 1/10W	E	3
R239,240			RK73FB2A104J	CHIP R 100K J 1/10W	MIX	8
R239,240			RK73FB2A104J	CHIP R 100K J 1/10W	Y	9
R241,242			RK73FB2A331J	CHIP R 330 J 1/10W	E	3
R241,242			RK73FB2A331J	CHIP R 330 J 1/10W	MIX	8
R241,242			RK73FB2A331J	CHIP R 330 J 1/10W	Y	9
R243,244			RK73FB2A333J	CHIP R 33K J 1/10W		
R245,246			RK73FB2A303J	CHIP R 30K J 1/10W		
R247,248			RK73FB2A912J	CHIP R 9.1K J 1/10W		
R249,250			RK73FB2A471J	CHIP R 470 J 1/10W		
R251			RK73FB2A183J	CHIP R 18K J 1/10W		
R252			RK73FB2A182J	CHIP R 1.8K J 1/10W		
R253			RK73FB2A224J	CHIP R 220K J 1/10W		
R254			RK73FB2A183J	CHIP R 18K J 1/10W		
R256			RK73FB2A104J	CHIP R 100K J 1/10W		
R257			RK73FB2A563J	CHIP R 56K J 1/10W		
R259,260			RS14KB3DR22J	FL-PROOF RS 0.22 J 2W		
R262			RK73FB2A182J	CHIP R 1.8K J 1/10W	EE1T	789
R262			RK73FB2A242J	CHIP R 2.4K J 1/10W		
R263			RS14KB3D120J	FL-PROOF RS 12 J 2W		
R265			RK73FB2A104J	CHIP R 100K J 1/10W	E	3
R265			RK73FB2A104J	CHIP R 100K J 1/10W	MIX	8
R265			RK73FB2A104J	CHIP R 100K J 1/10W	Y	9
R266			RK73FB2A331J	CHIP R 330 J 1/10W	E	3
R266			RK73FB2A331J	CHIP R 330 J 1/10W	MIX	8
R266			RK73FB2A331J	CHIP R 330 J 1/10W	Y	9
R266			RK73FB2A303J	CHIP R 30K J 1/10W		
R268			RK73FB2A912J	CHIP R 9.1K J 1/10W		
R269			RK73FB2A471J	CHIP R 470 J 1/10W		
R270			RK73FB2A333J	CHIP R 33K J 1/10W		
R271			RK73FB2A183J	CHIP R 18K J 1/10W		
R272			RK73FB2A241J	CHIP R 240 J 1/10W		
R273			RK73FB2A332J	CHIP R 3.3K J 1/10W		
R274			RK73FB2A183J	CHIP R 18K J 1/10W		
R276			RK73FB2A224J	CHIP R 220K J 1/10W		
R277			RK73FB2A331J	CHIP R 330 J 1/10W		
R278			RK73FB2A102J	CHIP R 1.0K J 1/10W		
R279,280		*	R92-1956-05	METAL GLAZE 33K J 1/4W		
R281		*	R92-1945-05	METAL GLAZE 1 J 1/4W		
R283			RK73FB2A1R0J	CHIP R 1 J 1/10W		



L : Scandinavia K : USA P : Canada R : Mexico C : China I : Malaysia  
 Y : PX(Far East,Hawaii) T : England E : Europe G : Germany V : China(Shanghai)  
 Y : AAFES(Europe) X : Australia Q : Russia H : Korea M : Other Areas  $\Delta$  indicates safety critical components.

PARTS LIST

KRF-V7030D/V8030D/MR-407/409

\* New Parts  
Parts without **Parts No.** are not supplied.  
Les articles non mentionnés dans le **Parts No.** ne sont pas fournis.  
Teile ohne **Parts No.** werden nicht geliefert.

15

Ref. No	Add-ress	New Parts	Parts No.	Description	Desti-nation	Re-marks
Δ R284		*	RK73FB2A104J	CHIP R 100K	J	1/10W
R285			R92-1945-05	METAL GLAZE 1	J	1/4W
R287			RK73EB2B101J	CHIP R 100	J	1/8W
R301,302			RK73FB2A513J	CHIP R 51K	J	1/10W
R303-306			RS14KB3A392J	FL-PROOF RS 3.9K	J	1W
R307			RK73EB2B273J	CHIP R 27K	J	1/8W
R308			RK73FB2A273J	CHIP R 27K	J	1/10W
Δ R309,310			RK73FB2A1R0J	CHIP R 1	J	1/10W
R312			RD14NB2E103J	RD 10K	J	1/4W
R313,314			RK73FB2A473J	CHIP R 47K	J	1/10W
R315			RK73FB2A1R0J	CHIP R 1	J	1/10W
R316			RD14NB2E101J	RD 100	J	1/4W
R317			RD14BB2C752J	RD 7.5K	J	1/6W
R320			RK73FB2A103J	CHIP R 10K	J	1/10W
R323			RK73FB2A393J	CHIP R 39K	J	1/10W
R324,325			RK73FB2A753J	CHIP R 75K	J	1/10W
R326-328			RK73FB2A473J	CHIP R 47K	J	1/10W
R329			RK73FB2A123J	CHIP R 12K	J	1/10W
R330			RK73FB2A153J	CHIP R 15K	J	1/10W
R331			RK73FB2A332J	CHIP R 3.3K	J	1/10W
R332			RK73FB2A682J	CHIP R 6.8K	J	1/10W
R333			RK73FB2A223J	CHIP R 22K	J	1/10W
R334			RK73FB2A123J	CHIP R 12K	J	1/10W
R335			RK73FB2A153J	CHIP R 15K	J	1/10W
R336			RK73FB2A332J	CHIP R 3.3K	J	1/10W
R337			RK73FB2A682J	CHIP R 6.8K	J	1/10W
Δ R339,340		*	RK73FB2A472J	CHIP R 4.7K	J	1/10W
R341			R92-1945-05	METAL GLAZE 1	J	1/4W
R342-344			RS14KB3A151J	FL-PROOF RS 150	J	1W
R347			RS14KB3D4R7J	FL-PROOF RS 4.7	J	2W
R349			RS14KB3A4R7J	FL-PROOF RS 4.7	J	1W
Δ R350			RK73FB2A1R0J	CHIP R 1	J	1/10W
R351			RK73FB2A103J	CHIP R 10K	J	1/10W
R352			RK73FB2A223J	CHIP R 22K	J	1/10W
R353			RK73FB2A102J	CHIP R 1.0K	J	1/10W
R356-358			RK73FB2A103J	CHIP R 10K	J	1/10W
R360			RK73FB2A103J	CHIP R 10K	J	1/10W
R361,362			RK73FB2A473J	CHIP R 47K	J	1/10W
R363			RK73FB2A361J	CHIP R 360	J	1/10W
R365-369			RK73FB2A102J	CHIP R 1.0K	J	1/10W
R365-369			RK73FB2A102J	CHIP R 1.0K	J	1/10W
R365-369			RK73FB2A102J	CHIP R 1.0K	J	1/10W
R370			RK73FB2A102J	CHIP R 1.0K	J	1/10W
R371			RK73FB2A563J	CHIP R 56K	J	1/10W
R372			RK73FB2A104J	CHIP R 100K	J	1/10W
R373			RK73FB2A361J	CHIP R 360	J	1/10W
R375			RK73FB2A102J	CHIP R 1.0K	J	1/10W
R377,378			RK73FB2A102J	CHIP R 1.0K	J	1/10W
R384			RK73EB2B102J	CHIP R 1.0K	J	1/8W
R387,388			RK73FB2A473J	CHIP R 47K	J	1/10W
R389			RK73FB2A472J	CHIP R 4.7K	J	1/10W
R390			RK73FB2A473J	CHIP R 47K	J	1/10W
R391-394			RK73FB2A470J	CHIP R 47	J	1/10W
Δ R397-399			RD14NB2E1R0J	RD 1	J	1/4W
Δ R601			RD14NB2E1R0J	RD 1	J	1/4W

L : Scandinavia K : USA P : Canada R : Mexico C : China I : Malaysia  
Y : PX(Far East,Hawaii) T : England E : Europe G : Germany V : China(Shanghai)  
Y : AAFES(Europe) X : Australia Q : Russia H : Korea M : Other Areas Δ indicates safety critical components.

\* New Parts  
Parts without **Parts No.** are not supplied.  
Les articles non mentionnés dans le **Parts No.** ne sont pas fournis.  
Teile ohne **Parts No.** werden nicht geliefert.

17

Ref. No	Add-ress	New Parts	Parts No.	Description	Desti-nation	Re-marks
R604			RD14NB2E100J	RD 10	J	1/4W
R604			RD14NB2E390J	RD 39	J	1/4W
R604			RD14NB2E390J	RD 39	J	1/4W
R609			RD14NB2E151J	RD 150	J	1/4W
R609			RD14NB2E181J	RD 180	J	1/4W
R609			RD14NB2E2R2J	RD 2.2	J	1/4W
R609			RD14NB2E270J	RD 27	J	1/4W
Δ R610			R92-1844-05	CARBON 3.3M	J	1/2W
VR1			R32-0037-05	SEMI FIXED VARIABLE RESISTOR		
W108			R92-0670-05	CHIP R 0 OHM		
W301			R92-0679-05	CHIP R 0 OHM		
W302			R92-0670-05	CHIP R 0 OHM		
W303-306			R92-0679-05	CHIP R 0 OHM		
W307			R92-0670-05	CHIP R 0 OHM		
W308			R92-0679-05	CHIP R 0 OHM		
W309-311			R92-0670-05	CHIP R 0 OHM		
W312			R92-0679-05	CHIP R 0 OHM		
W313			R92-0670-05	CHIP R 0 OHM		
W315-318			R92-0679-05	CHIP R 0 OHM		
W319,320			R92-0670-05	CHIP R 0 OHM		
W321			R92-0679-05	CHIP R 0 OHM		
W322,323			R92-0670-05	CHIP R 0 OHM		
W324-333			R92-0679-05	CHIP R 0 OHM		
W336			R92-0679-05	CHIP R 0 OHM		
W338,339			R92-0670-05	CHIP R 0 OHM		
W340,341			R92-0679-05	CHIP R 0 OHM		
W342,343			R92-0670-05	CHIP R 0 OHM		
W506			R92-0679-05	CHIP R 0 OHM		
W513,514			R92-0679-05	CHIP R 0 OHM		
W523			R92-0679-05	CHIP R 0 OHM		
W651-655			R92-0670-05	CHIP R 0 OHM		
W656			R92-0670-05	CHIP R 0 OHM		
W659			R92-0670-05	CHIP R 0 OHM		
W660			R92-0670-05	CHIP R 0 OHM		
W662			R92-0670-05	CHIP R 0 OHM		
W680			R92-0679-05	CHIP R 0 OHM		
W682,683			R92-0679-05	CHIP R 0 OHM		
W684,685			R92-0679-05	CHIP R 0 OHM		
K1 -4			S76-0042-05	MAGNETIC RELAY		
K1 -4		*	S76-0097-05	MAGNETIC RELAY		
K1 -4		*	S76-0097-05	MAGNETIC RELAY		
Δ K601		*	S76-0099-05	MAGNETIC RELAY		
Δ K601		*	S76-0107-05	MAGNETIC RELAY		
Δ K601		*	S76-0107-05	MAGNETIC RELAY		
S1			S62-0034-05	MAGNETIC RELAY SLIDE SWITCH		
D1			UDZ3.3B	ZENER DIODE		
Δ D101			D5SBA20F03	DIODE		
Δ D102			S1ZB20(4101)	DIODE		
Δ D103			D5SBA20F03	DIODE		
Δ D103			RBV-602LFA	DIODE		
D104			HZS16N(B2)	ZENER DIODE		
D104			MTZJ16(B)	ZENER DIODE		
D105			HZS15N(B2)	ZENER DIODE		
D105			MTZJ15(B)	ZENER DIODE		

L : Scandinavia K : USA P : Canada R : Mexico C : China I : Malaysia  
Y : PX(Far East,Hawaii) T : England E : Europe G : Germany V : China(Shanghai)  
Y : AAFES(Europe) X : Australia Q : Russia H : Korea M : Other Areas Δ indicates safety critical components.

## PARTS LIST

KRF-V7030D/V8030D/VR-407/409



\* New Parts  
 Parts without **Parts No.** are not supplied.  
 Les articles non mentionnés dans le **Parts No.** ne sont pas fournis.  
 Teile ohne **Parts No.** werden nicht geliefert.

15

Ref. No	Add-ress	New Parts	Parts No.	Description	Desti-nation	Re-marks
D106,107			MA111	DIODE		
D108			UDZ6.2B	ZENER DIODE	EE1T	
D108			UDZ8.2B	ZENER DIODE		789
D109			UDZ10B	ZENER DIODE	EE1T	
D109			UDZ15B	ZENER DIODE		789
D110			UDZ13B	ZENER DIODE	EE1T	
D110			UDZ16B	ZENER DIODE		789
D111-115			MA111	DIODE		
D117-120			UDZ15B	ZENER DIODE		
D121			MA111	DIODE		
D122			UDZ3.9B	ZENER DIODE		
D123			HSS104A	DIODE		
D123			1SS133	DIODE		
D124			UDZ3.9B	ZENER DIODE		
D125,126			1SS133	DIODE	YMI	
D127-130			MA111	DIODE		
D201			DA204U	DIODE		
D201			MA143A	DIODE		
D201			1SS302	DIODE		
D203			HZS8.2N(B2)	ZENER DIODE		
D203			MTZJ8.2(B)	ZENER DIODE		
D204			HZS5.1N(B2)	ZENER DIODE		
D204			MTZJ5.1(B)	ZENER DIODE		
D209			HZS3.3N(B2)	ZENER DIODE		
D209			MTZJ3.3(B)	ZENER DIODE		
D211			MA111	DIODE	EE1T	
D213			MA111	DIODE		
D601			S1ZB20(4101)	DIODE		
D602-605			HSS104A	DIODE		
D602-605			1SS133	DIODE		
D608			HSS104A	DIODE	KPK1	
D608			RB721Q	DIODE	EE1T	
D608			RB721Q	DIODE	YMI	
D608			1SS133	DIODE	KPK1	
IC101		*	STK412-020A	HYBRID IC		
IC102		*	STK413-020A	HYBRID IC		
IC103		*	KIA7812API	ANALOGUE IC		
IC104		*	KIA7912PI	ANALOGUE IC		
IC105			NJM4580ED	ANALOGUE IC		
IC106			NJU7313AM	ANALOGUE IC		
IC107,108			NJM4565M	ANALOGUE IC		
IC109			NJU7313AM	ANALOGUE IC		
IC110-112			NJM4565M	ANALOGUE IC		
IC201			LA1837	ANALOGUE IC	EE1T	
IC201			LA1837	ANALOGUE IC	KPK1	
IC201			LA1838	ANALOGUE IC	YMI	
IC202			LC72131	MOS-IC		
IC601			XC62FP5102P	ANALOGUE IC	KPK1	
IC602			BA05T	ANALOGUE IC	EE1T	
IC602			BA05T	ANALOGUE IC	YMI	
Q1 ,2			2SC1740S(Q,R)	TRANSISTOR		
Q1 ,2			2SC2785(F,E)	TRANSISTOR		3
Q3 ,4			2SD2351	TRANSISTOR		8
Q3 ,4			2SD2351	TRANSISTOR	XMI	9
Q3 ,4			2SD2351	TRANSISTOR	Y	

L : Scandinavia K : USA P : Canada R : Mexico C : China I : Malaysia  
 Y : PX(Far East,Hawaii) T : England E : Europe G : Germany V : China(Shanghai)  
 Y : AAFES(Europe) X : Australia Q : Russia H : Korea M : Other Areas  $\Delta$  indicates safety critical components .

\* New Parts  
 Parts without **Parts No.** are not supplied.  
 Les articles non mentionnés dans le **Parts No.** ne sont pas fournis.  
 Teile ohne **Parts No.** werden nicht geliefert.

15

Ref. No	Add-ress	New Parts	Parts No.	Description	Desti-nation	Re-marks
Q5 ,6			2SD2351	TRANSISTOR		
Q7 ,8			2SC1740S(Q,R)	TRANSISTOR		
Q7 ,8			2SC2785(F,E)	TRANSISTOR		
Q9 ,10			2SD2351	TRANSISTOR	E	3
Q9 ,10			2SD2351	TRANSISTOR	XMI	8
Q9 ,10			2SD2351	TRANSISTOR	Y	9
Q11 ,12			2SD2351	TRANSISTOR		
Q13 ,14			2SC1740S(Q,R)	TRANSISTOR		
Q13 ,14			2SC2785(F,E)	TRANSISTOR		
Q15			2SD2351	TRANSISTOR	E	3
Q15			2SD2351	TRANSISTOR	XMI	8
Q15			2SD2351	TRANSISTOR	Y	9
Q16			2SD2351	TRANSISTOR		
Q17			2SC2878(B)	TRANSISTOR		
Q51 -53			2SA1576A(R,S)	TRANSISTOR		
Q51 -53			2SB1218A(Q,R)	TRANSISTOR		
Q54			2SB1640	TRANSISTOR		
Q113-117			2SC3906K	TRANSISTOR		
Q118			2SA1576A(R,S)	TRANSISTOR		
Q118			2SB1218A(Q,R)	TRANSISTOR		
Q119,120			2SC3906K	TRANSISTOR		
Q121			2SA1576A(R,S)	TRANSISTOR		
Q121			2SB1218A(Q,R)	TRANSISTOR		
Q122,123			2SC1845(F,E)	TRANSISTOR		
Q132			2SC3906K	TRANSISTOR		
Q133			2SB1566	TRANSISTOR		
Q134			2SC1845(F,E)	TRANSISTOR		
Q135			2SA1576A(R,S)	TRANSISTOR		
Q135			2SB1218A(Q,R)	TRANSISTOR		
Q136			UN5219	DIGITAL TRANSISTOR		
Q137			2SD2395	TRANSISTOR		
Q138			2SB1640	TRANSISTOR		
Q139-142			DTC123JUA	DIGITAL TRANSISTOR		
Q201			2SC4081(R,S)	TRANSISTOR		
Q201			2SD1819A(Q,R)	TRANSISTOR		
Q202			2SA1576A(R,S)	TRANSISTOR		
Q202			2SB1218A(Q,R)	TRANSISTOR		
Q203,204			2SD1819A(Q,R)	TRANSISTOR		
Q206,207			2SC4081(R,S)	TRANSISTOR		
Q206,207			2SD1819A(Q,R)	TRANSISTOR	YMI	
Q210,211			2SD1757K	TRANSISTOR	EE1T	
Q212			2SA1576A(R,S)	TRANSISTOR	EE1T	
Q212			2SB1218A(Q,R)	TRANSISTOR	EE1T	
Q214			2SA1576A(R,S)	TRANSISTOR		
Q214			2SB1218A(Q,R)	TRANSISTOR		
Q601			2SC1740S(Q,R)	TRANSISTOR		
Q601			2SC2785(F,E)	TRANSISTOR		
A1			W02-2584-05	FM FRONT-END ASSY	EE1T	
A1			W02-2622-05	FM FRONT-END ASSY		789
<b>PREAMPLIFIER UNIT (X08-3010-XX)</b>						
C1 ,2			CE04RW1C100M	ELECTRO	10UF	16WV
C3			CK73FB1H103K	CHIP C	0.010UF	K
C4			CC73FCH1H101J	CHIP C	100PF	J
C5 ,6			CK73FB1H222K	CHIP C	2200PF	K

L : Scandinavia K : USA P : Canada R : Mexico C : China I : Malaysia  
 Y : PX(Far East,Hawaii) T : England E : Europe G : Germany V : China(Shanghai)  
 Y : AAFES(Europe) X : Australia Q : Russia H : Korea M : Other Areas  $\Delta$  indicates safety critical components .

PARTS LIST

KRF-V7030D/V8030D/MR-407/409

\* New Parts

Parts without **Parts No.** are not supplied.  
 Les articles non mentionnés dans le **Parts No.** ne sont pas fournis.  
 Teile ohne **Parts No.** werden nicht geliefert.

17

Ref. No	Add-ress	New Parts	Parts No.	Description	Desti-nation	Re-marks
C7 ,8			CK73FB1E104K	CHIP C	0.10UF	K
C9 ,10			CE04RW1C4R7M	ELECTRO	4.7UF	16WV
C21			CK73FB1E104K	CHIP C	0.10UF	K
C22			CE04LW1H100M	ELECTRO	10UF	50WV
C23			CK73FB1H102K	CHIP C	1000PF	K
C24 ,25			CK73FB1E104K	CHIP C	0.10UF	K
C26			CK73FF1C105Z	CHIP C	1.0UF	Z
C27		*	C91-1597-05	CERAMIC	4.7UF	Z
C29			CK73FB1H103K	CHIP C	0.010UF	K
C31			CC73FCH1H220J	CHIP C	22PF	J
C32			CK73FB1H472K	CHIP C	4700PF	K
C33			CC73FCH1H220J	CHIP C	22PF	J
C34			CK73FB1H472K	CHIP C	4700PF	K
C35 ,36			CK73FF1C105Z	CHIP C	1.0UF	Z
C37			CK73FF1C105Z	CHIP C	1.0UF	Z
C37			CK73FF1C105Z	CHIP C	1.0UF	Z
C41			CC73FCH1H220J	CHIP C	22PF	J
C42			CC73FCH1H270J	CHIP C	27PF	J
C43 ,44			CK73FB1H102K	CHIP C	1000PF	K
C45			CK73FB1H103K	CHIP C	0.010UF	K
C46			CC73FCH1H220J	CHIP C	22PF	J
C54 ,55			CC73FCH1H220J	CHIP C	22PF	J
C56			CK73FB1H102K	CHIP C	1000PF	K
C57			CK73FF1C105Z	CHIP C	1.0UF	Z
C58 ,59			CK73FB1H103K	CHIP C	0.010UF	K
C103,104			CK73FF1C105Z	CHIP C	1.0UF	Z
C105,106			CK73FB1H182K	CHIP C	1800PF	K
C107,108			CK73FB1H222K	CHIP C	2200PF	K
C111,112			CC73FCH1H101J	CHIP C	100PF	J
C121,122			CC73FCH1H220J	CHIP C	22PF	J
C125			CK73FB1H103K	CHIP C	0.010UF	K
C126			CC73FCH1H101J	CHIP C	100PF	J
C141			CC73FCH1H101J	CHIP C	100PF	J
C151,152			CK73FF1C225Z	CHIP C	2.2UF	Z
C153,154			CC73FCH1H101J	CHIP C	100PF	J
C155,156			CK73FF1C105Z	CHIP C	1.0UF	Z
C157-160			CK73FF1C225Z	CHIP C	2.2UF	Z
C161,162			CK73FB1H822K	CHIP C	8200PF	K
C163,164			CK73FB1H153K	CHIP C	0.015UF	K
C163,164			CK73FB1H153K	CHIP C	0.015UF	K
C163,164			CK73FB1H333K	CHIP C	0.033UF	K
C165,166			CK73FB1C334K	CHIP C	0.33UF	K
C165,166			CK73FB1C334K	CHIP C	0.33UF	K
C165,166			CK73FB1C474K	CHIP C	0.47UF	K
C167,168			CK73FF1C225Z	CHIP C	2.2UF	Z
C169,170			CK73FB1H222K	CHIP C	2200PF	K
C177-182			CK73FF1C225Z	CHIP C	2.2UF	Z
C183			CK73FF1C105Z	CHIP C	1.0UF	Z
C184			CC73FCH1H221J	CHIP C	220PF	J
C185,186			CK73FB1E104K	CHIP C	0.10UF	K
C187,188			CK73FB1H102K	CHIP C	1000PF	K
C203,204			CK73FF1C105Z	CHIP C	1.0UF	Z
C205,206			CK73FB1H222K	CHIP C	2200PF	K
C207,208			CK73FB1H102K	CHIP C	1000PF	K
C209			CK73FB1H472K	CHIP C	4700PF	K

L : Scandinavia K : USA P : Canada R : Mexico C : China I : Malaysia  
 Y : PX(Far East,Hawaii) T : England E : Europe G : Germany V : China(Shanghai)  
 Y : AAFES(Europe) X : Australia Q : Russia H : Korea M : Other Areas  $\Delta$  indicates safety critical components.

\* New Parts

Parts without **Parts No.** are not supplied.  
 Les articles non mentionnés dans le **Parts No.** ne sont pas fournis.  
 Teile ohne **Parts No.** werden nicht geliefert.

18

Ref. No	Add-ress	New Parts	Parts No.	Description	Desti-nation	Re-marks
C209			CK73FB1H472K	CHIP C	4700PF	K
C210-212			CC73FCH1H101J	CHIP C	100PF	J
C251-256			CC73FCH1H221J	CHIP C	220PF	J
C303,304			CK73FF1C105Z	CHIP C	1.0UF	Z
C305			CK73FB1H182K	CHIP C	1800PF	K
C306			CK73FB1H682K	CHIP C	6800PF	K
C307			CC73FCH1H222K	CHIP C	2200PF	K
C308			CK73FB1H822K	CHIP C	8200PF	K
C309			CK73FB1H103K	CHIP C	0.010UF	K
C310,311			CC73FCH1H101J	CHIP C	100PF	J
C401-403			CK73FB1H103K	CHIP C	0.010UF	K
C411-414			CC73FCH1H220J	CHIP C	22PF	J
C415-418			CC73FCH1H101J	CHIP C	100PF	J
C419			CC73FCH1H100D	CHIP C	10PF	D
C450			CK73FB1H103K	CHIP C	0.010UF	K
C451			CK73FB1E104K	CHIP C	0.10UF	K
C452			CE04LW1C222M	ELECTRO	2200UF	16WV
C453,454			CK73FB1E104K	CHIP C	0.10UF	K
C455			CE04LW1A101M	ELECTRO	100UF	10WV
C456,457			CK73FB1E104K	CHIP C	0.10UF	K
C458			C92-0047-05	CHIP-ELE	47UF	6.3WV
C459,460			CK73FB1E104K	CHIP C	0.10UF	K
C461			CE04LW1E470M	ELECTRO	47UF	25WV
C501-504			CK73FB1E104K	CHIP C	0.10UF	K
C505			CK73FB1H102K	CHIP C	1000PF	K
C506			CC73FCH1H471J	CHIP C	470PF	J
C507			CK73FB1H103K	CHIP C	0.010UF	K
C508			CE04LW1H2R2M	ELECTRO	2.2UF	50WV
C509			CE04LW1E470M	ELECTRO	47UF	25WV
C510,511			CK73FB1H103K	CHIP C	0.010UF	K
C601			CC73FCH1H470J	CHIP C	47PF	J
C602			CE04LW1E470M	ELECTRO	47UF	25WV
C603			CC73FCH1H470J	CHIP C	47PF	J
C604			CE04LW1E470M	ELECTRO	47UF	25WV
C605			CC73FCH1H470J	CHIP C	47PF	J
C606			CE04LW1E470M	ELECTRO	47UF	25WV
C607			CC73FCH1H470J	CHIP C	47PF	J
C608			CE04LW1E470M	ELECTRO	47UF	25WV
C609,610			CC73FCH1H470J	CHIP C	47PF	J
C611			CE04LW1E470M	ELECTRO	47UF	25WV
C621,622			CK73FB1E104K	CHIP C	0.10UF	K
C651,652			CC73FCH1H470J	CHIP C	47PF	J
C653			CK73FB1H103K	CHIP C	0.010UF	K
C654			CE04LW1E470M	ELECTRO	47UF	25WV
C655,656			CC73FCH1H470J	CHIP C	47PF	J
C657			CK73FB1H103K	CHIP C	0.010UF	K
C658			CE04LW1E470M	ELECTRO	47UF	25WV
C659,660			CC73FCH1H470J	CHIP C	47PF	J
C661			CK73FB1H103K	CHIP C	0.010UF	K
C662			CE04LW1E470M	ELECTRO	47UF	25WV
C663,664			CC73FCH1H470J	CHIP C	47PF	J
C665			CK73FB1H103K	CHIP C	0.010UF	K
C666			CE04LW1E470M	ELECTRO	47UF	25WV
C667-670			CC73FCH1H470J	CHIP C	47PF	J
C671			CK73FB1H103K	CHIP C	0.010UF	K

L : Scandinavia K : USA P : Canada R : Mexico C : China I : Malaysia  
 Y : PX(Far East,Hawaii) T : England E : Europe G : Germany V : China(Shanghai)  
 Y : AAFES(Europe) X : Australia Q : Russia H : Korea M : Other Areas  $\Delta$  indicates safety critical components.

\* New Parts

Parts without **Parts No.** are not supplied.  
Les articles non mentionnés dans le **Parts No.** ne sont pas fournis.  
Teile ohne **Parts No.** werden nicht geliefert.

19

Ref. No	Add-ress	New Parts	Parts No.	Description	Desti-nation	Re-marks
C672			CE04LW1E470M	ELECTRO 47UF 25WV		
C681,682			CE04LW1H100M	ELECTRO 10UF 50WV		
C751,752			CC73FCH1H221J	CHIP C 220PF J		
C753			CK73FB1H103K	CHIP C 0.010UF K		
CN1		*	E40-8485-05	FLAT CABLE CONNECTOR		
CN2		*	E40-8484-05	FLAT CABLE CONNECTOR		
CN3			E40-4297-05	FLAT CABLE CONNECTOR		
CN5			E40-4248-05	PIN ASSY		
CN5			E40-8358-05	PIN ASSY		
J1			E63-1080-05	PIN JACK		
J2		*	E63-1139-05	PIN JACK		
J61		*	E63-1142-05	PIN JACK		
J65 ,66			E56-0011-05	CYLINDRICAL RECEPTACLE		
J75			E11-0293-05	MINIATURE PHONE JACK(2P)		
E1			J11-0809-05	WIRE CLAMPER		
L31 ,32		*	L92-0511-05	CHIP FERRITE		
L41		*	L92-0510-05	CHIP FERRITE		
X1		*	L77-2296-05	CRYSTAL RESONATOR(12.288MHZ)		
CP41-44			R90-0728-05	MULTI-COMP 180 X4		
CP51,52			R90-0714-05	MULTI-COMP 10K X4		
R1 ,2			RK73FB2A562J	CHIP R 5.6K J 1/10W		
R3 ,4			RK73FB2A101J	CHIP R 100 J 1/10W		
R5 ,6			RK73FB2A471J	CHIP R 470 J 1/10W		
R7 -10			RK73FB2A472J	CHIP R 4.7K J 1/10W		
R11 ,12			RK73FB2A471J	CHIP R 470 J 1/10W		
R20		*	R92-1946-05	METAL GLAZE 4.7 J 1/4W		
R21			RK73FB2A221J	CHIP R 220 J 1/10W		
R31 ,32			RK73FB2A820J	CHIP R 82 J 1/10W		
R33			RK73FB2A471J	CHIP R 470 J 1/10W		
R34			RD14NB2E4R7J	RD 4.7 J 1/4W		
R35			RK73FB2A471J	CHIP R 470 J 1/10W		
R36			RD14NB2E4R7J	RD 4.7 J 1/4W		
R37			RK73FB2A471J	CHIP R 470 J 1/10W		89
R37			RK73FB2A471J	CHIP R 470 J 1/10W	E	
R38			RD14NB2E4R7J	RD 4.7 J 1/4W		89
R38			RD14NB2E4R7J	RD 4.7 J 1/4W	E	
R41 ,42			RK73FB2A105J	CHIP R 1.0M J 1/10W		
R43 -45			RK73FB2A221J	CHIP R 220 J 1/10W		
R54			RK73FB2A912J	CHIP R 9.1K J 1/10W		
R55 -58			RK73FB2A221J	CHIP R 220 J 1/10W		
R59			RK73FB2A101J	CHIP R 100 J 1/10W		
R66			RK73FB2A104J	CHIP R 100K J 1/10W		
R67			RK73FB2A103J	CHIP R 10K J 1/10W		
R68			RK73FB2A221J	CHIP R 220 J 1/10W		
R101,102			RK73FB2A222J	CHIP R 2.2K J 1/10W		
R103,104			RK73FB2A104J	CHIP R 100K J 1/10W		
R107,108			RK73FB2A222J	CHIP R 2.2K J 1/10W		
R109,110			RK73FB2A103J	CHIP R 10K J 1/10W		
R111,112			RK73FB2A472J	CHIP R 4.7K J 1/10W		
R113,114			RK73FB2A221J	CHIP R 220 J 1/10W		
R121-124			RK73FB2A103J	CHIP R 10K J 1/10W		
R125,126			RK73FB2A101J	CHIP R 100 J 1/10W		
R127,128			RK73FB2A242J	CHIP R 2.4K J 1/10W		

L : Scandinavia K : USA P : Canada R : Mexico C : China I : Malaysia  
Y : PX(Far East,Hawaii) T : England E : Europe G : Germany V : China(Shanghai)  
Y : AAFES(Europe) X : Australia Q : Russia H : Korea M : Other Areas  $\Delta$  indicates safety critical components.

\* New Parts

Parts without **Parts No.** are not supplied.  
Les articles non mentionnés dans le **Parts No.** ne sont pas fournis.  
Teile ohne **Parts No.** werden nicht geliefert.

20

Ref. No	Add-ress	New Parts	Parts No.	Description	Desti-nation	Re-marks
R151-156			RK73FB2A100J	CHIP R 10 J 1/10W		
R157,158			RK73FB2A102J	CHIP R 1.0K J 1/10W		
R159-164			RK73FB2A101J	CHIP R 100 J 1/10W		
R165			RK73FB2A751J	CHIP R 750 J 1/10W		
R166			RK73FB2A272J	CHIP R 2.7K J 1/10W		
R168,169			RK73FB2A1R0J	CHIP R 1 J 1/10W		
R170,171			RK73FB2A471J	CHIP R 470 J 1/10W		
R172-175			RK73FB2A473J	CHIP R 47K J 1/10W		
R201,202			RK73FB2A332J	CHIP R 3.3K J 1/10W		
R203,204			RK73FB2A104J	CHIP R 100K J 1/10W		
R207,208			RK73FB2A222J	CHIP R 2.2K J 1/10W		
R209,210			RK73FB2A272J	CHIP R 2.7K J 1/10W		
R211,212			RK73FB2A562J	CHIP R 5.6K J 1/10W		
R213,214			RK73FB2A221J	CHIP R 220 J 1/10W		
R215,216			RK73FB2A472J	CHIP R 4.7K J 1/10W		
R217,218			RK73FB2A562J	CHIP R 5.6K J 1/10W		
R251,252			RK73FB2A153J	CHIP R 15K J 1/10W		
R253,254			RK73FB2A223J	CHIP R 22K J 1/10W		
R255,256			RK73FB2A103J	CHIP R 10K J 1/10W		
R257,258			RK73FB2A223J	CHIP R 22K J 1/10W		
R259,260			RK73FB2A103J	CHIP R 10K J 1/10W		
R261,262			RK73FB2A223J	CHIP R 22K J 1/10W		
R301			RK73FB2A222J	CHIP R 2.2K J 1/10W		
R302			RK73FB2A103J	CHIP R 10K J 1/10W		
R303,304			RK73FB2A104J	CHIP R 100K J 1/10W		
R307			RK73FB2A222J	CHIP R 2.2K J 1/10W		
R308			RK73FB2A123J	CHIP R 12K J 1/10W		
R309,310			RK73FB2A103J	CHIP R 10K J 1/10W		
R311,312			RK73FB2A472J	CHIP R 4.7K J 1/10W		
R313,314			RK73FB2A221J	CHIP R 220 J 1/10W		
R401-406			RK73FB2A471J	CHIP R 470 J 1/10W		
R407			RK73FB2A473J	CHIP R 47K J 1/10W		
R412			RK73FB2A221J	CHIP R 220 J 1/10W		
R426,427			RK73FB2A221J	CHIP R 220 J 1/10W		
R428			RK73FB2A1R0J	CHIP R 1 J 1/10W		
R428			RK73FB2A1R0J	CHIP R 1 J 1/10W	E1T	
R431,432			RK73FB2A103J	CHIP R 10K J 1/10W		
R433			RK73FB2A473J	CHIP R 47K J 1/10W		
R433			RK73FB2A473J	CHIP R 47K J 1/10W	E	89
R434			RK73FB2A101J	CHIP R 100 J 1/10W		89
R434			RK73FB2A101J	CHIP R 100 J 1/10W	E	
R450			R92-1918-05	CHIP R 0.33 J 1/4W		
R451-453		*	R92-1945-05	METAL GLAZE 1 J 1/4W		
R454		*	R92-1946-05	METAL GLAZE 4.7 J 1/4W		
R461,462		*	RK73FB2A221J	CHIP R 220 J 1/10W		
R463			RK73FB2A473J	CHIP R 47K J 1/10W		
R464			RK73FB2A472J	CHIP R 4.7K J 1/10W		
R465			RK73FB2A102J	CHIP R 1.0K J 1/10W		
R501-503			RK73FB2A221J	CHIP R 220 J 1/10W		
R505			RK73FB2A103J	CHIP R 10K J 1/10W		
R514			RK73FB2A101J	CHIP R 100 J 1/10W		
R515			RK73FB2A221J	CHIP R 220 J 1/10W		
R516			RK73FB2A103J	CHIP R 10K J 1/10W		
R517			RK73FB2A221J	CHIP R 220 J 1/10W		
R518			RK73FB2A472J	CHIP R 4.7K J 1/10W		

L : Scandinavia K : USA P : Canada R : Mexico C : China I : Malaysia  
Y : PX(Far East,Hawaii) T : England E : Europe G : Germany V : China(Shanghai)  
Y : AAFES(Europe) X : Australia Q : Russia H : Korea M : Other Areas  $\Delta$  indicates safety critical components.

PARTS LIST

KRF-V7030D/V8030D/MR-407/409

\* New Parts  
 Parts without **Parts No.** are not supplied.  
 Les articles non mentionnés dans le **Parts No.** ne sont pas fournis.  
 Teile ohne **Parts No.** werden nicht geliefert.

21

Ref. No	Add-ress	New Parts	Parts No.	Description	Desti-nation	Re-marks
R519			RK73FB2A221J	CHIP R 220 J 1/10W		
R520,521			RK73FB2A103J	CHIP R 10K J 1/10W		
R522,523			RK73FB2A472J	CHIP R 4.7K J 1/10W		
R524			RK73FB2A333J	CHIP R 33K J 1/10W		
R527			RK73FB2A103J	CHIP R 10K J 1/10W		
R601			RK73FB2A820J	CHIP R 82 J 1/10W		
R603			RK73FB2A820J	CHIP R 82 J 1/10W		
R605			RK73FB2A820J	CHIP R 82 J 1/10W		
R607			RK73FB2A820J	CHIP R 82 J 1/10W		
R609			RK73FB2A104J	CHIP R 100K J 1/10W		
R610			RK73FB2A680J	CHIP R 68 J 1/10W		
R611			RK73FB2A104J	CHIP R 100K J 1/10W		
R612			RK73FB2A680J	CHIP R 68 J 1/10W		
R631,632			RK73FB2A681J	CHIP R 680 J 1/10W		
Δ R633,634		*	R92-1954-05	METAL GLAZE 100 J 1/10W	EE1T	
Δ R633,634		*	R92-1954-05	METAL GLAZE 100 J 1/10W	KPIXY	
Δ R633,634		*	R92-1957-05	METAL GLAZE RESISTOR	M	
Δ R635,636		*	R92-1954-05	METAL GLAZE 100 J 1/10W	M	
R651,658			RK73FB2A820J	CHIP R 82 J 1/10W		
R659,660			RK73FB2A104J	CHIP R 100K J 1/10W		
R661,662			RK73FB2A680J	CHIP R 68 J 1/10W		
R663,664			RK73FB2A104J	CHIP R 100K J 1/10W		
R665,666			RK73FB2A680J	CHIP R 68 J 1/10W		
Δ R681,682			RD14NB2E4R7J	RD 4.7 J 1/4W		
D1			DAN202U	DIODE		
D1			MA142WK	DIODE		
D1			1SS301	DIODE		
D2			DAP202U	DIODE		
D2			MA142WA	DIODE		
D2			1SS300	DIODE		
D3			DAN202U	DIODE		
D3			MA142WK	DIODE		
D3			1SS301	DIODE		
D6			MA111	DIODE		
Δ D41			S1ZB20(4072)	DIODE		
D42,43			UDZ5.6B	ZENER DIODE		
D44			UDZ3.9B	ZENER DIODE		
D51,52			MA111	DIODE		
D61,62			UDZ5.6B	ZENER DIODE		
D75,76			MA111	DIODE		
D151,152			UDZ7.5B	ZENER DIODE		
IC1			NJM4565MD	IC(OP AMP X2)		
IC2		*	AK4527-VQ	MOS-IC		
IC4			TC7WU04FU	MOS-IC		
IC5		*	AK4110-VF	MOS-IC		
IC6		*	TC7WH123FU	MOS-IC		
IC11			NJM4565MD	IC(OP AMP X2)		
IC12			NJU7311AM	MOS-IC		
IC13			NJM4565MD	IC(OP AMP X2)		
IC14			NJU7311AM	MOS-IC		
IC15			M62446FP	ANALOGUE IC		
IC21			NJM4565MD	IC(OP AMP X2)		
IC31			NJM4565MD	IC(OP AMP X2)		
IC41		*	TC74HC07AF	MOS-IC		

L : Scandinavia K : USA P : Canada R : Mexico C : China I : Malaysia  
 Y : PX(Far East,Hawaii) T : England E : Europe G : Germany V : China(Shanghai)  
 Y : AAFES(Europe) X : Australia Q : Russia H : Korea M : Other Areas Δ indicates safety critical components.

22

\* New Parts  
 Parts without **Parts No.** are not supplied.  
 Les articles non mentionnés dans le **Parts No.** ne sont pas fournis.  
 Teile ohne **Parts No.** werden nicht geliefert.

Ref. No	Add-ress	New Parts	Parts No.	Description	Desti-nation	Re-marks
IC42			TC74HCT7007AF	MOS-IC		
IC43		*	TC7WH126FU	MOS-IC	E	89
IC43		*	TC7WH126FU	MOS-IC	E	3
IC44		*	AT25256WS2701	MOS-IC	E	89
IC44		*	AT25256WS2701	MOS-IC	E	3
Δ IC45		*	TA48M05F	ANALOGUE IC		
Δ IC46		*	TA48M033F	ANALOGUE IC		
Δ IC47		*	TA48M025F	ANALOGUE IC		
IC51		*	CS493263-CLR	MOS-IC		
IC61			NJM2279M	ANALOGUE IC		
IC62		*	NJU4052BV	MOS-IC		
IC62		*	TC74HC4052AFT	MOS-IC		
IC66,67			NJM2279M	ANALOGUE IC		
IC68		*	NJU4052BV	MOS-IC		
IC68		*	TC74HC4052AFT	MOS-IC		
Q1			DTC124EUA	DIGITAL TRANSISTOR		
Q1			UN5212	DIGITAL TRANSISTOR		
Δ Q15			2SD1664(Q,R)	TRANSISTOR		
Δ Q15		*	2SD1963(R,S)-G	TRANSISTOR		
Δ Q16			2SB1132(Q,R)	TRANSISTOR		
Δ Q16		*	2SB1308(Q,R)-G	TRANSISTOR		
Q41			2SC4081(R,S)	TRANSISTOR		
Q41			2SD1819A(Q,R)	TRANSISTOR		
Q42			2SA1576A(R,S)	TRANSISTOR		
Q42			2SB1218A(Q,R)	TRANSISTOR		
Δ Q61			2SD1664(Q,R)	TRANSISTOR		
Δ Q61		*	2SD1963(R,S)-G	TRANSISTOR		
Δ Q62			2SB1132(Q,R)	TRANSISTOR		
Δ Q62		*	2SB1308(Q,R)-G	TRANSISTOR		
A1 ,2		*	W02-2716-05	OPTIC RECEIVING MODULE		
A3			W02-2717-05	OSCILLATING MODULE	E	89
A3		*	W02-2717-05	OSCILLATING MODULE	E	
<b>DISPLAY UNIT (X14-7090-XX)</b>						
D1			B30-2567-05	LED(RED(80) HI-BR)		
D2 -6			B30-2545-05	LED(RED3(160))		
C1			CE04RW0J331M	ELECTRO 330UF 6.3WV	KPK1	
C1			CE04RW1A101M	ELECTRO 100UF 10WV	EE1T	
C1			CE04RW1A101M	ELECTRO 100UF 10WV	YMIX	
C2			CK73FB1H103K	CHIP C 0.010UF K		
C3			CE04RW1H010M	ELECTRO 1.0UF 50WV		
C4 ,5			CE04RW1C100M	ELECTRO 10UF 16WV		
C6		*	CE04RW0J100M	ELECTRO 10UF 6.3WV		
C7			CK73FB1H103K	CHIP C 0.010UF K		
C9			CC73FCH1H470J	CHIP C 47PF J		
C10 -19			CK73FB1H103K	CHIP C 0.010UF K		
C20 ,21			CK73FB1C104K	CHIP C 0.10UF K		
C22			CK73FF1C105Z	CHIP C 1.0UF Z		
C23			CE04RW0J470M	ELECTRO 47UF 6.3WV		
C24			CE04RW0J470M	ELECTRO 47UF 6.3WV	EE1T	
C25			CK73FB1H103K	CHIP C 0.010UF K	EE1T	
C26 ,27			CC73FCH1H270J	CHIP C 27PF J	EE1T	
C28			CC73FCH1H561J	CHIP C 560PF J	EE1T	
C29			CC73FCH1H271J	CHIP C 270PF J	EE1T	
C30		*	CE04RW1V2R2M	ELECTRO 2.2UF 35WV	EE1T	

L : Scandinavia K : USA P : Canada R : Mexico C : China I : Malaysia  
 Y : PX(Far East,Hawaii) T : England E : Europe G : Germany V : China(Shanghai)  
 Y : AAFES(Europe) X : Australia Q : Russia H : Korea M : Other Areas Δ indicates safety critical components.

\* New Parts

Parts without **Parts No.** are not supplied.  
Les articles non mentionnés dans le **Parts No.** ne sont pas fournis.  
Teile ohne **Parts No.** werden nicht geliefert.

23

Ref. No	Add-ress	New Parts	Parts No.	Description	Desti-nation	Re-marks
C31			CC73FCH1H101J	CHIP C	100PF	J
C32			CE04RW0J220M	ELECTRO	22UF	6.3WV
C33 -35			CC73FCH1H101J	CHIP C	100PF	J
C36 ,37			CC73FCH1H470J	CHIP C	47PF	J
C38		*	CE04RW1H330M	ELECTRO	33UF	50WV
C39			CK73FB1H103K	CHIP C	0.010UF	K
C40			C90-1826-05	BACKUP-C	0.047F	5.5WV
C41			C90-1826-05	BACKUP-C	0.047F	5.5WV
C42			CK73FB1H103K	CHIP C	0.010UF	K
			CK73FB1H103K	CHIP C	0.010UF	K
C43 ,44			CC73FCH1H101J	CHIP C	100PF	J
C45 ,46			CC73FCH1H470J	CHIP C	47PF	J
C47			CC73FCH1H101J	CHIP C	100PF	J
C48			CC73FCH1H101J	CHIP C	100PF	J
C49			CE04RW0J331M	ELECTRO	330UF	6.3WV
C50			CC73FCH1H101J	CHIP C	100PF	J
C51		*	CE04RW1H2R2M	ELECTRO	2.2UF	50WV
C52			CK73FB1H103K	CHIP C	0.010UF	K
C53			CC73FCH1H101J	CHIP C	100PF	J
C54		*	CE04RW1H4R7M	ELECTRO	4.7UF	50WV
C55			CC73FCH1H470J	CHIP C	47PF	J
C56			CC73FCH1H220J	CHIP C	22PF	J
C57			CC73FCH1H221J	CHIP C	220PF	J
C58			CC73FCH1H470J	CHIP C	47PF	J
C59			CK73FF1C105Z	CHIP C	1.0UF	Z
C61			CC73FCH1H101J	CHIP C	100PF	J
C101-107			CC73FCH1H101J	CHIP C	100PF	J
CN1		*	E40-8510-05	FLAT CABLE CONNECTOR		
CN2		*	E40-8504-05	FLAT CABLE CONNECTOR		
CN3			E40-3247-05	PIN ASSY		
CN5			E40-3261-05	PIN ASSY		
J1			E11-0272-05	PHONE JACK		
J2			E63-1035-05	PIN JACK		
J2		*	E63-1147-05	PIN JACK		
J3			E06-0709-05	CYLINDRICAL RECEPTACLE		
-			J19-5928-13	HOLDER		
-			J19-5928-13	HOLDER		
E5 ,6			J11-0808-05	WIRE CLAMPER		
X1		*	L78-0714-05	RESONATOR (8MHZ)		
X2			L77-2002-05	CRYSTAL RESONATOR(4.332MHZ)		EE1T
CP1			R90-0855-05	MULTI-COMP	100KX5	J
CP2 ,3			R90-0482-05	MULTI-COMP	100KX4	J 1/6W
CP501			R90-0855-05	MULTI-COMP	100KX5	J
CP502			R90-0850-05	MULTI-COMP	100KX3	J 1/6W
R4			RK73FB2A102J	CHIP R	1.0K	J 1/10W
R5			RK73FB2A103J	CHIP R	10K	J 1/10W
R7			RK73FB2A104J	CHIP R	100K	J 1/10W
R8			RK73FB2A102J	CHIP R	1.0K	J 1/10W
R12			RK73FB2A331J	CHIP R	330	J 1/10W
R13 ,14			RK73FB2A104J	CHIP R	100K	J 1/10W
R15			RK73FB2A331J	CHIP R	330	J 1/10W
R29			RK73FB2A122J	CHIP R	1.2K	J 1/10W
R30 -34			RK73FB2A221J	CHIP R	220	J 1/10W

L : Scandinavia K : USA P : Canada R : Mexico C : China I : Malaysia  
Y : PX(Far East,Hawaii) T : England E : Europe G : Germany V : China(Shanghai)  
Y : AAFES(Europe) X : Australia Q : Russia H : Korea M : Other Areas  $\Delta$  indicates safety critical components.

\* New Parts

Parts without **Parts No.** are not supplied.  
Les articles non mentionnés dans le **Parts No.** ne sont pas fournis.  
Teile ohne **Parts No.** werden nicht geliefert.

24

Ref. No	Add-ress	New Parts	Parts No.	Description	Desti-nation	Re-marks
R36 ,37			RK73FB2A104J	CHIP R	100K	J 1/10W
R38 -43			RK73FB2A103J	CHIP R	10K	J 1/10W
R44 -49			RK73FB2A101J	CHIP R	100	J 1/10W
R50			RK73FB2A272J	CHIP R	2.7K	J 1/10W
R51			RK73FB2A102J	CHIP R	1.0K	J 1/10W
R52 ,53			RK73FB2A272J	CHIP R	2.7K	J 1/10W
R54 ,55			RK73FB2A103J	CHIP R	10K	J 1/10W
R54 ,55			RK73FB2A472J	CHIP R	4.7K	J 1/10W
R57 ,58			RK73FB2A223J	CHIP R	22K	J 1/10W
R59 -63			RK73FB2A104J	CHIP R	100K	J 1/10W
R64			RK73FB2A101J	CHIP R	100	J 1/10W
R65 ,66			RK73FB2A103J	CHIP R	10K	J 1/10W
R67			RD14NB2E222J	RD	2.2K	J 1/4W
R71 ,72			RK73FB2A473J	CHIP R	47K	J 1/10W
R83			RK73FB2A564J	CHIP R	560K	J 1/10W
R86			RD14NB2E152J	RD	1.5K	J 1/4W
R98			RK73FB2A104J	CHIP R	100K	J 1/10W
R107-109			RK73FB2A104J	CHIP R	100K	J 1/10W
R110			RK73FB2A1R0J	CHIP R	1	J 1/10W
R111			RK73FB2A101J	CHIP R	100	J 1/10W
R112			RK73FB2A473J	CHIP R	47K	J 1/10W
R113			RK73FB2A101J	CHIP R	100	J 1/10W
R114			RK73FB2A104J	CHIP R	100K	J 1/10W
R118			RK73FB2A104J	CHIP R	100K	J 1/10W
R119-126			RK73FB2A101J	CHIP R	100	J 1/10W
R127-129			RK73FB2A104J	CHIP R	100K	J 1/10W
R130			RK73FB2A102J	CHIP R	1.0K	J 1/10W
R141,142			RK73FB2A104J	CHIP R	100K	J 1/10W
R143			RK73FB2A101J	CHIP R	100	J 1/10W
R151,152			RK73FB2A101J	CHIP R	100	J 1/10W
R153,154			RK73FB2A104J	CHIP R	100K	J 1/10W
R155			RK73FB2A101J	CHIP R	100	J 1/10W
R156-158			RK73FB2A750J	CHIP R	75	J 1/10W
R161,162			RK73FB2A104J	CHIP R	100K	J 1/10W
R501,502			RK73FB2A104J	CHIP R	100K	J 1/10W
W503			R92-0679-05	CHIP R	0 OHM	
W505			R92-0679-05	CHIP R	0 OHM	YMIX
W507			R92-0679-05	CHIP R	0 OHM	EE1T
W509			R92-0679-05	CHIP R	0 OHM	
W514			R92-0679-05	CHIP R	0 OHM	
S4 -16			S70-0031-05	TACT SWITCH		
S19			S68-0107-05	PUSH SWITCH		EE1T
S19			S68-0107-05	PUSH SWITCH		YMIX
S1			T99-0602-05	ROTARY ENCODER		
S2 ,3		*	T99-0630-05	ROTARY ENCODER		
D7			HZS6.2N(B2)	ZENER DIODE		
D7			MTZJ6.2(B)	ZENER DIODE		
D8 ,9			RB721Q	DIODE		
D11 ,12			MA111	DIODE		
D13			HSS104A	DIODE		KPK1
D13			1SS133	DIODE		KPK1
D15 ,16			MA111	DIODE		
D17 -22			HSS104A	DIODE		
D17 -22			1SS133	DIODE		

L : Scandinavia K : USA P : Canada R : Mexico C : China I : Malaysia  
Y : PX(Far East,Hawaii) T : England E : Europe G : Germany V : China(Shanghai)  
Y : AAFES(Europe) X : Australia Q : Russia H : Korea M : Other Areas  $\Delta$  indicates safety critical components.

PARTS LIST

KRF-V7030D/V8030D/MR-407/409

\* New Parts

Parts without **Parts No.** are not supplied.Les articles non mentionnés dans le **Parts No.** ne sont pas fournis.Teile ohne **Parts No.** werden nicht geliefert.

25

## HOW TO READ THE PARTS LIST

## ABBREVIATION OF MODEL AND MASS PRODUCTION'S DESTINATIONS

Ref. No	Add-ress	New Parts	Parts No.	Description	Desti-nation	Re-marks
D24			HSS104A	DIODE	EE1TX	
D24			1SS133	DIODE	EE1TX	
D25			HSS104A	DIODE		7
D25			HSS104A	DIODE	E1T	3
D25			1SS133	DIODE		7
D25			1SS133	DIODE	E1T	3
D26			HSS104A	DIODE		89
D26			HSS104A	DIODE	E	3
D26			1SS133	DIODE		89
D26			1SS133	DIODE	E	3
D28			HSS104A	DIODE	EE1T	
D28			HSS104A	DIODE	YMIX	
D28			1SS133	DIODE	EE1T	
D28			1SS133	DIODE	YMIX	
D29			HSS104A	DIODE	X	
D29			1SS133	DIODE	X	
D30			HSS104A	DIODE	EE1T	
D30			1SS133	DIODE	EE1T	
D33			HSS104A	DIODE		
D33			1SS133	DIODE		
D35 ,36			MA111	DIODE	YMI	
ED1		*	SVA-11MS22	FLUORESCENT INDICATOR TUBE		
ED1		*	11-MT-120GK	FLUORESCENT INDICATOR TUBE		
IC1		*	MN101C35DRA	MI-COM IC		
IC2		*	S-80840ANY	ANALOGUE IC		
△ IC3		*	TA78057F	ANALOGUE IC	EE1T	
△ IC3		*	TA78057F	ANALOGUE IC	KPK1X	
IC4			BU1923F	ANALOGUE IC	EE1T	
IC5			S-80840ANY	ANALOGUE IC	YMI	
△ IC6			XC62FP5102P	ANALOGUE IC	YMI	
Q1			2SC4081(R,S)	TRANSISTOR		
Q2			2SA1576A(R,S)	TRANSISTOR		
Q3 -5			2SC4081(R,S)	TRANSISTOR		
Q6 -11			UN5219	DIGITAL TRANSISTOR		
Q12 ,13			2SA1576A(R,S)	TRANSISTOR		
Q14			DTA124EUA	DIGITAL TRANSISTOR		
Q14			UN5112	DIGITAL TRANSISTOR		
A1			W02-2625-05	OPTIC RECEIVING MODULE		

MODEL	ABB.	Australia	Canada	China	England	Europe	Germany	Korea	Malaysia
VR-407		-	P	-	-	-	-	-	-
KRF-V7030D	7	-	-	-	-	-	-	-	-
KRF-V7030D-S		X	-	-	-	-	-	-	I
VR-407-S		-	-	-	-	-	-	-	-
VR-409	9	-	P	-	-	-	-	-	-
KRF-V8030D		-	-	-	-	-	-	-	-
KRF-V8030D-S	8	X	-	-	-	-	-	-	I
KRF-V8030D		-	-	-	-	E	-	-	-
KRF-V7030D	3	-	-	-	T	E1	-	-	-
		-	-	-	-	-	-	-	-
MODEL	ABB.	Mexico	PX/AAFES	Russia	Scandinavia	Shanghai	USA	Other area	
VR-407		-	-	-	-	-	K	-	-
KRF-V7030D	7	-	Y	-	-	-	-	-	-
KRF-V7030D-S		-	-	-	-	-	-	M	-
VR-407-S		-	-	-	-	-	K1	-	-
VR-409	9	-	-	-	-	-	K	-	-
KRF-V8030D		-	Y	-	-	-	-	-	-
KRF-V8030D-S	8	-	-	-	-	-	-	M	-
KRF-V8030D		-	-	-	-	-	-	-	-
KRF-V7030D	3	-	-	-	-	-	-	-	-
		-	-	-	-	-	-	-	-

L : Scandinavia

K : USA

P : Canada

R : Mexico

C : China

I : Malaysia

Y : PX(Far East,Hawaii)

T : England

E : Europe

G : Germany

V : China(Shanghai)

Y : AAFES(Europe)

X : Australia

Q : Russia

H : Korea

M : Other Areas

△ indicates safety critical components.

# KRF-V7030D/V8030D/VR-407/409

## SPECIFICATIONS

### For U.S.A and Canada

#### AUDIO section (VR-407)

Rated power output during STEREO operation

100 watts per channel minimum RMS, both channels driven, at 8  $\Omega$  from 20 Hz to 20 kHz with no more than 0.7% total harmonic distortion. (FTC)

Effective power output during SURROUND operation	
FRONT (20-20kHz-z/VR-407, 0.7% T.H.D. at 8 $\Omega$ one channel driven)	100 W + 100 W
CENTER (20-20kHz, 0.7% T.H.D. at 8 $\Omega$ one channel driven)	100 W
SURROUND (20-20kHz, 0.7% T.H.D. at 8 $\Omega$ one channel driven)	100 W + 100 W
Total harmonic distortion	0.055% (1 kHz, 50W, 8 $\Omega$ )
Frequency response	
CD	10 Hz ~ 53 kHz, +0 dB, -3.0 dB
Signal to noise ratio (IHF'66)	
PHONO (MM)	75 dB
CD	91 dB
Input sensitivity / impedance	
PHONO (MM)	2.5 mV / 27 k $\Omega$
CD	200 mV / 47 k $\Omega$
MONITOR IN	200 mV / 47 k $\Omega$
Output level / impedance	
TAPE REC	200 mV / 1 k $\Omega$
MONITOR OUT	200 mV / 1 k $\Omega$
PRE OUT (SUBWOOFER)	2 V / 2.2 k $\Omega$
Tone control	
BASS	$\pm 10$ dB (at 100 Hz)
TREBLE	$\pm 10$ dB (at 10 kHz)

#### DIGITAL AUDIO section

Sampling frequency	32 kHz, 44.1 kHz, 48 kHz, 96kHz
Input level / impedance / wave length	
Optical	(-15 dBm ~ -21 dBm), 660 nm $\pm 30$ nm
Coaxial	0.5 Vp-p / 75 $\Omega$

#### VIDEO section

VIDEO inputs / outputs	
VIDEO (composite)	1 Vp-p / 75 $\Omega$
S VIDEO (luminance signal)	1 Vp-p / 75 $\Omega$
(chrominance signal)	0.286 Vp-p / 75 $\Omega$

#### FM tuner section

Tuning frequency range	87.5 MHz ~ 108 MHz
Usable sensitivity (MONO)	1.6 $\mu$ V (75 $\Omega$ ) / 15.2 dBf (75 kHz DEV., SINAD 30 dB)
50dB quieting sensitivity	
STEREO	31.6 $\mu$ V (75 $\Omega$ ) / 41.2 dBf
Total harmonic distortion (1 kHz)	
MONO	0.6% (65 dBf input)
STEREO	0.7% (65 dBf input)
Signal to noise ratio (1 kHz, 75 kHz DEV.)	
MONO	75 dB (65 dBf input)
STEREO	68 dB (65 dBf input)
Stereo separation (1 kHz)	38 dB
Selectivity ( $\pm 400$ kHz)	70 dB
Frequency response	(30 Hz ~ 15kHz), +0.5 dB, -3.0 dB

#### AM tuner section

Tuning frequency range	
10 kHz step	530 kHz ~ 1,700 kHz
Usable sensitivity (30% mod., S/N 20 dB)	16 $\mu$ V / (600 $\mu$ V/m)
Signal to noise ratio (30% mod. 1 mV input)	50 dB

#### GENERAL

AC outlet	
SWITCHED	(total 150 W, 1.25 A max.)
Dimensions	W : 440 mm (17-5/16")
	H : 143 mm (5-5/8")
	D : 400 mm (15-3/4")
Weight (Net)	7.2 kg (15.8 lb)

### For other countries

#### AUDIO section (KRF-V7030D)

Effective power output during STEREO operation

1kHz, 10% T.H.D., at 8  $\Omega$  ..... 140 W + 140 W

Rated power output during STEREO operation

100 watts per channel minimum RMS, both channels driven, at 8  $\Omega$  from 40 Hz, 20Hz to 20 kHz with no more than 0.7% total harmonic distortion.(FTC)

Effective power output during SURROUND operation	
FRONT (1kHz, 10% T.H.D. at 8 $\Omega$ one channel driven)	140 W + 140 W
CENTER (1kHz, 10% T.H.D. at 8 $\Omega$ one channel driven)	140 W
SURROUND (1kHz, 10% T.H.D. at 8 $\Omega$ one channel driven)	140 W + 140 W
Total harmonic distortion	0.055% (1 kHz, 50W, 8 $\Omega$ )
Frequency response	
CD	10 Hz ~ 50 kHz, +0 dB, -3.0 dB
Signal to noise ratio (IHF'66)	
PHONO (MM)	75 dB
CD	91 dB
Input sensitivity / impedance	
PHONO (MM)	2.5 mV / 27 k $\Omega$
CD	200 mV / 47 k $\Omega$
MONITOR IN	200 mV / 47 k $\Omega$
Output level / impedance	
TAPE REC	200 mV / 1 k $\Omega$
MONITOR OUT	200 mV / 1 k $\Omega$
PRE OUT (SUBWOOFER)	2 V / 2.2 k $\Omega$
Tone control	
BASS (For Australia and U.S-Military)	$\pm 10$ dB (at 100 Hz)
BASS (Other countries)	$\pm 10$ dB (at 60 Hz)
TREBLE	$\pm 10$ dB (at 10 kHz)

#### DIGITAL AUDIO section

Sampling frequency	32 kHz, 44.1 kHz, 48 kHz, 96kHz
Input level / impedance / wave length	
Optical	(-15 dBm ~ -21 dBm), 660 nm $\pm 30$ nm
Coaxial	0.5 Vp-p / 75 $\Omega$

#### VIDEO section

VIDEO inputs / outputs	
VIDEO (composite)	1 Vp-p / 75 $\Omega$
S VIDEO (luminance signal)	1 Vp-p / 75 $\Omega$
(chrominance signal)	0.286 Vp-p / 75 $\Omega$

#### FM tuner section

Tuning frequency range	87.5 MHz ~ 108 MHz
Usable sensitivity (MONO)	1.6 $\mu$ V (75 $\Omega$ ) / 15.2 dBf (75 kHz DEV., SINAD 30 dB)
50dB quieting sensitivity	
STEREO	31.6 $\mu$ V (75 $\Omega$ ) / 41.2 dBf
Total harmonic distortion (1 kHz)	
MONO	0.6% (65 dBf input)
STEREO	0.7% (65 dBf input)
Signal to noise ratio (1 kHz, 75 kHz DEV.)	
MONO	75 dB (65 dBf input)
STEREO	68 dB (65 dBf input)
Stereo separation (1 kHz)	38 dB
Selectivity ( $\pm 400$ kHz)	50 dB
Frequency response	(30 Hz ~ 15kHz), +0.5 dB, -3.0 dB

#### AM tuner section

Tuning frequency range	
9 kHz step	531 kHz ~ 1,602 kHz
10 kHz step	530 kHz ~ 1,610 kHz
Usable sensitivity	16 $\mu$ V / (600 $\mu$ V/m)
Signal to noise ratio (30% mod. 1 mV input)	50 dB

#### GENERAL

Power consumption	
AC outlet	
SWITCHED	(total 90 W max.)
Dimensions	W : 440 mm
	H : 143 mm
	D : 400 mm
Weight (Net)	7.4 kg

#### Notes

1. KENWOOD follows a policy of continuous advancements in development. For this reason specifications may be changed without notice.
2. The full performance may not be exhibited in an extremely cold location (under a water-freezing temperature).

# KRF-V7030D/V8030D/VR-407/409

## SPECIFICATIONS

For U.S.A and Canada (VR-409)

### AUDIO section

Rated power output during STEREO operation

100 watts per channel minimum RMS, both channels driven, at 8 Ω from 20 Hz to 20 kHz with no more than 0.7% total harmonic distortion. (FTC)

Effective power output during SURROUND operation

FRONT (20-20kHz, 0.7% T.H.D. at 8 Ω, one channel driven)	100 W + 100 W
CENTER (20-20kHz, 0.7% T.H.D. at 8 Ω, one channel driven)	100 W
SURROUND (20-20kHz, 0.7% T.H.D. at 8 Ω, one channel driven)	100 W + 100 W
Total harmonic distortion	0.055% (1 kHz, 50W, 8 Ω)
Frequency response	CD ..... 10 Hz ~ 53 kHz, +0 dB, -3.0 dB
Signal to noise ratio (IHF'66)	PHONO (MM) ..... 75 dB
CD ..... 91 dB	Input sensitivity / impedance
PHONO (MM) ..... 75 dB	PHONO (MM) ..... 2.5 mV / 27 kΩ
CD ..... 91 dB	CD ..... 200 mV / 47 kΩ
Input sensitivity / impedance	Output level / impedance
PHONO (MM) ..... 2.5 mV / 27 kΩ	TAPE REC ..... 200 mV / 1 kΩ
CD ..... 200 mV / 47 kΩ	PRE OUT (SUBWOOFER) ..... 2 V / 2.2 kΩ
Output level / impedance	Tone control
TAPE REC ..... 200 mV / 1 kΩ	BASS ..... ±10 dB (at 100 Hz)
PRE OUT (SUBWOOFER) ..... 2 V / 2.2 kΩ	TREBLE ..... ±10 dB (at 10 kHz)

### DIGITAL AUDIO section

Sampling frequency	32 kHz, 44.1 kHz, 48 kHz, 96kHz
Input level / impedance / wave length	Optical ..... (-15 dBm ~ -21 dBm), 660 nm ±30nm
Coaxial ..... 0.5 Vp-p / 75 Ω	

### VIDEO section

VIDEO inputs / outputs	VIDEO (composite) ..... 1 Vp-p / 75 Ω
S VIDEO (luminance signal)	1 Vp-p / 75 Ω
(chrominance signal)	0.286 Vp-p / 75 Ω

### FM tuner section

Tuning frequency range	87.5 MHz ~ 108 MHz
Usable sensitivity (MONO)	1.6 μV (75 Ω) / 15.2 dBf (75 kHz DEV., SINAD 30 dB)
50dB quieting sensitivity	STEREO ..... 31.6 μV (75 Ω) / 41.2 dBf
Total harmonic distortion (1 kHz)	MONO ..... 0.6% (65 dBf input)
STEREO ..... 0.7% (65 dBf input)	Signal to noise ratio (1 kHz, 75 kHz DEV.)
MONO ..... 75 dB (65 dBf input)	STEREO ..... 68 dB (65 dBf input)
STEREO ..... 68 dB (65 dBf input)	Stereo separation (1 kHz) ..... 38 dB
Stereo separation (1 kHz) ..... 38 dB	Selectivity (±400 kHz) ..... 70 dB
Selectivity (±400 kHz) ..... 70 dB	Frequency response ..... (30 Hz ~ 15kHz), +0.5 dB, -3.0 dB
Frequency response ..... (30 Hz ~ 15kHz), +0.5 dB, -3.0 dB	

### AM tuner section

Tuning frequency range	10 kHz step ..... 530 kHz ~ 1,700 kHz
Usable sensitivity (30% mod., S/N 20 dB)	16 μV / (600 μV/m)
Signal to noise ratio (30% mod. 1 mV input)	50 dB

### GENERAL

Power consumption	2.6 A
AC outlet	SWITCHED ..... (total 150 W, 1.25 A max.)
Dimensions	W : 440 mm (17-5/16")
H : 143 mm (5-5/8")	D : 400 mm (15-3/4")
Weight (Net)	7.4 kg (15.8 lb)

### Notes

1. KENWOOD follows a policy of continuous advancements in development. For this reason specifications may be changed without notice.
2. The full performance may not be exhibited in an extremely cold location (under a water-freezing temperature).

### Note:

Component and circuit are subject to modification to insure best operation under differing local conditions. This manual is based on Europe (E) standard, and provides information on regional circuit modification through use of alternate schematic diagrams, and information on regional component variations through use of parts list.

## KENWOOD CORPORATION

14-6,Dogenzaka 1-chome, Shibuya-ku, Tokyo, 150-8501 Japan

For other countries (KRF-V8030D)

### AUDIO section

Effective power output during STEREO operation

1kHz,10% T.H.D.,at 8 Ω .....140 W + 140 W

Rated power output during STEREO operation

100 watts per channel minimum RMS, both channels driven, at 8 Ω from 20 Hz to 20 kHz with no more than 0.7% total harmonic distortion.(FTC)

Effective power output during SURROUND operation

FRONT (1kHz, 10% T.H.D. at 8 Ω, one channel driven)	140 W + 140 W
CENTER (1kHz, 10% T.H.D. at 8 Ω, one channel driven)	140 W
SURROUND (1kHz, 10% T.H.D. at 8 Ω, one channel driven)	140 W + 140 W
Total harmonic distortion	0.055% (1 kHz, 50W, 8 Ω)
Frequency response	CD ..... 10 Hz ~ 53 kHz, +0 dB, -3.0 dB
Signal to noise ratio (IHF'66)	PHONO (MM) ..... 75 dB
CD ..... 91 dB	Input sensitivity / impedance
PHONO (MM) ..... 75 dB	PHONO (MM) ..... 2.5 mV / 27 kΩ
CD ..... 91 dB	CD ..... 200 mV / 47 kΩ
Input sensitivity / impedance	Output level / impedance
PHONO (MM) ..... 2.5 mV / 27 kΩ	TAPE REC ..... 200 mV / 1 kΩ
CD ..... 200 mV / 47 kΩ	PRE OUT (SUBWOOFER) ..... 2 V / 2.2 kΩ
Output level / impedance	Tone control
TAPE REC ..... 200 mV / 1 kΩ	BASS (For Australia and U.S-Military) ..... ±10 dB (at 100 Hz)
PRE OUT (SUBWOOFER) ..... 2 V / 2.2 kΩ	BASS (Other countries) ..... ±10 dB (at 60 Hz)
Tone control	TREBLE ..... ±10 dB (at 10 kHz)
BASS (For Australia and U.S-Military) ..... ±10 dB (at 100 Hz)	
BASS (Other countries) ..... ±10 dB (at 60 Hz)	
TREBLE ..... ±10 dB (at 10 kHz)	

### DIGITAL AUDIO section

Sampling frequency	32 kHz, 44.1 kHz, 48 kHz, 96kHz
Input level / impedance / wave length	Optical ..... (-15 dBm ~ -21 dBm), 660 nm ±30nm
Coaxial ..... 0.5 Vp-p / 75 Ω	

### VIDEO section

VIDEO inputs / outputs	VIDEO (composite) ..... 1 Vp-p / 75 Ω
S VIDEO (luminance signal)	1 Vp-p / 75 Ω
(chrominance signal)	0.286 Vp-p / 75 Ω

### FM tuner section

Tuning frequency range	87.5 MHz ~ 108 MHz
Usable sensitivity (MONO)	1.6 μV (75 Ω) / 15.2 dBf (75 kHz DEV., SINAD 30 dB)
50dB quieting sensitivity	STEREO ..... 31.6 μV (75 Ω) / 41.2 dBf
Total harmonic distortion (1 kHz)	MONO ..... 0.6% (65 dBf input)
STEREO ..... 0.7% (65 dBf input)	Signal to noise ratio (1 kHz, 75 kHz DEV.)
MONO ..... 75 dB (65 dBf input)	STEREO ..... 68 dB (65 dBf input)
STEREO ..... 68 dB (65 dBf input)	Stereo separation (1 kHz) ..... 38 dB
Stereo separation (1 kHz) ..... 38 dB	Selectivity (±400 kHz) ..... 50 dB
Selectivity (±400 kHz) ..... 50 dB	Frequency response ..... (30 Hz ~ 15kHz), +0.5 dB, -3.0 dB
Frequency response ..... (30 Hz ~ 15kHz), +0.5 dB, -3.0 dB	

### AM tuner section

Tuning frequency range	10 kHz step ..... 531 kHz ~ 1,602 kHz
Usable sensitivity (30% mod., S/N 20 dB)	16 μV / (600 μV/m)
Signal to noise ratio (30% mod. 1 mV input)	70 dB

### GENERAL

Power consumption	250 W
AC outlet	SWITCHED ..... (total 90 W max.)
Dimensions	W : 440 mm
H : 143 mm	D : 400 mm
Weight (Net)	7.4 kg

## KENWOOD SERVICE CORPORATION

P.O BOX 22745, 2201 East Dominguez St., Long Beach, CA 90801-5745, U.S.A.