

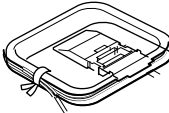





CONTENTS / ACCESSORIES

Contents

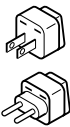
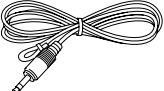
CONTENTS / ACCESSORIES	2	PC BOARD	9
DISASSEMBLY FOR REPAIR	3	SCHEMATIC DIAGRAM	22
BLOCK DIAGRAM	5	EXPLODED VIEW	53
ADJUSTMENT	6	PARTS LIST	55
WIRING DIAGRAM	8	SPECIFICATIONS	69

Accessories

<p>Remote control unit (A70-1453-05): RC-R0913...KP1K1P2 (A70-1454-05): RC-R0914...M1X1Y1V (A70-1455-05): RC-0915.....E1E2</p>	<p>Batteries</p> 	<p>AM Loop Antenna (T90-0852-05)</p> 	<p>FM Antenna (T90-0855-05)</p> 
 Battery cover(A09-1166-08)			
<p>AC plug adaptor *..... (1)</p>  <p>Use to adapt the plug on the power cord to the shape of the wall outlet. (Accessory only for regions where use is necessary.)</p>	<p>Antenna ass'y (T90-0850-15) U.S.A. only</p> 		
<p>* Refer to parts list.</p>			

	
<p>Manufactured under license from Dolby Laboratories. Dolby , Pro Logic , AC-3 , and the double-D symbol are trademarks of Dolby Laboratories. Confidential Unpublished Works. ' 1992-1997 Dolby Laboratories. All rights reserved.</p>	
	
<p>Manufactured under license from Digital Theater Systems, Inc. US Pat. No. 5,451,942 and other worldwide patents issues and pending. DTS and DTS Digital Surround are trademarks of Digital Theater Systems, Inc. ' 1996 Digital Theater Systems, Inc. All rights reserved.</p>	



<p> , HDCD^α, High Definition Compatible Digital^α and Pacific Microsonics™ are either registered trademarks or trademarks of Pacific Microsonics, Inc. in the United States and/or other countries. HDCD system manufactured under license from Pacific Microsonics, Inc. This product is covered by one or more of the following: IN the USA: 5,479,168, 5,638,074, 5,640,161, 5,808,574, 5,838,274, 5,854,600, 5,864,311, 5,872,531, and in Australia: 669114. Other patents pending.</p>

DISASSEMBLY FOR REPAIR

How to Remove the Front Panel

1. How to Remove the Front Panel

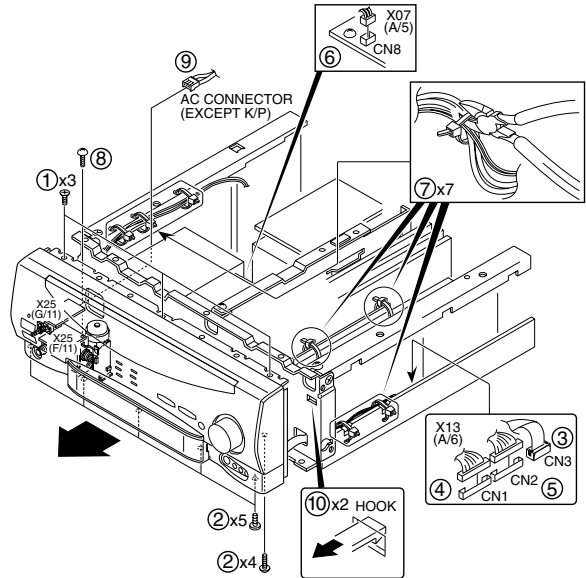
1. Remove the screws (①X3) on top of the panel.
2. Remove the screws (②X9) located at the bottom of the panel.
3. Disconnect the cable (③) and connectors (④,⑤) on the X13 A/6.
4. Disconnect the connector (⑥) on the X07 A/5.
5. Cut the tie band (⑦X7) as shown in the figure.
6. Remove the screw (⑧X1) on the X25 F/11.
7. Disconnect the connector (⑨) on the X25 G/11.(Except K/P type)
8. Remove the hooks (⑩X2) on the sub panel.
9. Remove the front panel in the direction of arrow.



Disassembling the Rear Panel and How to Replace the Power Transistor

1. Disconnect the CN10 on the X07 C/5.
2. Remove all of screws (①X61) and digital caps (②X8) on the rear panel.
(The number of screws and caps are vary according to the models).
3. Disconnect the cable CN16 (③) on the X13 A/6.
4. Disconnect the flexible cables CN101(④) on the X25 C/11, CN102 (⑤) and * CN103 (⑥)on the X25 B/11.
* (K/P type only).
5. Remove the rear panel in the direction of arrow.
6. Remove the screw (⑦), then remove the X25 B/11.

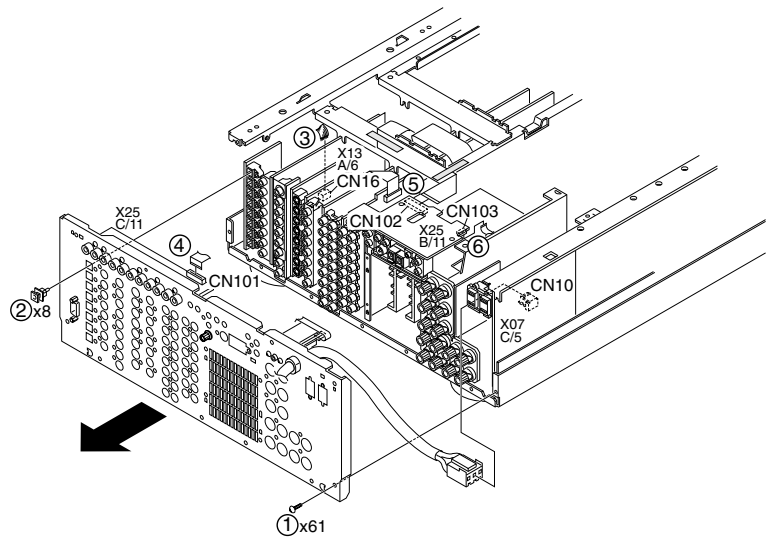

7. To remove the tuner unit, disconnect the CN1 (⑧) and remove a screw (⑨).
8. Remove the screws (⑩X9) on the frames (A/B/C), push rivet (⑪) and PC support (⑫x2) on the X11 A/2.

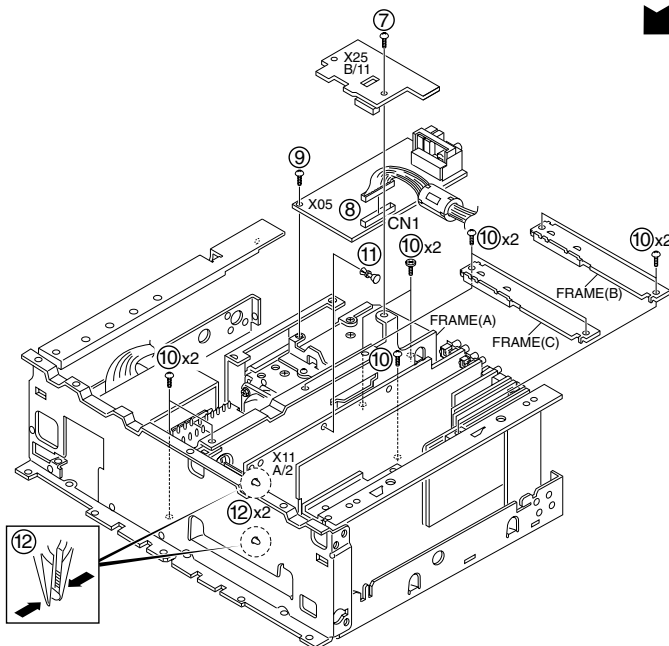

KRF-X7775D/X7775D-S/VR-5080/5090

DISASSEMBLY FOR REPAIR

- To remove the frame A rearward, cut the tie bands (13X4) on the frames.
- Remove a screw (14), then remove a thermostat.

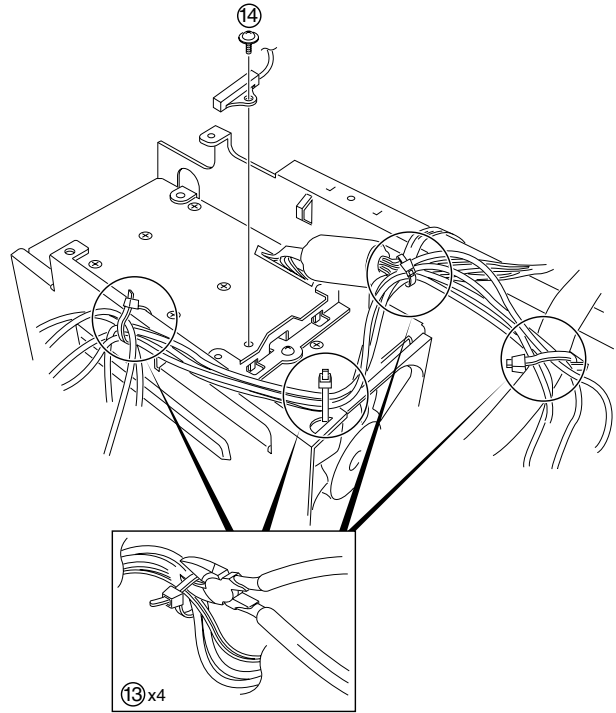

- Remove the screws (15X8), then remove a frame (D), and X07 B/5.
- To remove a power amplifier unit (X07 A/5), remove the screws (16x4), and a PC support (17x2).
- Set up the X07 A/5 in the direction of arrow as shown in the figure.
- Replace the defective transistor.

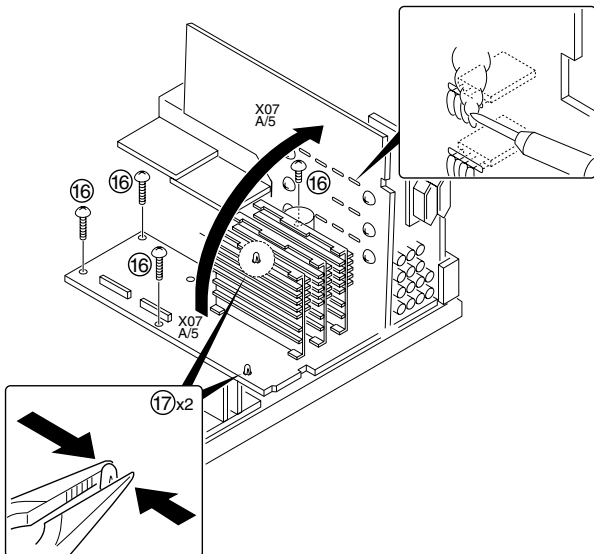
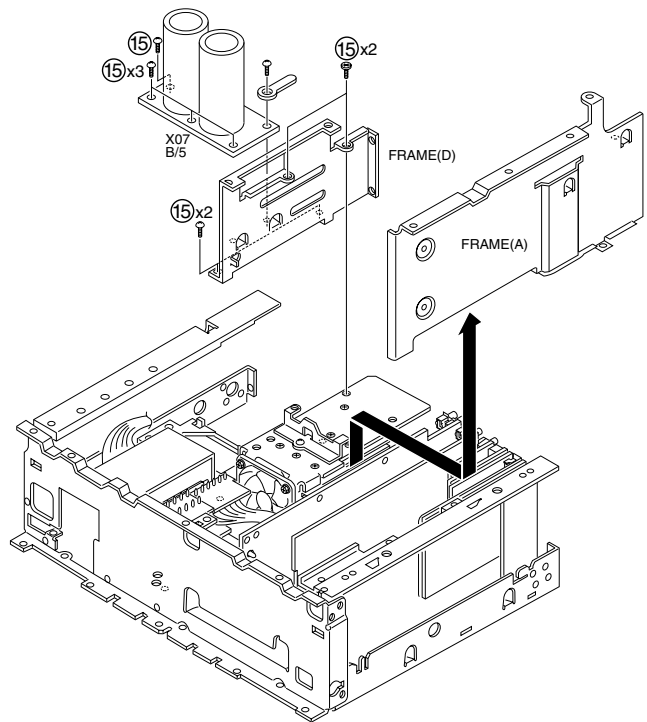

KRF-X7775D/X7775D-S/VR-5080/5090

BLOCK DIAGRAM

VIDEO SECTION

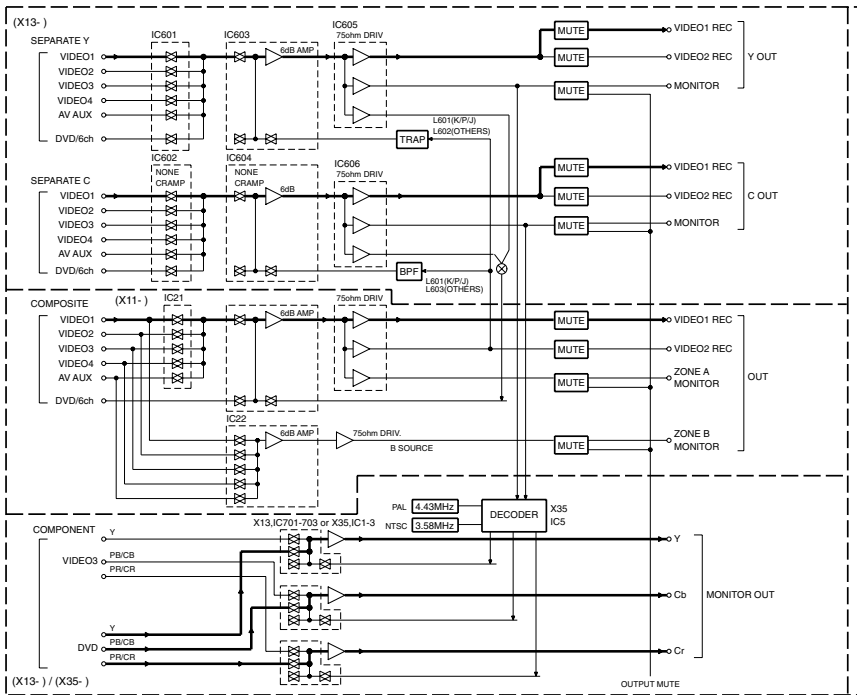

(X13-) / (X35-)

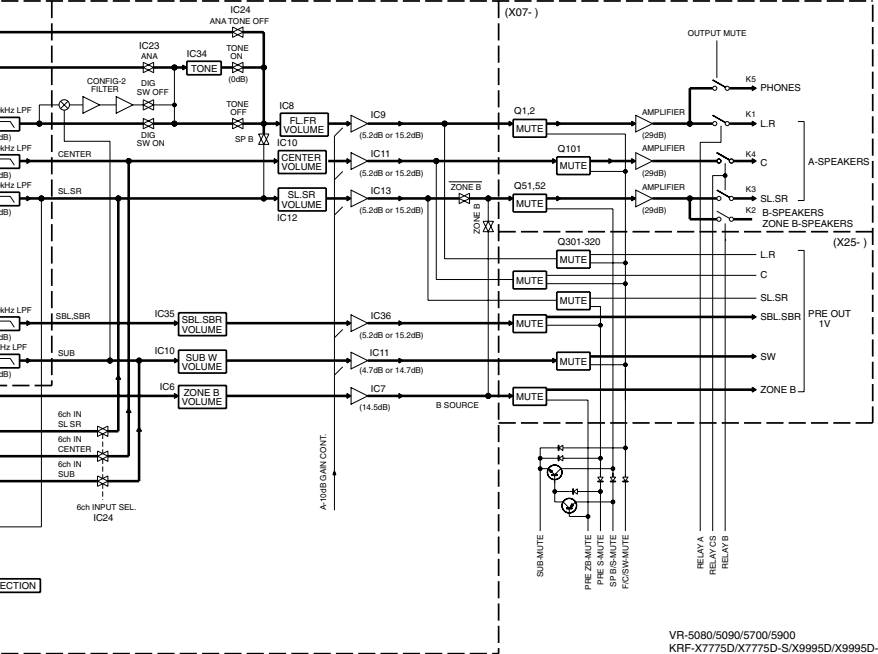
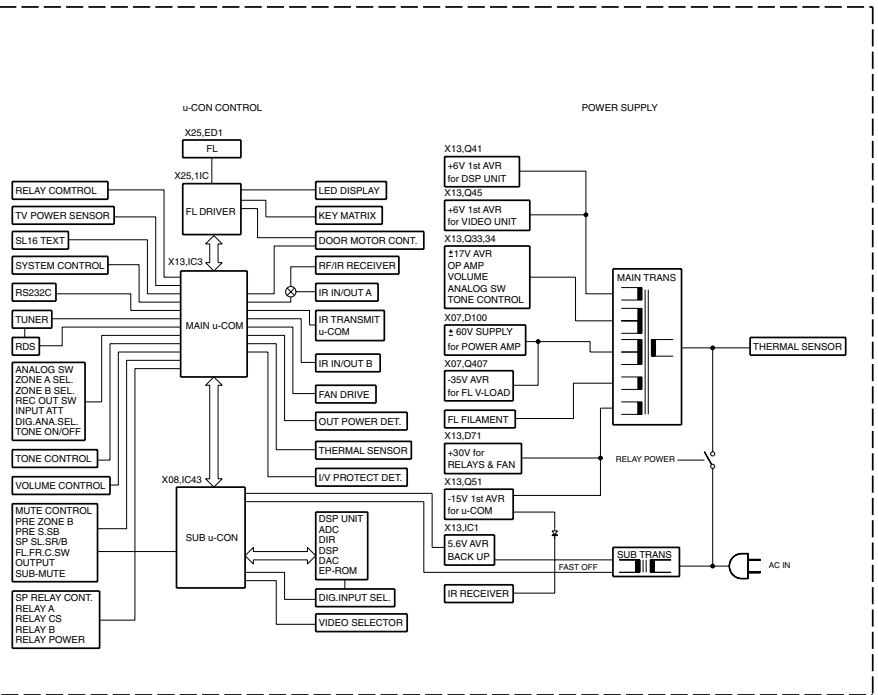
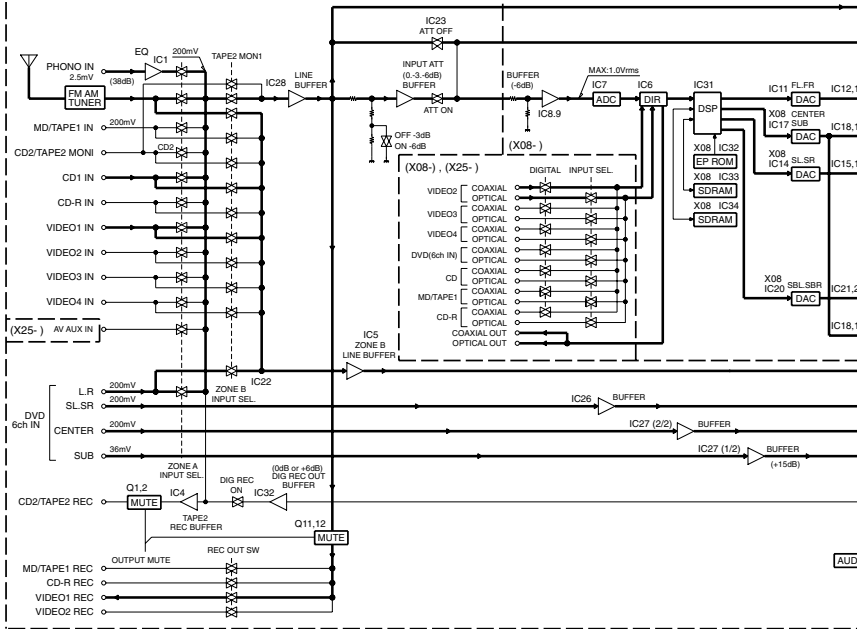

VR-5080/5090/5000
KRF-X7775D/X7775D-S/X9995D/X9995D-S

CIRCUIT DESCRIPTION

1. Initialization

1-1 The Initial Setting

- Insert the power cord to AC wall outlet by pressing the "ON/STANDBY" key.

2. Destination List of Tuner

0 : Pull down, 1: Pull up

SET TYPE	TYPE	BAND	RECEIVING FREQUENCY RANGE	CHANNEL SPACE	IF	PLL
K, P, R	K1 1700	FM	87.5MHz-108.0MHz	100kHz	+10.7MHz	25kHz
		AM	530kHz-1700kHz	10kHz	+450kHz	10kHz
Y, M, I, C, V	K2 1610	FM	87.5MHz-108.0MHz	100kHz	+10.7MHz	25kHz
		AM	530kHz-1610kHz	10kHz	+450kHz	10kHz
K, P	K4 1700 RBDS	FM	87.5MHz-108.0MHz	100kHz	+10.7MHz	25kHz
		AM	530kHz-1700kHz	10kHz	+450kHz	10kHz
Y, M, I, C, V, E, X, H	E1	FM	87.5MHz-108.0MHz	50kHz	+10.7MHz	25kHz
		AM	531kHz-1602kHz	9kHz	+450kHz	9kHz
E, T	E3 RDS	FM	87.5MHz-108.0MHz	50kHz	+10.7MHz	25kHz
		AM	531kHz-1602kHz	9kHz	+450kHz	9kHz

3. Conditions according to the models or destination

3-1 Distinction of Destination

: u-com (X13,IC3) Port 54

Type	Voltage : Max 5.0V
K2	0~0.52
K1	1.61~2.49
K4(RBDS)	2.51~3.39
E3(RDS)	3.41~4.45
E1	4.47~5.00

3-2 Distinction of Models : u-com (X13,IC3) Port 53

Models	*	Voltage : Max 5.0V
VR-5080	NO	0~0.37
VR-5090	YES	0.39~1.10
VR-5700	YES	1.12~1.84
VR-5900-S	YES	1.86~2.49
KRF-X9995D/D-S	YES	2.51~3.14
KRF-X7775D/D-S	YES	3.16~3.88
KRF-X9995D-S (M/X TYPE)	NO	3.90~4.61
KRF-X7775D-S (M/X/V TYPE)	NO	4.63~5.00

* Switching of RF or Front IR and Rear IR Receiver Terminal.

4. Tuner Preset Memory

P.ch	K1	K2	K4	E1	E3	P.ch	K1	K2	K4	E1	E3
1	FM 98.3M	FM 98.3M	FM 98.3M	FM 98.3M	FM 98.3M	21	AM 530K	AM 530K	AM 530K	AM 531K	AM 531K
2	FM 87.5M	FM 87.5M	FM 87.5M	FM 87.5M	FM 87.5M	22	FM 87.5M	FM 87.5M	FM 87.5M	FM 87.5M	FM 87.5M
3	FM 89.1M	FM 89.1M	FM 89.1M	FM 89.1M	FM 89.1M	23	FM 87.5M	FM 87.5M	FM 87.5M	FM 87.5M	FM 87.5M
4	FM 108.0M	FM 108.0M	FM 108.0M	FM 108.0M	FM 108.0M	24	FM 87.5M	FM 87.5M	FM 87.5M	FM 87.5M	FM 87.5M
5	FM 90.0M	FM 90.0M	FM 90.0M	FM 90.0M	FM 90.0M	25	FM 87.5M	FM 87.5M	FM 87.5M	FM 87.5M	FM 87.5M
6	FM 87.5M	FM 87.5M	FM 87.5M	FM 87.5M	FM 87.5M	26	FM 87.5M	FM 87.5M	FM 87.5M	FM 87.5M	FM 87.5M
7	FM 87.5M	FM 87.5M	FM 87.5M	FM 87.5M	FM 87.5M	27	FM 87.5M	FM 87.5M	FM 87.5M	FM 87.5M	FM 87.5M
8	AM 1610K	FM 87.5M	AM 1610K	FM 87.5M	FM 87.5M	28	FM 87.5M	FM 87.5M	FM 87.5M	FM 87.5M	FM 87.5M
9	AM 1700K	AM 1610K	AM 1700K	AM 1602K	AM 1602K	29	FM 87.5M	FM 87.5M	FM 87.5M	FM 87.5M	FM 87.5M
10	AM 1000K	AM 1000K	AM 1000K	AM 999K	AM 999K	30	FM 106.0M	FM 106.0M	FM 106.0M	FM 106.0M	FM 106.0M
11	AM 630K	AM 630K	AM 630K	AM 630K	AM 630K	31	FM 87.5M	FM 87.5M	FM 87.5M	FM 87.5M	FM 87.5M
12	AM 1440K	AM 1440K	AM 1440K	AM 1440K	AM 1440K	32	FM 87.5M	FM 87.5M	FM 87.5M	FM 87.5M	FM 87.5M
13	FM 106.0M	FM 106.0M	FM 106.0M	FM 106.0M	FM 106.0M	33	FM 87.5M	FM 87.5M	FM 87.5M	FM 87.5M	FM 87.5M
14	AM 530K	AM 530K	AM 530K	AM 531K	AM 531K	34	FM 87.5M	FM 87.5M	FM 87.5M	FM 87.5M	FM 87.5M
15	FM 87.5M	FM 87.5M	FM 87.5M	FM 87.5M	FM 87.5M	35	FM 87.5M	FM 87.5M	FM 87.5M	FM 87.5M	FM 87.5M
16	FM 98.0M	FM 98.0M	FM 98.0M	FM 98.0M	FM 98.0M	36	FM 87.5M	FM 87.5M	FM 87.5M	FM 87.5M	FM 87.5M
17	FM 98.5M	FM 98.5M	FM 98.5M	FM 98.5M	FM 98.5M	37	FM 87.5M	FM 87.5M	FM 87.5M	FM 87.5M	FM 87.5M
18	FM 87.5M	FM 87.5M	FM 87.5M	FM 87.5M	FM 87.5M	38	FM 87.5M	FM 87.5M	FM 87.5M	FM 87.5M	FM 87.5M
19	AM 990K	AM 990K	AM 990K	AM 990K	AM 990K	39	FM 108.0M	FM 108.0M	FM 108.0M	FM 108.0M	FM 108.0M
20	FM 97.4M	FM 97.4M	FM 97.4M	FM 97.7M	FM 97.7M	40	AM 1000K	AM 1000K	AM 1000K	AM 945K	AM 945K

CIRCUIT DESCRIPTION

5. Test Mode

5-1 Setting Method of the Test Mode

•Turn on the power supply while pressing the "INPUT SELECTOR DOWN" key, to make a set in test mode.

5-2 Canceling the Test Mode

•The system is initialized and the test mode is cancelled if unplug the AC power cord from an AC power wall outlet.

5-3 Contents of the Test Mode

* The following operation is available when the FL is all lighting up mode only.

Key	Operation	Display
SOUND	Set up the RF frequency to 428MHz.	RF BAND
LISTEN MODE	Set up the RF frequency to 422MHz.	RF BAND
THX	Indicated the tuner destination in the FL.	EX. TYPE E1
MEMORY	Changed the dimmer off/1/2 cyclically.	ALL FL Light ON

6. Main Microcomputer: uPD784217A516 (X13, IC3)

6-1 Main Microcomputer Periphery block diagram

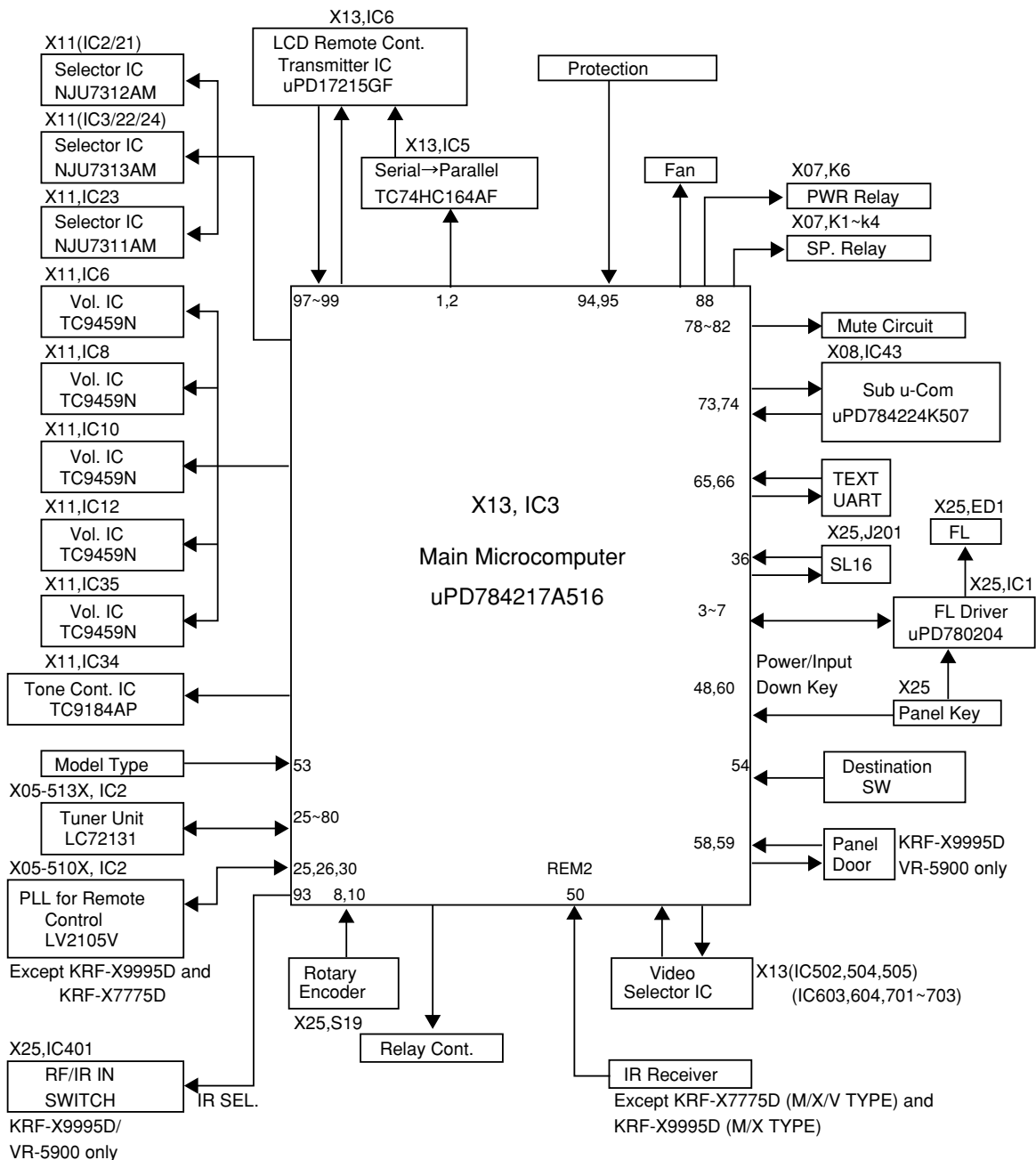

CIRCUIT DESCRIPTION

6-2 Port Description of Main Microcomputer : uPD784217A516 (X13, IC3)

Port No.	Port Name	I/O	Function
1	REM DA	O	IR transmitter IC(X13,IC5) control data output.
2	REM CK	O	IR transmitter IC(X13,IC5) control clock output.
3	FL CLK	O	Clock output to FL driver.
4	FL DIN	I	Data input from FL driver.
5	FL DOUT	O	Data output to FL driver.
6	FL STB	O	Strobe output to FL driver.
7	FL RST	O	Reset output to FL driver.
8	ENC B	I	Input port of volume encoder.
9	VDD	-	+5V power supply.
10	ENC A	I	Input port of volume encoder.
11	SEL CLK	O	Clock output to selector IC.
12	SEL DATA	O	Data output to selector IC.
13~15	SEL STB1~3	O	Strobe (1~3) output to selector IC.
16	TONE CLK	O	Clock output to tone control / selector IC.
17	TONE DATA	O	Data output to tone control / selector IC.
18	TONE STB	O	Strobe output to tone control IC.
19	VOL CLK	O	Clock output to volume IC.
20	VOL DATA	O	Data output to volume IC.
21	VOL STB2	O	Strobe 2 output to volume IC.
22	TEST/VPP	-	Connected to GND.
23	STEREO	I	Tuner stereo signal detection port.
24	SD	I	Tuner SD signal detection port.
25	RF PLL CLK	O	Clock output to PLL (LC72131) IC. * Clock output to PLL IC (LV2105V) for RF remote controller. * Except KRF-X7775D/9995D
26	RF PLL DATA	O	Data output to PLL(LC72131) IC. * Data output to PLL IC (LV2105V) for RF remote controller. * Except KRF-X7775D/9995D
27	PLL DO	I	Data input from PLL (LC72131)IC.
28	PLL CE	O	Chip enable to PLL (LC72131) IC.
29	T MUTE	O	Mute control to tuner.
30	RF PLL CE	O	PLL (LV2105V)CE for RF remote controller. (VR series only)
31~33	P MACRO A~C	O	Output port for perfect macro (A~C). (Refer to 7-6)
34	TV SENS	I	Detection port of TV signal. (Refer to 7-7)
35	VOL STB1	O	Strobe 1 output to volume IC.
36	S DATA	I/O	SL16 data input/output.
37	VDD	-	+5V power supply
38	X2	-	Crystal resonator (12.5MHz) connection.
39	X1	-	Crystal resonator (12.5MHz) connection.
40	VSS	-	Connected to GND.
41	XT2	-	Unused.
42	XT1	-	Unused.
43	RESET	I	Reset signal input for main microcomputer.
44	CE	I	Detection port of chip enable.
45	S BUSY	I/O	Busy signal input/output.
46	232C DET	I	Detection port of RS232C communication. (Except KRF-X7775D)
47	RDS CLK	I	Clock input of RDS demodulator IC. (E/T type only)
48	POWER KEY IN	I	Detection port for power key.
49	REM1	I	Remote control signal input 1 (front panel).
50	REM2	I	Remote control signal input 2 (IR receiver). Except KRF-X7775D (X/M/V)and KRF-X9995D (M/X)

CIRCUIT DESCRIPTION

Port No.	Port Name	I/O	Function
51	VDD	-	+5V power supply
52	AVREF	-	Reference voltage input.
53	MODEL SEL	I	Discrimination port for model type.
54	DSW0	I	Detection port for tuner destination SW 0.
55	THERM SW	I	Detection port for thermal switch. (Refer to 7-1)
56	S LEVEL	I	RDS signal level input. (E/T type only)
57	RDS DATA	I	Data input of RDS demodulator IC. (E/T type only)
58	CLOSE SENS	I	Detection port of close sensor for panel door. (Refer to 7-3) (KRF-X9995D/VR-5900 only)
59	OPEN SENS	I	Detection port of open sensor for panel door. (Refer to 7-3) (KRF-X9995D/VR5900 only)
60	INPUT DOWN KEY IN	I	Detection port of input down key.
61	AVSS	-	Connected to GND.
62	P MACRO IN	I	Input port of perfect macro. (Refer to 7-7)
63	RELAY CONT	O	Relay control output. (Refer to 7-4)
64	AVREF1	-	Reference voltage input.
65	1394/TEXT RX	I	CD TEXT UTRA communication data input.
66	1394/TEXT TX	O	CD TEXT UTRA communication data output.
67	SUB RESET	O	Reset signal output to sub microcomputer.
68	RS RX1	I	RS232C communication data input 1. (Except KRF-X7775D)
69	RS TX1	O	RS232C communication data output 1. (Ditto)
70	RS RX2	I	RS232C communication data input 2. (Ditto)
71	RS TX2	O	RS232C communication data output 2. (Ditto)
72	LED	O	Control port for pro logic2 led.
73	SDT	I	Communication data input from sub microcomputer.
74	MDT	O	Communication data output to sub microcomputer.
75	MCK	O	Clock output to sub microcomputer.
76	MREQ	O	Communication master request.
77	SREQ	I	Communication slave request.
78	F/CSW MUTE	O	Mute control port for room A.
79	PRE S/B MUTE	O	Mute control port for pre out surround.
80	SP S/B MUTE	O	Mute control port for S/B speakers.
81	PRE ZB MUTE	O	Mute control port for pre out B (zone B).
82	V/RECMUTE	O	Mute control port for video rec out.
83	10dB GAIN	O	Switching port for +10dB amplifier.
84	RELAY CS	O	Mute control port for center/surround speakers.
85	RELAY B	O	Relay control port for speaker B.
86	RELAY A	O	Relay control port for speaker A.
87	RELAY TR	O	Switching port for transformer tap.
88	POWER	O	Power relay control port.
* 89	FAN H/L	O	Control port for fan motor (H/L).
* 90	FAN ON/OFF	O	Control port for fan motor (on/off).
* 91	10W	I	10W detection port for fan control.
* 92	1W	I	1W detection port for fan control.
93	IR SELECT	O	RF/IR IN switch control. (Refer to 7-5), KRF-X9995D/VR-5900 only
94	V PROT	I	Detection port of protection signal.
95	I PROT	I	Detection port of protection signal.
96	STBY LED	O	Control port for standby led.
97	REM RWR	I	RWR from LCD remote controller.
98	REM ENB	I	Chip enable from LCD remote controller.
99	REM REQ	O	Request to LCD remote controller.
100	VSS	-	GND

* Refer to 7-1

CIRCUIT DESCRIPTION

7. Description of the Circuit Control

7-1 Fan Control (X13,IC3)

Fan	10W(91Pin)	1W(92Pin)	THERMAL SW(55Pin)	FAN ON/OFF(90Pin)	FAN H/L(89Pin)
FAN STOP	H	H	L	0	1
FAN LOW SPEED	H	L	L	1	1
FAN HI SPEED	L	L	L	1	0
FAN LOW SPEED	H	H	H	1	1
	H	L	H	1	1
FAN HI SPEED	L	L	H	1	0

7-2 Door Open/Close Control : FL Driver(X25,IC1)

KRF-X9995D/VR-5900 only

	DOOR OUT1(42Pin)	DOOR OUT2(41Pin)
OPEN	1	0
CLOSE	0	1
STOP	0	0
BREAK	1	1

7-3 Open Close Sensor(X13,IC3 : Main u-com)

KRF-X9995D/VR-5900 only

	OPEN SENS(59Pin)	CLOSE SENS(58Pin)
END OF OPEN ACTION	0	1
END OF CLOSE ACTION	1	0

7-4 Relay Control : X13,IC3(Main u-com)

SELECTOR	RELAY CONT.(63Pin)
PHONO	0
TUNER	
CD1	
MD/TAPE1	
CD-R	
CD2/TAPE2 MONITOR	1
VIDEO1	
VIDEO2	
VIDEO3	
VIDEO4	
DVD	
AV/AUX	

7-5 IR Remote Control

		X25,IC401 RF IN (7Pin)	X25,IC401 IR IN (6Pin)	IR SELECT X13,IC3 (93Pin)
WITH RF VERSION	RF ON	X	O	0
	RF OFF	O	X	1
WITHOUT RF VERSION	FRONT IR ON	X	O	0
	FRONT IR OFF	O	X	1

7-6 P Macro Video Switch(X13,IC505)

SELECTOR	P MACRO A(3Pin)	P Macro B(4Pin)	P Macro C(5Pin)
VIDEO1	0	0	0
VIDEO2	0	1	0
VIDEO3	1	0	0
VIDEO4	1	1	0
DVD	0	0	1

7-7 Video/TV Detection : X13,IC3

Video Detection

Video Signal	P Macro IN(62Pin)
Yes	H
No	L

TV Detection

TV POWER	TV SENS.(34Pin)
ON	H
OFF	L

8. Sub microcomputer: uPD784224K507(X08, IC43)

8-1 Sub microcomputerperiphery block diagram

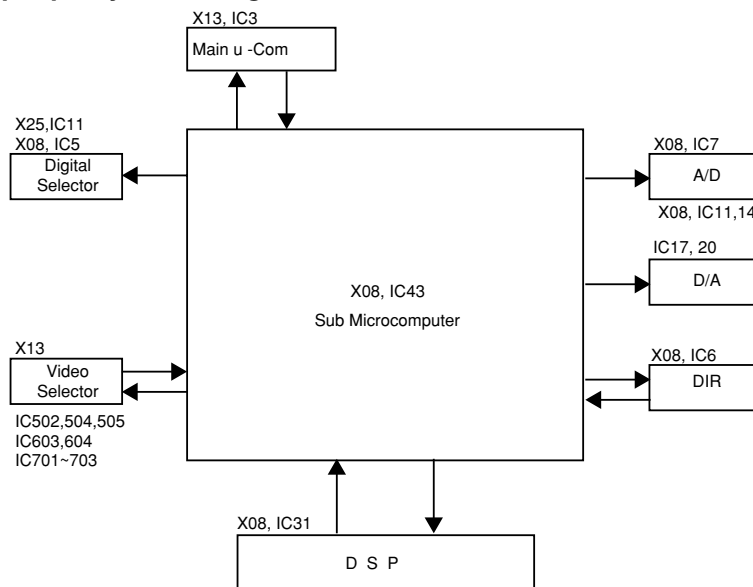

CIRCUIT DESCRIPTION

8-2 Port Description of Sub Microcomputer : uPD784224K507 (X08,IC43)

Port No.	Port Name	I/O	Function	ACTIVE	
				H	L
1	ERF	I	D.I.R. (X08, IC6) error flag.		
2	FS96 DET	I	96KHz fs detection. H : fs>88.1kHz detection		
3	AUTO	I	Non-PCM detection. H : Non-PCM detection		
4	AVSS	-	GND		
5	DIR PD	O	Power down for D.I.R. (X08, IC6). L : DIR power down and reset		
6	DIR CS	O	Chip select for D.I.R. (X08, IC6). L : Chip selection		
7	AVREF	-	Reference voltage.		
8	DIR DIN	I	Data input from D.I.R. (X08, IC6).		
9	DIR DOUT	O	Data output for D.I.R. (X08, IC6).		
10	DIR CLK	O	Clock output for D.I.R. (X08, IC6).		
11	D MUTE	O	Mute signal output for D.I.R. (X08, IC6).		Data mute
12	DAC PD	O	Power down for D/A converter (X08, IC11/14/17/20).		Power down
13	DAC 96K	O	Double speed sampling mode for D/A converter speed mode (X08, IC11/14/17/20). H : Double		
14	DAC MUTE	O	Mute signal output for D/A converter (X08, IC11/14/17/20).	Mute	
15	ADC RST	O	Reset signal output for A/D converter (X08, IC7).		Reset
16	MDT	I	Main microcomputer master data.		
17	SDT	O	Sub microcomputer data output.		
18	MCK	I	Main microcomputer control data clock		
19	MREQ	I	Main microcomputer master request.		
20	SREQ	O	Main microcomputer slave request.		
21	REC 6dB	O	Rec gain control when HDCD +6dB.	+6dB on	
22~24	DSEL A~C	O	Control port for digital input selector (A~C).		
25	DSP POWER	O	Power supply for DSP/DAC/ADC/DIR.		
26	DSP RESET	O	Reset signal output for DSP.		
27~32	DSP D0~D5	I/O	DSP control data.		
33	VSS	-	GND		
34,35	DSP D6,7	I/O	DSP control data.		
36	DSP REQ	O	DSP communication request.		Request
37	DSP ACK	I	Input port of command data reading from DSP.		Ack.
38	DSP BUSY	I	DSP status busy.	Busy	
39	DSP WRT	O	DSP Write	Data write	Data read
40	DTS DET	I	DSP DTS detection.	DTS	
41	PCM ZERO	I	PCM zero data detection.	PCM 0	
42	HDCD DET	I	DSP HDCD sync. Detection.	HDCD	
43	HDCD 6dB DET	I	DSP HDCD +6dB detection. (KPCM)	+6dB	
44	OVER LEVEL	I	DSP over level detection.	Over level	
45	PCM MUTE	O	DSP mute control (PCM).		Fixed
46	DRIVE	O	DSP D.R.I.V.E. /HDCD control (PCM).		D.R.I.V.E/ HDCD ON
47	SUB MUTE	O	Sub microcomputer analog mute.		Mute on
48~50	C ROOMB(C/B/A)	O	Zone B video selector control.		
51,52	YC SEL(B, A)	O	Zone A video selector control.		
53~59	C ROOMA(A~G)	O	Zone A video selector control.		
60	RESET	I	Reset signal input.		
61	YC MUTE	O	Zone A video selector (Y/C) mute control.		
62	FSC CTRL	O	Zone A video selector FSC control.		
63	VSEL	O	Zone A video selector control.		
64	CTRL A2	O	Zone A video selector control A2.		
65	CTRL B	O	Zone A video selector control B.		
66	CTRL A	O	Zone A video selector control A.		

CIRCUIT DESCRIPTION

Port No.	Port Name	I/O	Function	ACTIVE	
				H	L
67	VSS	-	GND		
68	VDD	-	Power supply (+3.3V).		
69	X2	-	Crystal resonator (6MHz) connection.		
70	X1	I	Crystal resonator (6MHz) connection.		
71	TEST	-	Pull down port.		
72	XT2	-	Unused.		
73	XT1	-	GND		
74	VDD	-	Power supply (+3.3V).		
75	AVDD	-	Power supply (+3.3V).		
76	NC	-	Unused.		
77	C DET	I	Zone A component signal detection.		Detection
78	Y DET	I	Zone A S-terminal signal detection.		Detection
79	CK DET	I	Zone A color killer detection.		
80	OPT DET	I	Optical digital input detection.		

9. Description of the Circuit Control

* The number in the () is pin number of sub microcomputer.

9-1 Digital Selector

• VR-5700/5900/5090/KRF-X9995D(for OPT and COAX)

INPUT	DSEL A(Pin22)	DSEL B(Pin23)	DSEL C(Pin24)
CD1	L	H	L
MD/TAPE1	H	H	L
CD-R	L	L	H
VIDEO2	H	L	H
VIDEO3	L	H	H
VIDEO4	H	H	H
DVD	H	L	L
OTHERS	L	L	L

• VR-5080/KRF-X7775D

INPUT	DSEL A (Pin22)	DSEL B (Pin23)	DSEL C (Pin24)
CD1(OPT)	L	H	L
VIDEO2(COAX)	L	H	L
VIDEO3(COAX)	H	H	L
DVD(OPT/COAX)	H	L	L
OTHERS	L	L	L

9-2 Video Selector

(BA7649AF,BA7611AF,BA7612F,BA7613F)

① VSEL

INPUT	VSEL(Pin63)
VIDEO1	L
VIDEO2	L
VIDEO3	L
VIDEO4	L
AV-AUX	L
DVD	H
V MUTE	L

② Y C Select

② -1 Y Detect(Pin78) = H

INPUT	Y C SEL A (Pin52)	Y C SEL B (Pin51)
VIDEO1	L	H
VIDEO2	L	H
VIDEO3	L	H
VIDEO4	L	H
AV-AUX	L	H
DVD	H	L
V MUTE	H	H

③ CTRL A, CTRL A2, CTRL B

③ -1 C Detect(Pin77) = L

VR-5900/5090/KRF-X9995D

② -2 Y Detect(Pin78) = L

INPUT	Y C SEL A (Pin52)	Y C SEL B (Pin51)
VIDEO1	L	L
VIDEO2	L	L
VIDEO3	L	L
VIDEO4	L	L
AV-AUX	L	L
DVD	L	L
V MUTE	H	H

INPUT	CTRL A (Pin66)	CTRL A2 (Pin64)	CTRL B (Pin65)
VIDEO1	L	L	H
VIDEO2	L	L	H
VIDEO3	L	L	L
VIDEO4	L	L	H
AV-AUX	L	L	H
DVD	H	H	L
V MUTE	H	H	H

CIRCUIT DESCRIPTION

③ -2 C Detect(Pin77) = H

- CK DET(Pin79) = L
- VR-5900/5090/KRF-X9995D

INPUT	CTRL A (Pin66)	CTRL A2 (Pin64)	CTRL B (Pin65)
VIDEO1	L	L	H
VIDEO2	L	L	H
VIDEO3	L	L	H
VIDEO4	L	L	H
AV-AUX	L	L	H
DVD	L	L	H
V MUTE	H	H	H

③ -3 CK DET(Pin79) = H

VR-5900/5090/KRF-X9995D

INPUT	CTRL A (Pin66)	CTRL A2 (Pin64)	CTRL B (Pin65)
VIDEO1	L	H	H
VIDEO2	L	H	H
VIDEO3	L	H	H
VIDEO4	L	H	H
AV-AUX	L	H	H
DVD	L	H	H
V MUTE	H	H	H

④ CPST A(Pin53~59)

④ -1 Y Detect(Pin78) = H

INPUT	CPST AA (Pin59)	CPST AB (Pin58)	CPST AC (Pin57)	CPST AD (Pin56)	CPST AE (Pin55)	CPST AF (Pin54)	CPST AG (Pin53)
VIDEO1	L	L	L	L	L	L	L
VIDEO2	H	H	H	H	L	L	L
VIDEO3	L	H	L	L	L	L	L
VIDEO4	L	H	H	L	L	L	L
AV-AUX	H	L	L	L	L	L	L
DVD	L	H	L	L	H	L	L
V MUTE	L	H	L	L	H	H	H

④ -2 Y Detect(Pin78) = L

INPUT	CPST AA (Pin59)	CPST AB (Pin58)	CPST AC (Pin57)	CPST AD (Pin56)	CPST AE (Pin55)	CPST AF (Pin54)	CPST AG (Pin53)
VIDEO1	L	L	L	L	L	L	H
VIDEO2	H	H	H	H	L	L	H
VIDEO3	L	H	L	L	L	L	H
VIDEO4	L	H	H	L	L	L	H
AV-AUX	H	L	L	L	L	L	H
DVD	L	H	L	L	H	H	L
V MUTE	L	H	L	L	H	H	H

⑤ CPST B(Pin48~50)

INPUT	CPST BA (Pin50)	CPST BB (Pin49)	CPST BC (Pin48)
VIDEO1	L	L	L
VIDEO2	L	H	L
VIDEO3	H	L	L
VIDEO4	H	H	L
DVD	L	H	H

10. Key Matrix

* The number in the () is pin number of FL driver (X25,IC1).

* KRF-X9995D/VR-5900 only

	Key	
Key 1(Pin26)	INPUT UP	* OPEN/CLOSE
Key 2(Pin27)	AUTO	BAND
Key 3(Pin28)	P. CALL UP	MEMORY
Key 4(Pin29)	P. CALL DOWN	MULTI CONT. UP
Key 5(Pin30)	SOUND/SET UP	MULTI CONT. DOWN
Key 6(Pin31)	LISTEN MODE	THX
Key 7(Pin32)	INPUT MODE	CD2/TAPE2 MONI.
Key 8(Pin33)	SPEAKER A	SPEAKER B

ADJUSTMENT

No.	ITEM	INPUT SETTINGS	OUTPUT SETTINGS	RECEIVER SETTINGS	ALIGNMENT POINTS	ALIGN FOR	FIG.
FM SECTION : SELECTOR : FM *Adjust NO.1 and NO.2 repeatedly.							
1	DISCRIMINATOR	(A) 98.0MHz 1kHz, ±40kHz dev. 70dBf (ANT. input)	Connect a DC voltmeter between CN2 ① and CN2 ② (X05)	MONO 98.0MHz	L4 (X05-)	0V	
2	DISTORTION (MONO)	(A) 98.0MHz 1kHz, ±40kHz dev. MONO 70dBf (ANT. input)	(B)	MONO 98.0MHz	L5 (X05-)	Minimum distortion	
3	DISTORTION (STEREO)	(C) 98.0MHz 1kHz, ±40kHz dev. Selector : L or R Pilot : ±6kHz dev. 70dBf (ANT. input)	(B)	AUTO 98.0MHz	IFT(RF FRONT END : A1) (X05-)	Minimum distortion (L or R)	
4	TUNING LEVEL	(A) 98.0MHz MONO 1kHz, ±40kHz dev. 30dBf (ANT. input)	—	MONO 98.0MHz	VR1 (X05-)	Adjust VR1 and stop at the point where ED1 (TUNED) goes on.	
AUDIO SECTION SPEAKER : A PREOUT : OFF PROLOGIC : ON							
<1>	IDLE CURRENT	—	Connect a DC voltmeter across each T.P. CN1(⑨, ⑩) FLch CN1(⑤, ⑥) Cch CN1(⑦, ⑧) FRch CN1(①, ②) SRch CN1(③, ④) SRch X07(A/5)	(FRONT 2ch MODE) Volume: Minimum	VR1(FL) VR2(FR) VR3(SL) VR4(SR) VR5(CENTER) X07(A/5)	Adjust every potentiometer 10 minutes later after turned the power on.	

SYSTEM CONNECTIONS

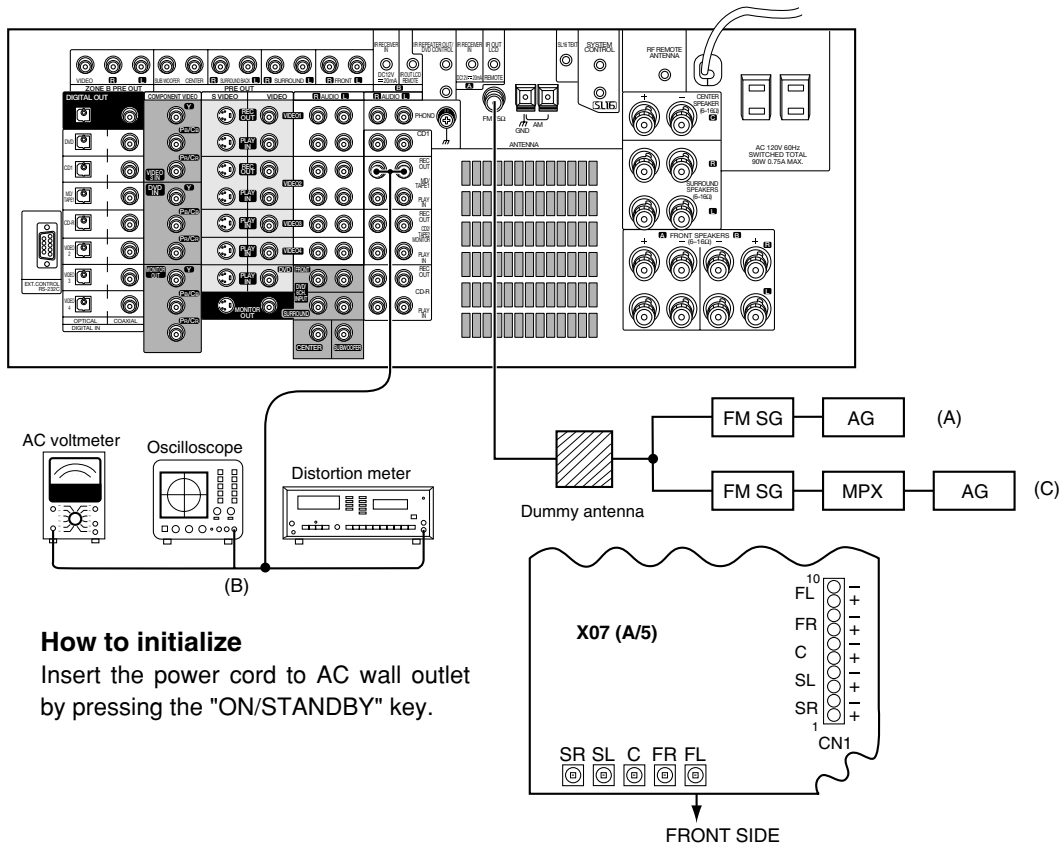

ADJUSTMENT

Adjustment of Sub Color and Contrast (X35, VR1, VR2)

Except KRF-X7775D/VR-5080

No.	ITEM	INPUT SETTINGS	OUTPUT SETTINGS	ALIGNMENT POINTS	ALIGNMENT FOR	FIG.
1	SUB COLOR	PAL 75% COLOR BAR (NO SET UP)	Connect a component video output(Y) to oscilloscope with 75Ω.	VR2	(Adjust an amplitude of video signal.) 0.825Vp - p	FIG.1
2	CONTRAST	PAL 75% COLOR BAR (NO SET UP)	Connect a component video output(Cb,Cr) to oscilloscope with 75Ω.	VR1	(Adjust an amplitude of video signal.) ±0.525Vp - p	FIG.2

INSTRUMENTS CONNECTION

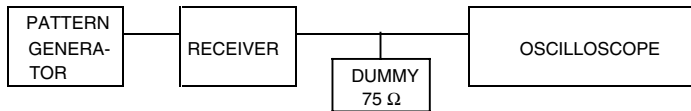

INPUT SIGNAL : 75% COLOR BAR SIGNAL

PARAMETER		WHITE	YELLOW	CYAN	GREEN	MAGENTA	RED	BLUE
LUMINANCE LEVEL	mV	525	465	368	308	217	157	60
	IRE							
CHROMA LEVEL	mV	0	470	664	620	620	664	470
	IRE							
CHROMA PHASE (deg)	+V		167	283	241	61	103	347
	-V		193	77	119	299	257	13

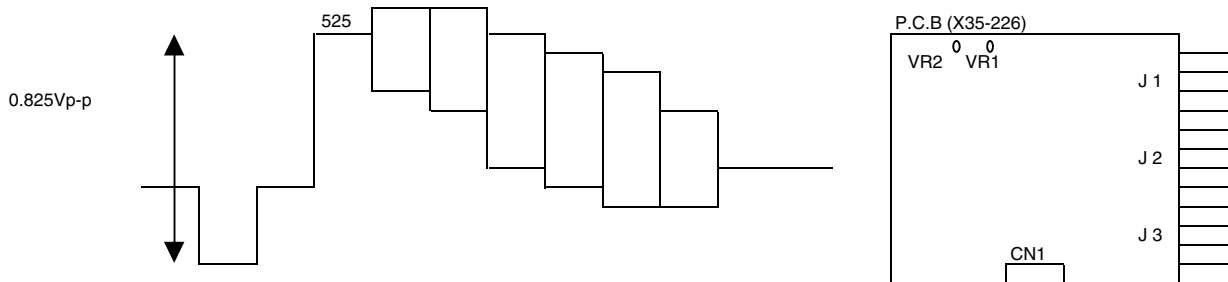

ADJUSTMENT OUTPUT SIGNAL :

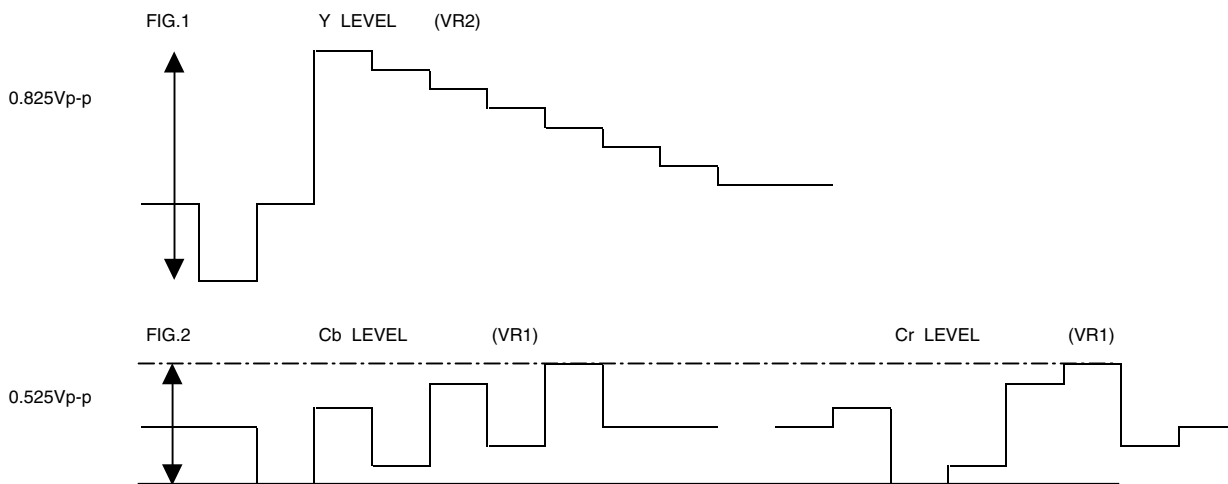

WIRING DIAGRAM

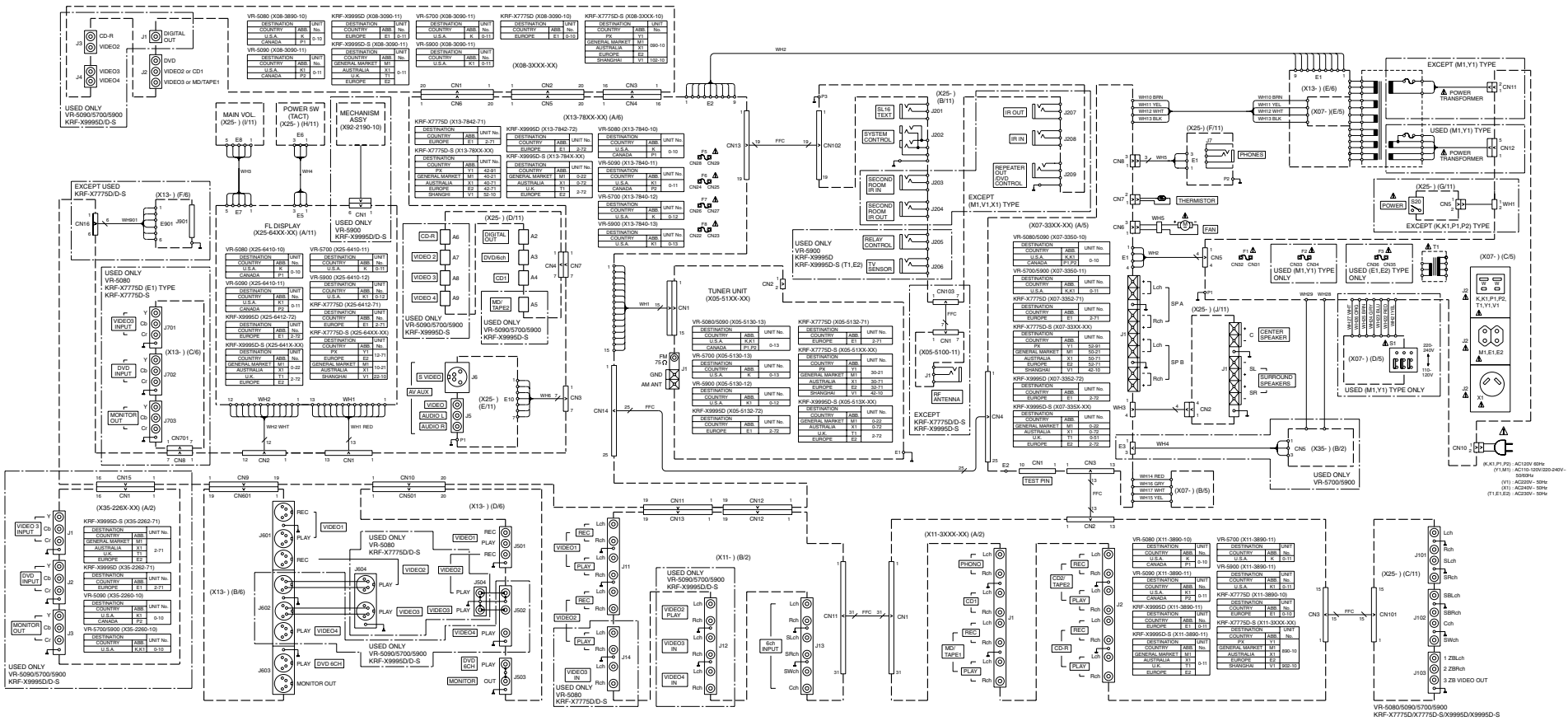

PC BOARD (Component side view)

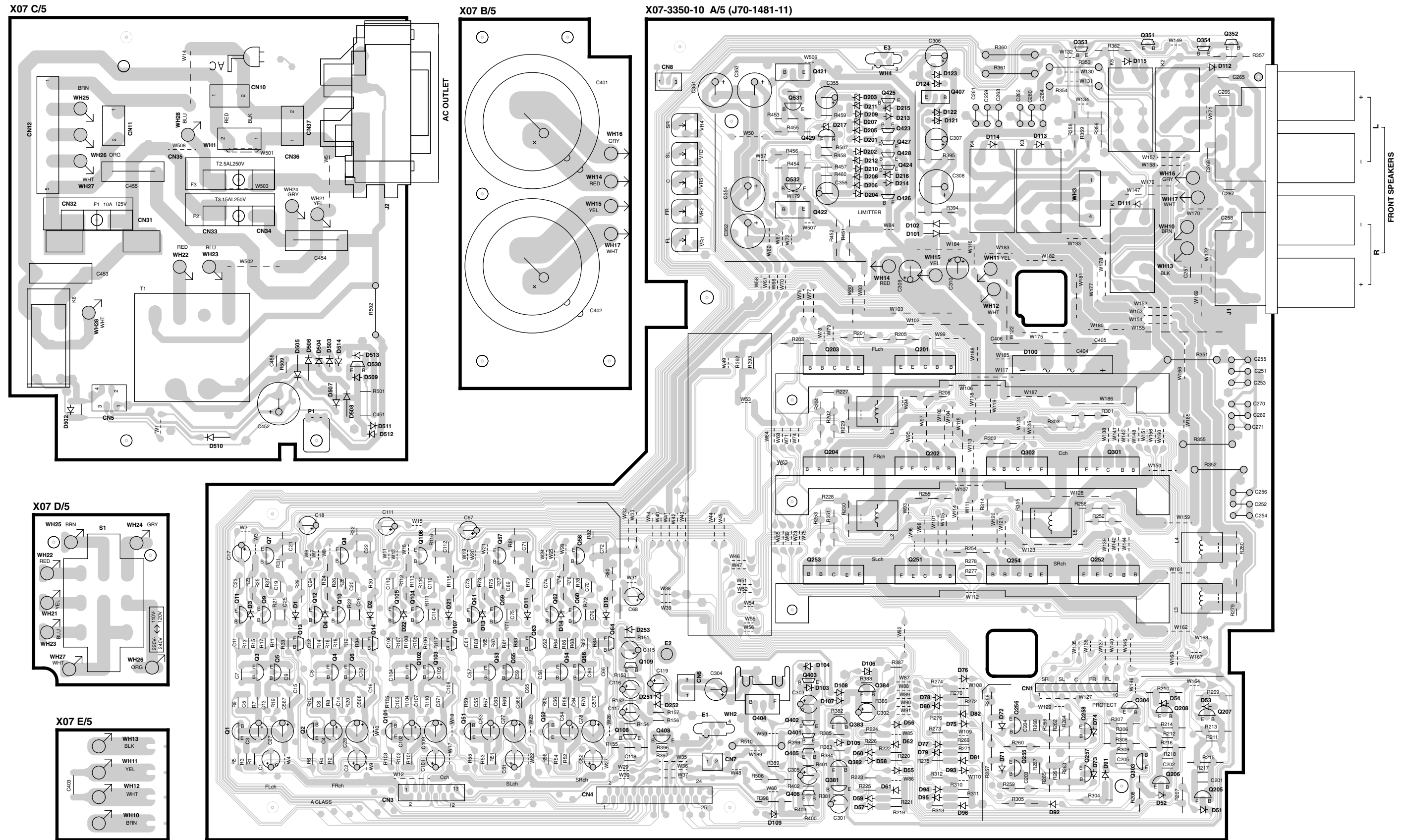

PC BOARD (Component side view)

X08-3090-11 (J70-1482-12)

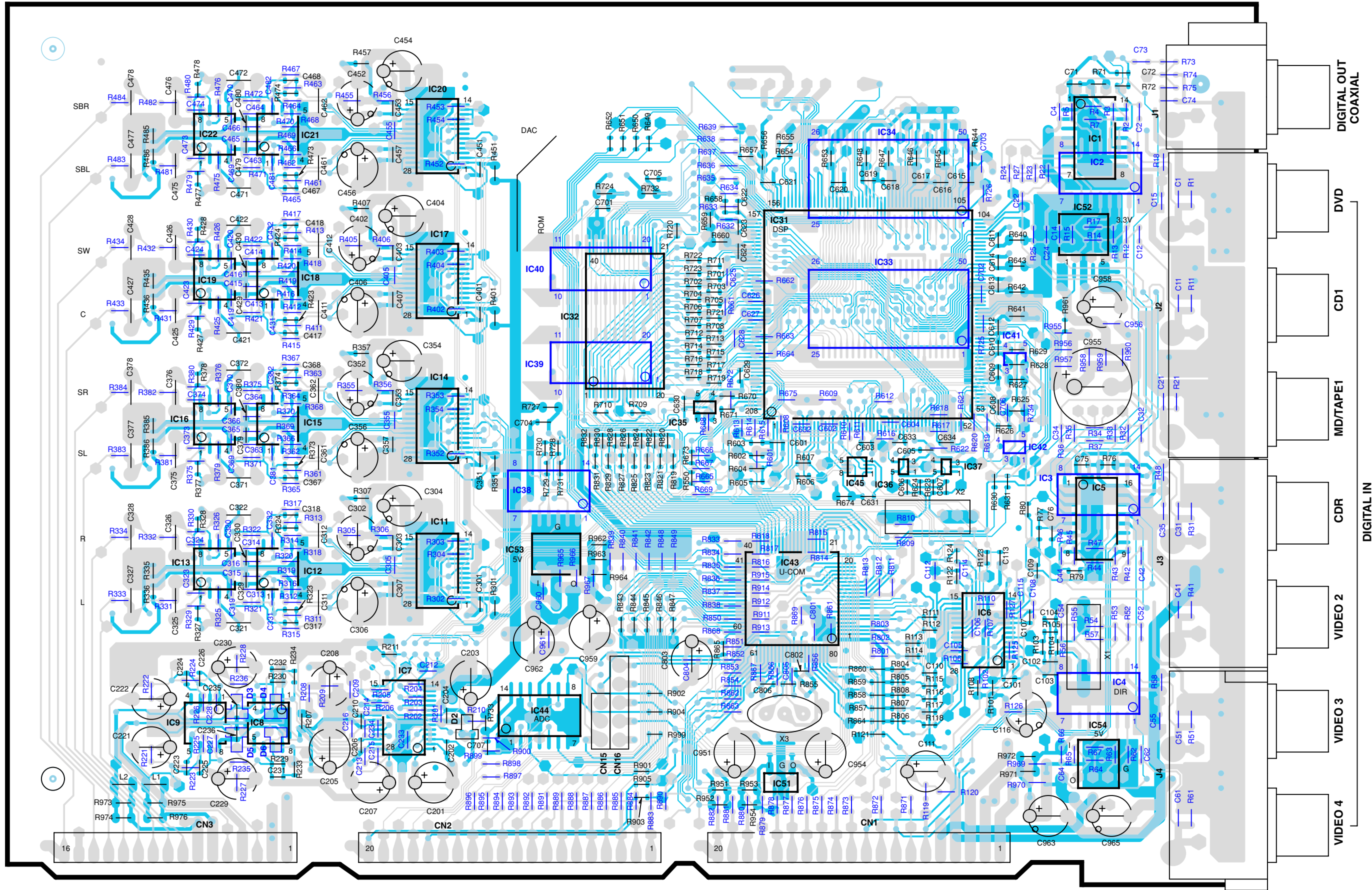

PC BOARD (Component side view)

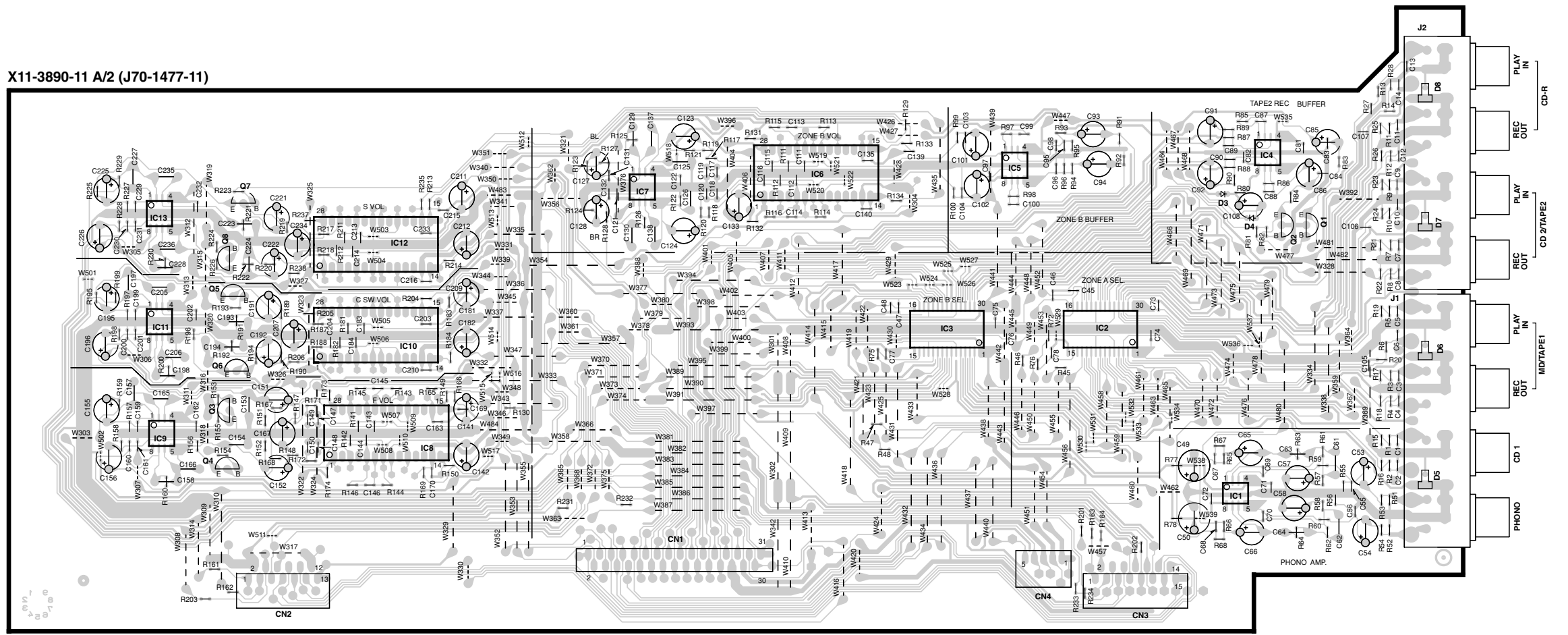
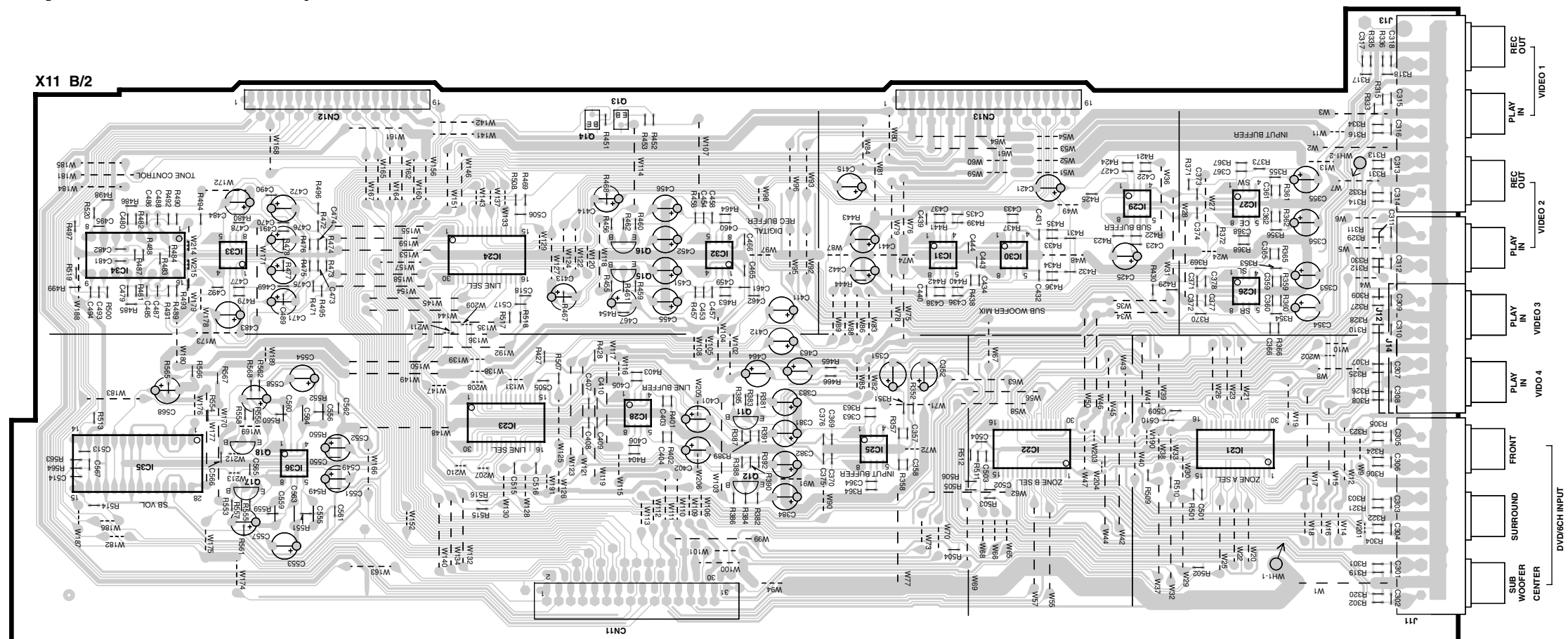

PC BOARD (Component side view)

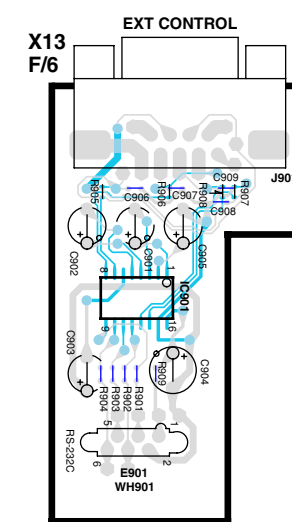
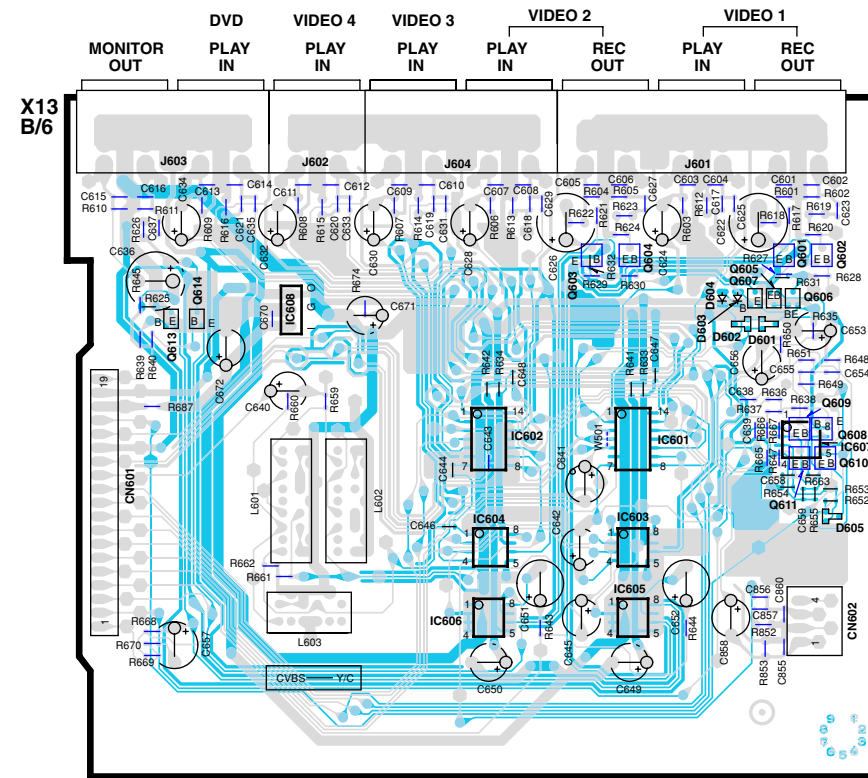
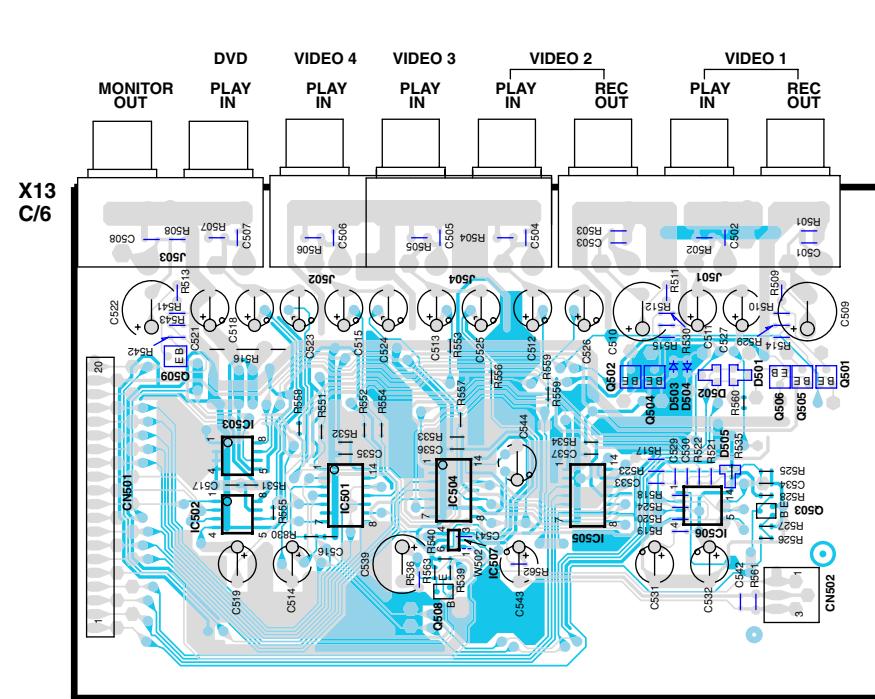

X13-7840-11 A/6 (J70-1472-11)

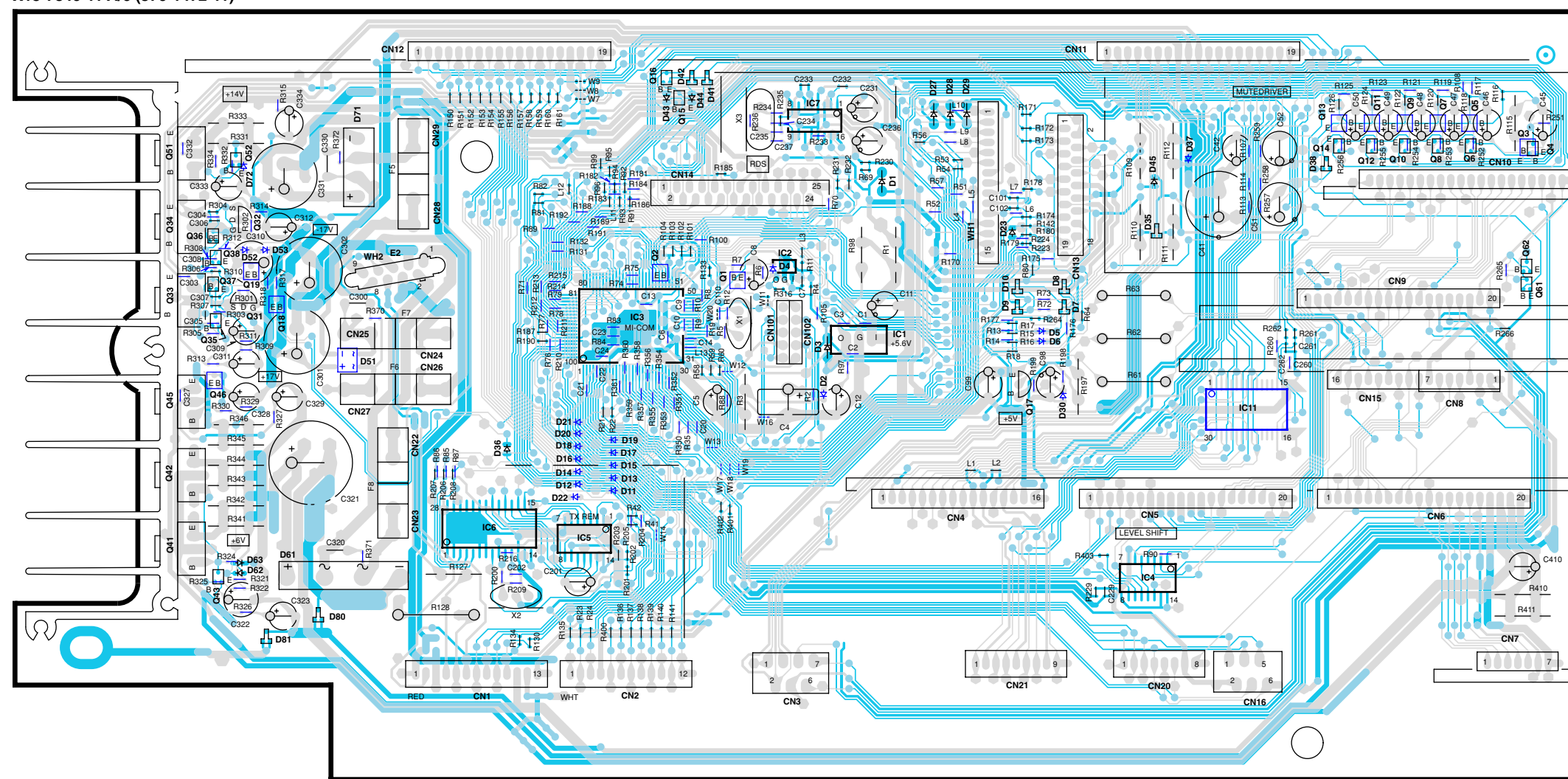

X13 E/6

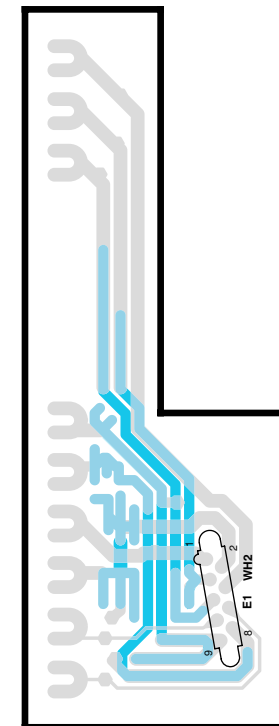

PC BOARD (Component side view)

X25 C/11

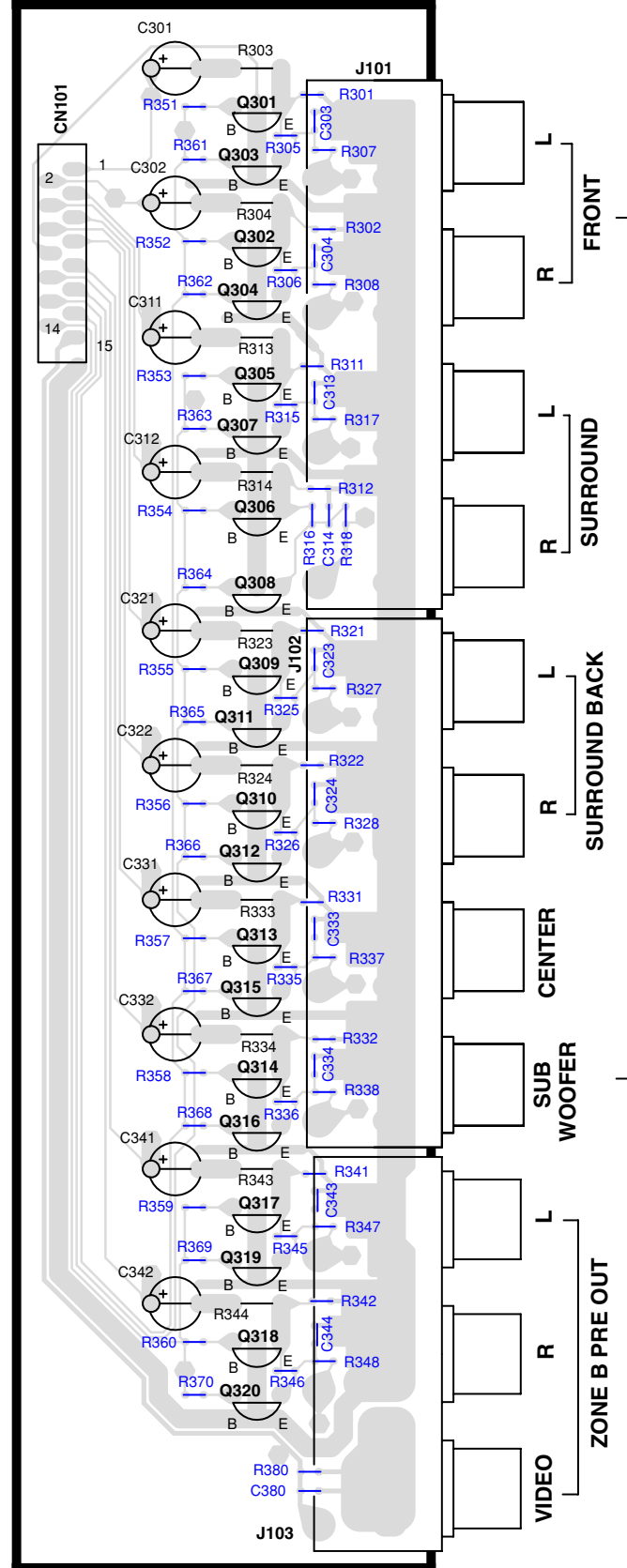

X25 J/11

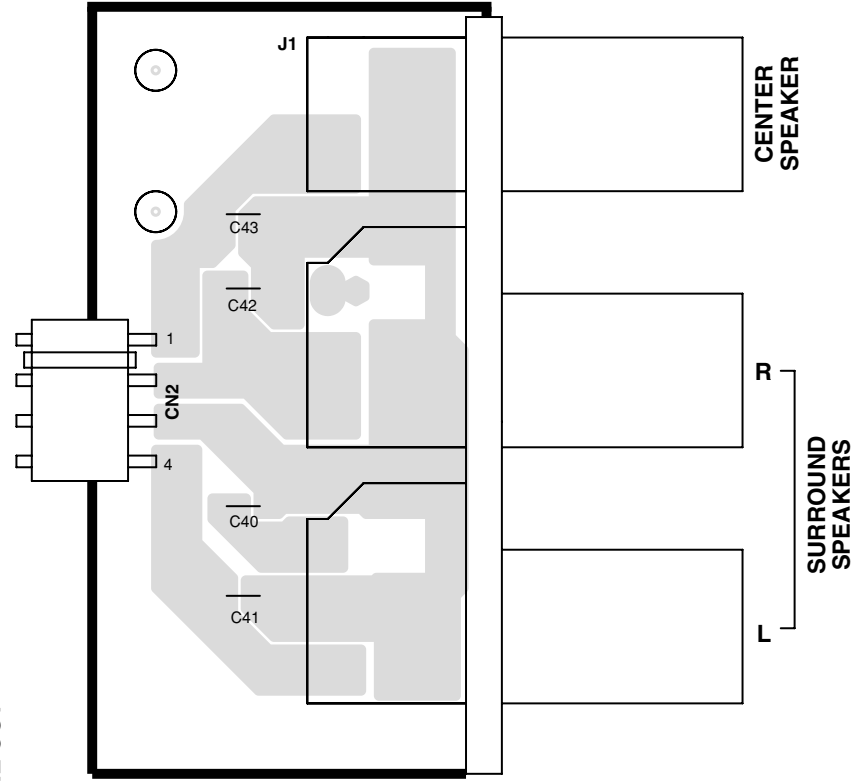

X25 G/11

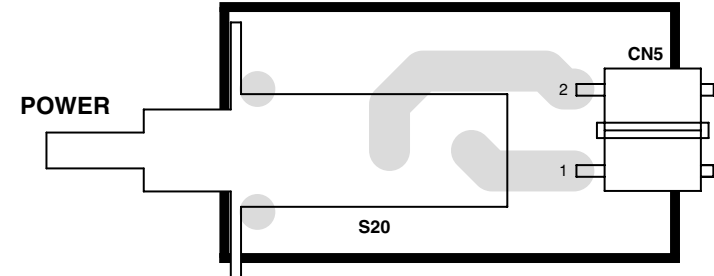

X25 F/11

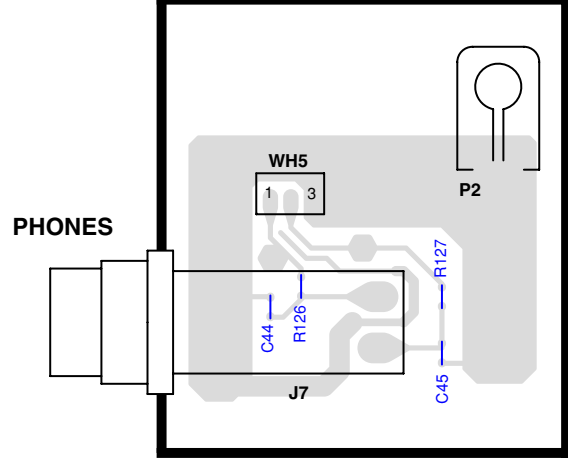

X35-2260-10 A/2 (J70-1475-11)

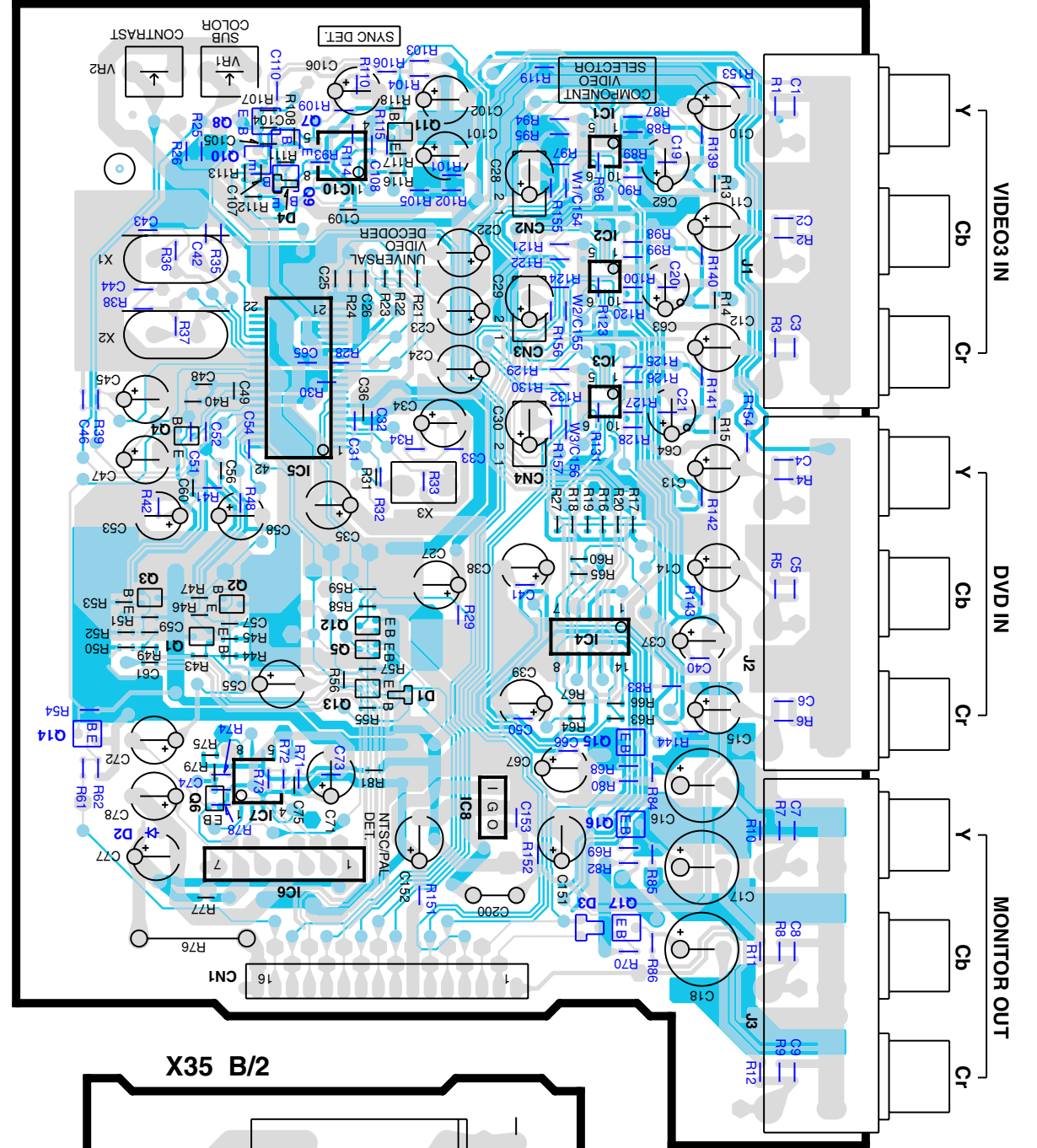

X35 B/2

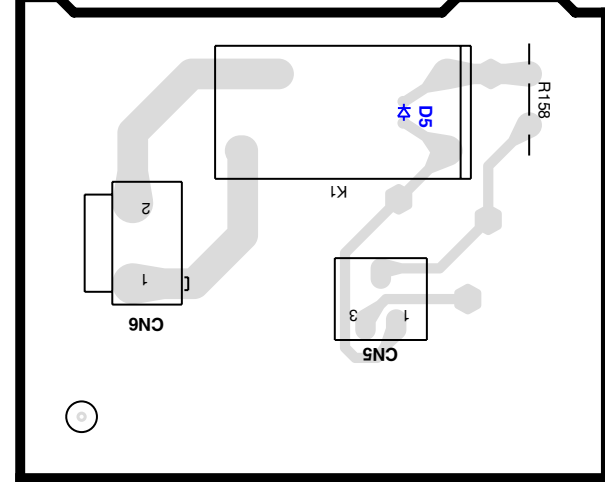

PC BOARD (Component side view)

X05-5130-13 (J70-1381-11)

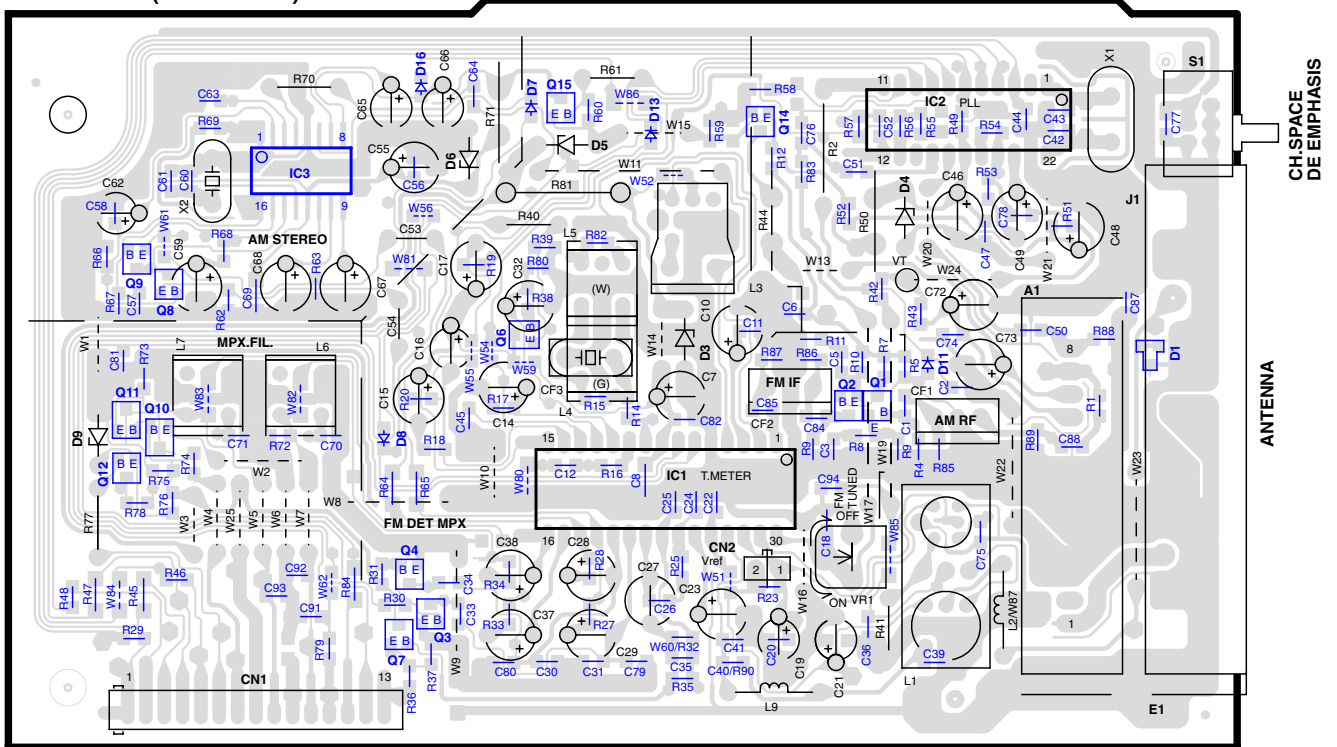

X05-5100-11 (J70-1411-32)

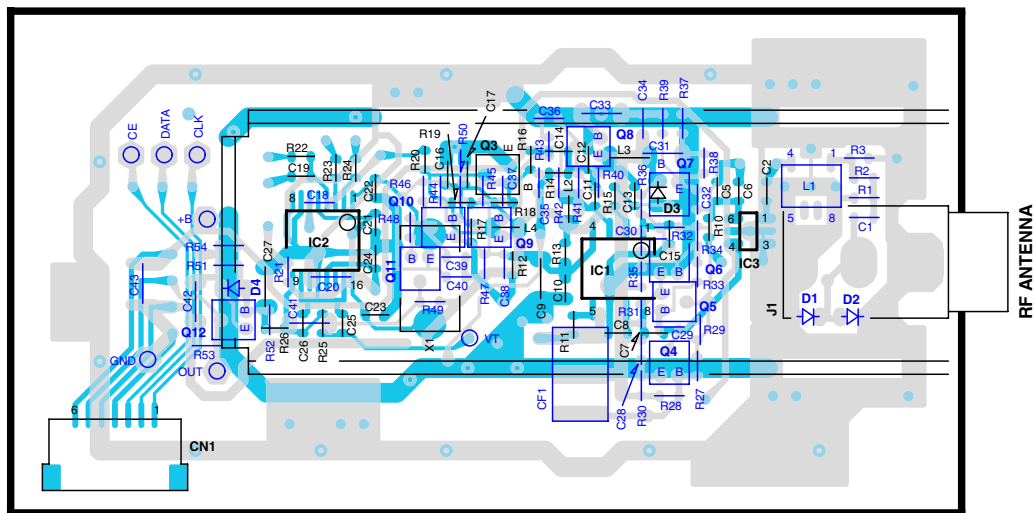

Refer to the schematic diagram for the value of resistors and capacitors.

TUNER UNIT (X05-51XX-XX)

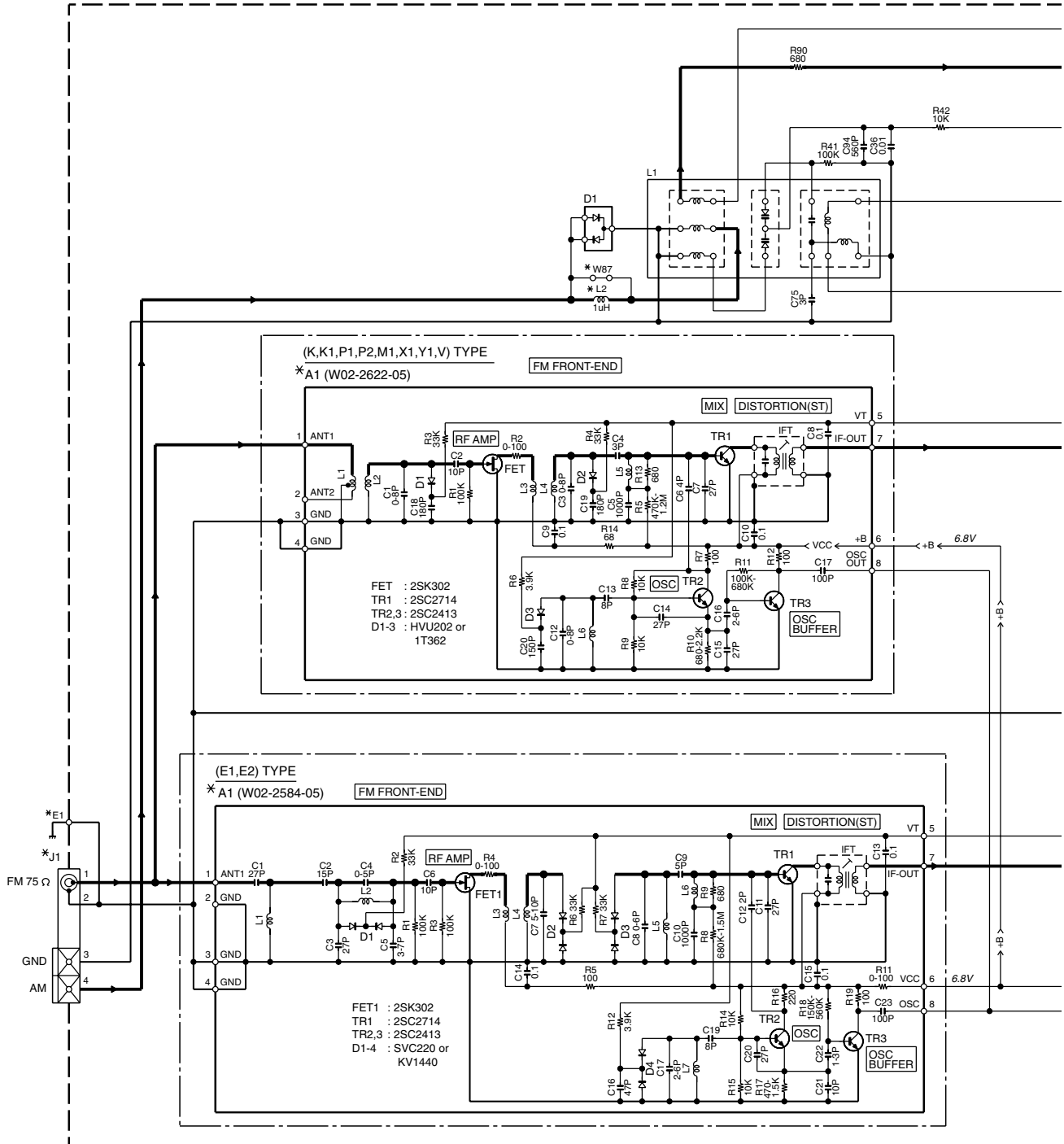

VR-5080/5090 (X05-5130-13)

DESTINATION	COUNTRY	ABB.	UNIT No.	(A)(B)(C)(F)	(B)	A1	C25	C30, 31	C70, 71, 77	C74, 92, 93	C79, 80	CF1,2	E1	J1	L2, 6,7	R8, 11	R23	R25	R27, 28	R29	R72, 73	S1	W56	W82, 83,87	
U.S.A.	K,K1		0-13	NO	NO	W02-2622	180P	0.033	NO	YES	1000P	L72-0596(MS2)	F10-1108	E70-0141	NO	33	4.7K	18K	6.8K	NO	33K	NO	NO	NO	YES
CANADA	P1,P2																								

KRF-X7775D (X05-5132-71)

DESTINATION	COUNTRY	ABB.	UNIT No.	(A)(C)(F)	(B)	A1	C25	C30, 31	C70, 71, 78,82	C74, 92, 93	C77	C79, 80	CF1,2	E1	J1	L2, 6,7	R8	R11	R23	R25	R27, 28	R29	R72, 73	S1	W56	W82, 83,87	
EUROPE	E1		2-71	YES	NO	W02-2584	180P	0.022	YES	NO	NO	4700P	L72-0536(MS3)	F10-1109	E70-0080	YES	10	22	15K	27K	4.3K	NO	NO	3.9K	NO	NO	NO

KRF-X7775D-S (X05-51XX-XX)

DESTINATION	COUNTRY	ABB.	UNIT No.	(A)(C)(F)	(B)	A1	C25	C30, 31	C70, 71, 92,93	C77	C79, 80	CF1,2	E1	J1	L2, 6,7	R8	R11	R23	R25	R27, 28	R29	R72, 73	S1	W56	W82, 83,87	
SHANGHAI	V		42-10																							
GENERAL MARKET	M1		30-21	NO	YES	W02-2622	330P	0.022	NO	YES	1500P	L72-0531(MA5)	F10-1108	E70-0080	NO	33	33	4.7K	18K	6.8K	NO	YES	33K	YES	YES	YES
AUSTRALIA	X1		30-71																							
EUROPE	E2		32-71	YES	NO	W02-2584	180P		YES	NO	NO	4700P	L72-0536(MS3)	F10-1109	YES	10	22	15K	27K	4.3K	NO	NO	3.9K	NO	NO	NO

CAUTION: For continued safety, replace safety critical components only with manufacturer's recommended parts (refer to parts list). Δ indicates safety critical components. For continued protection against risk of fire, replace only with same type and rating fuse(s). To reduce the risk of electric shock, leakage-current or resistance measurements shall be carried out (exposed parts are acceptably insulated from the supply circuit) before the appliance is returned to the customer.

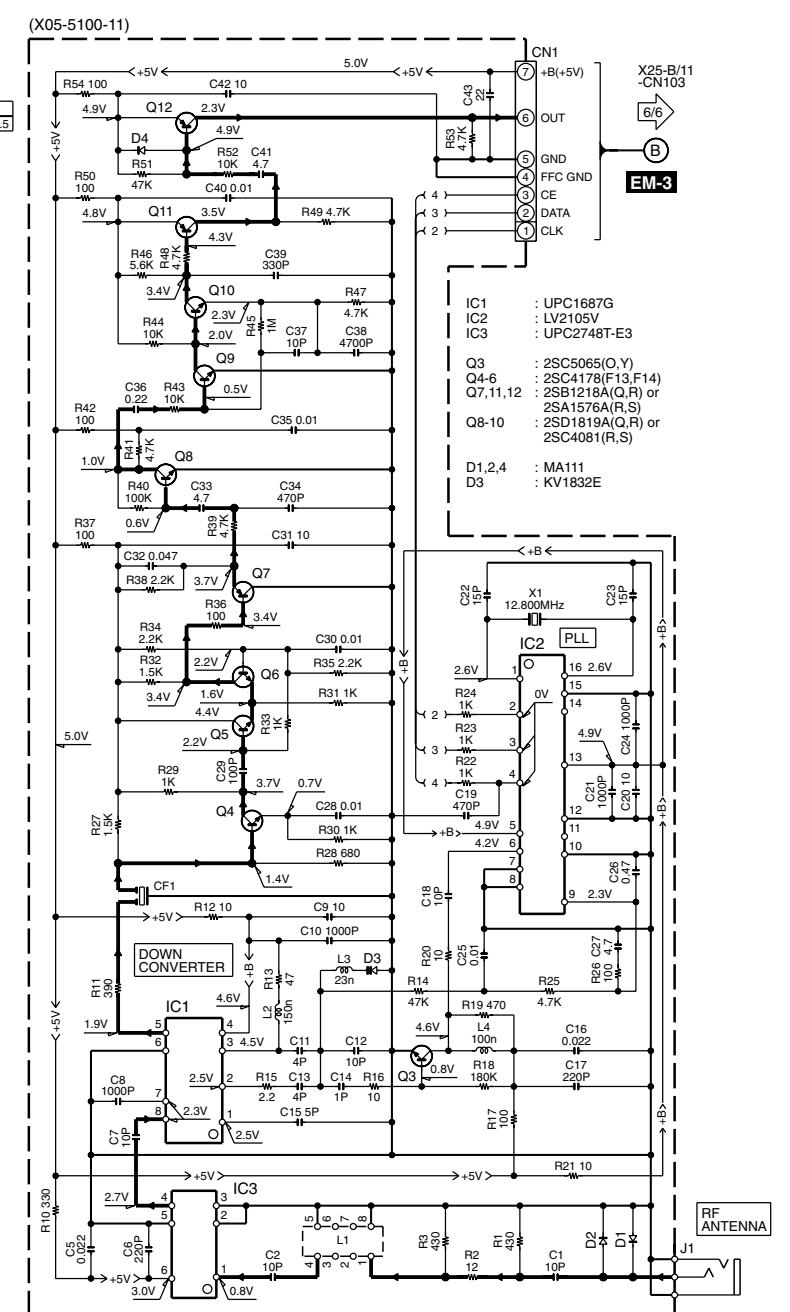
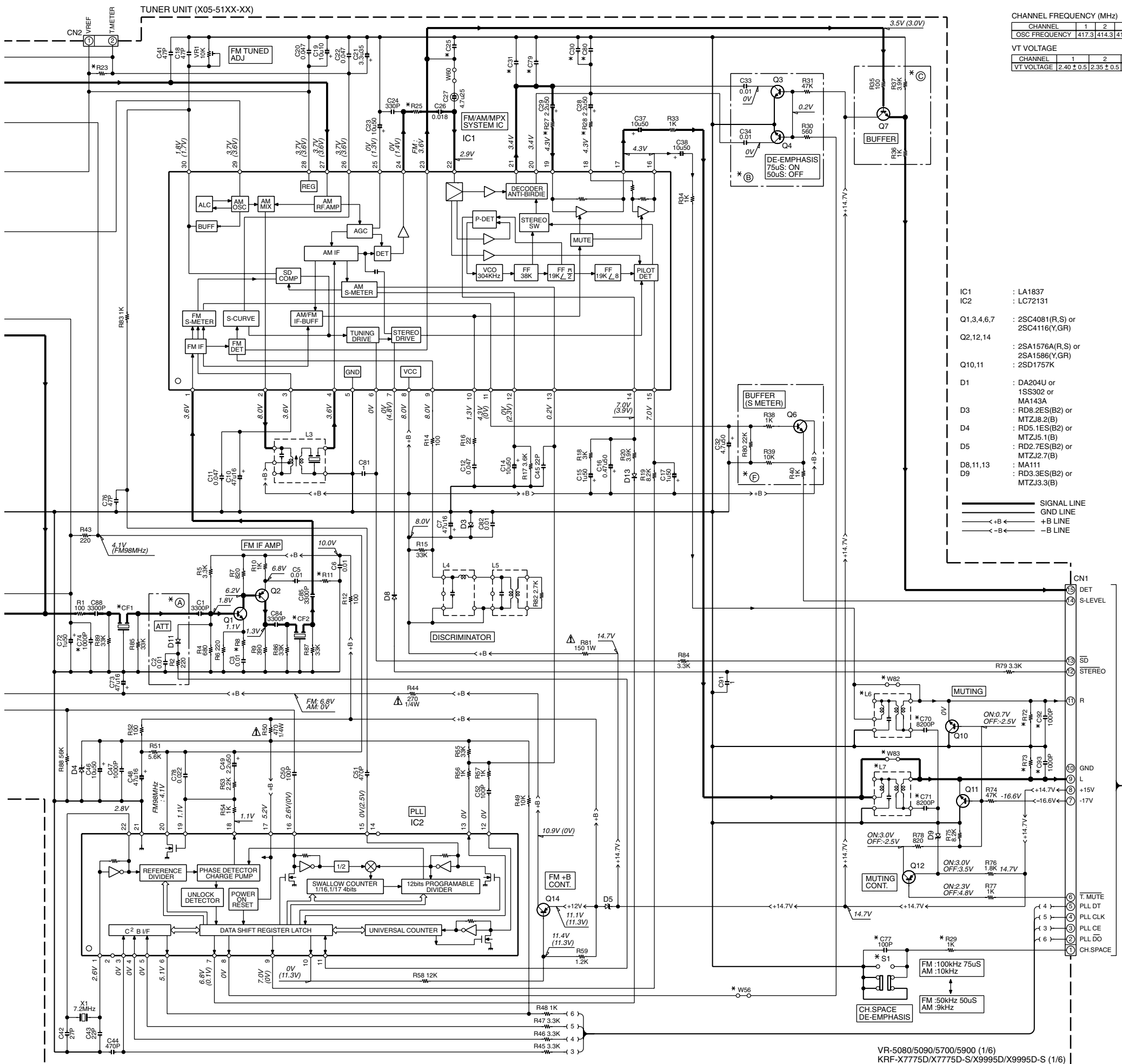

The DC voltage is an actual reading measured with a high impedance type voltmeter as the AM/FM signal generator is specified to the conditions as shown in the list below. The measurement value may vary depending on the measuring instruments used or on the product. The value shown in () is actual reading measured in the AM mode.

MODE	CARRIER	MODULATION		ANT INPUT
		FREQUENCY	DEVIATION	
FM	98MHz	1kHz	STEREO 67.5kHz 7.5kHz(Pilot)	60dB
AM	1000(999)kHz	400Hz	MONO 30% MOD	60dB

VR-5080/5090/5700/5900 (1/6)
 KRF-X7775D/X7775D-S/X9995D/X9995D-S (1/6)

Y05-4210-10

KENWOOD

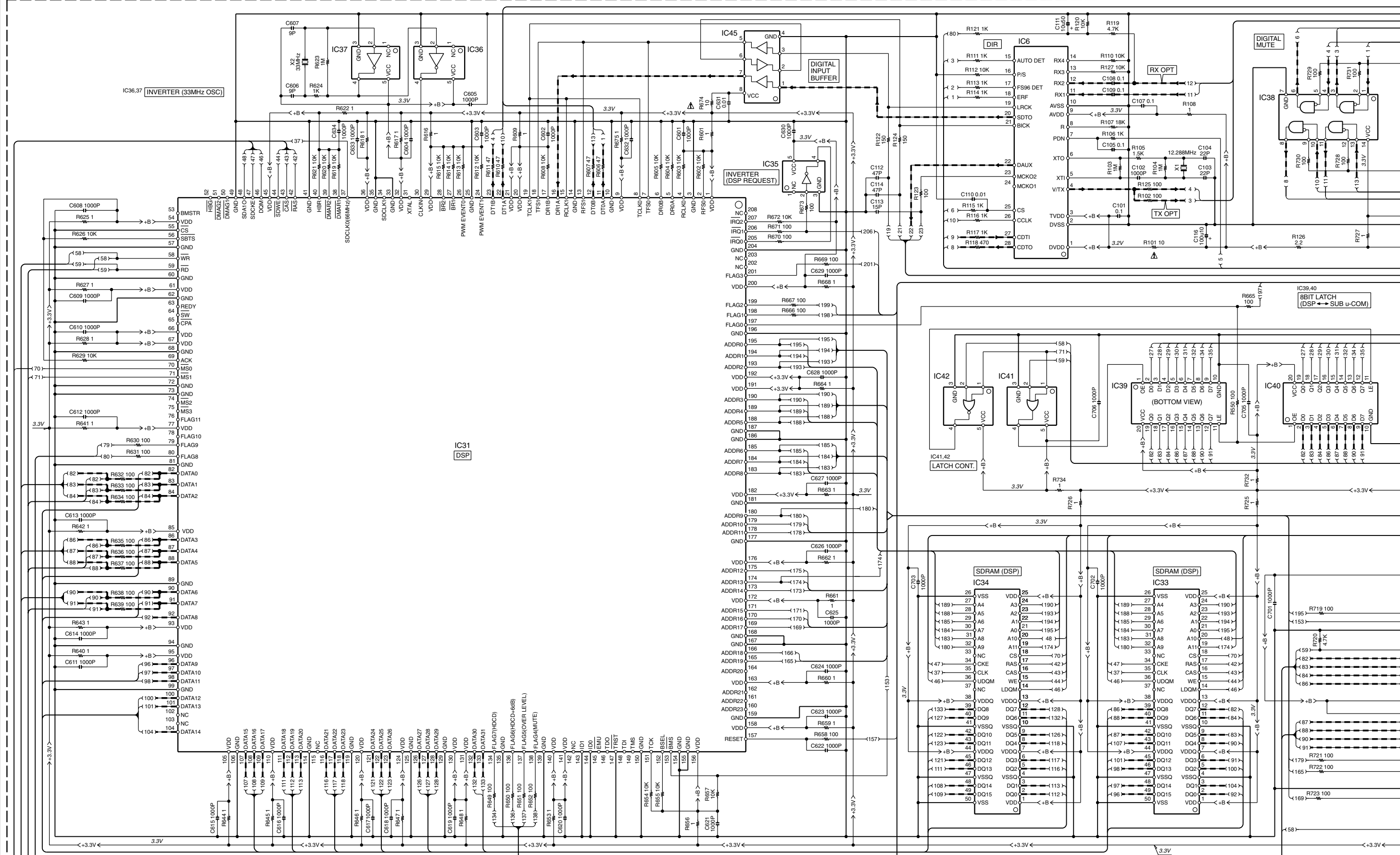

The DC voltage is an actual reading measured with a high impedance type voltmeter with a cassette loaded at playback mode. The measurement value may vary depending on the measuring instruments used or on the product. Bias circuit DC voltage is measured while in the record mode.

DOLBY and the double-D symbol are trademarks of Dolby Laboratories Licensing Corporation. Noise reduction circuit made under license from Dolby Laboratories Licensing Corporation.

(X08-3XXX-XX)

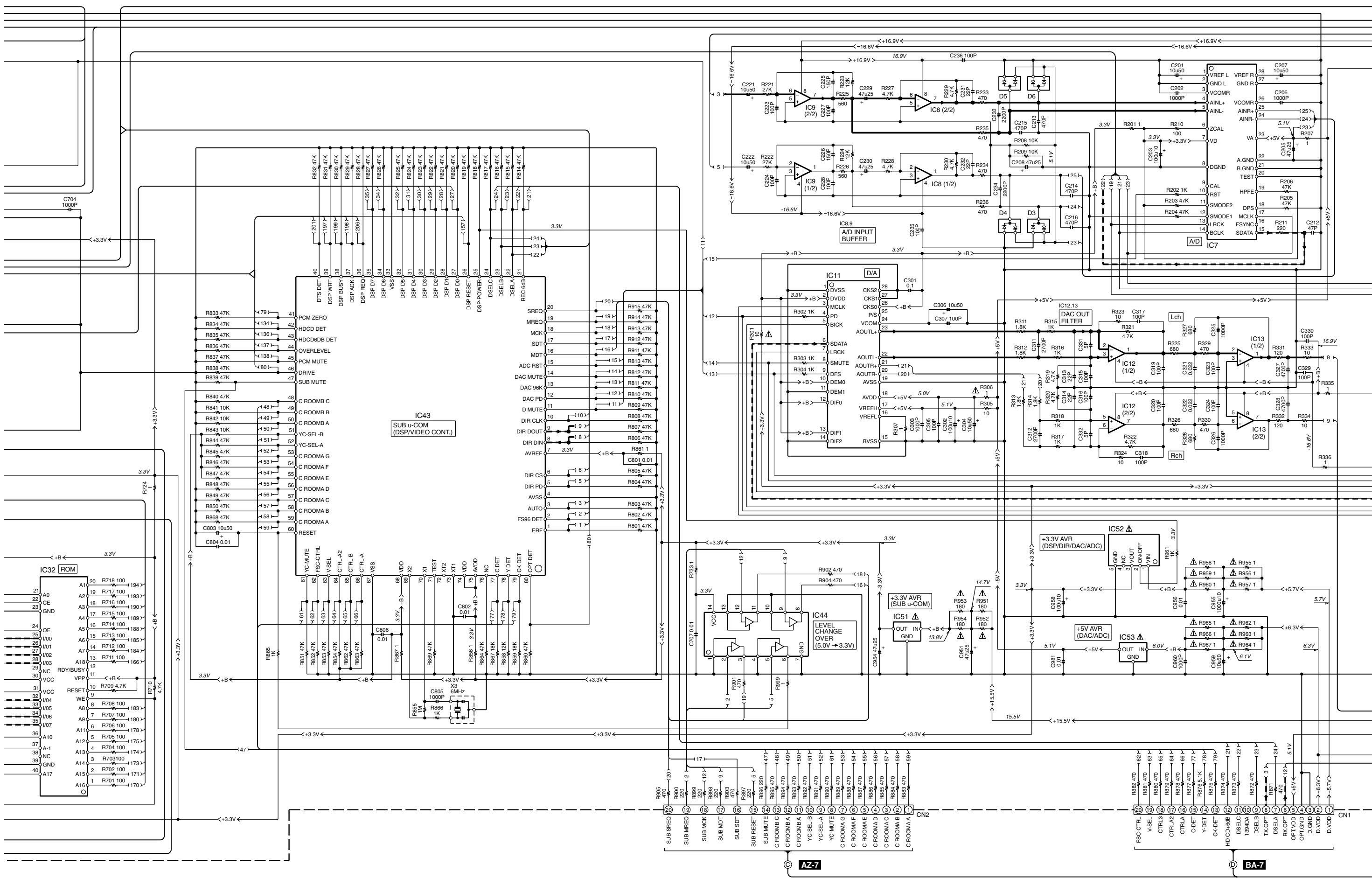

AZ-7

BA-7

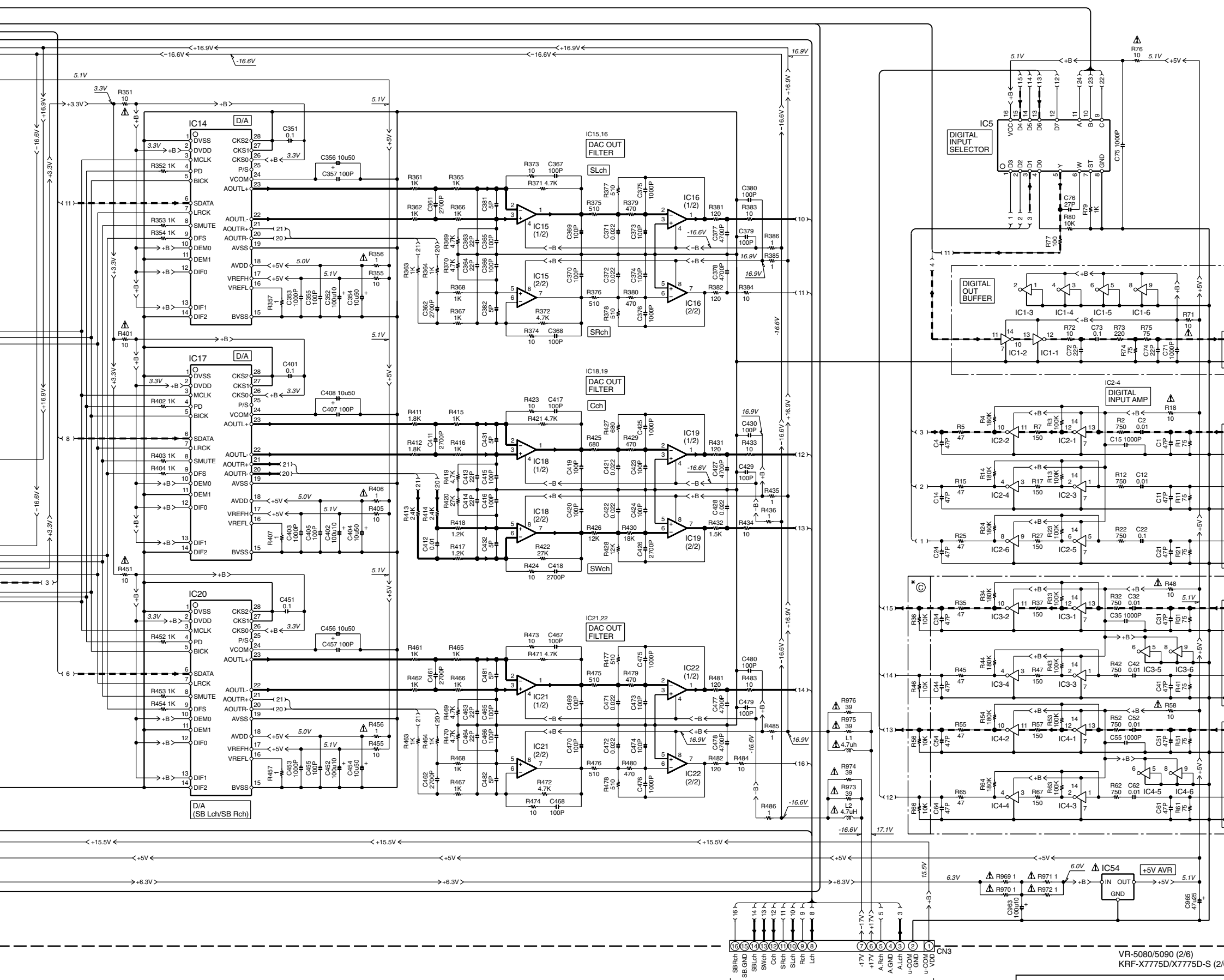

VR-5080 (X08-3890-10)

DESTINATION	UNIT No.	A	B	C	J2
COUNTRY	ABB.				
U.S.A.	K	0-10	NO	YES	E63-1129-05
CANADA	P1				

VR-5090 (X08-3090-11)

DESTINATION	UNIT No.	A	B	C	J2
COUNTRY	ABB.				
U.S.A.	K1	0-11	YES	NO	E63-1130-05
CANADA	P2				

KRF-X7775D (X08-3090-XX)

DESTINATION	UNIT No.	A	B	C	J2
COUNTRY	ABB.				
EUROPE	E1	0-10	NO	YES	E63-1129-05

KRF-X7775D-S (X08-3XXX-10)

DESTINATION	UNIT No.	A	B	C	J2
COUNTRY	ABB.				
FX	Y1				
GENERAL MARKET	M1	090-10			
AUSTRALIA	X1		NO	YES	E63-1129-05
EUROPE	E2				
SHANGHAI	V	102-10			

- IC1-4 : TC74HC04AF
 - IC5 : TC74HC151AF
 - IC6 : AK4112BVF
 - IC7 : AK5383VF
 - IC8,9,12,13,15,16,18,19,21,22 : NJM4565MD
 - IC11,14,17,20 : AK4393VF or AK4393-VF
 - IC31 : ADSST-A-3525
 - IC32 : 49B7008A1ALA
 - IC33,34 : HY57V16160DTC
 - IC35 : TC7S04F
 - IC36,37 : TC7SHU04FU
 - IC38 : TC74HC08AF
 - IC39,40 : TC74LVX573F
 - IC41 : TC7SH32F
 - IC42 : TC7SH02F
 - IC43 : uPD784224K507
 - IC44 : TC74VHC125F
 - IC45 : TC7WH34FK
 - IC51 : uPC29L33T
 - IC52 : PQ3D213
 - IC53,54 : uPC29M05T
- D3-6 : DA204U or 1SS302

CAUTION: For continued safety, replace safety critical components only with manufacturer's recommended parts (refer to parts list). Δ indicates safety critical components. For continued protection against risk of fire, replace only with same type and rating fuse(s). To reduce the risk of electric shock, leakage-current or resistance measurements shall be carried out (exposed parts are acceptably insulated from the supply circuit) before the appliance is returned to the customer.

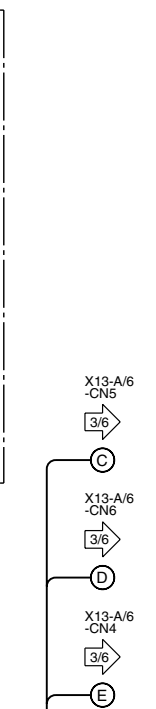
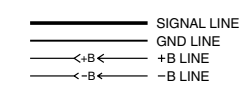

VR-5080/5090 (2/6)
KRF-X7775D/X7775D-S (2/6)

KRF-X7775D/X7775D-S/VR-5080/5090

X05-513/514
CN1
1/6
A
X08-CN3
2/6
E

IC1 : TA78057S
IC2 : S-80740AL-A4 or S-80840ALUP
IC3 : UPD784217A516
IC4 : TC74HCT7007AF
IC5 : TC74HC164AF
IC6 : UPD17215GT-737
IC7 : LC72723M

Q1,35,37,43,46,52 : 2SC4081(R,S) or 2SC4116(Y,GR)
Q2,16,61 : DTC124EUA or UN5212
Q3,5,7,9,11,13 : DTA113ZUA or UN5119
Q4,6,8,10,12,14 : DTC143TUA or UN5216
Q15,18,62 : DTA143TUA or UN5116
Q17 : 2SC3940A(R,S)
Q19 : 2SC4213(B)
Q31,32 : 2SK246(Y,GR)
Q33,34,41,42,45 : 2SB1375
Q36,38 : 2SA1576A(R,S) or 2SA1586(Y,GR)
Q51 : 2SD2012

D1,3,27-29 : U1BC44
D2,4-6,11,23,36,37,43-45,63 : MA111
D7,9,35,38 : DAN202U or 1SS301
D8,10,41,42 : DAP202U or 1SS300
D30 : UDZ55.6B or UDZ5.6B
D51 : S1ZB20(4072)
D52 : UDZ58.2B or UDZ28.2B
D53 : UDZ57.5B or UDZ7.5B
D61 : D4SBL20UF03
D62 : UDZ56.2B or UDZ6.2B
D71 : KBP02ML-6127
D72 : UDZ16B
D80,81 : DA204U or 1SS302

X08-CN2
2/6
C
X08-CN1
2/6
D

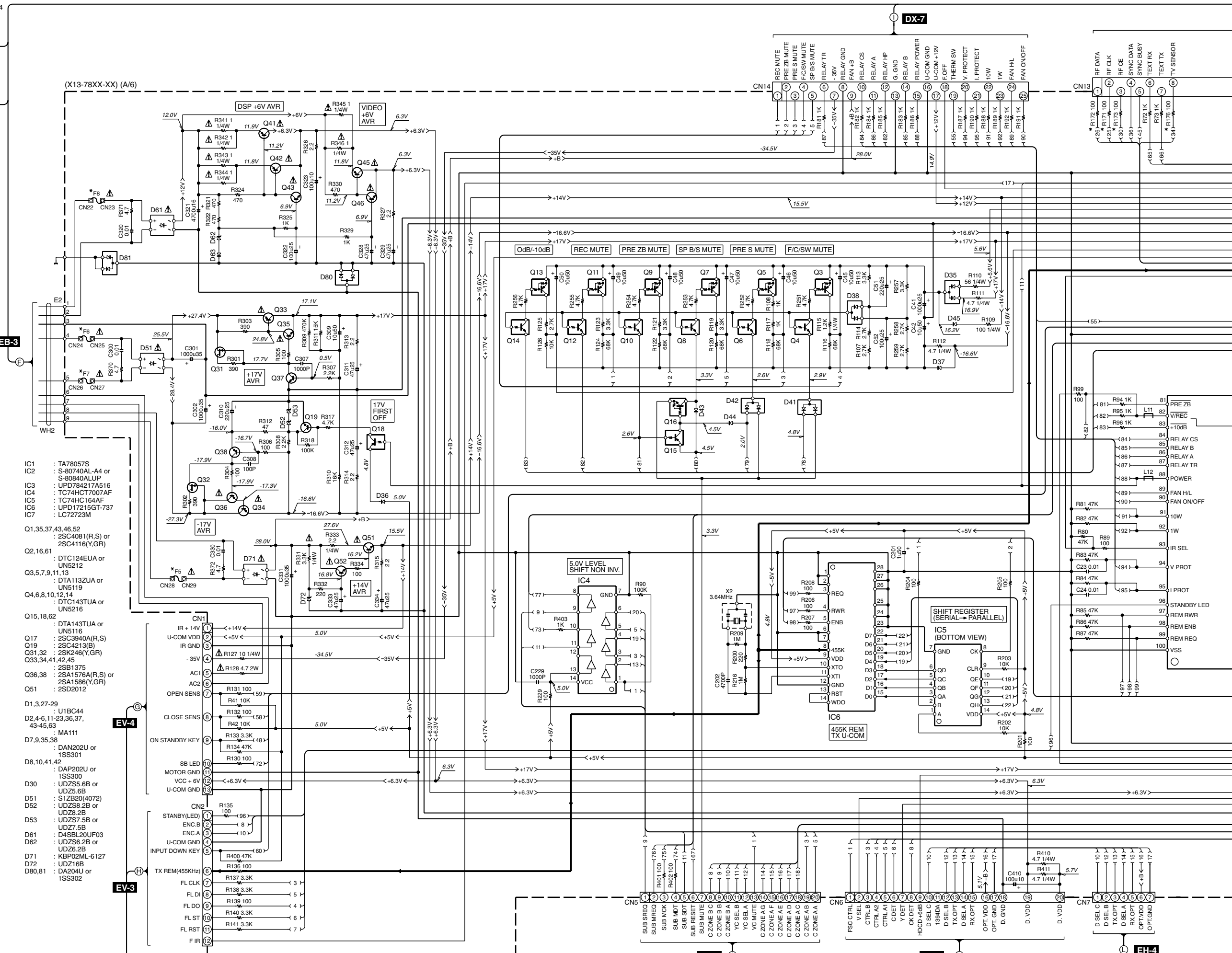

EB-3
F

EV-4
G

EV-3
H

AE-7
C

AH-7
D

EH-4
L

2

3

4

5

6

7

AT

AU

AV

AW

AX

AY

AZ

BA

BB

BC

DX-7

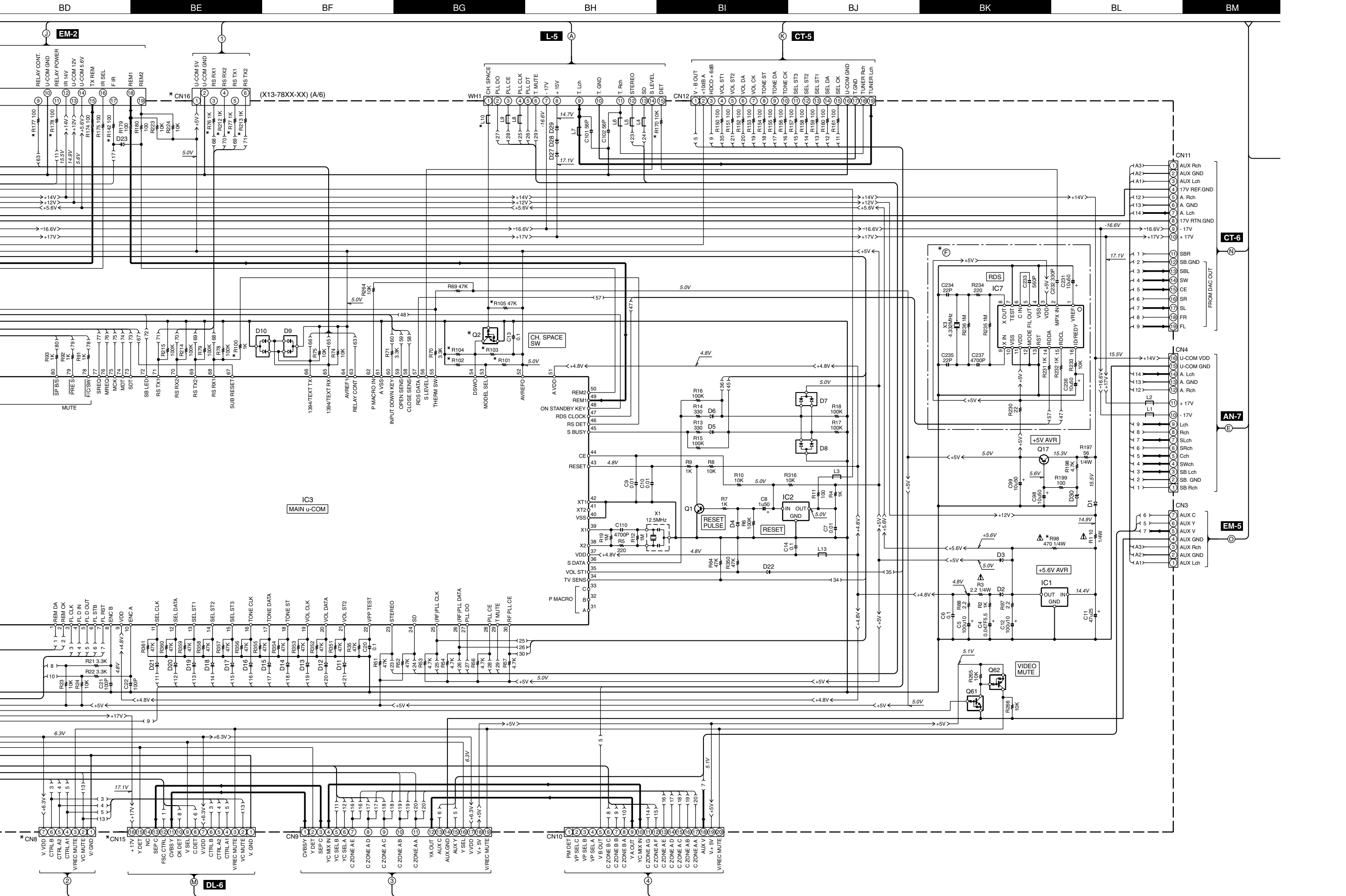

EM-2

L-5

CT-5

(X13-78XX-XX) (A/6)

IC3
MAIN u-COM

DL-6

CT-6

AN-7

EM-5

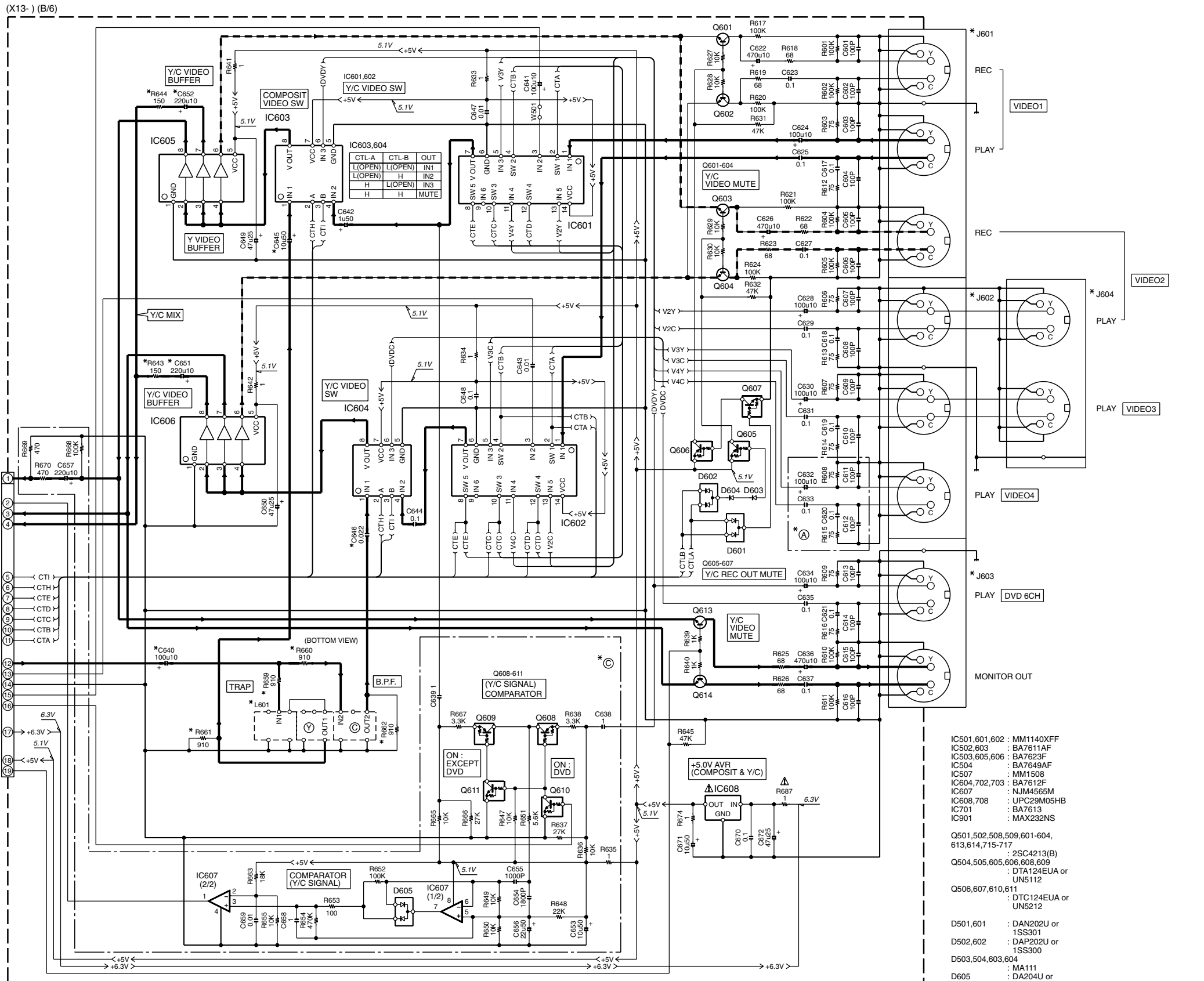

VR-5080/5090 (3/6)
KRF-X7775D/X7775D-S (3/6)

- IC501,601,602 : MM1140XFF
 - IC502,603 : BA7611AF
 - IC503,605,606 : BA7623F
 - IC504 : BA7649AF
 - IC507 : MM1508
 - IC604,702,703 : BA7612F
 - IC607 : NJM4565M
 - IC608,708 : UPC29M05HB
 - IC701 : BA7613
 - IC901 : MAX232NS
-
- Q501,502,508,509,601-604,
613,614,715-717 : 2SC4213(B)
 - Q504,505,605,606,608,609 : DTA124EUA or UN5112
 - Q506,607,610,611 : DTC124EUA or UN5212
 - D501,601 : DAN202U or 1SS301
 - D502,602 : DAP202U or 1SS300
 - D503,504,603,604 : MA111
 - D605 : DA204U or 1SS302

- X13-E/6 -E1
- X07-A/5 -CN4
- X25-B/11 -CN102
- X11-B/2 -CN12
- X11-B/2 -CN13
- X25-E/11 -E10
- X25-A/11 -WH1
- X25-A/11 -WH2
- X25-D/11 -CN4
- X35-CN1

CAUTION: For continued safety, replace safety critical components only with manufacturer's recommended parts (refer to parts list). Δ indicates safety critical components. For continued protection against risk of fire, replace only with same type and rating fuse(s). To reduce the risk of electric shock, leakage-current or resistance measurements shall be carried out (exposed parts are acceptably insulated from the supply circuit) before the appliance is returned to the customer.

DOLBY and the double-D symbol are trademarks of Dolby Laboratories Licensing Corporation. Noise reduction circuit made under license from Dolby Laboratories Licensing Corporation.

The DC voltage is an actual reading measured with a high impedance type voltmeter with a cassette loaded at playback mode. The measurement value may vary depending on the measuring instruments used or on the product. Bias circuit DC voltage is measured while in the record mode.

KRF-X7775D/X7775D-S/VR-5080/5090

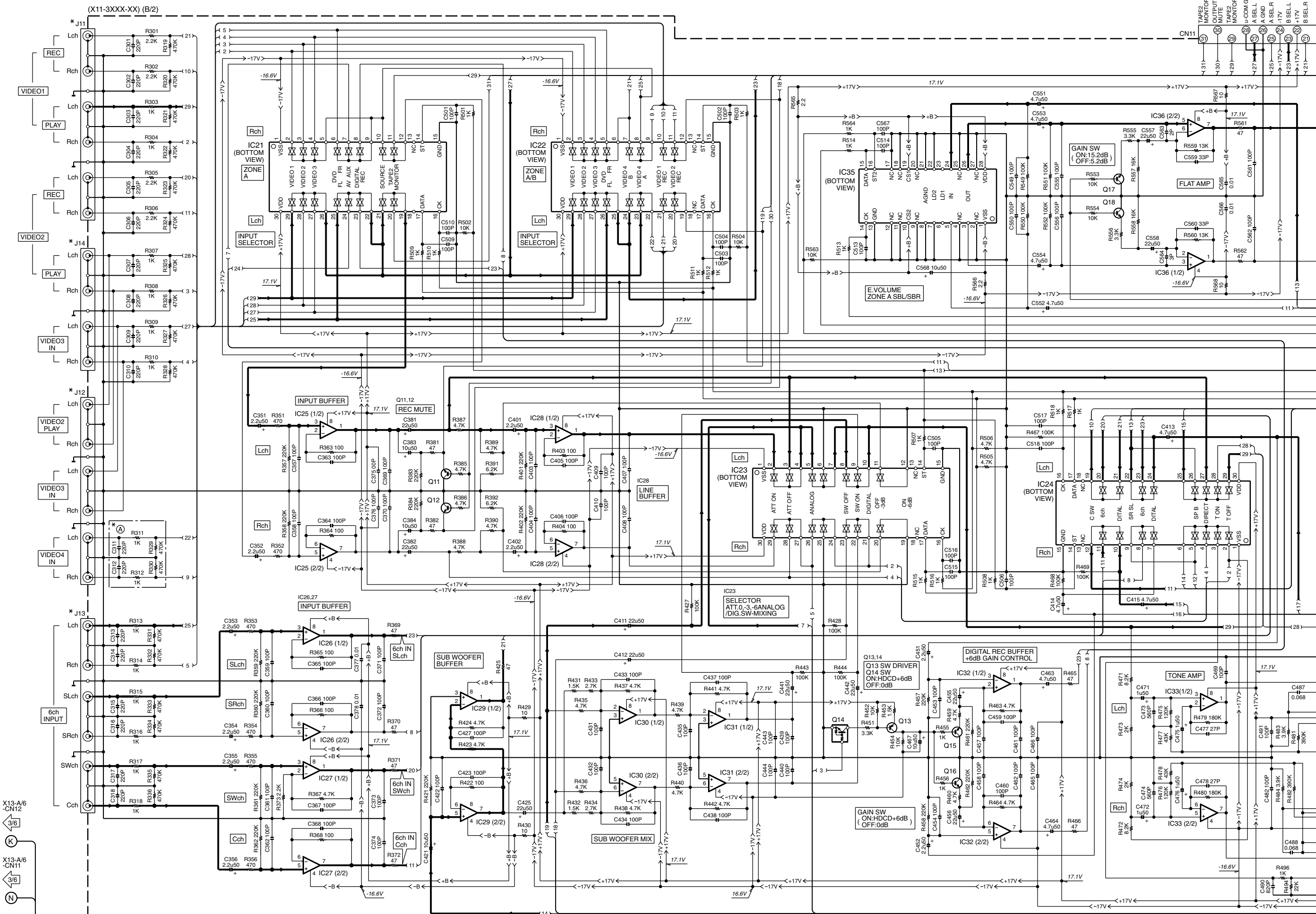

(X11-3XXX-XX) (B/2)

2
3
4
5
6
7

X13-A/6
-CN12
3/6
K
X13-A/6
-CN11
3/6
N

CN11
TAPED MONITOR L
OUTPUT
TAPED MONITOR
A SEL L
A SEL R
B SEL L
B SEL R

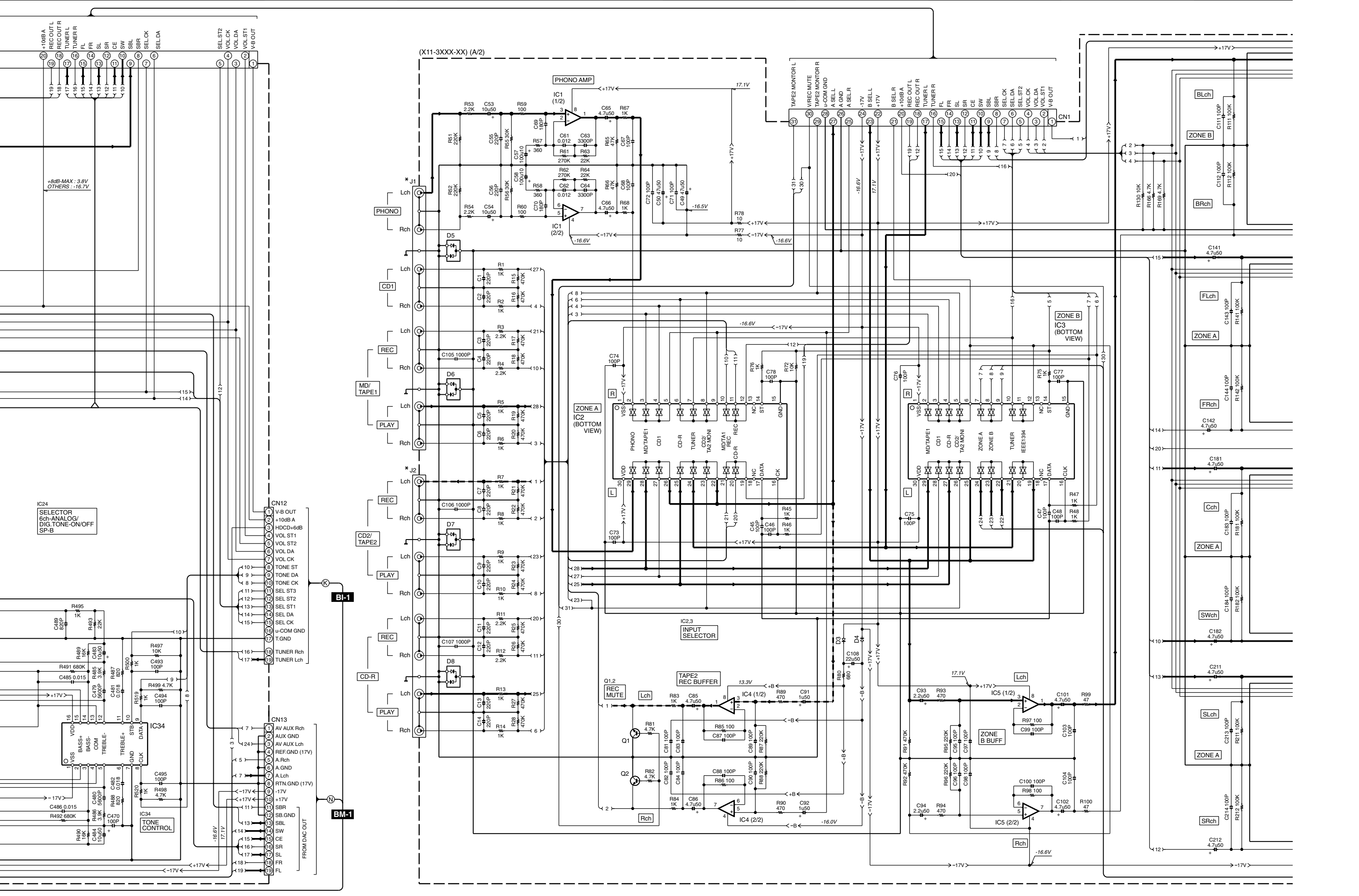

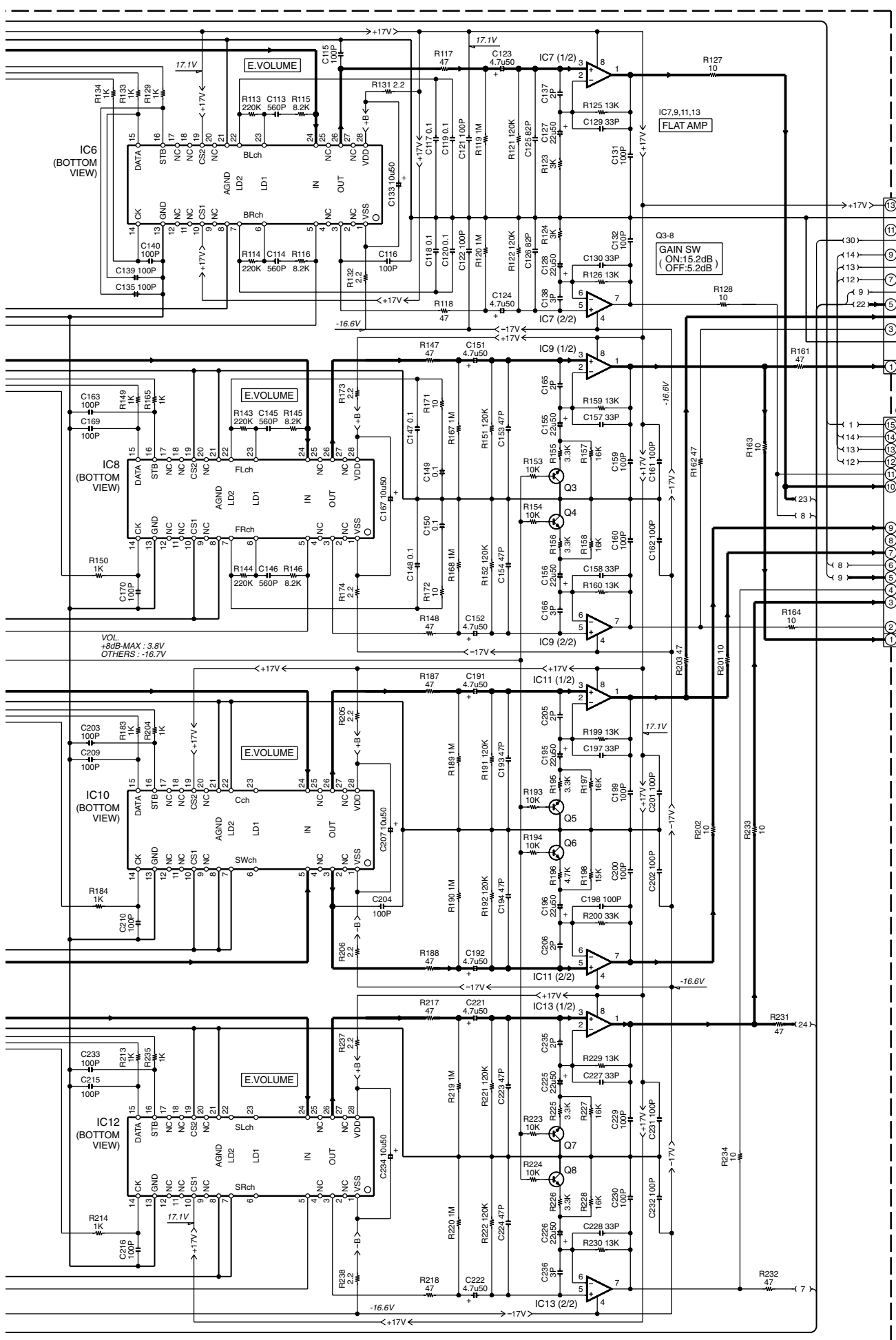

- IC1 : NJM4580ED
- IC2,21 : NJU7312AM
- IC3,22,24 : NJU7313AM
- IC4,5,7,29,33,36 : NJM4565M
- IC6,8,10,12 : TC9459N
- IC9,11,13,25-28 : NJM4565MD
- IC23 : NJU7311AM
- IC34 : TC9184AP
- IC35 : TC9459N
- Q1-8,11,12,15-18 : 2SC2878 (B)
- Q13 : 2SA1576A (R,S) or 2SA1586 (Y,GR)
- Q14 : DT1242EUA or UN5212
- D3,4 : MA111
- D5-8 : DA204U or 1SS302

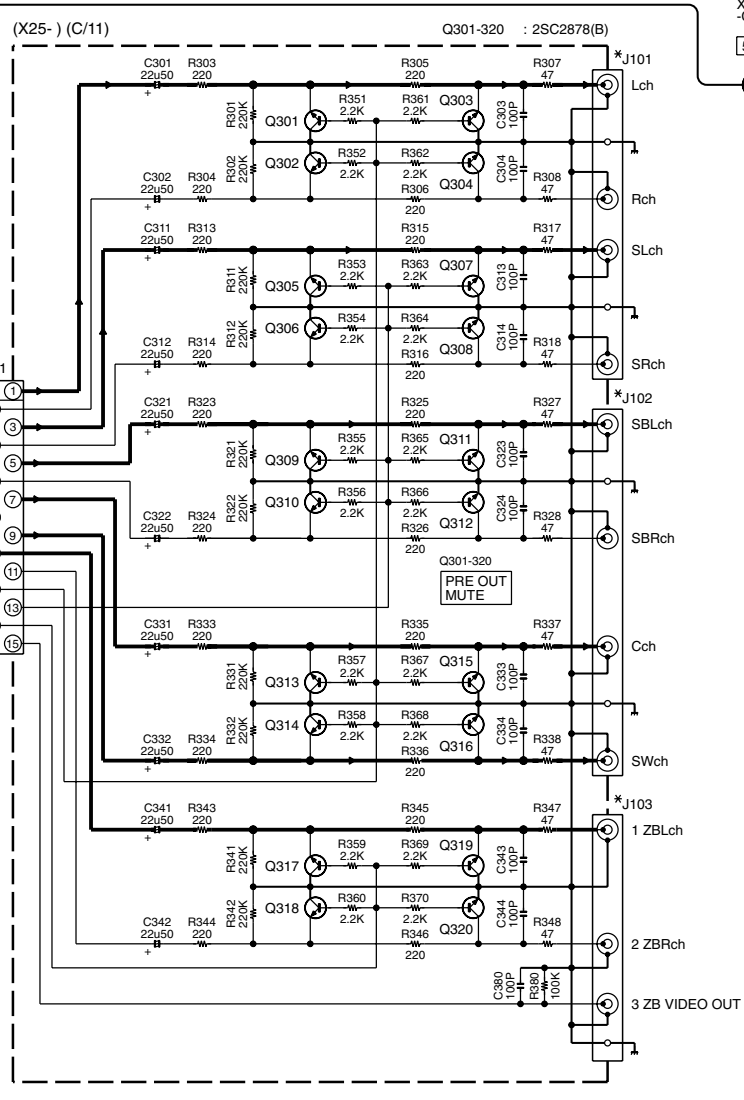
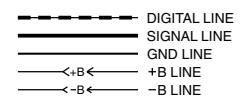

VR-5080 (X25-6410-10)

DESTINATION	UNIT	J101	J102	J103
COUNTRY	ABB.	No.		
U.S.A.	K	E63-1173-05 (NI)	E63-1174-05 (NI)	E63-1178-05 (NI)
CANADA	P1	0-10		

VR-5090 (X25-6410-11)

DESTINATION	UNIT	J101	J102	J103
COUNTRY	ABB.	No.		
U.S.A.	K1	E63-1176-05 (GOLD)	E63-1177-05 (GOLD)	E63-1179-05 (GOLD)
CANADA	P2	0-11		

KRF-X7775D (X25-641X-XX)

DESTINATION	UNIT	J101	J102	J103
COUNTRY	ABB.	No.		
EUROPE	E1	2-71	E63-1173-05 (NI)	E63-1174-05 (NI)
				E63-1178-05 (NI)

KRF-X7775D-S (X25-64XX-XX)

DESTINATION	UNIT	J101	J102	J103
COUNTRY	ABB.	No.		
PX	Y1	12-71		
EUROPE	E2	E63-1173-05 (NI)	E63-1174-05 (NI)	E63-1178-05 (NI)
GENERAL MARKET	M1	10-21		
AUSTRALIA	X1			
SHANGHAI	V	22-10		

VR-5080/5090 (4/6)
KRF-X7775D/X7775D-S (4/6)

VR-5080 (X11-3890-10)

DESTINATION	UNIT	J1,2	J11	J12	J13	J14
COUNTRY	ABB.	No.				
U.S.A.	K	NO	E63-1112-05	E63-1164-05	NO	E63-1114-05
CANADA	P1	0-10				E63-1163-05

VR-5090 (X11-3890-11)

DESTINATION	UNIT	J1,2	J11,12	J13	J14	
COUNTRY	ABB.	No.				
U.S.A.	K1	0-11	YES	E63-1113-05	E63-1111-05	NO
CANADA	P2					

KRF-X7775D (X11-3890-XX)

DESTINATION	UNIT	J1,2	J11	J12	J13	J14
COUNTRY	ABB.	No.				
EUROPE	E1	0-10	NO	E63-1112-05	E63-1164-05	NO
						E63-1114-05
						E63-1163-05

KRF-X7775D-S (X11-3XXX-XX)

DESTINATION	UNIT	J1,2	J11	J12	J13	J14
COUNTRY	ABB.	No.				
PX	Y1	890-10	NO	E63-1112-05	E63-1164-05	NO
GENERAL MARKET	M1					
AUSTRALIA	X1					E63-1114-05
EUROPE	E2					
SHANGHAI	V	902-10				

CAUTION: For continued safety, replace safety critical components only with manufacturer's recommended parts (refer to parts list). ⚠ indicates safety critical components. For continued protection against risk of fire, replace only with same type and rating fuse(s). To reduce the risk of electric shock, leakage-current or resistance measurements shall be carried out (exposed parts are acceptably insulated from the supply circuit) before the appliance is returned to the customer.

The DC voltage is an actual reading measured with a high impedance type voltmeter with a cassette loaded at playback mode. The measurement value may vary depending on the measuring instruments used or on the product. Bias circuit DC voltage is measured while in the record mode.

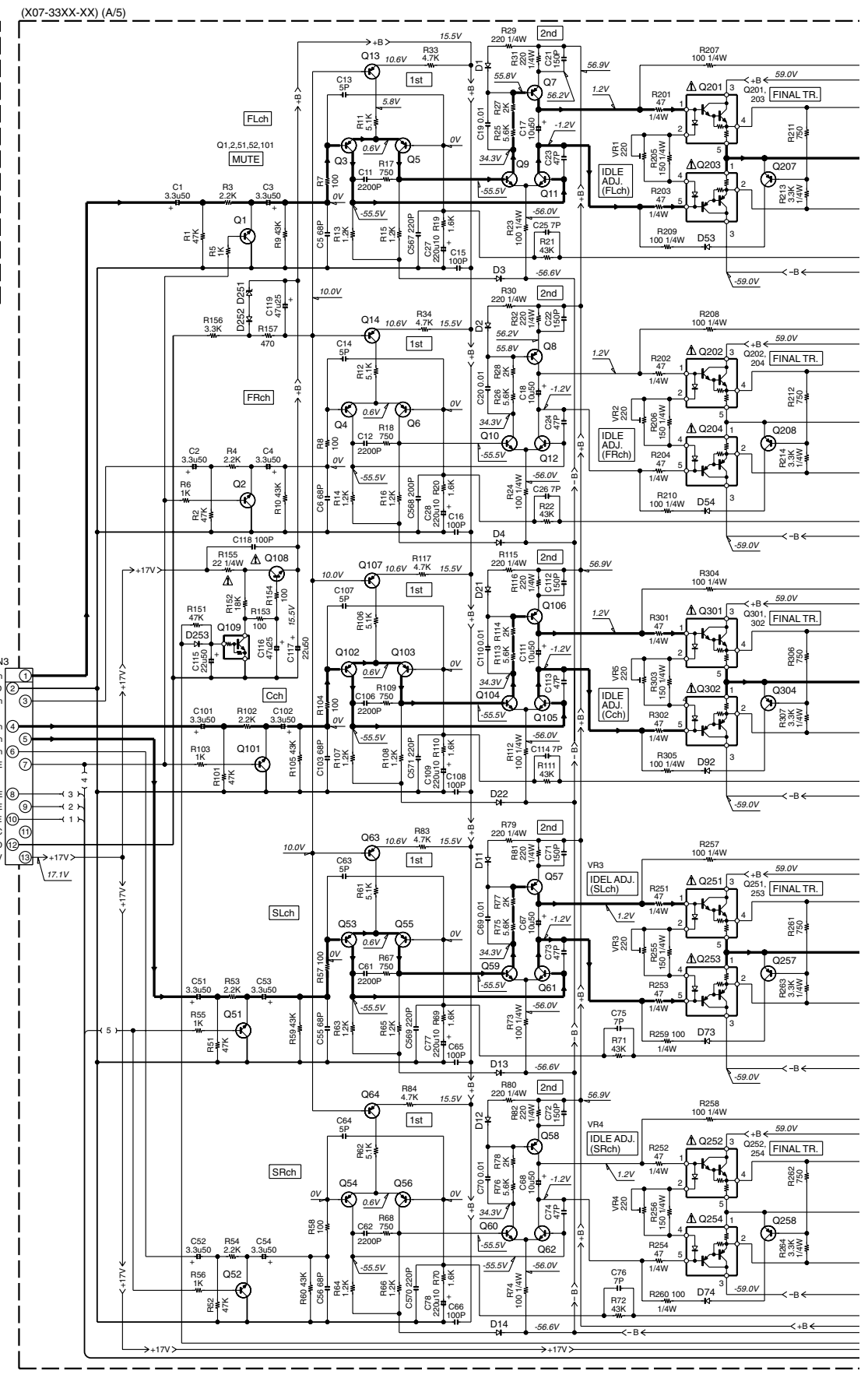
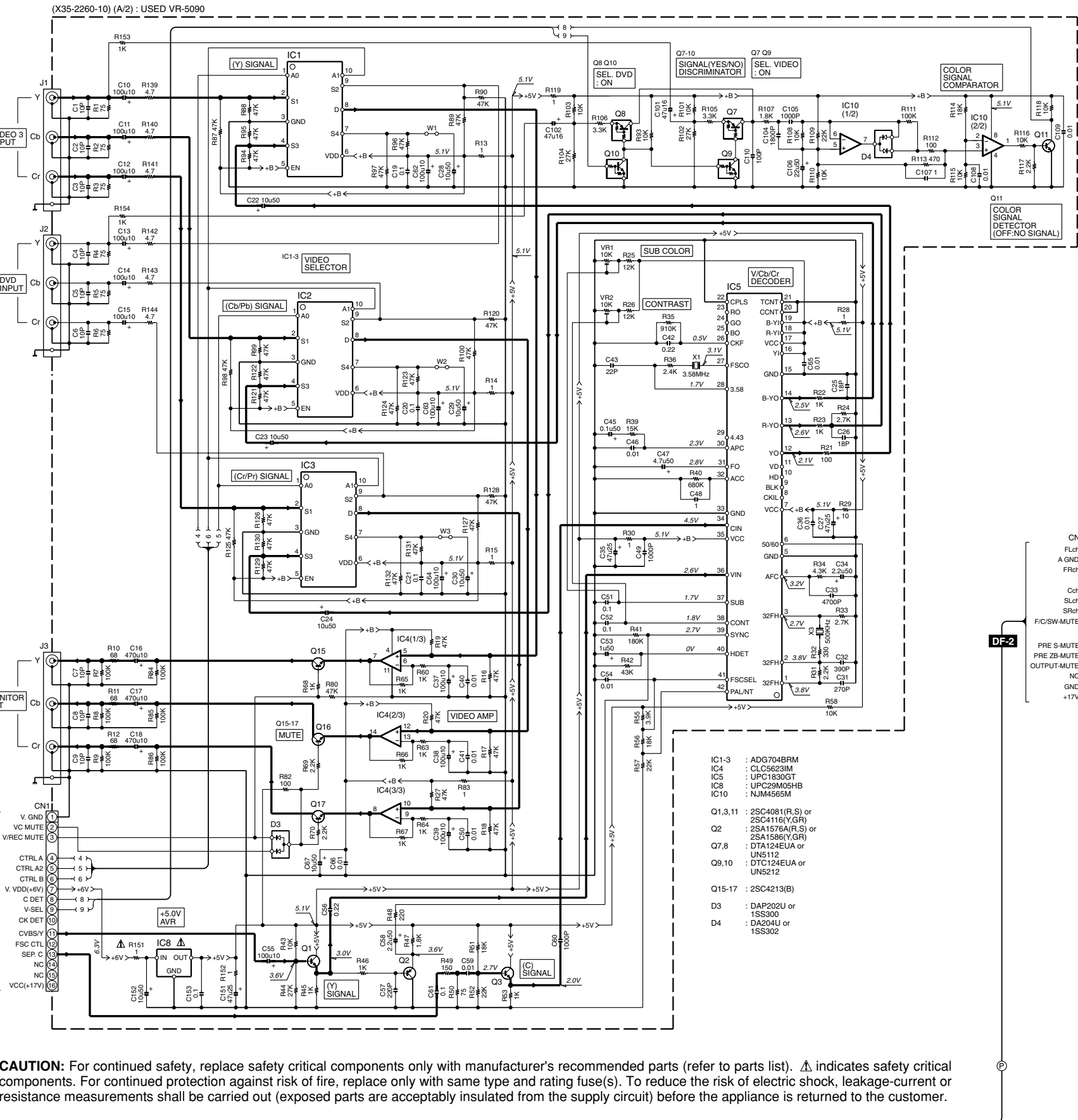

The DC voltage is an actual reading measured with a high impedance type voltmeter with a cassette loaded at playback mode. The measurement value may vary depending on the measuring instruments used or on the product. Bias circuit DC voltage is measured while in the record mode.

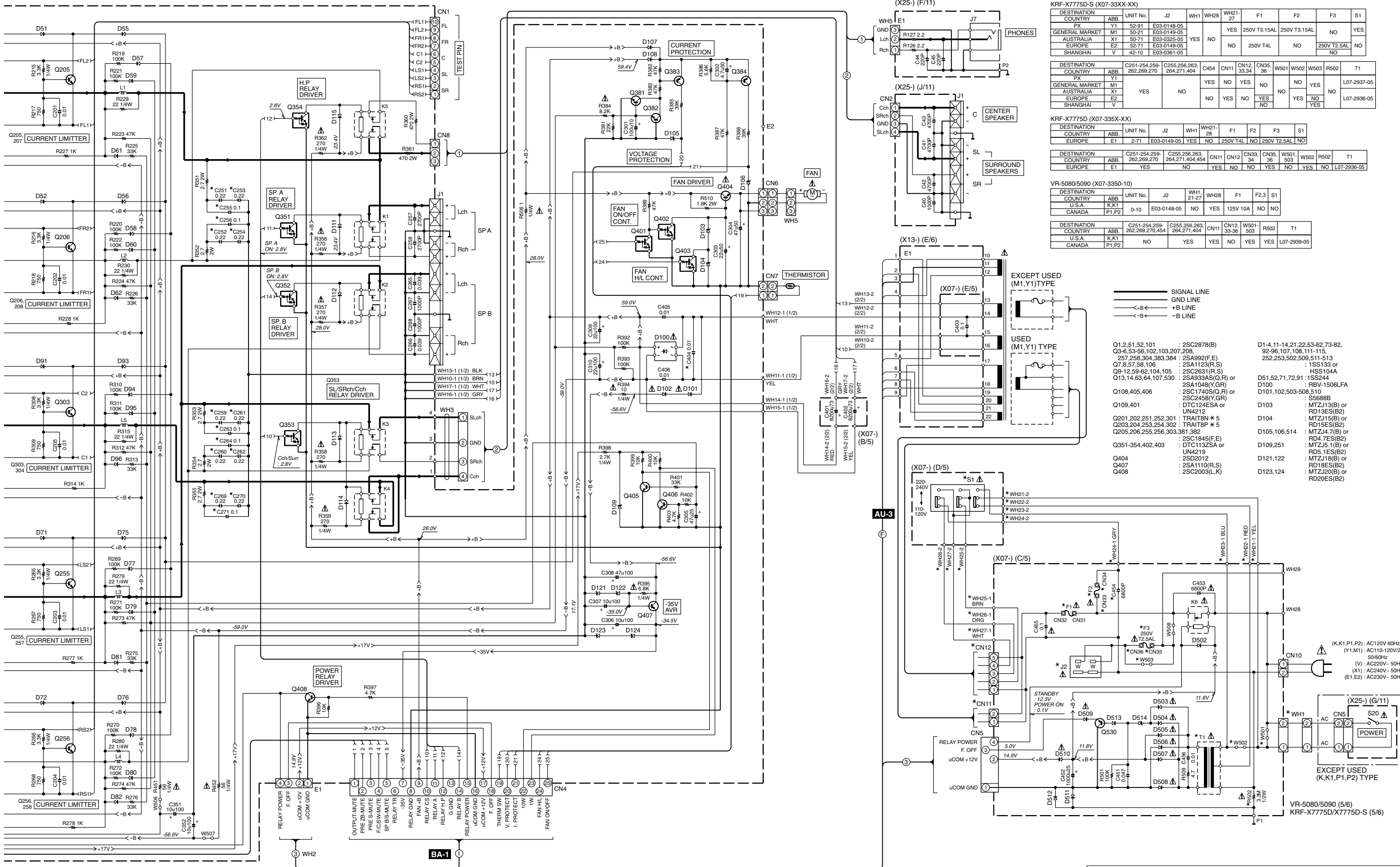

KRF-X7775D-S (X07-33XX-XX)

DESTINATION	COUNTRY	ABB.	UNIT No.	J2	WH1	WH28	WH21-27	F1	F2	F3	S1
GENERAL MARKET	PX	Y1	52-91	E03-0148-05			YES	250V T3.15AL	250V T3.15AL	NO	YES
GENERAL MARKET	AUSTRALIA	X1	50-21	E03-0149-05			NO	250V T4L	NO	250V T2.5AL	NO
GENERAL MARKET	EUROPE	E2	52-71	E03-0149-05			NO	250V T4L	NO	250V T2.5AL	NO
GENERAL MARKET	SHANGHAI	V	42-10	E03-0361-05			NO	250V T4L	NO	250V T2.5AL	NO

KRF-X7775D (X07-335X-XX)

DESTINATION	COUNTRY	ABB.	UNIT No.	J2	WH1	WH21-28	F1	F2	F3	S1	
GENERAL MARKET	PX	Y1	52-91	E03-0148-05			YES	250V T3.15AL	250V T3.15AL	NO	YES
GENERAL MARKET	AUSTRALIA	X1	50-21	E03-0325-05			NO	250V T4L	NO	250V T2.5AL	NO
GENERAL MARKET	EUROPE	E2	52-71	E03-0149-05			NO	250V T4L	NO	250V T2.5AL	NO
GENERAL MARKET	SHANGHAI	V	42-10	E03-0361-05			NO	250V T4L	NO	250V T2.5AL	NO

KRF-X7775D (X07-335X-XX)

DESTINATION	COUNTRY	ABB.	UNIT No.	J2	WH1	WH21-28	F1	F2	F3	S1	
GENERAL MARKET	PX	Y1	52-91	E03-0148-05			YES	250V T3.15AL	250V T3.15AL	NO	YES
GENERAL MARKET	AUSTRALIA	X1	50-21	E03-0325-05			NO	250V T4L	NO	250V T2.5AL	NO
GENERAL MARKET	EUROPE	E2	52-71	E03-0149-05			NO	250V T4L	NO	250V T2.5AL	NO
GENERAL MARKET	SHANGHAI	V	42-10	E03-0361-05			NO	250V T4L	NO	250V T2.5AL	NO

VR-5080/5090 (X07-3350-10)

DESTINATION	COUNTRY	ABB.	UNIT No.	J2	WH1	WH21-27	F1	F2,3	S1	
GENERAL MARKET	PX	Y1	52-91	E03-0148-05			YES	125V 10A	NO	NO
GENERAL MARKET	U.S.A.	K,K1	0-10	E03-0148-05			NO	125V 10A	NO	NO
GENERAL MARKET	CANADA	P1,P2	0-10	E03-0148-05			NO	125V 10A	NO	NO

VR-5080/5090 (X07-3350-10)

DESTINATION	COUNTRY	ABB.	UNIT No.	J2	WH1	WH21-27	F1	F2,3	S1	
GENERAL MARKET	PX	Y1	52-91	E03-0148-05			YES	125V 10A	NO	NO
GENERAL MARKET	U.S.A.	K,K1	0-10	E03-0148-05			NO	125V 10A	NO	NO
GENERAL MARKET	CANADA	P1,P2	0-10	E03-0148-05			NO	125V 10A	NO	NO

VR-5080/5090 (X07-3350-10)

DESTINATION	COUNTRY	ABB.	UNIT No.	J2	WH1	WH21-27	F1	F2,3	S1	
GENERAL MARKET	PX	Y1	52-91	E03-0148-05			YES	125V 10A	NO	NO
GENERAL MARKET	U.S.A.	K,K1	0-10	E03-0148-05			NO	125V 10A	NO	NO
GENERAL MARKET	CANADA	P1,P2	0-10	E03-0148-05			NO	125V 10A	NO	NO

- EXCEPT USED (M1,Y1) TYPE
- USED (M1,Y1) TYPE
- Q1,2,51,52,101 : 2SC2878(B)
 - Q3,6,53,56,102,103,207,208, 257,258,304,383,384 : 2SA992(F,E)
 - Q7,8,57,58,106 : 2SA1123(R,S)
 - Q9,12,59,62,104,105 : 2SC2631(R,S)
 - Q13,14,63,64,107,530 : 2SA933A(S,Q,R) or 2SA1048(Y,G,R)
 - Q108,405,406 : 2SC1740S(Q,R) or 2SC2458(Y,G,R)
 - Q109,401 : UN4219
 - Q201,202,251,252,301 : TRAIT8N * 5
 - Q203,204,253,254,302 : TRAIT8P * 5
 - Q205,206,255,256,303,381,382 : 2SC1845(F,E)
 - Q351-354,402,403 : DTC124ESA or UN4219
 - Q404 : 2SD2012
 - Q407 : 2SA1110(R,S)
 - Q408 : 2SC2003(L,K)
 - D1-4,11-14,21,22,53-62,73-82, 92-96,107,108,111-115, 252,253,502,509,511-513 : 1SS133 or HSS104A
 - D100 : RBV-1506/LFA
 - D101,102,503-508,510 : S5688B
 - D103 : MTZJ13(B) or RD13ES(B2)
 - D104 : MTZJ15(B) or RD15ES(B2)
 - D105,106,514 : MTZJ4.7(B) or RD4.7ES(B2)
 - D109,251 : MTZJ5.1(B) or RD5.1ES(B2)
 - D121,122 : MTZJ18(B) or RD18ES(B2)
 - D123,124 : MTZJ20(B) or RD20ES(B2)

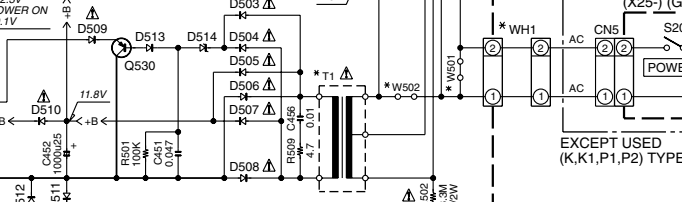
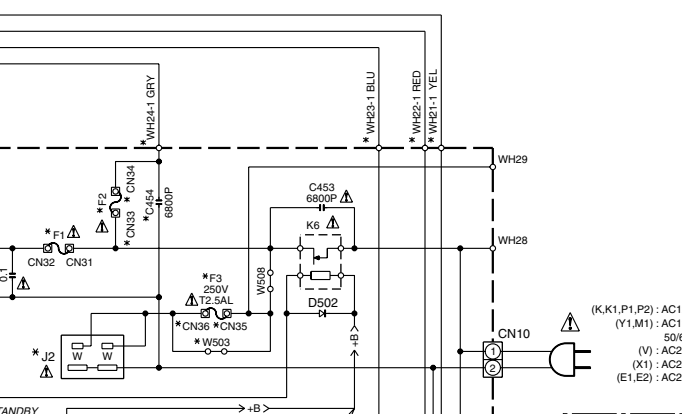

VR-5080/5090 (5/6)
KRF-X7775D/X7775D-S (5/6)

KRF-X7775D/X7775D-S/VR-5080/5090

IC401 : TC4W53FU
 D403,408,411 : DA204U or 1SS302
 Q401,414,416,417 : 2SC4081(R,S) or 2SC4116(Y,GR)
 D410,412-414 : 1SS133 or HSS104A
 Q402,413,418 : DTC124EUA or UN5212
 Q412,415 : 2SA1576A(R,S) or 2SA1586(Y,GR)
 Q419 : DTA124EUA or UN5112

(X25-) (B/11)

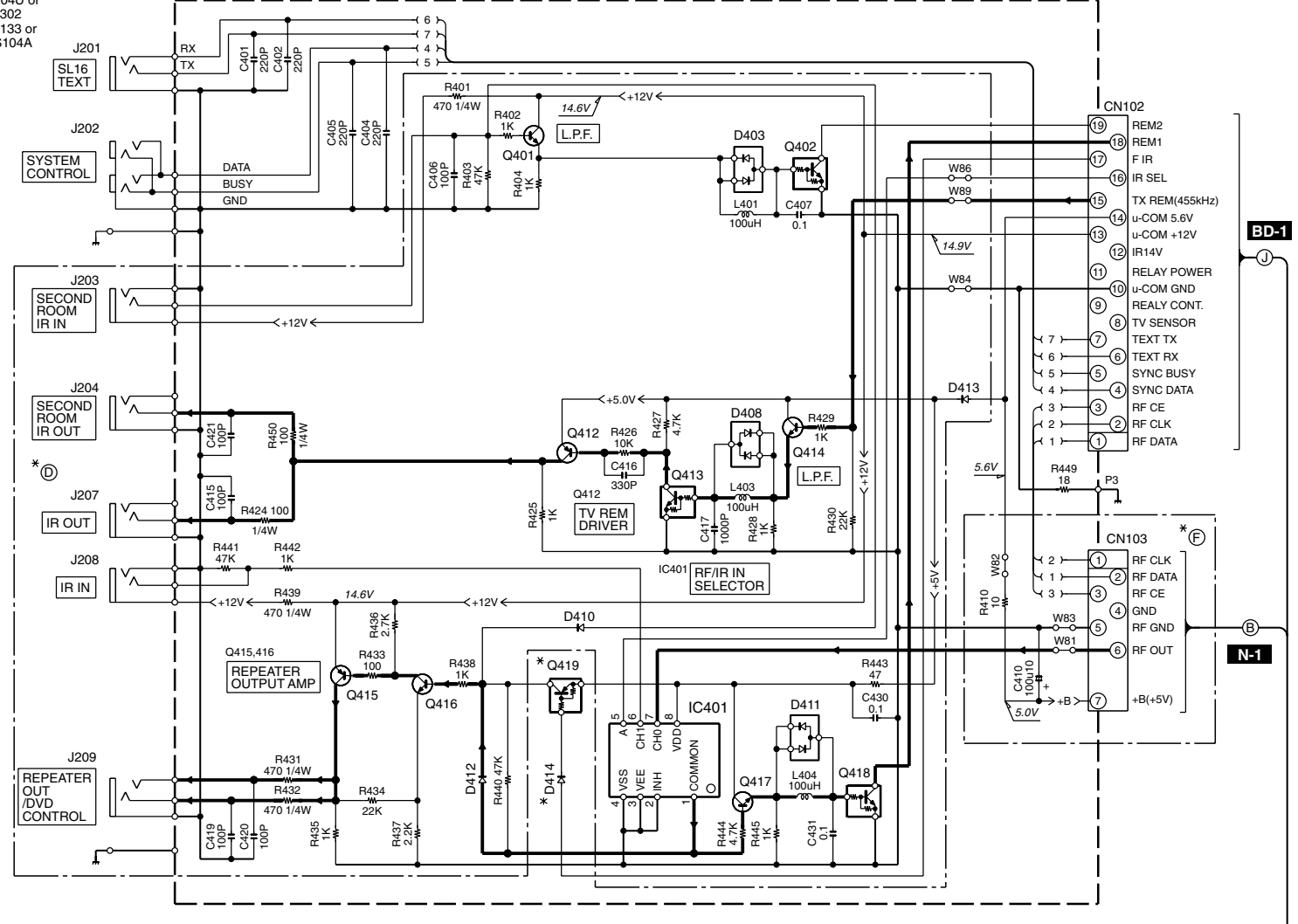

VR-5080 (X25-6410-10)

DESTINATION	UNIT	(B)	(C)	(D)	(F)	D11	D15-18, 24,25	D414	Q419	R6	R82-85, 91,92	R241-244	W95
COUNTRY	ABB.	No.											
U.S.A.	K	0-10	NO	YES		B30-2548-05 (GREEN)	B30-2573-05 (RED)	NO	NO	150	270	YES	YES
CANADA	P1												

VR-5090 (X25-6410-11)

DESTINATION	UNIT	(B)	(C)	(D)	(F)	D11	D15-18, 24,25	D414	Q419	R6	R82-85, 91,92	R241-244	W95
COUNTRY	ABB.	No.											
U.S.A.	K1	0-11	YES			B30-2548-05 (GREEN)	B30-2573-05 (RED)	NO	NO	150	270	NO	NO
CANADA	P2												

KRF-X7775D (X25-641X-XX)

DESTINATION	UNIT	(B)	(C)	(F)	(D)	D11	D15-18, 24,25	D414	Q419	R6	R82-85, 91,92	R241-244	S18	W95
COUNTRY	ABB.	No.												
EUROPE	E1	2-71	NO	YES		B30-2548-05 (GREEN)	B30-2573-05 (RED)	YES	YES	150	270	YES	NO	YES

KRF-X7775D-S (X25-64XX-XX)

DESTINATION	UNIT	(B)	(C)	(F)	(D)	D11	D15-18, 24,25	D414	Q419	R6	R82-85, 91,92	R241-244	W95	
COUNTRY	ABB.	No.												
EUROPE	Y1	12-71			YES	B30-2548-05 (GREEN)	B30-2573-05 (RED)	YES	YES	150	270	YES	YES	
GENERAL MARKET	M1	10-21	NO		NO								YES	YES
AUSTRALIA	X1				NO	B30-2571-05 (BLUE)	B30-2571-05 (BLUE)	NO	NO	220	220			
SHANGHAI	V1	22-10												

(X25-) (E/11) D27,28 : DA204U or 1SS302

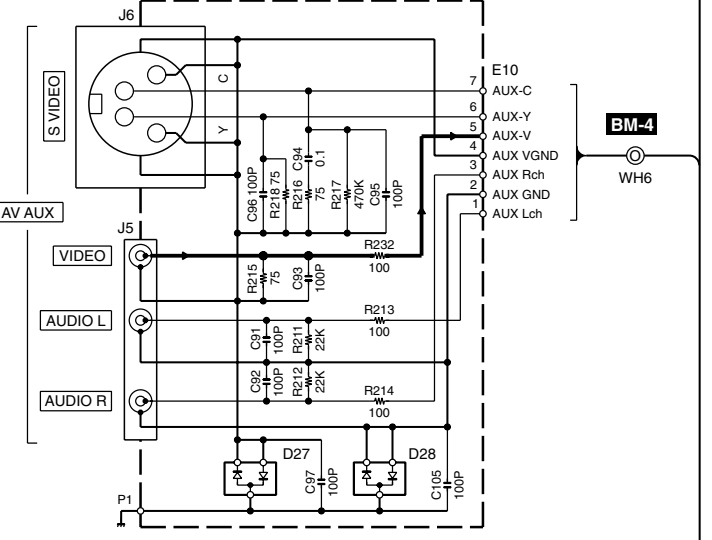

(X25-64XX-XX) (A/11)

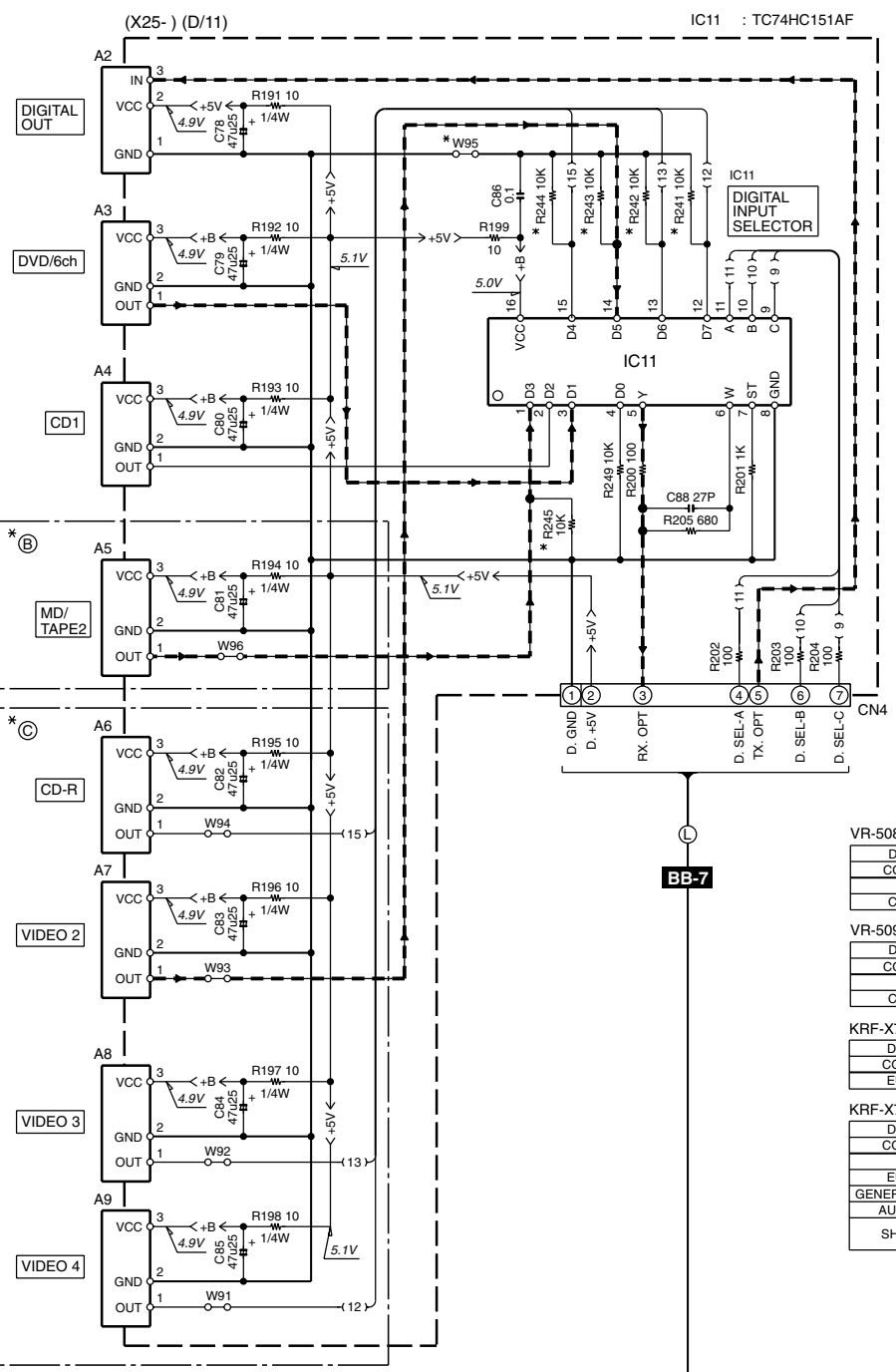
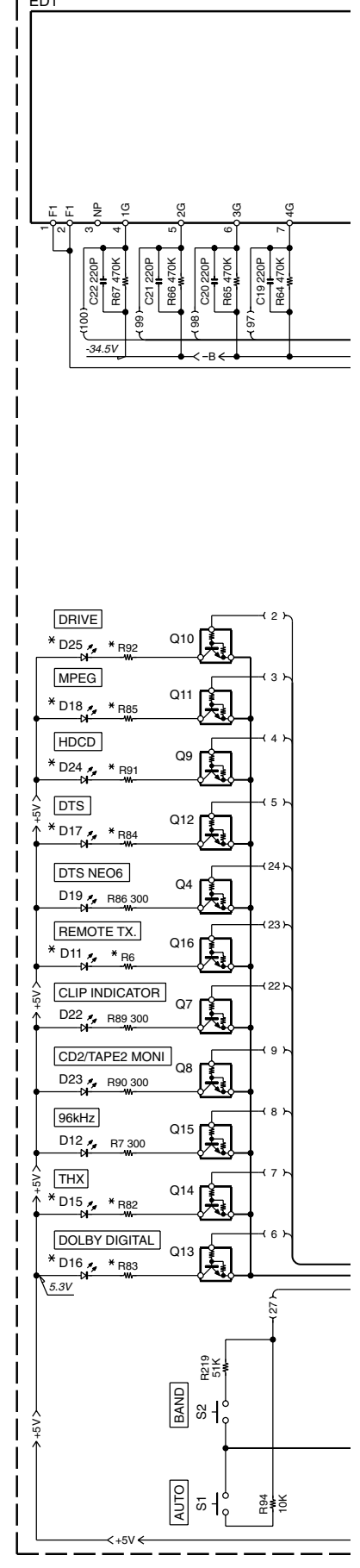

- X05-510 -CN1
- X13-A/6 -CN1
- X13-A/6 -CN2
- X13-A/6 -CN13
- X13-A/6 -CN7
- X13-A/6 -CN3

BB-7

BM-4

BD-1

N-1

BAND

AUTO

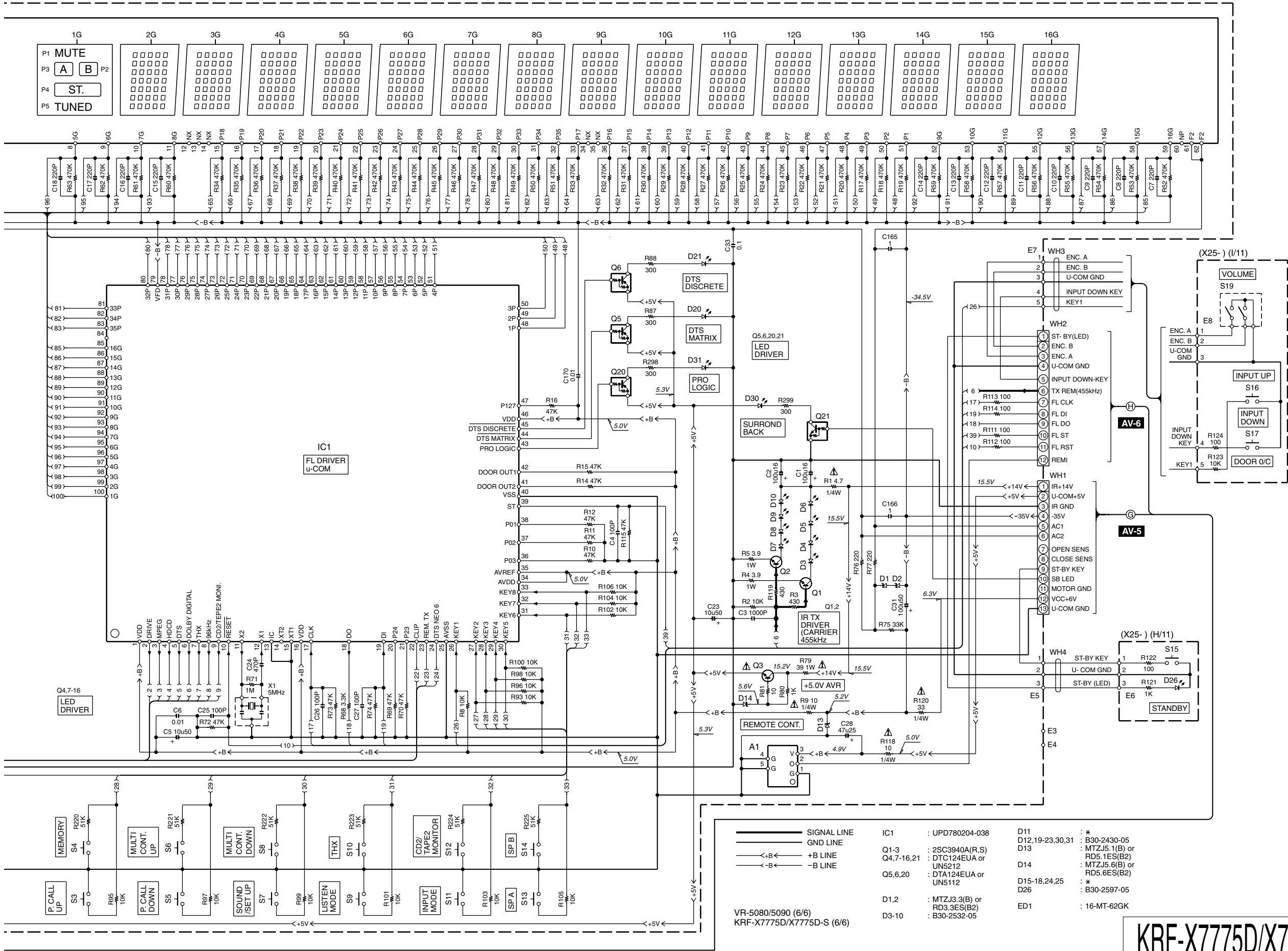

CAUTION: For continued safety, replace safety critical components only with manufacturer's recommended parts (refer to parts list). Δ indicates safety critical components. For continued protection against risk of fire, replace only with same type and rating fuse(s). To reduce the risk of electric shock, leakage-current or resistance measurements shall be carried out (exposed parts are acceptably insulated from the supply circuit) before the appliance is returned to the customer.

The DC voltage is an actual reading measured with a high impedance type voltmeter with a cassette loaded at playback mode. The measurement value may vary depending on the measuring instruments used or on the product. Bias circuit DC voltage is measured while in the record mode.

- SIGNAL LINE
 - - - - - GND LINE
 ———> +B LINE
 ———< -B LINE
- IC1 : UPD780204-038
 Q1-3 : 2SC3940A(R,S)
 Q4,7-16,21 : DTC124EUA or UN5212
 Q5,6,20 : DTA124EUA or UN5112
 D1,2 : MTJ3.3(B) or RD3.3ES(B2)
 D3-10 : B30-2532-05
 D11 : *
 D12,19-23,30,31 : B30-2430-05
 D13 : MTJ5.1(B) or RD5.1ES(B2)
 D14 : MTJ5.6(B) or RD5.6ES(B2)
 D15-18,24,25 : *
 D26 : B30-2597-05
 ED1 : 16-MT-62GK

VR-5080/5090 (6/6)
KRF-X7775D/X7775D-S (6/6)

KRF-X7775D/X7775D-S/VR-5080/5090

Y05-4210-10

KENWOOD

EXPLODED VIEW (UNIT)

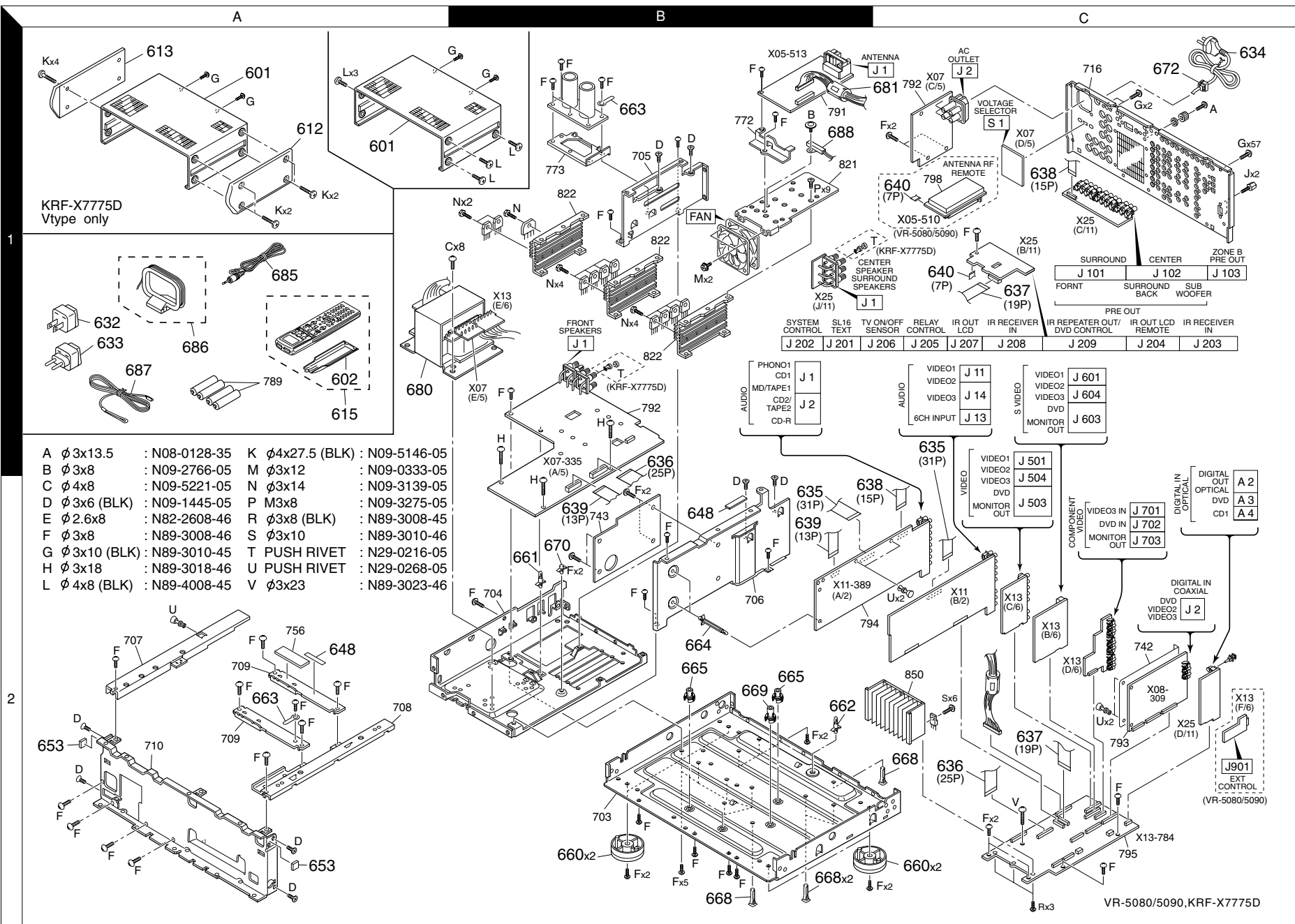

- | | | | |
|---------------------|---------------|-----------------------|---------------|
| A ϕ 3x13.5 | : N08-0128-35 | K ϕ 4x27.5 (BLK) | : N09-5146-05 |
| B ϕ 3x8 | : N09-2766-05 | M ϕ 3x12 | : N09-0333-05 |
| C ϕ 4x8 | : N09-5221-05 | N ϕ 3x14 | : N09-3139-05 |
| D ϕ 3x6 (BLK) | : N09-1445-05 | P M3x8 | : N09-3275-05 |
| E ϕ 2.6x8 | : N82-2608-46 | R ϕ 3x8 (BLK) | : N89-3008-45 |
| F ϕ 3x8 | : N89-3008-46 | S ϕ 3x10 | : N89-3010-46 |
| G ϕ 3x10 (BLK) | : N89-3010-45 | T PUSH RIVET | : N29-0216-05 |
| H ϕ 3x18 | : N89-3018-46 | U PUSH RIVET | : N29-0268-05 |
| L ϕ 4x8 (BLK) | : N89-4008-45 | V ϕ 3x23 | : N89-3023-46 |

D

E

F

- D ϕ 3x6 (BLK) : N09-1445-05
- E ϕ 2.6x8 : N82-2608-46
- F ϕ 3x8 : N89-3008-46

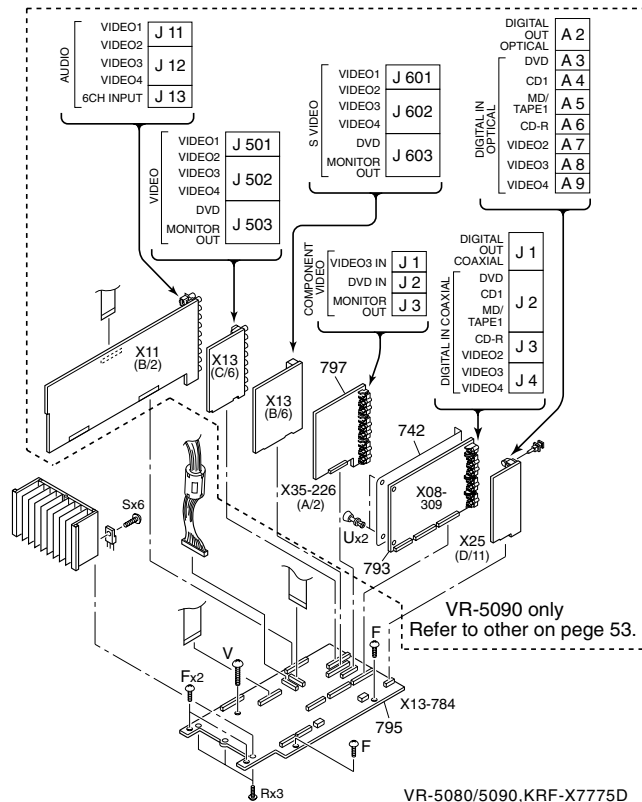
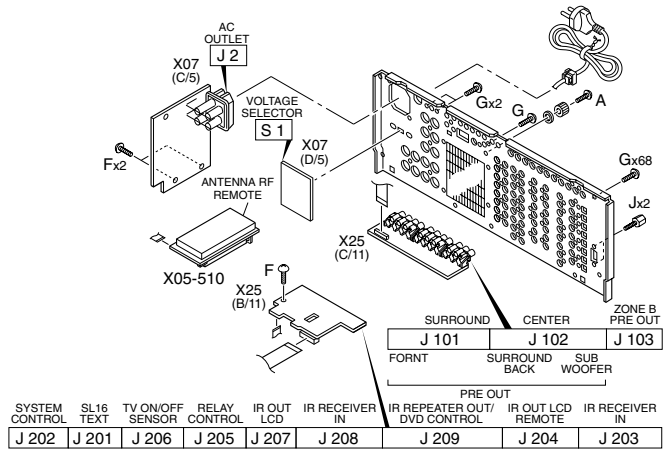
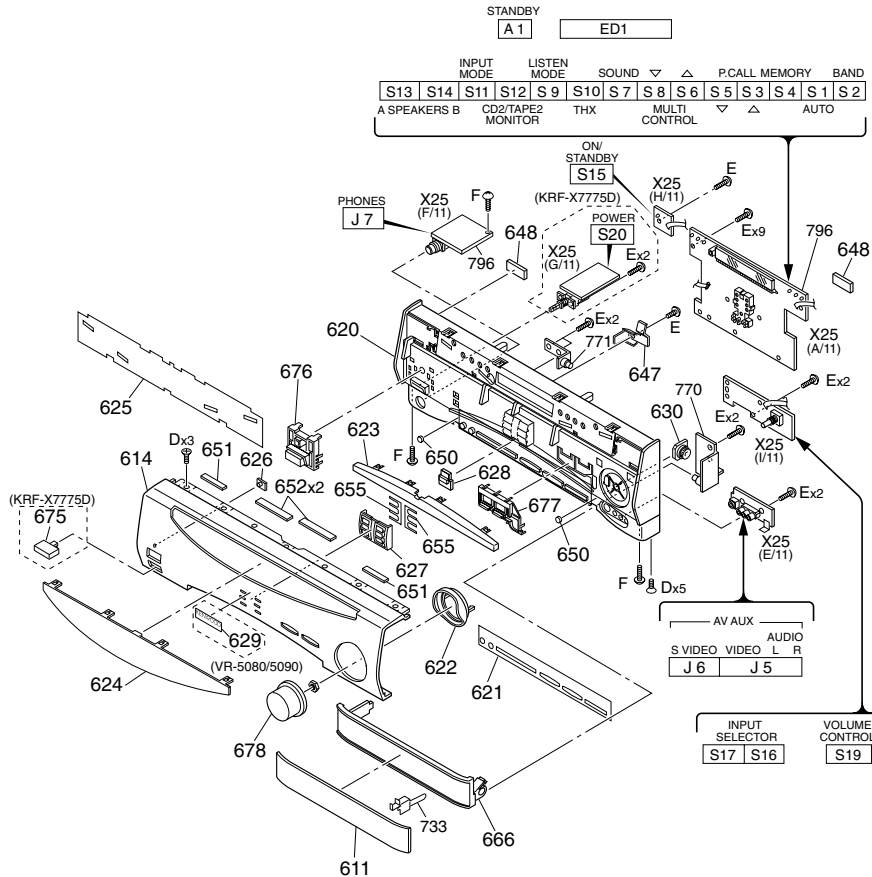

Parts with exploded numbers larger than 700 are not supplied.

* New Parts

Parts without **Parts No.** are not supplied.Les articles non mentionnés dans le **Parts No.** ne sont pas fournis.Teile ohne **Parts No.** werden nicht geliefert.

①

Ref. No	Add-ress	New Parts	Parts No.	Description	Desti-nation	Re-marks
KRF-X7775D/KRF-X7775D-S/VR-5080/VR-5090						
601	1A	*	A01-3802-01	METALLIC CABINET	M1X1E2	
601	1A	*	A01-3803-01	METALLIC CABINET	V	
601	1A	*	A01-3804-01	METALLIC CABINET	KP1K1	
601	1A	*	A01-3804-01	METALLIC CABINET	P2E1Y1	
602	1A		A09-1166-08	BATTERY COVER		
611	2D	*	A29-1137-03	PANEL	M1X1	
611	2D	*	A29-1138-03	PANEL	KP1K1	
611	2D	*	A29-1138-03	PANEL	P2Y1	
611	2D	*	A29-1139-03	PANEL	E2	
611	2D	*	A29-1140-03	PANEL	E1	
612	1A		A50-1344-02	SIDE PLATE R	V	
613	1A		A50-1345-02	SIDE PLATE L	V	
614	1D	*	A60-1959-02	PANEL	KP1	
614	1D	*	A60-1960-02	PANEL	K1P2	
614	1D	*	A60-1961-02	PANEL	M1X1E2	
614	1D	*	A60-1963-02	PANEL	E1Y1	
614	1D	*	A60-2014-02	PANEL	V	
615	1A	*	A70-1453-05	REMOTE CONTROL ASSY(RC-R0913)	KP1K1	
615	1A	*	A70-1453-05	REMOTE CONTROL ASSY(RC-R0913)	P2	
615	1A	*	A70-1454-05	REMOTE CONTROL ASSY(RC-R0914)	V	
615	1A	*	A70-1454-05	REMOTE CONTROL ASSY(RC-R0914)	Y1M1X1	
615	1A	*	A70-1455-05	REMOTE CONTROL ASSY(RC-R0915)	E1E2	
620	1D	*	B01-0543-11	PANEL ESCUTCHEON	KP1K1	
620	1D	*	B01-0543-11	PANEL ESCUTCHEON	P2E1Y1	
620	1D	*	B01-0544-11	PANEL ESCUTCHEON	M1X1E2	
620	1D	*	B01-0544-11	PANEL ESCUTCHEON	V	
621	2D	*	B03-3874-03	DRESSING PLATE	KP1K1	
621	2D	*	B03-3874-03	DRESSING PLATE	P2	
621	2D	*	B03-3875-03	DRESSING PLATE	M1X1E2	
621	2D	*	B03-3875-03	DRESSING PLATE	V	
621	2D	*	B03-3877-03	DRESSING PLATE	E1Y1	
622	2D		B07-2495-04	ESCUTCHEON	M1X1E2	
622	2D		B07-2495-04	ESCUTCHEON	V	
622	2D		B07-2496-04	ESCUTCHEON	KP1K1	
622	2D		B07-2496-04	ESCUTCHEON	P2E1Y1	
623	1D		B10-3570-03	FRONT GLASS		
624	2D	*	B10-3639-02	FRONT GLASS		
625	1D	*	B11-1528-03	COLOR FILTER		
626	1D		B12-0390-04	INDICATOR		
627	2D		B12-0391-14	INDICATOR		
628	1D		B12-0392-14	INDICATOR		
629	2D	*	B43-0322-04	KENWOOD BADGE	KP1K1	
629	2D	*	B43-0322-04	KENWOOD BADGE	P2	
-			B46-0096-53	WARRANTY CARD	X1	
-			B46-0310-03	WARRANTY CARD	E1E2	
-			B46-0330-03	WARRANTY CARD	Y1	
-		*	B46-0331-03	WARRANTY CARD	KK1	
-			B46-0344-03	WARRANTY CARD	V	
-		*	B46-0358-00	QUESTIONNAIRE CARD	KK1	
-		*	B46-0359-03	WARRANTY CARD	P1P2	
-			B58-0513-04	CAUTION CARD (PRESET220-240)	Y1	
-			B58-0964-13	CAUTION CARD (UL)	KK1Y1	

L : Scandinavia K : USA P : Canada R : Mexico C : China I : Malaysia
 Y : PX(Far East,Hawaii) T : England E : Europe G : Germany V : China(Shanghai)
 Y : AAFES(Europe) X : Australia Q : Russia H : Korea M : Other Areas Δ indicates safety critical components.

* New Parts

Parts without **Parts No.** are not supplied.Les articles non mentionnés dans le **Parts No.** ne sont pas fournis.Teile ohne **Parts No.** werden nicht geliefert.

②

Ref. No	Add-ress	New Parts	Parts No.	Description	Desti-nation	Re-marks
-			B58-0965-13	CAUTION CARD (T_XtypePL)	X1	
-			B58-0966-13	CAUTION CARD (ELMtypePL)	E1M1E2	
-			B58-0967-03	CAUTION CARD (PtypePL)	P1P2	
-			B58-1546-03	CAUTION CARD	V	
-			B59-1104-00	SERVICE DIRECTORY	Y1	
-		*	B60-4861-00	INSTRUCTION MANUAL (EN1)	KP1K1	
-		*	B60-4861-00	INSTRUCTION MANUAL (EN1)	P2	
-		*	B60-4862-00	INSTRUCTION MANUAL (FR1)	P1P2	
-		*	B60-4863-00	INSTRUCTION MANUAL (EN1)	Y1M1X1	
-		*	B60-4864-00	INSTRUCTION MANUAL (FR1)	E2	
-		*	B60-4865-00	INSTRUCTION MANUAL (GE1)	E1E2	
-		*	B60-4866-00	INSTRUCTION MANUAL (NE1)	E1E2	
-		*	B60-4867-00	INSTRUCTION MANUAL (IT1)	E2	
-		*	B60-4868-00	INSTRUCTION MANUAL (ES1)	E2	
-		*	B60-4869-00	INSTRUCTION MANUAL (TC1)	M1	
-		*	B60-4870-00	INSTRUCTION MANUAL (AR1)	M1	
-		*	B60-4872-00	INSTRUCTION MANUAL (EN2)	KP1K1	
-		*	B60-4872-00	INSTRUCTION MANUAL (EN2)	P2	
-		*	B60-4873-00	INSTRUCTION MANUAL (FR2)	P1P2	
-		*	B60-4874-00	INSTRUCTION MANUAL (EN2)	Y1M1X1	
-		*	B60-4875-00	INSTRUCTION MANUAL (FR2)	E2	
-		*	B60-4876-00	INSTRUCTION MANUAL (GE2)	E1E2	
-		*	B60-4877-00	INSTRUCTION MANUAL (NE2)	E1E2	
-		*	B60-4878-00	INSTRUCTION MANUAL (IT2)	E2	
-		*	B60-4879-00	INSTRUCTION MANUAL (ES2)	E2	
-		*	B60-4880-00	INSTRUCTION MANUAL (TC2)	M1	
-		*	B60-4881-00	INSTRUCTION MANUAL (AR2)	M1	
-		*	B60-5035-00	INSTRUCTION MANUAL (SC1)	V	
-		*	B60-5036-00	INSTRUCTION MANUAL (SC2)	V	
630	1E		D39-0347-05	DAMPER		
Δ 632	1A	*	E03-0382-05	AC PLUG ADAPTER (WA-6)	M1	
Δ 633	1A	*	E03-0383-05	AC PLUG ADAPTER (WA-9C)	M1	
Δ 634	1C		E30-2789-05	AC POWER CORD	Y1	
Δ 634	1C		E30-2790-05	AC POWER CORD	X1	
Δ 634	1C		E30-2824-15	AC POWER CORD	V	
Δ 634	1C		E30-2943-05	AC POWER CORD	E1E2	
Δ 634	1C		E30-2944-05	AC POWER CORD	KP1K1	
Δ 634	1C		E30-2944-05	AC POWER CORD	P2	
Δ 634	1C	*	E30-7225-05	AC POWER CORD	M1	
635	2B,1C	*	E35-2757-05	FLAT CABLE (31P)		
636	2B,2C	*	E35-2758-05	FLAT CABLE (25P)		
637	1C,2C	*	E35-2759-05	FLAT CABLE (19P)		
638	1C,2C	*	E35-2760-05	FLAT CABLE (15P)		
639	2B	*	E35-2761-05	FLAT CABLE (13P)		
640	1C	*	E35-2762-05	FLAT CABLE (7P)	KP1K1	
640	1C	*	E35-2762-05	FLAT CABLE (7P)	P2	
647	1E		G02-1701-04	FLAT SPRING		
648	1B,1E		G10-0541-04	NON-WOVEN FABRIC		
650	1D,2E		G11-2719-04	CUSHION		
651	1D		G11-2730-04	SOFT TAPE		
652	1D		G11-2731-04	SOFT TAPE		
653	2A		G11-2743-14	CUSHION		
655	2D		G11-2762-04	CUSHION	V	

L : Scandinavia K : USA P : Canada R : Mexico C : China I : Malaysia
 Y : PX(Far East,Hawaii) T : England E : Europe G : Germany V : China(Shanghai)
 Y : AAFES(Europe) X : Australia Q : Russia H : Korea M : Other Areas Δ indicates safety critical components.

* New Parts
Parts without **Parts No.** are not supplied.
Les articles non mentionnés dans le **Parts No.** ne sont pas fournis.
Teile ohne **Parts No.** werden nicht geliefert.

3

Ref. No	Add-ress	New Parts	Parts No.	Description	Desti-nation	Re-marks
-			H10-7636-12	POLYSTYRENE FOAMED FIXTURE,L	KP1K1	
-			H10-7636-12	POLYSTYRENE FOAMED FIXTURE,L	P2E1	
-			H10-7636-12	POLYSTYRENE FOAMED FIXTURE,L	X1Y1	
-		*	H10-7637-22	POLYSTYRENE FOAMED FIXTURE,R	KP1K1	
-		*	H10-7637-22	POLYSTYRENE FOAMED FIXTURE,R	P2E1	
-			H10-7637-22	POLYSTYRENE FOAMED FIXTURE,R	X1Y1	
-			H10-7638-22	POLYSTYRENE FOAMED FIXTURE,L	V	
-			H10-7639-32	POLYSTYRENE FOAMED FIXTURE,R	V	
-		*	H10-7755-12	POLYSTYRENE FOAMED FIXTURE,L	M1E2	
-		*	H10-7756-22	POLYSTYRENE FOAMED FIXTURE,R	M1E2	
-			H12-3527-04	PACKING FIXTURE	M1E2	
-		*	H13-0050-04	CARTON BOARD	M1E2	
-		*	H13-0330-14	CARTON BOARD		
-		*	H13-0341-04	CARTON BOARD	KP1K1	
-		*	H13-0341-04	CARTON BOARD	P2	
-			H21-0388-04	PROTECTION SHEET	V	
-		*	H25-0232-04	PROTECTION BAG (235X350X0.03)	KP1K1	
-		*	H25-0232-04	PROTECTION BAG (235X350X0.03)	P2E1Y1	
-		*	H25-0232-04	PROTECTION BAG (235X350X0.03)	X1V	
-		*	H25-0632-24	PROTECTION BAG (250X400)	M1E2	
-			H25-0692-04	PROTECTION BAG	E1E2	
-			H25-0692-04	PROTECTION BAG	M1X1Y1	
-			H25-1671-04	PROTECTION BAG	V	
-		*	H25-1710-04	PROTECTION BAG (500X950)	KP1K1	
-		*	H25-1710-04	PROTECTION BAG (500X950)	P2	
-			H50-3941-04	ITEM CARTON CASE	KP1	
-		*	H50-3942-04	ITEM CARTON CASE	K1P2	
-		*	H50-3943-04	ITEM CARTON CASE	E1	
-		*	H50-4074-04	ITEM CARTON CASE	V	
-		*	H50-4150-04	ITEM CARTON CASE	Y1	
-			H50-4151-04	ITEM CARTON CASE	X1	
-		*	H50-4219-04	ITEM CARTON CASE	M1	
-		*	H50-4220-04	ITEM CARTON CASE	E2	
660	2B,2C		J02-1467-03	FOOT (D=60,H=21.5)		
661	2B		J19-5910-05	UNIT HOLDER		
662	2B		J19-5911-05	UNIT HOLDER		
663	2A,1B		J19-0306-05	LEAD HOLDER		
664	2B		J19-5919-05	UNIT HOLDER		
665	2B		J19-6002-04	UNIT HOLDER		
666	2E		J19-6053-12	HOLDER	M1X1E2	
666	2E		J19-6068-12	HOLDER	KP1K1	
666	2E		J19-6068-12	HOLDER	P2E1Y1	
668	2B,2C	*	J19-6163-05	HOLDER		
669	2B	*	J19-6203-04	UNIT HOLDER		
670	2B	*	J19-6080-05	UNIT HOLDER		
672	1C		J42-0083-05	POWER CORD BUSHING	Y1X1	
672	1C		J42-0157-05	POWER CORD BUSHING	E2	
672	1C		J42-0157-05	POWER CORD BUSHING	KP1K1	
672	1C		J42-0157-05	POWER CORD BUSHING	P2E1M1	
-			J61-0307-05	WIRE BAND		
675	2D		K27-2388-04	KNOB (BUTTON)	M1X1E2	
675	2D		K27-2388-04	KNOB (BUTTON)	V	
675	2D		K27-2398-04	KNOB (BUTTON)	E1Y1	
676	1D		K29-7727-04	KNOB	M1X1E2	

L : Scandinavia K : USA P : Canada R : Mexico C : China I : Malaysia
Y : PX(Far East,Hawaii) T : England E : Europe G : Germany V : China(Shanghai)
Y : AAFES(Europe) X : Australia Q : Russia H : Korea M : Other Areas Δ indicates safety critical components .

* New Parts
Parts without **Parts No.** are not supplied.
Les articles non mentionnés dans le **Parts No.** ne sont pas fournis.
Teile ohne **Parts No.** werden nicht geliefert.

4

Ref. No	Add-ress	New Parts	Parts No.	Description	Desti-nation	Re-marks
676	1D		K29-7727-04	KNOB	V	
676	1D		K29-7729-04	KNOB	KP1K1	
676	1D		K29-7729-04	KNOB	P2E1Y1	
677	2E		K29-7739-13	KNOB	M1X1E2	
677	2E		K29-7739-13	KNOB	V	
677	2E		K29-7740-13	KNOB	KP1K1	
677	2E		K29-7740-13	KNOB	P2E1Y1	
678	2D		K29-7742-04	KNOB	M1X1E2	
678	2D		K29-7742-04	KNOB	V	
678	2D		K29-7743-04	KNOB	KP1K1	
678	2D		K29-7743-04	KNOB	P2E1Y1	
Δ 680	1A	*	L07-2941-05	POWER TRANSFORMER	KP1K1	
Δ 680	1A	*	L07-2941-05	POWER TRANSFORMER	P2	
Δ 680	1A	*	L07-2942-05	POWER TRANSFORMER	E1E2	
Δ 680	1A	*	L07-2943-05	POWER TRANSFORMER	Y1M1	
Δ 680	1A	*	L07-2944-05	POWER TRANSFORMER	X1	
Δ 680	1A	*	L07-2950-05	POWER TRANSFORMER	V	
681	1C	*	L92-0533-05	FERRITE CORE		
682	2C	*	L92-0531-05	FERRITE CORE		
685	1A	*	T90-0850-15	ANTENNA ASSY	KP1K1	
685	1A	*	T90-0850-15	ANTENNA ASSY	P2	
686	1A	*	T90-0852-05	LOOP ANTENNA		
687	1A	*	T90-0855-05	LEAD WIRE ANTENNA		
688	1B	*	DP40203SG270	THERMISTOR		
RF-RC DEMODULATOR UNIT (X05-5100-11) K,P type only						
C1	.2		CC73GCH1H100D	CHIP C	10PF	D
C5			CK73GB1E223K	CHIP C	0.022UF	K
C6			CC73GCH1H221J	CHIP C	220PF	J
C7			CC73GCH1H100D	CHIP C	10PF	D
C8			CK73GB1H102K	CHIP C	1000PF	K
C9			C93-0037-05	CERAMIC	10UF	10WV
C10			CK73GB1H102K	CHIP C	1000PF	K
C11			CC73GCH1H040C	CHIP C	4.0PF	C
C12			CC73GCH1H100D	CHIP C	10PF	D
C13			CC73GCH1H040C	CHIP C	4.0PF	C
C14			CC73GCH1H010C	CHIP C	1.0PF	C
C15			CC73GCH1H050C	CHIP C	5.0PF	C
C16			CK73GB1E223K	CHIP C	0.022UF	K
C17			CC73GCH1H221J	CHIP C	220PF	J
C18			CC73GCH1H100D	CHIP C	10PF	D
C19			CC73GCH1H471J	CHIP C	470PF	J
C20			C93-0037-05	CERAMIC	10UF	10WV
C21			CK73GB1H102K	CHIP C	1000PF	K
C22	.23		CC73GCH1H150J	CHIP C	15PF	J
C24			CK73GB1H102K	CHIP C	1000PF	K
C25			CK73GB1E103K	CHIP C	0.010UF	K
C26			CK73GF1A474Z	CHIP C	0.47UF	Z
C27			C93-0036-05	CHIP-C	4.7UF	Z
C28			CK73GB1E103K	CHIP C	0.010UF	K
C29			CC73GCH1H101J	CHIP C	100PF	J
C30			CK73GB1E103K	CHIP C	0.010UF	K
C31			C93-0037-05	CERAMIC	10UF	10WV
C32			CK73GB1C473K	CHIP C	0.047UF	K

L : Scandinavia K : USA P : Canada R : Mexico C : China I : Malaysia
Y : PX(Far East,Hawaii) T : England E : Europe G : Germany V : China(Shanghai)
Y : AAFES(Europe) X : Australia Q : Russia H : Korea M : Other Areas Δ indicates safety critical components .

PARTS LIST

KRF-X7775D/X7775D-S/VR-5080/5090

* New Parts

Parts without **Parts No.** are not supplied.Les articles non mentionnés dans le **Parts No.** ne sont pas fournis.Teile ohne **Parts No.** werden nicht geliefert.

5

Ref. No	Add-ress	New Parts	Parts No.	Description	Desti-nation	Re-marks
C33			C93-0036-05	CHIP-C 4.7UF Z		
C34			CC73GCH1H471J	CHIP C 470PF J		
C35			CK73GB1E103K	CHIP C 0.010UF K		
C36			CK73GF1C224Z	CHIP C 0.22UF Z		
C37			CC73GCH1H100D	CHIP C 10PF D		
C38			CK73GB1H472K	CHIP C 4700PF K		
C39			CC73GCH1H331J	CHIP C 330PF J		
C40			CK73GB1E103K	CHIP C 0.010UF K		
C41			C93-0036-05	CHIP-C 4.7UF Z		
C42			C93-0037-05	CERAMIC 10UF 10WV		
C43			C93-0039-05	CERAMIC 22UF 10WV		
CN1			E40-8530-05	FLAT CABLE CONNECTOR		
J1			E11-0904-05	MINIATURE PHONE JACK(STEREO MI)		
CF1			L72-0626-05	CERAMIC FILTER		
L1			L79-1269-05	LC FILTER		
L2			L40-1585-67	SMALL FIXED INDUCTOR(150N,J,20)		
L3			L32-1021-05	FM OSCILLATING COIL		
L4			L40-1085-67	SMALL FIXED INDUCTOR(100N,J,20)		
X1			L77-2274-05	CRYSTAL RESONATOR		
R1			RK73GB1J431J	CHIP R 430 J 1/16W		
R2			RK73GB1J120J	CHIP R 12 J 1/16W		
R3			RK73GB1J431J	CHIP R 430 J 1/16W		
R10			RK73GB1J331J	CHIP R 330 J 1/16W		
R11			RK73GB1J391J	CHIP R 390 J 1/16W		
R12			RK73GB1J100J	CHIP R 10 J 1/16W		
R13			RK73GB1J470J	CHIP R 47 J 1/16W		
R14			RK73GB1J473J	CHIP R 47K J 1/16W		
R15			RK73GB1J2R2J	CHIP R 2.2 J 1/16W		
R16			RK73GB1J100J	CHIP R 10 J 1/16W		
R17			RK73GB1J101J	CHIP R 100 J 1/16W		
R18			RK73GB1J184J	CHIP R 180K J 1/16W		
R19			RK73GB1J471J	CHIP R 470 J 1/16W		
R20 ,21			RK73GB1J100J	CHIP R 10 J 1/16W		
R22 -24			RK73GB1J102J	CHIP R 1.0K J 1/16W		
R25			RK73GB1J472J	CHIP R 4.7K J 1/16W		
R26			RK73GB1J101J	CHIP R 100 J 1/16W		
R27			RK73GB1J152J	CHIP R 1.5K J 1/16W		
R28			RK73GB1J681J	CHIP R 680 J 1/16W		
R29 -31			RK73GB1J102J	CHIP R 1.0K J 1/16W		
R32			RK73GB1J152J	CHIP R 1.5K J 1/16W		
R33			RK73GB1J102J	CHIP R 1.0K J 1/16W		
R34 ,35			RK73GB1J222J	CHIP R 2.2K J 1/16W		
R36 ,37			RK73GB1J101J	CHIP R 100 J 1/16W		
R38			RK73GB1J222J	CHIP R 2.2K J 1/16W		
R39			RK73GB1J472J	CHIP R 4.7K J 1/16W		
R40			RK73GB1J104J	CHIP R 100K J 1/16W		
R41			RK73GB1J472J	CHIP R 4.7K J 1/16W		
R42			RK73GB1J101J	CHIP R 100 J 1/16W		
R43 ,44			RK73GB1J103J	CHIP R 10K J 1/16W		
R45			RK73GB1J105J	CHIP R 1.0M J 1/16W		
R46			RK73GB1J562J	CHIP R 5.6K J 1/16W		
R47 -49			RK73GB1J472J	CHIP R 4.7K J 1/16W		
R50			RK73GB1J101J	CHIP R 100 J 1/16W		

L : Scandinavia K : USA P : Canada R : Mexico C : China I : Malaysia

Y : PX(Far East,Hawaii) T : England E : Europe G : Germany V : China(Shanghai)

Y : AAFES(Europe) X : Australia Q : Russia H : Korea M : Other Areas Δ indicates safety critical components .

* New Parts

Parts without **Parts No.** are not supplied.Les articles non mentionnés dans le **Parts No.** ne sont pas fournis.Teile ohne **Parts No.** werden nicht geliefert.

6

Ref. No	Add-ress	New Parts	Parts No.	Description	Desti-nation	Re-marks
R51			RK73GB1J473J	CHIP R 47K J 1/16W		
R52			RK73GB1J103J	CHIP R 10K J 1/16W		
R53			RK73GB1J472J	CHIP R 4.7K J 1/16W		
R54			RK73GB1J101J	CHIP R 100 J 1/16W		
D1 ,2			MA111	DIODE		
D3			KV1832E	VARIABLE CAPACITANCE DIODE		
D4			MA111	DIODE		
IC1			UPC1687G	ANALOGUE IC		
IC2			LV2105V	MOS-IC		
IC3			UPC2748T-E3	ANALOGUE IC		
Q3			2SC5065(O,Y)	TRANSISTOR		
Q4 -6			2SC4178(F13,14)	TRANSISTOR		
Q7			2SA1576A(R,S)	TRANSISTOR		
Q7			2SB1218A(Q,R)	TRANSISTOR		
Q8 -10			2SC4081(R,S)	TRANSISTOR		
Q8 -10			2SD1819A(Q,R)	TRANSISTOR		
Q11 ,12			2SA1576A(R,S)	TRANSISTOR		
Q11 ,12			2SB1218A(Q,R)	TRANSISTOR		
TUNER UNIT (X05-513/514X-XX)						
C1			CK73FB1H332K	CHIP C 3300PF K		
C2			CK73FB1H103K	CHIP C 0.010UF K		E1E2
C3			CK73FB1H103K	CHIP C 0.010UF K		
C5 ,6			CK73FB1H103K	CHIP C 0.010UF K		
C7			CE04KW1C470M	ELECTRO 47UF 16WV		
C10			CE04KW1C470M	ELECTRO 47UF 16WV		
C11 ,12			CK73FB1H473K	CHIP C 0.047UF K		
C14			CE04KW1H100M	ELECTRO 10UF 50WV		
C15			CE04KW1H010M	ELECTRO 1.0UF 50WV		
C16			CE04RW1HR47M	ELECTRO 0.47UF 50WV		
C17			CE04KW1H010M	ELECTRO 1.0UF 50WV		
C18			CC73FCH1H470J	CHIP C 47PF J		
C19			CE04RW1A100M	ELECTRO 10UF 10WV		
C20			CK73FB1H473K	CHIP C 0.047UF K		
C21			CE04RW1V3R3M	ELECTRO 3.3UF 35WV		
C22			CK73FB1H473K	CHIP C 0.047UF K		
C23			CE04KW1H100M	ELECTRO 10UF 50WV		
C24			CC73FCH1H331J	CHIP C 330PF J		
C25			CC73FCH1H181J	CHIP C 180PF J		KP1K1
C25			CC73FCH1H181J	CHIP C 180PF J		P2E1E2
C25			CC73FCH1H331J	CHIP C 330PF J		V
C25			CC73FCH1H331J	CHIP C 330PF J		Y1M1X1
C26			CK73FB1H183K	CHIP C 0.018UF K		
C27			CE04HW1E4R7M	NP-ELEC 4.7UF 25WV		
C28 ,29			CE04KW1H2R2M	ELECTRO 2.2UF 50WV		
C30 ,31			CK73FB1H223K	CHIP C 0.022UF K		E1Y1M1
C30 ,31			CK73FB1H223K	CHIP C 0.022UF K		X1E2V
C30 ,31			CK73FB1H333K	CHIP C 0.033UF K		KP1K1
C30 ,31			CK73FB1H333K	CHIP C 0.033UF K		P2
C32			CE04KW1H4R7M	ELECTRO 4.7UF 50WV		
C33 ,34			CK73FB1H103K	CHIP C 0.010UF K		Y1M1V
C36			CK73FB1H103K	CHIP C 0.010UF K		
C37 ,38			CE04KW1H100M	ELECTRO 10UF 50WV		
C41			CC73FCH1H470J	CHIP C 47PF J		
C42			CC73FCH1H270J	CHIP C 27PF J		

L : Scandinavia K : USA P : Canada R : Mexico C : China I : Malaysia

Y : PX(Far East,Hawaii) T : England E : Europe G : Germany V : China(Shanghai)

Y : AAFES(Europe) X : Australia Q : Russia H : Korea M : Other Areas Δ indicates safety critical components .

* New Parts

Parts without **Parts No.** are not supplied.
Les articles non mentionnés dans le **Parts No.** ne sont pas fournis.
Teile ohne **Parts No.** werden nicht geliefert.

7

Ref. No	Add-ress	New Parts	Parts No.	Description	Desti-nation	Re-marks
C43			CC73FCH1H220J	CHIP C 22PF	J	
C44			CC73FCH1H471J	CHIP C 470PF	J	
C45			CC73FCH1H220J	CHIP C 22PF	J	
C46			CE04KW1H100M	ELECTRO 10UF	50WV	
C47			CK73FB1H102K	CHIP C 1000PF	K	
C48			CE04KW1C470M	ELECTRO 47UF	16WV	
C49			CE04KW1H2R2M	ELECTRO 2.2UF	50WV	
C50			CC73FCH1H101J	CHIP C 100PF	J	
C51			CC73FCH1H471J	CHIP C 470PF	J	
C52			CC73FCH1H101J	CHIP C 100PF	J	
C70 ,71			CK73FB1H822K	CHIP C 8200PF	K	E1E2
C72			CE04KW1H010M	ELECTRO 1.0UF	50WV	
C73			CE04KW1C470M	ELECTRO 47UF	16WV	
C74			CK73FB1H102K	CHIP C 1000PF	K	KP1K1
C74			CK73FB1H102K	CHIP C 1000PF	K	P2Y1M1
C74			CK73FB1H102K	CHIP C 1000PF	K	X1V
C74			CK73FB1H102K	CHIP C 1000PF	K	Y1M1V
C74			CK73FB1H102K	CHIP C 1000PF	K	E1E2
C75			CC73FCH1H030C	CHIP C 3.0PF	C	
C76			CC73FCH1H470J	CHIP C 47PF	J	
C77			CC73FCH1H101J	CHIP C 100PF	J	
C78			CK73FB1H223K	CHIP C 0.022UF	K	
C79 ,80			CK73FB1H102K	CHIP C 1000PF	K	KP1K1
C79 ,80			CK73FB1H102K	CHIP C 1000PF	K	P2
C79 ,80			CK73FB1H122K	CHIP C 1200PF	K	X1
C79 ,80			CK73FB1H152K	CHIP C 1500PF	K	Y1M1V
C79 ,80			CK73FB1H472K	CHIP C 4700PF	K	E1E2
C81			CK73FF1C105Z	CHIP C 1.0UF	Z	
C82			CK73FB1H103K	CHIP C 0.010UF	K	
C84 ,85			CK73FB1H332K	CHIP C 3300PF	K	
C88			CK73FB1H332K	CHIP C 3300PF	K	
C91			CK73FF1C105Z	CHIP C 1.0UF	Z	
C92 ,93			CK73FB1H102K	CHIP C 1000PF	K	KP1K1
C92 ,93			CK73FB1H102K	CHIP C 1000PF	K	P2Y1M1
C92 ,93			CK73FB1H102K	CHIP C 1000PF	K	X1V
C94			CK73FB1H561K	CHIP C 560PF	K	
CN1			E40-3259-05	PIN ASSY		
CN2			E40-4871-05	PIN ASSY		
J1			E70-0080-05	LOCK TERMINAL BOARD	E2V	
J1			E70-0080-05	LOCK TERMINAL BOARD	KP1E1	
J1			E70-0080-05	LOCK TERMINAL BOARD	Y1M1X1	
J1		*	E70-0141-05	LOCK TERMINAL BOARD	K1P2	
E1			F10-1108-14	SHIELDING PLATE	KP1K1	
E1			F10-1108-14	SHIELDING PLATE	P2Y1M1	
E1			F10-1108-14	SHIELDING PLATE	X1V	
E1			F10-1109-14	SHIELDING PLATE	E1E2	
CF1 ,2			L72-0531-05	CERAMIC FILTER	V	
CF1 ,2			L72-0531-05	CERAMIC FILTER	Y1M1X1	
CF1 ,2			L72-0536-05	CERAMIC FILTER	E1E2	
CF1 ,2			L72-0596-05	CERAMIC FILTER	KP1K1	
CF1 ,2			L72-0596-05	CERAMIC FILTER	P2	
L1			L39-1384-05	COMBINATION COIL		
L2			L40-1091-82	SMALL FIXED INDUCTOR(1.0UH)		E1E2
L3			L30-0911-05	AM IFT		
L4			L30-0950-05	FM IFT		
L5			L30-0951-05	FM IFT		

L : Scandinavia K : USA P : Canada R : Mexico C : China I : Malaysia
Y : PX(Far East,Hawaii) T : England E : Europe G : Germany V : China(Shanghai)
Y : AAFES(Europe) X : Australia Q : Russia H : Korea M : Other Areas Δ indicates safety critical components .

* New Parts

Parts without **Parts No.** are not supplied.
Les articles non mentionnés dans le **Parts No.** ne sont pas fournis.
Teile ohne **Parts No.** werden nicht geliefert.

8

Ref. No	Add-ress	New Parts	Parts No.	Description	Desti-nation	Re-marks
L6 ,7			L79-1239-05	LC FILTER		E1E2
X1			L77-2187-05	CRYSTAL RESONATOR(7.2MHZ)		
R1			RK73FB2A101J	CHIP R 100	J	1/10W
R4			RK73FB2A681J	CHIP R 680	J	1/10W
R5			RK73FB2A332J	CHIP R 3.3K	J	1/10W
R6			RK73FB2A221J	CHIP R 220	J	1/10W
R7			RK73FB2A821J	CHIP R 820	J	1/10W
R8			RK73FB2A100J	CHIP R 10	J	1/10W
R8			RK73FB2A330J	CHIP R 33	J	1/10W
R8			RK73FB2A330J	CHIP R 33	J	1/10W
R8			RK73FB2A330J	CHIP R 33	J	1/10W
R9			RK73FB2A391J	CHIP R 390	J	1/10W
R10			RK73FB2A102J	CHIP R 1.0K	J	1/10W
R11			RK73FB2A220J	CHIP R 22	J	1/10W
R11			RK73FB2A330J	CHIP R 33	J	1/10W
R11			RK73FB2A330J	CHIP R 33	J	1/10W
R11			RK73FB2A330J	CHIP R 33	J	1/10W
R12			RK73FB2A101J	CHIP R 100	J	1/10W
R14			RK73FB2A101J	CHIP R 100	J	1/10W
R15			RK73FB2A333J	CHIP R 33K	J	1/10W
R16			RK73FB2A220J	CHIP R 22	J	1/10W
R17			RK73FB2A362J	CHIP R 3.6K	J	1/10W
R18			RK73FB2A302J	CHIP R 3.0K	J	1/10W
R19			RK73FB2A822J	CHIP R 8.2K	J	1/10W
R20			RK73FB2A392J	CHIP R 3.9K	J	1/10W
R23			RK73FB2A153J	CHIP R 15K	J	1/10W
R23			RK73FB2A472J	CHIP R 4.7K	J	1/10W
R23			RK73FB2A472J	CHIP R 4.7K	J	1/10W
R23			RK73FB2A682J	CHIP R 6.8K	J	1/10W
R25			RK73FB2A183J	CHIP R 18K	J	1/10W
R25			RK73FB2A183J	CHIP R 18K	J	1/10W
R25			RK73FB2A183J	CHIP R 18K	J	1/10W
R25			RK73FB2A273J	CHIP R 27K	J	1/10W
R27 ,28			RK73FB2A432J	CHIP R 4.3K	J	1/10W
R27 ,28			RK73FB2A682J	CHIP R 6.8K	J	1/10W
R27 ,28			RK73FB2A682J	CHIP R 6.8K	J	1/10W
R27 ,28			RK73FB2A682J	CHIP R 6.8K	J	1/10W
R29			RK73FB2A102J	CHIP R 1.0K	J	1/10W
R30			RK73FB2A561J	CHIP R 560	J	1/10W
R31			RK73FB2A473J	CHIP R 47K	J	1/10W
R33 ,34			RK73FB2A102J	CHIP R 1.0K	J	1/10W
R35			RK73FB2A101J	CHIP R 100	J	1/10W
R36			RK73FB2A102J	CHIP R 1.0K	J	1/10W
R37			RK73FB2A392J	CHIP R 3.9K	J	1/10W
R38			RK73FB2A102J	CHIP R 1.0K	J	1/10W
R39			RK73FB2A103J	CHIP R 10K	J	1/10W
R42			RK73FB2A103J	CHIP R 10K	J	1/10W
R43			RK73FB2A221J	CHIP R 220	J	1/10W
R44			RD14NB2E271J	RD 270	J	1/4W
R45			RK73EB2B332J	CHIP R 3.3K	J	1/8W
R46			RK73FB2A332J	CHIP R 3.3K	J	1/10W
R47			RK73EB2B332J	CHIP R 3.3K	J	1/8W
R48			RK73FB2A102J	CHIP R 1.0K	J	1/10W
R49			RK73FB2A103J	CHIP R 10K	J	1/10W

L : Scandinavia K : USA P : Canada R : Mexico C : China I : Malaysia
Y : PX(Far East,Hawaii) T : England E : Europe G : Germany V : China(Shanghai)
Y : AAFES(Europe) X : Australia Q : Russia H : Korea M : Other Areas Δ indicates safety critical components .

PARTS LIST

KRF-X7775D/X7775D-S/VR-5080/5090

* New Parts
Parts without **Parts No.** are not supplied.
Les articles non mentionnés dans le **Parts No.** ne sont pas fournis.
Teile ohne **Parts No.** werden nicht geliefert.

9

Ref. No	Add-ress	New Parts	Parts No.	Description	Desti-nation	Re-marks
R50			RD14NB2E471J	RD 470 J 1/4W		
R51			RK73FB2A562J	CHIP R 5.6K J 1/10W		
R52			RK73FB2A101J	CHIP R 100 J 1/10W		
R53			RK73FB2A222J	CHIP R 2.2K J 1/10W		
R54			RK73FB2A102J	CHIP R 1.0K J 1/10W		
R55			RK73FB2A333J	CHIP R 33K J 1/10W		
R56 .57			RK73FB2A102J	CHIP R 1.0K J 1/10W		
R58			RK73FB2A123J	CHIP R 12K J 1/10W		
R59			RK73FB2A122J	CHIP R 1.2K J 1/10W		
R72 .73			RK73FB2A333J	CHIP R 33K J 1/10W	KP1K1	
R72 .73			RK73FB2A333J	CHIP R 33K J 1/10W	P2Y1M1	
R72 .73			RK73FB2A392J	CHIP R 3.9K J 1/10W	X1V	
R74			RK73FB2A473J	CHIP R 47K J 1/10W	E1E2	
R75			RK73FB2A822J	CHIP R 8.2K J 1/10W		
R76			RK73FB2A182J	CHIP R 1.8K J 1/10W		
R78			RK73FB2A821J	CHIP R 820 J 1/10W		
R79			RK73FB2A332J	CHIP R 3.3K J 1/10W		
R80			RK73FB2A223J	CHIP R 22K J 1/10W	E1E2	
R81			RS14KB3A151J	FL-PROOF RS 150 J 1W		
R82			RK73FB2A272J	CHIP R 2.7K J 1/10W		
R83			RK73FB2A102J	CHIP R 1.0K J 1/10W		
R84			RK73EB2B332J	CHIP R 3.3K J 1/8W		
R85 .87			RK73FB2A333J	CHIP R 33K J 1/10W		
R88			RK73FB2A563J	CHIP R 56K J 1/10W		
R89			RK73FB2A333J	CHIP R 33K J 1/10W		
R90			RK73FB2A681J	CHIP R 680 J 1/10W		
VR1			R32-0037-05	SEMI FIXED VARIABLE RESISTOR		
W51 .52			R92-0670-05	CHIP R 0 OHM		
W54 .55			R92-0670-05	CHIP R 0 OHM		
W56			R92-0670-05	CHIP R 0 OHM	Y1M1V	
W59 .60			R92-0670-05	CHIP R 0 OHM		
W62			R92-0670-05	CHIP R 0 OHM		
W80			R92-0679-05	CHIP R 0 OHM		
W82 .85			R92-0679-05	CHIP R 0 OHM	KP1K1	
W82 .85			R92-0679-05	CHIP R 0 OHM	P2Y1M1	
W82 .85			R92-0679-05	CHIP R 0 OHM	X1V	
W84 .85			R92-0679-05	CHIP R 0 OHM	E1E2	
S1			S62-0034-05	SLIDE SWITCH	Y1M1V	
D1			DA204U	DIODE		
D1			MA143A	DIODE		
D1			1SS302	DIODE		
D3			MTZJ8.2(B)	ZENER DIODE		
D3			RD8.2ES(B2)	ZENER DIODE		
D4			MTZJ5.1(B)	ZENER DIODE		
D4			RD5.1ES(B2)	ZENER DIODE		
D5			MTZJ2.7(B)	ZENER DIODE		
D5			RD2.7ES(B2)	ZENER DIODE		
D8			MA111	DIODE		
D9			MTZJ3.3(B)	ZENER DIODE		
D9			RD3.3ES(B2)	ZENER DIODE		
D11			MA111	DIODE	E1E2	
D13			MA111	DIODE		
IC1			LA1837	ANALOGUE IC		

L : Scandinavia K : USA P : Canada R : Mexico C : China I : Malaysia
Y : PX(Far East,Hawaii) T : England E : Europe G : Germany V : China(Shanghai)
Y : AAFES(Europe) X : Australia Q : Russia H : Korea M : Other Areas Δ indicates safety critical components .

* New Parts
Parts without **Parts No.** are not supplied.
Les articles non mentionnés dans le **Parts No.** ne sont pas fournis.
Teile ohne **Parts No.** werden nicht geliefert.

10

Ref. No	Add-ress	New Parts	Parts No.	Description	Desti-nation	Re-marks
IC2			LC72131	MOS-IC		
Q1			2SC4081(R,S)	TRANSISTOR		
Q1			2SC4116(Y,GR)	TRANSISTOR		
Q2			2SA1576A(R,S)	TRANSISTOR		
Q2			2SA1586(Y,GR)	TRANSISTOR		
Q3 .4			2SC4081(R,S)	TRANSISTOR	Y1M1V	
Q3 .4			2SC4116(Y,GR)	TRANSISTOR	Y1M1V	
Q6 .7			2SC4081(R,S)	TRANSISTOR	E1E2	
Q6 .7			2SC4116(Y,GR)	TRANSISTOR	E1E2	
Q10 .11			2SD1757K	TRANSISTOR		
Q12			2SA1576A(R,S)	TRANSISTOR		
Q12			2SA1586(Y,GR)	TRANSISTOR		
Q14			2SA1576A(R,S)	TRANSISTOR		
Q14			2SA1586(Y,GR)	TRANSISTOR		
A1			W02-2584-05	FM FRONT-END ASSY	E1E2	
A1			W02-2622-05	FM FRONT-END ASSY	KP1K1	
A1			W02-2622-05	FM FRONT-END ASSY	P2Y1M1	
A1			W02-2622-05	FM FRONT-END ASSY	X1V	
POWER AMPLIFIER UNIT (X07-334/335X-XX)						
C1 -4			CE04KW1H3R3M	ELECTRO 3.3UF	50WV	
C5 .6			CC45FSL1H680J	CERAMIC 68PF	J	
C11 .12			CK45FB1H222K	CERAMIC 2200PF	K	
C13 .14			CC45FCH1H050C	CERAMIC 5.0PF	C	
C15 .16			CC45FSL1H101J	CERAMIC 100PF	J	
C17 .18			CE04KW1H100M	ELECTRO 10UF	50WV	
C19 .20			CK45FF1H103Z	CERAMIC 0.010UF	Z	
C21 .22			CC45FSL1H151J	CERAMIC 150PF	J	
C23 .24			CC45FSL2H470J	CERAMIC 47PF	J	
C25 .26			CC45FSL1H070D	CERAMIC 7.0PF	D	
C27 .28			CE04KW1A221M	ELECTRO 220UF	10WV	
C51 .54			CE04KW1H3R3M	ELECTRO 3.3UF	50WV	
C55 .56			CC45FSL1H680J	CERAMIC 68PF	J	
C61 .62			CK45FB1H222K	CERAMIC 2200PF	K	
C63 .64			CC45FCH1H050C	CERAMIC 5.0PF	C	
C65 .66			CC45FSL1H101J	CERAMIC 100PF	J	
C67 .68			CE04KW1H100M	ELECTRO 10UF	50WV	
C69 .70			CK45FF1H103Z	CERAMIC 0.010UF	Z	
C71 .72			CC45FSL1H151J	CERAMIC 150PF	J	
C73 .74			CC45FSL2H470J	CERAMIC 47PF	J	
C75 .76			CC45FSL1H070D	CERAMIC 7.0PF	D	
C77 .78			CE04KW1A221M	ELECTRO 220UF	10WV	
C101 .102			CE04KW1H3R3M	ELECTRO 3.3UF	50WV	
C103			CC45FSL1H680J	CERAMIC 68PF	J	
C106			CK45FB1H222K	CERAMIC 2200PF	K	
C107			CC45FCH1H050C	CERAMIC 5.0PF	C	
C108			CC45FSL1H101J	CERAMIC 100PF	J	
C109			CE04KW1A221M	ELECTRO 220UF	10WV	
C110			CK45FF1H103Z	CERAMIC 0.010UF	Z	
C111			CE04KW1H100M	ELECTRO 10UF	50WV	
C112			CC45FSL1H151J	CERAMIC 150PF	J	
C113			CC45FSL2H470J	CERAMIC 47PF	J	
C114			CC45FSL1H070D	CERAMIC 7.0PF	D	
C115			CE04KW1H220M	ELECTRO 22UF	50WV	
C116			CE04KW1E470M	ELECTRO 47UF	25WV	

L : Scandinavia K : USA P : Canada R : Mexico C : China I : Malaysia
Y : PX(Far East,Hawaii) T : England E : Europe G : Germany V : China(Shanghai)
Y : AAFES(Europe) X : Australia Q : Russia H : Korea M : Other Areas Δ indicates safety critical components .

* New Parts

Parts without **Parts No.** are not supplied.
Les articles non mentionnés dans le **Parts No.** ne sont pas fournis.
Teile ohne **Parts No.** werden nicht geliefert.

11

Ref. No	Address	New Parts	Parts No.	Description	Destination	Remarks
C117			CE04KW1H220M	ELECTRO 22UF 50WV		
C118			CC45FSL1H101J	CERAMIC 100PF J		
C119			CE04KW1E470M	ELECTRO 47UF 25WV		
C201-205			CK45FF1H103Z	CERAMIC 0.010UF Z		
C251-254			CF92FV1H224J	MF-C 0.22UF J	E1Y1M1	
C251-254			CF92FV1H224J	MF-C 0.22UF J	X1E2V	
C255,256			CF92FV1H104J	MF-C 0.10UF J	KP1K1	
C255,256			CF92FV1H104J	MF-C 0.10UF J	P2	
C257,258			CQ93FMG1H272J	MYLAR 2700PF J		
C259-262			CF92FV1H224J	MF-C 0.22UF J	E1Y1M1	
C259-262			CF92FV1H224J	MF-C 0.22UF J	X1E2V	
C263,264			CF92FV1H104J	MF-C 0.10UF J	KP1K1	
C263,264			CF92FV1H104J	MF-C 0.10UF J	P2	
C265,266			CQ93FMG1H393J	MYLAR 0.039UF J		
C267,268			CK45FB1H102K	CERAMIC 1000PF K		
C269,270			CF92FV1H224J	MF-C 0.22UF J	E1Y1M1	
C269,270			CF92FV1H224J	MF-C 0.22UF J	X1E2V	
C271			CF92FV1H104J	MF-C 0.10UF J	KP1K1	
C271			CF92FV1H104J	MF-C 0.10UF J	P2	
C301			CE04KW1A101M	ELECTRO 100UF 10WV		
C302			CE04KW1H4R7M	ELECTRO 4.7UF 50WV		
C303			CE04KW1H220M	ELECTRO 22UF 50WV		
C304			CE04KW1H470M	ELECTRO 47UF 50WV		
C305			CE04KW1E470M	ELECTRO 47UF 25WV		
C306,307			GE04KW2A100M	ELECTRO 10UF 100WV		
C308			CE04KW2A470M	ELECTRO 47UF 100WV		
C309,310			CE04KW2A220M	ELECTRO 22UF 100WV		
C351,352			CE04KW2A100M	ELECTRO 10UF 100WV		
C401,402			C90-3868-05	ELECTRO 8200UF 73WV		
C403			C91-1422-05	MP 0.10UF 250WV		
C404			CK45FE2H103P	CERAMIC 0.010UF P	KP1K1	
C404			CK45FE2H103P	CERAMIC 0.010UF P	P2	
C405,406			CK45FE2H103P	CERAMIC 0.010UF P		
C451			CQ93FMG1H473J	MYLAR 0.047UF J		
C452			GE04KW1E102M	ELECTRO 1000UF 25WV		
C453			C91-1488-05	MF 6800PF 250VAC		
C454			C91-1488-05	MF 6800PF 250VAC	Y1M1	
C455		*	C91-1627-05	POLYESTE 0.1UF 250VAC		
C456			CK45FF1H103Z	CERAMIC 0.010UF Z		
C567-571			CC45FSL1H221J	CERAMIC 220PF J		
CN1			E40-4879-05	PIN ASSY		
CN3			E40-8251-05	FLAT CABLE CONNECTOR		
CN4			E40-8255-05	FLAT CABLE CONNECTOR		
CN5			E40-4294-05	FLAT CABLE CONNECTOR		
CN6			E40-3247-05	PIN ASSY		
CN7			E40-3246-05	PIN ASSY		
CN8			E40-3247-05	PIN ASSY		
CN10			E40-4245-05	PIN ASSY		
CN11			E40-4245-05	PIN ASSY		
CN11			E40-4245-05	PIN ASSY	E2V	
CN12			E40-4281-05	PIN ASSY	KP1K1	
J1		*	E70-0131-05	SCREW TERMINAL BOARD	P2E1X1	
J2			E03-0148-05	AC OUTLET	Y1M1	
J2			E03-0148-05	AC OUTLET	KP1K1	
J2			E03-0148-05	AC OUTLET	P2Y1	

L : Scandinavia K : USA P : Canada R : Mexico C : China I : Malaysia
Y : PX(Far East,Hawaii) T : England E : Europe G : Germany V : China(Shanghai)
Y : AAFES(Europe) X : Australia Q : Russia H : Korea M : Other Areas Δ indicates safety critical components .

* New Parts

Parts without **Parts No.** are not supplied.
Les articles non mentionnés dans le **Parts No.** ne sont pas fournis.
Teile ohne **Parts No.** werden nicht geliefert.

12

Ref. No	Address	New Parts	Parts No.	Description	Destination	Remarks
J2			E03-0149-05	AC OUTLET	E1M1E2	
J2			E03-0325-05	AC OUTLET	X1	
J2			E03-0361-05	AC OUTLET	V	
F1			F05-3121-05	FUSE (SEMKO) (250V T3.15AL)	Y1M1	
F1			F05-4025-05	FUSE (SEMKO) (250V T4A L)	E1X1E2	
F1			F50-0078-05	FUSE(5X20)	KP1K1	
F1			F50-0078-05	FUSE(5X20)	P2	
F1			F50-0112-05	FUSE(5X20)	V	
F2			F05-3121-05	FUSE (SEMKO) (250V T3.15AL)	Y1M1	
F3			F05-2525-05	FUSE (SEMKO) (250V T2.5AL)	E1E2	
FAN	1B		F09-0139-05	FAN		
CN31,32			J13-0075-05	FUSE CLIP		
CN33,34			J13-0075-05	FUSE CLIP	Y1M1	
CN35,36			J13-0075-05	FUSE CLIP	E1E2	
E2			J11-0808-05	WIRE CLAMPER		
L1 -5			L39-0085-05	PHASE COMPENSATION COIL		
T1		*	L07-2936-05	POWER TRANSFORMER	E1X1E2	
T1		*	L07-2936-05	POWER TRANSFORMER	V	
T1		*	L07-2937-05	POWER TRANSFORMER	Y1M1	
T1		*	L07-2939-05	POWER TRANSFORMER	KP1K1	
T1		*	L07-2939-05	POWER TRANSFORMER	P2	
R23 ,24			RD14NB2E101J	RD 100 J 1/4W		
R29 -32			RD14NB2E221J	RD 220 J 1/4W		
R73 ,74			RD14NB2E101J	RD 100 J 1/4W		
R79 -82			RD14NB2E221J	RD 220 J 1/4W		
R112			RD14NB2E101J	RD 100 J 1/4W		
R115,116			RD14NB2E221J	RD 220 J 1/4W		
R155			RD14NB2E220J	RD 22 J 1/4W		
R201-204			RD14NB2E470J	RD 47 J 1/4W		
R205,206			RD14NB2E151J	RD 150 J 1/4W		
R207-210			RD14NB2E101J	RD 100 J 1/4W		
R213-216			RD14NB2E332J	RD 3.3K J 1/4W		
R229,230			RD14NB2E220J	RD 22 J 1/4W		
R251-254			RD14NB2E470J	RD 47 J 1/4W		
R255,256			RD14NB2E151J	RD 150 J 1/4W		
R257-260			RD14NB2E101J	RD 100 J 1/4W		
R263-266			RD14NB2E332J	RD 3.3K J 1/4W		
R279,280			RD14NB2E220J	RD 22 J 1/4W		
R301,302			RD14NB2E470J	RD 47 J 1/4W		
R303			RD14NB2E151J	RD 150 J 1/4W		
R304,305			RD14NB2E101J	RD 100 J 1/4W		
R307,308			RD14NB2E332J	RD 3.3K J 1/4W		
R315			RD14NB2E220J	RD 22 J 1/4W		
R351-355			RS14KB3D2R7J	FL-PROOF RS 2.7 J 2W		
R356-359			RD14NB2E271J	RD 270 J 1/4W		
R360,361			RS14KB3D471J	FL-PROOF RS 470 J 2W		
R362			RD14NB2E271J	RD 270 J 1/4W		
R394			RD14NB2E100J	RD 10 J 1/4W		
R395			RD14NB2E682J	RD 6.8K J 1/4W		
R398			RD14NB2E272J	RD 2.7K J 1/4W		
R451,452			RD14NB2E560J	RD 56 J 1/4W		
R502			R92-1844-05	CARBON 3.3M J 1/2W	KP1K1	
R502			R92-1844-05	CARBON 3.3M J 1/2W	P2	

L : Scandinavia K : USA P : Canada R : Mexico C : China I : Malaysia
Y : PX(Far East,Hawaii) T : England E : Europe G : Germany V : China(Shanghai)
Y : AAFES(Europe) X : Australia Q : Russia H : Korea M : Other Areas Δ indicates safety critical components .

PARTS LIST

KRF-X7775D/X7775D-S/VR-5080/5090

* New Parts
Parts without **Parts No.** are not supplied.
Les articles non mentionnés dans le **Parts No.** ne sont pas fournis.
Teile ohne **Parts No.** werden nicht geliefert.

13

Ref. No	Add-ress	New Parts	Parts No.	Description	Desti-nation	Re-marks
△ R506 R510 VR1 -5			RD14NB2E1R0J RS14KB3D182J R32-0030-05	RD 1 J 1/4W FL-PROOF RS 1.8K J 2W SEMI FIXED VARIABLE RESISTOR		
K1 -5 K6 △ S1			S76-0076-05 S76-0106-05 S31-3010-05	MAGNETIC RELAY MAGNETIC RELAY SLIDE SWITCH	Y1M1	
D1 -4 D1 -4 D11 -14 D11 -14 D21 ,22			HSS104A 1SS133 HSS104A 1SS133 HSS104A	DIODE DIODE DIODE DIODE DIODE		
D21 ,22 D51 ,52 D53 -62 D53 -62 D71 ,72			1SS133 1SS244 HSS104A 1SS133 1SS244	DIODE DIODE DIODE DIODE DIODE		
D73 -82 D73 -82 D91 D92 -96 D92 -96			HSS104A 1SS133 1SS244 HSS104A 1SS133	DIODE DIODE DIODE DIODE DIODE		
△ D100 △ D101,102 D103 D103 D104			RBV-1506LFA S5688B MTZJ13(B) RD13ES(B2) MTZJ15(B)	DIODE DIODE ZENER DIODE ZENER DIODE ZENER DIODE		
D104 D105,106 D105,106 D107,108 D107,108			RD15ES(B2) MTZJ4.7(B) RD4.7ES(B2) HSS104A 1SS133	ZENER DIODE ZENER DIODE ZENER DIODE DIODE DIODE		
D109 D109 D111-115 D111-115 D121,122			MTZJ5.1(B) RD5.1ES(B2) HSS104A 1SS133 MTZJ18(B)	ZENER DIODE ZENER DIODE DIODE DIODE ZENER DIODE		
D121,122 D123,124 D123,124 D251 D251			RD18ES(B2) MTZJ20(B) RD20ES(B2) MTZJ5.1(B) RD5.1ES(B2)	ZENER DIODE ZENER DIODE ZENER DIODE ZENER DIODE ZENER DIODE		
D252,253 D252,253 D502 D502 △ D503-508			HSS104A 1SS133 HSS104A 1SS133 S5688B	DIODE DIODE DIODE DIODE DIODE		
△ D509 △ D509 △ D510 D511-513 D511-513			HSS104A 1SS133 S5688B HSS104A 1SS133	DIODE DIODE DIODE DIODE DIODE		
D514 D514 Q1 ,2			MTZJ4.7(B) RD4.7ES(B2) 2SC2878(B)	ZENER DIODE ZENER DIODE TRANSISTOR		

L : Scandinavia K : USA P : Canada R : Mexico C : China I : Malaysia
Y : PX(Far East,Hawaii) T : England E : Europe G : Germany V : China(Shanghai)
Y : AAFES(Europe) X : Australia Q : Russia H : Korea M : Other Areas △ indicates safety critical components .

* New Parts
Parts without **Parts No.** are not supplied.
Les articles non mentionnés dans le **Parts No.** ne sont pas fournis.
Teile ohne **Parts No.** werden nicht geliefert.

14

Ref. No	Add-ress	New Parts	Parts No.	Description	Desti-nation	Re-marks
Q3 -6 Q7 ,8 Q9 -12 Q13 ,14 Q13 ,14			2SA992(F,E) 2SA1123(R,S) 2SC2631(R,S) 2SA1048(Y,GR) 2SA933AS(Q,R)	TRANSISTOR TRANSISTOR TRANSISTOR TRANSISTOR TRANSISTOR		
Q51 ,52 Q53 -56 Q57 ,58 Q59 -62 Q63 ,64			2SC2878(B) 2SA992(F,E) 2SA1123(R,S) 2SC2631(R,S) 2SA1048(Y,GR)	TRANSISTOR TRANSISTOR TRANSISTOR TRANSISTOR TRANSISTOR		
Q63 ,64 Q101 Q102,103 Q104,105 Q106			2SA933AS(Q,R) 2SC2878(B) 2SA992(F,E) 2SC2631(R,S) 2SA1123(R,S)	TRANSISTOR TRANSISTOR TRANSISTOR TRANSISTOR TRANSISTOR		
Q107 Q107 Q108 △ Q108 Q109			2SA1048(Y,GR) 2SA933AS(Q,R) 2SC1740S(Q,R) 2SC2458(Y,GR) DTC124ESA	TRANSISTOR TRANSISTOR TRANSISTOR TRANSISTOR DIGITAL TRANSISTOR		
Q109 △ Q201,202 △ Q203,204 Q205,206 Q207,208		*	UN4212 TRAIT8N*5 TRAIT8P*5 2SC1845(F,E) 2SA992(F,E)	DIGITAL TRANSISTOR TRANSISTOR TRANSISTOR TRANSISTOR TRANSISTOR		
△ Q251,252 △ Q253,254 Q255,256 Q257,258 △ Q301		*	TRAIT8N*5 TRAIT8P*5 2SC1845(F,E) 2SA992(F,E) TRAIT8N*5	TRANSISTOR TRANSISTOR TRANSISTOR TRANSISTOR TRANSISTOR		
△ Q302 Q303 Q304 Q351-354 Q351-354		*	TRAIT8P*5 2SC1845(F,E) 2SA992(F,E) DTC113ZSA UN4219	TRANSISTOR TRANSISTOR TRANSISTOR DIGITAL TRANSISTOR DIGITAL TRANSISTOR		
Q381,382 Q383,384 Q401 Q401 Q402,403			2SC1845(F,E) 2SA992(F,E) DTC124ESA UN4212 DTC113ZSA	TRANSISTOR TRANSISTOR DIGITAL TRANSISTOR DIGITAL TRANSISTOR DIGITAL TRANSISTOR		
△ Q402,403 △ Q404 Q405,406 Q405,406 △ Q407			UN4219 2SD2012 2SC1740S(Q,R) 2SC2458(Y,GR) 2SA1110(R,S)	DIGITAL TRANSISTOR TRANSISTOR TRANSISTOR TRANSISTOR TRANSISTOR		
Q408 Q530 Q530			2SC2003(L,K) 2SA1048(Y,GR) 2SA933AS(Q,R)	TRANSISTOR TRANSISTOR TRANSISTOR		
SURROUND UNIT (X08-309/310X-XX)						
C1 C2 C4 C11 C12			CC73GCH1H470J CK73GB1H103K CC73GCH1H470J CC73GCH1H470J CK73GB1H103K	CHIP C CHIP C CHIP C CHIP C CHIP C	47PF 0.010UF 47PF 47PF 0.010UF	J K J J K

L : Scandinavia K : USA P : Canada R : Mexico C : China I : Malaysia
Y : PX(Far East,Hawaii) T : England E : Europe G : Germany V : China(Shanghai)
Y : AAFES(Europe) X : Australia Q : Russia H : Korea M : Other Areas △ indicates safety critical components .

* New Parts

Parts without **Parts No.** are not supplied.
Les articles non mentionnés dans le **Parts No.** ne sont pas fournis.
Teile ohne **Parts No.** werden nicht geliefert.

15

Ref. No	Add-ress	New Parts	Parts No.	Description	Desti-nation	Re-marks
C14			CC73GCH1H470J	CHIP C	47PF	J
C15			CC73GCH1H102J	CHIP C	1000PF	J
C21			CC73GCH1H470J	CHIP C	47PF	J
C22			CK73GB1H103K	CHIP C	0.010UF	K
C24			CC73GCH1H470J	CHIP C	47PF	J
C31			CC73GCH1H470J	CHIP C	47PF	J
C32			CK73GB1H103K	CHIP C	0.010UF	K
C34			CC73GCH1H470J	CHIP C	47PF	J
C35			CC73GCH1H102J	CHIP C	1000PF	J
C41			CC73GCH1H470J	CHIP C	47PF	J
C42			CK73GB1H103K	CHIP C	0.010UF	K
C44			CC73GCH1H470J	CHIP C	47PF	J
C51			CC73GCH1H470J	CHIP C	47PF	J
C52			CK73GB1H103K	CHIP C	0.010UF	K
C54			CC73GCH1H470J	CHIP C	47PF	J
C55			CC73GCH1H102J	CHIP C	1000PF	J
C61			CC73GCH1H470J	CHIP C	47PF	J
C62			CK73GB1H103K	CHIP C	0.010UF	K
C64			CC73GCH1H470J	CHIP C	47PF	J
C71			CC73GCH1H102J	CHIP C	1000PF	J
C72			CC73GCH1H220J	CHIP C	22PF	J
C73			CK73GF1E104Z	CHIP C	0.10UF	Z
C74			CC73GCH1H220J	CHIP C	22PF	J
C75			CC73GCH1H102J	CHIP C	1000PF	J
C76			CC73GCH1H270J	CHIP C	27PF	J
C101			CK73GF1E104Z	CHIP C	0.10UF	Z
C102			CC73GCH1H102J	CHIP C	1000PF	J
C103, 104			CC73GCH1H220J	CHIP C	22PF	J
C105			CK73GF1E104Z	CHIP C	0.10UF	Z
C107-109			CK73GF1E104Z	CHIP C	0.10UF	Z
C110			CK73GB1H103K	CHIP C	0.010UF	K
C111			CE04KW1H100M	ELECTRO	10UF	50WV
C112			CC73GCH1H470J	CHIP C	47PF	J
C113			CC73GCH1H150J	CHIP C	15PF	J
C114			CC73GCH1H470J	CHIP C	47PF	J
C116			CE04KW1A101M	ELECTRO	100UF	10WV
C201			CE04KW1H100M	ELECTRO	10UF	50WV
C202			CC73GCH1H102J	CHIP C	1000PF	J
C203			CE04KW1A101M	ELECTRO	100UF	10WV
C205			CE04KW1E470M	ELECTRO	47UF	25WV
C206			CC73GCH1H102J	CHIP C	1000PF	J
C207			CE04KW1H100M	ELECTRO	10UF	50WV
C208			CE04KW1E470M	ELECTRO	47UF	25WV
C212			CC73GCH1H470J	CHIP C	47PF	J
C213-216			CC73GCH1H471J	CHIP C	470PF	J
C221,222			CE04KW1H100M	ELECTRO	10UF	50WV
C223,224			CC73GCH1H101J	CHIP C	100PF	J
C225,226			CC73GCH1H151J	CHIP C	150PF	J
C227,228			CC73GCH1H101J	CHIP C	100PF	J
C229,230			CE04KW1E470M	ELECTRO	47UF	25WV
C231,232			CC73GCH1H220J	CHIP C	22PF	J
C233,234			CK73GB1H222K	CHIP C	2200PF	K
C235,236			CC73GCH1H101J	CHIP C	100PF	J
C301			CK73GF1E104Z	CHIP C	0.10UF	Z
C302			CE04KW1A101M	ELECTRO	100UF	10WV

L : Scandinavia K : USA P : Canada R : Mexico C : China I : Malaysia
Y : PX(Far East,Hawaii) T : England E : Europe G : Germany V : China(Shanghai)
Y : AAFES(Europe) X : Australia Q : Russia H : Korea M : Other Areas Δ indicates safety critical components .

* New Parts

Parts without **Parts No.** are not supplied.
Les articles non mentionnés dans le **Parts No.** ne sont pas fournis.
Teile ohne **Parts No.** werden nicht geliefert.

16

Ref. No	Add-ress	New Parts	Parts No.	Description	Desti-nation	Re-marks
C303			CC73GCH1H102J	CHIP C	1000PF	J
C304			CE04KW1H100M	ELECTRO	10UF	50WV
C305			CC73GCH1H101J	CHIP C	100PF	J
C306			CE04KW1H100M	ELECTRO	10UF	50WV
C307			CC73GCH1H101J	CHIP C	100PF	J
C311,312			CQ93FMG1H272J	MYLAR	2700PF	J
C313,314			CC73GCH1H220J	CHIP C	22PF	J
C315-320			CC73GCH1H101J	CHIP C	100PF	J
C321,322			CQ93FMG1H223J	MYLAR	0.022UF	J
C323,324			CC73GCH1H101J	CHIP C	100PF	J
C325,326			CQ93FMG1H102J	MYLAR	1000PF	J
C327,328			CQ93FMG1H472J	MYLAR	4700PF	J
C329,330			CC73GCH1H101J	CHIP C	100PF	J
C331,332			CC73GCH1H050C	CHIP C	5.0PF	C
C351			CK73GF1E104Z	CHIP C	0.10UF	Z
C352			CE04KW1A101M	ELECTRO	100UF	10WV
C353			CC73GCH1H102J	CHIP C	1000PF	J
C354			CE04KW1H100M	ELECTRO	10UF	50WV
C355			CC73GCH1H101J	CHIP C	100PF	J
C356			CE04KW1H100M	ELECTRO	10UF	50WV
C357			CC73GCH1H101J	CHIP C	100PF	J
C361,362			CQ93FMG1H272J	MYLAR	2700PF	J
C363,364			CC73GCH1H220J	CHIP C	22PF	J
C365-370			CC73GCH1H101J	CHIP C	100PF	J
C371,372			CQ93FMG1H223J	MYLAR	0.022UF	J
C373,374			CC73GCH1H101J	CHIP C	100PF	J
C375,376			CQ93FMG1H102J	MYLAR	1000PF	J
C377,378			CQ93FMG1H472J	MYLAR	4700PF	J
C379,380			CC73GCH1H101J	CHIP C	100PF	J
C381,382			CC73GCH1H050C	CHIP C	5.0PF	C
C401			CK73GF1E104Z	CHIP C	0.10UF	Z
C402			CE04KW1A101M	ELECTRO	100UF	10WV
C403			CC73GCH1H102J	CHIP C	1000PF	J
C404			CE04KW1H100M	ELECTRO	10UF	50WV
C405			CC73GCH1H101J	CHIP C	100PF	J
C406			CE04KW1H100M	ELECTRO	10UF	50WV
C407			CC73GCH1H101J	CHIP C	100PF	J
C411			CQ93FMG1H272J	MYLAR	2700PF	J
C412			CQ93FMG1H103J	MYLAR	0.010UF	J
C413,414			CC73GCH1H220J	CHIP C	22PF	J
C415-417			CC73GCH1H101J	CHIP C	100PF	J
C418			CK73GB1H272K	CHIP C	2700PF	K
C419,420			CC73GCH1H101J	CHIP C	100PF	J
C421,422			CQ93FMG1H223J	MYLAR	0.022UF	J
C423,424			CC73GCH1H101J	CHIP C	100PF	J
C425			CQ93FMG1H102J	MYLAR	1000PF	J
C426			CQ93FMG1H272J	MYLAR	2700PF	J
C427			CQ93FMG1H472J	MYLAR	4700PF	J
C428			CQ93FMG1H223J	MYLAR	0.022UF	J
C429,430			CC73GCH1H101J	CHIP C	100PF	J
C431,432			CC73GCH1H050C	CHIP C	5.0PF	C
C451			CK73GF1E104Z	CHIP C	0.10UF	Z
C452			CE04KW1A101M	ELECTRO	100UF	10WV
C453			CC73GCH1H102J	CHIP C	1000PF	J
C454			CE04KW1H100M	ELECTRO	10UF	50WV

L : Scandinavia K : USA P : Canada R : Mexico C : China I : Malaysia
Y : PX(Far East,Hawaii) T : England E : Europe G : Germany V : China(Shanghai)
Y : AAFES(Europe) X : Australia Q : Russia H : Korea M : Other Areas Δ indicates safety critical components .

PARTS LIST

KRF-X7775D/X7775D-S/VR-5080/5090

* New Parts
Parts without **Parts No.** are not supplied.
Les articles non mentionnés dans le **Parts No.** ne sont pas fournis.
Teile ohne **Parts No.** werden nicht geliefert.

17

Ref. No	Add-ress	New Parts	Parts No.	Description	Desti-nation	Re-marks
C455			CC73GCH1H101J	CHIP C 100PF J		
C456			CE04KW1H100M	ELECTRO 10UF 50WV		
C457			CC73GCH1H101J	CHIP C 100PF J		
C461,462			CQ93FMG1H272J	MYLAR 2700PF J		
C463,464			CC73GCH1H220J	CHIP C 22PF J		
C465-470			CC73GCH1H101J	CHIP C 100PF J		
C471,472			CQ93FMG1H223J	MYLAR 0.022UF J		
C473,474			CC73GCH1H101J	CHIP C 100PF J		
C475,476			CQ93FMG1H102J	MYLAR 1000PF J		
C477,478			CQ93FMG1H472J	MYLAR 4700PF J		
C479,480			CC73GCH1H101J	CHIP C 100PF J		
C481,482			CC73GCH1H050C	CHIP C 5.0PF C		
C601-605			CC73GCH1H102J	CHIP C 1000PF J		
C606,607			CC73GCH1H090D	CHIP C 9.0PF D		
C608-630			CC73GCH1H102J	CHIP C 1000PF J		
C631			CK73GB1H103K	CHIP C 0.010UF K		
C632-634			CC73GCH1H102J	CHIP C 1000PF J		
C701-706			CC73GCH1H102J	CHIP C 1000PF J		
C707			CK73GB1H103K	CHIP C 0.010UF K		
C801,802			CK73GB1H103K	CHIP C 0.010UF K		
C803			CE04KW1H100M	ELECTRO 10UF 50WV		
C804			CK73GB1H103K	CHIP C 0.010UF K		
C805			CC73GCH1H102J	CHIP C 1000PF J		
C806			CK73GB1H103K	CHIP C 0.010UF K		
C951			CE04KW1E470M	ELECTRO 47UF 25WV		
C954			CE04KW1E470M	ELECTRO 47UF 25WV		
C955			CE04DW1A102M	ELECTRO 1000UF 10WV		
C956			CK73GB1H103K	CHIP C 0.010UF K		
C958			CE04KW1A101M	ELECTRO 100UF 10WV		
C959			CE04KW1H100M	ELECTRO 10UF 50WV		
C960			CC73GCH1H102J	CHIP C 1000PF J		
C961			CK73GB1H103K	CHIP C 0.010UF K		
C963			CE04KW1A101M	ELECTRO 100UF 10WV		
C965			CE04KW1E470M	ELECTRO 47UF 25WV		
CN1 ,2			E40-9836-05	SOCKET FOR PIN ASSY		
CN3			E40-9832-05	SOCKET FOR PIN ASSY		
J1			E63-1128-05	PIN JACK	K1P2	
J2			E63-1129-05	PIN JACK	E2V	
J2			E63-1129-05	PIN JACK	KP1E1	
J2			E63-1129-05	PIN JACK	Y1M1X1	
J2			E63-1130-05	PIN JACK	K1P2	
J3 ,4			E63-1124-05	PIN JACK	K1P2	
L1 ,2			L40-4795-34	SMALL FIXED INDUCTOR(4.7UH)		
X1		*	L77-2337-05	CRYSTAL RESONATOR(12.288MHZ)		
X2		*	L77-2314-05	CRYSTAL RESONATOR(33MHZ)		
X3			L78-0604-05	RESONATOR (6.00MHZ)		
R1			RK73GB1J750J	CHIP R 75 J 1/16W		
R2			RK73GB1J751J	CHIP R 750 J 1/16W		
R3			RK73GB1J104J	CHIP R 100K J 1/16W		
R4			RK73GB1J184J	CHIP R 180K J 1/16W		
R5			RK73GB1J470J	CHIP R 47 J 1/16W		
R7			RK73GB1J151J	CHIP R 150 J 1/16W		
R11			RK73GB1J750J	CHIP R 75 J 1/16W		
R12			RK73GB1J751J	CHIP R 750 J 1/16W		

L : Scandinavia K : USA P : Canada R : Mexico C : China I : Malaysia
Y : PX(Far East,Hawaii) T : England E : Europe G : Germany V : China(Shanghai)
Y : AAFES(Europe) X : Australia Q : Russia H : Korea M : Other Areas Δ indicates safety critical components .

* New Parts
Parts without **Parts No.** are not supplied.
Les articles non mentionnés dans le **Parts No.** ne sont pas fournis.
Teile ohne **Parts No.** werden nicht geliefert.

18

Ref. No	Add-ress	New Parts	Parts No.	Description	Desti-nation	Re-marks
R13			RK73GB1J104J	CHIP R 100K J 1/16W		
R14			RK73GB1J184J	CHIP R 180K J 1/16W		
R15			RK73GB1J470J	CHIP R 47 J 1/16W		
R17			RK73GB1J151J	CHIP R 150 J 1/16W		
R18			RK73FB2A100J	CHIP R 10 J 1/10W		
R21			RK73GB1J750J	CHIP R 75 J 1/16W		
R22			RK73GB1J751J	CHIP R 750 J 1/16W		
R23			RK73GB1J104J	CHIP R 100K J 1/16W		
R24			RK73GB1J184J	CHIP R 180K J 1/16W		
R25			RK73GB1J470J	CHIP R 47 J 1/16W		
R27			RK73GB1J151J	CHIP R 150 J 1/16W		
R31			RK73GB1J750J	CHIP R 75 J 1/16W	K1P2	
R32			RK73GB1J751J	CHIP R 750 J 1/16W	K1P2	
R33			RK73GB1J104J	CHIP R 100K J 1/16W	K1P2	
R34			RK73GB1J184J	CHIP R 180K J 1/16W	K1P2	
R35			RK73GB1J470J	CHIP R 47 J 1/16W	K1P2	
R36			RK73GB1J103J	CHIP R 10K J 1/16W	E2V	
R36			RK73GB1J103J	CHIP R 10K J 1/16W	KP1E1	
R36			RK73GB1J103J	CHIP R 10K J 1/16W	Y1M1X1	
R37			RK73GB1J151J	CHIP R 150 J 1/16W	K1P2	
R41			RK73GB1J750J	CHIP R 75 J 1/16W	K1P2	
R42			RK73GB1J751J	CHIP R 750 J 1/16W	K1P2	
R43			RK73GB1J104J	CHIP R 100K J 1/16W	K1P2	
R44			RK73GB1J184J	CHIP R 180K J 1/16W	K1P2	
R45			RK73GB1J470J	CHIP R 47 J 1/16W	K1P2	
R46			RK73GB1J103J	CHIP R 10K J 1/16W	E2V	
R46			RK73GB1J103J	CHIP R 10K J 1/16W	KP1E1	
R46			RK73GB1J103J	CHIP R 10K J 1/16W	Y1M1X1	
R47			RK73GB1J151J	CHIP R 150 J 1/16W	K1P2	
R48			RK73FB2A100J	CHIP R 10 J 1/10W	K1P2	
R51			RK73GB1J750J	CHIP R 75 J 1/16W	K1P2	
R52			RK73GB1J751J	CHIP R 750 J 1/16W	K1P2	
R53			RK73GB1J104J	CHIP R 100K J 1/16W	K1P2	
R54			RK73GB1J184J	CHIP R 180K J 1/16W	K1P2	
R55			RK73GB1J470J	CHIP R 47 J 1/16W	K1P2	
R56			RK73GB1J103J	CHIP R 10K J 1/16W	E2V	
R56			RK73GB1J103J	CHIP R 10K J 1/16W	KP1E1	
R56			RK73GB1J103J	CHIP R 10K J 1/16W	Y1M1X1	
R57			RK73GB1J151J	CHIP R 150 J 1/16W	K1P2	
R58			RK73FB2A100J	CHIP R 10 J 1/10W	K1P2	
R61			RK73GB1J750J	CHIP R 75 J 1/16W	K1P2	
R62			RK73GB1J751J	CHIP R 750 J 1/16W	K1P2	
R63			RK73GB1J104J	CHIP R 100K J 1/16W	K1P2	
R64			RK73GB1J184J	CHIP R 180K J 1/16W	K1P2	
R65			RK73GB1J470J	CHIP R 47 J 1/16W	K1P2	
R66			RK73GB1J103J	CHIP R 10K J 1/16W	E2V	
R66			RK73GB1J103J	CHIP R 10K J 1/16W	KP1E1	
R66			RK73GB1J103J	CHIP R 10K J 1/16W	Y1M1X1	
R67			RK73GB1J151J	CHIP R 150 J 1/16W	K1P2	
R71			RK73FB2A100J	CHIP R 10 J 1/10W	K1P2	
R72			RK73GB1J100J	CHIP R 10 J 1/16W	K1P2	
R73			RK73GB1J221J	CHIP R 220 J 1/16W	K1P2	
R74 ,75			RK73GB1J750J	CHIP R 75 J 1/16W	K1P2	
R76			RK73FB2A100J	CHIP R 10 J 1/10W		
R77			RK73GB1J101J	CHIP R 100 J 1/16W		

L : Scandinavia K : USA P : Canada R : Mexico C : China I : Malaysia
Y : PX(Far East,Hawaii) T : England E : Europe G : Germany V : China(Shanghai)
Y : AAFES(Europe) X : Australia Q : Russia H : Korea M : Other Areas Δ indicates safety critical components .

* New Parts

Parts without **Parts No.** are not supplied.
Les articles non mentionnés dans le **Parts No.** ne sont pas fournis.
Teile ohne **Parts No.** werden nicht geliefert.

19

Ref. No	Address	New Parts	Parts No.	Description	Quantity	Unit	Weight	Destination	Remarks
R79			RK73GB1J102J	CHIP R	1.0K	J	1/16W		
R80			RK73GB1J103J	CHIP R	10K	J	1/16W		
R101			RK73FB2A100J	CHIP R	10	J	1/10W		
R102			RK73GB1J101J	CHIP R	100	J	1/16W		
R103,104			RK73GB1J105J	CHIP R	1.0M	J	1/16W		
R105			RK73GB1J152J	CHIP R	1.5K	J	1/16W		
R106			RK73GB1J102J	CHIP R	1.0K	J	1/16W		
R107			RK73GB1J183J	CHIP R	18K	J	1/16W		
R108			RK73FB2A1R0J	CHIP R	1	J	1/10W		
R110			RK73GB1J103J	CHIP R	10K	J	1/16W		
R111			RK73GB1J102J	CHIP R	1.0K	J	1/16W		
R112			RK73GB1J103J	CHIP R	10K	J	1/16W		
R113-117			RK73GB1J102J	CHIP R	1.0K	J	1/16W		
R118			RK73GB1J471J	CHIP R	470	J	1/16W		
R119			RK73GB1J472J	CHIP R	4.7K	J	1/16W		
R120			RK73GB1J103J	CHIP R	10K	J	1/16W		
R121			RK73GB1J102J	CHIP R	1.0K	J	1/16W		
R122			RK73GB1J151J	CHIP R	150	J	1/16W		
R123			RK73GB1J101J	CHIP R	100	J	1/16W		
R124			RK73GB1J151J	CHIP R	150	J	1/16W		
R125			RK73GB1J101J	CHIP R	100	J	1/16W		
R126			RK73FB2A2R2J	CHIP R	2.2	J	1/10W		
R127			RK73GB1J103J	CHIP R	10K	J	1/16W		
R201			RK73FB2A1R0J	CHIP R	1	J	1/10W		
R202			RK73GB1J102J	CHIP R	1.0K	J	1/16W		
R203-206			RK73GB1J473J	CHIP R	47K	J	1/16W		
R207			RK73FB2A1R0J	CHIP R	1	J	1/10W		
R208,209			RK73GB1J103J	CHIP R	10K	J	1/16W		
R210			RK73GB1J101J	CHIP R	100	J	1/16W		
R211			RK73GB1J221J	CHIP R	220	J	1/16W		
R221,222			RK73GB1J273J	CHIP R	27K	J	1/16W		
R223,224			RK73GB1J123J	CHIP R	12K	J	1/16W		
R225,226			RK73GB1J561J	CHIP R	560	J	1/16W		
R227-230			RK73GB1J472J	CHIP R	4.7K	J	1/16W		
R233-236			RK73GB1J471J	CHIP R	470	J	1/16W		
R301			RK73FB2A100J	CHIP R	10	J	1/10W		
R302-304			RK73GB1J102J	CHIP R	1.0K	J	1/16W		
R305			RK73FB2A100J	CHIP R	10	J	1/10W		
R306			RK73FB2A1R0J	CHIP R	1	J	1/10W		
R307			RK73GB1J1R0J	CHIP R	1	J	1/16W		
R311-314			RK73GB1J182J	CHIP R	1.8K	J	1/16W		
R315-318			RK73GB1J102J	CHIP R	1.0K	J	1/16W		
R319-322			RK73GB1J472J	CHIP R	4.7K	J	1/16W		
R323,324			RK73GB1J100J	CHIP R	10	J	1/16W		
R325-328			RK73GB1J681J	CHIP R	680	J	1/16W		
R329,330			RK73GB1J471J	CHIP R	470	J	1/16W		
R331,332			RK73GB1J121J	CHIP R	120	J	1/16W		
R333,334			RK73GB1J100J	CHIP R	10	J	1/16W		
R335,336			RK73GB1J1R0J	CHIP R	1	J	1/16W		
R351			RK73FB2A100J	CHIP R	10	J	1/10W		
R352-354			RK73GB1J102J	CHIP R	1.0K	J	1/16W		
R355			RK73FB2A100J	CHIP R	10	J	1/10W		
R356			RK73FB2A1R0J	CHIP R	1	J	1/10W		
R357			RK73GB1J1R0J	CHIP R	1	J	1/16W		
R361-368			RK73GB1J102J	CHIP R	1.0K	J	1/16W		

L : Scandinavia K : USA P : Canada R : Mexico C : China I : Malaysia
Y : PX(Far East,Hawaii) T : England E : Europe G : Germany V : China(Shanghai)
Y : AAFES(Europe) X : Australia Q : Russia H : Korea M : Other Areas Δ indicates safety critical components .

* New Parts

Parts without **Parts No.** are not supplied.
Les articles non mentionnés dans le **Parts No.** ne sont pas fournis.
Teile ohne **Parts No.** werden nicht geliefert.

20

Ref. No	Address	New Parts	Parts No.	Description	Quantity	Unit	Weight	Destination	Remarks
R369-372			RK73GB1J472J	CHIP R	4.7K	J	1/16W		
R373,374			RK73GB1J100J	CHIP R	10	J	1/16W		
R375-378			RK73GB1J511J	CHIP R	510	J	1/16W		
R379,380			RK73GB1J471J	CHIP R	470	J	1/16W		
R381,382			RK73GB1J121J	CHIP R	120	J	1/16W		
R383,384			RK73GB1J100J	CHIP R	10	J	1/16W		
R385,386			RK73GB1J1R0J	CHIP R	1	J	1/16W		
R401			RK73FB2A100J	CHIP R	10	J	1/10W		
R402-404			RK73GB1J102J	CHIP R	1.0K	J	1/16W		
R405			RK73FB2A100J	CHIP R	10	J	1/10W		
R406			RK73FB2A1R0J	CHIP R	1	J	1/10W		
R407			RK73GB1J1R0J	CHIP R	1	J	1/16W		
R411,412			RK73GB1J182J	CHIP R	1.8K	J	1/16W		
R413,414			RK73GB1J242J	CHIP R	2.4K	J	1/16W		
R415,416			RK73GB1J102J	CHIP R	1.0K	J	1/16W		
R417,418			RK73GB1J122J	CHIP R	1.2K	J	1/16W		
R419			RK73GB1J472J	CHIP R	4.7K	J	1/16W		
R420			RK73GB1J273J	CHIP R	27K	J	1/16W		
R421			RK73GB1J472J	CHIP R	4.7K	J	1/16W		
R422			RK73GB1J273J	CHIP R	27K	J	1/16W		
R423,424			RK73GB1J100J	CHIP R	10	J	1/16W		
R425			RK73GB1J681J	CHIP R	680	J	1/16W		
R426			RK73GB1J123J	CHIP R	12K	J	1/16W		
R427			RK73GB1J681J	CHIP R	680	J	1/16W		
R428			RK73GB1J123J	CHIP R	12K	J	1/16W		
R429			RK73GB1J471J	CHIP R	470	J	1/16W		
R430			RK73GB1J183J	CHIP R	18K	J	1/16W		
R431			RK73GB1J121J	CHIP R	120	J	1/16W		
R432			RK73GB1J152J	CHIP R	1.5K	J	1/16W		
R433,434			RK73GB1J100J	CHIP R	10	J	1/16W		
R435,436			RK73GB1J1R0J	CHIP R	1	J	1/16W		
R451			RK73FB2A100J	CHIP R	10	J	1/10W		
R452-454			RK73GB1J102J	CHIP R	1.0K	J	1/16W		
R455			RK73FB2A100J	CHIP R	10	J	1/10W		
R456			RK73FB2A1R0J	CHIP R	1	J	1/10W		
R457			RK73GB1J1R0J	CHIP R	1	J	1/16W		
R461-468			RK73GB1J102J	CHIP R	1.0K	J	1/16W		
R469-472			RK73GB1J472J	CHIP R	4.7K	J	1/16W		
R473,474			RK73GB1J100J	CHIP R	10	J	1/16W		
R475-478			RK73GB1J511J	CHIP R	510	J	1/16W		
R479,480			RK73GB1J471J	CHIP R	470	J	1/16W		
R481,482			RK73GB1J121J	CHIP R	120	J	1/16W		
R483,484			RK73GB1J100J	CHIP R	10	J	1/16W		
R485,486			RK73GB1J1R0J	CHIP R	1	J	1/16W		
R550			RK73GB1J101J	CHIP R	100	J	1/16W		
R601			RK73FB2A1R0J	CHIP R	1	J	1/10W		
R602-605			RK73GB1J103J	CHIP R	10K	J	1/16W		
R606,607			RK73GB1J470J	CHIP R	47	J	1/16W		
R608			RK73GB1J103J	CHIP R	10K	J	1/16W		
R609			RK73FB2A1R0J	CHIP R	1	J	1/10W		
R610,611			RK73GB1J470J	CHIP R	47	J	1/16W		
R612-615			RK73GB1J103J	CHIP R	10K	J	1/16W		
R616-618			RK73FB2A1R0J	CHIP R	1	J	1/10W		
R619-621			RK73GB1J103J	CHIP R	10K	J	1/16W		
R622			RK73FB2A1R0J	CHIP R	1	J	1/10W		

L : Scandinavia K : USA P : Canada R : Mexico C : China I : Malaysia
Y : PX(Far East,Hawaii) T : England E : Europe G : Germany V : China(Shanghai)
Y : AAFES(Europe) X : Australia Q : Russia H : Korea M : Other Areas Δ indicates safety critical components .

PARTS LIST

KRF-X7775D/X7775D-S/VR-5080/5090

* New Parts

Parts without **Parts No.** are not supplied.Les articles non mentionnés dans le **Parts No.** ne sont pas fournis.Teile ohne **Parts No.** werden nicht geliefert.

21

Ref. No	Add-ress	New Parts	Parts No.	Description	Desti-nation	Re-marks
R623			RK73GB1J105J	CHIP R 1.0M J 1/16W		
R624			RK73GB1J102J	CHIP R 1.0K J 1/16W		
R625			RK73FB2A1R0J	CHIP R 1 J 1/10W		
R626			RK73GB1J103J	CHIP R 10K J 1/16W		
R627,628			RK73FB2A1R0J	CHIP R 1 J 1/10W		
R629			RK73GB1J103J	CHIP R 10K J 1/16W		
R630-639			RK73GB1J101J	CHIP R 100 J 1/16W		
R640-648			RK73FB2A1R0J	CHIP R 1 J 1/10W		
R649-652			RK73GB1J101J	CHIP R 100 J 1/16W		
R653			RK73FB2A1R0J	CHIP R 1 J 1/10W		
R654,655			RK73GB1J103J	CHIP R 10K J 1/16W		
R656			RK73FB2A1R0J	CHIP R 1 J 1/10W		
R657			RK73GB1J103J	CHIP R 10K J 1/16W		
R658			RK73GB1J101J	CHIP R 100 J 1/16W		
R659-664			RK73FB2A1R0J	CHIP R 1 J 1/10W		
R665-667			RK73GB1J101J	CHIP R 100 J 1/16W		
R668			RK73FB2A1R0J	CHIP R 1 J 1/10W		
R669-671			RK73GB1J101J	CHIP R 100 J 1/16W		
R672			RK73GB1J103J	CHIP R 10K J 1/16W		
R673			RK73GB1J101J	CHIP R 100 J 1/16W		
△ R674			RK73FB2A100J	CHIP R 10 J 1/10W		
R675			RK73FB2A1R0J	CHIP R 1 J 1/10W		
R701-708			RK73GB1J101J	CHIP R 100 J 1/16W		
R709,710			RK73GB1J472J	CHIP R 4.7K J 1/16W		
R711-719			RK73GB1J101J	CHIP R 100 J 1/16W		
R720			RK73GB1J472J	CHIP R 4.7K J 1/16W		
R721-723			RK73GB1J101J	CHIP R 100 J 1/16W		
R724-727			RK73FB2A1R0J	CHIP R 1 J 1/10W		
R728-731			RK73GB1J101J	CHIP R 100 J 1/16W		
R732-734			RK73FB2A1R0J	CHIP R 1 J 1/10W		
R801-854			RK73GB1J473J	CHIP R 47K J 1/16W		
R855			RK73GB1J105J	CHIP R 1.0M J 1/16W		
R856			RK73FB2A1R0J	CHIP R 1 J 1/10W		
R857			RK73GB1J183J	CHIP R 18K J 1/16W		
R858			RK73GB1J123J	CHIP R 12K J 1/16W		
R859			RK73GB1J183J	CHIP R 18K J 1/16W		
R860			RK73GB1J473J	CHIP R 47K J 1/16W		
R861			RK73FB2A1R0J	CHIP R 1 J 1/10W		
R862-864			RK73GB1J473J	CHIP R 47K J 1/16W		
R865,866			RK73GB1J102J	CHIP R 1.0K J 1/16W		
R867			RK73FB2A1R0J	CHIP R 1 J 1/10W		
R868,869			RK73GB1J473J	CHIP R 47K J 1/16W		
R871-875			RK73GB1J471J	CHIP R 470 J 1/16W		
R876			RK73GB1J512J	CHIP R 5.1K J 1/16W		
R877-895			RK73GB1J471J	CHIP R 470 J 1/16W		
R896-900			RK73GB1J221J	CHIP R 220 J 1/16W		
R901-905			RK73GB1J471J	CHIP R 470 J 1/16W		
R911-915			RK73GB1J473J	CHIP R 47K J 1/16W		
R951-954			RK73FB2A181J	CHIP R 180 J 1/10W		
△ R955-960			RK73FB2A1R0J	CHIP R 1 J 1/10W		
△ R961			RK73GB1J102J	CHIP R 1.0K J 1/16W		
△ R962-967			RK73FB2A1R0J	CHIP R 1 J 1/10W		
△ R969-972			RK73FB2A1R0J	CHIP R 1 J 1/10W		
△ R973-976			RK73FB2A390J	CHIP R 39 J 1/10W		
R999			RK73GB1J1R0J	CHIP R 1 J 1/16W		

L : Scandinavia

K : USA

P : Canada

R : Mexico

C : China

I : Malaysia

Y : PX(Far East,Hawaii)

T : England

E : Europe

G : Germany

V : China(Shanghai)

Y : AAFES(Europe)

X : Australia

Q : Russia

H : Korea

M : Other Areas

△ indicates safety critical components .

* New Parts

Parts without **Parts No.** are not supplied.Les articles non mentionnés dans le **Parts No.** ne sont pas fournis.Teile ohne **Parts No.** werden nicht geliefert.

22

Ref. No	Add-ress	New Parts	Parts No.	Description	Desti-nation	Re-marks
D3 -6			DA204U	DIODE		
D3 -6			1SS302	DIODE		
IC1			TC74HC04AF	IC(HEX INVERTER SMD)	K1P2	
IC2			TC74HC04AF	IC(HEX INVERTER SMD)		
IC3, 4			TC74HC04AF	IC(HEX INVERTER SMD)	K1P2	
IC5			TC74HC151AF	MOS-IC		
IC6		*	AK4112BVF	MOS-IC		
IC7		*	AK5383VF	MOS-IC		
IC8, 9			NJM4565MD	IC(OP AMP X2)		
IC11			AK4393-VF	MOS-IC		
IC11		*	AK4393VF	MOS-IC		
IC12,13			NJM4565MD	IC(OP AMP X2)		
IC14			AK4393-VF	MOS-IC		
IC14		*	AK4393VF	MOS-IC		
IC15,16			NJM4565MD	IC(OP AMP X2)		
IC17			AK4393-VF	MOS-IC		
IC17		*	AK4393VF	MOS-IC		
IC18,19			NJM4565MD	IC(OP AMP X2)		
IC20			AK4393-VF	MOS-IC		
IC20		*	AK4393VF	MOS-IC		
IC21,22			NJM4565MD	IC(OP AMP X2)		
IC31		*	ADSST-A-3525	MOS-IC		
IC32		*	49BV008A1ALA	MOS-IC		
IC33,34			HY57V16160DTC	MEMORY IC		
IC35			TC7S04F	IC(2CH NAND GATE)		
IC36,37			TC7SHU04FU	MOS-IC		
IC38			TC74HC08AF	MOS-IC		
IC39,40		*	TC74LVX573F	MOS-IC		
IC41			TC7SH32F	MOS-IC		
IC42			TC7SH02F	MOS-IC		
IC43		*	UPD784224K507	MI-COM IC		
IC44			TC74VHC125F	MOS-IC		
IC45			TC7WH34FK	MOS-IC		
△ IC51			UPC29L33T	ANALOGUE IC		
△ IC52		*	PQ3DZ13	ANALOGUE IC		
△ IC53,54		*	UPC29M05T	ANALOGUE IC		
CONTROL UNIT (X11-389/390X-XX)						
C1 -14			CC73GCH1H221J	CHIP C 220PF	J	
C45 -48			CC73GCH1H101J	CHIP C 100PF	J	
C49, 50			CE04KW1H470M	ELECTRO 47UF	50WV	
C53, 54			CE04KW1H100M	ELECTRO 10UF	50WV	
C55, 56			CC73GCH1H221J	CHIP C 220PF	J	
C57, 58			CE04KW1A101M	ELECTRO 100UF	10WV	
C61, 62			CQ93FMG1H123J	MYLAR 0.012UF	J	
C63, 64			CQ93FMG1H332J	MYLAR 3300PF	J	
C65, 66			CE04KW1H4R7M	ELECTRO 4.7UF	50WV	
C67, 68			CC73GCH1H101J	CHIP C 100PF	J	
C69, 70			CC73GCH1H181J	CHIP C 180PF	J	
C71 -78			CC73GCH1H101J	CHIP C 100PF	J	
C81 -84			CC73GCH1H101J	CHIP C 100PF	J	
C85, 86			CE04KW1H4R7M	ELECTRO 4.7UF	50WV	
C87 -90			CC73GCH1H101J	CHIP C 100PF	J	
C91, 92			CE04KW1H010M	ELECTRO 1.0UF	50WV	
C93, 94			CE04KW1H2R2M	ELECTRO 2.2UF	50WV	

L : Scandinavia

K : USA

P : Canada

R : Mexico

C : China

I : Malaysia

Y : PX(Far East,Hawaii)

T : England

E : Europe

G : Germany

V : China(Shanghai)

Y : AAFES(Europe)

X : Australia

Q : Russia

H : Korea

M : Other Areas

△ indicates safety critical components .

* New Parts

Parts without **Parts No.** are not supplied.
Les articles non mentionnés dans le **Parts No.** ne sont pas fournis.
Teile ohne **Parts No.** werden nicht geliefert.

23

Ref. No	Add-ress	New Parts	Parts No.	Description	Desti-nation	Re-marks
C95 -100			CC73GCH1H101J	CHIP C	100PF	J
C101,102			CE04KW1H4R7M	ELECTRO	4.7UF	50WV
C103,104			CC73GCH1H101J	CHIP C	100PF	J
C105-107			CC73GCH1H102J	CHIP C	1000PF	J
C108			CE04KW1H220M	ELECTRO	22UF	50WV
C111,112			CC73GCH1H101J	CHIP C	100PF	J
C113,114			CC73GCH1H561J	CHIP C	560PF	J
C115,116			CC73GCH1H101J	CHIP C	100PF	J
C117-120			CK73FB1C104K	CHIP C	0.10UF	K
C121,122			CC73GCH1H101J	CHIP C	100PF	J
C123,124			CE04KW1H4R7M	ELECTRO	4.7UF	50WV
C125,126			CC45FSL1H820J	CERAMIC	82PF	J
C127,128			CE04KW1H220M	ELECTRO	22UF	50WV
C129,130			CC45FSL1H330J	CERAMIC	33PF	J
C131,132			CC73GCH1H101J	CHIP C	100PF	J
C133			CE04KW1H100M	ELECTRO	10UF	50WV
C135			CC73GCH1H101J	CHIP C	100PF	J
C137			CC45FSL1H020C	CERAMIC	2.0PF	C
C138			CC45FSL1H030C	CERAMIC	3.0PF	C
C139,140			CC73GCH1H101J	CHIP C	100PF	J
C141,142			CE04KW1H4R7M	ELECTRO	4.7UF	50WV
C143,144			CC73GCH1H101J	CHIP C	100PF	J
C145,146			CC73GCH1H561J	CHIP C	560PF	J
C147-150			CK73FB1C104K	CHIP C	0.10UF	K
C151,152			CE04KW1H4R7M	ELECTRO	4.7UF	50WV
C153,154			CC45FSL1H470J	CERAMIC	47PF	J
C155,156			CE04KW1H220M	ELECTRO	22UF	50WV
C157,158			CC45FSL1H330J	CERAMIC	33PF	J
C159-163			CC73GCH1H101J	CHIP C	100PF	J
C165			CC45FSL1H020C	CERAMIC	2.0PF	C
C166			CC45FSL1H030C	CERAMIC	3.0PF	C
C167			CE04KW1H100M	ELECTRO	10UF	50WV
C169,170			CC73GCH1H101J	CHIP C	100PF	J
C181,182			CE04KW1H4R7M	ELECTRO	4.7UF	50WV
C183,184			CC73GCH1H101J	CHIP C	100PF	J
C191,192			CE04KW1H4R7M	ELECTRO	4.7UF	50WV
C193,194			CC45FSL1H470J	CERAMIC	47PF	J
C195,196			CE04KW1H220M	ELECTRO	22UF	50WV
C197			CC45FSL1H330J	CERAMIC	33PF	J
C198			CC45FSL1H101J	CERAMIC	100PF	J
C199-204			CC73GCH1H101J	CHIP C	100PF	J
C205,206			CC45FSL1H020C	CERAMIC	2.0PF	C
C207			CE04KW1H100M	ELECTRO	10UF	50WV
C209,210			CC73GCH1H101J	CHIP C	100PF	J
C211,212			CE04KW1H4R7M	ELECTRO	4.7UF	50WV
C213-216			CC73GCH1H101J	CHIP C	100PF	J
C221,222			CE04KW1H4R7M	ELECTRO	4.7UF	50WV
C223,224			CC45FSL1H470J	CERAMIC	47PF	J
C225,226			CE04KW1H220M	ELECTRO	22UF	50WV
C227,228			CC45FSL1H330J	CERAMIC	33PF	J
C229-233			CC73GCH1H101J	CHIP C	100PF	J
C234			CE04KW1H100M	ELECTRO	10UF	50WV
C235			CC45FSL1H020C	CERAMIC	2.0PF	C
C236			CC45FSL1H030C	CERAMIC	3.0PF	C
C301-310			CC73GCH1H221J	CHIP C	220PF	J

L : Scandinavia K : USA P : Canada R : Mexico C : China I : Malaysia
Y : PX(Far East,Hawaii) T : England E : Europe G : Germany V : China(Shanghai)
Y : AAFES(Europe) X : Australia Q : Russia H : Korea M : Other Areas Δ indicates safety critical components .

* New Parts

Parts without **Parts No.** are not supplied.
Les articles non mentionnés dans le **Parts No.** ne sont pas fournis.
Teile ohne **Parts No.** werden nicht geliefert.

24

Ref. No	Add-ress	New Parts	Parts No.	Description	Desti-nation	Re-marks
C311,312			CC73GCH1H221J	CHIP C	220PF	J
C313-318			CC73GCH1H221J	CHIP C	220PF	J
C351-356			CE04KW1H2R2M	ELECTRO	2.2UF	50WV
C357-376			CC73GCH1H101J	CHIP C	100PF	J
C377,378			CK73GB1H103K	CHIP C	0.010UF	K
C381,382			CE04KW1H220M	ELECTRO	22UF	50WV
C383,384			CE04KW1H100M	ELECTRO	10UF	50WV
C401,402			CE04KW1H2R2M	ELECTRO	2.2UF	50WV
C403-410			CC73GCH1H101J	CHIP C	100PF	J
C411,412			CE04KW1H220M	ELECTRO	22UF	50WV
C413-415			CE04KW1H4R7M	ELECTRO	4.7UF	50WV
C421			CE04KW1H100M	ELECTRO	10UF	50WV
C422,423			CC73GCH1H101J	CHIP C	100PF	J
C425			CE04KW1H220M	ELECTRO	22UF	50WV
C427			CC73GCH1H101J	CHIP C	100PF	J
C431-440			CC73GCH1H101J	CHIP C	100PF	J
C441,442			CE04KW1H220M	ELECTRO	22UF	50WV
C443,444			CC73GCH1H101J	CHIP C	100PF	J
C451,452			CE04KW1H2R2M	ELECTRO	2.2UF	50WV
C453,454			CC73GCH1H101J	CHIP C	100PF	J
C455,456			CE04KW1H220M	ELECTRO	22UF	50WV
C457-462			CC73GCH1H101J	CHIP C	100PF	J
C463,464			CE04KW1H4R7M	ELECTRO	4.7UF	50WV
C465,466			CC73GCH1H101J	CHIP C	100PF	J
C467			CE04KW1H100M	ELECTRO	10UF	50WV
C469,470			CC73GCH1H101J	CHIP C	100PF	J
C471,472			CE04KW1H010M	ELECTRO	1.0UF	50WV
C473,474			CC73GCH1H561J	CHIP C	560PF	J
C475,476			CE04KW1H010M	ELECTRO	1.0UF	50WV
C477,478			CC73GCH1H270J	CHIP C	27PF	J
C479,480			CK73GB1H562K	CHIP C	5600PF	K
C481,482			CK73FB1H183K	CHIP C	0.018UF	K
C483,484			CE04KW1H100M	ELECTRO	10UF	50WV
C485,486			CK73FB1H153K	CHIP C	0.015UF	K
C487,488			CK73FB1H683K	CHIP C	0.068UF	K
C489,490			CC73GCH1H821J	CHIP C	820PF	J
C491-495			CC73GCH1H101J	CHIP C	100PF	J
C501-506			CC73GCH1H101J	CHIP C	100PF	J
C509,510			CC73GCH1H101J	CHIP C	100PF	J
C513-518			CC73GCH1H101J	CHIP C	100PF	J
C549,550			CC73GCH1H101J	CHIP C	100PF	J
C551-554			CE04KW1H4R7M	ELECTRO	4.7UF	50WV
C555,556			CC45FSL1H101J	CERAMIC	100PF	J
C557,558			CE04KW1H220M	ELECTRO	22UF	50WV
C559,560			CC45FSL1H330J	CERAMIC	33PF	J
C561,562			CC73GCH1H101J	CHIP C	100PF	J
C563			CC45FSL1H020C	CERAMIC	2.0PF	C
C564			CC45FSL1H030C	CERAMIC	3.0PF	C
C565,566			CK73GB1H103K	CHIP C	0.010UF	K
C567			CC73GCH1H101J	CHIP C	100PF	J
C568			CE04KW1H100M	ELECTRO	10UF	50WV
CN1			E40-8319-05	FLAT CABLE CONNECTOR		
CN2			E40-8250-05	FLAT CABLE CONNECTOR		
CN3			E40-8354-05	FLAT CABLE CONNECTOR		

L : Scandinavia K : USA P : Canada R : Mexico C : China I : Malaysia
Y : PX(Far East,Hawaii) T : England E : Europe G : Germany V : China(Shanghai)
Y : AAFES(Europe) X : Australia Q : Russia H : Korea M : Other Areas Δ indicates safety critical components .

PARTS LIST

KRF-X7775D/X7775D-S/VR-5080/5090

* New Parts
Parts without **Parts No.** are not supplied.
Les articles non mentionnés dans le **Parts No.** ne sont pas fournis.
Teile ohne **Parts No.** werden nicht geliefert.

25

Ref. No	Add-ress	New Parts	Parts No.	Description	Desti-nation	Re-marks
CN11			E40-8318-05	FLAT CABLE CONNECTOR		
CN12,13		*	E40-9835-05	SOCKET FOR PIN ASSY		
J1 ,2			E63-1112-05	PIN JACK	E2V	
J1 ,2			E63-1112-05	PIN JACK	KP1E1	
J1 ,2			E63-1112-05	PIN JACK	Y1M1X1	
J1 ,2			E63-1113-05	PIN JACK	K1P2	
J11			E63-1111-05	PIN JACK	K1P2	
J11			E63-1164-05	PIN JACK	E2V	
J11			E63-1164-05	PIN JACK	KP1E1	
J11			E63-1164-05	PIN JACK	Y1M1X1	
J12			E63-1111-05	PIN JACK	K1P2	
J13			E63-1114-05	PIN JACK	E2V	
J13			E63-1114-05	PIN JACK	KP1E1	
J13			E63-1114-05	PIN JACK	Y1M1X1	
J13			E63-1115-05	PIN JACK	K1P2	
J14			E63-1163-05	PIN JACK	E2V	
J14			E63-1163-05	PIN JACK	KP1E1	
J14			E63-1163-05	PIN JACK	Y1M1X1	
R1 ,2			RK73GB1J102J	CHIP R		1.0K J 1/16W
R3 ,4			RK73GB1J222J	CHIP R		2.2K J 1/16W
R5 ,10			RK73GB1J102J	CHIP R		1.0K J 1/16W
R11 ,12			RK73GB1J222J	CHIP R		2.2K J 1/16W
R13 ,14			RK73GB1J102J	CHIP R		1.0K J 1/16W
R15 ,28			RK73GB1J474J	CHIP R		470K J 1/16W
R45 ,48			RK73GB1J102J	CHIP R		1.0K J 1/16W
R51 ,52			RK73GB1J224J	CHIP R		220K J 1/16W
R53 ,54			RK73GB1J222J	CHIP R		2.2K J 1/16W
R55 ,56			RK73GB1J303J	CHIP R		30K J 1/16W
R57 ,58			RK73GB1J361J	CHIP R		360 J 1/16W
R59 ,60			RK73GB1J101J	CHIP R		100 J 1/16W
R61 ,62			RK73GB1J274J	CHIP R		270K J 1/16W
R63 ,64			RK73GB1J223J	CHIP R		22K J 1/16W
R65 ,66			RK73GB1J473J	CHIP R		47K J 1/16W
R67 ,68			RK73GB1J102J	CHIP R		1.0K J 1/16W
R72			RK73GB1J103J	CHIP R		10K J 1/16W
R75 ,76			RK73GB1J102J	CHIP R		1.0K J 1/16W
R77 ,78			RK73GB1J100J	CHIP R		10 J 1/16W
R80			RK73GB1J681J	CHIP R		680 J 1/16W
R81 ,82			RK73GB1J472J	CHIP R		4.7K J 1/16W
R83 ,84			RK73GB1J102J	CHIP R		1.0K J 1/16W
R85 ,86			RK73GB1J101J	CHIP R		100 J 1/16W
R87 ,88			RK73GB1J224J	CHIP R		220K J 1/16W
R89 ,90			RK73GB1J471J	CHIP R		470 J 1/16W
R91 ,92			RK73GB1J474J	CHIP R		470K J 1/16W
R93 ,94			RK73GB1J471J	CHIP R		470 J 1/16W
R95 ,96			RK73GB1J224J	CHIP R		220K J 1/16W
R97 ,98			RK73GB1J101J	CHIP R		100 J 1/16W
R99 ,100			RK73GB1J470J	CHIP R		47 J 1/16W
R111,112			RK73GB1J104J	CHIP R		100K J 1/16W
R113,114			RK73GB1J224J	CHIP R		220K J 1/16W
R115,116			RK73GB1J822J	CHIP R		8.2K J 1/16W
R117,118			RK73GB1J470J	CHIP R		47 J 1/16W
R119,120			RK73GB1J105J	CHIP R		1.0M J 1/16W
R121,122			RK73GB1J124J	CHIP R		120K J 1/16W

L : Scandinavia K : USA P : Canada R : Mexico C : China I : Malaysia
Y : PX(Far East,Hawaii) T : England E : Europe G : Germany V : China(Shanghai)
Y : AAFES(Europe) X : Australia Q : Russia H : Korea M : Other Areas Δ indicates safety critical components.

* New Parts
Parts without **Parts No.** are not supplied.
Les articles non mentionnés dans le **Parts No.** ne sont pas fournis.
Teile ohne **Parts No.** werden nicht geliefert.

26

Ref. No	Add-ress	New Parts	Parts No.	Description	Desti-nation	Re-marks
R123,124			RK73GB1J302J	CHIP R		3.0K J 1/16W
R125,126			RK73GB1J133J	CHIP R		13K J 1/16W
R127,128			RK73GB1J100J	CHIP R		10 J 1/16W
R129			RK73GB1J102J	CHIP R		1.0K J 1/16W
R130			RK73GB1J103J	CHIP R		10K J 1/16W
R131,132			RK73GB1J2R2J	CHIP R		2.2 J 1/16W
R133,134			RK73GB1J102J	CHIP R		1.0K J 1/16W
R141,142			RK73GB1J104J	CHIP R		100K J 1/16W
R143,144			RK73GB1J224J	CHIP R		220K J 1/16W
R145,146			RK73GB1J822J	CHIP R		8.2K J 1/16W
R147,148			RK73GB1J470J	CHIP R		47 J 1/16W
R149,150			RK73GB1J102J	CHIP R		1.0K J 1/16W
R151,152			RK73GB1J124J	CHIP R		120K J 1/16W
R153,154			RK73GB1J103J	CHIP R		10K J 1/16W
R155,156			RK73GB1J332J	CHIP R		3.3K J 1/16W
R157,158			RK73GB1J163J	CHIP R		16K J 1/16W
R159,160			RK73GB1J133J	CHIP R		13K J 1/16W
R161,162			RK73GB1J470J	CHIP R		47 J 1/16W
R163,164			RK73GB1J100J	CHIP R		10 J 1/16W
R165			RK73GB1J102J	CHIP R		1.0K J 1/16W
R166			RK73GB1J472J	CHIP R		4.7K J 1/16W
R167,168			RK73GB1J105J	CHIP R		1.0M J 1/16W
R169			RK73GB1J472J	CHIP R		4.7K J 1/16W
R171,172			RK73GB1J100J	CHIP R		10 J 1/16W
R173,174			RK73GB1J2R2J	CHIP R		2.2 J 1/16W
R181,182			RK73GB1J104J	CHIP R		100K J 1/16W
R183,184			RK73GB1J102J	CHIP R		1.0K J 1/16W
R187,188			RK73GB1J470J	CHIP R		47 J 1/16W
R189,190			RK73GB1J105J	CHIP R		1.0M J 1/16W
R191,192			RK73GB1J124J	CHIP R		120K J 1/16W
R193,194			RK73GB1J103J	CHIP R		10K J 1/16W
R195			RK73GB1J332J	CHIP R		3.3K J 1/16W
R196			RK73GB1J472J	CHIP R		4.7K J 1/16W
R197			RK73GB1J163J	CHIP R		16K J 1/16W
R198			RK73GB1J153J	CHIP R		15K J 1/16W
R199			RK73GB1J133J	CHIP R		13K J 1/16W
R200			RK73GB1J333J	CHIP R		33K J 1/16W
R201,202			RK73GB1J100J	CHIP R		10 J 1/16W
R203			RK73GB1J470J	CHIP R		47 J 1/16W
R204			RK73GB1J102J	CHIP R		1.0K J 1/16W
R205,206			RK73GB1J2R2J	CHIP R		2.2 J 1/16W
R211,212			RK73GB1J104J	CHIP R		100K J 1/16W
R213,214			RK73GB1J102J	CHIP R		1.0K J 1/16W
R217,218			RK73GB1J470J	CHIP R		47 J 1/16W
R219,220			RK73GB1J105J	CHIP R		1.0M J 1/16W
R221,222			RK73GB1J124J	CHIP R		120K J 1/16W
R223,224			RK73GB1J103J	CHIP R		10K J 1/16W
R225,226			RK73GB1J332J	CHIP R		3.3K J 1/16W
R227,228			RK73GB1J163J	CHIP R		16K J 1/16W
R229,230			RK73GB1J133J	CHIP R		13K J 1/16W
R231,232			RK73GB1J470J	CHIP R		47 J 1/16W
R233,234			RK73GB1J100J	CHIP R		10 J 1/16W
R235			RK73GB1J102J	CHIP R		1.0K J 1/16W
R237,238			RK73GB1J2R2J	CHIP R		2.2 J 1/16W
R301,302			RK73GB1J222J	CHIP R		2.2K J 1/16W

L : Scandinavia K : USA P : Canada R : Mexico C : China I : Malaysia
Y : PX(Far East,Hawaii) T : England E : Europe G : Germany V : China(Shanghai)
Y : AAFES(Europe) X : Australia Q : Russia H : Korea M : Other Areas Δ indicates safety critical components.

PARTS LIST

KRF-X7775D/X7775D-S/MR-5080/5090

* New Parts

Parts without **Parts No.** are not supplied.
Les articles non mentionnés dans le **Parts No.** ne sont pas fournis.
Teile ohne **Parts No.** werden nicht geliefert.

27

Ref. No	Add-ress	New Parts	Parts No.	Description	Desti-nation	Re-marks
R303,304			RK73GB1J102J	CHIP R 1.0K J 1/16W		
R305,306			RK73GB1J222J	CHIP R 2.2K J 1/16W		
R307-310			RK73GB1J102J	CHIP R 1.0K J 1/16W		
R311,312			RK73GB1J102J	CHIP R 1.0K J 1/16W		
R313-318			RK73GB1J102J	CHIP R 1.0K J 1/16W	K1P2	
R319-328			RK73GB1J474J	CHIP R 470K J 1/16W		
R319,330			RK73GB1J474J	CHIP R 470K J 1/16W	K1P2	
R331-336			RK73GB1J474J	CHIP R 470K J 1/16W		
R351-356			RK73GB1J471J	CHIP R 470 J 1/16W		
R357-362			RK73GB1J224J	CHIP R 220K J 1/16W		
R363-366			RK73GB1J101J	CHIP R 100 J 1/16W		
R367			RK73GB1J472J	CHIP R 4.7K J 1/16W		
R368			RK73GB1J101J	CHIP R 100 J 1/16W		
R369-372			RK73GB1J470J	CHIP R 47 J 1/16W		
R373			RK73GB1J222J	CHIP R 2.2K J 1/16W		
R381,382			RK73GB1J470J	CHIP R 47 J 1/16W		
R383,384			RK73GB1J224J	CHIP R 220K J 1/16W		
R385-390			RK73GB1J472J	CHIP R 4.7K J 1/16W		
R391,392			RK73GB1J622J	CHIP R 6.2K J 1/16W		
R401,402			RK73GB1J224J	CHIP R 220K J 1/16W		
R403,404			RK73GB1J101J	CHIP R 100 J 1/16W		
R421			RK73GB1J224J	CHIP R 220K J 1/16W		
R422			RK73GB1J101J	CHIP R 100 J 1/16W		
R423,424			RK73GB1J472J	CHIP R 4.7K J 1/16W		
R425			RK73GB1J470J	CHIP R 47 J 1/16W		
R427,428			RK73GB1J104J	CHIP R 100K J 1/16W		
R429,430			RK73GB1J100J	CHIP R 10 J 1/16W		
R431,432			RK73GB1J152J	CHIP R 1.5K J 1/16W		
R433,434			RK73GB1J272J	CHIP R 2.7K J 1/16W		
R435-442			RK73GB1J472J	CHIP R 4.7K J 1/16W		
R443,444			RK73GB1J104J	CHIP R 100K J 1/16W		
R451			RK73GB1J332J	CHIP R 3.3K J 1/16W		
R452			RK73GB1J103J	CHIP R 10K J 1/16W		
R453			RK73GB1J152J	CHIP R 1.5K J 1/16W		
R454			RK73GB1J103J	CHIP R 10K J 1/16W		
R455,456			RK73GB1J102J	CHIP R 1.0K J 1/16W		
R457,458			RK73GB1J224J	CHIP R 220K J 1/16W		
R459,460			RK73GB1J472J	CHIP R 4.7K J 1/16W		
R461,462			RK73GB1J224J	CHIP R 220K J 1/16W		
R463,464			RK73GB1J472J	CHIP R 4.7K J 1/16W		
R465,466			RK73GB1J470J	CHIP R 47 J 1/16W		
R467-469			RK73GB1J104J	CHIP R 100K J 1/16W		
R471,472			RK73GB1J822J	CHIP R 8.2K J 1/16W		
R473,474			RK73GB1J202J	CHIP R 2.0K J 1/16W		
R475,476			RK73GB1J124J	CHIP R 120K J 1/16W		
R477,478			RK73GB1J433J	CHIP R 43K J 1/16W		
R479,480			RK73GB1J184J	CHIP R 180K J 1/16W		
R481,482			RK73GB1J394J	CHIP R 390K J 1/16W		
R483-486			RK73GB1J392J	CHIP R 3.9K J 1/16W		
R487,488			RK73GB1J821J	CHIP R 820 J 1/16W		
R489,490			RK73GB1J163J	CHIP R 16K J 1/16W		
R491,492			RK73GB1J684J	CHIP R 680K J 1/16W		
R493,494			RK73GB1J223J	CHIP R 22K J 1/16W		
R495,496			RK73GB1J102J	CHIP R 1.0K J 1/16W		
R497			RK73GB1J103J	CHIP R 10K J 1/16W		

L : Scandinavia K : USA P : Canada R : Mexico C : China I : Malaysia
Y : PX(Far East,Hawaii) T : England E : Europe G : Germany V : China(Shanghai)
Y : AAFES(Europe) X : Australia Q : Russia H : Korea M : Other Areas Δ indicates safety critical components .

* New Parts

Parts without **Parts No.** are not supplied.
Les articles non mentionnés dans le **Parts No.** ne sont pas fournis.
Teile ohne **Parts No.** werden nicht geliefert.

28

Ref. No	Add-ress	New Parts	Parts No.	Description	Desti-nation	Re-marks
R498,499			RK73GB1J472J	CHIP R 4.7K J 1/16W		
R500,501			RK73GB1J102J	CHIP R 1.0K J 1/16W		
R502			RK73GB1J103J	CHIP R 10K J 1/16W		
R503			RK73GB1J102J	CHIP R 1.0K J 1/16W		
R504			RK73GB1J103J	CHIP R 10K J 1/16W		
R505,506			RK73GB1J472J	CHIP R 4.7K J 1/16W		
R507-520			RK73GB1J102J	CHIP R 1.0K J 1/16W		
R549-552			RK73GB1J104J	CHIP R 100K J 1/16W		
R553,554			RK73GB1J103J	CHIP R 10K J 1/16W		
R555,556			RK73GB1J332J	CHIP R 3.3K J 1/16W		
R557,558			RK73GB1J163J	CHIP R 16K J 1/16W		
R559,560			RK73GB1J133J	CHIP R 13K J 1/16W		
R561,562			RK73GB1J470J	CHIP R 47 J 1/16W		
R563			RK73GB1J103J	CHIP R 10K J 1/16W		
R564			RK73GB1J102J	CHIP R 1.0K J 1/16W		
R565,566			RK73GB1J2R2J	CHIP R 2.2 J 1/16W		
R567,568			RK73GB1J100J	CHIP R 10 J 1/16W		
W201-204			R92-1963-05	JUMPER WIRE (RESISTOR TYPE)		
W205,206			R92-0679-05	CHIP R 0 OHM		
W207-215			R92-1963-05	JUMPER WIRE (RESISTOR TYPE)		
W501-539			R92-1963-05	JUMPER WIRE (RESISTOR TYPE)		
D3 ,4			MA111	DIODE		
D5 -8			DA204U	DIODE		
D5 -8			1SS302	DIODE		
IC1			NJM4580ED	ANALOGUE IC		
IC2			NJU7312AM	MOS-IC		
IC3			NJU7313AM	ANALOGUE IC		
IC4 ,5			NJM4565M	ANALOGUE IC		
IC6		*	TC9459N	MOS-IC		
IC7			NJM4565M	ANALOGUE IC		
IC8		*	TC9459N	MOS-IC		
IC9			NJM4565MD	IC(OP AMP X2)		
IC10		*	TC9459N	MOS-IC		
IC11			NJM4565MD	IC(OP AMP X2)		
IC12		*	TC9459N	MOS-IC		
IC13			NJM4565MD	IC(OP AMP X2)		
IC21			NJU7312AM	MOS-IC		
IC22			NJU7313AM	ANALOGUE IC		
IC23			NJU7311AM	MOS-IC		
IC24			NJU7313AM	ANALOGUE IC		
IC25-28			NJM4565MD	IC(OP AMP X2)		
IC29-33			NJM4565M	ANALOGUE IC		
IC34			TC9184AP	MOS-IC		
IC35		*	TC9459N	MOS-IC		
IC36			NJM4565M	ANALOGUE IC		
Q1 -8			2SC2878(B)	TRANSISTOR		
Q11 ,12			2SC2878(B)	TRANSISTOR		
Q13			2SA1576A(R,S)	TRANSISTOR		
Q13			2SA1586(Y,GR)	TRANSISTOR		
Q14			DTC124EUA	DIGITAL TRANSISTOR		
Q14			UN5212	DIGITAL TRANSISTOR		
Q15 -18			2SC2878(B)	TRANSISTOR		

L : Scandinavia K : USA P : Canada R : Mexico C : China I : Malaysia
Y : PX(Far East,Hawaii) T : England E : Europe G : Germany V : China(Shanghai)
Y : AAFES(Europe) X : Australia Q : Russia H : Korea M : Other Areas Δ indicates safety critical components .

PARTS LIST

KRF-X7775D/X7775D-S/VR-5080/5090

* New Parts

Parts without **Parts No.** are not supplied.Les articles non mentionnés dans le **Parts No.** ne sont pas fournis.Teile ohne **Parts No.** werden nicht geliefert.

29

Ref. No	Add-ress	New Parts	Parts No.	Description	Desti-nation	Re-marks
SUB-CIRCUIT UNIT (X13-784/785X-XX)						
C4			C90-1826-05	BACKUP-C	0.047F	5.5WV
C5			CE04KW1A101M	ELECTRO	100UF	10WV
C6			CK73GF1E104Z	CHIP C	0.10UF	Z
C7			CK73GB1H103K	CHIP C	0.010UF	K
C8			CE04KW1H010M	ELECTRO	1.0UF	50WV
C9 ,10			CK73GB1H103K	CHIP C	0.010UF	K
C11			CE04KW1E470M	ELECTRO	47UF	25WV
C12			CE04KW1A101M	ELECTRO	100UF	10WV
C13 ,14			CK73GF1E104Z	CHIP C	0.10UF	Z
C20			CK73GF1E104Z	CHIP C	0.10UF	Z
C21 ,22			CC73GCH1H101J	CHIP C	100PF	J
C23 ,24			CK73GB1H103K	CHIP C	0.010UF	K
C41			CE04KW1E102M	ELECTRO	1000UF	25WV
C42			CE04KW1H100M	ELECTRO	10UF	50WV
C45 -50			CE04KW1H100M	ELECTRO	10UF	50WV
C51			CE04KW1E221M	ELECTRO	220UF	25WV
C52			CE04KW1E101M	ELECTRO	100UF	25WV
C98 ,99			CE04KW1H100M	ELECTRO	10UF	50WV
C101,102			CC73GCH1H560J	CHIP C	56PF	J
C110			CK73GB1H472K	CHIP C	4700PF	K
C201			CE04KW1H010M	ELECTRO	1.0UF	50WV
C202			CK73GB1H472K	CHIP C	4700PF	K
C229			CC73GCH1H102J	CHIP C	1000PF	J
C231			CE04KW1H100M	ELECTRO	10UF	50WV
C232			CC73GCH1H331J	CHIP C	330PF	J
C233			CC73GCH1H561J	CHIP C	560PF	J
C234,235			CC73GCH1H220J	CHIP C	22PF	J
C236			CE04KW1H100M	ELECTRO	10UF	50WV
C237			CK73GB1H472K	CHIP C	4700PF	K
C300			CK45FF1H103Z	CERAMIC	0.010UF	Z
C301,302			CE04KW1V102M	ELECTRO	1000UF	35WV
C307			CC73GCH1H102J	CHIP C	1000PF	J
C308			CC73GCH1H101J	CHIP C	100PF	J
C309			CE04KW1H100M	ELECTRO	10UF	50WV
C310			CE04KW1E221M	ELECTRO	220UF	25WV
C311,312			CE04KW1E470M	ELECTRO	47UF	25WV
C320			CK45FF1H103Z	CERAMIC	0.010UF	Z
C321			CE04KW1C472M	ELECTRO	4700UF	16WV
C322			CE04KW1E101M	ELECTRO	100UF	25WV
C323			CE04KW1A101M	ELECTRO	100UF	10WV
C328,329			CE04KW1E470M	ELECTRO	47UF	25WV
C330			CK45FF1H103Z	CERAMIC	0.010UF	Z
C331			CE04KW1V102M	ELECTRO	1000UF	35WV
C333,334			CE04KW1E470M	ELECTRO	47UF	25WV
C410			CE04KW1A101M	ELECTRO	100UF	10WV
C501-505			CC73GCH1H101J	CHIP C	100PF	J
C506			CC73GCH1H101J	CHIP C	100PF	J
C507,508			CC73GCH1H101J	CHIP C	100PF	J
C509,510			CE04KW1A471M	ELECTRO	470UF	10WV
C511-514			CE04KW1A101M	ELECTRO	100UF	10WV
C515			CE04KW1A101M	ELECTRO	100UF	10WV
C517			CK73GB1H103K	CHIP C	0.010UF	K
C518			CE04KW1A101M	ELECTRO	100UF	10WV

L : Scandinavia K : USA P : Canada R : Mexico C : China I : Malaysia
 Y : PX(Far East,Hawaii) T : England E : Europe G : Germany V : China(Shanghai)
 Y : AAFES(Europe) X : Australia Q : Russia H : Korea M : Other Areas Δ indicates safety critical components.

* New Parts

Parts without **Parts No.** are not supplied.Les articles non mentionnés dans le **Parts No.** ne sont pas fournis.Teile ohne **Parts No.** werden nicht geliefert.

30

Ref. No	Add-ress	New Parts	Parts No.	Description	Desti-nation	Re-marks
C519			CE04KW1H010M	ELECTRO	1.0UF	50WV
C521			CE04KW1E470M	ELECTRO	47UF	25WV
C522			CE04KW1A471M	ELECTRO	470UF	10WV
C523			CE04KW1A101M	ELECTRO	100UF	10WV
C524			CE04KW1A101M	ELECTRO	100UF	10WV
C525-527			CE04KW1A101M	ELECTRO	100UF	10WV
C535,536			CK73GB1H103K	CHIP C	0.010UF	K
C539			CE04KW1A471M	ELECTRO	470UF	10WV
C541			CK73GB1H103K	CHIP C	0.010UF	K
C544			CE04KW1H100M	ELECTRO	10UF	50WV
C601-610			CC73GCH1H101J	CHIP C	100PF	J
C611,612			CC73GCH1H101J	CHIP C	100PF	J
C613-616			CC73GCH1H101J	CHIP C	100PF	J
C617-619			CK73GF1E104Z	CHIP C	0.10UF	Z
C620			CK73GF1E104Z	CHIP C	0.10UF	Z
C621			CK73GF1E104Z	CHIP C	0.10UF	Z
C622			CE04KW1A471M	ELECTRO	470UF	10WV
C623			CK73GF1E104Z	CHIP C	0.10UF	Z
C624			CE04KW1A101M	ELECTRO	100UF	10WV
C625			CK73GF1E104Z	CHIP C	0.10UF	Z
C626			CE04KW1A471M	ELECTRO	470UF	10WV
C627			CK73GF1E104Z	CHIP C	0.10UF	Z
C628			CE04KW1A101M	ELECTRO	100UF	10WV
C629			CK73GF1E104Z	CHIP C	0.10UF	Z
C630			CE04KW1A101M	ELECTRO	100UF	10WV
C631			CK73GF1E104Z	CHIP C	0.10UF	Z
C632			CE04KW1A101M	ELECTRO	100UF	10WV
C633			CK73GF1E104Z	CHIP C	0.10UF	Z
C634			CE04KW1A101M	ELECTRO	100UF	10WV
C635			CK73GF1E104Z	CHIP C	0.10UF	Z
C636			CE04KW1A471M	ELECTRO	470UF	10WV
C637			CK73GF1E104Z	CHIP C	0.10UF	Z
C638,639			CK73GF1A105Z	CHIP C	1.0UF	Z
C640			CE04KW1A101M	ELECTRO	100UF	10WV
C641			CE04KW1A101M	ELECTRO	100UF	10WV
C642			CE04KW1H010M	ELECTRO	1.0UF	50WV
C643			CK73GB1H103K	CHIP C	0.010UF	K
C644			CK73GF1E104Z	CHIP C	0.10UF	Z
C645			CE04KW1H100M	ELECTRO	10UF	50WV
C646			CK73GF1H223Z	CHIP C	0.022UF	Z
C647			CK73GB1H103K	CHIP C	0.010UF	K
C648			CK73GF1E104Z	CHIP C	0.10UF	Z
C649,650			CE04KW1E470M	ELECTRO	47UF	25WV
C651,652			CE04KW1A221M	ELECTRO	220UF	10WV
C653			CE04KW1H100M	ELECTRO	10UF	50WV
C654			CK73GB1H182K	CHIP C	1800PF	K
C655			CC73GCH1H102J	CHIP C	1000PF	J
C656			CE04KW1H220M	ELECTRO	22UF	50WV
C657			CE04KW1A221M	ELECTRO	220UF	10WV
C658			CK73GF1A105Z	CHIP C	1.0UF	Z
C659			CK73GB1H103K	CHIP C	0.010UF	K
C670			CK73GF1E104Z	CHIP C	0.10UF	Z
C671			CE04KW1H100M	ELECTRO	10UF	50WV
C672			CE04KW1E470M	ELECTRO	47UF	25WV
C701-709			CC73GCH1H470J	CHIP C	47PF	J

L : Scandinavia K : USA P : Canada R : Mexico C : China I : Malaysia
 Y : PX(Far East,Hawaii) T : England E : Europe G : Germany V : China(Shanghai)
 Y : AAFES(Europe) X : Australia Q : Russia H : Korea M : Other Areas Δ indicates safety critical components.

* New Parts

Parts without **Parts No.** are not supplied.
Les articles non mentionnés dans le **Parts No.** ne sont pas fournis.
Teile ohne **Parts No.** werden nicht geliefert.

31

Ref. No	Add-ress	New Parts	Parts No.	Description	Desti-nation	Re-marks
C701-709			CC73GCH1H470J	CHIP C 47PF	J	KP1E1
C701-709			CC73GCH1H470J	CHIP C 47PF	J	Y1M1X1
C710-715			CE04KW1A101M	ELECTRO 100UF	10WV	E2V
C710-715			CE04KW1A101M	ELECTRO 100UF	10WV	KP1E1
C710-715			CE04KW1A101M	ELECTRO 100UF	10WV	Y1M1X1
C716-718			CE04KW1A471M	ELECTRO 470UF	10WV	E2V
C716-718			CE04KW1A471M	ELECTRO 470UF	10WV	KP1E1
C716-718			CE04KW1A471M	ELECTRO 470UF	10WV	Y1M1X1
C719-721			CC73GCH1H102J	CHIP C 1000PF	J	E2V
C719-721			CC73GCH1H102J	CHIP C 1000PF	J	KP1E1
C719-721			CC73GCH1H102J	CHIP C 1000PF	J	Y1M1X1
C851			CE04KW1E470M	ELECTRO 47UF	25WV	E2V
C851			CE04KW1E470M	ELECTRO 47UF	25WV	KP1E1
C851			CE04KW1E470M	ELECTRO 47UF	25WV	Y1M1X1
C852			CE04KW1H100M	ELECTRO 10UF	50WV	E2V
C852			CE04KW1H100M	ELECTRO 10UF	50WV	Y1M1X1
C853,854			CF92FV1H105J	MF-C 1.0UF	J	E2V
C853,854			CF92FV1H105J	MF-C 1.0UF	J	KP1E1
C853,854			CF92FV1H105J	MF-C 1.0UF	J	Y1M1X1
C859			CK73GF1E104Z	CHIP C 0.10UF	Z	E2V
C859			CK73GF1E104Z	CHIP C 0.10UF	Z	KP1E1
C859			CK73GF1E104Z	CHIP C 0.10UF	Z	Y1M1X1
C901-903			CE04KW1H010M	ELECTRO 1.0UF	50WV	KP1K1
C901-903			CE04KW1H010M	ELECTRO 1.0UF	50WV	P2
C904			CE04KW1A221M	ELECTRO 220UF	10WV	KP1K1
C904			CE04KW1A221M	ELECTRO 220UF	10WV	P2
C905			CE04KW1H010M	ELECTRO 1.0UF	50WV	KP1K1
C905			CE04KW1H010M	ELECTRO 1.0UF	50WV	P2
C906-909			CC73GCH1H101J	CHIP C 100PF	J	KP1K1
C906-909			CC73GCH1H101J	CHIP C 100PF	J	P2
CN1			E40-3257-05	PIN ASSY		
CN2			E40-3256-05	PIN ASSY		
CN3			E40-4297-05	FLAT CABLE CONNECTOR		
CN4			E40-9849-05	PIN ASSY		
CN5,6			E40-9853-05	PIN ASSY		
CN7			E40-9840-05	PIN ASSY		
CN8			E40-9840-05	PIN ASSY		E2V
CN8			E40-9840-05	PIN ASSY		KP1E1
CN8			E40-9840-05	PIN ASSY		Y1M1X1
CN9		*	E40-9852-05	PIN ASSY		
CN10			E40-9853-05	PIN ASSY		
CN11,12		*	E40-9852-05	PIN ASSY		
CN13			E40-8258-05	FLAT CABLE CONNECTOR		
CN14			E40-8255-05	FLAT CABLE CONNECTOR		
CN15			E40-9849-05	PIN ASSY		K1P2
CN16			E40-4296-05	FLAT CABLE CONNECTOR		KP1K1
CN16			E40-4296-05	FLAT CABLE CONNECTOR		P2
CN501			E40-9836-05	SOCKET FOR PIN ASSY		
CN601		*	E40-9835-05	SOCKET FOR PIN ASSY		
CN701			E40-9823-05	SOCKET FOR PIN ASSY		E2V
CN701			E40-9823-05	SOCKET FOR PIN ASSY		KP1E1
J501			E63-1021-05	PIN JACK		Y1M1X1

* New Parts

Parts without **Parts No.** are not supplied.
Les articles non mentionnés dans le **Parts No.** ne sont pas fournis.
Teile ohne **Parts No.** werden nicht geliefert.

32

Ref. No	Add-ress	New Parts	Parts No.	Description	Desti-nation	Re-marks
J501			E63-1021-05	PIN JACK		KP1E1
J501			E63-1021-05	PIN JACK		Y1M1X1
J501			E63-1125-05	PIN JACK		K1P2
J502			E63-1125-05	PIN JACK		K1P2
J503			E63-1020-05	PIN JACK		E2V
J503			E63-1020-05	PIN JACK		KP1E1
J503			E63-1020-05	PIN JACK		Y1M1X1
J503			E63-1123-05	PIN JACK		K1P2
J504			E63-1020-05	PIN JACK		E2V
J504			E63-1020-05	PIN JACK		KP1E1
J504			E63-1020-05	PIN JACK		Y1M1X1
J601			E56-0029-05	CYLINDRICAL RECEPTACLE		E2
J601			E56-0029-05	CYLINDRICAL RECEPTACLE		KP1E1
J601			E56-0029-05	CYLINDRICAL RECEPTACLE		Y1M1X1
J601			E56-0029-05	CYLINDRICAL RECEPTACLE		K1P2
J602			E56-0030-05	CYLINDRICAL RECEPTACLE		K1P2
J603			E56-0027-05	CYLINDRICAL RECEPTACLE		E2V
J603			E56-0027-05	CYLINDRICAL RECEPTACLE		KP1E1
J603			E56-0027-05	CYLINDRICAL RECEPTACLE		Y1M1X1
J603			E56-0028-05	CYLINDRICAL RECEPTACLE		K1P2
J604			E56-0027-05	CYLINDRICAL RECEPTACLE		E2V
J604			E56-0027-05	CYLINDRICAL RECEPTACLE		KP1E1
J604			E56-0027-05	CYLINDRICAL RECEPTACLE		Y1M1X1
J701-703		*	E63-1175-05	PIN JACK		E2V
J701-703		*	E63-1175-05	PIN JACK		KP1E1
J701-703		*	E63-1175-05	PIN JACK		Y1M1X1
J901		*	E58-0033-05	RECTANGULAR RECEPTACLE		KP1K1
J901		*	E58-0033-05	RECTANGULAR RECEPTACLE		P2
Δ F5 -7			F06-1022-05	FUSE (SEMKO) (250V T1AL)		E1Y1M1
Δ F5 -7			F06-1022-05	FUSE (SEMKO) (250V T1AL)		X1E2
Δ F5 -7			F50-0067-05	FUSE(5X20)		KP1K1
Δ F5 -7			F50-0067-05	FUSE(5X20)		P2
Δ F5 -7			F50-0108-05	FUSE(5X20)		V
Δ F8			F05-3121-05	FUSE (SEMKO) (250V T3.15AL)		E1Y1M1
Δ F8			F05-3121-05	FUSE (SEMKO) (250V T3.15AL)		X1E2
Δ F8			F50-0072-05	FUSE(5X20)		KP1K1
Δ F8			F50-0072-05	FUSE(5X20)		P2
Δ F8			F50-0111-05	FUSE(5X20)		V
CN22-29			J13-0075-05	FUSE CLIP		
L1 -9			L92-0140-05	CHIP FERRITE		
L10			L92-0140-05	CHIP FERRITE		Y1M1V
L11 -13			L92-0140-05	CHIP FERRITE		
L601			L76-0018-05	DELAY LINE		K1P2
X1			L78-0615-05	RESONATOR (12.5MHZ)		
X2			L78-0674-05	RESONATOR (3.64MHZ)		
X3			L77-2002-05	CRYSTAL RESONATOR(4.332MHZ)		E1E2
Δ R1			RD14NB2E100J	RD 10 J 1/4W		
R2			RK73GB1J102J	CHIP R 1.0K J 1/16W		
R3			RD14NB2E2R2J	RD 2.2 J 1/4W		
Δ R4			RK73GB1J102J	CHIP R 1.0K J 1/16W		
R5			RK73GB1J221J	CHIP R 220 J 1/16W		
R6			RK73GB1J104J	CHIP R 100K J 1/16W		
R7			RK73GB1J102J	CHIP R 1.0K J 1/16W		

PARTS LIST

KRF-X7775D/X7775D-S/VR-5080/5090

L : Scandinavia K : USA P : Canada R : Mexico C : China I : Malaysia
Y : PX(Far East,Hawaii) T : England E : Europe G : Germany V : China(Shanghai)
Y : AAFES(Europe) X : Australia Q : Russia H : Korea M : Other Areas Δ indicates safety critical components .

L : Scandinavia K : USA P : Canada R : Mexico C : China I : Malaysia
Y : PX(Far East,Hawaii) T : England E : Europe G : Germany V : China(Shanghai)
Y : AAFES(Europe) X : Australia Q : Russia H : Korea M : Other Areas Δ indicates safety critical components .

* New Parts

Parts without **Parts No.** are not supplied.Les articles non mentionnés dans le **Parts No.** ne sont pas fournis.Teile ohne **Parts No.** werden nicht geliefert.

33

Ref. No	Address	New Parts	Parts No.	Description	Destination	Remarks
R8			RK73GB1J103J	CHIP R	10K	J 1/16W
R9			RK73GB1J102J	CHIP R	1.0K	J 1/16W
R10			RK73GB1J103J	CHIP R	10K	J 1/16W
R11			RK73GB1J101J	CHIP R	100	J 1/16W
R12			RK73GB1J105J	CHIP R	1.0M	J 1/16W
R13 ,14			RK73GB1J331J	CHIP R	330	J 1/16W
R15 -18			RK73GB1J104J	CHIP R	100K	J 1/16W
R19			RK73GB1J105J	CHIP R	1.0M	J 1/16W
R21 ,22			RK73GB1J332J	CHIP R	3.3K	J 1/16W
R23 ,24			RK73GB1J103J	CHIP R	10K	J 1/16W
R35			RK73GB1J473J	CHIP R	47K	J 1/16W
R41 ,42			RK73GB1J103J	CHIP R	10K	J 1/16W
R51 ,52			RK73GB1J473J	CHIP R	47K	J 1/16W
R53 ,54			RK73GB1J472J	CHIP R	4.7K	J 1/16W
R56 ,57			RK73GB1J472J	CHIP R	4.7K	J 1/16W
R64			RK73GB1J473J	CHIP R	47K	J 1/16W
R69			RK73GB1J473J	CHIP R	47K	J 1/16W
R70 ,71			RK73GB1J332J	CHIP R	3.3K	J 1/16W
R72 ,73			RK73GB1J102J	CHIP R	1.0K	J 1/16W
R74 ,75			RK73GB1J103J	CHIP R	10K	J 1/16W
R76 ,77			RK73GB1J102J	CHIP R	1.0K	J 1/16W
R76 ,77			RK73GB1J102J	CHIP R	1.0K	J 1/16W
R78 ,79			RK73GB1J104J	CHIP R	100K	J 1/16W
R80 -87			RK73GB1J473J	CHIP R	47K	J 1/16W
R88			RK73GB1J2R2J	CHIP R	2.2	J 1/16W
R89			RK73GB1J101J	CHIP R	100	J 1/16W
R90			RK73GB1J104J	CHIP R	100K	J 1/16W
R91 -96			RK73GB1J102J	CHIP R	1.0K	J 1/16W
R97			RK73GB1J2R2J	CHIP R	2.2	J 1/16W
R98			RD14NB2E471J	RD	470	J 1/4W
R98			RD14NB2E471J	RD	470	J 1/4W
R99			RK73GB1J101J	CHIP R	100	J 1/16W
R100			RK73GB1J102J	CHIP R	1.0K	J 1/16W
R100			RK73GB1J102J	CHIP R	1.0K	J 1/16W
R101			RK73GB1J103J	CHIP R	10K	J 1/16W
R101			RK73GB1J103J	CHIP R	10K	J 1/16W
R101			RK73GB1J332J	CHIP R	3.3K	J 1/16W
R102			RK73GB1J103J	CHIP R	10K	J 1/16W
R102			RK73GB1J182J	CHIP R	1.8K	J 1/16W
R102			RK73GB1J822J	CHIP R	8.2K	J 1/16W
R103			RK73GB1J103J	CHIP R	10K	J 1/16W
R103			RK73GB1J103J	CHIP R	10K	J 1/16W
R103			RK73GB1J222J	CHIP R	2.2K	J 1/16W
R103			RK73GB1J622J	CHIP R	6.2K	J 1/16W
R103			RK73GB1J622J	CHIP R	6.2K	J 1/16W
R104			RK73GB1J472J	CHIP R	4.7K	J 1/16W
R104			RK73GB1J472J	CHIP R	4.7K	J 1/16W
R104			RK73GB1J822J	CHIP R	8.2K	J 1/16W
R105			RK73GB1J473J	CHIP R	47K	J 1/16W
R107			RK73GB1J272J	CHIP R	2.7K	J 1/16W
R108			RK73GB1J102J	CHIP R	1.0K	J 1/16W
R109			RD14NB2E101J	RD	100	J 1/4W
R110			RD14NB2E560J	RD	56	J 1/4W
R111,112			RD14NB2E4R7J	RD	4.7	J 1/4W
R113			RK73GB1J332J	CHIP R	3.3K	J 1/16W

L : Scandinavia

K : USA

P : Canada

R : Mexico

C : China

I : Malaysia

Y : PX(Far East,Hawaii)

T : England

E : Europe

G : Germany

V : China(Shanghai)

Y : AAFES(Europe)

X : Australia

Q : Russia

H : Korea

M : Other Areas

⚠ indicates safety critical components .

* New Parts

Parts without **Parts No.** are not supplied.Les articles non mentionnés dans le **Parts No.** ne sont pas fournis.Teile ohne **Parts No.** werden nicht geliefert.

34

Ref. No	Address	New Parts	Parts No.	Description	Destination	Remarks
R114			RK73GB1J272J	CHIP R	2.7K	J 1/16W
R115			RD14NB2E122J	RD	1.2K	J 1/4W
R116			RK73GB1J683J	CHIP R	68K	J 1/16W
R117			RK73GB1J102J	CHIP R	1.0K	J 1/16W
R118			RK73GB1J683J	CHIP R	68K	J 1/16W
R119			RK73GB1J332J	CHIP R	3.3K	J 1/16W
R120			RK73GB1J683J	CHIP R	68K	J 1/16W
R121			RK73GB1J332J	CHIP R	3.3K	J 1/16W
R122			RK73GB1J683J	CHIP R	68K	J 1/16W
R123			RK73GB1J332J	CHIP R	3.3K	J 1/16W
R124			RK73GB1J683J	CHIP R	68K	J 1/16W
R125			RK73GB1J272J	CHIP R	2.7K	J 1/16W
R126			RK73GB1J103J	CHIP R	10K	J 1/16W
R127			RD14NB2E100J	RD	10	J 1/4W
R128			RS14KB3D4R7J	FL-PROOF RS	4.7	J 2W
R130-132			RK73GB1J101J	CHIP R	100	J 1/16W
R133			RK73GB1J332J	CHIP R	3.3K	J 1/16W
R134			RK73GB1J473J	CHIP R	47K	J 1/16W
R135,136			RK73GB1J101J	CHIP R	100	J 1/16W
R137,138			RK73GB1J332J	CHIP R	3.3K	J 1/16W
R139			RK73GB1J101J	CHIP R	100	J 1/16W
R140,141			RK73GB1J332J	CHIP R	3.3K	J 1/16W
R142			RK73GB1J101J	CHIP R	100	J 1/16W
R150-161			RK73GB1J101J	CHIP R	100	J 1/16W
R170			RK73GB1J103J	CHIP R	10K	J 1/16W
R171-173			RK73GB1J101J	CHIP R	100	J 1/16W
R171-173			RK73GB1J101J	CHIP R	100	J 1/16W
R174,175			RK73GB1J101J	CHIP R	100	J 1/16W
R176-178			RK73GB1J101J	CHIP R	100	J 1/16W
R179,180			RK73GB1J101J	CHIP R	100	J 1/16W
R181-192			RK73GB1J102J	CHIP R	1.0K	J 1/16W
R197			RD14NB2E560J	RD	56	J 1/4W
R198			RK73GB1J472J	CHIP R	4.7K	J 1/16W
R199			RK73GB1J101J	CHIP R	100	J 1/16W
R200			RK73GB1J221J	CHIP R	220	J 1/16W
R201			RK73GB1J101J	CHIP R	100	J 1/16W
R202,203			RK73GB1J103J	CHIP R	10K	J 1/16W
R204-208			RK73GB1J101J	CHIP R	100	J 1/16W
R209			RK73GB1J105J	CHIP R	1.0M	J 1/16W
R212,213			RK73GB1J102J	CHIP R	1.0K	J 1/16W
R212,213			RK73GB1J102J	CHIP R	1.0K	J 1/16W
R214,215			RK73GB1J104J	CHIP R	100K	J 1/16W
R216			RK73GB1J105J	CHIP R	1.0M	J 1/16W
R223,224			RK73GB1J103J	CHIP R	10K	J 1/16W
R229			RK73GB1J101J	CHIP R	100	J 1/16W
R230			RK73GB1J220J	CHIP R	22	J 1/16W
R231,232			RK73GB1J102J	CHIP R	1.0K	J 1/16W
R233			RK73GB1J103J	CHIP R	10K	J 1/16W
R234			RK73GB1J221J	CHIP R	220	J 1/16W
R235,236			RK73GB1J105J	CHIP R	1.0M	J 1/16W
R251-256			RK73GB1J472J	CHIP R	4.7K	J 1/16W
R257			RK73GB1J332J	CHIP R	3.3K	J 1/16W
R258,259			RK73GB1J272J	CHIP R	2.7K	J 1/16W
R264-266			RK73GB1J103J	CHIP R	10K	J 1/16W
R301-303			RK73GB1J391J	CHIP R	390	J 1/16W

L : Scandinavia

K : USA

P : Canada

R : Mexico

C : China

I : Malaysia

Y : PX(Far East,Hawaii)

T : England

E : Europe

G : Germany

V : China(Shanghai)

Y : AAFES(Europe)

X : Australia

Q : Russia

H : Korea

M : Other Areas

⚠ indicates safety critical components .

* New Parts

Parts without **Parts No.** are not supplied.
Les articles non mentionnés dans le **Parts No.** ne sont pas fournis.
Teile ohne **Parts No.** werden nicht geliefert.



Ref. No	Address	New Parts	Parts No.	Description	Destination	Remarks
R304-306			RK73GB1J101J	CHIP R 100	J 1/16W	
R307,308			RK73GB1J222J	CHIP R 2.2K	J 1/16W	
R309			RK73GB1J474J	CHIP R 470K	J 1/16W	
R310			RK73GB1J163J	CHIP R 16K	J 1/16W	
R311			RK73GB1J153J	CHIP R 15K	J 1/16W	
R312			RK73GB1J470J	CHIP R 47	J 1/16W	
R313-315			RK73GB1J2R2J	CHIP R 2.2	J 1/16W	
R316			RK73GB1J103J	CHIP R 10K	J 1/16W	
R317			RK73GB1J472J	CHIP R 4.7K	J 1/16W	
R318			RK73GB1J104J	CHIP R 100K	J 1/16W	
R321,322			RK73GB1J471J	CHIP R 470	J 1/16W	
R324			RK73GB1J471J	CHIP R 470	J 1/16W	
R325			RK73GB1J102J	CHIP R 1.0K	J 1/16W	
R326,327			RK73GB1J2R2J	CHIP R 2.2	J 1/16W	
R329			RK73GB1J102J	CHIP R 1.0K	J 1/16W	
R330			RK73GB1J471J	CHIP R 470	J 1/16W	
R331			RD14NB2E332J	RD 3.3K	J 1/4W	
R332			RK73GB1J221J	CHIP R 220	J 1/16W	
R333			RD14NB2E2R2J	RD 2.2	J 1/4W	
R334			RK73GB1J101J	CHIP R 100	J 1/16W	
R341-346			RD14NB2E1R0J	RD 1	J 1/4W	
R350-361			RK73GB1J473J	CHIP R 47K	J 1/16W	
R370-372			RK73GB1J4R7J	CHIP R 4.7	J 1/16W	
R400			RK73GB1J473J	CHIP R 47K	J 1/16W	
R401,402			RK73GB1J101J	CHIP R 100	J 1/16W	
R403			RK73GB1J102J	CHIP R 1.0K	J 1/16W	
R410,411			RD14NB2E4R7J	RD 4.7	J 1/4W	
R501			RK73GB1J104J	CHIP R 100K	J 1/16W	
R502			RK73FB2A750J	CHIP R 75	J 1/10W	
R503			RK73GB1J104J	CHIP R 100K	J 1/16W	
R504,505			RK73FB2A750J	CHIP R 75	J 1/10W	
R506			RK73FB2A750J	CHIP R 75	J 1/10W	
R507			RK73FB2A750J	CHIP R 75	J 1/10W	
R508			RK73GB1J104J	CHIP R 100K	J 1/16W	
R509			RK73FB2A680J	CHIP R 68	J 1/10W	
R510			RK73GB1J104J	CHIP R 100K	J 1/16W	
R511			RK73FB2A680J	CHIP R 68	J 1/10W	
R512			RK73GB1J104J	CHIP R 100K	J 1/16W	
R513			RK73FB2A680J	CHIP R 68	J 1/10W	
R514,515			RK73GB1J103J	CHIP R 10K	J 1/16W	
R516			RD14NB2E4R7J	RD 4.7	J 1/4W	
R529,530			RK73GB1J473J	CHIP R 47K	J 1/16W	
R531-533			RK73GB1J1R0J	CHIP R 1	J 1/16W	
R536			RK73FB2A680J	CHIP R 68	J 1/10W	
R539			RK73GB1J103J	CHIP R 10K	J 1/16W	
R540			RK73GB1J473J	CHIP R 47K	J 1/16W	
R541			RK73GB1J104J	CHIP R 100K	J 1/16W	
R542			RK73GB1J102J	CHIP R 1.0K	J 1/16W	
R543			RK73GB1J473J	CHIP R 47K	J 1/16W	
R551-553			RK73GB1J101J	CHIP R 100	J 1/16W	
R554			RK73GB1J101J	CHIP R 100	J 1/16W	
R555,556			RK73GB1J101J	CHIP R 100	J 1/16W	
R557			RK73GB1J101J	CHIP R 100	J 1/16W	
R558-560			RK73GB1J101J	CHIP R 100	J 1/16W	
R563			RK73GB1J104J	CHIP R 100K	J 1/16W	

L : Scandinavia K : USA P : Canada R : Mexico C : China I : Malaysia
Y : PX(Far East,Hawaii) T : England E : Europe G : Germany V : China(Shanghai)
Y : AAFES(Europe) X : Australia Q : Russia H : Korea M : Other Areas Δ indicates safety critical components.

* New Parts

Parts without **Parts No.** are not supplied.
Les articles non mentionnés dans le **Parts No.** ne sont pas fournis.
Teile ohne **Parts No.** werden nicht geliefert.



Ref. No	Address	New Parts	Parts No.	Description	Destination	Remarks
R601,602			RK73GB1J104J	CHIP R 100K	J 1/16W	
R603			RK73FB2A750J	CHIP R 75	J 1/10W	
R604,605			RK73GB1J104J	CHIP R 100K	J 1/16W	
R606,607			RK73FB2A750J	CHIP R 75	J 1/10W	
R608			RK73FB2A750J	CHIP R 75	J 1/10W	K1P2
R609			RK73FB2A750J	CHIP R 75	J 1/10W	
R610,611			RK73GB1J104J	CHIP R 100K	J 1/16W	
R612-614			RK73FB2A750J	CHIP R 75	J 1/10W	
R615			RK73FB2A750J	CHIP R 75	J 1/10W	
R616			RK73FB2A750J	CHIP R 75	J 1/10W	K1P2
R617			RK73GB1J104J	CHIP R 100K	J 1/16W	
R618,619			RK73FB2A680J	CHIP R 68	J 1/10W	
R620,621			RK73GB1J104J	CHIP R 100K	J 1/16W	
R622,623			RK73FB2A680J	CHIP R 68	J 1/10W	
R624			RK73GB1J104J	CHIP R 100K	J 1/16W	
R625,626			RK73FB2A680J	CHIP R 68	J 1/10W	
R627-630			RK73GB1J103J	CHIP R 10K	J 1/16W	
R631,632			RK73GB1J473J	CHIP R 47K	J 1/16W	
R633,634			RK73GB1J1R0J	CHIP R 1	J 1/16W	KP1E1
R635			RK73GB1J1R0J	CHIP R 1	J 1/16W	K1P2
R636			RK73GB1J103J	CHIP R 10K	J 1/16W	K1P2
R637			RK73GB1J273J	CHIP R 27K	J 1/16W	K1P2
R638			RK73GB1J332J	CHIP R 3.3K	J 1/16W	K1P2
R639,640			RK73GB1J102J	CHIP R 1.0K	J 1/16W	
R641,642			RK73GB1J1R0J	CHIP R 1	J 1/16W	
R643,644			RK73GB1J151J	CHIP R 150	J 1/16W	K1P2
R645			RK73GB1J473J	CHIP R 47K	J 1/16W	
R647			RK73GB1J103J	CHIP R 10K	J 1/16W	K1P2
R648			RK73GB1J223J	CHIP R 22K	J 1/16W	K1P2
R649,650			RK73GB1J103J	CHIP R 10K	J 1/16W	K1P2
R651			RK73GB1J562J	CHIP R 5.6K	J 1/16W	K1P2
R652			RK73GB1J104J	CHIP R 100K	J 1/16W	K1P2
R653			RK73GB1J101J	CHIP R 100	J 1/16W	K1P2
R654			RK73GB1J474J	CHIP R 470K	J 1/16W	K1P2
R655			RK73GB1J103J	CHIP R 10K	J 1/16W	K1P2
R659-662			RK73GB1J911J	CHIP R 910	J 1/16W	K1P2
R663			RK73GB1J183J	CHIP R 18K	J 1/16W	K1P2
R665			RK73GB1J103J	CHIP R 10K	J 1/16W	K1P2
R666			RK73GB1J273J	CHIP R 27K	J 1/16W	K1P2
R667			RK73GB1J332J	CHIP R 3.3K	J 1/16W	K1P2
R668			RK73GB1J104J	CHIP R 100K	J 1/16W	K1P2
R669,670			RK73GB1J471J	CHIP R 470	J 1/16W	K1P2
R674			RK73GB1J1R0J	CHIP R 1	J 1/16W	
R687			RK73GB1J1R0J	CHIP R 1	J 1/16W	
R701-706			RK73FB2A750J	CHIP R 75	J 1/10W	E2V
R701-706			RK73FB2A750J	CHIP R 75	J 1/10W	KP1E1
R701-706			RK73FB2A750J	CHIP R 75	J 1/10W	Y1M1X1
R707-709			RK73GB1J104J	CHIP R 100K	J 1/16W	E2V
R707-709			RK73GB1J104J	CHIP R 100K	J 1/16W	KP1E1
R707-709			RK73GB1J104J	CHIP R 100K	J 1/16W	Y1M1X1
R710-712			RK73FB2A390J	CHIP R 39	J 1/10W	E2V
R710-712			RK73FB2A390J	CHIP R 39	J 1/10W	KP1E1
R710-712			RK73FB2A390J	CHIP R 39	J 1/10W	Y1M1X1
R713-715			RK73GB1J1R0J	CHIP R 1	J 1/16W	E2V
R713-715			RK73GB1J1R0J	CHIP R 1	J 1/16W	KP1E1

L : Scandinavia K : USA P : Canada R : Mexico C : China I : Malaysia
Y : PX(Far East,Hawaii) T : England E : Europe G : Germany V : China(Shanghai)
Y : AAFES(Europe) X : Australia Q : Russia H : Korea M : Other Areas Δ indicates safety critical components.

PARTS LIST

KRF-X7775D/X7775D-S/VR-5080/5090

* New Parts

Parts without **Parts No.** are not supplied.Les articles non mentionnés dans le **Parts No.** ne sont pas fournis.Teile ohne **Parts No.** werden nicht geliefert.

37

Ref. No	Address	New Parts	Parts No.	Description	Destination	Remarks
R713-715			RK73GB1J1R0J	CHIP R 1 J 1/16W	Y1M1X1	
R768-770			RK73GB1J102J	CHIP R 1.0K J 1/16W	E2V	
R768-770			RK73GB1J102J	CHIP R 1.0K J 1/16W	KP1E1	
R768-770			RK73GB1J102J	CHIP R 1.0K J 1/16W	Y1M1X1	
R780			RK73GB1J473J	CHIP R 47K J 1/16W	E2	
R780			RK73GB1J473J	CHIP R 47K J 1/16W	KP1E1	
R780			RK73GB1J473J	CHIP R 47K J 1/16W	Y1M1X1	
R784-786			RK73GB1J104J	CHIP R 100K J 1/16W	E2V	
R784-786			RK73GB1J104J	CHIP R 100K J 1/16W	KP1E1	
R784-786			RK73GB1J104J	CHIP R 100K J 1/16W	Y1M1X1	
R805-810			RK73GB1J101J	CHIP R 100 J 1/16W	E2V	
R805-810			RK73GB1J101J	CHIP R 100 J 1/16W	KP1E1	
R805-810			RK73GB1J101J	CHIP R 100 J 1/16W	Y1M1X1	
R830			RK73GB1J1R0J	CHIP R 1 J 1/16W	E2V	
R840			RK73GB1J1R0J	CHIP R 1 J 1/16W	E2V	
R840			RK73GB1J1R0J	CHIP R 1 J 1/16W	KP1E1	
R840			RK73GB1J1R0J	CHIP R 1 J 1/16W	Y1M1X1	
R851			RK73GB1J1R0J	CHIP R 1 J 1/16W	E2V	
R851			RK73GB1J1R0J	CHIP R 1 J 1/16W	KP1E1	
R851			RK73GB1J1R0J	CHIP R 1 J 1/16W	Y1M1X1	
R901-908			RK73GB1J101J	CHIP R 100 J 1/16W	KP1K1	
R901-908			RK73GB1J101J	CHIP R 100 J 1/16W	P2	
R909			RK73GB1J220J	CHIP R 22 J 1/16W	KP1K1	
R909			RK73GB1J220J	CHIP R 22 J 1/16W	P2	
W501,502			R92-1963-05	JUMPER WIRE (RESISTOR TYPE)		
D1			U1BC44	DIODE		
D2			MA111	DIODE		
D3			U1BC44	DIODE		
D4 -6			MA111	DIODE		
D7			DAN202U	DIODE		
D7			1SS301	DIODE		
D8			DAP202U	DIODE		
D8			1SS300	DIODE		
D9			DAN202U	DIODE		
D9			1SS301	DIODE		
D10			DAP202U	DIODE		
D10			1SS300	DIODE		
D11 -23			MA111	DIODE		
D27 -29			U1BC44	DIODE		
D30			UDZS5.6B	ZENER DIODE		
D30			UDZ5.6B	ZENER DIODE		
D35			DAN202U	DIODE		
D35			1SS301	DIODE		
D36 ,37			MA111	DIODE		
D38			DAN202U	DIODE		
D38			1SS301	DIODE		
D41 ,42			DAP202U	DIODE		
D41 ,42			1SS300	DIODE		
D43 -45			MA111	DIODE		
D51			S1ZB20(4072)	DIODE		
D52			UDZS8.2B	ZENER DIODE		
D52			UDZ8.2B	ZENER DIODE		
D53		*	UDZS7.5B	ZENER DIODE		
D53			UDZ7.5B	ZENER DIODE		
D61			D4SBL20UF03	DIODE		

L : Scandinavia

K : USA

P : Canada

R : Mexico

C : China

I : Malaysia

Y : PX(Far East,Hawaii)

T : England

E : Europe

G : Germany

V : China(Shanghai)

Y : AAFES(Europe)

X : Australia

Q : Russia

H : Korea

M : Other Areas

⚠ indicates safety critical components .

* New Parts

Parts without **Parts No.** are not supplied.Les articles non mentionnés dans le **Parts No.** ne sont pas fournis.Teile ohne **Parts No.** werden nicht geliefert.

38

Ref. No	Address	New Parts	Parts No.	Description	Destination	Remarks
D62			UDZS6.2B	ZENER DIODE		
D62			UDZ6.2B	ZENER DIODE		
D63			MA111	DIODE		
D71			KBP02ML-6127	DIODE		
D72			UDZ16B	ZENER DIODE		
D80 ,81			DA204U	DIODE		
D80 ,81			1SS302	DIODE		
D501			DAN202U	DIODE		
D501			1SS301	DIODE		
D502			DAP202U	DIODE		
D502			1SS300	DIODE		
D503,504			MA111	DIODE		
D601			DAN202U	DIODE		
D601			1SS301	DIODE		
D602			DAP202U	DIODE		
D602			1SS300	DIODE		
D603,604			MA111	DIODE		
D605			DA204U	DIODE		K1P2
D605			1SS302	DIODE		K1P2
IC1			TA78057S	ANALOGUE IC		
IC2			S-80740AL-A4	IC(VOLTAGE DETECTOR)		
IC2		*	S-80840ALUP	MOS-IC		
IC3		*	UPD784217A516	MI-COM IC		
IC4			TC74HCT7007AF	MOS-IC		
IC5			TC74HC164AF	IC(SHIFT REGISTER)		
IC6			UPD17215GT-737	MI-COM IC		
IC7			LC72723M	MOS-IC		E1E2
IC501		*	MM1140XFF	ANALOGUE IC		
IC502			BA7611AF	ANALOGUE IC		
IC503			BA7623F	ANALOGUE IC		
IC504			BA7649AF	ANALOGUE IC		
IC507		*	MM1508	ANALOGUE IC		
IC601,602		*	MM1140XFF	ANALOGUE IC		
IC603			BA7611AF	ANALOGUE IC		
IC604			BA7612F	ANALOGUE IC		
IC605,606			BA7623F	ANALOGUE IC		
IC607			NJM4565M	ANALOGUE IC		K1P2
IC608			UPC29M05HB	ANALOGUE IC		
IC701			BA7613F	ANALOGUE IC		E2V
IC701			BA7613F	ANALOGUE IC		KP1E1
IC701			BA7613F	ANALOGUE IC		Y1M1X1
IC702,703			BA7612F	ANALOGUE IC		E2V
IC702,703			BA7612F	ANALOGUE IC		KP1E1
IC702,703			BA7612F	ANALOGUE IC		Y1M1X1
IC708			UPC29M05HB	ANALOGUE IC		E2V
IC708			UPC29M05HB	ANALOGUE IC		KP1E1
IC708			UPC29M05HB	ANALOGUE IC		Y1M1X1
IC901			MAX232NS	MOS-IC		KP1K1
IC901			MAX232NS	MOS-IC		P2
Q1			2SC4081(R,S)	TRANSISTOR		
Q1			2SC4116(Y,GR)	TRANSISTOR		
Q2			DTC124EUA	DIGITAL TRANSISTOR		Y1M1V
Q2			UN5212	DIGITAL TRANSISTOR		Y1M1V
Q3			DTA113ZUA	DIGITAL TRANSISTOR		
Q3			UN5119	DIGITAL TRANSISTOR		

L : Scandinavia

K : USA

P : Canada

R : Mexico

C : China

I : Malaysia

Y : PX(Far East,Hawaii)

T : England

E : Europe

G : Germany

V : China(Shanghai)

Y : AAFES(Europe)

X : Australia

Q : Russia

H : Korea

M : Other Areas

⚠ indicates safety critical components .

* New Parts

Parts without **Parts No.** are not supplied.
Les articles non mentionnés dans le **Parts No.** ne sont pas fournis.
Teile ohne **Parts No.** werden nicht geliefert.

39

Ref. No	Address	New Parts	Parts No.	Description	Destination	Remarks
Q4			DTC143TUA	DIGITAL TRANSISTOR		
Q4			UN5216	DIGITAL TRANSISTOR		
Q5			DTA113ZUA	DIGITAL TRANSISTOR		
Q5			UN5119	DIGITAL TRANSISTOR		
Q6			DTC143TUA	DIGITAL TRANSISTOR		
Q6			UN5216	DIGITAL TRANSISTOR		
Q7			DTA113ZUA	DIGITAL TRANSISTOR		
Q7			UN5119	DIGITAL TRANSISTOR		
Q8			DTC143TUA	DIGITAL TRANSISTOR		
Q8			UN5216	DIGITAL TRANSISTOR		
Q9			DTA113ZUA	DIGITAL TRANSISTOR		
Q9			UN5119	DIGITAL TRANSISTOR		
Q10			DTC143TUA	DIGITAL TRANSISTOR		
Q10			UN5216	DIGITAL TRANSISTOR		
Q11			DTA113ZUA	DIGITAL TRANSISTOR		
Q11			UN5119	DIGITAL TRANSISTOR		
Q12			DTC143TUA	DIGITAL TRANSISTOR		
Q12			UN5216	DIGITAL TRANSISTOR		
Q13			DTA113ZUA	DIGITAL TRANSISTOR		
Q13			UN5119	DIGITAL TRANSISTOR		
Q14			DTC143TUA	DIGITAL TRANSISTOR		
Q14			UN5216	DIGITAL TRANSISTOR		
Q15			DTA113ZUA	DIGITAL TRANSISTOR		
Q15			UN5116	DIGITAL TRANSISTOR		
Q16			DTC124EUA	DIGITAL TRANSISTOR		
Q16			UN5212	DIGITAL TRANSISTOR		
Q17			2SC3940A(R,S)	TRANSISTOR		
Q18			DTA143TUA	DIGITAL TRANSISTOR		
Q18			UN5116	DIGITAL TRANSISTOR		
Q19			2SC4213(B)	TRANSISTOR		
Q31 ,32			2SK246(Y,GR)	FET		
△ Q33 ,34			2SB1375	TRANSISTOR		
△ Q35			2SC4081(R,S)	TRANSISTOR		
△ Q35			2SC4116(Y,GR)	TRANSISTOR		
△ Q36			2SA1576A(R,S)	TRANSISTOR		
△ Q36			2SA1586(Y,GR)	TRANSISTOR		
△ Q37			2SC4081(R,S)	TRANSISTOR		
△ Q37			2SC4116(Y,GR)	TRANSISTOR		
△ Q38			2SA1576A(R,S)	TRANSISTOR		
△ Q38			2SA1586(Y,GR)	TRANSISTOR		
△ Q41 ,42			2SB1375	TRANSISTOR		
△ Q43			2SC4081(R,S)	TRANSISTOR		
△ Q43			2SC4116(Y,GR)	TRANSISTOR		
△ Q45			2SB1375	TRANSISTOR		
△ Q46			2SC4081(R,S)	TRANSISTOR		
△ Q46			2SC4116(Y,GR)	TRANSISTOR		
△ Q51			2SD2012	TRANSISTOR		
△ Q52			2SC4081(R,S)	TRANSISTOR		
△ Q52			2SC4116(Y,GR)	TRANSISTOR		
△ Q61			DTC124EUA	DIGITAL TRANSISTOR		
Q61			UN5212	DIGITAL TRANSISTOR		
Q62			DTA143TUA	DIGITAL TRANSISTOR		
Q62			UN5116	DIGITAL TRANSISTOR		
Q501 ,502			2SC4213(B)	TRANSISTOR		
Q504,505			DTA124EUA	DIGITAL TRANSISTOR		

L : Scandinavia K : USA P : Canada R : Mexico C : China I : Malaysia
Y : PX(Far East,Hawaii) T : England E : Europe G : Germany V : China(Shanghai)
Y : AAFES(Europe) X : Australia Q : Russia H : Korea M : Other Areas △ indicates safety critical components .

* New Parts

Parts without **Parts No.** are not supplied.
Les articles non mentionnés dans le **Parts No.** ne sont pas fournis.
Teile ohne **Parts No.** werden nicht geliefert.

40

Ref. No	Address	New Parts	Parts No.	Description	Destination	Remarks
Q504,505			UN5112	DIGITAL TRANSISTOR		
Q506			DTC124EUA	DIGITAL TRANSISTOR		
Q506			UN5212	DIGITAL TRANSISTOR		
Q508,509			2SC4213(B)	TRANSISTOR		
Q601-604			2SC4213(B)	TRANSISTOR		
Q605,606			DTA124EUA	DIGITAL TRANSISTOR		
Q605,606			UN5112	DIGITAL TRANSISTOR		
Q607			DTC124EUA	DIGITAL TRANSISTOR		
Q607			UN5212	DIGITAL TRANSISTOR		
Q608,609			DTA124EUA	DIGITAL TRANSISTOR		K1P2
Q608,609			UN5112	DIGITAL TRANSISTOR		K1P2
Q610,611			DTC124EUA	DIGITAL TRANSISTOR		K1P2
Q610,611			UN5212	DIGITAL TRANSISTOR		K1P2
Q613,614			2SC4213(B)	TRANSISTOR		
Q715-717			2SC4213(B)	TRANSISTOR		E2V
Q715-717			2SC4213(B)	TRANSISTOR		KP1E1
Q715-717			2SC4213(B)	TRANSISTOR		Y1M1X1
DISPLAY UNIT (X25-641/642X-XX)						
D3 -10			B30-2532-05	LED(INFRARED)		
D11			B30-2548-05	LED(GRN5,HI BRT)		KP1K1
D11			B30-2548-05	LED(GRN5,HI BRT)		M1X1E2
D11			B30-2548-05	LED(GRN5,HI BRT)		P2E1Y1
D11			B30-2571-05	LED(GRN5,HI BRT)		V
D12			B30-2430-05	LED(RED)		V
D15 -18			B30-2571-05	LED(RED5,HI BRT)		KP1K1
D15 -18			B30-2573-05	LED(RED5,HI BRT)		M1X1E2
D15 -18			B30-2573-05	LED(RED5,HI BRT)		P2E1Y1
D15 -18			B30-2573-05	LED(RED5,HI BRT)		V
D19 -23			B30-2430-05	LED(RED)		V
D24 ,25			B30-2571-05	LED(RED5,HI BRT)		KP1K1
D24 ,25			B30-2573-05	LED(RED5,HI BRT)		M1X1E2
D24 ,25			B30-2573-05	LED(RED5,HI BRT)		P2E1Y1
D24 ,25			B30-2573-05	LED(RED5,HI BRT)		V
D26			B30-2597-05	LED(RED HI-BRIGHT)		
D30 ,31			B30-2430-05	LED(RED)		
C1 ,2			CE04RW1C101M	ELECTRO	100UF	16WV
C3			CC73GCH1H102J	CHIP C	1000PF	J
C4			CC73GCH1H101J	CHIP C	100PF	J
C5			CE04KW1H100M	ELECTRO	10UF	50WV
C6			CK73GB1H103K	CHIP C	0.010UF	K
C7 -22			CC73GCH1H221J	CHIP C	220PF	J
C23			CE04KW1H100M	ELECTRO	10UF	50WV
C24			CC73GCH1H471J	CHIP C	470PF	J
C25 -27			CC73GCH1H101J	CHIP C	100PF	J
C28			CE04KW1E470M	ELECTRO	47UF	25WV
C31			CE04KW1H101M	ELECTRO	100UF	50WV
C33			CK73GF1E104Z	CHIP C	0.10UF	Z
C40			CQ93FMG1H102J	MYLAR	1000PF	J
C41 -43			CQ93FMG1H472J	MYLAR	4700PF	J
C44 ,45			CC73GCH1H221J	CHIP C	220PF	J
C78 -80			CE04KW1E470M	ELECTRO	47UF	25WV
C81 -85			CE04KW1E470M	ELECTRO	47UF	25WV
C86			CK73GF1E104Z	CHIP C	0.10UF	Z
C88			CC73GCH1H270J	CHIP C	27PF	J

L : Scandinavia K : USA P : Canada R : Mexico C : China I : Malaysia
Y : PX(Far East,Hawaii) T : England E : Europe G : Germany V : China(Shanghai)
Y : AAFES(Europe) X : Australia Q : Russia H : Korea M : Other Areas △ indicates safety critical components .

PARTS LIST

KRF-X7775D/X7775D-S/VR-5080/5090

* New Parts

Parts without **Parts No.** are not supplied.Les articles non mentionnés dans le **Parts No.** ne sont pas fournis.Teile ohne **Parts No.** werden nicht geliefert.

41

Ref. No	Add-ress	New Parts	Parts No.	Description	Desti-nation	Re-marks
C91 -93			CC73GCH1H101J	CHIP C	100PF	J
C94			CK73GF1E104Z	CHIP C	0.10UF	Z
C95 -97			CC73GCH1H101J	CHIP C	100PF	J
C105			CC73GCH1H101J	CHIP C	100PF	J
C165,166			CK73FF1C105Z	CHIP C	1.0UF	Z
C170			CK73GB1H103K	CHIP C	0.010UF	K
C301,302			CE04KW1H220M	ELECTRO	22UF	50WV
C303,304			CC73GCH1H101J	CHIP C	100PF	J
C311,312			CE04KW1H220M	ELECTRO	22UF	50WV
C313,314			CC73GCH1H101J	CHIP C	100PF	J
C321,322			CE04KW1H220M	ELECTRO	22UF	50WV
C323,324			CC73GCH1H101J	CHIP C	100PF	J
C331,332			CE04KW1H220M	ELECTRO	22UF	50WV
C333,334			CC73GCH1H101J	CHIP C	100PF	J
C341,342			CE04KW1H220M	ELECTRO	22UF	50WV
C343,344			CC73GCH1H101J	CHIP C	100PF	J
C380			CC73GCH1H101J	CHIP C	100PF	J
C401,402			CC73GCH1H221J	CHIP C	220PF	J
C404,405			CC73GCH1H221J	CHIP C	220PF	J
C406			CC73GCH1H101J	CHIP C	100PF	J
C406			CC73GCH1H101J	CHIP C	100PF	J
C407			CK73GF1E104Z	CHIP C	0.10UF	Z
C407			CK73GF1E104Z	CHIP C	0.10UF	Z
C407			CK73GF1E104Z	CHIP C	0.10UF	Z
C410			CE04KW1A101M	ELECTRO	100UF	10WV
C410			CE04KW1A101M	ELECTRO	100UF	10WV
C415			CC73GCH1H101J	CHIP C	100PF	J
C415			CC73GCH1H101J	CHIP C	100PF	J
C415			CC73GCH1H101J	CHIP C	100PF	J
C416			CC73GCH1H331J	CHIP C	330PF	J
C416			CC73GCH1H331J	CHIP C	330PF	J
C416			CC73GCH1H331J	CHIP C	330PF	J
C417			CC73GCH1H102J	CHIP C	1000PF	J
C417			CC73GCH1H102J	CHIP C	1000PF	J
C419-421			CC73GCH1H101J	CHIP C	100PF	J
C419-421			CC73GCH1H101J	CHIP C	100PF	J
C419-421			CC73GCH1H101J	CHIP C	100PF	J
C430,431			CK73GF1E104Z	CHIP C	0.10UF	Z
C430,431			CK73GF1E104Z	CHIP C	0.10UF	Z
CN2		*	E40-8794-05	PIN ASSY		
CN4			E40-9823-05	SOCKET FOR PIN ASSY		
CN5		*	E40-8622-05	PIN ASSY		
CN5		*	E40-8622-05	PIN ASSY		
CN101		*	E40-8257-05	FLAT CABLE CONNECTOR		E1Y1M1 X1E2V
CN102			E40-8254-05	FLAT CABLE CONNECTOR		
CN103			E40-8531-05	FLAT CABLE CONNECTOR		KP1K1
CN103			E40-8531-05	FLAT CABLE CONNECTOR		P2
J1		*	E70-0133-15	SCREW TERMINAL BOARD		
J5			E63-1121-05	PIN JACK		
J6			E56-0026-05	CYLINDRICAL RECEPTACLE		
J7			E11-0190-05	PHONE JACK (3P)		
J101		*	E63-1173-05	PIN JACK		E2V
J101		*	E63-1173-05	PIN JACK		KP1E1

L : Scandinavia K : USA P : Canada R : Mexico C : China I : Malaysia
 Y : PX(Far East,Hawaii) T : England E : Europe G : Germany V : China(Shanghai)
 Y : AAFES(Europe) X : Australia Q : Russia H : Korea M : Other Areas Δ indicates safety critical components.

* New Parts

Parts without **Parts No.** are not supplied.Les articles non mentionnés dans le **Parts No.** ne sont pas fournis.Teile ohne **Parts No.** werden nicht geliefert.

42

Ref. No	Add-ress	New Parts	Parts No.	Description	Desti-nation	Re-marks
J101		*	E63-1173-05	PIN JACK		Y1M1X1
J101		*	E63-1176-05	PIN JACK		K1P2
J102		*	E63-1174-05	PIN JACK		E2V
J102		*	E63-1174-05	PIN JACK		KP1E1
J102		*	E63-1174-05	PIN JACK		Y1M1X1
J102		*	E63-1177-05	PIN JACK		K1P2
J103		*	E63-1178-05	PIN JACK		E2V
J103		*	E63-1178-05	PIN JACK		KP1E1
J103		*	E63-1178-05	PIN JACK		Y1M1X1
J103		*	E63-1179-05	PIN JACK		K1P2
J201			E11-0907-05	MINIATURE PHONE JACK(2.5MM 1P)		
J202			E11-0347-05	MINIATURE PHONE JACK(2P)		
J203,204			E11-0905-05	MINIATURE PHONE JACK(3.5MM 1P)		E2
J203,204			E11-0905-05	MINIATURE PHONE JACK(3.5MM 1P)		KP1K1
J203,204			E11-0905-05	MINIATURE PHONE JACK(3.5MM 1P)		P2E1Y1
J207,208			E11-0905-05	MINIATURE PHONE JACK(3.5MM 1P)		E2
J207,208			E11-0905-05	MINIATURE PHONE JACK(3.5MM 1P)		KP1K1
J207,208			E11-0905-05	MINIATURE PHONE JACK(3.5MM 1P)		P2E1Y1
J209			E11-0291-05	MINIATURE PHONE JACK(2P)		E2
J209			E11-0291-05	MINIATURE PHONE JACK(2P)		KP1K1
J209			E11-0291-05	MINIATURE PHONE JACK(2P)		P2E1Y1
E1			J19-6056-04	HOLDER		
E3 ,4			J11-0809-05	WIRE CLAMPER		
L401			L40-1011-17	SMALL FIXED INDUCTOR(100UH,K)		E2
L401			L40-1011-17	SMALL FIXED INDUCTOR(100UH,K)		KP1K1
L401			L40-1011-17	SMALL FIXED INDUCTOR(100UH,K)		P2E1Y1
L403,404			L40-1011-17	SMALL FIXED INDUCTOR(100UH,K)		E2
L403,404			L40-1011-17	SMALL FIXED INDUCTOR(100UH,K)		KP1K1
L403,404			L40-1011-17	SMALL FIXED INDUCTOR(100UH,K)		P2E1Y1
X1			L78-0284-05	RESONATOR (5MHZ)		
Δ R1			RD14NB2E4R7J	RD	4.7	J 1/4W
R4 ,5			RS14KB3A3R9J	FL-PROOF RS	3.9	J 1W
R6			RK73GB1J151J	CHIP R	150	J 1/16W
R6			RK73GB1J151J	CHIP R	150	J 1/16W
R6			RK73GB1J151J	CHIP R	150	J 1/16W
R6			RK73GB1J221J	CHIP R	220	J 1/16W
R7			RK73GB1J301J	CHIP R	300	J 1/16W
Δ R9			RD14NB2E100J	RD	10	J 1/4W
R10 -12			RK73GB1J473J	CHIP R	47K	J 1/16W
R14 -16			RK73GB1J473J	CHIP R	47K	J 1/16W
R17 -67			RK73GB1J474J	CHIP R	470K	J 1/16W
R68			RK73GB1J332J	CHIP R	3.3K	J 1/16W
R69 ,70			RK73GB1J473J	CHIP R	47K	J 1/16W
R71			RK73GB1J105J	CHIP R	1.0M	J 1/16W
R72 -74			RK73GB1J473J	CHIP R	47K	J 1/16W
R75			RK73GB1J333J	CHIP R	33K	J 1/16W
Δ R79			RS14KB3A390J	FL-PROOF RS	39	J 1W
R81			RK73GB1J100J	CHIP R	10	J 1/16W
R82 -85			RK73GB1J221J	CHIP R	220	J 1/16W
R82 -85			RK73GB1J271J	CHIP R	270	J 1/16W
R82 -85			RK73GB1J271J	CHIP R	270	J 1/16W
R86 -90			RK73GB1J301J	CHIP R	300	J 1/16W
R91 ,92			RK73GB1J221J	CHIP R	220	J 1/16W
R91 ,92			RK73GB1J271J	CHIP R	270	J 1/16W

L : Scandinavia K : USA P : Canada R : Mexico C : China I : Malaysia
 Y : PX(Far East,Hawaii) T : England E : Europe G : Germany V : China(Shanghai)
 Y : AAFES(Europe) X : Australia Q : Russia H : Korea M : Other Areas Δ indicates safety critical components.

* New Parts

Parts without **Parts No.** are not supplied.
Les articles non mentionnés dans le **Parts No.** ne sont pas fournis.
Teile ohne **Parts No.** werden nicht geliefert.

43

Ref. No	Address	New Parts	Parts No.	Description	Desti-nation	Re-marks
R91 .92			RK73GB1J271J	CHIP R 270 J 1/16W	M1X1E2	
R91 .92			RK73GB1J271J	CHIP R 270 J 1/16W	P2E1Y1	
R93 -106			RK73GB1J103J	CHIP R 10K J 1/16W		
R112-114			RK73GB1J101J	CHIP R 100 J 1/16W		
R115			RK73GB1J473J	CHIP R 47K J 1/16W		
R118			RD14NB2E101J	RD 100 J 1/4W		
R120			RD14NB2E330J	RD 33 J 1/4W		
R121			RK73GB1J102J	CHIP R 1.0K J 1/16W		
R122			RK73GB1J101J	CHIP R 100 J 1/16W		
R123			RK73GB1J103J	CHIP R 10K J 1/16W		
R124			RK73GB1J101J	CHIP R 100 J 1/16W		
R126,127			RK73GB1J2R2J	CHIP R 2.2 J 1/16W		
R191-193			RD14NB2E100J	RD 10 J 1/4W		
R194-198			RD14NB2E100J	RD 10 J 1/4W		
R199			RK73GB1J00J	CHIP R 10 J 1/16W	K1P2	
R200			RK73GB1J101J	CHIP R 100 J 1/16W		
R201			RK73GB1J102J	CHIP R 1.0K J 1/16W		
R205			RK73GB1J681J	CHIP R 680 J 1/16W		
R211,212			RK73GB1J223J	CHIP R 22K J 1/16W		
R213,214			RK73GB1J101J	CHIP R 100 J 1/16W		
R215,216			RK73GB1J750J	CHIP R 75 J 1/16W		
R217			RK73GB1J474J	CHIP R 470K J 1/16W		
R218			RK73GB1J750J	CHIP R 75 J 1/16W		
R219-225			RK73GB1J513J	CHIP R 51K J 1/16W		
R232			RK73GB1J101J	CHIP R 100 J 1/16W		
R249			RK73GB1J103J	CHIP R 10K J 1/16W		
R298,299			RK73GB1J301J	CHIP R 300 J 1/16W		
R301,302			RK73GB1J224J	CHIP R 220K J 1/16W		
R305,306			RK73GB1J221J	CHIP R 220 J 1/16W		
R307,308			RK73GB1J470J	CHIP R 47 J 1/16W		
R311,312			RK73GB1J224J	CHIP R 220K J 1/16W		
R315,316			RK73GB1J221J	CHIP R 220 J 1/16W		
R317,318			RK73GB1J470J	CHIP R 47 J 1/16W		
R321,322			RK73GB1J224J	CHIP R 220K J 1/16W		
R325,326			RK73GB1J221J	CHIP R 220 J 1/16W		
R327,328			RK73GB1J470J	CHIP R 47 J 1/16W		
R331,332			RK73GB1J224J	CHIP R 220K J 1/16W		
R335,336			RK73GB1J221J	CHIP R 220 J 1/16W		
R337,338			RK73GB1J470J	CHIP R 47 J 1/16W		
R341,342			RK73GB1J224J	CHIP R 220K J 1/16W		
R345,346			RK73GB1J221J	CHIP R 220 J 1/16W		
R347,348			RK73GB1J470J	CHIP R 47 J 1/16W		
R351-370			RK73GB1J222J	CHIP R 2.2K J 1/16W		
R380			RK73GB1J104J	CHIP R 100K J 1/16W		
R401			RD14NB2E471J	RD 470 J 1/4W	E2	
R401			RD14NB2E471J	RD 470 J 1/4W	KP1K1	
R401			RD14NB2E471J	RD 470 J 1/4W	P2E1Y1	
R402			RK73GB1J102J	CHIP R 1.0K J 1/16W	E2	
R402			RK73GB1J102J	CHIP R 1.0K J 1/16W	KP1K1	
R402			RK73GB1J102J	CHIP R 1.0K J 1/16W	P2E1Y1	
R403			RK73GB1J473J	CHIP R 47K J 1/16W	E2	
R403			RK73GB1J473J	CHIP R 47K J 1/16W	KP1K1	
R403			RK73GB1J473J	CHIP R 47K J 1/16W	P2E1Y1	
R404			RK73GB1J102J	CHIP R 1.0K J 1/16W	E2	
R404			RK73GB1J102J	CHIP R 1.0K J 1/16W	KP1K1	
R404			RK73GB1J102J	CHIP R 1.0K J 1/16W	P2E1Y1	

L : Scandinavia K : USA P : Canada R : Mexico C : China I : Malaysia
Y : PX(Far East,Hawaii) T : England E : Europe G : Germany V : China(Shanghai)
Y : AAFES(Europe) X : Australia Q : Russia H : Korea M : Other Areas Δ indicates safety critical components .

* New Parts

Parts without **Parts No.** are not supplied.
Les articles non mentionnés dans le **Parts No.** ne sont pas fournis.
Teile ohne **Parts No.** werden nicht geliefert.

44

Ref. No	Address	New Parts	Parts No.	Description	Desti-nation	Re-marks
R424			RD14NB2E101J	RD 100 J 1/4W	E2	
R424			RD14NB2E101J	RD 100 J 1/4W	KP1K1	
R424			RD14NB2E101J	RD 100 J 1/4W	P2E1Y1	
R425			RK73GB1J102J	CHIP R 1.0K J 1/16W	E2	
R425			RK73GB1J102J	CHIP R 1.0K J 1/16W	KP1K1	
R425			RK73GB1J102J	CHIP R 1.0K J 1/16W	P2E1Y1	
R426			RK73GB1J103J	CHIP R 10K J 1/16W	E2	
R426			RK73GB1J103J	CHIP R 10K J 1/16W	KP1K1	
R426			RK73GB1J103J	CHIP R 10K J 1/16W	P2E1Y1	
R427			RK73GB1J472J	CHIP R 4.7K J 1/16W	E2	
R427			RK73GB1J472J	CHIP R 4.7K J 1/16W	KP1K1	
R427			RK73GB1J472J	CHIP R 4.7K J 1/16W	P2E1Y1	
R428,429			RK73GB1J102J	CHIP R 1.0K J 1/16W	E2	
R428,429			RK73GB1J102J	CHIP R 1.0K J 1/16W	KP1K1	
R428,429			RK73GB1J102J	CHIP R 1.0K J 1/16W	P2E1Y1	
R430			RK73GB1J223J	CHIP R 22K J 1/16W	E2	
R430			RK73GB1J223J	CHIP R 22K J 1/16W	KP1K1	
R430			RK73GB1J223J	CHIP R 22K J 1/16W	P2E1Y1	
R431,432			RD14NB2E471J	RD 470 J 1/4W	E2	
R431,432			RD14NB2E471J	RD 470 J 1/4W	KP1K1	
R431,432			RD14NB2E471J	RD 470 J 1/4W	P2E1Y1	
R433			RK73GB1J101J	CHIP R 100 J 1/16W	E2	
R433			RK73GB1J101J	CHIP R 100 J 1/16W	KP1K1	
R433			RK73GB1J101J	CHIP R 100 J 1/16W	P2E1Y1	
R434			RK73GB1J223J	CHIP R 22K J 1/16W	E2	
R434			RK73GB1J223J	CHIP R 22K J 1/16W	KP1K1	
R434			RK73GB1J223J	CHIP R 22K J 1/16W	P2E1Y1	
R435			RK73GB1J102J	CHIP R 1.0K J 1/16W	E2	
R435			RK73GB1J102J	CHIP R 1.0K J 1/16W	KP1K1	
R435			RK73GB1J102J	CHIP R 1.0K J 1/16W	P2E1Y1	
R436			RK73GB1J272J	CHIP R 2.7K J 1/16W	E2	
R436			RK73GB1J272J	CHIP R 2.7K J 1/16W	KP1K1	
R436			RK73GB1J272J	CHIP R 2.7K J 1/16W	P2E1Y1	
R437			RK73GB1J222J	CHIP R 2.2K J 1/16W	E2	
R437			RK73GB1J222J	CHIP R 2.2K J 1/16W	KP1K1	
R437			RK73GB1J222J	CHIP R 2.2K J 1/16W	P2E1Y1	
R438			RK73GB1J102J	CHIP R 1.0K J 1/16W	E2	
R438			RK73GB1J102J	CHIP R 1.0K J 1/16W	KP1K1	
R438			RK73GB1J102J	CHIP R 1.0K J 1/16W	P2E1Y1	
R439			RD14NB2E471J	RD 470 J 1/4W	E2	
R439			RD14NB2E471J	RD 470 J 1/4W	KP1K1	
R439			RD14NB2E471J	RD 470 J 1/4W	P2E1Y1	
R440,441			RK73GB1J473J	CHIP R 47K J 1/16W	E2	
R440,441			RK73GB1J473J	CHIP R 47K J 1/16W	KP1K1	
R440,441			RK73GB1J473J	CHIP R 47K J 1/16W	P2E1Y1	
R444			RK73GB1J472J	CHIP R 4.7K J 1/16W	E2	
R444			RK73GB1J472J	CHIP R 4.7K J 1/16W	KP1K1	
R444			RK73GB1J472J	CHIP R 4.7K J 1/16W	P2E1Y1	
R445			RK73GB1J102J	CHIP R 1.0K J 1/16W	E2	
R445			RK73GB1J102J	CHIP R 1.0K J 1/16W	KP1K1	
R445			RK73GB1J102J	CHIP R 1.0K J 1/16W	P2E1Y1	
R449			RK73GB1J180J	CHIP R 18 J 1/16W	E2	
R450			RD14NB2E101J	RD 100 J 1/4W	E2	
R450			RD14NB2E101J	RD 100 J 1/4W	KP1K1	
R450			RD14NB2E101J	RD 100 J 1/4W	P2E1Y1	

L : Scandinavia K : USA P : Canada R : Mexico C : China I : Malaysia
Y : PX(Far East,Hawaii) T : England E : Europe G : Germany V : China(Shanghai)
Y : AAFES(Europe) X : Australia Q : Russia H : Korea M : Other Areas Δ indicates safety critical components .

PARTS LIST

KRF-X7775D/X7775D-S/VR-5080/5090

* New Parts

Parts without **Parts No.** are not supplied.Les articles non mentionnés dans le **Parts No.** ne sont pas fournis.Teile ohne **Parts No.** werden nicht geliefert.

45

Ref. No	Add-ress	New Parts	Parts No.	Description	Desti-nation	Re-marks
W202			R92-0679-05	CHIP R	0 OHM	
W203			R92-0670-05	CHIP R	0 OHM	
W204			R92-0679-05	CHIP R	0 OHM	
W206			R92-0670-05	CHIP R	0 OHM	
W207			R92-0679-05	CHIP R	0 OHM	
W208			R92-0670-05	CHIP R	0 OHM	
W209			R92-0679-05	CHIP R	0 OHM	
W210			R92-0670-05	CHIP R	0 OHM	
W213			R92-0670-05	CHIP R	0 OHM	
W216,217			R92-0670-05	CHIP R	0 OHM	
W219			R92-0679-05	CHIP R	0 OHM	
W220			R92-0670-05	CHIP R	0 OHM	
S1 -17			S70-0031-05	TACT SWITCH		
S20			S68-0088-05	PUSH SWITCH (POWER TYPE)	E1Y1M1	
S20			S68-0088-05	PUSH SWITCH (POWER TYPE)	X1E2V	
S19			T99-0602-05	ROTARY ENCODER		
D1 ,2			MTZJ3.3(B)	ZENER DIODE		
D1 ,2			RD3.3ES(B2)	ZENER DIODE		
D13			MTZJ5.1(B)	ZENER DIODE		
D13			RD5.1ES(B2)	ZENER DIODE		
D14			MTZJ5.6(B)	ZENER DIODE		
D14			RD5.6ES(B2)	ZENER DIODE		
D27 ,28			DA204U	DIODE		
D27 ,28			1SS302	DIODE		
D403			DA204U	DIODE		
D403			DA204U	DIODE		
D403			1SS302	DIODE	E2	
D403			1SS302	DIODE	KP1K1	
D403			1SS302	DIODE	P2E1Y1	
D408			DA204U	DIODE	E2	
D408			DA204U	DIODE	KP1K1	
D408			DA204U	DIODE	P2E1Y1	
D408			1SS302	DIODE	E2	
D408			1SS302	DIODE	KP1K1	
D408			1SS302	DIODE	P2E1Y1	
D410			HSS104A	DIODE	E2	
D410			HSS104A	DIODE	KP1K1	
D410			HSS104A	DIODE	P2E1Y1	
D410			1SS133	DIODE	E2	
D410			1SS133	DIODE	KP1K1	
D410			1SS133	DIODE	P2E1Y1	
D411			DA204U	DIODE	E2	
D411			DA204U	DIODE	KP1K1	
D411			DA204U	DIODE	P2E1Y1	
D411			1SS302	DIODE	E2	
D411			1SS302	DIODE	KP1K1	
D411			1SS302	DIODE	P2E1Y1	
D412,413			HSS104A	DIODE	E2	
D412,413			HSS104A	DIODE	KP1K1	
D412,413			HSS104A	DIODE	P2E1Y1	
D412,413			1SS133	DIODE	E2	
D412,413			1SS133	DIODE	KP1K1	
D412,413			1SS133	DIODE	P2E1Y1	
D414			HSS104A	DIODE	E1Y1E2	

L : Scandinavia K : USA P : Canada R : Mexico C : China I : Malaysia

Y : PX(Far East,Hawaii) T : England E : Europe G : Germany V : China(Shanghai)

Y : AAFES(Europe) X : Australia Q : Russia H : Korea M : Other Areas Δ indicates safety critical components .

* New Parts

Parts without **Parts No.** are not supplied.Les articles non mentionnés dans le **Parts No.** ne sont pas fournis.Teile ohne **Parts No.** werden nicht geliefert.

46

Ref. No	Add-ress	New Parts	Parts No.	Description	Desti-nation	Re-marks
D414			1SS133	DIODE		
ED1			16-MT-62GK	FLUORESCENT INDICATOR TUBE	E1Y1E2	
IC1			UPD780204-038	MI-COM IC		
IC11			TC74HC151AF	MOS-IC		
IC401			TC4W53FU	MOS-IC	E2	
IC401			TC4W53FU	MOS-IC	KP1K1	
IC401			TC4W53FU	MOS-IC	P2E1Y1	
Q1 -3			2SC3940A(R,S)	TRANSISTOR		
Q4			DTC124EUA	DIGITAL TRANSISTOR		
Q4			UN5212	DIGITAL TRANSISTOR		
Q5 ,6			DTA124EUA	DIGITAL TRANSISTOR		
Q5 ,6			UN5112	DIGITAL TRANSISTOR		
Q7 -16			DTC124EUA	DIGITAL TRANSISTOR		
Q7 -16			UN5212	DIGITAL TRANSISTOR		
Q20			DTA124EUA	DIGITAL TRANSISTOR		
Q20			UN5112	DIGITAL TRANSISTOR		
Q21			DTC124EUA	DIGITAL TRANSISTOR		
Q21			UN5212	DIGITAL TRANSISTOR		
Q301-320			2SC2878(B)	TRANSISTOR		
Q401			2SC4081(R,S)	TRANSISTOR	E2	
Q401			2SC4081(R,S)	TRANSISTOR		
Q401			2SC4116(Y,GR)	TRANSISTOR	KP1K1	
Q401			2SC4116(Y,GR)	TRANSISTOR	P2E1Y1	
Q401			2SC4116(Y,GR)	TRANSISTOR	E2	
Q401			2SC4116(Y,GR)	TRANSISTOR	KP1K1	
Q401			2SC4116(Y,GR)	TRANSISTOR	P2E1Y1	
Q402			DTC124EUA	DIGITAL TRANSISTOR	E2	
Q402			DTC124EUA	DIGITAL TRANSISTOR	KP1K1	
Q402			DTC124EUA	DIGITAL TRANSISTOR	P2E1Y1	
Q402			UN5212	DIGITAL TRANSISTOR	E2	
Q402			UN5212	DIGITAL TRANSISTOR	KP1K1	
Q402			UN5212	DIGITAL TRANSISTOR	P2E1Y1	
Q412			2SA1576A(R,S)	TRANSISTOR	E2	
Q412			2SA1576A(R,S)	TRANSISTOR	KP1K1	
Q412			2SA1576A(R,S)	TRANSISTOR	P2E1Y1	
Q412			2SA1586(Y,GR)	TRANSISTOR	E2	
Q412			2SA1586(Y,GR)	TRANSISTOR	KP1K1	
Q412			2SA1586(Y,GR)	TRANSISTOR	P2E1Y1	
Q413			DTC124EUA	DIGITAL TRANSISTOR	E2	
Q413			DTC124EUA	DIGITAL TRANSISTOR	KP1K1	
Q413			DTC124EUA	DIGITAL TRANSISTOR	P2E1Y1	
Q413			UN5212	DIGITAL TRANSISTOR	E2	
Q413			UN5212	DIGITAL TRANSISTOR	KP1K1	
Q413			UN5212	DIGITAL TRANSISTOR	P2E1Y1	
Q414			2SC4081(R,S)	TRANSISTOR	E2	
Q414			2SC4081(R,S)	TRANSISTOR	KP1K1	
Q414			2SC4081(R,S)	TRANSISTOR	P2E1Y1	
Q414			2SC4116(Y,GR)	TRANSISTOR	E2	
Q414			2SC4116(Y,GR)	TRANSISTOR	KP1K1	
Q414			2SC4116(Y,GR)	TRANSISTOR	P2E1Y1	
Q415			2SA1576A(R,S)	TRANSISTOR	E2	
Q415			2SA1576A(R,S)	TRANSISTOR	KP1K1	
Q415			2SA1576A(R,S)	TRANSISTOR	P2E1Y1	
Q415			2SA1586(Y,GR)	TRANSISTOR	E2	
Q415			2SA1586(Y,GR)	TRANSISTOR	KP1K1	
Q415			2SA1586(Y,GR)	TRANSISTOR	P2E1Y1	

L : Scandinavia K : USA P : Canada R : Mexico C : China I : Malaysia

Y : PX(Far East,Hawaii) T : England E : Europe G : Germany V : China(Shanghai)

Y : AAFES(Europe) X : Australia Q : Russia H : Korea M : Other Areas Δ indicates safety critical components .

* New Parts

Parts without **Parts No.** are not supplied.
Les articles non mentionnés dans le **Parts No.** ne sont pas fournis.
Teile ohne **Parts No.** werden nicht geliefert.

47

Ref. No	Add-ress	New Parts	Parts No.	Description	Desti-nation	Re-marks
Q416,417			2SC4081(R,S)	TRANSISTOR	E2	
Q416,417			2SC4081(R,S)	TRANSISTOR	KP1K1	
Q416,417			2SC4081(R,S)	TRANSISTOR	P2E1Y1	
Q416,417			2SC4116(Y,GR)	TRANSISTOR	E2	
Q416,417			2SC4116(Y,GR)	TRANSISTOR	KP1K1	
Q416,417			2SC4116(Y,GR)	TRANSISTOR	P2E1Y1	
Q418			DTC124EUA	DIGITAL TRANSISTOR	E2	
Q418			DTC124EUA	DIGITAL TRANSISTOR	KP1K1	
Q418			DTC124EUA	DIGITAL TRANSISTOR	P2E1Y1	
Q418			UN5212	DIGITAL TRANSISTOR	E2	
Q418			UN5212	DIGITAL TRANSISTOR	KP1K1	
Q418			UN5212	DIGITAL TRANSISTOR	P2E1Y1	
Q419			DTA124EUA	DIGITAL TRANSISTOR	E1Y1E2	
Q419			UN5112	DIGITAL TRANSISTOR	E1Y1E2	
A1			W02-2734-05	OPTIC RECEIVING MODULE		
A2			W02-2717-05	OSCILLATING MODULE		
A3 ,4			W02-2716-05	OPTIC RECEIVING MODULE		
A5 -9			W02-2716-05	OPTIC RECEIVING MODULE	K1P2	
VIDEO UNIT (X35-2260-10) VR-5090 only						
C1 -9			CC73GCH1H100D	CHIP C	10PF	D
C10 -15			CE04KW1A101M	ELECTRO	100UF	10WV
C16 -18			CE04KW1A471M	ELECTRO	470UF	10WV
C19 -21			CK73GB1C104K	CHIP C	0.10UF	K
C22 -24			CE04KW1H100M	ELECTRO	10UF	50WV
C25 ,26			CC73GCH1H180J	CHIP C	18PF	J
C27			CE04KW1E470M	ELECTRO	47UF	25WV
C28 -30			CE04KW1H100M	ELECTRO	10UF	50WV
C31			CC73GCH1H271J	CHIP C	270PF	J
C32			CC73GCH1H391J	CHIP C	390PF	J
C33			CK73GB1H472K	CHIP C	4700PF	K
C34			CE04KW1H2R2M	ELECTRO	2.2UF	50WV
C35			CE04KW1E470M	ELECTRO	47UF	25WV
C36			CK73GB1H103K	CHIP C	0.010UF	K
C37 -39			CE04KW1A101M	ELECTRO	100UF	10WV
C40 ,41			CK73GB1H103K	CHIP C	0.010UF	K
C42			CK73GF1C224Z	CHIP C	0.22UF	Z
C43			CC73GCH1H220J	CHIP C	22PF	J
C45			CE04KW1H0R1M	ELECTRO	0.1UF	50WV
C46			CK73GB1H103K	CHIP C	0.010UF	K
C47			CE04KW1H4R7M	ELECTRO	4.7UF	50WV
C48			CK73FF1C105Z	CHIP C	1.0UF	Z
C49			CC73GCH1H102J	CHIP C	1000PF	J
C50			CK73GB1H103K	CHIP C	0.010UF	K
C51 ,52			CK73GF1E104Z	CHIP C	0.10UF	Z
C53			CE04KW1H010M	ELECTRO	1.0UF	50WV
C54			CK73GB1H103K	CHIP C	0.010UF	K
C55			CE04KW1A101M	ELECTRO	100UF	10WV
C56			CK73GF1C224Z	CHIP C	0.22UF	Z
C57			CC73GCH1H221J	CHIP C	220PF	J
C58			CE04KW1H2R2M	ELECTRO	2.2UF	50WV
C59			CK73GB1H103K	CHIP C	0.010UF	K
C60			CC73GCH1H102J	CHIP C	1000PF	J
C61			CK73GF1E104Z	CHIP C	0.10UF	Z
C62 -64			CE04KW1A101M	ELECTRO	100UF	10WV

L : Scandinavia K : USA P : Canada R : Mexico C : China I : Malaysia
Y : PX(Far East,Hawaii) T : England E : Europe G : Germany V : China(Shanghai)
Y : AAFES(Europe) X : Australia Q : Russia H : Korea M : Other Areas Δ indicates safety critical components .

* New Parts

Parts without **Parts No.** are not supplied.
Les articles non mentionnés dans le **Parts No.** ne sont pas fournis.
Teile ohne **Parts No.** werden nicht geliefert.

48

Ref. No	Add-ress	New Parts	Parts No.	Description	Desti-nation	Re-marks
C65 ,66			CK73GB1H103K	CHIP C	0.010UF	K
C67			CE04KW1H100M	ELECTRO	10UF	50WV
C101,102			CE04KW1C470M	ELECTRO	47UF	16WV
C104			CK73GB1H182K	CHIP C	1800PF	K
C105			CC73GCH1H102J	CHIP C	1000PF	J
C106			CE04KW1H220M	ELECTRO	22UF	50WV
C107			CK73FF1C105Z	CHIP C	1.0UF	Z
C108,109			CK73GB1H103K	CHIP C	0.010UF	K
C110			CC73GCH1H101J	CHIP C	100PF	J
C151			CE04KW1E470M	ELECTRO	47UF	25WV
C152			CE04KW1H100M	ELECTRO	10UF	50WV
C153			CK73GF1E104Z	CHIP C	0.10UF	Z
CN1			E40-9832-05	SOCKET FOR PIN ASSY		
J1 -3			E63-1126-05	PIN JACK		
X1			L77-2281-05	CRYSTAL RESONATOR(3.579545 MHZ)		
X3			L78-0711-05	RESONATOR (500KHZ)		
R1 -6			RK73FB2A750J	CHIP R	75	J 1/10W
R7 -9			RK73GB1J104J	CHIP R	100K	J 1/16W
R10 -12			RK73FB2A680J	CHIP R	68	J 1/10W
R13 -15			RK73GB1J1R0J	CHIP R	1	J 1/16W
R16 -20			RK73GB1J473J	CHIP R	47K	J 1/16W
R21			RK73GB1J101J	CHIP R	100	J 1/16W
R22 ,23			RK73GB1J102J	CHIP R	1.0K	J 1/16W
R24			RK73GB1J272J	CHIP R	2.7K	J 1/16W
R25 ,26			RK73GB1J123J	CHIP R	12K	J 1/16W
R27			RK73GB1J473J	CHIP R	47K	J 1/16W
R28			RK73GB1J1R0J	CHIP R	1	J 1/16W
R29			RK73GB1J100J	CHIP R	10	J 1/16W
R30			RK73GB1J1R0J	CHIP R	1	J 1/16W
R31			RK73GB1J222J	CHIP R	2.2K	J 1/16W
R32			RK73GB1J331J	CHIP R	330	J 1/16W
R33			RK73GB1J272J	CHIP R	2.7K	J 1/16W
R34			RK73GB1J432J	CHIP R	4.3K	J 1/16W
R35			RK73GB1J914J	CHIP R	910K	J 1/16W
R36			RK73GB1J242J	CHIP R	2.4K	J 1/16W
R39			RK73GB1J153J	CHIP R	15K	J 1/16W
R40			RK73GB1J684J	CHIP R	680K	J 1/16W
R41			RK73GB1J184J	CHIP R	180K	J 1/16W
R42			RK73GB1J433J	CHIP R	43K	J 1/16W
R43			RK73GB1J103J	CHIP R	10K	J 1/16W
R44			RK73GB1J273J	CHIP R	27K	J 1/16W
R45 ,46			RK73GB1J102J	CHIP R	1.0K	J 1/16W
R47			RK73GB1J182J	CHIP R	1.8K	J 1/16W
R48			RK73GB1J221J	CHIP R	220	J 1/16W
R49			RK73GB1J151J	CHIP R	150	J 1/16W
R50			RK73GB1J750J	CHIP R	75	J 1/16W
R51			RK73GB1J183J	CHIP R	18K	J 1/16W
R52			RK73GB1J223J	CHIP R	22K	J 1/16W
R53			RK73GB1J102J	CHIP R	1.0K	J 1/16W
R55			RK73GB1J392J	CHIP R	3.9K	J 1/16W
R56			RK73GB1J183J	CHIP R	18K	J 1/16W
R57			RK73GB1J223J	CHIP R	22K	J 1/16W
R58			RK73GB1J103J	CHIP R	10K	J 1/16W
R60			RK73GB1J102J	CHIP R	1.0K	J 1/16W

L : Scandinavia K : USA P : Canada R : Mexico C : China I : Malaysia
Y : PX(Far East,Hawaii) T : England E : Europe G : Germany V : China(Shanghai)
Y : AAFES(Europe) X : Australia Q : Russia H : Korea M : Other Areas Δ indicates safety critical components .

PARTS LIST

KRF-X7775D/X7775D-S/VR-5080/5090

HOW TO READ THE PARTS LIST

ABBREVIATION OF MODEL AND MASS PRODUCTION'S DESTINATIONS

MODEL	CNT	Australia	Canada	China	England	Europe	Germany	Korea	Malaysia
	ABB.	X	P	C	T	E	G	H	I
VR-5080	-	-	P1	-	-	-	-	-	-
VR-5090	-	-	P2	-	-	-	-	-	-
KRF-X7775D	-	-	-	-	-	E1	-	-	-
KRF-X7775D-S	-	X1	-	-	-	E2	-	-	-
MODEL	CNT	Mexico	PX/AAFES	Russia	Scandinavia	Shanghai	USA	Other area	
	ABB.	R	Y	Q	L	V	K	M	
VR-5080	-	-	-	-	-	-	K	-	-
VR-5090	-	-	-	-	-	-	K1	-	-
KRF-X7775D	-	-	Y1	-	-	-	-	-	-
KRF-X7775D-S	-	-	-	-	-	V	-	M1	-

* New Parts

Parts without **Parts No.** are not supplied.Les articles non mentionnés dans le **Parts No.** ne sont pas fournis.Teile ohne **Parts No.** werden nicht geliefert.

49

Ref. No	Add-ress	New Parts	Parts No.	Description	Desti-nation	Re-marks
R63 -68			RK73GB1J102J	CHIP R 1.0K	J	1/16W
R69 ,70			RK73GB1J222J	CHIP R 2.2K	J	1/16W
R80			RK73GB1J473J	CHIP R 47K	J	1/16W
R82			RK73GB1J101J	CHIP R 100	J	1/16W
R83			RK73GB1J1R0J	CHIP R 1	J	1/16W
R84 -86			RK73GB1J104J	CHIP R 100K	J	1/16W
R87 -90			RK73GB1J473J	CHIP R 47K	J	1/16W
R93			RK73GB1J103J	CHIP R 10K	J	1/16W
R94 -100			RK73GB1J473J	CHIP R 47K	J	1/16W
R101			RK73GB1J103J	CHIP R 10K	J	1/16W
R102			RK73GB1J273J	CHIP R 27K	J	1/16W
R103			RK73GB1J103J	CHIP R 10K	J	1/16W
R104			RK73GB1J273J	CHIP R 27K	J	1/16W
R105,106			RK73GB1J332J	CHIP R 3.3K	J	1/16W
R107			RK73GB1J182J	CHIP R 1.8K	J	1/16W
R108			RK73GB1J103J	CHIP R 10K	J	1/16W
R109			RK73GB1J223J	CHIP R 22K	J	1/16W
R110			RK73GB1J103J	CHIP R 10K	J	1/16W
R111			RK73GB1J104J	CHIP R 100K	J	1/16W
R112			RK73GB1J101J	CHIP R 100	J	1/16W
R113			RK73GB1J474J	CHIP R 470K	J	1/16W
R114			RK73GB1J183J	CHIP R 18K	J	1/16W
R115,116			RK73GB1J103J	CHIP R 10K	J	1/16W
R117			RK73GB1J222J	CHIP R 2.2K	J	1/16W
R118			RK73GB1J103J	CHIP R 10K	J	1/16W
R119			RK73GB1J1R0J	CHIP R 1	J	1/16W
R120-132			RK73GB1J473J	CHIP R 47K	J	1/16W
R139-144			RK73GB1J4R7J	CHIP R 4.7	J	1/16W
R151,152			RK73GB1J1R0J	CHIP R 1	J	1/16W
R153,154			RK73GB1J102J	CHIP R 1.0K	J	1/16W
VR1 ,2			R12-3100-05	TRIMMING POT.(10K)		
W1 -3			R92-1963-05	JUMPER WIRE (RESISTOR TYPE)		
D3			DAP202U	DIODE		
D3			1SS300	DIODE		
D4			DA204U	DIODE		
D4			1SS302	DIODE		
IC1 -3		*	ADG704BRM	ANALOGUE IC		
IC4		*	CLC5623IM	ANALOGUE IC		
IC5			UPC1830GT	ANALOGUE IC		
IC8			UPC29M05HB	ANALOGUE IC		
IC10			NJM4565M	ANALOGUE IC		
Q1			2SC4081(R,S)	TRANSISTOR		
Q1			2SC4116(Y,GR)	TRANSISTOR		
Q2			2SA1576A(R,S)	TRANSISTOR		
Q2			2SA1586(Y,GR)	TRANSISTOR		
Q3			2SC4081(R,S)	TRANSISTOR		
Q3			2SC4116(Y,GR)	TRANSISTOR		
Q7 ,8			DTA124EUA	DIGITAL TRANSISTOR		
Q7 ,8			UN5112	DIGITAL TRANSISTOR		
Q9 ,10			DTC124EUA	DIGITAL TRANSISTOR		
Q9 ,10			UN5212	DIGITAL TRANSISTOR		
Q11			2SC4081(R,S)	TRANSISTOR		
Q11			2SC4116(Y,GR)	TRANSISTOR		
Q15 -17			2SC4213(B)	TRANSISTOR		

L : Scandinavia

K : USA

P : Canada

R : Mexico

C : China

I : Malaysia

Y : PX(Far East,Hawaii)

T : England

E : Europe

G : Germany

V : China(Shanghai)

Y : AAFES(Europe)

X : Australia

Q : Russia

H : Korea

M : Other Areas

△ indicates safety critical components.

PARTS LIST

KRF-X7775D/X7775D-S/VR-5080/5090

SPECIFICATIONS

KRF-X7775D (for U.K.)

Audio Section

Rated Output Power during stereo operation
 1 kHz, 0.03% T.H.D., 6Ω (DIN/IEC) 130W + 130 W
 20 Hz ~ 20 kHz, 0.03% T.H.D., 6Ω (IEC) 120W + 120 W

Effective Output Power during surround operation (Simultaneous power)

Front
 20 Hz ~ 20 kHz, 0.03% T.H.D. at 6Ω 120W + 120 W
 Center
 20 Hz ~ 20 kHz, 0.03% T.H.D. at 6Ω 120W
 Surround
 20 Hz ~ 20 kHz, 0.03% T.H.D. at 6Ω 120W + 120W

Effective Output Power during surround operation

1 kHz, 0.06% T.H.D. at 6Ω all channel driven (Front, Centre, Surround) 100W × 5

Total Harmonic Distortion 0.005 % (1 kHz, 60 W, 6 Ω)

Frequency Response (IHF'66)

Line (CD1, MD/TAPE, CD2/TAPE2 MONITOR, CD-R, VIDEO 1 - 3, DVD/6CH.) 7 Hz ~ 100 kHz, 0 dB, -3 dB

Signal to Noise Ratio (IHF '66)

PHONO (MM) 76 dB

CD1 98 dB

Input Sensitivity / Impedance

PHONO (MM) 4.0 mV / 47 kΩ

CD1 300 mV / 47 kΩ

DVD/6CH. 300 mV / 47 kΩ

Output Level / Impedance

TAPE REC 300 mV / 2.2 kΩ

PRE OUT (Front, Center, Surround, Surround back) 1 V / 470 Ω

PRE OUT (Subwoofer) 1.8 V / 470 Ω

Tone Control

Bass ± 7 dB (at 100 Hz)

Treble ± 7 dB (at 10 kHz)

Loudness Control Volume at -30 dB level

..... +6 dB (100 Hz), +3 dB (10 kHz)

Digital Audio Section

Sampling Frequency 32 kHz, 44.1 kHz, 48 kHz, 96 kHz

Input Level / Impedance / Wavelength
 Optical -15 dBm ~ -21 dBm, 660 nm ±30 nm
 Coaxial 0.5 Vp-p / 75 Ω

Output Level / Impedance / Wavelength
 Optical -15 dBm ~ -21 dBm, 660 nm ±30 nm

Video Section

Video Inputs / Outputs
 Video (composite) 1 Vp-p / 75 Ω
 S Video (luminance signal) 1 Vp-p / 75 Ω
 (chrominance signal) 0.286 Vp-p / 75 Ω
 Component (luminance signal) 1 Vp-p / 75 Ω
 (Cb/Cr-signal) ±0.350 Vp-p / 75 Ω

FM Tuner Section

Tuning Frequency Range 87.5 MHz ~ 108 MHz

Usable Sensitivity (DIN at 75 Ω)
 Mono 1.3 μV / 13.2 dBf (40 kHz dev., S/N 26 dB)

Stereo 35.1 μV / 42.1 dBf (46 kHz dev., S/N 46 dB)

Total Harmonic Distortion (DIN at 1 kHz)
 Mono 0.2 % (71.2 dBf input)

Stereo 0.8 % (71.2 dBf input)

Signal to Noise Ratio (DIN weighted, 1kHz)

Mono 65 dB (40 kHz dev., 71.2 dBf input)

Stereo 60 dB (40 kHz dev., 71.2 dBf input)

Stereo Separation (DIN at 1 kHz) 36 dB

Selectivity (DIN ±300 kHz) 64 dB

Frequency Response 30 Hz ~ 15 kHz, +0.5 dB, -3.0 dB

AM Tuner Section

Tuning Frequency Range 531 kHz ~ 1,602 kHz

Usable Sensitivity (30 % mod., S/N 20 dB) 16 μV / (500 μV/m)

Signal to Noise Ratio (30 % mod., 1 mV input) 50 dB

IR In/Out Section

IR Receiver In Terminal

Maximum Output Current 20 mA

Operating Voltage 12 V

Output Impedance 470 Ω

IR Out LCD Remote Terminal

Maximum Output Current 20 mA

Operating Voltage 5 V

Output Impedance 470 Ω

SHAPE OF PLUG TO BE CONNECTED:

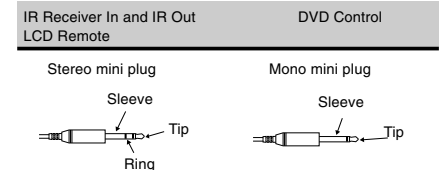

IR IN/OUT SPECIFICATION:

	Terminal	
	IR Receiver In	IR Out LCD Remote
To Tip	Signal	Signal
To Ring	Ground	—
To Sleeve	+12V	Ground

General

Power consumption 500 W

AC outlet
 Switched 2 (total 90 W max.)

Dimensions W : 440mm

H : 191mm

D : 416mm

Weight (Net) 16.8 kg

KRF-X7775D (for Other Countries)

Audio Section

Rated Output Power during stereo operation
 20 Hz ~ 20 kHz, 0.7% T.H.D., 6Ω (IEC) 130W + 130 W
 120 watts per channel minimum RMS, both channels driven, at 6 Ω from 20Hz to 20kHz with no more than 0.05% total harmonic distortion (FTC).

Effective Output Power during stereo operation
 1 kHz, 10% T.H.D. at 6 Ω 170 W + 170 W

Effective Output Power during surround operation, one channel driven

Front
 1 kHz, 10% T.H.D. at 6 Ω 180 W + 180 W
 20 Hz ~ 20 kHz, 0.06% T.H.D. at 6 Ω 150 W + 150 W
 Center
 1 kHz, 10% T.H.D. at 6 Ω 180 W
 20 Hz ~ 20 kHz, 0.06% T.H.D. at 6 Ω 150 W
 Surround
 1 kHz, 10% T.H.D. at 6 Ω 180 W + 180 W
 20 Hz ~ 20 kHz, 0.06% T.H.D. at 6 Ω 150 W + 150 W

Effective Output Power during surround operation, all channel driven (Front, Center, Surround)

1 kHz, 0.006% T.H.D. at 6 Ω 95 W × 5

Total Harmonic Distortion 0.005 % (1 kHz, 65 W, 6 Ω)

Frequency Response (IHF'66)

Line (CD1, MD/TAPE, CD2/TAPE2 MONITOR, CD-R, VIDEO 1 - 3, DVD/6CH.) 7 Hz ~ 100 kHz, 0 dB, -3 dB

Signal to Noise Ratio (IHF '66)

PHONO (MM) 76 dB

CD1 98 dB

Input Sensitivity / Impedance

PHONO (MM) 4.0 mV / 47 kΩ

CD1 300 mV / 47 kΩ

DVD/6CH. 300 mV / 47 kΩ

Output Level / Impedance

TAPE REC 300 mV / 2.2 k Ω

PRE OUT (Front, Center, Surround, Surround back) 1 V / 470 Ω

PRE OUT (Subwoofer) 1.8 V / 470 Ω

Tone Control

Bass ± 7 dB (at 100 Hz)

Treble ± 7 dB (at 10 kHz)

Loudness Control

Volume at -30 dB level +6 dB (100 Hz), +3 dB (10 kHz)

Digital Audio Section

Sampling Frequency 32 kHz, 44.1 kHz, 48 kHz, 96 kHz

Input Level / Impedance / Wavelength
 Optical -15 dBm ~ -21 dBm, 660 nm ±30 nm
 Coaxial 0.5 Vp-p / 75 Ω

Output Level / Impedance / Wavelength
 Optical -15 dBm ~ -21 dBm, 660 nm ±30 nm

Video Section

Video Inputs / Outputs
 Video (composite) 1 Vp-p / 75 Ω
 S Video (luminance signal) 1 Vp-p / 75 Ω
 (chrominance signal) 0.286 Vp-p / 75 Ω
 Component (luminance signal) 1 Vp-p / 75 Ω
 (Cb/Cr-signal) ±0.350 Vp-p / 75 Ω

FM Tuner Section

Tuning Frequency Range 87.5 MHz ~ 108 MHz

Usable Sensitivity (Mono)
 1.3 μV (75 Ω) / 13.2 dBf (75 kHz dev., sinad 30 dB)

50dB Quieting Sensitivity
 Stereo 25.1 μV (75 Ω) / 39.2 dBf

Total Harmonic Distortion (1 kHz)
 Mono 0.3 % (71.2 dBf input)

Stereo 0.5 % (71.2 dBf input)

Signal to Noise Ratio (1 kHz, 75 kHz DEV.)

Mono 75 dB (71.2 dBf input)

Stereo 70 dB (71.2 dBf input)

Stereo Separation (1 kHz) 40 dB

Selectivity (±400 kHz) 50 dB

Frequency Response 30 Hz ~ 15 kHz, +0.5 dB, -3.0 dB

AM Tuner Section

Tuning Frequency Range 531 kHz ~ 1,602 kHz

9kHz step 530 kHz ~ 1,610 kHz

10kHz step 530 kHz ~ 1,610 kHz

Usable Sensitivity (30 % mod., S/N 20 dB) 16 μV / (500 μV/m)

Signal to Noise Ratio (30 % mod. 1 mV input) 50 dB

IR In/Out Section (for U. S. military)

IR Receiver In Terminal

Maximum Output Current 20 mA

Operating Voltage 12 V

Output Impedance 470 Ω

IR Out LCD Remote Terminal

Maximum Output Current 20 mA

Operating Voltage 5 V

Output Impedance 470 Ω

SHAPE OF PLUG TO BE CONNECTED:

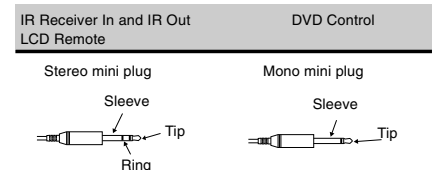

IR IN/OUT SPECIFICATION:

	Terminal	
	IR Receiver In	IR Out LCD Remote
To Tip	Signal	Signal
To Ring	Ground	—
To Sleeve	+12V	Ground

General

Power consumption 500 W

AC outlet
 Switched (except for Australia) 2 (total 90 W max.)

Switched (for Australia) 1 (total 90 W max.)

Dimensions W : 440mm

H : 191mm

D : 416mm

Weight (Net) 16.8 kg

Kenwood follows a policy of continuous advancements in development. For this reason, specifications may be changed without notice.

Full performance may not be exhibited in extremely cold locations (below 0 deg. C).

KRF-X7775D/X7775D-S/VR-5080/5090

SPECIFICATIONS

VR-5090/VR-5080

Audio Section

Rated Output Power during stereo operation

110 watts per channel minimum RMS, both channels driven, at 6 Ω from 20Hz to 20kHz with no more than 0.03% total harmonic distortion (FTC).

Effective Output Power during surround operation

1 kHz, 0.06% T.H.D. at 6 Ω, all channel driven (Front, Center, Surround) 80 W × 5

Total Harmonic Distortion 0.005 % (1 kHz, 55 W, 6 Ω)

Frequency Response (IHF'66)

VR-5090

Line (CD1, MD/TAPE, CD2/TAPE2 MONITOR, CD-R, VIDEO 1 - 4, DVD/6CH.) 7 Hz ~ 100 kHz, 0 dB, -3 dB

VR-5080

Line (CD1, MD/TAPE, CD2/TAPE2 MONITOR, CD-R, VIDEO 1 - 3, DVD/6CH.) 7 Hz ~ 100 kHz, 0 dB, -3 dB

Signal to Noise Ratio (IHF '66)

PHONO (MM) 76 dB
CD1 98 dB

Input Sensitivity / Impedance

PHONO (MM) 4.0 mV / 47 kΩ
CD1 300 mV / 47 kΩ
DVD/6CH. 300 mV / 47 kΩ

Output Level / Impedance

TAPE REC 300 mV / 2.2 kΩ
PRE OUT (Front, Center, Surround, Surround back) 1 V / 470 Ω
PRE OUT (Subwoofer) 1.8 V / 470 Ω

Tone Control

Bass ±7 dB (at 100 Hz)
Treble ±7 dB (at 10 kHz)

Loudness Control

Volume at -30 dB level +6 dB (100 Hz), +3 dB (10 kHz)

Digital Audio Section

Sampling Frequency 32 kHz, 44.1 kHz, 48 kHz, 96 kHz
Input Level / Impedance / Wavelength

Optical -15 dBm ~ -21 dBm, 660 nm ±30 nm
Coaxial 0.5 Vp-p / 75 Ω

Output Level / Impedance / Wavelength

VR-5090

Optical -15 dBm ~ -21 dBm, 660 nm ±30 nm
Coaxial 0.5 Vp-p / 75 Ω

VR-5080

Optical -15 dBm ~ -21 dBm, 660 nm ±30 nm

Video Section

Video Inputs / Outputs

Video (composite) 1 Vp-p / 75 Ω
S Video (luminance signal) 1 Vp-p / 75 Ω
(chrominance signal) 0.286 Vp-p / 75 Ω
Component (luminance signal) 1 Vp-p / 75 Ω
(Pb/Pa-signal) ±0.324 Vp-p / 75 Ω

FM Tuner Section

Tuning Frequency Range 87.5 MHz ~ 108 MHz

Usable Sensitivity (Mono)

..... 1.2 μV (75 Ω) / 12.2 dBf (75 kHz dev., sinad 30 dB)

50dB Quieting Sensitivity

Stereo 22.4 μV (75Ω) / 38.2 dBf

Total Harmonic Distortion (1 kHz)

Mono 0.3 % (71.2 dBf input)
Stereo 0.5 % (71.2 dBf input)

Signal to Noise Ratio (1 kHz, 75 kHz DEV.)

Mono 75 dB (71.2 dBf input)
Stereo 70 dB (71.2 dBf input)

Stereo Separation (1 kHz) 40 dB

Selectivity (±400 kHz) 70 dB

Frequency Response 30 Hz ~ 15 kHz, +0.5 dB, -3.0 dB

AM Tuner Section

Tuning Frequency Range

10kHz step 530 kHz ~ 1,700 kHz

Usable Sensitivity (30 % mod., S/N 20 dB)

..... 16 μV / (500 μV/m)

Signal to Noise Ratio (30 % mod. 1 mV input) 50 dB

IR In/Out Section

IR Receiver In Terminal

Maximum Output Current 20 mA
Operating Voltage 12 V
Output Impedance 470 Ω

IR Out LCD Remote Terminal

Maximum Output Current 20 mA
Operating Voltage 5 V
Output Impedance 470 Ω

IR Repeater Out Terminal

Maximum Output Current 20 mA
Operating Voltage 12 V
Output Impedance 470 Ω

SHAPE OF PLUG TO BE CONNECTED:

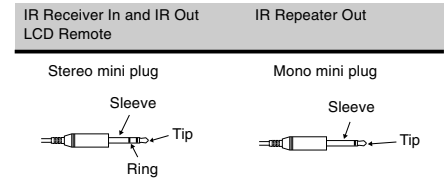

IR IN/OUT SPECIFICATION:

Terminal	IR Receiver In	IR Out LCD Remote
To Tip	Signal	Signal
To Ground	Ground	—
To Sleeve	+12V	Ground

General

Power consumption 5 A

AC outlet Switched 2 (total 90W, 0.75 A max.)

Dimensions W: 440mm (17-5/16")

..... H: 191mm (7-1/2")

..... D: 416mm (16-3/8")

Weight (Net) 15.0 kg (33.0 lb)

KENWOOD CORPORATION

14-6, Dogenzaka 1-chome, Shibuya-ku, Tokyo, 150-8501 Japan

KENWOOD SERVICE CORPORATION

P.O. BOX 22745, 2201 East Dominguez St., Long Beach, CA 90801-5745, U.S.A.

KENWOOD ELECTRONICS CANADA INC.

6070 Kestrel Road, Mississauga, Ontario, Canada L5T 1S8

KENWOOD ELECTRONICS LATIN AMERICA S.A.

P.O. BOX 55-2791, Piso 6 plaza Chase, Cl. 47 y Aquilino de la Guardia Panama, Republic de Panama

KENWOOD ELECTRONICS BRASIL LTDA.

Av. Moema, 170-17", Andar-Cobertura "B", Ed. Maximum Service Center, 04077-020 Moema, São Paulo-SP-Brasil

KENWOOD ELECTRONICS U.K. LIMITED

KENWOOD House, Dwight Road, Watford, Herts., WD1 8EB., United Kingdom

KENWOOD ELECTRONICS BELGUM N.V.

Meachelsesteenweg 418, B-1930 Zaventem, Belgium

KENWOOD ELECTRONICS DEUTSCHLAND GMBH

Rembrücker Str. 15, 63150 Heusenstamm, Germany

KENWOOD ELECTRONICS FRANCE S.A.

13 Boulevard Ney, 75018 Paris, France

KENWOOD ELECTRONICS ITALIA S.p.A.

Via G. Sirtori, 7/9 20129, Milano, Italy

KENWOOD IBÉRICA S.A.

Bolivia, 239-08020 Barcelona, Spain

KENWOOD ELECTRONICS AUSTRALIA PTY. LTD.

(A.C.N. 001 499 074)
16 Giffnock Avenue, North Ryde, N.S.W. 2113, Australia

KENWOOD ELECTRONICS (HONG KONG) LTD.

Unit 3712-3724, Level 37, Tower 1, Metroplaza, 223 Hing Fong Road, Kwai Fong N.T., Hong Kong

KENWOOD ELECTRONICS GULF FZE

P.O. Box 61318, Jebel Ali, Dubai, U.A.E.

KENWOOD ELECTRONICS SINGAPORE PTE LTD.

No. 1 Genting Lane #02-02, KENWOOD Building, Singapore, 349544

KENWOOD ELECTRONICS (MALAYSIA) SDN BHD.

#4.01 Level 4, Wisma Academy Lot 4A, Jalan 19/1 46300 Petaling Jaya Selangor Darul Ehsan Malaysia

KENWOOD ELECTRONICS (THAILAND) CO., LTD.

2019 New Pechburi Road, Bangkapi, Huaykwang, Bangkok, 10320 Thailand