

KRF-V4060D (X08-3160-10)			KRF-V4060DE (X08-3160-10)			VR-605 (X08-3160-10)			KRF-V5060D-S (X08-3160-XX)			VR-615 (X08-3160-10)			KRF-V5560D-S (X08-3160-XX)		
DESTINATION	UNIT		DESTINATION	UNIT		DESTINATION	UNIT		DESTINATION	UNIT		DESTINATION	UNIT		DESTINATION	UNIT	
COUNTRY	ABB.	No.	COUNTRY	ABB.	No.	COUNTRY	ABB.	No.	COUNTRY	ABB.	No.	COUNTRY	ABB.	No.	COUNTRY	ABB.	No.
EUROPE	E	0-10	EUROPE	E1	0-10	U.S.A.	K	0-10	EUROPE	E3	0-10	U.S.A.	K	0-10	EUROPE	E	0-10
U.K.	T		U.K.	T1		CANADA	P		U.K.	T1	0-10	CANADA	P		U.K.	T	
									AUSTRALIA	X					AUSTRALIA	X	0-10
									GENERAL MARKET	M	0-21				KOREA	H	
															GENERAL MARKET	M	0-21

IC601 : CS493264-CLR	IC609 : XC62EP2502MR	Q601,602 : DTC124EUA or UN5212	D601,608,611-614 : MA111	D604 : UDZ3.9B or HZU3.9(B2)
IC602 : AK4586	IC611 : BA03LBSG	Q606 : 2SB1375	D602,605 : 1SS301 or DAN202U or MA142WK	D606,607 : HZU5.6(B2) or HZU5.6(B2)
IC603 : TC7WU04FU	IC612 : BA05T	Q608 : 2SC4081(R,S) or 2SD1819A(Q,R)	D603 : 1SS300 or DAF202U or MA142WA	D609 : D2SBA20F03
IC604 : TC7WH123FU	IC701-703,707 : NUM4565MD	Q609 : 2SA1576A(R,S) or 2SB1218A(Q,R)		D610 : UDZ5.1B or HZU5.1(B2)
IC605 : TC74HCT7007AF	IC705 : NUJ7311AM			
IC606 : TC74HC07AF				

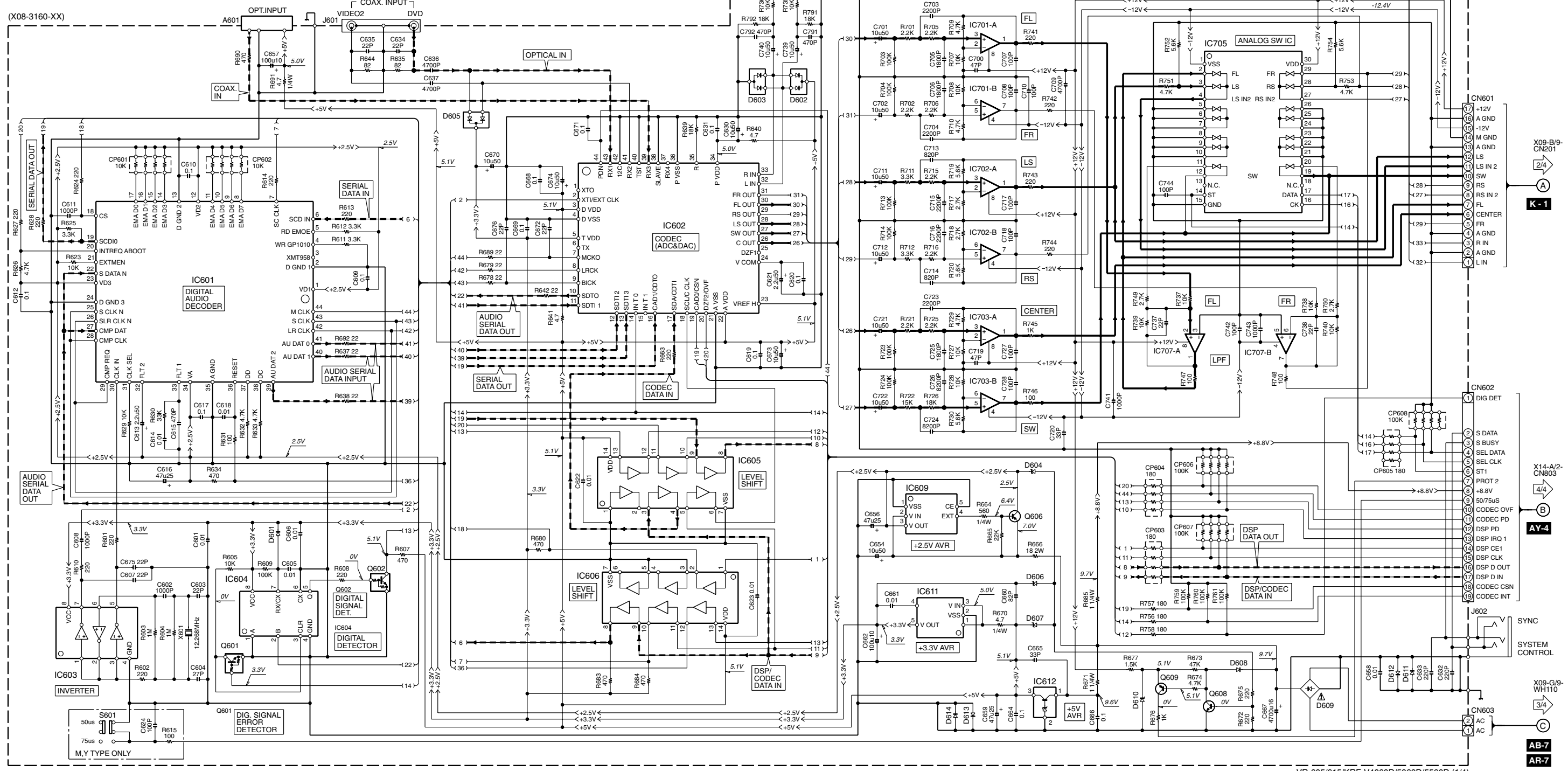
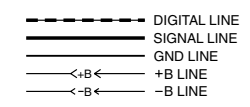

VR-605/615/KRF-V4060D/5060D/5560D (1/4)

CAUTION: For continued safety, replace safety critical components only with manufacturer's recommended parts (refer to parts list). Δ indicates safety critical components. For continued protection against risk of fire, replace only with same type and rating fuse(s). To reduce the risk of electric shock, leakage-current or resistance measurements shall be carried out (exposed parts are acceptably insulated from the supply circuit) before the appliance is returned to the customer.

The DC voltage is an actual reading measured with a high impedance type voltmeter with a cassette loaded at playback mode. The measurement value may vary depending on the measuring instruments used or on the product. Bias circuit DC voltage is measured while in the record mode.

downloaded from <http://receiverfaq.ru/>

KRF-V4060D/V5060D/V5560D/VR-605/615

KENWOOD

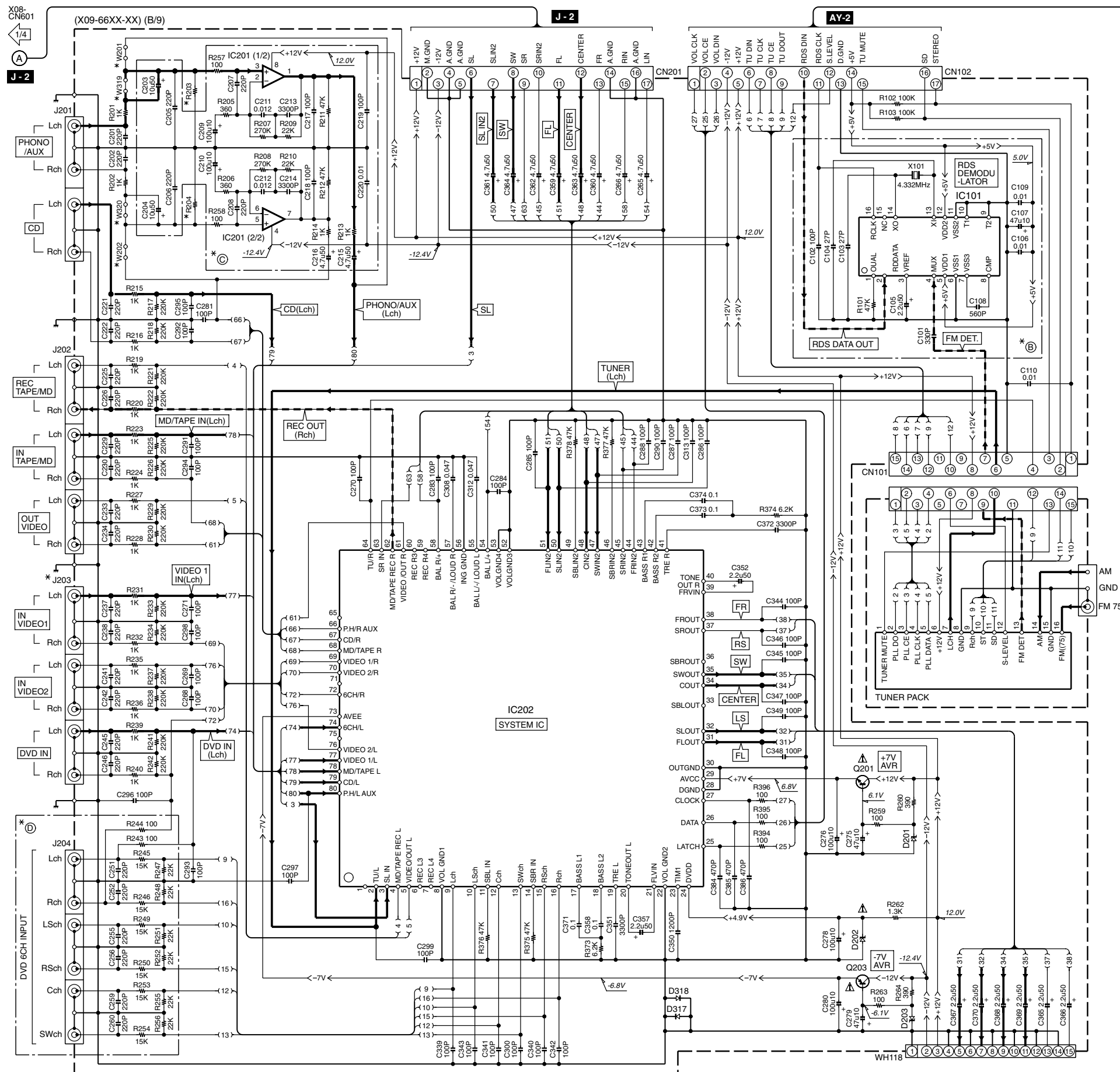

KRF-V4060D (X09-660X-XX)

DESTINATION	COUNTRY	ABB.	UNIT No.	(B)	(C)	(D)	J203	R203, 204	W201,202, 319,320
EUROPE	E	2-72		YES	NO		E63-1258-05	47K	YES
U.K.	T	0-52							

KRF-V4060D-S (X09-660X-XX)

DESTINATION	COUNTRY	ABB.	UNIT No.	(B)	(C)	(D)	J203	R203, 204	W201,202, 319,320
EUROPE	E3	2-72		YES	NO		E63-1258-05	47K	YES
U.K.	T1	0-52							
AUSTRALIA	X	0-72		NO	NO		E63-1258-05	47K	YES
GENERAL MARKET	M	0-22							

KRF-V4060DE (X09-6602-72)

DESTINATION	COUNTRY	ABB.	UNIT No.	(B)	(C)	(D)	J203	R203, 204	W201,202, 319,320
EUROPE	E1	2-72		YES	NO		E63-1258-05	47K	YES

KRF-V4060DE-S (X09-6602-72)

DESTINATION	COUNTRY	ABB.	UNIT No.	(B)	(C)	(D)	J203	R203, 204	W201,202, 319,320
EUROPE	E2	2-72		YES	NO		E63-1258-05	47K	YES

VR-605 (X09-6600-10)

DESTINATION	COUNTRY	ABB.	UNIT No.	(B)	(C)	(D)	J203	R203, 204	W201,202, 319,320
U.S.A.	K	0-10		NO	NO		E63-1258-05	47K	YES
CANADA	P	0-10							

KRF-V5060D (X09-660X-XX)

DESTINATION	COUNTRY	ABB.	UNIT No.	(B)	(C)	(D)	J203	R203, 204	W201,202, 319,320
EUROPE	E	2-71		YES	YES		E63-1256-05	30K	NO
U.K.	T	0-51							YES
PX	Y	2-91		NO	NO			47K	NO

KRF-5060D-S (X09-660X-XX)

DESTINATION	COUNTRY	ABB.	UNIT No.	(B)	(C)	(D)	J203	R203, 204	W201,202, 319,320
EUROPE	E3	2-71		YES	YES		E63-1256-05	30K	NO
U.K.	T1	0-51							YES
AUSTRALIA	X	0-71		NO	YES		E63-1256-05	47K	YES
GENERAL MARKET	M	0-21							

KRF-5060DE (X09-6602-71)

DESTINATION	COUNTRY	ABB.	UNIT No.	(B)	(C)	(D)	J203	R203, 204	W201,202, 319,320
EUROPE	E1	2-71		YES	YES		E63-1256-05	30K	NO

VR-615 (X09-6610-10)

DESTINATION	COUNTRY	ABB.	UNIT No.	(B)	(C)	(D)	J203	R203, 204	W201,202, 319,320
U.S.A.	K	0-10		NO	YES		E63-1256-05	47K	YES
CANADA	P	0-10							

KRF-V5560D (X09-6612-XX)

DESTINATION	COUNTRY	ABB.	UNIT No.	(B)	(C)	(D)	J203	R203, 204	W201,202, 319,320
EUROPE	E	2-71		YES	NO		E63-1258-05	47K	YES
PX	Y	2-91		NO	NO				

KRF-V5560D-S (X09-661X-XX)

DESTINATION	COUNTRY	ABB.	UNIT No.	(B)	(C)	(D)	J203	R203, 204	W201,202, 319,320
EUROPE	E3	2-71		YES	NO		E63-1258-05	47K	YES
U.K.	T1	0-51							
AUSTRALIA	X	0-71		NO	NO		E63-1258-05	47K	YES
KOREA	H	4-11							
GENERAL MARKET	M	0-21							

- IC101 : BU1923
- IC201 : NJM4580L-D
- IC202 : M61516FP
- Q201 : 2SC1845(F,E)
- Q203 : 2SA992(F,E)
- D201,203 : MTZJ6.8(B) or HZS6.8N(B2)
- D202 : MTZJ5.1(B) or HZS5.1N(B2)
- D317,318 : 1SS133 or HSS104A

CAUTION: For continued safety, replace safety critical components only with manufacturer's recommended parts (refer to parts list). ⚠ indicates safety critical components. For continued protection against risk of fire, replace only with same type and rating fuse(s). To reduce the risk of electric shock, leakage-current or resistance measurements shall be carried out (exposed parts are acceptably insulated from the supply circuit) before the appliance is returned to the customer.

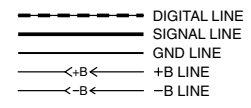

MODE	CARRIER	MODULATION		ANT INPUT
		FREQUENCY	DEVIATION	
FM	98MHz	1kHz	STEREO 67.5kHz 7.5kHz(Pilot)	60dB
AM	1000(999)kHz	400Hz	MONO 30% MOD	60dB

The DC voltage is an actual reading measured with a high impedance type voltmeter as the AM/FM signal generator is specified to the conditions as shown in the list below. The measurement value may vary depending on the measuring instruments used or on the product. The value shown in () is actual reading measured in the AM mode.

U-3
AJ-3

VR-605/615/KRF-V4060D/5060D/5560D (2/4)

U-3
AJ-3

KRF-V4060D/V5060D/V5560D/VR-605/615

Y05-4530-10

KENWOOD

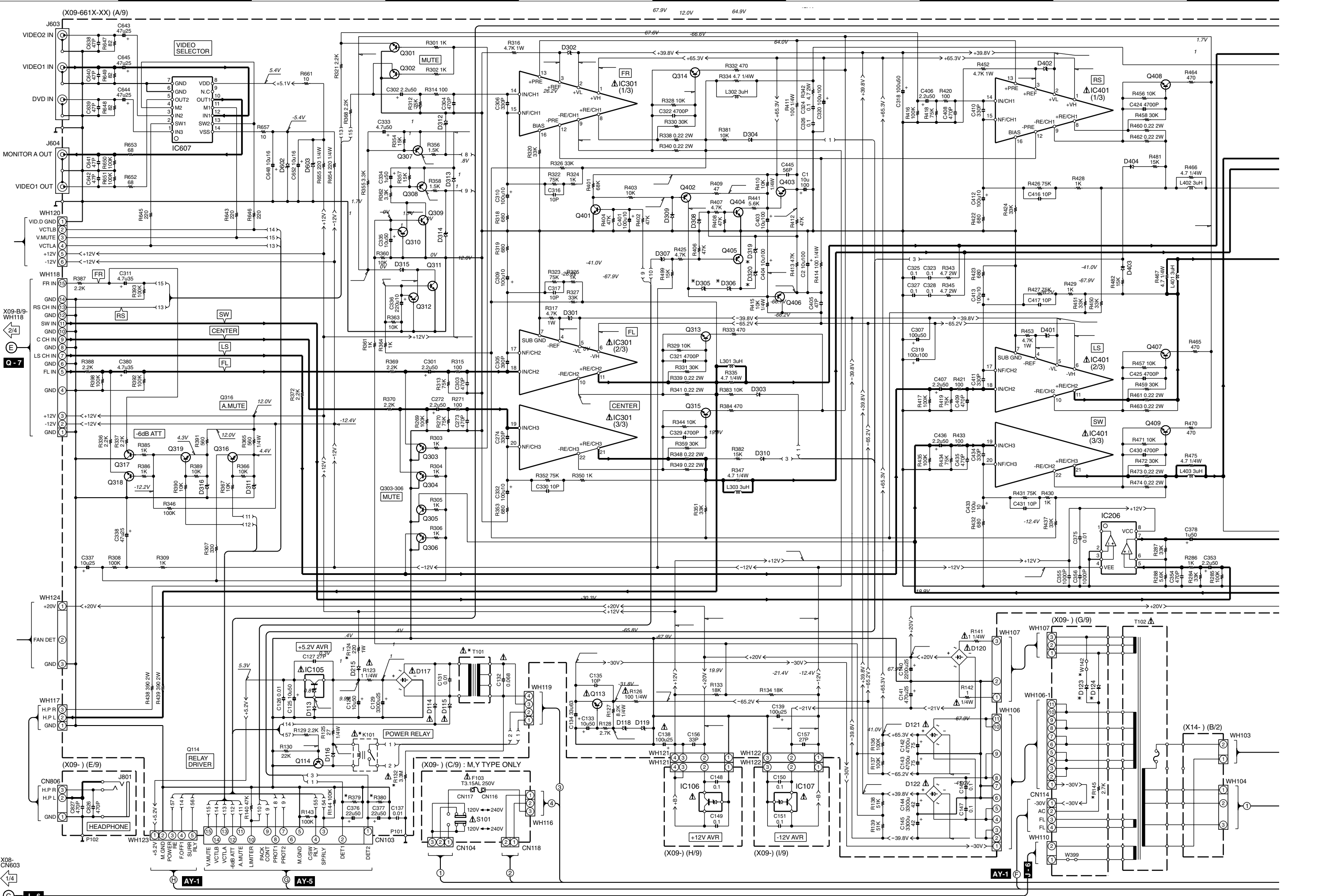

(X09-661x-xx) (A/9)

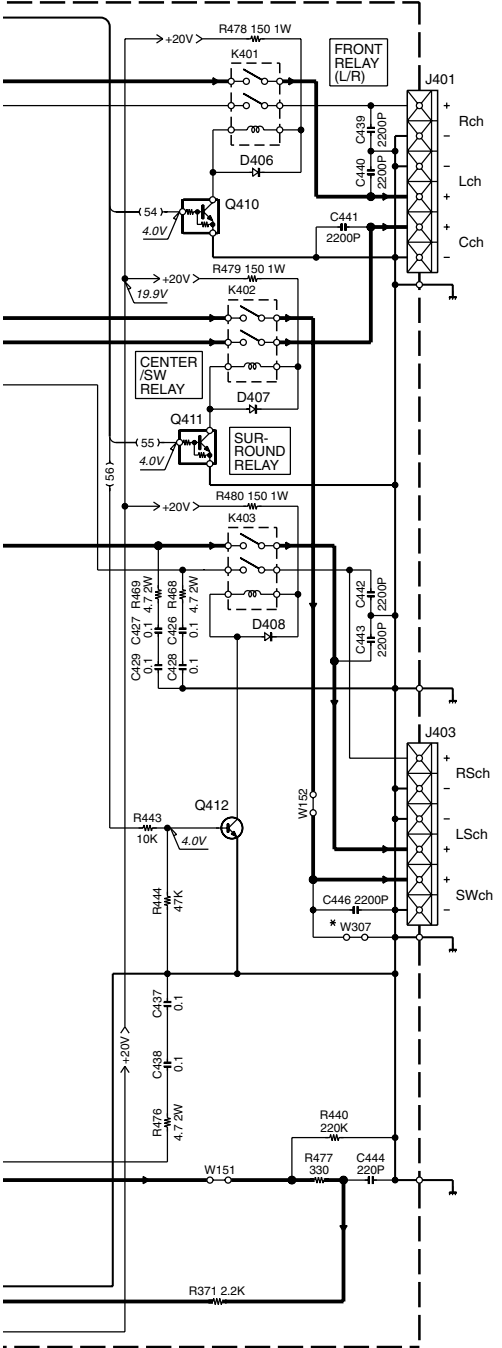

VR615 (X09-6610-10)

DESTINATION	UNIT ABB.	C130	CN106	CN112	D123	D305, 306	D319, 320	F101	F102	J205	J206	K101	R124, R132	R124, R145	R379, 380	S102	T101	W321, 387	W142	W143, 397	
U.S.A.	K	0.088 or 8800P	NO	NO	NO	MTZJ11(B) or HZS11N(B2)	MTZJ11(B) or HZS11N(B2)	6A 125V	NO	NO	NO	NO	NO	NO	NO	NO	NO	NO	NO	NO	NO
CANADA	P	0.088 or 8800P	NO	NO	NO	MTZJ11(B) or HZS11N(B2)	MTZJ11(B) or HZS11N(B2)	125V	NO	NO	NO	NO	NO	NO	NO	NO	NO	NO	NO	NO	NO

KRF-V5560D (X09-6612-XX)

DESTINATION	UNIT ABB.	C130	CN108	CN115	D123	D305, 306	D319	D320	F101	F102	J205	J206	K101	R124, R145	R132	S102	T101	W142	W143, 397	
EUROPE	E	8800P	YES	NO	NO	MTZJ10(B) or HZS10N(B2)	MTZJ11(B) or HZS11N(B2)	MTZJ13(B) or HZS13N(B2)	T3,15AAL 250V	YES	NO	NO	NO	NO	NO	NO	NO	NO	NO	NO
PX	Y	8800P	NO	NO	YES	MTZJ10(B) or HZS10N(B2)	MTZJ11(B) or HZS11N(B2)	MTZJ15(B) or HZS15N(B2)	T3,15AAL 250V	NO	NO	NO	NO	NO	NO	NO	NO	NO	NO	NO

KRF-V5560D-S (X09-661X-XX)

DESTINATION	UNIT ABB.	C130	CN108	CN112	D123	D305, 306	D319	D320	F101	F102	J205	J206	K101	R124, R145	R132	S102	T101	W142	W143, 397	
EUROPE	E3	2-71	YES	YES	NO	MTZJ10(B) or HZS10N(B2)	MTZJ11(B) or HZS11N(B2)	MTZJ13(B) or HZS13N(B2)	T3,15AAL 250V	YES	NO	NO	NO	NO	NO	NO	NO	NO	NO	NO
U.K.	T1	0-51	YES	YES	NO	MTZJ10(B) or HZS10N(B2)	MTZJ11(B) or HZS11N(B2)	MTZJ13(B) or HZS13N(B2)	T3,15AAL 250V	YES	NO	NO	NO	NO	NO	NO	NO	NO	NO	NO
AUSTRALIA	X	0-71	NO	NO	NO	MTZJ10(B) or HZS10N(B2)	MTZJ11(B) or HZS11N(B2)	MTZJ13(B) or HZS13N(B2)	T3,15AAL 250V	NO	NO	NO	NO	NO	NO	NO	NO	NO	NO	NO
GENERAL MARKET	M	0-21	NO	NO	NO	MTZJ10(B) or HZS10N(B2)	MTZJ11(B) or HZS11N(B2)	MTZJ13(B) or HZS13N(B2)	T3,15AAL 250V	NO	NO	NO	NO	NO	NO	NO	NO	NO	NO	NO
KOREA	H	4-11	NO	NO	NO	MTZJ10(B) or HZS10N(B2)	MTZJ11(B) or HZS11N(B2)	MTZJ13(B) or HZS13N(B2)	T3,15AAL 250V	NO	NO	NO	NO	NO	NO	NO	NO	NO	NO	NO

- IC105 : BA05T
- IC106 : KIA7812API
- IC107 : KIA7912PI
- IC206 : NJM4565D
- IC301,401 : STK413-220A or STK413-020A
- IC607 : NJM2279D

- Q113,406 : 2SB1640
- Q114,412 : 2SC1740S(Q,R) or 2SC2878(F,E)
- Q301-306,317,318 : 2SC2878(B)
- Q307,308,316,319,405 : 2SA992(F,E)
- Q309-315,401,404, 407-409 : 2SC1845(F,E)
- Q402 : 2SA1535A
- Q403 : 2SC3944A
- Q410,411 : UN4219 or DTC113ZSA

CAUTION: For continued safety, replace safety critical components only with manufacturer's recommended parts (refer to parts list). Δ indicates safety critical components. For continued protection against risk of fire, replace only with same type and rating fuse(s). To reduce the risk of electric shock, leakage-current or resistance measurements shall be carried out (exposed parts are acceptably insulated from the supply circuit) before the appliance is returned to the customer.

The DC voltage is an actual reading measured with a high impedance type voltmeter with a cassette loaded at playback mode. The measurement value may vary depending on the measuring instruments used or on the product. Bias circuit DC voltage is measured while in the record mode.

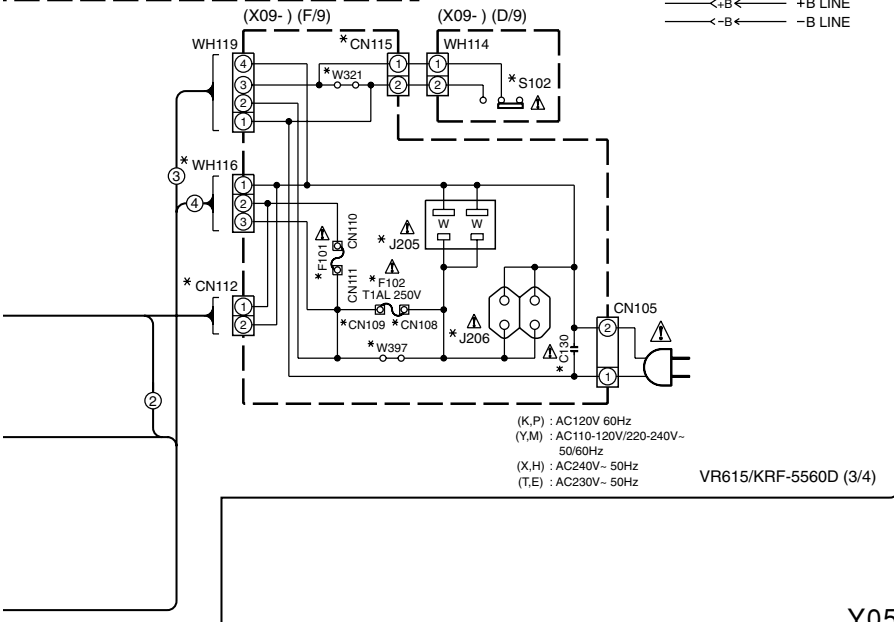
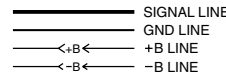

- (K,P) : AC120V 60Hz
- (Y,M) : AC110-120V/220-240V-50/60Hz
- (X,H) : AC240V- 50Hz
- (T,E) : AC230V- 50Hz

VR615/KRF-5560D (3/4)

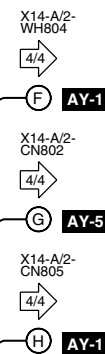

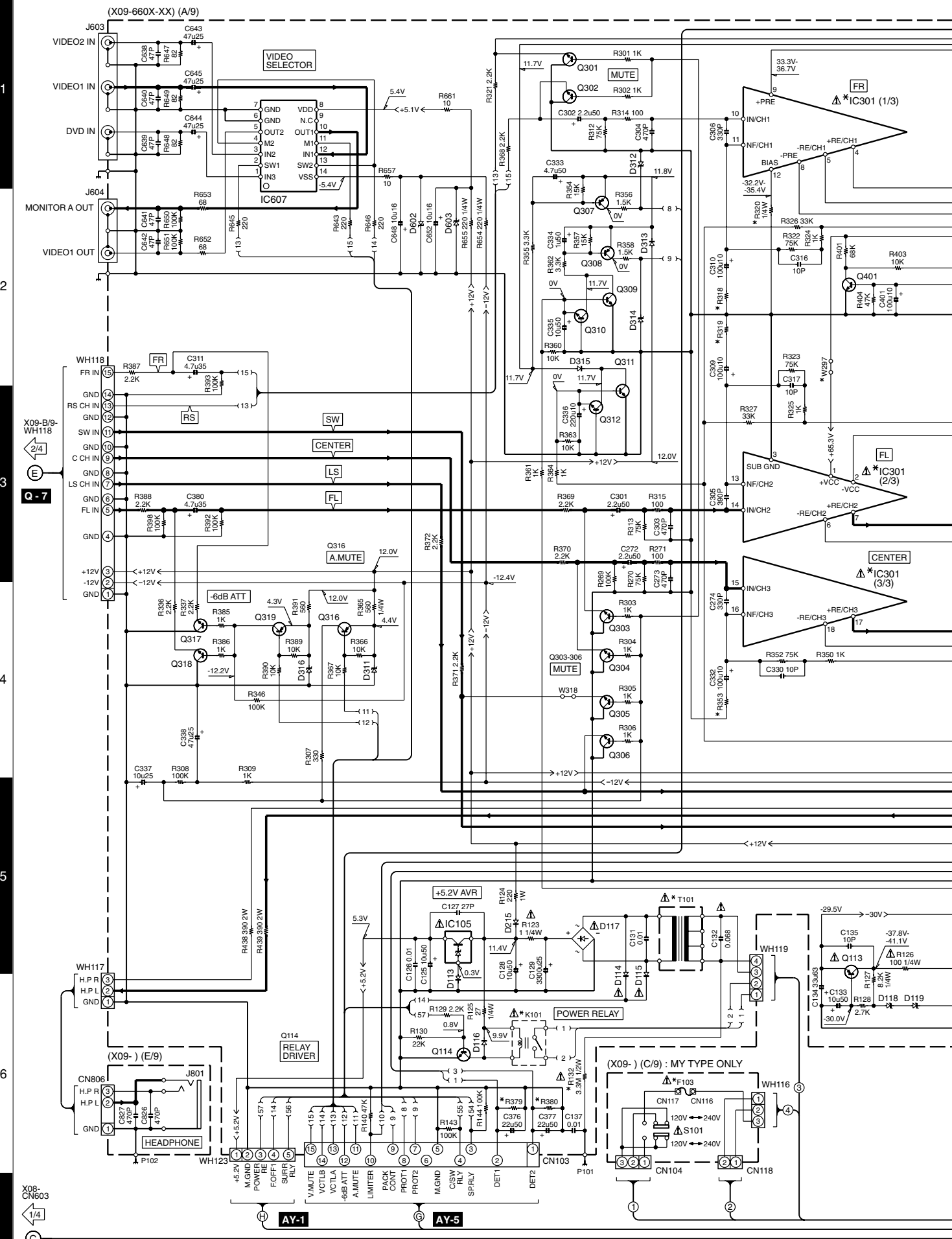

X08-CN603
1/4
C

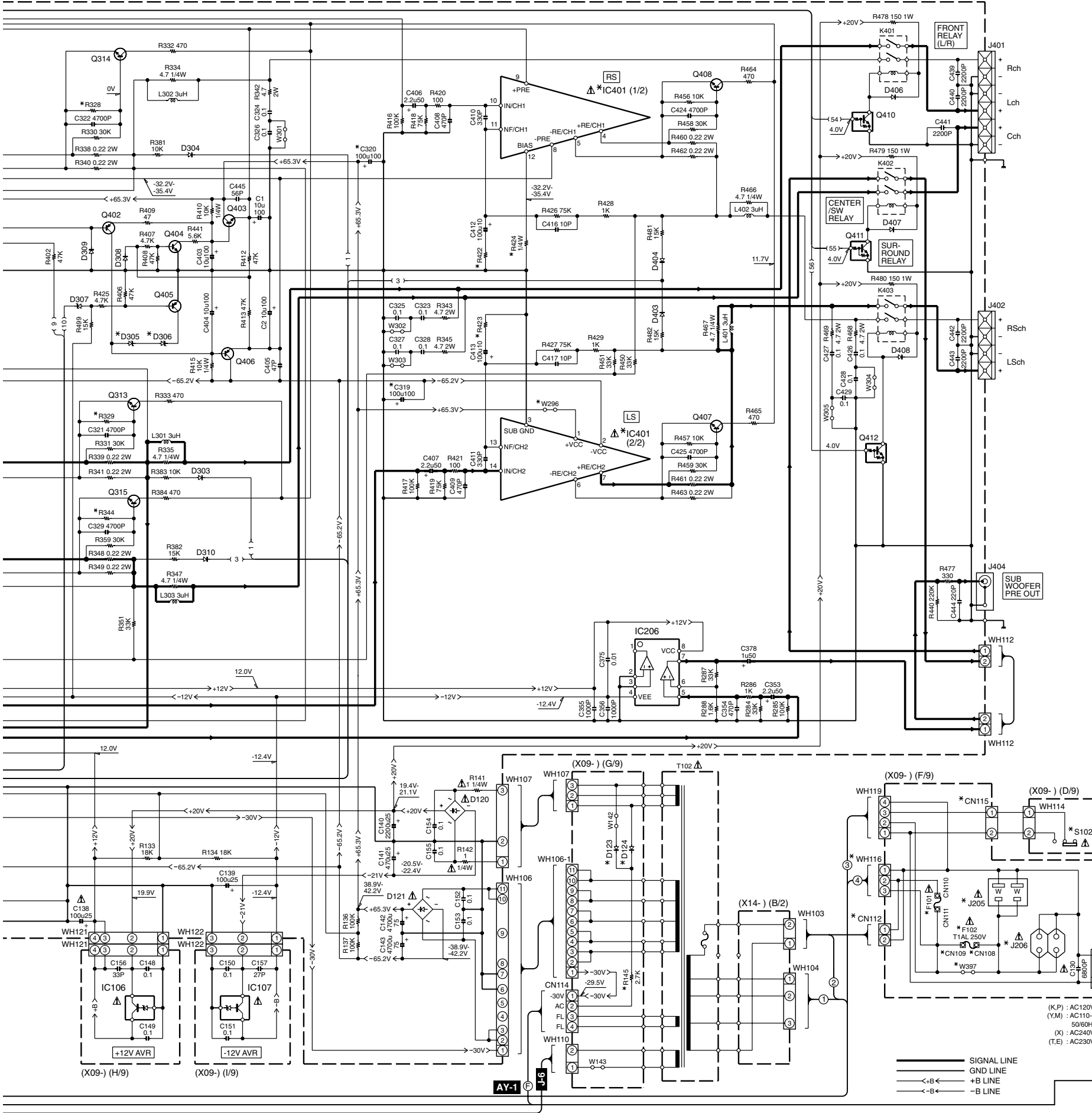

KRF-V4060D (X09-660X-XX)

UNIT	C319	CN108	D123	D305	F101	F102	F103	IC301	IC401	J205	J206	K101	R132	R318,319	R320	R328,329	R379	S102	T101	W296	W397	
DESTINATION	NO	NO	NO	NO	NO	NO	NO	NO	NO	NO	NO	NO	NO	NO	NO	NO	NO	NO	NO	NO	NO	NO
COUNTRY	320	109,115	124	306	MTZJ10(B) or T2.5AL	YES	NO	STK443-070	STK442-070	NO	NO	NO	NO	NO	NO	NO	NO	NO	NO	NO	NO	NO
U.K.	2-72	NO	YES	NO	HZS10N(B2)	250V	NO	NO	NO	NO	NO	NO	NO	NO	NO	NO	NO	NO	NO	NO	NO	NO

KRF-V4060D-S (X09-660X-XX)

UNIT	C319	CN108	D123	D305	F101	F102	F103	IC301	IC401	J205	J206	K101	R132	R318,319	R320	R328,329	R379	S102	T101	W296	W397	
DESTINATION	NO	NO	NO	NO	NO	NO	NO	NO	NO	NO	NO	NO	NO	NO	NO	NO	NO	NO	NO	NO	NO	NO
COUNTRY	320	109,115	124	306	MTZJ10(B) or T2.5AL	YES	NO	STK443-070	STK442-070	NO	NO	NO	NO	NO	NO	NO	NO	NO	NO	NO	NO	NO
U.K.	2-72	NO	YES	NO	HZS10N(B2)	250V	NO	NO	NO	NO	NO	NO	NO	NO	NO	NO	NO	NO	NO	NO	NO	NO

KRF-V4060DE-S (X09-6602-72)

UNIT	C319	CN108	D123	D305	F101	F102	F103	IC301	IC401	J205	J206	K101	R132	R318,319	R320	R328,329	R379	S102	T101	W296	W397	
DESTINATION	NO	NO	NO	NO	NO	NO	NO	NO	NO	NO	NO	NO	NO	NO	NO	NO	NO	NO	NO	NO	NO	NO
COUNTRY	320	109,115	124	306	MTZJ10(B) or T2.5AL	YES	NO	STK443-070	STK442-070	NO	NO	NO	NO	NO	NO	NO	NO	NO	NO	NO	NO	NO
U.K.	2-72	NO	YES	NO	HZS10N(B2)	250V	NO	NO	NO	NO	NO	NO	NO	NO	NO	NO	NO	NO	NO	NO	NO	NO

VR-605 (X09-6600-10)

UNIT	C319	CN108	D123	D305	F101	F102	F103	IC301	IC401	J205	J206	K101	R132	R318,319	R320	R328,329	R379	S102	T101	W296	W397	
DESTINATION	NO	NO	NO	NO	NO	NO	NO	NO	NO	NO	NO	NO	NO	NO	NO	NO	NO	NO	NO	NO	NO	NO
COUNTRY	320	109,115	124	306	MTZJ10(B) or T2.5AL	YES	NO	STK443-070	STK442-070	NO	NO	NO	NO	NO	NO	NO	NO	NO	NO	NO	NO	NO
U.S.A.	0-10	YES	NO	NO	MTZJ10(B) or T2.5AL	NO	NO	STK413-200A or STK413-200A	STK412-020A	NO	NO	NO	NO	NO	NO	NO	NO	NO	NO	NO	NO	NO
CANADA	P	NO	NO	NO	HZS10N(B2)	250V	NO	NO	NO	NO	NO	NO	NO	NO	NO	NO	NO	NO	NO	NO	NO	NO

KRF-V5060D (X09-660X-XX)

UNIT	C319	CN108	D123	D305	F101	F102	F103	IC301	IC401	J205	J206	K101	R132	R318,319	R320	R328,329	R379	S102	T101	W296	W397	
DESTINATION	NO	NO	NO	NO	NO	NO	NO	NO	NO	NO	NO	NO	NO	NO	NO	NO	NO	NO	NO	NO	NO	NO
COUNTRY	320	109,115	124	306	MTZJ10(B) or T2.5AL	YES	NO	STK443-070	STK442-070	NO	NO	NO	NO	NO	NO	NO	NO	NO	NO	NO	NO	NO
U.S.A.	0-10	YES	NO	NO	MTZJ10(B) or T2.5AL	NO	NO	STK413-200A or STK413-200A	STK412-020A	NO	NO	NO	NO	NO	NO	NO	NO	NO	NO	NO	NO	NO
CANADA	P	NO	NO	NO	HZS10N(B2)	250V	NO	NO	NO	NO	NO	NO	NO	NO	NO	NO	NO	NO	NO	NO	NO	NO

KRF-V5060D-S (X09-6602-71)

UNIT	C319	CN108	D123	D305	F101	F102	F103	IC301	IC401	J205	J206	K101	R132	R318,319	R320	R328,329	R379	S102	T101	W296	W397	
DESTINATION	NO	NO	NO	NO	NO	NO	NO	NO	NO	NO	NO	NO	NO	NO	NO	NO	NO	NO	NO	NO	NO	NO
COUNTRY	320	109,115	124	306	MTZJ10(B) or T2.5AL	YES	NO	STK443-070	STK442-070	NO	NO	NO	NO	NO	NO	NO	NO	NO	NO	NO	NO	NO
U.S.A.	0-10	YES	NO	NO	MTZJ10(B) or T2.5AL	NO	NO	STK413-200A or STK413-200A	STK412-020A	NO	NO	NO	NO	NO	NO	NO	NO	NO	NO	NO	NO	NO
CANADA	P	NO	NO	NO	HZS10N(B2)	250V	NO	NO	NO	NO	NO	NO	NO	NO	NO	NO	NO	NO	NO	NO	NO	NO

KRF-V5060D-S (X09-660X-XX)

UNIT	C319	CN108	D123	D305	F101	F102	F103	IC301	IC401	J205	J206	K101	R132	R318,319	R320	R328,329	R379	S102	T101	W296	W397	
DESTINATION	NO	NO	NO	NO	NO	NO	NO	NO	NO	NO	NO	NO	NO	NO	NO	NO	NO	NO	NO	NO	NO	NO
COUNTRY	320	109,115	124	306	MTZJ10(B) or T2.5AL	YES	NO	STK443-070	STK442-070	NO	NO	NO	NO	NO	NO	NO	NO	NO	NO	NO	NO	NO
U.S.A.	0-10	YES	NO	NO	MTZJ10(B) or T2.5AL	NO	NO	STK413-200A or STK413-200A	STK412-020A	NO	NO	NO	NO	NO	NO	NO	NO	NO	NO	NO	NO	NO
CANADA	P	NO	NO	NO	HZS10N(B2)	250V	NO	NO	NO	NO	NO	NO	NO	NO	NO	NO	NO	NO	NO	NO	NO	NO

- IC105 : BA05T
- IC106 : KIA7812API
- IC107 : KIA7912PI
- IC206 : NJM4565D
- IC301 : S1S133 or S1S133 or S1S133
- IC401 : S1S104A
- IC607 : NJM2279D

- D113 : RB441Q-40
- D114-116,123,124,215,303,304,308-310,313,315,403,404,406-408,409 : S1S133 or S1S133 or S1S133
- D117 : S1ZB20(4101)
- D118 : MTZJ16(B) or HZS16N(B2)
- D119,401 : MTZJ15(B) or HZS15N(B2)
- D120 : HZS15N(F,E)
- D121 : DS5BA20F03
- D305,306 : * DS5BA20F03
- D307,311,312,314,316 : S1S133 or S1S133 or S1S133
- D602,603 : * MTZJ3.9(B) or HZS3.9N(B2)

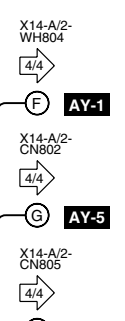

CAUTION: For continued safety, replace safety critical components only with manufacturer's recommended parts (refer to parts list). Δ indicates safety critical components. For continued protection against risk of fire, replace only with same type and rating fuse(s). To reduce the risk of electric shock, leakage-current or resistance measurements shall be carried out (exposed parts are acceptably insulated from the supply circuit) before the appliance is returned to the customer.

The DC voltage is an actual reading measured with a high impedance type voltmeter with a cassette loaded at playback mode. The measurement value may vary depending on the measuring instruments used or on the product. Bias circuit DC voltage is measured while in the record mode.

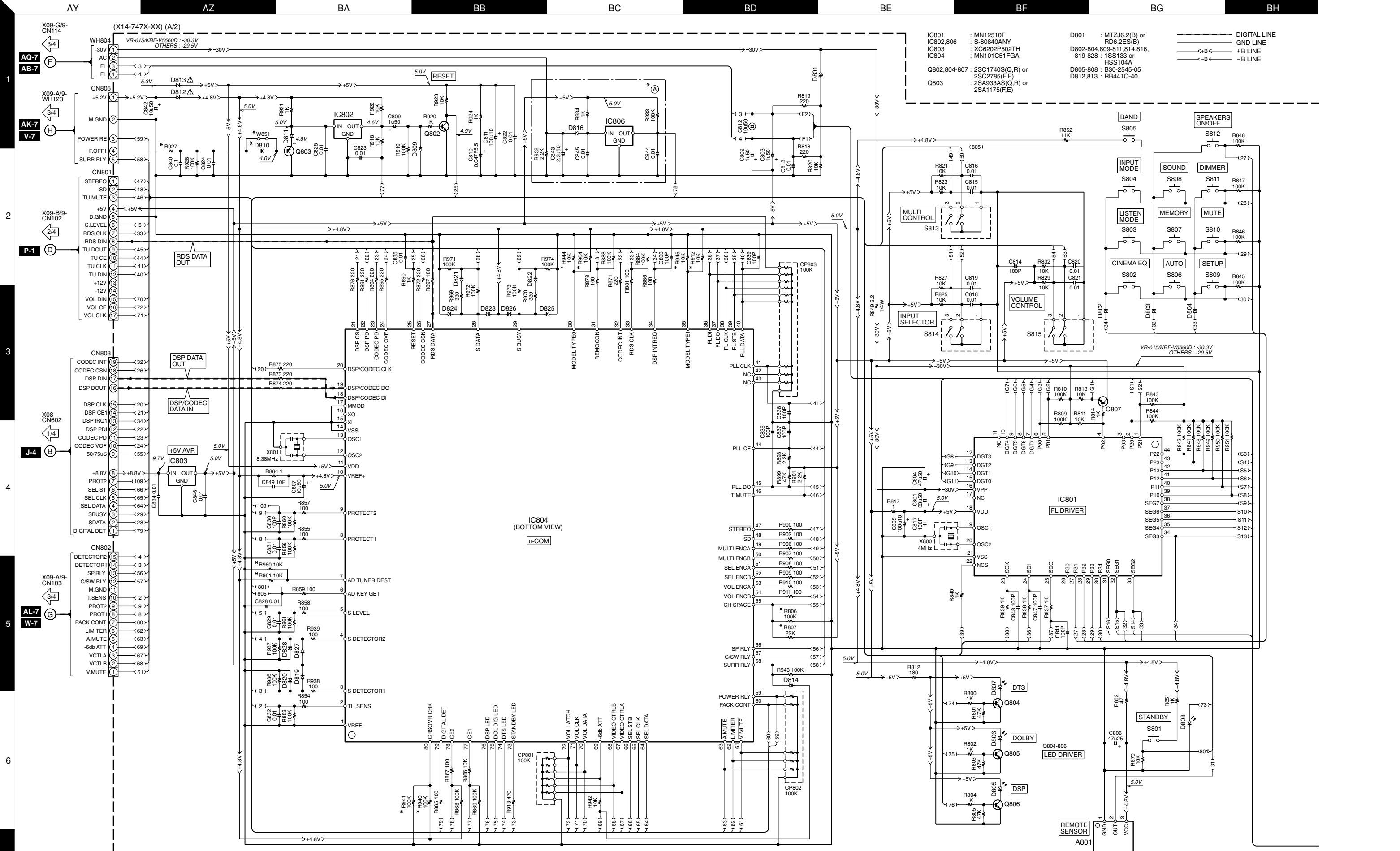

- | | | |
|--|--|--------------|
| IC801 : MN12510F | D801 : MTZJ6.2(B) or RD6.2ES(B) | DIGITAL LINE |
| IC802,806 : S-80840ANY | D802-804,809-811,814,816,819-828 : 1SS133 or HSS104A | GND LINE |
| IC803 : XC6202P502TH | D805-808 : B30-2545-05 | ←+B← +B LINE |
| IC804 : MN101C51FGA | D812,813 : RB441Q-40 | ←-B← -B LINE |
| Q802,804-807 : 2SC1740S(Q,R) or 2SC2785(F,E) | | |
| Q803 : 2SA933AS(Q,R) or 2SA1175(F,E) | | |

- AY** X09-G/9-CN114
- AZ** (X14-747X-XX) (A/2)
- BA** VR-615/KRF-V5560D : -30.3V
OTHERS : -29.5V
- BB** WH804
- BC** AC 30V
- BD** 5.0V
- BE** 5.0V
- BF** 5.0V
- BG** 5.0V
- BH** 5.0V
- 1** AQ-7 AB-7
- 2** AK-7 V-7
- 3** P-1
- 4** J-4
- 5** AL-7 W-7
- 6**
- 7**
- 8**
- 9**
- 10**
- 11**
- 12**
- 13**
- 14**
- 15**
- 16**
- 17**
- 18**
- 19**
- 20**
- 21**
- 22**
- 23**
- 24**
- 25**
- 26**
- 27**
- 28**
- 29**
- 30**
- 31**
- 32**
- 33**
- 34**
- 35**
- 36**
- 37**
- 38**
- 39**
- 40**
- 41**
- 42**
- 43**
- 44**
- 45**
- 46**
- 47**
- 48**
- 49**
- 50**
- 51**
- 52**
- 53**
- 54**
- 55**
- 56**
- 57**
- 58**
- 59**
- 60**
- 61**
- 62**
- 63**
- 64**
- 65**
- 66**
- 67**
- 68**
- 69**
- 70**
- 71**
- 72**
- 73**
- 74**
- 75**
- 76**
- 77**
- 78**
- 79**
- 80**
- 81**
- 82**
- 83**
- 84**
- 85**
- 86**
- 87**
- 88**
- 89**
- 90**
- 91**
- 92**
- 93**
- 94**
- 95**
- 96**
- 97**
- 98**
- 99**
- 100**

(X14-747X-XX) (A/2)

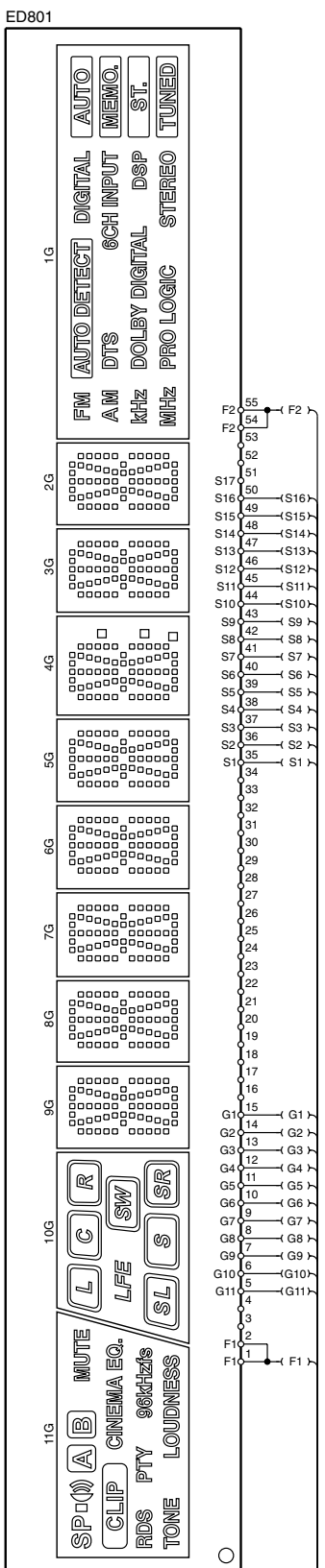

VR-605/615/KRF-V4060D/5060D/5560D (4/4)

KRF-V4060D (X14-7472-73)

DESTINATION	UNIT	(A)	D810	R806, 904, 941, 945, 961	R807, 866, 912, 940, 944, 960	R927	W851
COUNTRY	ABB. No.						
EUROPE	E		NO	NO	YES	NO	160K YES
U.K.	T	2-73					

KRF-V4060D-S (X14-747X-XX)

DESTINATION	UNIT	(A)	D810	R806, 940	R807, 866	R904, 941, 945, 961	R912, 944	R927	R960	W851
COUNTRY	ABB. No.									
GENERAL MARKET	M	0-23	YES	YES	NO	YES				NO
AUSTRALIA	X	0-73						62K 180K	YES	
EUROPE	E3		NO	NO	YES	NO	NO	160K	NO	YES
U.K.	T1	2-73								

KRF-V4060DE (X14-7472-73)

DESTINATION	UNIT	(A)	D810	R806, 904, 941, 945, 961	R807, 866, 912, 940, 944, 960	R927	W851
COUNTRY	ABB. No.						
EUROPE	E1	2-73	NO	NO	YES	NO	160K YES

KRF-V4060DE-S (X14-7472-73)

DESTINATION	UNIT	(A)	D810	R806, 904, 941, 945, 961	R807, 866, 912, 940, 944, 960	R927	W851
COUNTRY	ABB. No.						
EUROPE	E2	2-73	NO	NO	YES	NO	160K YES

VR605 (X14-7470-10)

DESTINATION	UNIT	(A)	D810	R806, 904, 941, 945, 960	R807, 866, 912, 940, 944, 960	R927	W851
COUNTRY	ABB. No.						
U.S.A	K	0-10	NO	YES	YES	NO	56K NO
CANADA	P						

KRF-V5060D (X14-747X-XX)

DESTINATION	UNIT	(A)	D810	R806, 945	R807, 866, 912, 960	R904, 940	R927	R941, 944, 961	W851
COUNTRY	ABB. No.								
PX	Y	0-21	YES	YES	NO	YES		62K	NO
EUROPE	E	2-71	NO	NO	YES	NO	NO	160K	YES
U.K.	T								YES

KRF-V5060D-S (X14-747X-XX)

DESTINATION	UNIT	(A)	D810	R806	R807, 866	R904, 940	R912	R927	R941, 944, 961	R945	R960	W851
COUNTRY	ABB. No.											
GENERAL MARKET	M	0-21	YES	YES	NO	YES			62K	NO	YES	NO
AUSTRALIA	X	0-71					YES		180K			
EUROPE	E3		NO	NO	YES	NO	NO	NO	160K	YES	NO	YES
U.K.	T1	2-71										

KRF-V5060DE (X14-7472-71)

DESTINATION	UNIT	(A)	D810	R806, 941, 944, 945, 961	R807, 866, 904, 912, 940, 960	R927	W851
COUNTRY	ABB. No.						
EUROPE	E1	2-71	NO	NO	YES	NO	160K YES

VR-615 (X14-7470-11)

DESTINATION	UNIT	(A)	D810	R806, 912, 940, 944, 960	R807, 866, 904, 941, 945, 961	R927	W851
COUNTRY	ABB. No.						
U.S.A	K	0-11	NO	YES	YES	NO	56K NO
CANADA	P						

KRF-V5560D (X14-747X-XX)

DESTINATION	UNIT	(A)	D810	R806	R807, 866, 960	R904, 941, 945, 961	R912, 940, 944	R927	W851
COUNTRY	ABB. No.								
PX	Y	0-22	YES	YES	NO	YES	NO		62K NO
EUROPE	E	2-72	NO	NO	YES	NO	NO	160K	YES

KRF-V5560D-S (X14-747X-XX)

DESTINATION	UNIT	(A)	D810	R806	R807, 866	R904, 941, 945, 961	R912, 940, 944	R927	R960	W851
COUNTRY	ABB. No.									
GENERAL MARKET	M	0-22	YES	YES	NO	YES				NO
AUSTRALIA	X	0-72								62K NO
EUROPE	E3		NO	NO	YES	NO	NO	NO	160K	NO YES
U.K.	T1	2-72								
KOREA	H									

	11G	10G	9G	8G	7G	6G	5G	4G	3G	2G	1G
P1	SP(1)	L	a	a	a	a	a	a	a	a	FM
P2	(A)	C	j	j	j	j	j	j	j	j	AM
P3	(B)	R	h	h	h	h	h	h	h	h	MHz
P4	MUTE	SL	k	k	k	k	k	k	k	k	kHz
P5	CLIP	S	b	b	b	b	b	b	b	b	AUTO
P6	CINEMA EQ.	SR	f	f	f	f	f	f	f	f	MEMO.
P7	-	LFE	g	g	g	g	g	g	g	g	ST.
P8	-	SW	m	m	m	m	m	m	m	m	TUNED
P9	RDS	(L)	c	c	c	c	c	c	c	c	AUTO DETECT
P10	PTY	(C)	e	e	e	e	e	e	e	e	DTS
P11	96kHz	(R)	r	r	r	r	r	r	r	r	DOLBY DIGITAL
P12	TONE	(SL)	n	n	n	n	n	n	n	n	PRO LOGIC
P13	LOUDNESS	(S)	p	p	p	p	p	p	p	p	DIGITAL
P14	-	(SR)	d	d	d	d	d	d	d	d	6CH INPUT
P15	-	(SW)	-	-	-	-	-	-	-	-	DSP
P16	-	-	-	-	-	-	-	-	-	-	STEREO

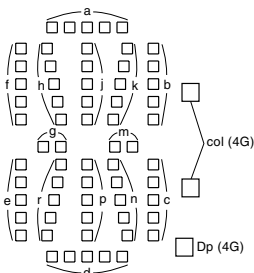

CAUTION: For continued safety, replace safety critical components only with manufacturer's recommended parts (refer to parts list). Δ indicates safety critical components. For continued protection against risk of fire, replace only with same type and rating fuse(s). To reduce the risk of electric shock, leakage-current or resistance measurements shall be carried out (exposed parts are acceptably insulated from the supply circuit) before the appliance is returned to the customer.

The DC voltage is an actual reading measured with a high impedance type voltmeter with a cassette loaded at playback mode. The measurement value may vary depending on the measuring instruments used or on the product. Bias circuit DC voltage is measured while in the record mode.

KRF-V4060D/V5060D/V5560D/VR-605/615