

**KRF-V7070D/V7070D-S/V8070D
KRF-V8070D-S/X9070D/X9070D-S
VR-7060/7070/7080
SERVICE MANUAL**

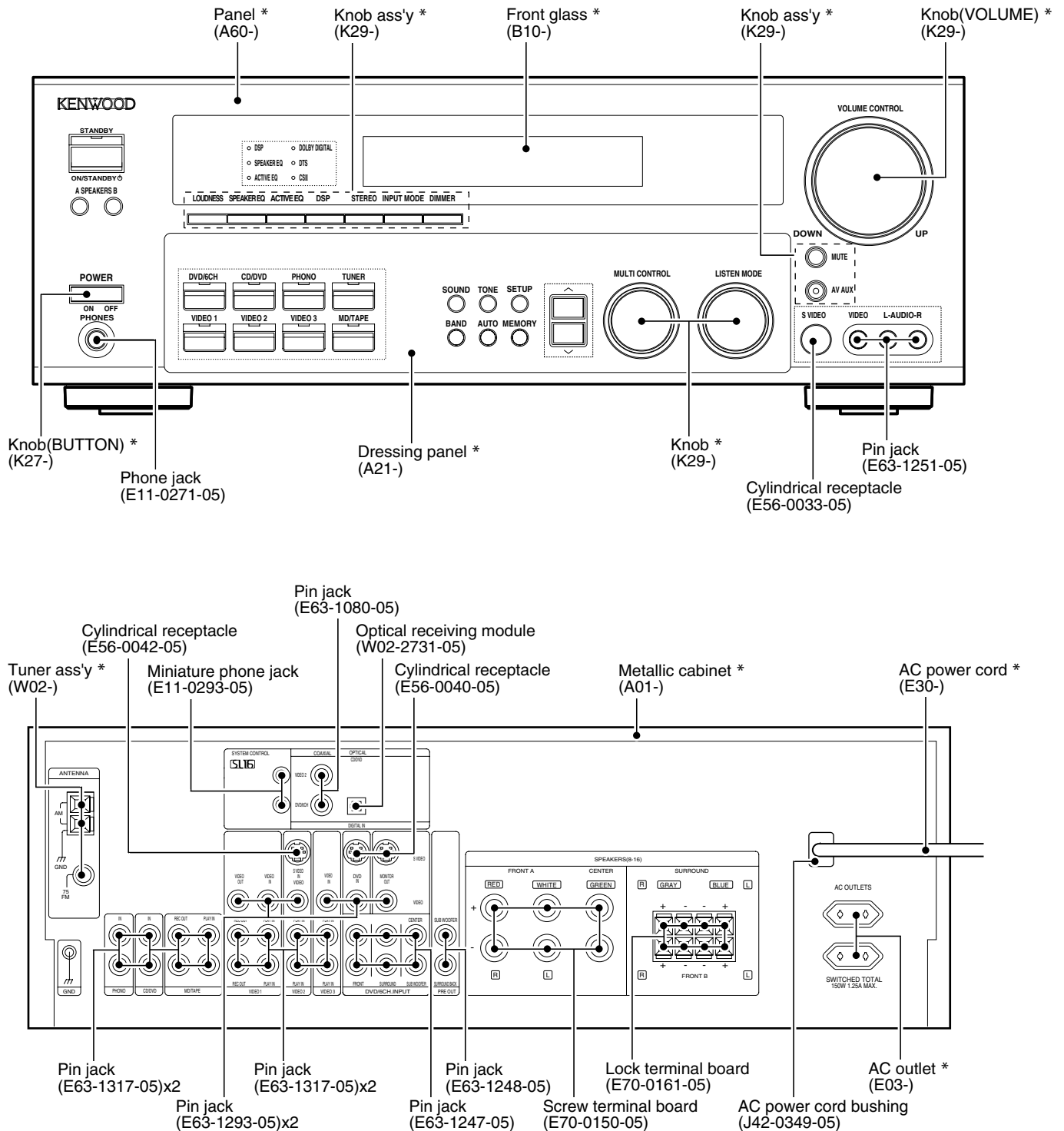

Illust. is KRF-V7070D.

* Refer to parts list on page 29 .



KRF-V7070D/V8070D/X9070D/VR-7060/7070/7080

ACCESSORIES / CAUTIONS

Accessories

FM indoor antenna (1)
(T90-0877-05)



AM loop antenna (1)
(T90-0893-05)

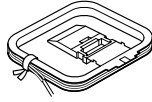

RF remote antenna (1)
Refer to the table on this page below.

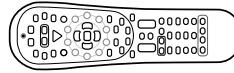

Batteries (R6/AA) (2)

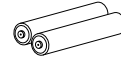

There is a different shape of remote control in every area.

REMOTE CONTROL vs MODEL

MODEL	ABBRI.	PARTS #	BATTERY COVER
KRF-V7070D	E7	A70-1623-05	A09-1274-08
KRF-V7070D-S	E1	A70-1623-05	A09-1274-08
VR-7060	K6	A70-1622-05	A09-1274-08
VR-7060	P6	A70-1622-05	A09-1274-08
KRF-V8070D	E8	A70-1623-05	A09-1274-08
KRF-V8070D-S	E2	A70-1623-05	A09-1274-08
KRF-X9070D	Y1	A70-1619-05	A09-1275-08
KRF-X9070D	E9	A70-1621-05	A09-1274-08
KRF-X9070D-S	E3	A70-1621-05	A09-1274-08
VR-7070	K7	A70-1620-05	A09-1274-08
VR-7070	P7	A70-1620-05	A09-1274-08
VR-7080	K8	A70-1619-05	A09-1275-08
VR-7080	P8	A70-1619-05	A09-1275-08

Cautions

Resetting the Microcomputer

The microcomputer may malfunction (unit cannot be operated, or shows an erroneous display) if the power cord is unplugged while the power is ON, or due to some other external factor. If this happens, execute the following procedure to reset the microcomputer and return the unit to its normal operating condition.

- Please note that resetting the microcomputer will clear the contents of the memory and returns the unit to the state it was in when it left the factory.

Unplug the power cord from the wall outlet, then plug it back in while holding down the POWER ON/STANDBY ϕ key.

Memory back up function

Please note that the following items will be deleted from the unit's memory if the power cord is disconnected from the AC outlet for approximately 1 day.

- Power mode.
- Input selector settings.
- Picture output.
- Speaker ON/OFF.
- Volume level.
- BASS, TREBLE, INPUT level.
- TONE ON/OFF.
- LOUDNESS ON/OFF.
- Dimmer level.
- MD/TAPE settings.
- Listen mode setting.
- Speaker settings.
- SW RE-MIX ON/OFF.
- Distance setting.
- Bass peak level.
- Input mode setting.
- Midnight mode setting.
- PRO LOGIC II mode setting.
- CS II mode setting.
- Broadcast band.
- Frequency setting.
- Preset stations.
- Tuning mode.
- THX mode.
- DSP mode.
- ACTIVE EQ mode.
- SPEAKER EQ mode.

EXTERNAL VIEW / ADJUSTMENT

EXTERNAL VIEW

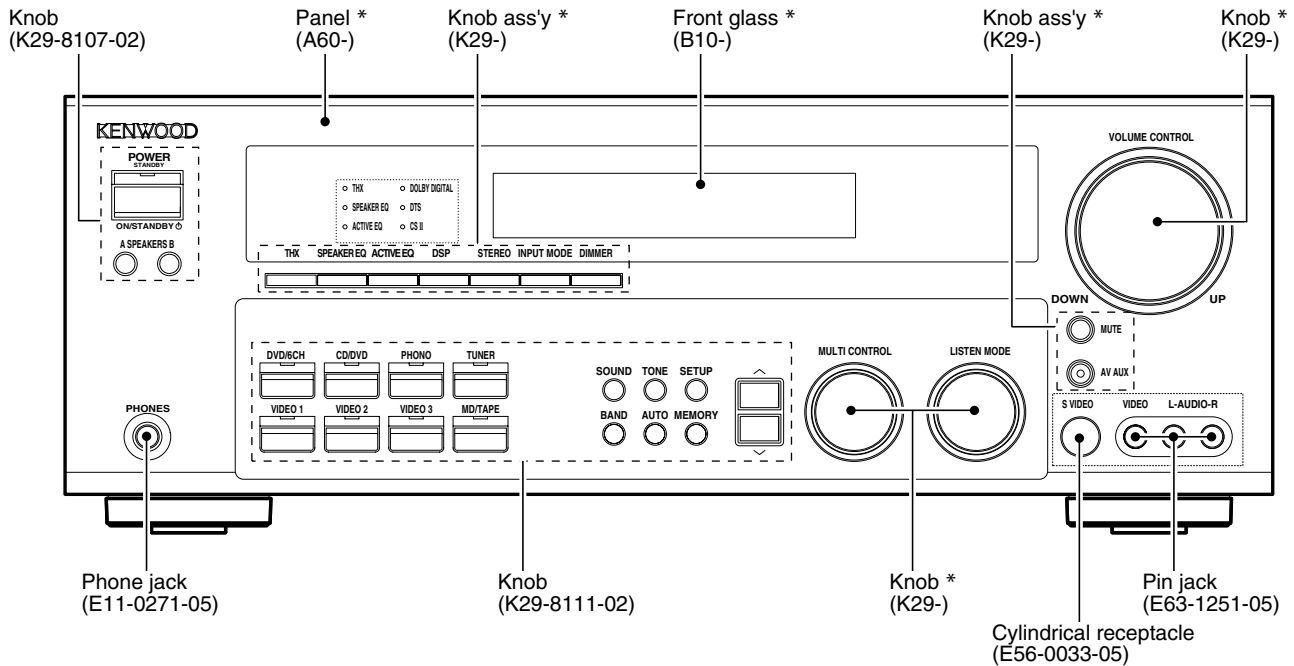

Illust. is VR-7060.

* Refer to parts list on page 29 .

ADJUSTMENT

No.	ITEM	INPUT SETTINGS	OUTPUT SETTINGS	RECEIVER SETTINGS	ALIGNMENT POINTS	ALIGN FOR	FIG.
AUDIO SECTION		SPEAKER : A					
<1>	IDLE CURRENT	-	CN11, FL ch. CN10, FR ch. CN14, SL ch. CN13, SR ch. CN12, C ch. CN15, SW ch. X09(A/5)	(FRONT 2ch MODE) Volume: Minimum	VR1(FL) VR2(FR) VR3(SL) VR4(SR) VR5(CENTER) VR6(SUB WOOFER) X09(A/5)	Adjust every potentiometer 10 minutes later after turned the power on.	

Idling Current Adjustment

All power amplifier stage need idling current adjustment after the installation of TRAIT transistor.

1. Connect a voltmeter to CN11 with the correct polarity as indicated by the PCB silk print.
2. Adjust the preset, VR1 to get 8.8mV (Idling current = 20mA) at the voltmeter reading.
3. Repeat step 1 and 2 for all other channels.

INTERCONNECTION DIAGRAM

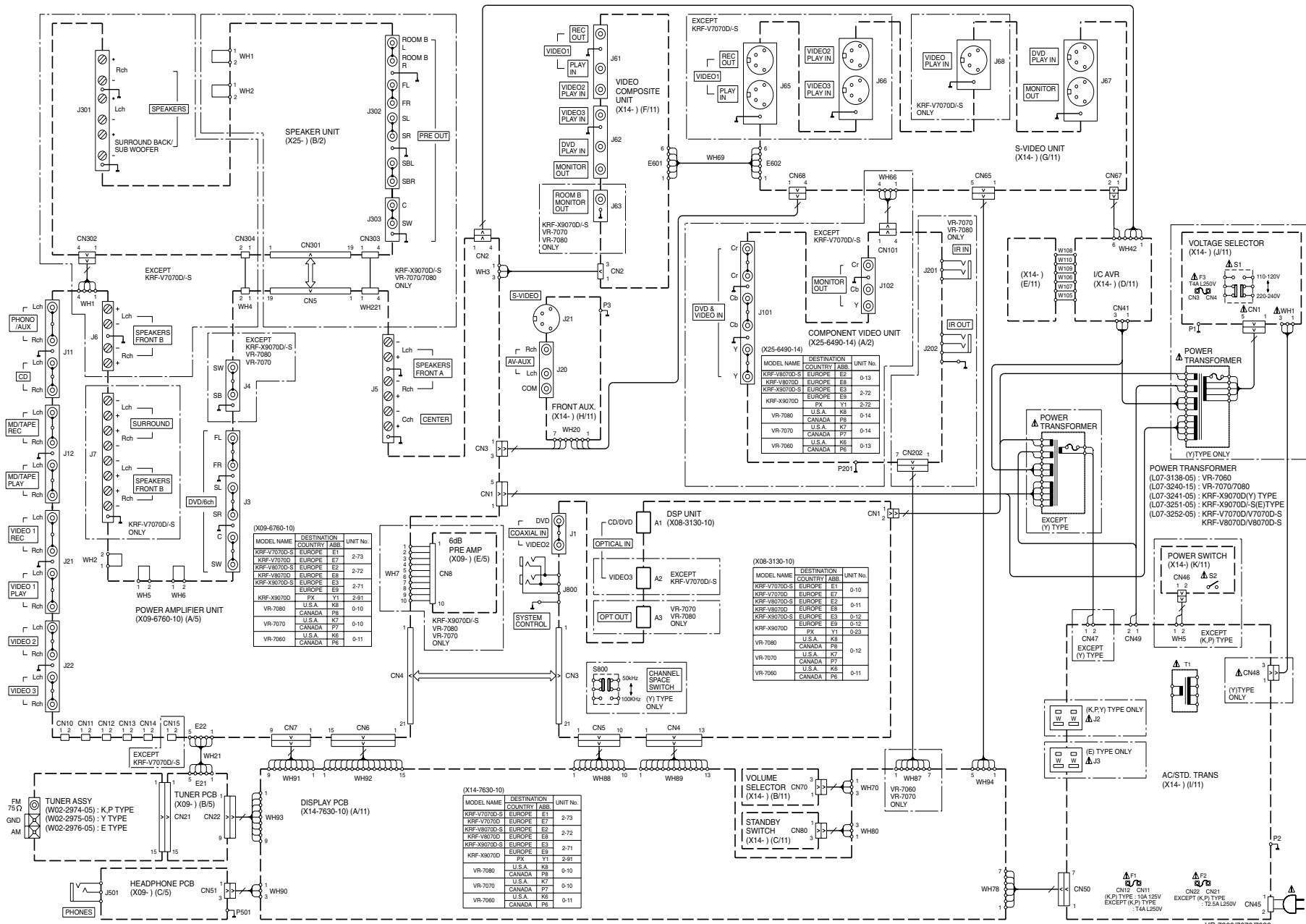

KRF-X9070D-S, KRF-V8070D-D, S, KRF-V7070D-D, S, KRF-V7070D-D, S

PC BOARD (Component side view)

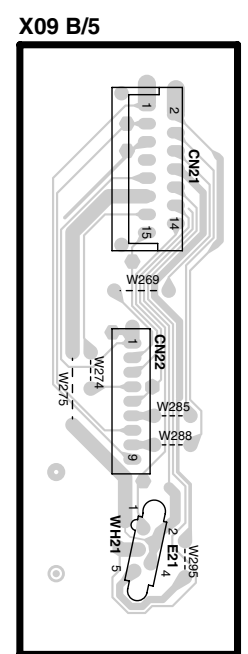
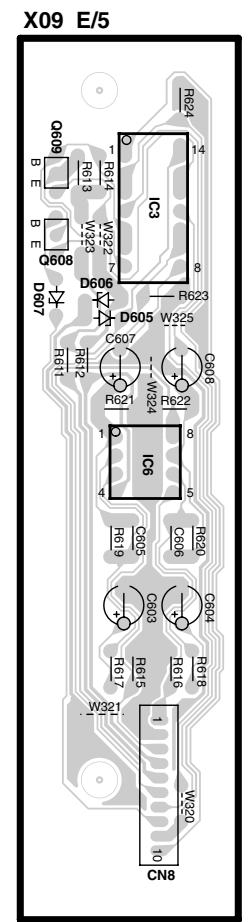
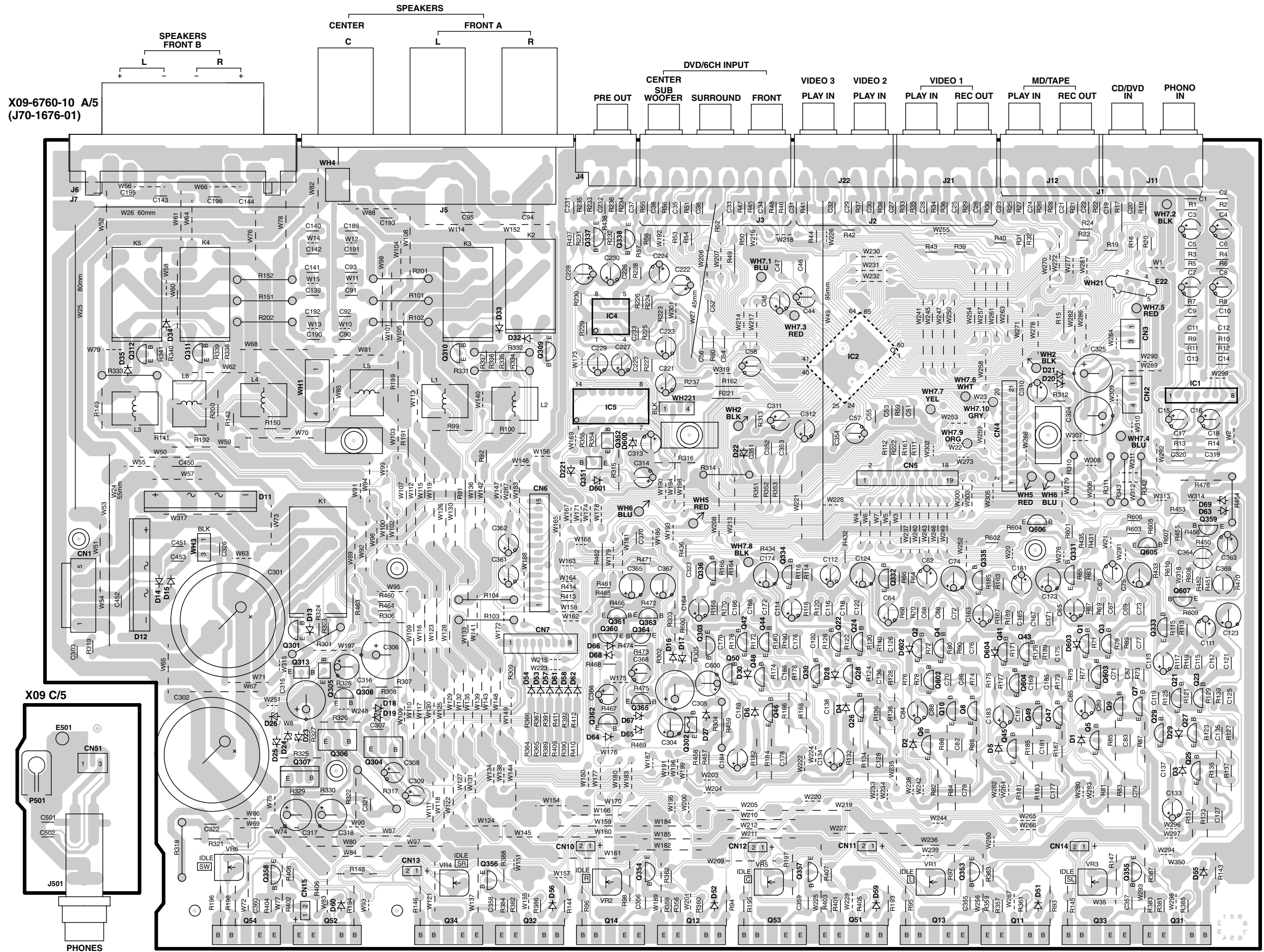

X09-6760-10 A/5
(J70-1676-01)

X09 C/5

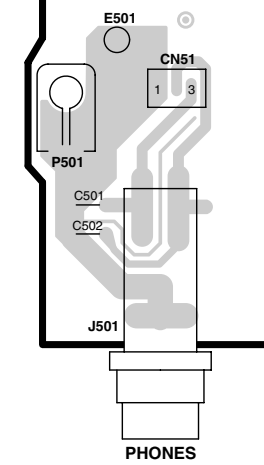

PHONES

Refer to the schematic diagram for the value of resistors and capacitors.

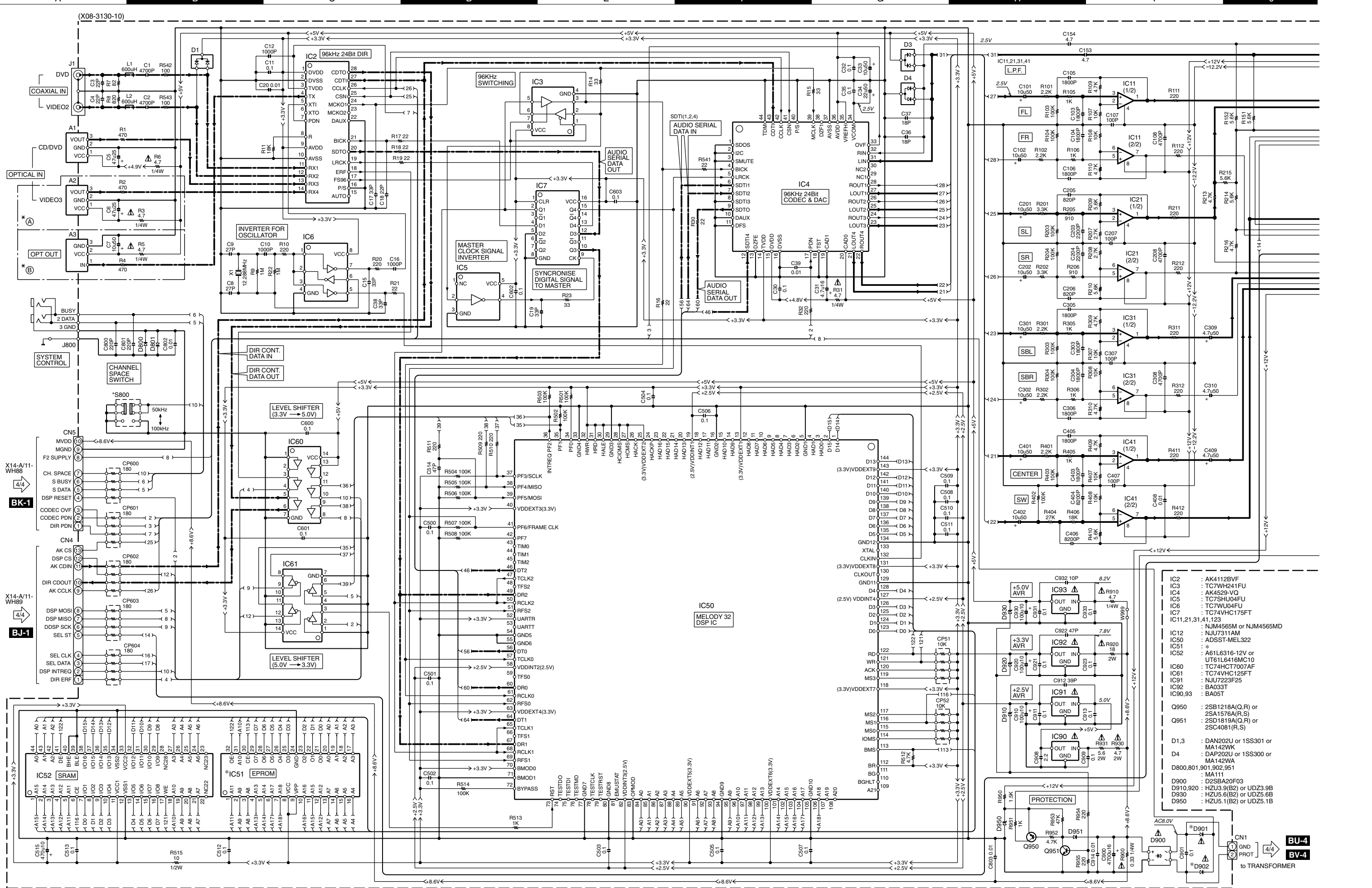

- IC1 : AK4112BVF
- IC2 : TC7WH241FU
- IC3 : AK4529-V0
- IC4 : TC7SHU04FU
- IC5 : TC7WU04FU
- IC6 : TC74VHC175FT
- IC7 : TC74VHC1.25FT
- IC8 : NJM4565M or NJM4565MD
- IC9 : NJU7311AM
- IC10 : ADSS1-MEL322
- IC11 : *
- IC12 : A61L6316-12V or UT51L6416MC10
- IC13 : TC74HC1700AF
- IC14 : TC74VHC125FT
- IC15 : NJU7223F25
- IC16 : BA03T
- IC17 : BA05T
- IC18 : 2SB1218A(Q,R) or 2SA1576A(R,S)
- IC19 : 2SD1819A(Q,R) or 2SC4081(R,S)
- IC20 : DAN202U or 1SS301 or MA142WK
- IC21 : DAP202U or 1SS300 or MA142WA
- IC22 : MA111
- IC23 : D2SBA20F03
- IC24 : HZU3.9(B2) or UDZ3.9B
- IC25 : HZU5.6(B2) or UDZ5.6B
- IC26 : HZU5.1(B2) or UDZ5.1B

X14-A/11-WH88
BK-1

X14-A/11-WH89
BJ-1

BU-4
BV-4
to TRANSFORMER

(X08-3130-10)

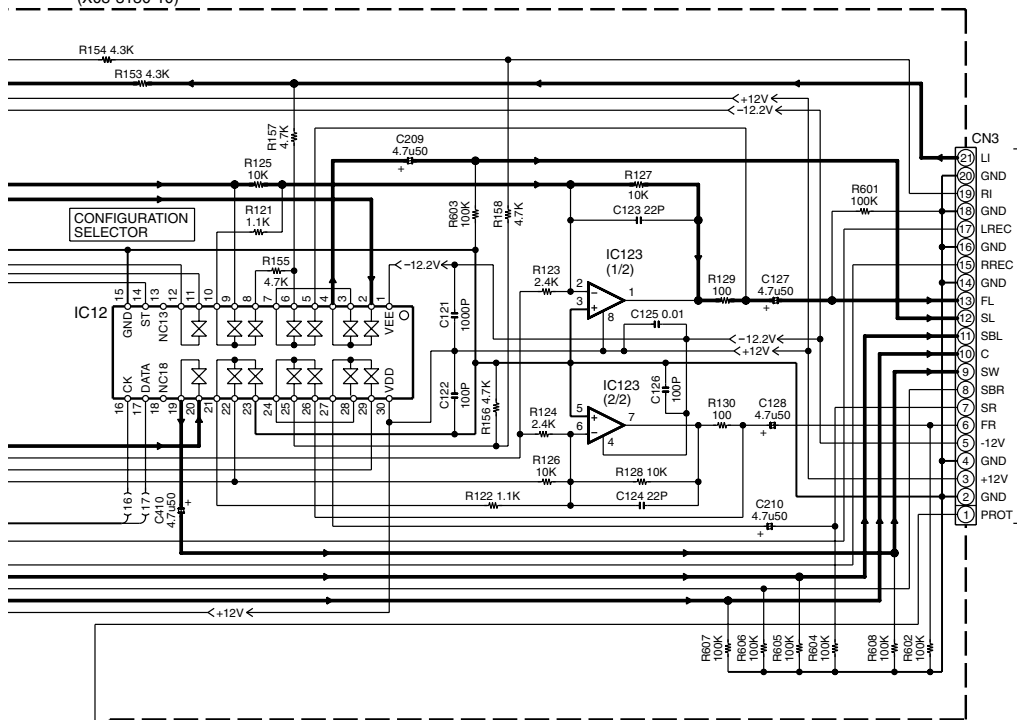

(X08-3130-10)

MODEL NAME	DESTINATION COUNTRY	ABB.	UNIT No.	(A)	(B)	S800	D901, 902	IC51
KRF-V7070D-S	EUROPE	E1	0-10	NO	NO	NO	NO	27W40180N6705
KRF-V7070D	EUROPE	E7						
KRF-V8070D-S	EUROPE	E2	0-11	YES	NO	NO	NO	27W40180N6905
KRF-V8070D	EUROPE	E8						
KRF-X9070D-S	EUROPE	E3	0-12	YES	YES	NO	NO	27W40180N6A05
KRF-X9070D	EUROPE	E9	0-12	YES	YES	NO	NO	27W40180N6A05
	PX	Y1	0-23	YES	YES	YES	YES	27W40180N6A05
VR-7080	U.S.A.	K8						
	CANADA	P8	0-12	YES	YES	NO	NO	27W40180N6A05
VR-7070	U.S.A.	K7						
	CANADA	P7						
VR-7060	U.S.A.	K6	0-11	YES	NO	NO	NO	27W40180N6905
	CANADA	P6						

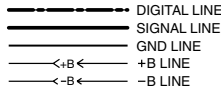

KRF-V7070D/V7070D-S (1/4)
 KRF-V8070D/V8070D-S (1/4)
 KRF-X9070D/X9070D-S (1/4)
 VR-7060/7070/7080 (1/4)

CAUTION: For continued safety, replace safety critical components only with manufacturer's recommended parts (refer to parts list). Δ indicates safety critical components. For continued protection against risk of fire, replace only with same type and rating fuse(s). To reduce the risk of electric shock, leakage-current or resistance measurements shall be carried out (exposed parts are acceptably insulated from the supply circuit) before the appliance is returned to the customer.

The DC voltage is an actual reading measured with a high impedance type voltmeter with no signal input. The measurement value may vary depending on the measuring instruments used or on the product.

KRF-V7070D/V8070D/X9070D/VR-7060/7070/7080

(X09-6760-10)

MODEL NAME	DESTINATION COUNTRY ABB.	UNIT No.	(B)	(D)	(C)	(E)	(F)	C64,65,163	C74,75,173	C82,83,181	C84,85,183	C90,91,139,140,189	C92,93,141,142,191	C143,144	C190	C192	C227,228
KRF-V7070D-S	EUROPE E1	2-73	NO	YES	NO	NO	3.3u50	100u25	YES	22u50	0.22	YES	YES	NO	NO	NO	NO
KRF-V7070D	EUROPE E7																
KRF-V8070D-S	EUROPE E2	2-72	YES	YES	NO	NO	3.3u50	100u25	YES	22u50	0.22	YES	NO	0.22	YES	YES	NO
KRF-V8070D	EUROPE E8																
KRF-X9070D-S	EUROPE E3	2-71	YES	NO	YES	NO	3.3u100	220u10	NO	47u25	0.22	YES	NO	0.22	YES	YES	YES
KRF-X9070D	EUROPE E9																
KRF-X9070D	PX Y1	2-91	YES	NO	YES	NO	3.3u100	220u10	NO	47u25	0.22	YES	NO	0.22	YES	YES	YES
VR-7080	U.S.A. K8 CANADA P8	0-10	YES	NO	YES	NO	3.3u100	220u10	NO	47u25	0.1	NO	NO	0.1	NO	NO	YES
VR-7070	U.S.A. K7 CANADA P7	0-10	YES	NO	YES	NO	3.3u100	220u10	NO	47u25	0.1	NO	NO	0.1	NO	NO	YES
VR-7060	U.S.A. K6 CANADA P6	0-11	YES	YES	NO	NO	3.3u50	100u25	YES	22u50	0.1	NO	NO	0.1	NO	NO	YES

(X09-6760-10)

MODEL NAME	DESTINATION COUNTRY ABB.	UNIT No.	C301,302	C305	C307	C322	C326	C363	C369	C609,610	CN5	CN15	D23	D24
KRF-V7070D-S	EUROPE E1	2-73	4700u75 C90-5772-05	100u63	220P	15P	NO	22u50	33u16	NO	NO	NO	MTZJ10(B) or RD10ES(B)	MTZJ10(B) or RD10ES(B)
KRF-V7070D	EUROPE E7													
KRF-V8070D-S	EUROPE E2	2-72	4700u75 C90-5772-05	100u63	220P	15P	NO	22u50	33u16	NO	NO	YES	MTZJ10(B) or RD10ES(B)	MTZJ10(B) or RD10ES(B)
KRF-V8070D	EUROPE E8													
KRF-X9070D-S	EUROPE E3	2-71	10000u75 C90-5771-05	100u63	180P	12P	YES	47u25	22u25	YES	YES	YES	MTZJ11(B) or RD11ES(B)	MTZJ10(B) or RD10ES(B)
KRF-X9070D	EUROPE E9													
KRF-X9070D	PX Y1	2-91	10000u75 C90-5749-05	100u35	180P	12P	YES	47u25	22u25	NO	YES	YES	MTZJ11(B) or RD11ES(B)	MTZJ7.5(B) or RD7.5ES(B)
VR-7080	U.S.A. K8 CANADA P8	0-10	10000u75 C90-5749-05	100u35	180P	12P	YES	47u25	22u25	NO	YES	YES	MTZJ10(B) or RD10ES(B)	MTZJ15(B) or RD15ES(B)
VR-7070	U.S.A. K7 CANADA P7	0-10	10000u75 C90-5749-05	100u35	180P	12P	YES	47u25	22u25	NO	YES	YES	MTZJ10(B) or RD10ES(B)	MTZJ15(B) or RD15ES(B)
VR-7060	U.S.A. K6 CANADA P6	0-11	4700u75 C90-5775-05	100u35	220P	15P	NO	22u50	33u16	NO	NO	YES	MTZJ10(B) or RD10ES(B)	MTZJ15(B) or RD15ES(B)

(X09-6760-10)

MODEL NAME	DESTINATION COUNTRY ABB.	UNIT No.	D25	D26	J4	J6	J7	K2-5	L6	Q313	R65,66	R79,80,129,130,179	R180	R200,202	R303
KRF-V7070D-S	EUROPE E1	2-73	MTZJ24(B) or RD24ES(B)	NO	YES	NO	YES	S76-0098-05	NO	NO	1.5K	430	NO	NO	1
KRF-V7070D	EUROPE E7														
KRF-V8070D-S	EUROPE E2	2-72	MTZJ24(B) or RD24ES(B)	NO	YES	YES	NO	S76-0098-05	YES	NO	1.5K	430	2K	YES	1
KRF-V8070D	EUROPE E8														
KRF-X9070D-S	EUROPE E3	2-71	MTZJ24(B) or RD24ES(B)	YES	NO	YES	NO	S76-0098-05	YES	YES	2.2K	1.6K	1.6K	YES	1
KRF-X9070D	EUROPE E9														
KRF-X9070D	PX Y1	2-91	MTZJ30(B) or RD30ES(B)	NO	NO	YES	NO	S76-0045-15	YES	NO	2.2K	1.6K	1.6K	YES	560
VR-7080	U.S.A. K8 CANADA P8	0-10	MTZJ24(B) or RD24ES(B)	NO	NO	YES	NO	S76-0045-15	YES	NO	2.2K	1.6K	1.6K	YES	560
VR-7070	U.S.A. K7 CANADA P7	0-10	MTZJ24(B) or RD24ES(B)	NO	NO	YES	NO	S76-0045-15	YES	NO	2.2K	1.6K	1.6K	YES	560
VR-7060	U.S.A. K6 CANADA P6	0-11	MTZJ24(B) or RD24ES(B)	NO	YES	YES	NO	S76-0045-15	YES	NO	1.5K	390	1.6K	YES	1

(X09-6760-10)

MODEL NAME	DESTINATION COUNTRY ABB.	UNIT No.	R304	R317	R318	R358,359,383,384,403	R404	R413,414	R470	R603,604	W3,4	W5-7,20-23	W8	W10-15	WH1,4	WH7,221
KRF-V7070D-S	EUROPE E1	2-73	10K	1.2K	1.5K	10K	NO	1.5K	YES	1.5K	NO	YES	YES	NO	NO	NO
KRF-V7070D	EUROPE E7															
KRF-V8070D-S	EUROPE E2	2-72	10K	1.2K	1.5K	10K	10K	1.5K	YES	1.5K	NO	YES	YES	NO	YES	NO
KRF-V8070D	EUROPE E8															
KRF-X9070D-S	EUROPE E3	2-71	10K	1.2K	1.5K	9.1K	9.1K	1.5K	NO	470	YES	NO	NO	NO	YES	YES
KRF-X9070D	EUROPE E9															
KRF-X9070D	PX Y1	2-91	8.2K	2.2K	2.2K	9.1K	9.1K	1.2K	NO	470	YES	NO	YES	NO	YES	YES
VR-7080	U.S.A. K8 CANADA P8	0-10	8.2K	1.2K	1.5K	9.1K	9.1K	1.2K	NO	470	YES	NO	YES	YES	YES	YES
VR-7070	U.S.A. K7 CANADA P7	0-10	8.2K	1.2K	1.5K	9.1K	9.1K	1.2K	NO	470	YES	NO	YES	YES	YES	YES
VR-7060	U.S.A. K6 CANADA P6	0-11	10K	1.2K	1.5K	10K	10K	1.2K	YES	1.5K	NO	YES	YES	YES	YES	NO

(X09-6760-10) (A/5)

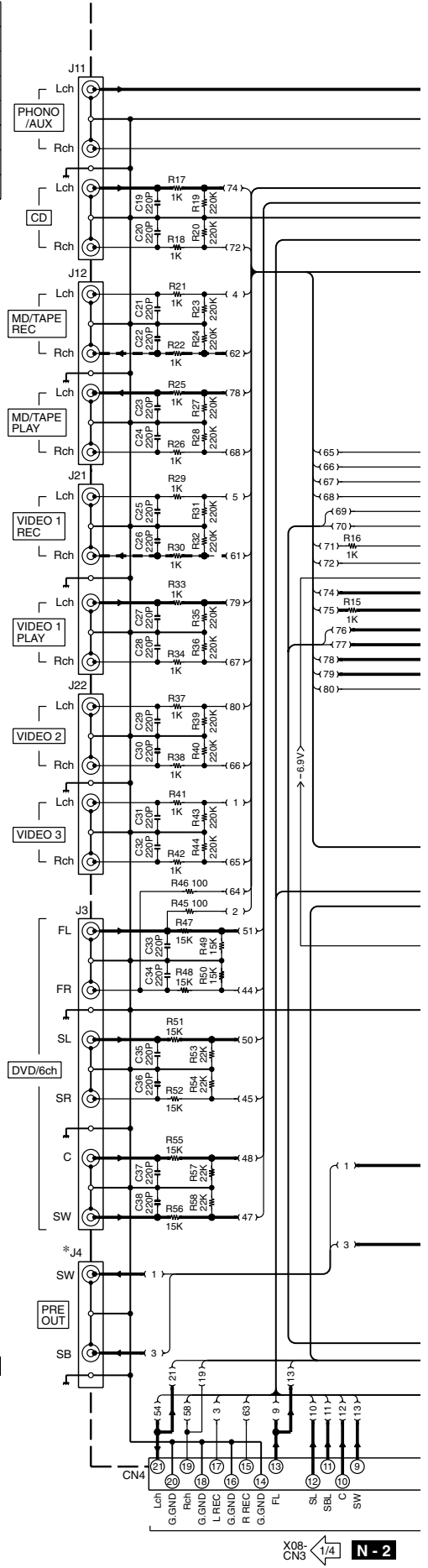

(X09-6760-10) (D/5)

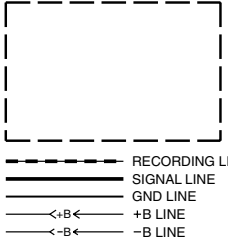

(X09-6760-10) (B/5)

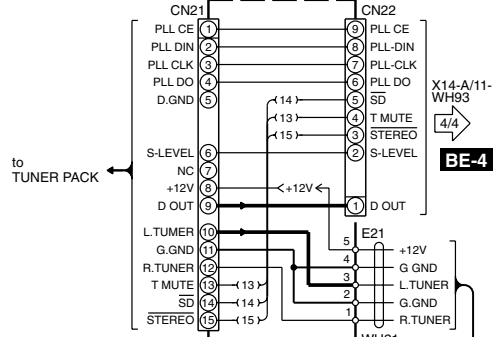

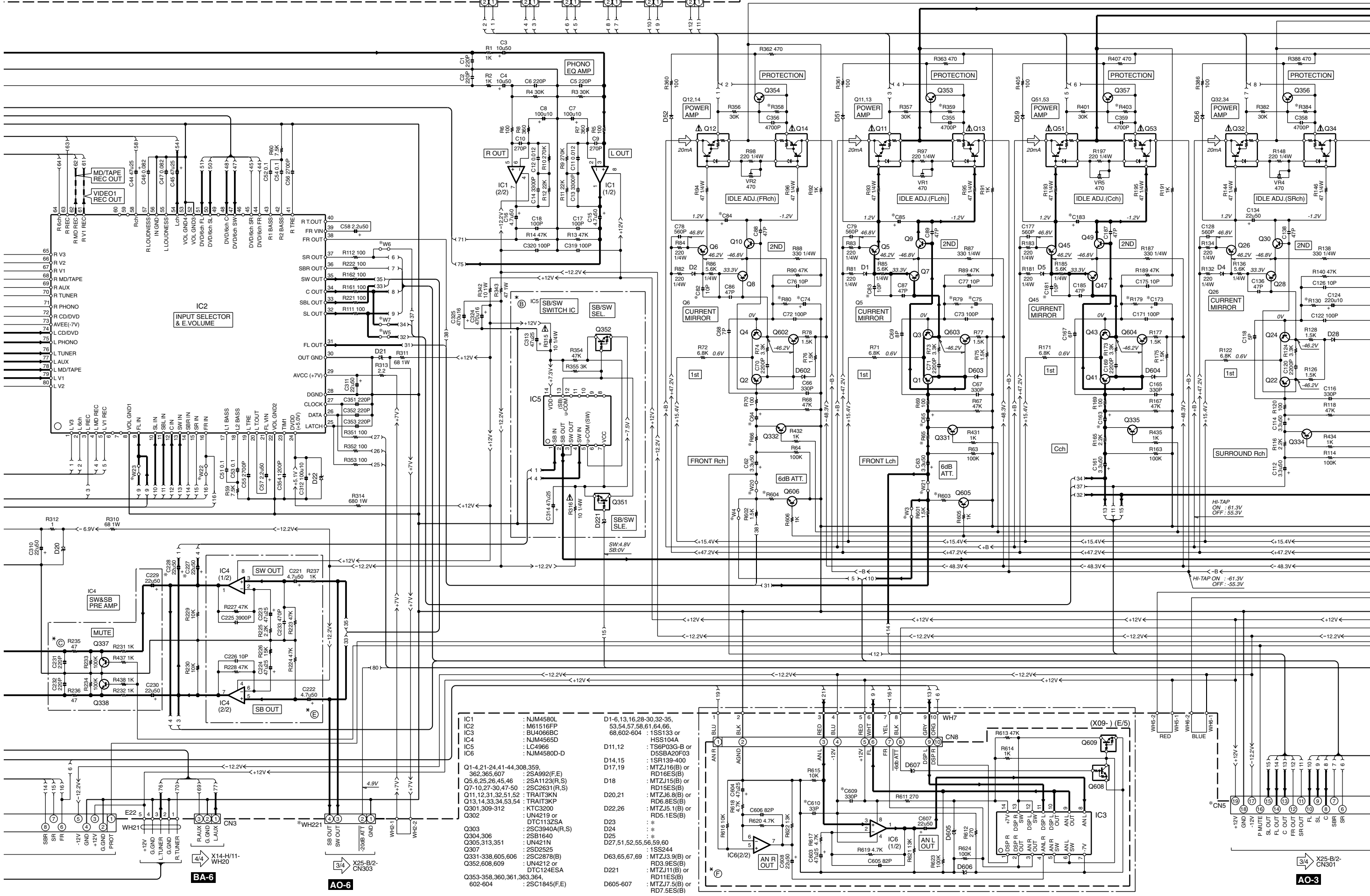

- | | | |
|------|--------------------------|---------------------------|
| IC1 | : NJM4580L | D1-6,13,16,28-30,32-35, |
| IC2 | : M61516FP | 53,54,57,58,61,64,66, |
| IC3 | : BU4066BC | 68,602-604 |
| IC4 | : NJM4565D | : 1SS133 or |
| IC5 | : LC4966 | HSS104A |
| IC6 | : NJM4580D-D | D11,12 |
| | | : TS6P03G-B or |
| Q1 | : 4.21-24,41,44,308,359, | D5SRBA20F03 |
| Q2 | 362,365,607 | D14,15 |
| Q3 | : 2SA1123(R,S) | D17,19 |
| Q4 | : Q7-10,27-30,47-50 | D18 |
| Q5 | : 6.25,26,45,46 | : MTZJ16(B) or |
| Q6 | : Q7-10,27-30,47-50 | RD16ES(B) |
| Q7 | : 10,27-30,47-50 | D20,21 |
| Q8 | : TRAIT3KN | : MTZJ6(B) or |
| Q9 | : 11,12,31,32,51,52 | RD6.8ES(B) |
| Q10 | : 13,14,33,34,53,54 | D22,26 |
| Q11 | : TRAIT3KP | : KTC3200 |
| Q12 | : 301,309-312 | : UN4219 or |
| Q13 | : Q302 | DTC113ZSA |
| Q14 | : Q302 | Q303 |
| Q15 | : Q302 | Q304,306 |
| Q16 | : Q302 | Q305,313,351 |
| Q17 | : Q302 | Q307 |
| Q18 | : Q302 | Q331-338,605,606 |
| Q19 | : Q302 | Q352,608,609 |
| Q20 | : Q302 | Q353-358,360,361,363,364, |
| Q21 | : Q302 | 602-604 |
| Q22 | : Q302 | : 2SC1845(F,E) |
| Q23 | : Q302 | D1-6,13,16,28-30,32-35, |
| Q24 | : Q302 | 53,54,57,58,61,64,66, |
| Q25 | : Q302 | 68,602-604 |
| Q26 | : Q302 | : 1SS133 or |
| Q27 | : Q302 | HSS104A |
| Q28 | : Q302 | D11,12 |
| Q29 | : Q302 | : TS6P03G-B or |
| Q30 | : Q302 | D5SRBA20F03 |
| Q31 | : Q302 | D14,15 |
| Q32 | : Q302 | D17,19 |
| Q33 | : Q302 | D18 |
| Q34 | : Q302 | : MTZJ16(B) or |
| Q35 | : Q302 | RD16ES(B) |
| Q36 | : Q302 | D20,21 |
| Q37 | : Q302 | : MTZJ6(B) or |
| Q38 | : Q302 | RD6.8ES(B) |
| Q39 | : Q302 | D22,26 |
| Q40 | : Q302 | : KTC3200 |
| Q41 | : Q302 | : UN4219 or |
| Q42 | : Q302 | DTC113ZSA |
| Q43 | : Q302 | Q303 |
| Q44 | : Q302 | Q304,306 |
| Q45 | : Q302 | Q305,313,351 |
| Q46 | : Q302 | Q307 |
| Q47 | : Q302 | Q331-338,605,606 |
| Q48 | : Q302 | Q352,608,609 |
| Q49 | : Q302 | Q353-358,360,361,363,364, |
| Q50 | : Q302 | 602-604 |
| Q51 | : Q302 | : 2SC1845(F,E) |
| Q52 | : Q302 | D1-6,13,16,28-30,32-35, |
| Q53 | : Q302 | 53,54,57,58,61,64,66, |
| Q54 | : Q302 | 68,602-604 |
| Q55 | : Q302 | : 1SS133 or |
| Q56 | : Q302 | HSS104A |
| Q57 | : Q302 | D11,12 |
| Q58 | : Q302 | : TS6P03G-B or |
| Q59 | : Q302 | D5SRBA20F03 |
| Q60 | : Q302 | D14,15 |
| Q61 | : Q302 | D17,19 |
| Q62 | : Q302 | D18 |
| Q63 | : Q302 | : MTZJ16(B) or |
| Q64 | : Q302 | RD16ES(B) |
| Q65 | : Q302 | D20,21 |
| Q66 | : Q302 | : MTZJ6(B) or |
| Q67 | : Q302 | RD6.8ES(B) |
| Q68 | : Q302 | D22,26 |
| Q69 | : Q302 | : KTC3200 |
| Q70 | : Q302 | : UN4219 or |
| Q71 | : Q302 | DTC113ZSA |
| Q72 | : Q302 | Q303 |
| Q73 | : Q302 | Q304,306 |
| Q74 | : Q302 | Q305,313,351 |
| Q75 | : Q302 | Q307 |
| Q76 | : Q302 | Q331-338,605,606 |
| Q77 | : Q302 | Q352,608,609 |
| Q78 | : Q302 | Q353-358,360,361,363,364, |
| Q79 | : Q302 | 602-604 |
| Q80 | : Q302 | : 2SC1845(F,E) |
| Q81 | : Q302 | D1-6,13,16,28-30,32-35, |
| Q82 | : Q302 | 53,54,57,58,61,64,66, |
| Q83 | : Q302 | 68,602-604 |
| Q84 | : Q302 | : 1SS133 or |
| Q85 | : Q302 | HSS104A |
| Q86 | : Q302 | D11,12 |
| Q87 | : Q302 | : TS6P03G-B or |
| Q88 | : Q302 | D5SRBA20F03 |
| Q89 | : Q302 | D14,15 |
| Q90 | : Q302 | D17,19 |
| Q91 | : Q302 | D18 |
| Q92 | : Q302 | : MTZJ16(B) or |
| Q93 | : Q302 | RD16ES(B) |
| Q94 | : Q302 | D20,21 |
| Q95 | : Q302 | : MTZJ6(B) or |
| Q96 | : Q302 | RD6.8ES(B) |
| Q97 | : Q302 | D22,26 |
| Q98 | : Q302 | : KTC3200 |
| Q99 | : Q302 | : UN4219 or |
| Q100 | : Q302 | DTC113ZSA |

BA-6

AO-6

AO-3

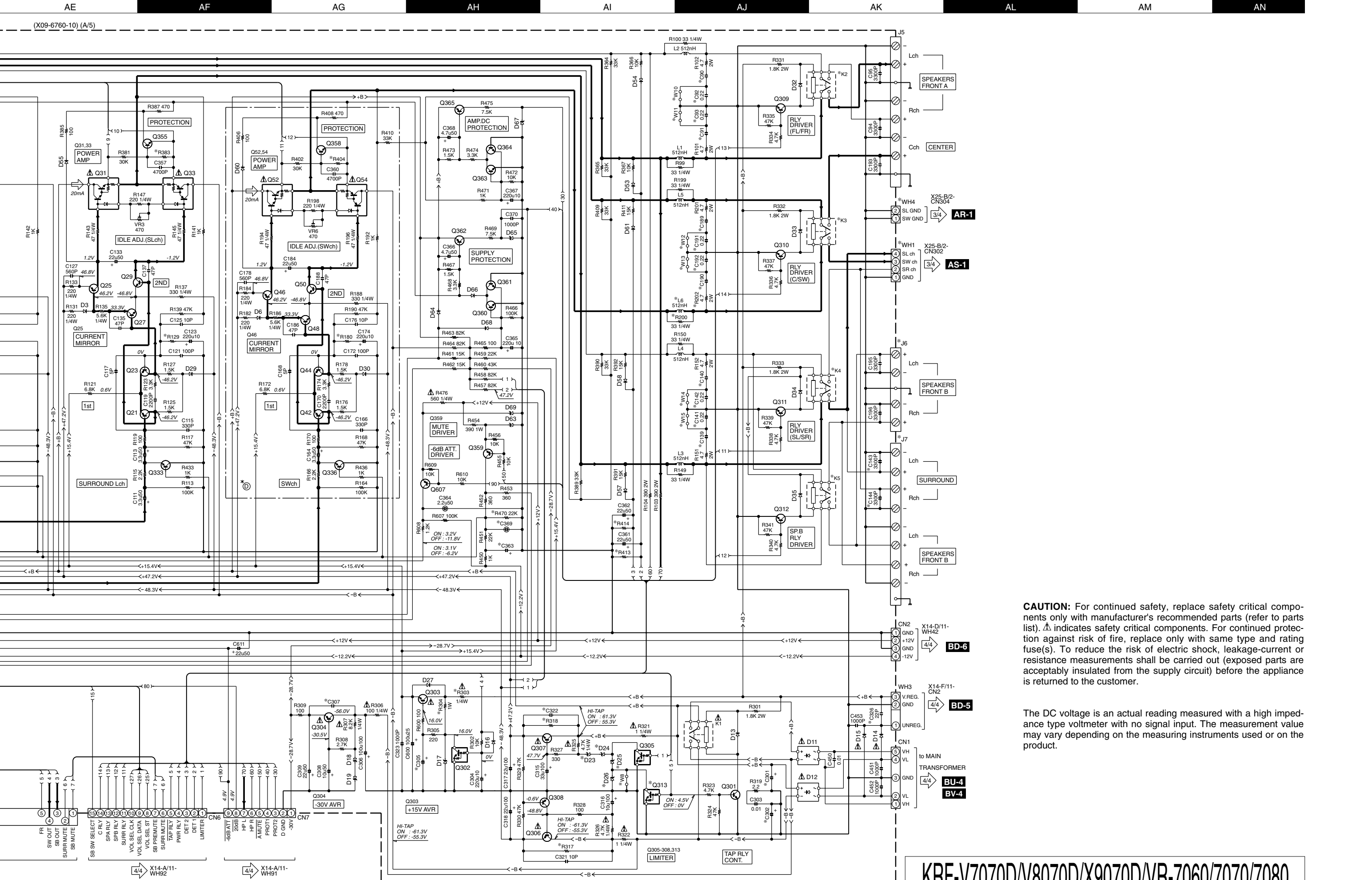

CAUTION: For continued safety, replace safety critical components only with manufacturer's recommended parts (refer to parts list). Δ indicates safety critical components. For continued protection against risk of fire, replace only with same type and rating fuse(s). To reduce the risk of electric shock, leakage-current or resistance measurements shall be carried out (exposed parts are acceptably insulated from the supply circuit) before the appliance is returned to the customer.

The DC voltage is an actual reading measured with a high impedance type voltmeter with no signal input. The measurement value may vary depending on the measuring instruments used or on the product.

VR-7060/7070/7080/KRF-V7070D/V7070D-S (2/4)
KRF-V8070D/V8070D-S/X9070D/X9070D-S (2/4)

Y05-4700-10

KRF-V7070D/V8070D/X9070D/VR-7060/7070/7080

KENWOOD

BF-5

BF-6

BD-6

BD-5

BU-4
BV-4

AR-1

AS-1

- IC101 : NJM2284D
- IC102 : BA766FS
- IC201 : BA05T
- IC202 : TC74HC00AP
- IC401,403 : NJM4580D-D
- IC402,404 : NJM4565D-D
- Q101 : UN4212 or DTC124ESA
- Q203 : KTC3199(Y,GR) or 2SC2785(F,E) or 2SC1740S(Q,R)
- Q204 : KTA1267(Y,GR) or 2SA1175(F,E) or 2SA933AS(Q,R)
- Q301-320,403-408,411,412 : 2SC2878(B)
- Q401,402,409 : DTA124ESA or UN4112
- D203-206 : 1SS133 or HSS104A
- D401 : MTZJ3.9(B) or RD3.9ES(B)
- D402 : MTZJ5.1(B) or RD5.1ES(B)

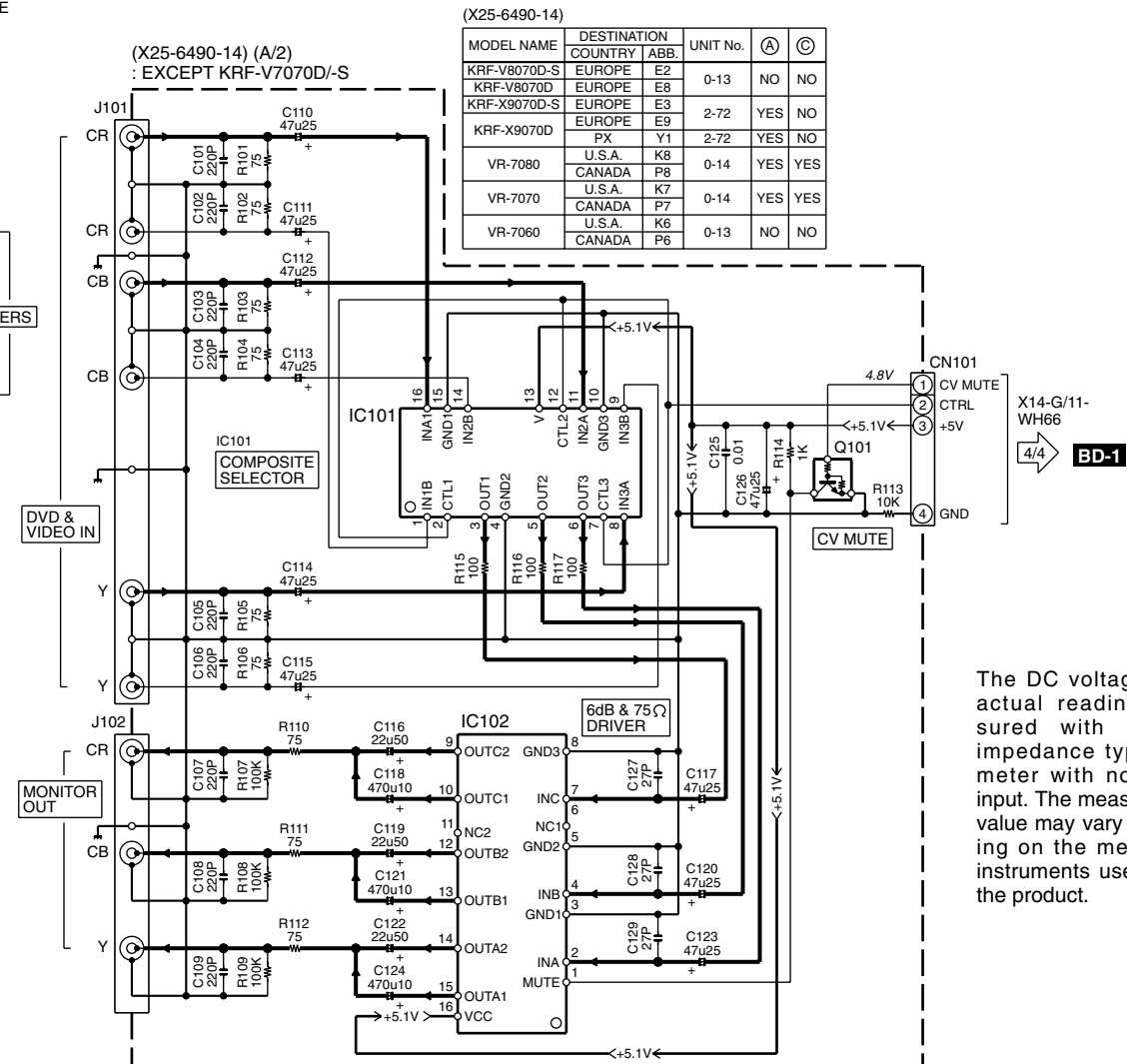
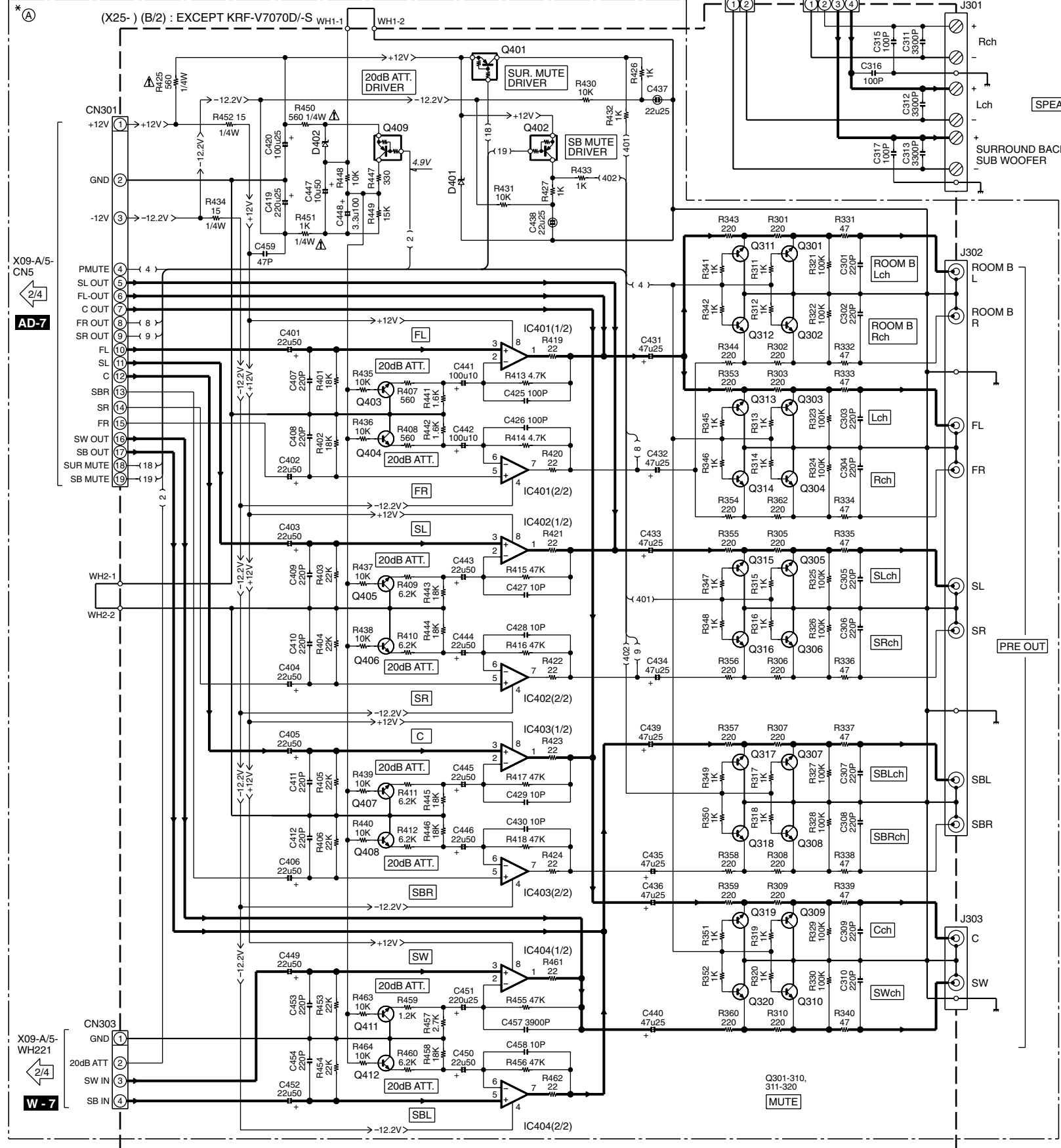

MODEL NAME	DESTINATION COUNTRY	ABB.	UNIT No.	(A)	(C)
KRF-V8070D-S	EUROPE	E2	0-13	NO	NO
KRF-V8070D	EUROPE	E8			
KRF-X9070D-S	EUROPE	E3	2-72	YES	NO
KRF-X9070D	EUROPE	E9			
VR-7080	U.S.A.	K8	0-14	YES	YES
	CANADA	P8			
VR-7070	U.S.A.	K7	0-14	YES	YES
	CANADA	P7			
VR-7060	U.S.A.	K6	0-13	NO	NO
	CANADA	P6			

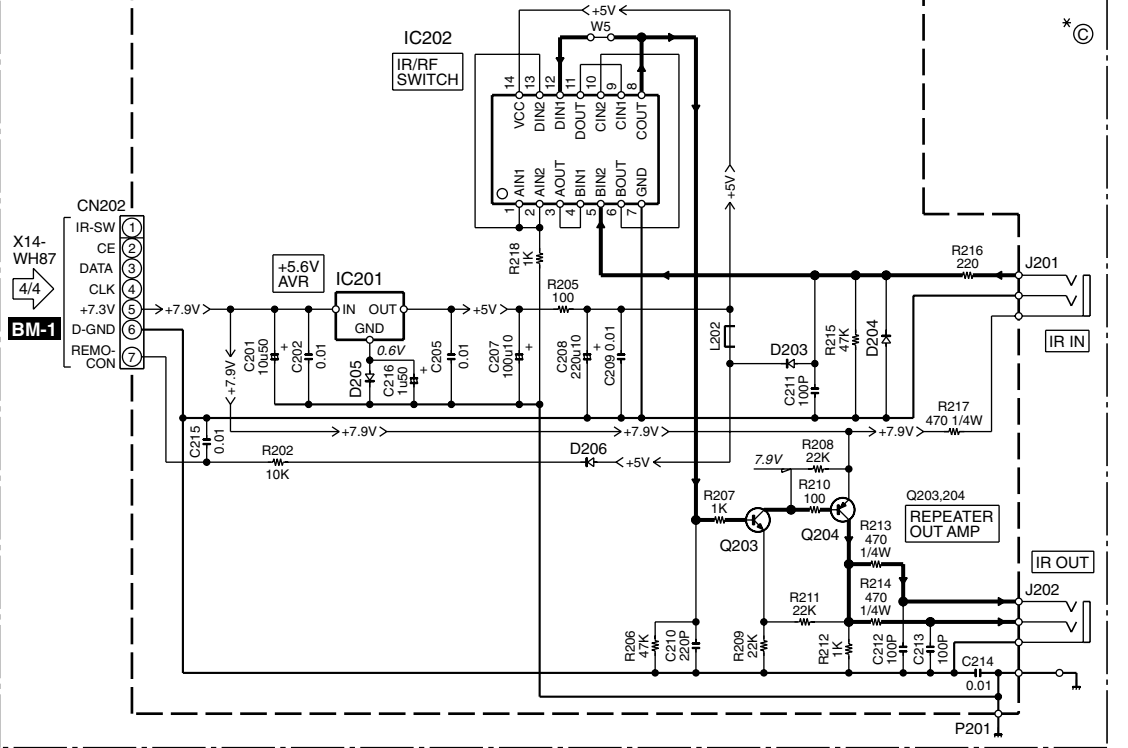

The DC voltage is an actual reading measured with a high impedance type voltmeter with no signal input. The measurement value may vary depending on the measuring instruments used or on the product.

CAUTION: For continued safety, replace safety critical components only with manufacturer's recommended parts (refer to parts list). Δ indicates safety critical components. For continued protection against risk of fire, replace only with same type and rating fuse(s). To reduce the risk of electric shock, leakage-current or resistance measurements shall be carried out (exposed parts are acceptably insulated from the supply circuit) before the appliance is returned to the customer.

Y05-4700-10

KRF-V7070D/V8070D/X9070D/VR-7060/7070/7080

KENWOOD

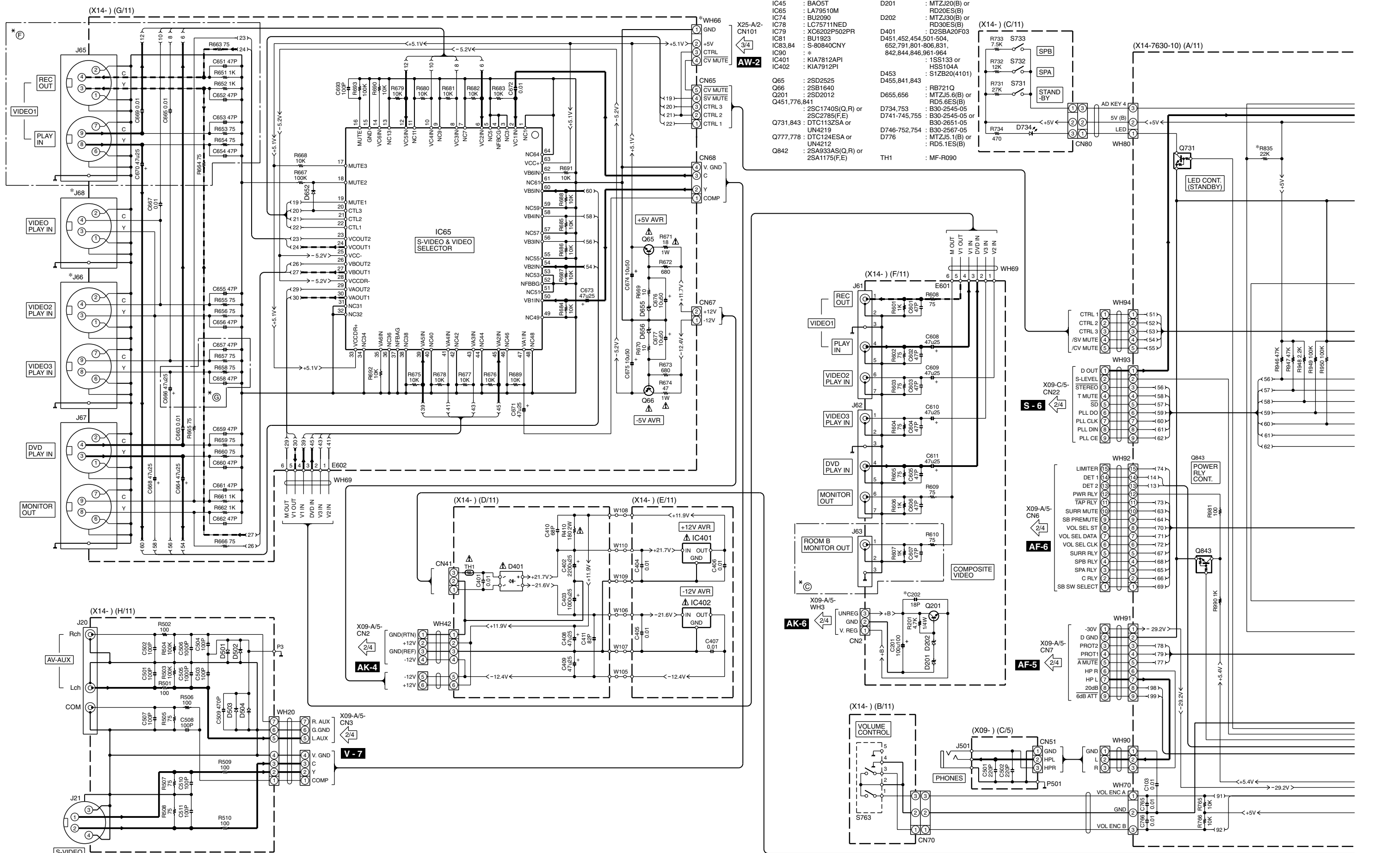

- IC45 : BAO5T
 IC65 : LA79510M
 IC74 : BU2090
 IC78 : LC75711NED
 IC79 : XC6202P502PR
 IC81 : BU1923
 IC83,84 : S-80840CNY
 IC90 : *
 IC401 : KIA7812API
 IC402 : KIA7912PI
- D201 : MTZJ20(B) or RD20ES(B)
 D202 : MTZJ30(B) or RD30ES(B)
 D401 : D2SBA20F03
 D451,452,454,501-504,
 652,791,801-806,831,
 842,844,846,961-964
 D453 : 1SS133 or HSS104A
 D455,841,843 : S1ZB20(4101)
 D459,841,843 : RB721Q
 D734,753 : B30-2545-05 or RD5.6ES(B) or RD5.6ES(B)
 D741-745,755 : B30-2545-05 or B30-2651-05
 D746-752,754 : B30-2567-05
 D776 : MTZJ5.1(B) or RD5.1ES(B)
 TH1 : MF-R090
- Q65 : 2SD2525
 Q66 : 2SB1640
 Q201 : 2SD2012
 Q451,776,841 : 2SC1740S(Q,R) or 2SC2785(F,E)
 Q731,843 : DTC113ZSA or UN4219
 Q777,778 : DTC124ESA or UN4212
 Q842 : 2SA933AS(Q,R) or 2SA1175(F,E)

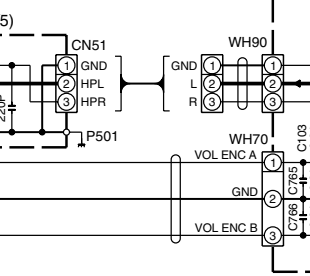
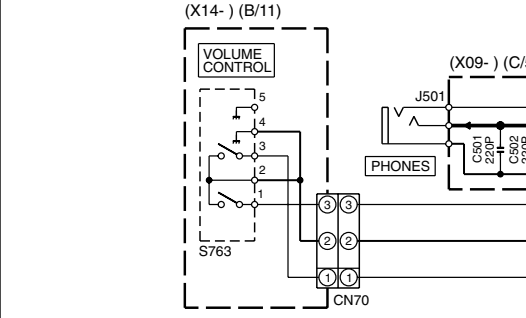
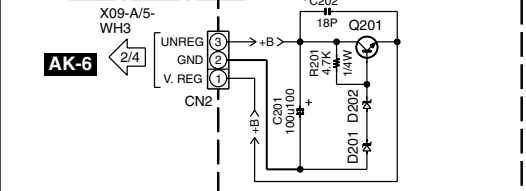
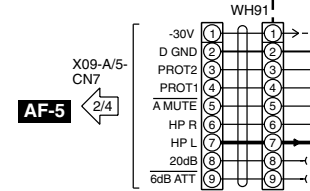
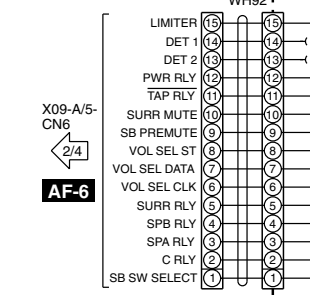
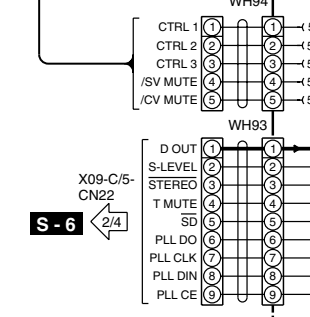
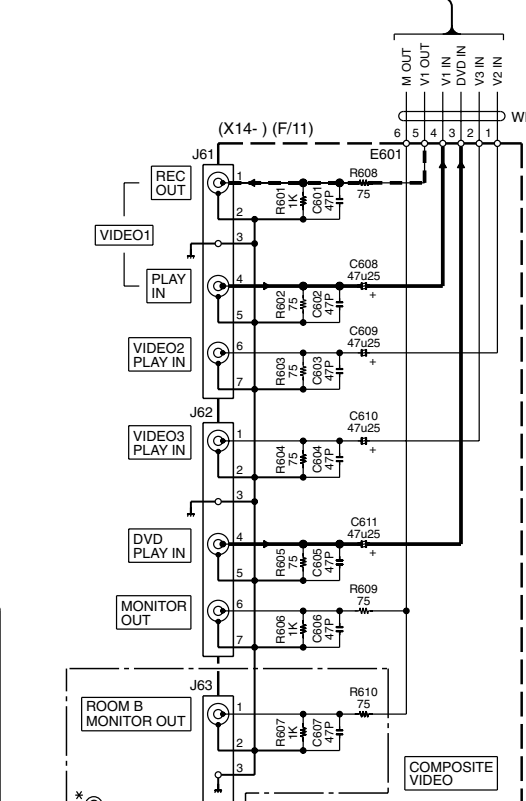
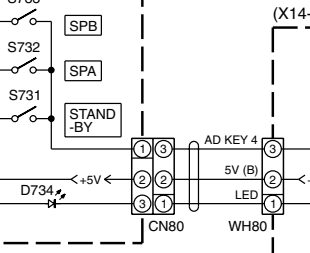

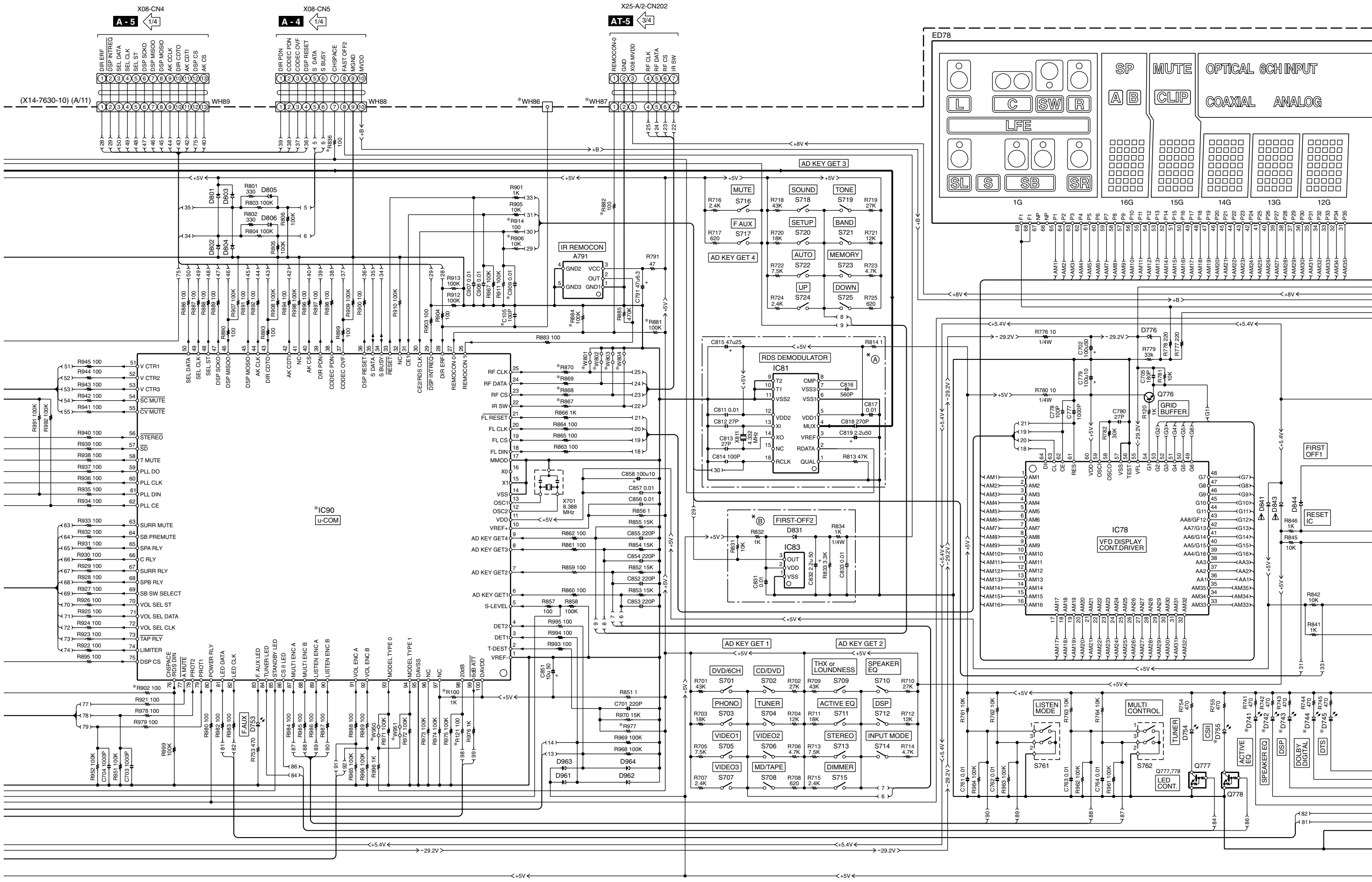

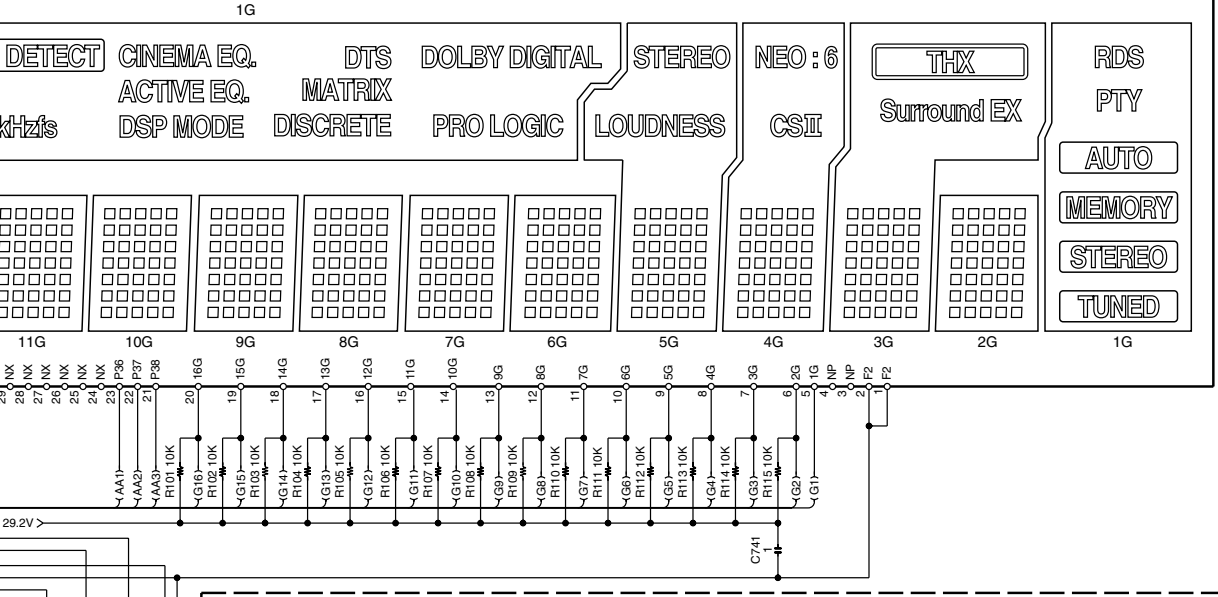

ANODE CONNECTION

	1G	2G	3G	4G	5G	6-14G	15G	16G
P1	Ⓛ	1-1	1-1	1-1	1-1	1-1	1-1	1-1
P2	Ⓒ	2-1	2-1	2-1	2-1	2-1	2-1	2-1
P3	Ⓡ	3-1	3-1	3-1	3-1	3-1	3-1	3-1
P4	Ⓢ	4-1	4-1	4-1	4-1	4-1	4-1	4-1
P5	Ⓢ	5-1	5-1	5-1	5-1	5-1	5-1	5-1
P6	Ⓢ	1-2	1-2	1-2	1-2	1-2	1-2	1-2
P7	Ⓢ	2-2	2-2	2-2	2-2	2-2	2-2	2-2
P8	Ⓢ	3-2	3-2	3-2	3-2	3-2	3-2	3-2
P9	Ⓢ	4-2	4-2	4-2	4-2	4-2	4-2	4-2
P10	Ⓢ (L)	5-2	5-2	5-2	5-2	5-2	5-2	5-2
P11	Ⓢ (C)	1-3	1-3	1-3	1-3	1-3	1-3	1-3
P12	Ⓢ (R)	2-3	2-3	2-3	2-3	2-3	2-3	2-3
P13	Ⓢ (SR)	3-3	3-3	3-3	3-3	3-3	3-3	3-3
P14	Ⓢ (SBR)	4-3	4-3	4-3	4-3	4-3	4-3	4-3
P15	Ⓢ (SBL)	5-3	5-3	5-3	5-3	5-3	5-3	5-3
P16	Ⓢ (SL)	1-4	1-4	1-4	1-4	1-4	1-4	1-4
P17	Ⓢ (SW)	2-4	2-4	2-4	2-4	2-4	2-4	2-4

P18	OPTICAL	3-4	3-4	3-4	3-4	3-4	3-4
P19	COAXIAL	4-4	4-4	4-4	4-4	4-4	4-4
P20	Ⓒ	5-4	5-4	5-4	5-4	5-4	5-4
P21	ANALOG	1-5	1-5	1-5	1-5	1-5	1-5
P22	AUTO DETECT	2-5	2-5	2-5	2-5	2-5	2-5
P23	96kHz	3-5	3-5	3-5	3-5	3-5	3-5
P24	CINEMA EQ.	4-5	4-5	4-5	4-5	4-5	4-5
P25	ACTIVE EQ.	5-5	5-5	5-5	5-5	5-5	5-5
P26	DSP MODE	1-6	1-6	1-6	1-6	1-6	1-6
P27	DTS	2-6	2-6	2-6	2-6	2-6	2-6
P28	MATRIX	3-6	3-6	3-6	3-6	3-6	3-6
P29	DISCRETE	4-6	4-6	4-6	4-6	4-6	4-6
P30	DOLBY DIGITAL	5-6	5-6	5-6	5-6	5-6	5-6
P31	PRO LOGIC	1-7	1-7	1-7	1-7	1-7	1-7
P32		2-7	2-7	2-7	2-7	2-7	2-7
P33	RDS	3-7	3-7	3-7	3-7	3-7	3-7
P34	PTY	4-7	4-7	4-7	4-7	4-7	4-7
P35	AUTO	5-7	5-7	5-7	5-7	5-7	5-7
P36	MEMORY	—	THX	NEO:6	LOUDNESS	—	MUTE SP
P37	STEREO	—	Surround EX	CSII	STEREO	—	CLIP A
P38	TUNED	—	—	—	—	—	B

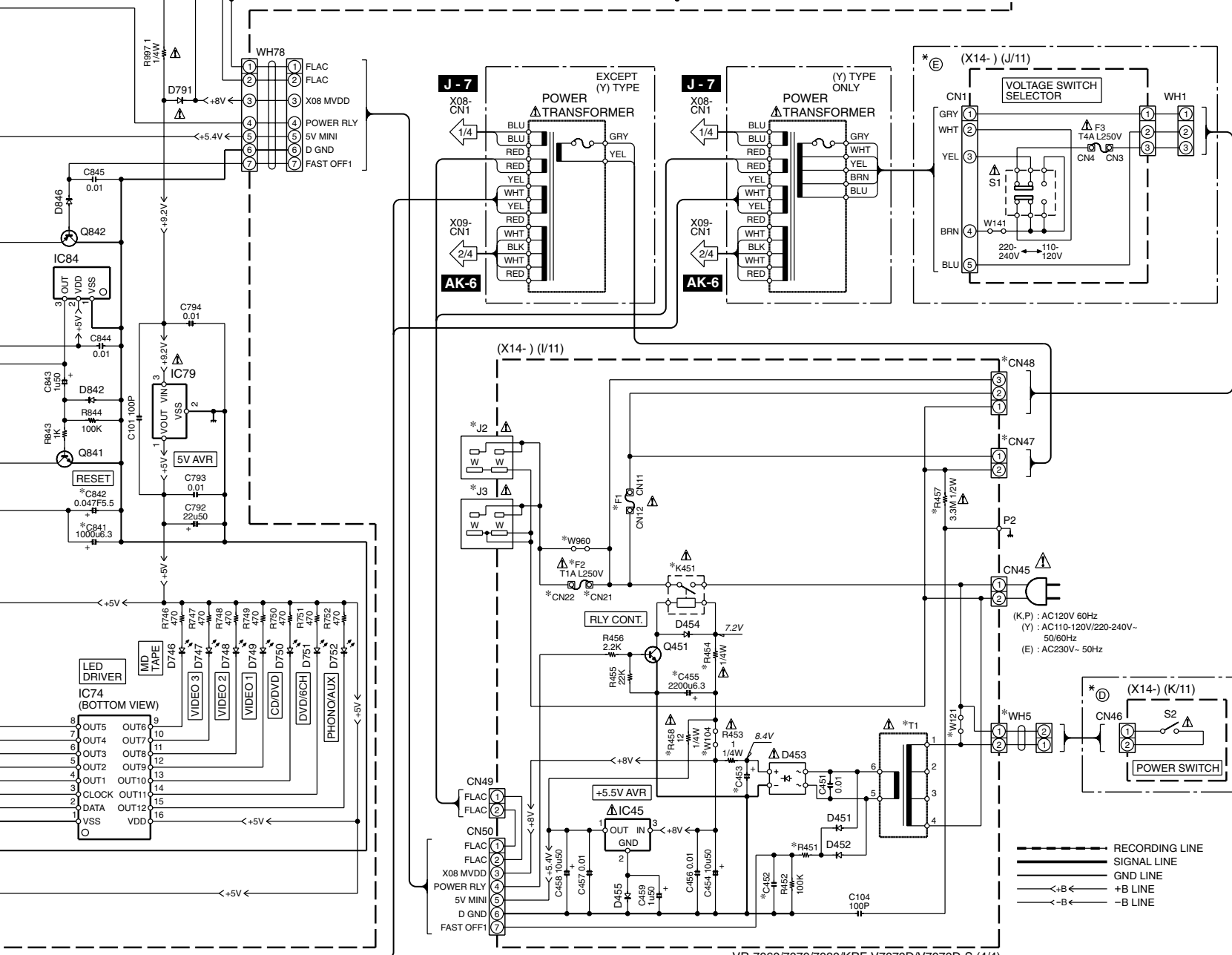
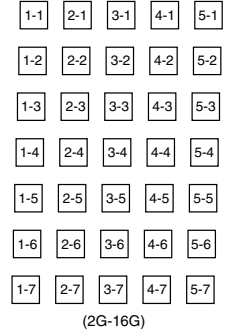

(X14-7630-10)

MODEL NAME	DESTINATION COUNTRY ABB.	UNIT No.	(A)	(B)	(E)	(C)	(D)	(F)	(G)	C105	C202	C452	C453	C455, 909	C841	C842	CN21, 22
KRF-V7070D-S	EUROPE	E1	2-73	YES	NO	NO	NO	YES	NO	YES	0.039	3300u/25	NO	NO	NO	YES	YES
KRF-V7070D	EUROPE	E7	2-73	YES	NO	NO	NO	NO	NO	NO	NO	NO	NO	NO	NO	NO	NO
KRF-V8070D-S	EUROPE	E2	2-72	YES	NO	NO	NO	YES	YES	NO	0.039	3300u/25	NO	NO	NO	YES	YES
KRF-V8070D	EUROPE	E8	2-72	YES	NO	NO	NO	NO	NO	NO	NO	NO	NO	NO	NO	NO	NO
KRF-V8070D	EUROPE	E3	2-71	YES	NO	NO	NO	NO	NO	NO	0.039	3300u/25	NO	NO	NO	NO	NO
KRF-V8070D-S	EUROPE	E9	2-71	YES	NO	NO	NO	YES	YES	NO	0.039	3300u/25	NO	NO	NO	NO	NO
KRF-V8070D	EUROPE	E8	2-72	YES	NO	NO	NO	NO	NO	NO	0.1	3300u/16	NO	NO	NO	NO	NO
KRF-V8070D	EUROPE	E3	2-71	YES	NO	NO	NO	NO	NO	NO	0.1	3300u/16	NO	NO	NO	NO	NO
KRF-V8070D-S	EUROPE	E9	2-71	YES	NO	NO	NO	NO	NO	NO	0.1	3300u/16	NO	NO	NO	NO	NO

(X14-7630-10)

MODEL NAME	DESTINATION COUNTRY ABB.	UNIT No.	CN47	CN48	D741-745	F1	F2	IC90	J2	J3	J66	J68	K451	R100, R121
KRF-V7070D-S	EUROPE	E1	2-73	YES	NO	B30-2651-05	250V T4AL	YES	MN101C49 GGS	NO	YES	NO	YES	S76-0110-05
KRF-V7070D	EUROPE	E7	2-73	YES	NO	B30-2651-05	250V T4AL	YES	MN101C49 GGS	NO	YES	NO	YES	S76-0110-05
KRF-V8070D-S	EUROPE	E2	2-72	YES	NO	B30-2651-05	250V T4AL	YES	MN101C49 GGS	NO	YES	NO	YES	S76-0110-05
KRF-V8070D	EUROPE	E8	2-72	YES	NO	B30-2651-05	250V T4AL	YES	MN101C49 GGS	NO	YES	NO	YES	S76-0110-05
KRF-V8070D	EUROPE	E3	2-71	YES	NO	B30-2651-05	250V T4AL	YES	MN101C49 GGS	NO	YES	NO	YES	S76-0110-05
KRF-V8070D-S	EUROPE	E9	2-71	YES	NO	B30-2651-05	250V T4AL	YES	MN101C49 GGS	NO	YES	NO	YES	S76-0110-05
KRF-V8070D	EUROPE	E8	2-72	YES	NO	B30-2651-05	250V T4AL	YES	MN101C49 GGS	NO	YES	NO	YES	S76-0110-05
KRF-V8070D-S	EUROPE	E9	2-71	YES	NO	B30-2651-05	250V T4AL	YES	MN101C49 GGS	NO	YES	NO	YES	S76-0110-05
KRF-V8070D	EUROPE	E3	2-71	YES	NO	B30-2651-05	250V T4AL	YES	MN101C49 GGS	NO	YES	NO	YES	S76-0110-05

(X14-7630-10)

MODEL NAME	DESTINATION COUNTRY ABB.	UNIT No.	R451	R454	R457	R458, 836	R835, 906	R867-870	R881	R882	R884	R902	R914	R977	T1
KRF-V7070D-S	EUROPE	E1	2-73	130K	27	NO	NO	NO	100K	NO	NO	YES	YES	YES	27K L07-2761-05
KRF-V7070D	EUROPE	E7	2-73	130K	27	NO	NO	NO	100K	NO	NO	YES	YES	YES	L07-2761-05
KRF-V8070D-S	EUROPE	E2	2-72	130K	27	NO	NO	NO	100K	NO	NO	YES	YES	YES	L07-2761-05
KRF-V8070D	EUROPE	E8	2-72	130K	27	NO	NO	NO	100K	NO	NO	YES	YES	YES	L07-2761-05
KRF-V8070D	EUROPE	E3	2-71	130K	27	NO	NO	NO	100K	NO	NO	YES	YES	YES	L07-2761-05
KRF-V8070D-S	EUROPE	E9	2-71	130K	27	NO	NO	NO	100K	NO	NO	YES	YES	YES	L07-2761-05
KRF-V8070D	EUROPE	E8	2-72	130K	27	NO	NO	NO	100K	NO	NO	YES	YES	YES	L07-2761-05
KRF-V8070D-S	EUROPE	E9	2-71	130K	27	NO	NO	NO	100K	NO	NO	YES	YES	YES	L07-2761-05
KRF-V8070D	EUROPE	E3	2-71	130K	27	NO	NO	NO	100K	NO	NO	YES	YES	YES	L07-2761-05

(X14-7630-10)

MODEL NAME	DESTINATION COUNTRY ABB.	UNIT No.	W104	W121	W801-803	W804	W950	W951	W960	W95	W966	W986	W987
KRF-V7070D-S	EUROPE	E1	2-73	YES	NO	YES	YES	NO	NO	YES	NO	NO	NO
KRF-V7070D	EUROPE	E7	2-73	YES	NO	YES	YES	NO	NO	YES	NO	NO	NO
KRF-V8070D-S	EUROPE	E2	2-72	YES	NO	YES	YES	NO	YES	NO	YES	YES	NO
KRF-V8070D	EUROPE	E8	2-72	YES	NO	YES	YES	NO	YES	NO	YES	YES	NO
KRF-V8070D	EUROPE	E3	2-71	YES	NO	YES	YES	NO	NO	YES	YES	YES	NO
KRF-V8070D-S	EUROPE	E9	2-71	YES	NO	YES	YES	NO	NO	YES	YES	YES	NO
KRF-V8070D	EUROPE	E8	2-72	YES	NO	YES	YES	NO	NO	YES	YES	YES	NO
KRF-V8070D-S	EUROPE	E9	2-71	YES	NO	YES	YES	NO	NO	YES	YES	YES	NO
KRF-V8070D	EUROPE	E3	2-71	YES	NO	YES	YES	NO	NO	YES	YES	YES	NO
KRF-V8070D	EUROPE	E8	2-72	YES	NO	YES	YES	NO	NO	YES	YES	YES	NO
KRF-V8070D-S	EUROPE	E9	2-71	YES	NO	YES	YES	NO	NO	YES	YES	YES	NO

CAUTION: For continued safety, replace safety critical components only with manufacturer's recommended parts (refer to parts list). ⚠ indicates safety critical components. For continued protection against risk of fire, replace only with same type and rating fuse(s). To reduce the risk of electric shock, leakage-current or resistance measurements shall be carried out (exposed parts are acceptably insulated from the supply circuit) before the appliance is returned to the customer.

The DC voltage is an actual reading measured with a high impedance type voltmeter with no signal input. The measurement value may vary depending on the measuring instruments used or on the product.

VR-7060/7070/7080/KRF-V7070D/V7070D-S (4/4)
KRF-V8070D/V8070D-S/X9070D/X9070D-S (4/4)

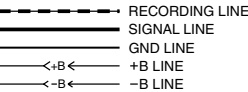

KRF-V7070D/V8070D/X9070D/VR-7060/7070/7080

KRF-V7070D/V8070D/X9070D/VR-7060/7070/7080

EXPLODED VIEW (UNIT)

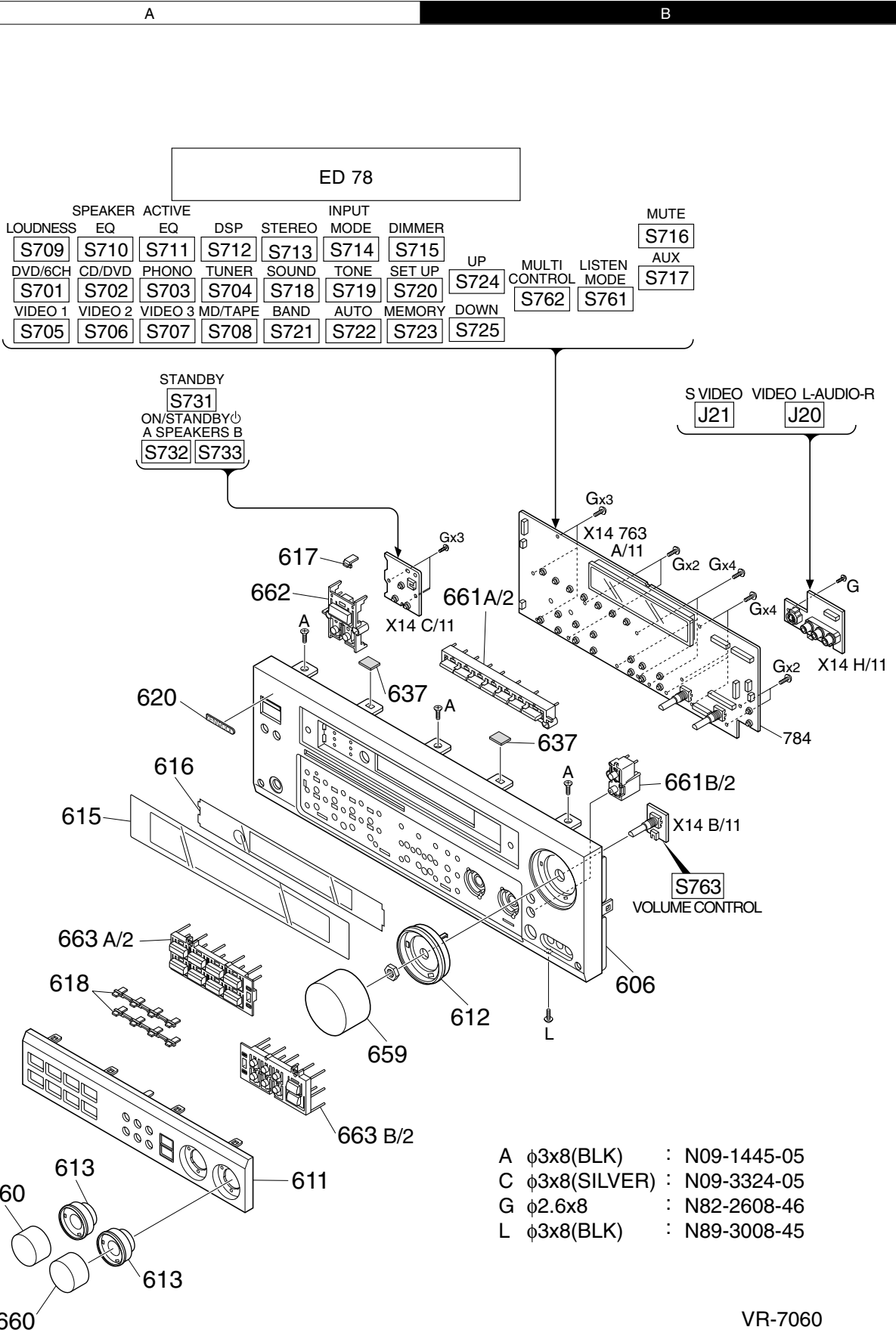

VR-7060

EXPLODED VIEW (UNIT)

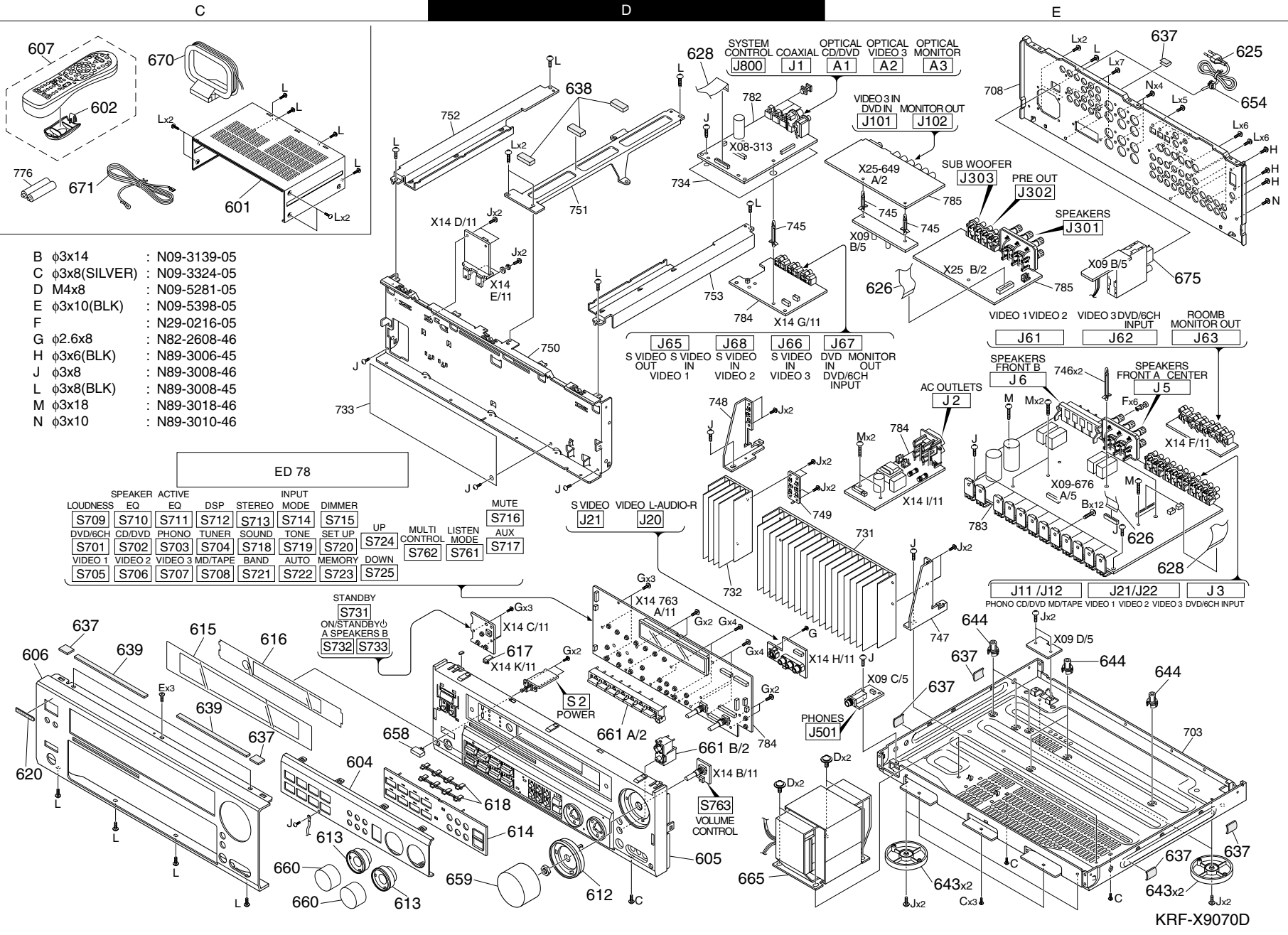

Parts with exploded numbers larger than 700 are not supplied.

KRF-X9070D

* New Parts

Parts without **Parts No.** are not supplied.

Les articles non mentionnés dans le **Parts No.** ne sont pas fournis.

Teile ohne **Parts No.** werden nicht geliefert.

①

Ref. No	Add-ress	New Parts	Parts No.	Description	Desti-nation	Re-marks
MISCELEOVNEOUS						
601	1C		A01-3840-01	METALLIC CABINET	K6P6	
601	1C		A01-3842-01	METALLIC CABINET	E7E8	
601	1C		A01-3842-01	METALLIC CABINET	E9K8P8	
601	1C		A01-3842-01	METALLIC CABINET	K7P7Y1	
601	1C		A01-3843-01	METALLIC CABINET	E1E2E3	
602	1C	*	A09-1274-08	BATTERY COVER	E3	
602	1C	*	A09-1274-08	BATTERY COVER	K7P7E9	
602	1C	*	A09-1274-08	BATTERY COVER	78	
602	1C	*	A09-1275-08	BATTERY COVER	Y1K8P8	
604	2C		A21-3982-12	DRESSING PANEL	E7E8	
604	2C		A21-3982-12	DRESSING PANEL	E9K8P8	
604	2C		A21-3982-12	DRESSING PANEL	K7P7Y1	
604	2C		A21-3983-12	DRESSING PANEL	E1E2E3	
605	2D		A22-1873-01	SUB PANEL ASSY	E7E8	
605	2D		A22-1873-01	SUB PANEL ASSY	E9K8P8	
605	2D		A22-1873-01	SUB PANEL ASSY	K7P7Y1	
605	2D		A22-1874-01	SUB PANEL ASSY	E1E2E3	
606	3B		A60-2169-01	PANEL	K6P6	
606	2C	*	A60-2179-12	PANEL	Y1E9	
606	2C		A60-2180-12	PANEL	E3	
606	2C	*	A60-2181-12	PANEL	E7E8	
606	2C	*	A60-2182-12	PANEL	E1E2	
606	2C	*	A60-2317-02	PANEL	K7P7K8	
606	2C	*	A60-2317-02	PANEL	P8	
607	1C	*	A70-1619-05	REMOTE CONTROLLER ASSY	Y1K8P8	
607	1C	*	A70-1620-05	REMOTE CONTROLLER ASSY	K7P7	
607	1C	*	A70-1621-05	REMOTE CONTROLLER ASSY	E9E3	
607	1C	*	A70-1622-05	REMOTE CONTROLLER ASSY	K6P6	
607	1C	*	A70-1623-05	REMOTE CONTROLLER ASSY	E8E2	
607	1C	*	A70-1623-05	REMOTE CONTROLLER ASSY	7	
-		*	B60-5341-00	INSTRUCTION MANUAL(EN)	Y1K8P8	
-		*	B60-5342-00	INSTRUCTION MANUAL(FR)	P8	
-		*	B60-5343-00	INSTRUCTION MANUAL(EN)	K7P7	
-		*	B60-5344-00	INSTRUCTION MANUAL(FR)	P7	
-		*	B60-5345-00	INSTRUCTION MANUAL(E/S/F/G/I)	E9E3	
-		*	B60-5346-00	INSTRUCTION MANUAL(EN)	K6P6	
-		*	B60-5347-00	INSTRUCTION MANUAL(FR)	P6	
-		*	B60-5348-00	INSTRUCTION MANUAL(E/S/F/G/I)	E8E2	
-		*	B60-5349-00	INSTRUCTION MANUAL(E/S/F/G/I)	7	
611	3A		B07-2596-12	ESCUTCHEON	K6P6	
612	2D		B07-2606-03	ESCUTCHEON	E7E8	
612	2D		B07-2606-03	ESCUTCHEON	E9K8P8	
612	3B		B07-2606-03	ESCUTCHEON	K6P6	
612	2D		B07-2606-03	ESCUTCHEON	K7P7Y1	
612	2D		B07-2607-03	ESCUTCHEON	E1E2E3	
613	2C		B07-2608-03	ESCUTCHEON	E7E8	
613	2C		B07-2608-03	ESCUTCHEON	E9K8P8	
613	3A		B07-2608-03	ESCUTCHEON	K6P6	
613	2C		B07-2608-03	ESCUTCHEON	K7P7Y1	
613	2C		B07-2609-03	ESCUTCHEON	E1E2E3	
614	2D		B07-2619-13	ESCUTCHEON	E7E8	
614	2D		B07-2619-13	ESCUTCHEON	E9K8P8	
614	2D		B07-2619-13	ESCUTCHEON	K7P7Y1	

L : Scandinavia K : USA P : Canada R : Mexico C : China I : Malaysia
 Y : PX(Far East,Hawaii) T : England E : Europe G : Germany V : China(Shanghai)
 Y : AAFES(Europe) X : Australia Q : Russia H : Korea M : Other Areas Δ indicates safety critical components.

* New Parts

Parts without **Parts No.** are not supplied.

Les articles non mentionnés dans le **Parts No.** ne sont pas fournis.

Teile ohne **Parts No.** werden nicht geliefert.

②

Ref. No	Add-ress	New Parts	Parts No.	Description	Desti-nation	Re-marks
614	2D		B07-2620-13	ESCUTCHEON	E1E2E3	
615	2C	*	B10-3925-02	FRONT GLASS	K7P7	
615	2C	*	B10-3926-02	FRONT GLASS	E9E3	
615	2A	*	B10-3927-02	FRONT GLASS	K6P6	
615	2C	*	B10-3928-02	FRONT GLASS	E8E2	
615	2C	*	B10-3930-02	FRONT GLASS	7	
615	2C	*	B10-3933-02	FRONT GLASS	K8P8	
615	2C	*	B10-3938-02	FRONT GLASS	Y1	
616	2C	*	B11-1571-03	COLOR FILTER	9	
616	2A	*	B11-1572-03	COLOR FILTER	78	
617	2D		B12-0440-04	INDICATOR	E8E2	
617	2D		B12-0440-04	INDICATOR	79	
617	2A		B12-0441-04	INDICATOR	K6P6	
618	3A,2D		B12-0442-04	INDICATOR		
620	2A,2C		B43-0314-04	KENWOOD BADGE		
Δ 625	1E		E30-2941-05	AC POWER CORD	K6K7K8	
Δ 625	1E		E30-2941-05	AC POWER CORD	P6P7P8	
Δ 625	1E		E30-2942-05	AC POWER CORD	E8E2	
Δ 625	1E		E30-2942-05	AC POWER CORD	E9E3	
Δ 625	1E		E30-2942-05	AC POWER CORD	7	
Δ 625	1E	*	E30-7289-05	AC POWER CORD	Y1	
626	1E,2E		E35-2841-05	FLAT CABLE	9	
628	1D,2E		E35-3216-05	FLAT CABLE		
637	2A,2E		G11-2885-04	CUSHION		
638	1D		G11-2886-04	CUSHION		
639	2C		G11-2887-04	CUSHION	E8E2	
639	2C		G11-2887-04	CUSHION	79	
-		*	H10-7888-02	POLYSTYRENE FOAMED FIXTURE		
-		*	H10-7890-02	POLYSTYRENE FOAMED FIXTURE		
-			H25-0232-04	PROTECTION BAG (235X350X0.03)		
-			H25-0391-04	PROTECTION BAG		
-			H30-0623-04	ADHESIVE DOUBLE-COATED TAPE	9	
-		*	H50-4721-04	ITEM CARTON CASE	K7P7	
-		*	H50-4722-04	ITEM CARTON CASE	E9	
-		*	H50-4723-04	ITEM CARTON CASE	E3	
-		*	H50-4724-04	ITEM CARTON CASE	K6P6	
-		*	H50-4725-04	ITEM CARTON CASE	E8	
-		*	H50-4726-04	ITEM CARTON CASE	E2	
-		*	H50-4728-04	ITEM CARTON CASE	E7	
-		*	H50-4729-04	ITEM CARTON CASE	E1	
-		*	H50-4777-04	ITEM CARTON CASE	K8P8	
-		*	H50-4779-04	ITEM CARTON CASE	Y1	
-			J61-0307-05	WIRE BAND		
643	2E		J02-1532-03	FOOT		
644	2E		J19-3751-04	UNIT HOLDER		
Δ 654	1E		J42-0349-05	POWER CORD BUSHING		
658	2C		K27-2384-04	KNOB (BUTTON)	E7E8	
658	2C		K27-2384-04	KNOB (BUTTON)	Y1E9	
658	2C		K27-2481-04	KNOB (BUTTON)	E1E2E3	
659	3A		K29-8103-04	KNOB	K6P6	
659	2D	*	K29-8267-04	KNOB	K7P7Y1	
659	2D	*	K29-8267-04	KNOB	K8P8	
659	2D	*	K29-8268-04	KNOB	E1E2E3	
659	2D	*	K29-8269-04	KNOB	E7E8E9	

L : Scandinavia K : USA P : Canada R : Mexico C : China I : Malaysia
 Y : PX(Far East,Hawaii) T : England E : Europe G : Germany V : China(Shanghai)
 Y : AAFES(Europe) X : Australia Q : Russia H : Korea M : Other Areas Δ indicates safety critical components.

KRF-V7070D/N8070D/X9070D/NR-7060/7070/7080
PARTS LIST

* New Parts
Parts without **Parts No.** are not supplied.
Les articles non mentionnés dans le **Parts No.** ne sont pas fournis.
Teile ohne **Parts No.** werden nicht geliefert.

③

Ref. No	Add-ress	New Parts	Parts No.	Description	Desti-nation	Re-marks
660	3A		K29-8105-04	KNOB	K6P6	
660	2C	*	K29-8271-04	KNOB	E7E8	
660	2C	*	K29-8271-04	KNOB	E9K8P8	
660	2C	*	K29-8271-04	KNOB	K7P7Y1	
660	2C	*	K29-8272-04	KNOB	E1E2E3	
661	2D		K29-8136-03	KNOB ASSY	E7	
661	2D		K29-8136-03	KNOB ASSY	E9K8P8	
661	2B		K29-8136-03	KNOB ASSY	K6P6E8	
661	2D		K29-8136-03	KNOB ASSY	K7P7Y1	
661	2D		K29-8137-03	KNOB ASSY	E1E2E3	
662	2A		K29-8107-02	KNOB	K6P6	
663	3A		K29-8111-02	KNOB	K6P6	
△ 665	2D		L07-3138-05	POWER TRANSFORMER	K6P6	
△ 665	2D	*	L07-3240-15	POWER TRANSFORMER	K7P7K8	
△ 665	2D	*	L07-3240-15	POWER TRANSFORMER	P8	
△ 665	2D	*	L07-3241-15	POWER TRANSFORMER	Y1	
△ 665	2D	*	L07-3251-05	POWER TRANSFORMER	E9E3	
△ 665	2D	*	L07-3252-05	POWER TRANSFORMER	E8E2	
△ 665	2D	*	L07-3252-05	POWER TRANSFORMER	7	
670	1C		T90-0893-05	LOOP ANTENNA		
671	1C		T90-0877-05	LEAD WIRE ANTENNA		
675	1E	*	W02-2974-05	TUNER ASSY	K6P6	
675	1E	*	W02-2974-05	TUNER ASSY	K7P7K8	
675	1E	*	W02-2974-05	TUNER ASSY	P8	
675	1E	*	W02-2975-05	TUNER ASSY	Y1	
675	1E	*	W02-2976-05	TUNER ASSY	E8E2	
675	1E	*	W02-2976-05	TUNER ASSY	E9E3	
675	1E	*	W02-2976-05	TUNER ASSY	7	
SURROUND (X08-3130-10)						
C1 ,2			CK73GB1H472K	CHIP C	4700PF	K
C3 ,4			CC73GCH1H220J	CHIP C	22PF	J
C5			CE04KW1E470M	ELECTRO	47UF	25WV
C6			CE04KW1E470M	ELECTRO	47UF	25WV
C7			CE04KW1H100M	ELECTRO	10UF	50WV
C8 ,9			CC73GCH1H270J	CHIP C	27PF	J
C10			CK73GB1H102K	CHIP C	1000PF	K
C11			CK73FB1E104K	CHIP C	0.10UF	K
C12			CK73GB1H102K	CHIP C	1000PF	K
C15			CC73GCH1H330J	CHIP C	33PF	J
C16			CK73GB1H102K	CHIP C	1000PF	K
C17			CC73GCH1H330J	CHIP C	33PF	J
C18			CC73GCH1H220J	CHIP C	22PF	J
C19			CC73GCH1H330J	CHIP C	33PF	J
C20			CK73GB1H103K	CHIP C	0.010UF	K
C30			CK73FB1E104K	CHIP C	0.10UF	K
C31			CE04RW1C4R7M	ELECTRO	4.7UF	16WV
C32			CK73FB1E104K	CHIP C	0.10UF	K
C33			CE04KW1H100M	ELECTRO	10UF	50WV
C34			CE04KW1H220M	ELECTRO	22UF	50WV
C35			CK73FB1E104K	CHIP C	0.10UF	K
C36 ,37			CC73GCH1H180J	CHIP C	18PF	J
C38			CC73GCH1H330J	CHIP C	33PF	J
C39			CK73GB1H103K	CHIP C	0.010UF	K

L : Scandinavia K : USA P : Canada R : Mexico C : China I : Malaysia
Y : PX(Far East,Hawaii) T : England E : Europe G : Germany V : China(Shanghai)
Y : AAFES(Europe) X : Australia Q : Russia H : Korea M : Other Areas △ indicates safety critical components .

* New Parts
Parts without **Parts No.** are not supplied.
Les articles non mentionnés dans le **Parts No.** ne sont pas fournis.
Teile ohne **Parts No.** werden nicht geliefert.

④

Ref. No	Add-ress	New Parts	Parts No.	Description	Desti-nation	Re-marks
C101,102			CE04KW1H100M	ELECTRO	10UF	50WV
C103-106			CK73GB1H182K	CHIP C	1800PF	K
C107			CC73GCH1H101J	CHIP C	100PF	J
C108			CK73GB1H472K	CHIP C	4700PF	K
C121			CC73GCH1H102J	CHIP C	1000PF	J
C122			CC73GCH1H101J	CHIP C	100PF	J
C123,124			CC73GCH1H220J	CHIP C	22PF	J
C125			CK73GB1H103K	CHIP C	0.010UF	K
C126			CC73GCH1H101J	CHIP C	100PF	J
C127,128			CE04KW1H4R7M	ELECTRO	4.7UF	50WV
C153,154			C91-1597-05	CERAMIC	4.7UF	Z
C201,202			CE04KW1H100M	ELECTRO	10UF	50WV
C203,204			CK73GB1H222K	CHIP C	2200PF	K
C205,206			CK73GB1H821K	CHIP C	820PF	K
C207			CC73GCH1H101J	CHIP C	100PF	J
C208			CK73GB1H472K	CHIP C	4700PF	K
C209,210			CE04KW1H4R7M	ELECTRO	4.7UF	50WV
C301,302			CE04KW1H100M	ELECTRO	10UF	50WV
C303-306			CK73GB1H182K	CHIP C	1800PF	K
C307			CC73GCH1H101J	CHIP C	100PF	J
C308			CK73GB1H472K	CHIP C	4700PF	K
C309,310			CE04KW1H4R7M	ELECTRO	4.7UF	50WV
C401,402			CE04KW1H100M	ELECTRO	10UF	50WV
C403			CK73GB1H182K	CHIP C	1800PF	K
C404			CK73GB1H822K	CHIP C	8200PF	K
C405			CK73GB1H182K	CHIP C	1800PF	K
C406			CK73GB1H822K	CHIP C	8200PF	K
C407			CC73GCH1H101J	CHIP C	100PF	J
C408			CK73GB1H103K	CHIP C	0.010UF	K
C409,410			CE04KW1H4R7M	ELECTRO	4.7UF	50WV
C500-513			CK73FB1E104K	CHIP C	0.10UF	K
C514			CC73GCH1H470J	CHIP C	47PF	J
C515			CE04KW1A471M	ELECTRO	470UF	10WV
C600-603			CK73FB1E104K	CHIP C	0.10UF	K
C800,801			CC73GCH1H221J	CHIP C	220PF	J
C802			CK73GB1H103K	CHIP C	0.010UF	K
C803			CK73FB1H103K	CHIP C	0.010UF	K
C900			CE04KW1C472M	ELECTRO	4700UF	16WV
C901			CK73FB1E104K	CHIP C	0.10UF	K
C908			CK73FF1C225Z	CHIP C	2.2UF	Z
C909			CK73FB1E104K	CHIP C	0.10UF	K
C910			CE04KW1A101M	ELECTRO	100UF	10WV
C911			CK73FB1E104K	CHIP C	0.10UF	K
C912			CC73GCH1H390J	CHIP C	39PF	J
C913			CK73FB1E104K	CHIP C	0.10UF	K
C914			CK73FB1H103K	CHIP C	0.010UF	K
C920			CE04KW1A101M	ELECTRO	100UF	10WV
C921			CK73FB1E104K	CHIP C	0.10UF	K
C922			CC73GCH1H470J	CHIP C	47PF	J
C923			CK73FB1E104K	CHIP C	0.10UF	K
C930			CE04KW1A101M	ELECTRO	100UF	10WV
C931			CK73FB1E104K	CHIP C	0.10UF	K
C932			CC73GCH1H100D	CHIP C	10PF	D
C933			CK73FB1E104K	CHIP C	0.10UF	K

L : Scandinavia K : USA P : Canada R : Mexico C : China I : Malaysia
Y : PX(Far East,Hawaii) T : England E : Europe G : Germany V : China(Shanghai)
Y : AAFES(Europe) X : Australia Q : Russia H : Korea M : Other Areas △ indicates safety critical components .

* New Parts

Parts without **Parts No.** are not supplied.

Les articles non mentionnés dans le **Parts No.** ne sont pas fournis.

Teile ohne **Parts No.** werden nicht geliefert.

5

Ref. No	Address	New Parts	Parts No.	Description	Desti-nation	Re-marks
CN3			E40-8484-05	FLAT CABLE CONNECTOR		
J1			E63-1080-05	PIN JACK		
J800			E11-0293-05	MINIATURE PHONE JACK(2P)		
L1 ,2			L92-0510-05	CHIP FERRITE		
X1			L77-2296-05	CRYSTAL RESONATOR(12.288MHZ)		
CP51,52			R90-0714-05	MULTI-COMP 10K X4		
CP600-604			R90-0728-05	MULTI-COMP 180 X4		
R1			RK73GB1J471J	CHIP R 470 J 1/16W		
R2			RK73GB1J471J	CHIP R 470 J 1/16W	89	
R3			R92-1946-05	METAL GLAZE 4.7 J 1/4W	89	
R4			RK73GB1J471J	CHIP R 470 J 1/16W	9	
R5			R92-1946-05	METAL GLAZE 4.7 J 1/4W	9	
R6			R92-1946-05	METAL GLAZE 4.7 J 1/4W		
R7			RK73GB1J820J	CHIP R 82 J 1/16W		
R8			RK73GB1J821J	CHIP R 820 J 1/16W		
R9			RK73GB1J105J	CHIP R 1.0M J 1/16W		
R10			RK73GB1J221J	CHIP R 220 J 1/16W		
R11			RK73GB1J183J	CHIP R 18K J 1/16W		
R14 ,15			RK73GB1J330J	CHIP R 33 J 1/16W		
R16 -19			RK73GB1J220J	CHIP R 22 J 1/16W		
R20			RK73GB1J221J	CHIP R 220 J 1/16W		
R21			RK73GB1J220J	CHIP R 22 J 1/16W		
R22			RK73GB1J105J	CHIP R 1.0M J 1/16W		
R23			RK73GB1J330J	CHIP R 33 J 1/16W		
R30			RK73GB1J220J	CHIP R 22 J 1/16W		
R31			R92-1946-05	METAL GLAZE 4.7 J 1/4W		
R32			RK73GB1J221J	CHIP R 220 J 1/16W		
R101,102			RK73GB1J222J	CHIP R 2.2K J 1/16W		
R103,104			RK73GB1J104J	CHIP R 100K J 1/16W		
R105,106			RK73GB1J102J	CHIP R 1.0K J 1/16W		
R107,108			RK73GB1J103J	CHIP R 10K J 1/16W		
R109,110			RK73GB1J472J	CHIP R 4.7K J 1/16W		
R111,112			RK73GB1J221J	CHIP R 220 J 1/16W		
R121,122			RK73GB1J112J	CHIP R 1.1K J 1/16W		
R123,124			RK73GB1J242J	CHIP R 2.4K J 1/16W		
R125-128			RK73GB1J103J	CHIP R 10K J 1/16W		
R129,130			RK73GB1J101J	CHIP R 100 J 1/16W		
R151,152			RK73GB1J562J	CHIP R 5.6K J 1/16W		
R153,154			RK73GB1J432J	CHIP R 4.3K J 1/16W		
R155-158			RK73GB1J472J	CHIP R 4.7K J 1/16W		
R201,202			RK73GB1J332J	CHIP R 3.3K J 1/16W		
R203,204			RK73GB1J104J	CHIP R 100K J 1/16W		
R205,206			RK73GB1J911J	CHIP R 910 J 1/16W		
R207,208			RK73GB1J272J	CHIP R 2.7K J 1/16W		
R209,210			RK73GB1J562J	CHIP R 5.6K J 1/16W		
R211,212			RK73GB1J221J	CHIP R 220 J 1/16W		
R213			RK73GB1J472J	CHIP R 4.7K J 1/16W		
R214,215			RK73GB1J562J	CHIP R 5.6K J 1/16W		
R216			RK73GB1J472J	CHIP R 4.7K J 1/16W		
R301,302			RK73GB1J222J	CHIP R 2.2K J 1/16W		
R303,304			RK73GB1J104J	CHIP R 100K J 1/16W		
R305,306			RK73GB1J102J	CHIP R 1.0K J 1/16W		
R307,308			RK73GB1J103J	CHIP R 10K J 1/16W		
R309,310			RK73GB1J472J	CHIP R 4.7K J 1/16W		

L : Scandinavia K : USA P : Canada R : Mexico C : China I : Malaysia
 Y : PX(Far East,Hawaii) T : England E : Europe G : Germany V : China(Shanghai)
 Y : AAFES(Europe) X : Australia Q : Russia H : Korea M : Other Areas Δ indicates safety critical components .

* New Parts

Parts without **Parts No.** are not supplied.

Les articles non mentionnés dans le **Parts No.** ne sont pas fournis.

Teile ohne **Parts No.** werden nicht geliefert.

5

Ref. No	Address	New Parts	Parts No.	Description	Desti-nation	Re-marks
R311 ,312			RK73GB1J221J	CHIP R 220 J 1/16W		
R401			RK73GB1J222J	CHIP R 2.2K J 1/16W		
R402,403			RK73GB1J104J	CHIP R 100K J 1/16W		
R404			RK73GB1J273J	CHIP R 27K J 1/16W		
R405			RK73GB1J102J	CHIP R 1.0K J 1/16W		
R406			RK73GB1J183J	CHIP R 18K J 1/16W		
R407,408			RK73GB1J103J	CHIP R 10K J 1/16W		
R409			RK73GB1J472J	CHIP R 4.7K J 1/16W		
R410			RK73GB1J562J	CHIP R 5.6K J 1/16W		
R411,412			RK73GB1J221J	CHIP R 220 J 1/16W		
R501-508			RK73GB1J104J	CHIP R 100K J 1/16W		
R509-511			RK73GB1J221J	CHIP R 220 J 1/16W		
R512			RK73GB1J104J	CHIP R 100K J 1/16W		
R513			RK73GB1J102J	CHIP R 1.0K J 1/16W		
R514			RK73GB1J472J	CHIP R 4.7K J 1/16W		
R515			R92-4583-05	METAL GLAZE 10 J 1/2W		
R541			RK73GB1J220J	CHIP R 22 J 1/16W		
R542,543			RK73GB1J101J	CHIP R 100 J 1/16W		
R601-608			RK73GB1J104J	CHIP R 100K J 1/16W		
R900			R92-1918-05	CHIP R 0.33 J 1/4W		
R910			R92-1946-05	METAL GLAZE 4.7 J 1/4W		
R920			RS14KB3D180J	FL-PROOF RS 18 J 2W		
R930			RS14KB3D4R7J	FL-PROOF RS 4.7 J 2W		
R931			RS14KB3D5R6J	FL-PROOF RS 5.6 J 2W		
R950			RK73GB1J152J	CHIP R 1.5K J 1/16W		
R951			RK73GB1J102J	CHIP R 1.0K J 1/16W		
R952			RK73GB1J472J	CHIP R 4.7K J 1/16W		
R953			RK73GB1J473J	CHIP R 47K J 1/16W		
R954,955			RK73GB1J221J	CHIP R 220 J 1/16W		
W999			R92-0679-05	CHIP R 0 OHM		
S800			S62-0034-05	SLIDE SWITCH	Y1	
D1			DAN202U	DIODE		
D1			MA142WK	DIODE		
D1			1SS301	DIODE		
D3			DAN202U	DIODE		
D3			MA142WK	DIODE		
D3			1SS301	DIODE		
D4			DAP202U	DIODE		
D4			MA142WA	DIODE		
D4			1SS300	DIODE		
D800,801			MA111	DIODE		
D900			D2SBA20F03	DIODE	Y1	
D901 ,902			MA111	DIODE		
D910			HZU3.9(B2)	ZENER DIODE		
D910			UDZ3.9B	ZENER DIODE		
D920			HZU3.9(B2)	ZENER DIODE		
D920			UDZ3.9B	ZENER DIODE		
D930			HZU5.6(B2)	ZENER DIODE		
D930			UDZ5.6B	ZENER DIODE		
D950			HZU5.1(B2)	ZENER DIODE		
D950			UDZ5.1B	ZENER DIODE		
D951			MA111	DIODE		
IC2			AK4112BVF	MOS-IC		
IC3			TC7WH241FU	MOS-IC		

L : Scandinavia K : USA P : Canada R : Mexico C : China I : Malaysia
 Y : PX(Far East,Hawaii) T : England E : Europe G : Germany V : China(Shanghai)
 Y : AAFES(Europe) X : Australia Q : Russia H : Korea M : Other Areas Δ indicates safety critical components .

KRF-V7070D/N8070D/X9070D/NR-7060/7070/7080
PARTS LIST

* New Parts
Parts without **Parts No.** are not supplied.
Les articles non mentionnés dans le **Parts No.** ne sont pas fournis.
Teile ohne **Parts No.** werden nicht geliefert.

7

Ref. No	Add-ress	New Parts	Parts No.	Description	Desti-nation	Re-marks
IC4			AK4529-VQ	MOS-IC		
IC5			TC7SHU04FU	MOS-IC		
IC6			TC7WU04FU	MOS-IC		
IC7			TC74VHC175FT	MOS-IC		
IC11			NJM4565M	ANALOGUE IC		
IC11			NJM4565MD	IC(OP AMP X2)		
IC12			NJU7311AM	MOS-IC		
IC21			NJM4565M	ANALOGUE IC		
IC21			NJM4565MD	IC(OP AMP X2)		
IC31			NJM4565M	ANALOGUE IC		
IC31			NJM4565MD	IC(OP AMP X2)		
IC41			NJM4565M	ANALOGUE IC		
IC41			NJM4565MD	IC(OP AMP X2)		
IC50			ADSST-MEL322	MOS-IC		
IC51			27W40180N6A05	ROM IC	9	
IC51		*	27W40180N6705	ROM IC	7	
IC51		*	27W40180N6905	ROM IC	8	
IC52			A61L6316-12V	SRAM IC		
IC52			UT61L6416MC10	SRAM IC		
IC52		*	UT61L6416MC12	SRAM IC	78	
IC60			TC74HCT7007AF	MOS-IC		
IC61			TC74VHC125FT	MOS-IC		
IC90			BA05T	ANALOGUE IC		
IC91			NJU7223F25	ANALOGUE IC		
IC92			BA033T	ANALOGUE IC		
IC93			BA05T	ANALOGUE IC		
IC123			NJM4565M	ANALOGUE IC		
IC123			NJM4565MD	IC(OP AMP X2)		
Q950			2SA1576A(R,S)	TRANSISTOR		
Q950			2SB1218A(Q,R)	TRANSISTOR		
Q951			2SC4081(R,S)	TRANSISTOR		
Q951			2SD1819A(Q,R)	TRANSISTOR		
A1			W02-2731-05	OPTIC RECEIVING MODULE		
A2			W02-2731-05	OPTIC RECEIVING MODULE	89	
A3			W02-2732-05	OSCILLATING MODULE	9	
AUDIO (X09-6760-10)						
C1 ,2			CC45FSL1H221J	CERAMIC	220PF	J
C3 ,4			CE04LW1H100M	ELECTRO	10UF	50WV
C5 ,6			CC45FSL1H221J	CERAMIC	220PF	J
C7 ,8			CE04LW1A101M	ELECTRO	100UF	10WV
C9 ,10			CC45FSL1H271J	CERAMIC	270PF	J
C11 ,12			CQ93FMG1H123J	MYLAR	0.012UF	J
C13 ,14			CK45FB1H332K	CERAMIC	3300PF	K
C15 ,16			CE04LW1H4R7M	ELECTRO	4.7UF	50WV
C17 ,18			CC45FCH1H101J	CERAMIC	100PF	J
C19 -38			CC45FSL1H221J	CERAMIC	220PF	J
C44 ,45			CE04LW1E470M	ELECTRO	47UF	25WV
C46 ,47			CQ93FMG1H823J	MYLAR	0.082UF	J
C51 -54			C91-1573-05	MP-C	0.10UF	J
C55 ,56			CQ93FMG1H272J	MYLAR	2700PF	J
C57 ,58			CE04LW1H2R2M	ELECTRO	2.2UF	50WV
C62 ,63			CE04KW1H3R3M	ELECTRO	3.3UF	50WV
C64 ,65			CE04KW1H3R3M	ELECTRO	3.3UF	50WV
C64 ,65			CE04KW2A3R3M	ELECTRO	3.3UF	100WV

L : Scandinavia K : USA P : Canada R : Mexico C : China I : Malaysia
Y : PX(Far East,Hawaii) T : England E : Europe G : Germany V : China(Shanghai)
Y : AAFES(Europe) X : Australia Q : Russia H : Korea M : Other Areas Δ indicates safety critical components .

* New Parts
Parts without **Parts No.** are not supplied.
Les articles non mentionnés dans le **Parts No.** ne sont pas fournis.
Teile ohne **Parts No.** werden nicht geliefert.

8

Ref. No	Add-ress	New Parts	Parts No.	Description	Desti-nation	Re-marks
C66 ,67			CC45FSL1H331J	CERAMIC	330PF	J
C68			CC45FCH1H070D	CERAMIC	7.0PF	D
C69			CC45FCH1H080D	CERAMIC	8.0PF	D
C70 ,71			CK45FB1H222K	CERAMIC	2200PF	K
C72 ,73			CC45FCH1H101J	CERAMIC	100PF	J
C74 ,75			CE04KW1A221M	ELECTRO	220UF	10WV
C74 ,75			CE04KW1E101M	ELECTRO	100UF	25WV
C76 ,77			CC45FCH1H100D	CERAMIC	10PF	D
C78 ,79			CK45FB1H561K	CERAMIC	560PF	K
C82 ,83			CC45FCH1H100D	CERAMIC	10PF	D
C84 ,85			CE04KW1E470M	ELECTRO	47UF	25WV
C84 ,85			CE04KW1H220M	ELECTRO	22UF	50WV
C86 ,87			CC45FSL1H470J	CERAMIC	47PF	J
C88 ,89			CC45FSL2H470J	CERAMIC	47PF	J
C90 -93			C91-1577-05	MP-C	0.22UF	J
C90 -93			C91-1577-05	MP-C	0.22UF	J
C90 ,91			C91-1573-05	MP-C	0.10UF	J
C90 ,91			C91-1573-05	MP-C	0.10UF	J
C90 ,91			C91-1573-05	MP-C	0.10UF	J
C90 ,91			C91-1573-05	MP-C	0.10UF	J
C94 ,95			CK45FB1H332K	CERAMIC	3300PF	K
C111 ,112			CE04KW1H3R3M	ELECTRO	3.3UF	50WV
C113 ,114			CE04LW1H3R3M	ELECTRO	3.3UF	50WV
C115 ,116			CC45FSL1H331J	CERAMIC	330PF	J
C117 ,118			CC45FCH1H050C	CERAMIC	5.0PF	C
C119 ,120			CK45FB1H222K	CERAMIC	2200PF	K
C121 ,122			CC45FCH1H101J	CERAMIC	100PF	J
C123 ,124			CE04KW1A221M	ELECTRO	220UF	10WV
C125 ,126			CC45FCH1H100D	CERAMIC	10PF	D
C127 ,128			CK45FB1H561K	CERAMIC	560PF	K
C133 ,134			CE04LW1H220M	ELECTRO	22UF	50WV
C135 ,136			CC45FSL1H470J	CERAMIC	47PF	J
C137 ,138			CC45FSL2H470J	CERAMIC	47PF	J
C139-142			C91-1577-05	MP-C	0.22UF	J
C139-142			C91-1577-05	MP-C	0.22UF	J
C139-142			C91-1577-05	MP-C	0.22UF	J
C139 ,140			C91-1573-05	MP-C	0.10UF	J
C139 ,140			C91-1573-05	MP-C	0.10UF	J
C139 ,140			C91-1573-05	MP-C	0.10UF	J
C139 ,140			C91-1573-05	MP-C	0.10UF	J
C143 ,144			CK45FB1H332K	CERAMIC	3300PF	K
C161			CE04KW1H3R3M	ELECTRO	3.3UF	50WV
C163			CE04KW1H3R3M	ELECTRO	3.3UF	50WV
C163			CE04KW2A3R3M	ELECTRO	3.3UF	100WV
C164			CE04LW1H3R3M	ELECTRO	3.3UF	50WV
C165			CC45FSL1H331J	CERAMIC	330PF	J
C166			CC45FSL1H331J	CERAMIC	330PF	J
C167			CC45FCH1H060D	CERAMIC	6.0PF	D
C168			CC45FCH1H050C	CERAMIC	5.0PF	C
C169			CK45FB1H222K	CERAMIC	2200PF	K
C170			CK45FB1H222K	CERAMIC	2200PF	K
C171			CC45FCH1H101J	CERAMIC	100PF	J
C172			CC45FCH1H101J	CERAMIC	100PF	J
C173			CE04KW1A221M	ELECTRO	220UF	10WV
C173			CE04KW1E101M	ELECTRO	100UF	25WV
C174			CE04KW1A221M	ELECTRO	220UF	10WV

L : Scandinavia K : USA P : Canada R : Mexico C : China I : Malaysia
Y : PX(Far East,Hawaii) T : England E : Europe G : Germany V : China(Shanghai)
Y : AAFES(Europe) X : Australia Q : Russia H : Korea M : Other Areas Δ indicates safety critical components .

* New Parts

Parts without **Parts No.** are not supplied.
Les articles non mentionnés dans le **Parts No.** ne sont pas fournis.
Teile ohne **Parts No.** werden nicht geliefert.

9

Ref. No	Add-ress	New Parts	Parts No.	Description	Desti-nation	Re-marks
C175			CC45FCH1H100D	CERAMIC 10PF	D	
C176			CC45FCH1H100D	CERAMIC 10PF	D	89
C177			CK45FB1H561K	CERAMIC 560PF	K	
C178			CK45FB1H561K	CERAMIC 560PF	K	89
C181			CC45FCH1H100D	CERAMIC 10PF	D	78
C183			CE04KW1E470M	ELECTRO 47UF	25WV	9
C183			CE04KW1H220M	ELECTRO 22UF	50WV	78
C184			CE04LW1H220M	ELECTRO 22UF	50WV	89
C185			CC45FSL1H470J	CERAMIC 47PF	J	
C186			CC45FSL1H470J	CERAMIC 47PF	J	89
C187			CC45FSL2H470J	CERAMIC 47PF	J	
C188			CC45FSL2H470J	CERAMIC 47PF	J	89
C189			C91-1577-05	MP-C 0.22UF	J	7
C189-192			C91-1577-05	MP-C 0.22UF	J	E8E2
C189-192			C91-1577-05	MP-C 0.22UF	J	Y1E9E3
C189,190			C91-1573-05	MP-C 0.10UF	J	K6P6
C189,190			C91-1573-05	MP-C 0.10UF	J	K7P7K8
C189,190			C91-1573-05	MP-C 0.10UF	J	P8
C191			C91-1577-05	MP-C 0.22UF	J	7
C193			CK45FB1H332K	CERAMIC 3300PF	K	
C195,196			CK45FB1H332K	CERAMIC 3300PF	K	
C221,222			CE04LW1H4R7M	ELECTRO 4.7UF	50WV	78
C223,224			CE04LW1E470M	ELECTRO 47UF	25WV	78
C225			CQ93FMG1H392J	MYLAR 3900PF	J	78
C226			CC45FCH1H100D	CERAMIC 10PF	D	78
C227,228			CE04LW1H220M	ELECTRO 22UF	50WV	89
C229,230			CE04LW1H220M	ELECTRO 22UF	50WV	78
C231,232			CC25FSL1H221J	CERAMIC 220PF	J	78
C233			CK45FB1H471K	CERAMIC 470PF	K	78
C301,302			C90-5749-05	ELECTRO 10000UF	75WV	K7P7Y1
C301,302		*	C90-5771-05	ELECTRO 10000UF	75WV	K8P8
C301,302		*	C90-5772-05	ELECTRO 4700UF	75WV	E9E3
C301,302		*	C90-5772-05	ELECTRO 4700UF	75WV	E8E2
C301,302		*	C90-5775-05	ELECTRO 4700UF	75WV	7
C303			CQ93FMG1H103J	MYLAR 0.010UF	J	
C304			CE04LW1A221M	ELECTRO 220UF	10WV	
C305			CE04KW1H101M	ELECTRO 100UF	50WV	K6P6
C305			CE04KW1H101M	ELECTRO 100UF	50WV	K7P7Y1
C305			CE04KW1H101M	ELECTRO 100UF	50WV	K8P8
C305			CE04KW1J101M	ELECTRO 100UF	63WV	E8E2
C305			CE04KW1J101M	ELECTRO 100UF	63WV	E9E3
C305			CE04KW1J101M	ELECTRO 100UF	63WV	7
C306			CE04LW2A101M	ELECTRO 100UF	100WV	
C307			CC45FSL1H181J	CERAMIC 180PF	J	9
C307			CC45FSL1H221J	CERAMIC 220PF	J	78
C308			CE04LW1H100M	ELECTRO 10UF	50WV	
C309			CE04LW1H220M	ELECTRO 22UF	50WV	
C310,311			CE04LW1H220M	ELECTRO 22UF	50WV	
C312			CE04LW1A101M	ELECTRO 100UF	10WV	
C313,314			CE04LW1E470M	ELECTRO 47UF	25WV	89
C315			CE04DW2A330M	ELECTRO 33UF	100WV	9
C315			CE04LW2A330M	ELECTRO 33UF	100WV	78
C316			CE04LW2A100M	ELECTRO 10UF	100WV	
C317,318			CE04KW2A220M	ELECTRO 22UF	100WV	

L : Scandinavia K : USA P : Canada R : Mexico C : China I : Malaysia
 Y : PX(Far East,Hawaii) T : England E : Europe G : Germany V : China(Shanghai)
 Y : AAFES(Europe) X : Australia Q : Russia H : Korea M : Other Areas Δ indicates safety critical components.

* New Parts

Parts without **Parts No.** are not supplied.
Les articles non mentionnés dans le **Parts No.** ne sont pas fournis.
Teile ohne **Parts No.** werden nicht geliefert.

10

Ref. No	Add-ress	New Parts	Parts No.	Description	Desti-nation	Re-marks
C319,320			CC45FCH1H101J	CERAMIC 100PF	J	
C321			CC45FCH1H100D	CERAMIC 10PF	D	
C322			CC45FCH1H120J	CERAMIC 12PF	J	9
C322			CC45FCH1H150J	CERAMIC 15PF	J	78
C323			CK45FB1H102K	CERAMIC 1000PF	K	
C324,325			CE04DW1C471M	ELECTRO 470UF	16WV	
C326			CC45FCH1H220J	CERAMIC 22PF	J	9
C351-353			CC45FSL1H221J	CERAMIC 220PF	J	
C354			CQ93FMG1H122J	MYLAR 1200PF	J	
C355-359			CK45FF1H472Z	CERAMIC 4700PF	Z	
C360			CK45FF1H472Z	CERAMIC 4700PF	Z	89
C361			CE04KW1H220M	ELECTRO 22UF	50WV	
C362			CE04LW1H220M	ELECTRO 22UF	50WV	
C363			CE04KW1E470M	ELECTRO 47UF	25WV	9
C363			CE04LW1H220M	ELECTRO 22UF	50WV	78
C364			CE04HW1H2R2M	NP-ELEC 2.2UF	50WV	
C365			CE04KW1A221M	ELECTRO 220UF	10WV	
C366			CE04LW1H4R7M	ELECTRO 4.7UF	50WV	
C367			CE04KW1A221M	ELECTRO 220UF	10WV	
C368			CE04LW1H4R7M	ELECTRO 4.7UF	50WV	
C369			CE04HW1C330M	NP-ELEC 33UF	16WV	78
C369			CE04HW1E220M	NP-ELEC 22UF	25WV	9
C370			CK45FB1H102K	CERAMIC 1000PF	K	
C450			CK45FE2H103P	CERAMIC 0.010UF	P	
C451-453			CK45FB2H102K	CERAMIC 1000PF	K	
C501,502			CC45FSL1H221J	CERAMIC 220PF	J	
C600			CE04KW1E101M	ELECTRO 100UF	25WV	9
C603,604			CE04KW1E470M	ELECTRO 47UF	25WV	9
C605,606			CC45FCH1H820J	CERAMIC 82PF	J	9
C607,608			CE04LW1H220M	ELECTRO 22UF	50WV	
C609			CC45FSL1H331J	CERAMIC 330PF	J	E9E3
C610			CC45FSL1H330J	CERAMIC 33PF	J	E9E3
C611			CE04KW1H220M	ELECTRO 22UF	50WV	
CN4			E40-8484-05	FLAT CABLE CONNECTOR		
CN5			E40-8483-05	FLAT CABLE CONNECTOR		9
J3			E63-1247-05	PIN JACK		
J4			E63-1248-05	PIN JACK		78
J5			E70-0150-05	SCREW TERMINAL BOARD		
J6			E70-0160-05	LOCK TERMINAL BOARD		89
J7			E70-0161-05	LOCK TERMINAL BOARD		7
J11 ,12		*	E63-1317-05	PIN JACK		
J21 ,22		*	E63-1317-05	PIN JACK		
J501			E11-0190-05	PHONE JACK (3P)		
J501			E11-0271-05	PHONE JACK (METAL SLEEVE)		
L1 -5			L39-0085-05	PHASE COMPENSATION COIL		
L6			L39-0085-05	PHASE COMPENSATION COIL		89
R81 -84			RD14NB2E221J	RD 220	J	1/4W
R85 ,86			RD14NB2E562J	RD 5.6K	J	1/4W
R87 ,88			RD14NB2E331J	RD 330	J	1/4W
R93 -96			RD14NB2E470J	RD 47	J	1/4W
R97 ,98			RD14NB2E221J	RD 220	J	1/4W
R99 ,100			RD14NB2E330J	RD 33	J	1/4W
R101,102			RS14KB3D4R7J	FL-PROOF RS 4.7	J	2W

L : Scandinavia K : USA P : Canada R : Mexico C : China I : Malaysia
 Y : PX(Far East,Hawaii) T : England E : Europe G : Germany V : China(Shanghai)
 Y : AAFES(Europe) X : Australia Q : Russia H : Korea M : Other Areas Δ indicates safety critical components.

KRF-V7070D/N8070D/X9070D/NR-7060/7070/7080
PARTS LIST

* New Parts
Parts without **Parts No.** are not supplied.
Les articles non mentionnés dans le **Parts No.** ne sont pas fournis.
Teile ohne **Parts No.** werden nicht geliefert.

11

Ref. No	Add-ress	New Parts	Parts No.	Description	Desti-nation	Re-marks
R103,104			RS14KB3D391J	FL-PROOF RS 390 J 2W		
R131-134			RD14NB2E221J	RD 220 J 1/4W		
R135,136			RD14NB2E562J	RD 5.6K J 1/4W		
R137,138			RD14NB2E331J	RD 330 J 1/4W		
R143-146			RD14NB2E470J	RD 47 J 1/4W		
R147,148			RD14NB2E221J	RD 220 J 1/4W		
R149,150			RD14NB2E330J	RD 33 J 1/4W		
R151,152			RS14KB3D4R7J	FL-PROOF RS 4.7 J 2W		
R181			RD14NB2E221J	RD 220 J 1/4W		
R182			RD14NB2E221J	RD 220 J 1/4W	89	
R183			RD14NB2E221J	RD 220 J 1/4W		
R184			RD14NB2E221J	RD 220 J 1/4W	89	
R185			RD14NB2E562J	RD 5.6K J 1/4W		
R186			RD14NB2E562J	RD 5.6K J 1/4W	89	
R187			RD14NB2E331J	RD 330 J 1/4W		
R188			RD14NB2E331J	RD 330 J 1/4W	89	
R193			RD14NB2E470J	RD 47 J 1/4W		
R194			RD14NB2E470J	RD 47 J 1/4W	89	
R195			RD14NB2E470J	RD 47 J 1/4W		
R196			RD14NB2E470J	RD 47 J 1/4W	89	
R197			RD14NB2E221J	RD 220 J 1/4W		
R198			RD14NB2E221J	RD 220 J 1/4W	89	
R199			RD14NB2E330J	RD 33 J 1/4W		
R200			RD14NB2E330J	RD 33 J 1/4W	89	
R201			RS14KB3D4R7J	FL-PROOF RS 4.7 J 2W		
R202			RS14KB3D4R7J	FL-PROOF RS 4.7 J 2W	89	
R301			RS14KB3D182J	FL-PROOF RS 1.8K J 2W		
R303	Δ		RD14NB2E1R0J	RD 1 J 1/4W	E9E3	
R303	Δ		RD14NB2E1R0J	RD 1 J 1/4W	7	
R303	Δ		RD14NB2E1R0J	RD 1 J 1/4W	8	
R303	Δ		RD14NB2E561J	RD 560 J 1/4W	K7P7Y1	
R303	Δ		RD14NB2E561J	RD 560 J 1/4W	K8P8	
R304	Δ		RS14KB3A103J	FL-PROOF RS 10K J 1W	E9E3	
R304	Δ		RS14KB3A103J	FL-PROOF RS 10K J 1W	78	
R304	Δ		RS14KB3A822J	FL-PROOF RS 8.2K J 1W	K7P7Y1	
R304	Δ		RS14KB3A822J	FL-PROOF RS 8.2K J 1W	K8P8	
R306	Δ		RD14NB2E101J	RD 100 J 1/4W		
R307	Δ		RD14NB2E822J	RD 8.2K J 1/4W		
R310,311			RS14KB3A680J	FL-PROOF RS 68 J 1W		
R314			RS14KB3A681J	FL-PROOF RS 680 J 1W		
R315,316	Δ		RD14NB2E100J	RD 10 J 1/4W	89	
R317			RS14KB3D122J	FL-PROOF RS 1.2K J 2W	E3K8P8	
R317			RS14KB3D122J	FL-PROOF RS 1.2K J 2W	K7P7E9	
R317			RS14KB3D122J	FL-PROOF RS 1.2K J 2W	78	
R317,318			RS14KB3D222J	FL-PROOF RS 2.2K J 2W	Y1	
R318			RS14KB3D152J	FL-PROOF RS 1.5K J 2W	E3K8P8	
R318			RS14KB3D152J	FL-PROOF RS 1.5K J 2W	K7P7E9	
R318			RS14KB3D152J	FL-PROOF RS 1.5K J 2W	78	
R321,322	Δ		RD14NB2E1R0J	RD 1 J 1/4W		
R325,326	Δ		RD14NB2E472J	RD 4.7K J 1/4W		
R331-333			RS14KB3D182J	FL-PROOF RS 1.8K J 2W		
R342			RS14KB3A100J	FL-PROOF RS 10 J 1W		
R343			RS14KB3A470J	FL-PROOF RS 47 J 1W		
R454			RS14KB3A391J	FL-PROOF RS 390 J 1W		
R476	Δ		RD14NB2E561J	RD 560 J 1/4W		

L : Scandinavia K : USA P : Canada R : Mexico C : China I : Malaysia
Y : PX(Far East,Hawaii) T : England E : Europe G : Germany V : China(Shanghai)
Y : AAFES(Europe) X : Australia Q : Russia H : Korea M : Other Areas Δ indicates safety critical components .

* New Parts
Parts without **Parts No.** are not supplied.
Les articles non mentionnés dans le **Parts No.** ne sont pas fournis.
Teile ohne **Parts No.** werden nicht geliefert.

12

Ref. No	Add-ress	New Parts	Parts No.	Description	Desti-nation	Re-marks
VR1 -5			R32-0032-05	SEMI FIXED VARIABLE RESISTOR		
VR6			R32-0032-05	SEMI FIXED VARIABLE RESISTOR	89	
Δ K1			S76-0134-05	MAGNETIC RELAY		
K2 -5			S76-0045-15	MAGNETIC RELAY	K6P6	
K2 -5			S76-0045-15	MAGNETIC RELAY	K7P7Y1	
K2 -5			S76-0045-15	MAGNETIC RELAY	K8P8	
K2 -5			S76-0098-05	MAGNETIC RELAY	E8E2	
K2 -5			S76-0098-05	MAGNETIC RELAY	E9E3	
K2 -5			S76-0098-05	MAGNETIC RELAY	7	
D1 -5			HSS104A	DIODE		
D1 -5			1SS133	DIODE		
D6			HSS104A	DIODE	89	
D6			1SS133	DIODE	89	
Δ D11 ,12			D5SBA20F03	DIODE		
Δ D11 ,12			TS6P03G-B	DIODE		
D13			HSS104A	DIODE		
D13			1SS133	DIODE		
Δ D14 ,15			1SR139-400	DIODE		
D16			HSS104A	DIODE		
D16			1SS133	DIODE		
D17			MTZJ16(B)	ZENER DIODE		
D17			RD16ES(B)	ZENER DIODE		
D18			MTZJ15(B)	ZENER DIODE		
D18			RD15ES(B)	ZENER DIODE		
D19			MTZJ16(B)	ZENER DIODE		
D19			RD16ES(B)	ZENER DIODE		
D20 ,21			MTZJ6.8(B)	ZENER DIODE		
D20 ,21			RD6.8ES(B)	ZENER DIODE		
D22			MTZJ5.1(B)	ZENER DIODE		
D22			RD5.1ES(B)	ZENER DIODE		
D23			MTZJ10(B)	ZENER DIODE	K6P6	
D23			MTZJ10(B)	ZENER DIODE	K7P7K8	
D23			MTZJ10(B)	ZENER DIODE	P8	
D23			MTZJ11(B)	ZENER DIODE	Y1	
D23			RD10ES(B)	ZENER DIODE	K6P6	
D23			RD10ES(B)	ZENER DIODE	K7P7K8	
D23			RD10ES(B)	ZENER DIODE	P8	
D23			RD11ES(B)	ZENER DIODE	Y1	
D23 ,24			MTZJ10(B)	ZENER DIODE	E8E2	
D23 ,24			MTZJ10(B)	ZENER DIODE	E9E3	
D23 ,24			RD10ES(B)	ZENER DIODE	7	
D23 ,24			RD10ES(B)	ZENER DIODE	E8E2	
D23 ,24			RD10ES(B)	ZENER DIODE	E9E3	
D23 ,24			RD10ES(B)	ZENER DIODE	7	
D24			MTZJ15(B)	ZENER DIODE	K6P6	
D24			MTZJ15(B)	ZENER DIODE	K7P7K8	
D24			MTZJ15(B)	ZENER DIODE	P8	
D24			MTZJ7.5(B)	ZENER DIODE	Y1	
D24			RD15ES(B)	ZENER DIODE	K6P6	
D24			RD15ES(B)	ZENER DIODE	K7P7K8	
D24			RD15ES(B)	ZENER DIODE	P8	
D24			RD7.5ES(B)	ZENER DIODE	Y1	
D25			MTZJ24(B)	ZENER DIODE	E3K8P8	
D25			MTZJ24(B)	ZENER DIODE	K7P7E9	

L : Scandinavia K : USA P : Canada R : Mexico C : China I : Malaysia
Y : PX(Far East,Hawaii) T : England E : Europe G : Germany V : China(Shanghai)
Y : AAFES(Europe) X : Australia Q : Russia H : Korea M : Other Areas Δ indicates safety critical components .

* New Parts
 Parts without **Parts No.** are not supplied.
 Les articles non mentionnés dans le **Parts No.** ne sont pas fournis.
 Teile ohne **Parts No.** werden nicht geliefert.

13

Ref. No	Add-ress	New Parts	Parts No.	Description	Desti-nation	Re-marks
D25			MTZJ24(B)	ZENER DIODE	78	
D25			MTZJ30(B)	ZENER DIODE	Y1	
D25			RD24ES(B)	ZENER DIODE	E3K8P8	
D25			RD24ES(B)	ZENER DIODE	K7P7E9	
D25			RD24ES(B)	ZENER DIODE	78	
D25			RD30ES(B)	ZENER DIODE	Y1	
D26			MTZJ5.1(B)	ZENER DIODE	E9E3	
D26			RD5.1ES(B)	ZENER DIODE	E9E3	
D27			1SS244	DIODE		
D28 ,29			HSS104A	DIODE		
D28 ,29			1SS133	DIODE		
D30			HSS104A	DIODE	89	
D30			1SS133	DIODE	89	
D32 -35			HSS104A	DIODE		
D32 -35			1SS133	DIODE		
D51 ,52			1SS244	DIODE		
D53 ,54			HSS104A	DIODE		
D53 ,54			1SS133	DIODE		
D55 ,56			1SS244	DIODE		
D57 ,58			HSS104A	DIODE		
D57 ,58			1SS133	DIODE		
D59			1SS244	DIODE		
D60			1SS244	DIODE		
D61			HSS104A	DIODE	89	
D61			1SS133	DIODE		
D63			MTZJ3.9(B)	ZENER DIODE		
D63			RD3.9ES(B)	ZENER DIODE		
D64			HSS104A	DIODE		
D64			1SS133	DIODE		
D65			MTZJ3.9(B)	ZENER DIODE		
D65			RD3.9ES(B)	ZENER DIODE		
D66			HSS104A	DIODE		
D66			1SS133	DIODE		
D67			MTZJ3.9(B)	ZENER DIODE		
D67			RD3.9ES(B)	ZENER DIODE		
D68			HSS104A	DIODE		
D68			1SS133	DIODE		
D69			MTZJ3.9(B)	ZENER DIODE		
D69			RD3.9ES(B)	ZENER DIODE		
D221			MTZJ11(B)	ZENER DIODE	89	
D221			RD11ES(B)	ZENER DIODE	89	
D602-604			HSS104A	DIODE		
D602-604			1SS133	DIODE		
D605-607			MTZJ7.5(B)	ZENER DIODE	9	
D605-607			RD7.5ES(B)	ZENER DIODE	9	
IC1			NJM4580L	ANALOGUE IC		
IC2			M61516FP	ANALOGUE IC		
IC3			BU4066BC	ANALOGUE IC	9	
IC4			NJM4565D	ANALOGUE IC	78	
IC5			LC4966	IC(CMOS LOGIC BILATERAL SW)	89	
IC6			NJM4580D-D	IC(OP AMP X2)	9	
Q1 -4			2SA992(F,E)	TRANSISTOR		
Q5 ,6			2SA1123(R,S)	TRANSISTOR		
Q7 -10			2SC2631(R,S)	TRANSISTOR		
Q11 ,12			TRAIT3KN	TRANSISTOR		

L : Scandinavia K : USA P : Canada R : Mexico C : China I : Malaysia
 Y : PX(Far East,Hawaii) T : England E : Europe G : Germany V : China(Shanghai)
 Y : AAFES(Europe) X : Australia Q : Russia H : Korea M : Other Areas Δ indicates safety critical components .

* New Parts
 Parts without **Parts No.** are not supplied.
 Les articles non mentionnés dans le **Parts No.** ne sont pas fournis.
 Teile ohne **Parts No.** werden nicht geliefert.

14

Ref. No	Add-ress	New Parts	Parts No.	Description	Desti-nation	Re-marks
Δ Q13 ,14			TRAIT3KP	TRANSISTOR		
Q21 -24			2SA992(F,E)	TRANSISTOR		
Q25 ,26			2SA1123(R,S)	TRANSISTOR		
Q27 -30			2SC2631(R,S)	TRANSISTOR		
Δ Q31 ,32			TRAIT3KN	TRANSISTOR		
Δ Q33 ,34			TRAIT3KP	TRANSISTOR		
Q41			2SA992(F,E)	TRANSISTOR	89	
Q42			2SA992(F,E)	TRANSISTOR		
Q43			2SA992(F,E)	TRANSISTOR	89	
Q44			2SA992(F,E)	TRANSISTOR		
Q45			2SA1123(R,S)	TRANSISTOR		
Q46			2SA1123(R,S)	TRANSISTOR	89	
Q47			2SC2631(R,S)	TRANSISTOR		
Q48			2SC2631(R,S)	TRANSISTOR	89	
Q49			2SC2631(R,S)	TRANSISTOR		
Q50			2SC2631(R,S)	TRANSISTOR	89	
Δ Q51 ,52			TRAIT3KN	TRANSISTOR		
Δ Q53 ,54			TRAIT3KP	TRANSISTOR		
Q301			KTC3200	TRANSISTOR		
Q302			DTC113ZSA	DIGITAL TRANSISTOR		
Q302			UN4219	DIGITAL TRANSISTOR		
Δ Q303			2SC3940A(R,S)	TRANSISTOR		
Δ Q304			2SB1640	TRANSISTOR		
Δ Q305			UN421N	DIGITAL TRANSISTOR		
Δ Q306			2SB1640	TRANSISTOR		
Δ Q307			2SD2525	TRANSISTOR		
Q308			2SA992(F,E)	TRANSISTOR		
Q309-312			KTC3200	TRANSISTOR		
Q313			UN421N	DIGITAL TRANSISTOR	E9E3	
Q331-335			2SC2878(B)	TRANSISTOR		
Q336			2SC2878(B)	TRANSISTOR	89	
Q337,338			2SC2878(B)	TRANSISTOR	78	
Q351			UN421N	DIGITAL TRANSISTOR	89	
Q352			DTC124ESA	DIGITAL TRANSISTOR	89	
Q352			UN4212	DIGITAL TRANSISTOR	89	
Q353-357			2SC1845(F,E)	TRANSISTOR		
Q358			2SC1845(F,E)	TRANSISTOR	89	
Q359			2SA992(F,E)	TRANSISTOR		
Q360,361			2SC1845(F,E)	TRANSISTOR		
Q362			2SA992(F,E)	TRANSISTOR		
Q363,364			2SC1845(F,E)	TRANSISTOR		
Q365			2SA992(F,E)	TRANSISTOR		
Q602-604			2SC1845(F,E)	TRANSISTOR		
Q605,606			2SC2878(B)	TRANSISTOR		
Q607			2SA992(F,E)	TRANSISTOR		
Q608,609			DTC124ESA	DIGITAL TRANSISTOR	9	
Q608,609			UN4212	DIGITAL TRANSISTOR	9	
DISPLAY (X14-7630-10)						
D734			B30-2545-05	LED(RED3(160))		
D741-745			B30-2545-05	LED(RED3(160))	K6P6	
D741-745			B30-2545-05	LED(RED3(160))	K7P7Y1	
D741-745			B30-2545-05	LED(RED3(160))	K8P8	
D741-745		*	B30-2651-05	LED(RED,D3,40DEG.)	E8E2	
D741-745		*	B30-2651-05	LED(RED,D3,40DEG.)	E9E3	

L : Scandinavia K : USA P : Canada R : Mexico C : China I : Malaysia
 Y : PX(Far East,Hawaii) T : England E : Europe G : Germany V : China(Shanghai)
 Y : AAFES(Europe) X : Australia Q : Russia H : Korea M : Other Areas Δ indicates safety critical components .

KRF-V7070D/N8070D/X9070D/NR-7060/7070/7080
PARTS LIST

* New Parts
Parts without **Parts No.** are not supplied.
Les articles non mentionnés dans le **Parts No.** ne sont pas fournis.
Teile ohne **Parts No.** werden nicht geliefert.

15

Ref. No	Add-ress	New Parts	Parts No.	Description	Desti-nation	Re-marks
D741-745 D746-752 D746-752 D753 D754		*	B30-2651-05 B30-2567-05 * B30-2651-05 B30-2545-05 B30-2567-05	LED(RED,D3,40DEG.) LED(RED(80) HI-BR) LED(RED,D3,40DEG.) LED(RED3(160)) LED(RED(80) HI-BR)	7	
D754 D755 D755		*	B30-2651-05 B30-2545-05 * B30-2651-05	LED(RED,D3,40DEG.) LED(RED3(160)) LED(RED,D3,40DEG.)		
C101 C103 C104 C105 C201			CC45FSL1H101J CK73GB1H103K CC73GCH1H101J CC45FCH1H101J CE04KW2A101M	CERAMIC 100PF J CHIP C 0.010UF K CHIP C 100PF J CERAMIC 100PF J ELECTRO 100UF 100WV	E9E3	
C202 C401 C402 C403 C404-407			CC73GCH1H180J CK45FE2H103P CE04KW1E222M CE04KW1E102M CK73GB1H103K	CHIP C 18PF J CERAMIC 0.010UF P ELECTRO 2200UF 25WV ELECTRO 1000UF 25WV CHIP C 0.010UF K	78	
C408,409 C410 C411 C451 C452			CE04KW1E470M CC73GCH1H680J CC73GCH1H820J CK45FF1H103Z CQ93FMG1H104J	ELECTRO 47UF 25WV CHIP C 68PF J CHIP C 82PF J CERAMIC 0.010UF Z MYLAR 0.10UF J	K6P6	
C452 C452 C452 C452 C452			CQ93FMG1H104J CQ93FMG1H104J CQ93FMG1H393J CQ93FMG1H393J CQ93FMG1H393J	MYLAR 0.10UF J MYLAR 0.10UF J MYLAR 0.039UF J MYLAR 0.039UF J MYLAR 0.039UF J	K7P7K8 P8 E8E2 E9E3 7	
C452 C453 C453 C453			CQ93FMG1H683J CE04KW1C332M CE04KW1C332M CE04KW1C332M CE04KW1E332M	MYLAR 0.068UF J ELECTRO 3300UF 16WV ELECTRO 3300UF 16WV ELECTRO 3300UF 16WV ELECTRO 3300UF 25WV	Y1 K6P6 K7P7K8 P8 E8E2	
C453 C453 C454 C455 C456,457			CE04KW1E332M CE04KW1E332M CE04LW1H100M CE04LW0J222M CK45FF1H103Z	ELECTRO 3300UF 25WV ELECTRO 3300UF 25WV ELECTRO 10UF 50WV ELECTRO 2200UF 6.3WV CERAMIC 0.010UF Z	Y1E9E3 7 Y1	
C458 C459 C501-504 C505,506 C507,508			CE04LW1H100M CE04LW1H010M CC45FCH1H101J CK45FB1H102K CC45FCH1H101J	ELECTRO 10UF 50WV ELECTRO 1.0UF 50WV CERAMIC 100PF J CERAMIC 1000PF K CERAMIC 100PF J		
C509 C510 C511 C601-606 C607			CK45FB1H471K CC73GCH1H101J CC45FCH1H101J CC45FSL1H470J CC45FSL1H470J	CERAMIC 470PF K CHIP C 100PF J CERAMIC 100PF J CERAMIC 47PF J CERAMIC 47PF J	9	
C608-611 C651-654 C655,656 C657,658 C659-662			CE04LW1E470M CC45FSL1H470J CC45FSL1H470J CC45FSL1H470J CC45FSL1H470J	ELECTRO 47UF 25WV CERAMIC 47PF J CERAMIC 47PF J CERAMIC 47PF J CERAMIC 47PF J	89 89	
C663			CK45FF1H103Z	CERAMIC 0.010UF Z		

L : Scandinavia K : USA P : Canada R : Mexico C : China I : Malaysia
Y : PX(Far East,Hawaii) T : England E : Europe G : Germany V : China(Shanghai)
Y : AAFES(Europe) X : Australia Q : Russia H : Korea M : Other Areas Δ indicates safety critical components.

* New Parts
Parts without **Parts No.** are not supplied.
Les articles non mentionnés dans le **Parts No.** ne sont pas fournis.
Teile ohne **Parts No.** werden nicht geliefert.

16

Ref. No	Add-ress	New Parts	Parts No.	Description	Desti-nation	Re-marks
C664 C665 C666 C667 C668			CE04LW1E470M CK45FF1H103Z CE04LW1E470M CK45FF1H103Z CE04LW1E470M	ELECTRO 47UF 25WV CERAMIC 0.010UF Z ELECTRO 47UF 25WV CERAMIC 0.010UF Z ELECTRO 47UF 25WV	89 89	
C669 C670 C671 C672 C673			CK45FF1H103Z CE04LW1E470M CE04LW1E470M CK45FF1H103Z CE04LW1E470M	CERAMIC 0.010UF Z ELECTRO 47UF 25WV ELECTRO 47UF 25WV CERAMIC 0.010UF Z ELECTRO 47UF 25WV	89 89	
C674-677 C693 C701 C702 C703,704			CE04LW1H100M CC45FSL1H101J CC73GCH1H221J CE04LW1H101M CC73GCH1H102J	ELECTRO 10UF 50WV CERAMIC 100PF J CHIP C 220PF J ELECTRO 100UF 50WV CHIP C 1000PF J		
C705 C741 C761,762 C763,764 C765,766			CC73GCH1H181J CK73EF1E105Z CK73GB1H103K CK45FF1H103Z CK73GB1H103K	CHIP C 180PF J CHIP C 1.0UF Z CHIP C 0.010UF K CERAMIC 0.010UF Z CHIP C 0.010UF K		
C777 C778 C779 C780 C791			CK45FB1H102K CC45FCH1H101J CE04LW1A101M CC73GCH1H270J CE04RW0J470M	CERAMIC 1000PF K CERAMIC 100PF J ELECTRO 100UF 10WV CHIP C 27PF J ELECTRO 47UF 6.3WV		
C792 C793,794 C811 C811 C811			CE04LW1H220M CK45FF1H103Z CK45FF1H103Z CK45FF1H103Z CK45FF1H103Z	ELECTRO 22UF 50WV CERAMIC 0.010UF Z CERAMIC 0.010UF Z CERAMIC 0.010UF Z CERAMIC 0.010UF Z	E8E2 E9E3 7	
C812,813 C812,813 C812,813 C814 C814			CC45FCH1H270J CC45FCH1H270J CC45FCH1H270J CC45FCH1H101J CC45FCH1H101J	CERAMIC 27PF J CERAMIC 27PF J CERAMIC 27PF J CERAMIC 100PF J CERAMIC 100PF J	E8E2 E9E3 7 E8E2 E9E3	
C814 C815 C815 C815 C816			CC45FCH1H101J CE04LW1E470M CE04LW1E470M CE04LW1E470M CK45FB1H561K	CERAMIC 100PF J ELECTRO 47UF 25WV ELECTRO 47UF 25WV ELECTRO 47UF 25WV CERAMIC 560PF K	7 E8E2 E9E3 7 E8E2	
C816 C816 C817 C817 C817			CK45FB1H561K CK45FB1H561K CK45FF1H103Z CK45FF1H103Z CK45FF1H103Z	CERAMIC 560PF K CERAMIC 560PF K CERAMIC 0.010UF Z CERAMIC 0.010UF Z CERAMIC 0.010UF Z	E9E3 7 E8E2 E9E3 7	
C818 C818 C818 C819 C819			CC45FSL1H271J CC45FSL1H271J CC45FSL1H271J CE04LW1H2R2M CE04LW1H2R2M	CERAMIC 270PF J CERAMIC 270PF J CERAMIC 270PF J ELECTRO 2.2UF 50WV ELECTRO 2.2UF 50WV	E8E2 E9E3 7 E8E2 E9E3	
C819 C831 C832 C833 C841			CE04LW1H2R2M CK45FF1H103Z CE04LW1H2R2M CK45FF1H103Z CE04EW0J102M	ELECTRO 2.2UF 50WV CERAMIC 0.010UF Z ELECTRO 2.2UF 50WV CERAMIC 0.010UF Z ELECTRO 1000UF 6.3WV	7 Y1 Y1 Y1 K6P6	

L : Scandinavia K : USA P : Canada R : Mexico C : China I : Malaysia
Y : PX(Far East,Hawaii) T : England E : Europe G : Germany V : China(Shanghai)
Y : AAFES(Europe) X : Australia Q : Russia H : Korea M : Other Areas Δ indicates safety critical components.

PARTS LIST

KRF-V7070D/N8070D/X9070D/VR-7060/7070/7080

* New Parts
 Parts without **Parts No.** are not supplied.
 Les articles non mentionnés dans le **Parts No.** ne sont pas fournis.
 Teile ohne **Parts No.** werden nicht geliefert.

17

Ref. No	Add-ress	New Parts	Parts No.	Description	Desti-nation	Re-marks
C841			CE04EWOJ102M	ELECTRO 1000UF 6.3WV	K7P7K8	
C841			CE04EWOJ102M	ELECTRO 1000UF 6.3WV	P8	
C842			C90-1826-05	BACKUP-C 0.047F 5.5WV	E8E2	
C842			C90-1826-05	BACKUP-C 0.047F 5.5WV	Y1E9E3	
C842			C90-1826-05	BACKUP-C 0.047F 5.5WV	7	
C843			CE04LW1H010M	ELECTRO 1.0UF 50WV		
C844			CK45FF1H103Z	CERAMIC 0.010UF Z		
C845			CK73GB1H103K	CHIP C 0.010UF K		
C851			CE04LW1H100M	ELECTRO 10UF 50WV		
C852-855			CC45FSL1H221J	CERAMIC 220PF J		
C856,857			CK45FF1H103Z	CERAMIC 0.010UF Z		
C858			CE04LW1A101M	ELECTRO 100UF 10WV		
C907			CK73GB1H103K	CHIP C 0.010UF K		
C908			CK45FF1H103Z	CERAMIC 0.010UF Z		
C909			CK73GB1H103K	CHIP C 0.010UF K	Y1	
Δ J2			E03-0148-05	AC OUTLET	K6P6	
Δ J2			E03-0148-05	AC OUTLET	K7P7Y1	
Δ J2			E03-0148-05	AC OUTLET	K8P8	
Δ J3		*	E03-0398-05	AC OUTLET	E8E2	
Δ J3		*	E03-0398-05	AC OUTLET	E9E3	
Δ J3		*	E03-0398-05	AC OUTLET	7	
J20			E63-1251-05	PIN JACK		
J21			E56-0033-05	CYLINDRICAL RECEPTACLE		
J61 ,62		*	E63-1293-05	PIN JACK		
J63		*	E63-1313-05	PIN JACK	9	
J65 ,66			E56-0040-05	CYLINDRICAL RECEPTACLE	89	
J65 ,66		*	E56-0050-05	CYLINDRICAL RECEPTACLE	89	
J67			E56-0040-05	CYLINDRICAL RECEPTACLE		
J67		*	E56-0050-05	CYLINDRICAL RECEPTACLE		
J68			E56-0042-05	CYLINDRICAL RECEPTACLE	7	
J68		*	E56-0051-05	CYLINDRICAL RECEPTACLE	7	
Δ F1			F05-4025-05	FUSE (SEMKO) (250V T4A L)	E8E2	
Δ F1			F05-4025-05	FUSE (SEMKO) (250V T4A L)	Y1E9E3	
Δ F1			F05-4025-05	FUSE (SEMKO) (250V T4A L)	7	
Δ F1			F50-0078-05	FUSE(5X20)	K6P6	
Δ F1			F50-0078-05	FUSE(5X20)	K7P7K8	
Δ F1			F50-0078-05	FUSE(5X20)	P8	
Δ F2			F06-1022-05	FUSE (SEMKO) (250V T1AL)	E8E2	
Δ F2			F06-1022-05	FUSE (SEMKO) (250V T1AL)	Y1E9E3	
Δ F2			F06-1022-05	FUSE (SEMKO) (250V T1AL)	7	
Δ F3			F05-4025-05	FUSE (SEMKO) (250V T4A L)	Y1	
CN3 ,4			J13-0075-05	FUSE CLIP	Y1	
CN11,12			J13-0075-05	FUSE CLIP		
CN21,22			J13-0075-05	FUSE CLIP	E8E2	
CN21,22			J13-0075-05	FUSE CLIP	Y1E9E3	
CN21,22			J13-0075-05	FUSE CLIP	7	
Δ T1			L07-2761-05	POWER TRANSFORMER	E8E2	
Δ T1			L07-2761-05	POWER TRANSFORMER	E9E3	
Δ T1			L07-2761-05	POWER TRANSFORMER	7	
Δ T1			L07-2805-05	POWER TRANSFORMER	Y1	
Δ T1			L07-2809-05	POWER TRANSFORMER	K6P6	
Δ T1			L07-2809-05	POWER TRANSFORMER	K7P7K8	
Δ T1			L07-2809-05	POWER TRANSFORMER	P8	
X701			L78-0725-05	RESONATOR (8.38MHZ)		

L : Scandinavia K : USA P : Canada R : Mexico C : China I : Malaysia
 Y : PX(Far East,Hawaii) T : England E : Europe G : Germany V : China(Shanghai)
 Y : AAFES(Europe) X : Australia Q : Russia H : Korea M : Other Areas Δ indicates safety critical components .

* New Parts
 Parts without **Parts No.** are not supplied.
 Les articles non mentionnés dans le **Parts No.** ne sont pas fournis.
 Teile ohne **Parts No.** werden nicht geliefert.

18

Ref. No	Add-ress	New Parts	Parts No.	Description	Desti-nation	Re-marks
X811			L77-2002-05	CRYSTAL RESONATOR(4.332MHZ)	E8E2	
X811			L77-2002-05	CRYSTAL RESONATOR(4.332MHZ)	E9E3	
X811			L77-2002-05	CRYSTAL RESONATOR(4.332MHZ)	7	
R120			RK73GB1J102J	CHIP R 1.0K J 1/16W		
R201			RD14NB2E472J	RD 4.7K J 1/4W		
Δ R410			RS14KB3D181J	FL-PROOF RS 180 J 2W		
Δ R453			RD14NB2E1R0J	RD 1 J 1/4W		
Δ R454			RD14NB2E150J	RD 15 J 1/4W	Y1	
Δ R454			RD14NB2E270J	RD 27 J 1/4W	E3K8P8	
Δ R454			RD14NB2E270J	RD 27 J 1/4W	K7P7E9	
Δ R454			RD14NB2E270J	RD 27 J 1/4W	7	
Δ R457			R92-1844-05	CARBON 3.3M J 1/2W	8	
Δ R457			R92-1844-05	CARBON 3.3M J 1/2W	K6P6	
Δ R457			R92-1844-05	CARBON 3.3M J 1/2W		
Δ R457			R92-1844-05	CARBON 3.3M J 1/2W		
Δ R458			RD14NB2E120J	RD 12 J 1/4W		
Δ R671			RS14KB3A180J	FL-PROOF RS 18 J 1W		
Δ R674			RS14KB3A470J	FL-PROOF RS 47 J 1W	Y1	
R776			RD14NB2E100J	RD 10 J 1/4W		
R779			RK73GB1J333J	CHIP R 33K J 1/16W		
R780			RD14NB2E100J	RD 10 J 1/4W		
R782			RK73GB1J303J	CHIP R 30K J 1/16W		
R801 ,802			RK73GB1J331J	CHIP R 330 J 1/16W		
R803			RK73GB1J104J	CHIP R 100K J 1/16W		
R805			RK73GB1J104J	CHIP R 100K J 1/16W		
R834			RD14NB2E102J	RD 1.0K J 1/4W	Y1	
R894			RK73GB1J101J	CHIP R 100 J 1/16W		
R896-898			RK73GB1J101J	CHIP R 100 J 1/16W		
R910,911			RK73GB1J104J	CHIP R 100K J 1/16W		
R922-924			RK73GB1J101J	CHIP R 100 J 1/16W		
R926			RK73GB1J101J	CHIP R 100 J 1/16W		
R935			RK73GB1J101J	CHIP R 100 J 1/16W		
R938,939			RK73GB1J101J	CHIP R 100 J 1/16W		
R951,952			RK73GB1J104J	CHIP R 100K J 1/16W		
R967-969			RK73GB1J104J	CHIP R 100K J 1/16W		
R970			RK73GB1J153J	CHIP R 15K J 1/16W		
R971,972			RK73GB1J104J	CHIP R 100K J 1/16W		
R977			RK73GB1J123J	CHIP R 12K J 1/16W	Y1	
R977			RK73GB1J273J	CHIP R 27K J 1/16W	E8E2	
R977			RK73GB1J273J	CHIP R 27K J 1/16W	E9E3	
R977			RK73GB1J273J	CHIP R 27K J 1/16W	7	
R993			RK73GB1J101J	CHIP R 100 J 1/16W		
Δ R997			RD14NB2E1R0J	RD 1 J 1/4W		
K451			S76-0107-05	MAGNETIC RELAY		
K451			S76-0107-05	MAGNETIC RELAY		
K451			S76-0107-05	MAGNETIC RELAY		
K451			S76-0110-05	MAGNETIC RELAY		
K451			S76-0110-05	MAGNETIC RELAY		
Δ K451			S76-0110-05	MAGNETIC RELAY		
S1			S62-0001-05	SLIDE SWITCH		
S2			S68-0142-05	PUSH SWITCH		
S2			S68-0142-05	PUSH SWITCH		
S2			S68-0142-05	PUSH SWITCH		
S701-725			S70-0086-05	TACT SWITCH		

L : Scandinavia K : USA P : Canada R : Mexico C : China I : Malaysia
 Y : PX(Far East,Hawaii) T : England E : Europe G : Germany V : China(Shanghai)
 Y : AAFES(Europe) X : Australia Q : Russia H : Korea M : Other Areas Δ indicates safety critical components .

KRF-V7070D/N8070D/X9070D/NR-7060/7070/7080
PARTS LIST

* New Parts
Parts without **Parts No.** are not supplied.
Les articles non mentionnés dans le **Parts No.** ne sont pas fournis.
Teile ohne **Parts No.** werden nicht geliefert.

19

Ref. No	Add-ress	New Parts	Parts No.	Description	Desti-nation	Re-marks
S731-733			S70-0086-05	TACT SWITCH		
S761,762 S763			T99-0663-05 T99-0664-05	ROTARY ENCODER ROTARY ENCODER		
D201 D201 D202 D202 D401			MTZJ20(B) RD20ES(B) MTZJ30(B) RD30ES(B) D2SBA20F03	ZENER DIODE ZENER DIODE ZENER DIODE ZENER DIODE DIODE		
D451,452 D451,452 D453 D454 D454			HSS104A 1SS133 S1ZB20(4101) HSS104A 1SS133	DIODE DIODE DIODE DIODE DIODE		
D455 D501-504 D501-504 D652 D652			RB721Q HSS104A 1SS133 HSS104A 1SS133	DIODE DIODE DIODE DIODE DIODE		
D655,656 D655,656 D776 D776 D791			MTZJ5.6(B) RD5.6ES(B) MTZJ5.1(B) RD5.1ES(B) HSS104A	ZENER DIODE ZENER DIODE ZENER DIODE ZENER DIODE DIODE		
D791 D801-806 D801-806 D831 D831			1SS133 HSS104A 1SS133 HSS104A 1SS133	DIODE DIODE DIODE DIODE DIODE	Y1 Y1	
D841 D842 D842 D843 D844			RB721Q HSS104A 1SS133 RB721Q HSS104A	DIODE DIODE DIODE DIODE DIODE		
D844 D846 D846 D961-964 D961-964			1SS133 HSS104A 1SS133 HSS104A 1SS133	DIODE DIODE DIODE DIODE DIODE		
ED78 IC45 IC65 IC74 IC78			HNA-16MM36T BA05T LA79510M BU2090 LC75711NED	FLUORESCENT INDICATOR TUBE ANALOGUE IC ANALOGUE IC ANALOGUE IC MOS-IC		
IC79 IC81 IC81 IC81 IC83			XC6202P502PR BU1923 BU1923 BU1923 S-80840CNY	ANALOGUE IC ANALOGUE IC ANALOGUE IC ANALOGUE IC ANALOGUE IC	E8E2 E9E3 7 Y1	
IC84 IC90 IC90 IC401 IC402		*	S-80840CNY MN101C49GGP MN101C49GGS KIA7812API KIA7912PI	ANALOGUE IC MI-COM IC MI-COM IC ANALOGUE IC ANALOGUE IC	9 78	

L : Scandinavia K : USA P : Canada R : Mexico C : China I : Malaysia
Y : PX(Far East,Hawaii) T : England E : Europe G : Germany V : China(Shanghai)
Y : AAFES(Europe) X : Australia Q : Russia H : Korea M : Other Areas Δ indicates safety critical components .

* New Parts
Parts without **Parts No.** are not supplied.
Les articles non mentionnés dans le **Parts No.** ne sont pas fournis.
Teile ohne **Parts No.** werden nicht geliefert.

20

Ref. No	Add-ress	New Parts	Parts No.	Description	Desti-nation	Re-marks
Q65 Q66 Q201 Q451 Q451			2SD2525 2SB1640 2SD2012 2SC1740S(Q,R) 2SC2785(F,E)	TRANSISTOR TRANSISTOR TRANSISTOR TRANSISTOR TRANSISTOR		
Q731 Q731 Q776 Q776 Q777,778			DTC113ZSA UN4219 2SC1740S(Q,R) 2SC2785(F,E) DTC124ESA	DIGITAL TRANSISTOR DIGITAL TRANSISTOR TRANSISTOR TRANSISTOR DIGITAL TRANSISTOR		
Q777,778 Q841 Q841 Q842 Q842			UN4212 2SC1740S(Q,R) 2SC2785(F,E) 2SA1175(F,E) 2SA933AS(Q,R)	DIGITAL TRANSISTOR TRANSISTOR TRANSISTOR TRANSISTOR TRANSISTOR		
Q843 Q843 TH1			DTC113ZSA UN4219 MF-R090	DIGITAL TRANSISTOR DIGITAL TRANSISTOR THERMISTOR		
A791			W02-2769-05	ELECTRIC CIRCUIT MODULE		
SUB (X25-6490-13) EXCEPT KRF-V7070D/D-S						
C101-109 C110-115 C116 C117 C118			CC45FSL1H221J CE04LW1E470M CE04LW1H220M CE04LW1E470M CE04LW1A471M	CERAMIC ELECTRO ELECTRO ELECTRO ELECTRO	220PF 47UF 22UF 47UF 470UF	J 25WV 50WV 25WV 10WV
C119 C120 C121 C122 C123			CE04LW1H220M CE04LW1E470M CE04LW1A471M CE04LW1H220M CE04LW1E470M	ELECTRO ELECTRO ELECTRO ELECTRO ELECTRO	22UF 47UF 470UF 22UF 47UF	50WV 25WV 10WV 50WV 25WV
C124 C125 C126 C127-129 C201			CE04LW1A471M CK45FF1H103Z CE04LW1E470M CC45FCH1H270J CE04LW1H100M	ELECTRO CERAMIC ELECTRO CERAMIC ELECTRO	470UF 0.010UF 47UF 27PF 10UF	10WV Z 25WV J 50WV
C201 C202 C202 C205 C205			CE04LW1H100M CK45FF1H103Z CK45FF1H103Z CK45FF1H103Z CK45FF1H103Z	ELECTRO CERAMIC CERAMIC CERAMIC CERAMIC	10UF 0.010UF 0.010UF 0.010UF 0.010UF	50WV Z Z Z Z
C207 C207 C208 C208 C208 C209			CE04LW1A101M CE04LW1A101M CE04LW1A221M CE04LW1A221M CK45FF1H103Z	ELECTRO ELECTRO ELECTRO ELECTRO CERAMIC	100UF 100UF 220UF 220UF 0.010UF	10WV 10WV 10WV 10WV Z
C209 C210 C210 C210 C211-213 C211-213			CK45FF1H103Z CC45FSL1H221J CC45FSL1H221J CC45FSL1H101J CC45FSL1H101J	CERAMIC CERAMIC CERAMIC CERAMIC CERAMIC	0.010UF 220PF 220PF 100PF 100PF	Z J J J J
C214,215 C214,215 C216 C216			CK45FF1H103Z CK45FF1H103Z CE04LW1H010M CE04LW1H010M	CERAMIC CERAMIC ELECTRO ELECTRO	0.010UF 0.010UF 1.0UF 1.0UF	Z Z 50WV 50WV

L : Scandinavia K : USA P : Canada R : Mexico C : China I : Malaysia
Y : PX(Far East,Hawaii) T : England E : Europe G : Germany V : China(Shanghai)
Y : AAFES(Europe) X : Australia Q : Russia H : Korea M : Other Areas Δ indicates safety critical components .

* New Parts
 Parts without **Parts No.** are not supplied.
 Les articles non mentionnés dans le **Parts No.** ne sont pas fournis.
 Teile ohne **Parts No.** werden nicht geliefert.

21

Ref. No	Add-ress	New Parts	Parts No.	Description	Desti-nation	Re-marks
C301-310			CC45FSL1H221J	CERAMIC 220PF	J	9
C311-313			CK45FB1H332K	CERAMIC 3300PF	K	
C315-317			CC45FSL1H101J	CERAMIC 100PF	J	
C401-406			CE04KW1H220M	ELECTRO 22UF	50WV	9
C407-412			CC45FSL1H221J	CERAMIC 220PF	J	9
C419			CE04KW1E221M	ELECTRO 220UF	25WV	9
C420			CE04KW1E101M	ELECTRO 100UF	25WV	9
C425,426			CC45FCH1H101J	CERAMIC 100PF	J	9
C427-430			CC45FCH1H100D	CERAMIC 10PF	D	9
C431-436			CE04KW1E470M	ELECTRO 47UF	25WV	9
C437,438			CE04HW1E220M	NP-ELEC 22UF	25WV	9
C439,440			CE04KW1E470M	ELECTRO 47UF	25WV	9
C441,442			CE04KW1A101M	ELECTRO 100UF	10WV	9
C443-446			CE04KW1H220M	ELECTRO 22UF	50WV	9
C447			CE04LW1H100M	ELECTRO 10UF	50WV	9
C448			CE04KW2A3R3M	ELECTRO 3.3UF	100WV	9
C449,450			CE04KW1H220M	ELECTRO 22UF	50WV	9
C451			CE04KW1E221M	ELECTRO 220UF	25WV	9
C452			CE04KW1H220M	ELECTRO 22UF	50WV	9
C453,454			CC45FSL1H221J	CERAMIC 220PF	J	9
C457			CQ93FMG1H392J	MYLAR 3900PF	J	9
C458			CC45FCH1H100D	CERAMIC 10PF	D	9
C459			CC45FSL1H470J	CERAMIC 47PF	J	9
CN301			E40-8483-05	FLAT CABLE CONNECTOR		9
J101		*	E63-1249-05	PIN JACK	Y1E9E3	8
J101		*	E63-1315-05	PIN JACK	K7P7K8	P8
J101		*	E63-1315-05	PIN JACK	P8	8
J101		*	E63-1315-05	PIN JACK	P8	8
J102		*	E63-1250-05	PIN JACK	Y1E9E3	8
J102		*	E63-1316-05	PIN JACK	K7P7K8	P8
J102		*	E63-1316-05	PIN JACK	P8	8
J102		*	E63-1316-05	PIN JACK	8	8
J201		*	E11-0389-05	MINIATURE PHONE JACK(3.5 STERE)	K7P7K8	P8
J201		*	E11-0389-05	MINIATURE PHONE JACK(3.5 STERE)	P8	P8
J202		*	E11-0291-05	MINIATURE PHONE JACK(2P)	K7P7K8	P8
J202		*	E11-0291-05	MINIATURE PHONE JACK(2P)	P8	P8
J301		*	E70-0150-05	SCREW TERMINAL BOARD		9
J302		*	E63-1246-05	PIN JACK		9
J303		*	E63-1248-05	PIN JACK		9
L202		*	L92-0017-05	FERRITE CORE	K7P7K8	P8
L202		*	L92-0017-05	FERRITE CORE	P8	P8
R213,214		*	RD14NB2E471J	RD 470 J 1/4W	K7P7K8	P8
R213,214		*	RD14NB2E471J	RD 470 J 1/4W	P8	P8
R217		*	RD14NB2E471J	RD 470 J 1/4W	K7P7K8	P8
R217		*	RD14NB2E471J	RD 470 J 1/4W	P8	P8
R425		*	RD14NB2E561J	RD 560 J 1/4W	9	9
R434		*	RD14GB2E150J	FL-PROOF RD 15 J 1/4W	9	9
R450		*	RD14GB2E561J	FL-PROOF RD 560 J 1/4W	9	9
R451		*	RD14NB2E102J	RD 1.0K J 1/4W	9	9
R452		*	RD14GB2E150J	FL-PROOF RD 15 J 1/4W	9	9
D203-206			HSS104A	DIODE	K7P7K8	P8
D203-206			HSS104A	DIODE	P8	P8
D203-206			1SS133	DIODE	K7P7K8	P8

L : Scandinavia K : USA P : Canada R : Mexico C : China I : Malaysia
 Y : PX(Far East,Hawaii) T : England E : Europe G : Germany V : China(Shanghai)
 Y : AAFES(Europe) X : Australia Q : Russia H : Korea M : Other Areas Δ indicates safety critical components .

* New Parts
 Parts without **Parts No.** are not supplied.
 Les articles non mentionnés dans le **Parts No.** ne sont pas fournis.
 Teile ohne **Parts No.** werden nicht geliefert.

22

Ref. No	Add-ress	New Parts	Parts No.	Description	Desti-nation	Re-marks
D203-206			1SS133	DIODE		P8
D401			MTZJ3.9(B)	ZENER DIODE		9
D401			RD3.9ES(B)	ZENER DIODE		9
D402			MTZJ5.1(B)	ZENER DIODE		9
D402			RD5.1ES(B)	ZENER DIODE		9
IC101			NJM2284D	ANALOGUE IC		
IC102			BA7666FS	ANALOGUE IC		
IC201			BA05T	ANALOGUE IC		K7P7K8
IC201			BA05T	ANALOGUE IC		P8
IC202			TC74HC00AP	IC(2INPUT NAND GATE)		K7P7K8
IC202			TC74HC00AP	IC(2INPUT NAND GATE)		P8
IC401			NJM4580D-D	IC(OP AMP X2)		9
IC402			NJM4565D-D	IC(OP AMP X2)		9
IC403			NJM4580D-D	IC(OP AMP X2)		9
IC404			NJM4565D-D	IC(OP AMP X2)		9
Q101			DTC124ESA	DIGITAL TRANSISTOR		
Q101			UN4212	DIGITAL TRANSISTOR		
Q203			KTC3199(Y,GR)	TRANSISTOR		K7P7K8
Q203			KTC3199(Y,GR)	TRANSISTOR		P8
Q203			2SC1740S(Q,R)	TRANSISTOR		K7P7K8
Q203			2SC1740S(Q,R)	TRANSISTOR		P8
Q203			2SC2785(F,E)	TRANSISTOR		K7P7K8
Q204			KTA1267(Y,GR)	TRANSISTOR		P8
Q204			KTA1267(Y,GR)	TRANSISTOR		P8
Q204			2SA1175(F,E)	TRANSISTOR		K7P7K8
Q204			2SA1175(F,E)	TRANSISTOR		P8
Q204			2SA933AS(Q,R)	TRANSISTOR		K7P7K8
Q204			2SA933AS(Q,R)	TRANSISTOR		P8
Q301-320			2SC2878(B)	TRANSISTOR		9
Q401,402			DTA124ESA	DIGITAL TRANSISTOR		9
Q401,402			UN4112	DIGITAL TRANSISTOR		9
Q403-408			2SC2878(B)	TRANSISTOR		9
Q409			DTA124ESA	DIGITAL TRANSISTOR		9
Q409			UN4112	DIGITAL TRANSISTOR		9
Q411,412			2SC2878(B)	TRANSISTOR		9

L : Scandinavia K : USA P : Canada R : Mexico C : China I : Malaysia
 Y : PX(Far East,Hawaii) T : England E : Europe G : Germany V : China(Shanghai)
 Y : AAFES(Europe) X : Australia Q : Russia H : Korea M : Other Areas Δ indicates safety critical components .

KRF-V7070D/N8070D/X9070D/NR-7060/7070/7080
PARTS LIST

KRF-V7070D/V8070D/X9070D/VR-7060/7070/7080

PARTS LIST

MODEL		ABBRI.	SURROUND	AUDIO	DISPLAY	SUB	
KRF-V7070D	Y05-4682-70	E7	7	X08-3130-10	X09-6762-73	X14-7632-73	-
KRF-V7070D-S	Y05-4682-71	E1		X08-3130-10	X09-6762-73	X14-7632-73	-
VR-7060	Y05-4690-10	K6	8	X08-3130-11	X09-6760-11	X14-7630-11	X25-6490-13
VR-7060	Y05-4691-01	P6		X08-3130-11	X09-6760-11	X14-7630-11	X25-6490-13
KRF-V8070D	Y05-4692-71	E8		X08-3130-11	X09-6762-72	X14-7632-72	X25-6490-13
KRF-V8070D-S	Y05-4692-72	E2		X08-3130-11	X09-6762-72	X14-7632-72	X25-6490-13
KRF-X9070D	Y05-4702-91	Y1	9	X08-3130-23	X09-6762-91	X14-7632-91	X25-6492-72
KRF-X9070D	Y05-4702-71	E9		X08-3130-12	X09-6762-71	X14-7632-71	X25-6492-72
KRF-X9070D-S	Y05-4702-72	E3		X08-3130-12	X09-6762-71	X14-7632-71	X25-6492-72
VR-7070	Y05-4700-10	K7		X08-3130-12	X09-6760-10	X14-7630-10	X25-6490-14
VR-7070	Y05-4701-01	P7		X08-3130-12	X09-6760-10	X14-7630-10	X25-6490-14
VR-7080	Y05-4700-11	K8		X08-3130-12	X09-6760-10	X14-7630-10	X25-6490-14
VR-7080	Y05-4701-02	P8		X08-3130-12	X09-6760-10	X14-7630-10	X25-6490-14

HOW TO READ THE PARTS LIST

ABBREVIATION OF MODEL AND MASS PRODUCTION'S DESTINATIONS

MODEL	ABB.	Australia	Canada	China	England	Europe	Germany	Korea	Malaysia
			P			E			
KRF-V7070D	7	-	-	-	-	E7	-	-	-
KRF-V7070D-S	7	-	-	-	-	E1	-	-	-
KRF-V8070D	8	-	-	-	-	E8	-	-	-
KRF-V8070D-S	8	-	-	-	-	E2	-	-	-
KRF-X9070D	9	-	-	-	-	E9	-	-	-
KRF-X9070D-S	9	-	-	-	-	E3	-	-	-
VR-7060	8	-	P6	-	-	-	-	-	-
VR-7070	9	-	P7	-	-	-	-	-	-
VR-7080	9	-	P8	-	-	-	-	-	-
MODEL	ABB.	Mexico	PX/AAFES	Russia	Scandinavia	Shanghai	USA	Other area	
			Y				K		
KRF-V7070D	7	-	-	-	-	-	-	-	-
KRF-V7070D-S	7	-	-	-	-	-	-	-	-
KRF-V8070D	8	-	-	-	-	-	-	-	-
KRF-V8070D-S	8	-	-	-	-	-	-	-	-
KRF-X9070D	9	-	Y1	-	-	-	-	-	-
KRF-X9070D-S	9	-	-	-	-	-	-	-	-
VR-7060	8	-	-	-	-	-	K6	-	-
VR-7070	9	-	-	-	-	-	K7	-	-
VR-7080	9	-	-	-	-	-	K8	-	-

KRF-V7070D/V8070D/X9070D/VR-7060/7070/7080

SPECIFICATIONS

KRF-V7070D

AUDIO section

Rated power output during STEREO operation
DIN/IEC (63Hz ~ 12.5 kHz, 0.09 % T.H.D. at 6 Ω)
..... 100 W + 100 W

Effective power output during SURROUND operation
FRONT (63Hz ~ 12.5 kHz, 0.09 % T.H.D. at 6 Ω one channel driven)
..... 100 W + 100 W
CENTER (63Hz ~ 12.5 kHz, 0.09 % T.H.D. at 6 Ω one channel driven)
..... 100 W
SURROUND (63Hz ~ 12.5 kHz, 0.7 % T.H.D. at 6 Ω one channel driven)
..... 100 W + 100 W

Total harmonic distortion 0.009 % (1 kHz, 50 W, 6 Ω)

Frequency response
(CD/DVD, TAPE, VIDEO 1, VIDEO 2, VIDEO 3, DVD/6CH)
..... 10 Hz ~ 100 kHz, +0 dB ~ -3.0 dB

PHONO "RIAA" response 40 Hz ~ 20 kHz, +1.5 dB ~ -3.0 dB

Maximum input level
PHONO (MM) 45 mV, 1 % T.H.D. at 1 kHz

Signal to noise ratio (IHF'66)
PHONO (MM) 75 dB
(CD/DVD, TAPE, VIDEO 1, VIDEO 2, VIDEO 3, DVD/6CH)
..... 95 dB

Loudness control
VOLUME at -30 dB level +6 dB (100 Hz)

Input sensitivity / impedance
PHONO (MM) 6.0 mV / 47 kΩ
(CD/DVD, TAPE, VIDEO 1, VIDEO 2, VIDEO 3, DVD/6CH)
..... 500 mV / 47 kΩ

Output level / impedance
TAPE REC. 500 mV / 1 kΩ
PRE OUT (SURROUND BACK CHANNEL) 1 V / 1 kΩ
PRE OUT (SUBWOOFER) 1 V / 1 kΩ

Tone control
BASS ±10 dB (at 100 Hz)
TREBLE ±10 dB (at 10 kHz)

DIGITAL AUDIO section

Sampling frequency 32 kHz, 44.1 kHz, 48 kHz, 96 kHz

Input level / impedance / wave length
Optical (-15 dBm ~ -24 dBm), 660 nm ±30 nm
Coaxial 0.5 Vp-p / 75 Ω

VIDEO section

VIDEO inputs / outputs
VIDEO (composite) 1 Vp-p / 75 Ω

S VIDEO inputs / outputs
S VIDEO (luminance signal) 1 Vp-p / 75 Ω
S VIDEO (chrominance signal) 0.286 Vp-p / 75 Ω

FM tuner section

Tuning frequency range 87.5 MHz ~ 108.0 MHz

Usable sensitivity
MONO 1.3 μV (75 Ω) / 13.2 dBf (40 kHz dev, S/N 26 dB)
STEREO 45 μV (75 Ω) / 42.1 dBf (40 + 6 kHz dev, S/N 46 dB)

Total harmonic distortion
MONO (1 kHz, 40 kHz dev) 0.2% (65.2 dBf input)
STEREO (1 kHz, 40 + 6 kHz dev) 0.8% (65.2 dBf input)

Signal to noise ratio (DIN weighted at 1 kHz)
MONO 65 dB (65.2 dBf input)
STEREO 60 dB (65.2 dBf input)

Stereo separation (1 kHz) 36 dB

Selectivity (DIN ±300 kHz) 64 dB

Frequency response (30 Hz ~ 15 kHz) +0.5 dB, -3.0 dB

AM tuner section

Tuning frequency range 531 kHz ~ 1,602 kHz

Usable sensitivity (30% mod, S/N 20 dB) 16 μV / (600 μV/m)

Signal to noise ratio (30% mod, 400 Hz) 50 dB (60 dBμV EMF input)

GENERAL

Power consumption 330 W

AC outlet
SWITCHED (total 90 W max.)

Dimensions W : 440 mm (17-5/16")
H : 159 mm (6-1/4")
D : 392 mm (15-7/16")

Weight (Net) 9.8 kg (20.6 lb)

KRF-V8070D

AUDIO section

Rated power output during STEREO operation
DIN/IEC (63Hz ~ 12.5 kHz, 0.09 % T.H.D. at 6 Ω)
..... 100 W + 100 W

Effective power output during SURROUND operation
FRONT (63Hz ~ 12.5 kHz, 0.09 % T.H.D. at 6 Ω one channel driven)
..... 100 W + 100 W
CENTER (63Hz ~ 12.5 kHz, 0.09 % T.H.D. at 6 Ω one channel driven)
..... 100 W
SURROUND (63Hz ~ 12.5 kHz, 0.7 % T.H.D. at 6 Ω one channel driven)
..... 100 W + 100 W
SURROUND BACK/SUBWOOFER (63Hz ~ 12.5 kHz, 0.09 % T.H.D. at 6 Ω one channel driven) 100W

Total harmonic distortion 0.009 % (1 kHz, 50 W, 6 Ω)

Frequency response
(CD/DVD, TAPE, VIDEO 1, VIDEO 2, VIDEO 3, DVD/6CH)
..... 10 Hz ~ 100 kHz, +0 dB ~ -3.0 dB

PHONO "RIAA" response 40 Hz ~ 20 kHz, +1.5 dB ~ -3.0 dB

Maximum input level
PHONO (MM) 45 mV, 1 % T.H.D. at 1 kHz

Signal to noise ratio (IHF'66)
PHONO (MM) 75 dB
(CD/DVD, TAPE, VIDEO 1, VIDEO 2, VIDEO 3, DVD/6CH)
..... 95 dB

Loudness control
VOLUME at -30 dB level +6 dB (100 Hz)

Input sensitivity / impedance
PHONO (MM) 6.0 mV / 47 kΩ
(CD/DVD, TAPE, VIDEO 1, VIDEO 2, VIDEO 3, DVD/6CH)
..... 500 mV / 47 kΩ

Output level / impedance
TAPE REC. 500 mV / 1 kΩ
PRE OUT (SURROUND BACK CHANNEL) 1 V / 1 kΩ
PRE OUT (SUBWOOFER) 1 V / 1 kΩ

Tone control
BASS ±10 dB (at 100 Hz)
TREBLE ±10 dB (at 10 kHz)

DIGITAL AUDIO section

Sampling frequency 32 kHz, 44.1 kHz, 48 kHz, 96 kHz

Input level / impedance / wave length
Optical (-15 dBm ~ -24 dBm), 660 nm ±30 nm
Coaxial 0.5 Vp-p / 75 Ω

VIDEO section

VIDEO inputs / outputs
VIDEO (composite) 1 Vp-p / 75 Ω

S VIDEO inputs / outputs
S VIDEO (luminance signal) 1 Vp-p / 75 Ω
S VIDEO (chrominance signal) 0.286 Vp-p / 75 Ω

COMPONENT VIDEO inputs / outputs
COMPONENT VIDEO (luminance signal) 1 Vp-p / 75 Ω
COMPONENT VIDEO (CB/CR-signal) ±0.32 Vp-p / 75 Ω

FM tuner section

Tuning frequency range 87.5 MHz ~ 108.0 MHz

Usable sensitivity
MONO 1.3 μV (75 Ω) / 13.2 dBf (40 kHz dev, S/N 26 dB)
STEREO 45 μV (75 Ω) / 42.1 dBf (40 + 6 kHz dev, S/N 46 dB)

Total harmonic distortion
MONO (1 kHz, 40 kHz dev) 0.2% (65.2 dBf input)
STEREO (1 kHz, 40 + 6 kHz dev) 0.8% (65.2 dBf input)

Signal to noise ratio (DIN weighted at 1 kHz)
MONO 65 dB (65.2 dBf input)
STEREO 60 dB (65.2 dBf input)

Stereo separation (1 kHz) 36 dB

Selectivity (DIN ±300 kHz) 64 dB

Frequency response (30 Hz ~ 15 kHz) +0.5 dB, -3.0 dB

AM tuner section

Tuning frequency range 531 kHz ~ 1,602 kHz

Usable sensitivity (30% mod, S/N 20 dB) 16 μV / (600 μV/m)

Signal to noise ratio (30% mod, 400 Hz) 50 dB (60 dBμV EMF input)

GENERAL

Power consumption 330 W

AC outlet
SWITCHED (total 90 W max.)

Dimensions W : 440 mm (17-5/16")
H : 159 mm (6-1/4")
D : 392 mm (15-7/16")

Weight (Net) 9.8 kg (20.6 lb)

Notes

1. KENWOOD follows a policy of continuous advancements in development. For this reason specifications may be changed without notice.
2. The full performance may not be exhibited in an extremely cold location (under a water-freezing temperature).

KRF-V7070D/V8070D/X9070D/VR-7060/7070/7080

SPECIFICATIONS

VR-7070

AUDIO section

Rated power output during STEREO operation

100 watts per channel minimum RMS, both channels driven, at 8 Ω from 20 Hz to 20 kHz with no more than 0.09% total harmonic distortion. (FTC)

Effective power output during SURROUND operation

FRONT (20 ~ 20 kHz, 0.09 % T.H.D. at 8 Ω one channel driven)	100 W + 100 W
CENTER (20 ~ 20 kHz, 0.09 % T.H.D. at 8 Ω one channel driven)	100 W
SURROUND (20 ~ 20 kHz, 0.7 % T.H.D. at 8 Ω one channel driven)	100 W + 100 W
SURROUND BACK/SUBWOOFER (20 ~ 20 kHz, 0.09 % T.H.D. at 8 Ω one channel driven)	100 W
Total harmonic distortion	0.009 % (1 kHz, 50 W, 8 Ω)
Frequency response	(CD/DVD, TAPE, VIDEO 1, VIDEO 2, VIDEO 3, DVD/6CH)
	10 Hz ~ 100 kHz, +0 dB ~ -3.0 dB
PHONO 'RIAA' response	40 Hz ~ 20 kHz, +1.5 dB ~ -3.0 dB
Maximum input level	PHONO (MM) 45 mV, 1 % T.H.D. at 1 kHz
Signal to noise ratio (IHF'66)	PHONO (MM) 75 dB
	(CD/DVD, TAPE, VIDEO 1, VIDEO 2, VIDEO 3, DVD/6CH)
	95 dB
Loudness control	VOLUME at -30 dB level +6 dB (100 Hz)
Input sensitivity / impedance	PHONO (MM) 4.0 mV / 47 k Ω
	(CD/DVD, TAPE, VIDEO 1, VIDEO 2, VIDEO 3, DVD/6CH)
	320 mV / 47 k Ω
Output level / impedance	TAPE REC..... 320 mV / 1 k Ω
	PRE OUT (FRONT, CENTER, SURROUND) 1 V / 500 Ω
	PRE OUT (SURROUND BACK CHANNEL) 1 V / 500 Ω
	PRE OUT (SUBWOOFER) 1 V / 500 Ω
Tone control	BASS ± 10 dB (at 100 Hz)
	TREBLE ± 10 dB (at 10 kHz)

DIGITAL AUDIO section

Sampling frequency	32 kHz, 44.1 kHz, 48 kHz, 96 kHz
Input level / impedance / wave length	Optical (-15 dBm ~ -24 dBm), 660 nm ± 30 nm
	Coaxial 0.5 Vp-p / 75 Ω
Output level / impedance / wave length	Optical (-21 dBm ~ -15 dBm), 660 nm ± 30 nm

Notes

1. KENWOOD follows a policy of continuous advancements in development. For this reason specifications may be changed without notice.
2. The full performance may not be exhibited in an extremely cold location (under a water-freezing temperature).

VIDEO section

VIDEO inputs / outputs	VIDEO (composite) 1 Vp-p / 75 Ω
S VIDEO inputs / outputs	S VIDEO (luminance signal) 1 Vp-p / 75 Ω
	S VIDEO (chrominance signal) 0.286 Vp-p / 75 Ω
COMPONENT VIDEO inputs / outputs	COMPONENT VIDEO (luminance signal) 1 Vp-p / 75 Ω
	COMPONENT VIDEO (CB/CR-signal) ± 0.32 Vp-p / 75 Ω

FM tuner section

Tuning frequency range	87.5 MHz ~ 108.0 MHz
Usable sensitivity (MONO)	1.3 μ V (75 Ω) / 13.2 dBf (75 kHz dev, SINAD 30 dB)
50 dB quieting sensitivity	STEREO 28 μ V (75 Ω) / 40.2 dBf
Total harmonic distortion	MONO (1 kHz, 75 kHz dev) 0.5% (65 dBf input)
	STEREO (1 kHz, 67.5 + 6.75 kHz dev) 0.7% (65 dBf input)
Signal to noise ratio	MONO (1 kHz, 75 kHz dev) 75 dB (65 dBf input)
	STEREO (1 kHz, 67.5 + 6.75 kHz dev) 68 dB (65 dBf input)
Stereo separation (1 kHz)	40 dB
Selectivity (± 400 kHz)	70 dB
Frequency response (30 Hz ~ 15 kHz)	+0.5 dB, -3.0 dB

AM tuner section

Tuning frequency range	10 kHz step 530 kHz ~ 1,700 kHz
Usable sensitivity (30% mod, S/N 20 dB)	16 μ V / (600 μ V/m)
Signal to noise ratio (30% mod, 400 Hz)	50 dB (60 dB μ V EMF input)

GENERAL

Power consumption	3 A
AC outlet	SWITCHED (total 150 W, 1.25 A max.)
Dimensions	W : 440 mm (17-5/16")
	H : 159 mm (6-1/4")
	D : 392 mm (15-7/16")
Weight (Net)	9.4 kg (20.7 lb)

KENWOOD CORPORATION

2967-3, Ishikawa-machi, Hachioji-shi, Tokyo, 192-8525 Japan

KENWOOD U.S.A. CORPORATION

P.O. BOX 22745, 2201 East Dominguez St., Long Beach, CA 90801-5745, U.S.A.

KENWOOD ELECTRONICS CANADA INC.

6070 Kestrel Road, Mississauga, Ontario, Canada L5T 1S8

KENWOOD ELECTRONICS LATIN AMERICA S.A.

P.O. BOX 55-2791, Piso 6 plaza Chase, Cl. 47 y Aquilino de la Guardia Panama, Republic of Panama

KENWOOD ELECTRONICS BRASIL LTDA.

Alameda Ministro Rocha Azevedo No. 456, Edifício Jaú, 10o Andar, Cerqueira César, Cep 0140-001, São Paulo-SP-Brasil

KENWOOD ELECTRONICS U.K. LIMITED

KENWOOD House, Dwight Road, Watford, Herts., WD18 9EB, United Kingdom

KENWOOD ELECTRONICS BELGIUM N.V.

Leuvensesteenweg 248 J, 1800 Vilvoorde, Belgium

KENWOOD ELECTRONICS DEUTSCHLAND GMBH

Rembrücker Str. 15, 63150 Heusenstamm, Germany

KENWOOD ELECTRONICS FRANCE S.A.

13 Boulevard Ney, 75018 Paris, France

KENWOOD ELECTRONICS ITALIA S.p.A.

Via G. Sirtori, 7/9 20129, Milano, Italy

KENWOOD IBÉRICA S.A.

Bolivia, 239-08020 Barcelona, Spain

KENWOOD ELECTRONICS AUSTRALIA PTY. LTD.

(A.C.N. 001 499 074)
16 Giffnock Avenue, North Ryde, N.S.W. 2113, Australia

KENWOOD ELECTRONICS (HONG KONG) LTD.

Unit 3712-3724, Level 37, Tower 1, Metroplaza, 223 Hing Fong Road, Kwai Fong N.T., Hong Kong

KENWOOD ELECTRONICS GULF FZE

P.O. Box 61318, Jebel Ali, Dubai, U.A.E.

KENWOOD ELECTRONICS SINGAPORE PTE LTD.

No. 1 Genting Lane #02-02, KENWOOD Building, Singapore, 349544

KENWOOD ELECTRONICS (MALAYSIA) SDN BHD.

#4.01 Level 4, Wisma Academy Lot 4A, Jalan 19/1 46300 Petaling Jaya Selangor Darul Ehsan Malaysia

KENWOOD ELECTRONICS (THAILAND) CO., LTD.

2019 New Pechburi Road, Bangkapi, Huaykwang, Bangkok, 10320 Thailand