

KRF-V4080D/V4080D-S/V5080D/V5080D-S
 KRF-V5580D-S/V6080D/V6080D-S
 VR-804-S/806/806-S
SERVICE MANUAL

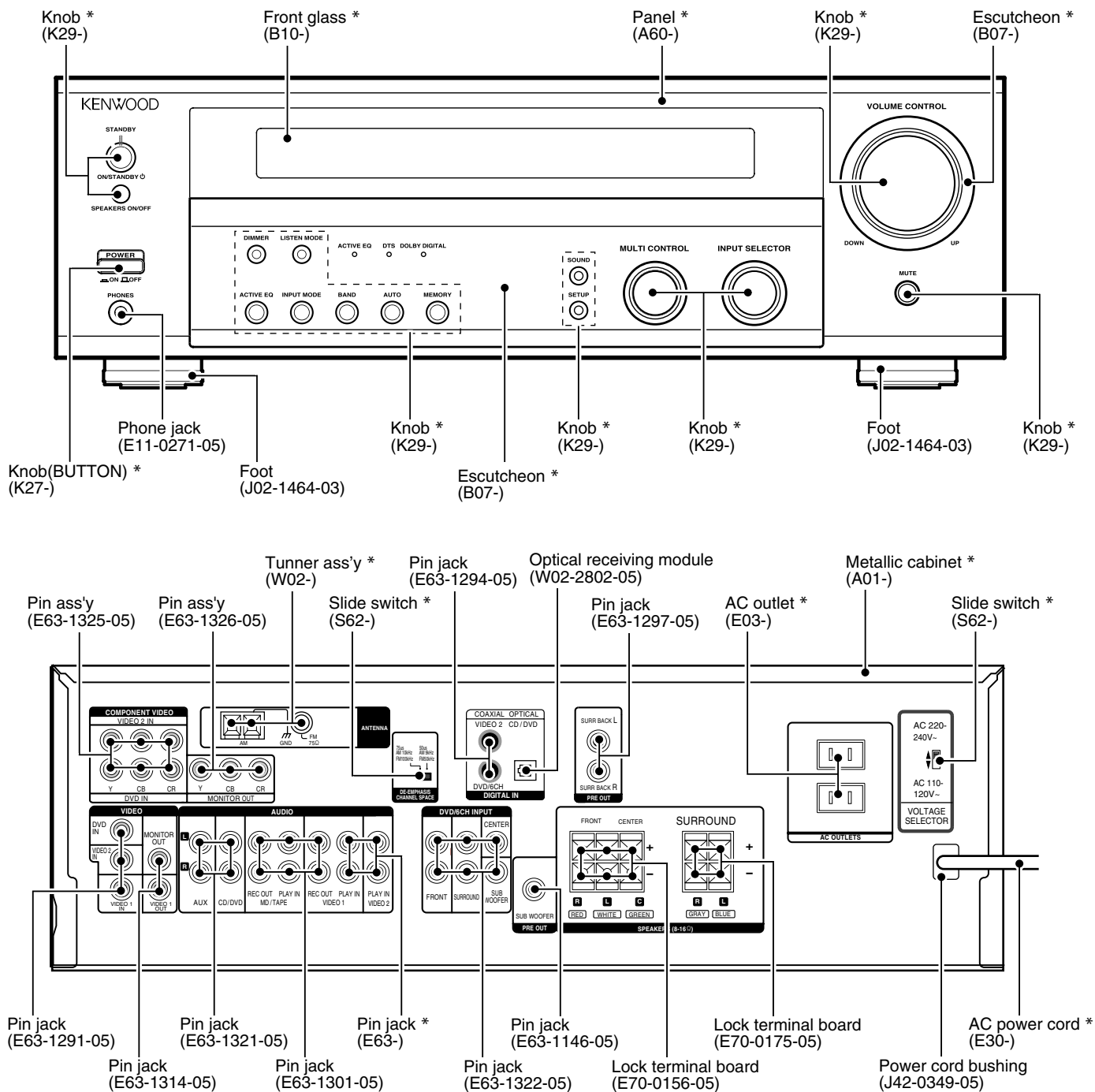

Illust. is KRF-V5080D.



* Refer to parts list on page 29.



KRF-V4080D/V5080D/V5580D-S/V6080D/VR-804-S/806

ACCESSORIES / CAUTIONS

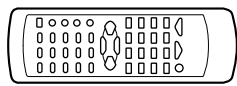
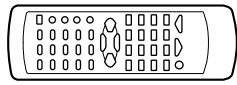
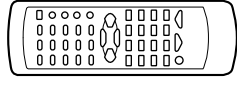
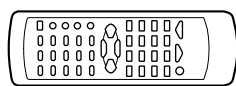
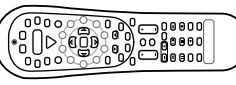
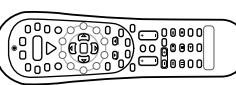
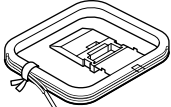
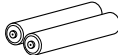
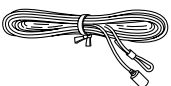
Accessories

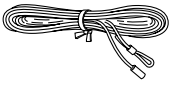
<p>Remote control unit (1) (See the below table)</p> <p>RC-R0625</p>  <p>RC-R0626</p>  <p>RC-R0627</p> 	<p>RC-R0628</p>  <p>RC-R0824</p>  <p>RC-R0825</p> 	<p>AM loop antenna (1) (T90-0893-05)</p> 	<p>Batteries (R6/AA) (2)</p> 
		<p>FM indoor antenna (1) U.S.A. and Canada (T90-0905-05)</p>  <p>Other countries (T90-0877-05)</p> 	<p>AC plug adapter (1) (E03-0508-00)</p>  <p>Use to adapt the plug on the power cord to the shape of the wall outlet. (Accessory only for regions where use is necessary.)</p>

REMOTE CONTROL vs MODEL

MODEL	PARTS #	REMOTE CONTROL #	DESTINATION	MODEL	PARTS #	REMOTE CONTROL #	DESTINATION
KRF-V4080D	A70-1613-05	RC-R0627	E6	KRF-V5580D-S	A70-1612-05	RC-R0626	X3Y3
KRF-V4080D-S			E7	KRF-V6080D	A70-1618-05	RC-R0825	E1
KRF-V4080D	A70-1611-05	RC-R0625	X7	KRF-V6080D-S			E2
KRF-V5080D	A70-1613-05	RC-R0627	E4	KRF-V6080D	A70-1617-05	RC-R0824	Y1
KRF-V5080D-S			E5	KRF-V6080D-S			X2Y2
KRF-V5080D	A70-1611-05	RC-R0825	Y4	VR-804-S	A70-1612-05	RC-R0626	K3P3
KRF-V5080D-S			X5Y5	VR-806	A70-1612-05	RC-R0626	K1P1
KRF-V5580D-S	A70-1614-05	RC-R0628	E3	VR-806-S			K2P2

Cautions

Resetting the Microcomputer

The microcomputer may malfunction (unit cannot be operated, or shows an erroneous display) if the power cord is unplugged while the power is ON, or due to some other external factor. If this happens, execute the following procedure to reset the microcomputer and return the unit to its normal operating condition.

- Please note that resetting the microcomputer will clear the contents of the memory and return the unit to the state it was in when it left the factory.

For the U.S.A. and Canada

Unplug the power cord from the wall outlet, then plug it back in while holding down the **POWER ON/STANDBY** key.

For other countries

With the power cord plugged in, turn the **POWER ON/OFF** key OFF. Then, while holding down the **ON/STANDBY** key, press **POWER ON/OFF** key.

Memory back up function

Please note that the following items will be deleted from the unit's memory if the power cord is disconnected from the AC outlet for approximately 1 day.

- | | | | |
|--|---|---|---|
| <ul style="list-style-type: none"> Power mode Input selector settings Picture output Speaker ON/OFF Volume level BASS, TREBLE, INPUT level TONE ON/OFF LOUDNESS ON/OFF Dimmer level | <ul style="list-style-type: none"> MD/TAPE settings Listen mode setting SP SYSTEM Speaker settings Distance setting SUBWOOFER ON/OFF SW RE-MIX ON/OFF Input mode setting Midnight mode setting | <ul style="list-style-type: none"> Broadcast band Frequency setting Preset stations Tuning mode ACTIVE EQ mode PRO LOGIC II mode DSP mode Left channel level Right channel level | <ul style="list-style-type: none"> Center channel level Surround channel level Surround Back channel level Subwoofer level PANORAMA ON / OFF DIMENSION CENTER WIDTH LFE level |
|--|---|---|---|

KRF-V4080D/V5080D/V5580D-S/V6080D/MR-804-S/806

INTERCONNECTION DIAGRAM

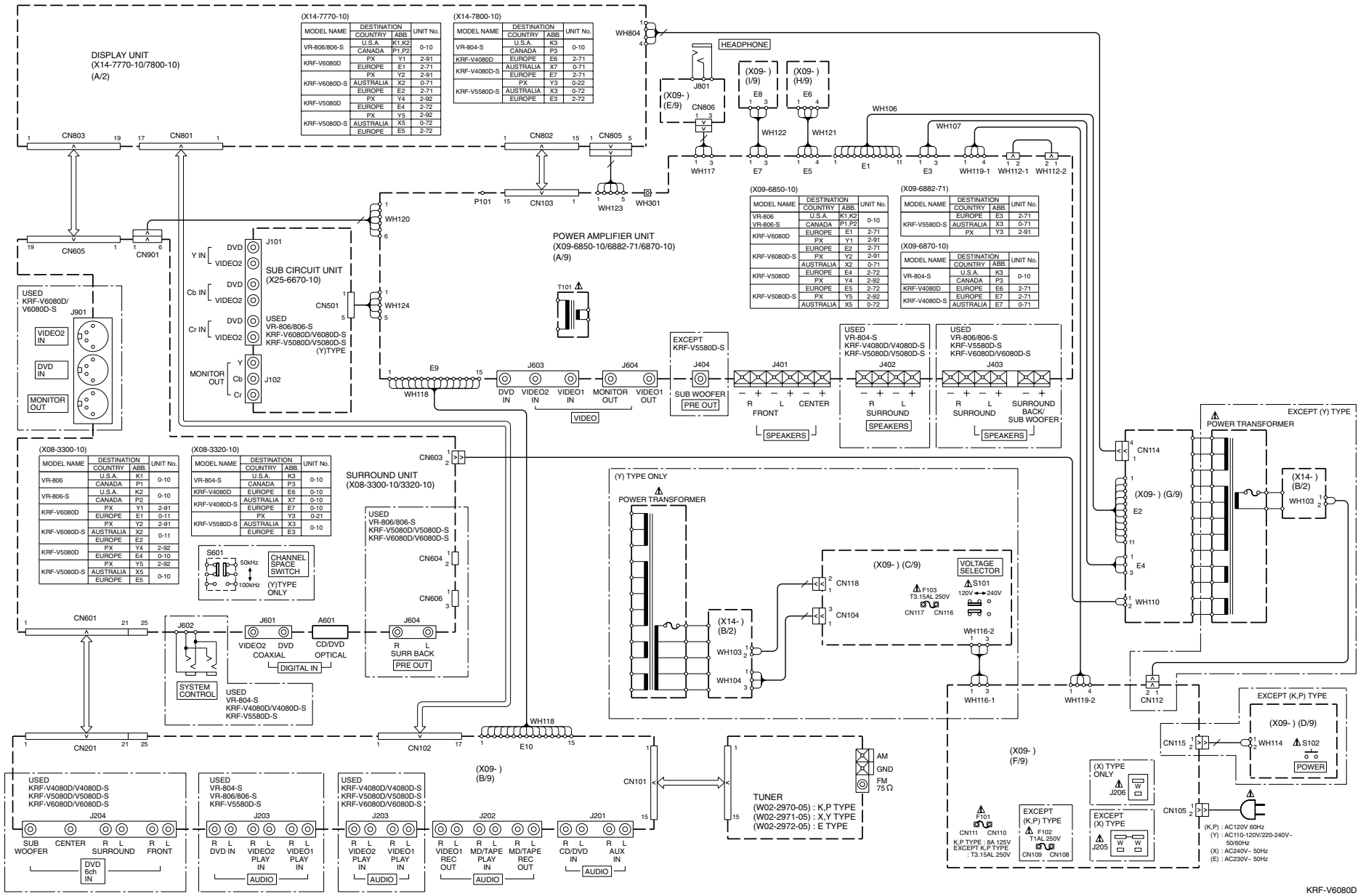

KRF-V6080D

PC BOARD(Component side view)

X08-3300-10 (J70-1714-12) (SIDE A)

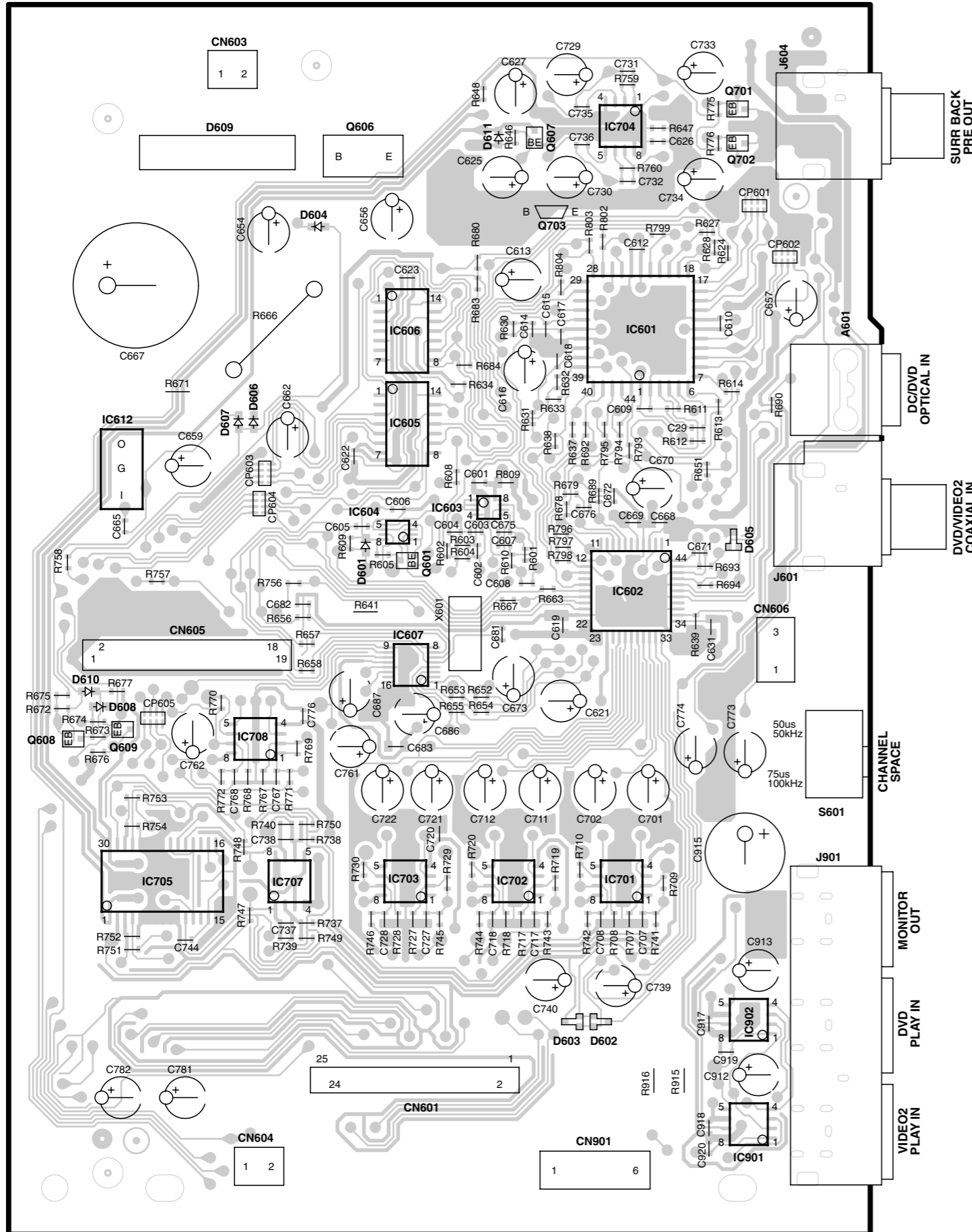

X08-3300-10 (J70-1714-12) (SIDE B)

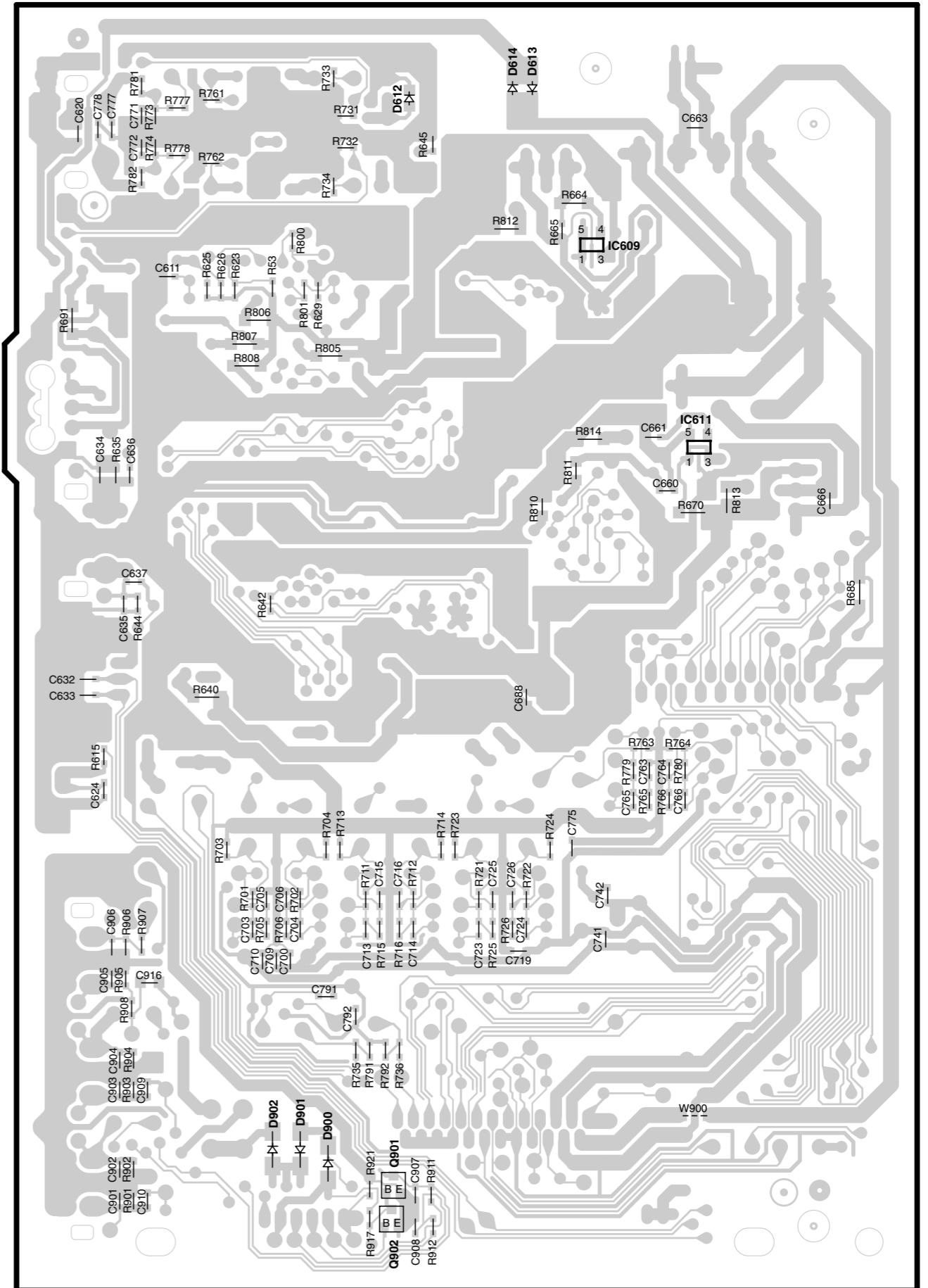

Refer to the schematic diagram for the value of resistors and capacitors.

PC BOARD(Component side view)

X08-3320-10 (J70-1716-02) (SIDE A)

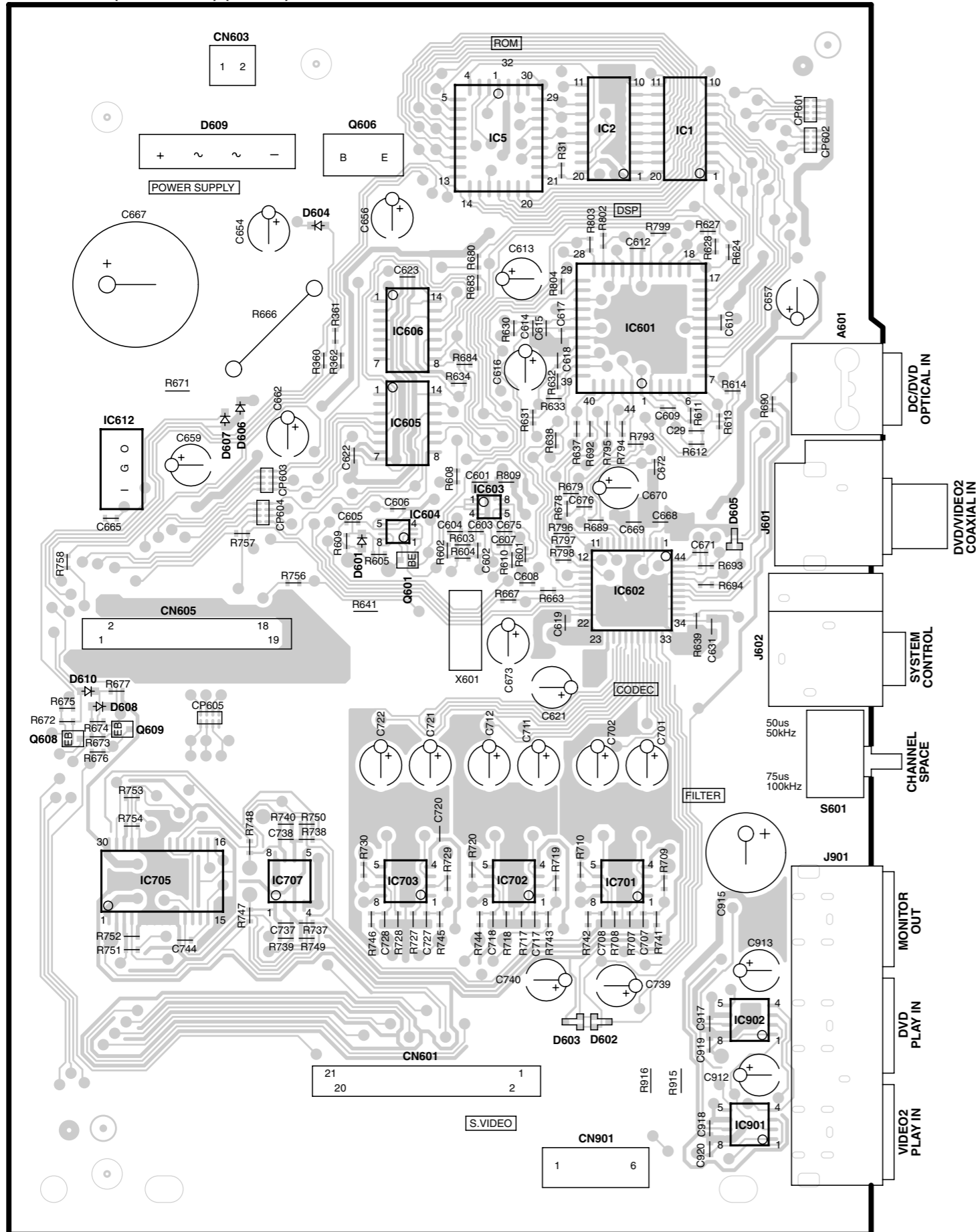

X08-3320-10 (J70-1716-02) (SIDE B)

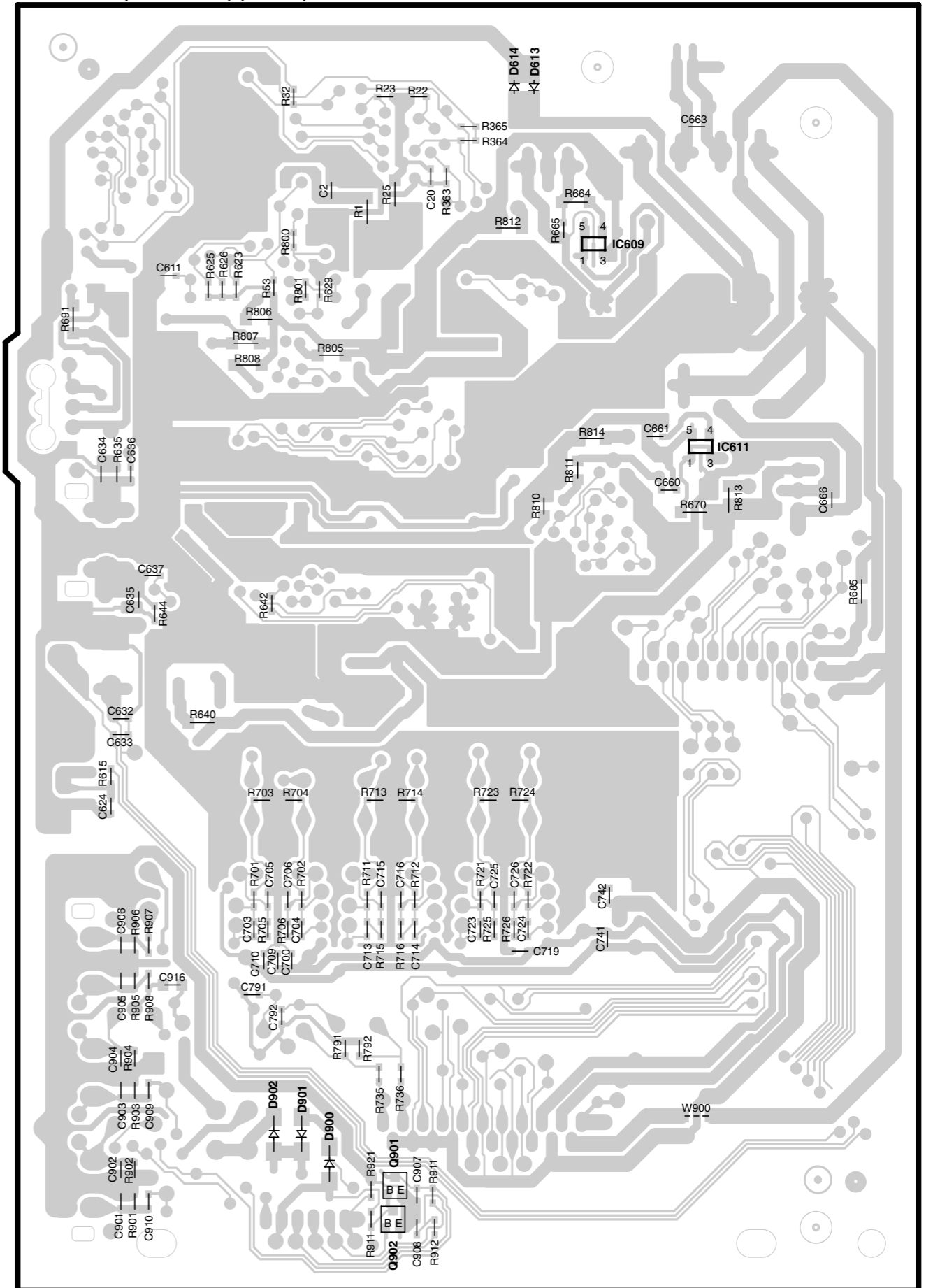

Refer to the schematic diagram for the value of resistors and capacitors.

PC BOARD(Component side view)

X09-6870-10 A/9 (J70-1717-01)
X09-6880-10 A/9 (J70-1718-01)

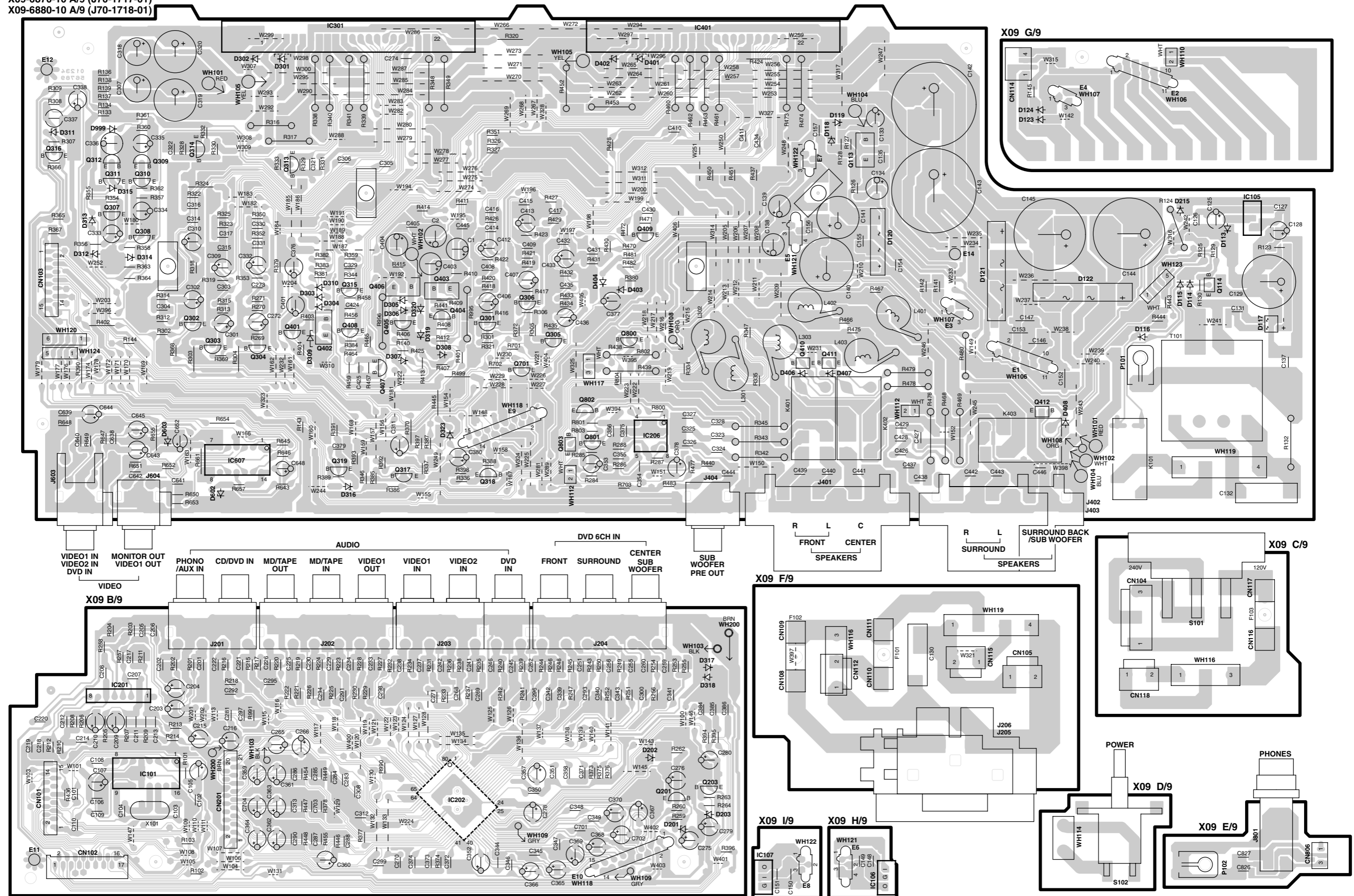

Refer to the schematic diagram for the value of resistors and capacitors.

PC BOARD(Component side view)

X14-7770-10 A/2 (J70-1713-11)
X14-7800-10 A/2 (J70-1719-01)

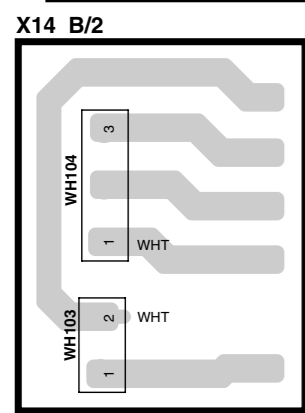
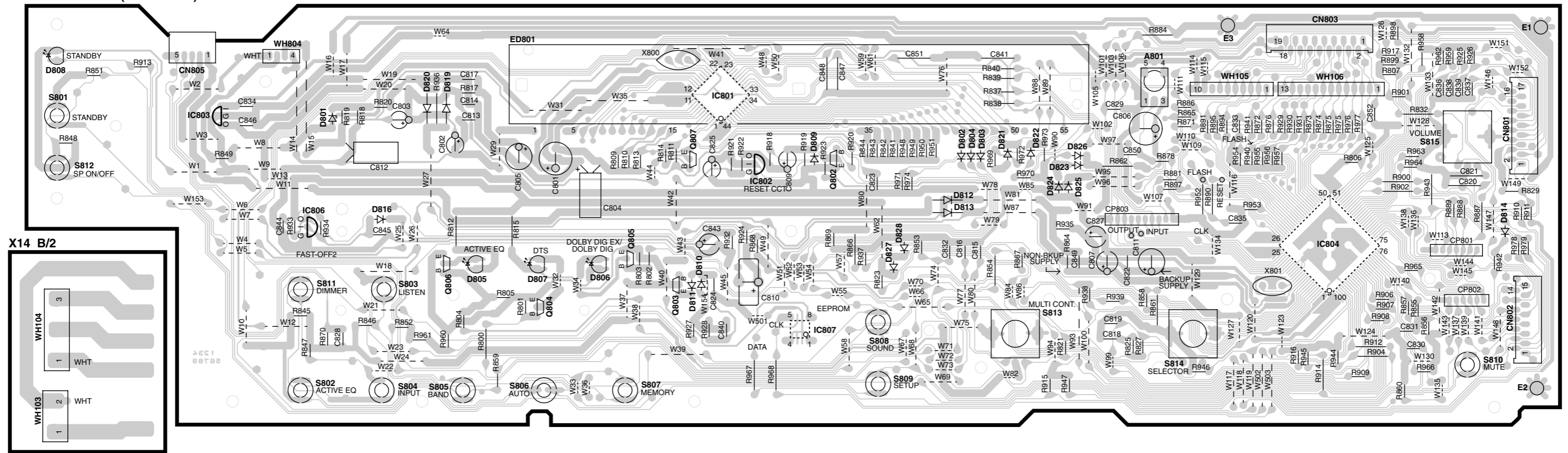

PC BOARD (Component side view)

X25-6670-10 (J70-1720-02)

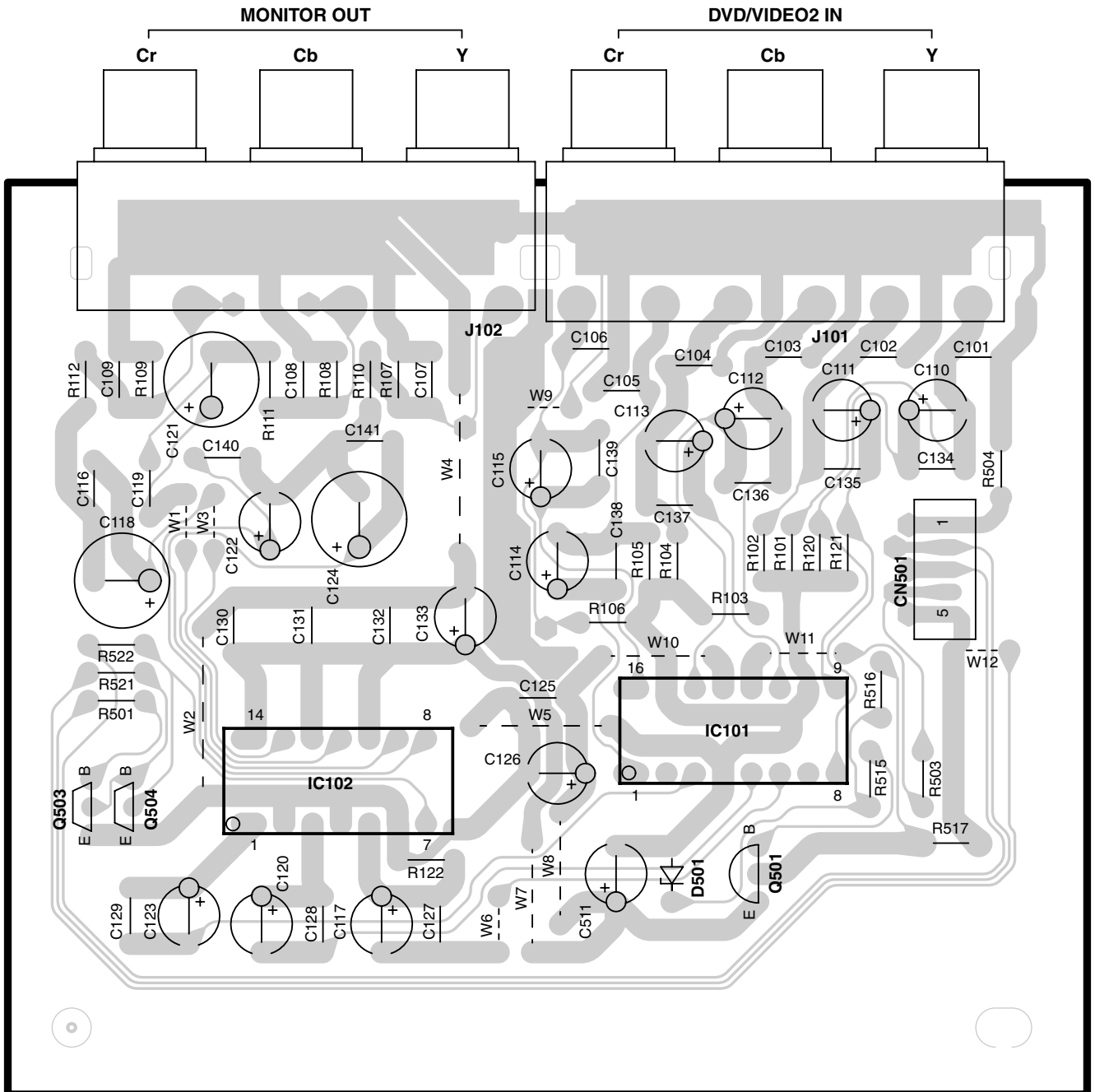

KRF-V4080D/V5080D/V5580D/V6080D/VR-804-S/806

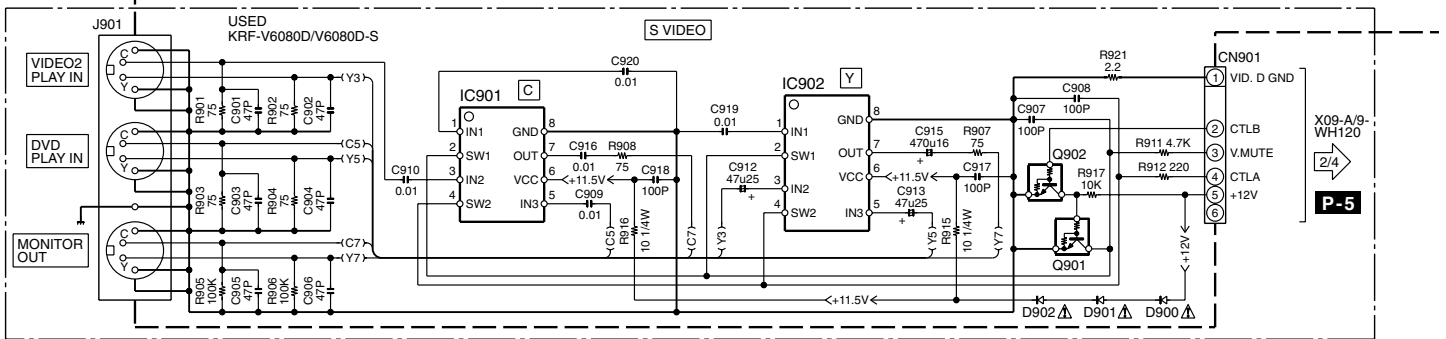
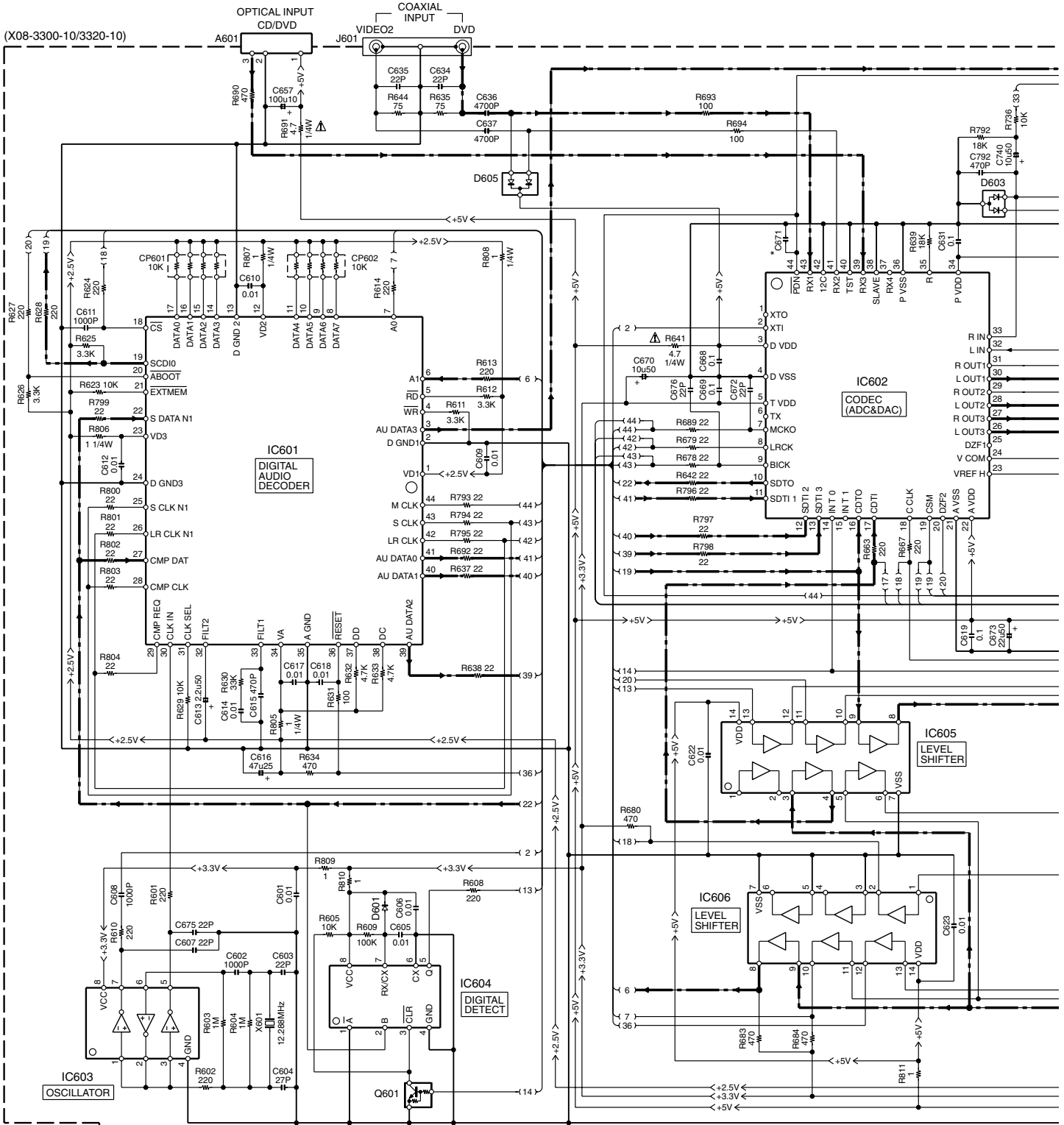

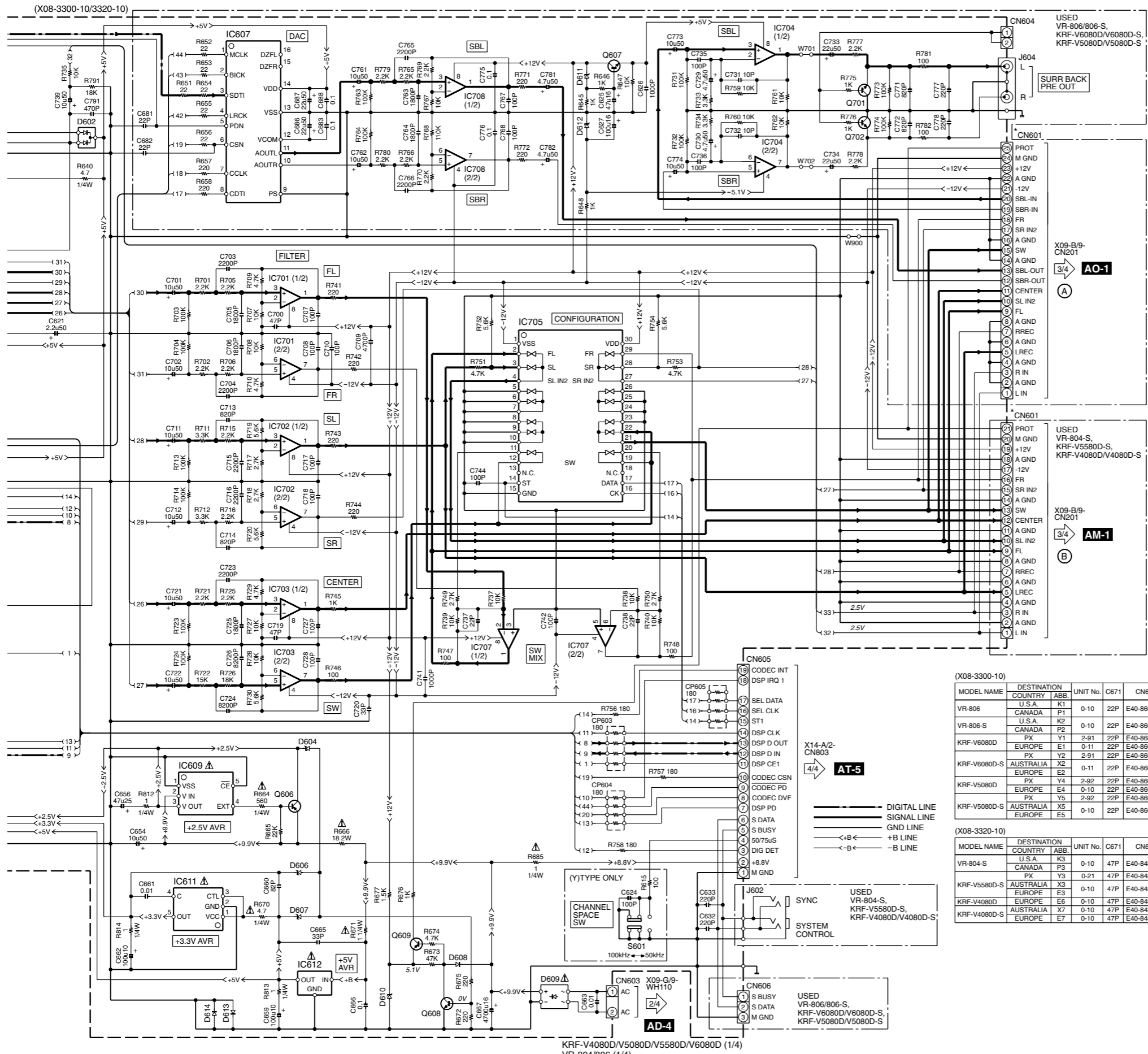

- USED
VR-806/806-S,
KRF-V6080D/V6080D-S,
KRF-V5080D/V5080D-S
- IC601 : CS493263-CLG or CS493263-CLR
 - IC602 : AK4586
 - IC603 : TC7WU04FU
 - IC604 : TC7WH123FU
 - IC605 : TC74HCT7007AF
 - IC606 : TC74HC07AF
 - IC607 : AK4384
 - IC609 : XC62EP2502MR
 - IC611 : BA033LBSG
 - IC612 : BA05T
 - IC701-704,707,708 : NJM4565MD
 - IC705 : NJU7311AM
 - IC901,902 : MM128XF
- Q601,901,902 : DTC124EUA or UN5212
- Q606 : 2SB1375
- Q607 : 2SC4081(R,S)
- Q608 : 2SD1819A(Q,R) or 2SC4081(R,S)
- Q609 : 2SA1576A(R,S) or 2SB1218A(Q,R)
- D601,608,613,614 : MA111
- D602,605 : 1SS301 or DAN202U or MA142WK
- D603 : 1SS300 or DAP202U or MA142WA
- D604 : UDZS3.9B or HZU3.9(B2)
- D606,607 : UDZS5.6B or HZU5.6(B2)
- D609 : D2SBA20F03
- D610,612 : UDZS5.1B or HZU5.1(B2)
- D611 : UDZS6.2B or HZU6.2(B2)
- D900-902 : 1SR154-400

(X08-3300-10)

MODEL NAME	DESTINATION COUNTRY	ABB.	UNIT No.	C671	CN601
VR-806	U.S.A.	K1	0-10	22P	E40-8601-05
	CANADA	P1	0-10	22P	E40-8601-05
VR-806-S	U.S.A.	K2	0-10	22P	E40-8601-05
	CANADA	P2	0-10	22P	E40-8601-05
KRF-V6080D	PX	Y1	2-91	22P	E40-8601-05
	EUROPE	E1	0-11	22P	E40-8601-05
KRF-V6080D-S	PX	Y2	2-91	22P	E40-8601-05
	AUSTRALIA	X2	0-11	22P	E40-8601-05
KRF-V5080D	EUROPE	E2	0-11	22P	E40-8601-05
	PX	Y4	2-92	22P	E40-8601-05
KRF-V5080D-S	EUROPE	E4	0-10	22P	E40-8601-05
	PX	Y5	2-92	22P	E40-8601-05
KRF-V5080D-S	AUSTRALIA	X5	0-10	22P	E40-8601-05
	EUROPE	E5	0-10	22P	E40-8601-05

(X08-3320-10)

MODEL NAME	DESTINATION COUNTRY	ABB.	UNIT No.	C671	CN601
VR-804-S	U.S.A.	K3	0-10	47P	E40-8484-05
	CANADA	P3	0-10	47P	E40-8484-05
KRF-V5580D-S	AUSTRALIA	X3	0-21	47P	E40-8484-05
	EUROPE	E3	0-10	47P	E40-8484-05
KRF-V4080D	EUROPE	E6	0-10	47P	E40-8484-05
	AUSTRALIA	X7	0-10	47P	E40-8484-05
KRF-V4080D-S	AUSTRALIA	X7	0-10	47P	E40-8484-05
	EUROPE	E7	0-10	47P	E40-8484-05

CAUTION: For continued safety, replace safety critical components only with manufacturer's recommended parts (refer to parts list). Δ indicates safety critical components. For continued protection against risk of fire, replace only with same type and rating fuse(s). To reduce the risk of electric shock, leakage-current or resistance measurements shall be carried out (exposed parts are acceptably insulated from the supply circuit) before the appliance is returned to the customer.

The DC voltage is an actual reading measured with a high impedance type voltmeter with no signal input. The measurement value may vary depending on the measuring instruments used or on the product.

KRF-V4080D/V5080D/V5580D/V6080D (1/4)
VR-804/806 (1/4)

KRF-V4080D/V5080D/V5580D-S/V6080D/VR-804-S/806

(X09-6850-10/6870-10/6882-71) (A/9)

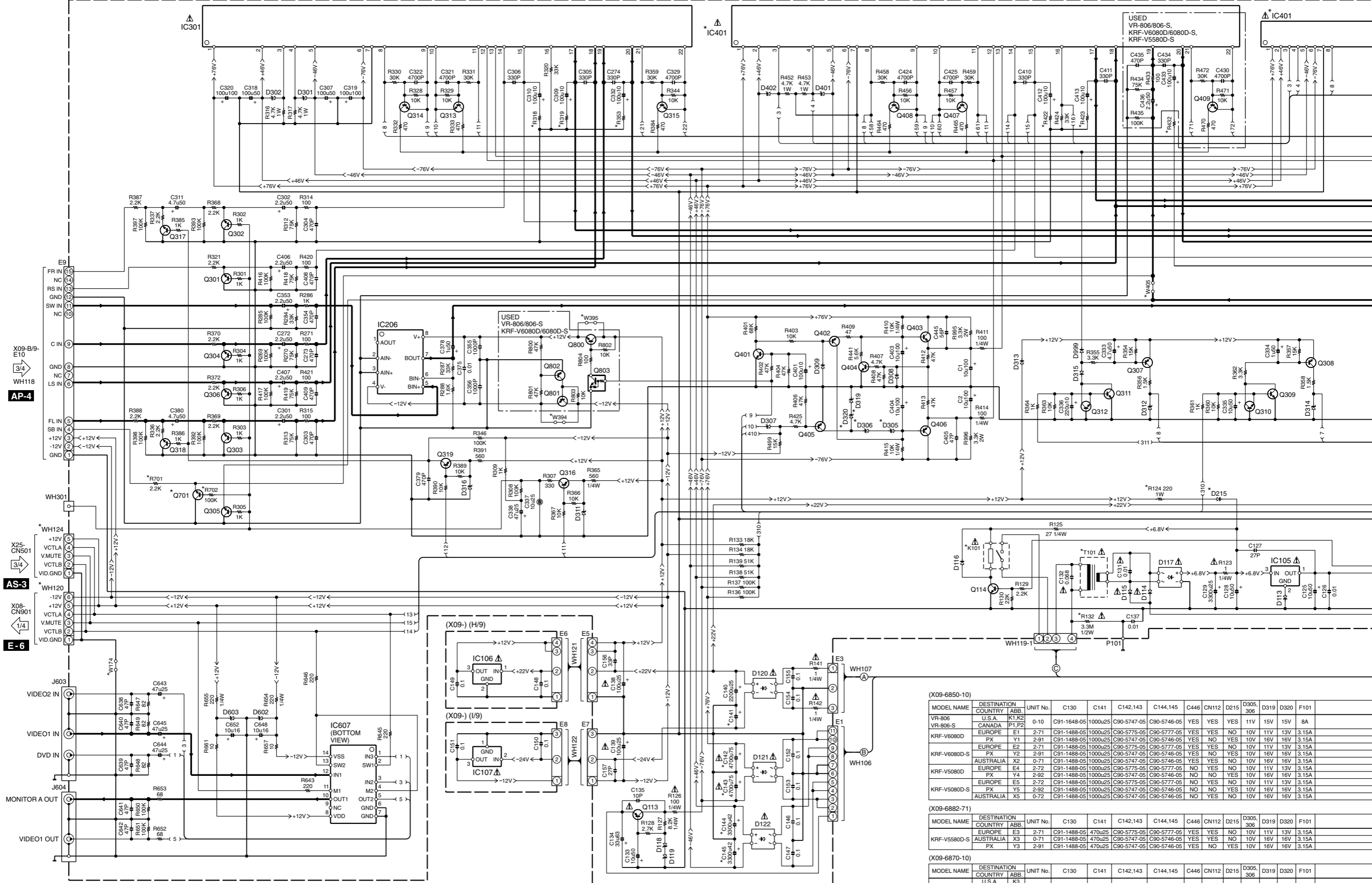

(X09-6850-10)

MODEL NAME	DESTINATION COUNTRY	ABB.	UNIT No.	C130	C141	C142,143	C144,145	C446	CN112	D215	D305, 306	D319	D320	F101
VR-806	U.S.A.	K1,K2	0-10	C91-1648-05	1000u25	C90-5747-05	C90-5746-05	YES	YES	YES	11V	15V	15V	8A
VR-806-S	CANADA	P1,P2						NO	YES	NO	10V	11V	13V	3.15A
KRF-V6080D	EUROPE	E1	2-71	C91-1488-05	1000u25	C90-5747-05	C90-5746-05	YES	NO	NO	10V	11V	13V	3.15A
	PX	Y1	2-91	C91-1488-05	1000u25	C90-5747-05	C90-5746-05	YES	NO	NO	10V	11V	13V	3.15A
KRF-V6080D-S	EUROPE	E2	2-71	C91-1488-05	1000u25	C90-5747-05	C90-5746-05	YES	NO	NO	10V	11V	13V	3.15A
	PX	Y2	2-91	C91-1488-05	1000u25	C90-5747-05	C90-5746-05	YES	NO	NO	10V	11V	13V	3.15A
KRF-V5080D	AUSTRALIA	X2	0-71	C91-1488-05	1000u25	C90-5747-05	C90-5746-05	YES	YES	NO	10V	16V	16V	3.15A
	EUROPE	E4	2-72	C91-1488-05	1000u25	C90-5747-05	C90-5746-05	NO	NO	NO	10V	11V	13V	3.15A
KRF-V5080D-S	EUROPE	E5	2-72	C91-1488-05	1000u25	C90-5747-05	C90-5746-05	NO	NO	NO	10V	11V	13V	3.15A
	PX	Y5	2-92	C91-1488-05	1000u25	C90-5747-05	C90-5746-05	NO	NO	YES	10V	16V	16V	3.15A
	AUSTRALIA	X5	0-72	C91-1488-05	1000u25	C90-5747-05	C90-5746-05	NO	YES	NO	10V	16V	16V	3.15A

(X09-6882-71)

MODEL NAME	DESTINATION COUNTRY	ABB.	UNIT No.	C130	C141	C142,143	C144,145	C446	CN112	D215	D305, 306	D319	D320	F101
KRF-V5580D-S	EUROPE	E3	2-71	C91-1488-05	470u25	C90-5747-05	C90-5747-05	YES	YES	NO	10V	11V	13V	3.15A
	AUSTRALIA	X3	0-71	C91-1488-05	470u25	C90-5747-05	C90-5746-05	YES	NO	NO	10V	16V	16V	3.15A
	PX	Y3	2-91	C91-1488-05	470u25	C90-5747-05	C90-5746-05	YES	NO	YES	10V	16V	16V	3.15A

(X09-6870-10)

MODEL NAME	DESTINATION COUNTRY	ABB.	UNIT No.	C130	C141	C142,143	C144,145	C446	CN112	D215	D305, 306	D319	D320	F101
VR-804-S	U.S.A.	K3	0-10	C91-1648-05	470u25	C90-5747-05	C90-5746-05	NO	YES	YES	11V	15V	15V	8A
	CANADA	P3						NO	YES	NO	10V	11V	13V	3.15A
KRF-V4080D	EUROPE	E6	2-71	C91-1488-05	470u25	C90-5747-05	C90-5747-05	NO	YES	NO	10V	11V	13V	3.15A
KRF-V4080D-S	EUROPE	E7	2-71	C91-1488-05	470u25	C90-5747-05	C90-5746-05	NO	YES	NO	10V	11V	13V	3.15A
	AUSTRALIA	X7	0-71	C91-1488-05	470u25	C90-5747-05	C90-5746-05	NO	YES	NO	10V	16V	16V	3.15A

(X09-6850-10/6870-10/6882-71) (A/9)

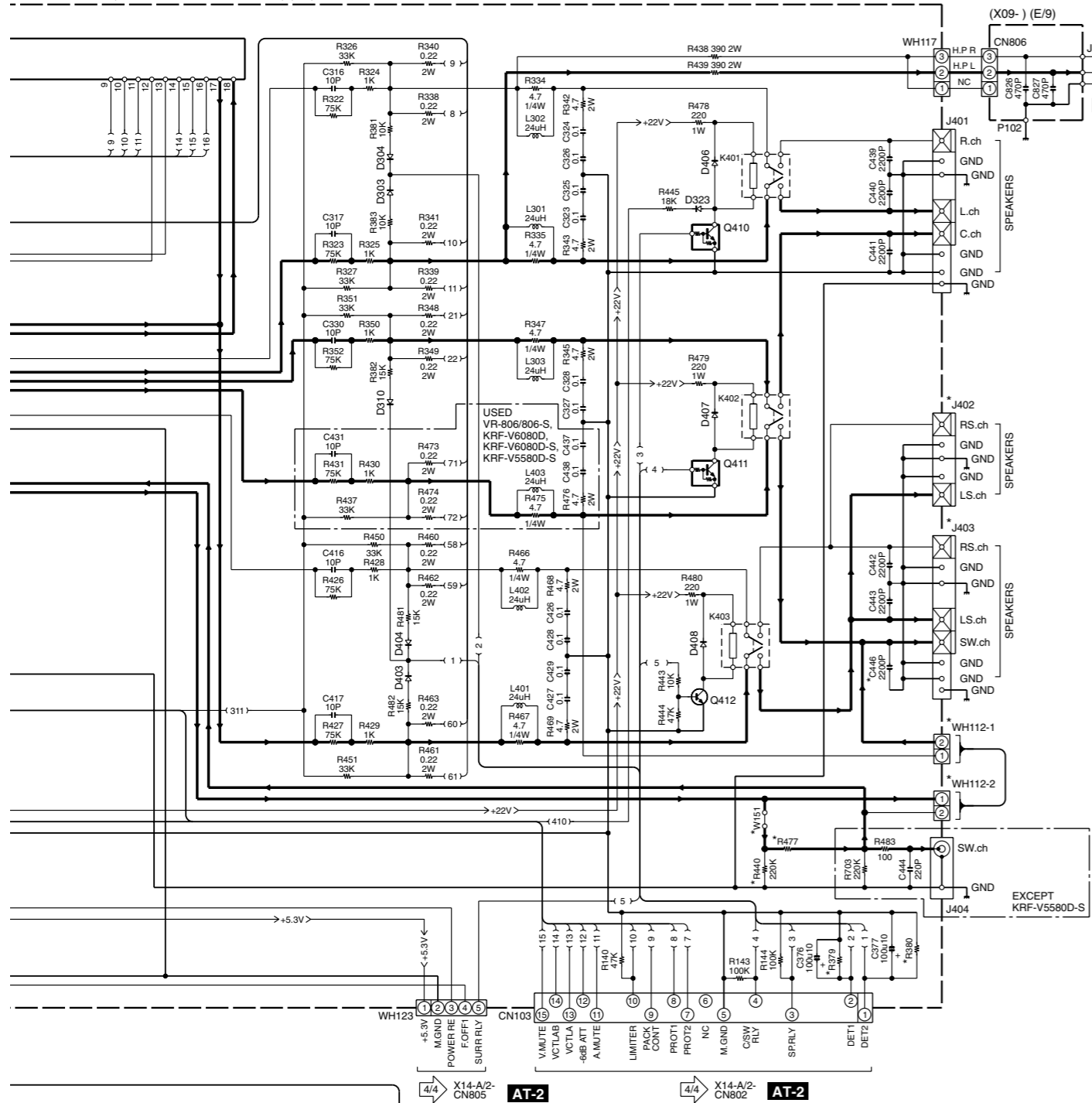

- IC105 : BA05T
- IC106 : KIA7812API
- IC107 : KIA7912PI
- IC206 : NJM4565D
- IC301 : STK-413-220A
- IC401 : *
- IC607 : NJM2279D
- Q113,406 : 2SB1640
- Q114,412 : 2SC1740(Q,R) or 2SC2785S(F,E)
- Q301-306,317,318,701 : 2SC2878(B)
- Q307,308,316,319,405,801,802 : 2SA992(F,E)
- Q309-315,401,404,407-409,800 : 2SC1845(F,E)
- Q402 : 2SA1535A
- Q403 : 2SC3944A
- Q410,411,803 : UN4219 or DTC113ZSA
- D113 : RB441Q-40
- D114-116,123,124,215,303,304,308-310,313,315,323,403,404,406-408 : 1SS133 or HSS104A
- D117 : S1ZB20(4101)
- D118 : MTZJ16(B) or HZS16N(B2)
- D119,301,302,401,402 : MTZJ15(B) or HZS15N(B2)
- D120 : D2SBA20F03
- D121,122 : D5SBA20F03
- D305,306 : D307,311,312,314,316 : MTZJ3.9(B) or HZS3.9N(B2)
- D319 : *
- D320 : *
- D602,603 : MTZJ5.6(B) or HZS5.6N(B2)

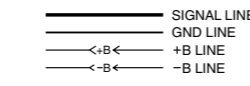

CAUTION: For continued safety, replace safety critical components only with manufacturer's recommended parts (refer to parts list). Δ indicates safety critical components. For continued protection against risk of fire, replace only with same type and rating fuse(s). To reduce the risk of electric shock, leakage-current or resistance measurements shall be carried out (exposed parts are acceptably insulated from the supply circuit) before the appliance is returned to the customer.

The DC voltage is an actual reading measured with a high impedance type voltmeter with no signal input. The measurement value may vary depending on the measuring instruments used or on the product.

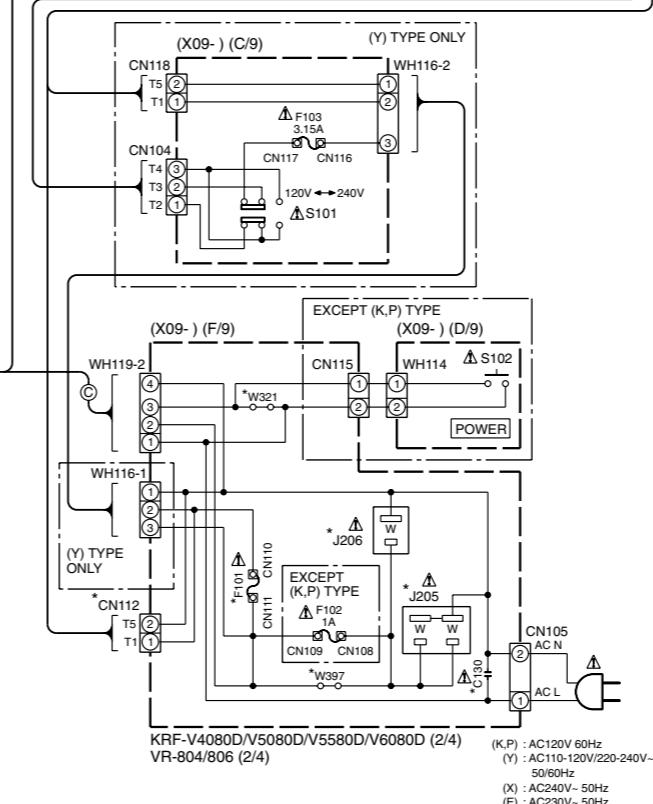
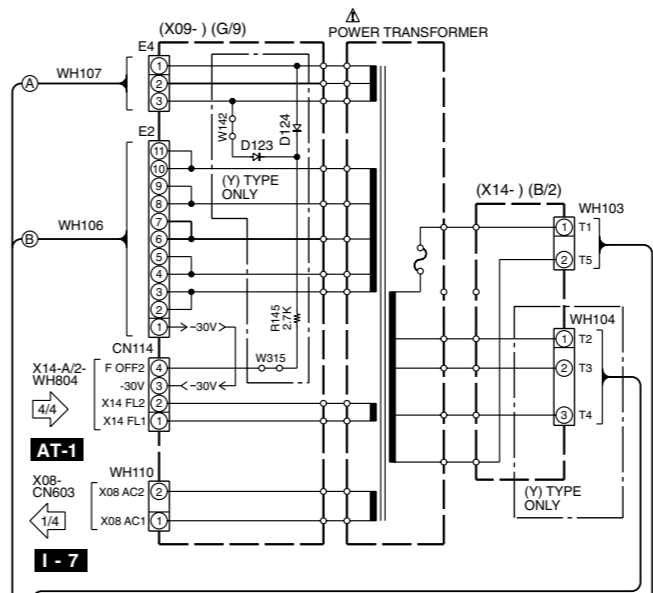

IC401	J205	J206	J402	J403	K101	Q701	R124	R132	R318,319,353,422,423	R379,380	R432	R440	R477	R701,702	T101	W151	W174	W321,397	W394,395	W405	WH112	WH120	WH124	
STK-413-220A	E03-0396-05	NO	NO	YES	S76-0099-05	YES	YES	YES	680	1.2K	680	YES	1K	YES	L07-2758-05	YES	YES	YES	NO	NO	NO	NO	YES	YES
STK-413-220A	E03-0396-05	NO	NO	YES	S76-0102-05	YES	NO	NO	820	1.5K	820	YES	1K	YES	L07-2758-05	YES	YES	NO	NO	NO	NO	YES	YES	YES
STK-413-220A	E03-0396-05	NO	NO	YES	S76-0102-05	YES	YES	NO	680	1.2K	680	YES	1K	YES	L07-2805-05	YES	YES	NO	NO	NO	NO	YES	YES	YES
STK-413-220A	E03-0396-05	NO	NO	YES	S76-0102-05	YES	NO	NO	820	1.5K	820	YES	1K	YES	L07-2758-05	YES	YES	NO	NO	NO	NO	YES	YES	YES
STK-413-220A	E03-0396-05	NO	NO	YES	S76-0102-05	YES	YES	YES	680	1.2K	680	YES	1K	YES	L07-2805-05	YES	YES	NO	NO	NO	NO	YES	YES	YES
STK-413-220A	E03-0396-05	NO	NO	YES	S76-0102-05	YES	NO	NO	680	1.2K	680	YES	1K	YES	L07-2758-05	YES	YES	NO	NO	NO	NO	YES	YES	YES
STK-413-220A	E03-0396-05	NO	NO	YES	S76-0102-05	YES	NO	NO	820	1.5K	820	NO	NO	YES	L07-2758-05	NO	NO	NO	NO	NO	NO	YES	YES	YES
STK-413-220A	E03-0396-05	NO	NO	YES	S76-0102-05	YES	NO	NO	680	1.2K	680	NO	NO	YES	L07-2805-05	NO	NO	NO	NO	NO	NO	YES	YES	YES
STK-413-220A	E03-0396-05	NO	NO	YES	S76-0102-05	YES	NO	NO	820	1.5K	820	NO	NO	YES	L07-2758-05	NO	NO	NO	NO	NO	NO	YES	YES	YES
STK-413-220A	E03-0396-05	NO	NO	YES	S76-0102-05	YES	NO	NO	680	1.2K	680	NO	NO	YES	L07-2805-05	NO	NO	NO	NO	NO	NO	YES	YES	YES
STK-413-220A	E03-0396-05	NO	NO	YES	S76-0102-05	YES	NO	NO	680	1.2K	680	NO	NO	YES	L07-2758-05	NO	NO	NO	NO	NO	NO	YES	YES	YES

IC401	J205	J206	J402	J403	K101	Q701	R124	R132	R318,319,353,422,423	R379,380	R432	R440	R477	R701,702	T101	W151,394,395,405	W174,321,397	W394,395	WH112	WH120	WH124		
STK-413-220A	E03-0396-05	NO	NO	YES	S76-0102-05	NO	NO	NO	820	1.5K	3K	YES	2.2K	NO	L07-2758-05	YES	NO	NO	NO	NO	NO	NO	NO
STK-413-220A	E03-0396-05	NO	NO	YES	S76-0102-05	NO	NO	NO	680	1.2K	2.4K	YES	2.2K	NO	L07-2758-05	YES	NO	NO	NO	NO	NO	NO	NO
STK-413-220A	E03-0396-05	NO	NO	YES	S76-0102-05	NO	YES	NO	680	1.2K	2.4K	YES	2.2K	NO	L07-2805-05	YES	NO	NO	NO	NO	NO	NO	NO

IC401	J205	J206	J402	J403	K101	Q701	R124	R132	R318,319,353,422,423	R379,380	R432,440,477,701,702	T101	W151,174,405	W321,397	W394,395	WH112	WH120	WH124				
STK-412-220A	E03-0396-05	NO	YES	NO	S76-0099-05	NO	YES	NO	680	1.2K	NO	NO	L07-2758-05	NO	YES	YES	YES	NO	NO	NO	NO	NO
STK-412-220A	E03-0396-05	NO	YES	NO	S76-0102-05	NO	NO	NO	820	1.5K	NO	NO	L07-2758-05	NO	NO	YES	YES	NO	NO	NO	NO	NO
STK-412-220A	E03-0396-05	NO	YES	NO	S76-0102-05	NO	NO	NO	820	1.5K	NO	NO	L07-2758-05	NO	NO	YES	YES	NO	NO	NO	NO	NO
STK-412-220A	E03-0396-05	NO	YES	NO	S76-0102-05	NO	NO	NO	680	1.2K	NO	NO	L07-2758-05	NO	NO	YES	YES	NO	NO	NO	NO	NO

KRF-V4080D/V5080D/V5580D-S/V6080D/VR-804-S/806

MODEL NAME		DESTINATION COUNTRY	UNIT No.	A	C245, 246	C300, 339-343	C391,392, 701-703	J203	R239, 240	R247, 248	R251,252, 255,256	R377	R990, 991	W201, 202
VR-804-S		U.S.A.	K3	0-10	NO	YES	NO	E63-1301-05	YES	47K	47K	47K	220K	YES
KRF-V4080D		EUROPE	E6	2-71	YES	NO	NO	E63-1321-05	NO	15K	22K	47K	100K	NO
KRF-V4080D-S		EUROPE	E7	2-71	YES	NO	NO	E63-1321-05	NO	15K	22K	47K	100K	NO
KRF-V4080D-S		AUSTRALIA	X7	0-71	NO	NO	NO	E63-1321-05	NO	15K	22K	47K	220K	YES

MODEL NAME		DESTINATION COUNTRY	UNIT No.	A	C245, 246	C300, 339-343, 391,392,701-703	J203	R239, 240	R247,248,251, 252,255,256	R377	R990, 991	W201, 202
VR-806-S		EUROPE	E3	2-71	NO	NO	E63-1301-05	YES	47K	47K	220K	YES
KRF-V5580D-S		AUSTRALIA	X3	0-71	NO	NO	E63-1301-05	YES	47K	47K	220K	YES
KRF-V5580D-S		AUSTRALIA	Y3	2-91	NO	NO	E63-1301-05	YES	47K	47K	220K	YES

MODEL NAME		DESTINATION COUNTRY	UNIT No.	A	C245, 246	C300, 339-343	C391,392, 701,703	C702	J203	R239, 240	R247, 248	R251,252, 255,256	R377	R990, 991	W201, 202	
VR-806		U.S.A.	K1,K2	0-10	NO	YES	NO	YES	YES	E63-1301-05	YES	47K	47K	100K	220K	YES
VR-806-S		CANADA	P1,P2	2-71	YES	NO	YES	YES	YES	E63-1321-05	NO	15K	22K	100K	100K	NO
KRF-V6080D		EUROPE	E1	2-71	YES	NO	NO	YES	YES	E63-1321-05	NO	15K	22K	100K	100K	NO
KRF-V6080D-S		EUROPE	E2	2-71	YES	NO	NO	YES	YES	E63-1321-05	NO	15K	22K	100K	100K	NO
KRF-V6080D-S		PX	Y2	2-91	NO	NO	NO	YES	YES	E63-1321-05	NO	15K	22K	100K	220K	YES
KRF-V6080D-S		AUSTRALIA	X2	0-71	NO	NO	NO	YES	YES	E63-1321-05	NO	15K	22K	100K	220K	YES
KRF-V6080D-S		EUROPE	E4	2-72	YES	NO	NO	YES	YES	E63-1321-05	NO	15K	22K	100K	100K	NO
KRF-V6080D-S		PX	Y4	2-92	NO	NO	NO	YES	YES	E63-1321-05	NO	15K	22K	100K	220K	YES
KRF-V6080D-S		EUROPE	E5	2-72	YES	NO	NO	YES	YES	E63-1321-05	NO	15K	22K	100K	100K	NO
KRF-V6080D-S		PX	Y5	2-92	NO	NO	NO	YES	YES	E63-1321-05	NO	15K	22K	100K	220K	YES
KRF-V6080D-S		AUSTRALIA	X5	0-72	NO	NO	NO	YES	YES	E63-1321-05	NO	15K	22K	100K	220K	YES

--- DIGITAL LINE
 - - - RECORDING LINE
 _____ SIGNAL LINE
 _____ GND LINE
 <-+B< +B LINE
 <-B< -B LINE

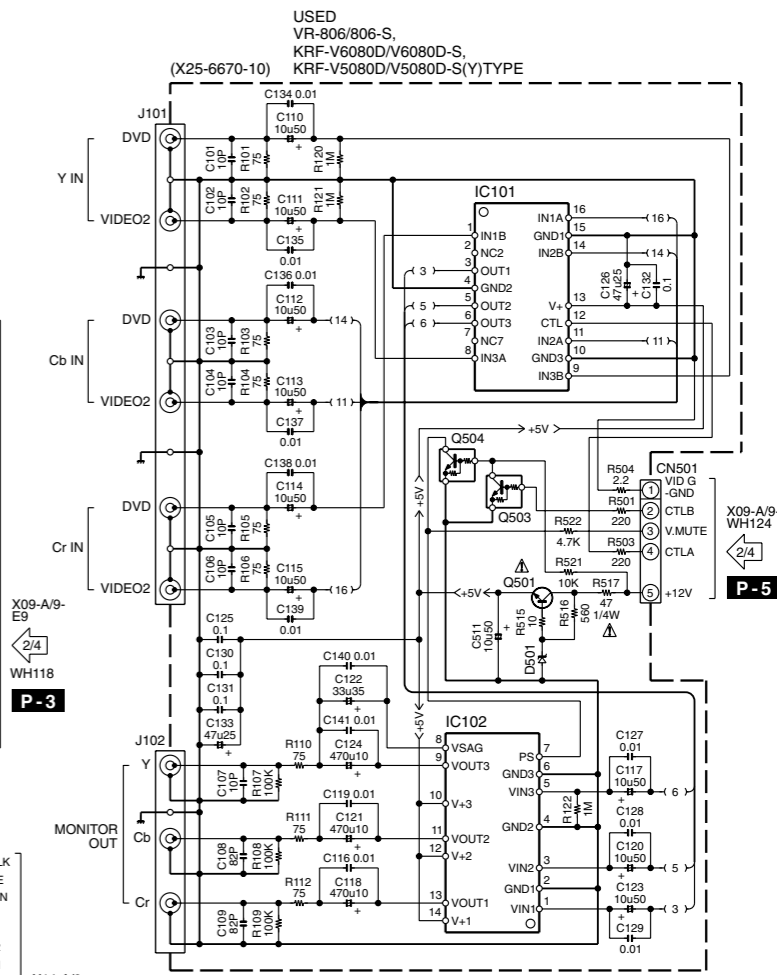
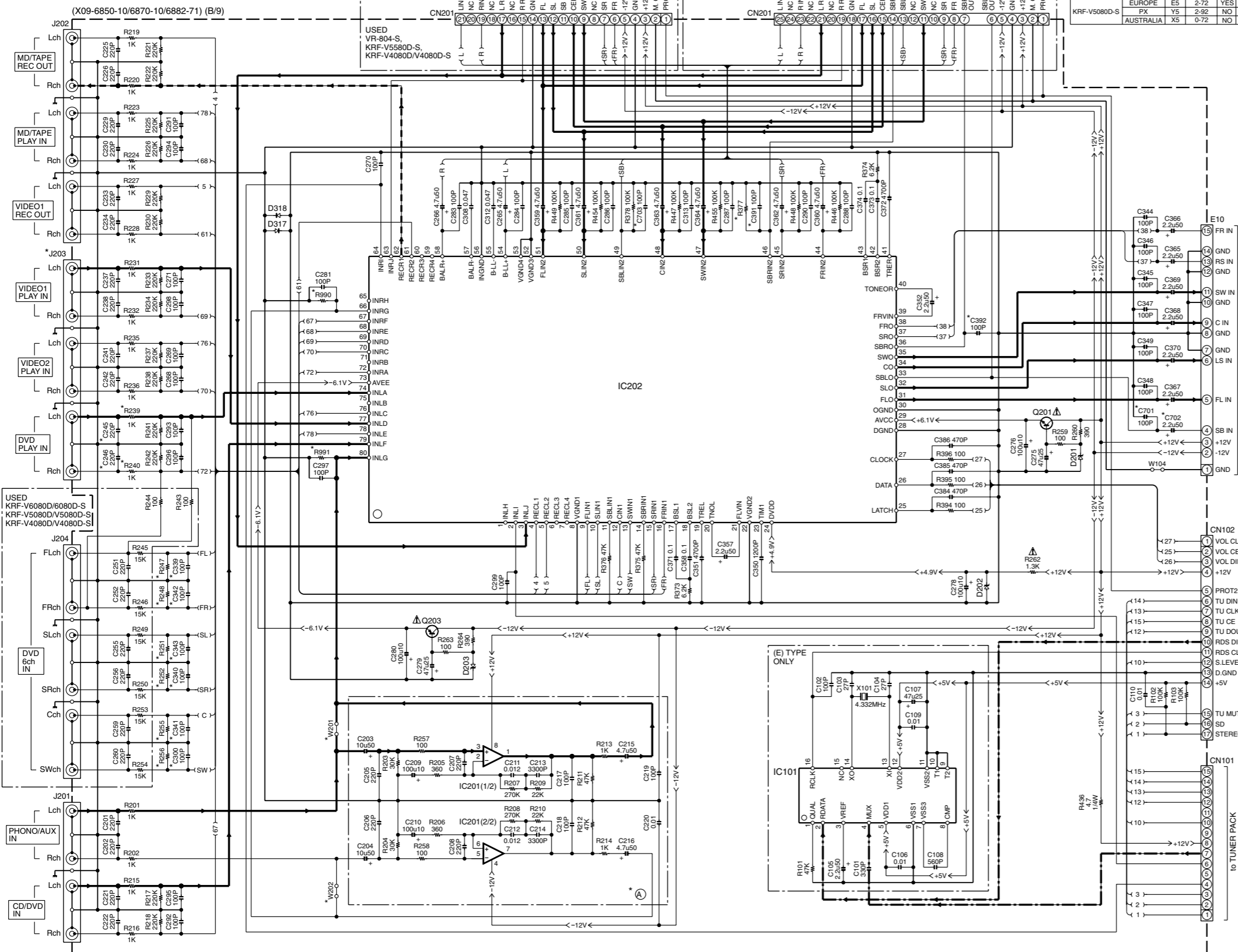

- (X25-6670-10)
 USED VR-806/806-S, KRF-V6080D/V6080D-S, KRF-V5080D/V5080D-S(Y)TYPE
- (X25-)
 IC101 : NJM2584D
 IC102 : NJM2580D
 Q501 : 2SC3940A(R,S)
 Q503,504 : UN4212 or DTC124ESA
 D501 : MTZJ5.6(B) or HZS5.6N(B2)
- (X09-)
 IC101 : BU1923 D201,203 : MTZJ6.8(B) or HZS6.8N(B2)
 IC201 : NJM4580L-D D202 : MTZJ5.1(B) or HZS5.1N(B2)
 IC202 : M61516FP D202 : MTZJ5.1(B) or HZS5.1N(B2)
 Q201 : 2SC1845(FE) D317,318 : 1SS133 or HSS104A
 Q203 : 2SA992(FE)

CAUTION: For continued safety, replace safety critical components only with manufacturer's recommended parts (refer to parts list). Δ indicates safety critical components. For continued protection against risk of fire, replace only with same type and rating fuse(s). To reduce the risk of electric shock, leakage-current or resistance measurements shall be carried out (exposed parts are acceptably insulated from the supply circuit) before the appliance is returned to the customer.

The DC voltage is an actual reading measured with a high impedance type voltmeter with no signal input. The measurement value may vary depending on the measuring instruments used or on the product.

KRF-V4080D/V5080D/V5580D/V6080D (3/4)
 VR-804/806 (3/4)

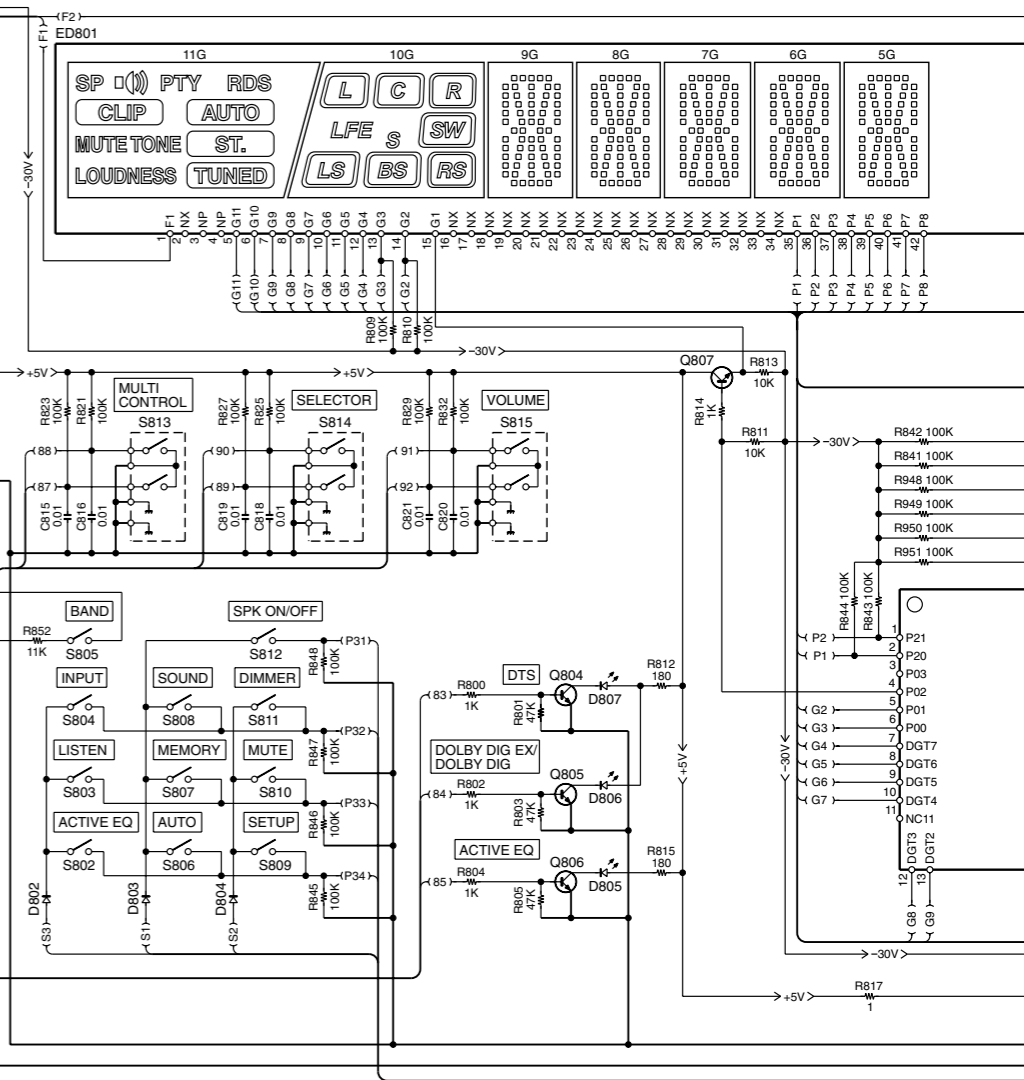
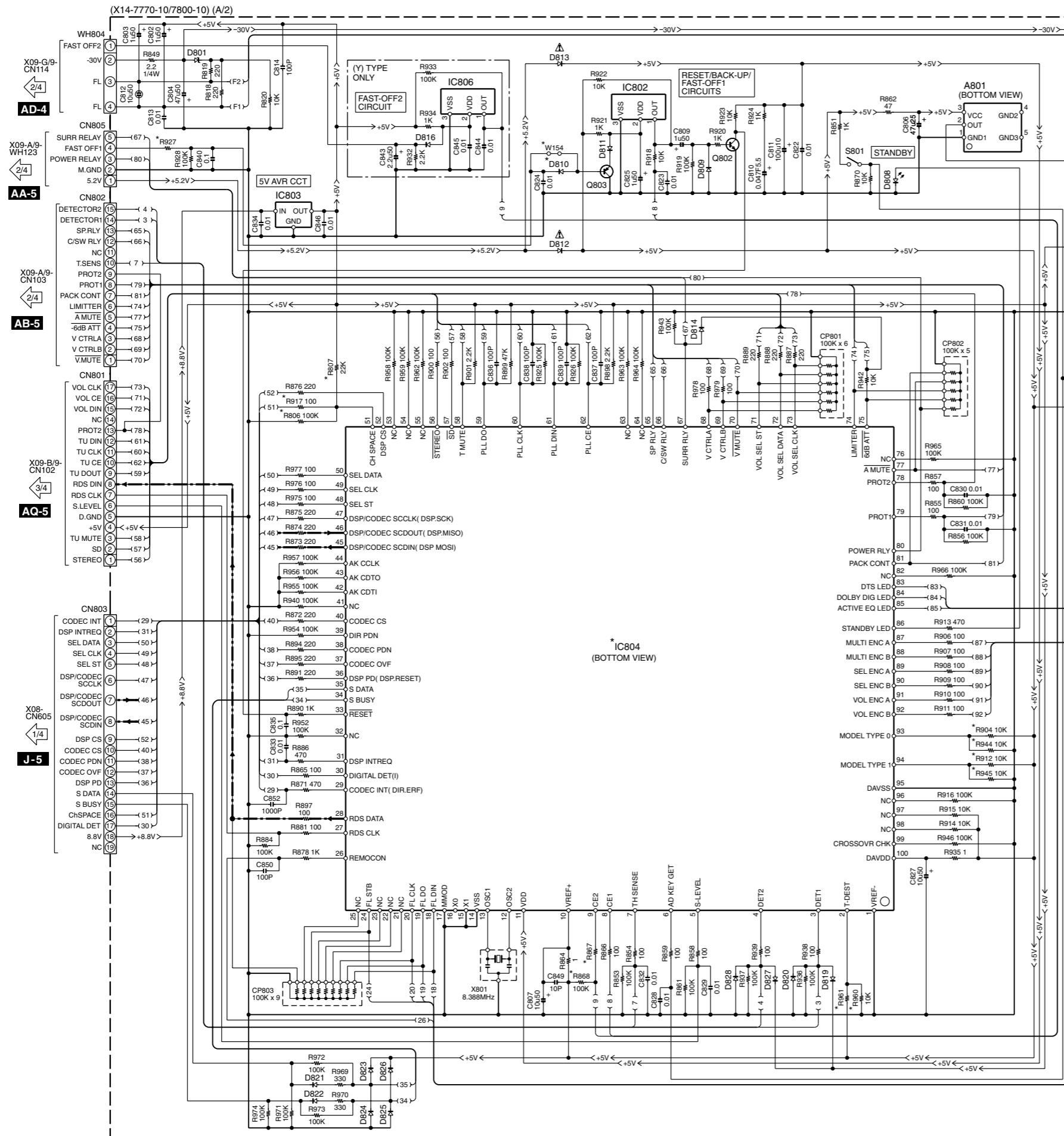

(X14-7770-10)

MODEL NAME	DESTINATION COUNTRY	ABB.	UNIT No.	D810	ED801	IC804	R806	R807	R867	R868	R904	R912	R917	R927	R944	R945	R960	R961	W154	
VR-806/806-S	U.S.A.	K1	0-10	YES	11-MT-143GNK	MN101C49KLG	YES	NO	100	YES	YES	YES	YES	NO	56K	NO	NO	YES	NO	NO
	CANADA	P1,P2																		
KRF-V6080D	PX	Y1	2-91	YES	11-MT-143GNK	MN101C49KLG	NO	YES	10K	NO	YES	YES	YES	NO	150K	NO	NO	NO	10K	YES
	EUROPE	E6	2-71	NO	11-MT-143GNK	MN101C49KLG	YES	NO	100	YES	YES	YES	YES	NO	150K	NO	NO	NO	10K	YES
KRF-V6080D-S	PX	Y2	2-91	YES	11-MT-143GNK	MN101C49KLG	NO	YES	10K	NO	YES	YES	YES	NO	150K	NO	NO	NO	10K	YES
	EUROPE	E2	0-71	NO	11-MT-143GNK	MN101C49KLG	NO	YES	100	YES	YES	YES	YES	NO	160K	NO	NO	YES	30K	YES
KRF-V5080D	PX	Y4	2-92	YES	11-MT-143GNK	MN101C49KLG	NO	YES	10K	NO	YES	YES	YES	NO	150K	NO	NO	NO	10K	YES
	EUROPE	E4	2-72	NO	11-MT-143GNK	MN101C49KLG	YES	NO	100	YES	NO	NO	YES	YES	62K	YES	NO	NO	10K	YES
KRF-V5080D-S	PX	Y5	2-92	YES	11-MT-143GNK	MN101C49KLG	NO	YES	10K	NO	YES	YES	YES	NO	150K	NO	NO	NO	10K	YES
	EUROPE	X5	0-72	NO	11-MT-143GNK	MN101C49KLG	NO	YES	100	YES	NO	NO	YES	YES	62K	YES	NO	YES	10K	YES
	EUROPE	E5	2-72	NO	11-MT-143GNK	MN101C49KLG	YES	NO	100	YES	NO	YES	NO	150K	YES	NO	NO	10K	YES	

(X14-7800-10)

MODEL NAME	DESTINATION COUNTRY	ABB.	UNIT No.	D810	ED801	IC804	R806	R807	R867	R868	R904	R912	R917	R927	R944	R945	R960	R961	W154	
VR-804-S	U.S.A.	K3	0-10	YES	11MT129GNK	MN101C49KLE	YES	NO	100	YES	YES	YES	YES	NO	56K	NO	NO	YES	NO	NO
	CANADA	P3																		
KRF-V4080D	EUROPE	E6	2-71	NO	11MT129GNK	MN101C49KLE	YES	NO	100	YES	YES	YES	YES	NO	150K	NO	NO	NO	10K	YES
KRF-V4080D-S	AUSTRALIA	X7	0-71	NO	11MT129GNK	MN101C49KLE	NO	YES	100	YES	YES	YES	YES	NO	160K	NO	NO	YES	30K	YES
	EUROPE	E7	2-71	NO	11MT129GNK	MN101C49KLE	YES	NO	100	YES	YES	YES	YES	NO	150K	NO	NO	NO	10K	YES
	PX	Y3	0-22	YES	11MT129GNK	MN101C49KLE	NO	YES	10K	NO	NO	YES	YES	NO	62K	YES	YES	10K	NO	NO
KRF-V5580D-S	AUSTRALIA	X3	0-72	NO	11MT129GNK	MN101C49KLE	NO	YES	100	YES	NO	NO	NO	160K	YES	YES	30K	YES		
	EUROPE	E3	2-72	NO	11MT129GNK	MN101C49KLE	YES	NO	100	YES	NO	NO	NO	150K	YES	NO	NO	10K	YES	

- IC801 : MN12510F or MN12510FNOPB
- IC802, 806 : S-80840CNY
- IC803 : X86202P502TH
- IC804 : *
- D801 : MTZJ6.2(B) or RD6.2S(B)
- D802-804, 809-811, 814, 816, 819-828 : 1SS133 or HSS104A
- D805-808 : B30-2545-05
- D812, 813 : RB441Q-40
- Q802, 804-807 : 2SC1740S(Q,R) or 2SC2785(F,E)
- Q803 : 2SA933AS(Q,R) or 2SA1175(F,E)

KRF-V4080D/V5080D/V5580D/V6080D (4/4)
VR-804/806 (4/4)

KRF-V4080D/V5080D/V5580D/V6080D/VR-804-S/806

(X14-7770-10/7800-10) (A/2)

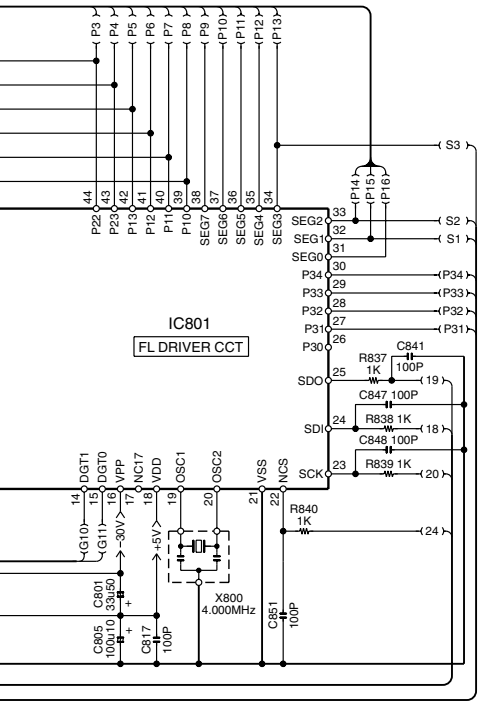
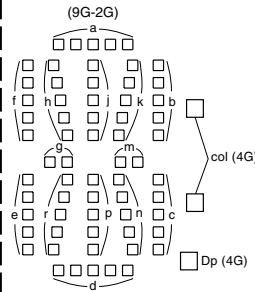
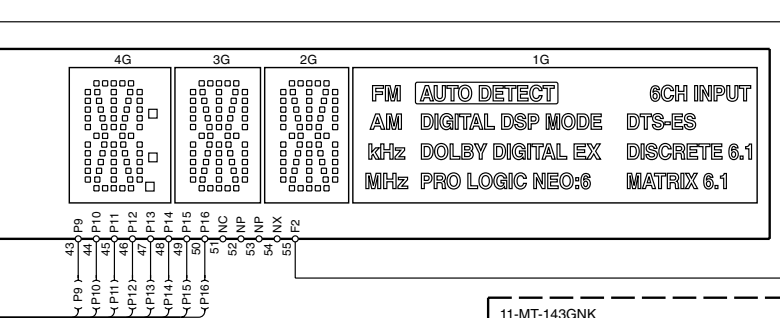

	11G	10G	9G	8G	7G	6G	5G	4G	3G	2G	1G
P1	SP D (M)	L	a	a	a	a	a	a	a	a	FM
P2	CLIP	C	i	j	j	j	j	j	j	j	AM
P3	MUTE	R	h	h	h	h	h	h	h	h	kHz
P4	tone	LFE	k	k	k	k	k	k	k	k	MHz
P5	LOUDNESS	SW	b	b	b	b	b	b	b	b	AUTO DETECT
P6	PTY	LS	f	f	f	f	f	f	f	f	DIGITAL
P7	RDS	S	g	g	g	g	g	g	g	g	6CH INPUT
P8	AUTO	BS	m	m	m	m	m	m	m	m	DSP MODE
P9	ST.	RS	c	c	c	c	c	c	c	c	DOLBY DIGITAL
P10	TUNED	(L)	e	e	e	e	e	e	e	e	EX
P11	-	(C)	r	r	r	r	r	r	r	r	PRO LOGIC
P12	-	(R)	n	n	n	n	n	n	n	n	NEO:6
P13	-	(SW)	p	p	p	p	p	p	p	p	DTS
P14	-	(LS)	d	d	d	d	d	d	d	d	-ES
P15	-	(BS)	-	-	-	-	-	col	-	-	DISCRETE 6.1
P16	-	(RS)	-	-	-	-	-	Dp	-	-	MATRIX 6.1

	11G	10G	9G	8G	7G	6G	5G	4G	3G	2G	1G
P1	SP D (M)	L	a	a	a	a	a	a	a	a	FM
P2	A	C	i	j	j	j	j	j	j	j	AM
P3	B	R	h	h	h	h	h	h	h	h	kHz
P4	MUTE	SL	k	k	k	k	k	k	k	k	kHz
P5	CLIP	S	b	b	b	b	b	b	b	b	AUTO
P6	CINEMA EQ.	SR	f	f	f	f	f	f	f	f	MEMO.
P7	-	LFE	g	g	g	g	g	g	g	g	ST.
P8	-	SW	m	m	m	m	m	m	m	m	TUNED
P9	RDS	(L)	c	c	c	c	c	c	c	c	AUTO DETECT
P10	PTY	(C)	e	e	e	e	e	e	e	e	DTS
P11	96kHz	(R)	r	r	r	r	r	r	r	r	DOLBY DIGITAL
P12	tone	(SL)	n	n	n	n	n	n	n	n	PRO LOGIC
P13	LOUDNESS	(S)	p	p	p	p	p	p	p	p	DIGITAL
P14	-	(SR)	d	d	d	d	d	d	d	d	6CH INPUT
P15	-	(SW)	-	-	-	-	-	col	-	-	DSP
P16	-	-	-	-	-	-	-	Dp	-	-	STEREO

CAUTION: For continued safety, replace safety critical components only with manufacturer's recommended parts (refer to parts list). Δ indicates safety critical components. For continued protection against risk of fire, replace only with same type and rating fuse(s). To reduce the risk of electric shock, leakage-current or resistance measurements shall be carried out (exposed parts are acceptably insulated from the supply circuit) before the appliance is returned to the customer.

The DC voltage is an actual reading measured with a high impedance type voltmeter with no signal input. The measurement value may vary depending on the measuring instruments used or on the product.

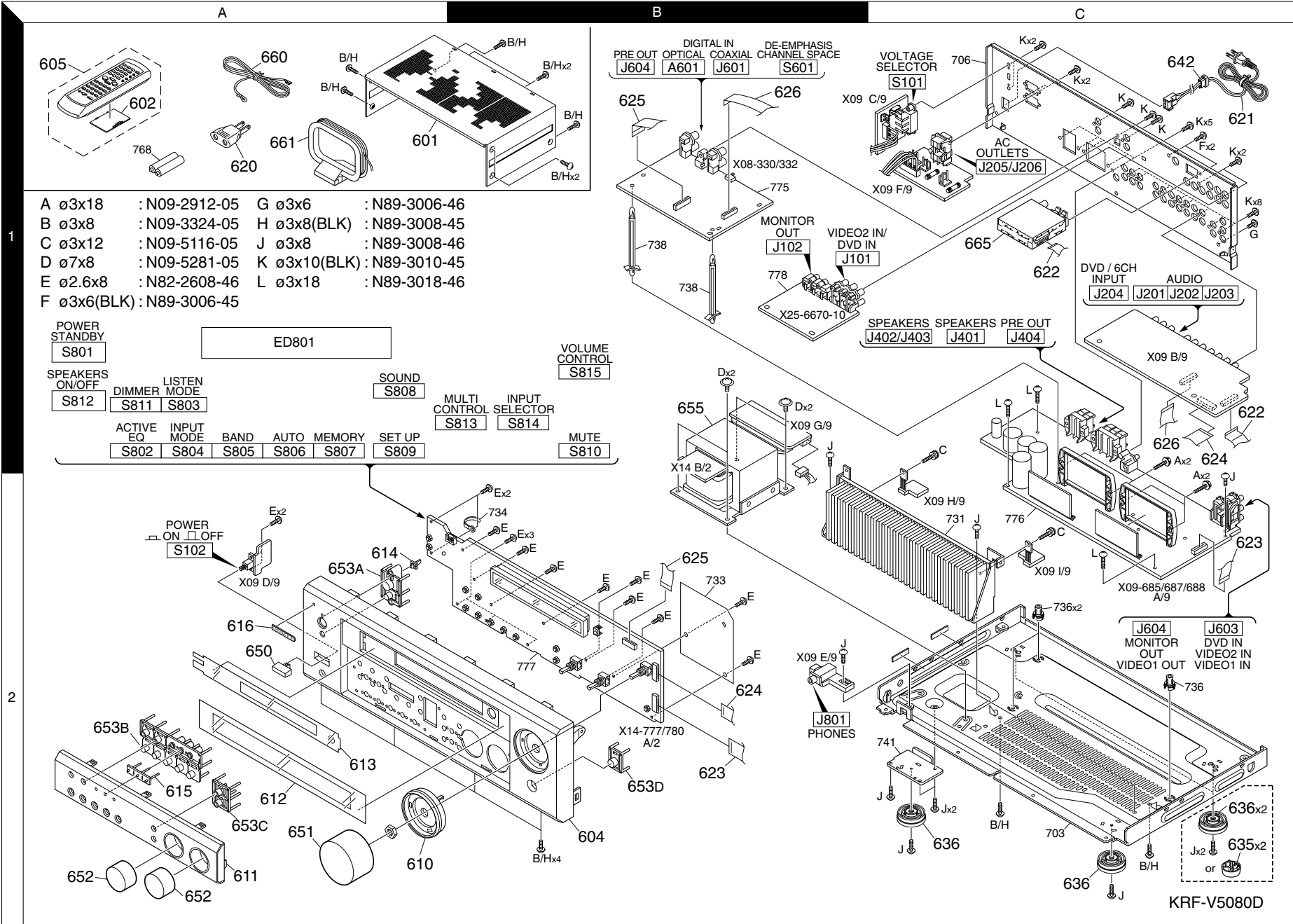

Parts with exploded numbers larger than 700 are not supplied.

* New Parts
Parts without **Parts No.** are not supplied.
Les articles non mentionnés dans le **Parts No.** ne sont pas fournis.
Teile ohne **Parts No.** werden nicht geliefert.

①

Ref. No	Add-ress	New Parts	Parts No.	Description	Desti-nation	Re-marks
KRF-V4080D/V4080D-S/V5080D/V5080D-S KRF-V5580D-S/V6080D/V6080D-S/VR-804-S/806/806-S						
601	1A		A01-3844-01	METALLIC CABINET	E1E4Y4	
601	1A		A01-3844-01	METALLIC CABINET	E6	
601	1A		A01-3844-01	METALLIC CABINET	K1P1Y1	
601	1A		A01-3848-01	METALLIC CABINET	E5Y5X5	
601	1A		A01-3848-01	METALLIC CABINET	K2P2Y2	
601	1A		A01-3848-01	METALLIC CABINET	X2E2	
601	1A		A01-3848-01	METALLIC CABINET	X7E7	
601	1A		A01-3848-01	METALLIC CABINET	68	
602	1A		A09-1178-08	BATTERY COVER	45689	
602	1A		A09-1274-08	BATTERY COVER	7	
604	2B	*	A60-2375-01	PANEL	K1P1	
604	2B	*	A60-2376-01	PANEL	K2P2	
604	2B	*	A60-2376-01	PANEL	8	
604	2B	*	A60-2379-01	PANEL	E4Y4E6	
604	2B	*	A60-2379-01	PANEL	Y1E1	
604	2B	*	A60-2380-01	PANEL	E5Y5X5	
604	2B	*	A60-2380-01	PANEL	X7E7	
604	2B	*	A60-2380-01	PANEL	Y2X2E2	
604	2B	*	A60-2380-01	PANEL	6	
605	1A		A70-1611-05	REMOTE CONTROLLER ASSY	X7	
605	1A	*	A70-1611-05	REMOTE CONTROLLER ASSY	Y4Y5X5	
605	1A		A70-1612-05	REMOTE CONTROLLER ASSY	X3Y3	
605	1A		A70-1612-05	REMOTE CONTROLLER ASSY	89	
605	1A		A70-1613-05	REMOTE CONTROLLER ASSY	E4E5	
605	1A		A70-1613-05	REMOTE CONTROLLER ASSY	E6E7	
605	1A		A70-1614-05	REMOTE CONTROLLER ASSY	E3	
605	1A		A70-1617-05	REMOTE CONTROLLER ASSY	Y1Y2X2	
605	1A		A70-1618-05	REMOTE CONTROLLER ASSY	E1E2	
-		*	B60-5439-00	INST. MANUAL (EN)	Y4Y5X5	
-		*	B60-5439-00	INST. MANUAL (EN)	9	
-		*	B60-5440-00	INST. MANUAL,EN/FR/GE/NE/IT/ES	E1E2	
-		*	B60-5441-00	INST. MANUAL (TC)	Y1Y2	
-		*	B60-5442-00	INST. MANUAL (EN)	Y1Y2X2	
-		*	B60-5443-00	INST. MANUAL (FR)	P1P2	
-		*	B60-5444-00	INST. MANUAL (EN)	X3Y3X7	
-		*	B60-5444-00	INST. MANUAL (EN)	8	
-		*	B60-5445-00	INST. MANUAL (FR)	P3	
-		*	B60-5446-00	INST. MANUAL,EN/FR/GE/NE/IT/ES	E3E6E7	
-		*	B60-5449-00	INST. MANUAL (TC)	Y3	
-		*	B60-5451-00	INST. MANUAL,EN/FR/GE/NE/IT/ES	E4E5	
-		*	B60-5452-00	INST. MANUAL (TC)	Y5	
610	2A	*	B07-2685-03	ESCUTCHEON	E5Y5X5	
610	2A	*	B07-2685-03	ESCUTCHEON	K2P2Y2	
610	2A	*	B07-2685-03	ESCUTCHEON	X2E2	
610	2A	*	B07-2685-03	ESCUTCHEON	X7E7	
610	2A	*	B07-2685-03	ESCUTCHEON	68	
610	2A	*	B07-2688-03	ESCUTCHEON	E1E4Y4	
610	2A	*	B07-2688-03	ESCUTCHEON	E6	
610	2A	*	B07-2688-03	ESCUTCHEON	K1P1Y1	
611	2A	*	B07-2686-01	ESCUTCHEON	E1E4Y4	
611	2A	*	B07-2686-01	ESCUTCHEON	E6	
611	2A	*	B07-2686-01	ESCUTCHEON	K1P1Y1	
611	2A	*	B07-2687-01	ESCUTCHEON	E5Y5X5	

L : Scandinavia K : USA P : Canada R : Mexico C : China I : Malaysia
Y : PX(Far East,Hawaii) T : England E : Europe G : Germany V : China(Shanghai)
Y : AAFES(Europe) X : Australia Q : Russia H : Korea M : Other Areas Δ indicates safety critical components.

* New Parts
Parts without **Parts No.** are not supplied.
Les articles non mentionnés dans le **Parts No.** ne sont pas fournis.
Teile ohne **Parts No.** werden nicht geliefert.

②

Ref. No	Add-ress	New Parts	Parts No.	Description	Desti-nation	Re-marks
611	2A	*	B07-2687-01	ESCUTCHEON	K2P2Y2	
611	2A	*	B07-2687-01	ESCUTCHEON	X2E2	
611	2A	*	B07-2687-01	ESCUTCHEON	X7E7	
611	2A	*	B07-2687-01	ESCUTCHEON	68	
612	2A	*	B10-3997-02	FRONT GLASS	K1P1	
612	2A	*	B10-3998-02	FRONT GLASS	Y1	
612	2A	*	B10-3999-02	FRONT GLASS	E1	
612	2A	*	B10-4000-02	FRONT GLASS	8	
612	2A	*	B10-5501-02	FRONT GLASS	E6	
612	2A	*	B10-5502-02	FRONT GLASS	X3Y3	
612	2A	*	B10-5503-02	FRONT GLASS	E3	
612	2A	*	B10-5504-02	FRONT GLASS	Y4	
612	2A	*	B10-5505-02	FRONT GLASS	E4	
612	2A	*	B10-5515-02	FRONT GLASS	X7	
612	2A	*	B10-5516-02	FRONT GLASS	K2P2	
612	2A	*	B10-5517-02	FRONT GLASS	Y2X2	
612	2A	*	B10-5518-02	FRONT GLASS	E2	
612	2A	*	B10-5519-02	FRONT GLASS	E7	
612	2A	*	B10-5520-02	FRONT GLASS	Y5X5	
612	2A	*	B10-5521-02	FRONT GLASS	E5	
613	2A		B11-1568-13	COLOR FILTER		
614	2A	*	B12-0482-04	INDICATOR		
615	2A	*	B12-0483-04	INDICATOR		
616	2A	*	B43-0336-04	BADGE		
Δ 620	1A	*	E03-0508-05	AC PLUG ADAPTER	Y1Y2Y3	
Δ 620	1A	*	E03-0508-05	AC PLUG ADAPTER	Y4Y5	
Δ 621	1C	*	E30-2717-05	AC POWER CORD	X2X3X5	
Δ 621	1C	*	E30-2717-05	AC POWER CORD	X7	
Δ 621	1C	*	E30-2941-05	AC POWER CORD	89	
Δ 621	1C	*	E30-2942-05	AC POWER CORD	E1E2E3	
Δ 621	1C	*	E30-2942-05	AC POWER CORD	E4E5	
Δ 621	1C	*	E30-2942-05	AC POWER CORD	E6E7	
Δ 621	1C	*	E30-7313-05	AC POWER CORD	Y1Y2Y3	
Δ 621	1C	*	E30-7313-05	AC POWER CORD	Y4Y5	
622	1C		E35-2643-05	FLAT CABLE (15P,120)		
623	2B,2C		E35-2792-05	FLAT CABLE (15P,220)		
624	2B,1C		E35-3306-15	FLAT CABLE (17P,260)		
625	1B,2B		E35-3468-05	FLAT CABLE (19P,558)		
626	1C		E35-3469-05	FLAT CABLE (21P,258)	468	
626	1C	*	E35-3632-05	FLAT CABLE (25P)	579	
-		*	H10-7858-04	POLYSTYRENE FOAMED FIXTURE	7	
-		*	H10-7916-11	POLYSTYRENE FOAMED FIXTURE (L)		
-		*	H10-7917-11	POLYSTYRENE FOAMED FIXTURE (R)		
-		*	H12-3633-04	PACKING FIXTURE	7	
-		*	H25-0232-04	PROTECTION BAG (235X350X0.03)		
-		*	H25-0391-04	PROTECTION BAG		
-		*	H50-4895-04	ITEM CARTON CASE	K1P1	
-		*	H50-4896-04	ITEM CARTON CASE	K2P2	
-		*	H50-4897-04	ITEM CARTON CASE	Y1	
-		*	H50-4898-04	ITEM CARTON CASE	Y2	
-		*	H50-4899-04	ITEM CARTON CASE	8	
-		*	H50-4900-04	ITEM CARTON CASE	E6	
-		*	H50-4901-04	ITEM CARTON CASE	E7	
-		*	H50-4902-04	ITEM CARTON CASE	Y3	

L : Scandinavia K : USA P : Canada R : Mexico C : China I : Malaysia
Y : PX(Far East,Hawaii) T : England E : Europe G : Germany V : China(Shanghai)
Y : AAFES(Europe) X : Australia Q : Russia H : Korea M : Other Areas Δ indicates safety critical components.

PARTS LIST

KRF-V4080D/V5080D/V5580D-S/V6080D/VR-804-S/806

* New Parts

Parts without **Parts No.** are not supplied.
Les articles non mentionnés dans le **Parts No.** ne sont pas fournis.
Teile ohne **Parts No.** werden nicht geliefert.



Ref. No	Address	New Parts	Parts No.	Description	Destination	Remarks
-		*	H50-4903-04	ITEM CARTON CASE	X3	
-		*	H50-4904-04	ITEM CARTON CASE	E3	
-		*	H50-4905-04	ITEM CARTON CASE	Y4	
-		*	H50-4906-04	ITEM CARTON CASE	X5	
-		*	H50-4907-04	ITEM CARTON CASE	E4	
-		*	H50-4920-04	ITEM CARTON CASE	X2	
-		*	H50-4921-04	ITEM CARTON CASE	E1	
-		*	H50-4922-04	ITEM CARTON CASE	E2	
-		*	H50-4923-04	ITEM CARTON CASE	X7	
-		*	H50-4925-04	ITEM CARTON CASE	E5	
-		*	H50-4926-04	ITEM CARTON CASE	Y5	
-			J61-0307-05	WIRE BAND		
635	2C		J02-1013-05	FOOT	X3Y3Y4	
635	2C		J02-1013-05	FOOT	Y1Y2X2	
635	2C		J02-1013-05	FOOT	Y5X5X7	
635	2C		J02-1013-05	FOOT	89	
635	2C		J02-1464-03	FOOT	E1E2E3	
635	2C		J02-1464-03	FOOT	E4E5E6	
635	2C		J02-1464-03	FOOT	E7	
636	2C		J02-1464-03	FOOT		
642	1C		J42-0349-05	POWER CORD BUSHING		
650	2A	*	K27-2525-14	KNOB (BUTTON)	E4Y4E6	
650	2A	*	K27-2525-14	KNOB (BUTTON)	Y1E1	
650	2A	*	K27-2526-04	KNOB (BUTTON)	E5Y5X5	
650	2A	*	K27-2526-04	KNOB (BUTTON)	X7E7	
650	2A	*	K27-2526-04	KNOB (BUTTON)	Y2X2E2	
650	2A	*	K27-2526-04	KNOB (BUTTON)	6	
651	2A	*	K29-8350-14	KNOB	E1E4Y4	
651	2A	*	K29-8350-14	KNOB	E6	
651	2A	*	K29-8350-14	KNOB	K1P1Y1	
651	2A	*	K29-8351-04	KNOB	E5Y5X5	
651	2A	*	K29-8351-04	KNOB	K2P2Y2	
651	2A	*	K29-8351-04	KNOB	X2E2	
651	2A	*	K29-8351-04	KNOB	X7E7	
651	2A	*	K29-8351-04	KNOB	68	
652	2A	*	K29-8352-14	KNOB	E1E4Y4	
652	2A	*	K29-8352-14	KNOB	E6	
652	2A	*	K29-8352-14	KNOB	K1P1Y1	
652	2A	*	K29-8353-04	KNOB	E5Y5X5	
652	2A	*	K29-8353-04	KNOB	K2P2Y2	
652	2A	*	K29-8353-04	KNOB	X2E2	
652	2A	*	K29-8353-04	KNOB	X7E7	
652	2A	*	K29-8353-04	KNOB	68	
652	2A	*	K29-8354-01	KNOB	E1E4Y4	
652	2A,2B	*	K29-8354-01	KNOB	E6	
652	2A,2B	*	K29-8354-01	KNOB	K1P1Y1	
652	2A,2B	*	K29-8355-01	KNOB	E5Y5X5	
652	2A,2B	*	K29-8355-01	KNOB	K2P2Y2	
652	2A,2B	*	K29-8355-01	KNOB	X2E2	
652	2A,2B	*	K29-8355-01	KNOB	X7E7	
652	2A,2B	*	K29-8355-01	KNOB	68	
655	1B		L07-2922-05	POWER TRANSFORMER	89	
655	1B		L07-2923-05	POWER TRANSFORMER	Y1Y2Y3	
655	1B		L07-2923-05	POWER TRANSFORMER	Y4Y5	

L: Scandinavia K: USA P: Canada R: Mexico C: China I: Malaysia
Y: PX(Far East,Hawaii) T: England E: Europe G: Germany V: China(Shanghai)
Y: AAFES(Europe) X: Australia Q: Russia H: Korea M: Other Areas indicates safety critical components.

* New Parts

Parts without **Parts No.** are not supplied.
Les articles non mentionnés dans le **Parts No.** ne sont pas fournis.
Teile ohne **Parts No.** werden nicht geliefert.



Ref. No	Address	New Parts	Parts No.	Description	Destination	Remarks
655	1B		L07-2924-05	POWER TRANSFORMER	X2X3X5	
655	1B		L07-2924-05	POWER TRANSFORMER	X7	
655	1B		L07-3210-05	POWER TRANSFORMER	E1E2E3	
655	1B		L07-3210-05	POWER TRANSFORMER	E4E5	
655	1B		L07-3210-05	POWER TRANSFORMER	E6E7	
660	1A		T90-0877-05	LEAD WIRE ANTENNA	4567	
660	1A	*	T90-0905-05	LEAD WIRE ANTENNA	89	
661	1A		T90-0893-05	LOOP ANTENNA		
665	1C	*	W02-2970-15	TUNER ASSY	89	
665	1C		W02-2971-05	TUNER ASSY	X3X5X7	
665	1C		W02-2971-05	TUNER ASSY	Y1Y2Y3	
665	1C		W02-2971-05	TUNER ASSY	Y4Y5X2	
665	1C		W02-2972-05	TUNER ASSY	E1E2E3	
665	1C		W02-2972-05	TUNER ASSY	E4E5	
665	1C		W02-2972-05	TUNER ASSY	E6E7	
SURROUND (X08-3300-10/X08-3320-10)						
C601			CK73GB1H103K	CHIP C	0.010UF	K
C602			CK73GB1H102K	CHIP C	1000PF	K
C603			CC73GCH1H220J	CHIP C	22PF	J
C604			CC73GCH1H270J	CHIP C	27PF	J
C605,606			CK73GB1H103K	CHIP C	0.010UF	K
C607			CC73GCH1H220J	CHIP C	22PF	J
C608			CK73GB1H102K	CHIP C	1000PF	K
C609,610			CK73GB1H103K	CHIP C	0.010UF	K
C611			CK73GB1H102K	CHIP C	1000PF	K
C612			CK73GB1H103K	CHIP C	0.010UF	K
C613			CE04LW1H2R2M	ELECTRO	2.2UF	50WV
C614			CK73GB1H103K	CHIP C	0.010UF	K
C615			CC73GCH1H471J	CHIP C	470PF	J
C616			CE04LW1E470M	ELECTRO	47UF	25WV
C617,618			CK73GB1H103K	CHIP C	0.010UF	K
C619			CK73FB1E104K	CHIP C	0.10UF	K
C621			CE04KW1H2R2M	ELECTRO	2.2UF	50WV
C622,623			CK73GB1H103K	CHIP C	0.010UF	K
C624			CC73GCH1H101J	CHIP C	100PF	J
C624			CC73GCH1H101J	CHIP C	100PF	J
C625			CE04LW1C470M	ELECTRO	47UF	16WV
C626			CK73GB1H102K	CHIP C	1000PF	K
C627			CE04LW1C101M	ELECTRO	100UF	16WV
C631			CK73FB1E104K	CHIP C	0.10UF	K
C632,633			CC73GCH1H221J	CHIP C	220PF	J
C634,635			CC73GCH1H220J	CHIP C	22PF	J
C636,637			CK73GB1H472K	CHIP C	4700PF	K
C654			CE04LW1H100M	ELECTRO	10UF	50WV
C656			CE04LW1E470M	ELECTRO	47UF	25WV
C657			CE04LW1A101M	ELECTRO	100UF	10WV
C659			CE04KW1A101M	ELECTRO	100UF	10WV
C660			CC73GCH1H820J	CHIP C	82PF	J
C661			CK73GB1H103K	CHIP C	0.010UF	K
C662			CE04LW1A101M	ELECTRO	100UF	10WV
C663			CK73GB1H103K	CHIP C	0.010UF	K
C665			CC73GCH1H330J	CHIP C	33PF	J
C666			CK73FB1E104K	CHIP C	0.10UF	K
C667			CE04KW1C472M	ELECTRO	4700UF	16WV

L: Scandinavia K: USA P: Canada R: Mexico C: China I: Malaysia
Y: PX(Far East,Hawaii) T: England E: Europe G: Germany V: China(Shanghai)
Y: AAFES(Europe) X: Australia Q: Russia H: Korea M: Other Areas indicates safety critical components.

KRF-V4080D/V5080D/V5580D-S/V6080D/VR-804-S/806
PARTS LIST

* New Parts
Parts without **Parts No.** are not supplied.
Les articles non mentionnés dans le **Parts No.** ne sont pas fournis.
Teile ohne **Parts No.** werden nicht geliefert.

5

Ref. No	Add-ress	New Parts	Parts No.	Description	Desti-nation	Re-marks
C668,669			CK73FB1E104K	CHIP C	0.10UF	K
C670			CE04LW1H100M	ELECTRO	10UF	50WV
C671			CC73GCH1H220J	CHIP C	22PF	J
C671			CC73GCH1H470J	CHIP C	47PF	J
C672			CC73GCH1H220J	CHIP C	22PF	J
C673			CE04KW1H220M	ELECTRO	22UF	50WV
C675,676			CC73GCH1H220J	CHIP C	22PF	J
C681,682			CC73GCH1H220J	CHIP C	22PF	J
C683			CK73FB1E104K	CHIP C	0.10UF	K
C686,687			CE04KW1H220M	ELECTRO	22UF	50WV
C688			CK73FB1E104K	CHIP C	0.10UF	K
C700			CC73GCH1H470J	CHIP C	47PF	J
C701,702			CE04LW1H100M	ELECTRO	10UF	50WV
C703,704			CK73GB1H222K	CHIP C	2200PF	K
C705,706			CK73GB1H182K	CHIP C	1800PF	K
C707,708			CC73GCH1H101J	CHIP C	100PF	J
C709			CK73GB1H472K	CHIP C	4700PF	K
C710			CC73GCH1H101J	CHIP C	100PF	J
C711,712			CE04LW1H100M	ELECTRO	10UF	50WV
C713,714			CK73GB1H821K	CHIP C	820PF	K
C715,716			CK73GB1H222K	CHIP C	2200PF	K
C717,718			CC73GCH1H101J	CHIP C	100PF	J
C719			CC73GCH1H470J	CHIP C	47PF	J
C720			CC73GCH1H330J	CHIP C	33PF	J
C721,722			CE04LW1H100M	ELECTRO	10UF	50WV
C723			CK73GB1H222K	CHIP C	2200PF	K
C724			CK73GB1H822K	CHIP C	8200PF	K
C725			CK73GB1H182K	CHIP C	1800PF	K
C726			CK73GB1H822K	CHIP C	8200PF	K
C727,728			CC73GCH1H101J	CHIP C	100PF	J
C729,730			CE04LW1H4R7M	ELECTRO	4.7UF	50WV
C731,732			CC73GCH1H100D	CHIP C	10PF	D
C733,734			CE04LW1H220M	ELECTRO	22UF	50WV
C735,736			CC73GCH1H101J	CHIP C	100PF	J
C737,738			CC73GCH1H220J	CHIP C	22PF	J
C739,740			CE04LW1H100M	ELECTRO	10UF	50WV
C741			CK73GB1H102K	CHIP C	1000PF	K
C742			CC73GCH1H101J	CHIP C	100PF	J
C744			CC73GCH1H101J	CHIP C	100PF	J
C761,762			CE04LW1H100M	ELECTRO	10UF	50WV
C763,764			CK73GB1H182K	CHIP C	1800PF	K
C765,766			CK73GB1H222K	CHIP C	2200PF	K
C767,768			CC73GCH1H101J	CHIP C	100PF	J
C771,772			CK73GB1H821K	CHIP C	820PF	K
C773,774			CE04LW1H100M	ELECTRO	10UF	50WV
C775,776			CK73GB1H102K	CHIP C	1000PF	K
C777,778			CC73GCH1H221J	CHIP C	220PF	J
C781,782			CE04LW1H4R7M	ELECTRO	4.7UF	50WV
C791,792			CC73GCH1H471J	CHIP C	470PF	J
C901-906			CC73GCH1H470J	CHIP C	47PF	J
C907,908			CC73GCH1H101J	CHIP C	100PF	J
C909,910			CK73GB1H103K	CHIP C	0.010UF	K
C912,913			CE04LW1E470M	ELECTRO	47UF	25WV
C915			CE04EW1C471M	ELECTRO	470UF	16WV
C916			CK73FB1E104K	CHIP C	0.10UF	K

L : Scandinavia K : USA P : Canada R : Mexico C : China I : Malaysia
Y : PX(Far East,Hawaii) T : England E : Europe G : Germany V : China(Shanghai)
Y : AAFES(Europe) X : Australia Q : Russia H : Korea M : Other Areas Δ indicates safety critical components.

* New Parts
Parts without **Parts No.** are not supplied.
Les articles non mentionnés dans le **Parts No.** ne sont pas fournis.
Teile ohne **Parts No.** werden nicht geliefert.

6

Ref. No	Add-ress	New Parts	Parts No.	Description	Desti-nation	Re-marks
C917,918			CC73GCH1H101J	CHIP C	100PF	J
C919,920			CK73GB1H103K	CHIP C	0.010UF	K
CN601			E40-8484-05	FLAT CABLE CONNECTOR (21P)		468
CN601			E40-8601-05	FLAT CABLE CONNECTOR (25P)		579
CN605			E40-8483-05	FLAT CABLE CONNECTOR (19P)		
J601			E63-1294-05	PIN JACK		468
J602			E11-0293-05	MINIATURE PHONE JACK(2P)		
J604		*	E63-1297-05	PIN JACK		579
J901			E56-0049-05	CYLINDRICAL RECEPTACLE		7
X601			L77-2296-05	CRYSTAL RESONATOR(12.288MHZ)		
CP601,602			R90-0714-05	MULTI-COMP 10K X4		
CP603-605			R90-0728-05	MULTI-COMP 180 X4		
R601,602			RK73GB1J221J	CHIP R	220	J 1/16W
R603,604			RK73GB1J105J	CHIP R	1.0M	J 1/16W
R605			RK73GB1J103J	CHIP R	10K	J 1/16W
R608			RK73GB1J221J	CHIP R	220	J 1/16W
R609			RK73GB1J104J	CHIP R	100K	J 1/16W
R610			RK73GB1J221J	CHIP R	220	J 1/16W
R611,612			RK73GB1J332J	CHIP R	3.3K	J 1/16W
R613,614			RK73GB1J221J	CHIP R	220	J 1/16W
R615			RK73GB1J101J	CHIP R	100	J 1/16W
R615			RK73GB1J101J	CHIP R	100	J 1/16W
R623			RK73GB1J103J	CHIP R	10K	J 1/16W
R624			RK73GB1J221J	CHIP R	220	J 1/16W
R625,626			RK73GB1J332J	CHIP R	3.3K	J 1/16W
R627,628			RK73GB1J221J	CHIP R	220	J 1/16W
R629			RK73GB1J103J	CHIP R	10K	J 1/16W
R630			RK73GB1J333J	CHIP R	33K	J 1/16W
R631			RK73GB1J101J	CHIP R	100	J 1/16W
R632,633			RK73GB1J472J	CHIP R	4.7K	J 1/16W
R634			RK73GB1J471J	CHIP R	470	J 1/16W
R635			RK73GB1J750J	CHIP R	75	J 1/16W
R637,638			RK73GB1J220J	CHIP R	22	J 1/16W
R639			RK73GB1J183J	CHIP R	18K	J 1/16W
R640			R92-1946-05	METAL GLAZE	4.7	J 1/4W
Δ R641			RD14NB2E4R7J	RD	4.7	J 1/4W
R642			RK73GB1J220J	CHIP R	22	J 1/16W
R644			RK73GB1J750J	CHIP R	75	J 1/16W
R645,646			RK73GB1J102J	CHIP R	1.0K	J 1/16W
R647			RK73GB1J103J	CHIP R	10K	J 1/16W
R648			RK73GB1J102J	CHIP R	1.0K	J 1/16W
R651-656			RK73GB1J220J	CHIP R	22	J 1/16W
R657,658			RK73GB1J221J	CHIP R	220	J 1/16W
R663			RK73GB1J221J	CHIP R	220	J 1/16W
Δ R664			R92-1993-05	METAL GLAZE	560	J 1/4W
R665			RK73GB1J223J	CHIP R	22K	J 1/16W
Δ R666			RS14KB3D180J	FL-PROOF RS	18	J 2W
R667			RK73GB1J221J	CHIP R	220	J 1/16W
Δ R670			R92-1946-05	METAL GLAZE	4.7	J 1/4W
Δ R671			RD14NB2E1R0J	RD	1	J 1/4W
R672			RK73GB1J221J	CHIP R	220	J 1/16W
R673			RK73GB1J473J	CHIP R	47K	J 1/16W
R674			RK73GB1J472J	CHIP R	4.7K	J 1/16W

L : Scandinavia K : USA P : Canada R : Mexico C : China I : Malaysia
Y : PX(Far East,Hawaii) T : England E : Europe G : Germany V : China(Shanghai)
Y : AAFES(Europe) X : Australia Q : Russia H : Korea M : Other Areas Δ indicates safety critical components.

PARTS LIST

KRF-V4080D/V5080D/V5580D-S/V6080D/VR-804-S/806

* New Parts

Parts without **Parts No.** are not supplied.
Les articles non mentionnés dans le **Parts No.** ne sont pas fournis.
Teile ohne **Parts No.** werden nicht geliefert.

7

Ref. No	Address	New Parts	Parts No.	Description	Quantity	Unit	Desti-nation	Re-marks
R675			RK73GB1J221J	CHIP R	220	J	1/16W	
R676			RK73GB1J102J	CHIP R	1.0K	J	1/16W	
R677			RK73GB1J152J	CHIP R	1.5K	J	1/16W	
R678,679			RK73GB1J220J	CHIP R	22	J	1/16W	
R680			RK73GB1J471J	CHIP R	470	J	1/16W	
R683,684			RK73GB1J471J	CHIP R	470	J	1/16W	
R685			R92-1945-05	METAL GLAZE	1	J	1/4W	
R689			RK73GB1J220J	CHIP R	22	J	1/16W	
R690			RK73GB1J471J	CHIP R	470	J	1/16W	
R691			R92-1946-05	METAL GLAZE	4.7	J	1/4W	
R692			RK73GB1J220J	CHIP R	22	J	1/16W	
R693,694			RK73GB1J101J	CHIP R	100	J	1/16W	
R701,702			RK73GB1J222J	CHIP R	2.2K	J	1/16W	
R703,704			RK73GB1J104J	CHIP R	100K	J	1/16W	
R705,706			RK73GB1J222J	CHIP R	2.2K	J	1/16W	
R707,708			RK73GB1J103J	CHIP R	10K	J	1/16W	
R709,710			RK73GB1J472J	CHIP R	4.7K	J	1/16W	
R711,712			RK73GB1J332J	CHIP R	3.3K	J	1/16W	
R713,714			RK73GB1J104J	CHIP R	100K	J	1/16W	
R715,716			RK73GB1J222J	CHIP R	2.2K	J	1/16W	
R717,718			RK73GB1J272J	CHIP R	2.7K	J	1/16W	
R719,720			RK73GB1J562J	CHIP R	5.6K	J	1/16W	
R721			RK73GB1J222J	CHIP R	2.2K	J	1/16W	
R722			RK73GB1J153J	CHIP R	15K	J	1/16W	
R723,724			RK73GB1J104J	CHIP R	100K	J	1/16W	
R725			RK73GB1J222J	CHIP R	2.2K	J	1/16W	
R726			RK73GB1J183J	CHIP R	18K	J	1/16W	
R727,728			RK73GB1J103J	CHIP R	10K	J	1/16W	
R729			RK73GB1J472J	CHIP R	4.7K	J	1/16W	
R730			RK73GB1J562J	CHIP R	5.6K	J	1/16W	
R731,732			RK73GB1J104J	CHIP R	100K	J	1/16W	579
R733,734			RK73GB1J332J	CHIP R	3.3K	J	1/16W	579
R735-740			RK73GB1J103J	CHIP R	10K	J	1/16W	
R741-744			RK73GB1J221J	CHIP R	220	J	1/16W	
R745			RK73GB1J102J	CHIP R	1.0K	J	1/16W	
R746-748			RK73GB1J101J	CHIP R	100	J	1/16W	
R749,750			RK73GB1J272J	CHIP R	2.7K	J	1/16W	
R751			RK73GB1J472J	CHIP R	4.7K	J	1/16W	
R752			RK73GB1J562J	CHIP R	5.6K	J	1/16W	
R753			RK73GB1J472J	CHIP R	4.7K	J	1/16W	
R754			RK73GB1J562J	CHIP R	5.6K	J	1/16W	
R756-758			RK73GB1J181J	CHIP R	180	J	1/16W	
R759-762			RK73GB1J103J	CHIP R	10K	J	1/16W	579
R763,764			RK73GB1J104J	CHIP R	100K	J	1/16W	579
R765,766			RK73GB1J222J	CHIP R	2.2K	J	1/16W	579
R767,768			RK73GB1J103J	CHIP R	10K	J	1/16W	579
R769,770			RK73GB1J222J	CHIP R	2.2K	J	1/16W	579
R771,772			RK73GB1J221J	CHIP R	220	J	1/16W	579
R773,774			RK73GB1J104J	CHIP R	100K	J	1/16W	579
R775,776			RK73GB1J102J	CHIP R	1.0K	J	1/16W	579
R777-780			RK73GB1J222J	CHIP R	2.2K	J	1/16W	579
R781,782			RK73GB1J101J	CHIP R	100	J	1/16W	579
R791,792			RK73GB1J183J	CHIP R	18K	J	1/16W	
R793-804			RK73GB1J220J	CHIP R	22	J	1/16W	
R805-808			R92-1945-05	METAL GLAZE	1	J	1/4W	

L : Scandinavia K : USA P : Canada R : Mexico C : China I : Malaysia
Y : PX(Far East,Hawaii) T : England E : Europe G : Germany V : China(Shanghai)
Y : AAFES(Europe) X : Australia Q : Russia H : Korea M : Other Areas Δ indicates safety critical components .

* New Parts

Parts without **Parts No.** are not supplied.
Les articles non mentionnés dans le **Parts No.** ne sont pas fournis.
Teile ohne **Parts No.** werden nicht geliefert.

8

Ref. No	Address	New Parts	Parts No.	Description	Quantity	Unit	Desti-nation	Re-marks
R809-811			RK73FB2A1R0J	CHIP R	1	J	1/10W	
R812-814			R92-1945-05	METAL GLAZE	1	J	1/4W	
R901-904			RK73GB1J750J	CHIP R	75	J	1/16W	7
R905,906			RK73GB1J104J	CHIP R	100K	J	1/16W	7
R907,908			RK73GB1J750J	CHIP R	75	J	1/16W	7
R911			RK73GB1J472J	CHIP R	4.7K	J	1/16W	7
R912			RK73GB1J221J	CHIP R	220	J	1/16W	7
R915,916			RD14NB2E100J	RD	10	J	1/4W	7
R917			RK73GB1J103J	CHIP R	10K	J	1/16W	7
R921			RK73GB1J2R2J	CHIP R	2.2	J	1/16W	7
W900			R92-0679-05	CHIP R	0 OHM			
S601			S62-0034-05	SLIDE SWITCH				Y1Y2Y3
S601			S62-0034-05	SLIDE SWITCH				Y4Y5
D601			MA111	DIODE				
D602			DAN202U	DIODE				
D602			MA142WK	DIODE				
D602			1SS301	DIODE				
D603			DAP202U	DIODE				
D603			MA142WA	DIODE				
D603			1SS300	DIODE				
D604			HZU3.9(B2)	ZENER DIODE				
D604			UDZS3.9B	ZENER DIODE				
D605			DAN202U	DIODE				
D605			MA142WK	DIODE				
D605			1SS301	DIODE				
D606,607			HZU5.6(B2)	ZENER DIODE				
D606,607			UDZS5.6B	ZENER DIODE				
D608			MA111	DIODE				
Δ D609			D2SBA20F03	DIODE				
D610			HZU5.1(B2)	ZENER DIODE				
D610			UDZS5.1B	ZENER DIODE				
D611		*	HZU6.2(B2)	ZENER DIODE				579
D611			UDZS6.2B	ZENER DIODE				579
D612			HZU5.1(B2)	ZENER DIODE				579
D612			UDZS5.1B	ZENER DIODE				579
Δ D613,614			MA111	DIODE				
Δ D900-902			1SR154-400	DIODE				7
IC601			CS493263-CLG	MOS-IC				
IC601			CS493263-CLR	MOS-IC				
IC602			AK4586	MOS-IC				
IC603			TC7WU04FU	MOS-IC				
IC604			TC7WH123FU	MOS-IC				
IC605			TC74HCT7007AF	MOS-IC				
IC606			TC74HC07AF	MOS-IC				
IC607		*	AK4384	MOS-IC				579
Δ IC609			XC62EP2502MR	ANALOGUE IC				
Δ IC611			BA033LBSG	ANALOGUE IC				
Δ IC612			BA05T	ANALOGUE IC				
IC701-703			NJM4565MD	ANALOGUE IC				
IC704			NJM4565MD	ANALOGUE IC				579
IC705			NJU7311AM	MOS-IC				
IC707			NJM4565MD	ANALOGUE IC				
IC708			NJM4565MD	ANALOGUE IC				579

L : Scandinavia K : USA P : Canada R : Mexico C : China I : Malaysia
Y : PX(Far East,Hawaii) T : England E : Europe G : Germany V : China(Shanghai)
Y : AAFES(Europe) X : Australia Q : Russia H : Korea M : Other Areas Δ indicates safety critical components .

KRF-V4080D/V5080D/V5580D-S/V6080D/MR-804-S/806
PARTS LIST

* New Parts

Parts without **Parts No.** are not supplied.
Les articles non mentionnés dans le **Parts No.** ne sont pas fournis.
Teile ohne **Parts No.** werden nicht geliefert.



Table with columns: Ref. No, Address, New Parts, Parts No., Description, Destination, Remarks. Includes parts like MM1228XF, DTC124EUA, and CE04KW2A100M.

AUDIO (X09-6850-10/X09-6870-10/X09-6882-71)

* New Parts

Parts without **Parts No.** are not supplied.
Les articles non mentionnés dans le **Parts No.** ne sont pas fournis.
Teile ohne **Parts No.** werden nicht geliefert.



Table with columns: Ref. No, Address, New Parts, Parts No., Description, Destination, Remarks. Includes parts like CK45FF1H103Z, CE04KW1E101M, and CE04KW1H221J.

L: Scandinavia K: USA P: Canada R: Mexico C: China I: Malaysia Y: PX(Far East,Hawaii) T: England E: Europe G: Germany V: China(Shanghai) Y: AAFES(Europe) X: Australia Q: Russia H: Korea M: Other Areas indicates safety critical components.

L: Scandinavia K: USA P: Canada R: Mexico C: China I: Malaysia Y: PX(Far East,Hawaii) T: England E: Europe G: Germany V: China(Shanghai) Y: AAFES(Europe) X: Australia Q: Russia H: Korea M: Other Areas indicates safety critical components.

PARTS LIST

* New Parts

Parts without **Parts No.** are not supplied.
Les articles non mentionnés dans le **Parts No.** ne sont pas fournis.
Teile ohne **Parts No.** werden nicht geliefert.



Ref. No	Add-ress	New Parts	Parts No.	Description	Desti-nation	Re-marks
C273			CK45FB1H471K	CERAMIC 470PF K		
C274			CC45FSL1H331J	CERAMIC 330PF J		
C275			CE04KW1E470M	ELECTRO 47UF 25WV		
C276			CE04KW1A101M	ELECTRO 100UF 10WV		
C278			CE04KW1A101M	ELECTRO 100UF 10WV		
C279			CE04KW1E470M	ELECTRO 47UF 25WV		
C280			CE04KW1A101M	ELECTRO 100UF 10WV		
C281			CC45FSL1H101J	CERAMIC 100PF J		
C283-288			CC45FSL1H101J	CERAMIC 100PF J		
C290-299			CC45FSL1H101J	CERAMIC 100PF J		
C300			CC45FSL1H101J	CERAMIC 100PF J	457	
C301,302			CE04KW1H2R2M	ELECTRO 2.2UF 50WV		
C303,304			CK45FB1H471K	CERAMIC 470PF K		
C305,306			CC45FSL1H331J	CERAMIC 330PF J		
C307			CE04KW1H101M	ELECTRO 100UF 50WV		
C308			CQ93FMG1H473J	MYLAR 0.047UF J		
C309,310			CE04KW1A101M	ELECTRO 100UF 10WV		
C311			CE04KW1H4R7M	ELECTRO 4.7UF 50WV		
C312			CQ93FMG1H473J	MYLAR 0.047UF J		
C313			CC45FSL1H101J	CERAMIC 100PF J		
C316,317			CC45FSL1H100D	CERAMIC 10PF D		
C318			CE04KW1H101M	ELECTRO 100UF 50WV		
C319,320			CE04KW2A101M	ELECTRO 100UF 100WV		
C321,322			CK45FF1H472Z	CERAMIC 4700PF Z		
C323-328			C91-1573-05	MP-C 0.10UF J		
C329			CK45FF1H472Z	CERAMIC 4700PF Z		
C330			CC45FSL1H100D	CERAMIC 10PF D		
C332			CE04KW1A101M	ELECTRO 100UF 10WV		
C333			CE04KW1H4R7M	ELECTRO 4.7UF 50WV		
C334			CE04KW1H010M	ELECTRO 1.0UF 50WV		
C335			CE04LW1H100M	ELECTRO 10UF 50WV		
C336			CE04KW1A221M	ELECTRO 220UF 10WV		
C337			CE04HW1E100M	NP-ELEC 10UF 25WV		
C338			CE04KW1E470M	ELECTRO 47UF 25WV		
C339-343			CC45FSL1H101J	CERAMIC 100PF J	457	
C344-349			CC45FSL1H101J	CERAMIC 100PF J	468	
C350			CQ93FMG1H122J	MYLAR 1200PF J	579	
C351			CQ93FMG1H332J	MYLAR 3300PF J		
C351			CQ93FMG1H472J	MYLAR 4700PF J		
C352,353			CE04KW1H2R2M	ELECTRO 2.2UF 50WV		
C354			CK45FB1H471K	CERAMIC 470PF K		
C355,356			CK45FB1H102K	CERAMIC 1000PF K		
C357			CE04KW1H2R2M	ELECTRO 2.2UF 50WV		
C358			CQ93FMG1H104J	MYLAR 0.10UF J		
C359-364			CE04KW1H4R7M	ELECTRO 4.7UF 50WV		
C365-370			CE04KW1H2R2M	ELECTRO 2.2UF 50WV		
C371			CQ93FMG1H104J	MYLAR 0.10UF J	468	
C372			CQ93FMG1H332J	MYLAR 3300PF J	579	
C372			CQ93FMG1H472J	MYLAR 4700PF J		
C373,374			CQ93FMG1H104J	MYLAR 0.10UF J		
C375			CK45FF1H103Z	CERAMIC 0.010UF Z		
C376,377			CE04LW1A101M	ELECTRO 100UF 10WV		
C378			CE04KW1H010M	ELECTRO 1.0UF 50WV		
C379			CK45FB1H471K	CERAMIC 470PF K		
C380			CE04KW1H4R7M	ELECTRO 4.7UF 50WV		

L : Scandinavia K : USA P : Canada R : Mexico C : China I : Malaysia
Y : PX(Far East,Hawaii) T : England E : Europe G : Germany V : China(Shanghai)
Y : AAFES(Europe) X : Australia Q : Russia H : Korea M : Other Areas Δ indicates safety critical components .

* New Parts

Parts without **Parts No.** are not supplied.
Les articles non mentionnés dans le **Parts No.** ne sont pas fournis.
Teile ohne **Parts No.** werden nicht geliefert.



Ref. No	Add-ress	New Parts	Parts No.	Description	Desti-nation	Re-marks
C384-386			CK45FB1H471K	CERAMIC 470PF K		
C391,392			CC45FSL1H101J	CERAMIC 100PF J	579	
C401			CE04KW1A101M	ELECTRO 100UF 10WV		
C403,404			CE04KW2A100M	ELECTRO 10UF 100WV		
C405			CC45FSL1H470J	CERAMIC 47PF J		
C406,407			CE04KW1H2R2M	ELECTRO 2.2UF 50WV		
C408,409			CK45FB1H471K	CERAMIC 470PF K		
C410,411			CC45FSL1H331J	CERAMIC 330PF J		
C412,413			CE04KW1A101M	ELECTRO 100UF 10WV		
C416,417			CC45FSL1H100D	CERAMIC 10PF D		
C424,425			CK45FF1H472Z	CERAMIC 4700PF Z		
C426-429			C91-1573-05	MP-C 0.10UF J	679	
C430			CK45FF1H472Z	CERAMIC 4700PF Z	679	
C431			CC45FSL1H100D	CERAMIC 10PF D	679	
C433			CE04KW1A101M	ELECTRO 100UF 10WV	679	
C434			CC45FSL1H331J	CERAMIC 330PF J	679	
C435			CK45FB1H471K	CERAMIC 470PF K	679	
C436			CE04KW1H2R2M	ELECTRO 2.2UF 50WV	679	
C437,438			C91-1573-05	MP-C 0.10UF J	679	
C439-443			CK45FB1H222K	CERAMIC 2200PF K		
C444			CC45FSL1H221J	CERAMIC 220PF J	45789	
C445			CC45FSL1H560J	CERAMIC 56PF J		
C446			CK45FB1H222K	CERAMIC 2200PF K	679	
C638-642			CC45FSL1H470J	CERAMIC 47PF J		
C643-645			CE04KW1E470M	ELECTRO 47UF 25WV		
C648			CE04RW1C100M	ELECTRO 10UF 16WV		
C652			CE04RW1C100M	ELECTRO 10UF 16WV		
C701			CC45FSL1H101J	CERAMIC 100PF J	579	
C702			CE04KW1H2R2M	ELECTRO 2.2UF 50WV	79	
C702			CE04KW1H4R7M	ELECTRO 4.7UF 50WV	Y4Y5X5	
C703			CC45FSL1H101J	CERAMIC 100PF J	579	
C826,827			CK45FB1H471K	CERAMIC 470PF K		
CN101			E40-8481-05	FLAT CABLE CONNECTOR (15P)		
CN102			E40-8502-05	FLAT CABLE CONNECTOR (17P)		
CN103			E40-8481-05	FLAT CABLE CONNECTOR (15P)		
CN201			E40-8484-05	FLAT CABLE CONNECTOR (21P)	468	
J201			E40-8601-05	FLAT CABLE CONNECTOR (25P)	579	
J202			E63-1321-05	PIN JACK		
J203			E63-1301-05	PIN JACK	689	
J203			E63-1301-05	PIN JACK	457	
J204			E63-1322-05	PIN JACK	457	
Δ J205			E03-0396-05	AC OUTLET	Y1Y2Y3	
Δ J205			E03-0396-05	AC OUTLET	Y4Y5	
Δ J205			E03-0396-05	AC OUTLET	89	
Δ J205			E03-0398-05	AC OUTLET	E1E2E3	
Δ J205			E03-0398-05	AC OUTLET	E4E5	
Δ J206			E03-0325-05	AC OUTLET	E6E7	
Δ J206			E03-0325-05	AC OUTLET	X2X3X5	
Δ J401			E70-0156-05	LOCK TERMINAL BOARD	X7	
J402			E70-0175-05	LOCK TERMINAL BOARD	458	
J403			E70-0154-05	LOCK TERMINAL BOARD	679	

L : Scandinavia K : USA P : Canada R : Mexico C : China I : Malaysia
Y : PX(Far East,Hawaii) T : England E : Europe G : Germany V : China(Shanghai)
Y : AAFES(Europe) X : Australia Q : Russia H : Korea M : Other Areas Δ indicates safety critical components .

KRF-V4080D/V5080D/V5580D-S/V6080D/MR-804-S/806
PARTS LIST

* New Parts

Parts without **Parts No.** are not supplied.Les articles non mentionnés dans le **Parts No.** ne sont pas fournis.Teile ohne **Parts No.** werden nicht geliefert.

13

Ref. No	Add-ress	New Parts	Parts No.	Description	Desti-nation	Re-marks
J404			E63-1146-05	PIN JACK	45789	
J603			E63-1291-05	PIN JACK		
J604			E63-1314-05	PIN JACK		
J801			E11-0271-05	PHONE JACK (METAL SLEEVE)		
△ F101			F05-3121-05	FUSE (SEMKO) (250V T3.15AL)	4567	
△ F101			F50-0077-05	FUSE(5X20)	89	
△ F102			F06-1022-05	FUSE (SEMKO) (250V T1AL)	4567	
△ F103			F05-3121-05	FUSE (SEMKO) (250V T3.15AL)	Y1Y2Y3	
△ F103			F05-3121-05	FUSE (SEMKO) (250V T3.15AL)	Y4Y5	
CN108,109			J13-0075-05	FUSE CLIP	4567	
CN110,111			J13-0075-05	FUSE CLIP		
CN116,117			J13-0075-05	FUSE CLIP	Y1Y2Y3	
CN116,117			J13-0075-05	FUSE CLIP	Y4Y5	
L301-303			L39-1373-05	PHASE COMPENSATION COIL		
L401,402			L39-1373-05	PHASE COMPENSATION COIL		
L403			L39-1373-05	PHASE COMPENSATION COIL	678	
△ T101			L07-2758-05	POWER TRANSFORMER	E3X3	
△ T101			L07-2758-05	POWER TRANSFORMER	E4E5X5	
△ T101			L07-2758-05	POWER TRANSFORMER	X2E1E2	
△ T101			L07-2758-05	POWER TRANSFORMER	489	
△ T101			L07-2761-05	POWER TRANSFORMER	E3X3	
△ T101			L07-2761-05	POWER TRANSFORMER	E4E5X5	
△ T101			L07-2761-05	POWER TRANSFORMER	X2E1E2	
△ T101			L07-2761-05	POWER TRANSFORMER	489	
△ T101			L07-2805-05	POWER TRANSFORMER	Y1Y2Y3	
△ T101			L07-2805-05	POWER TRANSFORMER	Y4Y5	
X101			L77-2002-05	CRYSTAL RESONATOR(4.332MHZ)	E1E2E3	
X101			L77-2002-05	CRYSTAL RESONATOR(4.332MHZ)	E4E5	
X101			L77-2002-05	CRYSTAL RESONATOR(4.332MHZ)	E6E7	
△ R123			RD14NB2E1R0J	RD 1 J 1/4W		
R124			RS14KB3A221J	FL-PROOF RS 220 J 1W	Y1Y2Y3	
R124			RS14KB3A221J	FL-PROOF RS 220 J 1W	Y4Y5	
R124			RS14KB3A221J	FL-PROOF RS 220 J 1W	89	
R125			RD14NB2E270J	RD 27 J 1/4W		
△ R126			RD14NB2E101J	RD 100 J 1/4W		
R127			RD14NB2E822J	RD 8.2K J 1/4W		
△ R132			R92-1844-05	CARBON 3.3M J 2W	89	
△ R141,142			RD14NB2E1R0J	RD 1 J 1/4W		
△ R262			RD14BB2C132J	RD 1.3K J 1/6W		
R316,317			RS14KB3A472J	FL-PROOF RS 4.7K J 1W		
R334,335			RD14NB2E4R7J	RD 4.7 J 1/4W		
R338-341			RS14KB3DR22J	FL-PROOF RS 0.22 J 2W		
R342,343			RS14KB3D4R7J	FL-PROOF RS 4.7 J 2W		
R345			RS14KB3D4R7J	FL-PROOF RS 4.7 J 2W		
R347			RD14NB2E4R7J	RD 4.7 J 1/4W		
R348,349			RS14KB3DR22J	FL-PROOF RS 0.22 J 2W		
R365			RD14NB2E561J	RD 560 J 1/4W		
R410			RD14NB2E103J	RD 10K J 1/4W		
R411			RD14NB2E101J	RD 100 J 1/4W		
R414			RD14NB2E101J	RD 100 J 1/4W		
R415			RD14NB2E103J	RD 10K J 1/4W		
R436			RD14NB2E4R7J	RD 4.7 J 1/4W		
R438,439			RS14KB3D391J	FL-PROOF RS 390 J 2W		
R452,453			RS14KB3A472J	FL-PROOF RS 4.7K J 1W		

L : Scandinavia K : USA P : Canada R : Mexico C : China I : Malaysia

Y : PX(Far East,Hawaii) T : England E : Europe G : Germany V : China(Shanghai)

Y : AAFES(Europe) X : Australia Q : Russia H : Korea M : Other Areas △ indicates safety critical components .

* New Parts

Parts without **Parts No.** are not supplied.Les articles non mentionnés dans le **Parts No.** ne sont pas fournis.Teile ohne **Parts No.** werden nicht geliefert.

14

Ref. No	Add-ress	New Parts	Parts No.	Description	Desti-nation	Re-marks
R460-463			RS14KB3DR22J	FL-PROOF RS 0.22 J 2W		
R466,467			RD14NB2E4R7J	RD 4.7 J 1/4W		
R468,469			RS14KB3D4R7J	FL-PROOF RS 4.7 J 2W		
R473,474			RS14KB3DR22J	FL-PROOF RS 0.22 J 2W	679	
R475			RD14NB2E4R7J	RD 4.7 J 1/4W	679	
R476			RS14KB3D4R7J	FL-PROOF RS 4.7 J 2W	679	
R478-480			RS14KB3A221J	FL-PROOF RS 220 J 1W		
R995,996			RS14KB3D332J	FL-PROOF RS 3.3K J 2W		
△ K101			S76-0099-05	MAGNETIC RELAY	89	
△ K101			S76-0102-05	MAGNETIC RELAY	4567	
△ K401-403			S76-0097-05	MAGNETIC RELAY		
△ S101			S62.1.5	SLIDE SWITCH	Y1Y2Y3	
△ S101			S62.1.5	SLIDE SWITCH	Y4Y5	
△ S102			S68-0107-05	PUSH SWITCH	4567	
D113			RB441Q-40	DIODE		
△ D114,115			HSS104A	DIODE		
△ D114,115			1SS133	DIODE		
D116			HSS104A	DIODE		
D116			1SS133	DIODE		
△ D117			S1ZB20(4101)	DIODE		
D118			HZS16N(B2)	ZENER DIODE		
D118			MTZJ16(B)	ZENER DIODE		
D119			HZS15N(B2)	ZENER DIODE		
D119			MTZJ15(B)	ZENER DIODE		
△ D120			D2SBA20F03	DIODE		
△ D121,122			D5SBA20F03	DIODE		
D123,124			HSS104A	DIODE	Y1Y2Y3	
D123,124			HSS104A	DIODE	Y4Y5	
D123,124			1SS133	DIODE	Y1Y2Y3	
D123,124			1SS133	DIODE	Y4Y5	
D201			HZS6.8N(B2)	ZENER DIODE		
D201			MTZJ6.8(B)	ZENER DIODE		
D202			HZS5.1N(B2)	ZENER DIODE		
D202			MTZJ5.1(B)	ZENER DIODE		
D203			HZS6.8N(B2)	ZENER DIODE		
D203			MTZJ6.8(B)	ZENER DIODE		
D215			HSS104A	DIODE	Y1Y2Y3	
D215			HSS104A	DIODE	Y4Y5	
D215			HSS104A	DIODE	89	
D215			1SS133	DIODE	Y1Y2Y3	
D215			1SS133	DIODE	Y4Y5	
D215			1SS133	DIODE	89	
D301,302			HZS15N(B2)	ZENER DIODE		
D301,302			MTZJ15(B)	ZENER DIODE		
D303,304			HSS104A	DIODE		
D303,304			1SS133	DIODE		
D305,306			HZS10N(B2)	ZENER DIODE	4567	
D305,306			HZS11N(B2)	ZENER DIODE	89	
D305,306			MTZJ10(B)	ZENER DIODE	4567	
D305,306			MTZJ11(B)	ZENER DIODE	89	
D307			HZS3.9N(B2)	ZENER DIODE		
D307			MTZJ3.9(B)	ZENER DIODE		
D308-310			HSS104A	DIODE		
D308-310			1SS133	DIODE		

L : Scandinavia K : USA P : Canada R : Mexico C : China I : Malaysia

Y : PX(Far East,Hawaii) T : England E : Europe G : Germany V : China(Shanghai)

Y : AAFES(Europe) X : Australia Q : Russia H : Korea M : Other Areas △ indicates safety critical components .

* New Parts

Parts without **Parts No.** are not supplied.
Les articles non mentionnés dans le **Parts No.** ne sont pas fournis.
Teile ohne **Parts No.** werden nicht geliefert.

15

Ref. No	Address	New Parts	Parts No.	Description	Destination	Remarks
D311,312			HZS3.9N(B2)	ZENER DIODE		
D311,312			MTZJ3.9(B)	ZENER DIODE		
D313			HSS104A	DIODE		
D313			1SS133	DIODE		
D314			HZS3.9N(B2)	ZENER DIODE		
D314			MTZJ3.9(B)	ZENER DIODE		
D315			HSS104A	DIODE		
D315			1SS133	DIODE		
D316			HZS3.9N(B2)	ZENER DIODE		
D316			MTZJ3.9(B)	ZENER DIODE		
D317,318			HSS104A	DIODE		
D317,318			1SS133	DIODE		
D319			HZS11N(B2)	ZENER DIODE	E1E2E3	
D319			HZS11N(B2)	ZENER DIODE	E4E5	
D319			HZS11N(B2)	ZENER DIODE	E6E7	
D319			MTZJ11(B)	ZENER DIODE	E1E2E3	
D319			MTZJ11(B)	ZENER DIODE	E4E5	
D319			MTZJ11(B)	ZENER DIODE	E6E7	
D319,320			HZS15N(B2)	ZENER DIODE	89	
D319,320			HZS16N(B2)	ZENER DIODE	Y1Y2Y3	
D319,320			HZS16N(B2)	ZENER DIODE	Y3X5X7	
D319,320			HZS16N(B2)	ZENER DIODE	Y4Y5X2	
D319,320			MTZJ15(B)	ZENER DIODE	89	
D319,320			MTZJ16(B)	ZENER DIODE	Y1Y2Y3	
D319,320			MTZJ16(B)	ZENER DIODE	Y3X5X7	
D319,320			MTZJ16(B)	ZENER DIODE	Y4Y5X2	
D320			HZS13N(B2)	ZENER DIODE	E1E2E3	
D320			HZS13N(B2)	ZENER DIODE	E4E5	
D320			HZS13N(B2)	ZENER DIODE	E6E7	
D320			MTZJ13(B)	ZENER DIODE	E1E2E3	
D320			MTZJ13(B)	ZENER DIODE	E4E5	
D320			MTZJ13(B)	ZENER DIODE	E6E7	
D323			HSS104A	DIODE		
D323			1SS133	DIODE		
D401,402			HZS15N(B2)	ZENER DIODE		
D401,402			MTZJ15(B)	ZENER DIODE		
D403,404			HSS104A	DIODE		
D403,404			1SS133	DIODE		
D406-408			HSS104A	DIODE		
D406-408			1SS133	DIODE		
D602,603			HZS5.6N(B2)	ZENER DIODE		
D602,603			MTZJ5.6(B)	ZENER DIODE		
D999			HSS104A	DIODE		
D999			1SS133	DIODE		
IC101			BU1923	ANALOGUE IC	E1E2E3	
IC101			BU1923	ANALOGUE IC	E4E5	
IC101			BU1923	ANALOGUE IC	E6E7	
IC105			BA05T	ANALOGUE IC		
IC106			KIA7812API	ANALOGUE IC		
IC107			KIA7912PI	ANALOGUE IC		
IC201			NJM4580L-D	ANALOGUE IC	E1E2E4	
IC201			NJM4580L-D	ANALOGUE IC	E5E6E7	
IC202			M61516FP	ANALOGUE IC		
IC206			NJM4565D	ANALOGUE IC		
IC301			STK413-020A	HYBRID IC		

L : Scandinavia K : USA P : Canada R : Mexico C : China I : Malaysia
Y : PX(Far East,Hawaii) T : England E : Europe G : Germany V : China(Shanghai)
Y : AAFES(Europe) X : Australia Q : Russia H : Korea M : Other Areas Δ indicates safety critical components.

* New Parts

Parts without **Parts No.** are not supplied.
Les articles non mentionnés dans le **Parts No.** ne sont pas fournis.
Teile ohne **Parts No.** werden nicht geliefert.

16

Ref. No	Address	New Parts	Parts No.	Description	Destination	Remarks
Δ IC301			STK413-220A	HYBRID IC		
Δ IC401			STK412-020A	HYBRID IC	458	
Δ IC401			STK412-220A	HYBRID IC	458	
Δ IC401			STK413-020A	HYBRID IC	769	
Δ IC401			STK413-220A	HYBRID IC	769	
IC607			NJM2279D	ANALOGUE IC		
Q113			2SB1640	TRANSISTOR		
Q114			2SC1740S(Q,R)	TRANSISTOR		
Q114			2SC2785(F,E)	TRANSISTOR		
Δ Q201			2SC1845(F,E)	TRANSISTOR		
Δ Q203			2SA992(F,E)	TRANSISTOR		
Q301-306			2SC2878(B)	TRANSISTOR		
Q307,308			2SA992(F,E)	TRANSISTOR		
Q309-315			2SC1845(F,E)	TRANSISTOR		
Q316			2SA992(F,E)	TRANSISTOR		
Q317,318			2SC2878(B)	TRANSISTOR		
Q319			2SA992(F,E)	TRANSISTOR		
Q401			2SC1845(F,E)	TRANSISTOR		
Q402			2SA1535A	TRANSISTOR		
Q403			2SC3944A	TRANSISTOR		
Q404			2SC1845(F,E)	TRANSISTOR		
Q405			2SA992(F,E)	TRANSISTOR		
Q406			2SB1640	TRANSISTOR		
Q407,408			2SC1845(F,E)	TRANSISTOR		
Q409			2SC1845(F,E)	TRANSISTOR	679	
Q410,411			DTC113ZSA	DIGITAL TRANSISTOR		
Q410,411			UN4219	DIGITAL TRANSISTOR		
Q412			2SC1740S(Q,R)	TRANSISTOR		
Q412			2SC2785(F,E)	TRANSISTOR		
Q701			2SC2878(B)	TRANSISTOR	79	
Q800			2SC1845(F,E)	TRANSISTOR	79	
Q801,802			2SA992(F,E)	TRANSISTOR	79	
Q803			DTC113ZSA	DIGITAL TRANSISTOR	79	
Q803			UN4219	DIGITAL TRANSISTOR	79	
DISPLAY (X14-7770-10/X14-7800-10)						
D805-807			B30-2545-05	LED(RED3(160))		
D808			B30-2597-05	LED(RED HI-BRIGHT)		
C801			CE04RW1H330M	ELECTRO	33UF	50WV
C802,803			CE04RW1H010M	ELECTRO	1.0UF	50WV
C804			CE04LW1H470M	ELECTRO	47UF	50WV
C805			CE04RW1A101M	ELECTRO	100UF	10WV
C806			CE04RW1E470M	ELECTRO	47UF	25WV
C807			CE04RW1H100M	ELECTRO	10UF	50WV
C809			CE04RW1H010M	ELECTRO	1.0UF	50WV
C810			C90-1826-05	BACKUP-C	0.047F	5.5WV
C811			CE04RW1A101M	ELECTRO	100UF	10WV
C812			CE04HW1H100M	NP-ELEC	10UF	50WV
C813			CK45FF1H103Z	CERAMIC	0.010UF	Z
C814			CC45FSL1H101J	CERAMIC	100PF	J
C815,816			CK45FF1H103Z	CERAMIC	0.010UF	Z
C817			CC45FSL1H101J	CERAMIC	100PF	J
C818,819			CK45FF1H103Z	CERAMIC	0.010UF	Z
C820,821			C91-0769-05	CERAMIC	0.010UF	K
C822-824			CK45FF1H103Z	CERAMIC	0.010UF	Z

L : Scandinavia K : USA P : Canada R : Mexico C : China I : Malaysia
Y : PX(Far East,Hawaii) T : England E : Europe G : Germany V : China(Shanghai)
Y : AAFES(Europe) X : Australia Q : Russia H : Korea M : Other Areas Δ indicates safety critical components.

KRF-V4080D/V5080D/V5580D-S/V6080D/MR-804-S/806
PARTS LIST

* New Parts
Parts without **Parts No.** are not supplied.
Les articles non mentionnés dans le **Parts No.** ne sont pas fournis.
Teile ohne **Parts No.** werden nicht geliefert.

17

Ref. No	Add-ress	New Parts	Parts No.	Description	Desti-nation	Re-marks
C825			CE04RW1H010M	ELECTRO 1.0UF 50WV		
C827			CE04RW1H100M	ELECTRO 10UF 50WV		
C828-833			CK45FF1H103Z	CERAMIC 0.010UF Z		
C834			CQ93FMG1H103J	MYLAR 0.010UF J		
C835			CF92FV1H104J	MF-C 0.10UF J		
C836-839			C91-0745-05	CERAMIC 100PF K		
C840			CQ93FMG1H104J	MYLAR 0.10UF J		
C841			C91-0745-05	CERAMIC 100PF K		
C843			CE04KW1H2R2M	ELECTRO 2.2UF 50WV	Y1Y2Y3	
C843			CE04KW1H2R2M	ELECTRO 2.2UF 50WV	Y4Y5	
C844,845			CK45FF1H103Z	CERAMIC 0.010UF Z	Y1Y2Y3	
C844,845			CK45FF1H103Z	CERAMIC 0.010UF Z	Y4Y5	
C846			CQ93FMG1H103J	MYLAR 0.010UF J		
C847,848			C91-0745-05	CERAMIC 100PF K		
C849			CC45FSL1H100D	CERAMIC 10PF D		
C850			CC45FSL1H101J	CERAMIC 100PF J		
C851			C91-0745-05	CERAMIC 100PF K		
C852			CK45FB1H102K	CERAMIC 1000PF K		
CN801			E40-8502-05	FLAT CABLE CONNECTOR (17P)		
CN802			E40-8501-05	FLAT CABLE CONNECTOR (15P)		
CN803			E40-8503-05	FLAT CABLE CONNECTOR (19P)		
-		*	J19-6286-03	HOLDER		
X800			L78-0747-05	RESONATOR (4MHZ)		
X801			L78-0725-05	RESONATOR (8.38MHZ)		
CP801			R90-0500-05	MULTI-COMP 100KX6 J 1/4W		
CP802			R90-0855-05	MULTI-COMP 100KX5 J		
CP803			R90-0493-05	MULTI-COMP 100KX9 J 1/6W		
R849			RD14NB2E2R2J	RD 2.2 J 1/4W		
S801-812			S70-0031-05	TACT SWITCH		
S801-812			S70-0086-05	TACT SWITCH		
S813,814			T99-0666-05	ROTARY ENCODER		
S815			T99-0664-05	ROTARY ENCODER		
D801			MTZJ6.2(B)	ZENER DIODE		
D801			RD6.2ES(B)	ZENER DIODE		
D802-804			HSS104A	DIODE		
D802-804			1SS133	DIODE	E3X3	
D809			HSS104A	DIODE		
D809			HSS104A	DIODE	E4E5X5	
D809			HSS104A	DIODE	X2E1E2	
D809			HSS104A	DIODE	4	
D809			1SS133	DIODE	E3X3	
D809			1SS133	DIODE	E4E5X5	
D809			1SS133	DIODE	X2E1E2	
D809			1SS133	DIODE	4	
D809-811			HSS104A	DIODE	Y1Y2Y3	
D809-811			HSS104A	DIODE	Y4Y5	
D809-811			HSS104A	DIODE	89	
D809-811			1SS133	DIODE	Y1Y2Y3	
D809-811			1SS133	DIODE	Y4Y5	
D809-811			1SS133	DIODE	89	
D811			HSS104A	DIODE	E3X3	
D811			HSS104A	DIODE	E4E5X5	

L : Scandinavia K : USA P : Canada R : Mexico C : China I : Malaysia
Y : PX(Far East,Hawaii) T : England E : Europe G : Germany V : China(Shanghai)
Y : AAFES(Europe) X : Australia Q : Russia H : Korea M : Other Areas Δ indicates safety critical components.

* New Parts
Parts without **Parts No.** are not supplied.
Les articles non mentionnés dans le **Parts No.** ne sont pas fournis.
Teile ohne **Parts No.** werden nicht geliefert.

18

Ref. No	Add-ress	New Parts	Parts No.	Description	Desti-nation	Re-marks
D811			HSS104A	DIODE	X2E1E2	
D811			HSS104A	DIODE	4	
D811			1SS133	DIODE	E3X3	
D811			1SS133	DIODE	E4E5X5	
D811			1SS133	DIODE	X2E1E2	
Δ D811			1SS133	DIODE	4	
D812,813			RB441Q-40	DIODE		
D814			HSS104A	DIODE	Y1Y2Y3	
D814			1SS133	DIODE		
D816			HSS104A	DIODE		
D816			HSS104A	DIODE	Y4Y5	
D816			1SS133	DIODE	Y1Y2Y3	
D816			1SS133	DIODE	Y4Y5	
D819-828			HSS104A	DIODE		
D819-828			1SS133	DIODE		
ED801		*	11-MT-143GNK	FLUORESCENT INDICATOR TUBE	579	
ED801			11MT129GNK	FLUORESCENT INDICATOR TUBE	468	
IC801			MN12510F	MOS-IC		
IC801			MN12510FNOPB	MOS-IC		
IC802			S-80840CNY	ANALOGUE IC		
IC803			XC6202P502TH	MOS-IC		
IC804			MN101C49KLE	MI-COM IC	468	
IC804		*	MN101C49KLG	MICROCONTROLLER IC	579	
IC806			S-80840CNY	ANALOGUE IC	Y1Y2Y3	
IC806			S-80840CNY	ANALOGUE IC	Y4Y5	
Q802			2SC1740S(Q,R)	TRANSISTOR		
Q802			2SC2785(F,E)	TRANSISTOR		
Q803			2SA1175(F,E)	TRANSISTOR		
Q803			2SA933AS(Q,R)	TRANSISTOR		
Q804-807			2SC1740S(Q,R)	TRANSISTOR		
Q804-807			2SC2785(F,E)	TRANSISTOR		
A801			W02-2759-05	ELECTRIC CIRCUIT MODULE		
SUB (X25-6670-10)						
C101-107			CC45FSL1H100D	CERAMIC 10PF D		
C108,109			CC45FSL1H820J	CERAMIC 82PF J		
C110-115			CE04LW1H100M	ELECTRO 10UF 50WV		
C116			CK45FF1H103Z	CERAMIC 0.010UF Z		
C117			CE04LW1H100M	ELECTRO 10UF 50WV		
C118			CE04LW1A471M	ELECTRO 470UF 10WV		
C119			CK45FF1H103Z	CERAMIC 0.010UF Z		
C120			CE04LW1H100M	ELECTRO 10UF 50WV		
C121			CE04LW1A471M	ELECTRO 470UF 10WV		
C122			CE04LW1V330M	ELECTRO 33UF 35WV		
C123			CE04LW1H100M	ELECTRO 10UF 50WV		
C124			CE04LW1A471M	ELECTRO 470UF 10WV		
C125			CQ93FMG1H104J	MYLAR 0.10UF J		
C126			CE04LW1E470M	ELECTRO 47UF 25WV		
C127-129			CK45FF1H103Z	CERAMIC 0.010UF Z		
C130-132			CQ93FMG1H104J	MYLAR 0.10UF J		
C133			CE04LW1E470M	ELECTRO 47UF 25WV		
C134-141			CK45FF1H103Z	CERAMIC 0.010UF Z		
C511			CE04LW1H100M	ELECTRO 10UF 50WV		
CN501			E40-3249-05	PIN ASSY (5P)		

L : Scandinavia K : USA P : Canada R : Mexico C : China I : Malaysia
Y : PX(Far East,Hawaii) T : England E : Europe G : Germany V : China(Shanghai)
Y : AAFES(Europe) X : Australia Q : Russia H : Korea M : Other Areas Δ indicates safety critical components.

* New Parts
 Parts without **Parts No.** are not supplied.
 Les articles non mentionnés dans le **Parts No.** ne sont pas fournis.
 Teile ohne **Parts No.** werden nicht geliefert.



Ref. No	Add-ress	New Parts	Parts No.	Description	Desti-nation	Re-marks
0J101		*	E63-1325-05	PIN ASSY		
J102		*	E63-1326-05	PIN ASSY		
△ R517			RD14NB2E470J	RD 47 J 1/4W		
D501			HZS5.6N(B2)	ZENER DIODE		
D501			MTZJ5.6(B)	ZENER DIODE		
IC101		*	NJM2584D	ANALOGUE IC		
IC102		*	NJM2580D	ANALOGUE IC		
△ Q501			2SC3940A(R,S)	TRANSISTOR		
Q503,504			DTC124ESA	DIGITAL TRANSISTOR		
Q503,504			UN4212	DIGITAL TRANSISTOR		

KRF-V4080D/V5080D/V5580D-S/V6080D/MR-804-S/806
PARTS LIST

L: Scandinavia **K**: USA **P**: Canada **R**: Mexico **C**: China **I**: Malaysia
Y: PX(Far East,Hawaii) **T**: England **E**: Europe **G**: Germany **V**: China(Shanghai)
Y: AAFES(Europe) **X**: Australia **Q**: Russia **H**: Korea **M**: Other Areas △ indicates safety critical components.

KRF-V4080D/V5080D/V5580D-S/V6080D/VR-804-S/806

PARTS LIST

Model Name	Model #		ABB.	Surround	Audio	Display	Sub
VR-806	Y05-4890-10	K	K1	X08-3300-10	X09-6850-10	X14-7770-10	X25-6670-10
VR-806	Y05-4891-01	P	P1	X08-3300-10	X09-6850-10	X14-7770-10	X25-6670-10
VR-806-S	Y05-4890-11	K	K2	X08-3300-10	X09-6850-10	X14-7770-10	X25-6670-10
VR-806-S	Y05-4891-02	P	P2	X08-3300-10	X09-6850-10	X14-7770-10	X25-6670-10
KRF-V6080D	Y05-4892-71	E	E1	X08-3300-11	X09-6852-71	X14-7772-71	X25-6670-10
KRF-V6080D	Y05-4892-91	Y	Y1	X08-3302-91	X09-6852-91	X14-7772-91	X25-6670-10
KRF-V6080D-S	Y05-4892-72	E	E2	X08-3300-11	X09-6852-71	X14-7772-71	X25-6670-10
KRF-V6080D-S	Y05-4890-71	X	X2	X08-3300-11	X09-6850-71	X14-7770-71	X25-6670-10
KRF-V6080D-S	Y05-4892-92	Y	Y2	X08-3302-91	X09-6852-91	X14-7772-91	X25-6670-10
KRF-V5580D-S	Y05-4932-70	E	E3	X08-3320-10	X09-6882-71	X14-7802-72	-
KRF-V5580D-S	Y05-4930-71	X	X3	X08-3320-10	X09-6880-71	X14-7800-72	-
KRF-V5580D-S	Y05-4932-91	Y	Y3	X08-3320-21	X09-6882-91	X14-7800-22	-
KRF-V5080D	Y05-4902-70	E	E4	X08-3300-10	X09-6852-72	X14-7772-72	-
KRF-V5080D	Y05-4902-91	Y	Y4	X08-3302-92	X09-6852-92	X14-7772-92	X25-6670-10
KRF-V5080D-S	Y05-4902-71	E	E5	X08-3300-10	X09-6852-72	X14-7772-72	-
KRF-V5080D-S	Y05-4900-71	X	X5	X08-3300-10	X09-6850-72	X14-7770-72	-
KRF-V5080D-S	Y05-4902-92	Y	Y5	X08-3302-92	X09-6852-92	X14-7772-92	X25-6670-10
VR-804-S	Y05-4920-10	K	K3	X08-3320-10	X09-6870-10	X14-7800-10	-
VR-804-S	Y05-4921-01	P	P3	X08-3320-10	X09-6870-10	X14-7800-10	-
KRF-V4080D	Y05-4922-71	E	E6	X08-3320-10	X09-6872-71	X14-7802-71	-
KRF-4080D-S	Y05-4922-72	E	E7	X08-3320-10	X09-6872-71	X14-7802-71	-
KRF-4080D-S	Y05-4920-71	X	X7	X08-3320-10	X09-6870-71	X14-7800-71	-

HOW TO READ THE PARTS LIST

ABBREVIATION OF MODEL AND MASS PRODUCTION'S DESTINATIONS

MODEL	ABB.	Australia	Canada	China	England	Europe	Germany	Korea	Malaysia
		X	P	-	-	E	-	-	-
VR-806	9	-	P1	-	-	-	-	-	-
VR-806-S	9	-	P2	-	-	-	-	-	-
VR-804-S	8	-	P3	-	-	-	-	-	-
KRF-V6080D	7	-	-	-	-	E1	-	-	-
KRF-V6080D-S	7	X2	-	-	-	E2	-	-	-
KRF-V5580D-S	6	X3	-	-	-	E3	-	-	-
KRF-V5080D	5	-	-	-	-	E4	-	-	-
KRF-V5080D-S	5	X5	-	-	-	E5	-	-	-
KRF-V4080D	4	-	-	-	-	E6	-	-	-
KRF-V4080D-S	4	X7	-	-	-	E7	-	-	-
MODEL	ABB.	Mexico	PX/AAFES	Russia	Scandinavia	Shanghai	USA	Other area	
		-	Y	-	-	-	K	-	
VR-806	9	-	-	-	-	-	K1	-	-
VR-806-S	9	-	-	-	-	-	K2	-	-
VR-804-S	8	-	-	-	-	-	K3	-	-
KRF-V6080D	7	-	Y1	-	-	-	-	-	-
KRF-V6080D-S	7	-	Y2	-	-	-	-	-	-
KRF-V5580D-S	6	-	Y3	-	-	-	-	-	-
KRF-V5080D	5	-	Y4	-	-	-	-	-	-
KRF-V5080D-S	5	-	Y5	-	-	-	-	-	-
KRF-V4080D	4	-	-	-	-	-	-	-	-
KRF-V4080D-S	4	-	-	-	-	-	-	-	-

KRF-V4080D/V5080D/V5580D-S/V6080D/VR-804-S/806

SPECIFICATIONS

KRF-V4080D/KRF-V5580D

AUDIO section (For Europe)

Rated power output during STEREO operation	
DIN/IEC (63 Hz ~ 12.5 kHz, 0.7% T.H.D., at 6 Ω)	100 W + 100 W
Effective power output during SURROUND operation	
FRONT	
(1 kHz, 0.7% T.H.D. at 6 Ω one channel driven)	100 W + 100 W
(1 kHz, 10% T.H.D. at 6 Ω one channel driven)	120 W + 120 W
CENTER	
(1 kHz, 0.7% T.H.D. at 6 Ω one channel driven)	100 W
(1 kHz, 10% T.H.D. at 6 Ω one channel driven)	120 W
SURROUND	
(1 kHz, 0.7% T.H.D. at 6 Ω one channel driven)	100 W + 100 W
(1 kHz, 10% T.H.D. at 6 Ω one channel driven)	120 W + 120 W
SUBWOOFER (KRF-V5580)	
(80Hz, 0.7% T.H.D. at 6 Ω one channel driven)	100 W
(80Hz, 10% T.H.D. at 6 Ω one channel driven)	120 W
Total harmonic distortion	0.05% (1kHz, 50 W, 6 Ω)
Frequency response (IHF'66)	
CD/DVD	20 Hz ~ 70 kHz, 0 dB, -3.0 dB
Signal to noise ratio (IHF'66)	
PHONO (MM) (KRF-V4080D)	74 dB
CD/DVD, AUX, TAPE, VIDEO 1, VIDEO 2	95 dB
Input sensitivity / impedance	
PHONO (MM) (KRF-V4080D)	7.5 mV / 27 kΩ
CD/DVD	550 mV / 47 kΩ
DVD/6CH INPUT (KRF-V4080D)	550 mV / 15 kΩ
Output level / impedance	
TAPE REC.	550 mV / 1 kΩ
PRE OUT (SUBWOOFER) (KRF-V4080D)	1.5 V / 2.2 kΩ
Tone control	
BASS	±10 dB (at 100 Hz)
TREBLE	±10 dB (at 10 kHz)
Loudness control	
VOLUME at -30dB level	+8 dB (at 100 Hz)

AUDIO section (For other countries)

Rated power output during STEREO operation

100 watts per channel minimum RMS, both channels driven, at 8 Ω from 40 Hz to 20 kHz with no more than 0.7% total harmonic distortion. (FTC)

Effective power output during SURROUND operation	
FRONT	
(1 kHz, 0.7% T.H.D. at 8 Ω one channel driven)	100 W + 100 W
(1 kHz, 10% T.H.D. at 8 Ω one channel driven)	120 W + 120 W
CENTER	
(1 kHz, 0.7% T.H.D. at 8 Ω one channel driven)	100 W
(1 kHz, 10% T.H.D. at 8 Ω one channel driven)	120 W
SURROUND	
(1 kHz, 0.7% T.H.D. at 8 Ω one channel driven)	100 W + 100 W
(1 kHz, 10% T.H.D. at 8 Ω one channel driven)	120 W + 120 W
SUBWOOFER (KRF-V5580D)	
(80 Hz, 0.7% T.H.D. at 8 Ω one channel driven)	100 W
(80 Hz, 10% T.H.D. at 8 Ω one channel driven)	120 W
Total harmonic distortion	0.05% (1 kHz, 50 W, 8 Ω)
Frequency response	
CD/DVD	20 Hz ~ 70 kHz, 0 dB, -3.0 dB
Signal to noise ratio (IHF'66)	
CD/DVD, AUX, TAPE, VIDEO1, VIDEO2	95 dB
Input sensitivity / impedance	
CD/DVD	550 mV / 47 kΩ
DVD/6CH INPUT (KRF-V4080D)	550 mV / 15 kΩ
Output level / impedance	
TAPE REC.	550 mV / 1 kΩ
PRE OUT (SUBWOOFER) (KRF-V4080D)	1.5 V / 2.2 kΩ
Tone control	
BASS	±10 dB (at 100 Hz)
TREBLE	±10 dB (at 10 kHz)
Loudness control	
VOLUME at -30dB level	+8 dB (at 100 Hz)

DIGITAL AUDIO section

Sampling frequency	32 kHz, 44.1 kHz, 48 kHz, 96kHz
Input level / impedance / wave length	
Optical	(-15 dBm ~ -21 dBm), 660 nm ±30nm
Coaxial	0.5 Vp-p / 75 Ω

VIDEO section

VIDEO inputs / outputs	
VIDEO (composite)	1 Vp-p / 75 Ω

FM tuner section (For Europe)

Tuning frequency range	87.5 MHz ~ 108.0 MHz
Usable sensitivity (DIN at 75 Ω)	
MONO	1.3 μV / 13.2 dBf (40 kHz DEV., S/N 26 dB)
STEREO	45 μV / 42.1 dBf (46 kHz DEV., S/N 46 dB)
Total harmonic distortion (1 kHz)	
MONO	0.2% (71.2 dBf input)
STEREO	0.8% (71.2 dBf input)
Signal to noise ratio (DIN weighted at 1 kHz)	
MONO	65 dB (40 kHz DEV., 71.2 dBf input)
STEREO	60 dB (46 kHz DEV., 71.2 dBf input)
Stereo separation (DIN 1 kHz)	36 dB
Selectivity (DIN ±300 kHz)	64 dB
Frequency response	(30 Hz ~ 15 kHz), +0.5 dB, -3.0 dB

FM tuner section (For other countries)

Tuning frequency range	87.5 MHz ~ 108.0 MHz
Usable sensitivity (MONO)	
	1.6 μV (75 Ω) / 15.2 dBf (75 kHz DEV., SINAD 30 dB)
50dB quieting sensitivity	
STEREO	28 μV (75 Ω) / 40.2 dBf
Total harmonic distortion (1 kHz)	
MONO	0.5% (71.2 dBf input)
STEREO	0.7% (71.2 dBf input)
Signal to noise ratio (1 kHz, 75 kHz DEV.)	
MONO	75 dB (71.2 dBf input)
STEREO	68 dB (71.2 dBf input)
Stereo separation (1 kHz)	40 dB
Selectivity (±400 kHz)	50 dB
Frequency response	(30 Hz ~ 15kHz), +0.5 dB, -3.0 dB

AM tuner section (For Europe)

Tuning frequency range	531 kHz ~ 1,602 kHz
Usable sensitivity	16 μV / (600 μV/m)
Signal to noise ratio (30% mod. 1 mV input)	50 dB

AM tuner section (For other countries)

Tuning frequency range	
10 kHz step	530 kHz ~ 1,610 kHz
9 kHz step	531 kHz ~ 1,602 kHz
Usable sensitivity	16 μV / (600 μV/m)
Signal to noise ratio (30% mod. 1 mV input)	50 dB

GENERAL

Power consumption	280 W
AC outlet	
SWITCHED	(total 90 W max.)
Dimensions	W : 440 mm (17-5/16")
	H : 143 mm (5-5/8")
	D : 303 mm (11-15/16")
Weight (Net)	
KRF-V4080D	7.8 kg (17.2 lb)
KRF-V5580D (for the Australia and Europe)	7.8 kg (17.2 lb)
KRF-V5580D (for other countries)	8.8 kg (19.4 lb)

Notes

1. KENWOOD follows a policy of continuous advancements in development. For this reason specifications may be changed without notice.
2. The full performance may not be exhibited in an extremely cold location (under a water-freezing temperature).

KRF-V4080D/V5080D/V5580D-S/V6080D/VR-804-S/806

SPECIFICATIONS

KRF-V5080D/KRF-V6080D

AUDIO section (For Europe)

Rated power output during STEREO operation	
DIN/IEC (63 Hz ~ 12.5 kHz, 0.7% T.H.D., at 6 Ω)	100 W + 100 W
Effective power output during SURROUND operation	
FRONT	
(1 kHz, 0.7 % T.H.D. at 6 Ω one channel driven).....	100 W + 100 W
(1 kHz, 10 % T.H.D. at 6 Ω one channel driven).....	120 W + 120 W
CENTER	
(1 kHz, 0.7 % T.H.D. at 6 Ω one channel driven).....	100 W
(1 kHz, 10 % T.H.D. at 6 Ω one channel driven).....	120 W
SURROUND	
(1 kHz, 0.7 % T.H.D. at 6 Ω one channel driven).....	100 W + 100 W
(1 kHz, 10 % T.H.D. at 6 Ω one channel driven).....	120 W + 120 W
SURROUND BACK (KRF-V6080D)	
(1 kHz, 0.7 % T.H.D. at 6 Ω one channel driven).....	100 W
(1 kHz, 10 % T.H.D. at 6 Ω one channel driven).....	120 W
Total harmonic distortion	0.05 % (1 kHz, 50 W, 6 Ω)
Frequency response (IHF'66)	
CD/DVD	20 Hz ~ 70 kHz, 0 dB ~ -3.0 dB
Maximum input level	
PHONO (MM)	40 mV, 1.0 % T.H.D. at 1 kHz
Signal to noise ratio (IHF'66)	
PHONO (MM)	74 dB
CD/DVD, TAPE, VIDEO 1, VIDEO 2, DVD/6CH	95 dB
Loudness control	
VOLUME at -30 dB level	+8 dB (100 Hz)
Input sensitivity / impedance	
PHONO (MM)	7.5 mV / 27 k Ω
CD/DVD, TAPE, VIDEO 1, VIDEO 2	550 mV / 47 k Ω
DVD/6CH INPUT	550 mV / 15 k Ω
Output level / impedance	
TAPE REC.....	550 mV / 1 k Ω
PRE OUT (SUBWOOFER)	1.5 V / 2.2 k Ω
PRE OUT (SURROUND BACK).....	1.5 V / 2.2 k Ω
Tone control	
BASS	\pm 10 dB (at 100 Hz)
TREBLE.....	\pm 10 dB (at 10 kHz)

AUDIO section (For other countries)

Rated power output during STEREO operation

100 watts per channel minimum RMS, both channels driven, at 8 Ω from 40 Hz to 20 kHz with no more than 0.7% total harmonic distortion. (FTC)

Effective power output during SURROUND operation	
FRONT	
(1 kHz, 0.7% T.H.D. at 8 Ω one channel driven).....	100 W + 100 W
(1 kHz, 10% T.H.D. at 8 Ω one channel driven).....	120 W + 120 W
CENTER	
(1 kHz, 0.7% T.H.D. at 8 Ω one channel driven).....	100 W
(1 kHz, 10% T.H.D. at 8 Ω one channel driven).....	120 W
SURROUND	
(1 kHz, 0.7% T.H.D. at 8 Ω one channel driven).....	100 W + 100 W
(1 kHz, 10% T.H.D. at 8 Ω one channel driven).....	120 W + 120 W
SURROUND BACK (KRF-V6080D)	
(1 kHz, 0.7% T.H.D. at 8 Ω one channel driven).....	100 W
(1 kHz, 10% T.H.D. at 8 Ω one channel driven).....	120 W
Total harmonic distortion	0.05% (1 kHz, 50 W, 8 Ω)
Frequency response	
CD/DVD	20 Hz ~ 70 kHz, 0 dB, -3.0 dB
Signal to noise ratio (IHF'66)	
CD/DVD, AUX, TAPE, VIDEO 1, VIDEO 2	95 dB
Input sensitivity / impedance	
CD/DVD	550 mV / 47 k Ω
DVD/6CH INPUT	550 mV / 15 k Ω
Output level / impedance	
TAPE REC.....	550 mV / 1 k Ω
PRE OUT (SUBWOOFER)	1.5 V / 2.2 k Ω
PRE OUT (SURROUND BACK)(KRF-V6080D)	1.5 V / 2.2 k Ω
Tone control	
BASS	\pm 10 dB (at 100 Hz)
TREBLE.....	\pm 10 dB (at 10 kHz)
Loudness control	
VOLUME at -30dB level	+8 dB (at 100 Hz)

DIGITAL AUDIO section

Sampling frequency	32 kHz, 44.1 kHz, 48 kHz, 96 kHz
Input level / impedance / wave length	
Optical	(-15 dBm ~ -21 dBm), 660 nm \pm 30 nm
Coaxial	0.5 Vp-p / 75 Ω

VIDEO section (For Europe)

VIDEO inputs / outputs	
VIDEO (composite)	1 Vp-p / 75 Ω
S-VIDEO inputs / outputs(KRF-V6080D)	
S-VIDEO (luminance signal)	1 Vp-p / 75 Ω
S-VIDEO (chrominance signal)	0.286 Vp-p / 75 Ω
COMPONENT VIDEO inputs / outputs(KRF-V6080D)	
COMPONENT VIDEO (luminance signal)	1 Vp-p / 75 Ω
COMPONENT VIDEO (CB/CR-signal)	\pm 0.32 Vp-p / 75 Ω

VIDEO section (For other countries)

VIDEO inputs / outputs	
VIDEO (composite)	1 Vp-p / 75 Ω
S-VIDEO inputs / outputs	
S-VIDEO (luminance signal)	1 Vp-p / 75 Ω
S-VIDEO (chrominance signal)	0.286 Vp-p / 75 Ω
COMPONENT VIDEO inputs / outputs (KRF-V6080D)(KRF-V5080D:except for the Australia)	
COMPONENT VIDEO (luminance signal)	1 Vp-p / 75 Ω
COMPONENT VIDEO (CB/CR-signal)	\pm 0.32 Vp-p / 75 Ω

FM tuner section (For Europe)

Tuning frequency range	87.5 MHz ~ 108.0 MHz
Usable sensitivity (DIN at 75 Ω)	
MONO	1.3 μ V / 13.2 dBf (40 kHz DEV., S/N 26 dB)
STEREO	45 μ V / 42.1 dBf (46 kHz DEV., S/N 46 dB)
Total harmonic distortion (DIN at 1 kHz)	
MONO	0.2% (71.2 dBf input)
STEREO	0.8% (71.2 dBf input)
Signal to noise ratio (DIN weighted at 1 kHz)	
MONO	65 dB (40 kHz DEV., 71.2 dBf input)
STEREO	60 dB (46 kHz DEV., 71.2 dBf input)
Stereo separation (DIN 1 kHz)	36 dB
Selectivity (\pm 300 kHz)	64 dB
Frequency response (30 Hz ~ 15 kHz)	+0.5 dB, -3.0 dB

FM tuner section (For other countries)

Tuning frequency range	87.5 MHz ~ 108.0 MHz
Usable sensitivity (MONO)	1.6 μ V (75 Ω) / 15.2 dBf (75 kHz DEV., SINAD 30 dB)
50dB quieting sensitivity	
STEREO	28 μ V (75 Ω) / 40.2 dBf
Total harmonic distortion (1 kHz)	
MONO	0.5% (71.2 dBf input)
STEREO	0.7% (71.2 dBf input)
Signal to noise ratio (1 kHz, 75 kHz DEV.)	
MONO	75 dB (71.2 dBf input)
STEREO	68 dB (71.2 dBf input)
Stereo separation (1 kHz)	40 dB
Selectivity (\pm 400 kHz)	50 dB
Frequency response	(30 Hz ~ 15kHz), +0.5 dB, -3.0 dB

AM tuner section (For Europe)

Tuning frequency range	531 kHz ~ 1,602 kHz
Usable sensitivity (30% mod, S/N 20 dB)	16 μ V / (600 μ V/m)
Signal to noise ratio (30% mod, 400 Hz)	50 dB (60 dB μ V EMF input)

AM tuner section (For other countries)

Tuning frequency range	
10 kHz step	530 kHz ~ 1,610 kHz
9 kHz step	531 kHz ~ 1,602 kHz
Usable sensitivity	16 μ V / (600 μ V/m)
Signal to noise ratio (30% mod. 1 mV input)	50 dB

GENERAL

Power consumption.....	280 W
AC outlet	
SWITCHED	(total 90 W max.)
Dimensions	W: 440 mm (17-5/16")
	H: 143 mm (5-5/8")
	D: 303 mm (11-15/16")
Weight (Net)	
(for the Australia and Europe)	7.8kg (17.2 lb)
(for other countries).....	8.8kg (19.4 lb)

KRF-V4080D/V5080D/V5580D-S/V6080D/VR-804-S/806

VR-804/VR-806

AUDIO section

Rated power output during STEREO operation

100 watts per channel minimum RMS, both channels driven, at 8 Ω from 40 Hz to 20 kHz with no more than 0.7% total harmonic distortion. (FTC)
--

Effective power output during SURROUND operation

VR-804	
FRONT (40 ~ 20 kHz, 0.7% T.H.D. at 8 Ω one channel driven)	100 W + 100 W
CENTER (40 ~ 20 kHz, 0.7% T.H.D. at 8 Ω one channel driven)	100 W
SURROUND (40 ~ 20 kHz, 0.7% T.H.D. at 8 Ω one channel driven)	100 W + 100 W
VR-806	
FRONT (40 ~ 20 kHz, 0.7% T.H.D. at 8 Ω one channel driven)	100 W + 100 W
CENTER (40 ~ 20 kHz, 0.7% T.H.D. at 8 Ω one channel driven)	100 W
SURROUND (40 ~ 20 kHz, 0.7% T.H.D. at 8 Ω one channel driven)	100 W + 100 W
SURROUND BACK (40 ~ 20 kHz, 0.7% T.H.D. at 8 Ω one channel driven)	100 W
Total harmonic distortion	0.05% (1 kHz, 50 W, 8 Ω)
Frequency response	
CD/DVD	20 Hz ~ 70 kHz, 0 dB, -3.0 dB
Signal to noise ratio (IHF'66)	
CD/DVD, AUX, TAPE, VIDEO1, VIDEO2	95 dB
Input sensitivity / impedance	
CD/DVD	550 mV / 47 kΩ
Output level / impedance	
VR-804	
TAPE REC	550 mV / 1 kΩ
PRE OUT (SUBWOOFER)	1.5 V / 2.2 kΩ
VR-806	
TAPE REC	550 mV / 1 kΩ
PRE OUT (SUBWOOFER)	1.5 V / 2.2 kΩ
PRE OUT (SURROUND BACK)	1.5 V / 2.2 kΩ
Tone control	
BASS	±10 dB (at 100 Hz)
TREBLE	±10 dB (at 10 kHz)
Loudness control	
VOLUME at -30dB level	+8 dB (at 100 Hz)

DIGITAL AUDIO section

Sampling frequency	32 kHz, 44.1 kHz, 48 kHz, 96 kHz
Input level / impedance / wave length	
Optical	(-15 dBm ~ -21 dBm), 660 nm ±30 nm
Coaxial	0.5 Vp-p / 75 Ω

VIDEO section

VIDEO inputs / outputs	
VIDEO (composite)	1 Vp-p / 75 Ω
COMPONENT VIDEO inputs/outputs (VR-806)	
COMPONENT VIDEO (luminance signal)	1 Vp-p/75 Ω
COMPONENT VIDEO (CB/CR-signal)	±0.32 Vp-p/75 Ω

FM tuner section

Tuning frequency range	87.5 MHz ~ 108.0 MHz
Usable sensitivity (MONO)	1.3 μV (75 Ω) / 13.2 dBf (75 kHz DEV., SINAD 30 dB)
50dB quieting sensitivity	
STEREO	28 μV (75 Ω) / 40.2 dBf
Total harmonic distortion (1 kHz)	
MONO	0.5% (71.2 dBf input)
STEREO	0.7% (71.2 dBf input)
Signal to noise ratio (1 kHz, 75 kHz DEV.)	
MONO	75 dB (71.2 dBf input)
STEREO	68 dB (71.2 dBf input)
Stereo separation (1 kHz)	40 dB
Selectivity (±400 kHz)	70 dB
Frequency response	(30 Hz ~ 15kHz), +0.5 dB, -3.0 dB

AM tuner section

Tuning frequency range	530 kHz ~ 1,700 kHz
10 kHz step	16 μV / (600 μV/m)
Usable sensitivity (30% mod., S/N 20dB)	16 μV / (600 μV/m)
Signal to noise ratio (30% mod. 1 mV input)	50 dB

GENERAL

Power consumption	2.2 A
AC outlet	
SWITCHED	(total 150 W, 1.25 A max.)
Dimensions	W : 440 mm (17-5/16")
	H : 143 mm (5-5/8")
	D : 303 mm (11-15/16")
Weight (Net)	7.7 kg (17.0 lb)

Notes

1. KENWOOD follows a policy of continuous advancements in development. For this reason specifications may be changed without notice.
2. The full performance may not be exhibited in an extremely cold location (under a water-freezing temperature).