

KR-V6050/7050

SERVICE MANUAL

KENWOOD

©1993-2 PRINTED IN JAPAN
B51-4700-00(S)4404

For Service Manuals Contact
MAURITRON TECHNICAL SERVICES
8 Cherry Tree Rd, Chinnor
Oxon OX9 4QY
Tel:- 01844-351694 Fax:- 01844-352554
Email:- enquiries@mauritron.co.uk

KR-V6050

Metallic cabinet
(A01-2998-11)

Front glass
(B10-1945-23): K, P, Y, M, X
(B10-1947-23): T, E

Panel
(A60-0314-02): K, P, Y, M, X, T
(A60-0315-02): E

Knob (VOLUME)
(K29-5613-04)

1057

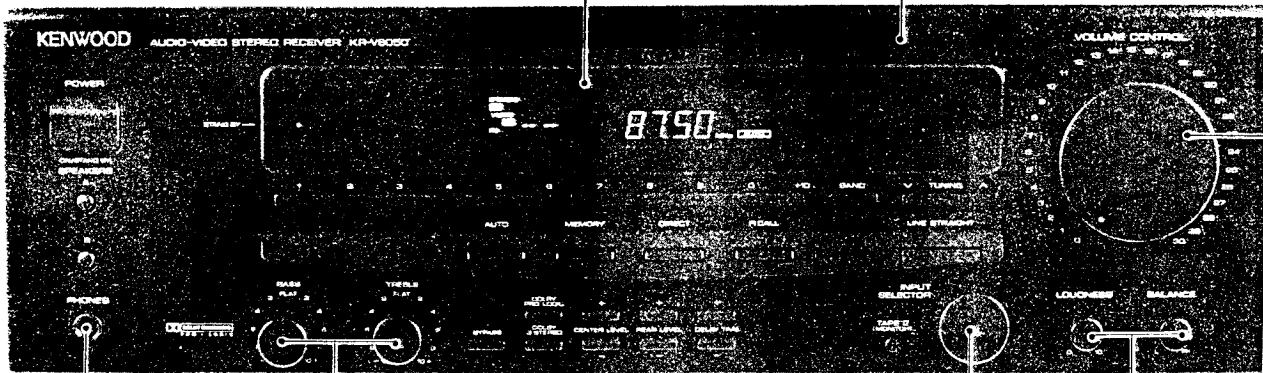

Phone jack*
(E11-)

Knob
(K29-5611-04)

Knob
(K29-5612-04)

Knob
(K29-5672-04)

Slide switch
(S31-2132-05)

Lock terminal
(E20-)

Phono jack
(E63-0068-05)

Phono jack
(E63-0070-05) x 2

Slide switch
(S62-0001-05)

Power cord bushing
(J42-0083-05)

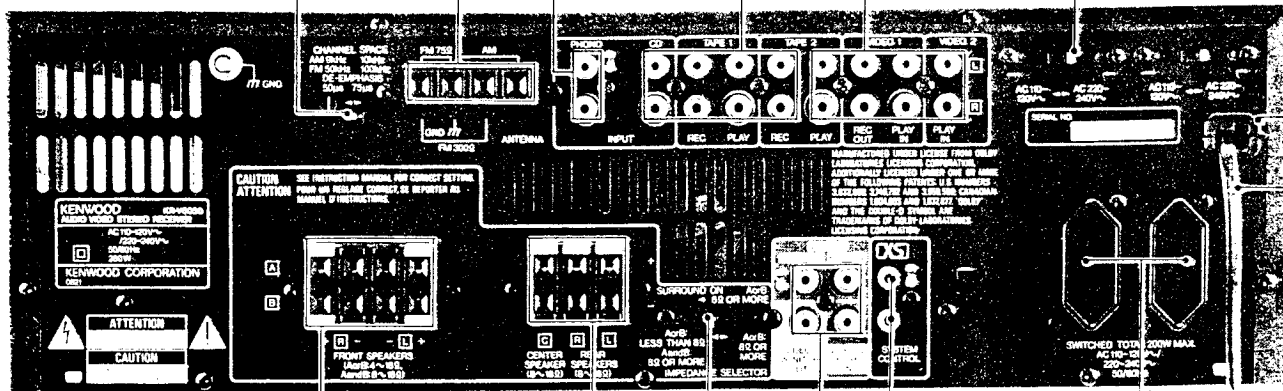

Lock terminal board*
(E70-)

Lock terminal board*
(E70-)

Phono jack
(E63-0069-05)

Miniature phono jack
(E11-0188-05)

AC outlet*
(E03-)

AC power cord*
(E30-)

KR-V6050/7050

CONTENTS

FUNCTION	3	ABGLEICH	45
ACCESSORIES	3	ADJUSTMENT/REGLAGE/ABGLEICH	46
DISASSEMBLY FOR REPAIR	4	WIRING DIAGRAM	47
REMOTE CONTROL OPERATION	6	PC BOARD	51
CONTROL INDICATOR	8	SCHEMATIC DIAGRAM (KR-V6050)	57
BLOCK DIAGRAM	13	SCHEMATIC DIAGRAM (KR-V7050)	65
CIRCUIT DESCRIPTION	19	EXPLODED VIEW (UNIT)	81
ADJUSTMENT	43	PARTS LIST	83
REGLAGE	44	SPECIFICATIONS	107

KR-V7050

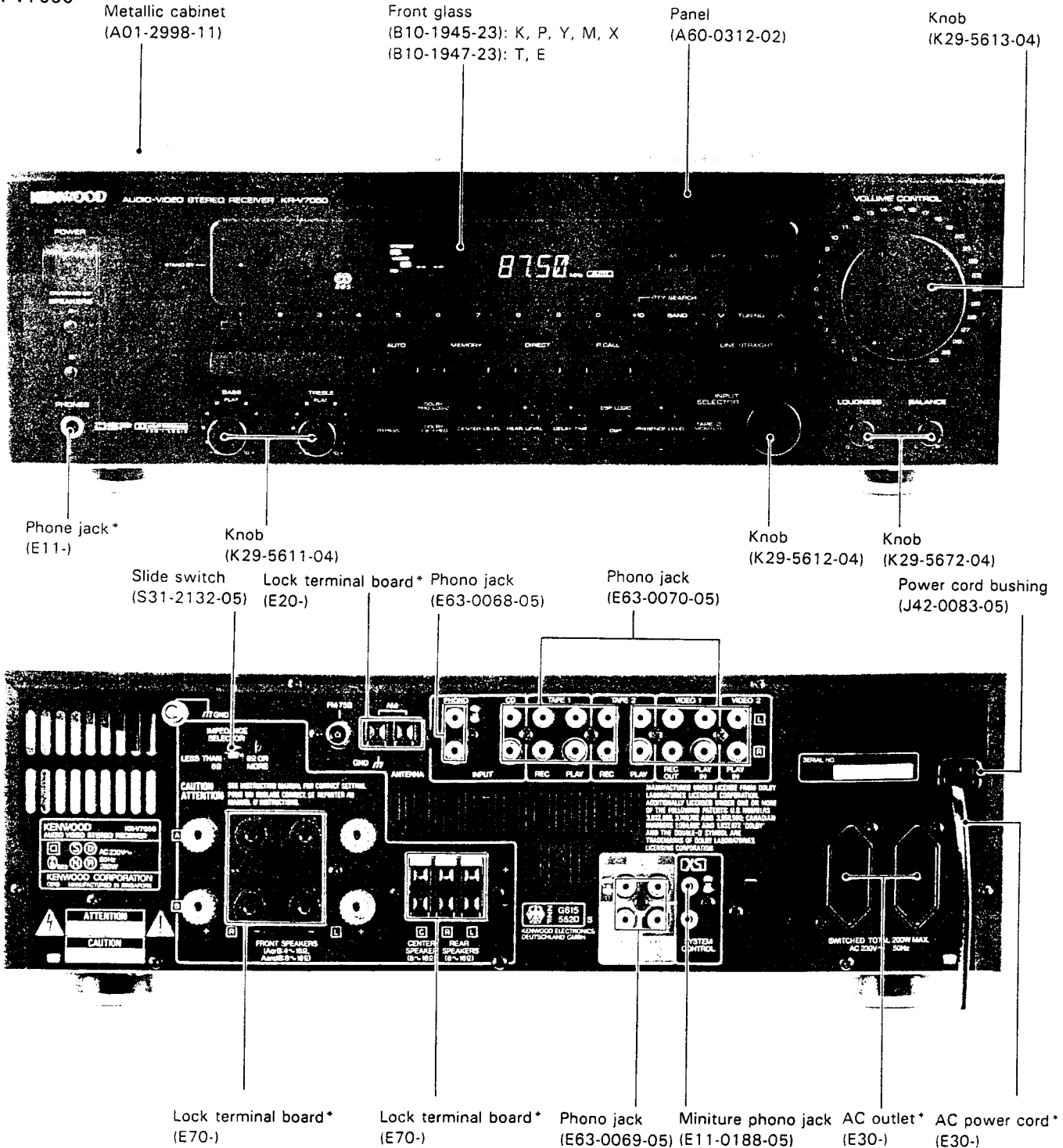

*Refer to parts list on page 83.

KR-V6050/7050



FUNCTION

	KR-V6050			KR-V7050		
	K,P,M,Y,X	E	T	K,P,M,Y,X	E	T
PRO LOGIC/3 STEREO	○		○	○	○	
DSP/DSP LOGIC				○	○	
RDS (AF, PTY, DISPLAY)		○	○			○
Large SP Terminal		○				○
MUTE (Remote control unit)		○		○		○



○: There is the function

[SPEAKER IMPEDANCE SELECTOR and SURROUND OUTPUT]

KR-V6050: When the IMPEDANCE SELECTOR is in  position, sound is not output from the center and rear speakers.

KR-V7050: When the IMPEDANCE SELECTOR is in  or  position, sound is output from the center and rear speakers.

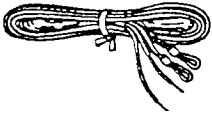
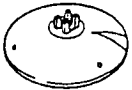
Accessories

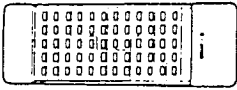
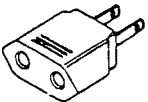
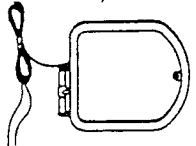
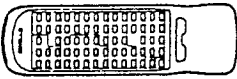
FM indoor antenna 1 (T90-0175-05)	Loop antenna holder 1 (J19-2815-04)
	
Batteries ('R03' or 'AAA') 2	Remote control unit 1
	KR-V6050
AC plug adaptor 1 (E30-0115-05)	
	A70-0925-05 KPVMXT A70-0926-05 E BATTERY COVER A09-0106-08
(Except for some areas)	Remote control unit 1
AM loop antenna 1 (T90-0174-05)	KR-V7050
	
	X94-1010-91 KPVMX X94-1011-11 TE BATTERY COVER A09-0126-03

For Service Manuals Contact
MAURITRON TECHNICAL SERVICES
 8 Cherry Tree Rd, Chinnor
 Oxon OX9 4QY
 Tel: 01844-351694 Fax: 01844-352554
 Email: enquiries@mauritron.co.uk

Removing the chassis for repair.

1. Cut the 6 places with a pair of nippers. ①.
2. Move the unit holder from the current position to the open mounting position. ②.
3. Rotate the lid, which was cut off, by 180° degrees. ③.

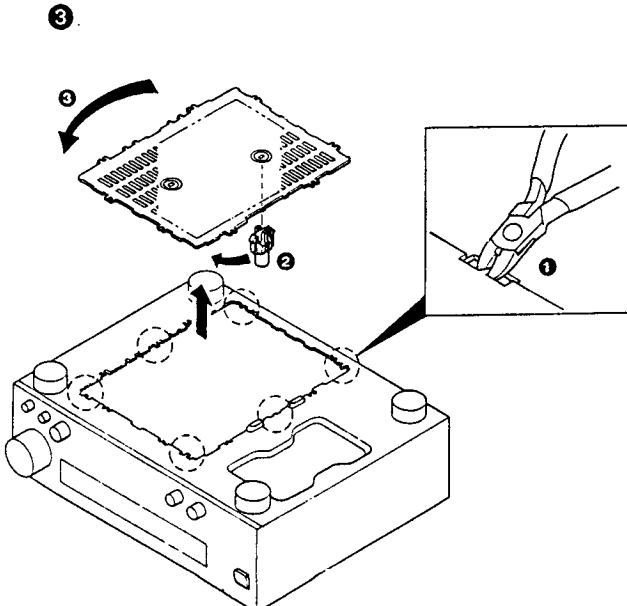

4. Insert the lids in the 2 places of the chassis ④, and mount them with the 6 screws (3 × 6) ⑤.

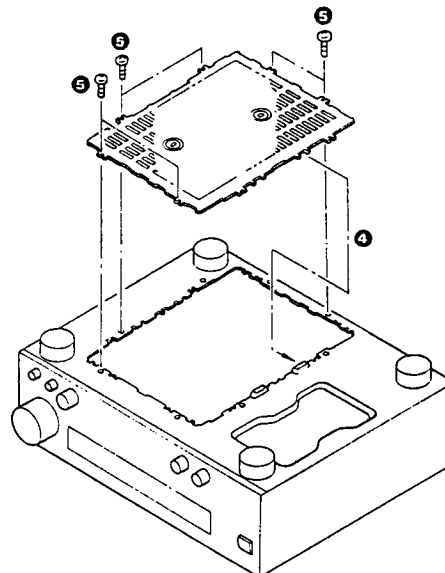

KR-V6050/7050

DISASSEMBLY FOR REPAIR

1. Remove the 6 screws ❶, press the 2 claws ❷ of the sub-panel, and remove the front panel.
2. Remove the 6 knobs ❸ and the nut ❹.
3. Remove the 4 screws ❺ and remove the sub-panel together with the circuit board.
4. Remove the 6 screws ❻, pull the 14 claws ❼ of the sub-panel, and remove the circuit board.

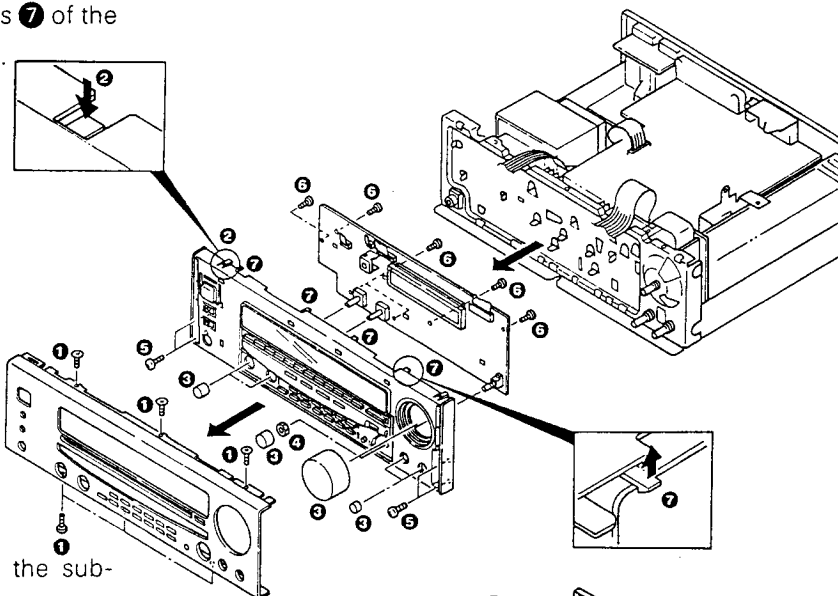

5. Remove the 6 screws ❸, and pull out the sub-chassis.
6. Remove the screw ❹, and disconnect the phone jack by pressing the claw ❺.
7. The volume control (X13) (D/6), the loudness and the balance (X13) (E/3) can be removed when the 2 screws ❹ and the nut ❺ are removed.

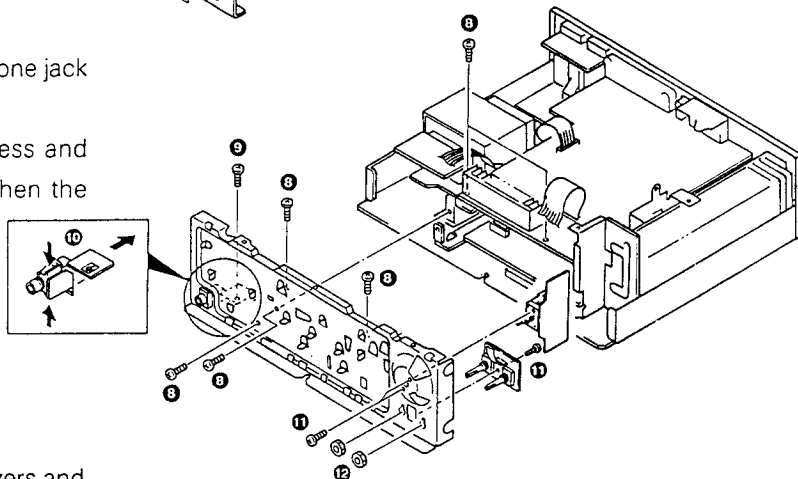

8. Remove the 4 screws ❸.
9. Remove the 7 screws ❹.
10. Hold the extremity of the 2 clamps with tweezers and the like, and remove the circuit board ❹.
11. In the case of the E. T type, remove the parallel lead wires of CN4.

*When assembling, take care for the cord not be caught between the two circuit boards. ❹.

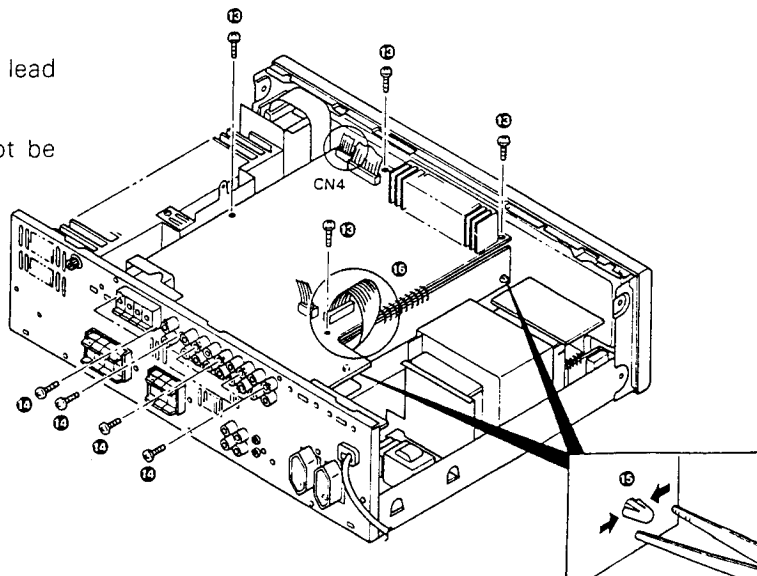

KR-V6050/7050

DISASSEMBLY FOR REPAIR

After removing from <X14> PCB body.

12. Turn the circuit board as a whole upside-down, and lay a piece of cloth between the circuit board and the chassis. 17.
13. When checking the tuner unit of X14, make sure of connecting the GND (TP17) of the tuner unit with the GND of the chassis with an alligator clip and the like. 18.

*When assembling, position the clamps parallel to the chassis. 19.

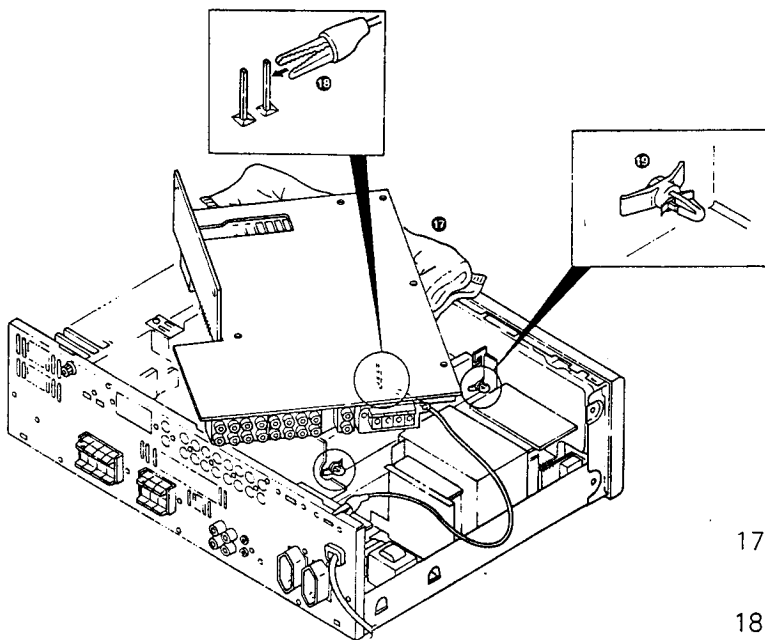

Removing the RDS unit.

14. Remove the 2 screws 20, and then remove the screws 21 to remove the circuit board.

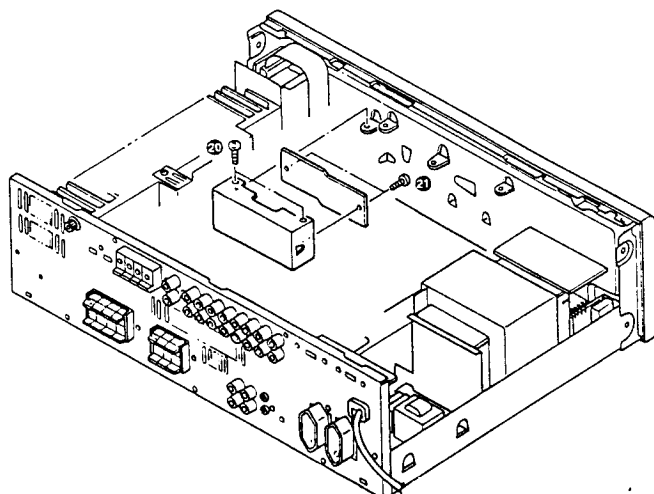

15. Remove the 7 screws 22, and let the circuit board get afloat.
16. Moreover, remove the 15 screws 23.

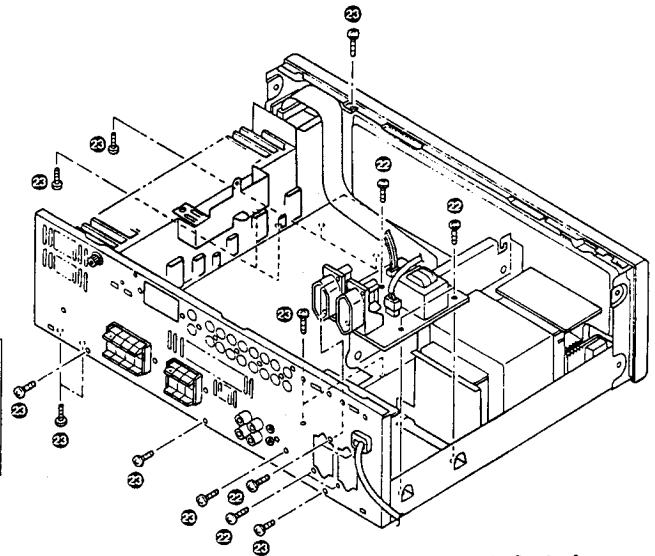

For Service Manuals Contact
MAURITRON TECHNICAL SERVICES
 8 Cherry Tree Rd, Chinnor
 Oxon OX9 4QY
 Tel:- 01844-351694 Fax:- 01844-352554
 Email:- enquiries@mauritron.co.uk

17. Undo the connector (CN4) 24 of the circuit boards (X13) (B/6).
18. Put up the main circuit board sideways. 25.
19. Lay a piece of cloth between the main board and the chassis. 26.

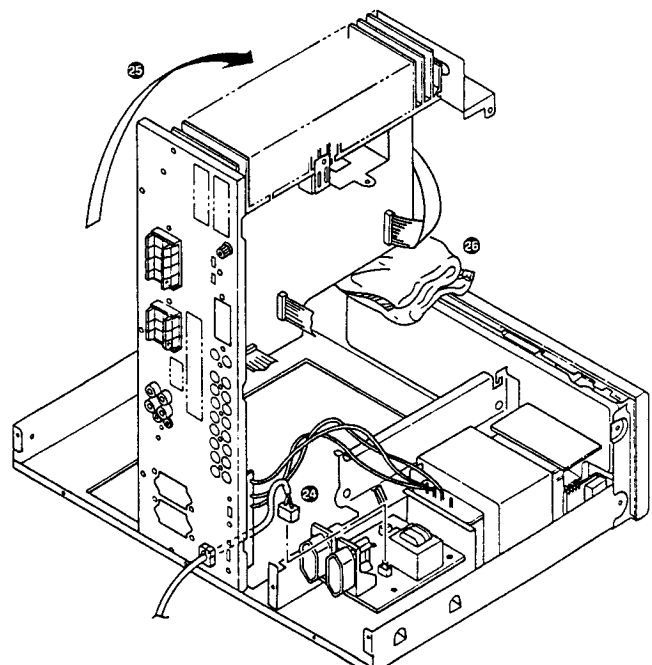

Remote control unit: KR-V7050 (K, P, M, Y, X Type)

■ Basic operation keys

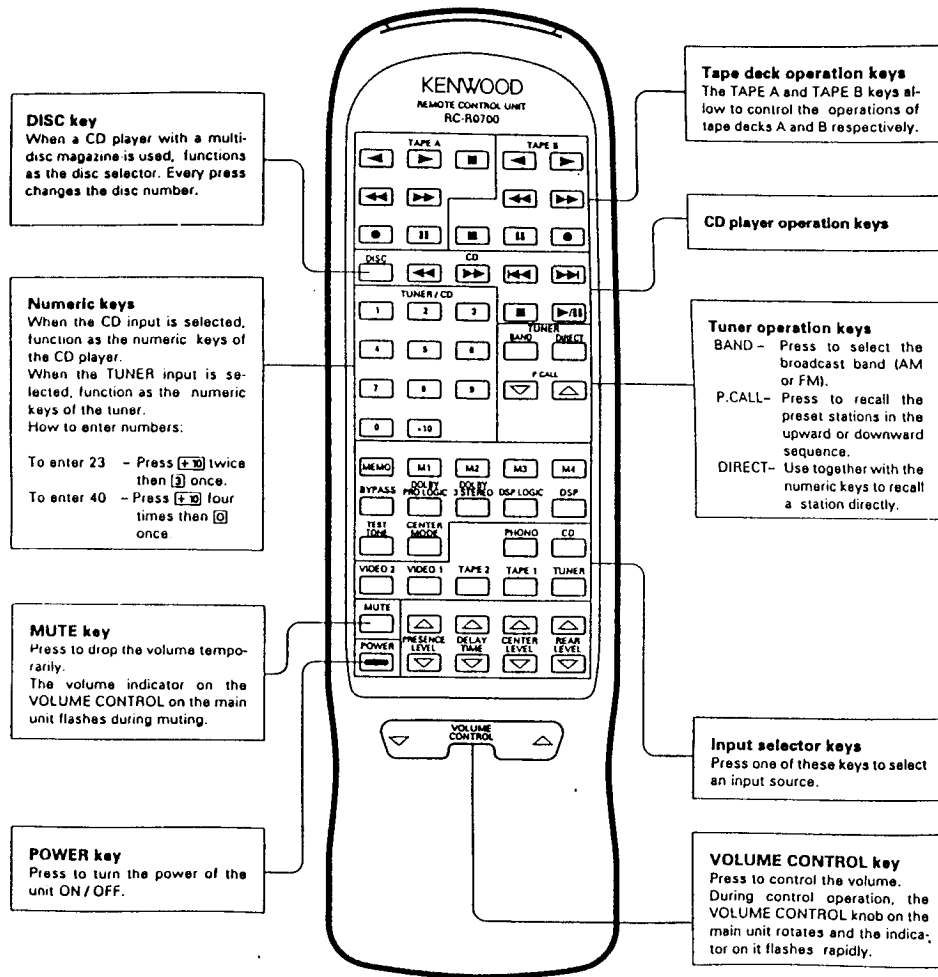

Remote control unit: KR-V7050 (E, T Type)

■ Basic operation keys

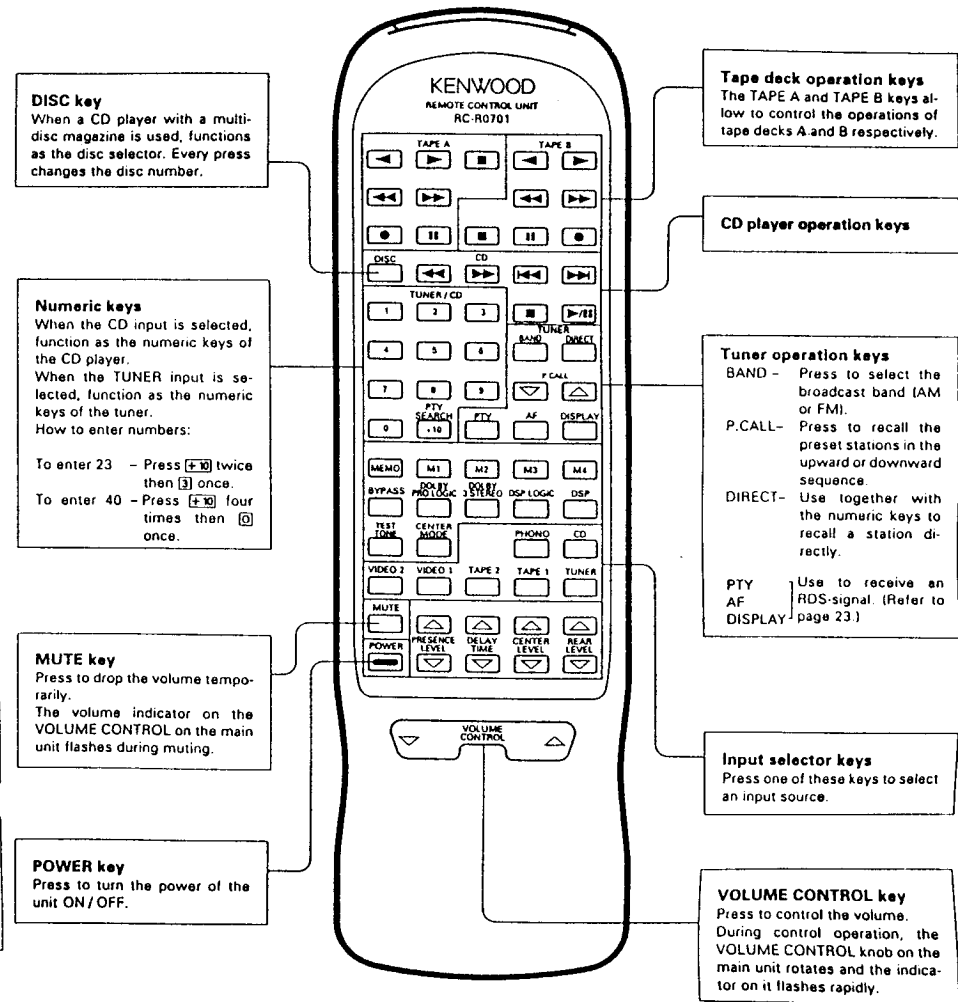

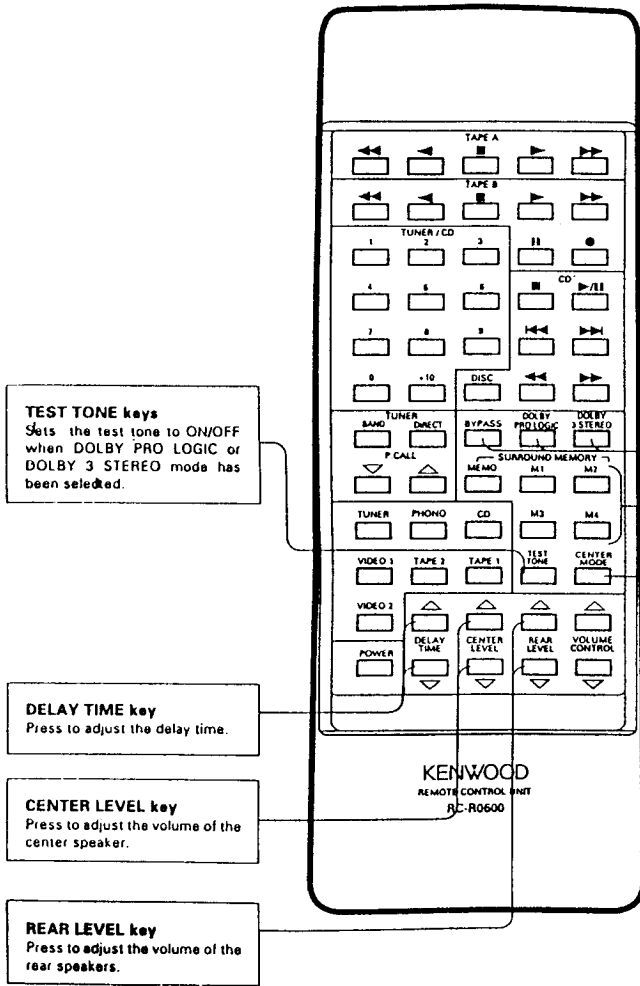

DOLBY PRO LOGIC key
Press to initiate the Dolby Pro Logic mode.

DOLBY 3 STEREO key
Press to initiate the DOLBY 3 Stereo mode.

The keys above are used to switch the sound field modes.

BYPASS key
Press to release the presence modes.

SURROUND keys

MEMO key
Press to store the current presence mode in memory.

M1 ~ M4 keys
Press to recall a presence mode from the memory.

CENTER MODE key
Press to adjust the center mode in the Pro Logic, DOLBY 3 STEREO or DSP Logic mode.

POWER key
Press to turn the power of the unit ON / OFF.

CD player operation keys

DISC key
When a CD player with a multi-disc magazine is used, functions as the disc selector. Every press changes the disc number.

Numeric keys
When the CD input is selected, function as the numeric keys of the CD player. When the TUNER input is selected, function as the numeric keys of the tuner. How to enter numbers:
To enter 23 - Press [2] twice then [3] once.
To enter 40 - Press [4] four times then [0] once.

MUTE key
Press to drop the volume temporarily. The volume indicator on the VOLUME CONTROL on the main unit flashes during muting.

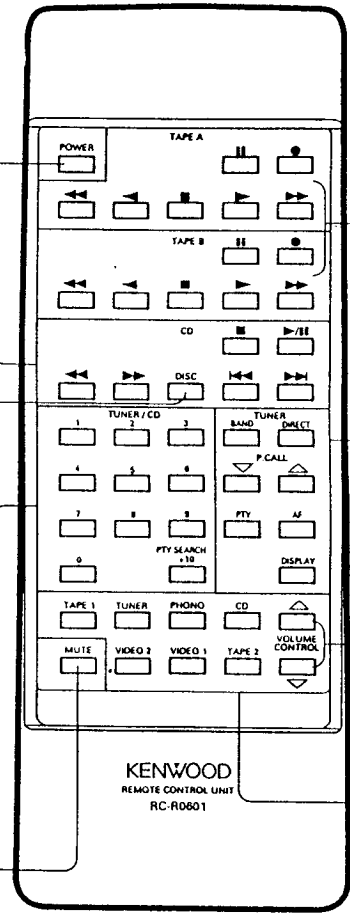

Tape deck operation keys
The TAPE A and TAPE B keys allow to control the operations of tape decks A and B respectively.

Tuner operation keys
BAND - Press to select the broadcast band (AM or FM).
P.CALL - Press to recall the preset stations in the upward or downward sequence.
DIRECT - Use together with the numeric keys to recall a station directly.
PTY / AF / RDS - Use to receive an RDS-signal. (Refer to page 22)

VOLUME CONTROL key
Press to control the volume. During control operation, the VOLUME CONTROL knob on the main unit rotates and the indicator on it flashes rapidly.

input selector keys
Press one of these keys to select an input source.

For Service Manuals Contact
MAURITRON TECHNICAL SERVICES
8 Cherry Tree Rd, Chinnor
Oxon OX9 4QY
Tel: 01844-351694 Fax: 01844-352554
Email: enquiries@mauritron.co.uk

REMOTE CONTROL OPERATION

KR-V6050/7050

Refer to page 23 for a description of the RDS feature.

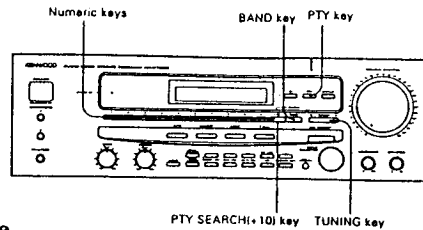

■ Searching for a desired program type

<PTY (Program Type Identification) Search>

By specifying the type of program (genre) you want to listen to, the tuner automatically searches for a station which is currently broadcasting a program of the specified type.

1 Set the broadcast band to FM.

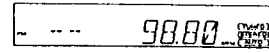
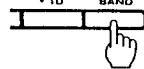

2 Select the search mode.

Press the PTY key.



When an RDS broadcast is received, the program type is shown on the display. If no PTY data is available or if the station is not an RDS station, "NONE" is displayed.

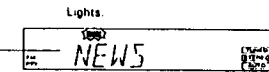

- Perform step 3 within 5 seconds after the program type is shown on the display.

3 Select the desired program type.

Select while "PTY" is lit.

Use the numeric keys to directly select one of the ten program types numbered (1) to (0).



Press the TUNING (P CALL) key to sequentially select from the fifteen available program types. Release the key when the desired program type is displayed.

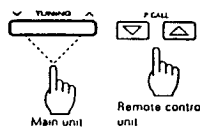

DOWN	Program Type Name	Display
1	Pop Music	POP M
2	Rock Music	ROCK M
3	* M.O.R. Music	M.O.R. M
4	Light Classical	LIGHT M
5	Serious Classical	CLASSICS
6	Other Music	OTHER M
7	News	NEWS
8	Current Affairs	AFFAIRS
9	Information	INFO
0	Sport	SPORT
—	Education	EDUCATE
—	Drama	DRAMA
—	Culture	CULTURE
—	Science	SCIENCE
—	Varied	VARIED

* M.O.R. Music (Middle of the Road Music)

4 Start the search.

Press while "PTY" is lit

Display while the tuner is searching

Program type name display

- No sound is heard while "PTY" is blinking
- If a program of the desired type cannot be found, "NO PROG" is displayed, then after several seconds the display returns to the original display.
- If a program of the desired type is found, that program is received and the program type name display changes temporarily to the frequency display and then to the station name display

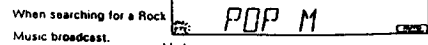

To change to a different program type:

- Repeat steps 2 - 3

Refer to page 23 for a description of the RDS feature.

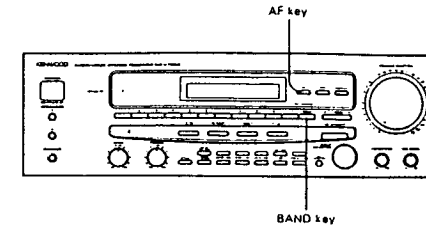

■ Searching for the best frequency

<AF (Alternative Frequencies) Search>

If more than one FM station is broadcasting the same program, this function will automatically select the station offering the strongest signal or the least interference. (The AF feature will not function if the [RDS] indicator is not lit.)

1 Set the broadcast band to FM.

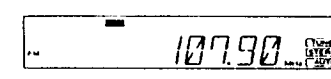
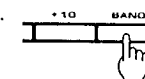

2 Receive an RDS broadcast station.

Check that the indicator is lit.

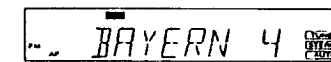

- Tune in the desired station and verify that the [RDS] indicator lights.
- After a short time, the "AF" indicator lights. After verifying that the "AF" indicator is lit, proceed to the next step.

3 Select the search mode.

Press the AF key



Display while the tune is searching

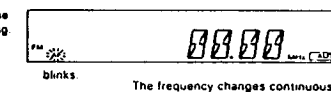

When a station is received.

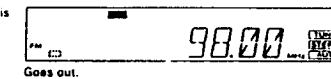

After about several seconds

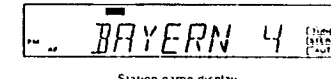

- Scanning (station searching) starts
- No sound is heard while searching is being carried out.
- When a station is found, the "AF" indicator goes out.
- After several seconds, the station name is displayed.

AF (Alternative Frequencies) Feature

- With some stations, it may take some time for the "AF" indicator to light.
- To obtain the best reception conditions, we recommend waiting a few minutes after the "AF" indicator lights before pressing the [AF] key.
- It is useful to use the number keys to preset (memorize) stations received with this AF function. (See page 21)
- The selected frequency may vary depending on the signal conditions.
- There are some RDS stations which do not support this AF function. For such stations, the "AF" indicator does not light.

For Service Manuals Contact
MAURITRON TECHNICAL SERVICES
 8 Cherry Tree Rd, Chinnor
 Oxon OX9 4QY
 Tel:- 01844-351694 Fax:- 01844-352554
 Email:- enquiries@mauritron.co.uk

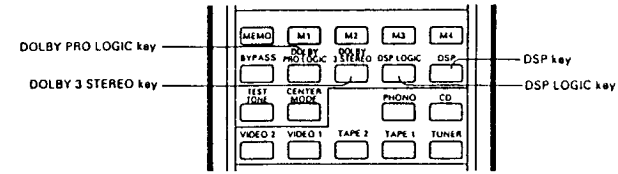

[Example KR-V7050]

RDS (Radio Data System) : E, T Typeonly

RDS is a system which transmits useful information (digital data) for FM broadcasts together with the broadcast signal. Tuners and receivers designed for RDS reception can extract the information from the broadcast signal for use with various functions such as automatic display of the station name.

This unit is equipped with the following functions utilizing RDS data:

(In some areas, some functions cannot be activated and some function names are differ as follows.)

PTY (Program Type Identification) Search: (See page 24)

The tuner automatically searches for a station which is currently broadcasting a specified program type (genre).

AF (Alternative Frequencies) Search: (See page 25)

When a weak signal is received, the tuner automatically searches for alternative frequencies broadcasting the same program and selects the best signal.

PS (Program Service Name) Display: (refer to the table below.)

When an RDS broadcast is received, the station name is automatically displayed.

CT (Clock Time) Display: (refer to the table below.)

Some RDS stations transmit clock data along with the broadcast signal. When the CT display is selected with the [DISPLAY] key, the hour and minute are displayed.

The RDS indicator lights when an RDS broadcast (signal) is received.

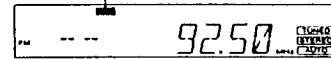

DISPLAY key

Pressing the DISPLAY key changes the display contents. The display returns to the original display after about 5 seconds.



Display mode priority ranking

When an RDS broadcast is received: ① → ② → ③

① PS (Program Service Name) Display:

When an RDS broadcast is received, the station name is automatically displayed. If no PS data is transmitted, the display changes to the ② Frequency display.

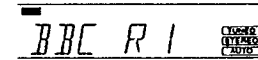

② Frequency Display:

The frequency of the current station is displayed.

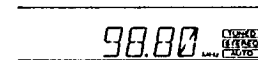

③ CT (Clock Time) Display:

When an RDS broadcast is received, the hour and minute are shown on the display. If no clock data is available, the clock time is not displayed and the program service name is displayed.

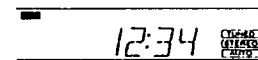

Speaker positioning

Standard layout

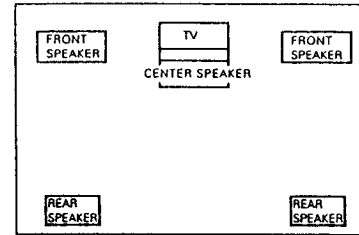

① **Dolby PRO LOGIC mode** [without KR-V6050 E type]
 Set the center mode according to the size of the center speaker.

NORMAL : When the center speaker size is small.
WIDE BAND : When the center speaker size is large or medium.

② **DSP LOGIC mode** [KR-V7050 only]
 Set the center mode to "4 CH MODE" and select the desired presence mode.

When no rear (surround) speakers are used

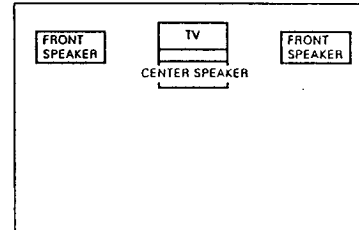

Dolby 3 STEREO mode [without KR-V6050 E type]
 Set the center mode according to the center speaker size.

NORMAL : when using a small center speaker.
WIDE BAND : when using a medium-sized or larger center speaker.

When no center speaker is used

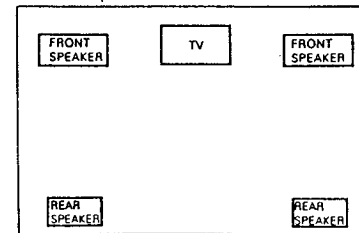

① **Dolby PRO LOGIC mode** [without KR-V6050 E type]
 Set the center mode to PHANTOM.

② **DSP mode** [KR-V7050 only]
 Select the desired presence mode.

③ **DSP LOGIC mode** [KR-V7050 only]
 Set the center mode to "3 CH MODE" and select the desired presence mode.

CONTROLS & INDICATORS / OPERATION OF CONTROL

KR-V6050/7050

Dolby 3 STEREO Mode

The Dolby 3 STEREO provides a active center channel to produce a better, stable center image. This mode can be used when listening to stereo video program and music or when surround listening or surround system set-up not possible.

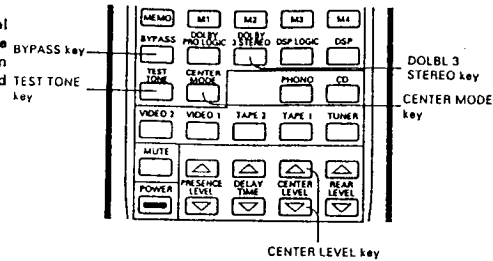

Dolby 3 STEREO adjustment

- 1 Set the Dolby 3 STEREO mode.**

Remote control unit

Lights up
- 2 Select the center mode.**

Every time the key is pressed, the center mode is switched.

Remote control unit only

NORMAL ↔ WIDE BAND

 - Set the center mode to NORMAL if using a small center speaker, or set to WIDE BAND if using a medium-sized or larger speaker.
- 3 Adjust the center speaker volume.**

① Press the TEST TONE key.

Remote control unit only

A buzzing sound comes from the speaker. It is switched every one and half second for each other.

 - Press at the listening position.
 - When at 3 stereo sound is produced in the sequence: LEFT → CENTER → RIGHT (REAR not available with 3 stereo mode.)

② Adjust the volume.

Remote control unit

 - And adjust so that the level of the center speaker is equal to that of the left and right speakers.
 - The rear level adjustment is invalid.
- 4 Stop generating the test tone.**

Remote control unit only

Press the key again.

Dolby 3 STEREO playback

- 1 Set the Dolby 3 STEREO mode.**

Remote control unit

Lights up
- 2 Select the center mode.**

Every time the key is pressed, the center mode is switched.

Remote control unit only

NORMAL ↔ WIDE BAND

 - Set the center mode to NORMAL if using a small center speaker, or set to WIDE BAND if using a medium-sized or larger speaker.
- 3 Play a stereo software program or a Dolby surround program.**
- 4 Adjust the volume and tone.**

Main unit

To return to normal stereo playback.

Remote control unit

Goes off

DSP / DSP LOGIC Presence

The DSP (Digital Signal Processor) allows to reproduce the atmospheres of various sound fields. By applying additional adjustments, a custom presence effect of yourself can also be created.

- DSP presence modes ARENA, JAZZ CLUB, STADIUM, DISCOTHEQUE
- DSP Logic presence modes ... LARGE THEATER, SMALL THEATER

Satisfactory effect can be enjoyed by selecting one of the presence modes by referring to the table below. Additionally, the parameters shown in the table can also be adjusted according to your liking.

- Presence level : Variable in the range from - 20 to 0 dB.
 Delay time : Variable in the range from 3 to 50 ms.
 Rear level : Variable in the range from - 30 to + 10 dB.
 Center level : Variable in the range from - 30 to + 10 dB.

Presence mode	Initial setting values			Variable setting values	
	CHANNEL MODE	DELAY TIME	PRESENCE LEVEL	CENTER LEVEL	REAR LEVEL
ARENA	*	10 ms	- 12 dB	*	- 30 dB - + 10 dB
JAZZ CLUB	*	16 ms	- 12 dB	*	- 30 dB - + 10 dB
STADIUM	*	26 ms	- 8 dB	*	- 30 dB - + 10 dB
DISCOTHEQUE	*	16 ms	- 8 dB	*	- 30 dB - + 10 dB
LARGE THEATER	3ch	32 ms	- 8 dB	*	- 30 dB - + 10 dB
	4ch	32 ms	- 8 dB	- 30 dB - + 10 dB	- 30 dB - + 10 dB
SMALL THEATER	3ch	16 ms	- 16 dB	*	- 30 dB - + 10 dB
	4ch	16 ms	- 16 dB	- 30 dB - + 10 dB	- 30 dB - + 10 dB

- ARENA A hall where high frequencies are reflected very well and reverberations are long.
- JAZZ CLUB A live house of jazz where cymbals sounds well.
- STADIUM A stadium with reflections proper to PA speakers.
- DISCOTHEQUE A disco where medium-frequency range is enhanced by comfortable reverberations.
- LARGE THEATER Reproduces a surround sound proper to a large movie theater.
- SMALL THEATER Reproduces the sound field of a small movie theater or hall.

CONTROLS & INDICATORS

KR-V6050/7050

For Service Manuals Contact
 MAURITRON TECHNICAL SERVICES
 8 Cherry Tree Rd, Chinnor
 Oxon OX9 4QY
 Tel: 01844-351694 Fax: 01944-352554
 Email: enquiries@mauriftron.co.uk

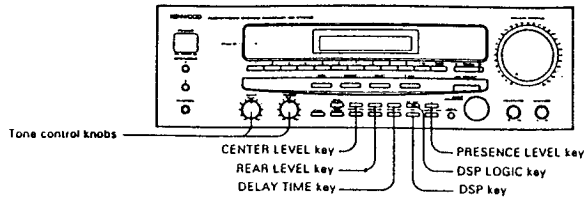

■ Creating a DSP sound field

1 Select the presence mode.

Main unit or Remote control unit

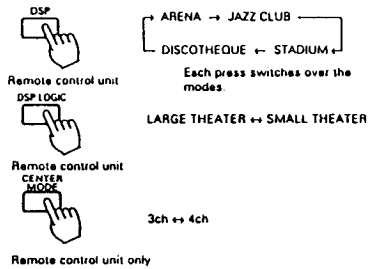

- Press the **GENTER MODE** key only in the **DSP LOGIC** mode.

2 Play the music source.

Now, a sufficient sound field effect of the presence mode can be obtained. However, you can make additional adjustments as described in the following.

- Even when the following presence parameters have been adjusted, they will return to the initial settings when the Dolby Surround mode or another presence mode is selected.

3 Adjust the presence level.

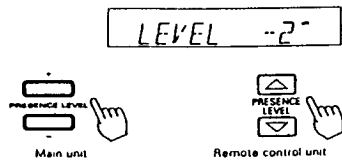

- Set in 2 dB steps within a range of -20 to 0 dB.

4 Adjust the volume.

- Adjust the center level.
 - Set within a range of -30 to +10 dB

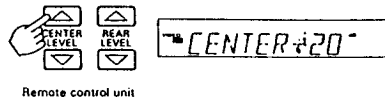

- Adjust the rear level.
 - Set within a range of -30 to +10 dB.



- Perform step ① only when the **DSP LOGIC** mode is set to "4 CH MODE".

5 Adjust the sound quality. [Main unit only]



6 Set the delay time.



- The delay time can be adjusted within a range of 3 ms to 50 ms.

Surround information memory functions

For the enjoyment in Surround modes, it is required to set the levels of the channels, delay time, etc., as described on pages 29, 30, 31, 32, and 33. The Surround information memory function makes it possible to store such information in memory.

The Surround Information Memory function allows to store up to four sets of Surround information.

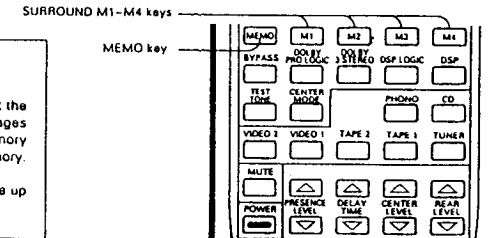

■ How to save Surround setup in memory [Remote control unit only]

1 Select or create the surround setup to be saved.

- **BYPASS** cannot be stored.

2 Press the MEMO key.

- Proceed to the step 3 while the display shown right is lighted.
- The unit enters storing stand by mode.



3 Press the M1 ~ M4 key.

- Set to M1-M4.



■ How to recall a Surround setup [Remote control unit only]

To recall a pattern from the Surround memory, Press one of the M1 to M4 keys to recall a pattern directly from the Surround memory.

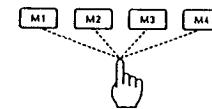

KR-V6050/7050 KR-V6050/7050

BLOCK DIAGRAM

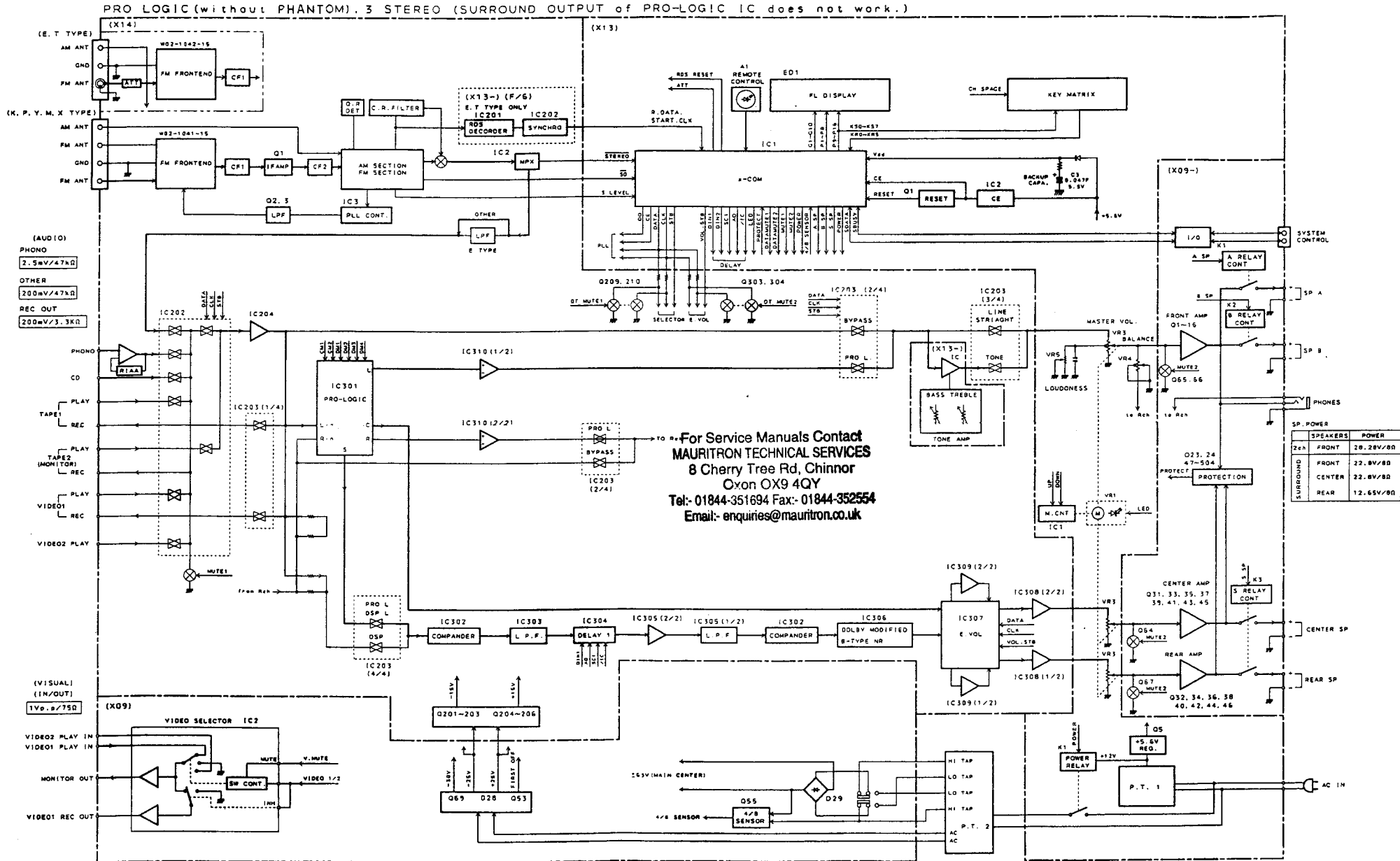

KR-V6050/7050 KR-V6050/7050

BLOCK DIAGRAM

For Service Manuals Contact
MAURITRON TECHNICAL SERVICES
 8 Cherry Tree Rd, Chinnor
 Oxon OX9 4QY
 Tel: 01844-351694 Fax: 01844-352554
 Email: enquiries@mauritron.co.uk

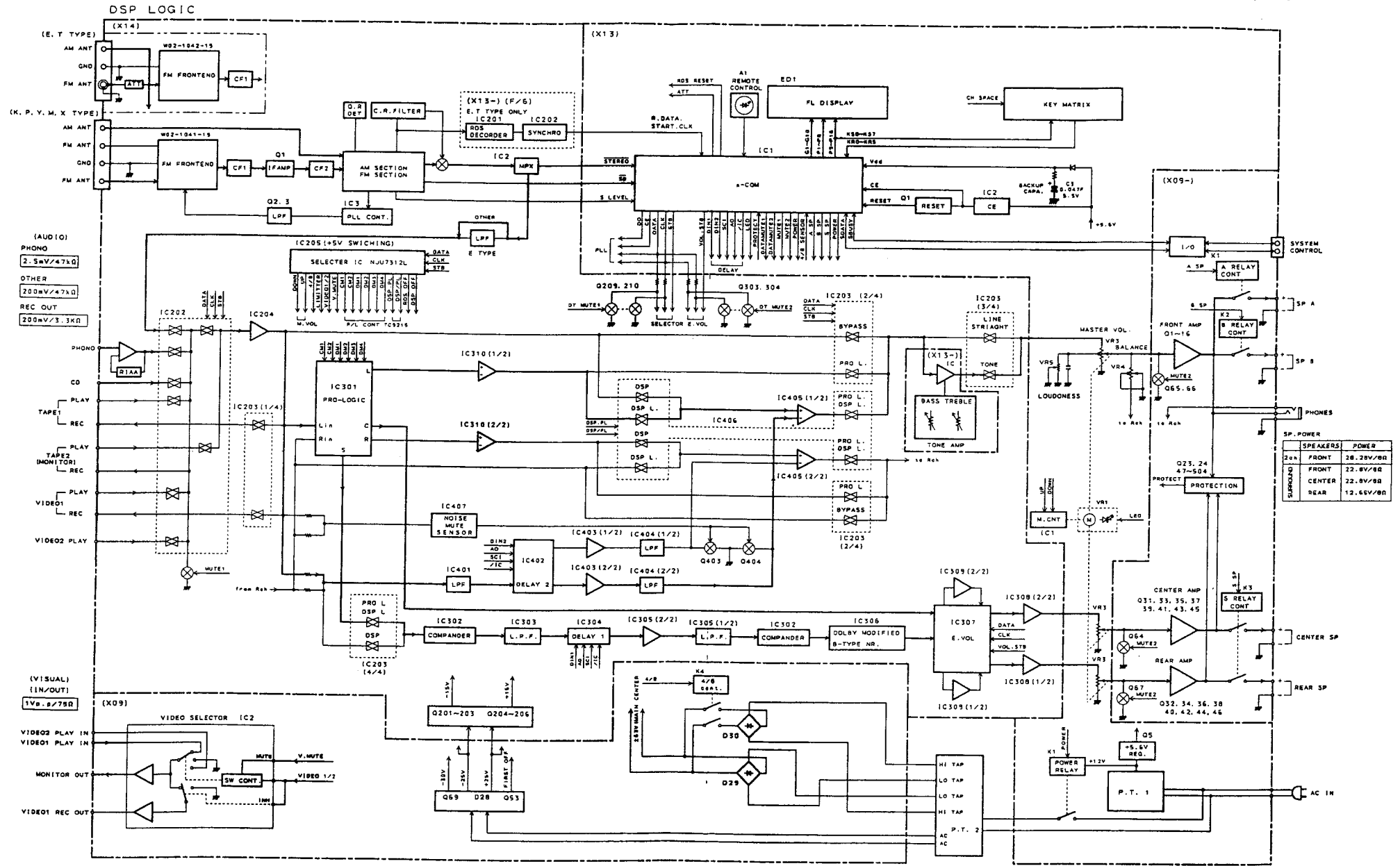

KR-V6050/7050 KR-V6050/7050

BLOCK DIAGRAM

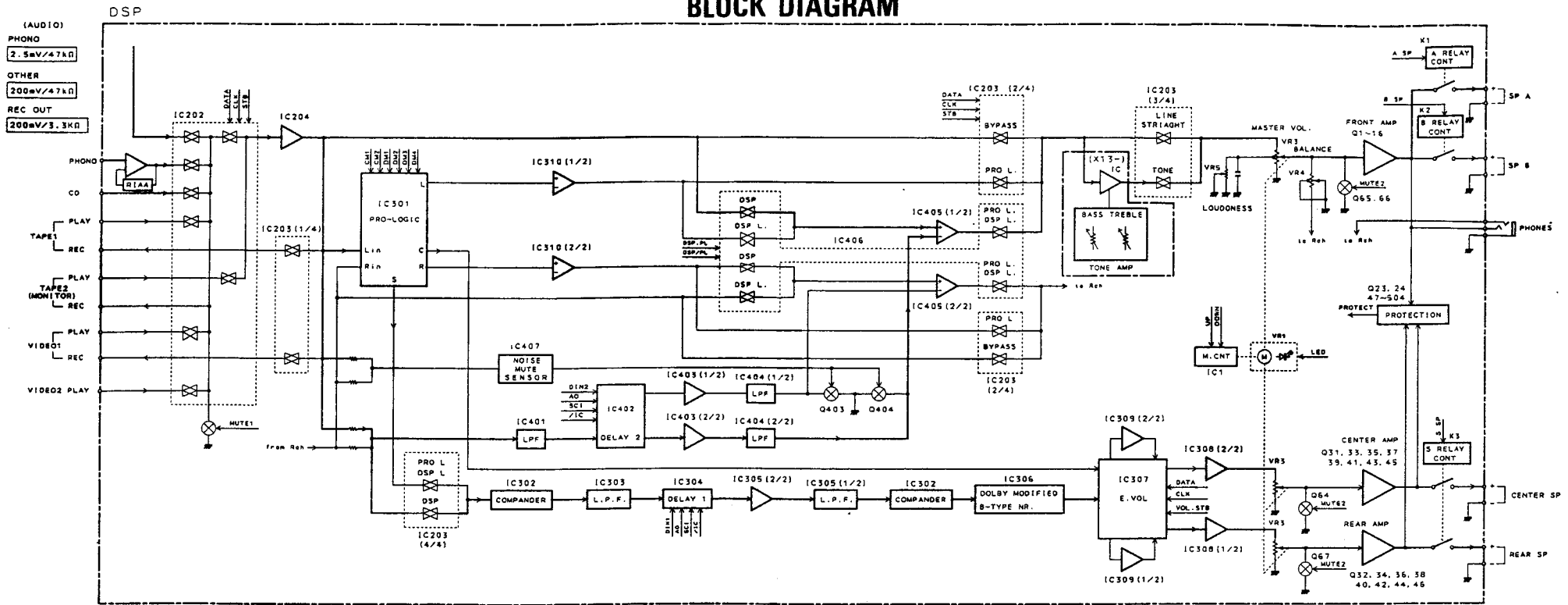

BYPASS (LINE STRAIGHT)

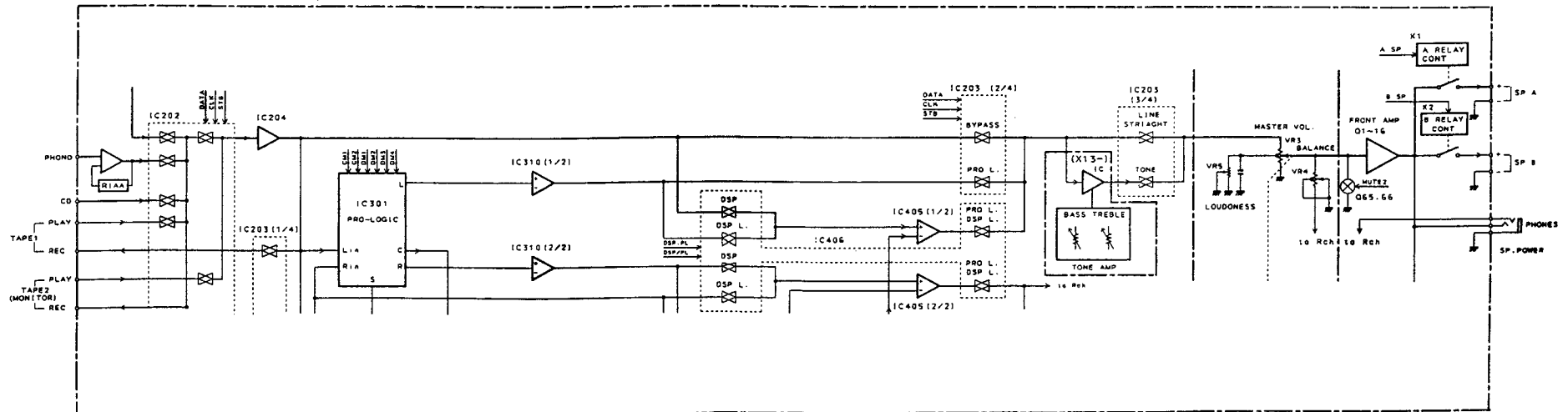

KR-V6050/7050

CIRCUIT DESCRIPTION

1. Function description

Features

AMP

Seven-position selector: (CD, TUNER, PHONO, TAPE1, TAPE2, VIDEO1, VIDEO2/LD)

Six audio input terminals: (CD, PHONO, TAPE1, TAPE2, VIDEO1, VIDEO2/LD)

Three audio output terminals: (TAPE1, TAPE2, VIDEO1)

Two video output terminals: (VIDEO1, VIDEO2/LD)

One video output terminal: (VIDEO1)

LINE STRAIGHT

SURROUND mode.

DSP [KR-V7050]

(ARENA, JAZZ CLUB, STADIUM DISCOTIQUE)

DSP-LOGIC [KR-V7050]

(3ch LARGE THEATER, 3ch SMALL THEATER, 4ch LARGE THEATER, 4ch SMALL THEATER)

PRO-LOGIC, [KR-V6050 (without E TYPE)/V7050]
(NORMAL, WIDE, PHANTOM)

3-STEREO [KR-V6050 (without E TYPE)/V7050]
(NORMAL, WIDE)

Speaker A/B changeover.

Surround memory (M1 to M4). [Without KR-V6050 E type]

(Surround mode, center mode, delay time, center level, rear level, presence level)

TAPE 2 monitor.

TUNER

20ch random preset.

Tuning control by IF count.

Direct selection.

RDS function (E, T-TYPE only).

2. Conditions according to the destination and model

AMP

MODEL	DIODE SW		Surround function
	5	4	
KR-V7050	0	0	PRO-LOGIC, 3-STEREO, DSP, DSP-LOGIC
KR-V6050 (except E)	0	1	PRO-LOGIC, 3-STEREO
KR-V6050 (E only)	1	X	No surround

X: Don't Care

TUNER

Destination	DIODE SW				Band	Receiving Remarks	Channel Space	IF	RF	Note
	3	2	1	0						
K1	0	0	0	0	FM	87.5 MHz ~ 108.0 MHz	100 kHz	+ 10.7 MHz	50 kHz	
					AM	530 kHz ~ 1610 kHz	10 kHz	+ 450 kHz	10 kHz	
K2	0	0	1	0	FM	87.5 MHz ~ 108.0 MHz	100 kHz	+ 10.7 MHz	50 kHz	
					AM	530 kHz ~ 1700 kHz	10 kHz	+ 450 kHz	10 kHz	
E	0	1	0	0	FM	87.5 MHz ~ 108.0 MHz	50 kHz	+ 10.7 MHz	50 kHz	
					AM	531 kHz ~ 1602 kHz	9 kHz	+ 450 kHz	9 kHz	
E	1	1	0	0	FM	87.5 MHz ~ 108.0 MHz	50 kHz	+ 10.7 MHz	50 kHz	With RDS
					AM	531 kHz ~ 1602 kHz	9 kHz	+ 450 kHz	9 kHz	

[DIODE MATRIX: <X14> DIODE SW NO.]

μ -com	PIN NO.	55	56	57	58	59	60
	PIN NO.	KR5	KR4	KR3	KR2	KR1	KR0
61	KS7	Channel space	AM 1610/1700	RDS No/Yes	DSP. DOL/DOL ONLY	SURROUND Yes/No	(X)
DUIDE SW NO.		2	1	3	4	5	0
<X13> DIODE Ref. No.		D32	D31	D33	D34	D35	—

KR-V6050/7050

CIRCUIT DESCRIPTION

- Diode SW 0 →
- Diode SW 1 → AM band range/K TYPE only
0: AM NARROW
1: AM WIDE
- Diode SW 2 → Channel base (Products bound for M: Changeover with switch)
0: FM 100 kHz/step, AM 10 kHz/step
1: FM 50 kHz/step, AM 9 kHz/step
- Diode SW 3 → With/without RDS/E TYPE only
0: Without RDS
1: With RDS
- Diode SW 4 → Surround mode
0: DOLBY function & DSP function
1: DOLBY function only
- Diode SW 5 → With/without surround
0: With surround
1: Without surround

3. Initial state

For Service Manuals Contact
MAURITRON TECHNICAL SERVICES
 8 Cherry Tree Rd, Chinnor
 Oxon OX9 4QY
 Tel: 01844-351694 Fax: 01844-352554
 Email: enquiries@mauritron.co.uk

- ① POWER OFF
 - ② AMP system
 - Audio selector TUNER
 - Video system selector VIDEO1
 - Speaker A ON
 - Speaker B OFF
 - TAPE2 MONITOR OFF
 - LINE STRAIGHT OFF
 - ③ TUNER system
 - Band FM
 - Frequency Lower limit of FM (87,5 MHz)
 - TUNING mode AUTO TUNING (AUTO STEREO)
 - P. CH indication --ch
 - ④ SURROUND system
 - Mode BYPASS (OFF)
 - CENTER LEVEL 0 dB
 - REAR LEVEL 0 dB
 - ⑤ Test frequency
- PROLOGIC mode NORMAL
 - 3STEREO mode NORMAL
 - DSP mode ARENA
 - DSPLOGIC mode SMALL THEATER
 - DSPLOGIC channel mode 3ch
 - PRESENCE LEVEL:
 - DOLBY PROLOGIC, 3STEREO - 20 dB
 - DSP ARENA, JAZZ - 12 dB
 - STADIUM, DISCO - 8 dB
 - DSPLOGIC SMALL THEATER - 16 dB
 - LARGE THEATER - 8 dB
 - DELAY TIME:
 - DOLBY PROLOGIC 20 ms
 - DSP ARENA 10 ms
 - JAZZ 16 ms
 - STADIUM 26 ms
 - DISCO 16 ms
 - DSPLOGIC SMALL THEATER 16 ms
 - LARGE THEATER 32 ms

	K1 TYPE		K2 TYPE		E TYPE	
01ch	FM	98.00 MHz	FM	98.00 MHz	FM	98.00 MHz
02ch	FM	108.00 MHz	FM	108.00 MHz	FM	108.00 MHz
03ch	AM	630 kHz	AM	630 kHz	AM	630 kHz
04ch	AM	990 kHz	AM	990 kHz	AM	990 kHz
05ch	AM	1440 kHz	AM	1440 kHz	AM	1440 kHz
06ch	AM	1610 kHz	AM	1700 kHz	AM	1602 kHz
07ch	FM	87.50 MHz	FM	87.50 MHz	FM	87.50 MHz
08ch	FM	98.50 MHz	FM	98.50 MHz	FM	98.50 MHz
09ch	AM	530 kHz	AM	530 kHz	AM	531 kHz
10ch	FM	89.10 MHz	FM	89.10 MHz	FM	89.10 MHz
11ch	FM	87.50 MHz	FM	87.50 MHz	FM	87.50 MHz
12ch	FM	87.50 MHz	FM	87.50 MHz	FM	87.50 MHz
13ch	FM	87.50 MHz	FM	87.50 MHz	FM	87.50 MHz
14ch	FM	87.50 MHz	FM	87.50 MHz	FM	87.50 MHz
15ch	FM	87.50 MHz	FM	87.50 MHz	FM	87.50 MHz
16ch	FM	87.50 MHz	FM	87.50 MHz	FM	87.50 MHz
17ch	FM	87.50 MHz	FM	87.50 MHz	FM	87.50 MHz
18ch	FM	87.50 MHz	FM	87.50 MHz	FM	87.50 MHz
19ch	FM	87.50 MHz	FM	87.50 MHz	FM	87.50 MHz
20ch	FM	87.50 MHz	FM	87.50 MHz	FM	87.50 MHz

20 (Initial setting)

Insert the AC power cord plug in The electrical outlet while pushing the "POWER" key.

KR-V6050/7050

CIRCUIT DESCRIPTION

4. Test mode

Main unit test mode

1) Setting method

Turn the AC power ON while pushing the "TUNING DOWN" key.

2) Cancellation method

Turn the AC power OFF.

3) Contents

① Start of the main unit test mode

The operation gets in the test mode through a main unit key, when the AC power is turned ON while pushing the "TUNING DOWN" key. Three operations are carried out in this case.

- Automatic power ON
- All fluorescent character display tubes and LED light up
- Initialization of all states except POWER ON/OFF
The "all indications lit up" state is canceled by pushing any key of the main unit. The states changed during the test mode are initialized when the main unit test mode is canceled (AC power OFF).

② Automatic motor VR UP/DOWN (AMP)

The (16-second UP → 16-second DOWN → Stop) operation of the motor VR is carried out when the "TAPE 2" key is operated.

Therefore, "TAPE 2 MONITOR" can not be changed over during the main unit test mode.

③ MUTE signal output (AMP)

No control of selector MUTE (MUTE 1) is carried out.

④ Test mode operation of 0~9, +10 (TUNER)

a) When the +10 key is not operated, the channels 1 to 9 (keys 1 to 9), as well as the channel 10 (key 0) can be called.

b) When the key +10 is operated once, the channels 11 to 19 (keys 1 to 9) as well as the channel 20 (key 0), can be called.

c) When the +10 key is operated once again, the operation returns to the case "a) When the +10 key is not operated".

⑤ Processing of keys available only in the remote controller

a) Processing related to the AMP: None

b) Processing related to the TUNER: None

c) Processing related to the SURROUND (Depends on the SURROUND: MODE)

"P. CH CALL" key: Works in the same way as the "CENTER MODE" key.

"DIRECT" key: Works in the same way as the "TEST TONE" key.

Of course, the operations of "P. CH CALL" and "DIRECT" can not be carried out.

⑥ Cancellation of the main unit test mode

The test mode is canceled, and the operation returns to the initial state when the AC power is turned OFF during the test mode.

KR-V6050/7050

CIRCUIT DESCRIPTION

Timing Chart

① POWER ON

POWER (13)
/MUTE1 (53)
/MUTE2 (12)
VMUTE < x 14 > IC205 (22)

SEL IC (9, 10, 54)
Electrical VOL IC (9, 10, 46)
VIDEO SEL < x 14 > IC205 (21)
SPEAKER RELAY (14 ~ 16)
FL DRIVE (1 ~ 7, 61 ~ 80)
LED DRIVE (18)
Serial communication (41, 42)
PLL IC (9 ~ 11)

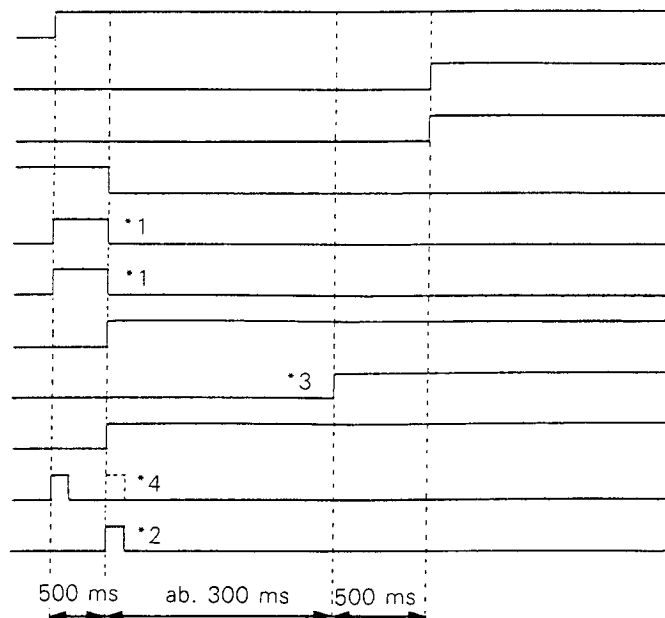

*1. Output of data to the selector IC and the electronic VOL. IC is continued during the time t1 to prevent unstable state of the IC. Moreover, resistors are connected without fail in series with the control lines of the selector IC and the electronic volume IC.

*2. This signal is outputted when the forcible MONO control signal of the TUNER is outputted from the port of the PLL IC (receiver).

*3. Protection detection is started immediately before connecting the SPEAKER RELAY.

*4. The SYSTEM ON code is outputted after the time t1 in the case of single item as well as system component AMP. and RECEIVER.

For Service Manuals Contact
MAURITRON TECHNICAL SERVICES
8 Cherry Tree Rd, Chinnor
Oxon OX9 4QY
Tel:- 01844-351694 Fax:- 01844-352554
Email:- enquiries@mauritron.co.uk

KR-V6050/7050

CIRCUIT DESCRIPTION

② POWER OFF

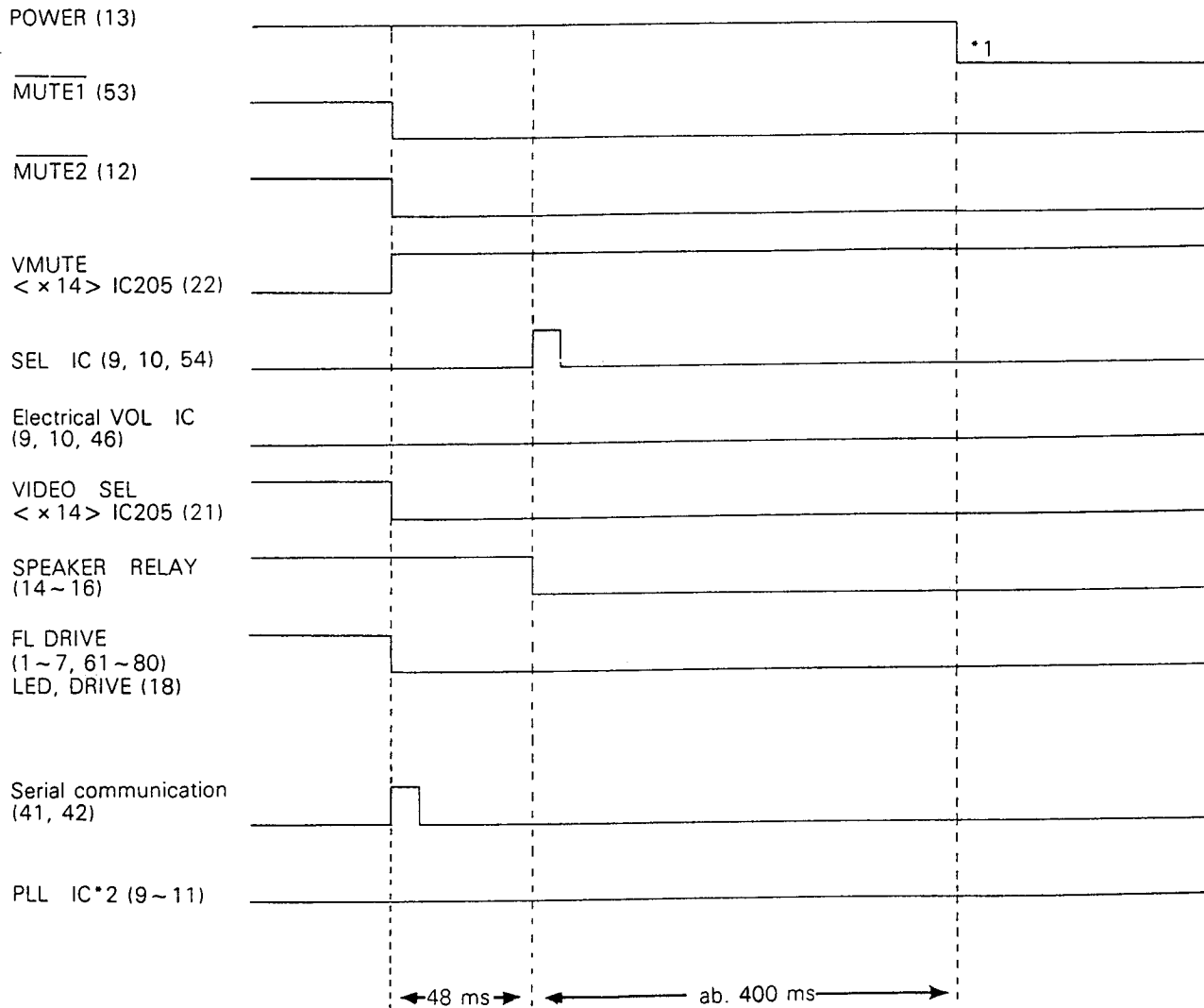

*1. The disconnection of the AC OUTLET is delayed to drop the mechanism of the DECK connected to the AC OUTLET (SWITCHED).

*2. This signal is outputted in the case of receiver.

KR-V6050/7050

CIRCUIT DESCRIPTION

③ Selector changeover

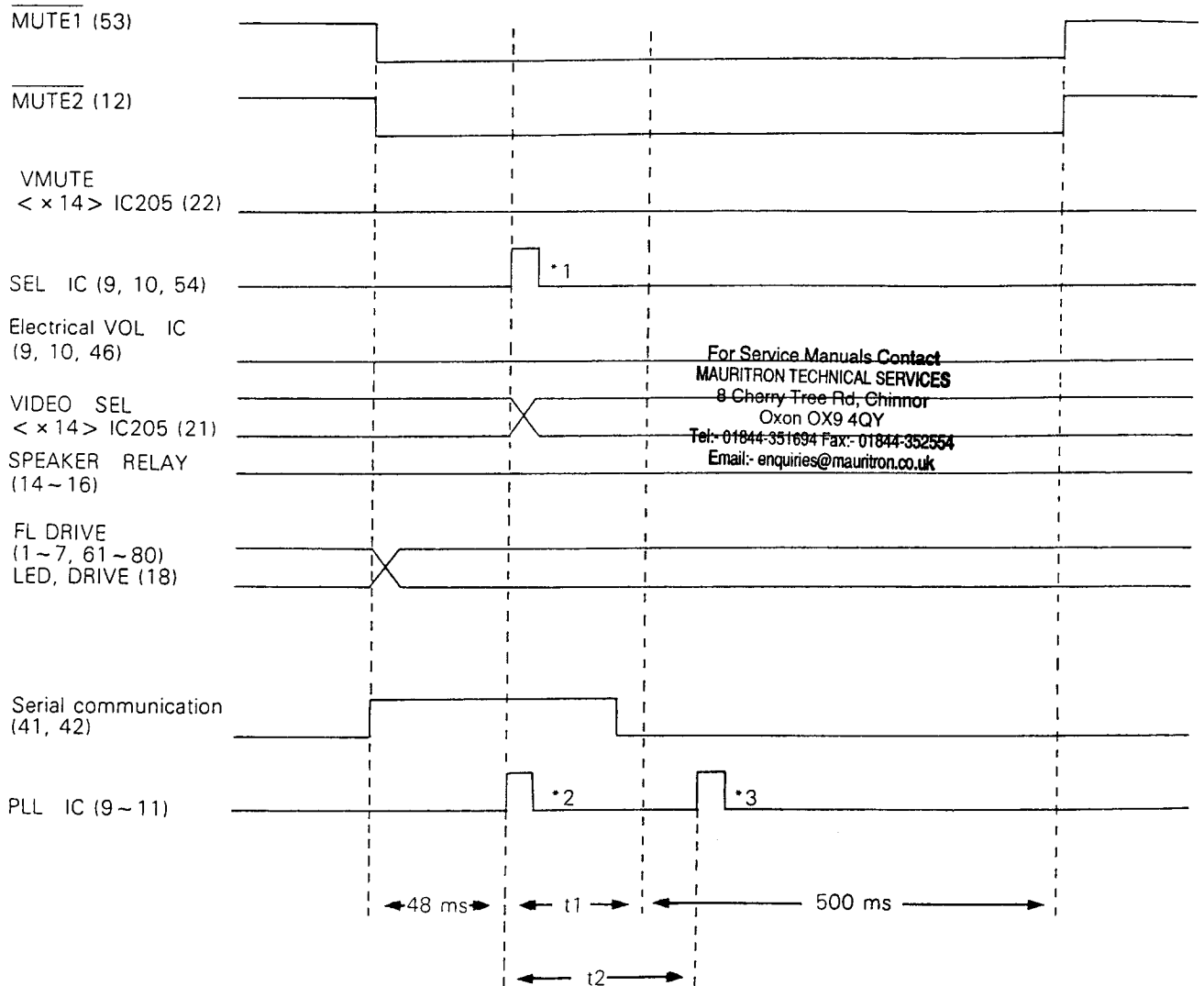

t1: Data transmission time to the selector IC, DSP IC, etc.

t2: 80 ms (+ 80 ms) IF COUNT time

*1. Pay special attention to the oscillation when switching. In particular, before switching the input selector, make sure of opening the REC OUT SW once.

Since data before changeover are left in the RAM for DELAY when the surround is composed by using DSP IC and the like, data of the current surround mode are sent once again to the DSP IC and the like after clearing the RAM for DELAY.

*2. Receivers without TUNER MUTE set the lower frequency limit of AM in the PLL IC, except when the selector is set to TUNER.

*3. The IF count completion data is set with this timing when IF count is being carried out.

KR-V6050/7050

CIRCUIT DESCRIPTION

⑦ SURROUND ON and SURROUND MODE switching CENTER MODE switching

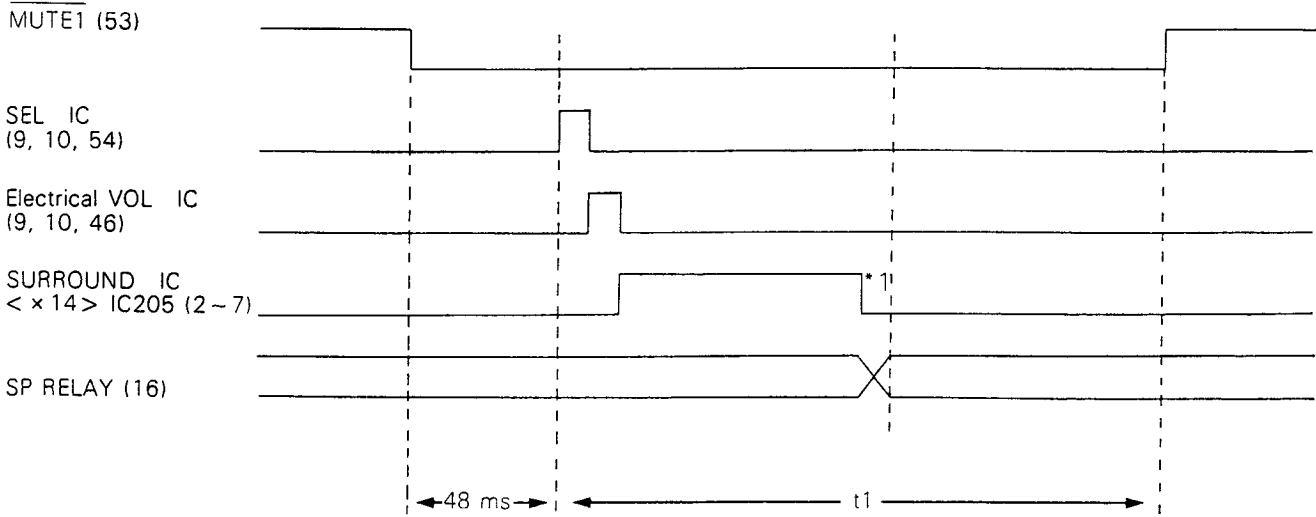

t1: 1000 ms (Including time for transmission of data do selector IC, electronic VOL IC and SURROUND IC).

*1: Since data before changeover are left in the RAM for DELAY when the surround is composed by using DSP IC and the like, data of the current surround mode are sent once again to the DSP IC and the like after clearing the RAM for DELAY

⑧ SURROUND OFF (BYPASS)

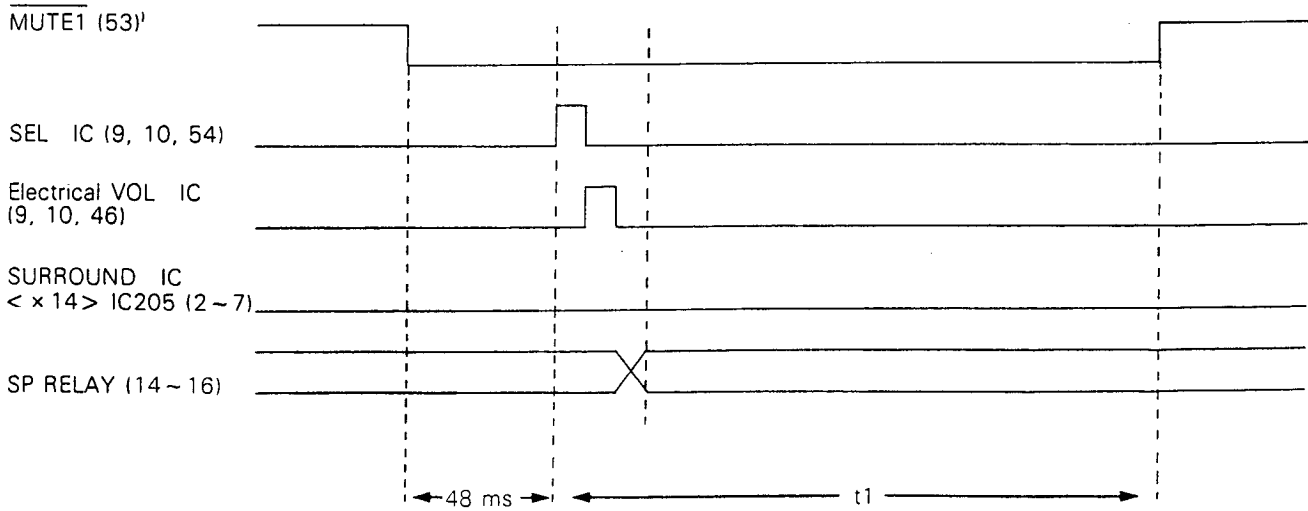

t1: 1000 ms (Including time for transmission of data do selector IC and electronic VOL IC).

KR-V6050/7050

CIRCUIT DESCRIPTION

⑰ AF SEARCH

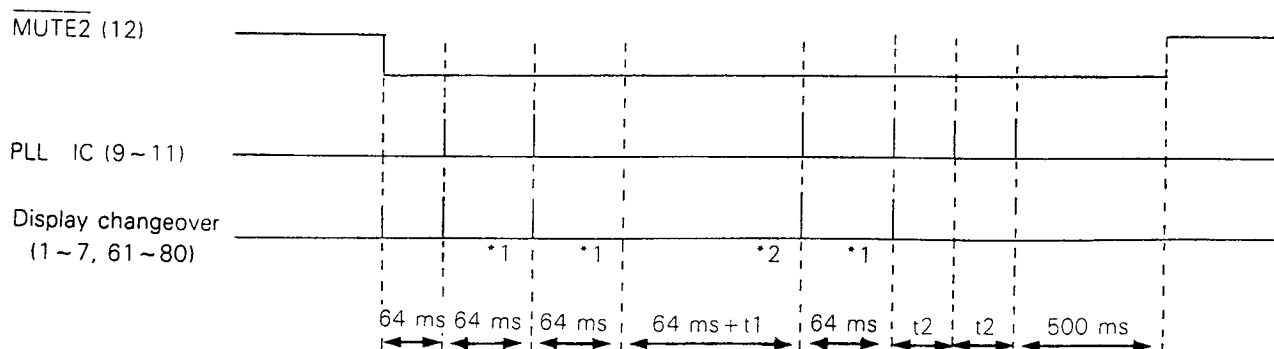

- t1: 560 ms (RDS CHECK)
- t2: 80 ms (Once or twice/IF count time)
- *1: When SD = High (Without station)
- *2: When SD = Low (With station)

For Service Manuals Contact
MAURITRON TECHNICAL SERVICES
 8 Cherry Tree Rd, Chinnor
 Oxon OX9 4QY
 Tel:- 01844-351694 Fax:- 01844-352554
 Email:- enquiries@mauritron.co.uk

⑱ PTY SEARCH

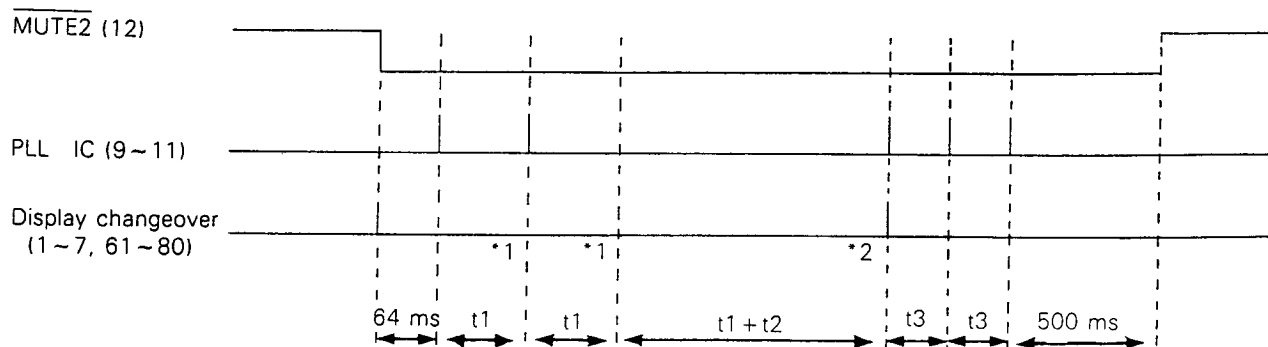

- t1: 32 ms (BAND EDGE = 64 ms)
- t2: 480 mS + 240 mS (RDS CHECK)
- t3: 80 ms (Once or twice/IF count time)
- *1: When SD = High (Without station)
- *2: When SD = Low (With station)

KR-V6050/7050

CIRCUIT DESCRIPTION

Microprocessor: μ PD78044GF-021 (X13: IC1)

μ Com port layout

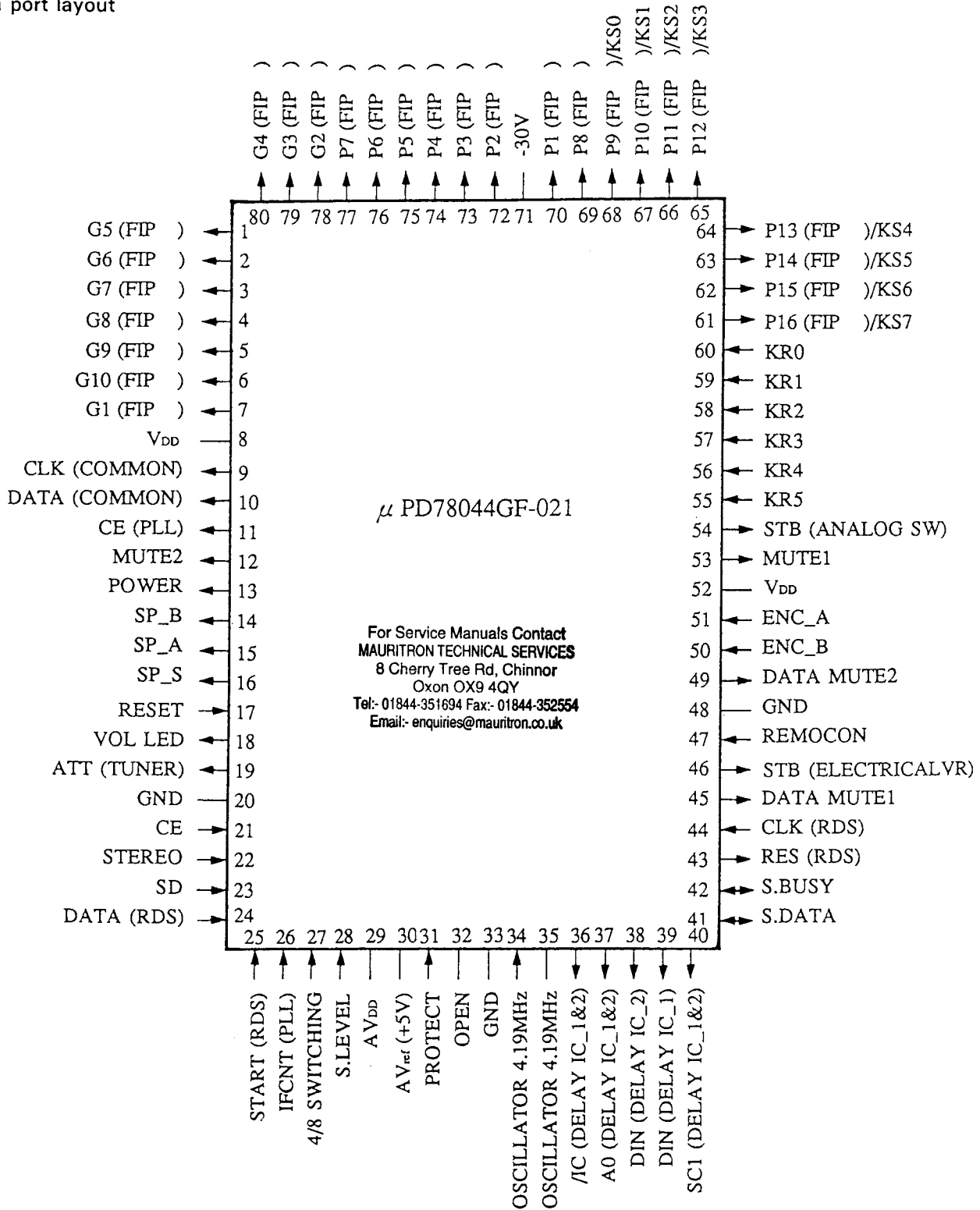

KR-V6050/7050

CIRCUIT DESCRIPTION

Microprocessor periphery block Diagram

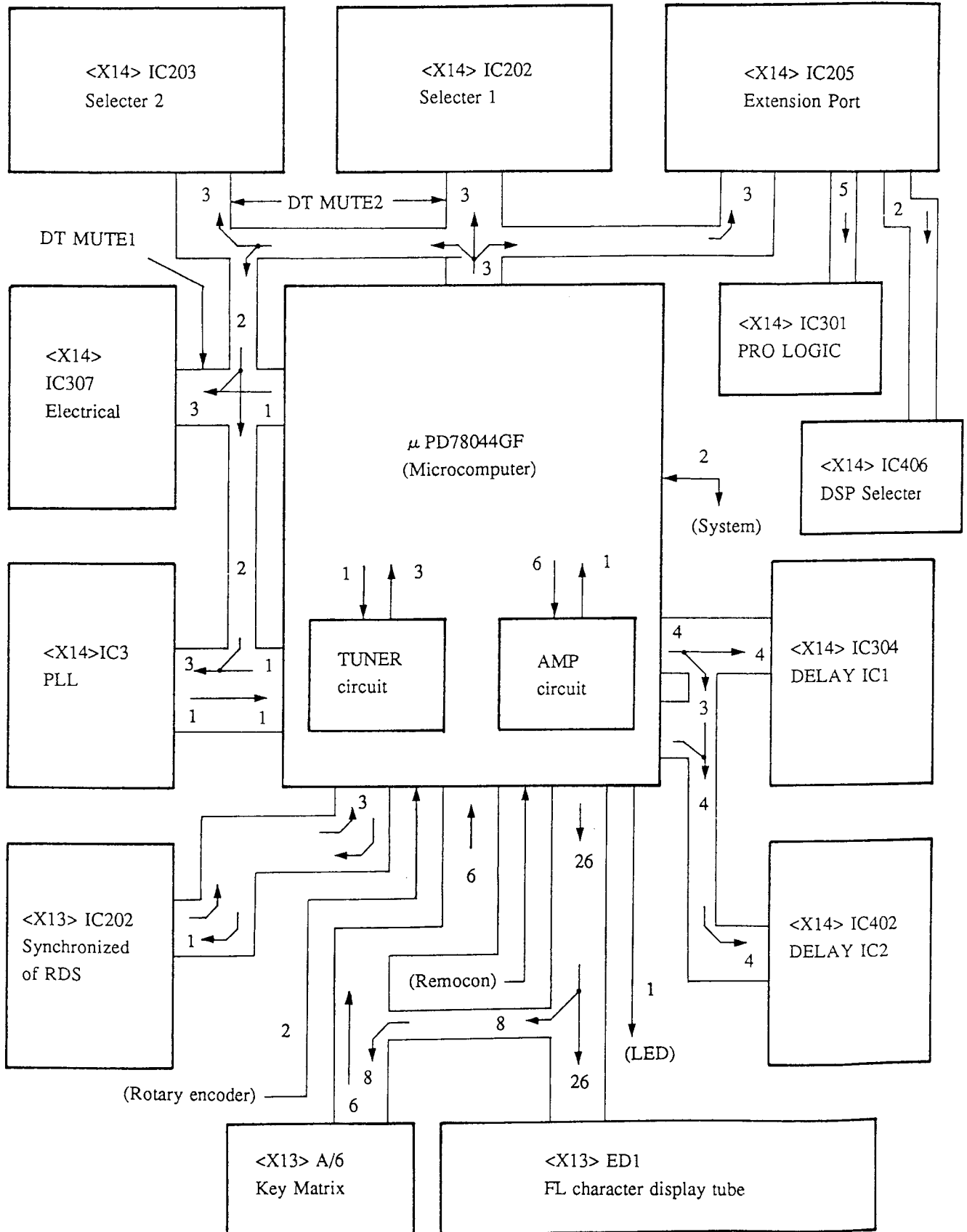

KR-V6050/7050

CIRCUIT DESCRIPTION

Pin description

Pin Number	Port I/O	Name	Description
1	OUT	G5	FL grid 5
2	OUT	G6	FL grid 6
3	OUT	G7	FL grid 7
4	OUT	G8	FL grid 8
5	OUT	G9	FL grid 9
6	OUT	G10	FL grid 10
7	OUT	G1	FL grid 1
8	—	V _{DD}	Microprocessor power supply
9	OUT	CLK (COMMON)	Clock for control IC (ANALOG SW/PLL IC/Electronic VOL)
10	OUT	DATA (COMMON)	Data for control IC (ANALOG SW/PLL IC/Electronic VOL)
11	OUT	CE (PLL)	PLL CE
12	OUT	MUTE ₂	Amplifier MUTE control H: MUTE OFF L: MUTE ON
13	OUT	POWER	Power relay control H: POWER ON L: POWER OFF
14	OUT	SP_B	Speaker B relay control H: SP_B ON L: SP_B OFF
15	OUT	SP_A	Speaker A relay control H: SP_A ON L: SP_A OFF
16	OUT	SP_S	Surround speaker relay control H: SP_S ON L: SP_S OFF
17	IN	RESET	Microprocessor reset
18	OUT	VOL LED	VOLUME LED control H: LED OFF L: LED ON
19	OUT	ATT (TUNER)	Attenuator control H: ATT ON L: ATT OFF
20	—	GND	A/D power supply
21	IN	CE	Microprocessor CE
22	IN	STEREO	Stereo signal detection H: MONAURAL L: STEREO
23	IN	SD	Tuning signal detection H: NOT TUNED L: TUNED
24	IN	DATA (RDS)	RDS data
25	IN	START (RDS)	RDS start bit
26	IN	IFCNT (PLL)	IF CNT data (PLL DO)
27	IN	4/8 Changeover	Speaker impedance switching H: 4 Ω L: 8 Ω
28	IN	S. LEVEL	SIGNAL level (A/D)
29	—	AV _{DD}	A/D power supply
30	—	AV _{ref}	A/D reference voltage (+ 5 V)
31	IN	PROTECTION	Protection detection H: PROTECTION L: NORMAL
32	—	OPEN	
33	—	V _{SS} (GND)	Microprocessor power supply
34	IN	X1	4.19 MHz oscillator
35	OUT	X2	4.19 MHz oscillator
36	OUT	/IC (DELAY 1 & 2)	DELAY IC 1 & 2 initial clearing
37	OUT	A0 (DELAY 1 & 2)	DELAY IC 1 & 2 address/data
38	OUT	DIN (DELAY 1)	DELAY IC 1 data
39	OUT	DIN (DELAY 2)	DELAY IC 2 data
40	OUT	SC1 (DEALY 1 & 2)	DELAY IC 1 & 2 clock

KR-V6050/7050

CIRCUIT DESCRIPTION

Pin Number	Port I/O	Name	Description
41	I/O	S. DATA	8 bit system DATA
42	I/O	S. BUSY	8 bit system BUSY
43	OUT	$\overline{\text{RESET}}$ (RDS)	RDS reset
44	IN	CLK (RDS)	RDS clock
45	OUT	DT MUTE 1	Data MUTE 1 H: DATA MUTE ON L: DATA MUTE OFF
46	OUT	STB (Electrical VOL)	Electronic VOL STB
47	IN	REMOCON	Remote controller input
48	—	GND	
49	OUT	DT MUTE 2	Data MUTE 2 H: DATA MUTE ON L: DATA MUTE OFF
50	IN	ENC_B	Encoder input B
51	IN	ENC_A	Encoder input A
52	—	V _{DD}	Microprocessor power supply
53	OUT	$\overline{\text{MUTE}}$ 1	Selector MUTE control H: MUTE OFF L: MUTE ON
54	OUT	STB (ANALOG SW)	Analog SW STB
55	IN	KR5	Key return 5
56	IN	KR4	Key return 4
57	IN	KR3	Key return 3
58	IN	KR2	Key return 2
59	IN	KR1	Key return 1
60	IN	KR0	Key return 0
61	OUT	P16/KS7	FL segment 16/Key scan 7
62	OUT	P15/KS6	FL segment 15/Key scan 6
63	OUT	P14/KS5	FL segment 14/Key scan 5
64	OUT	P13/KS4	FL segment 13/Key scan 4
65	OUT	P12/KS3	FL segment 12/Key scan 3
66	OUT	P11/KS2	FL segment 11/Key scan 2
67	OUT	P10/KS1	FL segment 10/Key scan 1
68	OUT	P9/KS0	FL segment 9/Key scan 0
69	OUT	P8	FL segment 8
70	OUT	P1	FL segment 1
71	—	-30 V (Vload)	FL drive power supply
72	OUT	P2	FL segment 2
73	OUT	P3	FL segment 3
74	OUT	P4	FL segment 4
75	OUT	P5	FL segment 5
76	OUT	P6	FL segment 6
77	OUT	P7	FL segment 7
78	OUT	G2	FL grid 2
79	OUT	G3	FL grid 3
80	OUT	G4	FL grid 4

KR-V6050/7050

CIRCUIT DESCRIPTION

RDS product operation (KR-V6050/7050: E, T type)

1. Outline of RDS

RDS (RADIO DATA SYSTEM) is a new FM broadcasting feature which is being carried out in the 87.5–108.0 MHz FM broadcasting frequency band. RDS consists of broadcasting digital signals on the sub-carrier (57 kHz) of the FM signal, and the digital signal is on the upper part of the MAIN and SUB (STEREO) carriers of the ordinary FM broadcasting. Therefore, it exerts no influence on the sound of the FM broadcasting. Since RDS broadcasting has the major purpose of providing service covering movable receivers, its functions extend over a wide range, but it does not have so much applications related to ordinary audio tuners for home use.

RDS broadcasting was originated in Europe, and as things now stand it is not available in other areas.

2. Basic functions of RDS

As things now stand, 14 basic functions of RDS have been made public, and there is possibility of addition of new functions in the future. The 14 functions are listed in the followings.

- ① PI (Program Identification)
- ② PS (Program Service)
- ③ PTY (Program TYPe)
- ④ TP (Identification of Traffic Program)
- ⑤ AF (Alternative Frequency List)
- ⑥ TA (Identification of Traffic Announcement)
- ⑦ DI (Decoder Identification)
- ⑧ M/S (Music/Speech Switch)
- ⑨ PIN (Program Item)
- ⑩ RT (Character Broadcasting)
- ⑪ EON (Information on Other Networks)
- ⑫ TDC (Transparent Data Channel)
- ⑬ IH (In House Application)
- ⑭ CT (Clock Time and Date)

It is presumed that most of these functions target movable receivers.

The receivers announced this time (KR-V6050/V7050) use five functions, ①, ②, ③, ⑤ and ⑭.

3. RDS data format

RDS data are transmitted continuously in by arranging them in units (groups) of 104 bits. Each 104-bit data unit (group) consists of 4 blocks, and each block consists of 26 bits of data. Each 26-bit data block consists of 16-bit information word and 10-bit check word. The construction of the data group and data blocks are shown below.

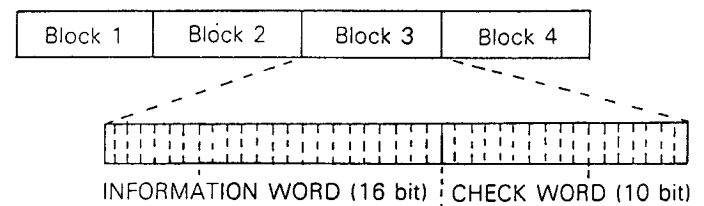

Since the 10-bit check word is the data for error detection, its detailed description is omitted. The 16-bit information word is the data to realize the RDS functions.

① Block 1

This 16-bit data represents the PI code. In all groups, block 1 is the PI (identification) code of the broadcasting station carrying out RDS broadcasting.

② Block 2

This 16-bit data contains information of various kinds. The most basic information is the group type code (4-bit), and indicates the type of the group which the block in question is contained in. Moreover, there is also the Bo code (1 bit) which indicates the version of the group. The type of the group becomes clear from this 5-bit data. Thus, there are basically 32 types of groups consisting of XA and XB (X = 0 to 15). Block 2 of all groups contains this code.

Another basic data is the TP data (1 bit) and the PTY data (5 bit), where TP is the traffic program identification code and PTY is the type code of the broadcasting program. Also these data are contained in Block 2 of all groups.

The remaining 5 bits have different uses, depending on the group type code.

③ Block 3

Block 3 has different uses, depending on the group type code. It must be remembered, however, that the same contents as Block 1 (PI code) are sent in the case of group type XB (X = 0 to 15).

For Service Manuals Contact
MAURITRON TECHNICAL SERVICES
8 Cherry Tree Rd, Chinnor
Oxon OX9 4QY
Tel:- 01844-351694 Fax:- 01844-352554
Email:- enquiries@mauritron.co.uk

KR-V6050/7050

CIRCUIT DESCRIPTION

④ Block 4

Block 4 has different uses, depending on the group type code.

As can be seen, the use of the last 5 bits of Block 2 and the use of data of Block 3 and Block 4 depends of the group type data of the first 5 bits of Block 2.

4. Description of the functions of RDS

Only the following RDS functions used in the receivers KR-V6050/7050 (hereinafter KR-V) featuring RDS.

1. PI (Program Identification)
2. PS (Program Service)
3. PTY (Program Type)
4. AF (List of Alternative Frequencies)
5. CT (Clock time and Date)

4-1. PI (Program Identification) function

As mentioned previously in "3. RDS Data Format", PI code is contained in all groups, and therefore data determination does not take so much time.

The PI code is an important data because it is the broadcasting station identification code, but the PI code itself does not realize any function. This time the PI code is used to determine the synchronization of RDS and to check the coincidence of the broadcasting station during AF search (described later on).

4-2. PS (Program Service) function

In the case of Groups Type 0A and Type 0B, PS data consists of the last 2 bits of Block 2 and the totality of Block 4 (2 bytes). Since PS data has (8-column × 1 BYTE) composition, it is necessary to read at least 4 times from 0A to 0B until reading all columns, and the determination of data requires relatively long time. Moreover, the indication requires some time to change over, because it changes over after the entry of all columns and the determination of the data.

The PS function indicates the broadcasting station name, and the indication mode is switched to the PS indication mode when RDS broadcasting is received and the PS indication mode when RDS broadcasting is received and the PS data is determined.

The indication mode has the following order of priority:

- ① PS indication
- ② SNPS indication
- ③ Frequency indication

PS indication appears on the display when the PS data is determined, the SNPS indication appears on the display when there is no PS and there is SNPS data, and the frequency is indicated when there is no PS nor SNPS. This time the DISPLAY key is not used to switch the indication mode, and is used to confirm the contents indicated on the display in each case, instead. The PS indication, the SNPS indication, the frequency indication and the CT indication are switched cyclically, but the display returns to the original state after 5 seconds. When there is no PS data, there is no PS indication on the display even when PS indication is requested by the DISPLAY key (the display does not get in the PS indication mode).

As mentioned above, the determination of the PS data requires some time, and therefore it is impossible to carry out PS indication immediately after changing the frequency. Such being the case, frequency indication is carried out during 3 seconds after changing the frequency.

4-3. PTY (Program Type) function

Since PTY data is contained in all groups, in the same way as PI data, it does not take so much time for data determination. Basically, time required for data determination is the same as in the case of PI or slightly longer.

PTY is the function which identifies the type of program being broadcasted, and consists of 5-bit data. Therefore, it is possible to have 32 types, but as things now stand only 17 types have been defined (Refer to the attached sheets). This data can be used to carry out the "PTY search", which consists of searching for the broadcast the user wants to listen to.

PTY search requires a series of operations, that consist of getting in the PTY selection mode by means of the PTY key, selecting the desired PTY by means of the UP/DOWN key and the ten keys (0 to 9), and starting the search by means of the +10 key. The mode is canceled when no key is operated within 5 seconds.

The search operation increases the frequency in steps of 100 kHz, and stops at the broadcasting station which coincides with the selected PTY. If the selected PTY is not found even when the frequency scans through the whole broadcasting band, the search operation is finished. The "NO PROG" indication is displayed for 5 seconds when the broadcasting station of the type being searched is not found.

KR-V6050/7050

CIRCUIT DESCRIPTION

If RDS broadcasting is being received when the PTY key is pushed in the first place, the current PTY is displayed, and the selection processing is carried out at that point. PTY search can be carried out even when the station being received is not broadcasting RDS (even when no station is being received). In this case the first PTY indication is "NONE" (same as PTY = 0).

4-4 AF (Alternative Frequency List) function

AF data consist of 2-byte data of Block 3 in the case of group type OA. Since each AF data consists of 1 byte 2 AF data are transmitted each time.

AF data refer to the alternative frequency of the station which is being broadcasted. If the AF list is prepared by gathering these data, it becomes possible to search and find another station with receiving conditions that are better than the current ones from that list, when the receiving conditions of the station which is being received becomes bad. This is the concept of "AF search".

AF search is the function to find, from the existing AF list, another broadcasting station which has receiving conditions that are better than the current ones. If the broadcasting station which is being received is an RDS broadcasting station (station carrying out RDS broadcasting), search is started when the AF key is pushed. No search is carried out, however, when there is no AF list.

In the search operation the current frequency, PI code, S (signal) level, and N (noise) level are stored in the first place as best data, and then the frequency data of the AF list are scanned. When a station is found the PI code is checked for coincidence, and if the PI coincides the receiving states (S-level, N-level) are compared. The best receiving conditions are regarded as the best data, and the best values (No. 1) and better values (No. 2) are fetched. Search operation is carried out up to the last station of the AF list, and when the whole AF list is searched, the best receiving station is determined out of the surviving best data and better data. Details are shown in the attached flowchart.

There are 2 methods to transmit the AF data, and they are called "Method A" and "Method B". They have minor differences in the order of transmission of alternative frequency data. In "Method A" alternative frequency data of a maximum of 25 stations are transmitted in succession. In "Method B" either of the pair of alternative frequencies (2 frequencies) being transmitted contains the same data as the pair transmitted next. In "Method B" the transmitted data have the following meanings, depending on how they are transmitted.

(PATTERN 1): The TUNING frequency is the data composing the pair, and we have $f1 < f2$.

f1	f2
88.1 MHz	90.0 MHz

 (90.0 MHz is being received)

90.0 MHz	101.0 MHz
----------	-----------

In this case both 88.1 MHz and 101.0 MHz stations have the same PI, and these data are fetched in the AF list. Therefore, these frequencies are submitted to AF search.

(PATTERN 2): The TUNING frequency is the data composing the pair, and we have $f1 > f2$.

f1	f2
91.0 MHz	89.0 MHz

 (91.0 MHz is being received)

93.7 MHz	91.0 MHz
----------	----------

In this case the 89.0 MHz and 93.7 MHz stations have different PI (local broadcasting), and these data are not fetched in the AF list. Therefore, these frequencies are not submitted to AF search.

(PATTERN 3): The TUNING frequency is not the data composing the pair.

f1	f2
93.4 MHz	91.0 MHz

 (91.0 MHz is being received)

100.7 MHz	93.4 MHz
-----------	----------

Since in this case the main station (91.0 MHz) outputs the AF list for the 93.4 MHz substation, this AF list is not the AF (alternative frequency) of the station that is being received. It is the data for the substation without RDS broadcasting facilities. Therefore, no AF search is carried out with these frequencies.

For Service Manuals Contact
MAURITRON TECHNICAL SERVICES
8 Cherry Tree Rd, Chinnor
Oxon OX9 4QY
Tel:- 01844-351694 Fax:- 01844-352554
Email:- enquiries@mauritron.co.uk

KR-V6050/7050

CIRCUIT DESCRIPTION

4-5. CT (clock time and date) functions

The CT (clock) function transmits the current year/month/day as well as minute/second as RDS data.

The feature being used this time decodes only the hour and minute. CT data are transmitted once every minute. Therefore, misreading of a code may result into serious misindication on the display. As a countermeasure to cope with that problem, clock count is carried out inside the microcomputer concurrently with the fetching of the CT data. When CT data is not received for 5 minutes or one, clock count is stopped.

When CT data is entered correctly 3 successive times, clock count is started inside the microprocessor and indication of the clock on the display becomes possible. After

that, the clock counter inside the microprocessor is corrected when CT data is received, and the clock counter inside the microcomputer is advanced by 1 minute when no CT data is received after the passage of 1 minute. Since ceramic clock is used instead of crystal oscillator in the receiver microprocessor being used this time, there is possibility of error of a few seconds when it is counted during 5 minutes with no correction. Therefore, when no CT data is received for 5 minutes, the clock data is cleared and the clock count by the microprocessor is stopped.

The clock indication is changed over by means of the DISPLAY key, but the indication returns to the original state after 5 seconds. There is no CT indication when there is no clock data and when no RDS broadcasting is being received.

APPENDIX

PTY Data Table

No.	PTY Code	Programme Type	PTY Display	Ten Key	UP/DOWN
0	00	No programme type or undefined	NONE	—	—
1	10	Pop music	POP M	1	○
2	11	Rock music	ROCK M	2	○
3	12	M.O.R. music	M.O.R. M	3	○
4	13	Light classical	LIGHT M	4	○
5	14	Serious classical	CLASSICS	5	○
6	15	Other music	OTHER M	6	○
7	01	News	NEWS	7	○
8	02	Current Affairs	AFFAIRS	8	○
9	03	Information	INFO	9	○
10	04	Sport	SPORT	0	○
11	05	Education	EDUCATE	—	○
12	06	Drama	DRAMA	—	○
13	07	Culture	CULTURE	—	○
14	08	Science	SCIENCE	—	○
15	09	Varied	VARIED	—	○
16-30	16-30	Not yet assigned	NONE	—	—
31	31	Alarm	ALARM	—	—

For Service Manuals Contact
MAURITRON TECHNICAL SERVICES
 8 Cherry Tree Rd, Chinnor
 Oxon OX9 4QY
 Tel: 01844-351694 Fax: 01844-352554
 Email: enquiries@mauritron.co.uk

KR-V6050/7050

CIRCUIT DESCRIPTION

Dolby Pro-Logic Surround Matrix Decoder: SSM-2126 (X14: IC301)

FEATURES

- Noise Generator and Autobalance Circuits are Contained On-Chip
- Autobalance On/Off Control
- 4-Channel Pro-Logic and Dolby 3 (Surround Channel Defeat) Modes Available
- Selectable Center Channel Modes—Normal, Wide-band, Phantom, Off
- Direct Path Bypass (Normal 2-Channel Stereo Mode)
- Wide Channel Separation

- Any Channel to Another—25 dB min
- Wide Dynamic Range—103 dB typ
- Low Total Harmonic Distortion—0.02% typ
- Available in a 48-Pin Plastic DIP
- CMOS and TTL Compatible Control Logic

APPLICATIONS

- Direct View and Projection TV
- Integrated A/V Amplifiers
- Laserdisc and CD-V Players
- Video Cassette Recorders
- Stand-Alone Surround Decoders
- Home Satellite Receiver/Descramblers

FUNCTIONAL BLOCK DIAGRAM

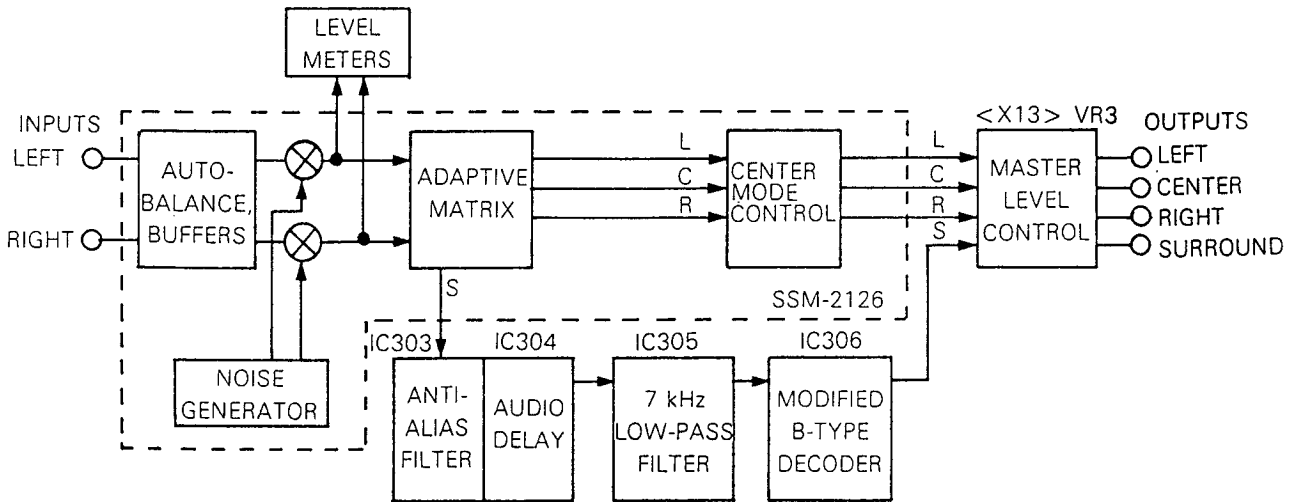

* Dolby is a registered trademark of Dolby Laboratories Corporation, San Francisco, California.

PIN CONNECTIONS

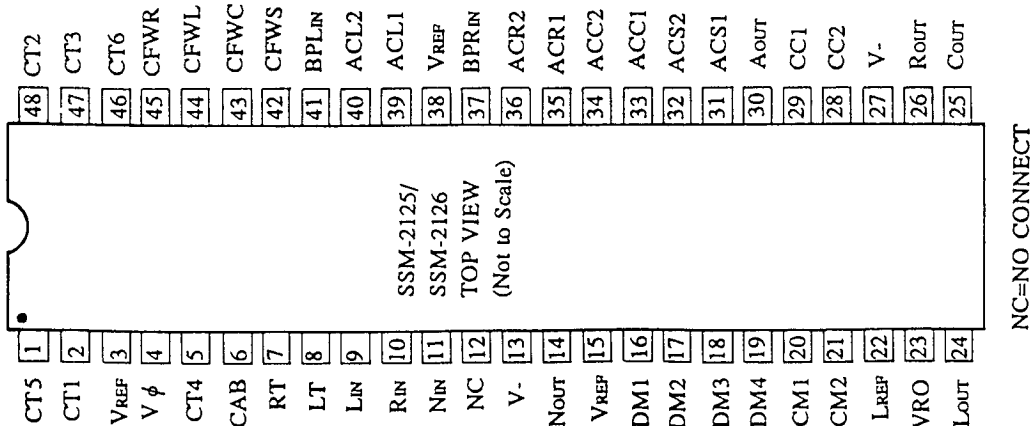

KR-V6050/7050

CIRCUIT DESCRIPTION

PIN DESCRIPTION

Pin Number	Name	Function
1	CT5	Long Time Constant, C/S
2	CT1	Short Time Constant, L/R Comparators
3	V _{REF}	Reference Voltage: Ground or Pseudoground
4	V+	Positive Supply
5	CT4	Short Time Constant, C/S Comparators
6	CAB	Autobalance Time Constant
7	RT	Buffered, Autobalanced Right Channel Signal
8	LT	Buffered, Autobalanced Left Channel Signal
9	L _{IN}	Left Channel Input
10	R _{IN}	Right Channel Input
11	N _{IN}	Filtered Noise Input
12	NC	Do Not Connect
13	V-	Negative Supply (Ground in Single Supply)
14	N _{OUT}	Noise Output
15	V _{REF}	Reference Voltage: Ground or Pseudoground
16	DM1	Digital Operating-Mode Control Input
17	DM2	Digital Operating-Mode Control Input
18	DM3	Digital Operating-Mode Control Input
19	DM4	Digital Operating-Mode Control Input
20	CM1	Digital Center-Mode Control Input
21	CM2	Digital Center-Mode Control Input
22	L _{REF}	Logic Reference Voltage (Threshold = L _{REF} + 1.4 V)
23	VRO	V _{REF} Out—Pseudoground Output
24	L _{OUT}	Left Channel Output
25	C _{OUT}	Center Channel Output
26	R _{OUT}	Right Channel Output
27	V-	Negative Supply (Ground in Single Supply)
28	CC2	Center Normal-Mode Filter Input (Z = 15 kΩ)
29	CC1	Center Normal-Mode Filter Output

Pin Number	Name	Function
30	S _{OUT}	Surround Channel Output
31	ACS1	Surround Channel Steering Signal AC Coupling and High-Pass Filter
32	ACS2	Surround Channel Steering Signal AC Coupling and High-Pass Filter
33	ACC1	Center Channel Steering Signal AC Coupling and High-Pass Filter
34	ACC2	Center Channel Steering Signal AC Coupling and High-Pass Filter
35	ACR1	Right Channel Steering Signal AC Coupling and High-Pass Filter
36	ACR2	Right Channel Steering Signal AC Coupling and High-Pass Filter
37	BPR _{IN}	Filtered Right Channel Input to Steering Signal Generator
38	V _{REF}	Reference Voltage: Ground or Pseudoground
39	ACL1	Left Channel Steering Signal AC Coupling and High-Pass Filter
40	ACL2	Left Channel Steering Signal AC Coupling and High-Pass Filter
41	BPL _{IN}	Filtered Left Channel Input to Steering Signal Generator
42	CFWS	Surround Channel Full-Wave Rectifier Low-Pass Filter
43	CFWC	Center Channel Full-Wave Rectifier Low- Pass Filter
44	CFWL	Left Channel Full-Wave Rectifier Low-Pass Filter
45	CFWR	Right Channel Full-Wave Rectifier Low- Pass Filter
46	CT6	Short Time Constant, C/S
47	CT7	Shot Time Constant, L/R
48	CT2	Long Time Constant, L/R

Control States for DM1 – DM4 (PIN NO. ⑯ ~ ⑲)

DM1	DM2	DM3	DM4	Operating State	Function
1	1	1	1	Dolby + Channel ("Pro-Logic"), Autobalance On	
1	1	0	1	Dolby + Channel ("Pro-Logic"), Autobalance Off	X
1	0	1	1	Dolby 3-Channel ("Dolby 3"), Autobalance On	
1	0	0	1	Dolby 3-Channel ("Dolby 3"), Autobalance Off	X
0	1	1	1	Surround Channel Noise	
0	1	1	0	Right Channel Noise	
0	1	0	1	Center Channel Noise	
0	1	0	0	Left Channel Noise	
0	0	X	1	Mute	X
0	0	1	0	Stereo Bypass, Auto-balance On	X
0	0	0	0	Stereo Bypass, Auto-balance Off	X

Center Channel Functional Modes (PIN NO. ⑳, ㉑)

CM1	CM2	Mode	Function
0	0	Center Channel Off	X
0	1	Center Channel Wideband	
1	0	Phantom Center Channel	
1	1	Normal Center Mode	

For Service Manuals Contact
MAURITRON TECHNICAL SERVICES
 8 Cherry Tree Rd, Chinnor
 Oxon OX9 4QY
 Tel: 01844-351694 Fax: 01844-352554
 Email: enquiries@mauritron.co.uk

0: L 1: H X: H or L

KR-V6050/7050

CIRCUIT DESCRIPTION

Digital delay IC: YM7128B (X14: IC304, 402)

Si-Gate CMOS PROCESS LSI

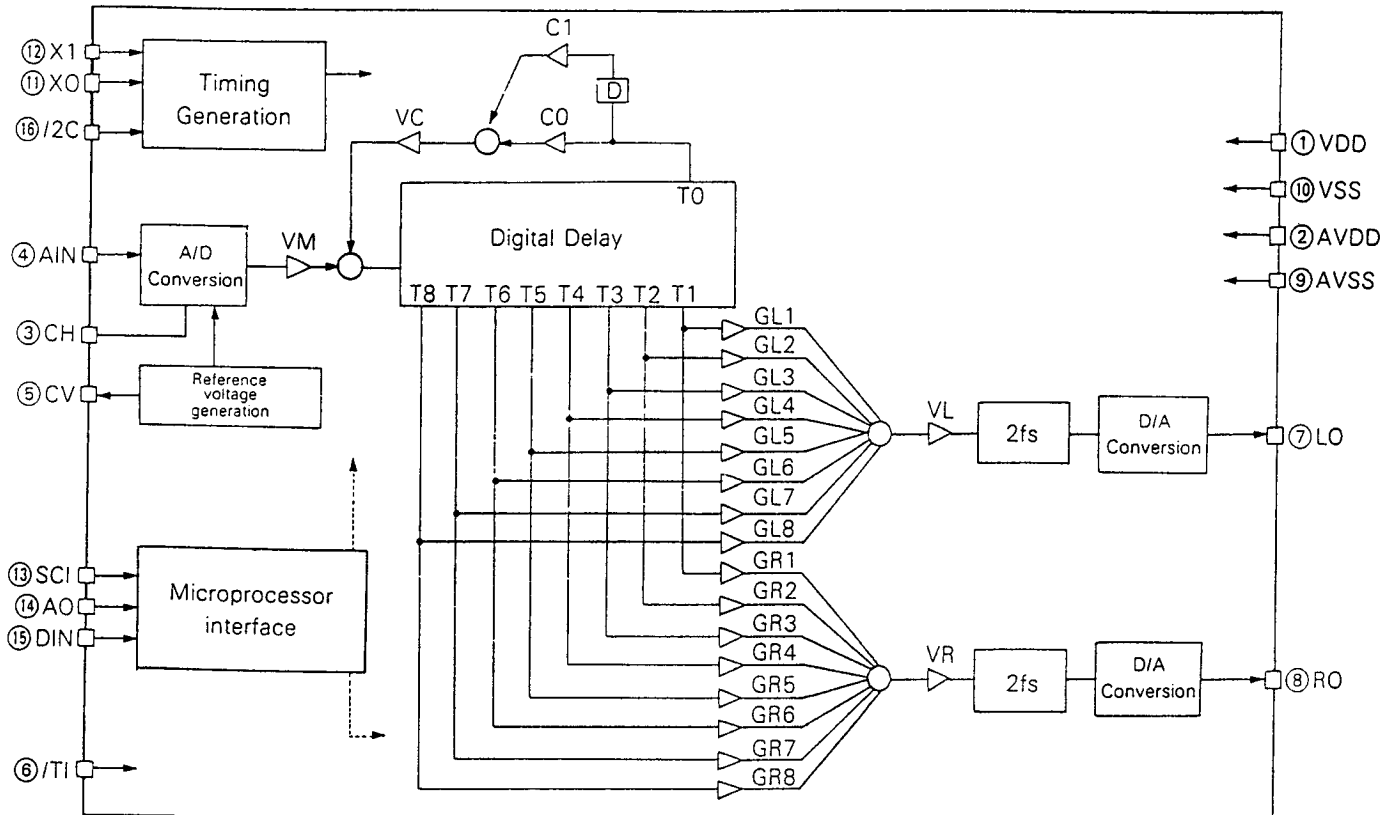

Pin Function description

Pin connection

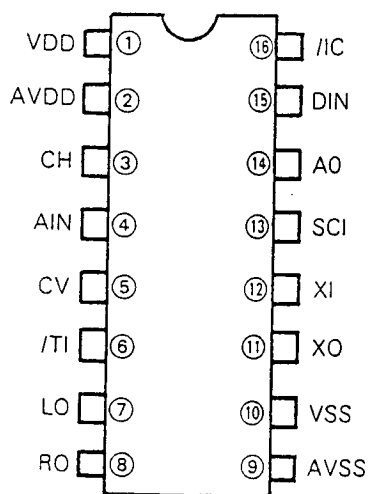

Terminal No.	Terminal name	I/O	Function
1	VDD	—	Digital system +5 V power supply
2	AVDD	—	Analog system +5 V power supply
3	CH	O	Sample holding capacitor add-on terminal
4	AIN	I	Analog signal input terminal (Entered by CV voltage reference).
5	CV	O	A/D conversion reference voltage output
6	/TI	I+	Test input terminal (Normally unconnected)
7	LO	O	L-channel output (Analog output)
8	RO	O	R-channel output (Analog output)
9	AVSS	—	Analog system ground
10	VSS	—	Digital system ground
11	XO	O	Crystal oscillator (standard 7.16 MHz) connection (XI is the analog input terminal when using external clock)
12	XI	I	
13	SCI	I	Data shift clock input terminal
14	AO	I	Address/data identification signal input terminal
15	DIN	I	Data input terminal
16	/IC	I+	Initial clear terminal

Terminals bearing the mark "+" contain built-in pull-up resistor.

KR-V6050/7050

CIRCUIT DESCRIPTION

Video amp. selector: CXA1558L (X09: IC2)

Strong points

- 4-input, 2-output
- Low crosstalk Typ-70 dB
- Two built-in 75-Ohm driver systems with even voltage gain characteristics
- Built-in mute function
- One of the 2 output systems provided with inhibit (mute) function

Construction

- Bipolar monolithic IC

Block diagram and terminal layout diagram

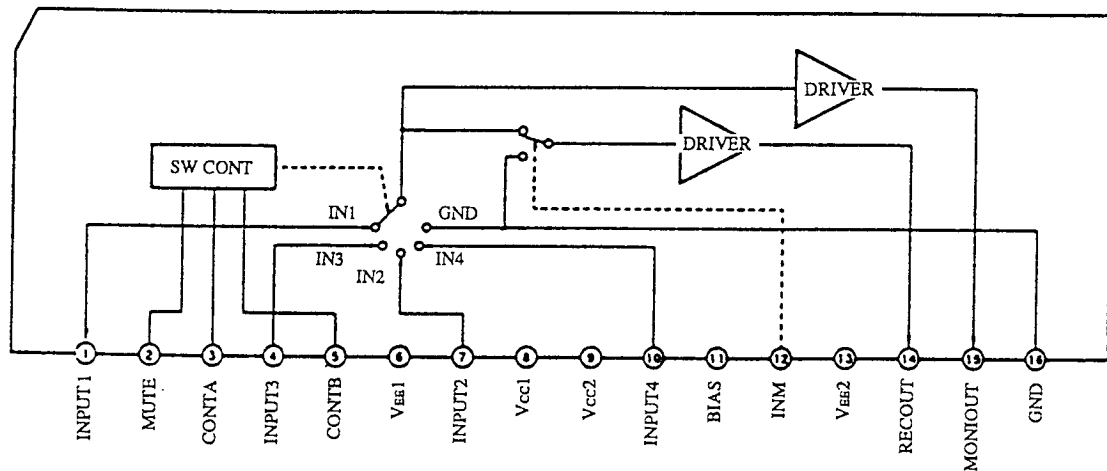

For Service Manuals Contact
MAURITRON TECHNICAL SERVICES
 8 Cherry Tree Rd, Chinnor
 Oxon OX9 4QY
 Tel:- 01844-351694 Fax:- 01844-352554
 Email:- enquiries@mauritron.co.uk

KR-V6050/7050

CIRCUIT DESCRIPTION

Pin Description

Terminal Number	Terminal name	Terminal voltage (V)	Equivalent circuit	Terminal description
1 4 7 10	INPUT1 INPUT3 INPUT2 INPUT4	0		Signal input terminal. The standard input level is 1 V _{p-p} . The input resistance is 40 KΩ each. (Normally, these terminals should be grounded with 75Ω when using).
2	MUTE	$0 \leq L \leq 1.5^*$ $H \geq 3.5^*$		This is the control terminal to mute the input signal. The mute function is canceled when this terminal is stuck to Low. All input signals are muted simultaneously when this terminal is stuck to HIGH. At that time, the output voltages of the terminals (14) and (15) are stuck to the GND potential.
12	INH	$0 \leq L \leq 1.5^*$ $H \geq 3.5^*$		Control terminal for Inhibit to output of (14) pin. The inhibit function is canceled when this terminal is stuck to LOW. The inhibit (mute) operation is carried out when this terminal is stuck to HIGH, and the output voltage of the terminal (14) is stuck to the GND potential.
3 5	CONTA CONTB	$0 \leq L \leq 1.5^*$ $H \geq 3.5^*$		Control terminal for input selection. One out of INPUT1 to INPUT4 is selected through the combination of LOW and HIGH of CONTA and CONTB. (For details refer to the output value list).
6	V _{EE1}	-5*	—	Negative power supply terminal of the switch unit.
8	V _{CC1}	5*	—	Positive power supply terminal of the switch unit
9	V _{CC2}	5*	—	Positive power supply unit of the driver unit.
11	BIAS	0*		This terminal is used by grounding it. (Terminal for IC test).
13	V _{EE2}	-5*	—	Negative power supply terminal of the driver unit.

KR-V6050/7050

CIRCUIT DESCRIPTION

Terminal Number	Terminal name	Terminal voltage (V)	Equivalent circuit	Terminal description
14	RECOUT	0		<p>Signal output terminal. The standard output level is 1 V_{OH} when terminated with 75Ω. The signal selected by the control terminal out of INPUT1 to INPUT4 is outputted. This terminal is outputted the GND potential when the terminal (12) is stuck at HIGH. The 75Ω load can be driven directly.</p>
15	MINIOUT	0		<p>The standard output level is 1 V_{OH} when terminated with 75Ω. The signal selected by the control terminal out of INPUT1 to INPUT4 is outputted. The 75Ω load can be driven directly.</p>
16	GND	0*	—	GND terminal.

For Service Manuals Contact
MAURITRON TECHNICAL SERVICES
 8 Cherry Tree Rd, Chinnor
 Oxon OX9 4QY
 Tel:- 01844-351694 Fax:- 01844-352554
 Email:- enquiries@mauritron.co.uk

* External Input terminal voltage

In/Output value list

Control signal				Output		
CONTA	CONTB	MUTE	INH	RECOUT	MONIOUT	
③ PIN	⑤ PIN	② PIN	⑫ PIN	⑭ PIN	⑮ PIN	
L	L	L	L	Input signal to INPUT1		
L	H			Input signal to INPUT3		
H	L			Input signal to INPUT2		
H	H			Input signal to INPUT4		
•	•	H	H	GND voltage level		
L	L	L		GND voltage level	Input signal to INPUT1	
L	H				Input signal to INPUT3	
H	L				Input signal to INPUT2	
H	H				Input signal to INPUT4	
•	•	H		GND voltage level		

* Don't Care

0 ≡ L ≡ 1.5 V
 H ≡ 3.5 V

KR-V6050/7050

CIRCUIT DESCRIPTION

7. Compressor/Expander IC: NE571N (X14: IC302)

7-1. Analog converter circuit

The S/N ratio is lowered due to the digital delay circuit. To offset this, a noise reduction is applied.

The signal is compressed down to half the dynamic range by the compressor circuit and is passed through a digital delay circuit. After that, it is expanded to twice by the expander circuit to ensure the original dynamic range.

The μ PC1571C is a high-performance integrated circuit capable of constituting a high-precision analog converter by a lesser number of externally connected components.

Incorporated within one package are a reference voltage circuit and a two-fold operation amplifier, gain cell and rectifier.

This IC can be applied to a limiter, a voltage controlled amplifier, an ordinary home-use device noise reduction circuit, etc., including a compandor as in a telephone system.

7-2. Features

- Operation on single power, +6V to +16V
- With built-in identical circuits of 2 channels, a compandor can be formed by one package.
- Dynamic range, approx. 70dB
- Distortion rate adjustable

7-3. Standard transfer characteristics

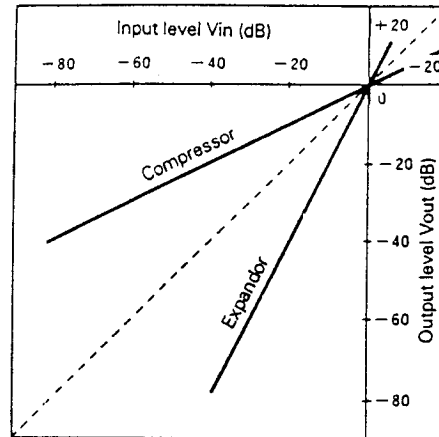

7-4. Standard application circuit example

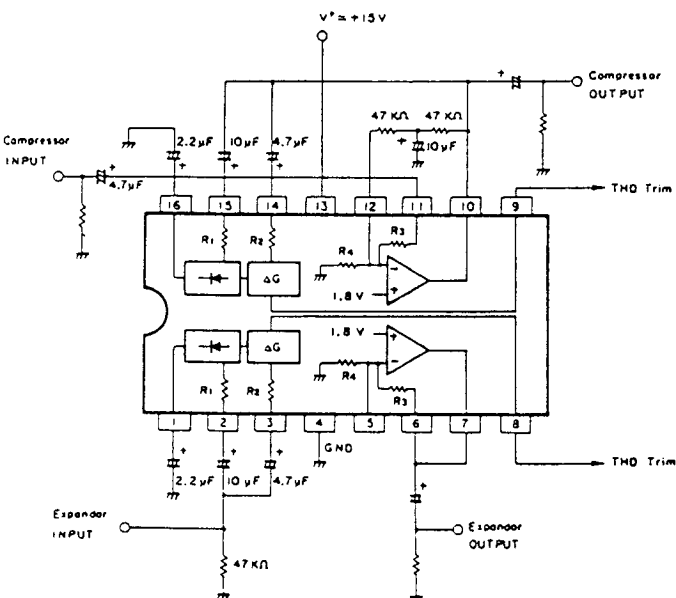

7-5. Description of terminals

Pin No.	Function	Pin No.	Function
1	Rect1	9	THD Trim 2
2	Rect IN 1	10	OUT 2
3	Δ G Cell IN 1	11	R ₃ 2
4	GND	12	I ₁ 2
5	I ₁ 1	13	V _{cc}
6	R ₃ 1	14	Δ G Cell IN 2
7	OUT 1	15	Rect IN 2
8	THD Trim 1	16	Rect2

KR-V6050/7050

CIRCUIT DESCRIPTION

7-6. Compressor application circuit example

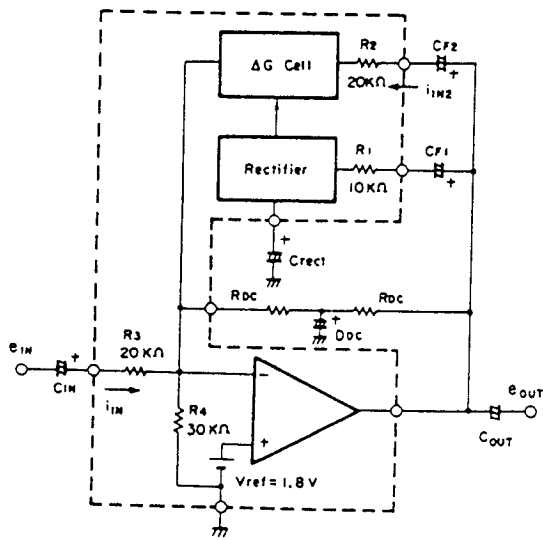

7-7. Operation as an expander

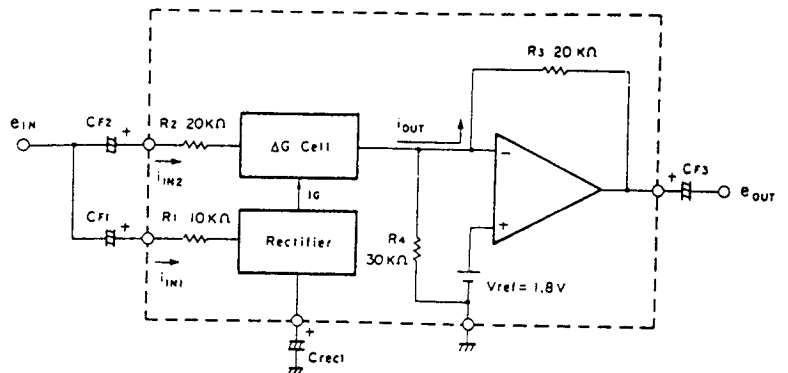

For Service Manuals Contact
MAURITRON TECHNICAL SERVICES
 8 Cherry Tree Rd, Chinnor
 Oxon OX9 4QY
 Tel:- 01844-351694 Fax:- 01844-352554
 Email:- enquiries@mauritron.co.uk

7-8. Theoretical values of head room and noise level with compressor/expander circuit

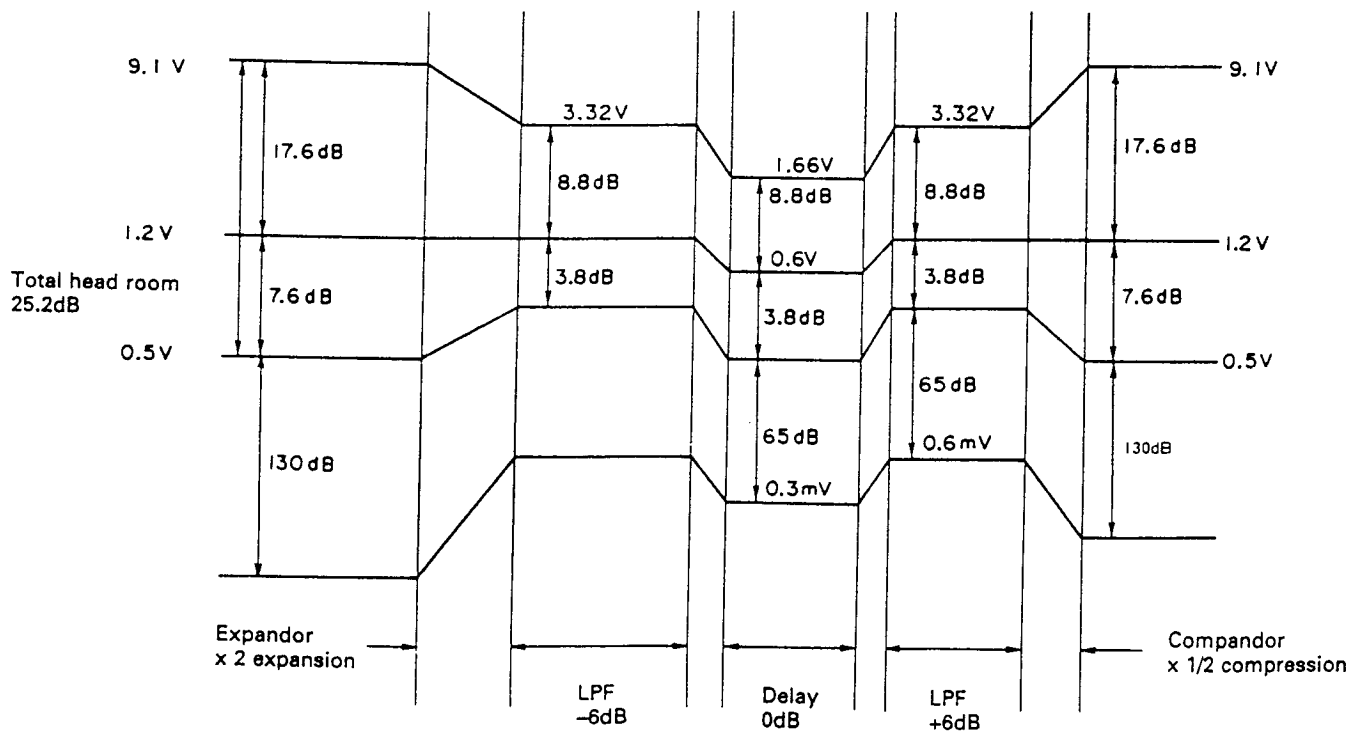

KR-V6050/7050

ADJUSTMENT

AM. Section: If alignment point is "--", Confirm the value.
If not. Replace the front end pack.

No.	ITEM	INPUT SETTINGS	OUTPUT SETTINGS	TUNER SETTINGS	ALIGNMENT POINTS	ALIGN FOR	FIG.
FM SECTION		SELECTOR: FM					
1	DISCRIMINATOR	(A) 98.0 MHz 1 kHz, ± 75 kHz dev 60 dB μ (ANT input)	Connect a DC voltmeter between TP3 and TP4. (XI 3-)	AUTO or MONO 98.0 MHz	L2 (X14-)	0 V	(a)
2	DISTURTION (MONO) <T.E type only>	(C) 98.0 MHz 1 kHz, ± 68.25 MHz dev Selector: L or R Pilot: ± 6.75 kHz dev 60 dB μ (ANT input)	(B)	98.0 MHz	L9 (X14-)	Minimum distortion	
3	DISTORTION (STEREO)	(C) 98.0 MHz 1 kHz, ± 68.25 kHz dev Selector: L or R Pilot: ± 6.75 kHz dev 60 dB μ (ANT input)	(B)	98.0 MHz	IFT (X02-)	Minimum distortion. (L or R)	
4	SEPARATION	(C) 98.0 MHz Stereo signal 60 dB (ANT input)	(B)	AUTO 98.0 MHz	VR5 (X14-)	Minimum crosstalk	
5	TUNING LEVEL	(A) 98.0 MHz 0 dev 19 dB μ (ANT input) 75 μ	(B)	AUTO or MONO 98.0 MHz	VR1 (X14-)	Adjust VR1 and stop at the point where ED1 (TUNED) goes on.	
AM SECTION		SELECTOR: AM					
(1)	TUNING LEVEL	(D) 1000 (999) kHz 26 dB μ (ANT input)	(B)	—	VR3 (X14-)	Adjust VR2 and stop at the point where ED1 (TUNED) goes on.	
AUDIO SECTION							
<1>	IDLE CURRENT	--	(E) Connect a DC voltmeter across CP1 (L) CP2 (R) CP3 (C) (X09-)	Volume: 0	VR1 (L) VR2 (R) VR3 (C) (X09-)	10 mV (L, R) 5 mV (C)	(b)

KR-V6050/7050

REGLAGE

Section AM: Si le point d'alignement est __, confirmer la valeur.
Sinon, remplacer le bloc avec.

N°.	ITEM	REGLAGE DE L'ENTREE	REGLAGE DE LA SORTIE	REGLAGE DU TUNER	POINT DE L'ALIGNEMENT	ALIGNER POUR	FIG.
SECTION MF SELECTEUR DES ENTRESS: MF							
1	DISCRIMINATEUR	(A) 98.0 MHz 1kHz, ± 75 kHz dév 60 dB μ (Entrée ANT)	Relier un voltmètre CC entre les TP3 et TP4. (X13-)	AUTO ou MONO 98.0 MHz	L2 (X14-)	0 V	(a)
2	DISCRIMINATEUR (MONO) (T, E Type Seulement)	(c) 98.0 MHz 1 kHz, ± 68.75 MHz dév Selec-tion; L ou R Signal pilote: ± 6.75 kHz dév 68 dB μ (Entrée ANT)	(B)	98.0 MHz	L9 (X14-)	Distorsion minimale.	
3	DISTORSION (STEREO)	(c) 98.0 MHz 1 kHz, ± 68.25 kHz dév Selec-tion: L ou R Signal pilote: ± 6.75 kHz dév 60 dB μ (Entrée ANT)	(B)	98.0 MHz	IFT (X02-)	Distorsion minimale. (L ou R)	
4	SEPARATION	(c) 98.0 MHz STEREO Signal 60 dB μ (Entrée ANT)	(B)	AUTO 98.0 MHz	VR5 (X14-)	Diaphonie minimale.	
5	NIVEAU D'ACCORDER	(A) 98.0 MHz 0 dév - 19 dB μ (Entrée ANT) 75 Ω	(B)	AUTO ou MONO 98.0 MHz	VR1 (X14-)	Ajuster VR1 et arrêter le mouvement de VR1 au moment où le ED1 (TUNED) s'allume.	
SECTION MA SELECTEUR: AM							
(1)	NIVEAU D'ACCORDER	(A) 1000 (999) kHz 26 dB μ (Entrée ANT)	(B)	-	VR3 (X14-)	Ajuster VR2 et le mouvement de VR4 au moment où le ED1 (TUNED) s'allume.	
SECTION AUDIO							
[1]	COURANA DE POLARISATION	-	(E) Connecter un voltmètre CC sur CP1 (L) CP2 (R) CP3 (L) (X09-)	Volume: 0	VR1 (L) VR2 (R) VR3 (L) (X09-)	10 mV (L, R) 5 mV (C)	(b)

For Service Manuals Contact
MAURITRON TECHNICAL SERVICES
8 Cherry Tree Rd, Chinnor
Oxon OX9 4QY
Tel:- 01844-351694 Fax:- 01844-352554
Email:- enquiries@mauritron.co.uk

KR-V6050/7050

ABGLEICH

MW-Teil: Wenn der Ausrichtpunkt — ist, den Wert überprüfen.
Wenn nicht, die Fronteinheit auswechseln.

NR.	GEGENSTAND	EINGANGS-EINSTELLUNG	AUSGANGS-EINSTELLUNG	TUNER-EINSTELLUNG	ABGLEICH-PUNKTE	ABGLEICHEN FÜR	ABB.
UKW-EMPFANGSABTEILUNG EINGANGSUMSCHALTER: FM							
1	DISKRI-MINATOR	(A) 98.0 MHz 1 kHz, ± 75 kHz Hub 60 dB μ (ANT-Eingang)	Einen Gleichspannungsmesser zwischen TP3 und TP4 ausschließen (X13-)	AUTO oder MONO 98.0 MHz	L2 (X14-)	0 V	(a)
2	DISKRIMINATOR (2)	(A) 98.0 MHz 1 kHz, ± 75 kHz Hub 60 dB μ (ANT-Eingang)	(B)	MONO 98.0 MHz	T3 (X05-)	Minimal Klirrfaktor.	
3	KLIRRFAKTOR (STEREO)	(c) 98.0 MHz 1 kHz, ± 68.25 kHz Hub Wähler: L oder R Piloten: ± 6.75 kHz Hub 60 dB μ (ANT-Eingang)	(B)	98.0 MHz	Frontende IFT (X05-)	Minimal Klirrfaktor.	
4	STEREO KANAL TRENNUNG	(c) 98.0 MHz 1 kHz, ± 68.25 kHz Hub Wähler: L oder R Piloten: ± 6.75 kHz Hub 60 dB μ (ANT-Eingang)	(B)	98.0 MHz	VR4 (X05-)	Minimales Übersprechen. Eine Ausgleichregelung kann notwendig sein, falls links-zu-rechts und rechts-zu-links. Trennungen ungleich sind.	
5	ABSTIMM PEGEL	(A) 98.0 MHz 0 Hub — 19 dB μ (ANT-Eingang) 75 Ω	(B)	AUTO oder MONO 98.0 MHz	VR1 (X14-)	Den Pegel wiederstand aufdrehen, und dem VR1 Halt geben wobei den ED1 (TUNED) anzeiger leuchtet wird.	
MW-EMPFANGSABTEILUNG Die MW Rahmenantenne angebracht lassen. WAHLER: AM							
(1)	ABSTIMM PEGEL	(A) 1000 (999) kHz 26 dB μ (ANT-Eingang)	(B)	—	VR3 (X14-)	Den Pegel wiederstand aufdrehen und dem VR2 Halt geben wobei den ED1 (TUNED) anzeiger leuchtet wird.	
AUDIO-ABTEILUNG							
[1]	LEER-LAUFSTROM	—	(E) Einen Gleichspannungsmesser über CP1 (L) CP2 (R) anschließen. CP3 (L) (X09-)	Volume: 0	VR1 (L) VR2 (R) VR3 (L) (X09-)	10 mV (L, R) 5 mV (C)	(b)

KR-V6050/7050

ADJUSTMENT/REGLAGE/ABGLEICH

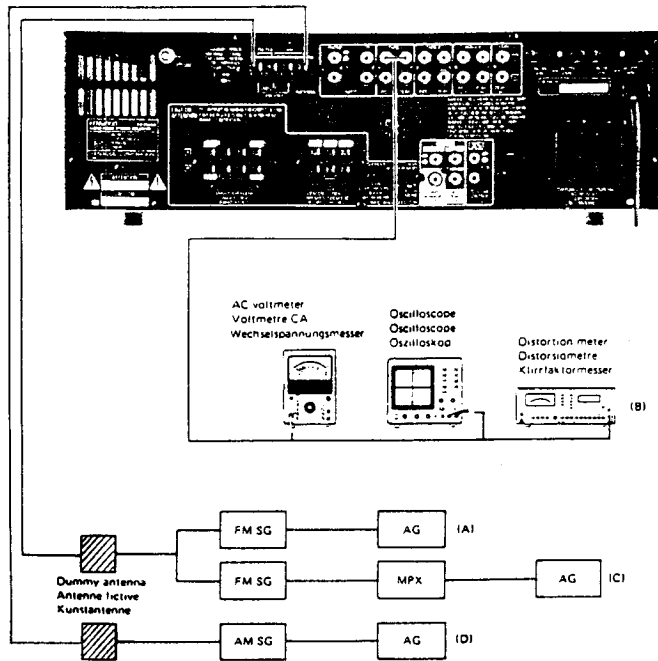

System connections/Raccordements du système/System-Anschlüsse

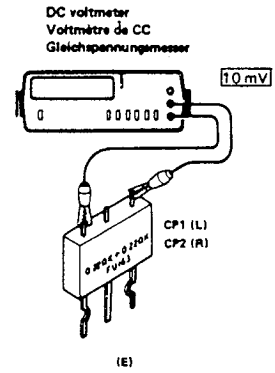

For Service Manuals Contact
MAURITRON TECHNICAL SERVICES
 8 Cherry Tree Rd, Chinnor
 Oxon OX9 4QY
 Tel:- 01844-351694 Fax:- 01844-352554
 Email:- enquiries@mauritron.co.uk

KR-V6050/7050 KR-V6050/7050

WIRING DIAGRAM (KR-V6050)

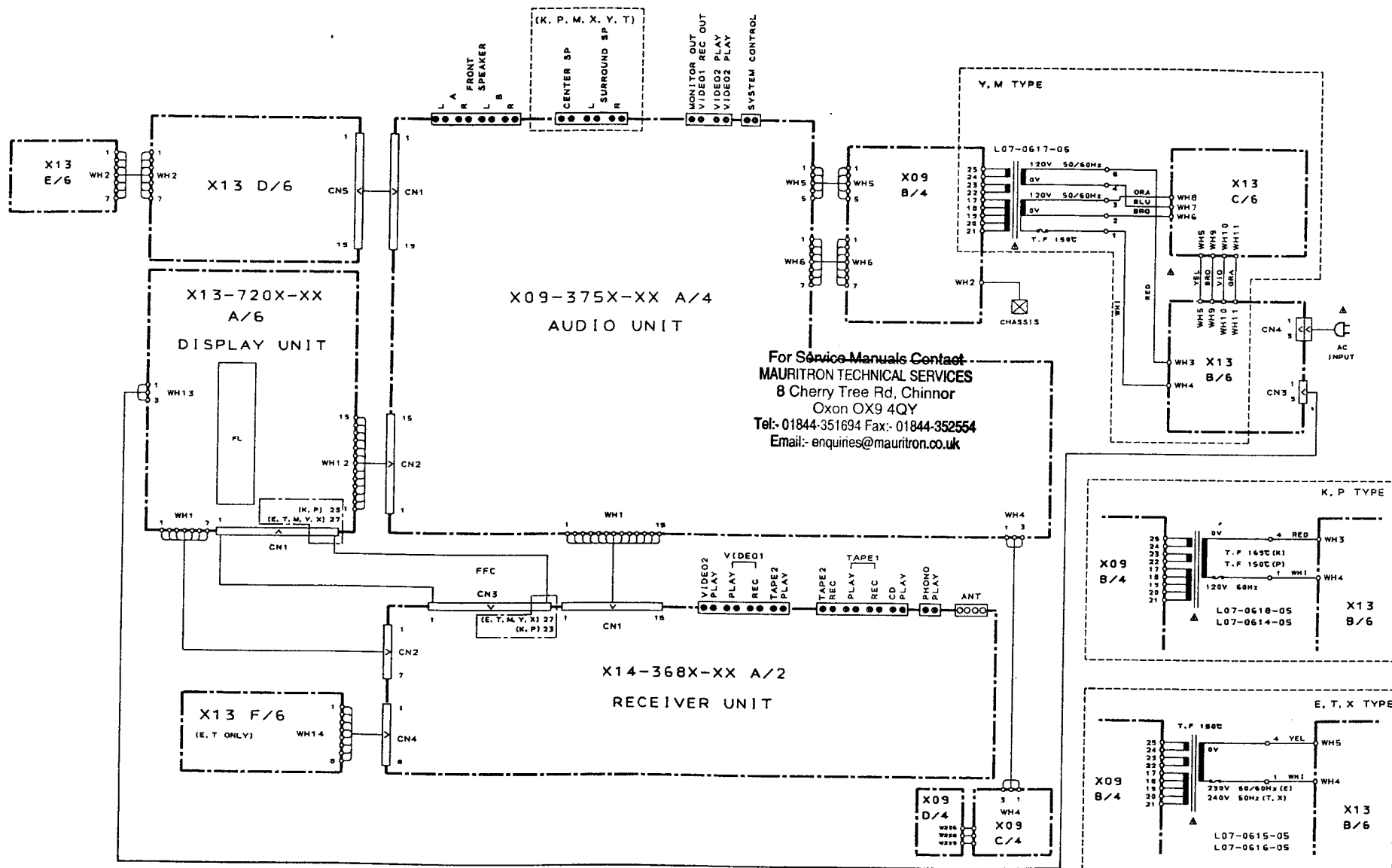

For Service Manuals Contact
MAURITRON TECHNICAL SERVICES
 8 Cherry Tree Rd, Chinnor
 Oxon OX9 4QY
 Tel:- 01844-351694 Fax:- 01844-352554
 Email:- enquires@mauritron.co.uk

KR-V6050/7050 KR-V6050/7050

WIRING DIAGRAM (KR-V7050)

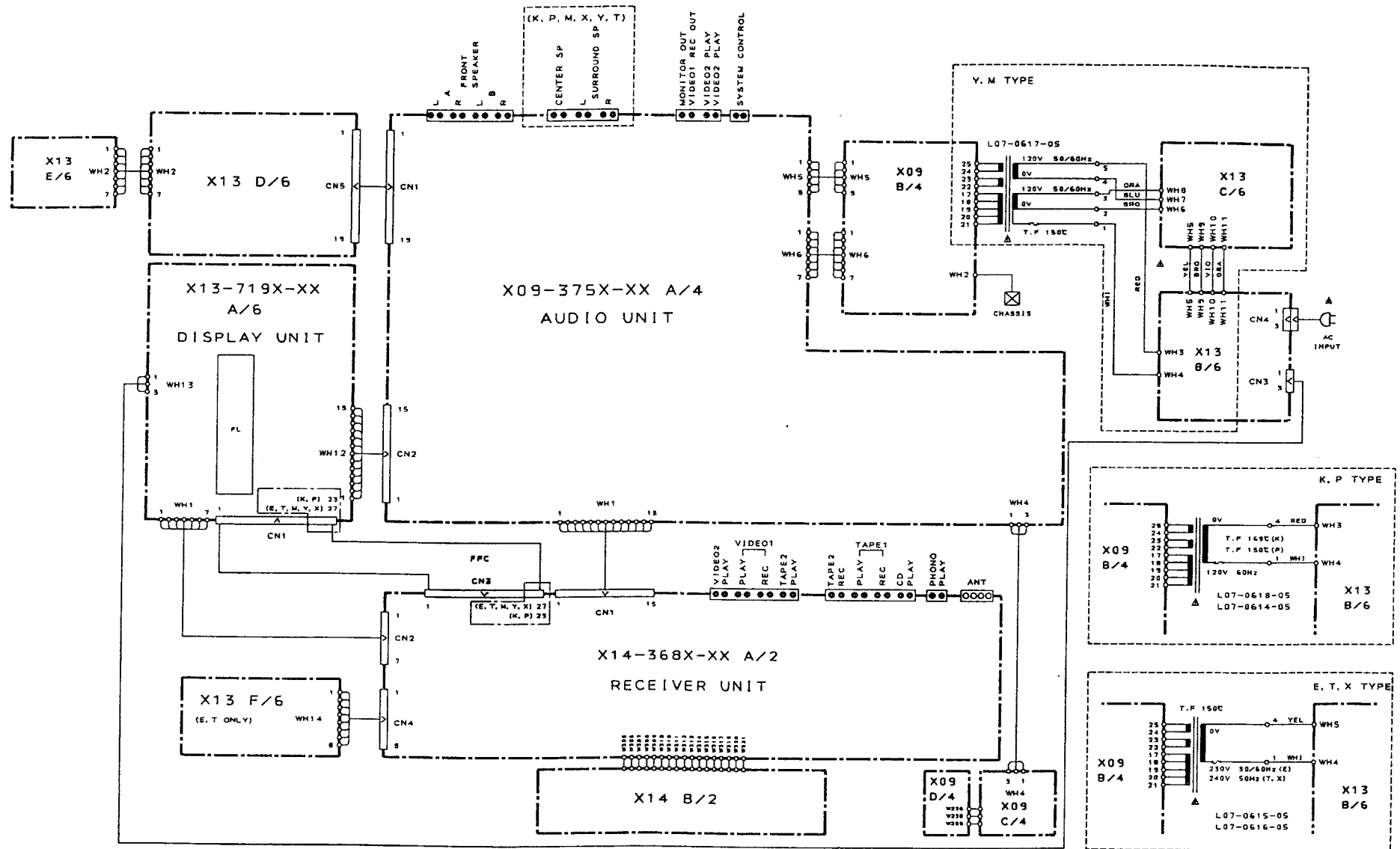

PC BOARD (Component side view)

AUDIO UNIT (X09-375X-XX)

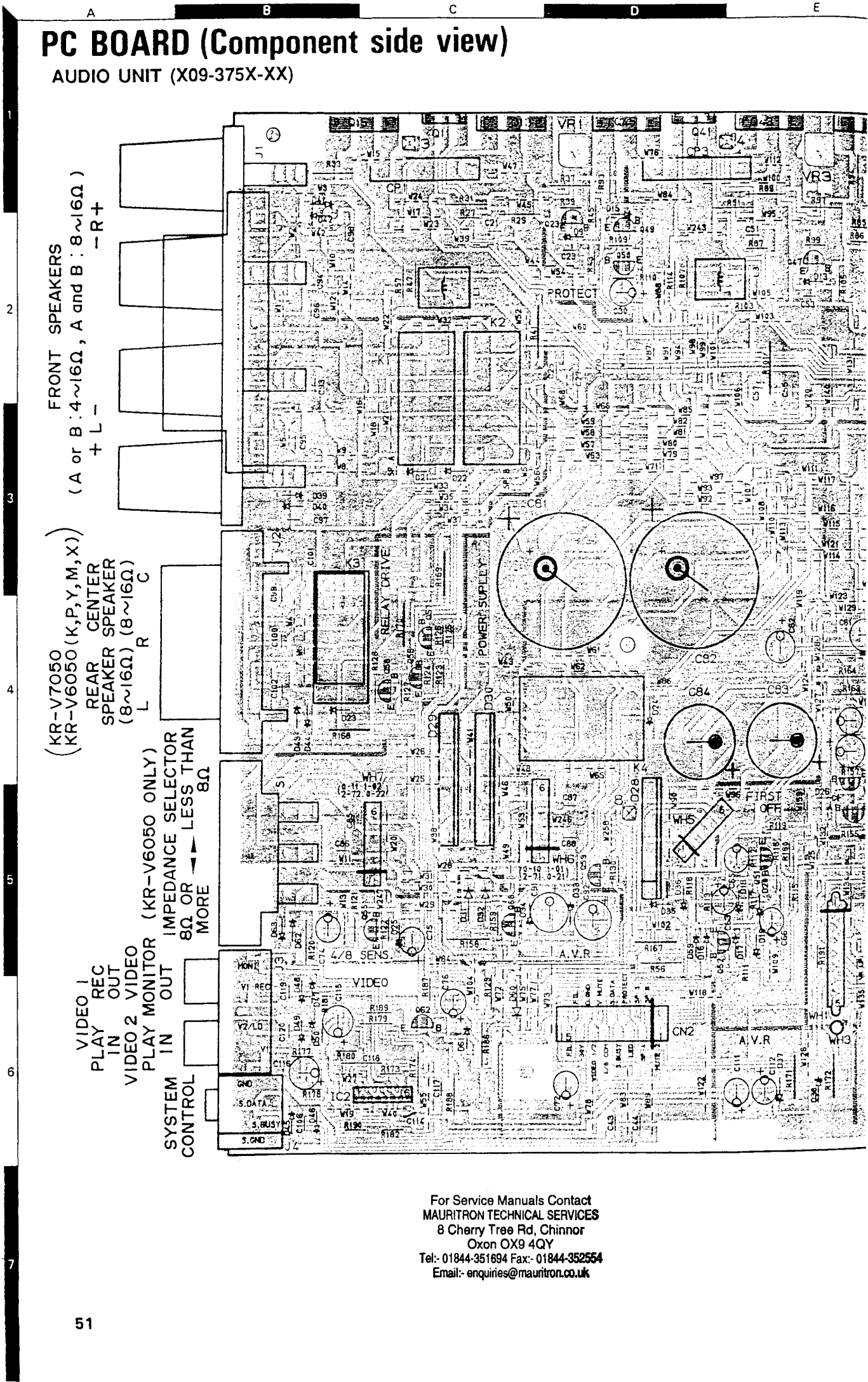

FRONT SPEAKERS
(A or B : 4~16Ω, A and B : 8~16Ω)
+ L -
- R +

(KR-V7050
KR-V6050 (K,P,Y,M,X))
REAR CENTER
SPEAKER
(8~16Ω) (8~16Ω)
L R C

VIDEO 1
PLAY REC
IN OUT
VIDEO 2 VIDEO
PLAY MONITOR
IN OUT
SYSTEM CONTROL
IMPEDANCE SELECTOR
8Ω OR MORE ←
← LESS THAN 8Ω

For Service Manuals Contact
MAURITRON TECHNICAL SERVICES
8 Cherry Tree Rd, Chinnor
Oxon OX9 4QY
Tel: 01844-351694 Fax: 01844-352554
Email: enquiries@mauritron.co.uk

Component side view)

X-XX)

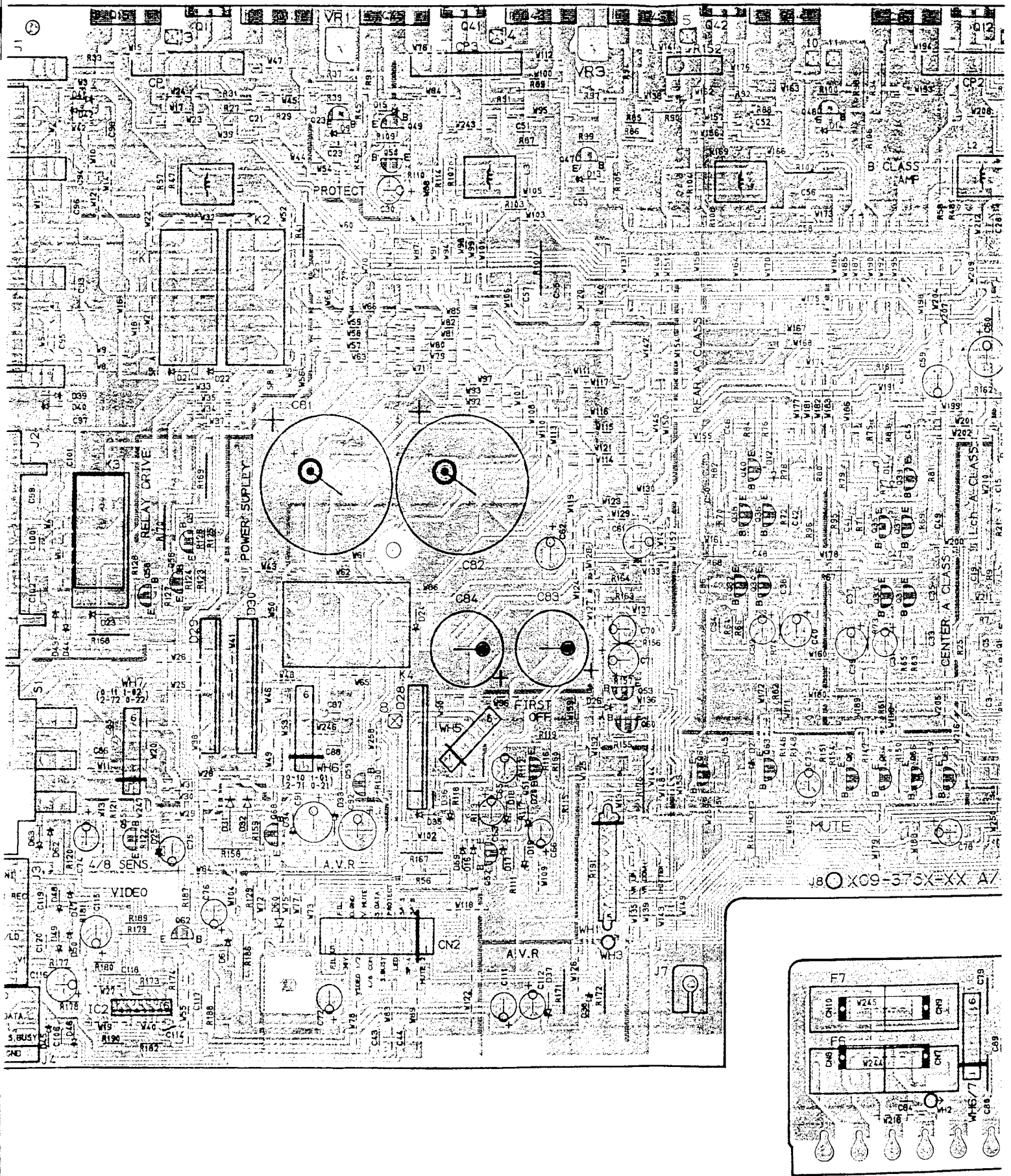

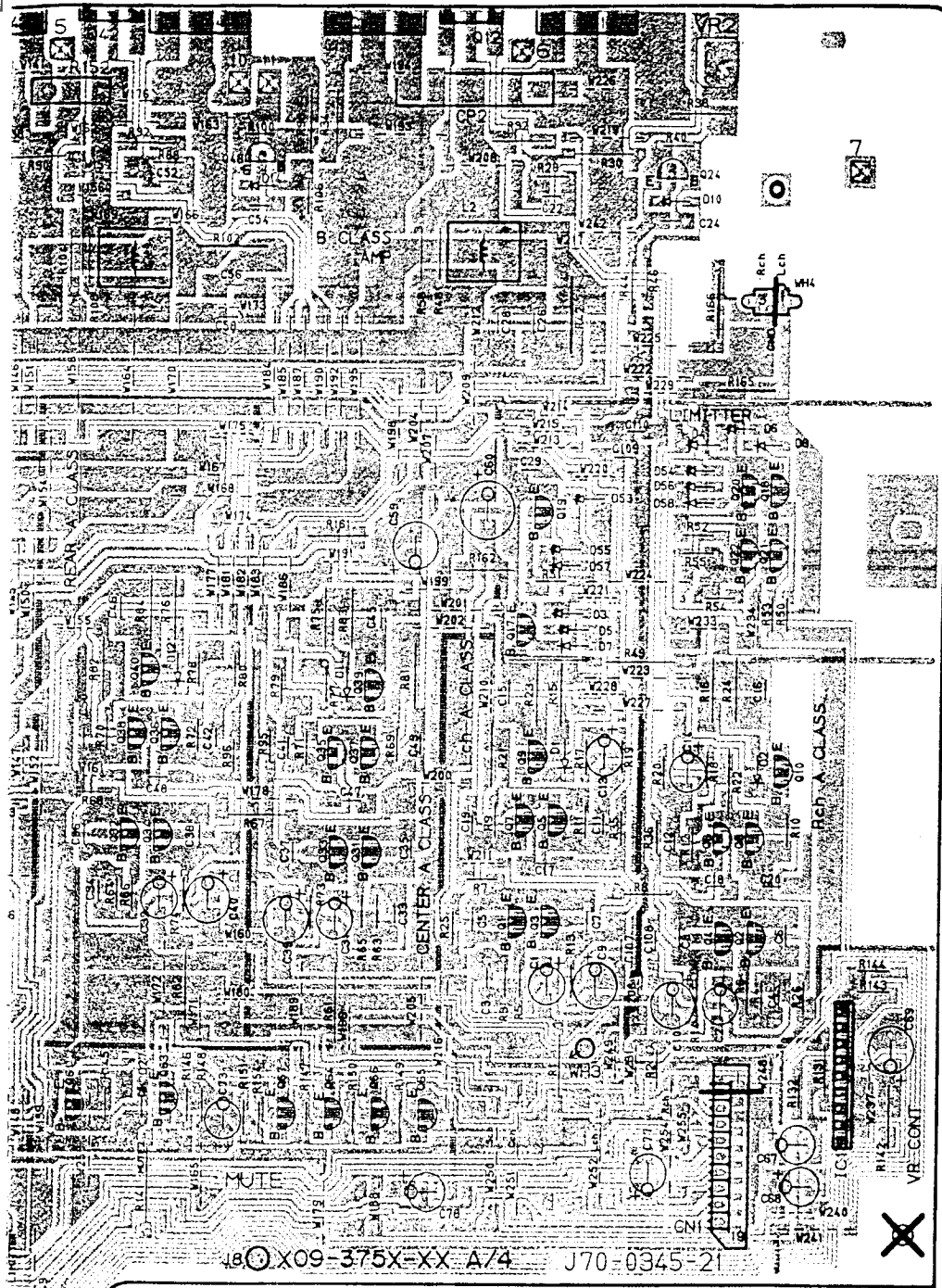

FRONT

For Service Manuals Contact
MAURITRON TECHNICAL SERVICES
 8 Cherry Tree Rd, Chinnor
 Oxon OX9 4QY
 Tel:- 01844-351694 Fax:- 01844-352554
 Email:- enquires@mauritron.co.uk

X09-375X-XX A74 J70-0345-21

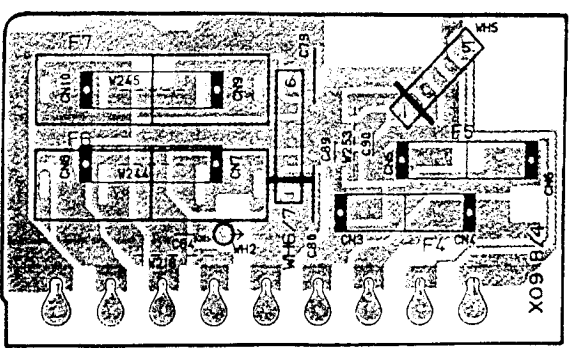

PHONES

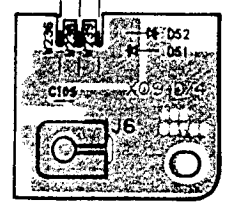
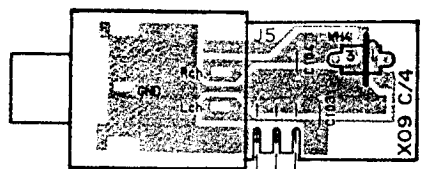

Refer to the schematic diagram for the values of resistors and capacitors.

PC BOARD (Component side view)

ACCESSORY UNIT
 (X13-720X-XX) : KR-V6050
 (X13-719X-XX) : KR-V7050

SWITCHED TOTAL 200W MAX.
 AC110-120V~/220-240V~
 50/60Hz

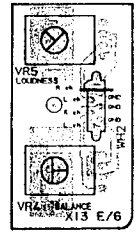
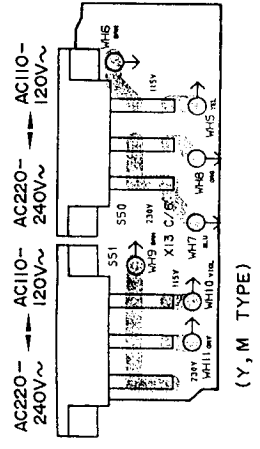
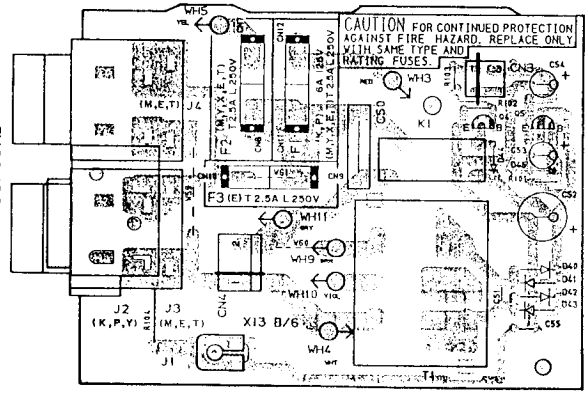

VOLUME CONTROL

(E, T TYPE)

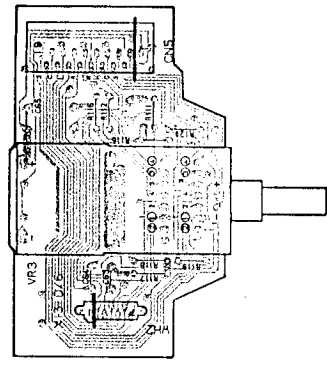
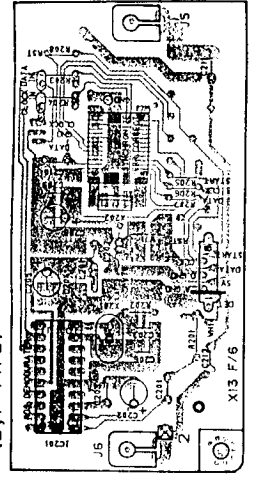

FRONT →

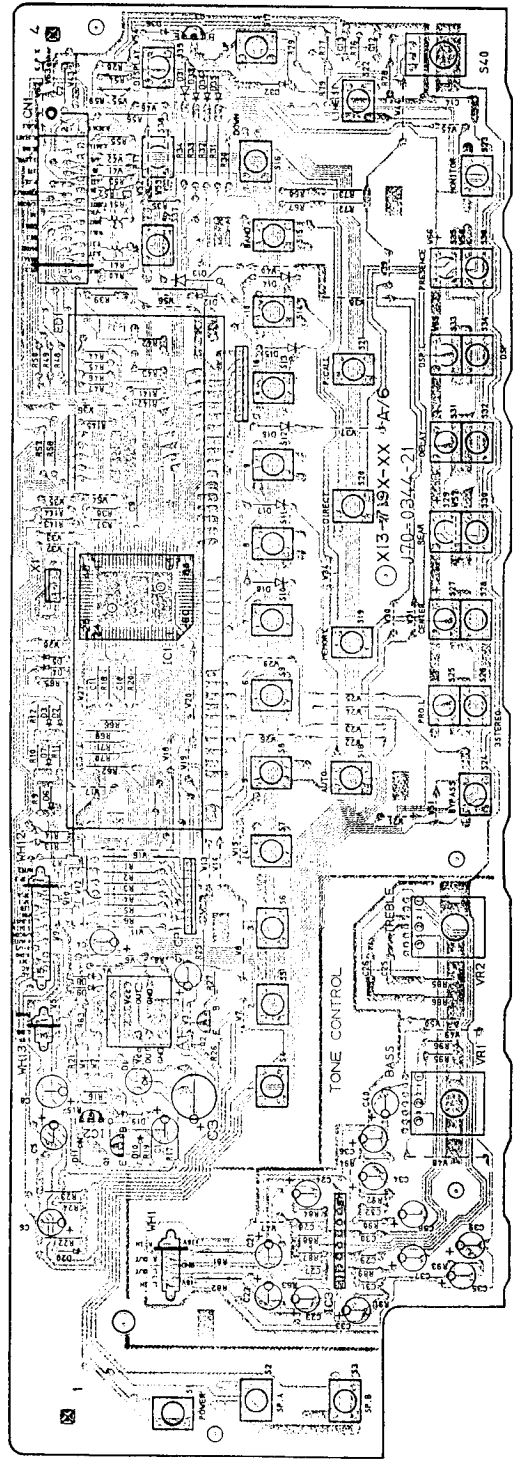

Refer to the schematic diagram for the values of resistors and capacitors.

U V W X Y
PC BOARD (Component side view)

RECEIVER UNIT (X14-368X-XX)

(KR-V7050 ONLY)

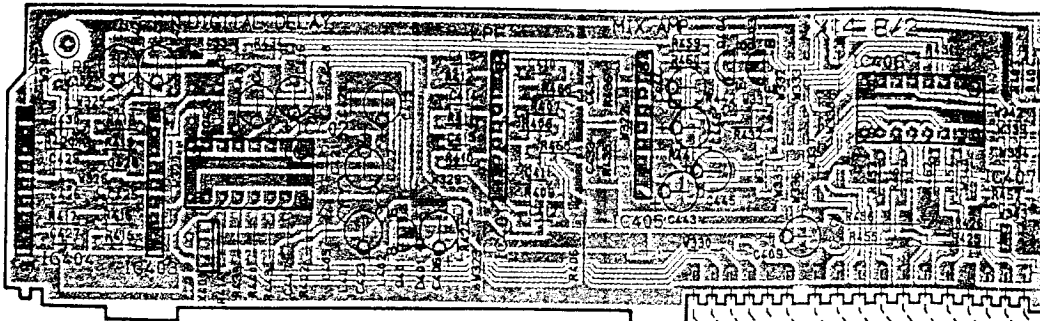

FRONT
←

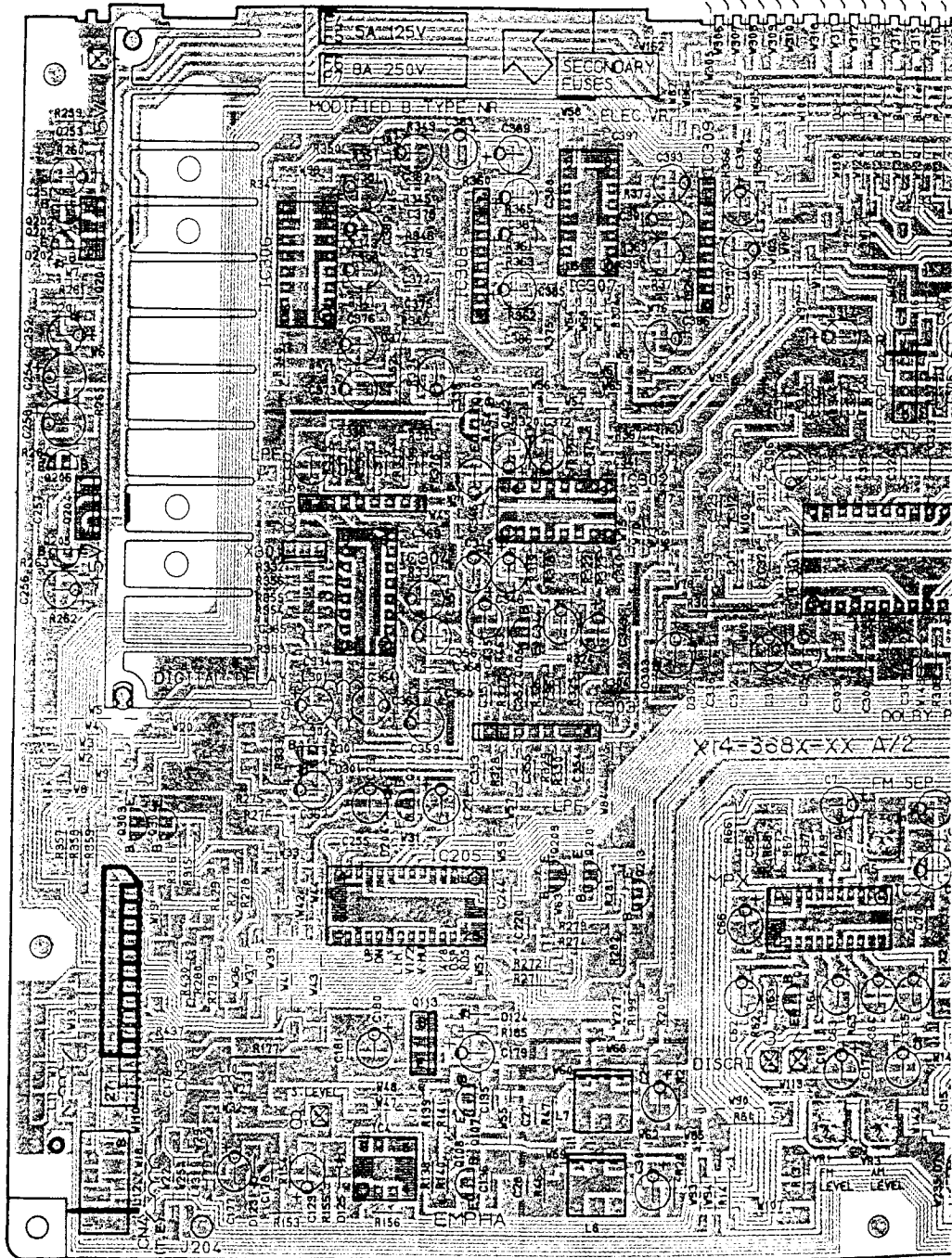

For Service Manuals Contact
MAURITRON TECHNICAL SERVICES
8 Cherry Tree Rd, Chinnor
Oxon OX9 4QY
Tel:- 01844-351694 Fax:- 01844-352554
Email:- enquires@mauritron.co.uk

Component side view)

I-368X-XX)

(KR-V7050 ONLY)

(KR-V7050 (+)
KR-V6050 (+)

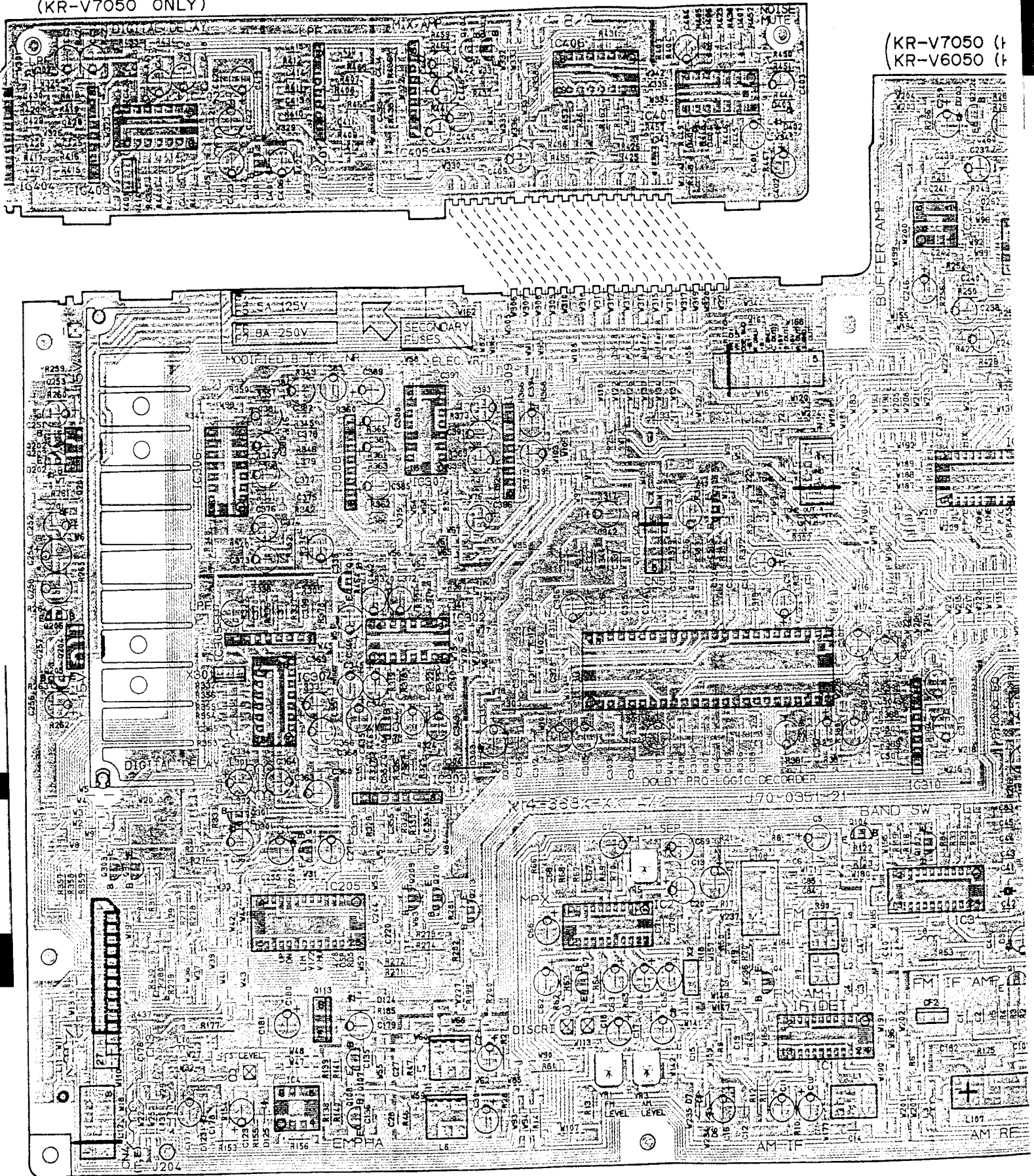

Refer to th

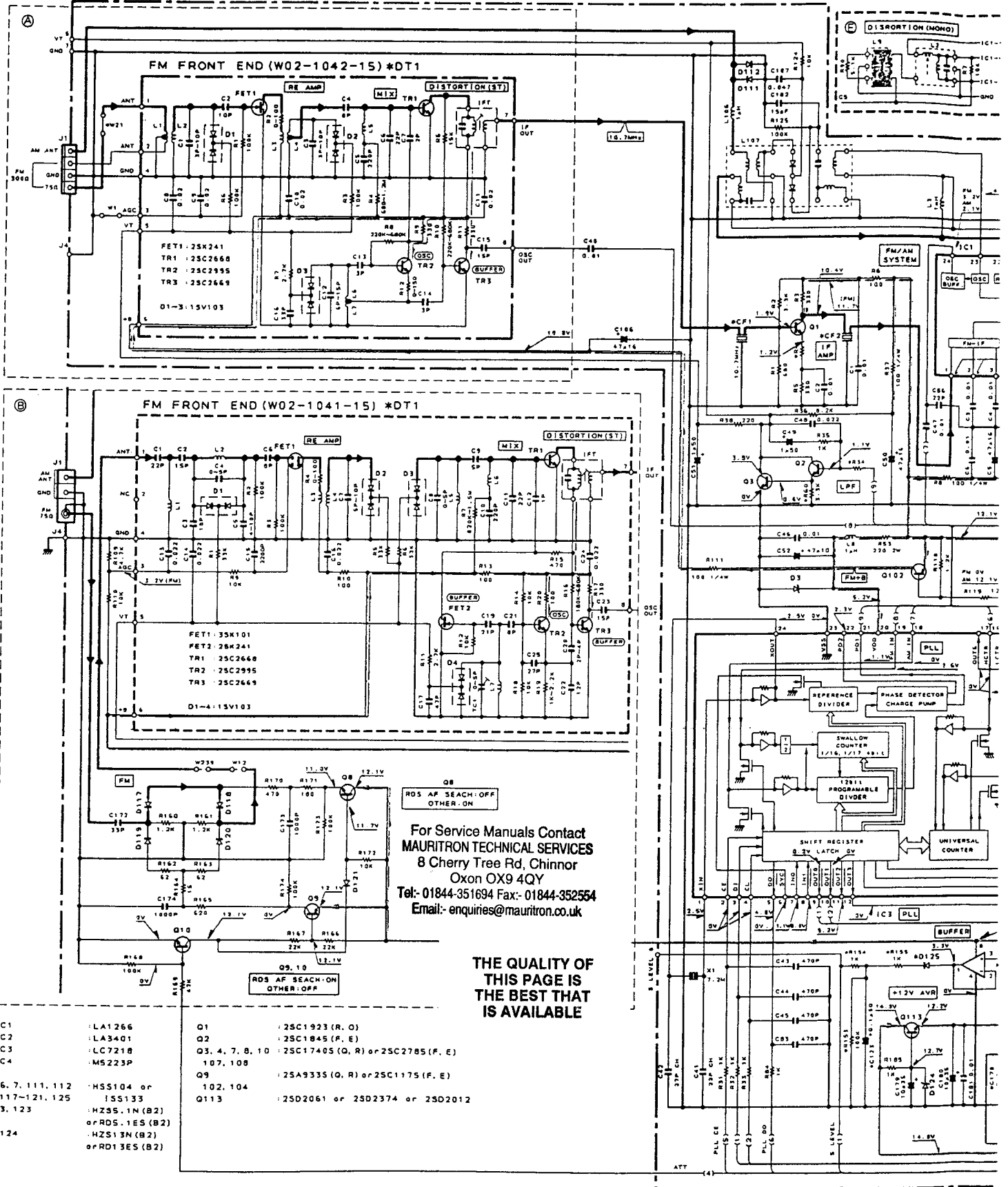

For Service Manuals Contact
MAURITRON TECHNICAL SERVICES
 8 Cherry Tree Rd, Chinnor
 Oxon OX9 4QY
 Tel: 01844-351694 Fax: 01844-352554
 Email: enquiries@mauritron.co.uk

**THE QUALITY OF
 THIS PAGE IS
 THE BEST THAT
 IS AVAILABLE**

- IC1 : LA1266
- IC2 : LA3401
- IC3 : LC7218
- IC4 : MS223P
- Q1 : 25C1923 (R, O)
- Q2 : 25C1845 (F, E)
- Q3, 4, 7, 8, 10 : 25C17405 (O, R) or 25C2785 (F, E)
- 107, 108
- Q9 : 25A9335 (O, R) or 25C1175 (F, E)
- 102, 104
- Q113 : 25D2061 or 25D2374 or 25D2012
- D6, 7, 111, 112 : HSS104 or
- 117-121, 125 : 1S5133
- O3, 123 : HZ35.1N (B2)
- or RDS.1ES (B2)
- D124 : HZS13N (B2)
- or RDI3ES (B2)

UNIT	ABB	DISTINATION	REF. NO	A	B	C	D	E	R4	R14	R17	R18	R15	R20	R21	R34	R43	R46	R47	R50	R60	R67	R68	R109	R110	R153	R154	R155	R156	R160	R162	R163	R164	R165	R166	R167	R168	R169	R170	R171	R172			
0-11	K, P	USA, CANADA		YES	NO	NO	YES	NO	56	4.7K	15K	12K	NO	NO	68	1/4W	10K	15K	33K	NO	3.3K	100K	NO	NO	NO	NO	NO	NO	NO	NO	NO	NO	NO	NO	NO	NO	NO	NO	NO	NO	NO	NO	NO	
0-22	Y, M	PX, OTHER AREAS		YES	NO	YES	YES	NO	56	4.7K	15K	12K	NO	NO	68	1/4W	10K	33K	33K	NO	3.3K	100K	NO	NO	NO	NO	NO	NO	NO	NO	NO	NO	NO	NO	NO	NO	NO	NO	NO	NO	NO	NO	NO	NO
0-72	X	AUSTRALIA		YES	NO	YES	NO	YES	NO	56	4.7K	15K	12K	NO	NO	68	1/4W	10K	33K	33K	NO	3.3K	100K	NO	NO	NO	NO	NO	NO	NO	NO	NO	NO	NO	NO	NO	NO	NO	NO	NO	NO	NO	NO	NO
2-70, 0-51	T, E	ENGLAND, EUROPE		NO	YES	NO	NO	YES	10	5.6K	12K	18K	3.3K	2.2K	47	1/4W	1K	33K	3.3K	47K	NO	220K	4.7K	10K	100K	1K	1K	10K	1.2K	62	15	620	22K	100K	47K	470	180	10K						

DC voltages are as measured with a high impedance voltmeter. Values may vary slightly due to variations between individual instruments or/and units.

Les tensions c.c. doivent être mesurées avec un voltmètre à haute impédance. Les valeurs peuvent différer légèrement du fait des variations inhérentes aux appareils et aux instruments de mesure individuels.

Die angegebenen Gleichspannungen sind mit einem hochimpedanten Spannungsmessgerät gemessen worden. Die Meßwerte können aufgrund von Unterschieden zwischen den Instrumenten oder Geräten...

IC201, 204 NJM45800-D IC205 NJU7312L IC303, 308-310 NJM4565L IC306 LA2730 Q201, 204
 IC202 NJU7313L IC301 S5M2126P IC304 YM1208 IC307 TC9213P Q202, 203, 209
 IC203 NJU7311L IC302 NES71M IC305 M5230AL Q203, 204, 205, 209
 210, 213, 303
 304, 306

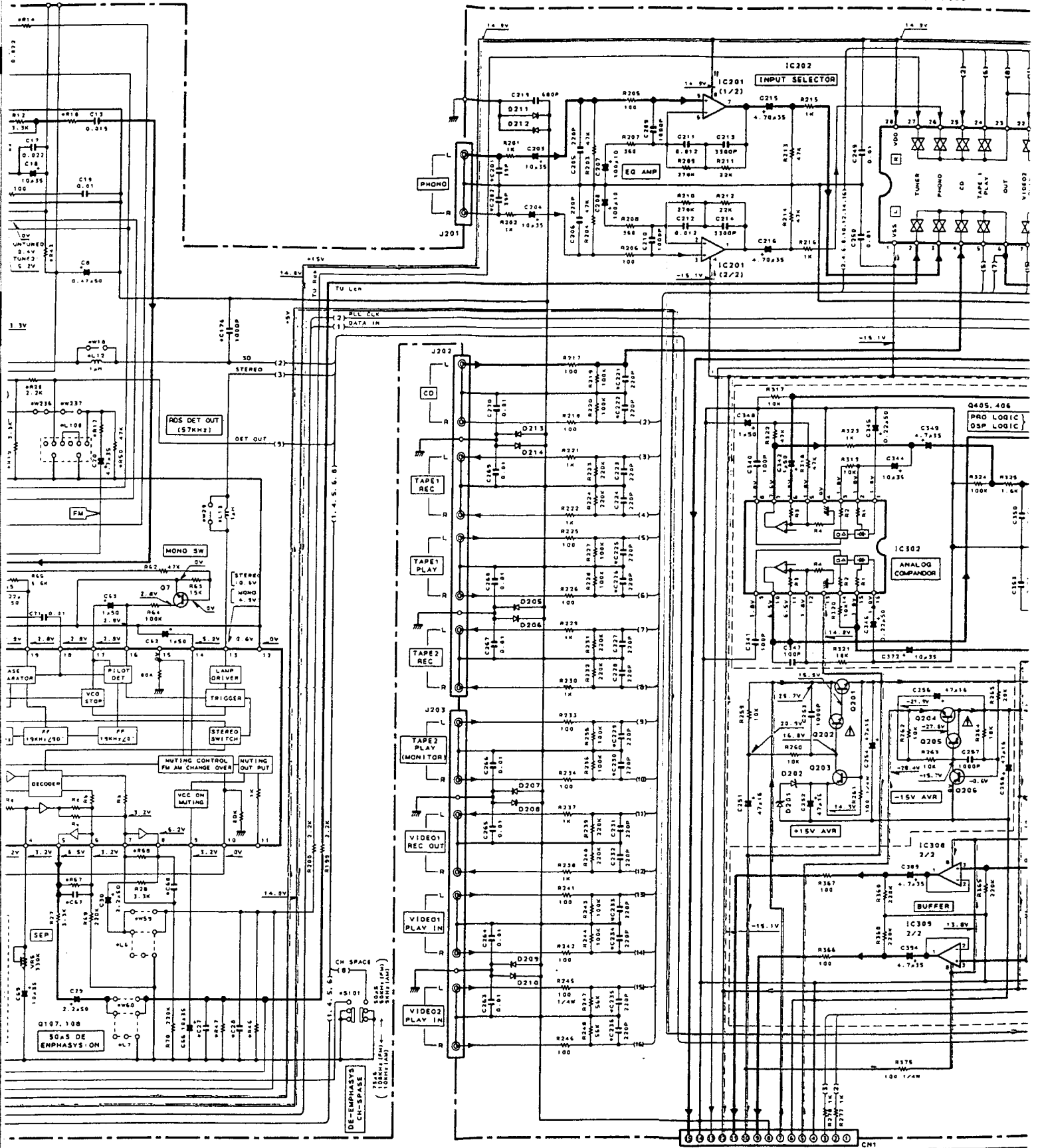

7	C178	L2	L6	L5	L10	L12	L13	L10B	Q4	Q107, 108	Q6	D117-121, 125	D123	CF1, 2	IC4	3101	DT1	
1	NO	L30-0439	NO	NO	NO	YES	YES	NO	NO	NO	NO	NO	NO	NO	L72-0531	NO	NO	W02-1042
2	NO	L30-0494	NO	NO	NO	YES	YES	NO	NO	YES	NO	NO	NO	NO	L72-0531	NO	YES	W02-1042
3	NO	L30-0494	NO	NO	NO	YES	YES	NO	NO	NO	NO	NO	NO	NO	L72-0531	NO	NO	W02-1042
10	0.01	L30-0484	YES	L30	0485	YES	W18	W29	YES	YES	NO	YES	YES	YES	L77-0534	YES	NO	W02-1041

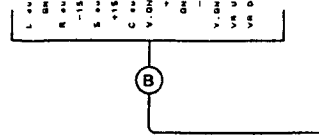

UNIT	ABB
0-11	K, P
0-22	V, M, PX
0-72	X
2-72	E
0-51	T

For continued safety, replace safety critical components with manufacturer's recommended parts (refer to Δ indicates safety critical components. To reduce the shock, leakage-current or resistance measurements ed out (exposed parts are acceptably insulated from rcuit) before the appliance is returned to the custom-

K M N O

IC306 LA2730 Q201, 204 2SD2061 or 2SD2012 or 2SD2374 Q205, 206, 212 2SA9335 (Q, R) or 2SA1048 (Y, GR) or 201, 302, 303 RD6, 2
 IC307 TC9213P Q202, 203, 209 2SC17405 (O, R) or 2SC2458 (Y, GR) or 2SA1175 (F, E) or 2SA1309A (Q, R) D202 RD8, 2
 210, 213, 303 2SC2785 (F, E) or 2SC3311A (O, R) Q207, 208, 2SC2078 (B) D203 RD3, 9
 304, 306 Q211, 301 2SC2003 (L, K)

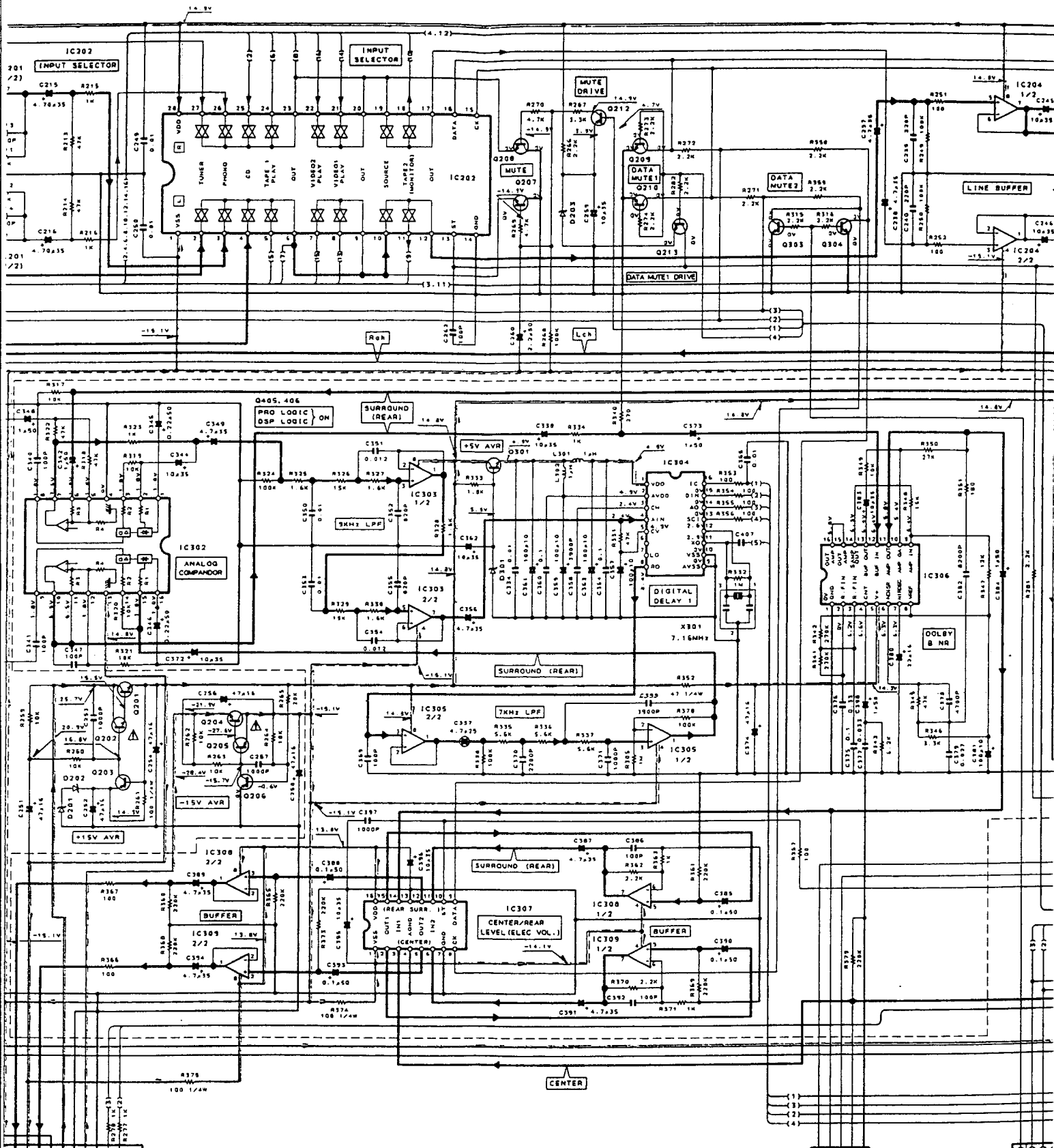

UNIT	ABB	REF. NO.	A	C201, 202, 221, 222, 225, 226, 229, 230, 233-236, 241, 242	CNS, Q303, 304, R315, 316, 350, 355, 375	CN3	L11	CN4
0-11	K, P	USA, CANADA	YES	NO	YES	23P	YES	NO
0-22	Y, M	PX, OTHER AREAS	YES	NO	YES	27P	YES	NO
0-72	X	AUSTRALIA	YES	NO	YES	27P	YES	NO
2-72	E	EUROPE	NO	YES	NO	27P	NO	YES
0-51	T	ENGLAND	YES	NO	YES	27P	NO	YES

THE QUALITY OF THIS PAGE IS THE BEST THAT IS AVAILABLE

1er
R) D201, 302, 303 RD6, 2E5 (B2) or HZ56, 2N (B2)
D202 RD8, 2E5 (B2) or HZ58, 2N (B2)
D203 RD3, 9E5 (B2) or HZ53, 9N (B2)

D204, 301, RD5, 6E5 (B2) or HZ55, 6N (B2)
D205-214 15S133 or H55104

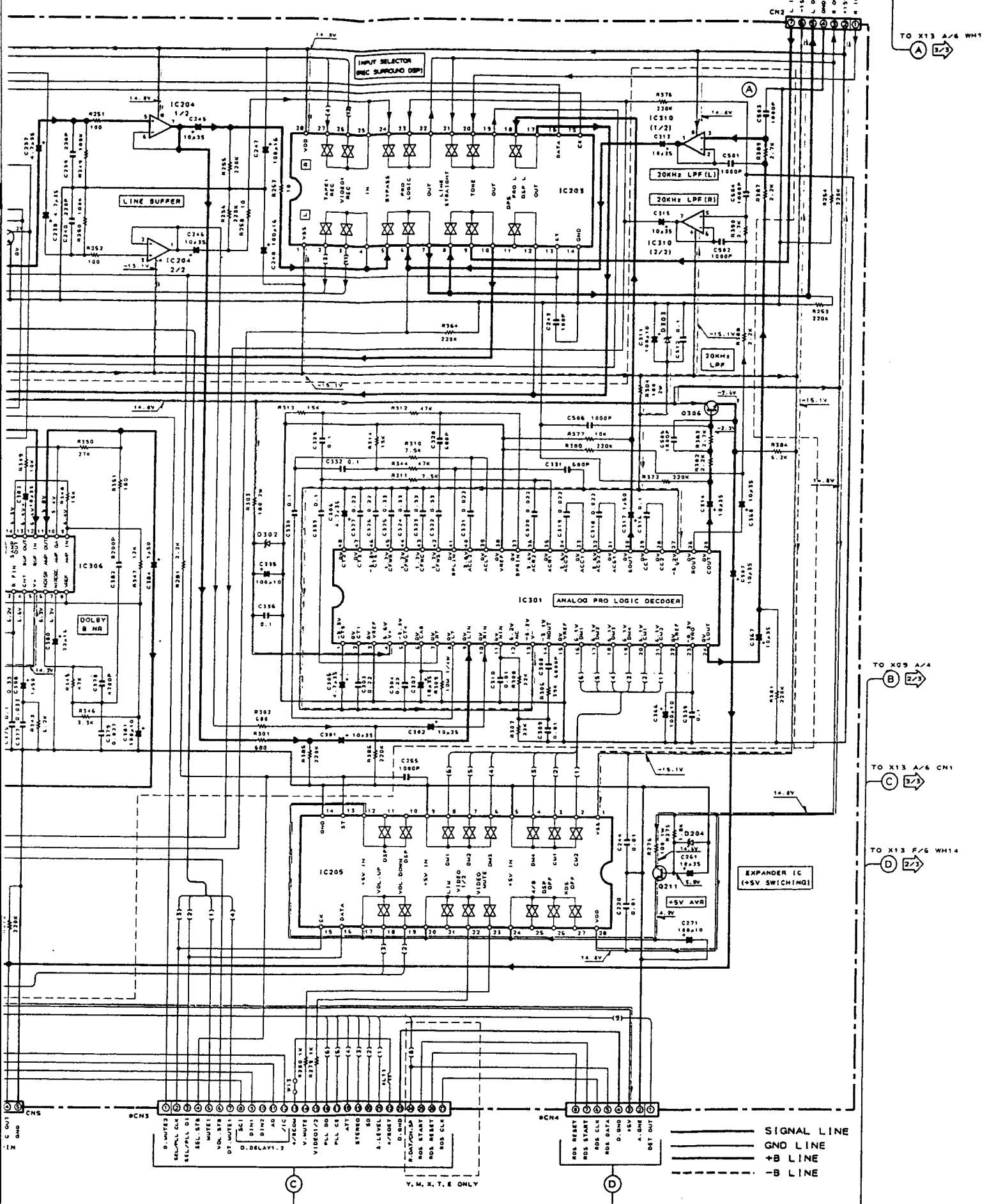

- 18) D-MUTES
- 19) SEL/PULL DI
- 20) SEL. SER
- 21) MUTE1
- 22) VOL. SER
- 23) DT. MUTE1
- 24) D. DELAY1
- 25) A/REC
- 26) V-MUTE
- 27) VIDEO/2
- 28) ALL OFF
- 29) PULL OFF
- 30) STEREO
- 31) S. LEVEL
- 32) /SERVO
- 33) D-DATCH/SP
- 34) RDS START
- 35) RDS RESEY
- 36) RDS CLK

- 37) RDS RESEY
- 38) RDS START
- 39) RDS CLK
- 40) RDS DATA
- 41) D. SHD
- 42) A. SHD
- 43) DET. OUT

SIGNAL LINE
GND LINE
+B LINE
-B LINE

(X09-375X-XX) (A/4)

For Service Manuals Contact
MAURITRON TECHNICAL SERVICES
 8 Cherry Tree Rd, Chinnor
 Oxon OX9 4QY
 Tel: 01844-351694 Fax: 01844-352554
 Email: enquiries@mauritron.co.uk

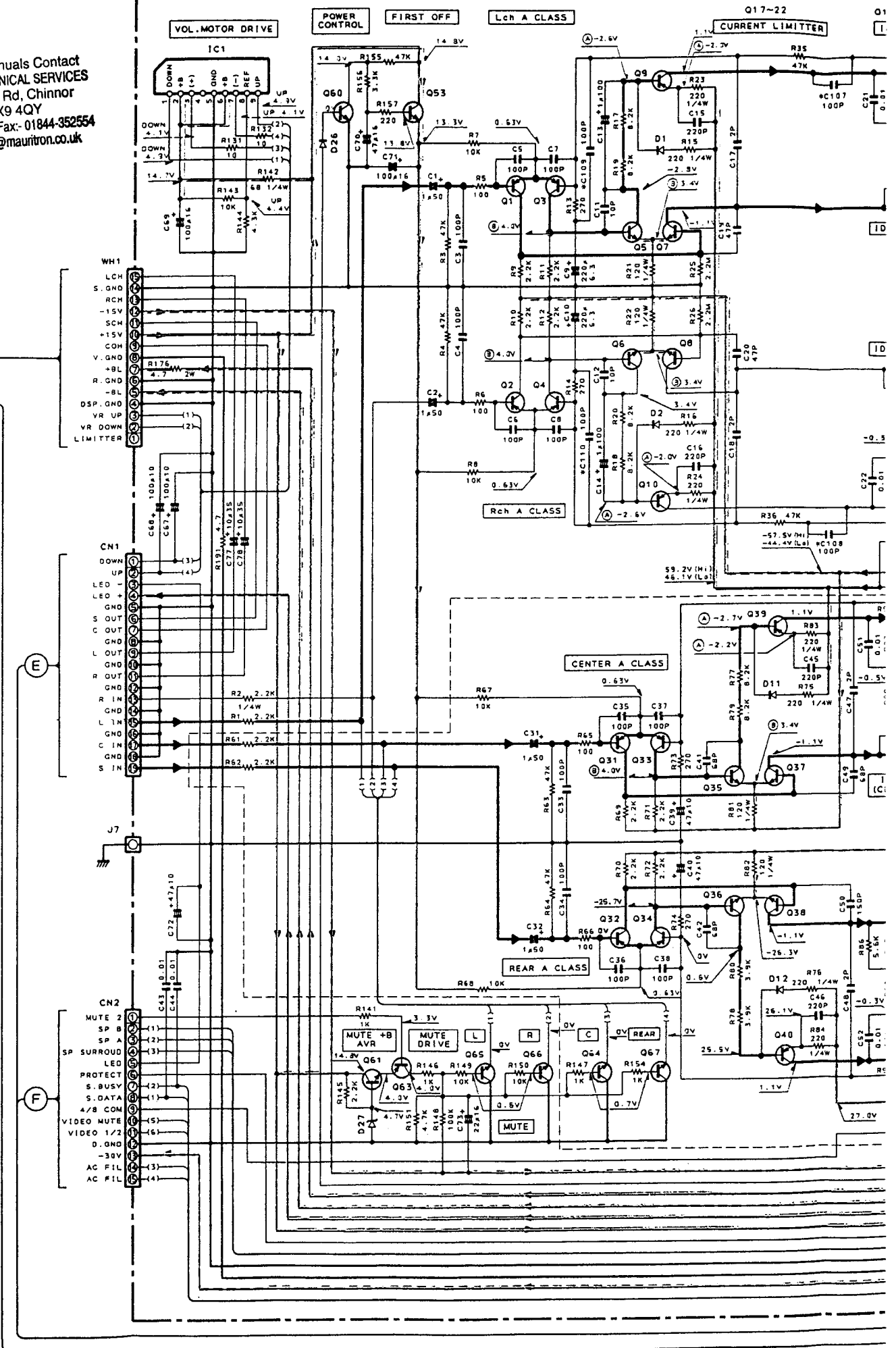

2

3

4

5

6

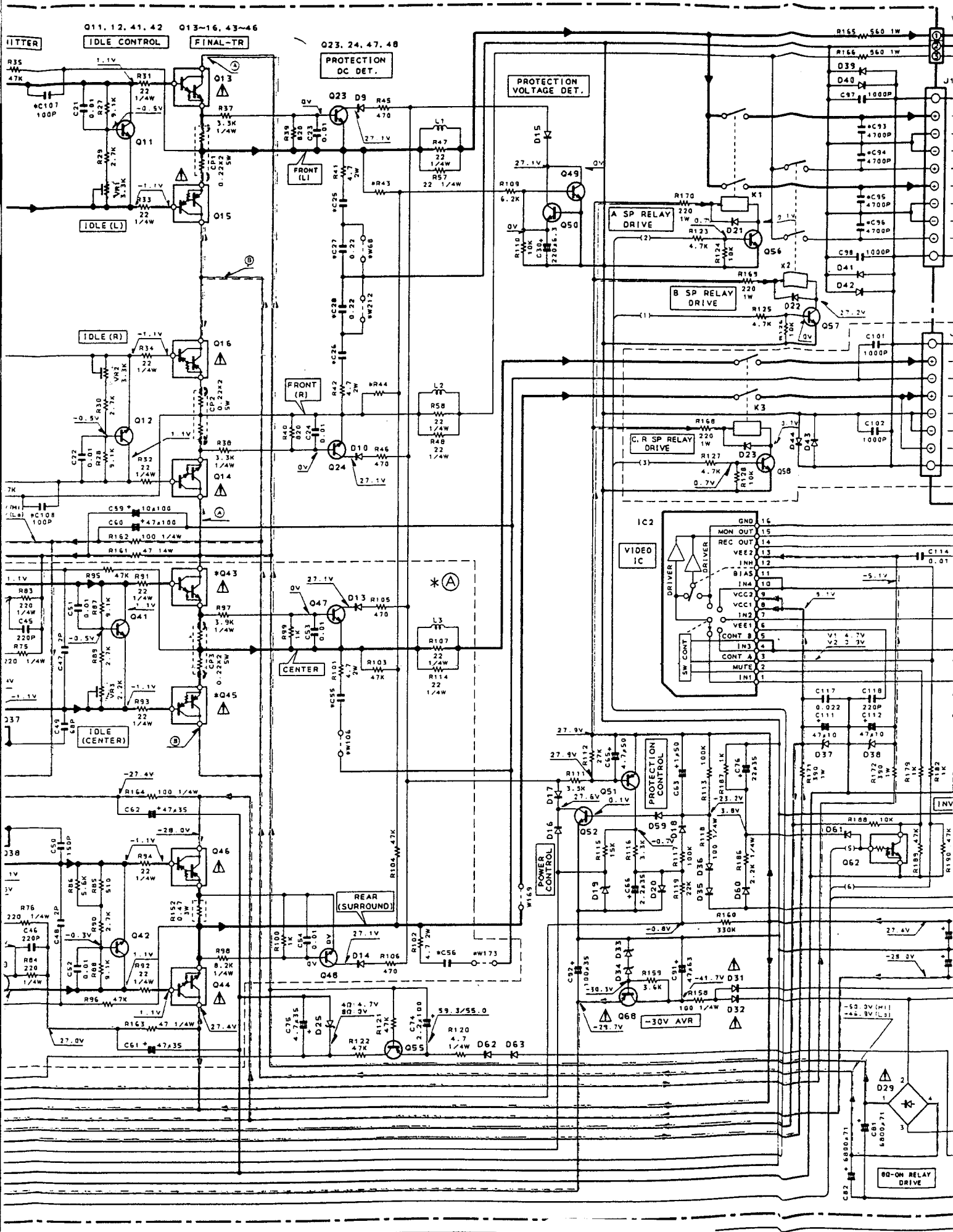

THE QUALITY OF
THIS PAGE IS
THE BEST THAT
IS AVAILABLE

(X09-) (C/4)

X13 F/6

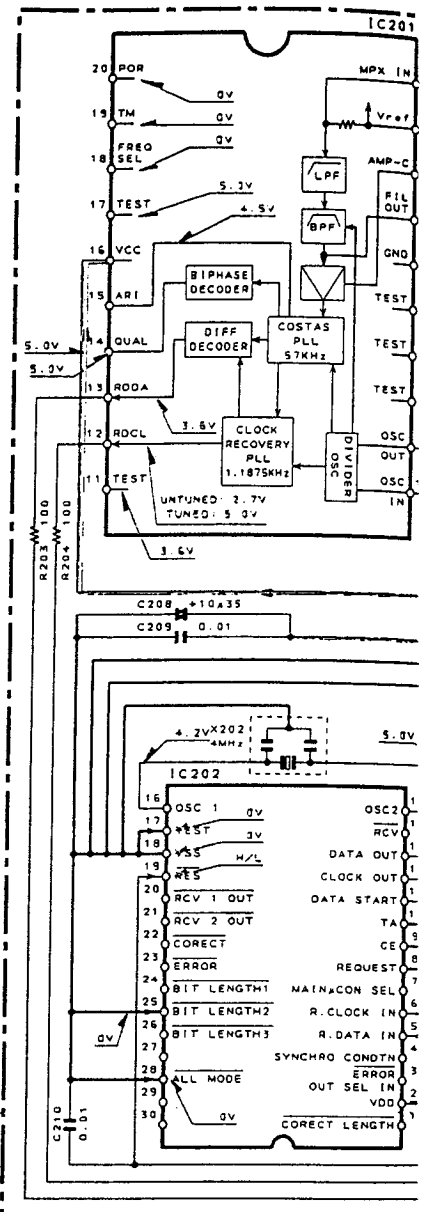
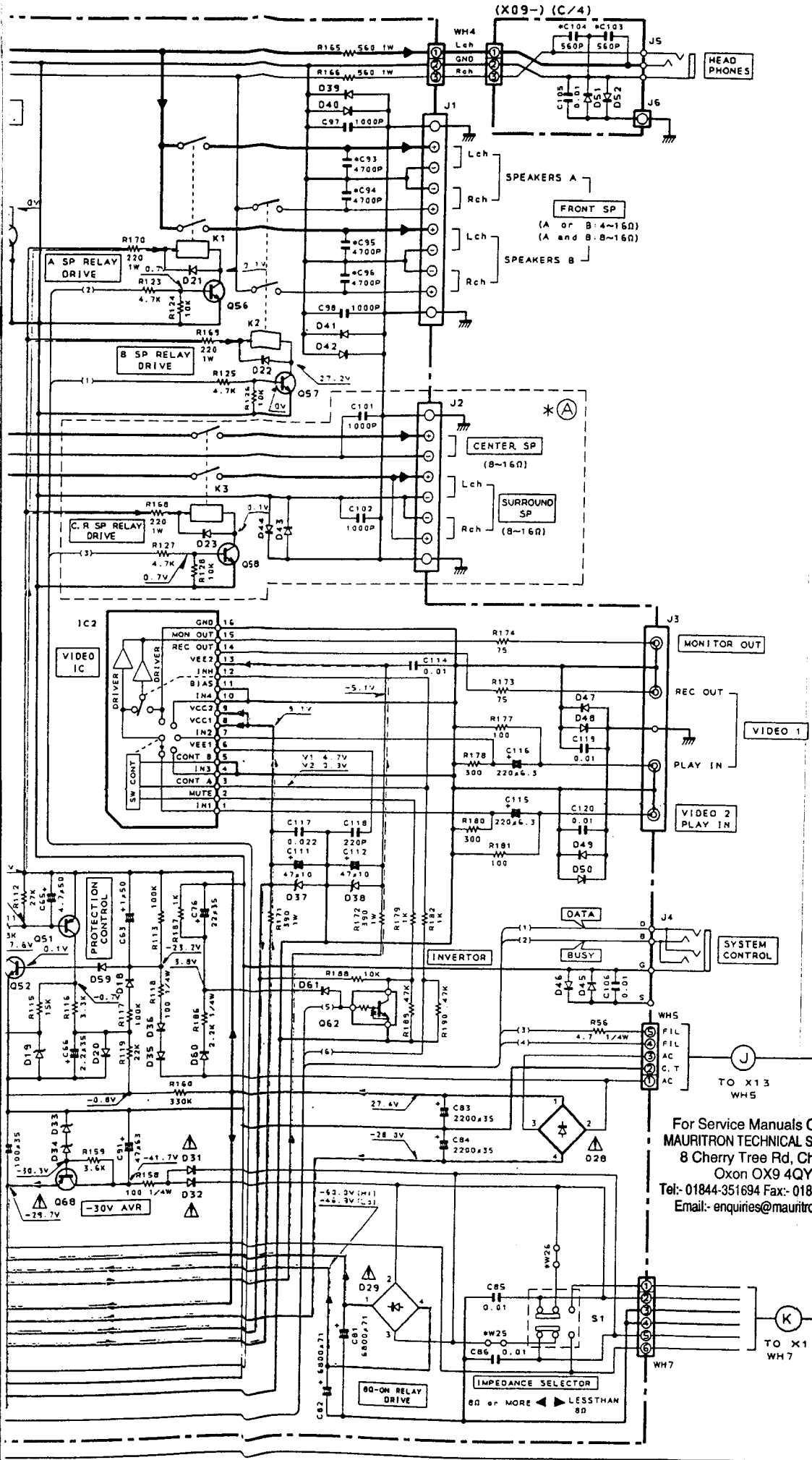

X09-375X-XX A/4

IC1	:TA84095
IC2	:CXA155BL
Q1-4, 31-34	
40, 51	:2SA992 (F, E)
Q5-8, 35, 37	:2SC2631 (R, S)
Q9, 10, 39	:2SA1123 (R, S)
Q11, 12, 41, 42	:2SC4137F19 (V)
Q13, 14	:2SD2449LB or
Q15, 16	:2SB1594LB or
Q23, 24, 36, 38	
47-50, 52	:2SC1845 (F, E)
Q63	:2SA9335 (Q, R)
Q53, 56-58, 60, 61	:2SC1740S (Q, R)
*Q43	
Q44	:2SD2340BT
*Q45	
Q46	:2SB1531BT
Q62	:UN4212 or DTC
Q64-67	:2SC2878 (B)
D1, 2, 9-18, 20-23,	
26, 35, 36, 59-63	:HSS104A or 1S
D19, 25, 37, 38	:HZS5.1N (B2) c
D27	:HZS4.7N (B2) c
D28	:D3SBA20F03 c
D29	:D5SBA20F03 c
D31, 32	:S5688B or 1S
D33	:HZS15N (B2) or
D34	:HZS16N (B2) a
D39-52	:HSS104 or 1S

For Service Manuals Contact
MAURITRON TECHNICAL SERVICES
 8 Cherry Tree Rd, Chinnor
 Oxon OX9 4QY
 Tel: 01844-351694 Fax: 01844-352554
 Email: enquiries@mauritron.co.uk

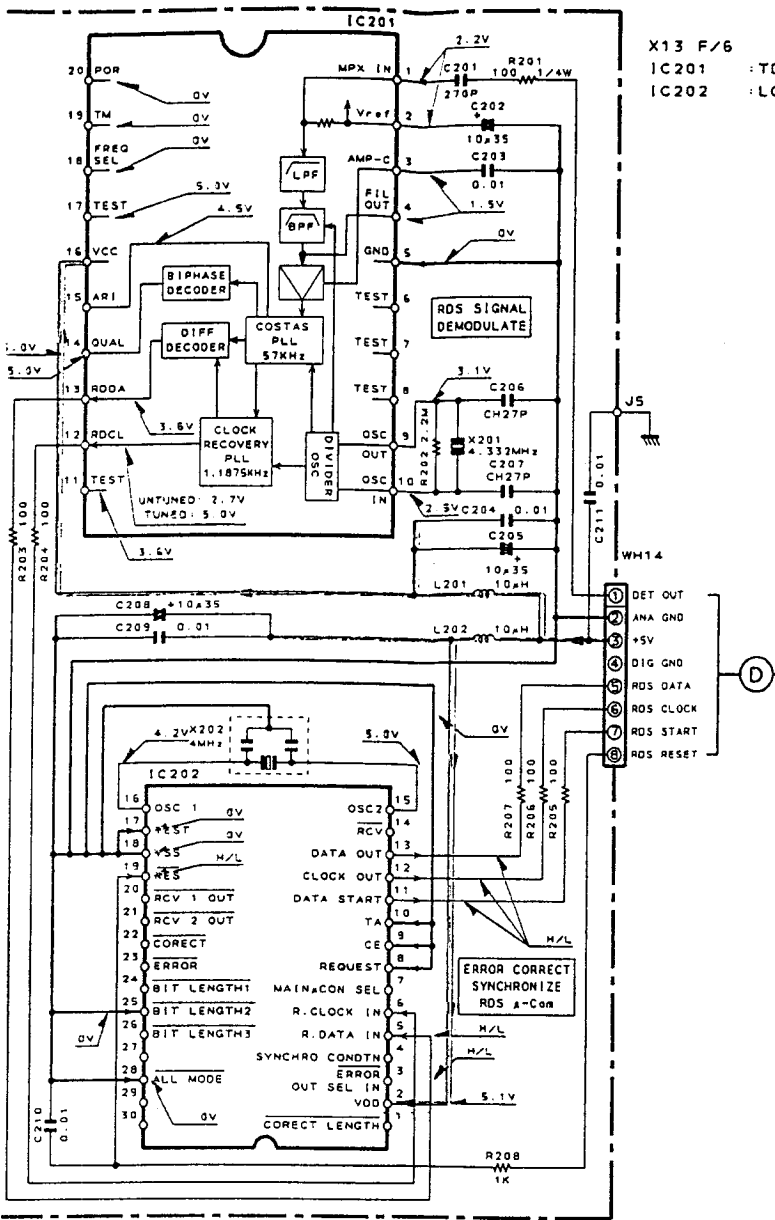

X13 F/6
 IC201 : TDA7330A
 IC202 : LC6543H-4600

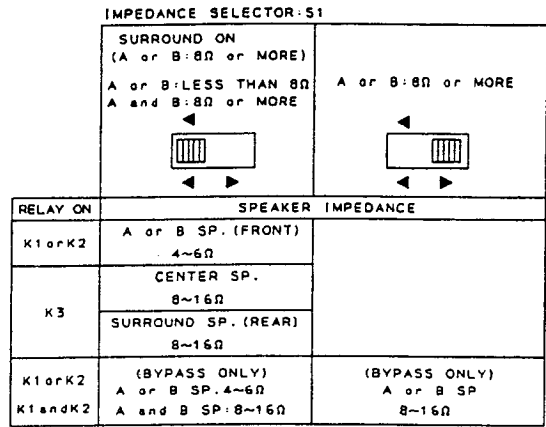

IMPEDANCE SELECTOR S1

SURROUND ON		SURROUND OFF	
A or B: LESS THAN 8Ω (4Ω)		A or B: 8Ω or MORE (8Ω)	
(A)	47.0V	47.0V	
(B)	-47.0V	-60.1V	

DESTINATION Ref.No.	K 0-11	P 1-02	E 2-72	Y, M, X, T 0-22
(A)	YES	YES	NO	YES
R43, 44	47K	47K	100K	47K
C25, 26, 55, 56	0.1μ	0.1μ	0.22μ	0.1μ
C27, 28	NO	NO	YES	NO
C93, 94, 95, 96	NO	NO	YES	NO
103, 104, 107-110	NO	NO	YES	NO
W6B, 212	YES	YES	NO	YES
W106, 173	YES	YES	NO	YES

DESTINATION Ref.No.	K 0-10	P 1-01	T, E 2-71	Y, M, X 0-21
*Q43	YES	NO	NO	NO
2SD2255BT	YES	NO	NO	NO
2SD2255BY*1	NO	YES	YES	YES
2SD2384LB	NO	YES	YES	YES
*Q45	YES	NO	NO	NO
2SB1493BT	YES	NO	NO	NO
2SB1493BT*1	NO	YES	YES	YES
2SB1555LB	NO	YES	YES	YES

IC2 TRUTH TABLE

CONTROL SIGNAL				OUT PUT	
CONTA 3P IN	CONTRB 5P IN	MUTE 2P IN	1NH 12P IN	REC OUT 14P IN	MONI OUT 15P IN
L	L	L	L	INPUT1 (1P IN) FROM VIDEO 2PLAY	
H	L	H	H	INPUT2 (7P IN) FROM VIDEO 1PLAY	
*	*	H	L	GND	

0&L \$1.5V H\$23.5V * : DONT CARE

- X09-375X-XX A/4
- IC1 : TA8409S
 IC2 : CXA155BL
- Q1~4, 31~34 : 40, 51 : 2SA992 (F, E)
 Q5~8, 35, 37 : 2SC2631 (R, S)
 Q9, 10, 39 : 2SA1123 (R, S)
 Q11, 12, 41, 42 : 2SC4137F19 (V, W)
 Q13, 14 : 2SD2449LB or 2SD2222BT
 Q15, 16 : 2SB1594LB or 2SB1470BT
 Q23, 24, 36, 38 : 47~50, 52 : 2SC1845 (F, E)
 Q63 : 2SA933S (Q, R) or 2SA1175 (F, E)
 Q53, 56~58, 60, 61 : 2SC1740S (Q, R) or 2SC2785 (F, E)
 *Q43 : Q44 : 2SD2340BT
 *Q45 : Q46 : 2SB1531BT
 Q62 : UN4212 or DTC124ES
 Q64~67 : 2SC287B (B)
- O1, 2, 9~18, 20~23, 26, 35, 36, 59~63 : HSS104A or 1SS131
 O19, 25, 37, 38 : HZS5.1N (B2) or RDS.1ES (B2)
 O27 : HZS4.7N (B2) or RD4.7ES (B2)
 O28 : D3SBA20F03 or RBV-402LFA
 O29 : D5SBA20F03 or RBV-602LFA
 O31, 32 : S5688B or 1SR139-100
 O33 : HZS15N (B2) or R015ES (B2)
 O34 : HZS16N (B2) or R016ES (B2)
 O39~52 : HSS104 or 1SS133

THE QUALITY OF THIS PAGE IS THE BEST THAT IS AVAILABLE

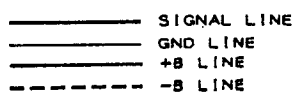
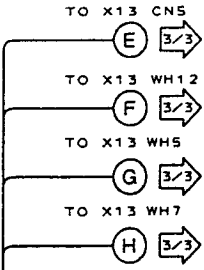

DC voltages are as meter. Values may vary slightly from individual instruments or parts.

Les tensions c.c. doivent être mesurées à haute impédance. Les variations inhérentes à la mesure individuelle.

Die angegebenen Gleichspannungen sind Messwerte auf seinen Instrumenten oder

CAUTION: For continuity tests only with manufacturer's instructions. ⚠ Indicates risk of electric shock, test should be carried out (except the supply circuit) before.

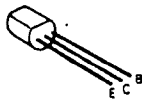

2SA1123
2SA1534A
2SA992
2SC1845
2SC1923
2SC2003
2SC2631
2SC2878
2SC3940A

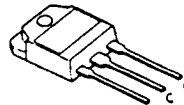

2SB1493BT
2SB1493BT*1
2SB1531BT
2SD2255BT
2SD2255BT*1
2SD2340BT



2SA1175
2SC2785



2SD2061

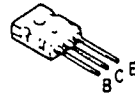

2SB1470BT
2SD2222BT

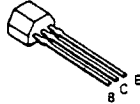

DTC124ES
2SA1048
2SA933S
2SC1740S
2SC2458



2SD2012
2SD2374

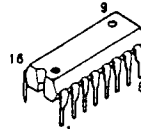

NE571N

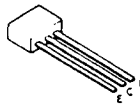

UN4212
2SA1309A
2SC3311A

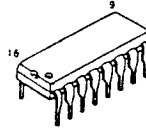

LA2730

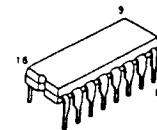

TC9213P
TC9215P

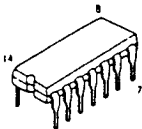

UPC4574C

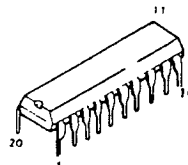

TDA7330A

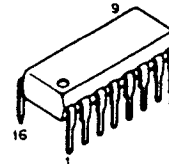

YM7128B

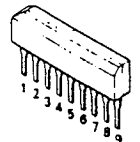

TA8409S

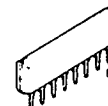

M5238AL

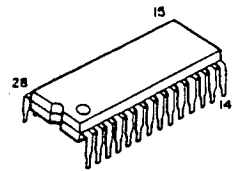

NJU7311L
NJU7312L
NJU7313L

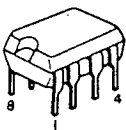

M5223P
NJM4580D-D

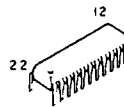

LA3401

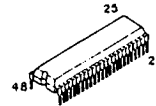

SSM2126P

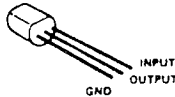

PST529C

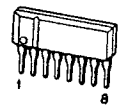

NJM4565L

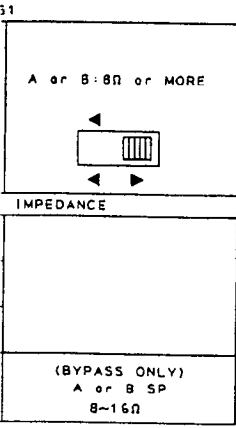

OUND OFF	8Ω or MORE (8Ω)
47.0V	
-60.1V	

E	Y. M. X. T
2-72	0-22
NO	YES
100K	47K
1.22μ	0.1μ
YES	NO
YES	NO
NO	YES
NO	YES

T. E	Y. M. X
2-71	0-21
NO	NO
YES	YES
NO	NO
YES	YES

JT
(ON) OUT
15P IN
(IN) FROM
PLAY
2 (7P IN)
IDEO IPLAY
ID
CARE

DC voltages are as measured with a high impedance voltmeter. Values may vary slightly due to variations between individual instruments or/and units.

Les tensions c.c. doivent être mesurées avec un voltmètre à haute impédance. Les valeurs peuvent différer légèrement du fait des variations inhérentes aux appareils et aux instruments de mesure individuels.

Die angegebenen Gleichspannungswerte wurden mit einem hochohmigen Spannungsmesser gemessen. Dabei schwanken die Meßwerte aufgrund von Unterschieden zwischen einzelnen Instrumenten oder Geräten u. U. geringfügig.

CAUTION: For continued safety, replace safety critical components only with manufacturer's recommended parts (refer to parts list). indicates safety critical components. To reduce the risk of electric shock, leakage-current or resistance measurements shall be carried out (exposed parts are acceptably insulated from the supply circuit) before the appliance is returned to the customer.

For Service Manuals Contact
MAURITRON TECHNICAL SERVICES
8 Cherry Tree Rd, Chinnor
Oxon OX9 4QY
Tel: 01844-351694 Fax: 01844-352554
Email: enquiries@mauritron.co.uk

X13-720X-XX A/6

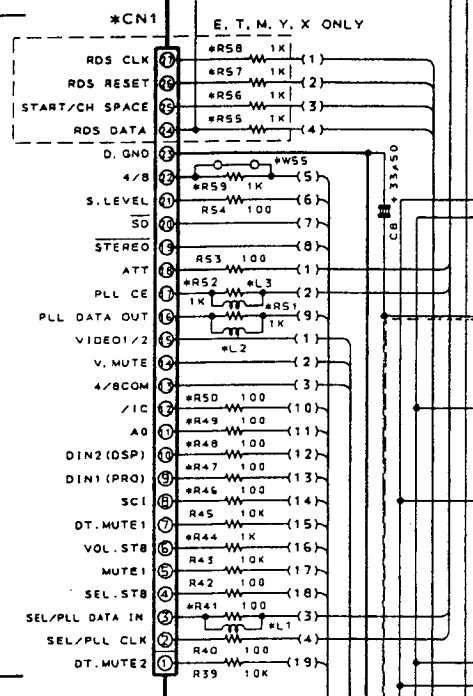
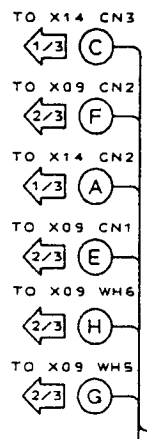
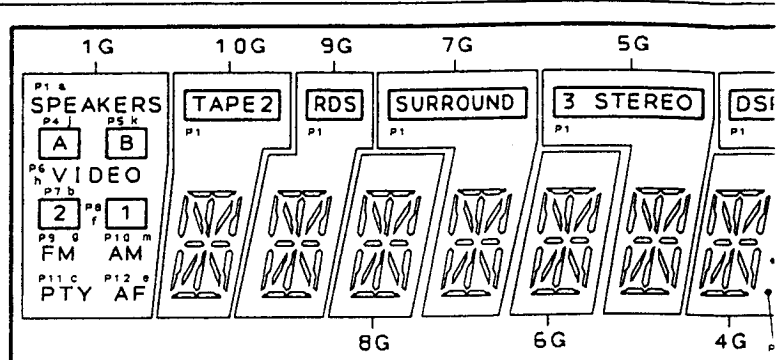
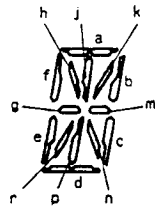

For Service Manuals Contact
MAURITRON TECHNICAL SERVICES
 8 Cherry Tree Rd, Chinnor
 Oxon OX9 4QY
 Tel: 01844-351694 Fax: 01844-352554
 Email: enquiries@mauritron.co.uk

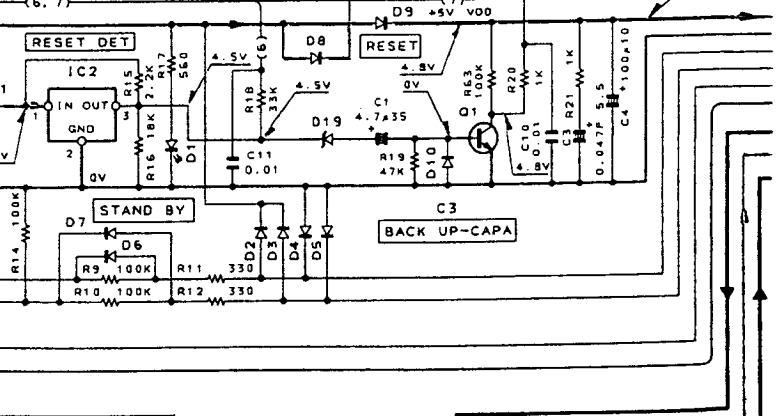
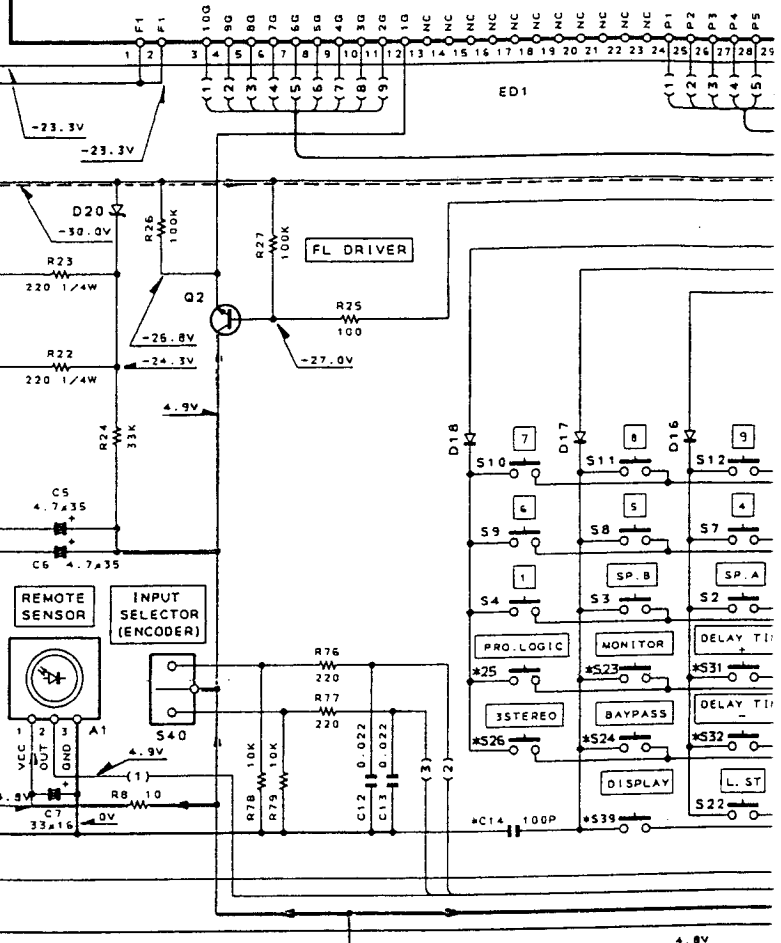
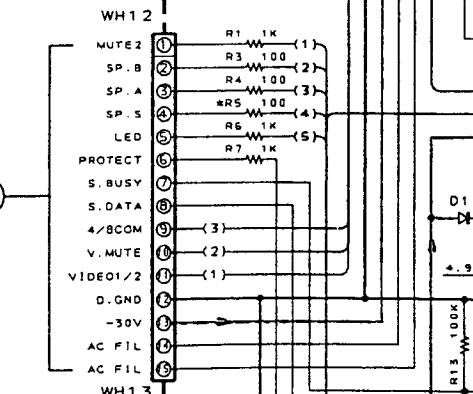

THE QUALITY OF
 THIS PAGE IS
 THE BEST THAT
 IS AVAILABLE

X A/6

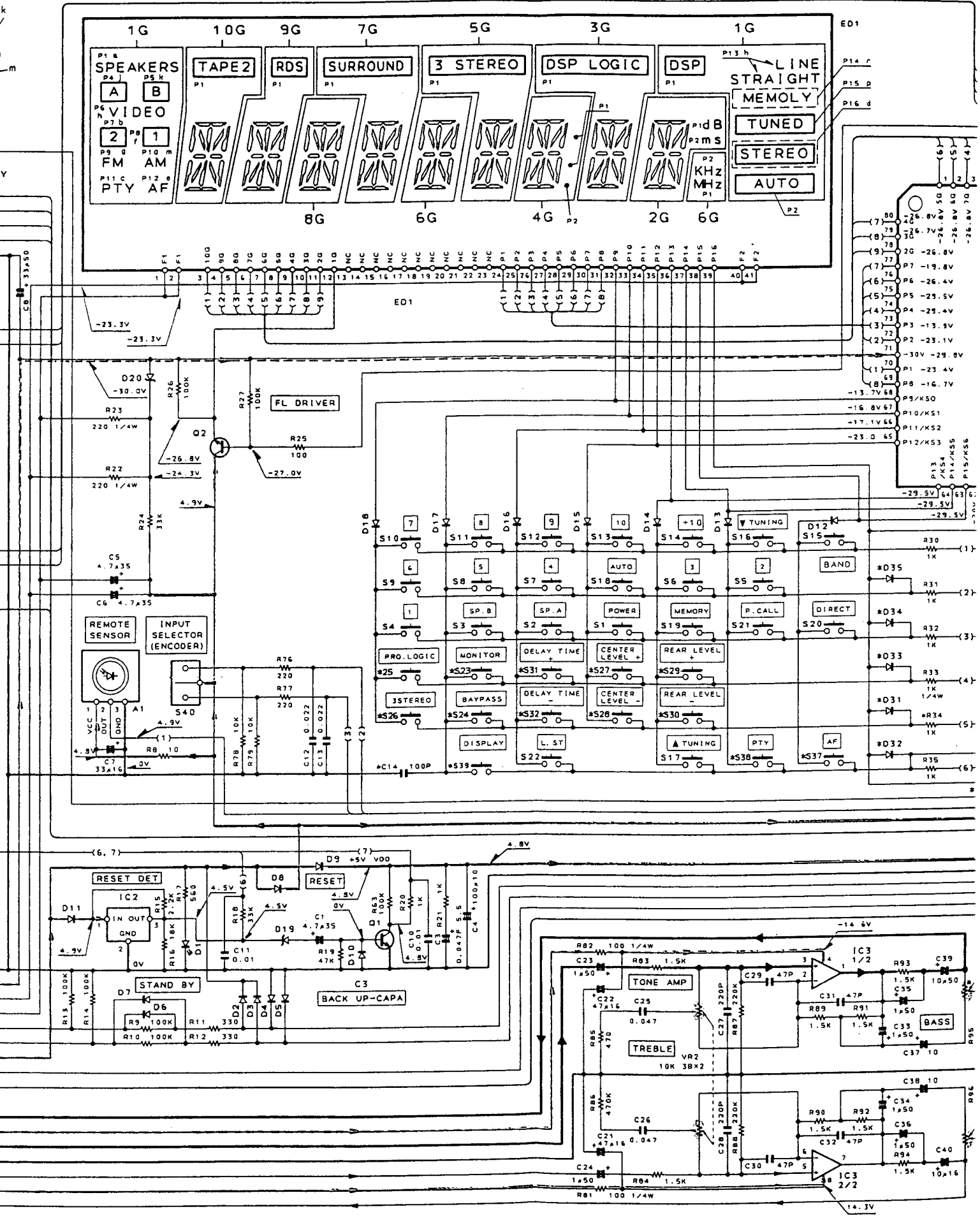

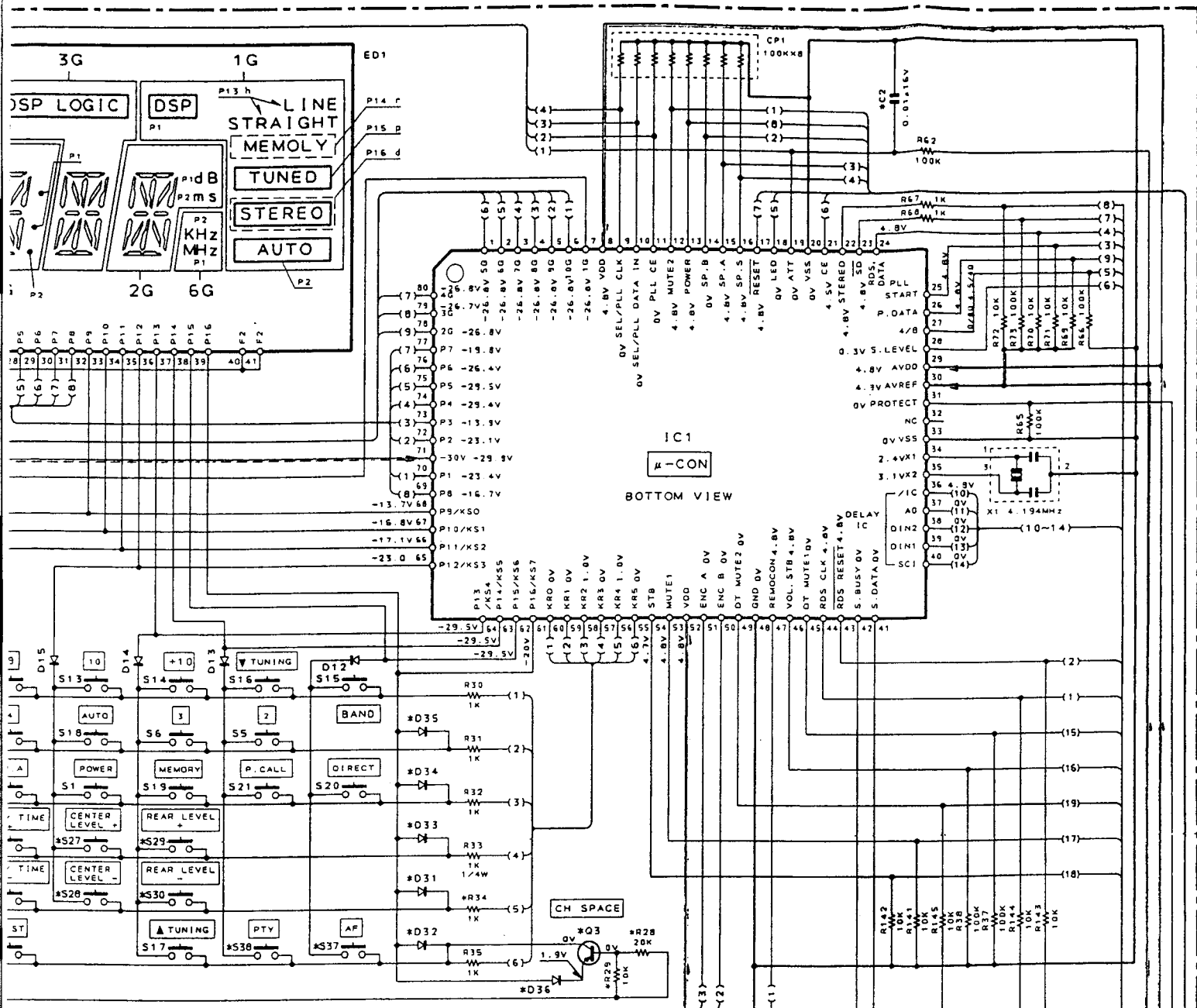

For Service Manuals Contact
MAURITRON TECHNICAL SERVICES
 8 Cherry Tree Rd, Chinnor
 Oxon OX9 4QY
 Tel: 01844-351694 Fax: 01844-352554
 Email: enquiries@mauritron.co.uk

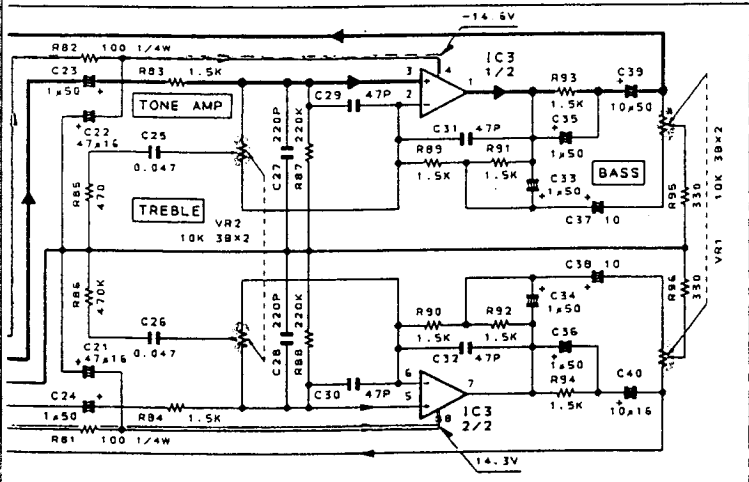

X13 A/6

ABB	UNIT	REF NO	Q3	D31	D32	D33	D36	D34	D35	C2, C14
K, P	0-10		NO	YES	NO	NO	NO	YES	NO	NO
M	0-21		YES	NO	NO	NO	YES	YES	NO	NO
Y	2-91		YES	NO	NO	NO	YES	YES	NO	NO
X	0-71		NO	NO	YES	NO	NO	YES	NO	NO
E	2-71		NO	NO	YES	YES	NO	NO	YES	YES
T	0-51		NO	NO	YES	YES	NO	YES	NO	YES

X13 A/6

ABB	UNIT	REF NO	R5, R34, R44, R46-50 R119, R120	R28, 29	R41, 51, 52 R55-58	R59	R104	S37-39 W55	S
K, P	0-10		YES	NO	NO	YES	YES	NO	
M	0-21		YES	YES	NO	YES	NO	NO	
Y	2-91		YES	YES	NO	YES	NO	NO	
X	0-71		YES	NO	NO	YES	NO	NO	
E	2-71		NO	NO	YES	NO	NO	YES	
T	0-51		YES	NO	YES	NO	NO	YES	

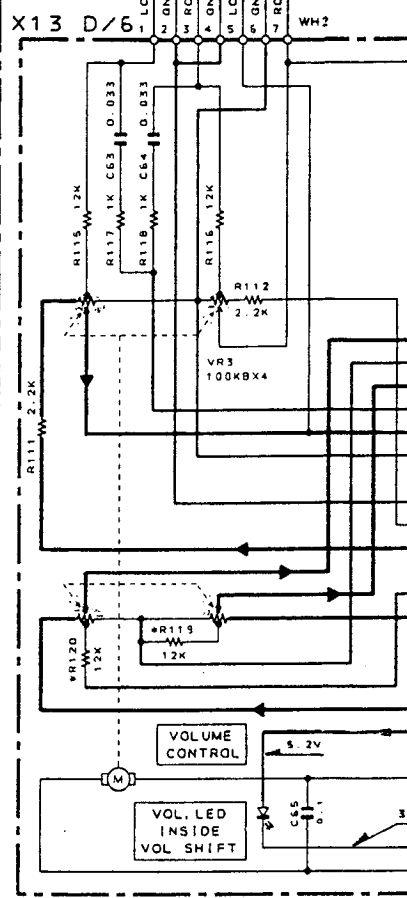
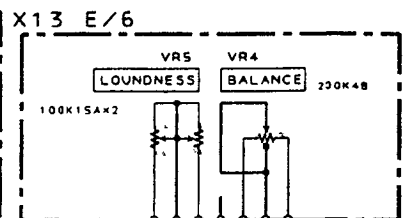
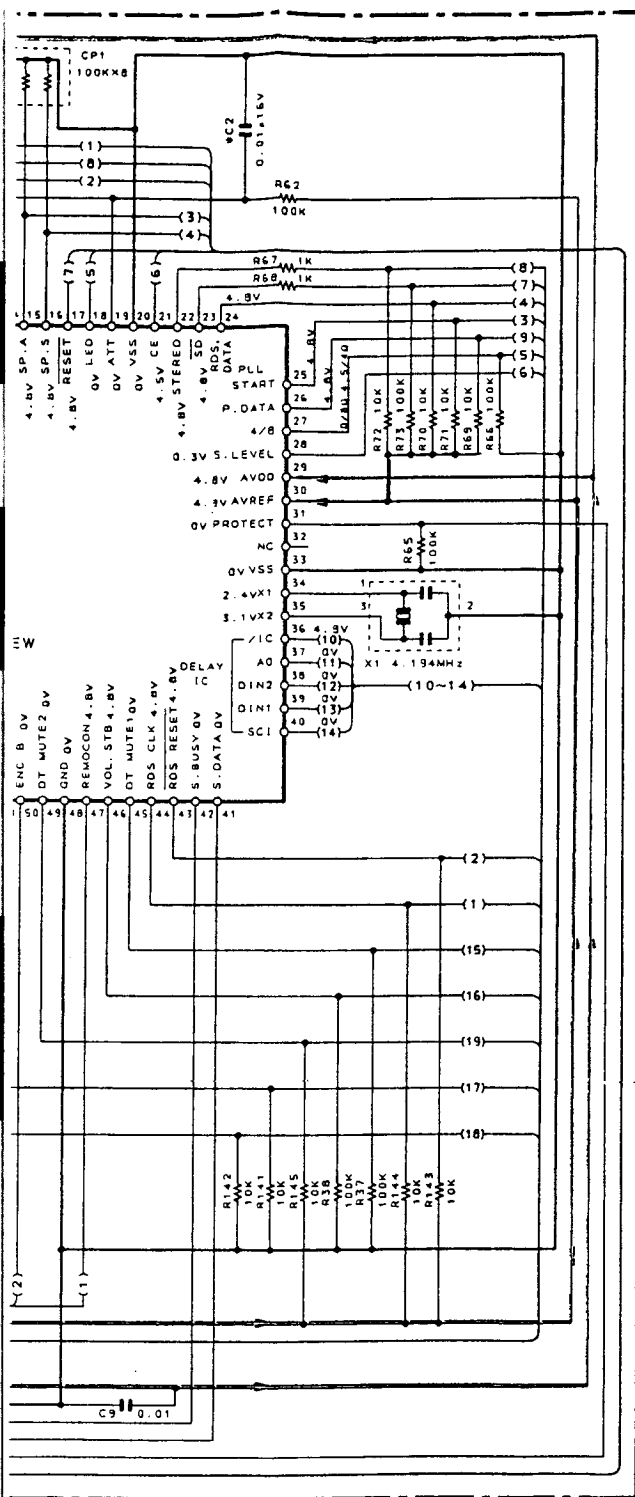

- X13-720X-XX
- IC1 : PD78044GF-021
 - IC2 : PST529C
 - IC3 : NJM4565L
- Q1, 2 : 2SC1740S (Q, R) or 2SC2785
- Q3 : 2SA933S (Q, R) or 2SA1175 (I)
- Q4 : 2SC2083 (L, K)
- Q5 : 2SC3940A (R, S)
- D1 : B30-1291-05
- D2~18 : HSS104 or ISS133
- 31~35, 44
- D19 : HZS2.7N (B2) or RD2.7ES (B)
- D20 : HZS5.1N (B2) or RD5.1ES (B)
- D40~43 : SS6888 or ISR139-100
- D45 : HZS6.2N (B2) or RD6.2ES (B)
- ED1 : 10-MT-58GK
- A1 : W02-1129-05 or W02-1046

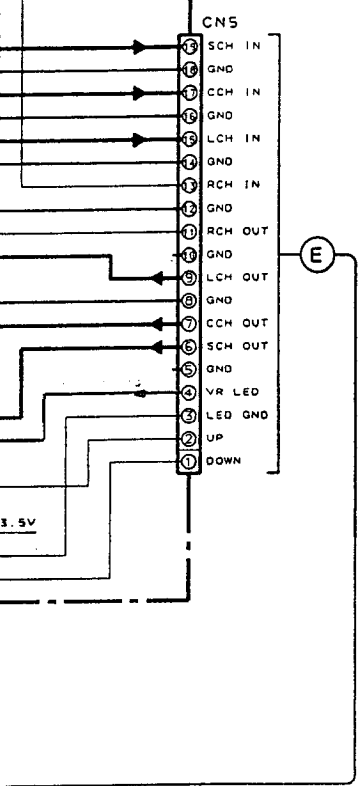

THE QUALITY OF THIS PAGE IS THE BEST THAT IS AVAILABLE

EF NO	Q3	D31	D32	D33	D36	D34	D35	C2, C14
	NO	YES	NO	NO	NO	YES	NO	NO
	YES	NO	NO	NO	YES	YES	NO	NO
	YES	NO	NO	NO	YES	YES	NO	NO
	NO	NO	YES	NO	NO	YES	NO	NO
	NO	NO	YES	YES	NO	NO	YES	YES
	NO	NO	YES	YES	NO	YES	NO	YES

EF NO	R5, R34, R44, R46~50 R119, R120	R28, 29	R41, 51, 52 R55~58	R59	R104	S37~39 W55	S24~32	L1~3
	YES	NO	NO	YES	YES	NO	YES	YES
	YES	YES	NO	YES	NO	NO	YES	YES
	YES	YES	NO	YES	NO	NO	YES	YES
	YES	NO	NO	YES	NO	NO	YES	YES
	NO	NO	YES	NO	NO	YES	NO	NO
	YES	NO	YES	NO	NO	YES	YES	NO

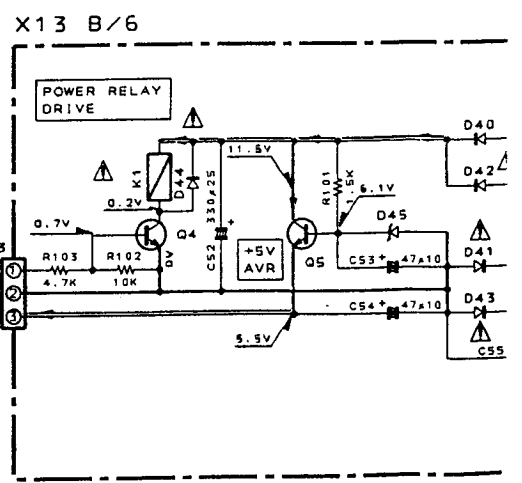

X13-720X-XX

- IC1 : PD78044GF-021
- IC2 : PST529C
- IC3 : NJM4565L

- Q1, 2 : 2SC1740S (Q, R) or 2SC2785 (F, E)
- Q3 : 2SA933S (Q, R) or 2SA1175 (F, E)
- Q4 : 2SC2089 (L, K)
- Q5 : 2SC3940A (R, S)

- D1 : B30-1291-05
- D2~18 : HSS104 or ISS133
- 31~35, 44
- D19 : HZS2.7N (B2) or RD2.7ES (B2)
- D20 : HZS5.1N (B2) or RDS.1ES (B2)
- D40~43 : S56888 or ISR139-100
- D45 : HZS6.2N (B2) or RD6.2ES (B2)
- ED1 : 10-MT-58GK
- A1 : W02-1129-05 or W02-1046-05

TYPE K, P

(X13-) (B/6)

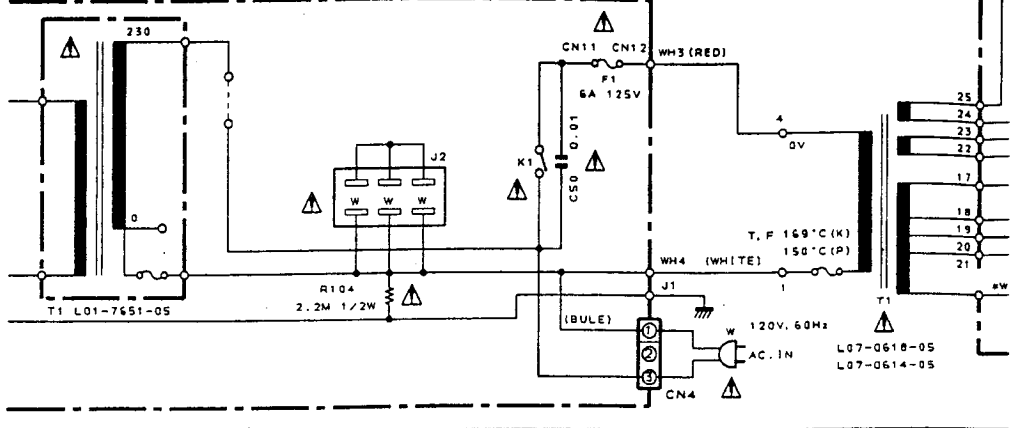

TYPE E, T, X

(X13-) (B/6)

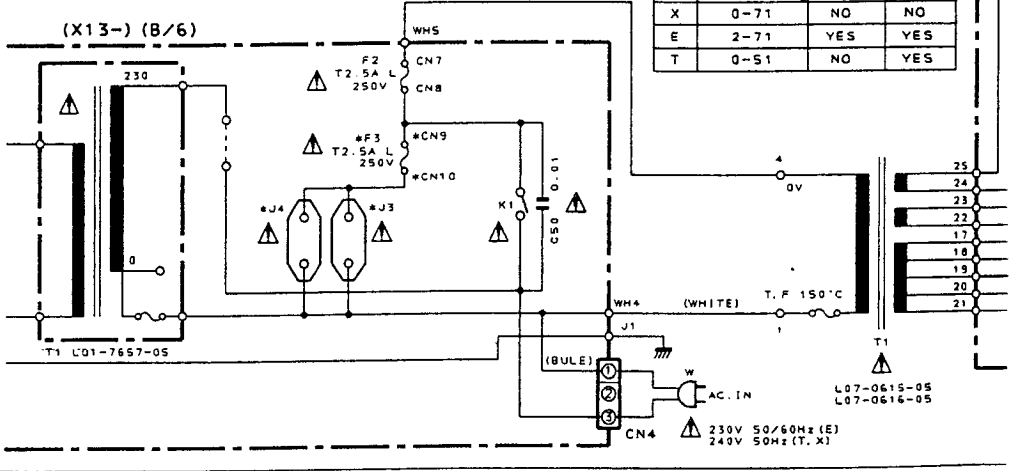

For Service Manuals Contact
MAURITRON TECHNICAL SERVICES
 8 Cherry Tree Rd, Chinnor
 Oxon OX9 4QY
 Tel: 01844-351694 Fax: 01844-352554
 Email: enquiries@mauriton.co.uk

X13 C/6

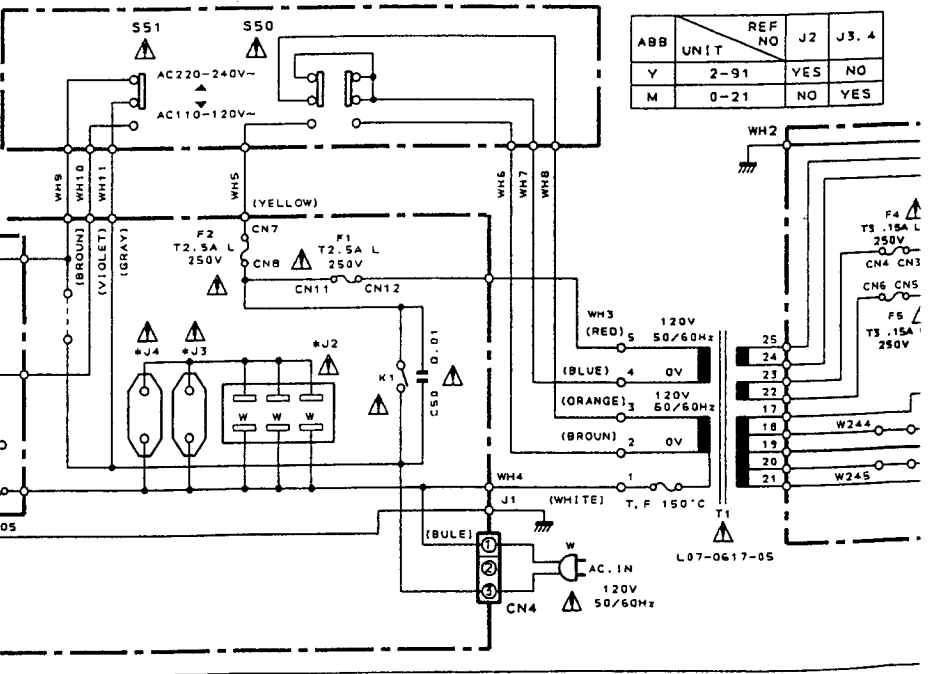

B/6

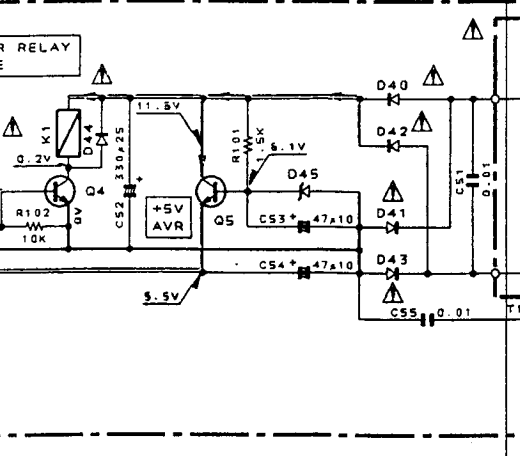

DESTINATION	K	P
Ref.No.	0-10	1-01
F6.7	W244 W245	8A 250V

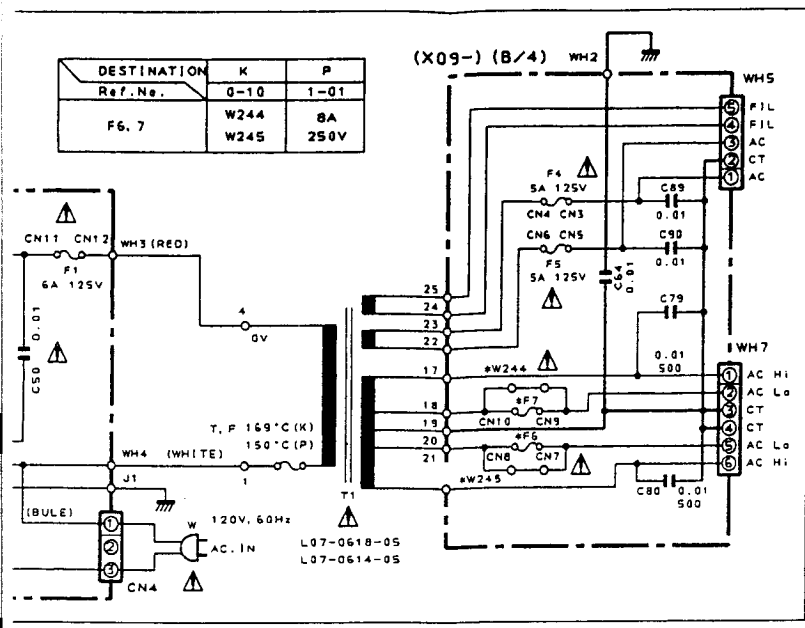

For Service Manuals Contact
MAURITRON TECHNICAL SERVICES
 8 Cherry Tree Rd, Chinnor
 Oxon OX9 4QY
 Tel: 01844-351694 Fax: 01844-352554
 Email: enquiries@mauritron.co.uk

ABB	UNIT	REF NO	F3, CN9 CN10	J3, J4
X	0-71	NO	NO	NO
E	2-71	YES	YES	YES
T	0-51	NO	NO	YES

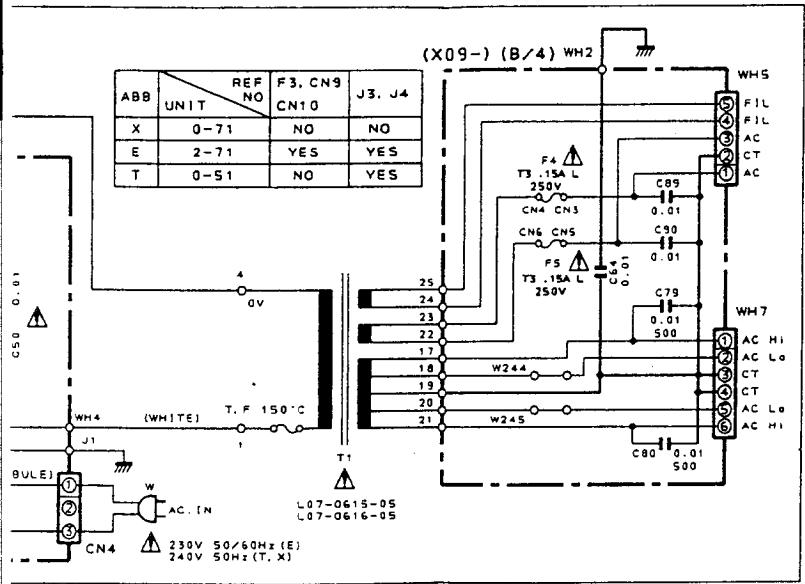

DC voltages are as measured with a high impedance volt-
 meter. Values may vary slightly due to variations between indi-
 vidual instruments or/and units.

Les tensions c.c. doivent être mesurées avec un voltmètre à
 haute impédance. Les valeurs peuvent différer légèrement du
 fait des variations inhérentes aux appareils et aux instruments
 de mesure individuels.

Die angegebenen Gleichspannungswerte wurden mit einem
 hochohmigen Spannungsmesser gemessen. Dabei schwanken
 die Meßwerte aufgrund von Unterschieden zwischen ein-
 zeln Instrumenten oder Geräten u. U. geringfügig.

TYPE Y, M

ABB	UNIT	REF NO	J2	J3, 4
Y	2-91	YES	NO	NO
M	0-21	NO	YES	YES

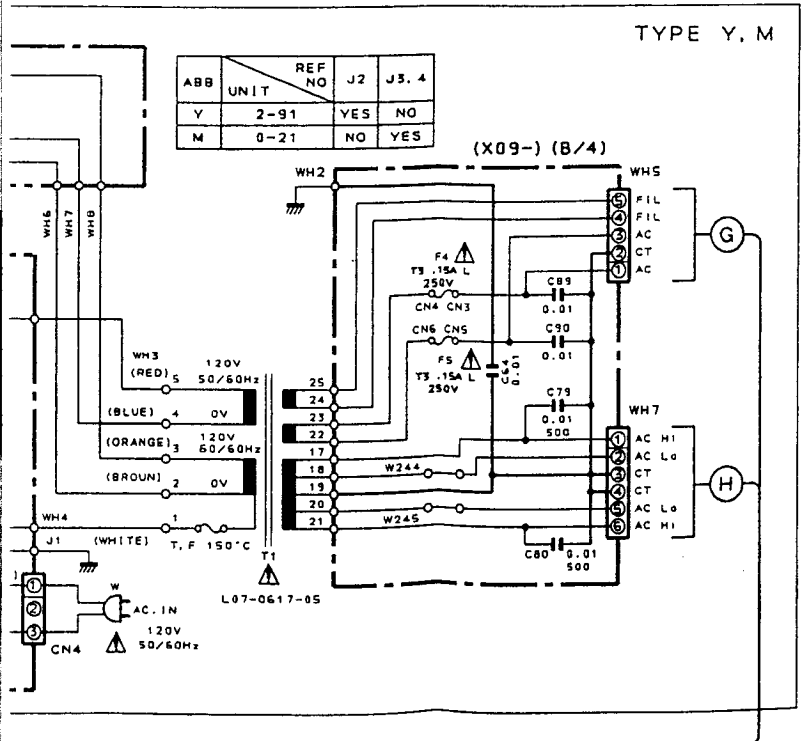

CAUTION: For continued safety, replace safety critical
 components only with manufacturer's recommended parts (refer to
 parts list). Δ Indicates safety critical components. To reduce the
 risk of electric shock, leakage-current or resistance measurements
 shall be carried out (exposed parts are acceptably insulated from
 the supply circuit) before the appliance is returned to the custom-
 er.

**THE QUALITY OF
 THIS PAGE IS
 THE BEST THAT
 IS AVAILABLE**

- SIGNAL LINE
- GND LINE
- +B LINE
- - - -B LINE

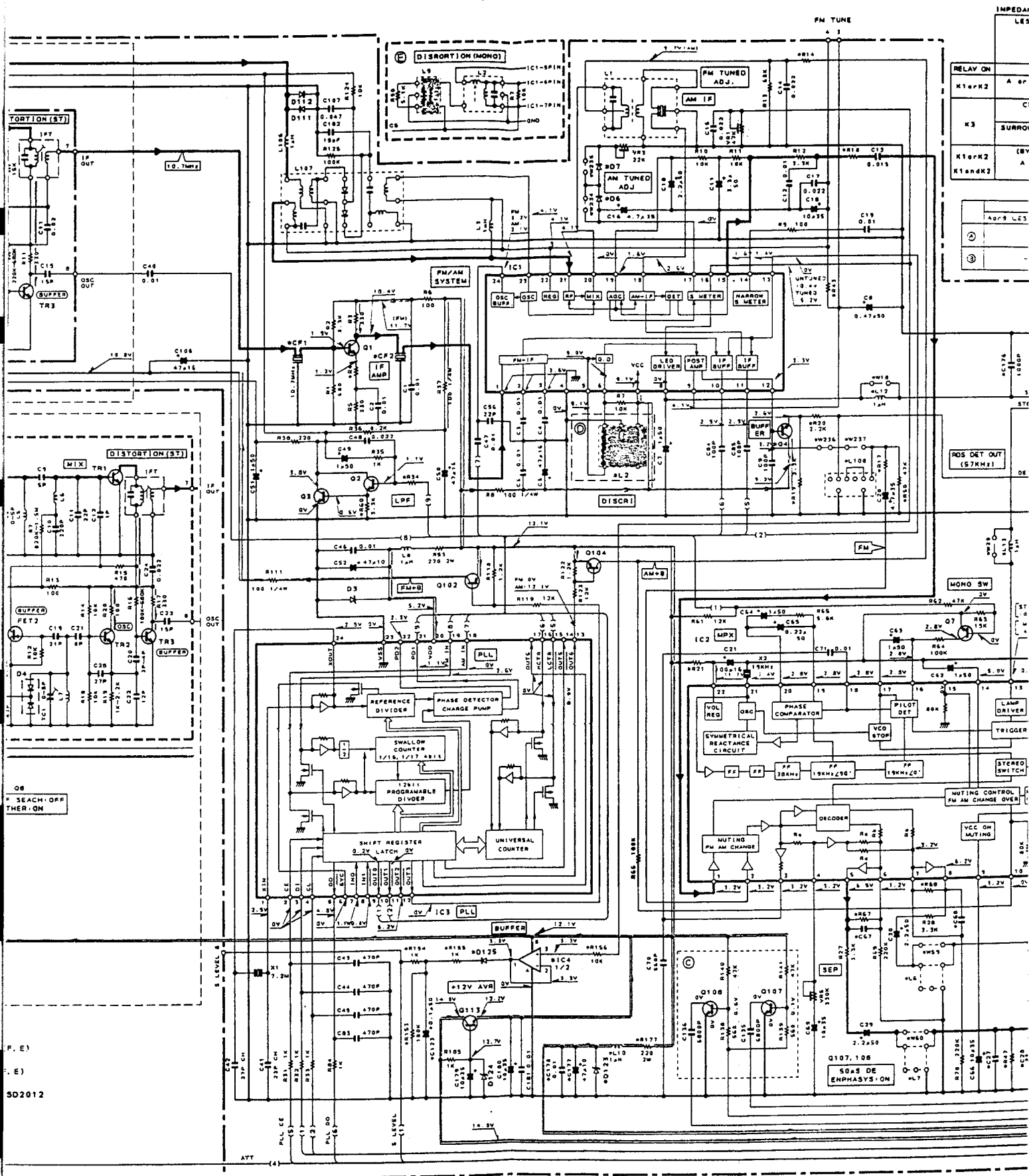

IMPEDA
LES

RELAY ON	
K16/K2	A 4P
	C1
K3	SURRO
K16/K2	(BY
K16/K3	A
	Adp-3 L23
	(2)
	(3)

F. E)
E)
SD2012

R34	R43	R46	R47	R50	R60	R67	R68	R109	R110	R153	R154	R155	R156	R160	R162	R163	R164	R165	R166	R167	R168	R169	R170	R171	R172	R173	R174	R177	C26	C67	C68	C123	C172	C174	C177	C177	C178	L2	L6	L7	L9	L10	L12	L13	L10	
10K	15K	33K	NO	3.3K	100K	W1	NO	NO	NO	NO	NO	NO	NO	NO	NO	NO	NO	NO	NO	NO	NO	NO	NO	NO	NO	NO	NO	9.018	100P	NO	NO	NO	1000P	NO	NO	NO	NO	L30-0439	NO	NO	NO	NO	YES	YES	NO	
10K	33K	33K	NO	3.3K	100K	W1	NO	NO	NO	NO	NO	NO	NO	NO	NO	NO	NO	NO	NO	NO	NO	NO	NO	NO	NO	NO	NO	NO	0.015	100P	NO	NO	NO	NO	NO	NO	NO	NO	L30-0494	NO	NO	NO	NO	YES	YES	NO
1K	33K	3.3K	47K	NO	220K	4.7K	10K	100K	1K	1K	10K	1.2K	62	18	620	22K	100K	47K	470	180	10K	100K	220	2W	3500P	220P	0.1	33P	1000P	NO	47.2	0.01	L30-0484	YES	L30	0486	YES	W18	W25	YES	YES					

THE QUALITY OF THIS PAGE IS THE BEST THAT IS AVAILABLE

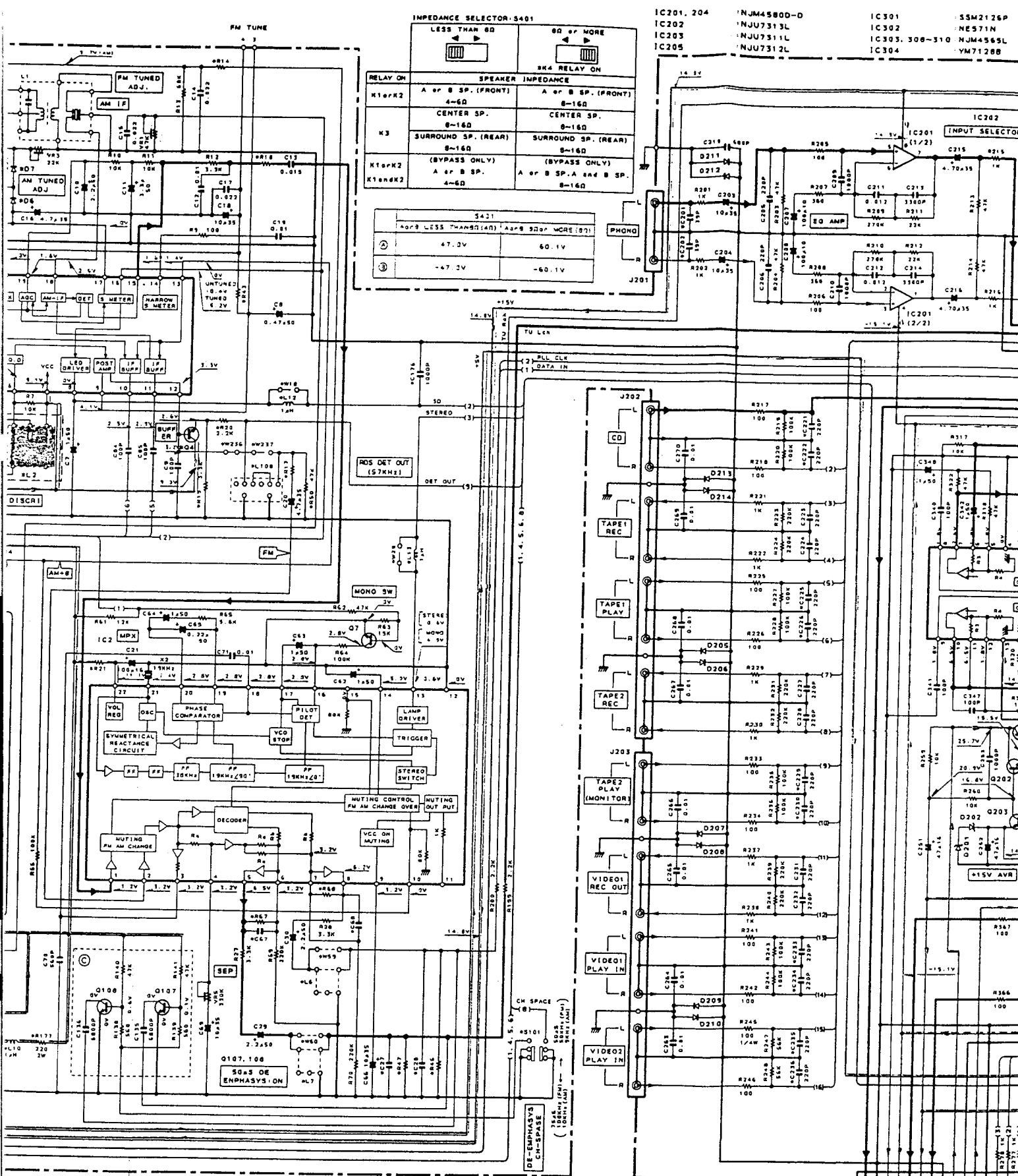

C67	C123	C172	C173	C174	C177	C177	C178	L2	L6	L7	L9	L10	L12	L13	L104	Q4	Q107	Q108	D6	D117-121, 125	D123	CF1. 2	IC4	S101	DT1
100P	NO	NO	NO	1000P	NO	NO	NO	L30-0435	NO	NO	NO	NO	YES	YES	NO	NO	NO	NO	NO	NO	NO	L72-0531	NO	NO	W02-1042
100P	NO	NO	NO	1000P	NO	NO	NO	L30-0494	NO	NO	NO	NO	YES	YES	NO	NO	NO	NO	NO	NO	NO	L72-0531	NO	YES	W02-1042
100P	NO	NO	NO	1000P	NO	NO	NO	L30-0494	NO	NO	NO	NO	YES	YES	NO	NO	NO	NO	NO	NO	NO	L72-0531	NO	NO	W02-1042
220P	0.1μ	33P	1000P	NO	47μ10	0.01	L30-0484	YES	L30	0485	YES	W16	W29	YES	YES	NO	YES	YES	YES	YES	YES	L73-0536	YES	NO	W02-1041

For Service Manuals Contact
MAURITRON TECHNICAL SERVICES
 8 Cherry Tree Rd, Chinnor
 Oxon OX9 4QY
 Tel: 01844-351694 Fax: 01844-352554
 Email: enquiries@mauritron.co.uk

204	IC301	SSM2126P	IC305	M5238AL	Q201, 204	2502061 or 2502012 or 2502374	Q205, 206, 212
	IC302	NE571N	IC306	LA2730	Q202, 203, 209	25C17405 (Q, R) or 25C2458 (Y, GR) or	Q207, 208,
	IC303, 308-310	NUM4565L	IC307	TC9215P	210, 213, 303	25C2785 (P, E) or 25C3311A (Q, R)	Q211, 301
	IC304	YM7120B			304, 306		

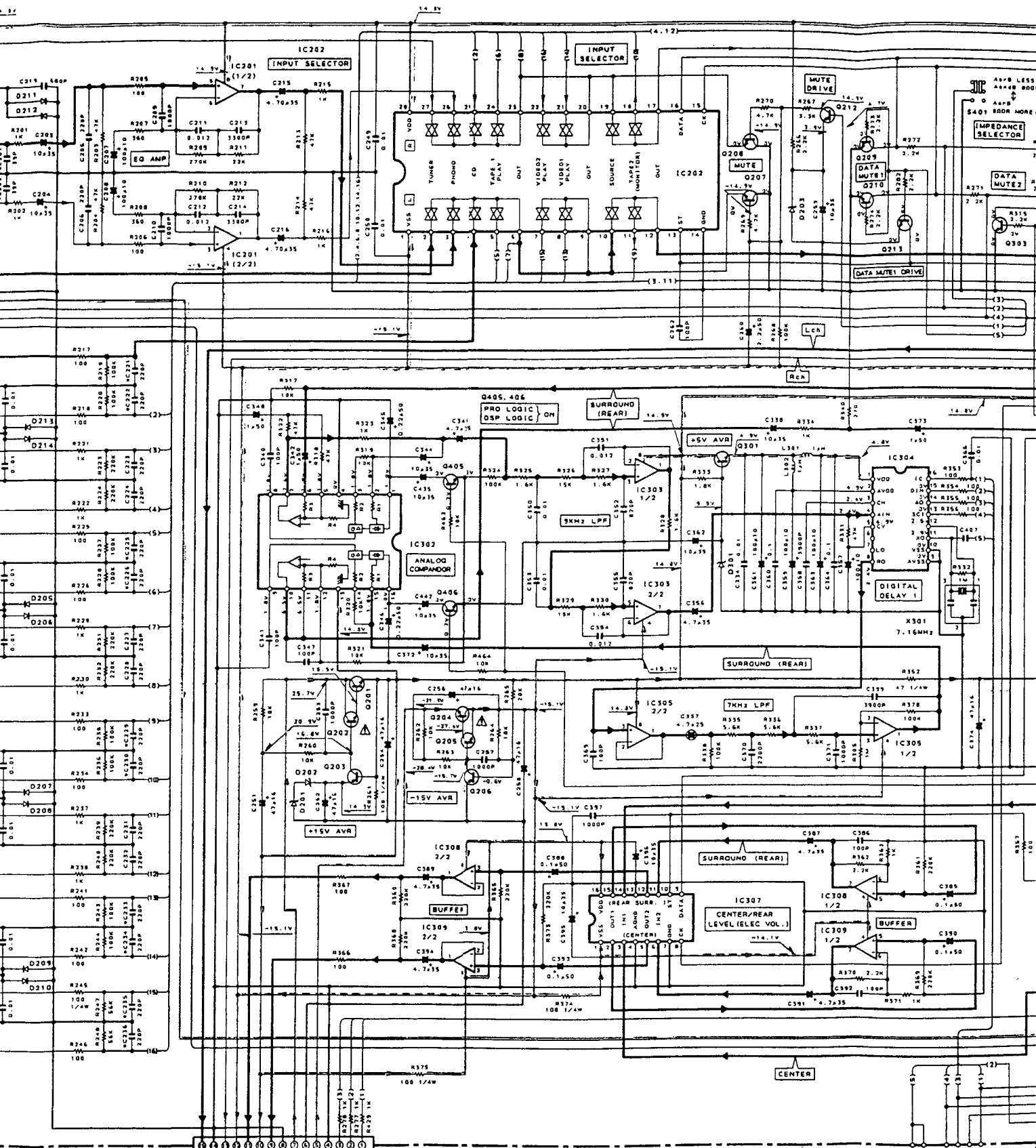

IC4	S101	DT1
NO	NO	W02-1042
NO	YES	W02-1042
NO	NO	W02-1042
YES	NO	W02-1041

UNIT	ABB	REF. NO.	CN4, C201, 202, 221, 222, 225, 226, 229, 230, 233-236, 241, 242	CN3
0-10	K, P	USA, CANADA	NO	23P
0-21	Y, M	PX, OTHER AREAS	NO	27P
0-71	X	AUSTRALIA	NO	27P
2-71	T, E	ENGLAND, EUROPE	YES	27P

THE QUALITY OF THIS PAGE IS THE BEST THAT IS AVAILABLE

(X09-375X-XX) (A/4)

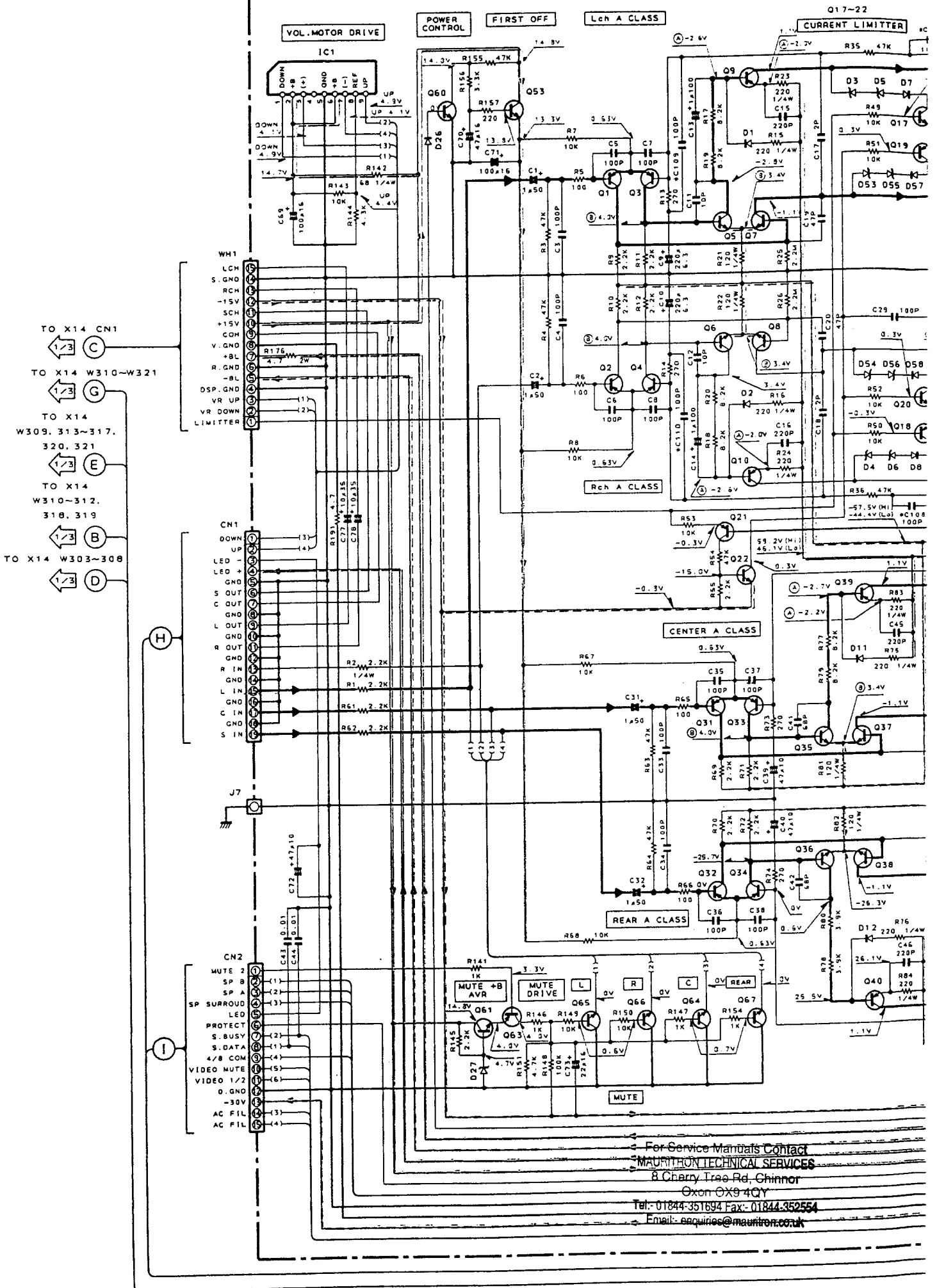

For Service Manuals Contact
MAURITON TECHNICAL SERVICES
 8 Cherry Tree Rd, Chinnor
 Oxon OX9 4QY
 Tel: 01844-351694 Fax: 01844-352554
 Email: enquiries@mauriton.co.uk

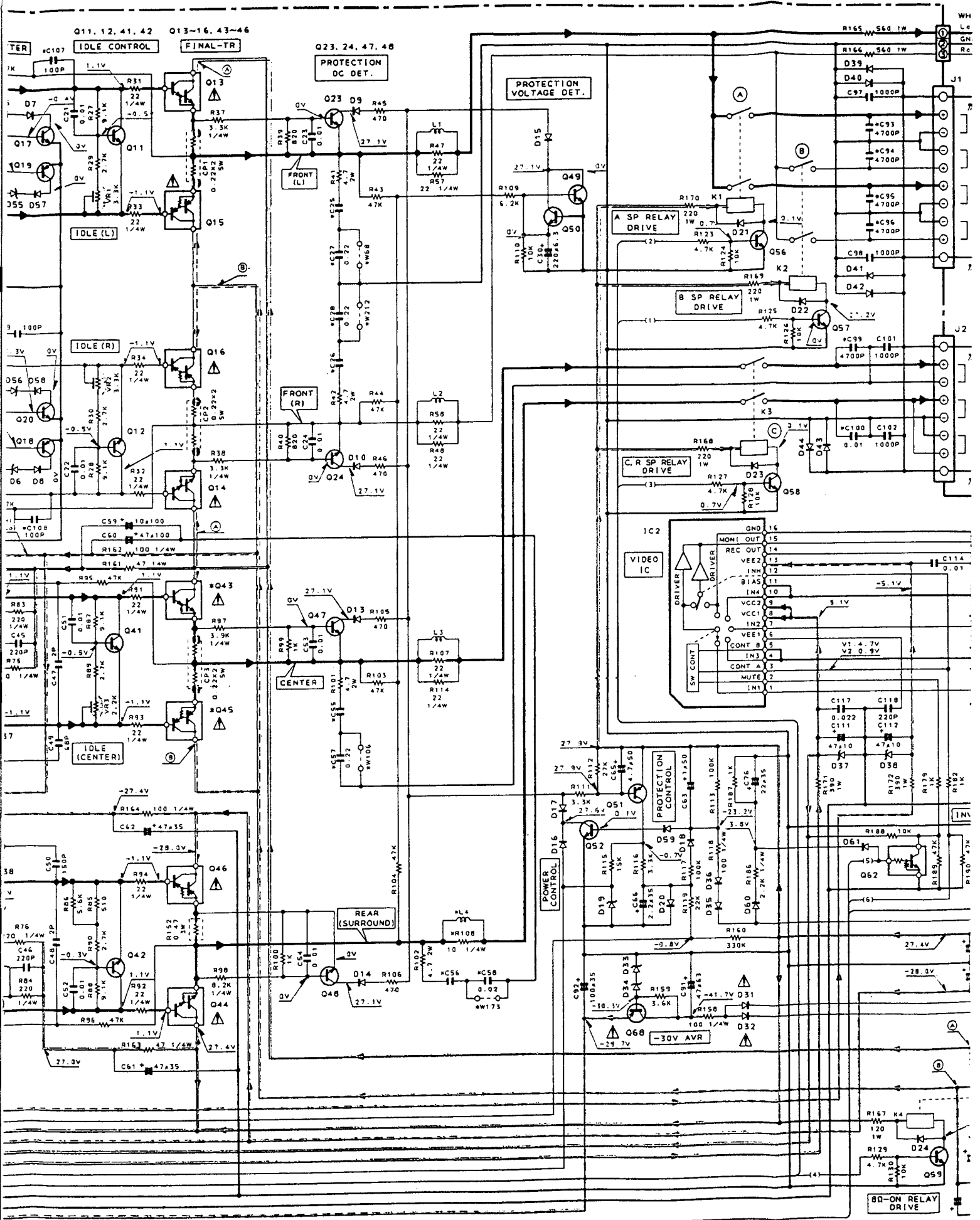

(X09-) (C/4)

X13 F/6

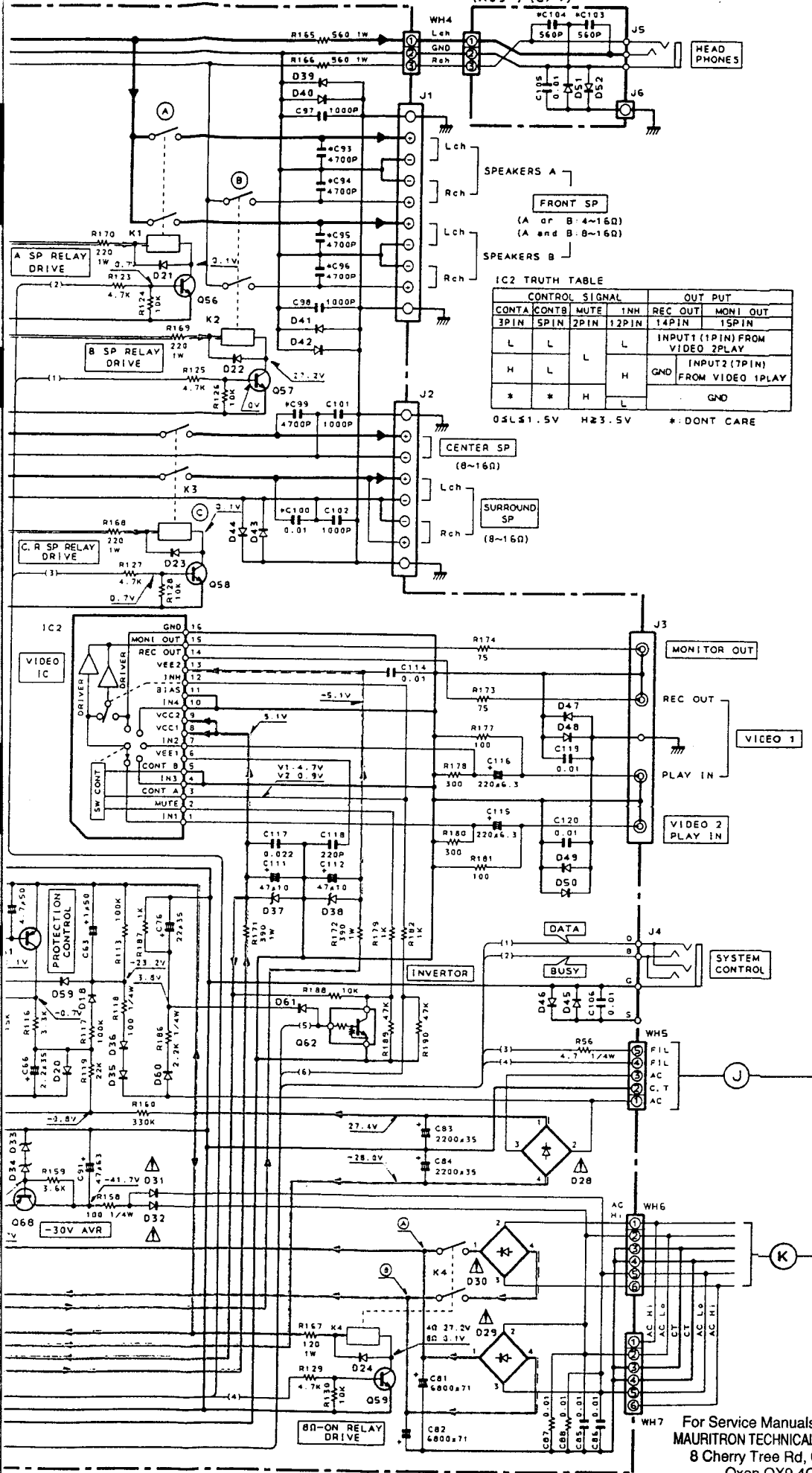

IC2 TRUTH TABLE

CONTROL SIGNAL				OUT PUT	
CONTA	CONTB	MUTE	INH	REC OUT	MONI OUT
3PIN	5PIN	2PIN	12PIN	14PIN	15PIN
L	L	L	L	INPUT1 (11PIN) FROM VIDEO 2PLAY	
H	L	L	H	GND	INPUT2 (7PIN) FROM VIDEO 1PLAY
*	*	H	L		GND

0 ≤ L ≤ 1.5V H ≥ 3.5V *: DONT CARE

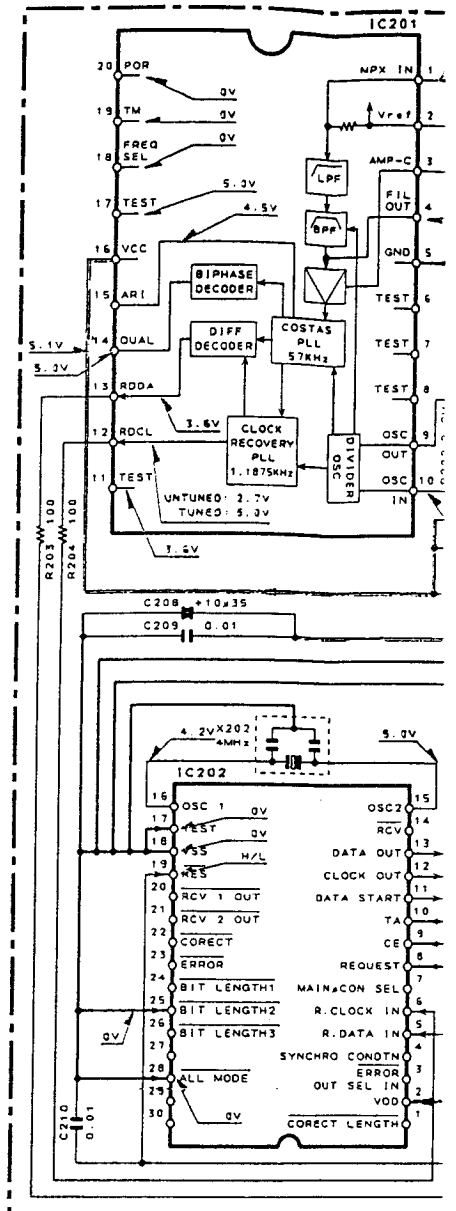

- X09-375X-XX
- IC1 : TA8409S
 - IC2 : CXA1558L
- Q1~4, 19, 20, 31~34, 40, 51 : 2SA992 (F. E)
- Q5~8, 35, 37 : 2SC2631 (R. S)
- Q9, 10, 39 : 2SA1123 (R. S)
- Q11, 12, 41, 42 : 2SC4137F19 (V. W)
- Q13, 14 : 2SD2449LB or 2S
- Q15, 16 : 2SB1594LB or 2S
- Q17, 18, 23, 24, 36, 38, 47~50, 52 : 2SC1845 (F. E)
- Q21, 63 : 2SA933S (Q. R) or
- Q22, 53, 56~61 : 2SC1740S (Q. R) or
- *Q43 : 2SD2340BT
- Q44 : 2SD2340BT
- *Q45 : 2SD2340BT
- Q46 : 2SB1531BT
- Q62 : UN4212 or DTC124
- Q64~67 : 2SC2878 (B)
- D1, 2, 7~18, 20~24, 26, 35, 36, 57~61 : HSS104A or 1SS13
- D3, 4, 53, 54 : HZS11N (B2) or F
- D5, 6, 55, 56 : HZS13N (B2) or F
- D19, 25, 37, 38 : HZS5.1N (B2) or F
- D27 : HZS4.7N (B2) or F
- D28 : D3SBA20F03 or F
- D29, 30 : D5SBA20F03 or F
- D31, 32 : S5688B or 1SR13
- D33 : HZS15N (B2) or RC
- D34 : HZS16N (B2) or R
- D39~52 : HSS104 or 1SS13

For Service Manuals Contact
MAURITRON TECHNICAL SERVICES
 8 Cherry Tree Rd, Chinnor
 Oxon OX9 4QY
 Tel: 01844 351604 Fax: 01844 352554
 Email: enquiries@mauritron.co.uk

X13 F/6

X14 B/2

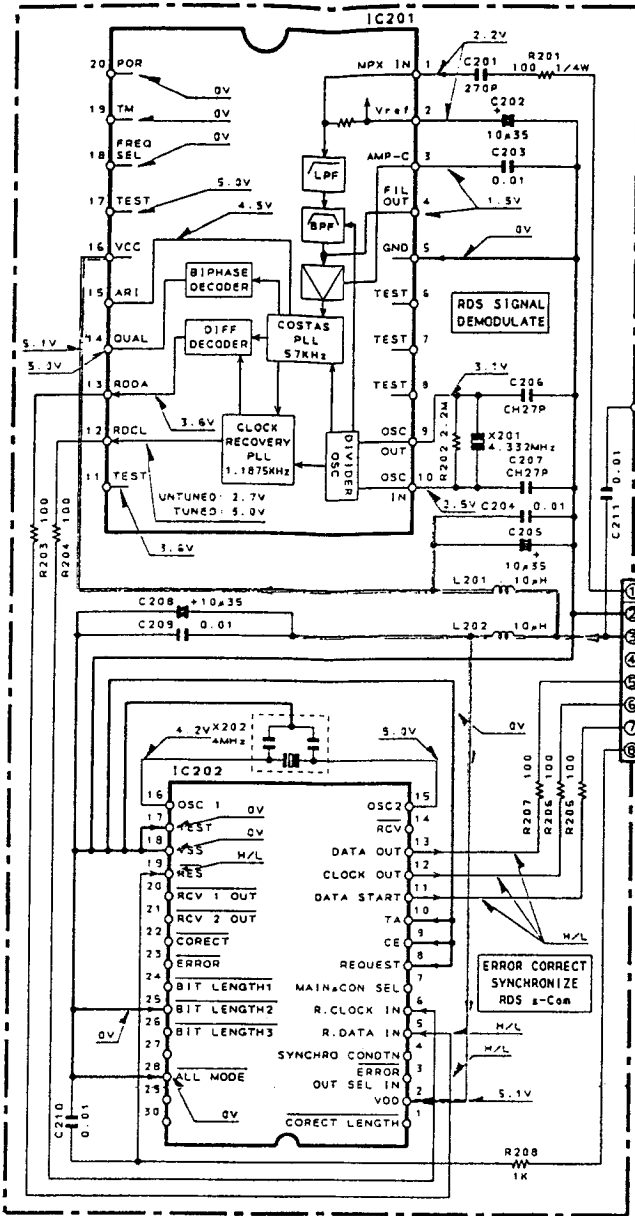

X13 F/6
 IC201 : TDA7330A
 IC202 : LC6543H-4600

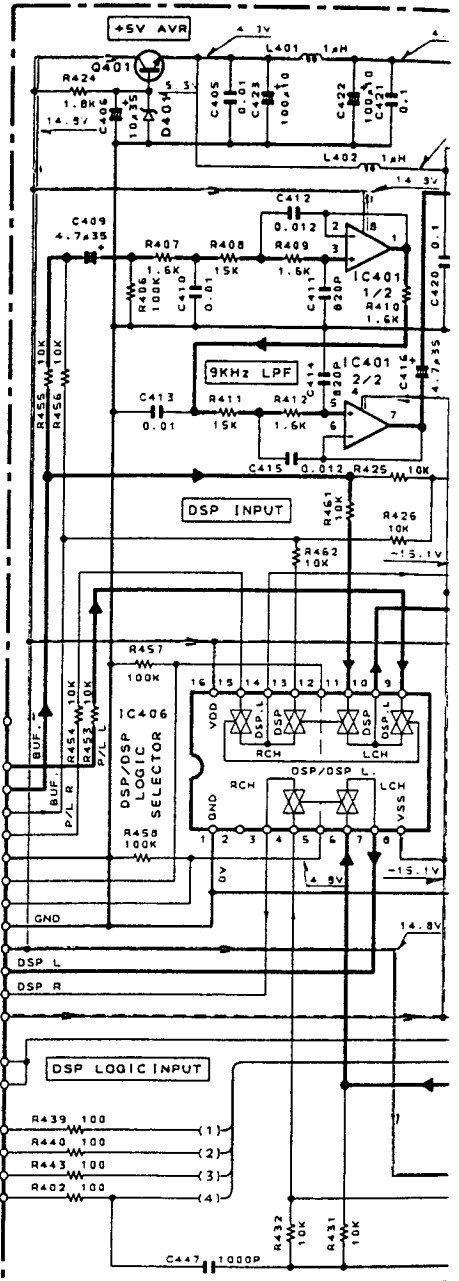

X09-375X-XX

IC1 : TAB409S
 IC2 : CXA155BL

- Q1~4, 19, 20, 31~34, 40, 51 : 2SA992 (F, E)
- Q5~8, 35, 37 : 2SC2631 (R, S)
- Q9, 10, 39 : 2SA1123 (R, S)
- Q11, 12, 41, 42 : 2SC4137F19 (V, W)
- Q13, 14 : 2SD2449LB or 2SD2222BT
- Q15, 16 : 2SB1594LB or 2SB1470BT
- Q17, 18, 23, 24, 36, 38, 47~50, 52 : 2SC1845 (F, E)
- Q21, 63 : 2SA933S (Q, R) or 2SA1175 (F, E)
- Q22, 53, 56~61 : 2SC1740S (Q, R) or 2SC2785 (F, E)
- *Q43 : 2SD2340BT
- Q44 : 2SD2340BT
- *Q45 : 2SD2340BT
- Q46 : 2SB1531BT
- O62 : UN4212 or DTC124ES
- Q64~67 : 2SC2878 (B)

- D1, 2, 7~18, 20~24, 26, 35, 36, 57~61 : HSS104A or 1SS131
- D3, 4, 53, 54 : HZS11N (B2) or RD11ES (B2)
- D5, 6, 55, 56 : HZS13N (B2) or RD13ES (B2)
- D19, 25, 37, 38 : HZS5.1N (B2) or RDS.1ES (B2)
- D27 : HZS4.7N (B2) or RD4.7ES (B2)
- D28 : D3SBA20F03 or RBV-402LFA
- D29, 30 : D5SBA20F03 or RBV-602LFA
- D31, 32 : S5688B or 1SR139-100
- D33 : HZS15N (B2) or RD15ES (B2)
- D34 : HZS16N (B2) or RD16ES (B2)
- D39~52 : HSS104 or 1SS133

DESTINATION	K	P	T, E	Y, M, X
Ref. No.	0-10	1-01	2-71	0-21
C25, 26, 55, 56	0.1μ	0.1μ	0.22μ	0.1μ
C27, 28, 57, 58	NO	NO	YES	NO
C93, 94, 95, 96, 103, 104, 107~110	NO	NO	YES	NO
C107~110	NO	NO	YES	NO
R108	W169	W169	YES	W169
C99, 100 L4	NO	NO	YES	NO
W68, 106, 173, 212	YES	YES	NO	YES

DESTINATION	K	P	T, E	Y, M, X
Ref. No.	0-10	1-01	2-71	0-21
*Q43				
2SD2255BT	YES	NO	NO	NO
2SD2255BY*1				
2SD2384LB	NO	YES	YES	YES
*Q45				
2SB1493BT	YES	NO	NO	NO
2SB1493BT*1				
2SB1555LB	NO	YES	YES	YES

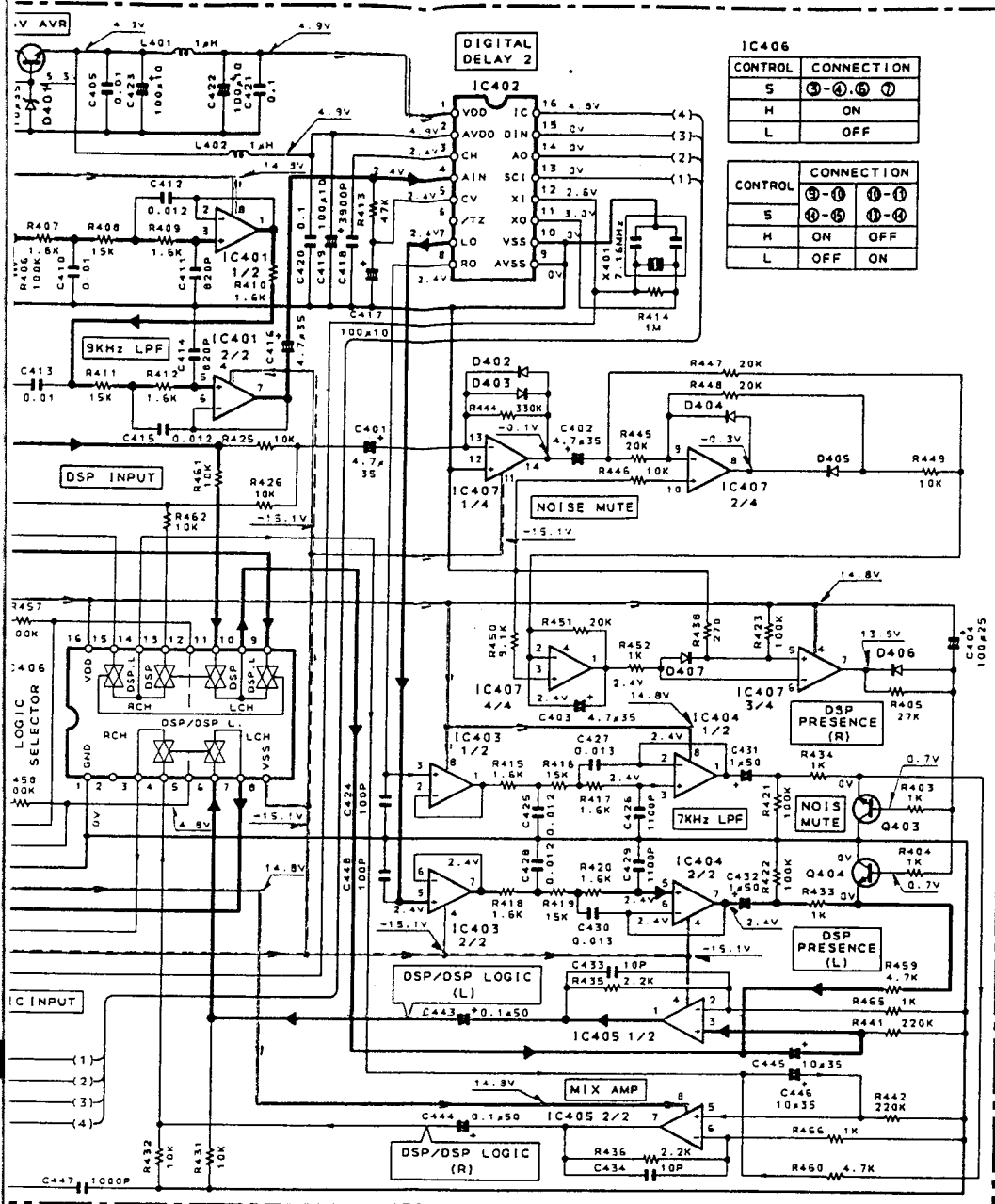

IC406

CONTROL	CONNECTION
S	③-④-⑤ ⑦
H	ON
L	OFF

CONTROL	CONNECTION
S	②-① ①-①
H	②-⑤ ①-④
L	OFF ON

For Service Manuals Contact
MAURITRON TECHNICAL SERVICES
 8 Cherry Tree Rd, Chinnor
 Oxon OX9 4QY
 Tel: 01844-351694 Fax: 01844-352554
 Email: enquiries@mauritron.co.uk

- X14 B/2
- IC401 : NJM4565L
 - IC402 : YM71288
 - IC403 : M5238AL
 - IC404, 405 : NJM4565L
 - IC406 : TC9215P
 - IC407 : μ PC4574C
-
- D401 : HZ55.6N (B2) or RDS.6ES (B2)
 - D402-407 : ISS133 or HSS104
-
- Q401 : 2SC2003 (L, K)
 - Q403, 404 : 2SC2878 (B)

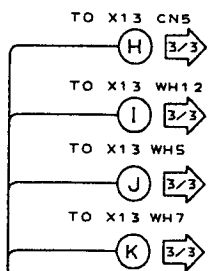

DC voltages are as measured with a high impedance voltmeter. Values may vary slightly due to variations between individual instruments or/and units.

Les tensions c.c. doivent être mesurées avec un voltmètre à haute impédance. Les valeurs peuvent différer légèrement du fait des variations inhérentes aux appareils et aux instruments de mesure individuels.

Die angegebenen Gleichspannungswerte wurden mit einem hochohmigen Spannungsmesser gemessen. Dabei schwanken die Meßwerte aufgrund von Unterschieden zwischen einzelnen Instrumenten oder Geräten u. U. geringfügig.

CAUTION: For continued safety, replace safety critical components only with manufacturer's recommended parts (refer to parts list). Δ Indicates safety critical components. To reduce the risk of electric shock, leakage-current or resistance measurements shall be carried out (exposed parts are acceptably insulated from the supply circuit) before the appliance is returned to the customer.

P	T, E	Y, M, X
0	1-01	2-71 0-21
1	0.1 μ	0.22 μ 0.1 μ
2	NO	YES NO
3	NO	YES NO
4	W169	YES W169
5	NO	YES NO
6	YES	NO YES

P	T, E	Y, M, X
1-01	2-71	0-21
NO	NO	NO
YES	YES	YES
NO	NO	NO
YES	YES	YES

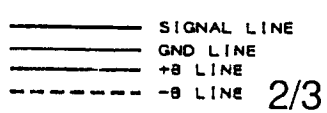

KR-V7050

KENWOOD

X13-719X-XX A/6

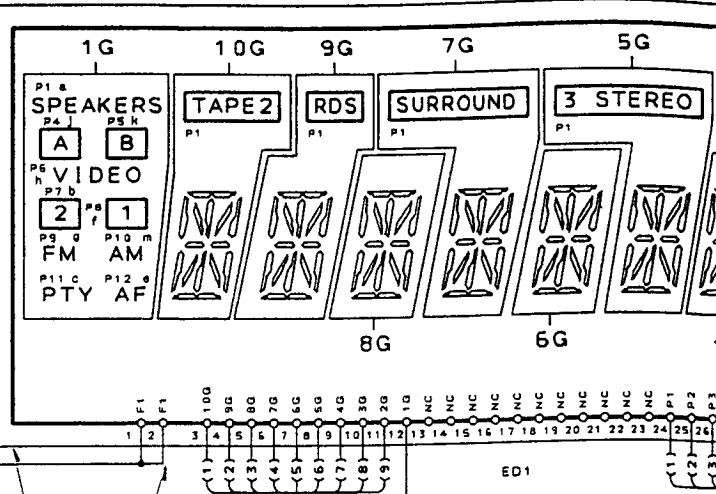
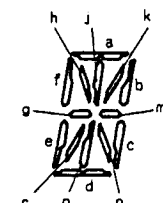

- TO X14 CN3 (1/3) F
- TO X09 CN2 (2/3) I
- TO X14 CN2 (1/3) A
- TO X09 CN1 (2/3) H
- TO X09 WH6 (2/3) K
- TO X09 WH5 (2/3) J

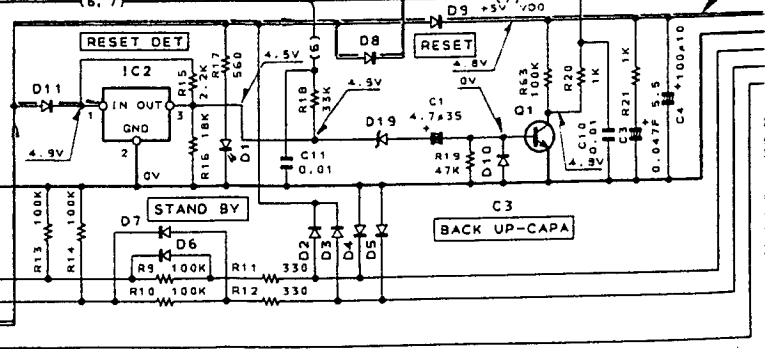
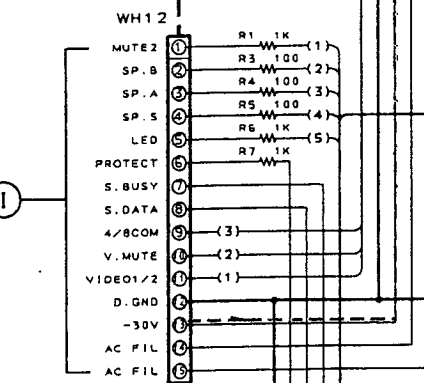
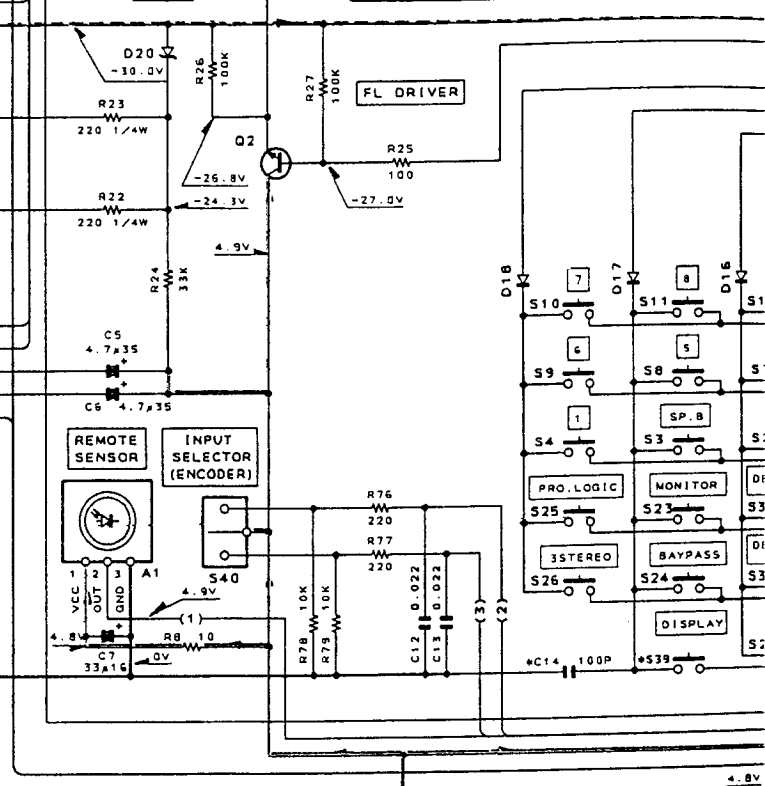
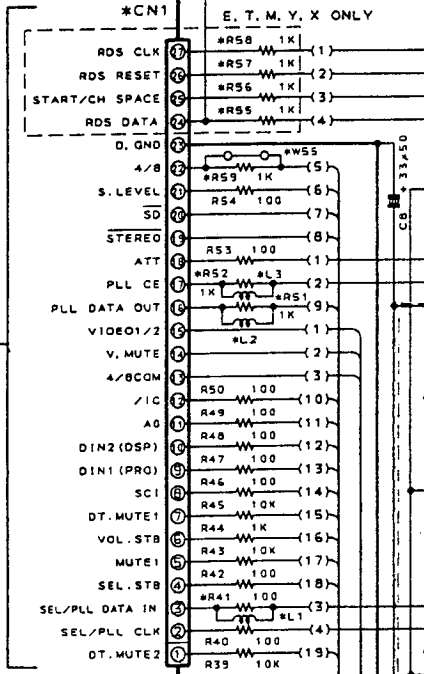

For Service Manuals Contact
MAURITRON TECHNICAL SERVICES
 8 Cherry Tree Rd, Chinnor
 Oxon OX9 4QY
 Tel: 01844-351694 Fax: 01844-352554
 Email: enquiries@mauritron.co.uk

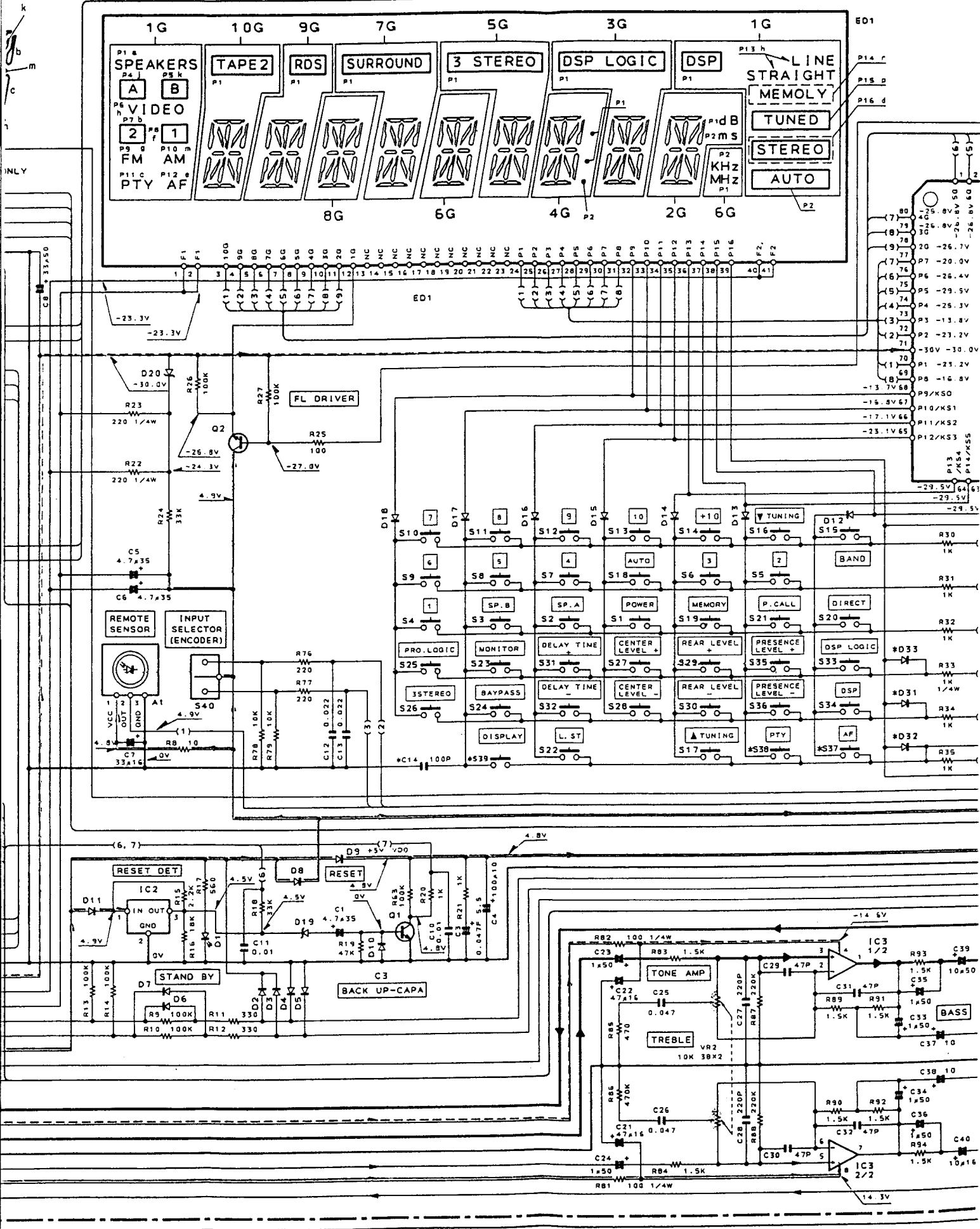

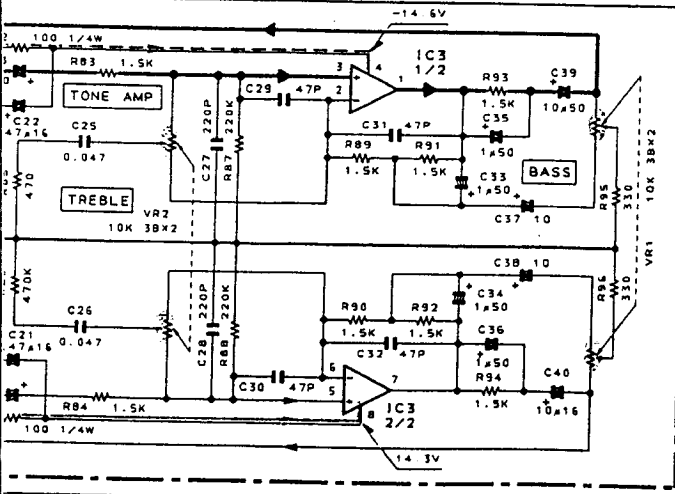
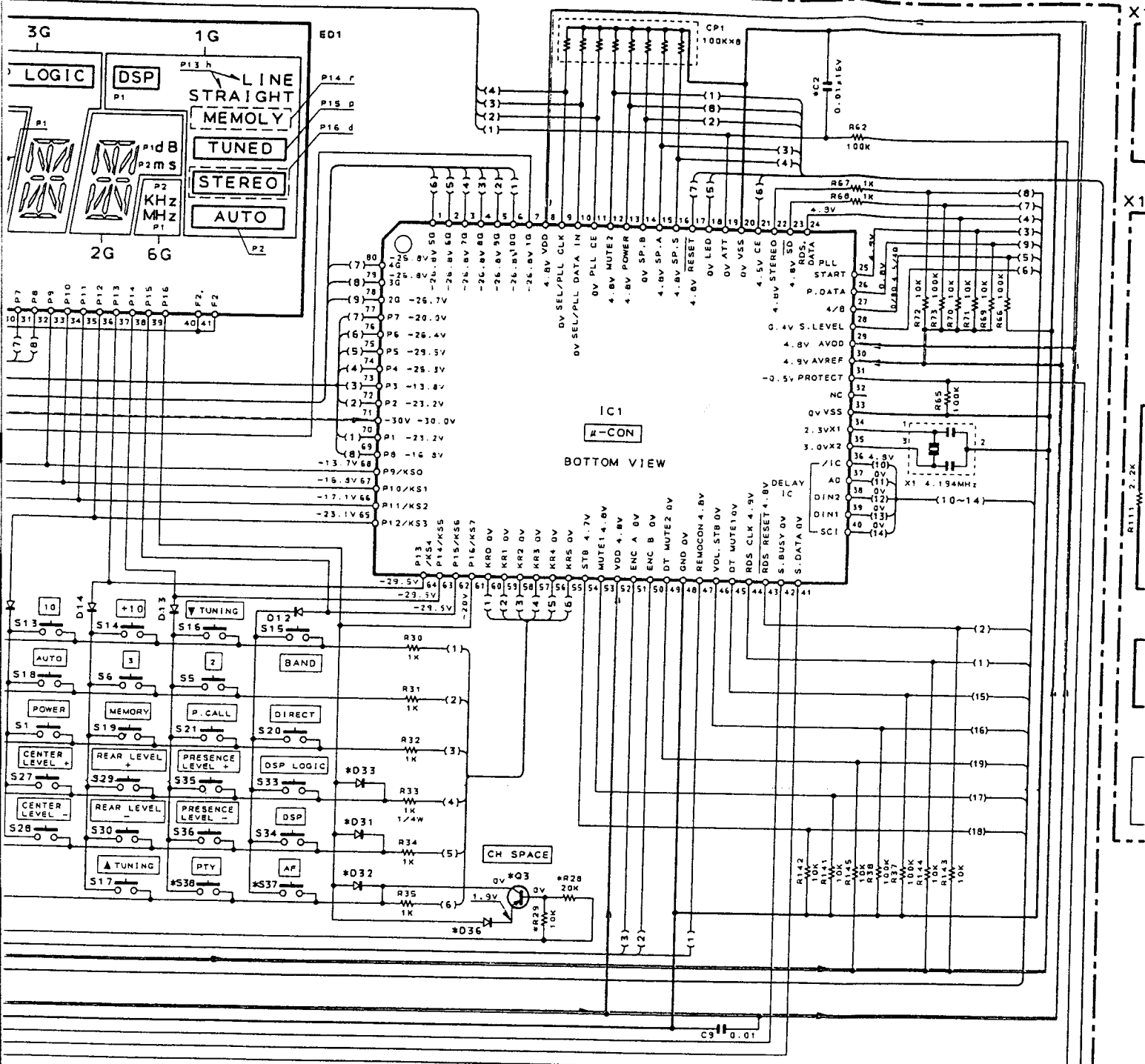

For Service Manuals Contact
MAURITRON TECHNICAL SERVICES
 8 Cherry Tree Rd, Chinnor
 Oxon OX9 4QY
 Tel: 01844-351694 Fax: 01844-352554
 Email: enquiries@mauritron.co.uk

X13 A/6

ABB	UNIT	REF NO	Q3	D31	D32	D33	D36	C2, C14	R28, 29	R41, S1, S2 R55-S8	R59	R104
K, P	0-10		NO	YES	NO	NO	NO	NO	NO	NC	YES	YES
M	0-21		YES	NO	NO	NO	YES	NO	YES	NC	YES	NO
Y	2-91		YES	NO	NO	NO	YES	NO	YES	NC	YES	NO
X	0-71		NO	NO	YES	NO	NO	NO	NO	NC	YES	NO
E	2-71		NO	NO	YES	YES	NO	YES	NO	YES	NO	NO
T	0-51		NO	NO	YES	YES	NO	YES	NO	YES	NO	NO

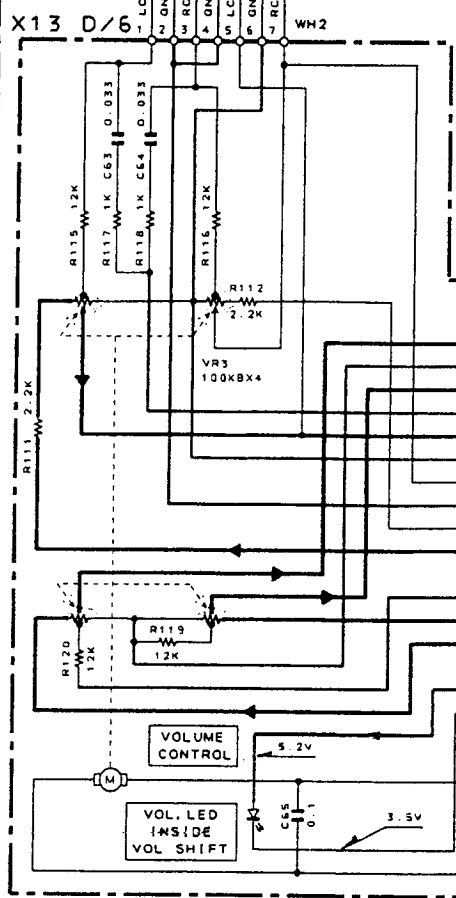
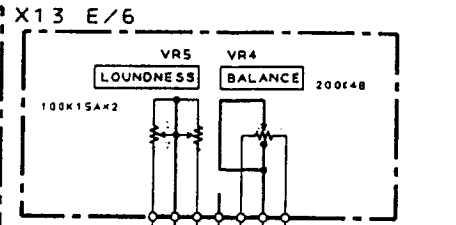
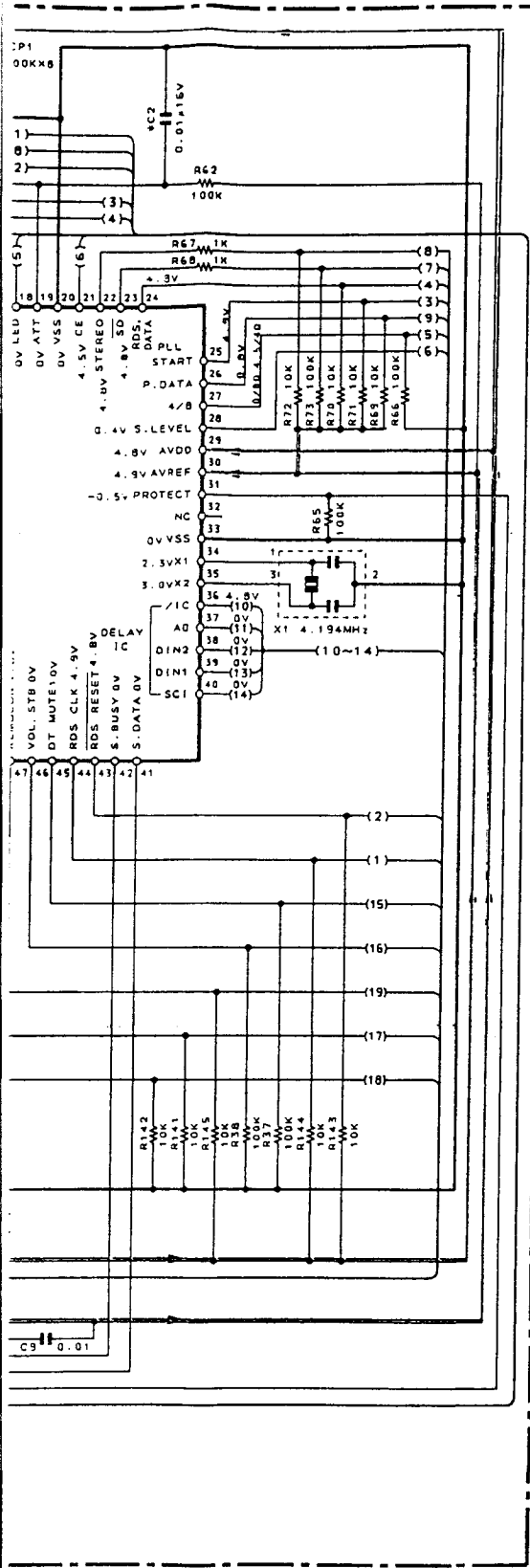

- X13-719X-XX
- IC1 : #PD78044GF-021
 - IC2 : PST529C
 - IC3 : NJM4565L
 - Q1, 2 : 2SC1740S (Q, R) or 2SC2785 (F, E)
 - Q3 : 2SA933S (Q, R) or 2SA1175 (F, E)
 - Q4 : 2SC2003 (L, K)
 - Q5 : 2SC3940A (R, S)
 - D1 : B30-1291-05
 - D2~18 : HSS104 or ISS133
 - 31-35, 44
 - D19 : HZS2.7N (B2) or RD2.7ES (B2)
 - D20 : HZS5.1N (B2) or RD5.1ES (B2)
 - D40-43 : S5688B or ISR139-100
 - D45 : HZS6.2N (B2) or RD6.2ES (B2)
 - ED1 : 10-MT-58GK
 - A1 : W02-1129-05 or W02-1046-05

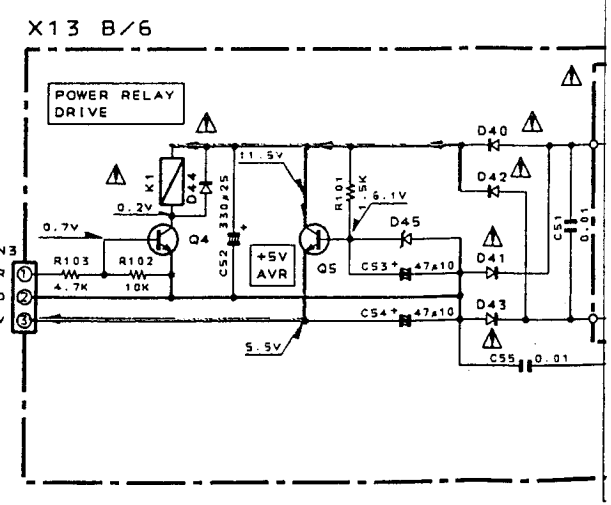

D31	D32	D33	D36	C2, C14	R28, 29	R41, 51, 52 R55-58	R59	R104	S37-39 W55	L1-3
YES	NO	NO	NO	NO	NO	NC	YES	YES	NO	YES
NO	NO	NO	YES	NO	YES	NC	YES	NO	NO	YES
NO	NO	NO	YES	NO	YES	NC	YES	NO	NO	YES
NO	YES	NO	NO	NO	NO	NC	YES	NO	NO	YES
NO	YES	YES	NO	YES	NO	YES	NO	NO	YES	NO
NO	YES	YES	NO	YES	NO	YES	NO	NO	YES	NO

X13-719X-XX

- IC1 : #PD78044GF-021
- IC2 : PST529C
- IC3 : NJM4555L

- Q1, 2 : 2SC1740S (Q, R) or 2SC2785 (F, E)
- Q3 : 2SA933S (Q, R) or 2SA1175 (F, E)
- Q4 : 2SC2003 (L, K)
- Q5 : 2SC3940A (R, S)
- D1 : B30-1291-05
- D2-18 : HSS104 or ISS133
- 31-35, 44

- D19 : HZS2.7N (B2) or RD2.7ES (B2)
- D20 : HZS5.1N (B2) or RD5.1ES (B2)
- D40-43 : S5688B or ISR139-100
- D45 : HZS6.2N (B2) or RD6.2ES (B2)
- ED1 : 10-MT-58GK
- A1 : W02-1129-05 or W02-1046-05

K, P TYPE

DESTINATION	K	P
Ref.No.	0-10	1-01
F6.7	W244	8A
	W245	250V

(X09)

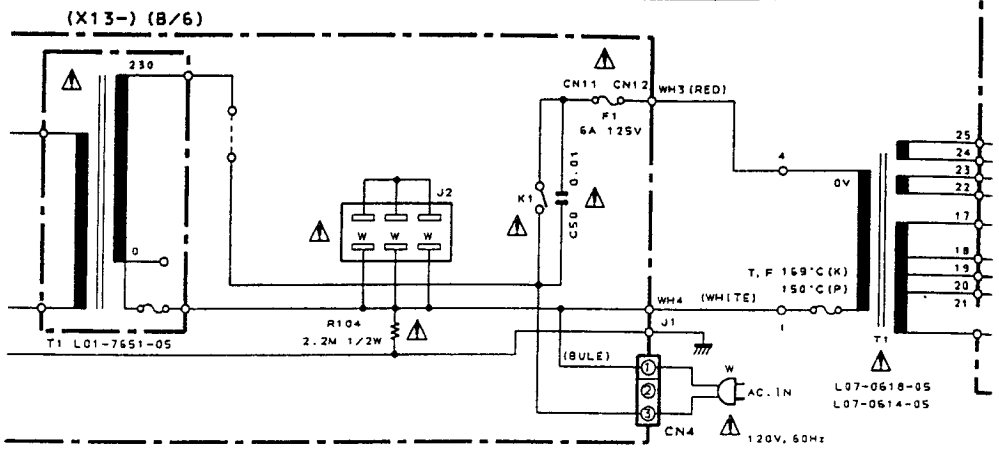

E, T, X TYPE

ABB	UNIT	REF NO	F3, CN9	J3, J4
X	0-71	NO	NO	NO
E	2-71	YES	YES	YES
T	0-51	NO	NO	YES

(X0)

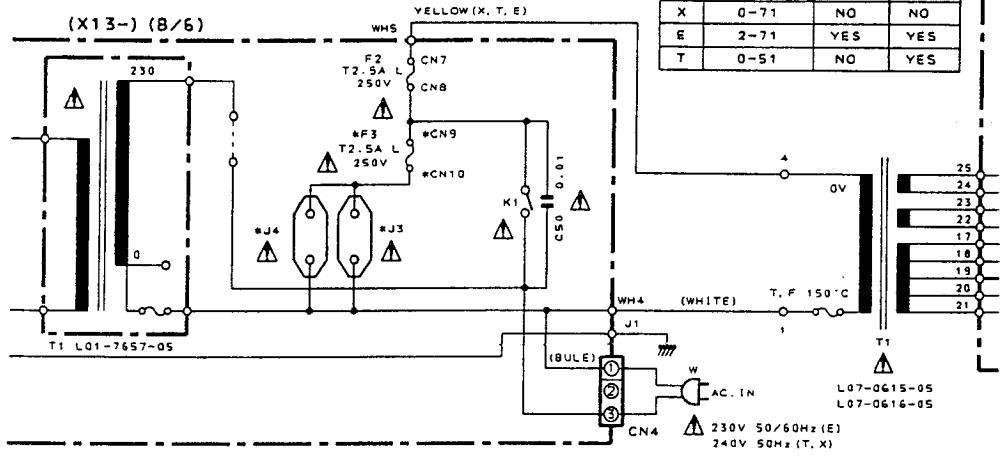

X13 C/6

ABB	UNIT	REF NO	J2	J3, 4
Y	2-91	YES	NO	NO
M	0-21	NO	NO	YES

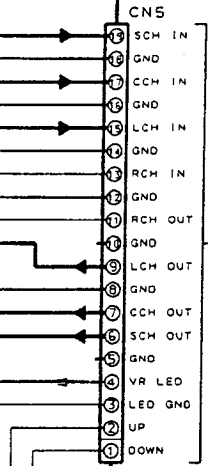
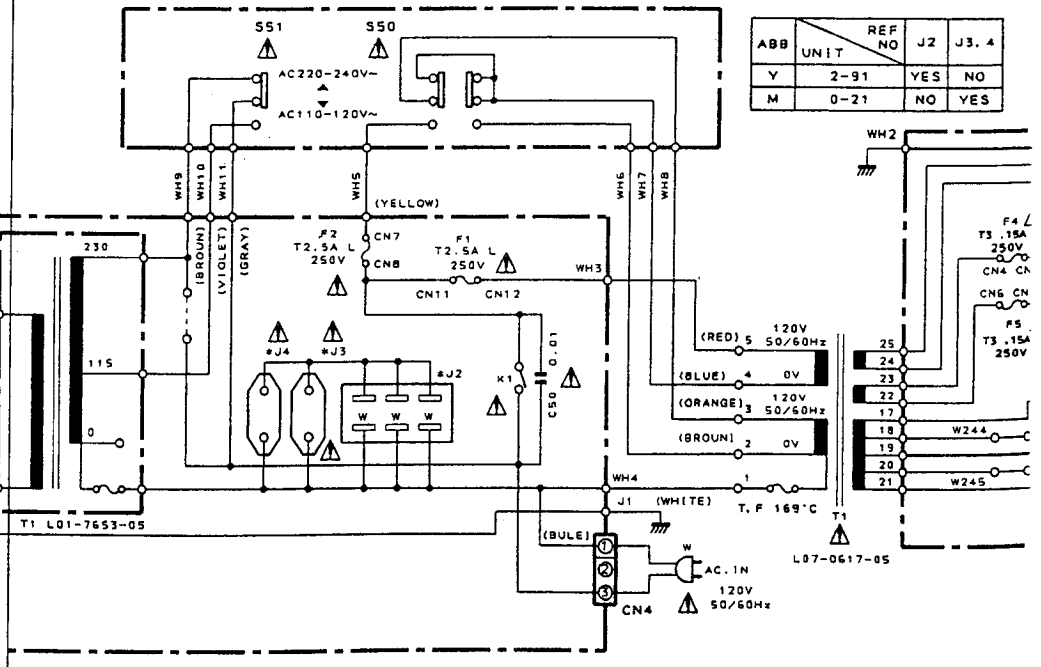

B/6

ER RELAY VE

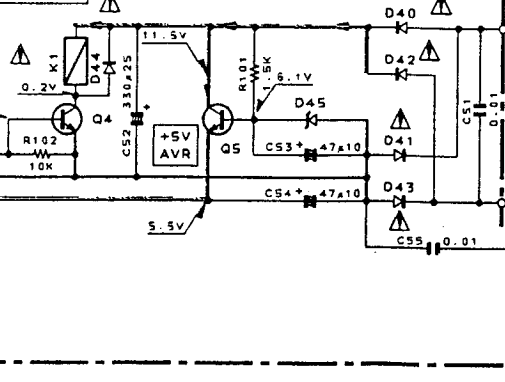

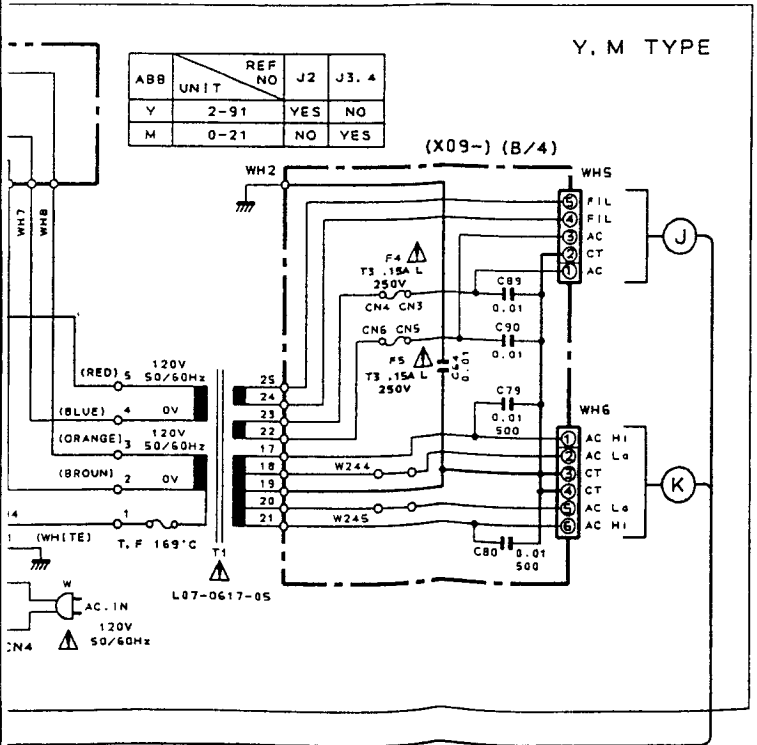
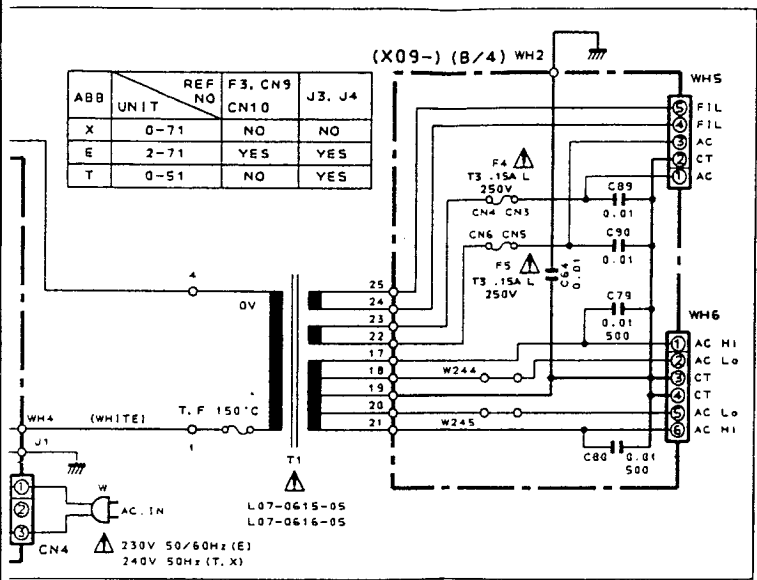
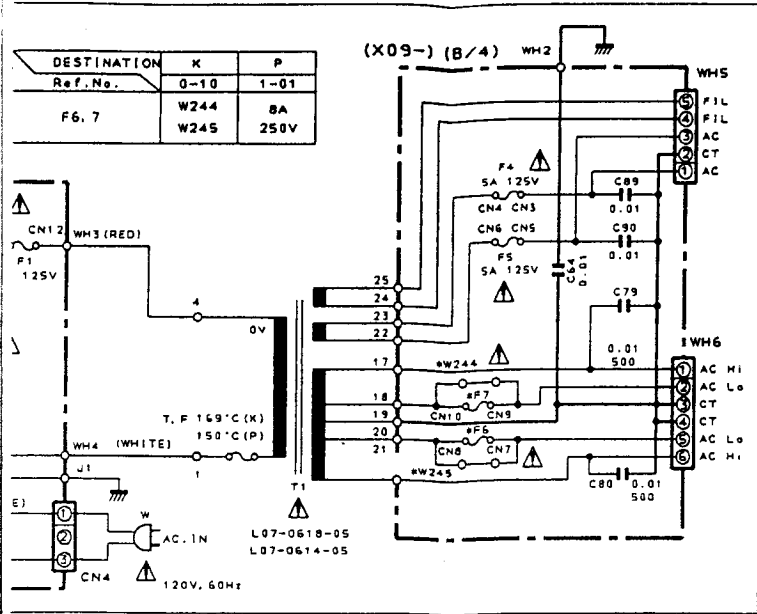

For Service Manuals Contact
MAURITRON TECHNICAL SERVICES
 8 Cherry Tree Rd, Chinnor
 Oxon OX9 4QY
 Tel: 01844-351694 Fax: 01844-352554
 Email: enquiries@mauritron.co.uk

DC voltages are as measured with a high impedance voltmeter. Values may vary slightly due to variations between individual instruments or/and units.

Les tensions c.c. doivent être mesurées avec un voltmètre à haute impédance. Les valeurs peuvent différer légèrement du fait des variations inhérentes aux appareils et aux instruments de mesure individuels.

Die angegebenen Gleichspannungswerte wurden mit einem hochohmigen Spannungsmesser gemessen. Dabei schwanken die Meßwerte aufgrund von Unterschieden zwischen einzelnen Instrumenten oder Geräten u. U. geringfügig.

CAUTION: For continued safety, replace safety critical components only with manufacturer's recommended parts (refer to parts list). indicates safety critical components. To reduce the risk of electric shock, leakage-current or resistance measurements shall be carried out (exposed parts are acceptably insulated from the supply circuit) before the appliance is returned to the customer.

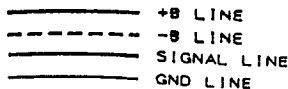

KR-V6050/7050

PARTS LIST

UNIT LIST

	Singapore made	Malaysia made
Audio unit	X09-3750-11 (K) X09-3751-02 (P) X09-3750-22 (Y, M, X, T) X09-3752-72 (E) X09-3750-11 (KWW) X09-3751-02 (PWW)	X09-3750-11 (K) X09-3751-02 (P)
Accessory unit	X13-7200-10 (K, P) X13-7202-91 (Y) X13-7200-21 (M) X13-7200-71 (X) X13-7202-71 (E) X13-7200-10 (T) X13-7200-11 (KWW) X13-7200-10 (PWW)	X13-7200-10 (K, P)
Receiver unit	X14-3680-11 (K, P) X14-3680-22 (Y, M) X14-3680-72 (X) X14-3682-72 (E) X14-3680-51 (T) X14-3680-11 (KWW, PWW)	X14-3680-11 (K, P)

For Service Manuals Contact
MAURITRON TECHNICAL SERVICES
 8 Cherry Tree Rd, Chinnor
 Oxon OX9 4QY
 Tel:- 01844-351694 Fax:- 01844-352554
 Email:- enquiries@mauritron.co.uk

KR-V6050/7050

PARTS LIST

* New Parts

Parts without Parts No. are not supplied.

Les articles non mentionnes dans le Parts No. ne sont pas fournis.

Teile ohne Parts No. werden nicht geliefert.

Ref. No. 参照番号	Address 位置	New Parts 新	Parts No. 部品番号	Description 部品名 / 規格	Desti- nation 仕向	Re- marks 備考
KR-V6050 (SINGAPORE MADE)						
601	1A	*	A01-2998-11	METALLIC CABINET		
602	2A	*	A22-1623-02	SUB PANEL ASSY	KPYMX	
602	2A	*	A22-1624-02	SUB PANEL ASSY	E	
602	2A	*	A22-1635-02	SUB PANEL ASSY	T	
603	3A	*	A60-0314-02	PANEL	KPYMXT	
603	3A	*	A60-0315-02	PANEL	E	
605	1A	*	A70-0925-05	REMOTE CONTROLLER ASSY	KPYMXT	
605	1A	*	A70-0926-05	REMOTE CONTROLLER ASSY	E	
606	1A		A09-0106-08	BATTERY COVER		
608	2A	*	B07-2243-02	ESCUTCHEON	KPYMXT	
608	2A	*	B07-2244-02	ESCUTCHEON	E	
609	2A	*	B10-1945-23	FRONT GLASS	KPYMX	
609	2A	*	B10-1947-23	FRONT GLASS	TE	
610	2A		B43-0287-04	KENWOOD BADGE	E	
-			B46-0092-23	WARRANTY CARD	K	
-			B46-0094-03	WARRANTY CARD	Y	
-			B46-0095-03	WARRANTY CARD	Y	
-			B46-0096-33	WARRANTY CARD	X	
-			B46-0121-23	WARRANTY CARD	P	
-			B46-0122-23	WARRANTY CARD	E	
-			B46-0143-13	WARRANTY CARD	T	
-			B46-0197-00	QUESTIONNAIRE CARD	K	
-			B58-0513-04	CAUTION CARD (PRESET220-240)	Y	
-		*	B60-1009-00	INSTRUCTION MANUAL (ENGLISH)	KPYMX	
-		*	B60-1010-00	INSTRUCTION MANUAL (FRENCH)	PE	
-		*	B60-1011-00	INSTRUCTION MANUAL (SPA, CHI)	M	
-		*	B60-1012-00	INSTRUCTION MANUAL (GE, DU, IT)	E	
-		*	B60-1183-00	INSTRUCTION MANUAL (ENGLISH)	E	
-		*	B60-1196-00	INSTRUCTION MANUAL (ENGLISH)	T	
△ 615	1B		E03-0115-05	AC PLUG ADAPTER	M	
△ 616	1D		E30-2592-15	AC POWER CORD	ME	
△ 616	1D		E30-2605-05	AC POWER CORD	Y	
△ 616	1D		E30-2650-05	AC POWER CORD	KP	
△ 616	1D		E30-2717-05	AC POWER CORD	X	
△ 616	1D		E30-2721-05	AC POWER CORD	T	
617	1B, 2B		E31-7966-05	FLAT CABLE X13(CN1)-X14(CN3)	KPX	
617	1B, 2B		E35-0019-05	FLAT CABLE X13(CN1)-X14(CN3)	YMTE	
618	2C	*	E35-0416-15	FLAT CABLE X09(CN1)-X13(CN5)		
619	2D		F20-1284-05	INSULATING BOARD		
620	2D		F20-1297-05	INSULATING SHEET	KPYMXT	
621	3A		G11-1098-04	SOFT TAPE		
-		*	H50-0476-04	ITEM CARTON CASE	KPYXE	
-		*	H50-0477-04	ITEM CARTON CASE	M	
-		*	H50-0661-04	ITEM CARTON CASE	T	
-		*	H10-5387-02	POLYSTYRENE FOAMED FIXTURE	KPYMXE	
-		*	H10-5388-02	POLYSTYRENE FOAMED FIXTURE	KPYMXE	
-		*	H10-5472-02	POLYSTYRENE FOAMED FIXTURE	T	
-		*	H10-5473-02	POLYSTYRENE FOAMED FIXTURE	T	
-		*	H13-0118-04	CARTON BOARD	X	
-			H25-0225-04	PROTECTION BAG (850X450X0.03)	KPYMXE	
-			H25-0232-04	PROTECTION BAG (235X350X0.03)	KPYMXE	

L:Scandinavia

K:USA

P:Canada

Y:PX(Far East, Hawaii)

T:England

E:Europe

Y:AAFES(Europe)

X:Australia

M:Other Areas

△ indicates safety critical components.

KR-V6050/7050

PARTS LIST

* New Parts

Parts without Parts No. are not supplied.

Les articles non mentionnés dans le Parts No. ne sont pas fournis.

Teile ohne Parts No. werden nicht geliefert.

Ref. No. 参照番号	Address 位置	New Parts	Parts No. 部品番号	Description 部品名 / 規格	Desti- nation 仕向	Re- marks 備考
-			H25-0651-04	PROTECTION BAG (0232 PRINTED)	T	
-			H25-0654-04	PROTECTION BAG (0225 PRINTED)	T	
622	3C, 3D		J02-1013-05	FOOT	KPYMX	
622	3C, 3D		J02-1034-05	FOOT	TE	
624	1A		J19-2815-04	ANTENNA HOLDER		
625	2D, 3D		J19-3180-05	UNIT HOLDER		
628	1D		J42-0083-05	POWER CORD BUSHING		
-			J61-0307-05	WIRE BAND		
630	3A	*	K29-5611-04	KNØB BASS, TREBLE		
631	3A	*	K29-5612-04	KNØB INPUT SELECTOR		
632	3A	*	K29-5613-04	KNØB VOLUME		
633	3A	*	K29-5672-04	KNØB LOUDNESS, BALANCE		
635	1B	*	L07-0614-05	POWER TRANSFORMER	P	
635	1B	*	L07-0615-05	POWER TRANSFORMER	E	
635	1B	*	L07-0616-05	POWER TRANSFORMER	XT	
635	1B	*	L07-0617-05	POWER TRANSFORMER	YM	
635	1B	*	L07-0618-05	POWER TRANSFORMER	K	
A	1D		N08-0128-35	BINDING POST (EARTH)	YMXT	
A	1D		N09-2909-05	TAPTITE SCREW (EARTH)	KP	
C	2D		N09-0333-05	TAPPING SCREW (3X12)		
D	2A, 3A		N09-1445-05	SET SCREW (M3X8)		
E	1A, 3C		N86-4008-45	BINDING HEAD TAPTITE SCREW		
G	1A, 1D		N89-3008-45	BINDING HEAD TAPTITE SCREW		
H	1B, 2B		N89-3008-46	BINDING HEAD TAPTITE SCREW		
640	1B		T90-0174-05	LOOP ANTENNA		
641	1A		T90-0175-05	T TYPE ANTENNA		
642	1B		T90-0185-05	ANTENNA ADAPTOR	TE	
KR-V6050 (MALAYSIA MADE)						
601	1A	*	A01-2998-11	METALLIC CABINET		
602	2A	*	A22-1623-02	SUB PANEL ASSY		
603	3A	*	A60-0314-02	PANEL		
605	1A	*	A70-0925-05	REMOTE CONTROLLER ASSY		
606	1A	*	A09-0106-08	BATTERY COVER		
608	2A	*	B07-2243-02	ESCUTCHEON		
609	2A	*	B10-1945-23	FRONT GLASS		
-			B46-0092-23	WARRANTY CARD	K	
-			B46-0121-23	WARRANTY CARD	P	
-			B46-0197-00	QUESTIONNAIRE CARD	K	
-		*	B60-1009-00	INSTRUCTION MANUAL (ENGLISH)		
-		*	B60-1010-00	INSTRUCTION MANUAL (FRENCH)	P	
616	1D		E30-2650-05	AC POWER CORD		
617	1B, 2B		E31-7966-05	FLAT CABLE X13(CN1)-X14(CN3)		
618	2C	*	E35-0416-15	FLAT CABLE X09(CN1)-X13(CN5)		
619	2D		F20-1284-05	INSULATING BOARD		
620	2D		F20-1297-05	INSULATING SHEET		
621	3A		G11-1098-04	SOFT TAPE		
-		*	H50-0662-04	ITEM CARTON CASE		
-		*	H10-5512-02	POLYSTYRENE FOAMED FIXTURE L		
-		*	H10-5513-02	POLYSTYRENE FOAMED FIXTURE R		
-			H25-0225-04	PROTECTION BAG (850X450X0.03)		
-			H25-0232-04	PROTECTION BAG (235X350X0.03)		

L:Scandinavia

K:USA

P:Canada

Y:PX(Far East, Hawaii)

T:England

E:Europe

Y:AAFES(Europe)

X:Australia

M:Other Areas

△ indicates safety critical components.

KR-V6050/7050

PARTS LIST

For Service Manuals Contact
MAURITRON TECHNICAL SERVICES
 8 Cherry Tree Rd, Chinnor
 Oxon OX9 4QY
 Tel: 01844-351694 Fax: 01844-352554
 Email: enquiries@mauritron.co.uk

* New Parts

Parts without Parts No. are not supplied.

Les articles non mentionnés dans le Parts No. ne sont pas fournis.

Teile ohne Parts No. werden nicht geliefert.

Ref. No. 参照番号	Address 位置	New Parts 新	Parts No. 部品番号	Description 部品名 / 規格	Desti- nation 仕向	Re- marks 備考
622	3C, 3D		J02-1013-05	FOOT		
624	1A		J19-2815-04	ANTENNA HOLDER		
625	2D, 3D		J19-3180-05	UNIT HOLDER		
628	1D		J42-0083-05	POWER CORD BUSHING		
-			J61-0307-05	WIRE BAND		
630	3A	*	K29-5611-04	KNØB BASS, TREBLE		
631	3A	*	K29-5612-04	KNØB INPUT SELECTØR		
632	3A	*	K29-5613-04	KNØB VOLUME		
633	3A	*	K29-5672-04	KNØB LOUDNESS, BALANCE		
635	1B	*	L07-0614-05	POWER TRANSFORMER	P	
635	1B	*	L07-0618-05	POWER TRANSFORMER	K	
A	1D		N09-2909-05	TAPTITE SCREW (EARTH)		
C	2D		N09-0333-05	TAPPING SCREW (3X12)		
D	2A, 3A		N09-1445-05	SET SCREW (M3X8)		
E	1A, 3C		N86-4008-45	BINDING HEAD TAPTITE SCREW		
G	1A, 1D		N89-3008-45	BINDING HEAD TAPTITE SCREW		
H	1B, 2B		N89-3008-46	BINDING HEAD TAPTITE SCREW		
640	1B		T90-0174-05	LOOP ANTENNA		
641	1A		T90-0175-05	T TYPE ANTENNA		
KR-V7050 (SINGAPORE MADE)						
601	1A	*	A01-2998-11	METALLIC CABINET		
602	2A	*	A22-1621-02	SUB PANEL ASSY	KPYMX	
602	2A	*	A22-1622-02	SUB PANEL ASSY	TE	
603	3A	*	A60-0312-02	PANEL		
605	1A	*	X94-1010-91	REMOTE CONTROL ASSY UNIT	KPYMX	
605	1A	*	X94-1011-11	REMOTE CONTROL ASSY UNIT	TE	
606	1A		A09-0126-03	BATTERY COVER		
608	2A	*	B07-2230-02	ESCUTCHEON		
609	2A	*	B10-1945-23	FRONT GLASS	KPYMX	
609	2A	*	B10-1947-23	FRONT GLASS	TE	
610	2A		B43-0287-04	KENWOOD BADGE		
-			B46-0092-23	WARRANTY CARD	K	
-			B46-0094-03	WARRANTY CARD	Y	
-			B46-0095-03	WARRANTY CARD	Y	
-			B46-0096-33	WARRANTY CARD	X	
-			B46-0121-23	WARRANTY CARD	P	
-			B46-0122-23	WARRANTY CARD	E	
-			B46-0143-13	WARRANTY CARD	T	
-			B46-0197-00	QUESTIONNAIRE CARD	K	
-			B58-0513-04	CAUTION CARD (PRESET220-240)	Y	
-		*	B60-1002-00	INSTRUCTION MANUAL (ENGLISH)	KPYMX	
-		*	B60-1003-00	INSTRUCTION MANUAL (FRENCH)	PE	
-		*	B60-1004-00	INSTRUCTION MANUAL (CHINESE)	M	
-		*	B60-1005-00	INSTRUCTION MANUAL (GE, DU, IT)	E	
-		*	B60-1006-00	INSTRUCTION MANUAL (SPANISH)	ME	
-		*	B60-1184-00	INSTRUCTION MANUAL (ENGLISH)	TE	
615	1B		E03-0115-05	AC PLUG ADAPTER	M	
616	1D		E30-2592-15	AC POWER CORD	ME	
616	1D		E30-2605-05	AC POWER CORD	Y	
616	1D		E30-2650-05	AC POWER CORD	KP	
616	1D		E30-2717-05	AC POWER CORD	X	
616	1D		E30-2721-05	AC POWER CORD	T	

L:Scandinavia

K:USA

P:Canada

Y:PX(Far East, Hawaii)

T:England

E:Europe

Y:AAFES(Europe)

X:Australia

M:Other Areas

 indicates safety critical components.

KR-V6050/7050

PARTS LIST

x New Parts

Parts without Parts No. are not supplied.

Les articles non mentionnés dans le Parts No. ne sont pas fournis.

Teile ohne Parts No. werden nicht geliefert.

Ref. No. 参照番号	Address 位置	New Parts 新	Parts No. 部品番号	Description 部品名 / 規格	Desti- nation 仕向	Re- marks 備考
617	1B, 2B		E31-7966-05	FLAY CABLE X13(CN1)-X14(CN3)	KPX	
617	1B, 2B		E35-0019-05	FLAT CABLE X13(CN1)-X14(CN3)	YMTE	
618	2C	*	E35-0416-15	FLAT CABLE X09(CN1)-X13(CN5)		
619	2D		F20-1284-05	INSULATING BOARD		
620	2D		F20-1297-05	INSULATING SHEET		
621	3A		G11-1098-04	SOFT TAPE		
		*	H50-0474-04	ITEM CARTON CASE	KPYXE	
		*	H50-0475-04	ITEM CARTON CASE	M	
		*	H50-0490-04	ITEM CARTON CASE	T	
		*	H10-5387-02	POLYSTYRENE FOAMED FIXTURE	KPYMXE	
		*	H10-5388-02	POLYSTYRENE FOAMED FIXTURE	KPYMXE	
		*	H10-5472-02	POLYSTYRENE FOAMED FIXTURE	T	
		*	H10-5473-02	POLYSTYRENE FOAMED FIXTURE	T	
		*	H13-0118-04	CARTON BOARD	X	
			H25-0225-04	PROTECTION BAG (850X450X0.03)	KPYMXE	
			H25-0232-04	PROTECTION BAG (235X350X0.03)	KPYMXE	
			H25-0651-04	PROTECTION BAG (0232 PRINTED)	T	
			H25-0654-04	PROTECTION BAG (0225 PRINTED)	T	
622	3C, 3D		J02-1013-05	FOOT REAR	KP	
622	3C, 3D		J02-1024-05	FOOT FRONT	KP	
622	3C, 3D		J02-1034-05	FOOT	YMXTE	
624	1A		J19-2815-04	ANTENNA HOLDER		
625	2D, 3D		J19-3180-05	UNIT HOLDER		
626	2B		J19-3323-05	UNIT HOLDER		
628	1D		J42-0083-05	POWER CORD BUSHING		
			J61-0307-05	WIRE BAND		
630	3A	*	K29-5611-04	KNOB BASS, TREBLE		
631	3A	*	K29-5612-04	KNOB INPUT SELECTOR		
632	3A	*	K29-5613-04	KNOB VOLUME		
633	3A	*	K29-5672-04	KNOB LOUDNESS, BALANCE		
635	1B	*	L07-0614-05	POWER TRANSFORMER	P	
635	1B	*	L07-0615-05	POWER TRANSFORMER	E	
635	1B	*	L07-0616-05	POWER TRANSFORMER	XT	
635	1B	*	L07-0617-05	POWER TRANSFORMER	YM	
635	1B	*	L07-0618-05	POWER TRANSFORMER	K	
A	1D		N08-0128-35	BINDING POST (EARTH)	YMXTE	
A	1D		N09-2909-05	TAPTITE SCREW (EARTH)	KP	
C	2D		N09-0333-05	TAPPING SCREW (3X12)		
D	2A, 3A		N09-1445-05	SET SCREW (M3X8)		
E	1A, 3C		N86-4008-45	BINDING HEAD TAPTITE SCREW		
G	1A, 1D		N89-3008-45	BINDING HEAD TAPTITE SCREW		
H	1B, 2B		N89-3008-46	BINDING HEAD TAPTITE SCREW		
640	1B		T90-0174-05	LOOP ANTENNA		
641	1A		T90-0175-05	T TYPE ANTENNA		
642	1B		T90-0185-05	ANTENNA ADAPTOR	TE	
KR-V7050 (MALAYSIA MADE)						
601	1A	*	A01-2998-11	METALLIC CABINET		
602	2A	*	A22-1621-02	SUB PANEL ASSY		
603	3A	*	A60-0312-02	PANEL		
605	1A	*	X94-1010-91	REMOTE CONTROL ASSY UNIT		
606	1A		A09-0126-03	BATTERY COVER		

For Service Manuals Contact
MAURITRON TECHNICAL SERVICES
 8 Cherry Tree Rd, Chinnor
 Oxon OX9 4QY
 Tel: 01844-351694 Fax: 01844-352554
 Email: enquiries@mauritron.co.uk

L:Scandinavia

K:USA

P:Canada

Y:PX(Far East, Hawaii)

T:England

E:Europe

Y:AAFES(Europe)

X:Australia

M:Other Areas

⚠ indicates safety critical components.

KR-V6050/7050

PARTS LIST

* New Parts

Parts without Parts No. are not supplied.

Les articles non mentionnés dans le Parts No. ne sont pas fournis.

Teile ohne Parts No. werden nicht geliefert.

Ref. No. 参照番号	Address 位置	New Parts 新	Parts No. 部品番号	Description 部品名 / 規格	Desti- nation 仕 向	Re- marks 備考
608	2A	*	807-2230-02	ESCUTCHEON		
609	2A	*	810-1945-23	FRONT GLASS		
610	2A		843-0287-04	KENWOOD BADGE		
-			846-0092-23	WARRANTY CARD	K	
-			846-0121-23	WARRANTY CARD	P	
-			846-0197-00	QUESTIONNAIRE CARD	K	
-		*	860-1002-00	INSTRUCTION MANUAL (ENGLISH)		
-		*	860-1003-00	INSTRUCTION MANUAL (FRENCH)	P	
△ 616	1D		E30-2650-05	AC POWER CORD		
617	1B, 2B		E31-7966-05	FLAT CABLE X13(CN1)-X14(CN3)		
618	2C	*	E35-0416-15	FLAT CABLE X09(CN1)-X13(CN5)		
619	2D		F20-1284-05	INSULATING BOARD		
620	2D		F20-1297-05	INSULATING SHEET		
621	3A		G11-1098-04	SOFT TAPE		
-		*	H50-0663-04	ITEM CARTON CASE		
-		*	H10-5512-02	POLYSTYRENE FOAMED FIXTURE L		
-		*	H10-5513-02	POLYSTYRENE FOAMED FIXTURE R		
-			H25-0225-04	PROTECTION BAG (850X450X0.03)		
-			H25-0232-04	PROTECTION BAG (235X350X0.03)		
622	3C, 3D		J02-1013-05	FOOT REAR		
622	3C, 3D		J02-1024-05	FOOT FRONT		
624	1A		J19-2815-04	ANTENNA HOLDER		
625	2D, 3D		J19-3180-05	UNIT HOLDER		
626	2B		J19-3323-05	UNIT HOLDER		
△ 628	1D		J42-0083-05	POWER CORD BUSHING		
-			J61-0307-05	WIRE BAND		
630	3A	*	K29-5611-04	KNOB BASS, TREBLE		
631	3A	*	K29-5612-04	KNOB INPUT SELECTOR		
632	3A	*	K29-5613-04	KNOB VOLUME		
633	3A	*	K29-5672-04	KNOB LOUDNESS, BALANCE		
△ 635	1B	*	L07-0614-05	POWER TRANSFORMER	P	
△ 635	1B	*	L07-0618-05	POWER TRANSFORMER	K	
A	1D		N09-2909-05	TAPTITE SCREW (EARTH)		
C	2D		N09-0333-05	TAPPING SCREW (3X12)		
D	2A, 3A		N09-1445-05	SET SCREW (M3X8)		
E	1A, 3C		N86-4008-45	BINDING HEAD TAPTITE SCREW		
G	1A, 1D		N89-3008-45	BINDING HEAD TAPTITE SCREW		
H	1B, 2B		N89-3008-46	BINDING HEAD TAPTITE SCREW		
640	1B		T90-0174-05	LOOP ANTENNA		
641	1A		T90-0175-05	T TYPE ANTENNA		
AUDIO UNIT (X09-375X-XX)						
C1 ,2			CE04LW1H010M	ELECTRO 1.0UF 50WV		
C3 -8			CC45FSL1H101J	CERAMIC 100PF J		
C9 ,10			CE04LW0J221M	ELECTRO 220UF 6.3WV		
C11 ,12			CC45FSL1H100D	CERAMIC 10PF D		
C13 ,14			CE04LW2A010M	ELECTRO 1.0UF 100WV		
C15 ,16			CC45FSL1H221J	CERAMIC 220PF J		
C17 ,18			CC45FSL1H020C	CERAMIC 2.0PF C		
C19 ,20			CC45FSL1H470J	CERAMIC 47PF J		
C21 -24			CK45FF1H103Z	CERAMIC 0.010UF Z		
C25 -28			CF92FV1H224J	MF 0.22UF J	E	6

L:Scandinavia

K:USA

P:Canada

Y:PX(Far East, Hawaii)

T:England

E:Europe

6 : KR-V6050

Y:AAFES(Europe)

X:Australia

M:Other Areas

7 : KR-V7050

△ indicates safety critical components.

KR-V6050/7050

PARTS LIST

× New Parts

Parts without Parts No. are not supplied.

Les articles non mentionnés dans le Parts No. ne sont pas fournis.

Teile ohne Parts No. werden nicht geliefert.

Ref. No. 参照番号	Address 位置	New Parts 新	Parts No. 部品番号	Description 部品名 / 規格	Desti- nation 仕 向	Re- marks 備考
C25 -28			CF92FV1H224J	MF 0.22UF J	TE	7
C25 ,26			CQ92FM1H104J	MYLAR 0.10UF J	KPYMX	7
C25 ,26			CQ92FM1H104J	MYLAR 0.10UF J	KPYMXT	6
C29			CC45FSL1H101J	CERAMIC 100PF J		7
C30			CE04LW0J221M	ELECTRØ 220UF 6.3WV		
C31 ,32			CE04LW1H010M	ELECTRØ 1.0UF 50WV		7
C31 ,32			CE04LW1H010M	ELECTRØ 1.0UF 50WV	KPYMXT	6
C33 -38			CC45FSL1H101J	CERAMIC 100PF J		7
C33 -38			CC45FSL1H101J	CERAMIC 100PF J	KPYMXT	6
C39 ,40			CE04LW1A470M	ELECTRØ 47UF 10WV		7
C39 ,40			CE04LW1A470M	ELECTRØ 47UF 10WV	KPYMXT	6
C41 ,42			CC45FSL1H680J	CERAMIC 68PF J		7
C41 ,42			CC45FSL1H680J	CERAMIC 68PF J	KPYMXT	6
C43 ,44			CK45FF1H103Z	CERAMIC 0.010UF Z		
C45 ,46			CC45FSL1H221J	CERAMIC 220PF J		7
C45 ,46			CC45FSL1H221J	CERAMIC 220PF J	KPYMXT	6
C47 ,48			CC45FSL1H020C	CERAMIC 2.0PF C		7
C47 ,48			CC45FSL1H020C	CERAMIC 2.0PF C	KPYMXT	6
C49			CC45FSL1H680J	CERAMIC 68PF J		7
C49			CC45FSL1H680J	CERAMIC 68PF J	KPYMXT	6
C50			CC45FSL1H151J	CERAMIC 150PF J		7
C50			CC45FSL1H151J	CERAMIC 150PF J	KPYMXT	6
C51 -54			CK45FF1H103Z	CERAMIC 0.010UF Z		7
C51 -54			CK45FF1H103Z	CERAMIC 0.010UF Z	KPYMXT	6
C55 -58			CF92FV1H224J	MF 0.22UF J	TE	7
C55 ,56			CQ92FM1H104J	MYLAR 0.10UF J	KPYMXT	6
C59			CE04LW2A100M	ELECTRØ 10UF 100WV		
C60			CE04LW2A470M	ELECTRØ 47UF 100WV		
C61 ,62			CE04LW1V470M	ELECTRØ 47UF 35WV		7
C61 ,62			CE04LW1V470M	ELECTRØ 47UF 35WV	KPYMXT	6
C63			CE04LW1H010M	ELECTRØ 1.0UF 50WV		
C64			CK45FF1H103Z	CERAMIC 0.010UF Z		
C65			CE04LW1H4R7M	ELECTRØ 4.7UF 50WV		
C66			CE04LW1H2R2M	ELECTRØ 2.2UF 50WV		
C67 ,68			CE04LW1A101M	ELECTRØ 100UF 10WV		6
C69			CE04LW1C101M	ELECTRØ 100UF 16WV		
C70			CE04LW1C470M	ELECTRØ 47UF 16WV		
C71			CE04LW1C101M	ELECTRØ 100UF 16WV		
C72			CE04LW1A470M	ELECTRØ 47UF 10WV		
C73			CE04LW1C220M	ELECTRØ 22UF 16WV		
C74			CE04LW2A2R2M	ELECTRØ 2.2UF 100WV		6
C75			CE04LW1V4R7M	ELECTRØ 4.7UF 35WV		6
C76			CE04LW1V220M	ELECTRØ 22UF 35WV		
C77 ,78			CE04LW1V100M	ELECTRØ 10UF 35WV		
C79 ,80			CK45FE2H103P	CERAMIC 0.010UF P		
C81 ,82		*	C90-3490-05	ELECTRØ 6800UF 71WV		
C83 ,84			CE04LW1V222M	ELECTRØ 2200UF 35WV		
C85 ,86			CK45FF1H103Z	CERAMIC 0.010UF Z		7
C87 -90			CK45FF1H103Z	CERAMIC 0.010UF Z		
C89 ,90			CK45FF1H103Z	CERAMIC 0.010UF Z		6
C91			CE04LW1J470M	ELECTRØ 47UF 63WV		
C92			CE04LW1V101M	ELECTRØ 100UF 35WV		
C93 -96			CK45FF1H472Z	CERAMIC 4700PF Z	E	6
C93 -96			CK45FF1H472Z	CERAMIC 4700PF Z	TE	7
C97 ,98			CK45FB1H102K	CERAMIC 1000PF K		

L:Scandinavia

K:USA

P:Canada

Y:PX(Far East, Hawaii)

T:England

E:Europe

6 : KR-V6050

Y:AAFES(Europe)

X:Australia

M:Other Areas

7 : KR-V7050

⚠ indicates safety critical components.

KR-V6050/7050

For Service Manuals Contact
MAURITRON TECHNICAL SERVICES
 8 Cherry Tree Rd, Chinnor
 Oxon OX9 4QY
 Tel: 01844-351694 Fax: 01844-352554
 Email: enquiries@mauritron.co.uk

PARTS LIST

x New Parts

Parts without Parts No. are not supplied.

Les articles non mentionnés dans le Parts No. ne sont pas fournis.

Teile ohne Parts No. werden nicht geliefert.

Ref. No. 参照番号	Address 位置	New Parts 新	Parts No. 部品番号	Description 部品名 / 規格	Desti- nation 仕向	Re- marks 備考
C99			CK45FF1H472Z	CERAMIC 4700PF Z	TE	7
C100			CK45FF1H103Z	CERAMIC 0.010UF Z	TE	7
C101, 102			CK45FB1H102K	CERAMIC 1000PF K		7
C101, 102			CK45FB1H102K	CERAMIC 1000PF K	KPYMXT	6
C103, 104			CC45FSL1H561J	CERAMIC 560PF J	E	6
C103, 104			CC45FSL1H561J	CERAMIC 560PF J	TE	7
C105, 106			CK45FF1H103Z	CERAMIC 0.010UF Z		
C107-110			CC45FSL1H101J	CERAMIC 100PF J	E	6
C107-110			CC45FSL1H101J	CERAMIC 100PF J	TE	7
C111, 112			CE04LW1A470M	ELECTRO 47UF 10WV		
C114			CK45FF1H103Z	CERAMIC 0.010UF Z		
C115, 116			CE04LW0J221M	ELECTRO 220UF 6.3WV		
C117			CK45FF1H223Z	CERAMIC 0.022UF Z		6
C118			C91-0749-05	CERAMIC 220PF K		6
C119, 120			CK45FF1H103Z	CERAMIC 0.010UF Z		
CN1	2C		E40-4159-05	FLAT CABLE CONNECTOR		
J1			E70-0020-05	LOCK TERMINAL BOARD SPEAKERS	KPYMX	7
J1			E70-0020-05	LOCK TERMINAL BOARD SPEAKERS	KPYMXT	6
J1			E70-0029-05	SCREW TERMINAL BOARD SPEAKERS	E	6
J1			E70-0029-05	SCREW TERMINAL BOARD SPEAKERS	TE	7
J2			E70-0014-05	LOCK TERMINAL BOARD CEN, REA SP		7
J2			E70-0014-05	LOCK TERMINAL BOARD CEN, REA SP	KPYMXT	6
J3		*	E63-0069-05	PHONE JACK MONI, VIDEO 1,2		
J4			E11-0188-05	MINIATURE PHONE JACK SYNCHRO		
J5			E11-0207-05	PHONE JACK HEAD PHONES	KPYMXT	6
J5			E11-0208-05	PHONE JACK HEAD PHONES	E	6
J5			E11-0208-05	PHONE JACK HEAD PHONES		7
F4 ,5			F04-5022-05	FUSE (UL) (125V 5A UL)	KP	
F4 ,5			F05-3121-05	FUSE (SEMCO) (250V T3.15A)	YMXTE	
F6 ,7			F05-8029-05	FUSE (UL) (250V 8A)	P	
CN3 -6			J13-0075-05	FUSE CLIP		
CN7 -10			J13-0041-05	FUSE CLIP	P	
J8			J11-0098-05	WIRE CLAMPER		6
L1 -3			L39-0085-05	PHASE COMPENSATION COIL	KPYMX	7
L1 -3			L39-0085-05	PHASE COMPENSATION COIL	KPYMXT	6
L1 -4			L39-0085-05	PHASE COMPENSATION COIL	TE	7
L1 ,2			L39-0085-05	PHASE COMPENSATION COIL	E	6
CP1 -3			R90-0840-05	COMPOSITE ELEMENTS		7
CP1 -3			R90-0840-05	COMPOSITE ELEMENTS	KPYMXT	6
CP1 ,2			R90-0840-05	COMPOSITE ELEMENTS	E	6
R15 ,16			RD14NB2E221J	RD 220 J 1/4W		
R21 ,22			RD14NB2E121J	RD 120 J 1/4W		
R23 ,24			RD14NB2E221J	RD 220 J 1/4W		
R31 -34			RD14NB2E220J	RD 22 J 1/4W		
R37 ,38			RD14NB2E332J	RD 3.3K J 1/4W		
R41 ,42			RS14KB3D4R7J	FL-PROOF RS 4.7 J 2W		
R56			RD14NB2E4R7J	RD 4.7 J 1/4W		
R75 ,76			RD14NB2E221J	RD 220 J 1/4W		7
R75 ,76			RD14NB2E221J	RD 220 J 1/4W	KPYMXT	6
R81 ,82			RD14NB2E121J	RD 120 J 1/4W		7
R81 ,82			RD14NB2E121J	RD 120 J 1/4W	KPYMXT	6
R83 ,84			RD14NB2E221J	RD 220 J 1/4W		7
R83 ,84			RD14NB2E221J	RD 220 J 1/4W	KPYMXT	6

L:Scandinavia

K:USA

P:Canada

Y:PX(Far East, Hawaii)

T:England

E:Europe

6 : KR-V6050

Y:AAFES(Europe)

X:Australia

M:Other Areas

7 : KR-V7050

△ indicates safety critical components.

KR-V6050/7050

PARTS LIST

× New Parts

Parts without Parts No. are not supplied.

Les articles non mentionnes dans le Parts No. ne sont pas fournis.

Teile ohne Parts No. werden nicht geliefert.

Ref. No. 参照番号	Address 位置	New Parts 新	Parts No. 部品番号	Description 部品名 / 規格	Desti- nation 仕向	Re- marks 備考
R91 -94			RD14NB2E220J	RD 22 J 1/4W		7
R91 -94			RD14NB2E220J	RD 22 J 1/4W	KPYMXT	6
R97			RD14NB2E392J	RD 3.9K J 1/4W		7
R97			RD14NB2E392J	RD 3.9K J 1/4W	KPYMXT	6
R98			RD14NB2E822J	RD 8.2K J 1/4W		7
R98			RD14NB2E822J	RD 8.2K J 1/4W	KPYMXT	6
R101,102			RS14KB3D4R7J	FL-PROOF RS 4.7 J 2W		7
R101,102			RS14KB3D4R7J	FL-PROOF RS 4.7 J 2W	KPYMXT	6
R118			RD14NB2E101J	RD 100 J 1/4W		
R120			RD14NB2E4R7J	RD 4.7 J 1/4W		6
R142			RD14NB2E680J	RD 68 J 1/4W		
R152			R92-0203-05	METAL-PLATE 0.47 K 5W		7
R152			R92-0203-05	METAL-PLATE 0.47 K 5W	KPYMXT	6
R158			RD14NB2E101J	RD 100 J 1/4W		
R161			RD14NB2E470J	RD 47 J 1/4W		
R162			RD14NB2E101J	RD 100 J 1/4W		
R163			RD14NB2E470J	RD 47 J 1/4W		7
R163			RD14NB2E470J	RD 47 J 1/4W	KPYMXT	6
R164			RD14NB2E101J	RD 100 J 1/4W		7
R164			RD14NB2E101J	RD 100 J 1/4W	KPYMXT	6
R165,166			RS14KB3A561J	FL-PROOF RS 560 J 1W		
R167			RS14KB3A121J	FL-PROOF RS 120 J 1W		7
R168-170			RS14KB3A221J	FL-PROOF RS 220 J 1W		7
R168-170			RS14KB3A221J	FL-PROOF RS 220 J 1W	KPYMXT	6
R169,170			RS14KB3A221J	FL-PROOF RS 220 J 1W	E	6
R171,172			RS14KB3A391J	FL-PROOF RS 390 J 1W		
R176			RS14KB3D4R7J	FL-PROOF RS 4.7 J 2W		
R186			RD14NB2E222J	RD 2.2K J 1/4W		
VR1 -3			R12-1617-05	TRIMMING POT.(2.2K) IDL ADJ		7
VR1 ,2			R12-1618-05	TRIMMING POT.(3.3K) IDL ADJ		6
VR3			R12-1617-05	TRIMMING POT.(2.2K) IDL ADJ	KPYMXT	6
K1 ,2			S51-2078-05	MAGNETIC RELAY		
K1 ,2			S51-2092-05	MAGNETIC RELAY		
K3			S76-0005-05	MAGNETIC RELAY		7
K3			S76-0005-05	MAGNETIC RELAY	KPYMXT	6
K4			S76-0016-05	MAGNETIC RELAY		7
K4			S76-0017-05	MAGNETIC RELAY		7
S1			S31-2136-05	SLIDE SWITCH IMPEDANCE SELECT		6
D1 ,2			HSS104A	DIODE		
D1 ,2			1SS131	DIODE		
D3 ,4			HZS11N(B2)	ZENER DIODE		7
D3 ,4			RD11ES(B2)	ZENER DIODE		7
D5 ,6			HZS13N(B2)	ZENER DIODE		7
D5 ,6			RD13ES(B2)	ZENER DIODE		7
D7 -18			HSS104A	DIODE		7
D7 -18			1SS131	DIODE		7
D9 -18			HSS104A	DIODE	KPYMXT	6
D9 -18			1SS131	DIODE	KPYMXT	6
D9 ,10			HSS104A	DIODE	E	6
D9 ,10			1SS131	DIODE	E	6
D15 -18			HSS104A	DIODE	E	6
D15 -18			1SS131	DIODE	E	6
D19			HZS5.1N(B2)	ZENER DIODE		

L:Scandinavia

K:USA

P:Canada

Y:PX(Far East, Hawaii)

T:England

E:Europe

6 : KR-V6050

Y:AAFES(Europe)

X:Australia

M:Other Areas

7 : KR-V7050

⚠ indicates safety critical components.

KR-V6050/7050

PARTS LIST

* New Parts

Parts without Parts No. are not supplied.

Les articles non mentionnes dans le Parts No. ne sont pas fournis.

Teile ohne Parts No. werden nicht geliefert.

Ref. No. 参照番号	Address 位置	New Parts 新	Parts No. 部品番号	Description 部品名 / 規格	Desti- nation 仕 向	Re- marks 備考
D19			RD5.1ES(B2)	ZENER DIODE		
D20 -22			HSS104A	DIODE	E	6
D20 -22			1SS131	DIODE	E	6
D20 -23			HSS104A	DIODE	KPYMXT	6
D20 -23			1SS131	DIODE	KPYMXT	6
D20 -24			HSS104A	DIODE		7
D20 -24			1SS131	DIODE		7
D25			HZS5.1N(B2)	ZENER DIODE		6
D25			RD5.1ES(B2)	ZENER DIODE		6
D26			HSS104A	DIODE		
D26			1SS131	DIODE		
D27			HZS4.7N(B2)	ZENER DIODE		
D27			RD4.7ES(B2)	ZENER DIODE		
D28			D3SBA20F03	DIODE		
D28			RBV-402LFA	DIODE		
D29			D5SBA20F03	DIODE		6
D29			RBV-602LFA	DIODE		6
D29 ,30			D5SBA20F03	DIODE		7
D29 ,30			RBV-602LFA	DIODE		7
D31 ,32			S5688B	DIODE		
D31 ,32			1SR139-100	DIODE		
D33			HZS15N(B2)	ZENER DIODE		
D33			RD15ES(B2)	ZENER DIODE		
D34			HZS16N(B2)	ZENER DIODE		
D34			RD16ES(B2)	ZENER DIODE		
D35 ,36			HSS104A	DIODE		
D35 ,36			1SS131	DIODE		
D37 ,38			HZS5.1N(B2)	ZENER DIODE		
D37 ,38			RD5.1ES(B2)	ZENER DIODE		
D39 -42			HSS104	DIODE	E	6
D39 -42			1SS133	DIODE	E	6
D39 -52			HSS104	DIODE		7
D39 -52			HSS104	DIODE	KPYMXT	6
D39 -52			1SS133	DIODE		7
D39 -52			1SS133	DIODE	KPYMXT	6
D45 -52			HSS104	DIODE	E	6
D45 -52			1SS133	DIODE	E	6
D53 ,54			HZS11N(B2)	ZENER DIODE		7
D53 ,54			RD11ES(B2)	ZENER DIODE		7
D55 ,56			HZS13N(B2)	ZENER DIODE		7
D55 ,56			RD13ES(B2)	ZENER DIODE		7
D57 -61			HSS104A	DIODE		7
D57 -61			1SS131	DIODE		7
D59 -63			HSS104A	DIODE		6
D59 -63			1SS131	DIODE		6
IC1			TA8409S	IC(MOTOR CONTROL)		
IC2		*	CXA1558L	IC		
Q1 -4			2SA992(F,E)	TRANSISTOR		
Q5 -8			2SC2631(R,S)	TRANSISTOR		
Q9 ,10			2SA1123(R,S)	TRANSISTOR		
Q11 ,12			2SC4137F19(V,W)	TRANSISTOR		
Q13 ,14			2SD2222BT	TRANSISTOR		
Q13 ,14		*	2SD2449LB	TRANSISTOR		
Q15 ,16			2SB1470BT	TRANSISTOR		
Q15 ,16		*	2SB1594LB	TRANSISTOR		

L:Scandinavia

K:USA

P:Canada

Y:PX(Far East, Hawaii)

T:England

E:Europe

6 : KR-V6050

Y:AAFES(Europe)

X:Australia

M:Other Areas

7 : KR-V7050

△ indicates safety critical components

KR-V6050/7050

PARTS LIST

* New Parts

Parts without Parts No. are not supplied.

Les articles non mentionnés dans le Parts No. ne sont pas fournis.

Teile ohne Parts No. werden nicht geliefert.

Ref. No. 参照番号	Address 位置	New Parts 新	Parts No. 部品番号	Description 部品名 / 規格	Desti- nation 仕 向	Re- marks 備考	
Q17 ,18			2SC1845(F, E)	TRANSISTOR	For Service Manuals Contact MAURITRON TECHNICAL SERVICES 8 Cherry Tree Rd, Chinnor Oxon OX9 4QY Tel:- 01844-351694 Fax:- 01844-352554 Email:- enquiries@mauritron.co.uk	7	
Q19 ,20			2SA992(F, E)	TRANSISTOR		7	
Q21			2SA1175(F, E)	TRANSISTOR		7	
Q21			2SA933S(Q, R)	TRANSISTOR		7	
Q22			2SC1740S(Q, R)	TRANSISTOR		7	
Q22			2SC2785(F, E)	TRANSISTOR		7	
Q23 ,24			2SC1845(F, E)	TRANSISTOR		7	
Q31 -34			2SA992(F, E)	TRANSISTOR		KPYMXT	6
Q31 -34			2SA992(F, E)	TRANSISTOR		KPYMXT	6
Q35			2SC2631(R, S)	TRANSISTOR		KPYMXT	7
Q35			2SC2631(R, S)	TRANSISTOR	KPYMXT	6	
Q36			2SC1845(F, E)	TRANSISTOR	KPYMXT	7	
Q36			2SC1845(F, E)	TRANSISTOR	KPYMXT	6	
Q37			2SC2631(R, S)	TRANSISTOR	KPYMXT	7	
Q37			2SC2631(R, S)	TRANSISTOR	KPYMXT	6	
Q38			2SC1845(F, E)	TRANSISTOR	KPYMXT	7	
Q38			2SC1845(F, E)	TRANSISTOR	KPYMXT	6	
Q39			2SA1123(R, S)	TRANSISTOR	KPYMXT	7	
Q39			2SA1123(R, S)	TRANSISTOR	KPYMXT	6	
Q40			2SA992(F, E)	TRANSISTOR	KPYMXT	7	
Q40			2SA992(F, E)	TRANSISTOR	KPYMXT	6	
Q41 ,42			2SC4137F19(V, W)	TRANSISTOR	KPYMXT	7	
Q41 ,42			2SC4137F19(V, W)	TRANSISTOR	KPYMXT	6	
Q43			2SD2255BT	TRANSISTOR	K		
Q43			2SD2255BT*1	TRANSISTOR	K		
Q43		*	2SD2384LB	TRANSISTOR	PYMXT	6	
Q43		*	2SD2384LB	TRANSISTOR	PYMXT	7	
Q44			2SD2340BT	TRANSISTOR	KPYMXT	6	
Q44			2SD2340BT	TRANSISTOR	KPYMXT	7	
Q45			2SB1493BT	TRANSISTOR	K		
Q45			2SB1493BT*1	TRANSISTOR	K		
Q45		*	2SB1555LB	TRANSISTOR	PYMXT	6	
Q45		*	2SB1555LB	TRANSISTOR	PYMXT	7	
Q46			2SB1531BT	TRANSISTOR	KPYMXT	6	
Q46			2SB1531BT	TRANSISTOR	KPYMXT	7	
Q47 -50			2SC1845(F, E)	TRANSISTOR	KPYMXT	7	
Q47 -50			2SC1845(F, E)	TRANSISTOR	KPYMXT	6	
Q49 ,50			2SC1845(F, E)	TRANSISTOR	E	6	
Q51			2SA992(F, E)	TRANSISTOR			
Q52			2SC1845(F, E)	TRANSISTOR			
Q53			2SC1740S(Q, R)	TRANSISTOR			
Q53			2SC2785(F, E)	TRANSISTOR			
Q55			2SA992(F, E)	TRANSISTOR		6	
Q56 -58			2SC1740S(Q, R)	TRANSISTOR	KPYMXT	6	
Q56 -58			2SC2785(F, E)	TRANSISTOR	KPYMXT	6	
Q56 -61			2SC1740S(Q, R)	TRANSISTOR		7	
Q56 -61			2SC2785(F, E)	TRANSISTOR		7	
Q56 ,57			2SC1740S(Q, R)	TRANSISTOR	E	6	
Q56 ,57			2SC2785(F, E)	TRANSISTOR	E	6	
Q60 ,61			2SC1740S(Q, R)	TRANSISTOR		6	
Q60 ,61			2SC2785(F, E)	TRANSISTOR		6	
Q62			DTC124ES	DIGITAL TRANSISTOR			
Q62			UN4212	DIGITAL TRANSISTOR			
Q63			2SA1175(F, E)	TRANSISTOR			
Q63			2SA933S(Q, R)	TRANSISTOR			

L:Scandinavia

K:USA

P:Canada

Y:PX(Far East, Hawaii)

T:England

E:Europe

6 : KR-V6050

Y:AAFES(Europe)

X:Australia

M:Other Areas

7 : KR-V7050

 indicates safety critical components.

KR-V6050/7050

PARTS LIST

× New Parts

Parts without Parts No. are not supplied.

Les articles non mentionnes dans le Parts No. ne sont pas fournis.

Teile ohne Parts No. werden nicht geliefert.

Ref. No. 参照番号	Address 位置	New Parts 新	Parts No. 部品番号	Description 部品名 / 規格	Desti- nation 仕 向	Re- marks 備考
Q64 -67 Q64 -67 Q65 ,66 Q68			2SC2878(B) 2SC2878(B) 2SC2878(B) 2SA1534A	TRANSISTOR TRANSISTOR TRANSISTOR TRANSISTOR	KPYMXT E	7 6 6
ACCESSORY UNIT (X13-719X-XX) : KR-V7050						
D1			B30-1291-05	LED(LN21CPSLX(V)-(TA4))		
C1			CE04LW1V4R7M	ELECTRO 4.7UF 35WV	TE	
C2			C91-0769-05	CERAMIC 0.01UF K		
C3			C90-1827-05	BACKUP 0.047F 5.5WV		
C4			CE04LW1A101M	ELECTRO 100UF 10WV		
C5 ,6			CE04LW1V4R7M	ELECTRO 4.7UF 35WV		
C7			CE04LW1C330M	ELECTRO 33UF 16WV	TE	
C8			CE04LW1H330M	ELECTRO 33UF 50WV		
C9 -11			C91-0769-05	CERAMIC 0.01UF K		
C12 ,13			CF92FV1H223J	MF 0.022UF J	TE	
C14			C91-0745-05	CERAMIC 100PF K		
C21 ,22			CE04LW1C470M	ELECTRO 47UF 16WV		
C23 ,24			CE04LW1H010M	ELECTRO 1.0UF 50WV		
C25 ,26			CF92FV1H473J	MF 0.047UF J		
C27 ,28			CC45FSL1H221J	CERAMIC 220PF J		
C29 -32			CC45FSL1H470J	CERAMIC 47PF J		
C33 ,34			C90-3253-05	ELECTRO 1UF 50WV	TE	
C35			CE04LW1H010M	ELECTRO 1.0UF 50WV		
C36			C90-3253-05	ELECTRO 1UF 50WV		
C37 -39			CE04LW1H100M	ELECTRO 10UF 50WV		
C40			C90-3225-05	ELECTRO 10UF 16WV		
△ C50			C91-1439-05	FILM 0.01UF 250VAC		
C51			CK45FF1H103Z	CERAMIC 0.010UF Z		
C52			CE04EW1E331M	ELECTRO 330UF 25WV		
C53 ,54			CE04LW1A470M	ELECTRO 47UF 10WV		
C55			CK45FF1H103Z	CERAMIC 0.010UF Z		
C63 ,64			CF92FV1H333J	MF 0.033UF J	TE	
C65			CF92FV1H104J	MF 0.10UF J		
C201			CF92FV1H271K	MF 270PF K	TE	
C202			CE04LW1V100M	ELECTRO 10UF 35WV	TE	
C203,204			CK45FF1H103Z	CERAMIC 0.010UF Z	TE	
C205			CE04LW1V100M	ELECTRO 10UF 35WV	TE	
C206,207			CC45FCH1H270J	CERAMIC 27PF J	TE	
C208			CE04LW1V100M	ELECTRO 10UF 35WV	TE	
C209-211			CK45FF1H103Z	CERAMIC 0.010UF Z	TE	
CN1	2B		E40-4203-05	FLAT CABLE CONNECTOR	KPX	
CN1	2B		E40-4207-05	FLAT CABLE CONNECTOR	YMTE	
CN5	2C		E40-4199-05	FLAT CABLE CONNECTOR		
J2			E03-0111-05	AC OUTLET	KPY	
J3 ,4			E03-0108-05	AC OUTLET	ME	
△ J3 ,4			E03-0109-05	AC OUTLET	T	
△ F1			F05-6029-05	FUSE (UL) (125V 6A)	KP	
△ F1 ,2			F05-2525-05	FUSE (SEMKO) (250V T2.5A)	YM	
△ F2			F05-2525-05	FUSE (SEMKO) (250V T2.5A)	XT	
△ F2 ,3			F05-2525-05	FUSE (SEMKO) (250V T2.5A)	E	
CN7 -10			J13-0075-05	FUSE CLIP	E	
CN7 ,8			J13-0075-05	FUSE CLIP	YMXT	
CN11,12			J13-0075-05	FUSE CLIP	KPYM	

L:Scandinavia

K:USA

P:Canada

Y:PX(Far East, Hawaii)

T:England

E:Europe

6 : KR-V6050

Y:AAFES(Europe)

X:Australia

M:Other Areas

7 : KR-V7050

△ indicates safety critical components.

KR-V6050/7050

PARTS LIST

× New Parts

Parts without Parts No. are not supplied.

Les articles non mentionnés dans le Parts No. ne sont pas fournis.

Teile ohne Parts No. werden nicht geliefert.

Ref. No. 参照番号	Address 位置	New Parts 新	Parts No. 部品番号	Description 部品名 / 規格	Desti- nation 仕 向	Re- marks 備考
L1 -3 L201,202 T1 T1 T1			L40-1091-17	SMALL FIXED INDUCTOR(10UH,K)	KPYMX	
			L40-1001-17	SMALL FIXED INDUCTOR(10UH,K)	TE	
			L01-7651-05	POWER TRANSFORMER	KP	
			L01-7653-05	POWER TRANSFORMER	YM	
			L01-7657-05	POWER TRANSFORMER	XTE	
X1 X201 X202			L78-0267-05	RESONATOR 4.194MHz		
			L77-2002-05	CRYSTAL RESONATOR 4.332MHz	TE	
			L78-0503-05	RESONATOR 4.00MHz	TE	
CP1 R81 ,82 R104 VR1 ,2 VR3			R90-0492-05	MULTI-COMP 100KX8 J 1/6W		
			RD14NB2E101J	RD 100 J 1/4W		
			R92-0173-05	RC 2.2M M 1/2W	KP	
		*	R10-3048-05	POTENTIOMETER(10KX2) BASS,TREB		
		*	R29-5075-05	POTENTIOMETER(100KX4)VOLUME		
VR4 VR5		*	R05-5053-05	POTENTIOMETER(200K) BALANCE		
		*	R10-5063-05	POTENTIOMETER(100KX2)LOUDNESS		
K1 S1 -36 S1 -39 S50 ,51			S76-0002-05	MAGNETIC RELAY		
			S40-1064-05	PUSH SWITCH KEY BOARD	KPYMX	
			S40-1064-05	PUSH SWITCH KEY BOARD	TE	
			S62-0001-05	SLIDE SWITCH VOLTAGE SELECTOR	YM	
			T99-0509-05	SPEED DETECTOR INPUT SELECTOR		
D2 -18 D2 -18 D19 D19 D20			HSS104	DIODE		
			1SS133	DIODE		
			HZS2.7N(B2)	ZENER DIODE		
			RD2.7ES(B2)	ZENER DIODE		
			HZS5.1N(B2)	ZENER DIODE		
D20 D31 D31 D32 D32 ,33			RD5.1ES(B2)	ZENER DIODE		
			HSS104	DIODE	KP	
			1SS133	DIODE	KP	
			HSS104	DIODE	X	
			HSS104	DIODE	TE	
D36 D40 -43 D40 -43 D44 D44			HSS104	DIODE		
			S56888	DIODE	YM	
			1SR139-100	DIODE		
			HSS104	DIODE		
			1SS133	DIODE		
D45 D45 ED1 IC1 IC2			HZS6.2N(B2)	ZENER DIODE		
			RD6.2ES(B2)	ZENER DIODE		
		*	10-MT-58GK	INDICATOR TUBE		
		*	UPD78044GF-021	IC(8BIT MICROPROCESSOR)		
			PST529C	IC(SYSTEM RESET)		
IC3 IC201 IC202 Q1 ,2 Q1 ,2			NJM4565L	IC(OP AMP X2)		
			TDA7330A	IC(RDS DEMODULATOR)	TE	
			LC6543H-4600	IC	TE	
			2SC1740S(Q,R)	TRANSISTOR		
			2SC2785(F,E)	TRANSISTOR		
Q3 Q4 Q5			2SA1175(F,E)	TRANSISTOR	YM	
			2SC2003(L,K)	TRANSISTOR		
			2SC3940A(R,S)	TRANSISTOR		
A1 A1			W02-1046-05	ELECTRIC CIRCUIT MODULE		
			W02-1153-05	ELECTRIC CIRCUIT MODULE		
ACCESSORY UNIT (X13-720X-XX) KR-V6050						
D1			B30-1291-05	LED(LN21CPSLX(V)-(TA4))		

For Service Manuals Contact
MAURITRON TECHNICAL SERVICES
 3 Cherry Tree Rd, Chinnor
 Oxon OX9 4QY
 Tel: 01844-351694 Fax: 01844-352554
 Email: enquiries@mauritron.co.uk

L:Scandinavia K:USA P:Canada
 Y:PX(Far East, Hawaii) T:England E:Europe
 Y:AAFES(Europe) X:Australia M:Other Areas

△ indicates safety critical components.

KR-V6050/7050

PARTS LIST

* New Parts

Parts without Parts No. are not supplied.

Les articles non mentionnes dans le Parts No. ne sont pas fournis.

Teile ohne Parts No. werden nicht geliefert.

Ref. No. 参照番号	Address 位置	New Parts 新	Parts No. 部品番号	Description 部品名 / 規格	Desti- nation 仕向	Re- marks 備考
C1			CE04LW1V4R7M	ELECTRO 4.7UF 35WV		
C2			C91-0769-05	CERAMIC 0.01UF K	TE	
C3			C90-1827-05	BACKUP 0.047F 5.5WV		
C4			CE04LW1A101M	ELECTRO 100UF 10WV		
C5 ,6			CE04LW1V4R7M	ELECTRO 4.7UF 35WV		
C7			CE04LW1C330M	ELECTRO 33UF 16WV		
C8			CE04LW1H330M	ELECTRO 33UF 50WV		
C9 -11			C91-0769-05	CERAMIC 0.01UF K		
C12 ,13			CF92FV1H223J	MF 0.022UF J		
C14			C91-0745-05	CERAMIC 100PF K	TE	
C21 ,22			CE04LW1C470M	ELECTRO 47UF 16WV		
C23 ,24			CE04LW1H010M	ELECTRO 1.0UF 50WV		
C25 ,26			CF92FV1H473J	MF 0.047UF J		
C27 ,28			CC45FSL1H221J	CERAMIC 220PF J		
C29 -32			CC45FSL1H470J	CERAMIC 47PF J		
C33 ,34			C90-3253-05	ELECTRO 1UF 50WV		
C35			CE04LW1H010M	ELECTRO 1.0UF 50WV		
C36			C90-3253-05	ELECTRO 1UF 50WV		
C37 -39			CE04LW1H100M	ELECTRO 10UF 50WV		
C40			C90-3225-05	ELECTRO 10UF 16WV		
△ C50			C91-1439-05	FILM 0.01UF 250VAC		
C51			CK45FF1H103Z	CERAMIC 0.010UF Z		
C52			CE04EW1E331M	ELECTRO 330UF 25WV		
C53 ,54			CE04LW1A470M	ELECTRO 47UF 10WV		
C55			CK45FF1H103Z	CERAMIC 0.010UF Z		
C63 ,64			CF92FV1H333J	MF 0.033UF J		
C65			CF92FV1H104J	MF 0.10UF J		
C201			CF92FV1H271K	MF 270PF K	TE	
C202			CE04LW1V100M	ELECTRO 10UF 35WV	TE	
C203, 204			CK45FF1H103Z	CERAMIC 0.010UF Z	TE	
C205			CE04LW1V100M	ELECTRO 10UF 35WV	TE	
C206, 207			CC45FCH1H270J	CERAMIC 27PF J	TE	
C208			CE04LW1V100M	ELECTRO 10UF 35WV	TE	
C209-211			CK45FF1H103Z	CERAMIC 0.010UF Z	TE	
CN1	2B		E40-4203-05	FLAT CABLE CONNECTOR	KPX	
CN1	2B		E40-4207-05	FLAT CABLE CONNECTOR	YMTE	
CN5	2C		E40-4199-05	FLAT CABLE CONNECTOR		
J2			E03-0111-05	AC OUTLET	KPY	
J3 ,4			E03-0108-05	AC OUTLET	ME	
J3 ,4			E03-0109-05	AC OUTLET	T	
F1			F05-6029-05	FUSE (UL) (125V 6A)	KP	
F1 ,2			F05-2525-05	FUSE (SEMΚ0) (250V T2.5A)	YM	
F2			F05-2525-05	FUSE (SEMΚ0) (250V T2.5A)	XT	
F2 ,3			F05-2525-05	FUSE (SEMΚ0) (250V T2.5A)	E	
CN7 -10			J13-0075-05	FUSE CLIP	E	
CN7 ,8			J13-0075-05	FUSE CLIP	YMXT	
CN11, 12			J13-0075-05	FUSE CLIP	KPYM	
L1 -3			L40-1091-17	SMALL FIXED INDUCTOR	KPYMX	
L201, 202			L40-1001-17	SMALL FIXED INDUCTOR(10UH,K)	TE	
T1			L01-7651-05	POWER TRANSFORMER	KP	
T1			L01-7653-05	POWER TRANSFORMER	YM	
T1			L01-7657-05	POWER TRANSFORMER	XTE	
X1			L78-0267-05	RESONATOR 4.194MHZ		

L:Scandinavia

K:USA

P:Canada

Y:PX(Far East, Hawaii)

T:England

E:Europe

Y:AAFES(Europe)

X:Australia

M:Other Areas

△ indicates safety critical components.

KR-V6050/7050

PARTS LIST

× New Parts

Parts without Parts No. are not supplied.

Les articles non mentionnés dans le Parts No. ne sont pas fournis.

Teile ohne Parts No. werden nicht geliefert.

Ref. No. 参照番号	Address 位置	New Parts 新	Parts No. 部品番号	Description 部品名 / 規格	Desti- nation 仕 向	Re- marks 備考
X201 X202			L77-2002-05 L78-0503-05	CRYSTAL RESONATOR 4.332MHz RESONATOR 4.00MHz	TE TE	
CP1 R81 ,82 R104 VR1 ,2 VR3		*	R90-0492-05 RD14NB2E101J R92-0173-05 R10-3048-05 R29-5075-05	MULTI-COMP 100KX8 J 1/6W RD 100 J 1/4W RC 2.2M M 1/2W POTENTIOMETER(10KX2) BASS,TREB POTENTIOMETER(100KX4) VOLUME	KP	
VR4 VR5		*	R05-5053-05 R10-5063-05	POTENTIOMETER(200K) BALANCE POTENTIOMETER(100KX2) LOUNDNES		
△ K1 S1 -23 S1 -32 S37 -39 △ S50 ,51			S76-0002-05 S40-1064-05 S40-1064-05 S40-1064-05 S62-0001-05	MAGNETIC RELAY PUSH SWITCH KEY BOARD PUSH SWITCH KEY BOARD PUSH SWITCH KEY BOARD SLIDE SWITCH VOLTAGE SELECTOR	E KPYMXT TE YM	
S40			T99-0509-05	SPEED DETECTOR INPUT SELECTOR		
D2 -18 D2 -18 D19 D19 D20			HSS104 1SS133 HZS2.7N(B2) RD2.7ES(B2) HZS5.1N(B2)	DIODE DIODE ZENER DIODE ZENER DIODE ZENER DIODE		
D20 D31 D31 D32 D32			RD5.1ES(B2) HSS104 1SS133 HSS104 1SS133	ZENER DIODE DIODE DIODE DIODE DIODE		For Service Manuals Contact MAURITRON TECHNICAL SERVICES 8 Cherry Tree Rd, Chinnor Oxon OX9 4QY Tel:- 01844-351894 Fax:- 01844-352554 Email:- enquiries@mauritron.co.uk
D32 -34 D32 -34 D32 ,33 D32 ,33 D34			HSS104 1SS133 HSS104 1SS133 HSS104	DIODE DIODE DIODE DIODE DIODE	T T E E KPYMX	
D34 D35 D35 D36 D36			1SS133 HSS104 1SS133 HSS104 1SS133	DIODE DIODE DIODE DIODE DIODE	KPYMX E E YM YM	
D40 -43 D40 -43 D44 D44 D45			S5688B 1SR139-100 HSS104 1SS133 HZS6.2N(B2)	DIODE DIODE DIODE DIODE ZENER DIODE		
D45 ED1 IC1 IC2 IC3		*	RD6.2ES(B2) 10-MT-58GK UPD78044GF-021 PST529C NJM4565L	ZENER DIODE INDICATOR TUBE IC(8BIT MICROPROCESSOR) IC(SYSTEM RESET) IC(OP AMP X2)		
IC201 IC202 Q1 ,2 Q1 ,2 Q3			TDA7330A LC6543H-4600 2SC1740S(Q,R) 2SC2785(F,E) 2SA1175(F,E)	IC(RDS DEMODULATOR) IC TRANSISTOR TRANSISTOR TRANSISTOR	TE TE YM YM	
Q3 Q4 Q5			2SA933S(Q,R) 2SC2003(L,K) 2SC3940A(R,S)	TRANSISTOR TRANSISTOR TRANSISTOR	YM	

L:Scandinavia

K:USA

P:Canada

Y:PX(Far East, Hawaii)

T:England

E:Europe

Y:AAFES(Europe)

X:Australia

M:Other Areas

△ indicates safety critical components.

KR-V6050/7050

PARTS LIST

× New Parts

Parts without Parts No. are not supplied.

Les articles non mentionnés dans le Parts No. ne sont pas fournis.

Teile ohne Parts No. werden nicht geliefert.

Ref. No. 参照番号	Address 位置	New Parts 新	Parts No. 部品番号	Description 部品名 / 規格	Desti- nation 仕向	Re- marks 備考
A1			W02-1046-05	ELECTRIC CIRCUIT MODULE		
A1			W02-1153-05	ELECTRIC CIRCUIT MODULE		
RECEIVER UNIT (X14-368X-XX)						
C1	-4		CK45FF1H103Z	CERAMIC	0.010UF Z	
C5			CE04LW1C470M	ELECTRO	47UF 16WV	
C6			CK45FF1H103Z	CERAMIC	0.010UF Z	
C7			CE04LW1H010M	ELECTRO	1.0UF 50WV	
C8			CE04LW1HR47M	ELECTRO	0.47UF 50WV	
C9			CC45FSL1H101J	CERAMIC	100PF J	
C10			CE04LW1H2R2M	ELECTRO	2.2UF 50WV	
C11			CE04LW1H3R3M	ELECTRO	3.3UF 50WV	
C12			CK45FF1H103Z	CERAMIC	0.010UF Z	
C13			CQ92FM1H153J	MYLAR	0.015UF J	
C14	,15		CK45FF1H223Z	CERAMIC	0.022UF Z	
C16			CE04LW1V4R7M	ELECTRO	4.7UF 35WV	
C17			CK45FF1H223Z	CERAMIC	0.022UF Z	
C18			CE04LW1V100M	ELECTRO	10UF 35WV	
C19			CK45FF1H103Z	CERAMIC	0.010UF Z	
C20			CE04LW1V4R7M	ELECTRO	4.7UF 35WV	
C21			CE04LW1C101M	ELECTRO	100UF 16WV	
C27	,28		CQ92FM1H153J	MYLAR	0.015UF J	YMX
C27	,28		CQ92FM1H183J	MYLAR	0.018UF J	KP
C27	,28		CQ92FM1H392J	MYLAR	3900PF J	TE
C29	,30		CE04LW1H2R2M	ELECTRO	2.2UF 50WV	
C40			CK45FF1H103Z	CERAMIC	0.010UF Z	
C41			CC45FCH1H220J	CERAMIC	22PF J	
C42			CC45FCH1H270J	CERAMIC	27PF J	
C43	-45		CK45FB1H471K	CERAMIC	470PF K	
C46	,47		CK45FF1H103Z	CERAMIC	0.010UF Z	
C48			CQ92FM1H223J	MYLAR	0.022UF J	
C49			CE04LW1H010M	ELECTRO	1.0UF 50WV	
C50			CE04LW1C470M	ELECTRO	47UF 16WV	
C51			CE04LW1H010M	ELECTRO	1.0UF 50WV	
C52			CE04LW1A470M	ELECTRO	47UF 10WV	
C56			CC45FCH1H220J	CERAMIC	22PF J	
C62	-64		CE04LW1H010M	ELECTRO	1.0UF 50WV	
C65			CE04LW1HR22M	ELECTRO	0.22UF 50WV	
C66			CE04LW1V100M	ELECTRO	10UF 35WV	
C67	,68		CC45FSL1H101J	CERAMIC	100PF J	KPYMX
C67	,68		CC45FSL1H221J	CERAMIC	220PF J	TE
C69			CE04LW1V100M	ELECTRO	10UF 35WV	
C70			CK45FB1H561K	CERAMIC	560PF K	
C71			CQ92FM1H103J	MYLAR	0.010UF J	
C83			CK45FB1H471K	CERAMIC	470PF K	
C84	,85		C91-0745-05	CERAMIC	100PF K	
C106			CE04LW1C470M	ELECTRO	47UF 16WV	
C107			CK45FF1H473Z	CERAMIC	0.047UF Z	
C123			CE04LW1HOR1M	ELECTRO	0.1UF 50WV	TE
C135,136			CQ92FM1H682J	MYLAR	6800PF J	YM
C172			CC45FSL1H330J	CERAMIC	33PF J	TE
C173,174			CK45FB1H102K	CERAMIC	1000PF K	TE
C176			CK45FB1H102K	CERAMIC	1000PF K	KPYMX
C177			CE04LW1A470M	ELECTRO	47UF 10WV	TE
C178			CK45FF1H103Z	CERAMIC	0.010UF Z	TE

L:Scandinavia

K:USA

P:Canada

Y:PX(Far East, Hawaii)

T:England

E:Europe

6 : KR-V6050

Y:AAFES(Europe)

X:Australia

M:Other Areas

7 : KR-V7050

△ indicates safety critical components.

KR-V6050/7050

PARTS LIST

× New Parts

Parts without Parts No. are not supplied.

Les articles non mentionnes dans le Parts No. ne sont pas fournis.

Teile ohne Parts No. werden nicht geliefert.

Ref. No. 参照番号	Address 位置	New Parts 新	Parts No. 部品番号	Description 部品名 / 規格	Desti- nation 仕向	Re- marks 備考
C179, 180			CE04LW1V100M	ELECTRØ 10UF 35WV		
C181			CK45FF1H103Z	CERAMIC 0.010UF Z		
C182			CC45FSL1H150J	CERAMIC 15PF J		
C201, 202			CC45FSL1H390J	CERAMIC 39PF J	E	6
C201, 202			CC45FSL1H390J	CERAMIC 39PF J	TE	7
C203, 204			CE04LW1V100M	ELECTRØ 10UF 35WV		
C205, 206			CC45FSL1H221J	CERAMIC 220PF J		
C207, 208			CE04LW1A101M	ELECTRØ 100UF 10WV		
C209, 210			CK45FB1H102K	CERAMIC 1000PF K		
C211, 212			CQ92FM1H123J	MYLAR 0.012UF J		
C213, 214			CQ92FM1H332J	MYLAR 3300PF J		
C215, 216			CE04LW1V4R7M	ELECTRØ 4.7UF 35WV		
C219			CK45FB1H681K	CERAMIC 680PF K		
C220			CK45FF1H103Z	CERAMIC 0.010UF Z		
C221-236			C91-0749-05	CERAMIC 220PF K	TE	
C223, 224			C91-0749-05	CERAMIC 220PF K	KPYMX	7
C223, 224			C91-0749-05	CERAMIC 220PF K	KPYMXT	6
C227, 228			C91-0749-05	CERAMIC 220PF K	KPYMX	7
C227, 228			C91-0749-05	CERAMIC 220PF K	KPYMXT	6
C231, 232			C91-0749-05	CERAMIC 220PF K	KPYMX	7
C231, 232			C91-0749-05	CERAMIC 220PF K	KPYMXT	6
C237, 238			CE04LW1V4R7M	ELECTRØ 4.7UF 35WV		
C239-242			CC45FSL1H221J	CERAMIC 220PF J	TE	
C239, 240			CC45FSL1H221J	CERAMIC 220PF J	KPYMX	7
C239, 240			CC45FSL1H221J	CERAMIC 220PF J	KPYMXT	6
C243			CC45FSL1H101J	CERAMIC 100PF J		
C244			CK45FF1H103Z	CERAMIC 0.010UF Z		
C245, 246			CE04LW1V100M	ELECTRØ 10UF 35WV		
C247, 248			CE04LW1C101M	ELECTRØ 100UF 16WV		
C249, 250			CK45FF1H103Z	CERAMIC 0.010UF Z		
C251, 252			CE04LW1C470M	ELECTRØ 47UF 16WV		
C253			CK45FB1H102K	CERAMIC 1000PF K		
C254			CE04LW1C470M	ELECTRØ 47UF 16WV		
C255			CK45FB1H102K	CERAMIC 1000PF K		
C256			CE04LW1C470M	ELECTRØ 47UF 16WV		
C257			CK45FB1H102K	CERAMIC 1000PF K		
C258			CE04LW1C470M	ELECTRØ 47UF 16WV		
C259			CE04LW1V100M	ELECTRØ 10UF 35WV		
C260			CE04LW1H2R2M	ELECTRØ 2.2UF 50WV		
C261			CE04LW1V100M	ELECTRØ 10UF 35WV		
C262			CC45FSL1H101J	CERAMIC 100PF J		
C263-270			CK45FF1H103Z	CERAMIC 0.010UF Z		
C271			CE04LW1A101M	ELECTRØ 100UF 10WV		
C301, 302			CE04LW1V100M	ELECTRØ 10UF 35WV		7
C301, 302			CE04LW1V100M	ELECTRØ 10UF 35WV	KPYMXT	6
C303, 304			CF92FV1H224J	MF 0.22UF J		7
C303, 304			CF92FV1H224J	MF 0.22UF J	KPYMXT	6
C305, 306			CE04LW1V4R7M	ELECTRØ 4.7UF 35WV		7
C305, 306			CE04LW1V4R7M	ELECTRØ 4.7UF 35WV	KPYMXT	6
C307			CE04LW1V100M	ELECTRØ 10UF 35WV		7
C307			CE04LW1V100M	ELECTRØ 10UF 35WV	KPYMXT	6
C308			CQ92FM1H682J	MYLAR 6800PF J		7
C308			CQ92FM1H682J	MYLAR 6800PF J	KPYMXT	6
C309, 310			CK45FF1H103Z	CERAMIC 0.010UF Z		7
C309, 310			CK45FF1H103Z	CERAMIC 0.010UF Z	KPYMXT	6

L:Scandinavia

K:USA

P:Canada

Y:PX(Far East, Hawaii)

T:England

E:Europe

6 : KR-V6050

Y:AAFES(Europe)

X:Australia

M:Other Areas

7 : KR-V7050

△ indicates safety critical components

KR-V6050/7050

For Service Manuals Contact
MAURITRON TECHNICAL SERVICES
 8 Cherry Tree Rd, Chinnor
 Oxon OX9 4QY
 Tel: 01844-351694 Fax: 01844-352554
 Email: enquiries@mauritron.co.uk

PARTS LIST

× New Parts

Parts without Parts No. are not supplied.

Les articles non mentionnés dans le Parts No. ne sont pas fournis.

Teile ohne Parts No. werden nicht geliefert.

Ref. No. 参照番号	Address 位置	New Parts 新	Parts No. 部品番号	Description 部品名 / 規格	Desti- nation 仕 向	Re- marks 備考
C311			CE04LW1A101M	ELECTRØ 100UF 10WV		7
C311			CE04LW1A101M	ELECTRØ 100UF 10WV	KPYMXT	6
C312			CF92FV1H104J	MF 0.10UF J		7
C312			CF92FV1H104J	MF 0.10UF J	KPYMXT	6
C313-315			CE04LW1V100M	ELECTRØ 10UF 35WV		7
C313-315			CE04LW1V100M	ELECTRØ 10UF 35WV	KPYMXT	6
C316			CF92FV1H104J	MF 0.10UF J		7
C316			CF92FV1H104J	MF 0.10UF J	KPYMXT	6
C317			CE04LW1H010M	ELECTRØ 1.0UF 50WV		7
C317			CE04LW1H010M	ELECTRØ 1.0UF 50WV	KPYMXT	6
C318-321			CQ92FM1H223J	MYLAR 0.022UF J		7
C318-321			CQ92FM1H223J	MYLAR 0.022UF J	KPYMXT	6
C322-325			CF92FV1H334J	MF 0.33UF J		7
C322-325			CF92FV1H334J	MF 0.33UF J	KPYMXT	6
C326, 327			CF92FV1H224J	MF 0.22UF J		7
C326, 327			CF92FV1H224J	MF 0.22UF J	KPYMXT	6
C328			CK45FB1H681K	CERAMIC 680PF K		7
C328			CK45FB1H681K	CERAMIC 680PF K	KPYMXT	6
C329, 330			CF92FV1H104J	MF 0.10UF J		7
C329, 330			CF92FV1H104J	MF 0.10UF J	KPYMXT	6
C331			CK45FB1H681K	CERAMIC 680PF K		7
C331			CK45FB1H681K	CERAMIC 680PF K	KPYMXT	6
C332, 333			CF92FV1H104J	MF 0.10UF J		7
C332, 333			CF92FV1H104J	MF 0.10UF J	KPYMXT	6
C334			CK45FF1H103Z	CERAMIC 0.010UF Z		7
C334			CK45FF1H103Z	CERAMIC 0.010UF Z	KPYMXT	6
C335			CE04LW1A101M	ELECTRØ 100UF 10WV		7
C335			CE04LW1A101M	ELECTRØ 100UF 10WV	KPYMXT	6
C336			CF92FV1H104J	MF 0.10UF J		7
C336			CF92FV1H104J	MF 0.10UF J	KPYMXT	6
C337			CE04HW1E4R7M	NP-ELEC 4.7UF 25WV		7
C337			CE04HW1E4R7M	NP-ELEC 4.7UF 25WV	KPYMXT	6
C338			CE04LW1V100M	ELECTRØ 10UF 35WV		7
C338			CE04LW1V100M	ELECTRØ 10UF 35WV	KPYMXT	6
C339			CF92FV1H104J	MF 0.10UF J		7
C339			CF92FV1H104J	MF 0.10UF J	KPYMXT	6
C340, 341			CC45FSL1H101J	CERAMIC 100PF J		7
C340, 341			CC45FSL1H101J	CERAMIC 100PF J	KPYMXT	6
C342			CE04LW1H010M	ELECTRØ 1.0UF 50WV		7
C342			CE04LW1H010M	ELECTRØ 1.0UF 50WV	KPYMXT	6
C344			CE04LW1V100M	ELECTRØ 10UF 35WV		7
C344			CE04LW1V100M	ELECTRØ 10UF 35WV	KPYMXT	6
C345, 346			CE04LW1HR22M	ELECTRØ 0.22UF 50WV		7
C345, 346			CE04LW1HR22M	ELECTRØ 0.22UF 50WV	KPYMXT	6
C347			CC45FSL1H101J	CERAMIC 100PF J		7
C347			CC45FSL1H101J	CERAMIC 100PF J	KPYMXT	6
C348			CE04LW1H010M	ELECTRØ 1.0UF 50WV		7
C348			CE04LW1H010M	ELECTRØ 1.0UF 50WV	KPYMXT	6
C349			CE04LW1V4R7M	ELECTRØ 4.7UF 35WV		7
C349			CE04LW1V4R7M	ELECTRØ 4.7UF 35WV	KPYMXT	6
C350			CQ92FM1H103J	MYLAR 0.010UF J		7
C350			CQ92FM1H103J	MYLAR 0.010UF J	KPYMXT	6
C351			CQ92FM1H123J	MYLAR 0.012UF J		7
C351			CQ92FM1H123J	MYLAR 0.012UF J	KPYMXT	6
C352			CK45FB1H821K	CERAMIC 820PF K		7

L:Scandinavia

K:USA

P:Canada

Y:PX(Far East, Hawaii)

T:England

E:Europe

6 : KR-V6050

Y:AAFES(Europe)

X:Australia

M:Other Areas

7 : KR-V7050

⚠ indicates safety critical components.

KR-V6050/7050

PARTS LIST

× New Parts

Parts without Parts No. are not supplied.

Les articles non mentionnés dans le Parts No. ne sont pas fournis.

Teile ohne Parts No. werden nicht geliefert.

Ref. No. 参照番号	Address 位置	New Parts 新	Parts No. 部品番号	Description 部品名 / 規格	Desti- nation 仕 向	Re- marks 備考
C352			CK45FB1H021K	CERAMIC 820PF K	KPYMXT	6
C353			CQ92FM1H103J	MYLAR 0.010UF J		7
C353			CQ92FM1H103J	MYLAR 0.010UF J	KPYMXT	6
C354			CQ92FM1H123J	MYLAR 0.012UF J		7
C354			CQ92FM1H123J	MYLAR 0.012UF J	KPYMXT	6
C355			CK45FB1H021K	CERAMIC 820PF K		7
C355			CK45FB1H021K	CERAMIC 820PF K	KPYMXT	6
C356			CE04LW1V4R7M	ELECTRO 4.7UF 35WV		7
C356			CE04LW1V4R7M	ELECTRO 4.7UF 35WV	KPYMXT	6
C357			CE04LW1A101M	ELECTRO 100UF 10WV		7
C357			CE04LW1A101M	ELECTRO 100UF 10WV	KPYMXT	6
C358			CQ92FM1H392J	MYLAR 3900PF J		7
C358			CQ92FM1H392J	MYLAR 3900PF J	KPYMXT	6
C359			CE04LW1A101M	ELECTRO 100UF 10WV		7
C359			CE04LW1A101M	ELECTRO 100UF 10WV	KPYMXT	6
C360			CF92FV1H104J	MF 0.10UF J		7
C360			CF92FV1H104J	MF 0.10UF J	KPYMXT	6
C361			CE04LW1A101M	ELECTRO 100UF 10WV		7
C361			CE04LW1A101M	ELECTRO 100UF 10WV	KPYMXT	6
C362			CE04LW1V100M	ELECTRO 10UF 35WV		7
C362			CE04LW1V100M	ELECTRO 10UF 35WV	KPYMXT	6
C363			CE04LW1A101M	ELECTRO 100UF 10WV		7
C363			CE04LW1A101M	ELECTRO 100UF 10WV	KPYMXT	6
C364			CF92FV1H104J	MF 0.10UF J		7
C364			CF92FV1H104J	MF 0.10UF J	KPYMXT	6
C365			CK45FF1H103Z	CERAMIC 0.010UF Z		7
C365			CK45FF1H103Z	CERAMIC 0.010UF Z	KPYMXT	6
C366			CE04LW1A101M	ELECTRO 100UF 10WV		7
C366			CE04LW1A101M	ELECTRO 100UF 10WV	KPYMXT	6
C367, 368			CE04LW1V100M	ELECTRO 10UF 35WV		7
C367, 368			CE04LW1V100M	ELECTRO 10UF 35WV	KPYMXT	6
C369			CC45FSL1H101J	CERAMIC 100PF J		7
C369			CC45FSL1H101J	CERAMIC 100PF J	KPYMXT	6
C370			CQ92FM1H222J	MYLAR 2200PF J		7
C370			CQ92FM1H222J	MYLAR 2200PF J	KPYMXT	6
C371			CQ92FM1H102J	MYLAR 1000PF J		7
C371			CQ92FM1H102J	MYLAR 1000PF J	KPYMXT	6
C372			CE04LW1V100M	ELECTRO 10UF 35WV		7
C372			CE04LW1V100M	ELECTRO 10UF 35WV	KPYMXT	6
C373			CE04LW1H010M	ELECTRO 1.0UF 50WV		7
C373			CE04LW1H010M	ELECTRO 1.0UF 50WV	KPYMXT	6
C374			CE04LW1C470M	ELECTRO 47UF 16WV		7
C374			CE04LW1C470M	ELECTRO 47UF 16WV	KPYMXT	6
C375			CF92FV1H104J	MF 0.10UF J		7
C375			CF92FV1H104J	MF 0.10UF J	KPYMXT	6
C376			CF92FV1H334J	MF 0.33UF J		7
C376			CF92FV1H334J	MF 0.33UF J	KPYMXT	6
C377			CF92FV1H333J	MF 0.033UF J		7
C377			CF92FV1H333J	MF 0.033UF J	KPYMXT	6
C378			CQ92FM1H472J	MYLAR 4700PF J		7
C378			CQ92FM1H472J	MYLAR 4700PF J	KPYMXT	6
C379			CF92FV1H273J	MF 0.027UF J		7
C379			CF92FV1H273J	MF 0.027UF J	KPYMXT	6
C380			CE04LW1C220M	ELECTRO 22UF 16WV		7
C380			CE04LW1C220M	ELECTRO 22UF 16WV	KPYMXT	6

L:Scandinavia

K:USA

P:Canada

Y:PX(Far East, Hawaii)

T:England

E:Europe

6 : KR-V6050

Y:AAFES(Europe)

X:Australia

M:Other Areas

7 : KR-V7050

⚠ indicates safety critical components.

KR-V6050/7050

PARTS LIST

× New Parts

Parts without Parts No. are not supplied.

Les articles non mentionnes dans le Parts No. ne sont pas fournis.

Teile ohne Parts No. werden nicht geliefert.

Ref. No. 参照番号	Address 位置	New Parts 新	Parts No. 部品番号	Description 部品名 / 規格	Desti- nation 仕向	Re- marks 備考
C381			CE04LW1A101M	ELECTRØ 100UF 10WV		7
C381			CE04LW1A101M	ELECTRØ 100UF 10WV	KPYMXT	6
C382			CQ92FM1H822J	MYLAR 8200PF J		7
C382			CQ92FM1H822J	MYLAR 8200PF J	KPYMXT	6
C383			CE04LW1V100M	ELECTRØ 10UF 35WV		7
C383			CE04LW1V100M	ELECTRØ 10UF 35WV	KPYMXT	6
C384			CE04LW1H010M	ELECTRØ 1.0UF 50WV		7
C384			CE04LW1H010M	ELECTRØ 1.0UF 50WV	KPYMXT	6
C385			CE04LW1HOR1M	ELECTRØ 0.1UF 50WV		7
C385			CE04LW1HOR1M	ELECTRØ 0.1UF 50WV	KPYMXT	6
C386			CC45FSL1H101J	CERAMIC 100PF J		7
C386			CC45FSL1H101J	CERAMIC 100PF J	KPYMXT	6
C387			CE04LW1V4R7M	ELECTRØ 4.7UF 35WV		7
C387			CE04LW1V4R7M	ELECTRØ 4.7UF 35WV	KPYMXT	6
C388			CE04LW1HOR1M	ELECTRØ 0.1UF 50WV		7
C388			CE04LW1HOR1M	ELECTRØ 0.1UF 50WV	KPYMXT	6
C389			CE04LW1V4R7M	ELECTRØ 4.7UF 35WV		7
C389			CE04LW1V4R7M	ELECTRØ 4.7UF 35WV	KPYMXT	6
C389			CE04LW1V4R7M	ELECTRØ 4.7UF 35WV		7
C390			CE04LW1HOR1M	ELECTRØ 0.1UF 50WV		7
C390			CE04LW1HOR1M	ELECTRØ 0.1UF 50WV	KPYMXT	6
C391			CE04LW1V4R7M	ELECTRØ 4.7UF 35WV		7
C391			CE04LW1V4R7M	ELECTRØ 4.7UF 35WV	KPYMXT	6
C392			CC45FSL1H101J	CERAMIC 100PF J		7
C392			CC45FSL1H101J	CERAMIC 100PF J	KPYMXT	6
C393			CE04LW1HOR1M	ELECTRØ 0.1UF 50WV		7
C393			CE04LW1HOR1M	ELECTRØ 0.1UF 50WV	KPYMXT	6
C394			CE04LW1V4R7M	ELECTRØ 4.7UF 35WV		7
C394			CE04LW1V4R7M	ELECTRØ 4.7UF 35WV	KPYMXT	6
C394			CE04LW1V4R7M	ELECTRØ 4.7UF 35WV		7
C395, 396			CE04LW1V100M	ELECTRØ 10UF 35WV		7
C395, 396			CE04LW1V100M	ELECTRØ 10UF 35WV	KPYMXT	6
C397			CK45FB1H102K	CERAMIC 1000PF K		7
C397			CK45FB1H102K	CERAMIC 1000PF K	KPYMXT	6
C398			CE04LW1H010M	ELECTRØ 1.0UF 50WV		7
C398			CE04LW1H010M	ELECTRØ 1.0UF 50WV	KPYMXT	6
C398			CE04LW1H010M	ELECTRØ 1.0UF 50WV		7
C399			CQ92FM1H392J	MYLAR 3900PF J		7
C399			CQ92FM1H392J	MYLAR 3900PF J	KPYMXT	6
C401-403			C90-3242-05	ELECTRØ 4.7UF 35WV		7
C401-403			C90-3242-05	ELECTRØ 4.7UF 35WV		7
C404			CE04LW1E101M	ELECTRØ 100UF 25WV		7
C404			CE04LW1E101M	ELECTRØ 100UF 25WV		7
C405			CK45FF1H103Z	CERAMIC 0.010UF Z		7
C405			CK45FF1H103Z	CERAMIC 0.010UF Z		7
C406			CE04LW1V100M	ELECTRØ 10UF 35WV		7
C406			CE04LW1V100M	ELECTRØ 10UF 35WV		7
C408			CE04LW1V100M	ELECTRØ 10UF 35WV		7
C408			CE04LW1V100M	ELECTRØ 10UF 35WV		7
C409			CE04LW1V4R7M	ELECTRØ 4.7UF 35WV		7
C409			CE04LW1V4R7M	ELECTRØ 4.7UF 35WV		7
C410			CQ92FM1H103J	MYLAR 0.010UF J		7
C410			CQ92FM1H103J	MYLAR 0.010UF J		7
C411			CK45FB1H821K	CERAMIC 820PF K		7
C411			CK45FB1H821K	CERAMIC 820PF K		7
C412			CQ92FM1H123J	MYLAR 0.012UF J		7
C412			CQ92FM1H123J	MYLAR 0.012UF J		7
C413			CQ92FM1H103J	MYLAR 0.010UF J		7
C413			CQ92FM1H103J	MYLAR 0.010UF J		7
C414			CK45FB1H821K	CERAMIC 820PF K		7
C414			CK45FB1H821K	CERAMIC 820PF K		7
C415			CQ92FM1H123J	MYLAR 0.012UF J		7
C415			CQ92FM1H123J	MYLAR 0.012UF J		7
C416			C90-3242-05	ELECTRØ 4.7UF 35WV		7
C416			C90-3242-05	ELECTRØ 4.7UF 35WV		7
C417			C90-3205-05	ELECTRØ 100UF 4WV		7
C417			C90-3205-05	ELECTRØ 100UF 4WV		7
C418			CQ92FM1H392J	MYLAR 3900PF J		7
C418			CQ92FM1H392J	MYLAR 3900PF J		7
C419			CE04LW1A101M	ELECTRØ 100UF 10WV		7
C419			CE04LW1A101M	ELECTRØ 100UF 10WV		7
C420, 421			CF92FV1H104J	MF 0.10UF J		7
C420, 421			CF92FV1H104J	MF 0.10UF J		7
C422, 423			CE04LW1A101M	ELECTRØ 100UF 10WV		7
C422, 423			CE04LW1A101M	ELECTRØ 100UF 10WV		7
C424			CC45FSL1H101J	CERAMIC 100PF J		7
C424			CC45FSL1H101J	CERAMIC 100PF J		7

L:Scandinavia

K:USA

P:Canada

Y:PX(Far East, Hawaii)

T:England

E:Europe

6 : KR-V6050

Y:AAFES(Europe)

X:Australia

M:Other Areas

7 : KR-V7050

⚠ indicates safety critical components.

KR-V6050/7050

PARTS LIST

× New Parts

Parts without Parts No. are not supplied.

Les articles non mentionnés dans le Parts No. ne sont pas fournis.

Teile ohne Parts No. werden nicht geliefert.

For Service Manuals Contact
MAURITRON TECHNICAL SERVICES

8 Cherry Tree Rd. Chinnor

Oxon OX9 4QY

Tel: 01844-351694 Fax: 01844-352554

Email: enquiries@mauritron.co.uk

Ref. No. 参照番号	Address 位置	New Parts 新	Parts No. 部品番号	Description 部品名 / 規格	Desti- nation 仕 向	Re- marks 備考
C425			CQ92FM1H123J	MYLAR 0.012UF J		7
C426			CQ92FM1H112J	MYLAR 1100PF J		7
C427			CQ92FM1H133J	MYLAR 0.013UF J		7
C428			CQ92FM1H123J	MYLAR 0.012UF J		7
C429			CQ92FM1H112J	MYLAR 1100PF J		7
C430			CQ92FM1H133J	MYLAR 0.013UF J		7
C431,432			CE04LW1H010M	ELECTRO 1.0UF 50WV		7
C433,434			CC45FSL1H100D	CERAMIC 10PF D		7
C435			CE04LW1V100M	ELECTRO 10UF 35WV		7
C442			CE04LW1V100M	ELECTRO 10UF 35WV		7
C443,444		*	CE04LW1HR1M	ELECTRO 0.1MUF 50WV		7
C445,446			CE04LW1V100M	ELECTRO 10UF 35WV		7
C447			CK45FB1H102K	CERAMIC 1000PF K		7
C448			CC45FSL1H101J	CERAMIC 100PF J		7
C501-506			CQ92FM1H102J	MYLAR 1000PF J	KPYMXT	6
C501-506			CE04LW1V100M	ELECTRO 10UF 35WV		7
C507			CE04LW1V100M	ELECTRO 10UF 35WV	KPYMXT	6
CN3	1B		E40-4163-05	FLAT CABLE CONNECTOR	KPX	
CN3	1B		E40-4167-05	FLAT CABLE CONNECTOR	YMTE	
J1			E20-0321-05	LOCK TERMINAL BOARD ANTENNA	TE	
J1			E20-0476-05	LOCK TERMINAL BOARD ANTENNA	KPYMX	
J201			E63-0068-05	PHONE JACK PHONE		
J202,203			E63-0070-05	PHONE JACK CD, TAPE, VIDEO		
-			J11-0098-05	WIRE CLAMPER		6
CF1 ,2			L72-0531-05	CERAMIC FILTER	KPYMX	
CF1 ,2			L72-0536-05	CERAMIC FILTER	TE	
L1			L30-0467-05	AM IFT		
L2			L30-0439-25	FM IFT	KP	
L2			L30-0484-05	FM IFT	TE	
L2			L30-0494-05	FM IFT	YMX	
L3			L40-1021-14	SMALL FIXED INDUCTOR(1.0MH,K)		
L6 ,7			L79-0790-05	LC FILTER	TE	
L8			L40-1091-17	SMALL FIXED INDUCTOR		
L9			L30-0485-05	FM IFT	TE	
L10			L40-1091-17	SMALL FIXED INDUCTOR	TE	
L11 -13			L40-1091-17	SMALL FIXED INDUCTOR	KPYMX	6
L106			L40-1091-17	SMALL FIXED INDUCTOR		
L107			L39-1309-05	COMBINATION COIL		
L108			L79-0125-05	LC FILTER	TE	
L301,302			L40-1091-17	SMALL FIXED INDUCTOR		7
L301,302			L40-1091-17	SMALL FIXED INDUCTOR	KPYMXT	6
L401,402			L40-1091-17	SMALL FIXED INDUCTOR		7
X1			L77-1122-05	CRYSTAL RESONATOR 7.200MHZ		
X2			L78-0295-05	RESONATOR 19.000kHz		
X301			L78-0601-05	RESONATOR 7.160MHZ		7
X301			L78-0601-05	RESONATOR 7.160MHZ	KPYMXT	6
X401			L78-0601-05	RESONATOR 7.160MHZ		7
C	1B		N09-0333-05	TAPPING SCREW (3X12)		
H	1B		N89-3008-46	BINDING HEAD TAPTITE SCREW		
R8			RD14NB2E101J	RD 100 J 1/4W		
R21			RD14NB2E470J	RD 47 J 1/4W	TE	

L:Scandinavia

K:USA

P:Canada

Y:PX(Far East, Hawaii)

T:England

E:Europe

6 : KR-V6050

Y:AAFES(Europe)

X:Australia

M:Other Areas

7 : KR-V7050

△ indicates safety critical components.

KR-V6050/7050

PARTS LIST

× New Parts

Parts without Parts No. are not supplied.

Les articles non mentionnés dans le Parts No. ne sont pas fournis.

Teile ohne Parts No. werden nicht geliefert.

Ref. No. 参照番号	Address 位置	New Parts 新	Parts No. 部品番号	Description 部品名 / 規格	Desti- nation 仕向	Re- marks 備考
R21			RD14NB2E680J	RD 68 J 1/4W	KPYMX	
R37			RD14NB2E101J	RD 100 J 1/4W		
R53			RS14KB3D221J	FL-PROOF RS 220 J 2W		
R111			RD14NB2E101J	RD 100 J 1/4W		
R177			RS14KB3D221J	FL-PROOF RS 220 J 2W	TE	
R261			RD14NB2E101J	RD 100 J 1/4W		
R276			RS14KB3A101J	FL-PROOF RS 100 J 1W		
R303, 304			RS14KB3D181J	FL-PROOF RS 180 J 2W		7
R303, 304			RS14KB3D181J	FL-PROOF RS 180 J 2W	KPYMXT	6
R352			RD14NB2E470J	RD 47 J 1/4W		7
R352			RD14NB2E470J	RD 47 J 1/4W	KPYMXT	6
R374, 375			RD14NB2E101J	RD 100 J 1/4W		
R374, 375			RD14NB2E101J	RD 100 J 1/4W	KPYMXT	6
VR1			R12-3688-05	TRIMMING POT.(47K) FM TUNED		
VR3			R12-3686-05	TRIMMING POT.(22K) AM TUNED		
VR5			R12-6663-05	TRIMMING POT.(330K)SEPARATION		
S101			S31-2132-05	SLIDE SWITCH DE ENPHASYS,CH	YM	
S401			S31-2132-05	SLIDE SWITCH IMPEDANCE SELECT		7
D3			HZ55.1N(B2)	ZENER DIODE		
D3			RD5.1ES(B2)	ZENER DIODE		
D6 ,7			HSS104	DIODE	TE	
D6 ,7			1SS133	DIODE	TE	
D111, 112			HSS104	DIODE		
D111, 112			1SS133	DIODE		
D117-121			HSS104	DIODE	TE	
D117-121			1SS133	DIODE	TE	
D123			HZ55.1N(B2)	ZENER DIODE	TE	
D123			RD5.1ES(B2)	ZENER DIODE	TE	
D124			HZ513N(B2)	ZENER DIODE		
D124			RD13ES(B2)	ZENER DIODE		
D125			HSS104	DIODE	TE	
D125			1SS133	DIODE	TE	
D201			HZ56.2N(B2)	ZENER DIODE		
D201			RD6.2ES(B2)	ZENER DIODE		
D202			HZ58.2N(B2)	ZENER DIODE		
D202			RD8.2ES(B2)	ZENER DIODE		
D203			HZ53.9N(B2)	ZENER DIODE		
D203			RD3.9ES(B2)	ZENER DIODE		
D204			HZ55.6N(B2)	ZENER DIODE		
D204			RD5.6ES(B2)	ZENER DIODE		
D205-214			HSS104	DIODE		
D205-214			1SS133	DIODE		
D301			HZ55.6N(B2)	ZENER DIODE		7
D301			HZ55.6N(B2)	ZENER DIODE	KPYMXT	6
D301			RD5.6ES(B2)	ZENER DIODE		7
D301			RD5.6ES(B2)	ZENER DIODE	KPYMXT	6
D302, 303			HZ56.2N(B2)	ZENER DIODE		7
D302, 303			HZ56.2N(B2)	ZENER DIODE	KPYMXT	6
D302, 303			RD6.2ES(B2)	ZENER DIODE		7
D302, 303			RD6.2ES(B2)	ZENER DIODE	KPYMXT	6
D401			HZ55.6N(B2)	ZENER DIODE		7
D401			RD5.6ES(B2)	ZENER DIODE		7
D402-407			HSS104	DIODE		7

L:Scandinavia

K:USA

P:Canada

Y:PX(Far East, Hawaii)

T:England

E:Europe

6 : KR-V6050

Y:AAFES(Europe)

X:Australia

M:Other Areas

7 : KR-V7050

△ indicates safety critical components.

KR-V6050/7050

PARTS LIST

For Service Manuals Contact
MAURITRON TECHNICAL SERVICES
 8 Cherry Tree Rd, Chinnor
 Oxon OX9 4QY
 Tel:- 01844-351694 Fax:- 01844-352554
 Email:- enquiries@mauritron.co.uk

* New Parts

Parts without Parts No. are not supplied.

Les articles non mentionnés dans le Parts No. ne sont pas fournis.

Teile ohne Parts No. werden nicht geliefert.

Ref. No. 参照番号	Address 位置	New Parts 新	Parts No. 部品番号	Description 部品名 / 規格	Desti- nation 仕向	Re- marks 備考
D402-407			1SS133	DIODE		7
IC1			LA1266	IC(AM/FM IF)		
IC2			LA3401	IC(FM MPX)		
IC3			LC7218	IC(PLL SYNTHESIZER)		
IC4			M5223P	IC(OP AMP X2)	TE	
IC201			NJM4580D-D	IC(OP AMP X2)		
IC202			NJU7313L	IC(ANALOG SWITCH)		
IC203			NJU7311L	IC(ANALOG SWITCH)		
IC204			NJM4580D-D	IC(OP AMP X2)		
IC205			NJU7312L	IC(ANALOG SWITCH)		
IC301		*	SSM2126P	IC(DOLBY SURROUND DECODER)		7
IC301		*	SSM2126P	IC(DOLBY SURROUND DECODER)	KPYMXT	6
IC302			NE571N	IC(COMPANDOR)		7
IC302			NE571N	IC(COMPANDOR)	KPYMXT	6
IC303			NJM4565L	IC(OP AMP X2)		7
IC303			NJM4565L	IC(OP AMP X2)	KPYMXT	6
IC304			YM7128B	IC(DIGITAL SURROUND)		7
IC304			YM7128B	IC(DIGITAL SURROUND)	KPYMXT	6
IC305			M5238AL	IC(OPAMP X2)		7
IC305			M5238AL	IC(OPAMP X2)	KPYMXT	6
IC306			LA2730	IC(DOLBY SYSTEM)		7
IC306			LA2730	IC(DOLBY SYSTEM)	KPYMXT	6
IC307			TC9213P	IC(2CH ELECTRONIC VOLUME)		7
IC307			TC9213P	IC(2CH ELECTRONIC VOLUME)	KPYMXT	6
IC308-310			NJM4565L	IC(OP AMP X2)		7
IC308-310			NJM4565L	IC(OP AMP X2)	KPYMXT	6
IC401			NJM4565L	IC(OP AMP X2)		7
IC401			NJM4565L	IC(OP AMP X2)	KPYMXT	6
IC402			YM7128B	IC(DIGITAL SURROUND)		7
IC402			YM7128B	IC(DIGITAL SURROUND)	KPYMXT	6
IC403			M5238AL	IC(OPAMP X2)		7
IC403			M5238AL	IC(OPAMP X2)	KPYMXT	6
IC404, 405			NJM4565L	IC(OP AMP X2)		7
IC404, 405			NJM4565L	IC(OP AMP X2)	KPYMXT	6
IC406			TC9215P	IC(ANALOG SWITCH X 6)		7
IC407			UPC4574C	IC(OP AMP X4)		7
Q1			2SC1923(R, O)	TRANSISTOR		
Q2			2SC1845(F, E)	TRANSISTOR		
Q3			2SC1740S(Q, R)	TRANSISTOR	KPYMX	
Q3			2SC2785(F, E)	TRANSISTOR		KPYMX
Q3 ,4			2SC1740S(Q, R)	TRANSISTOR	TE	
Q3 ,4			2SC2785(F, E)	TRANSISTOR	TE	
Q7			2SC1740S(Q, R)	TRANSISTOR	KPYMX	
Q7			2SC2785(F, E)	TRANSISTOR	KPYMX	
Q7 ,8			2SC1740S(Q, R)	TRANSISTOR	TE	
Q7 ,8			2SC2785(F, E)	TRANSISTOR	TE	
Q9			2SA1175(F, E)	TRANSISTOR	TE	
Q9			2SA933S(Q, R)	TRANSISTOR	TE	
Q10			2SC1740S(Q, R)	TRANSISTOR	TE	
Q10			2SC2785(F, E)	TRANSISTOR	TE	
Q102			2SA1175(F, E)	TRANSISTOR		
Q102			2SA933S(Q, R)	TRANSISTOR		
Q104			2SA1175(F, E)	TRANSISTOR		
Q104			2SA933S(Q, R)	TRANSISTOR		
Q107, 108			2SC1740S(Q, R)	TRANSISTOR	YM	
Q107, 108			2SC2785(F, E)	TRANSISTOR	YM	
Q113			2SD2012	TRANSISTOR		
Q113			2SD2061	TRANSISTOR		
Q113			2SD2374	TRANSISTOR		

L:Scandinavia

K:USA

P:Canada

Y:PX(Far East, Hawaii)

T:England

E:Europe

6 : KR-V6050

Y:AAFES(Europe)

X:Australia

M:Other Areas

7 : KR-V7050

△ indicates safety critical components.

KR-V6050/7050

PARTS LIST

× New Parts

Parts without Parts No. are not supplied.

Les articles non mentionnes dans le Parts No. ne sont pas fournis.

Teile ohne Parts No. werden nicht geliefert.

Ref. No. 参照番号	Address 位置	New Parts 新	Parts No. 部品番号	Description 部品名/規格	Desti- nation 仕向	Re- marks 備考
Q201			2SD2012	TRANSISTOR		
Q201			2SD2061	TRANSISTOR		
Q201			2SD2374	TRANSISTOR		
Q202, 203			2SC1740S(Q,R)	TRANSISTOR		
Q202, 203			2SC2458(Y,GR)	TRANSISTOR		
Q202, 203			2SC2785(F,E)	TRANSISTOR		
Q202, 203			2SC3311A(Q,R)	TRANSISTOR		
Q204			2SD2012	TRANSISTOR		
Q204			2SD2061	TRANSISTOR		
Q204			2SD2374	TRANSISTOR		
Q205, 206			2SA1048(Y,GR)	TRANSISTOR		
Q205, 206			2SA1175(F,E)	TRANSISTOR		
Q205, 206			2SA1309A(Q,R)	TRANSISTOR		
Q205, 206			2SA933S(Q,R)	TRANSISTOR		
Q207, 208			2SC2878(B)	TRANSISTOR		
Q209, 210			2SC1740S(Q,R)	TRANSISTOR		
Q209, 210			2SC2458(Y,GR)	TRANSISTOR		
Q209, 210			2SC2785(F,E)	TRANSISTOR		
Q209, 210			2SC3311A(Q,R)	TRANSISTOR		
Q211			2SC2003(L,K)	TRANSISTOR		
Q212			2SA1048(Y,GR)	TRANSISTOR		
Q212			2SA1175(F,E)	TRANSISTOR		
Q212			2SA1309A(Q,R)	TRANSISTOR		
Q212			2SA933S(Q,R)	TRANSISTOR		
Q213			2SC1740S(Q,R)	TRANSISTOR		
Q213			2SC2458(Y,GR)	TRANSISTOR		
Q213			2SC2785(F,E)	TRANSISTOR		
Q213			2SC3311A(Q,R)	TRANSISTOR		
Q301			2SC2003(L,K)	TRANSISTOR	KPYMXT	7
Q301			2SC2003(L,K)	TRANSISTOR		6
Q303, 304			2SC1740S(Q,R)	TRANSISTOR		7
Q303, 304			2SC1740S(Q,R)	TRANSISTOR	KPYMXT	6
Q303, 304			2SC2458(Y,GR)	TRANSISTOR		7
Q303, 304			2SC2458(Y,GR)	TRANSISTOR	KPYMXT	6
Q303, 304			2SC2785(F,E)	TRANSISTOR		7
Q303, 304			2SC2785(F,E)	TRANSISTOR	KPYMXT	6
Q303, 304			2SC3311A(Q,R)	TRANSISTOR		7
Q303, 304			2SC3311A(Q,R)	TRANSISTOR	KPYMXT	6
Q306			2SC1740S(Q,R)	TRANSISTOR		7
Q306			2SC1740S(Q,R)	TRANSISTOR	KPYMXT	6
Q306			2SC2458(Y,GR)	TRANSISTOR		7
Q306			2SC2458(Y,GR)	TRANSISTOR	KPYMXT	6
Q306			2SC2785(F,E)	TRANSISTOR		7
Q306			2SC2785(F,E)	TRANSISTOR	KPYMXT	6
Q306			2SC3311A(Q,R)	TRANSISTOR		7
Q306			2SC3311A(Q,R)	TRANSISTOR	KPYMXT	6
Q401			2SC2003(L,K)	TRANSISTOR		7
Q403-406			2SC2878(B)	TRANSISTOR		7
			W02-1041-15	FM FRONT-END ASSY	TE	
			W02-1042-15	FM FRONT-END ASSY	KPYMX	

L:Scandinavia

K:USA

P:Canada

Y:PX(Far East, Hawaii)

T:England

E:Europe

6 : KR-V6050

Y:AAFES(Europe)

X:Australia

M:Other Areas

7 : KR-V7050

 indicates safety critical components.

KR-V6050/7050

SPECIFICATIONS

[K, P, M, X, Y type]

(For U.S.A. and Canada)

Audio section

Rated power output at the STEREO operation

100 watts per channel minimum RMS, both channels driven at 8 Ω, from 20 Hz to 20,000 Hz with no more than 0.06% total harmonic distortions. (FTC)

Power output at the Surround operation

Front (1 kHz, 0.9% T.H.D. at 8 Ω) 65 W + 65 W
 Center (1 kHz, 0.9% T.H.D. at 8 Ω) 65 W
 Rear (1 kHz, 0.9% T.H.D. at 8 Ω) 20 W + 20 W

Total harmonic distortion (1 kHz, 8 Ω) 0.03% at 50 W

Signal to noise ratio (IHF A)

PHONO (MM) 78 dB
 CD, TAPE, VIDEO 100 dB

Input sensitivity / impedance

PHONO (MM) 2.5 mV / 47 kΩ
 CD, TAPE, VIDEO 200 mV / 47 kΩ

Tone controls

BASS ±10 dB (at 100 Hz)
 TREBLE ±10 dB (at 10 kHz)

Loudness control at - 30 dB VOLUME level

..... 0 ~ + 8 dB (100 Hz)

Video section

VIDEO inputs / outputs(Composite) 1 Vp-p / 75 Ω

FM Tuner section

Tuning frequency range 87.5 MHz~108 MHz

Usable sensitivity (IHF) 10.8 dBf (0.95 μV at 75 Ω)

50 dB quieting sensitivity

MONO 17.2 dBf (2.0 μV at 75 Ω)

STEREO 41.2 dBf (32 μV at 75 Ω)

Total harmonic distortion at 1 kHz

MONO 0.4%

STEREO 0.5%

Signal to noise ratio at 65 dBf (IHF)

MONO 78 dB

STEREO 73 dB

Selectivity (IHF ±400 kHz) 53 dB

Stereo separation (IHF at 1 kHz) 45 dB

Frequency response .. 30 Hz~15 kHz, +0.5 dB,- 2.0 dB

AM Tuner section

Tuning frequency range 530 kHz~1,700 kHz

Usable sensitivity 12 μV / (400 μV / m)

Total harmonic distortion 0.3 %

Signal to noise ratio 50 dB

Selectivity 30 dB

General

Power consumption 3 A

AC outlet

SWITCHED 2: (total 200 W, 1.6 A max.)

Dimensions W:440 mm (17-5/16")

H:147 mm (5-13/16")

D:403 mm (15-7/8")

Weight (net) 11.4 kg (25.1 lb)

(For other countries)

Audio section

Rated power output at the STEREO operation

(IHF '66) from 20 Hz to 20 kHz,

0.06% T.H.D., at 8 Ω 100 W + 100 W

Power output at the Surround operation

Front (1 kHz, 0.9% T.H.D. at 8 Ω) 65 W + 65 W

Center (1 kHz, 0.9% T.H.D. at 8 Ω) 65 W

Rear (1 kHz, 0.9% T.H.D. at 8 Ω) 20 W + 20 W

Total harmonic distortion (1 kHz, 8 Ω) 0.03% at 50 W

Signal to noise ratio (IHF'66)

PHONO (MM) 78 dB

CD, TAPE, VIDEO 100 dB

Input sensitivity / impedance

PHONO (MM) 2.5 mV / 47 kΩ

CD, TAPE, VIDEO 200 mV / 47kΩ

Tone controls

BASS ±10 dB (at 100 Hz)

TREBLE ±10 dB (at 10 kHz)

Loudness control at - 30 dB VOLUME level

..... 0 ~ + 8 dB (100 Hz)

Video section

VIDEO inputs / outputs(Composite) 1 Vp-p / 75 Ω

FM Tuner section

Tuning frequency range 87.5 MHz~108 MHz

Usable sensitivity (IHF) 10.8 dBf (0.95 μV at 75 Ω)

50 dB quieting sensitivity

MONO 17.2 dBf (2.0 μV at 75 Ω)

STEREO 41.2 dBf (32 μV at 75 Ω)

Total harmonic distortion at 1 kHz

MONO 0.4 %

STEREO 0.5 %

Signal to noise ratio at 65 dBf (IHF)

MONO 78 dB

STEREO 73 dB

Selectivity (IHF ± 400 kHz) 53 dB

Stereo separation (IHF at 1 kHz) 45 dB

Frequency response . 30 Hz~15 kHz, + 0.5 dB,- 2.0 dB

AM Tuner section

Tuning frequency range

9 kHz 531 kHz ~ 1,602 kHz

10 kHz 530 kHz ~ 1,610 kHz

Usable sensitivity 12 μV / (400 μV / m)

Total harmonic distortion 0.3 %

Signal to noise ratio 50 dB

Selectivity 30 dB

General

Power consumption 280 W

AC outlet

SWITCHED 2: (total 200 W max.)

(Except for Australia)

Dimensions W:440 mm

H:147 mm

D:403 mm

Weight (net) 11.4 kg

Note:

KENWOOD follows a policy of continuous advancements in development. For this reason specifications may be changed without notice

KR-V6050/7050

SPECIFICATIONS

[E, T type]

Audio section

Rated power output at the STEREO operation
at 1 kHz, 8 Ω (DIN) ----- 100 W + 100 W

Power output at the Surround operation

Front (1 kHz, 0.9% at 8 Ω) ----- 65 W + 65 W

Center (1 kHz, 0.9% at 8 Ω) ----- 65 W

Rear (1 kHz, 0.9% at 8 Ω) ----- 20 W + 20 W

Total harmonic distortion (1 kHz, 8 Ω) 0.03% at 50 W

Signal to noise ratio

PHONO (MM) ----- 56 dB (DIN, 50 mW output)

CD, TAPE, VIDEO ----- 57dB (DIN, 50 mW output)

Input sensitivity / impedance

PHONO (MM) ----- 2.5 mV / 47 k Ω

CD, TAPE, VIDEO ----- 200 mV / 47k Ω

Tone controls

BASS ----- ± 10 dB (at 100 Hz)

TREBLE ----- ± 10 dB (at 10 kHz)

Loudness control at 30 dB

VOLUME level ----- 0 ~ + 8 dB (100 Hz)

Video section

VIDEO inputs/outputs
(composite) ----- 1 Vp-p/75 Ω

FM Tuner section

Tuning frequency range ----- 87.5 MHz~108 MHz

Usable sensitivity (DIN at 75 Ω)

MONO ----- 1.1 μ V

STEREO ----- 45 μ V

Total harmonic distortion at 1 kHz (DIN)

MONO ----- 0.15%

STEREO ----- 0.5%

Signal to noise ratio (DIN weighted at 1 kHz)

MONO ----- 68 dB (65.2 dBf input)

STEREO ----- 61 dB (65.2 dBf input)

Selectivity (DIN ± 300 kHz) ----- 53 dB

Stereo separation (DIN)

1 kHz ----- 40 dB

6.3 kHz ----- 33 dB

Frequency response ---- 30 Hz~15 kHz, + 0.5 dB,- 2.0 dB

AM Tuner section

Tuning frequency range ----- 531 kHz ~ 1,602 kHz

Usable sensitivity ----- 12 μ V / (400 μ V / m)

Total harmonic distortion ----- 0.3 %

Signal to noise ratio
(at 30% mod. 1mV input) ----- 50 dB

Selectivity ----- 30 dB

General

Power consumption ----- 280 W

AC outlet

SWITCHED ----- 2: (total 200 W max)

Dimensions ----- W:440 mm
H:147 mm
D:403 mm

Weight (net) ----- 11.4 kg

For Service Manuals Contact
MAURITRON TECHNICAL SERVICES
8 Cherry Tree Rd, Chinnor
Oxon OX9 4QY
Tel:- 01844-351694 Fax:- 01844-352554
Email:- enquiries@mauritron.co.uk