

AUDIO-VIDEO SURROUND RECEIVER

KR-V7080/V8080

SERVICE MANUAL

KENWOOD

© 1996-3/B51-5162-00 (K/K) 3823

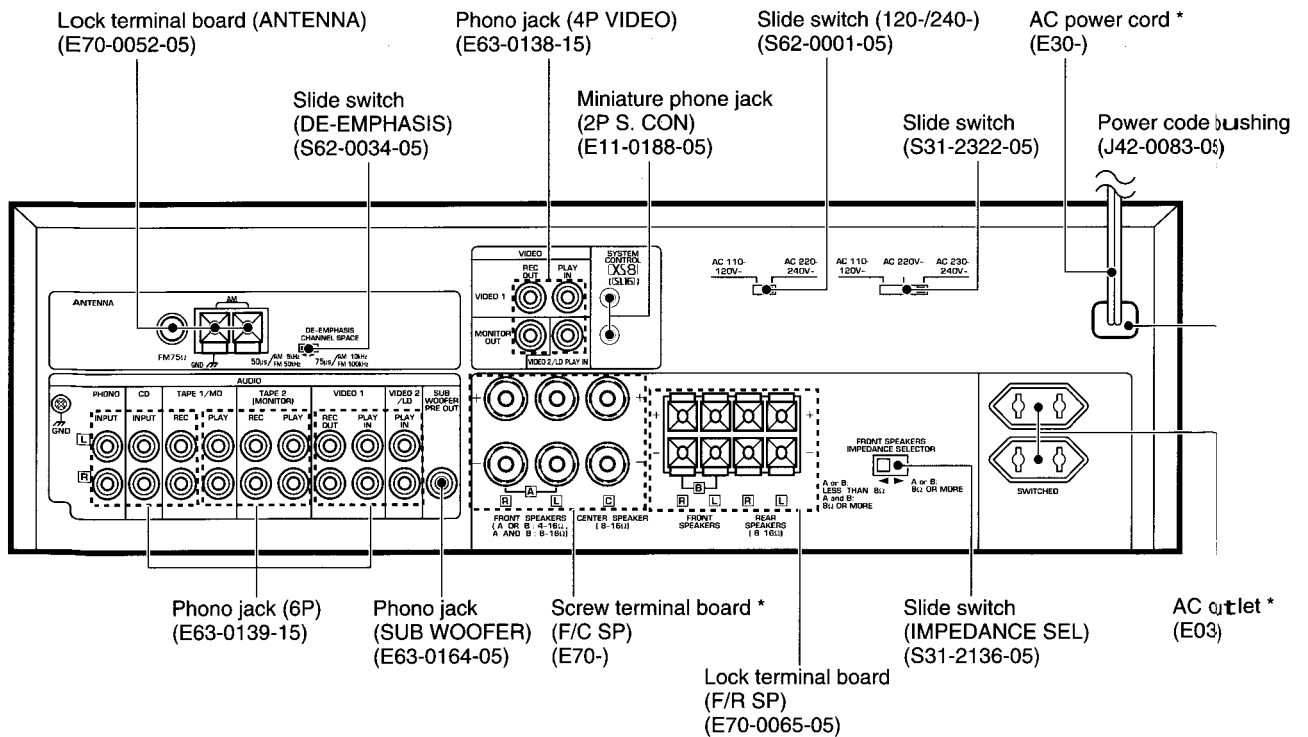
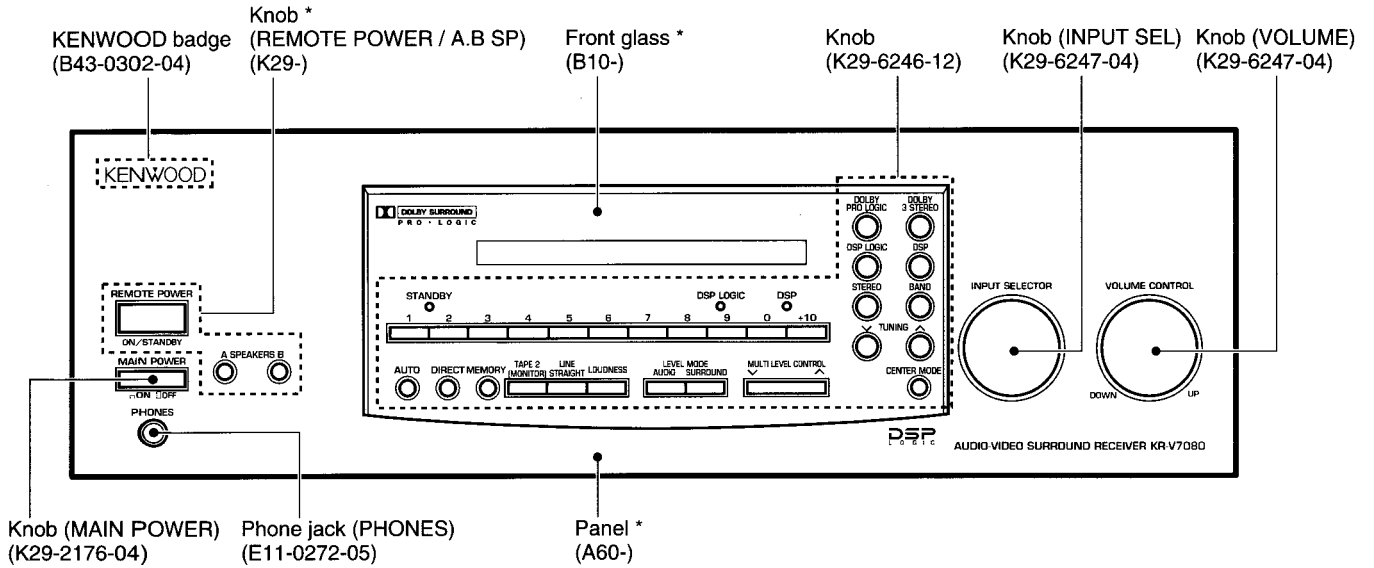

Illustration is KR-V7080.

* Refer to parts list on page 44.

KR-V7080/V8080

CONTENTS / ACCESSORIES

Contents

CONTENTS / ACCESSORIES	2	PC BOARD	18
CONTROLS	3	SCHEMATIC DIAGRAM	23
BLOCK DIAGRAM	5	EXPLODED VIEW (UNIT).....	43
CIRCUIT DESCRIPTION	6	PARTS LIST	44
ADJUSTMENT	16	SPECIFICATIONS	53
WIRING DIAGRAM	17		

Accessories

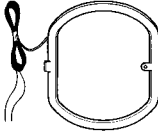
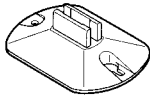
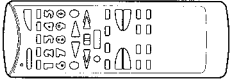
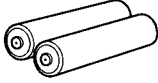
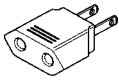
<p>FM indoor antenna(1) (T90-0810-05)</p> 	<p>AM loop antenna ass'y(1) (T90-0195-05)</p> 	<p>Loop antenna stand (J19-3645-05)</p> 
<p>Remote control unit(1) (A70-1042-05) : RC-R0803 for K,P,Y,X,M,C (A70-1042-05) : RC-R0803 for T,E BATTERY COVER : (A09-0169-08)</p> 	<p>Batteries (R6/AA)(2)</p> <p>(-)</p> 	<p>AC plug adaptor(1) (E03-0115-05) : M only</p> 

KR-V7080/V8080

CONTROLS

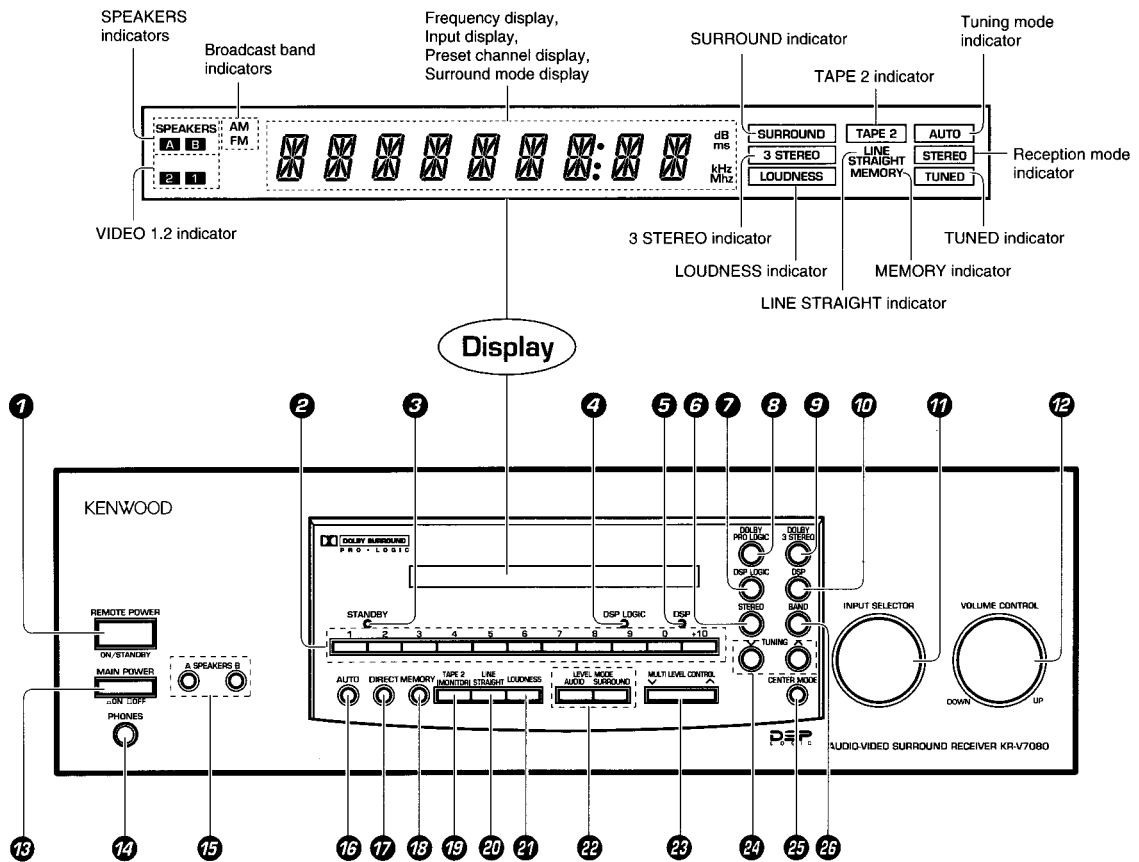

① REMOTE POWER key

Press to switch over the STANDBY/ON modes when the MAIN POWER is ON.

② NUMERIC KEYS

③ STANDBY indicator

④ DSP LOGIC indicator

Lights when the DSP LOGIC mode is ON.

⑤ DSP indicator

Lights when the DSP presence mode is ON.

⑥ STEREO key

Press to cancel the surround modes.

⑦ DSP LOGIC key

⑧ DOLBY PRO LOGIC key

⑨ DOLBY 3 STEREO key

⑩ DSP key

⑪ INPUT SELECTOR Knob

Turn to select the input sources.

⑫ VOLUME CONTROL Knob

⑬ MAIN POWER switch

Press to switch the main power ON/OFF.

⑭ PHONES jack

Used for headphone listening.

⑮ SPEAKERS A/B keys

Press to select the A and/or B speaker systems.

⑯ AUTO key

Press to select the auto tuning mode.

⑰ DIRECT key

Press for direct station tuning based on numerical input.

⑱ MEMORY key

Press to preset a station in the memory.

⑲ TAPE 2(MONITOR) key

Press to monitor the sound being recorded.

⑳ LINE STRAIGHT key

Press to listen to a source with high quality sound.

㉑ LOUDNESS key

Press to enhance low frequencies.

㉒ LEVEL MODE (AUDIO, SURROUND) keys

AUDIO key :

Press when adjusting the tone.

SURROUND key :

Press when adjusting the surround modes.

㉓ MULTI LEVEL CONTROL key

Press to adjust the tone or surround mode setting.

㉔ TUNING keys

Press to tune broadcast stations.

㉕ CENTER MODE key

Press to select the center mode in the DOLBY PRO LOGIC surround mode.

㉖ BAND key

Press to switch the broadcast band.

STANDBY mode of REMOTE POWER key

When the power cord of this system is plugged in to a power outlet and the MAIN POWER switch is pressed to ON, the STANDBY indicator lights up regardless of the REMOTE POWER key setting. This indicates that a small amount of current is being supplied to the unit to back up the memory contents. This mode is referred to as the Standby mode. While the STANDBY indicator is lit, the power of the system can also be switched ON/OFF from the remote control unit.

KR-V7080/V8080

REMOTE CONTROL OPERATION

The remote control unit provided with unit functions in the following two modes so that it can be used to control other KENWOOD system components as well as video components from other manufacturers.

KENWOOD component control mode This mode is used to control the KENWOOD source components including cassette decks and a CD player. (The controlled components must be connected to this unit through system control cords.)

Video component control mode This mode allows to control the basic operations of video components from KENWOOD as well as other manufacturers.

Some of the keys act in different ways depending on the modes described above. Therefore, be sure to adjust the required mode before pressing these keys.

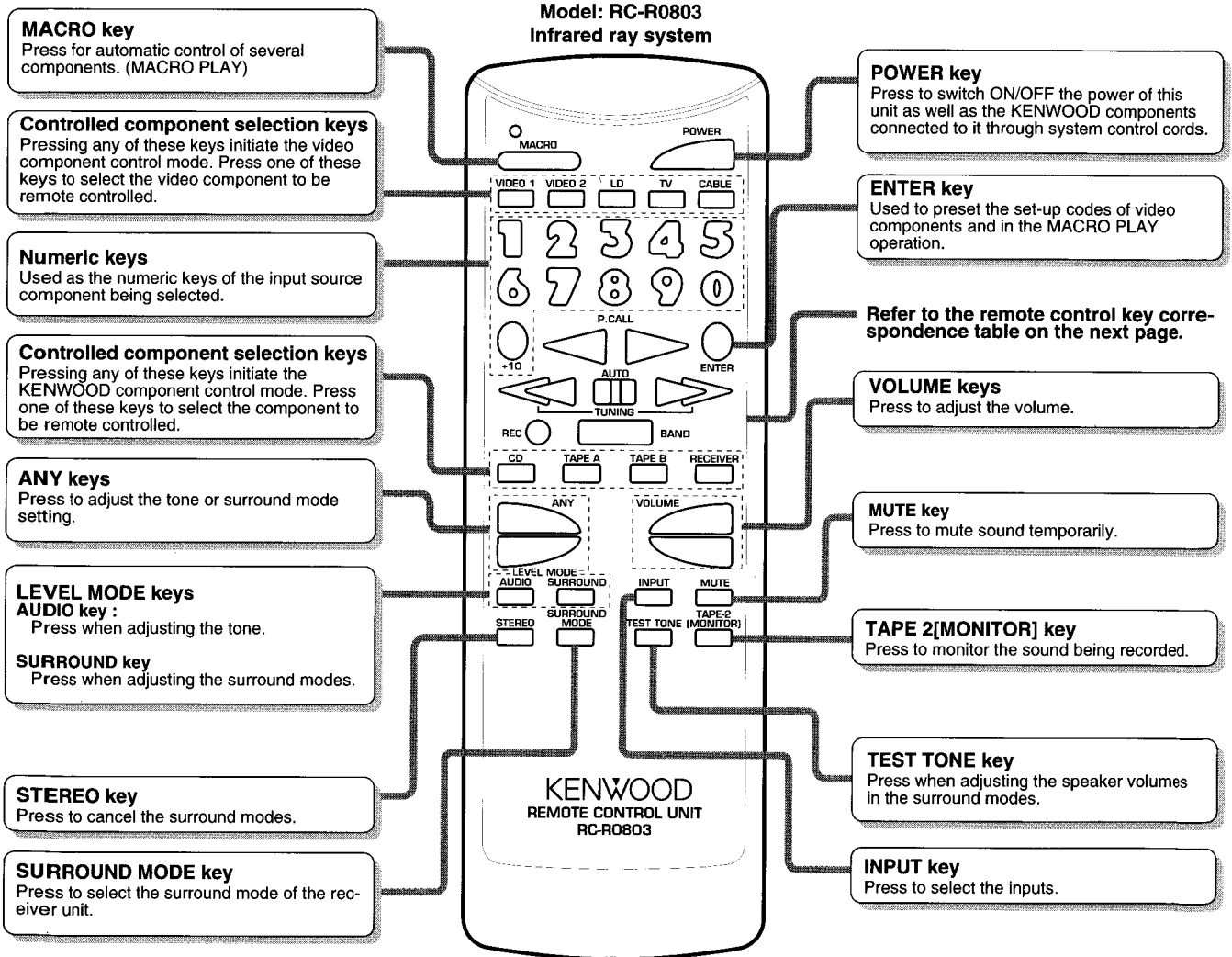

Loading batteries

① Remove the cover.

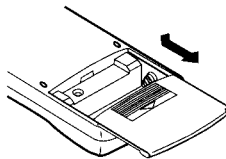

② Insert batteries.

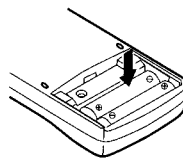

③ Close the cover.

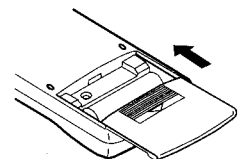

• Insert two AA-size (R6 / SUM-3) batteries as indicated by the polarity marking.

KR-V7080/V8080

BLOCK DIAGRAM

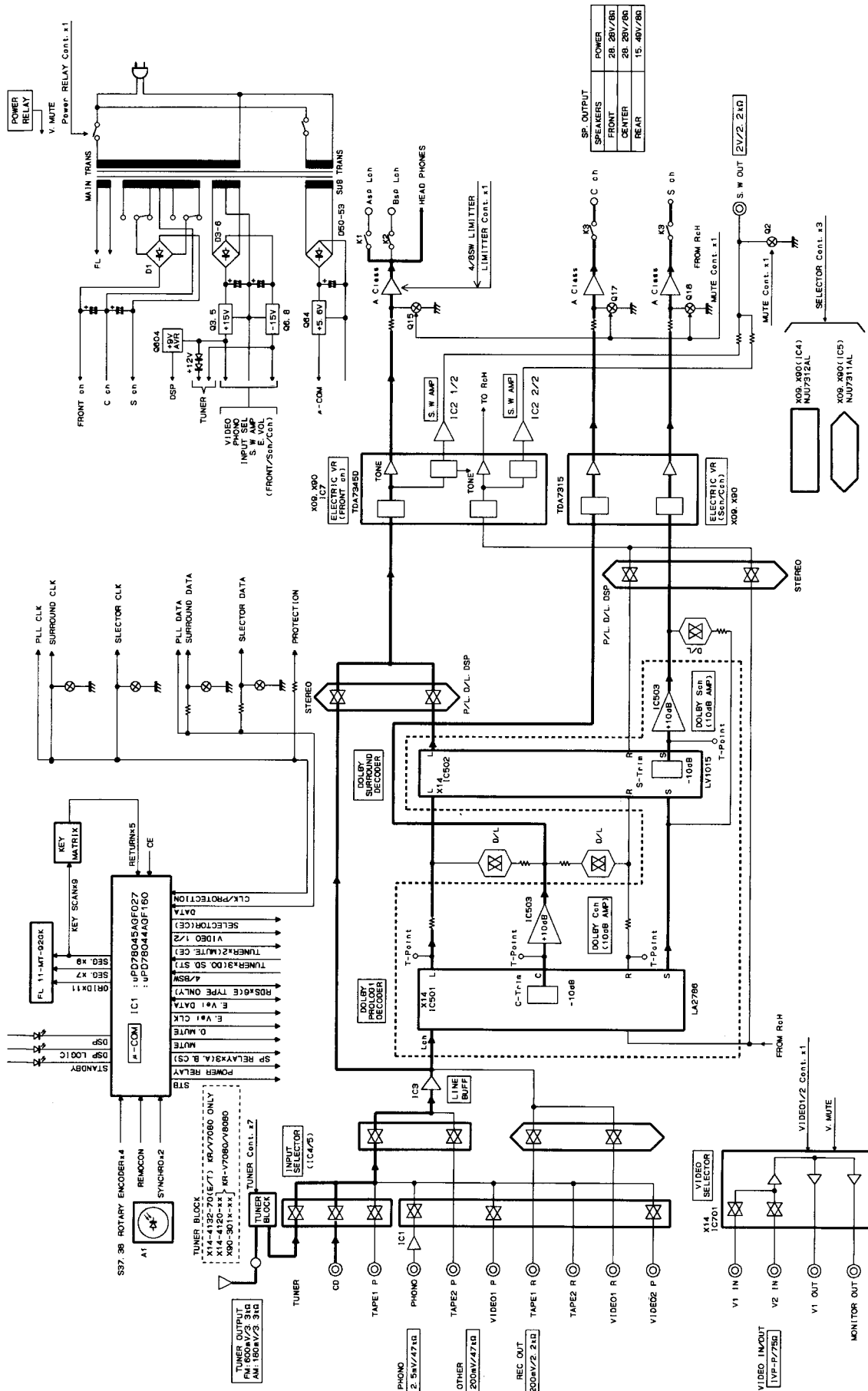

KR-V7080/V8080

KR-V7080/V8080

CIRCUIT DESCRIPTION

1. INITIAL STATE

(1) POWER OFF

(2) AMP-related block

- AUDIO SELECTOR TUNER
- VIDEO SELECTOR VIDEO 1
- SPEAKER A ON
- SPEAKER B OFF
- TAPE 2 MONITOR OFF
- LINE STRAIGHT OFF
- AUDIO ADJUST MODE BALANCE
- BASS 0 dB
- TREBLE 0 dB
- SUB WOOFER 0 step
- BALANCE CENTER
- VOLUME 7 step
- LOUDNESS OFF

(3) SURROUND-related block

- SURROUND MODE STEREO (SURROUND OFF)
- SURROUND ADJUST MODE DELAY
- DELAY TIME
 - DSP/DSP LOGIC 30ms
 - DOLBY PRO LOGIC 20ms
- CENTER LEVEL 0 dB
- REAR LEVEL 0 dB
- CENTER MODE NORMAL
- DSP MODE ARENA
- DSP LOGIC MODE LARGE

(4) Tune-related block

- BAND FM
- FREQUENCY Lower-limit value of FM (87.50 MHz)
- AUTO MODE AUTO
- P.CH DISPLAY -- CH

(5) TEST PRESET FREQUENCY

Channel	BAND	K1 TYPE	BAND	K2 TYPE	BAND	E TYPE
01ch	FM	87.50MHz	FM	87.50MHz	FM	87.50MHz
02ch	FM	98.00MHz	FM	98.00MHz	FM	98.00MHz
03ch	FM	108.00MHz	FM	108.00MHz	FM	108.00MHz
04ch	AM	630kHz	AM	630kHz	AM	630kHz
05ch	AM	1000kHz	AM	1000kHz	AM	999kHz
06ch	AM	1440kHz	AM	1440kHz	AM	1440kHz
07ch	FM	87.50MHz	FM	87.50MHz	FM	87.50MHz
08ch	FM	87.50MHz	FM	87.50MHz	FM	87.50MHz
09ch	FM	87.50MHz	FM	87.50MHz	FM	87.50MHz
10ch	FM	89.10MHz	FM	89.10MHz	FM	89.10MHz
11ch	FM	90.00MHz	FM	90.00MHz	FM	90.00MHz
12ch	FM	97.50MHz	FM	97.50MHz	FM	97.50MHz
13ch	FM	98.50MHz	FM	98.50MHz	FM	98.50MHz
14ch	FM	106.00MHz	FM	106.00MHz	FM	106.00MHz
15ch	AM	530kHz	AM	530kHz	AM	531kHz
16ch	AM	990kHz	AM	990kHz	AM	990kHz
17ch	AM	1700kHz	AM	1610kHz	AM	1602kHz
18ch	FM	87.50 MHz	FM	87.50MHz	FM	87.50MHz
19ch	FM	87.50MHz	FM	87.50MHz	FM	87.50MHz
20ch	FM	87.50MHz	FM	87.50MHz	FM	87.50MHz

The initial setting is performed in a following event :

1. When backup memory data is destroyed when reset is applied to the microprocessor.
2. When the power cord is plugged in to the AC wall outlet while pressing the POWER key.

KR-V7080/V8080

CIRCUIT DESCRIPTION

2. BACKUP

This function holds the current state of the unit even if the AC power of the AV receiver is turned OFF.

(1) Operation outline

The backup state set command signal (CE) of a microcomputer is set low when the AC power is turned OFF. The microcomputer detects the signal and enters the stop state.

The microcomputer is reset when the AC power is turned ON. The data for backup state confirmation is checked by reset processing.

The microcomputer is initialized when the data was destroyed. If it is not destroyed, the microcomputer is started in the backup state.

- The data for backup state confirmation is written in a RAM area.
- The microcomputer is set to the STOP mode so as to save the power consumption.
- A backup state set command signal is detected by a timer interrupt of 1 msec.
- The backup guarantee period is set in a circuit.

(2) Backup state setting

- The data (A596H/5A69H) for backup state confirmation is written in a RAM area.
- Setting the special function port
 - Set the input/output port of a serial interface to the serial interface operation stop mode. Set the FIP controller to the display OFF mode.
- Setting the microcomputer's internal special function
 - Set all the interrupt enable flags to the disable state, respectively. Set the microcomputer to the STOP mode and stop the system clock oscillation of the microcomputer.

(3) Contents of backup data to be held

- POWER ON/OFF state
- VOLUME LEVEL data
- BALANCE LEVEL data
- N.B.ON/OFF
- SELECTOR SOURCE
- TUNER ----
- LAST BAND
- RECEIVING STATION FREQUENCY data
- PRESET MEMORY data (1ch~40ch)
- AUTO/MANUAL mode

---- AMP ----

- POWER STANDBY ON/OFF
- SELECTOR SOURCE
- VIDEO OUT SOURCE
- TAPE2 MONITOR ON/OFF
- SPEAKER A RELAY ON/OFF
- SPEAKER B RELAY ON/OFF
- VOLUME LEVEL VALUE
- AUDIO ADJUST MODE
- BALANCE LEVEL VALUE
- BASS LEVEL
- TREBLE LEVEL
- SUB WOOFER LEVEL
- LINE STRAIGHT ON /OFF
- LOUDNESS ON/OFF

---- SURROUND ----

- SURROUND MODE
- DSP MODE
- DSP LOGIC MODE
- CENTER MODE
- SURROUND ADJUST MODE
- DELAY TIME
- CENTER LEVEL
- REAR LEVEL

3. PROTECTION

The protection state is entered when abnormality is detected during the POWER-ON sequence.

- The power and speaker are turned OFF when the abnormal state is detected during the POWER-ON sequence.
- The STANDBY LED blinks every 500 msec.
- The fluorescent display indicator goes OFF.

KR-V7080/V8080

CIRCUIT DESCRIPTION

4. DESTINATION LIST OF TUNER

Table 4-1 Destination List of Tuner

Destination	BAND	Receive frequency range	channel space	1F	PLL reference frequency	Destination DSW(X14-)		
						DSW2	DSW1	DSW0
						D31	D16	D29
K1	FM	87.5MHz~108.0MHz	100kHz	+10.7MHz	25kHz	0	0	0
	AM	530kHz~1700kHz	10kHz	+450kHz	10kHz			
K2	FM	87.5MHz~108.0MHz	100kHz	+10.7MHz	25kHz	0	0	1
	AM	530kHz~1610kHz	10kHz	+450kHz	10kHz			
E1	FM	87.5MHz~108.0MHz	50kHz	+10.7MHz	25kHz	0	1	1
	AM	531kHz~1602kHz	9kHz	+450kHz	9kHz			
E3 (RDS)	FM	87.5MHz~108.0MHz	50kHz	+10.7MHz	25kHz	1	0	1
	AM	531kHz~1602kHz	9kHz	+450kHz	9kHz			
M	KZ/E1 changes by only setting "DSW1". (DSW 1=0 : K2 Type, 1 : E1 Type)					0	X	1

DIODE SW(DSWX) : 0 = Without DIODE (When static, input LOW)
 1 = With DIODE(When static, input HIGH)
 X = TRANSISTOR SW (0 = OFF 1=ON)

※ ATTENTION

A SUB WOOFER output signal is output irrespective of SP selector switch (ASP and BSP) ON/OFF setting
 The RDS PTY AF search always corresponds to a span search of 100kHz. Therefore, a span search of 50 kHz cannot be performed.

5. TEST MODE

5-1. TEST MODE OF MAIN UNIT

(1) Setting the test mode

The main unit is put into the test mode when the AC power is turned ON while pressing the "TUNING DOWN" key. The following state is obtained when the test mode of the main unit set.

- The power is turned ON automatically.
- All the fluorescent display indicators and LEDs light.
(The all-illuminated state is cleared by pressing any main unit key.)
- The backup state except when the power is turned ON and OFF is initialized.

(2) Canceling the test mode

Turn OFF the AC power.

(3) Tuner functions

- Preset channel call function
 - 1) Calls channels 1 to 9 (keys 1 to 9) and channel 10 (key 0) when the 10 key is not operated.
 - 2) Calls channels 11 to 19 (keys 1 to 9) and channel 20 (key 0) when the +10 key is operated once.
 - 3) Calls channels 21 to 29 (keys 1 to 9) and channel 30 (key 0) when the +10 key is operated two times and calls channels 31 to 39 (keys 1 to 9) and channel 40 (key 0) when the +10 key is operated three times.

- 4) Shifts to the operation obtained when the +10 key is not operated if it is operated four times.
- S level hexadecimal data display function
 With the selector on TUNER, when the "DOLBY PRO LOGIC" key on the main unit is operated, the frequency display ceases and the S level is displayed in hexadecimal while the key is pressed.
 When "3 STEREO" is operated, the display is switched to restore the normal display.
 - Mute signal output
 No Selector MUTE(MUTE 1) control regulation is done whatever.
 - With the selector on TUNER, when the "SP A" key on the main unit is operated, the SP A display is erased and ATT is on. If the "SP A" on the main unit is operated again after that, SP A is displayed and ATT is switched OFF. The SP A operation and ATT operation work together and are combined with switching the ATT display ON and OFF.

※ Under the ATT ON/OFF relationship, ATT can not be entered in an AF search in test mode.
 The ATT operation is done from ATT OFF.
 If SP A was turned OFF with the selector on something other than TUNER, it will come on when TUNER is selected.

KR-V7080/V8080

CIRCUIT DESCRIPTION

(4) AMP function

The original function of each key is executed when the SELECTOR mode is set to TUNER. The test mode operation is not performed in this case.

- One touch max, mid, min setting for Audio Level and Surround Level

The variation of Audio Level and Surround Level can be operated by turning the Multi-Level UP or DOWN and, if the selector is on something other than TUNER, max, mid, min settings can be made with the number keys.

- 1) Max is number key "2"
- 2) Mid is number key "3"
- 3) Min is number key "1"
- 4) The Mid setting is as follows:

Master VOL. DELAY is the initial value

Balance is centered

BASS, TREBLE, SUB-WOOFER, CENTER and REAR are 0 dB or 0 step

Effect is 1 step

(5) EFFECT is 0 step for Min and 2 step for Max.

- One touch settings for Audio Level and Surround Level items

The variation of Audio Level and Surround Level items can be set with respective keys and, if the selector is on something other than TUNER, direct settings can be made with the number keys.

- 1) Balance is number key "4"
- 2) Bass is number key "5"
- 3) Treble is number key "6"
- 4) Sub-Woofer is number key "7"
- 5) Rear Level is number key "8"
- 6) Center Level is number key "9"
- 7) Delay Time is number key "0"
- 8) Effect Level is number key "+10"

- TEST TONE operation

Uses the "DIRECT" key instead of the "TEST TONE" key.

- MUTE signal output

Sets the analog muting to OFF at all times. No control is performed in this case. Sets the analog muting to ON in the same way as during normal operation when the front volume is set to the minimum value(-∞ dB).

- Impedance 4/8 selection

No impedance 4/8 display appears in the normal state. Therefore, the SPEAKERS lamp of the fluorescent display indicator is turned ON and OFF in the test mode.

The SPEAKERS lamp is turned ON when the impedance is 4.

The SPEAKERS lamp is turned OFF when the impedance is 8.

- MUTE Operation

Mute operation is toggled ON and OFF by pressing the "AUTO/MANUAL" key.

5-2. SERIAL TEST MODE

(1) Setting the serial test mode

The unit is put into the serial test mode when a serial code "TEST ON" is input during the POWER-ON sequence.

In the 8-bit serial test mode, serial code 71H is input.

In the 16-bit serial test mode, serial code C27FH is input.

- In the serial test mode, all remote control keys and ordinary serial codes are disabled. Only the panel keys perform the same operation as usually.

(2) Canceling the serial test mode

- The serial test mode is canceled to return to the ordinary mode by inputting a "TEST OFF" code. After the ordinary mode was returned, the serial mode is returned to the state before the test mode is entered. The backup operation is not initialized.
- The serial test mode is also canceled when the AC power is turned OFF.

(3) Cautions

- The serial test code is prescribed as a 16-bit code only.
- The operations below are inhibited in the serial test mode.
 - Manual tuning UP/DOWN operation
 - UP/DOWN selection in PTY selection mode
 - AF search in ATT ON state
 The operations mentioned above cannot be guaranteed when they are performed in the serial test mode.
- An identical code is output when the serial test mode code is input.
- A TUNED ON/TUNED OFF code is only output.

(4) The serial test mode codes for ATT ON/OFF operate in the same way as for test mode with the main unit keys.

(SP A also goes ON/OFF as ATT goes on/off.)

- Under the ATT ON/OFF relationship, ATT can not be entered in an AF search in test mode.

The ATT operation is done from ATT OFF.

If SP A was turned OFF with the selector on something other than TUNER, it will come on when TUNER is selected.

KR-V7080/V8080

CIRCUIT DESCRIPTION

(5) SERIAL TEST CODE LIST (C2XXH)

TYPE FUNC	AMP							TUNER								
	0	1	2	3	4	5	6	7	8	9	A	B	C	D	E	F
0	POWER OFF	CD DIRECT OFF	SP B OFF	DUAL SOUND LEVEL1	NB OFF					POWER OFF	0	MEMORY (ENTER)				
1	POWER ON	CD DIRECT ON	SP B ON	DUAL SOUND LEVEL2	OMNI SP ON	FRONT SP ON				POWER ON	1	MAIN				
2	PHONO	CD REC OFF	HIT MASTER OFF	DUAL SOUND LEVEL3	MUTING (-30dB) OFF	FRONT SP OFF				MUTE OFF	2	SUB				
3	CD	CD REC ON	HIT MASTER ON	DUAL SOUND INPUT CD	MUTING (-30dB) ON	C/S SP ON				MUTE ON	3	BOTH				
4	TUNER	SOURCE DIRECT OFF	MOTOR VOL UP	DUAL SOUND INPUT TUNER	NB LEVEL1	C/S SP OFF				AUTO STEREO	4	AF				
5	TAPE (TAPE A)	SOURCE DIRECT ON	MOTOR VOL DOWN	DUAL SOUND INPUT TAPE	NB LEVEL2	C/S MUTE ON				MONO	5	PTY				
6	TAPE2 (TAPE B)	LINE STRAIGHT OFF	MOTOR VOL STOP	DUAL SOUND INPUT MD/DAT	NB LEVEL3	VIDEO5				TUNED OFF	6	DISPLAY				
7	AUX	SINE STRAIGHT ON	DBS/TV	DUAL SOUND INPUT VIDEO	BALANCE Lch MAX	MENU				TUNED ON	7					
8	DAT	LOUDNESS OFF	TAPE2 MONITOR OFF	DUAL SOUND INPUT AV/AUX	BALANCE Lch/Rch CENTER	tone CONTROL OFF				ACTIVE RECEPTION OFF	8					
9	VIDEO1 (VIDEO)	LOUDNESS ON	TAPE2 MONITOR ON	BGM OFF	BALANCE Rch MAX	tone CONTROL ON		FL ALL OFF OFF		ACTIVE RECEPTION ON	9					FL ALL OFF OFF
A	VIDEO2	SUB SONIC OFF	VIDEO MUTE ON	BGM ON	L.A.C. MAIN MAX	BASS MIN		FL ALL OFF ON		RF DIRECT	+10					FL ALL OFF ON
B	VIDEO3	SUB SONIC ON	LAC VOL UP	FAN OFF	L.A.C. MAINSUB CENTER	BASS MID		ALL ON OFF		ATT ON	BAND FM					ALL ON OFF
C	VIDEO4 (VDP)	SUPER WOOFER OFF	LAC VOL DOWN	FAN ON	L.A.C. SUB MIN	BASS MIX		ALL ON ON		ATT OFF	BAND AMMW					ALL ON ON
D	MUTE ON (MAIN)	SUPER WOOFER ON	LAC VOL STOP	FAN SPEED LOW	FAN STOP LOW	TREBLE MIN		AMP INITIAL		IF NORMAL	BAND TVLW					TUNER SERIAL TEST OFF
E	SEL MUTE ON	SPEAKER A OFF (FRONT)	DUAL SOUND OFF	FAN SPEED HIGH	FAN STOP HIGH	TREBLE MID		AMP SERIAL TEST OFF		IF NARROW	DOWN					TUNER SERIAL TEST OFF
F	MUTE ALL OFF	SPEAKER A ON (FRONT)	DUAL SOUND ON	NB ON		TREBLE MAX		AMP SERIAL TEST ON		DIRECT	UP					TUNER SERIAL TEST ON

□ : Sending code ■ : Receiving code

(C3XXH)

TYPE FUNC	SURROUND							GE								
	0	1	2	3	4	5	6	7	8	9	A	B	C	D	E	F
0	POWER OFF	REAR MUTE ON	ASFC MAX	ACOUSTIC BGM	PRESENCE GAME	ECHO 2	SUB WOOFER LEVEL MIN			POWER OFF	EQ JAZZ					
1	POWER ON	MUTE ALL OFF	SEAT POS MIN	CINEMA SCREEN OFF	PRESENCE KARAOKE	PRESENCE HIT MASTER	SUB WOOFER LEVEL MID			POWER ON	EQ FUSION					
2	STEREO BYPASS/OFF	CENTER LEVEL MIN	SEAT POS MID	CINEMA SCREEN 1	F.2ch	THX	SUB WOOFER LEVEL MAX			MUTE OFF	EQ MOVIE					
3	DOLBY SURROUND NORMAL/WID	CENTER LEVEL MID	SEAT POS MAX	CINEMA SCREEN 2	DOLBY SURROUND (PHANTOM)	MONO				MUTE ON						
4	DOLBY 3 STEREO	CENTER LEVEL MAX	WALL MIN	CINEMA SCREEN 3	DEPTH OFF	INPUT LEVEL MIN				EQ OFF						
5	DSP	REAR R LEVEL MIN	WALL MID	CH MODE 2ch	DEPTH ON	INPUT LEVEL MID				EQ ON						
6	DSP LOGIC	REAR R LEVEL MID	WALL MAX	CH MODE 3ch	DEPTH MODE VOCAL	INPUT LEVEL MAX				M1 (ALL CEN)						
7	S 4ch	REAR R LEVEL MAX	ROOM SIZE MIN	CH MODE 4ch	DEPTH MODE INSTRUMENT	FRONT L LEVEL MIN				M2 (ALL MAX)						
8	F 4ch	DELAY TIME MIN	ROOM SIZE MID	CH MODE 5ch	DEPTH LEVEL MIN	FRONT L LEVEL MID				M3 (ALL MIN)						
9	CENTER MODE NORMAL	DELAY TIME MID	ROOM SIZE MAX	DSP THROUGH	DEPTH LEVEL MID	FRONT L LEVEL MAX		FL ALL OFF OFF		EEPROM TEST						FL ALL OFF OFF
A	CENTER MODE WIDE	DELAY TIME MAX	STEREO (KARAOKE)	DSP ARENA	DEPTH LEVEL MAX	FRONT R LEVEL MIN		FL ALL OFF ON		EEPROM TEST OK						FL ALL OFF ON
B	CENTER MODE PHANTOM	(PRESENCE) EFFECT LEVEL MIN	MULTI (KARAOKE)	DSP JAZZ CLUB	SUB(OMNI) MUTE ON	FRONT R LEVEL MID		ALL ON OFF		EEPROM TESTING						ALL ON OFF
C	TEST TONE OFF	(PRESENCE) EFFECT LEVEL MID	HIFI MULTI (KARAOKE)	DSP STADIUM	DSP LOGIC LARGE	FRONT R LEVEL MAX		ALL ON ON		LINE ON						ALL ON ON
D	TEST TONE ON	(PRESENCE) EFFECT LEVEL MAX	(NORMAL) (KARAOKE)	PRESENCE DISCO THEQUE	DSP LOGIC SMALL	REAR L LEVEL MIN		SURROUND INITIAL		TAPE ON						GE INITIAL
E	FRONT MUTE ON	ASFC MIN	ACOUSTIC NON DIRE1	PRESENCE CHURCH	ECHO OFF	REAR L LEVEL MID		SURROUND SERIAL TEST OFF		EQ POP						GE SERIAL TEST OFF
F	CENTER MUTE ON	ASFC MID	ACOUSTIC NON DIRE2	PRESENCE MOVIE	ECHO 1	REAR L LEVEL MAX		SURROUND SERIAL TEST ON		EQ ROCK						GE SERIAL TEST ON

□ : Sending code ■ : Receiving code

KR-V7080/V8080

CIRCUIT DESCRIPTION

(C4XXH)

H L	VOLUME LEVEL															
	0	1	2	3	4	5	6	7	8	9	A	B	C	D	E	F
0	VOLUME 0	VOLUME 16	VOLUME 32	VOLUME 48	VOLUME 64											
1	VOLUME 1	VOLUME 17	VOLUME 33	VOLUME 49	VOLUME 65											
2	VOLUME 2	VOLUME 18	VOLUME 34	VOLUME 50	VOLUME 66											
3	VOLUME 3	VOLUME 19	VOLUME 35	VOLUME 51	VOLUME 67											
4	VOLUME 4	VOLUME 20	VOLUME 36	VOLUME 52	VOLUME 68											
5	VOLUME 5	VOLUME 21	VOLUME 37	VOLUME 53	VOLUME 69											
6	VOLUME 6	VOLUME 22	VOLUME 38	VOLUME 54	VOLUME 70											
7	VOLUME 7	VOLUME 23	VOLUME 39	VOLUME 55	VOLUME 71											
8	VOLUME 8	VOLUME 24	VOLUME 40	VOLUME 56	VOLUME 72											
9	VOLUME 9	VOLUME 25	VOLUME 41	VOLUME 57	VOLUME 73											
A	VOLUME 10	VOLUME 26	VOLUME 42	VOLUME 58	VOLUME 74											
B	VOLUME 11	VOLUME 27	VOLUME 43	VOLUME 59	VOLUME 75											
C	VOLUME 12	VOLUME 28	VOLUME 44	VOLUME 60	VOLUME 76											
D	VOLUME 13	VOLUME 29	VOLUME 45	VOLUME 61	VOLUME 77											
E	VOLUME 14	VOLUME 30	VOLUME 46	VOLUME 62	VOLUME 78											
F	VOLUME 15	VOLUME 31	VOLUME 47	VOLUME 63												

◻ : Sending code ◼ : Receiving code

KR-V7080/V8080

CIRCUIT DESCRIPTION

6. Microprocessor : μ PD78044AGF160 (X14 : IC1)
 μ PD78045AGF027

Block diagram

μ PD78044AGF160 [K, P, M, X, Y, type]

μ PD78045AGF027 [E, T type]

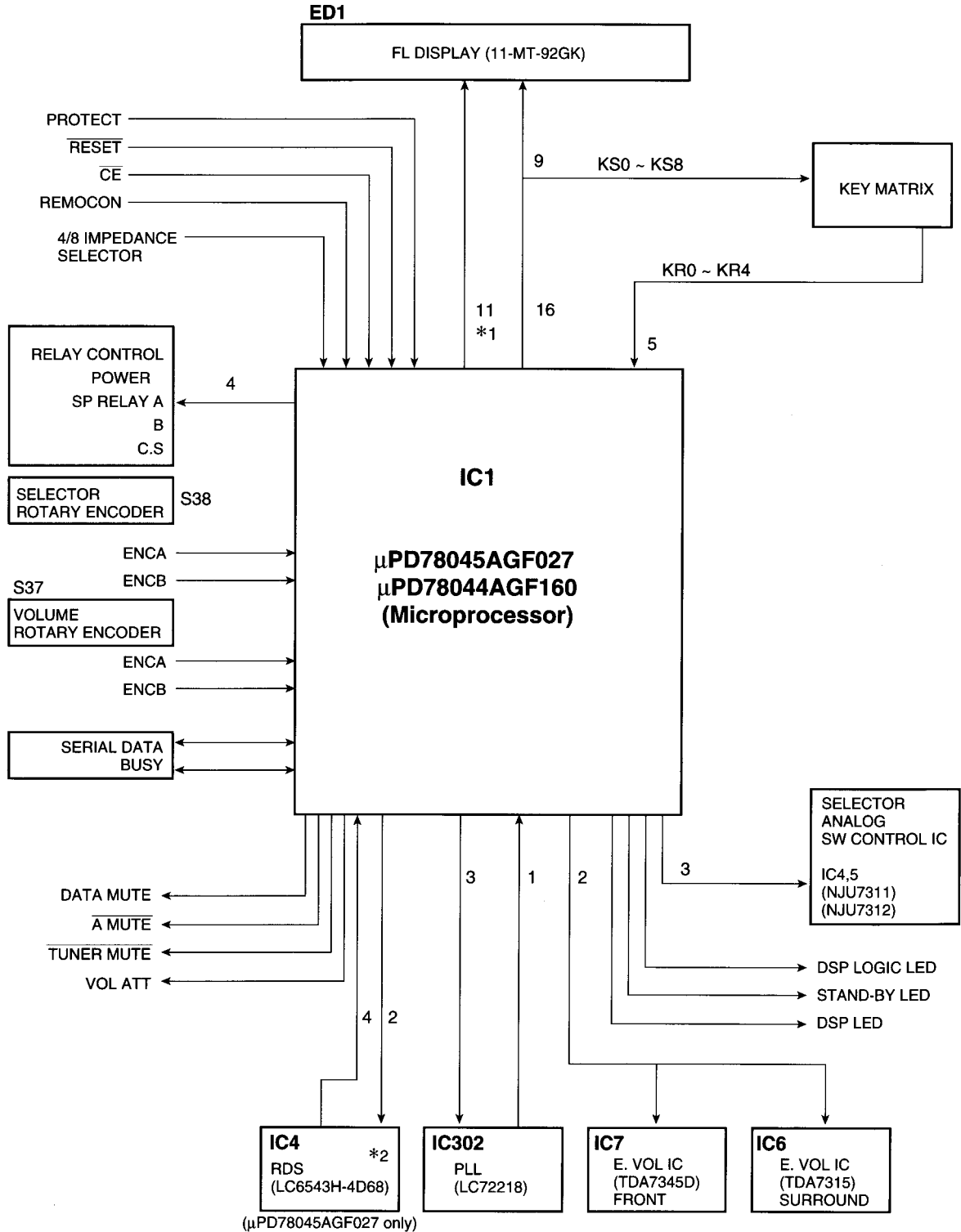

(μ PD78045AGF027 only)

*1 GRID to FL

*2 E3 Type (RDS feature installed) used RDS cynic microprocessor (LC6543H-4D68).

KR-V7080/V8080

CIRCUIT DESCRIPTION

6-1. PIN FUNCTION

Pin NO.	Pin name	Port I/O	Name	Description	Active
1	P94/FIP6	O	5G	FL grid 5	————
2	P93/FIP5	O	6G	FL grid 6	————
3	P92/FIP4	O	7G	FL grid 7	————
4	P91/FIP3	O	8G	FL grid 8	————
5	P90/FIP2	O	9G	FL grid 9	————
6	P81/FIP1	O	10G	FL grid 10	————
7	P80/FIP0	O	11G	FL grid 11	————
8	Vcc	—	VDD	Micro processor power supply	————
9	P27/SCK0	I/O	PROTECT/CLK	IN : Protection detection OUT : Control IC clock	H : ON
10	P26/S00/SBI	—	DATA	OUT : PLL IC/Selector IC/Surround IC control data	————
11	P25/S10/SB0	O	SUR ST.	Surround IC strobe	H : NORMAL L : TRANSFER
12	P24/BUSY	O	SEL ST.	Selector IC strobe	H : NORMAL L : TRANSFER
13	P23/STB	O	POWER RELAY	Power relay control	H : ON
14	P22/SCK1	O	SP B RELAY	Speaker B relay control	H : ON L : OFF
15	P21/S01	O	SP A RELAY	Speaker A relay control	H : ON L : OFF
16	P20/SI1	O	SP CS RELAY	Surround speaker relay control	H : ON L : OFF
17	RESET	I	RESET	Microprocessor reset	L : RESET ON
18	P74	I	4/8 SELECT	IN : Speaker impedance selector	H : 4Ω L : 8Ω
19	P73	I	CE	AC OFF(MAIN POWER) detection Signal	L : AC OFF
20	AVSS	—	AVSS	A/D power SUPPLY (GND)	————
21	P73/P17/AN17	O	A MUTE	Volume IC address/data CE Analog mute signal	L : ON
22	P16/AN16	O	TUNER MUTE	Tuner mute control	L : MUTE ON
23	P15/AN15	I	STEREO	Stereo signal detection	L : STEREO ON
24	P14/AN14	I	SD	Synchronized signal detection	————
25	P13/AN13	I	DO	IF count data (PLL DO)	————
26	P12/AN12	O	CE(PLL)	PLL Chip enable control	————
※27	P11/AN11	O	ATT (RDS)	Attenuate control	H : ON
※28	P10/AN10	I	S.LEVEL (RDS)	Signal level	H : ON
29	A Vcc	—	VDD	A/D power supply	————
30	A Vref	—	+5V	A/D reference voltage	————
31	P04/XT1	I	VOLUME ENCB	Volume encoder input B	————
32	XT2	—	NC		————
33	Vss	—	Vss	Microprocessor power supply	————
34	X1	—	OSC	4.19MHz oscillator	————
35	X2	—	OSC	4.19MHz oscillator	————
36	P37	I	VOLUME ENCA	Volume encoder in put A	————
37	P36/BUZ	O	SDA	Electric volume IC control data	————
38	P35/PCL	O	SCL	Electric volume IC control clock	————
39	P34/T12	I	SELECTOR ENCB	Selector encoder input B	————
40	P33/T11	I	SELECTOR ENCA	Selector encoder input A	————
41	P32/T02	I/O	S.DATA	8/16 bit system data	————
42	P31/T01	I/O	S.BUSY	8/16 bit system busy	H : BUSY L : READY
※43	P30/T00	O	RES (RDS)	RDS IC reset signal	L : RESET ON
※44	P03/INTP3/C10	I	CLK (RDS)	RDS clock	————

※E/T type only, other types unused.

KR-V7080/V8080

CIRCUIT DESCRIPTION

Pin NO.	Pin name	Port I/O	Name	Description	Active
※45	P02/INTP2	I	DATA(RDS)	RDS data	_____
※46	P01/INTP1	I	START(RDS)	RDS data start signal	L : START
47	P00/INTP0/TI	I	REM	Remote control input	_____
48	IC	—	Vss		_____
49	P72	O	STANDBY LED	Standby LED	L : LED ON
50	P71	O	DSP LOGIC LED	DSP LOGIC LED	L : LED ON
51	P70	O	DSP LED	DSP LED	L : LED ON
52	VDD	—	VDD	Microprocessor power supply (+5V)	_____
53	P127/FIP33	O	VOL ATT	Volume(-12.5dB) attenuate signal	H : ATT ON L : ATT OFF
54	P126/FIP32	O	DATA MUTE	Data mute control	H : ON
55	P125/FIP31	I	KR4	Key return 4	_____
56	P124/FIP30	I	KR3	Key return 3	_____
57	P123/FIP29	I	KR2	Key return 2	_____
58	P122/FIP28	I	KR1	Key return 1	_____
59	P121/FIP27	I	KR0	Key return 0	_____
60	P120/FIP26	O	P16KS8	FL Segment 16/key scan 8	_____
61	P117/FIP25	O	P15/KS7	FL Segment 15/key scan 7	_____
62	P116/FIP24	O	P14/KS6	FL Segment 14/key scan 6	_____
63	P115/FIP23	O	P13/KS5	FL Segment 13/key scan 5	_____
64	P114/FIP22	O	P12/KS4	FL Segment 12/key scan 4	_____
65	P113/FIP21	O	P11/KS3	FL Segment 11/key scan 3	_____
66	P112/FIP20	O	P10/KS2	FL Segment 10/key scan 2	_____
67	P111/FIP19	O	P9/KS1	FL Segment 09/key scan 1	_____
68	P110/FIP18	O	P8/KS0	FL Segment 08/key scan 0	_____
69	P107/FIP17	O	P1	FL Segment 1	_____
70	P106/FIP16	O	P2	FL Segment 2	_____
71	V load	—	V load	FL drive power supply (-30V)	_____
72	P105/FIP15	O	P3	FL Segment 3	_____
73	P104/FIP14	O	P4	FL Segment 4	_____
74	P103/FIP13	O	P5	FL Segment 5	_____
75	P102/FIP12	O	P6	FL Segment 6	_____
76	P101/FIP11	O	P7	FL Segment 7	_____
77	P100/FIP10	O	G1	FL grid 1	_____
78	P97/FIP9	O	G2	FL grid 2	_____
79	P96/FIP8	O	G3	FL grid 3	_____
80	P95/FIP7	O	G4	FL grid 4	_____

※The RDS PTY AF search always corresponds to a span search of 100kHz. Therefore, a span search of 50 kHz cannot be performed.

KR-V7080/V8080

CIRCUIT DESCRIPTION

7. KEY MATRIX

[() : μ -com IC port]

Table 7-1 Key Matrix List

KRTN KSCN	KR0 (59)	KR1 (58)	KR2 (57)	KR3 (56)	KR4 (55)
KS0 (68)	—	*1 RDS PTY	*1 RDS AF	*1 RDS DISPLAY	—
KS1 (67)	6 (10KEY)	5 (10KEY)	—	LOUDNESS	TAPE 2
KS2 (66)	7 (10KEY)	4 (10KEY)	—	MEMORY	LINE STRAIGHT
KS3 (65)	8 (10KEY)	3 (10KEY)	+10	DIRECT	AUDIO LEVEL MODE
KS4 (64)	9 (10KEY)	2 (10KEY)	REMOTE POWER	AUTO	SURROUND LEVEL MODE
KS5 (63)	0 (10KEY)	1 (10KEY)	SPEAKER A	SPEAKER B	MULTI DOWN
KS6 (62)	PRO LOGIC	DSP LOGIC	STEREO	TUNING DOWN	MULTI UP
KS7 (61)	3 STEREO	DSP	BAND	TUNING UP	CENTER MODE
KS8 (60)	* 3 DSW0	* 3 DSW1	* 3 DSW2	* 2 DSW3	—

* 1 The destination is E3 type only. For another destination, there is no key. (RDS function)

* 2 Used for operation selector of 8- or 16- bit serial data.

* 3 Used for discrimination of the destination. (Refer to the Destination List of Tuner in Table 5-1.)

8. XS8/XL16 Function

Implements an additional operation by the system in order to shift a system operated by XS8 to SL16.

8-1. Addition of a selector source

Adding a system operation adds selector sources MD and LD and controls MD and LD system operation.

(1) Selector source switching

MD and LD are switched as TAPE1 and VIDEO2 background modes separately from the normal selector functions.

- Switch the selector source by holding down the AUTO panel key for at least two seconds.

TAPE1 -> MD

VIDEO2 -> LD

(If another key is entered while the key is being entered, the key input is set to off and the key is made ineffective.)

When a MD or LD is used, the MD is connected to the RCA Pin of TAPE1 and the LD to the RCA Pin/Video Input of VIDEO2.

- The operation of the system controls only the currently selected source and has no control whatsoever over the operation of the side which is not selected.

For example, while MD is selected, even if the "Deck B Play" serial code is received, MD will remain selected without switching from MD to TAPE1.

(2) Settings during microprocessor backup or initialization

- During microprocessor initialization the selector is set to TAPE1 and VIDEO2. The current selector mode (TAPE1/MD and VIDEO2/LD) is maintained except when the backup is disrupted.

(3) Other items be noted

- This selector switching function has been developed in accordance with new serial codes. Therefore, if XS8 is used, since there is no code for MD and LD, the selector

source function will not work if the 8/16-bit serial mode is 8-bit. It works only in 16-bit mode.

Also, if serial mode has been switched from 16-bit to 8-bit when MD and LD are being selected, it will force a switch to TAPE1 and VIDEO2.

8-2. Changeover preference order

- Pressing KEY, then turn on power.



- Backup data of ①.



- Diode matrix changeover.

8-3. XS8 / SL16 Selection

- KS8 and KR3 are used for the operation selection of 8- or 16- bit serial data. The 8- and 16- bit serial data are selected only during reset initialization.

Table 8-1 8-/16- bit Selection

Serial cord	DSW	DSW3
8- bit serial		0
16- bit serial		1

9. System operation of SL16

Easy operation one way amplifier and receiver. Other source devices are compatible with one-way and two-way easy operation. Operation is 16-bit.

Operation is two way and compatible with operating mode display. Also, adding MD and LD to input selector makes it compatible with easy operation. Apart from TUNER, source devices are operating mode display compatible and input selector MD and LD compatible. Since it is not possible for the amplifier and receiver to be always compatible with operating mode displays, they are only input selector MD and LD compatible and SL16 compatible.

KR-V7080/V8080

ADJUSTMENT

FM SECTION SELECTION : FM
KR-V7080 (E,T TYPE)

NO.	ITEM	INPUT SETTINGS	OUTPUT SETTINGS	TUNER SETTINGS	ALIGNMENT POINTS	ALIGN FOR	FIG.
1	DISCRIMINATOR	(A) 98.0kHz 1kHz, ±40kHz dev. (E,T type) 60 dBμ (ANT input)	Connect a DC voltmeter between TP3 and TP4 (X14-) (B/6)	MONO 98.0MHz	L 303 (X14-) (B/6)	0V	(a)
2	DISTORTION (STEREO)	(C) 98.0MHz 1kHz, ±40kHz dev. Pilot: ±6kHz dev. 60dBμ (ANT input)	(B)	AUTO 98.0MHz	A301 (X14-) (B/6)	Minimum distortion.	(a)

KR-V7080 (OTHER TYPE) / KR-V8080

NO.	ITEM	INPUT SETTINGS	OUTPUT SETTINGS	TUNER SETTINGS	ALIGNMENT POINTS	ALIGN FOR	FIG.
1	DISTORTION (STEREO)	(C) 98.0MHz 1kHz, ±67.5 kHz dev. Pilot: ±7.5kHz dev. 60dBμ (ANT input)	(B)	AUTO 98.0MHz	A301 (X14-) (B/6)	Minimum distortion.	(a)

AUDIO SECTION

NO.	ITEM	INPUT SETTINGS	OUTPUT SETTINGS	TUNER SETTINGS	ALIGNMENT POINTS	ALIGN FOR	FIG.
POWER: ON SPEAKER: B SELECTOR: PHONO							
1	IDLE CURRENT		(E) Connect a DC voltmeter across CP1(L) CP2(R) CP3(CENTER) CP4(REAR) (X09-) (A/4)	Volume: 0	VR1(L) VR2(R) VR3(CENTER) VR4(REAR) (X09-) (A/4)	20mV	(b)

(a)

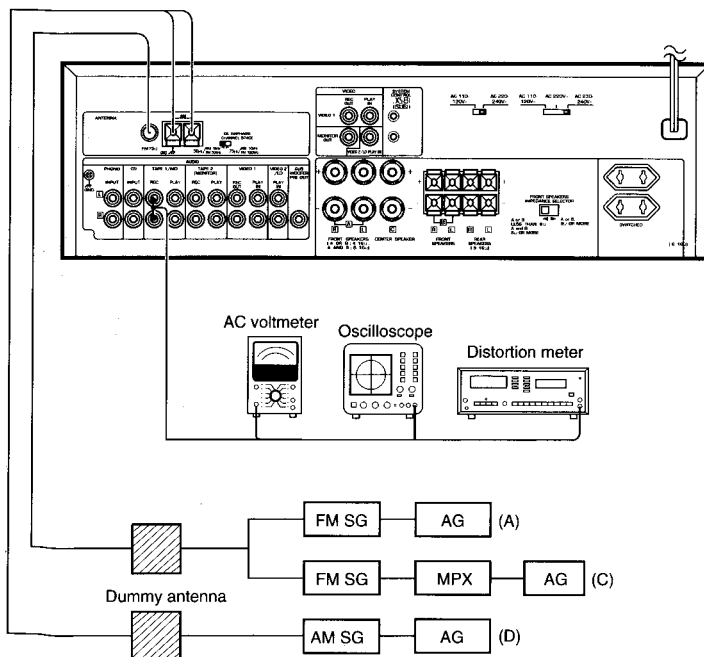

(b)

System connections

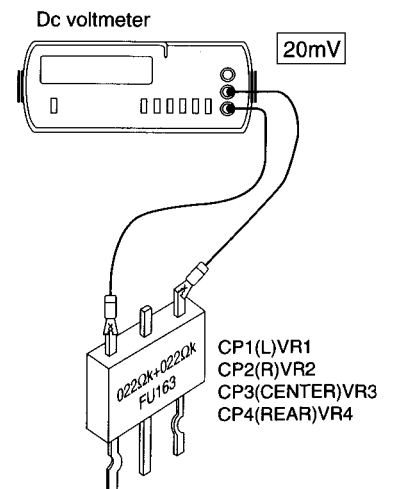

KR-V7080/V8080

WIRING DIAGRAM

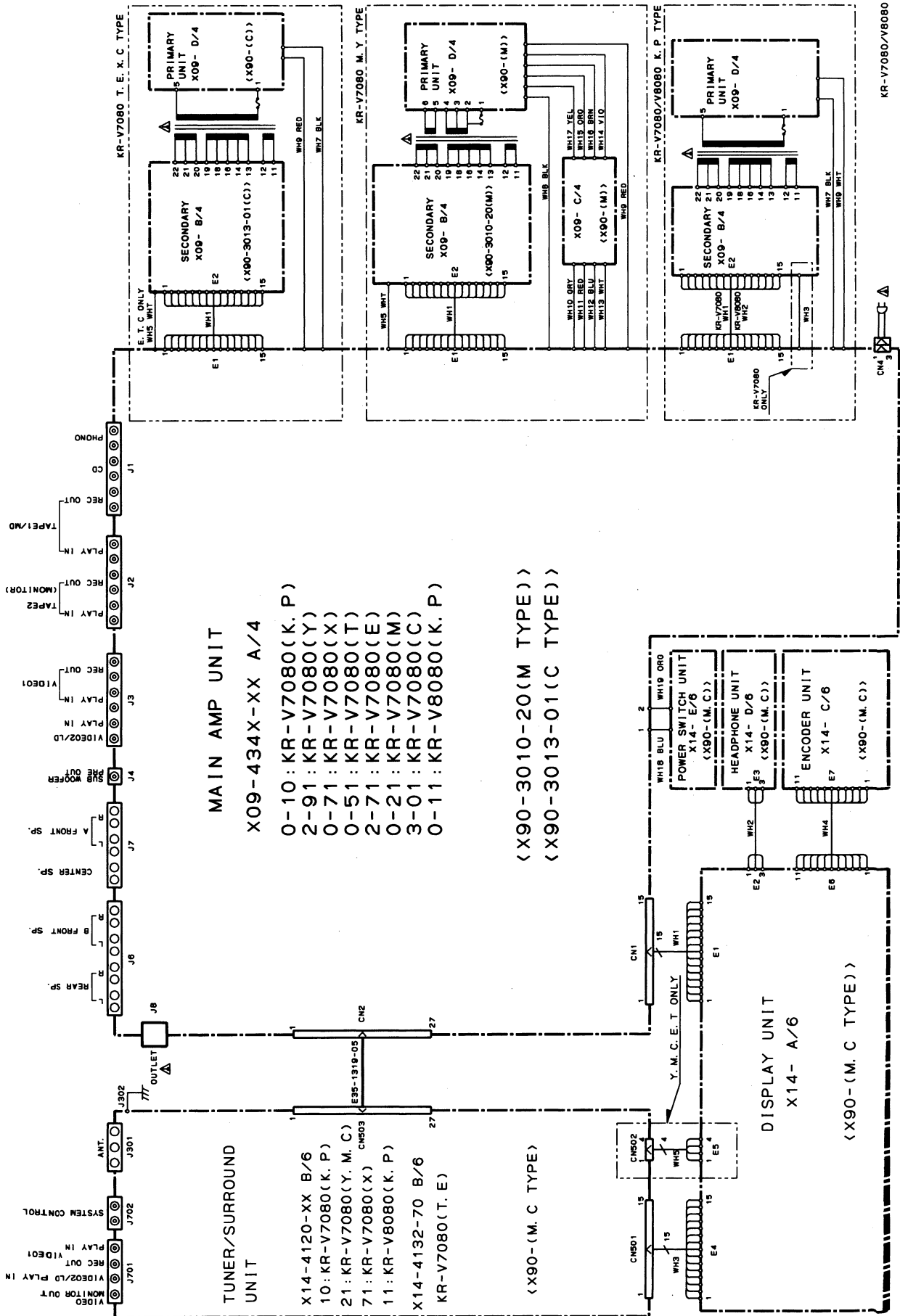

PC BOARD (Component side view)

- DISPLAY unit (X14-41xx-xx)
- 20-10 : KR-V7080 K,P
 - 20-21 : KR-V7080 Y,M,C
 - 20-71 : KR-V7080 X
 - 32-70 : KR-V7080 T,E
 - 20-11 : KR-V8080 K,P

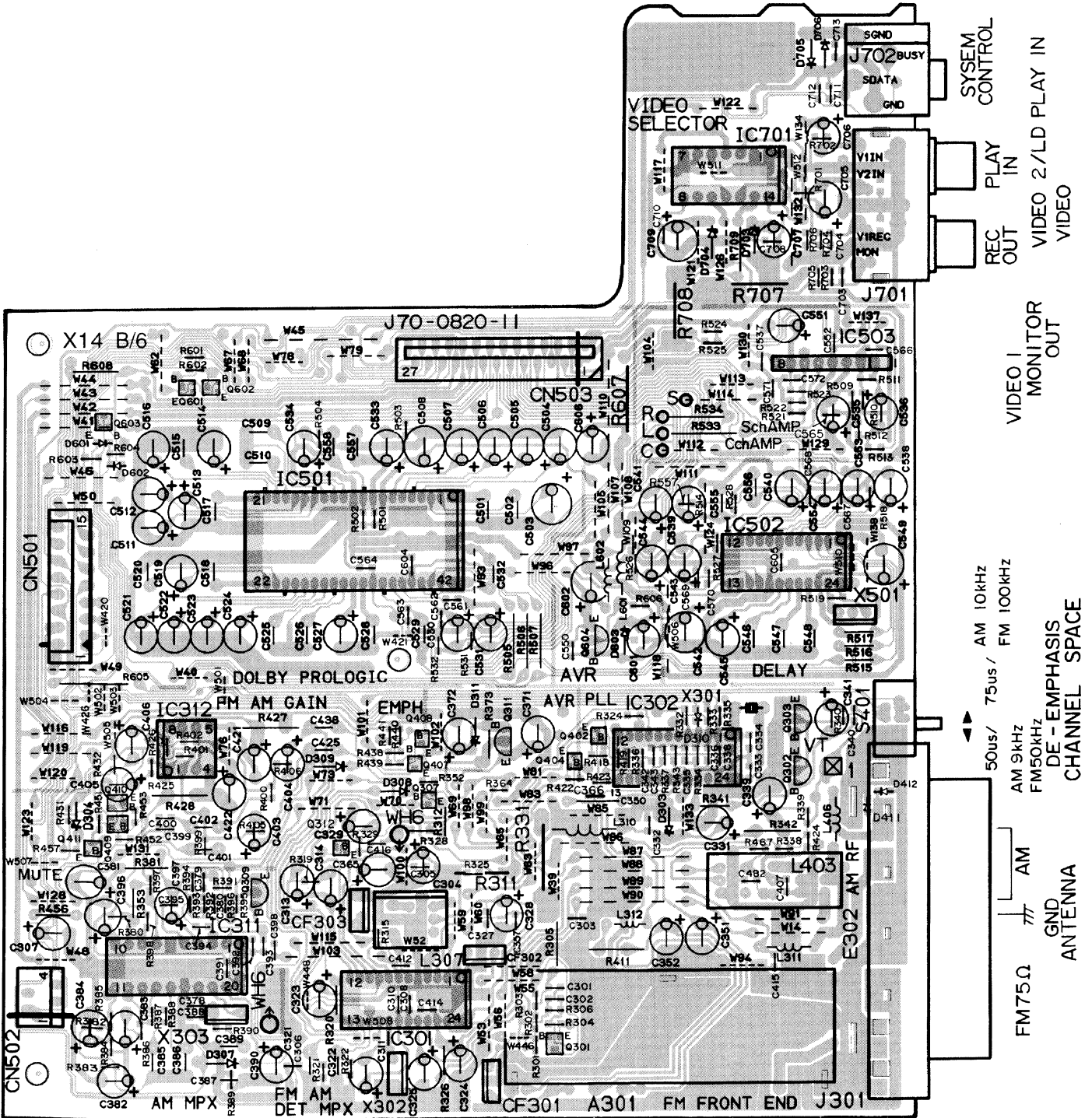

Refer to the schematic diagram for the values of resistors and capacitors.

PC BOARD (Component side view)

DISPLAY unit (X14-41xx-xx) 20-10 : KR-V7080 K,P 20-21 : KR-V7080 Y,M,C 20-71 : KR-V7080 X
 32-70 : KR-V7080 T,E 20-11 : KR-V8080 K,P

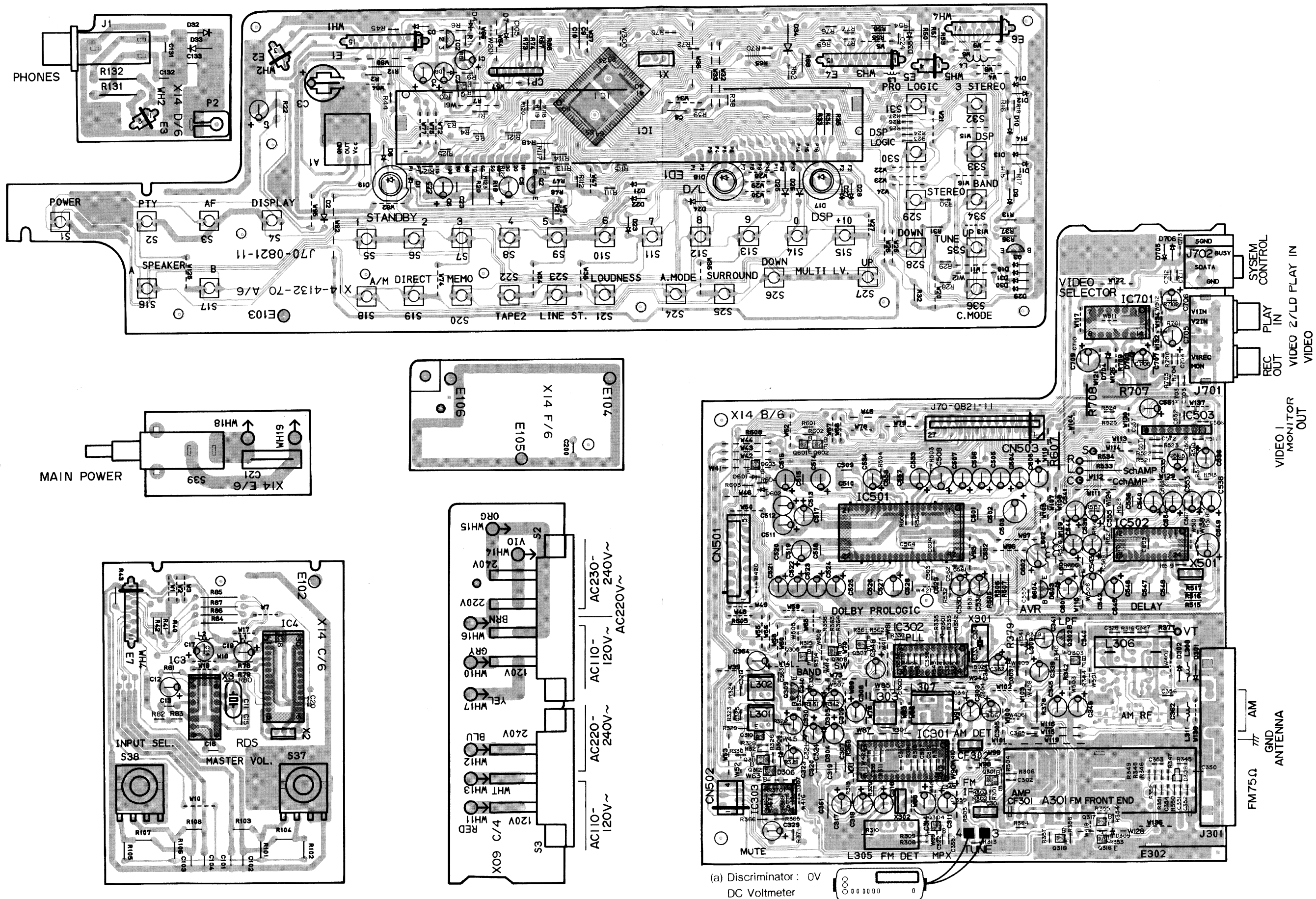

Refer to the schematic diagram for the values of resistors and capacitors.

PC BOARD (Component side view)

AUDIO unit (X09-434x-xx) 0-10 : KR-V7080 K,P
2-71 : KR-V7080 E

0-21 : KR-V7080 M
2-91 : KR-V7080 Y

0-51 : KR-V7080 T
3-01 : KR-V7080 C

0-71 : KR-V7080 X
0-11 : KR-V8080 K,P

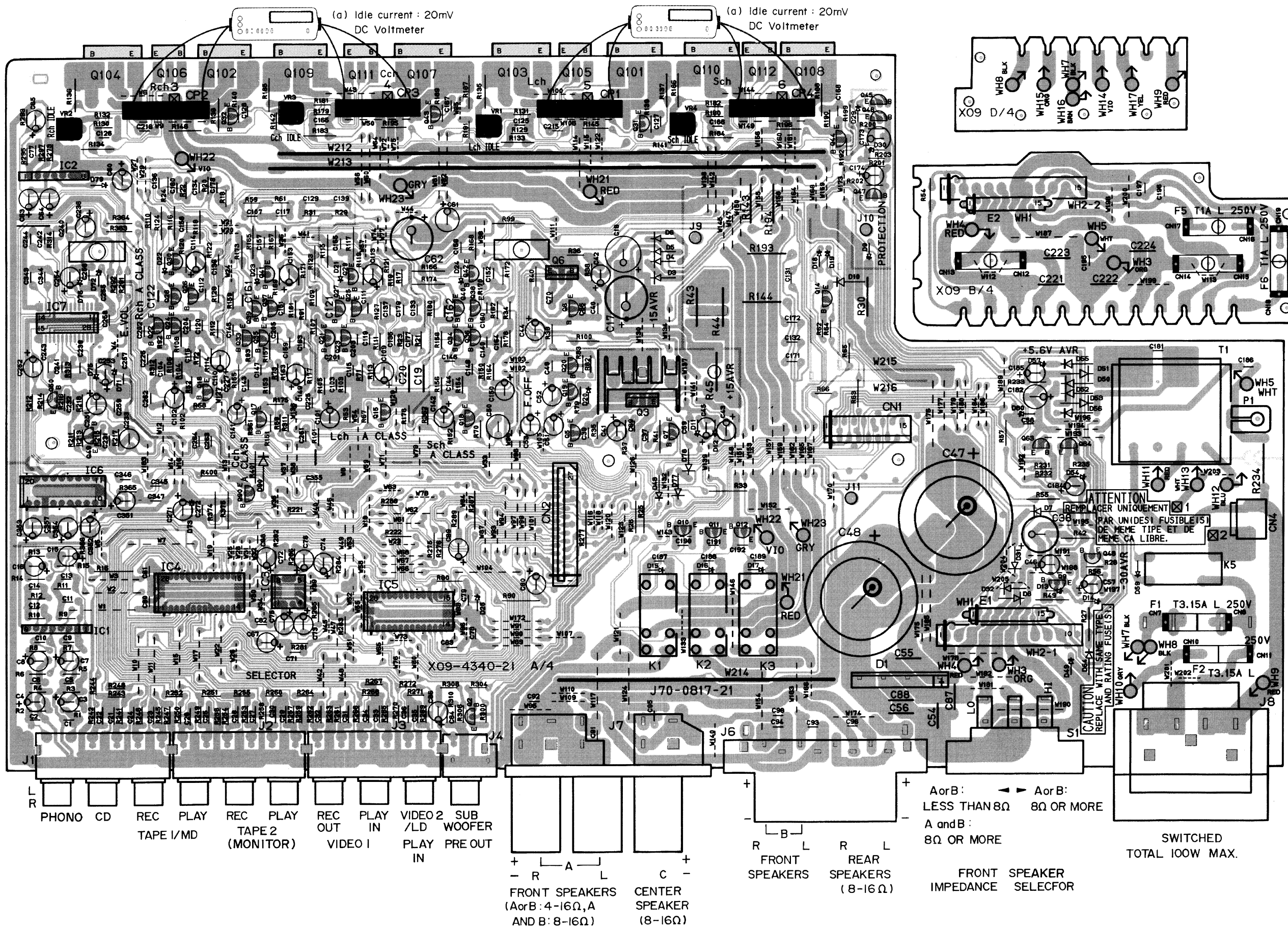

1
2
3
4
5
6
7

X14-4120-XX B/6 [X90-3010-20 (M) X90-3013-01 (C)] (TUNER UNIT) EXCEPT FOR EUROPE

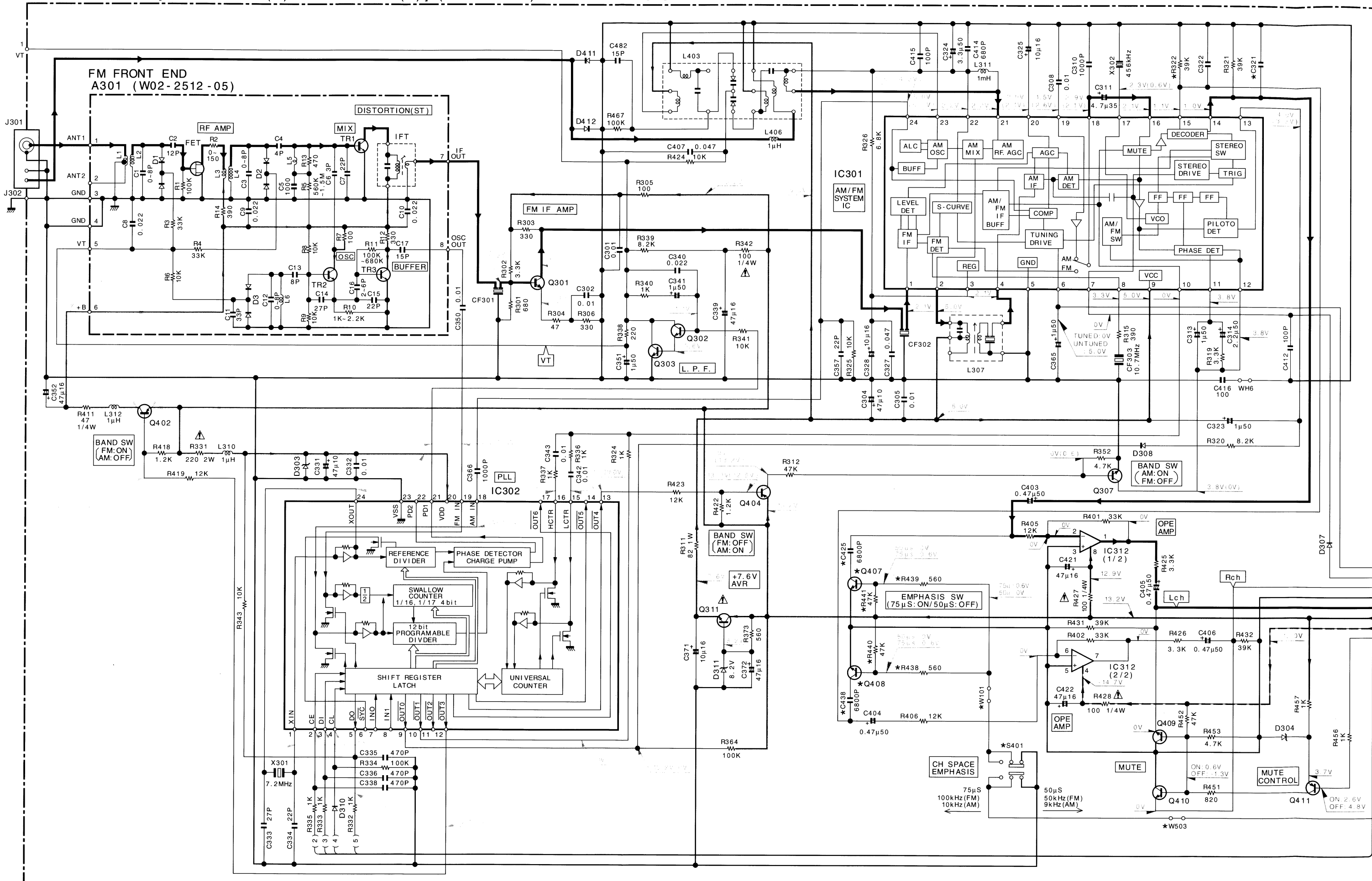

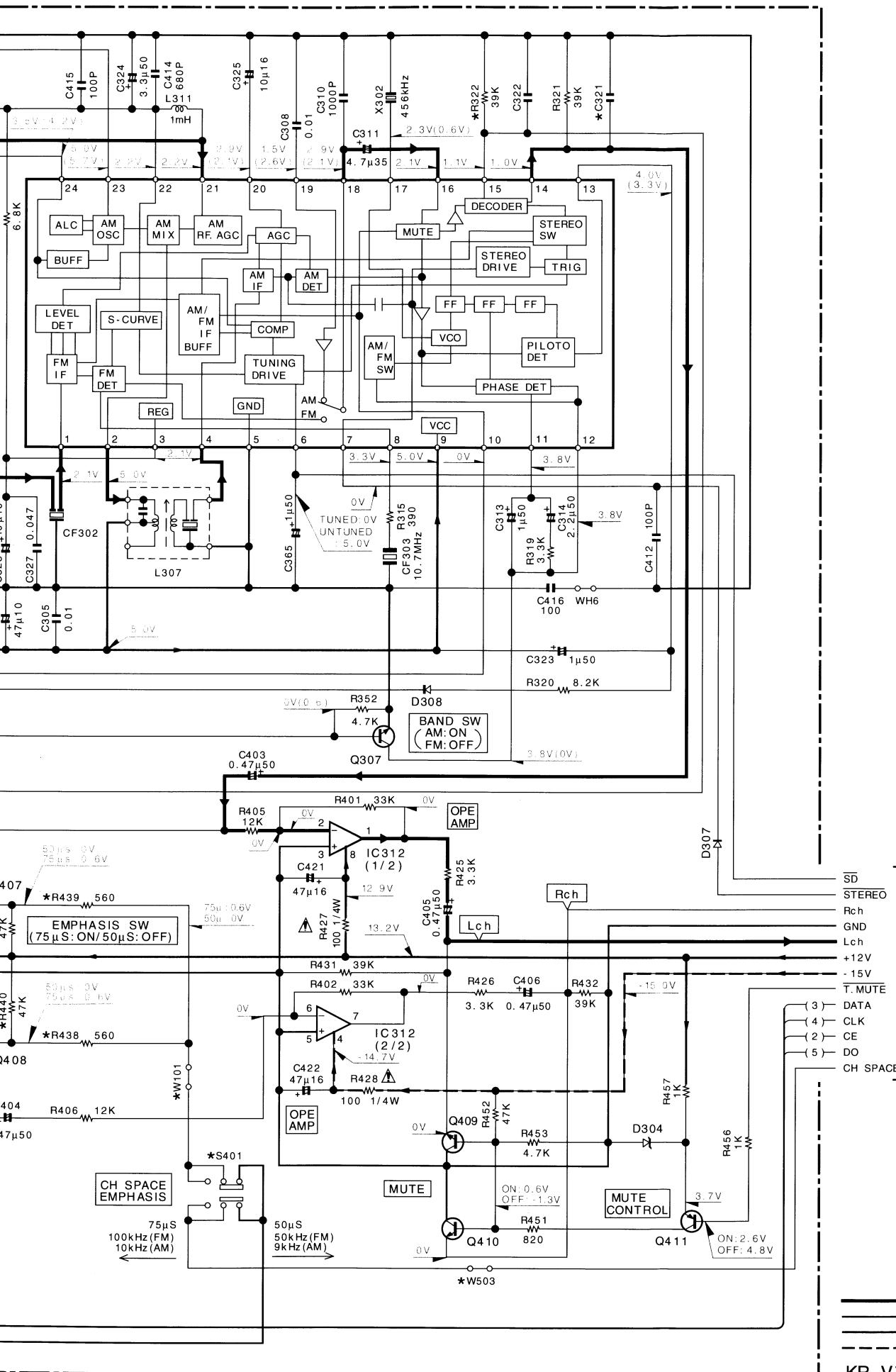

TO X14
TO X90
(A) 3/5
KR-V7080/V8080

- IC301 : LA1831A-KEN
- IC302 : LC7218
- IC312 : NJM4565D
- Q301 : 2SC2714 (R, O)
- Q302 : 2SC1845 (F, E)
- Q303 : 2SC2458 (Y, GR) or 2SC3311A (Q, R)
- Q307, 407, 408 : 2SC4081 (R, S) or 2SC4116 (Y, GR)
- Q311 : 2SC3940A (R, S) or 2SD863 (E, F)
- Q402, 404, 411 : 2SA1576A (R, S) or 2SA1586 (Y, GR)
- Q409, 410 : 2SD1757K
- D303 : RD5. 1ES (B2) or HZS5. 1N (B2)
- D304 : RD3. 3ES (B2) or HZS3. 3N (B2)
- D307, 308 : 1SS133 or HSS104
- D310, 411, 412 : MA111
- D311 : RD8. 2ES (B2) or HZS8. 2N (B2)

MODEL NAME	DESTINATION		UNIT NO.	C321, C322,	R438-R441, C425, C438, Q407, Q408, S401, W101, W503
	COUNTRY	ABB.			
KR-V7080	U. S. A.	K	20-10	0.024	NO
	CANADA	P	20-71		
	AUSTRALIA	X	20-71		
KR-V8080	GENERAL MARKET	Y	20-21	0.016	YES
	CHINA	M			
KR-V8080	U. S. A.	K	20-11	0.024	NO
	CANADA	P			

KR-V7080/V8080 (1/5)

CAUTION: For continued safety, replace safety critical components only with manufacturer's recommended parts (refer to parts list). Δ indicates safety critical components. For continued protection against risk of fire, replace only with same type and rating fuse(s). To reduce the risk of electric shock, leakage-current or resistance measurements shall be carried out (exposed parts are acceptably insulated from the supply circuit) before the appliance is returned to the customer.

The DC voltage is an actual reading measured with a high impedance type voltmeter as the AM/FM signal generator is specified to the conditions as shown in the list below. The measurement value may vary depending on the measuring instruments used or on the product. The value shown in () is actual reading measured in the AM mode.

MODE	CARRIER	MODULATION		ANT INPUT
		FREQUENCY	DEVIATION	
FM	98MHz	1kHz	STEREO 67.5kHz 7.5kHz(Pilot)	60dB
AM	1000(999)kHz	400Hz	MONO 30% MOD	60dB

2SA1123 2SA1534A 2SA992 2SC1845 2SC2003 2SC2631	2SC2878 2SC3940A 2SD863	DTC124ES 2SA1048 2SC2458	DTC124EU 2SA1586 2SC2714 2SC4081 2SC4116 2SD1757K
2SB1370 2SD2061	UN4212 UN4219 2SA1309A 2SC3311A	2SB1375 2SD2012	2SB1559 2SD2389
TDA7315	SAA6579	M5223P NJM4580D-D NJM4580L-D	UN5
LA2786	NJM4565L-D	LC7218 LV1015	NJU7311 NJU7312

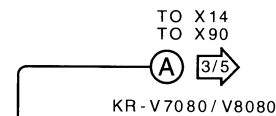

CAUTION: For continued safety, replace safety critical components only with manufacturer's recommended parts (refer to parts list). ⚡ indicates safety critical components. For continued protection against risk of fire, replace only with same type and rating fuse(s). To reduce the risk of electric shock, leakage-current or resistance measurements shall be carried out (exposed parts are acceptably insulated from the supply circuit) before the appliance is returned to the customer.

The DC voltage is an actual reading measured with a high impedance type voltmeter as the AM/FM signal generator is specified to the conditions as shown in the list below. The measurement value may vary depending on the measuring instruments used or on the product. The value shown in () is actual reading measured in the AM mode.

MODE	CARRIER	MODULATION		ANT INPUT
		FREQUENCY	DEVIATION	
FM	98MHz	1kHz	STEREO 67.5kHz 7.5kHz(Pilot)	60dB
AM	1000(999)kHz	400Hz	MONO 30% MOD	60dB

2SA1123
2SA1534A
2SA992
2SC1845
2SC2003
2SC2631

2SC2878
2SC3940A
2SD863

DTC124ES
2SA1048
2SC2458

DTC124EU
2SA1586
2SC2714
2SC4081
2SC4116
2SD1757K

2SB1470 *5
2SC4137F50
2SD2222 *5

IC301 : LA1831A-KEN
IC302 : LC7218
IC312 : NJM4565D

Q301 : 2SC2714(R, O)
Q302 : 2SC1845(F, E)
Q303 : 2SC2458(Y, GR) or
2SC3311A(Q, R)

Q307, 407, 408 : 2SC4081(R, S) or
2SC4116(Y, GR)

Q311 : 2SC3940A(R, S) or
2SD863(E, F)

Q402, 404, 411 : 2SA1576A(R, S) or
2SA1586(Y, GR)

Q409, 410 : 2SD1757K

D303 : RD5. 1ES(B2) or
HZS5. 1N(B2)

D304 : RD3. 3ES(B2) or
HZS3. 3N(B2)

D307, 308 : 1SS133 or
HSS104

D310, 411, 412 : MA111
D311 : RD8. 2ES(B2) or
HZS8. 2N(B2)

2SB1370
2SD2061

UN4212
UN4219
2SA1309A
2SC3311A

2SB1375
2SD2012

2SB1559
2SD2389

NJM4565D

NJM2279D

TDA7315

SAA6579

M5223P
NJM4580D-D
NJM4580L-D

UN5212

LA1836

UPD78044AGF160
UPD78045AGF027

LA2786

NJM4565L-D

LC7218
LV1015

NJU7311AL
NJU7312AL

MODEL NAME	DESTINATION		UNIT NO.	C321, C322,	R438-R441, C425, C438, Q407, Q408, S401, W101, W503
	COUNTRY	ABB.			
KR-V7080	U. S. A. CANADA	K P	20-10	0.024	NO
	AUSTRALIA	X	20-71	0.016	YES
	PX	Y	20-21		
KR-V8080	GENERAL MARKET CHINA	M C	20-11	0.024	NO
	U. S. A. CANADA	K P	20-11	0.024	NO

— SIGNAL LINE
— GND LINE
— +B LINE
— -B LINE

X14-4132-70 (E.T TYPE) (TUNER UNIT) KR-V7080 ONLY

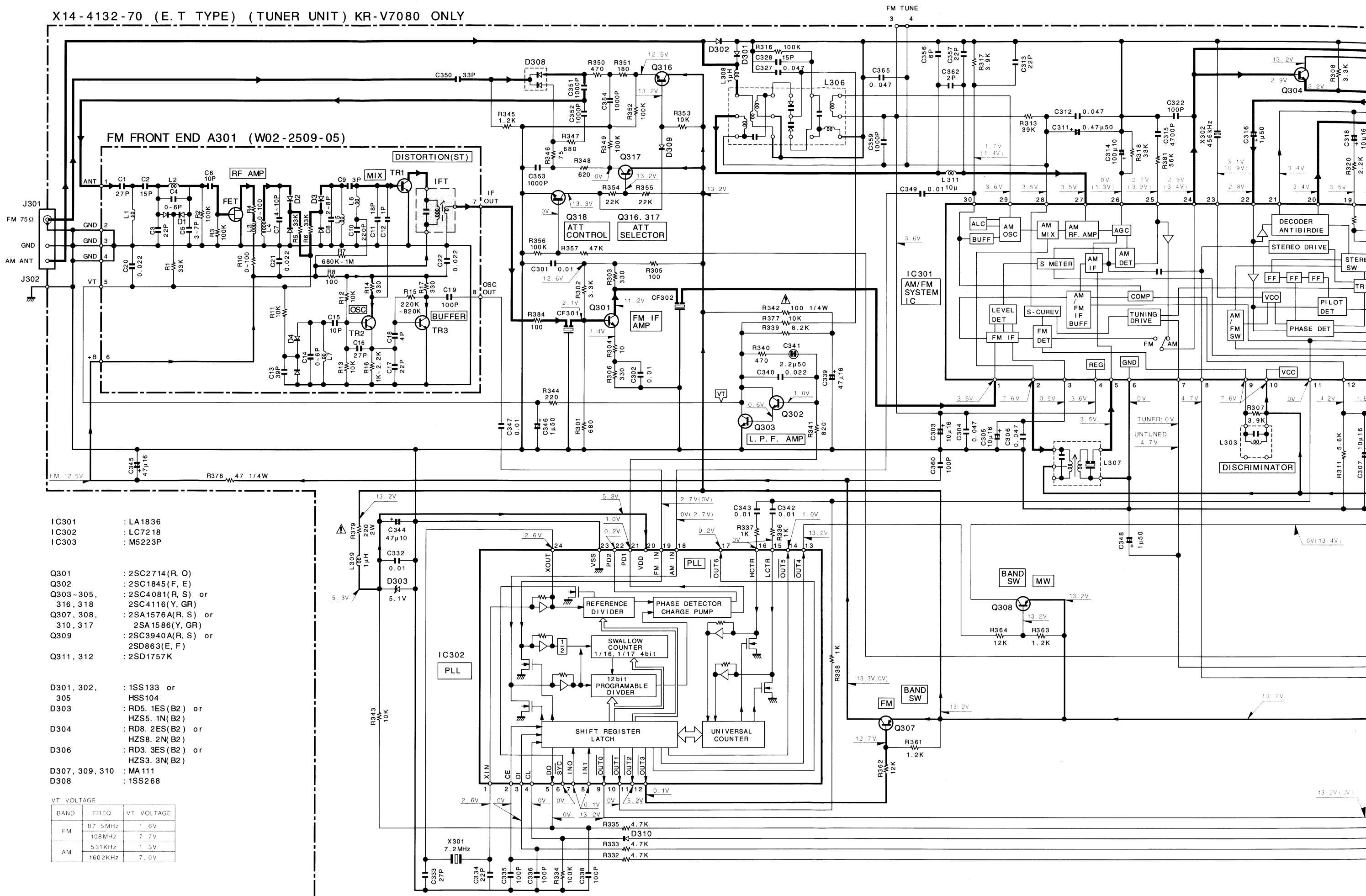

- IC301 : LA1836
- IC302 : LC7218
- IC303 : M5223P

- Q301 : 2SC2714 (R, O)
- Q302 : 2SC1845 (F, E)
- Q303-305, 316, 318 : 2SC4081 (R, S) or 2SC4116 (Y, GR)
- Q307, 308, 310, 317 : 2SA1576A (R, S) or 2SA1586 (Y, GR)
- Q309 : 2SC3940A (R, S) or 2SD863 (E, F)
- Q311, 312 : 2SD1757K

- D301, 302, 305 : 1SS133 or HSS104
- D303 : RD5. 1ES (B2) or HZS5. 1N (B2)
- D304 : RD8. 2ES (B2) or HZS8. 2N (B2)
- D306 : RD3. 3ES (B2) or HZS3. 3N (B2)
- D307, 309, 310 : MA111
- D308 : 1SS268

VT VOLTAGE		
BAND	FREQ	VT VOLTAGE
FM	87.5MHz	1.6V
	108MHz	7.7V
AM	531KHz	1.3V
	1602KHz	7.0V

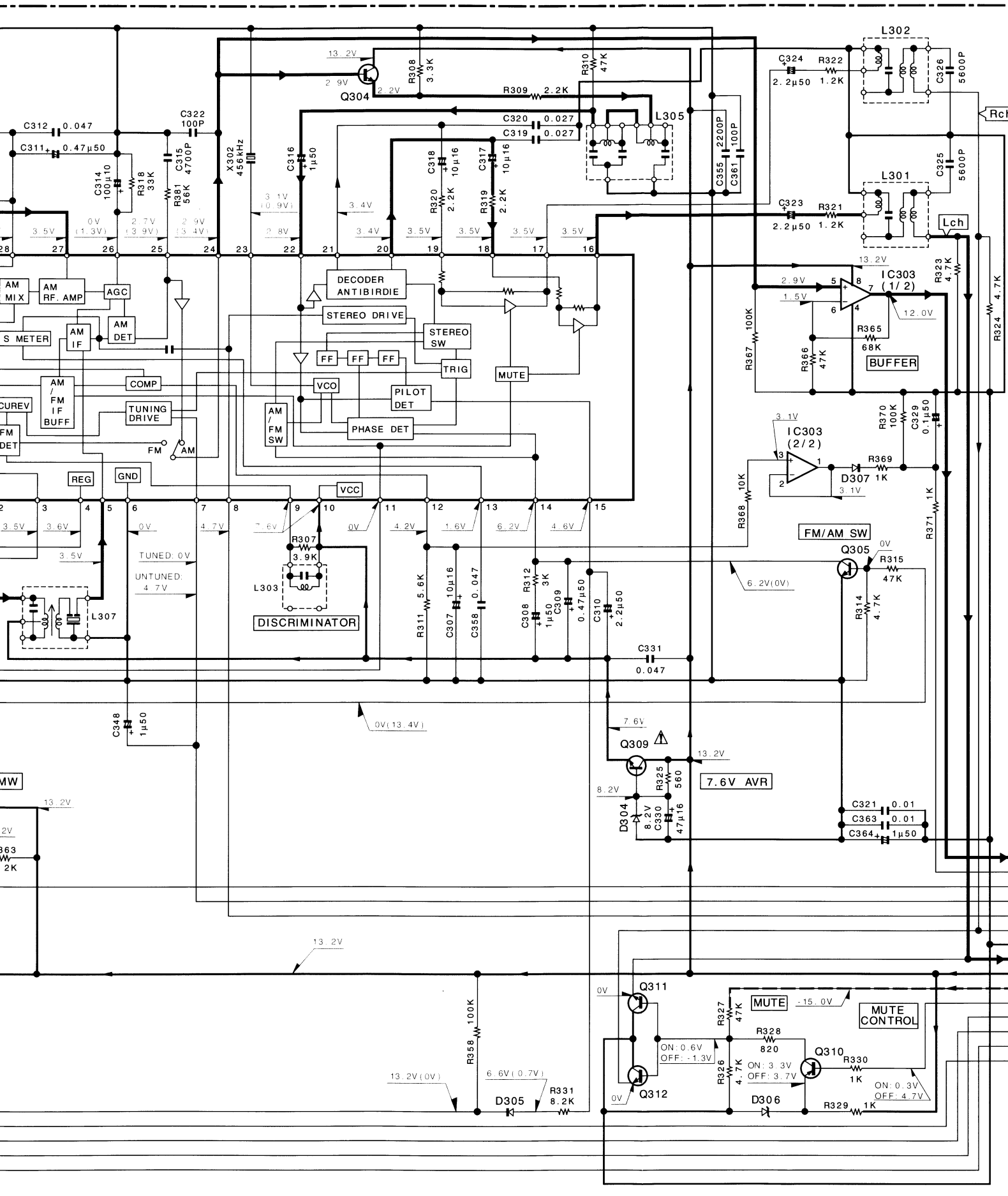

TO X14
KR-V7080

(A) 3/5

CAUTION: For continued safety, replace safety critical components only with manufacturer's recommended parts (refer to parts list). ⚠ indicates safety critical components. For continued protection against risk of fire, replace only with same type and rating fuse(s). To reduce the risk of electric shock, leakage-current or resistance measurements shall be carried out (exposed parts are acceptably insulated from the supply circuit) before the appliance is returned to the customer.

The DC voltage is an actual reading measured with a high impedance type voltmeter as the AM/FM signal generator is specified to the conditions as shown in the list below. The measurement value may vary depending on the measuring instruments used or on the product. The value shown in () is actual reading measured in the AM mode.

MODE	CARRIER	MODULATION		ANT INPUT
		FREQUENCY	DEVIATION	
FM	98MHz	1kHz	STEREO 67.5kHz 7.5kHz(Pilot)	60dB
AM	1000(999)kHz	400Hz	MONO 30% MOD	60dB

- IC1 : NJM4580L-D Q2, 15-18 : 2SC2878(B)
- IC2 : NJM4565L-D 49, 50
- IC3 : NJM4580D-D
- IC4 : NJU7312AL Q3 : 2SD2061(E, F) or 2SD2012
- IC5 : NJU7311AL Q8, 14 : 2SA1048(Y, GR) or 2SA1309A(Q, R)
- IC6 : TDA7315 Q5, 7, 20 : 2SC2458(Y, GR) or 2SC3311A(Q, R)
- IC7 : TDA7345D Q9 : 2SA1534A(R, S)
- Q10-12 : UN4219 or DTC113ZS
- Q19, 90 : UN4212 or DTC124ES
- Q21-24, 33-36 : 2SA992(F, E)
- 47, 48
- Q25-28, 37-40 : 2SC2631(R, S)

X90-434x-xx (A/4)
 X90-3010-20 (M TYPE)
 X90-3013-01 (C TYPE)

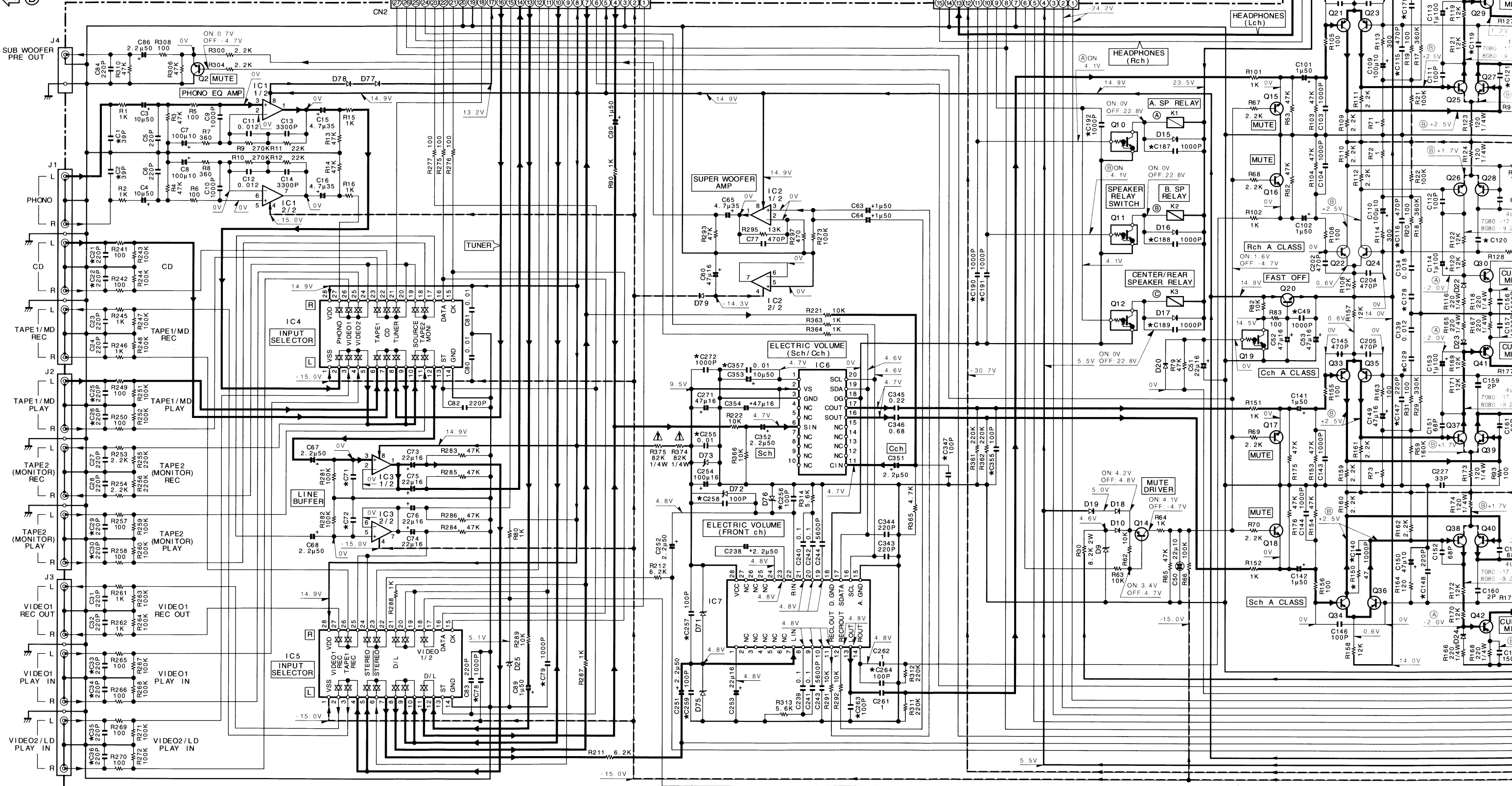

- Q29, 30, 41, 42 : 2SA1123(R, S)
- Q31, 32, 43-46 : 2SC1845(F, E)
- Q63 : 2SC2003(L, K)
- Q64 : 2SC3940A(R, S)
- Q101, 102 : 2SD2222*5
- Q103, 104 : 2SB1470*5
- Q105, 106 : 2SC4137F50(V, W)
- 111, 112
- Q107, 108 : 2SD2389
- Q109, 110 : 2SB1559
- D1 : RBV-602LFA
- D3-8, 31, 32 : S5688B or 1SR139-100
- 50-53, 77, 78
- D9 : RD4.7ES(B2) or HZS4.7N(B2)
- D10, 15-20 : HSS104 or 1SS133
- 48, 59, 79, 90
- D11, 54 : RD6.2ES(B2) or HZS6.2N(B2)
- D12, 71, 72 : RD8.2ES(B2) or HZS8.2N(B2)
- 75, 76 : RD16ES(B2) or HZS16N(B2)
- D13, 14 : HSS104A or 1SS131
- 55, 56, 64
- D25, 30, 80 : RD5.1ES(B2) or HZS5.1N(B2)
- D57 : RD2.7ES(B2) or HZS2.7N(B2)
- D73 : RD10ES(B) or HZS10N(B)

- 41, 42 : 2SA1123(R, S)
- 43-46 : 2SC1845(F, E)
- : 2SC2003(L, K)
- : 2SC3940A(R, S)
- : 2SD2222*5
- : 2SB1470*5
- : 2SC4137F50(V, W)
- : 2SD2389
- : 2SB1559
- D1 : RBV-602LFA
- D3-8, 31, 32 : S5688B or 1SR139-100
- 50-53, 77, 78
- D9 : RD4.7ES(B2) or HZS4.7N(B2)
- D10, 15-20 : HSS104 or 48, 59, 79, 90 1SS133
- D11, 54 : RD6.2ES(B2) or HZS6.2N(B2)
- D12, 71, 72 : RD8.2ES(B2) or HZS8.2N(B2)
- 75, 76 : HZS8.2N(B2)
- D13, 14 : RD16ES(B2) or HZS16N(B2)
- D21-24, 29, 49 : HSS104A or 55, 56, 64 1SS131
- D25, 30, 80 : RD5.1ES(B2) or HZS5.1N(B2)
- D57 : RD2.7ES(B2) or HZS2.7N(B2)
- D73 : RD10ES(B) or HZS10N(B)

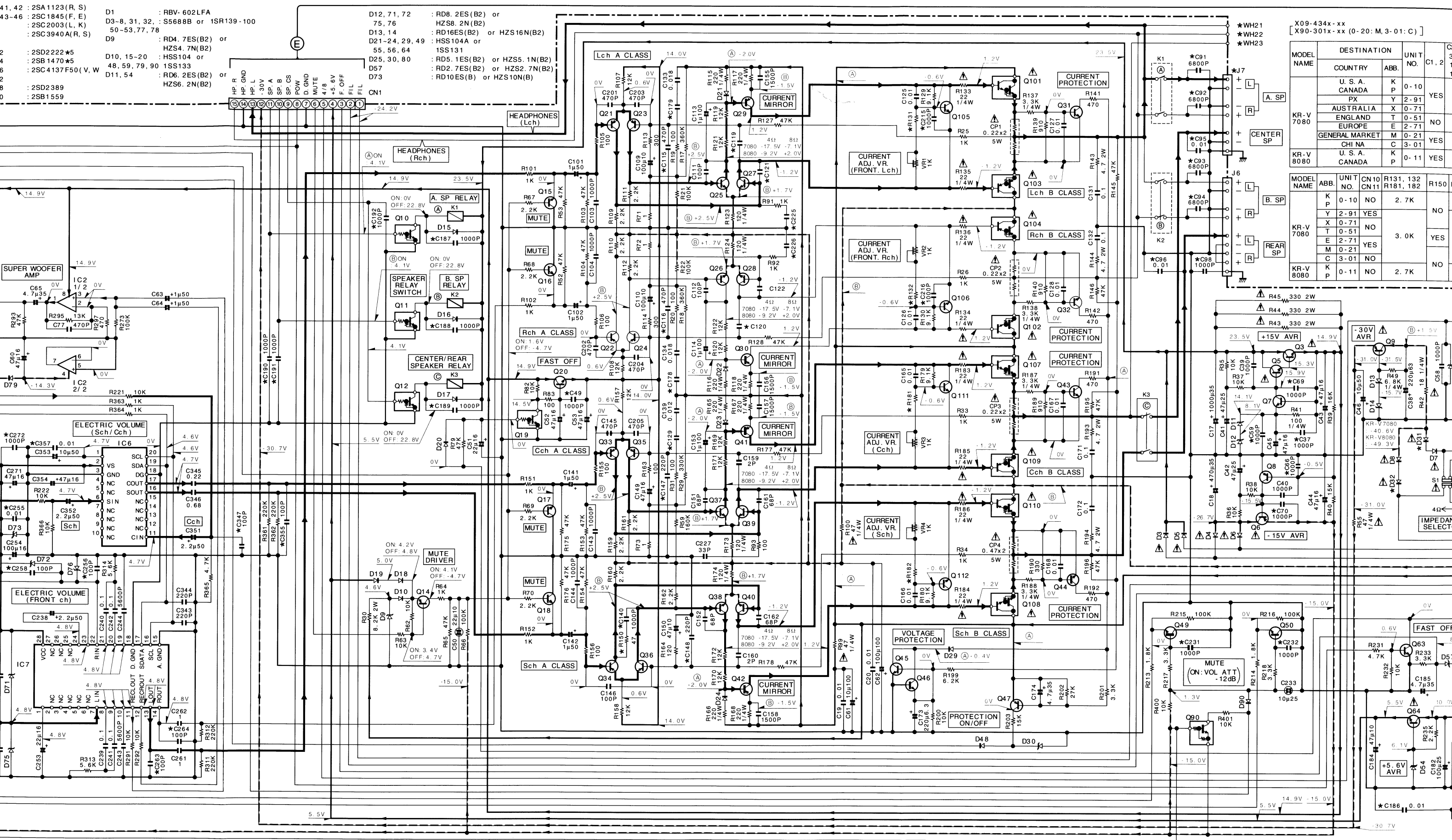

X09-434x-xx
X90-301x-xx (0-20; M, 3-01; C)

MODEL NAME	DESTINATION		UNIT NO.	C1, 2	C3
	COUNTRY	ABB.			
KR-V 7080	U. S. A.	K	0-10		
	CANADA	P	2-91	YES	
	AUSTRALIA	X	0-71		
	ENGLAND	T	0-51		
KR-V 8080	EUROPE	E	2-71	NO	
	GENERAL MARKET	M	0-21	YES	
	CHI NA	C	3-01		
KR-V 7080	U. S. A.	K	0-11	YES	
	CANADA	P	2-7K		
KR-V 8080	K	0-10	NO	2.7K	NO
	P	2-91	YES		
	Y	0-71	NO		
	X	0-51	NO		
	T	2-71	YES	3.0K	YES
	M	0-21	NO		
KR-V 8080	C	3-01	NO	2.7K	NO
	K	0-11	NO		

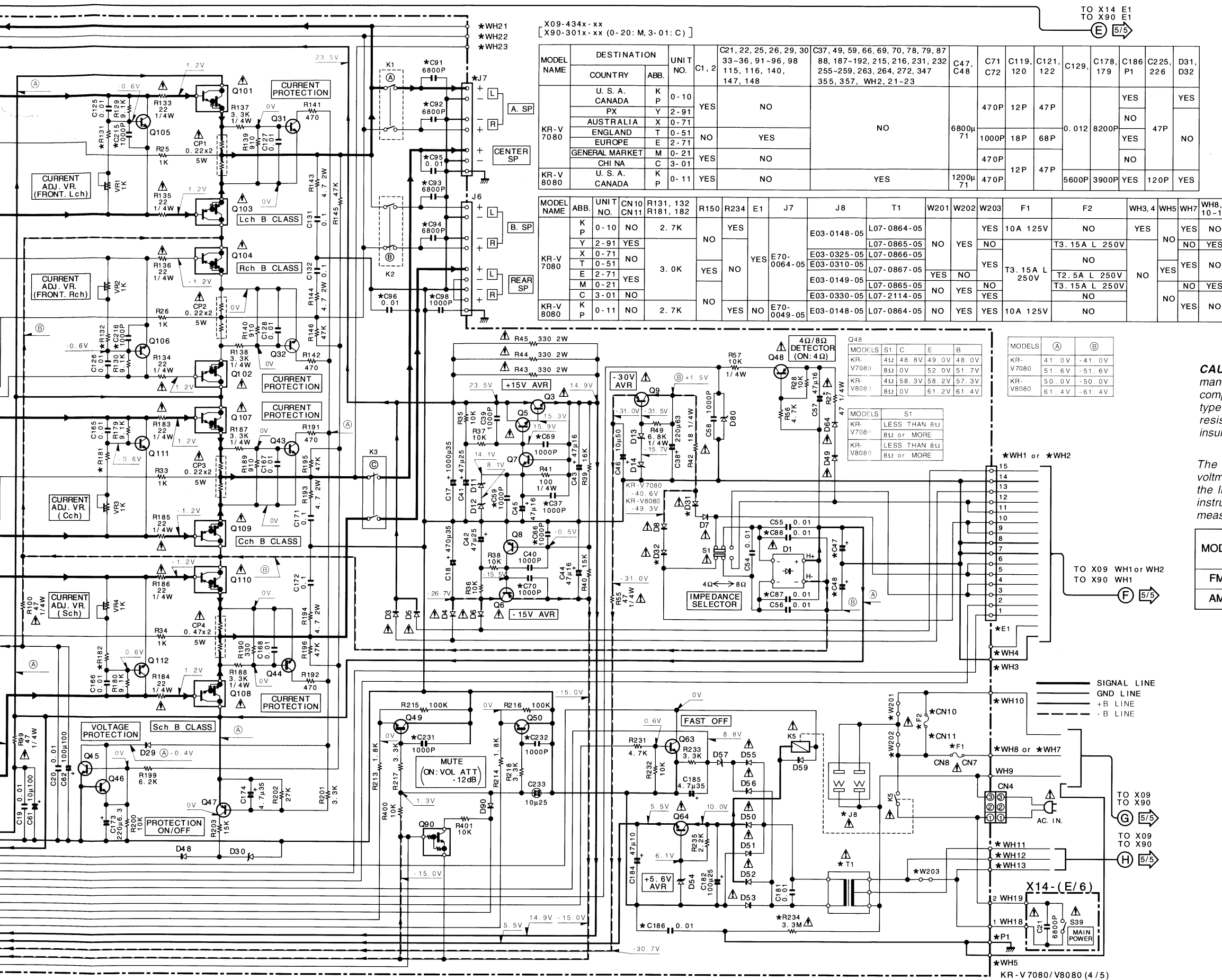

X09-434x-xx
X90-301x-xx (0-20: M, 3-01: C)

MODEL NAME	DESTINATION	UNIT NO.	C1, 2	C21, 22, 25, 26, 29, 30	C37, 49, 59, 66, 69, 70, 78, 79, 87	C47, C48	C71, C72	C119, 120	C121, 122	C129,	C178, 179	C186, P1	C225, 226	D31, D32	
KR-V 7080	U. S. A.	K	0-10	NO	NO	NO	470P	12P	47P	0.012	8200P	NO	47P	YES	
	CANADA	P	2-91	YES	NO	NO	1000P	18P	68P	NO	NO	NO	NO	NO	
	AUSTRALIA	X	0-71	NO	YES	NO	470P	NO	NO	NO	NO	NO	NO	NO	
	ENGLAND	T	0-51	NO	NO	NO	NO	NO	NO	NO	NO	NO	NO	NO	
	EUROPE	E	2-71	NO	NO	NO	NO	NO	NO	NO	NO	NO	NO	NO	
GENERAL MARKET	M	0-21	YES	NO	NO	NO	NO	NO	NO	NO	NO	NO	NO		
CHI NA	C	3-01	NO	NO	NO	NO	NO	NO	NO	NO	NO	NO	NO		
KR-V 8080	U. S. A.	K	0-11	YES	NO	YES	1200P	470P	12P	47P	5600P	3900P	YES	120P	YES

MODEL NAME	ABB.	UNIT NO.	CN 10, CN 11	R131, R132, R181, 182	R150	R234	E1	J7	J8	T1	W201	W202	W203	F1	F2	WH3, 4	WH5	WH7	WH8, 10-13	
KR-V 7080	K	0-10	NO	2.7K	NO	YES	NO	NO	E03-0148-05	L07-0864-05	NO	YES	NO	10A 125V	NO	YES	NO	YES	NO	
	Y	2-91	YES	NO	NO	NO	YES	E70-0064-05	L07-0865-05	L07-0866-05	NO	YES	NO	T3. 15A L 250V	NO	NO	NO	NO	YES	
	X	0-71	NO	3.0K	NO	NO	NO	NO	E03-0325-05	L07-0866-05	NO	YES	NO	NO	NO	NO	YES	NO	NO	
	T	0-51	NO	NO	NO	NO	NO	NO	E03-0310-05	L07-0867-05	NO	YES	NO	T3. 15A L 250V	NO	NO	YES	NO	NO	
	E	2-71	YES	NO	NO	NO	NO	NO	E03-0149-05	L07-0865-05	NO	YES	NO	T2. 5A L 250V	NO	NO	NO	YES	NO	
M	0-21	NO	NO	NO	NO	NO	NO	NO	E03-0330-05	L07-2114-05	NO	YES	NO	NO	NO	NO	NO	YES	NO	
C	3-01	NO	NO	2.7K	NO	NO	NO	NO	E03-0330-05	L07-2114-05	NO	YES	NO	NO	NO	NO	NO	YES	NO	
KR-V 8080	K	0-11	NO	2.7K	NO	YES	NO	NO	E70-0049-05	E03-0148-05	L07-0864-05	NO	YES	YES	10A 125V	NO	NO	NO	YES	NO

CAUTION: For continued safety, replace safety critical components only with manufacturer's recommended parts (refer to parts list). ⚠ indicates safety critical components. For continued protection against risk of fire, replace only with same type and rating fuse(s). To reduce the risk of electric shock, leakage-current or resistance measurements shall be carried out (exposed parts are acceptably insulated from the supply circuit) before the appliance is returned to the customer.

The DC voltage is an actual reading measured with a high impedance type voltmeter as the AM/FM signal generator is specified to the conditions as shown in the list below. The measurement value may vary depending on the measuring instruments used or on the product. The value shown in () is actual reading measured in the AM mode.

MODE	CARRIER	MODULATION		ANT INPUT
		FREQUENCY	DEVIATION	
FM	98MHz	1kHz	STEREO 67.5kHz 7.5kHz(Pilot)	60dB
AM	1000(999)kHz	400Hz	MONO 30% MOD	60dB

KR-V7080/V8080

KENWOOD

TO X90
KR-V7080/V8080
TO X14
KR-V7080

X14-41xx-xx (B/6) [X90-3010-20 (M) X90-3013-01 (C)] (SURROUND UNIT)

SYSTEM CONTROL
XS8
SL16

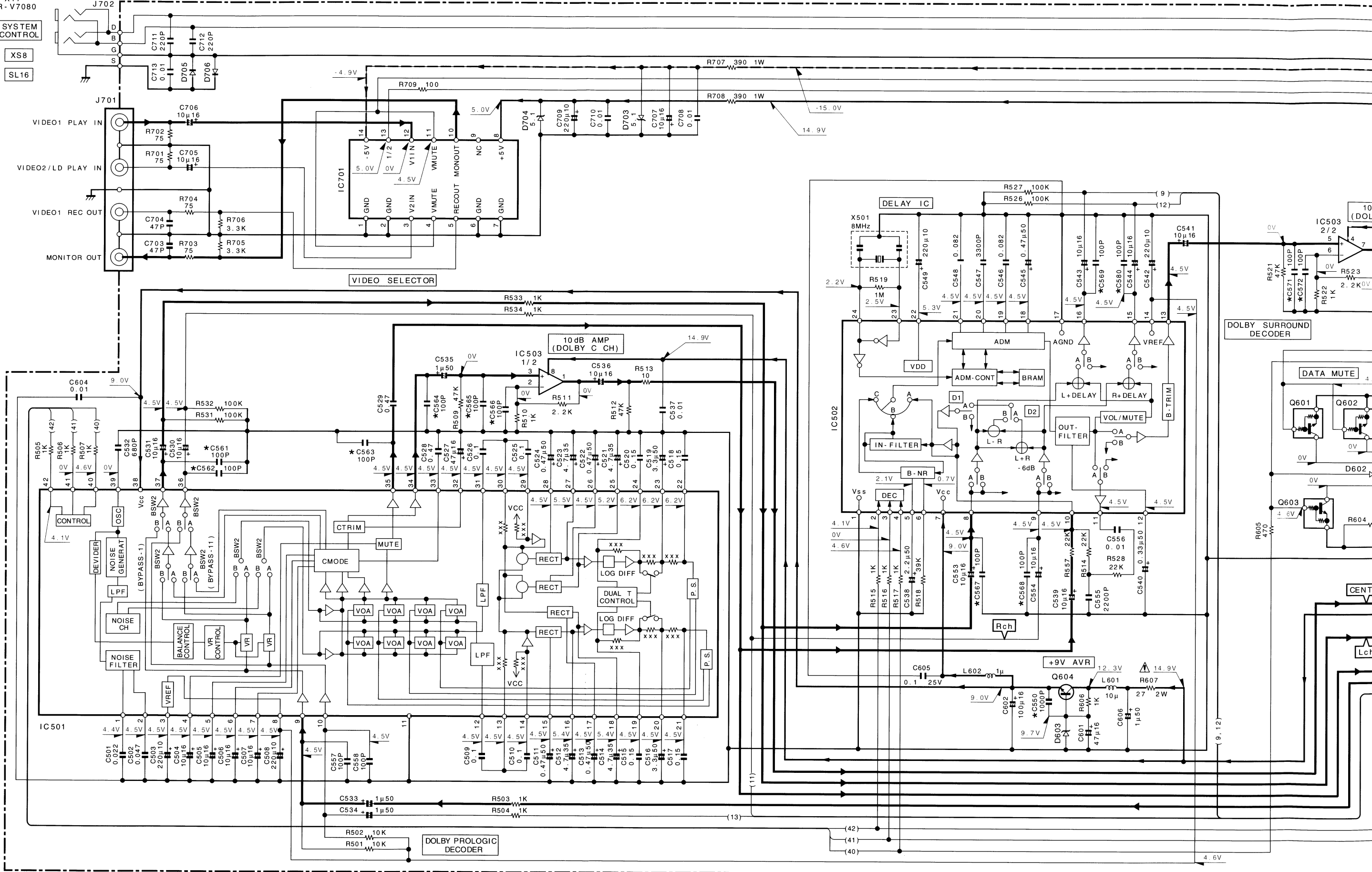

ND UNIT)

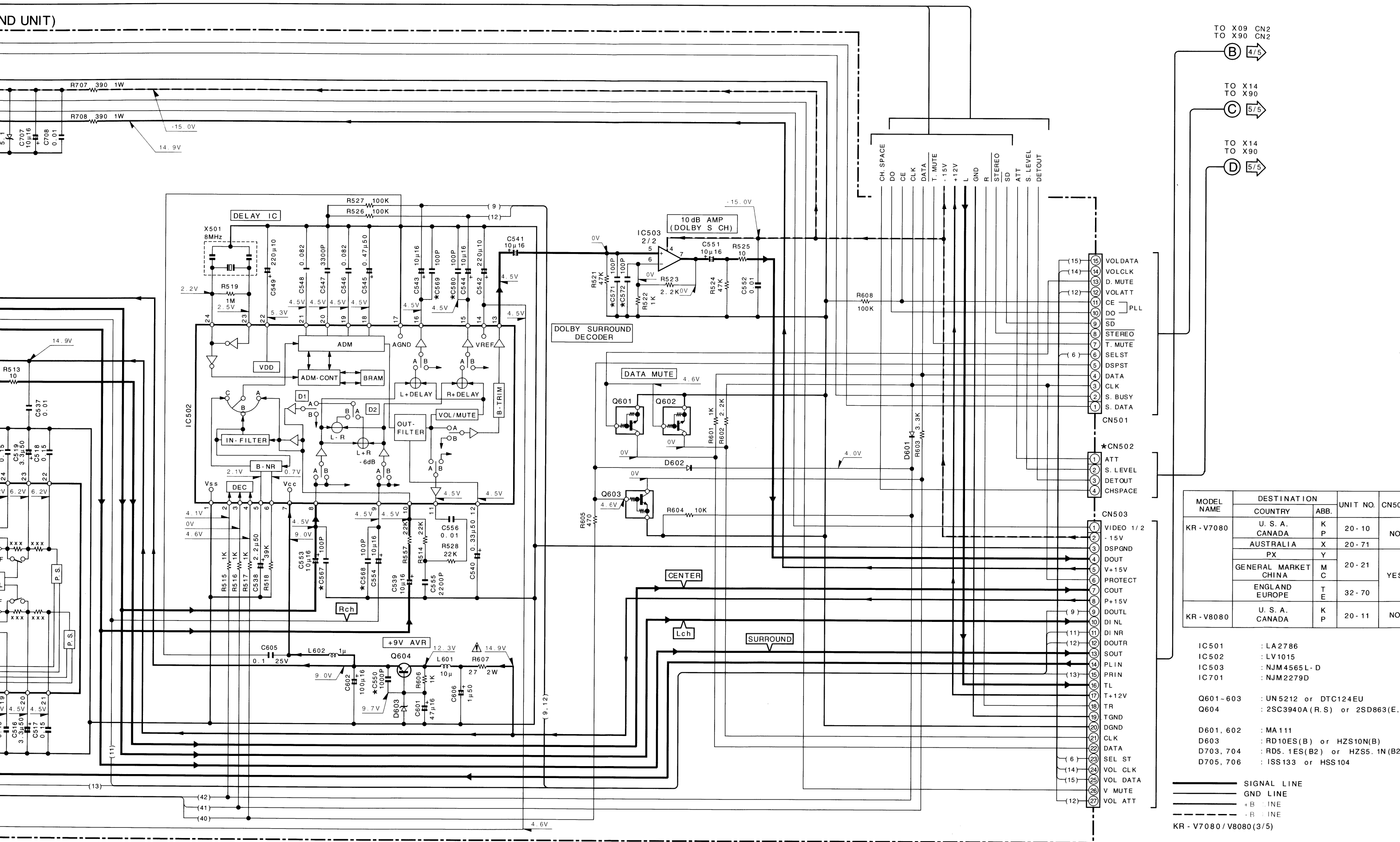

MODEL NAME	DESTINATION		UNIT NO.	CN501
	COUNTRY	ABB.		
KR - V7080	U. S. A.	K	20 - 10	NO
	CANADA	P		
	AUSTRALIA	X	20 - 71	
	PX	Y		
KR - V8080	GENERAL MARKET	M	20 - 21	YES
	CHINA	C		
KR - V8080	ENGLAND	T	32 - 70	NO
	EUROPE	E		
KR - V8080	U. S. A.	K	20 - 11	NO
	CANADA	P		

- IC 501 : LA 2786
- IC 502 : LV1015
- IC 503 : NJM4565L - D
- IC 701 : NJM2279D
- Q601 - 603 : UN 5212 or DTC124EU
- Q604 : 2SC3940A (R.S) or 2SD863 (E).
- D601, 602 : MA111
- D603 : RD10ES (B) or HZS10N (B)
- D703, 704 : RD5.1ES (B2) or HZS5.1N (B2)
- D705, 706 : ISS133 or HSS104

——— SIGNAL LINE
 - - - GND LINE
 ——— +B LINE
 - - - -B LINE

KR - V7080 / V8080 (3/5)

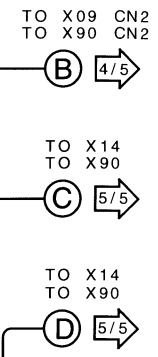
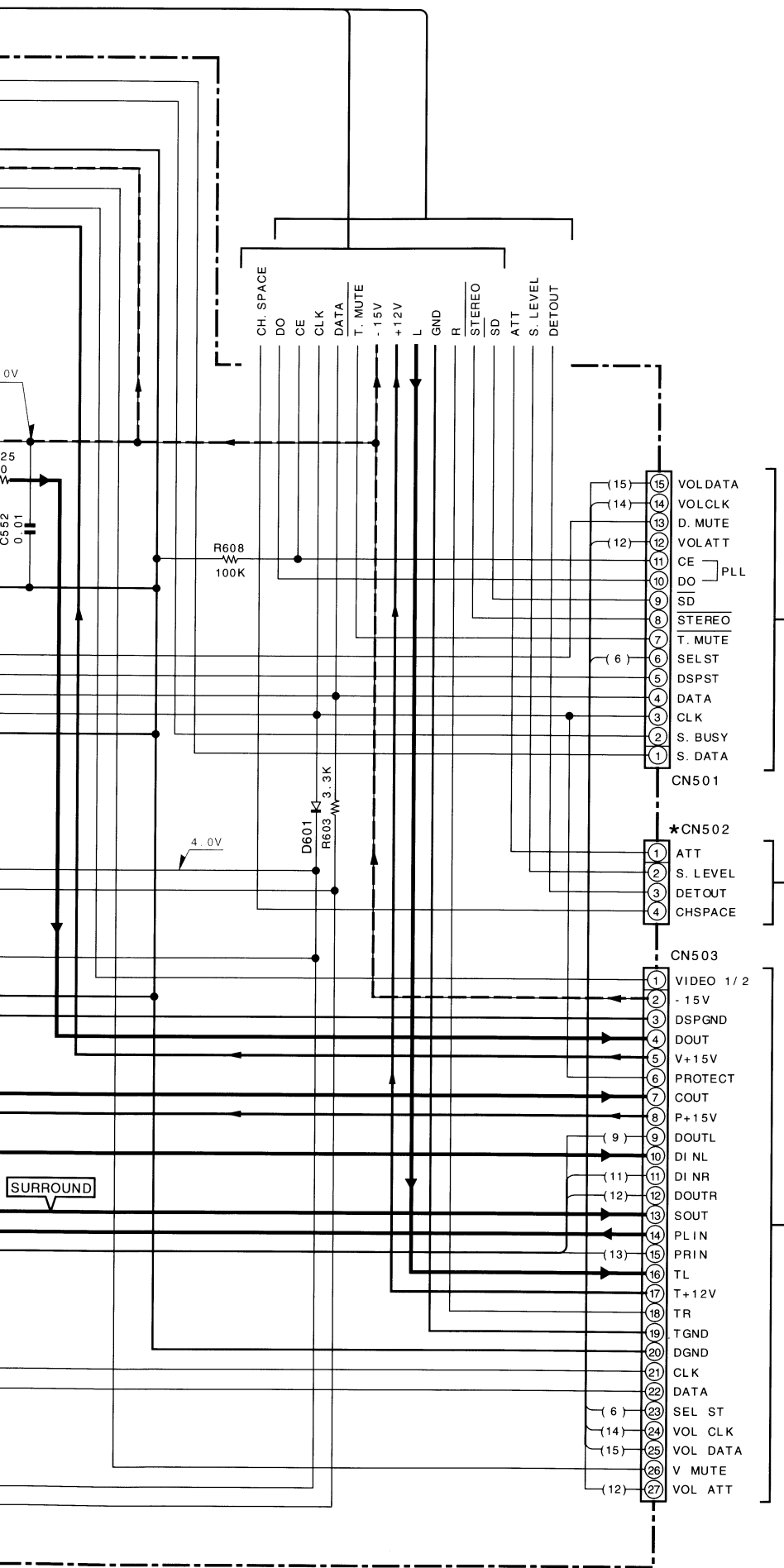

CAUTION: For continued safety, replace safety critical components only with manufacturer's recommended parts (refer to parts list). * indicates safety critical components. For continued protection against risk of fire, replace only with same type and rating fuse(s). To reduce the risk of electric shock, leakage current or resistance measurements shall be carried out (exposed parts are acceptably insulated from the supply circuit) before the appliance is returned to the customer.

The DC voltage is an actual reading measured with a high impedance type voltmeter as the AM/FM signal generator is specified to the conditions as shown in the list below. The measurement value may vary depending on the measuring instruments used or on the product. The value shown in () is actual reading measured in the AM mode.

MODE	CARRIER	MODULATION		ANT INPUT
		FREQUENCY	DEVIATION	
FM	98MHz	1kHz	STEREO 67.5kHz 7.5kHz(Pilot)	60dB
AM	1000(999)kHz	400Hz	MONO 30% MOD	60dB

MODEL NAME	DESTINATION		UNIT NO.	CN502	C550, C561-572
	COUNTRY	ABB.			
KR - V7080	U. S. A.	K	20 - 10	NO	YES
	CANADA	P	20 - 10		
	AUSTRALIA	X	20 - 71	YES	NO
	PX	Y	20 - 21		
	GENERAL MARKET CHINA	M	20 - 21		
KR - V8080	ENGLAND	T	32 - 70	NO	YES
	EUROPE	E	32 - 70		
KR - V8080	U. S. A.	K	20 - 11	NO	YES

- IC501 : LA2786
- IC502 : LV1015
- IC503 : NJM4565L-D
- IC701 : NJM2279D

- Q601-603 : UN5212 or DTC124EU
- Q604 : 2SC3940A(R.S) or 2SD863(E,F)

- D601, 602 : MA111
- D603 : RD10ES(B) or HZS10N(B)
- D703, 704 : RD5.1ES(B2) or HZS5.1N(B2)
- D705, 706 : ISS133 or HSS104

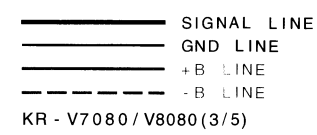

KR - V7080 / V8080 (3/5)

KR-V7080/V8080
KENWOOD

X14-41XX-XX A/6 [X90-3010-20 (M) X90-3013-01 (C)] (DISPLAY UNIT)

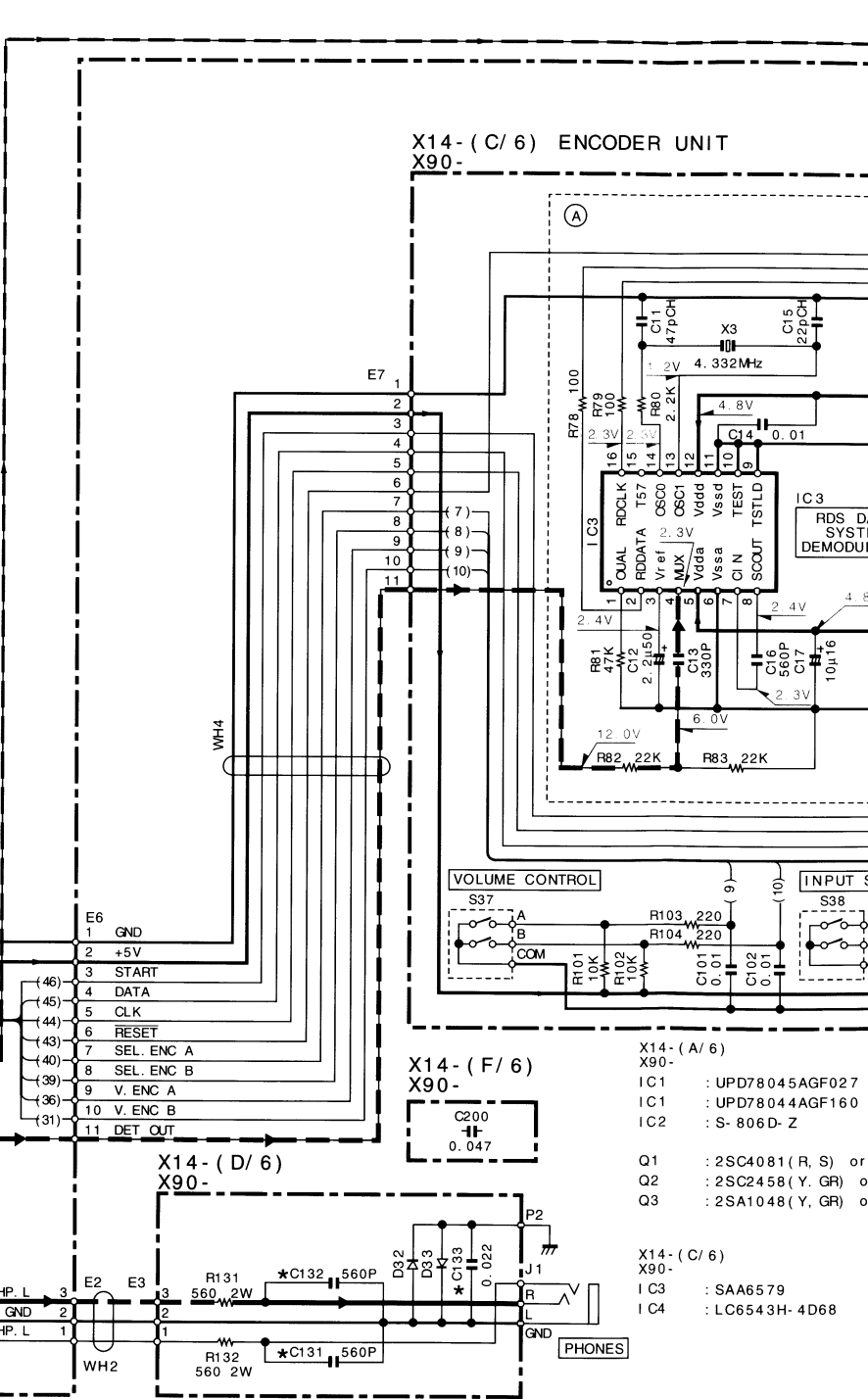
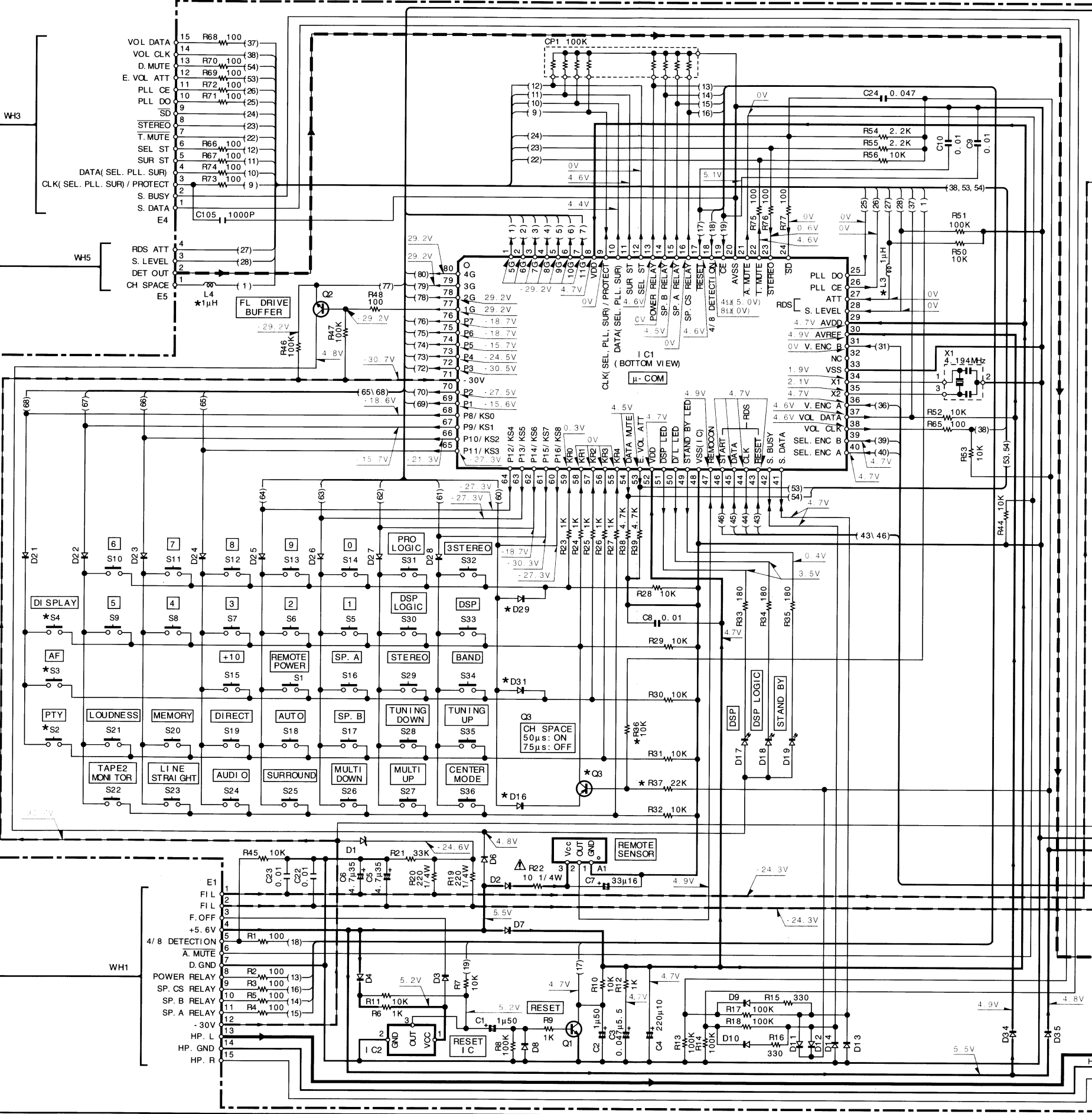

X14-(A/6) X90-

IC1 : UPD78045AGF027 ()
IC1 : UPD78044AGF160 ()
IC2 : S-806D-Z

Q1 : 2SC4081 (R, S) or 2SC4081 (Y, GR) or 2SC4081 (B, W)
Q2 : 2SC2458 (Y, GR) or 2SC2458 (B, W)
Q3 : 2SA1048 (Y, GR) or 2SA1048 (B, W)

X14-(C/6) X90-

IC3 : SAA6579
IC4 : LC6543H-4D68

1 (DISPLAY UNIT)

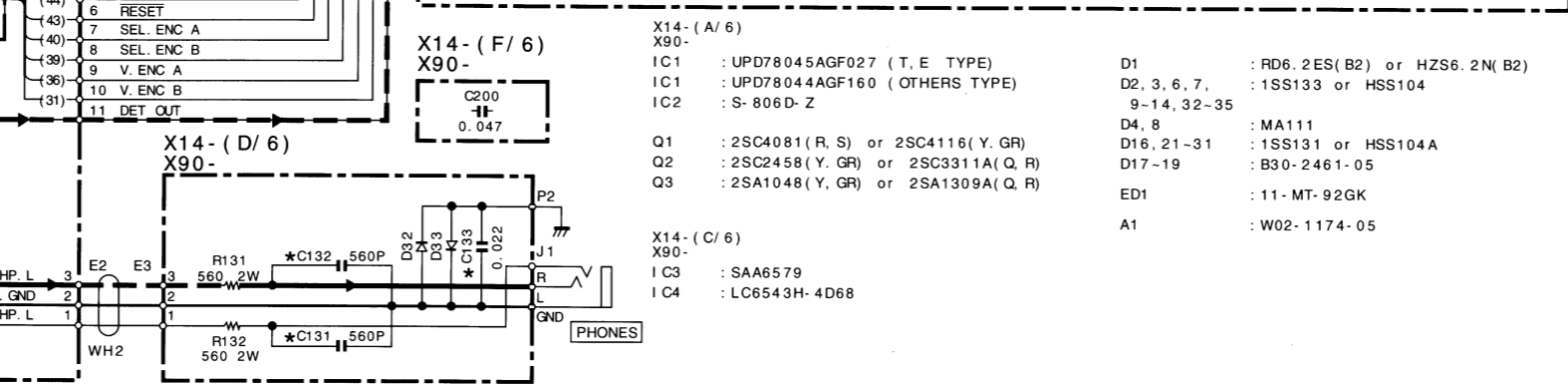
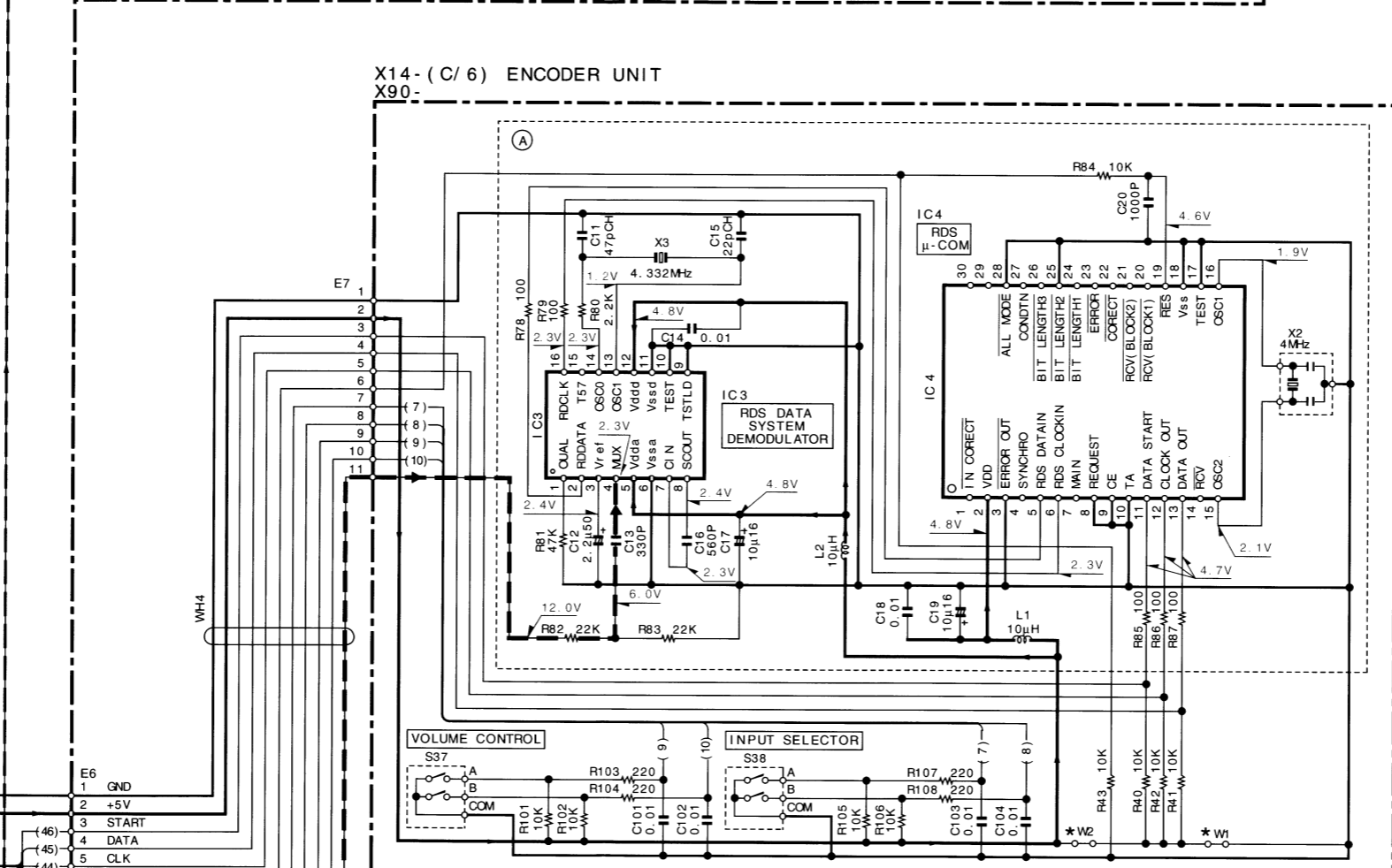
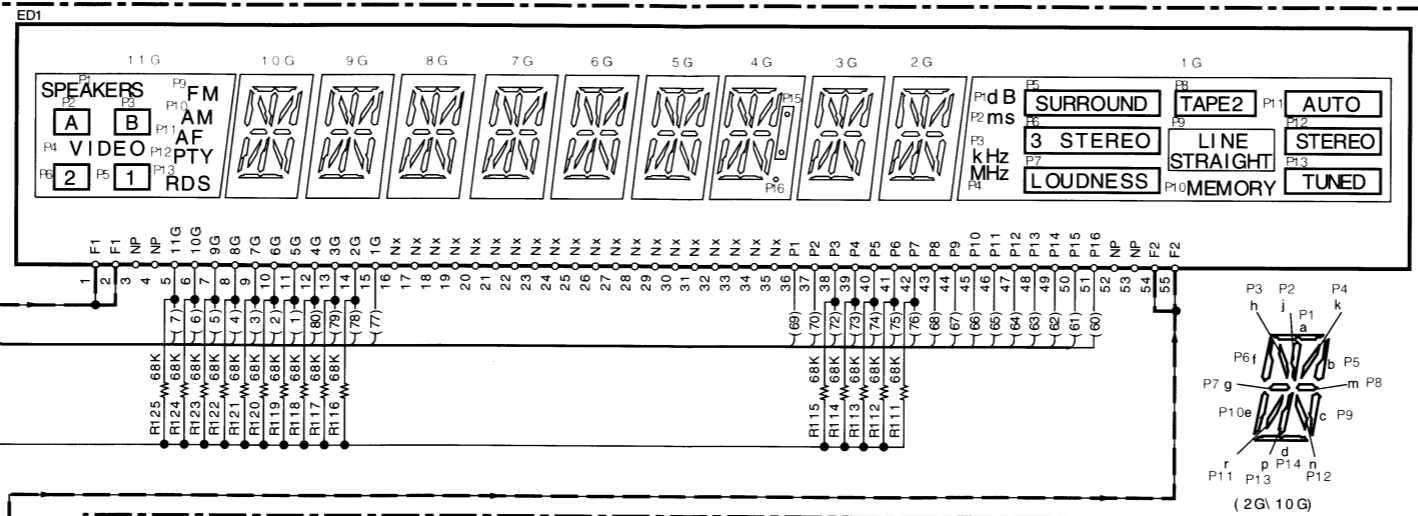
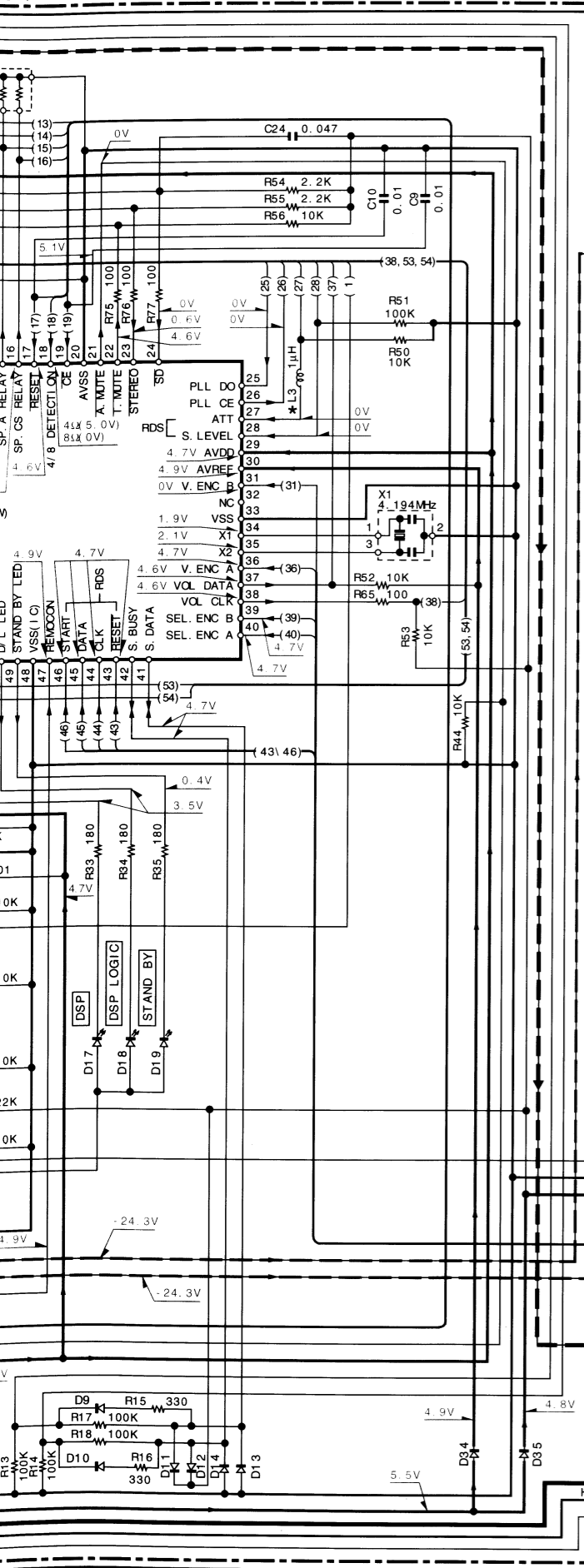

- X14-(A/6)**
X90-
IC1 : UPD78045AGF027 (T, E TYPE)
IC2 : S-806D-Z
- X14-(B/6)**
X90-
IC1 : UPD78044AGF160 (OTHERS TYPE)
IC2 : S-806D-Z
- X14-(C/6)**
X90-
IC3 : SAA6579
IC4 : LC6543H-4D68
- D1** : RD6.2ES(B2) or HZS6.2N(B2)
D2, 3, 6, 7 : 1SS133 or HSS104
D3 : 1SS131 or HSS104A
D4, 8 : MA111
D16, 21-31 : 1SS131 or HSS104A
D17-19 : B30-2461-05
- ED1** : 11-MT-92GK
A1 : W02-1174-05
- Q1** : 2SC4081(R, S) or 2SC4116(Y, GR)
Q2 : 2SC2458(Y, GR) or 2SC3311A(Q, R)
Q3 : 2SA1048(Y, GR) or 2SA1309A(Q, R)

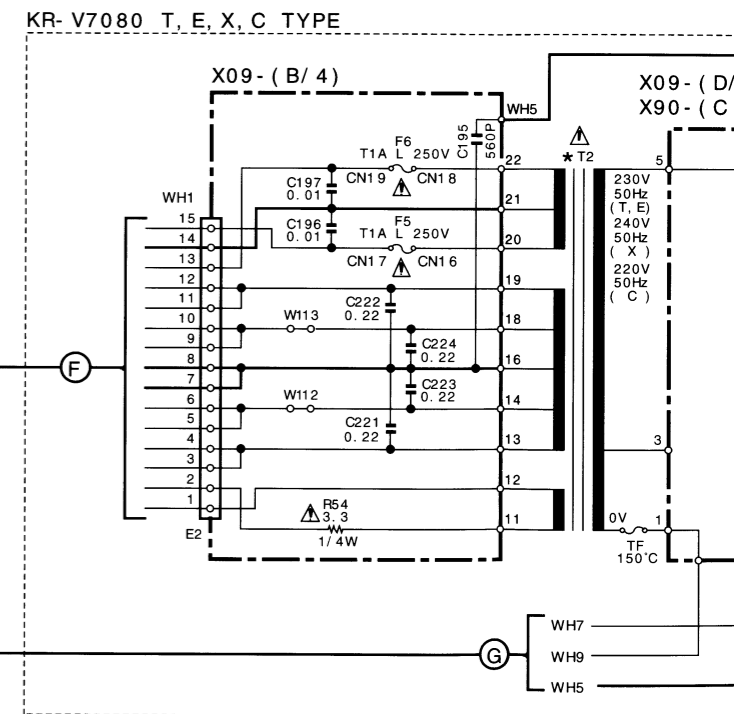
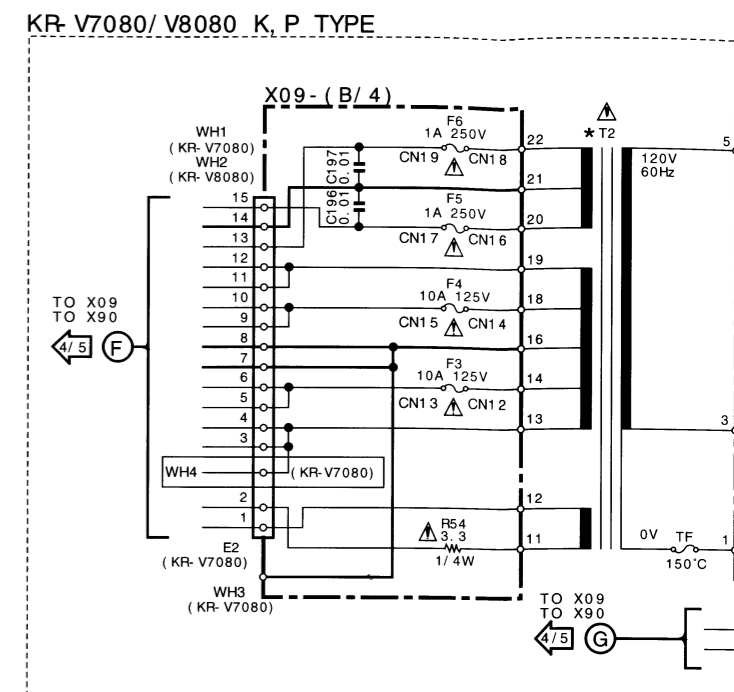

X14-41XX-XX(A/6), (C/6)
X90-

MODEL NAME	DESTINATION COUNTRY	ABB.	UNIT NO.	D29	D31	D16 Q3	R36	R37	(A)	C131 C132	C133
KR-V7080	U. S. A.	K	20-10	NO	NO	NO	NO	NO	NO	NO	NO
	CANADA	P	20-10	NO	NO	NO	NO	NO	NO	NO	NO
	AUSTRALIA	X	20-71	YES	YES	NO	NO	NO	NO	NO	NO
KR-V8080	U. S. A.	K	20-11	NO	NO	NO	NO	NO	NO	NO	NO
	CANADA	P	20-11	NO	NO	NO	NO	NO	NO	NO	NO
	GENERAL MARKET CHINA	M	20-21	YES	NO	YES	YES	YES	NO	YES	YES
KR-V7080	ENGLAND	T	32-70	YES	NO	NO	NO	NO	YES	YES	YES
	EUROPE	E	32-70	YES	NO	NO	NO	NO	YES	YES	YES

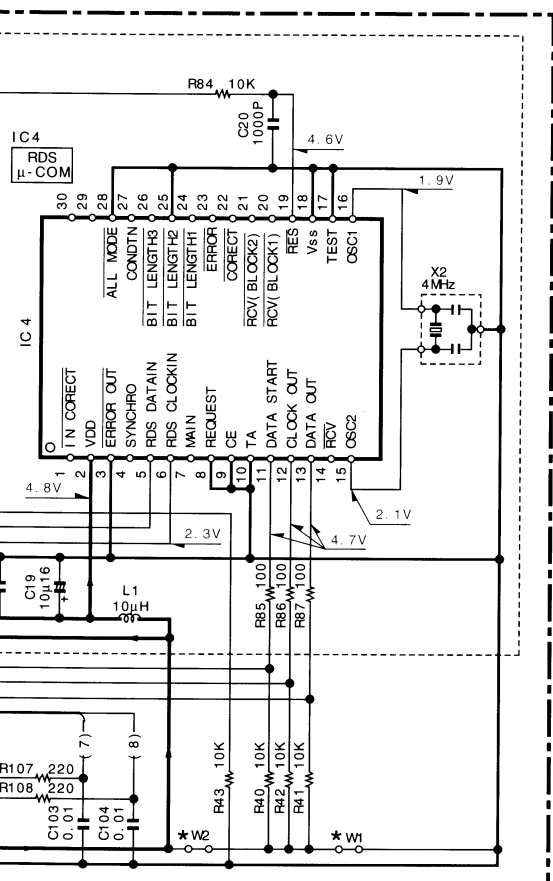
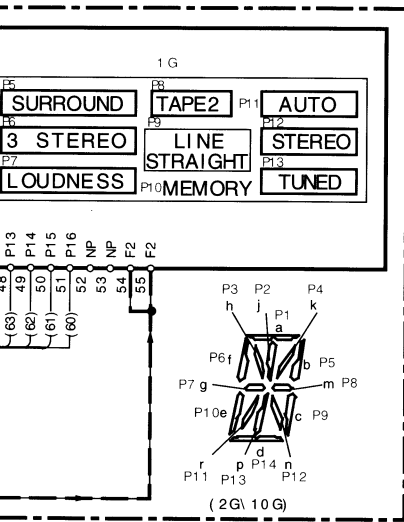

KR-V7080/V8080 K, P TYPE

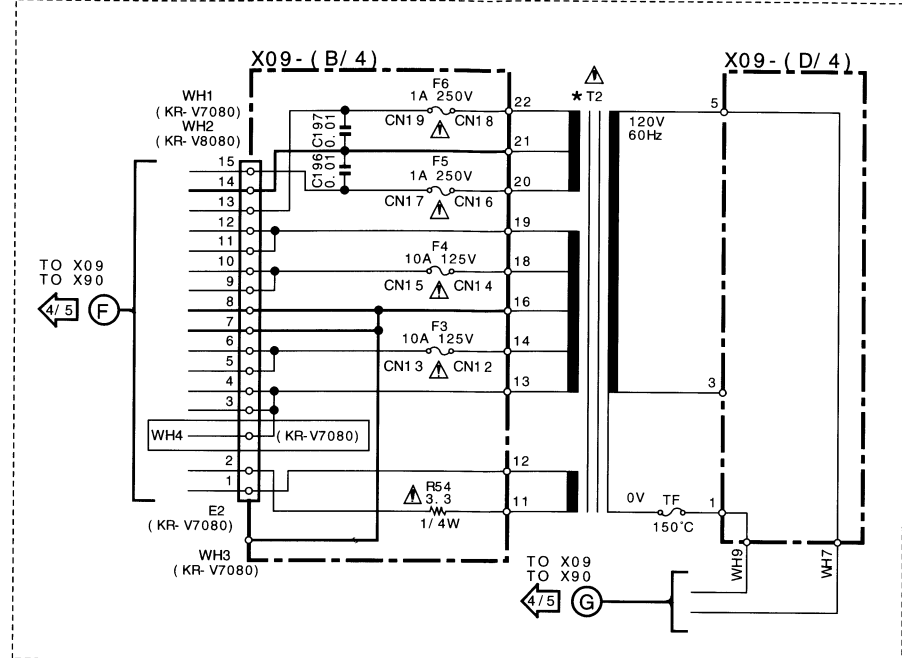

KR-V7080 T, E, X, C TYPE

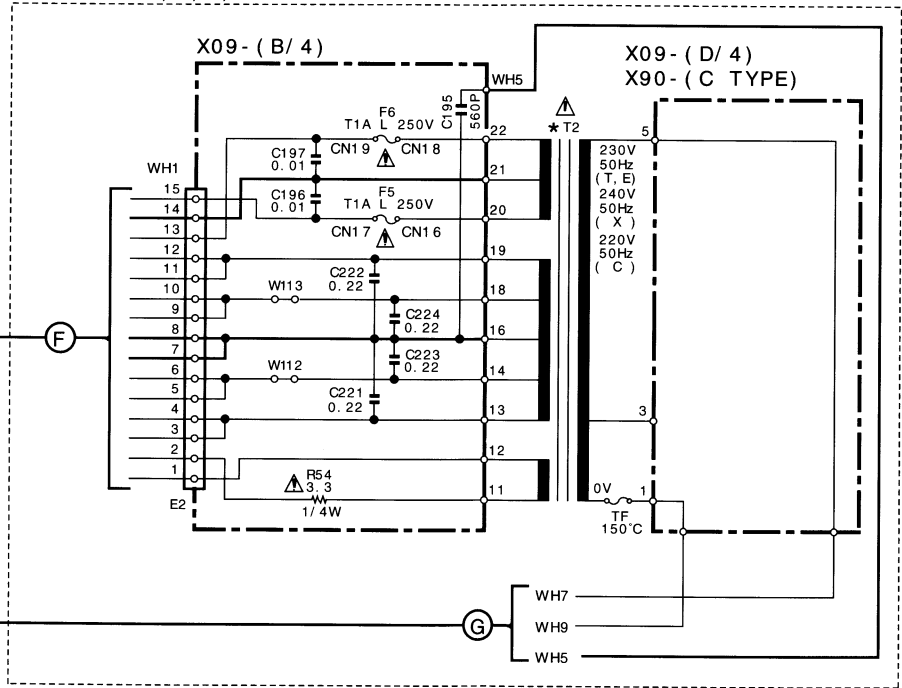

KR-V7080 M, Y TYPE

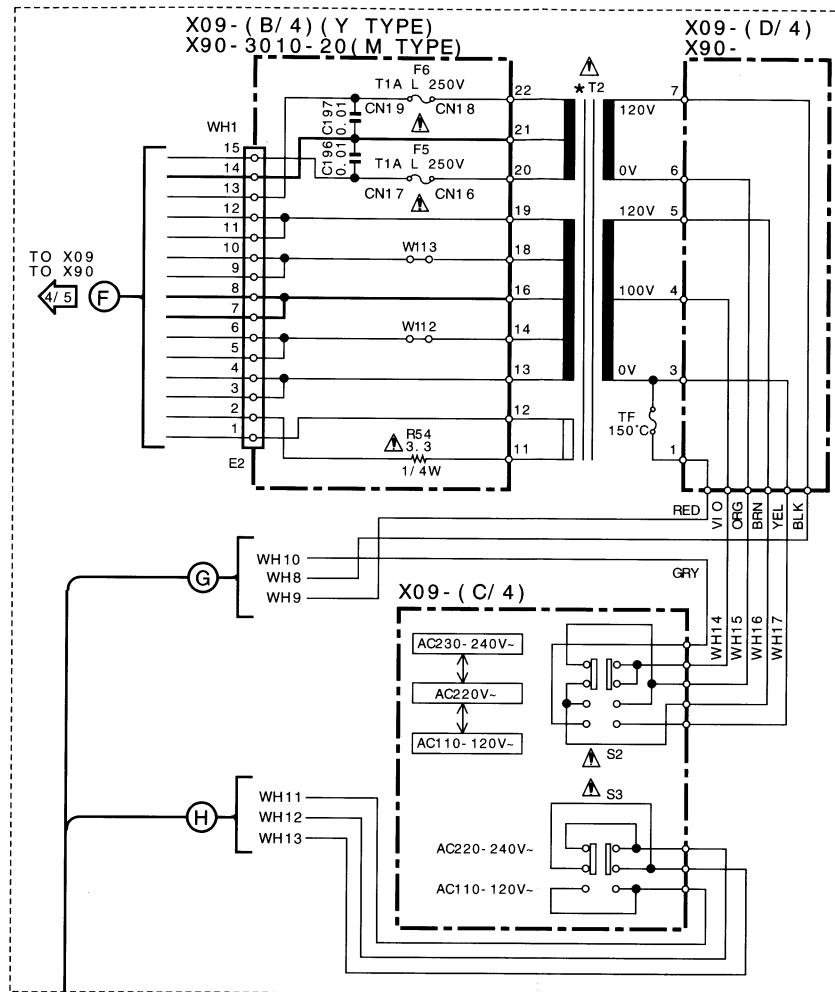

X09-(B/4) (C/4)
X90-(C, M TYPE)

MODEL NAME	DESTINATION COUNTRY	ABB.	T2
KR-V7080	U. S. A. CANADA	K P	L07-2059-05
	AUSTRALIA	X	L07-2061-05
	PX	Y	L07-2060-05
	GENERAL MARKET CHINA	M C	L07-2146-05
	ENGLAND EUROPE	T E	L07-2062-05
KR-V8080	U. S. A. CANADA	K P	L07-2063-05

CAUTION: For continued safety, replace safety critical components only with manufacturer's recommended parts (refer to parts list). Δ indicates safety critical components. For continued protection against risk of fire, replace only with same type and rating fuse(s). To reduce the risk of electric shock, leakage-current or resistance measurements shall be carried out (exposed parts are acceptably insulated from the supply circuit) before the appliance is returned to the customer.

The DC voltage is an actual reading measured with a high impedance type voltmeter as the AM/FM signal generator is specified to the conditions as shown in the list below. The measurement value may vary depending on the measuring instruments used or on the product. The value shown in () is actual reading measured in the AM mode.

X14-41XX-XX(A/6), (C/6)
X90-

MODEL NAME	DESTINATION COUNTRY	ABB.	UNIT NQ	D29	D31	D16 Q3	R36	R37	(A)	C131 C132	C133	S2, 3, 4	W1	W2	L3	L4
KR-V7080	U. S. A. CANADA	K P	20-10	NO	NO	NO	NO	NO		NO	NO	NO	YES	NO	NO	NO
	AUSTRALIA	X	20-71	YES	YES											
	PX	Y														
	GENERAL MARKET CHINA	M C	20-21	YES	NO	YES	YES	YES								YES
	ENGLAND EUROPE	T E	32-70		YES					YES	YES	YES	NO	YES	YES	
KR-V8080	U. S. A. CANADA	K P	20-11	NO	NO	NO	NO	NO		NO	NO	NO	YES	NO	NO	NO

- D1 : RD6.2ES(B2) or HZS6.2N(B2)
- D2, 3, 6, 7, 9-14, 32-35 : 1SS133 or HSS104
- D4, 8 : MA111
- D16, 21-31 : 1SS131 or HSS104A
- D17-19 : B30-2461-05
- ED1 : 11-MT-92GK
- A1 : W02-1174-05



EXPLODED VIEW (UNIT)

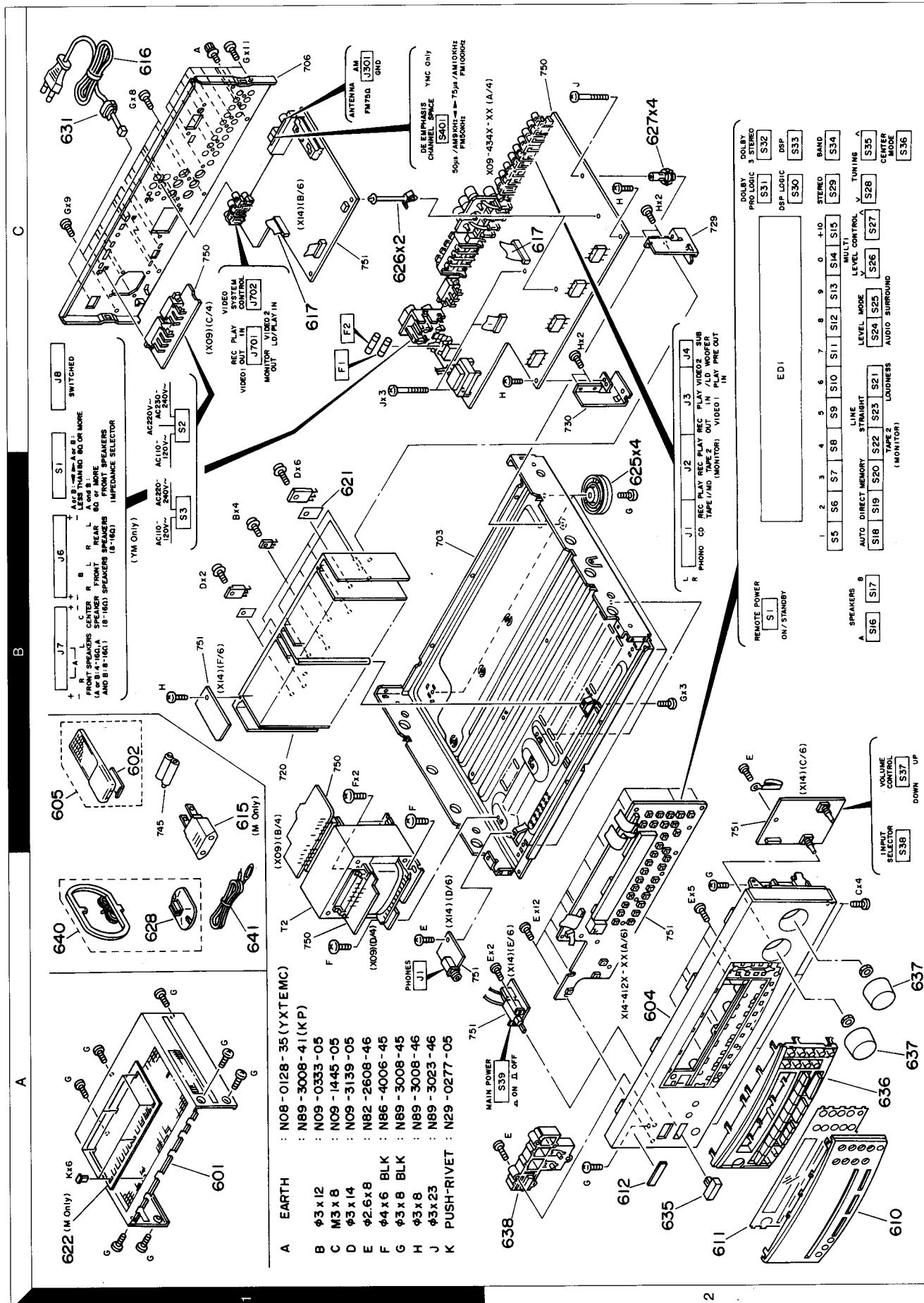

Parts with the exploded numbers larger than 700 are not supplied.

PARTS LIST

2
 * New Parts
 Parts without **Parts No.** are not supplied.
 Les articles non mentionnés dans le **Parts No.** ne sont pas fournis.
 Teile ohne **Parts No.** werden nicht geliefert.

Ref. No	Add-ress	New Parts	Parts No.	Description	Desti-nation	Re-marks
-	-	**	H10-7127-12	POLYSTYRENE FOAMED FIXTURE (R)	MC	
-	-	**	H10-7128-12	POLYSTYRENE FOAMED FIXTURE (L)	T	
-	-	**	H10-7129-12	POLYSTYRENE FOAMED FIXTURE (R)	T	
-	-	*	H13-0223-04	CARTON BOARD	X	KPYXE
-	-	*	H25-0232-04	PROTECTION BAG (235X350X0.03)	MC	
-	-	*	H25-0232-04	PROTECTION BAG (235X350X0.03)	T	
-	-	*	H25-0651-04	PROTECTION BAG (0232 PRINTED)		
-	-	*	H25-0661-04	PROTECTION BAG		
625	2B	*	J02-1148-13	FOOT (D=46, H=14.5)		
626	1C	*	J19-3385-05	UNIT HOLDER		
627	2C	*	J19-3731-04	UNIT HOLDER		
628	1A	*	J19-3645-05	LOOP ANTENNA STAND		
631	1C	*	J42-0083-05	POWER CORD BUSHING		
-	-	*	J19-2808-05	HOLDER	MC	
-	-	*	J61-0098-05	WIRE BAND		
-	-	*	J61-0307-05	WIRE BAND		
635	2A	*	K27-2176-04	KNOB (MAIN POWER)		
636	2A	*	K29-6246-12	KNOB (INPUT SEL/VOLUME)	KPYXMC	
637	2A	*	K29-6247-04	KNOB (REMOTE POWER)	TE	
638	2A	*	K29-6282-02	KNOB (REMOTE POWER)		
638	2A	*	K29-6284-02	KNOB (REMOTE POWER)		
T2	1A	*	L07-2059-05	POWER TRANSFORMER	KP	7
T2	1A	*	L07-2060-05	POWER TRANSFORMER	Y	
T2	1A	*	L07-2061-05	POWER TRANSFORMER	X	
T2	1A	*	L07-2062-05	POWER TRANSFORMER	TE	
T2	1A	*	L07-2063-05	POWER TRANSFORMER	KP	8
T2	1A	*	L07-2142-05	POWER TRANSFORMER	C	
T2	1A	*	L07-2146-05	POWER TRANSFORMER	M	
640	1A	*	T90-0195-05	LOOP ANTENNA		
641	1A	*	T90-0810-05	LEAD WIRE ANTENNA		

AUDIO UNIT (X09-434X-XX)

Ref. No	Add-ress	New Parts	Parts No.	Description	Desti-nation	Re-marks
C1.2	-	*	CC45FSL1H390J	CERAMIC	KPYXMC	
C3.4	-	*	CE04KWI1H100Q	ELECTRO	J	50WV
C5.6	-	*	CC45FSL1H221J	CERAMIC	J	10WV
C7.8	-	*	CE04KWI1A101M	ELECTRO	K	
C9.10	-	*	CK45FBI1H102K	CERAMIC		
C11.12	-	*	CQ93FMG1H123J	MYLAR	J	
C13.14	-	*	CQ93FMG1H392J	MYLAR	J	
C15.16	-	*	CE04KWI1V4R7M	ELECTRO	J	35WV
C17	-	*	CE04DW1V102M	ELECTRO	J	1000UF
C18	-	*	CE04DW1V471M	ELECTRO	J	470UF
C19.20	-	*	CK45FE2H103P	CERAMIC	P	
C21.22	-	*	C91-0749-05	CERAMIC	K	
C23.24	-	*	C91-0749-05	CERAMIC	K	
C25.26	-	*	C91-0749-05	CERAMIC	K	
C27.28	-	*	C91-0749-05	CERAMIC	K	
C29.30	-	*	C91-0749-05	CERAMIC	K	
C31.32	-	*	C91-0749-05	CERAMIC	K	
C33.36	-	*	CQ93FMG1H102J	MYLAR	K	
C38	-	*	CE04KWIJ221M	ELECTRO	J	63WV
C39.40	-	*	CK45FBI1H102K	CERAMIC	K	1000PF
C41.42	-	*	CE04KWI1E470M	ELECTRO	K	47UF

L : Scandinavia
 Y : PX(Far East, Hawaii)
 Y : AAFFES(Europe)
 K : USA
 T : Europe
 X : Australia
 P : Canada
 E : Europe
 M : Other Areas
 C : China
 7 : KR-V7080
 8 : KR-V8080
 Δ indicates safety critical components.

1
 * New Parts
 Parts without **Parts No.** are not supplied.
 Les articles non mentionnés dans le **Parts No.** ne sont pas fournis.
 Teile ohne **Parts No.** werden nicht geliefert.

Ref. No	Add-ress	New Parts	Parts No.	Description	Desti-nation	Re-marks
601	1A	*	A01-3269-01	METALLIC CABINET	KPY	7
602	1B	*	A09-0169-08	BATTERY COVER	XMC	7
604	2A	*	A60-0791-11	PANEL	TE	7
604	2A	*	A60-0792-11	PANEL		
604	2A	*	A60-0793-11	PANEL		
604	2A	*	A60-0794-11	PANEL	KPYXMC	8
605	1B	*	A70-1042-05	REMO-CON ASSY (RC-R0803)	TE	
605	1B	*	A70-1043-05	REMO-CON ASSY (RC-R0803)		
610	2A	*	B10-2170-02	FRONT GLASS	KPYXMC	
610	2A	*	B10-2253-02	FRONT GLASS	TE	
611	2A	*	B11-0294-02	COLOR FILTER		
612	2A	*	B43-0302-04	KENWOOD BADGE	KY	
-	-	*	B46-0092-43	WARRANTY CARD		
-	-	*	B46-0096-53	WARRANTY CARD	X	
-	-	*	B46-0121-33	WARRANTY CARD	P	
-	-	*	B46-0197-00	QUESTIONNAIRE CARD	K	
-	-	*	B46-0310-03	WARRANTY CARD	TE	
-	-	*	B46-0326-03	WARRANTY CARD	C	
-	-	*	B58-0964-13	CAUTION CARD (CAUTION UL)	KY	
-	-	*	B58-0965-13	CAUTION CARD (TX TYPE PL)	XT	
-	-	*	B58-0966-13	CAUTION CARD (ELM TYPE PL)	EMC	
-	-	*	B58-0967-03	CAUTION CARD (P TYPE PL)	P	
-	-	*	B58-0968-04	CAUTION CARD	Y	
-	-	*	B59-1104-00	SERVICE DIRECTORY	Y	KPYXMC
-	-	*	B60-2485-00	I.MANUAL (KR-V7080/V8080 EN)	T	
-	-	*	B60-2486-00	I.MANUAL (KR-V7080 EN)	P	
-	-	*	B60-2487-00	I.MANUAL (KR-V7080/V8080 FR)	E	
-	-	*	B60-2488-00	I.MANUAL (KR-V7080 FR/D)	E	
-	-	*	B60-2489-00	I.MANUAL (KR-V7080 IT/SP)	E	
-	-	*	B60-2490-00	I.MANUAL (KR-V7080 SP)	M	
-	-	*	B60-2491-00	I.MANUAL (KR-V7080 G)	E	
-	-	*	B60-2492-00	I.MANUAL (KR-V7080 C)	MC	
-	-	*	B60-2493-00	I.MANUAL (KR-V7080 TAIWAN)	M	
615	1B	*	E03-0115-05	AC PLUG ADAPTER	M	
616	1C	*	E30-2592-15	AC POWER CORD	M	
616	1C	*	E30-2739-05	AC POWER CORD	M	
616	1C	*	E30-2787-05	AC POWER CORD	Y	
616	1C	*	E30-2788-05	AC POWER CORD	E	
616	1C	*	E30-2790-05	AC POWER CORD	X	
616	1C	*	E30-2791-05	AC POWER CORD	T	
616	1C	*	E30-2825-05	AC POWER CORD	C	
617	1C,2C	*	E35-1319-05	FLAT CABLE(27P/X09CN2-X14CN503)		
621	1B	*	F20-1322-15	INSULATING BOARD	M	8
622	1A	*	F20-1472-03	INSULATING BOARD		
-	-	*	H50-1736-04	ITEM CARTON CASE	KPYXE	7
-	-	*	H50-1749-04	ITEM CARTON CASE	M	7
-	-	*	H50-1750-04	ITEM CARTON CASE	T	7
-	-	*	H50-1751-04	ITEM CARTON CASE	C	7
-	-	*	H50-1752-04	ITEM CARTON CASE		
-	-	*	H10-7126-12	POLYSTYRENE FOAMED FIXTURE (L)	KPYXE	
-	-	*	H10-7126-12	POLYSTYRENE FOAMED FIXTURE (L)	MC	
-	-	*	H10-7127-12	POLYSTYRENE FOAMED FIXTURE (R)	KPYXE	

L : Scandinavia
 Y : PX(Far East, Hawaii)
 Y : AAFFES(Europe)
 K : USA
 T : Europe
 X : Australia
 P : Canada
 E : Europe
 M : Other Areas
 C : China
 7 : KR-V7080
 8 : KR-V8080
 Δ indicates safety critical components.

PARTS LIST

4

* New Parts
Parts without **Parts No.** are not supplied.
Les articles non mentionnés dans le **Parts No.** ne sont pas fournis.
Teile ohne **Parts No.** werden nicht geliefert.

Ref. No	Add-ress	New Parts	Parts No.	Description	Defini-tion	Re-marks
C146			CC45FSL1H101J	100PF		
C147,148			CC45FSL1H221J	220PF	TE	
C149,150			CE04KW1A470M	47UF		
C151,152			CC45FSL1H680J	68PF		
C153			CE04KW2A070M	1.0UF		
C155-158			CK45FB1H152K	1500PF		
C159,160			CC45FSL1H020C	2.0PF		
C161,162			CC45FSL2H680J	68PF		
C165-168			CK45FF1H103Z	0.010UF		
C171,172			CQ93FMG1H104J	0.10UF		
C173			CE04KW0J221M	220UF		8
C174			CE04KW1V47R7M	4.7UF		
C178,179			CQ93FMG1H382J	3900PF		7
C178,179			CQ93FMG1H822J	8200PF		
C181			CK45FF1H103Z	0.010UF		
C182			CE04KW1E101M	100UF		
C184			CE04KW1A470M	4.7UF		
C185			CE04KW1V47R7M	4.7UF		
C186			CK45FF1H103Z	0.010UF	KPTE	
C187-192			CQ93FMG1H102J	1000PF		8
C195			CK45FB1H561K	560PF		
C196,197			CK45FF1H103Z	0.010UF		
C201-204			CK45FB1H471J	470PF		
C205			CQ93FMG1H471J	470PF		
C215,216			CQ93FMG1H102J	1000PF		8
C221-224			C91-1480-05	0.22UF		
C225,226			CC45FSL2H121J	120PF		8
C225,226			CC45FSL2H470J	47PF		7
C227			CC45FSL2H330J	33PF		
C231,232			CQ93FMG1H102J	1000PF		8
C233			CE04HW1E100M	10UF		
C238			CE04KW1H2R2M	2.2UF		
C239-242			CQ93FMG1H104J	0.10UF		
C243,244			CQ93FMG1H562J	5600PF		
C251,252			CE04KW1H2R2M	2.2UF		
C253			CE04KW1C220M	22UF		
C254			CE04KW1C101M	100UF		
C255			CQ93FMG1H103J	0.010UF		8
C256-259			CQ93FMG1H101K	100PF		8
C261,262			CF92FV1H105J	1.0UF		
C263,264			CQ93FMG1H101K	100PF		8
C271			CE04KW1C470M	47UF		
C272			CQ93FMG1H102J	1000PF		8
C343,344			CC45FSL1H221J	220PF		
C345			CF92FV1H224J	0.22UF		
C346			CF92FV1H684J	0.68UF		
C347			CQ93FMG1H101K	100PF		8
C351,352			CE04KW1H2R2M	2.2UF		
C353			CE04KW1H100M	10UF		
C354			CE04KW1C470M	47UF		
C355			CQ93FMG1H101K	100PF		8
C357			CQ93FMG1H103J	0.010UF		8
CN1			E40-4609-05			
CN2			E40-4914-05			

L: Scandinavia K: USA P: Canada
 Y: PX(Far East, Hawaii) T: Europe E: Europe
 X: AAFES(Europe) M: Other Areas
 C: China 7: KR-V7080
 8: KR-V8080
 Δ indicates safety critical components.

5

* New Parts
Parts without **Parts No.** are not supplied.
Les articles non mentionnés dans le **Parts No.** ne sont pas fournis.
Teile ohne **Parts No.** werden nicht geliefert.

Ref. No	Add-ress	New Parts	Parts No.	Description	Defini-tion	Re-marks
C43-45			CE04KW1C470M	47UF		
C46			CE04KW1H100M	10UF		7
C47,48			C90-3536-05	6800UF		8
C47,48			C90-3602-05	1200UF		
C49		*	CQ93FMG1H102J	1000PF		8
C50			CE04HW1A220M	22UF		
C51			CE04KW1C220M	22UF		
C52,53			CE04KW1C470M	47UF		
C54-56			CK45FE2H103P	0.010UF		
C57			CE04KW1C470M	47UF		
C58			CK45FB1H102K	1000PF		
C59			CQ93FMG1H102J	1000PF		8
C60			CE04KW1C470M	47UF		
C61			CE04KW2A100M	10UF		
C62			CE04KW2A101M	100UF		
C63,64			CE04KW1H010M	1.0UF		
C65			CE04KW1V47R7M	4.7UF		
C66			CQ93FMG1H102J	1000PF		8
C67,68			CE04KW1H2R2M	2.2UF		
C69,70			CQ93FMG1H102J	1000PF		8
C71,72			CK45FB1H102K	1000PF	TE	7
C71,72			CK45FB1H471K	470PF	KPYXMC	7
C71,72			CQ93FMG1H471J	470PF		8
C73,76			CE04KW1C220M	22UF		
C77			CK45FB1H471K	470PF		
C78			CQ93FMG1H102J	1000PF		8
C80,81			CK45FF1H103Z	0.010UF		
C82,83			CC45FSL1H221J	220PF		
C84			C91-0749-05	220PF		
C86			CE04KW1H2R2M	2.2UF		
C87,88			CK45FE2H103P	0.010UF		8
C89,90			CE04KW1H010M	1.0UF		
C91-94			CQ93FMG1H682J	6800PF	TE	
C95,96			CK45FE1H103Z	0.010UF	TE	
C98			CK45FB1H102K	1000PF	TE	
C101,102			CE04KW1H010M	1.0UF		
C103,104			CQ93FMG1H102J	1000PF		
C109,110			CE04KW1A101M	100UF		
C111,112			CC45FSL1H101J	100PF		
C113,114			CE04KW2A010M	1.0UF		
C115,116			CK45FB1H471K	470PF	TE	
C119,120			CC45FSL1H120J	12PF	KPYXMC	
C119,120			CC45FSL1H180J	18PF		
C121,122			CC45FSL2H470J	47PF	KPYXMC	
C121,122			CC45FSL2H680J	68PF	TE	
C125-128			CK45FE1H103Z	0.010UF		
C129			CQ93FMG1H123J	0.012UF		7
C129			CQ93FMG1H562J	5600PF		8
C131,132			CQ93FMG1H104J	0.10UF		
C133,134			CQ93FMG1H183J	0.018UF		
C139			CQ93FMG1H123J	0.012UF		
C140			CK45FB1H102K	1000PF	TE	
C141,142			CE04KW1H010M	1.0UF		
C143,144			CQ93FMG1H102J	1000PF		
C145			CK45FB1H471K	470PF		

L: Scandinavia K: USA P: Canada
 Y: PX(Far East, Hawaii) T: Europe E: Europe
 X: AAFES(Europe) M: Other Areas
 C: China 7: KR-V7080
 8: KR-V8080
 Δ indicates safety critical components.

PARTS LIST

6

* New Parts
Parts without **Parts No.** are not supplied.
Les articles non mentionnés dans le **Parts No.** ne sont pas fournis.
Teile ohne **Parts No.** werden nicht geliefert.

Ref. No	Add-ress	New Parts	Parts No.	Description	Desti-nation	Re-marks
Δ R234			R92-1769-05	CARBON		
Δ R374			RD14NB2E820J	TRIMMING POT. (1K ADJUSTMENT)		
Δ VR1-4			R12-1616-05			
				3.3M j 1/2W		
				82 j 1/4W		
Δ K1-3			S76-0038-05	MAGNETIC RELAY (SP RELAY)		
Δ K1-3			S76-0045-05	MAGNETIC RELAY (SP RELAY)		
Δ K5			S76-0009-05	MAGNETIC RELAY		
Δ K5			S76-0044-05	MAGNETIC RELAY		
Δ S1			S31-2136-05	SLIDE SWITCH (IMPEDANCE SEL)		
Δ S2			S31-2322-05	SLIDE SWITCH (120-/220-/240-)		YM
Δ S3			S62-0001-05	SLIDE SWITCH (120-/240-)		YM
Δ D1			RBV-602LFA	DIODE		
Δ D3-8			S5688B	DIODE		
Δ D3-8			ISR139-100	DIODE		
Δ D9			RD4.7ES(B2)	ZENER DIODE		
Δ D9			RD4.7ES(B2)	ZENER DIODE		
Δ D10			HSS104	DIODE		
Δ D10			1SS133	DIODE		
Δ D11			HZS6.2N(B2)	ZENER DIODE		
Δ D11			RD6.2ES(B2)	ZENER DIODE		
Δ D12			HZS8.2N(B2)	ZENER DIODE		
Δ D12			RD8.2ES(B2)	ZENER DIODE		
Δ D13_14			HZS16N(B2)	ZENER DIODE		
Δ D13_14			RD16ES(B2)	ZENER DIODE		
Δ D19-20			HSS104	DIODE		
Δ D15-20			1SS133	DIODE		
Δ D21-24			HSS104A	DIODE		
Δ D21-24			1SS131	DIODE		
Δ D25			HZS5.1N(B2)	ZENER DIODE		
Δ D25			RD5.1ES(B2)	ZENER DIODE		
Δ D29			HSS104A	DIODE		
Δ D29			1SS131	DIODE		
Δ D30			HZS5.1N(B2)	ZENER DIODE		
Δ D30			RD5.1ES(B2)	ZENER DIODE		
Δ D31_32			S5688B	DIODE		
Δ D31_32			ISR139-100	DIODE		
Δ D48			HSS104	DIODE		
Δ D48			1SS133	DIODE		
Δ D49			HSS104A	DIODE		
Δ D49			1SS131	DIODE		
Δ D50-53			S5688B	DIODE		
Δ D50-53			ISR139-100	DIODE		
Δ D54			HZS6.2N(B2)	ZENER DIODE		
Δ D54			RD6.2ES(B2)	ZENER DIODE		
Δ D55_56			HSS104A	DIODE		
Δ D55_56			1SS131	DIODE		
Δ D57			HZS2.7N(B2)	ZENER DIODE		
Δ D57			RD2.7ES(B2)	ZENER DIODE		
Δ D59			HSS104	DIODE		
Δ D59			1SS133	DIODE		
Δ D64			HSS104A	DIODE		
Δ D64			1SS131	DIODE		
Δ D71_72			HZS8.2N(B2)	ZENER DIODE		
Δ D71_72			RD8.2ES(B2)	ZENER DIODE		
Δ D73			HZS10N(B)	ZENER DIODE		

L : Scandinavia K : USA P : Canada C : China 7 : KR-V7080
 Y : PY(Far. East, Hawaii) T : Europe E : Europe 8 : KR-V8080
 Y : AAFES(Europe) X : Australia M : Other Areas Δ indicates safety critical components.

5

* New Parts
Parts without **Parts No.** are not supplied.
Les articles non mentionnés dans le **Parts No.** ne sont pas fournis.
Teile ohne **Parts No.** werden nicht geliefert.

Ref. No	Add-ress	New Parts	Parts No.	Description	Desti-nation	Re-marks
Δ CN4			E40-4245-05	PIN ASSY (3P)		
Δ J1-3			E63-0139-15	PHONO JACK (6P)		
Δ J4			E63-0164-05	PHONO JACK (SUB WOOFER)		
Δ J6			E70-0065-05	LOCK TERMINAL BOARD (F/R SP)		
Δ J7			E70-0049-05	SCREW TERMINAL BOARD (F/C SP)		
Δ J7			E70-0064-05	SCREW TERMINAL BOARD (F/C SP)		
Δ J8			E03-0148-05	AC OUTLET		
Δ J8			E03-0149-05	AC OUTLET		KPY
Δ J8			E03-0310-05	AC OUTLET		EM
Δ J8			E03-0325-05	AC OUTLET		T
Δ J8			E03-0330-05	AC OUTLET		X
Δ W212,213			E29-1614-03	LEAD PLATE		
Δ W214			E29-1615-04	LEAD PLATE		
Δ W215,216			E29-1616-04	LEAD PLATE		
Δ F1			F05-3121-05	FUSE (SEMKO)		
Δ F1			F05-0078-05	FUSE (5X20)		YXTEMC
Δ F2			F05-2525-05	FUSE (SEMKO)		
Δ F2			F05-3121-05	FUSE (SEMKO)		E
Δ F3,4			F05-0078-05	FUSE (5X20)		YM
Δ F5,6			F04-1026-05	FUSE (UL)		KP
Δ F5,6			F06-1022-05	FUSE (SEMKO)		YXTEMC
Δ CN7_8			J13-0075-05	FUSE CLIP		
Δ CN10_11			J13-0075-05	FUSE CLIP		
Δ CN12-15			J13-0075-05	FUSE CLIP		
Δ CN16-19			J13-0075-05	FUSE CLIP		
Δ J9			J11-0809-05	WIRE CLAMPER		
Δ J10_11			J11-0809-05	WIRE CLAMPER		
Δ T1			L07-0864-05	POWER TRANSFORMER		
Δ T1			L07-0865-05	POWER TRANSFORMER		
Δ T1			L07-0866-05	POWER TRANSFORMER		
Δ T1			L07-0867-05	POWER TRANSFORMER		
Δ T1			L07-2114-05	POWER TRANSFORMER		
Δ CP1-3			R90-0840-05	RD		
Δ CP4			R90-0186-05	MULTI-COMP		
Δ R27			RD14NB2E470J	0.22		
Δ R30			RS14KB3D822J	0.47X2		
Δ R41			RD14NB2E101J	47		
Δ R42			RD14NB2E180J	100		
Δ R43-45			RS14KB3D331J	18		
Δ R49			RD14NB2E682J	330		
Δ R54			RD14NB2E3R3J	6.8K		
Δ R55			RD14NB2E470J	3.3		
Δ R99_100			RD14NB2E470J	47		
Δ R115-118			RD14NB2E221J	47		
Δ R123,124			RD14NB2E121J	220		
Δ R133-136			RD14NB2E220J	120		
Δ R137,138			RD14NB2E332J	22		
Δ R143,144			RS14KB3D4R7J	3.3K		
Δ R165-168			RD14NB2E221J	4.7		
Δ R173,174			RD14NB2E121J	220		
Δ R183-186			RD14NB2E220J	120		
Δ R187,188			RD14NB2E332J	22		
Δ R193,194			RS14KB3D4R7J	3.3K		

L : Scandinavia K : USA P : Canada C : China 7 : KR-V7080
 Y : PY(Far. East, Hawaii) T : Europe E : Europe 8 : KR-V8080
 Y : AAFES(Europe) X : Australia M : Other Areas Δ indicates safety critical components.

KR-V7080/V8080

PARTS LIST

8
 * New Parts
 Parts without **Parts No.** are not supplied.
 Les articles non mentionnés dans le **Parts No.** ne sont pas fournis.
 Teile ohne **Parts No.** werden nicht geliefert.

Ref. No	Add-ress	New Parts	Parts No.	Description	Desti-nation	Re-marks
C105,106		*	2SC4137F50(V,W)	TRANSISTOR		
C107,108		*	2SD2389	TRANSISTOR		
C109,110		*	2SB1559	TRANSISTOR		
C111,112		*	2SC4137F50(V,W)	TRANSISTOR		
DISPLAY UNIT (X14-4120-XX/X14-4132-XX)						
D17-19			B30-2461-05	LED(RED,5 1/4)		
C1			C90-3253-05	ELECTRO		50WV
C2			CE04KW1H010M	ELECTRO		50WV
C3			C90-1827-05	ELECTRO		5.5WV
C4			CE04KW1A221M	ELECTRO		10WV
C5-6			C90-3242-05	ELECTRO		35WV
C7			CE04KW1C330M	ELECTRO		16WV
C8-10			C91-0769-05	CERAMIC		K
C11			CC73FCH1H470J	CHIP C		J
C12			CE04KW1H2R2M	ELECTRO		50WV
C13			CC45FSL1H331J	CERAMIC		J
C14			CK73FB1H103K	CHIP C		K
C15			CC73FCH1H220J	CHIP C		J
C16			CC45FSL1H561J	CERAMIC		J
C17			CE04KW1C100M	ELECTRO		16WV
C18			CK73FB1H103K	CHIP C		K
C19			CE04KW1C100M	ELECTRO		16WV
C20			CK73FB1H102K	CHIP C		K
C21			C91-1488-05	MF		250VAC
C22,23			CK45FF1H103Z	CERAMIC		Z
C24			CK73FB1E473K	CHIP C		K
C101-104			CO93FMG1H103J	MYLAR		J
C105			CK73FB1H102K	CHIP C		K
C131,132			CK45FB1H561K	CERAMIC		K
C133			CK45FF1H23Z	CERAMIC		Z
C200			CK45FF1H473Z	CERAMIC		Z
C301,302			CK73FB1H103K	CHIP C		K
C303			CE04KW1C100M	ELECTRO		16WV
C304			CE04KW1A470M	ELECTRO		10WV
C305			CK73FB1E473K	CHIP C		K
C305			CE04KW1C100M	ELECTRO		16WV
C306			CK73FB1H103K	CHIP C		K
C307			CE04KW1C100M	ELECTRO		16WV
C308			CE04KW1H010M	ELECTRO		10WV
C308			CK73FB1H103K	CHIP C		K
C309			CE04KW1HR47M	ELECTRO		50WV
C310			CE04KW1H2R2M	ELECTRO		50WV
C310			CK73FB1H102K	CHIP C		K
C311			CE04KW1HR47M	ELECTRO		50WV
C311			CE04KW1V4R7M	ELECTRO		35WV
C312			CK73FB1E473K	CHIP C		K
C313			CC73FCH1H220J	CHIP C		J
C313			CE04KW1H010M	ELECTRO		50WV
C314			CE04KW1A101M	ELECTRO		10WV
C314			CE04KW1H2R2M	ELECTRO		50WV
C315			CK73FB1H472K	CHIP C		K
C316			CE04KW1H010M	ELECTRO		50WV
C317,318			CE04KW1C100M	ELECTRO		16WV

L : Scandinavia
 Y : FX(Far East, Hawaii)
 Y : AAFES(Europe)

K : USA
 T : Europe
 X : Australia

P : Canada
 E : Europe
 M : Other Areas

C : China

7 : KR-V7080
 8 : KR-V8080

⚠ indicates safety critical components.

7
 * New Parts
 Parts without **Parts No.** are not supplied.
 Les articles non mentionnés dans le **Parts No.** ne sont pas fournis.
 Teile ohne **Parts No.** werden nicht geliefert.

Ref. No	Add-ress	New Parts	Parts No.	Description	Desti-nation	Re-marks
D73			RD10ES(B)	ZENER DIODE		
D75,76			HZS6.2N(B2)	ZENER DIODE		
D77,78			RD8.2ES(B2)	ZENER DIODE		
D77,78			S5688B	DIODE		
D77,78			1SR139-100	DIODE		
D79			HSS104	DIODE		
D79			1SS133	DIODE		
D80			HZS5.1N(B2)	ZENER DIODE		
D80			RD5.1ES(B2)	ZENER DIODE		
D90			HSS104	DIODE		
D90			1SS133	DIODE		
IC1			NUM4580L-D	IC(OP AMP X2)		
IC2			NUM4565L-D	ANALOGUE IC		
IC3			NUM4560D-D	IC(OP AMP X2)		
IC4			NUJ7312AL	ANALOGUE IC		
IC5			NUJ7311AL	ANALOGUE IC		
IC6			TDAT7315	ANALOGUE IC		
IC7			TDAT7345D	ANALOGUE IC		
Q2			2SC2878(B)	TRANSISTOR		
Q3			2SD2012	TRANSISTOR		
Q4			2SD2061(E,F)	TRANSISTOR		
Q5			2SC2458(Y,GR)	TRANSISTOR		
Q5			2SC3311A(Q,R)	TRANSISTOR		
Q6			2SB1370(E,F)	TRANSISTOR		
Q6			2SB1375	TRANSISTOR		
Q7			2SC2458(Y,GR)	TRANSISTOR		
Q7			2SC3311A(Q,R)	TRANSISTOR		
Q8			2SA1048(Y,GR)	TRANSISTOR		
Q8			2SA1309A(Q,R)	TRANSISTOR		
Q9			2SA1534A(R,S)	TRANSISTOR		
Q10-12			DTC113ZS	DIGITAL TRANSISTOR		
Q10-12			UN4219	TRANSISTOR		
Q14			2SA1048(Y,GR)	TRANSISTOR		
Q14			2SA1309A(Q,R)	TRANSISTOR		
Q15-18			2SC2878(B)	TRANSISTOR		
Q19			DTC124ES	DIGITAL TRANSISTOR		
Q19			UN4212	TRANSISTOR		
Q20			2SC2458(Y,GR)	TRANSISTOR		
Q20			2SC3311A(Q,R)	TRANSISTOR		
Q21-24			2SA992(F,E)	TRANSISTOR		
Q25-28			2SC2631(R,S)	TRANSISTOR		
Q29,30			2SA1123(R,S)	TRANSISTOR		
Q31,32			2SC1845(F,E)	TRANSISTOR		
Q33,36			2SA992(F,E)	TRANSISTOR		
Q37-40			2SC2631(R,S)	TRANSISTOR		
Q41,42			2SA1123(R,S)	TRANSISTOR		
Q43,46			2SC1845(F,E)	TRANSISTOR		
Q47,48			2SA992(F,E)	TRANSISTOR		
Q49,50			2SC2878(B)	TRANSISTOR		
Q63			2SC2003(L,K)	TRANSISTOR		
Q64			2SC3940A(R,S)	TRANSISTOR		
Q90			DTC124ES	DIGITAL TRANSISTOR		
Q90			UN4212	TRANSISTOR		
Q101,102			2SD2222 *5	TRANSISTOR		
Q103,104			2SB1470 *5	TRANSISTOR		

L : Scandinavia
 Y : FX(Far East, Hawaii)
 Y : AAFES(Europe)

K : USA
 T : Europe
 X : Australia

P : Canada
 E : Europe
 M : Other Areas

C : China

7 : KR-V7080
 8 : KR-V8080

⚠ indicates safety critical components.

KR-V7080/V8080

PARTS LIST

17
 * New Parts
 Parts without **Parts No.** are not supplied.
 Les articles non mentionnés dans le **Parts No.** ne sont pas fournis.
 Teile ohne **Parts No.** werden nicht geliefert.

Ref. No	Add-ress	New Parts	Parts No.	Description	Designation	Re-marks
C363			CK73FB1H103K	0.010UF	CHIP C	TE
C364			CE04KW1H010M	1.0UF	ELECTRO	TE
C365			CE04KW1H010M	1.0UF	ELECTRO	KPYXMC
C366			CK73FB1E473K	0.047UF	CHIP C	TE
C366			CK73FB1H102K	1000PF	CHIP C	KPYXMC
C371			CE04KW1C100M	10UF	ELECTRO	KPYXMC
C372			CE04KW1C470M	47UF	ELECTRO	KPYXMC
C403-406			CE04KW1HR47M	0.47UF	ELECTRO	KPYXMC
C407			CK73FB1E473K	0.047UF	CHIP C	KPYXMC
C412			CC73FSL1H101J	100PF	CHIP C	KPYXMC
C414			CK73FB1H681K	680PF	CHIP C	KPYXMC
C415-416			CK73FSL1H101J	100PF	CHIP C	KPYXMC
C421-422			CE04KW1C470M	47UF	ELECTRO	KPYXMC
C425			CQ93FMG1H682J	6800PF	MYLAR	YMC
C438			CQ93FMG1H682J	6800PF	MYLAR	YMC
C482			CC73FSL1H150J	15PF	CHIP C	KPYXMC
C501			CQ93FMG1H223J	0.022UF	MYLAR	
C502			CQ93FMG1H473J	0.047UF	MYLAR	
C503			CE04KW1A221M	220UF	ELECTRO	10WV
C504-507			CE04KW1C100M	10UF	ELECTRO	16WV
C508			CE04KW1A221M	220UF	ELECTRO	10WV
C509-510			CQ93FMG1H104J	0.10UF	MYLAR	J
C511			CE04KW1HR47M	0.47UF	ELECTRO	50WV
C512			CE04KW1V4R7M	4.7UF	ELECTRO	35WV
C513			CE04KW1HR47M	0.47UF	ELECTRO	50WV
C514			CE04KW1V4R7M	4.7UF	ELECTRO	35WV
C515			CF92FV1H154J	0.15UF	MF-C	J
C516			CE04KW1HR3M	3.3UF	ELECTRO	50WV
C517-518			CF92FV1H154J	0.15UF	MF-C	J
C519			CE04KW1HR3M	3.3UF	ELECTRO	50WV
C520			CF92FV1H154J	0.15UF	MF-C	J
C521			CE04KW1V4R7M	4.7UF	ELECTRO	16WV
C522			CE04KW1HR47M	0.47UF	ELECTRO	50WV
C523			CE04KW1V4R7M	4.7UF	ELECTRO	35WV
C524			CE04KW1HR47M	0.47UF	ELECTRO	50WV
C525-526			CQ93FMG1H104J	0.10UF	MYLAR	J
C527			CE04KW1C470M	47UF	ELECTRO	16WV
C528-529			CF92FV1H474J	0.47UF	MF-C	J
C530-531			CE04KW1C100M	10UF	ELECTRO	16WV
C532			CQ93FMG1H681J	680PF	MYLAR	J
C533-535			CE04KW1H010M	1.0UF	ELECTRO	50WV
C536			CE04KW1C100M	10UF	ELECTRO	16WV
C537			CK73FB1H103K	0.010UF	CHIP C	K
C538			CE04KW1H2R2M	2.2UF	ELECTRO	50WV
C539			CE04KW1C100M	10UF	ELECTRO	16WV
C540			CE04KW1HR33M	0.33UF	ELECTRO	50WV
C541			CE04KW1C100M	10UF	ELECTRO	16WV
C542			CE04KW1A221M	220UF	ELECTRO	10WV
C543-544			CE04KW1C100M	10UF	ELECTRO	16WV
C545			CE04KW1HR47M	0.47UF	ELECTRO	50WV
C546			CQ93FMG1H823J	0.082UF	MYLAR	J
C547			CQ93FMG1H832J	3300PF	MYLAR	J
C548			CQ93FMG1H823J	0.082UF	MYLAR	J
C549			CE04KW1A221M	220UF	ELECTRO	10WV
C550			CK73FB1H102K	1000PF	CHIP C	K

L : Scandinavia
 Y : PFI(Far East, Hawaii)
 X : AAFES(Europe)
 K : USA
 T : Europe
 P : Canada
 E : Europe
 M : Other Areas
 C : China
 7 : KR-V7080
 8 : KR-V8080

▲ indicates safety critical components.

9
 * New Parts
 Parts without **Parts No.** are not supplied.
 Les articles non mentionnés dans le **Parts No.** ne sont pas fournis.
 Teile ohne **Parts No.** werden nicht geliefert.

Ref. No	Add-ress	New Parts	Parts No.	Description	Designation	Re-marks
C319-320			CQ93FMG1H273J	0.027UF	MYLAR	TE
C321			CK73FB1H103K	0.010UF	CHIP C	TE
C321			CQ93FMG1H163J	0.016UF	MYLAR	YXMC
C321			CQ93FMG1H243J	0.024UF	MYLAR	KP
C322			CC73FSL1H101J	100PF	CHIP C	TE
C322			CQ93FMG1H163J	0.016UF	MYLAR	YXMC
C323			CQ93FMG1H243J	0.024UF	MYLAR	KP
C323			CE04KW1H010M	1.0UF	ELECTRO	KPYXMC
C323			CE04KW1H2R2M	2.2UF	ELECTRO	TE
C324			CE04KW1H2R2M	2.2UF	ELECTRO	TE
C324			CE04KW1H3R3M	3.3UF	ELECTRO	KPYXMC
C325			CE04KW1C100M	10UF	ELECTRO	KPYXMC
C325			CK73FB1H562K	5600PF	CHIP C	TE
C326			CK73FB1H562K	5600PF	CHIP C	TE
C327			CK73FB1E473K	0.047UF	CHIP C	TE
C328			CC73FSL1H150J	15PF	CHIP C	TE
C328			CE04KW1C100M	10UF	ELECTRO	KPYXMC
C329			CE04KW1H010M	0.1UF	ELECTRO	TE
C330			CE04KW1C470M	47UF	ELECTRO	TE
C331			CE04KW1A470M	47UF	ELECTRO	KPYXMC
C331			CK73FB1E473K	0.047UF	CHIP C	TE
C332			CK73FB1H103K	0.010UF	CHIP C	K
C333			CK73FB1H270J	27PF	CHIP C	J
C334			CK73FB1H220J	22PF	CHIP C	J
C335-336			CC73FSL1H101J	100PF	CHIP C	J
C335-336			CK73FB1H471K	470PF	CHIP C	K
C338			CC73FSL1H101J	100PF	CHIP C	TE
C338			CK73FB1H471K	470PF	CHIP C	KPYXMC
C339			CE04KW1C470M	47UF	ELECTRO	TE
C340			CK73FB1H223K	0.022UF	CHIP C	KPYXMC
C340			CQ93FMG1H223J	0.022UF	NP-ELEC	TE
C341			CE04KW1H2R2M	2.2UF	ELECTRO	TE
C341			CE04KW1H010M	1.0UF	ELECTRO	KPYXMC
C342-343			CK73FB1H103K	0.010UF	CHIP C	TE
C344			CE04KW1A470M	47UF	ELECTRO	TE
C345			CE04KW1C470M	47UF	ELECTRO	TE
C346			CE04KW1H010M	1.0UF	ELECTRO	TE
C347			CK73FB1H103K	0.010UF	CHIP C	TE
C348			CE04KW1H010M	1.0UF	ELECTRO	TE
C349			CK73FB1H103K	0.010UF	CHIP C	TE
C350			CC73FCH1H830J	33PF	CHIP C	TE
C350			C91-0769-05	0.010UF	CERAMIC	KPYXMC
C351			CE04KW1H010M	1.0UF	ELECTRO	KPYXMC
C351			CK73FB1H102K	1000PF	CHIP C	TE
C352			CE04KW1C470M	47UF	ELECTRO	KPYXMC
C352			CK73FB1H102K	1000PF	CHIP C	TE
C353-354			CK73FB1H102K	1000PF	CHIP C	TE
C355			CK73FB1H222K	2200PF	CHIP C	TE
C356			CC73FCH1H060D	6.0PF	CHIP C	TE
C357			CC73FCH1H220J	22PF	CHIP C	D
C358			CK73FB1E473K	0.047UF	CHIP C	J
C359			CK73FB1H102K	1000PF	CHIP C	K
C360			CC73FSL1H101J	100PF	CHIP C	K
C361			C91-0745-05	100PF	CERAMIC	TE
C362			CC45FSL1H020C	2.0PF	CERAMIC	TE

L : Scandinavia
 Y : PFI(Far East, Hawaii)
 X : AAFES(Europe)
 K : USA
 T : Europe
 P : Canada
 E : Europe
 M : Other Areas
 C : China
 7 : KR-V7080
 8 : KR-V8080

▲ indicates safety critical components.

KR-V7080/V8080

PARTS LIST

12

* New Parts
Parts without **Parts No.** are not supplied.
Les articles non mentionnés dans le **Parts No.** ne sont pas fournis.
Teile ohne **Parts No.** werden nicht geliefert.

Ref. No	Add-ress	New Parts	Parts No.	Description	Desti-nation	Re-marks
X301			L77-2159-05	CRYSTAL RESONATOR(7,2MHZ)		
X302			L78-0637-05	RESONATOR (456KHZ)		
X501		*	L78-0290-05	RESONATOR (80MHZ)		
CP1			R90-0492-05	MULTI-COMP		
R1			RK73EB2B101J	CHIP R		1/8W
R3-5			RK73FB2A101J	CHIP R		1/8W
R6			RK73FB2A102J	CHIP R		1/10W
R8			RK73FB2A104J	CHIP R		1/10W
R9			RK73FB2A102J	CHIP R		1/10W
R10 ,11			RK73FB2A103J	CHIP R		1/10W
R15 ,16			RK73FB2A311J	CHIP R		1/10W
R17 ,18			RK73FB2A104J	CHIP R		1/10W
R19 ,20			RD14NB2E221J	RD		1/4W
R22			RD14NB2E100J	RD		1/4W
R23 -27			RK73FB2A102J	CHIP R		1/10W
R28 -30			RK73FB2A103J	CHIP R		1/10W
R38 ,39			RK73FB2A472J	CHIP R		1/10W
R44 ,45			RK73FB2A103J	CHIP R		1/10W
R52			RK73EB2B103J	CHIP R		1/8W
R54			RK73FB2A222J	CHIP R		1/10W
R69 -72			RK73FB2A101J	CHIP R		1/10W
R75 -77			RK73FB2A101J	CHIP R		1/10W
R80			RK73FB2A222J	CHIP R		1/10W
R82 ,83			RK73FB2A223J	CHIP R		1/10W
R111,112			RK73FB2A683J	CHIP R		1/10W
R113,114			RK73EB2B683J	CHIP R		1/8W
R115-120			RK73FB2A683J	CHIP R		1/10W
R121			RK73EB2B683J	CHIP R		1/8W
R122-125			RK73FB2A683J	CHIP R		1/10W
R131,132			RS14KB3D561J	FL-PROOF RS		2W
R301			RK73FB2A681J	CHIP R		1/10W
R302			RK73FB2A332J	CHIP R		1/10W
R303			RK73FB2A331J	CHIP R		1/10W
R304			RK73FB2A100J	CHIP R		1/10W
R304			RK73FB2A470J	CHIP R		1/10W
R305			RK73FB2A311J	CHIP R		1/10W
R306			RK73FB2A311J	CHIP R		1/10W
R307			RK73FB2A392J	CHIP R		1/10W
R308			RK73FB2A332J	CHIP R		1/10W
R309			RK73FB2A222J	CHIP R		1/10W
R310			RK73FB2A473J	CHIP R		1/10W
R311			RK73FB2A562J	CHIP R		1/10W
R311			RS14KB3A820J	FL-PROOF RS		1W
R312			RK73FB2A302J	CHIP R		1/10W
R313			RK73FB2A393J	CHIP R		1/10W
R314			RK73FB2A472J	CHIP R		1/10W
R315			RK73FB2A391J	CHIP R		1/10W
R315			RK73FB2A473J	CHIP R		1/10W
R316			RK73FB2A104J	CHIP R		1/10W
R317			RK73FB2A392J	CHIP R		1/10W
R318			RK73FB2A333J	CHIP R		1/10W
R319			RK73FB2A222J	CHIP R		1/10W
R319			RK73FB2A332J	CHIP R		1/10W
R320			RK73FB2A222J	CHIP R		1/10W

L : Scandinavia
Y : PFI(Far East, Hawaii)
Y : AAFES(Europe)
K : USA
T : Europe
X : Australia
P : Canada
E : Europe
M : Other Areas
C : China
7 : KR-V7080
8 : KR-V8080
△ indicates safety critical components.

11

* New Parts
Parts without **Parts No.** are not supplied.
Les articles non mentionnés dans le **Parts No.** ne sont pas fournis.
Teile ohne **Parts No.** werden nicht geliefert.

Ref. No	Add-ress	New Parts	Parts No.	Description	Desti-nation	Re-marks
C551			CE04KW1C100M	ELECTRO		
C552			CK73FB1H103K	CHIP C		16WV
C553,554			CE04KW1C100M	ELECTRO		K
C555			CQ93FMG1H222J	MYLAR		16wv
C556			CQ93FMG1H103J	MYLAR		J
C557,558			CF92FV1H101K	MF-C		J
C561-572			CK73FSL1H101J	CHIP C		K
C601			CE04KW1C470M	ELECTRO		16WV
C602			CE04KW1C101M	ELECTRO		16WV
C604			CK73FB1H103K	CHIP C		K
C605			CK73FB1E104K	CHIP C		K
C606			CE04KW1H010M	ELECTRO		10WV
C703,704			CC73FSL1H470J	CHIP C		50WV
C705-707			CE04KW1C100M	ELECTRO		J
C708			CK73FB1H103K	CHIP C		16WV
C709			CE04KW1A221M	ELECTRO		K
C710			CK73FB1H103K	CHIP C		10WV
C711,712			CK73FSL1H221J	CHIP C		K
C713			CK73FB1H103K	CHIP C		K
CN501			E40-4609-05	PIN ASS'Y (15P)		YMC TE
CN502			E40-4294-05	FLAT CABLE CONNECTOR (4P)		
CN503			E40-4914-05	FLAT CABLE CONNECTOR (27P)		
J1			E11-0272-05	PHONE JACK (PHONES)		
J301			E70-0052-05	LOCK TERMINAL BOARD		
J701			E63-0138-15	PHONO JACK(4P VIDEO)		
J702			E11-0188-05	MINIATURE PHONE JACK(2P S.CON)		
E102			J11-0809-05	WIRE CLAMPER		
E103-106			J11-0808-05	WIRE CLAMPER		
CF301,302			L72-0531-05	CERAMIC FILTER		KPYXMC
CF301,302			L72-0536-05	CERAMIC FILTER		TE
CF303			L72-0574-05	CERAMIC FILTER		KPYXMC
L1,2			L40-1001-17	SMALL FIXED INDUCTOR(10UH,K)		TE
L3			L40-1091-17	SMALL FIXED INDUCTOR(10UH)		TE
L4			L40-1091-17	SMALL FIXED INDUCTOR(1UH)		YMC
L301,302			L79-1219-05	LC FILTER		TE
L303			L30-0910-05	FM IFT		TE
L305			L79-0125-05	LC FILTER		TE
L306			L39-1328-05	COMBINATION COIL		TE
L306			L39-1337-05	COMBINATION COIL		TE
L307			L30-0467-05	AM IFT		TE
L308,309			L40-1091-17	SMALL FIXED INDUCTOR(1UH)		TE
L310			L40-1091-17	SMALL FIXED INDUCTOR(1UH)		KPYXMC
L311			L40-1001-17	SMALL FIXED INDUCTOR(10UH,K)		TE
L311			L40-1021-14	SMALL FIXED INDUCTOR(1.0MH,K)		KPYXMC
L312			L40-1091-17	SMALL FIXED INDUCTOR(1UH)		KPYXMC
L403			L39-1328-05	COMBINATION COIL		KPYXMC
L403			L39-1337-05	COMBINATION COIL		KPYXMC
L406			L40-1091-17	SMALL FIXED INDUCTOR(1UH)		KPYXMC
L601			L40-1001-17	SMALL FIXED INDUCTOR(10UH,K)		TE
L602			L40-1091-17	SMALL FIXED INDUCTOR(1UH)		TE
X1			L78-0267-05	RESONATOR (4.194MHZ)		TE
X2			L78-0244-05	RESONATOR (4.000MH)		TE
X3			L77-2002-05	CRYSTAL RESONATOR(4.332MHZ)		TE

L : Scandinavia
Y : PFI(Far East, Hawaii)
Y : AAFES(Europe)
K : USA
T : Europe
X : Australia
P : Canada
E : Europe
M : Other Areas
C : China
7 : KR-V7080
8 : KR-V8080
△ indicates safety critical components.

KR-V7080/V8080

74

* New Parts
Parts without **Parts No.** are not supplied.
Les articles non mentionnés dans le **Parts No.** ne sont pas fournis.
Teile ohne **Parts No.** werden nicht geliefert.

Ref. No	Add-ress	New Parts	Parts No.	Description	Desti-nation	Re-marks
R381			RK73FB2A563J	CHIP R	1/10W	TE
R384			RK73FB2A101J	CHIP R	1/10W	TE
R401,402			RK73FB2A393J	CHIP R	1/10W	KPYXMC
R405,406			RK73FB2A123J	CHIP R	1/10W	KPYXMC
R411			RD14NB2E470J	RD	1/4W	KPYXMC
R418			RK73FB2A122J	CHIP R	1/10W	KPYXMC
R419			RK73FB2A123J	CHIP R	1/10W	KPYXMC
R422			RK73FB2A123J	CHIP R	1/10W	KPYXMC
R423			RK73FB2A123J	CHIP R	1/10W	KPYXMC
R424			RK73FB2A103J	CHIP R	1/10W	KPYXMC
R425,426			RK73FB2A393J	CHIP R	1/10W	KPYXMC
R427,428			RD14NB2E101J	RD	1/4W	KPYXMC
R431,432			RK73FB2A393J	CHIP R	1/10W	KPYXMC
R438,439			RK73FB2A561J	CHIP R	1/10W	KPYXMC
R440,441			RK73FB2A473J	CHIP R	1/10W	YMC
R451			RK73FB2A821J	CHIP R	1/10W	KPYXMC
R452			RK73FB2A473J	CHIP R	1/10W	KPYXMC
R453			RK73FB2A472J	CHIP R	1/10W	KPYXMC
R457			RK73FB2A102J	CHIP R	1/10W	KPYXMC
R467			RK73FB2A104J	CHIP R	1/10W	KPYXMC
R501,502			RK73FB2A103J	CHIP R	1/10W	KPYXMC
R503,504			RK73FB2A102J	CHIP R	1/10W	KPYXMC
R509			RK73FB2A473J	CHIP R	1/10W	47K
R510			RK73FB2A102J	CHIP R	1/10W	1.0K
R511			RK73FB2A222J	CHIP R	1/10W	2.2K
R512			RK73FB2A473J	CHIP R	1/10W	47K
R513			RK73FB2A100J	CHIP R	1/10W	10
R514			RK73FB2A233J	CHIP R	1/10W	22K
R516			RK73FB2A393J	CHIP R	1/10W	39K
R519			RK73FB2A105J	CHIP R	1/10W	1.0M
R521			RK73FB2A473J	CHIP R	1/10W	47K
R522			RK73FB2A102J	CHIP R	1/10W	1.0K
R523			RK73FB2A222J	CHIP R	1/10W	2.2K
R524			RK73FB2A473J	CHIP R	1/10W	47K
R525			RK73FB2A100J	CHIP R	1/10W	10
R526,527			RK73FB2A104J	CHIP R	1/10W	100K
R528			RK73FB2A223J	CHIP R	1/10W	22K
R531,532			RK73FB2A104J	CHIP R	1/10W	100K
R557			RK73FB2A233J	CHIP R	1/10W	22K
R601			RK73FB2A102J	CHIP R	1/10W	1.0K
R602			RK73FB2A222J	CHIP R	1/10W	2.2K
R603			RK73FB2A393J	CHIP R	1/10W	3.3K
R604			RK73FB2A103J	CHIP R	1/10W	10K
R606			RK73FB2A102J	CHIP R	1/10W	1.0K
R607			RS14KB3D270J	FL-PROOF RS	J 2W	27
R701-704			RK73FB2A750J	CHIP R	1/10W	75
R705,706			RK73FB2A332J	CHIP R	1/10W	3.3K
R707,708			RS14KB3A391J	FL-PROOF RS	J 1W	390
W201			R92-0670-05	CHIP R		0 OHM
W300			R92-0679-05	CHIP R		0 OHM
W401			R92-0670-05	CHIP R		0 OHM
W406			R92-0670-05	CHIP R		0 OHM
W408-411			R92-0670-05	CHIP R		0 OHM
W414-416			R92-0670-05	CHIP R		0 OHM
W418,419			R92-0670-05	CHIP R		0 OHM

L : Scandinavia
Y : PX(Far. East, Hawaii)
Y : AAFES(Europe)

K : USA
T : Europe
X : Australia

P : Canada
E : Europe
M : Other Areas

C : China

7 : KR-V7080
8 : KR-V8080

Δ indicates safety critical components.

73

* New Parts
Parts without **Parts No.** are not supplied.
Les articles non mentionnés dans le **Parts No.** ne sont pas fournis.
Teile ohne **Parts No.** werden nicht geliefert.

Ref. No	Add-ress	New Parts	Parts No.	Description	Desti-nation	Re-marks
R321,322			RK73FB2A122J	CHIP R	1/10W	TE
R321,322			RK73FB2A393J	CHIP R	1/10W	KPYXMC
R323			RK73FB2A472J	CHIP R	1/10W	TE
R324			RK73FB2A102J	CHIP R	1/10W	KPYXMC
R324			RK73FB2A472J	CHIP R	1/10W	TE
R325			RK73FB2A103J	CHIP R	1/10W	KPYXMC
R325			RK73FB2A561J	CHIP R	1/10W	TE
R325			RK73FB2A472J	CHIP R	1/10W	TE
R327			RK73FB2A473J	CHIP R	1/10W	TE
R328			RK73FB2A821J	CHIP R	1/10W	TE
R329,330			RK73FB2A102J	CHIP R	1/10W	TE
R331			RK73FB2A822J	CHIP R	1/10W	TE
R331			RS14KB3D221J	FL-PROOF RS	J 2W	220
R332,333			RK73FB2A102J	CHIP R	1/10W	KPYXMC
R332,333			RK73FB2A472J	CHIP R	1/10W	TE
R334			RK73FB2A104J	CHIP R	1/10W	100K
R335			RK73FB2A102J	CHIP R	1/10W	1.0K
R335			RK73FB2A472J	CHIP R	1/10W	4.7K
R336,337			RK73FB2A102J	CHIP R	1/10W	1.0K
R338			RK73FB2A102J	CHIP R	1/10W	TE
R338			RK73FB2A221J	CHIP R	1/10W	KPYXMC
R339			RK73FB2A822J	CHIP R	1/10W	8.2K
R340			RK73FB2A102J	CHIP R	1/10W	1.0K
R341			RK73FB2A471J	CHIP R	1/10W	470
R341			RK73FB2A821J	CHIP R	1/10W	820
R342			RD14NB2E101J	RD	1/4W	100
R343			RK73FB2A103J	CHIP R	1/10W	10K
R344			RK73FB2B221J	CHIP R	1/8W	220
R345			RK73FB2A122J	CHIP R	1/10W	1.2K
R346			RK73FB2A750J	CHIP R	1/10W	75
R347			RK73FB2A681J	CHIP R	1/10W	680
R349			RK73FB2A104J	CHIP R	1/10W	620
R350			RK73FB2A104J	CHIP R	1/10W	100K
R351			RK73FB2A181J	CHIP R	1/10W	470
R352			RK73FB2A104J	CHIP R	1/10W	180
R352			RK73FB2A472J	CHIP R	1/10W	100K
R353			RK73FB2A103J	CHIP R	1/10W	4.7K
R354,355			RK73FB2A223J	CHIP R	1/10W	20K
R356			RK73FB2A104J	CHIP R	1/10W	100K
R357			RK73FB2A473J	CHIP R	1/10W	47K
R358			RK73FB2A104J	CHIP R	1/10W	100K
R361			RK73FB2A122J	CHIP R	1/10W	1.2K
R362			RK73FB2A123J	CHIP R	1/10W	1.2K
R363			RK73FB2A122J	CHIP R	1/10W	1.2K
R364			RK73FB2A104J	CHIP R	1/10W	100K
R364			RK73FB2A123J	CHIP R	1/10W	12K
R365			RK73FB2A683J	CHIP R	1/10W	68K
R366			RK73FB2A473J	CHIP R	1/10W	47K
R367			RK73FB2A104J	CHIP R	1/10W	100K
R369			RK73FB2A102J	CHIP R	1/10W	1.0K
R370			RK73FB2A104J	CHIP R	1/10W	100K
R371			RK73FB2A102J	CHIP R	1/10W	1.0K
R378			RD14NB2E470J	RD	1/4W	47
R379			RS14KB3D221J	FL-PROOF RS	J 2W	220

L : Scandinavia
Y : PX(Far. East, Hawaii)
Y : AAFES(Europe)

K : USA
T : Europe
X : Australia

P : Canada
E : Europe
M : Other Areas

C : China

7 : KR-V7080
8 : KR-V8080

Δ indicates safety critical components.

KR-V7080/V8080

PARTS LIST

15 * New Parts
Parts without **Parts No.** are not supplied.
Les articles non mentionnés dans le **Parts No.** ne sont pas fournis.
Teile ohne **Parts No.** werden nicht geliefert.

Ref. No	Add-ress	New Parts	Parts No.	Description	Desti-nation	Re-marks
D308			1S5268	DIODE	TE	
D309			MA111	DIODE	TE	
D310			MA111	DIODE	KPYXMC	
D311			HZS6.2N(B2)	ZENER DIODE	KPYXMC	
D311			RD8.2ES(B2)	ZENER DIODE	KPYXMC	
D411.412			MA111	DIODE	KPYXMC	
D601.602			MA111	DIODE	KPYXMC	
D603			HZS10N(B)	ZENER DIODE		
D603			RD10ES(B)	ZENER DIODE		
D703.704			HZS5.1N(B2)	ZENER DIODE		
D703.704			RD5.1ES(B2)	ZENER DIODE		
D705.706			HSS104	DIODE		
D705.706			1SS133	DIODE		
ED1			11-MT-92GK	INDICATOR TUBE		
IC1		*	UPD78044AGF160	MI-COM IC	KPYXMC	
IC1		*	UPD78045AGF027	MI-COM IC	TE	
IC2			S-806D-Z	ANALOGUE IC	TE	
IC3			SAA6579	ANALOGUE IC	TE	
IC4			LC8643H-4D68	MI-COM IC	TE	
IC301			LA1831A-KEN	ANALOGUE IC	KPYXMC	
IC301			LA1836	ANALOGUE IC	TE	
IC302			LC7218	IC(PLL FREQUENCY SYNTHESIZER)	TE	
IC303			M5223P	IC(OP AMP X2)	TE	
IC312			NJM4565D	IC(OP AMP X2)	KPYXMC	
IC501		*	LA2786	ANALOGUE IC	TE	
IC502			LV1015	DI BI-POLAR IC	YMC	
IC503		*	NUM4565L-D	ANALOGUE IC	YMC	
IC701			NJM2279D	IC(VIDEO IC)	KPYXMC	
Q1			2SC4081(R,S)	TRANSISTOR	KPYXMC	
Q1			2SC4116(Y,GR)	TRANSISTOR	TE	
Q2			2SC2458(Y,GR)	TRANSISTOR	TE	
Q2			2SC3311A(Q,R)	TRANSISTOR	TE	
Q3			2SA1048(Y,GR)	TRANSISTOR	TE	
Q3			2SA1309A(Q,R)	TRANSISTOR	TE	
Q301			2SC2714(R,O)	TRANSISTOR	KPYXMC	
Q302			2SC1845(F,E)	TRANSISTOR	KPYXMC	
Q303			2SC2458(Y,GR)	TRANSISTOR	KPYXMC	
Q303			2SC3311A(Q,R)	TRANSISTOR	TE	
Q303			2SC4081(R,S)	TRANSISTOR	TE	
Q303			2SC4116(Y,GR)	TRANSISTOR	TE	
Q304.305			2SC4081(R,S)	TRANSISTOR	TE	
Q304.305			2SC4116(Y,GR)	TRANSISTOR	TE	
Q307		*	2SA1576A(R,S)	TRANSISTOR	TE	
Q307			2SA1586(Y,GR)	TRANSISTOR	TE	
Q307			2SC4081(R,S)	TRANSISTOR	KPYXMC	
Q307			2SC4116(Y,GR)	TRANSISTOR	KPYXMC	
Q308		*	2SA1576A(R,S)	TRANSISTOR	TE	
Q308			2SA1586(Y,GR)	TRANSISTOR	TE	
Q309			2SC3940A(R,S)	TRANSISTOR	TE	
Q309			2SD8663(E,F)	TRANSISTOR	TE	
Q310		*	2SA1576A(R,S)	TRANSISTOR	TE	
Q310			2SA1586(Y,GR)	TRANSISTOR	TE	
Q311			2SC3940A(R,S)	TRANSISTOR	KPYXMC	
Q311			2SD1757K	TRANSISTOR	TE	
Q311			2SD8663(E,F)	TRANSISTOR	KPYXMC	

15 * New Parts
Parts without **Parts No.** are not supplied.
Les articles non mentionnés dans le **Parts No.** ne sont pas fournis.
Teile ohne **Parts No.** werden nicht geliefert.

Ref. No	Add-ress	New Parts	Parts No.	Description	Desti-nation	Re-marks
W420.421			R92-0670-05	CHIP R	TE	
W422			R92-0670-05	CHIP R	KPYXMC	
W426			R92-0670-05	CHIP R	KPYXMC	
W446			R92-0670-05	CHIP R	KPYXMC	
W448			R92-0670-05	CHIP R	KPYXMC	
W501.502			R92-0679-05	CHIP R	YMC	
W504			R92-0679-05	CHIP R	KPYXMC	
W505-508			R92-0679-05	CHIP R	KPYXMC	
W510-512			R92-0679-05	CHIP R	KPYXMC	
S1			S70-0031-05	TACT SWITCH (REMOTE POWER)	TE	
S2-4			S70-0031-05	TACT SWITCH (RDS)		
S5-36			S70-0031-05	TACT SWITCH		
S39			S40-1138-05	PUSH SWITCH (MAIN POWER)		
S401			S62-0034-05	SLIDE SWITCH (DE-EMPHASIS)	YMC	
S37			T99-0559-05	ROTARY ENCODER(VOLUME CONTROL)		
S38			T99-0571-05	ROTARY ENCODER(INPUT SELECTOR)		
D1			HZS6.2N(B2)	ZENER DIODE		
D1			RD6.2ES(B2)	ZENER DIODE		
D2.3			HSS104	DIODE		
D2.3			1SS133	DIODE		
D4			MA111	DIODE		
D6.7			HSS104	DIODE		
D6.7			1SS133	DIODE		
D8			MA111	DIODE		
D9-14			HSS104	DIODE		
D9-14			1SS133	DIODE		
D16			HSS104A	DIODE	YMC	
D16			1SS131	DIODE	YMC	
D21-28			HSS104A	DIODE	YMC	
D21-28			1SS131	DIODE	YMC	
D29			HSS104A	DIODE	YMC	
D29			1SS131	DIODE	YMC	
D31			HSS104A	DIODE	YMC	
D31			1SS131	DIODE	YMC	
D32-35			HSS104	DIODE	YMC	
D32-35			1SS133	DIODE	YMC	
D301.302			HSS104	DIODE	YMC	
D301.302			1SS133	DIODE	YMC	
D303			HZS5.1N(B2)	ZENER DIODE		
D303			RD5.1ES(B2)	ZENER DIODE		
D304			HZS3.3N(B2)	ZENER DIODE		
D304			HZS6.2N(B2)	ZENER DIODE	KPYXMC	
D304			RD3.3ES(B2)	ZENER DIODE	TE	
D304			RD8.2ES(B2)	ZENER DIODE	TE	
D305			HSS104	ZENER DIODE	TE	
D305			1SS133	DIODE	TE	
D306			HZS3.3N(B2)	ZENER DIODE	TE	
D306			RD3.3ES(B2)	ZENER DIODE	TE	
D307			HSS104	DIODE	KPYXMC	
D307			MA111	DIODE	TE	
D307			1SS133	DIODE	TE	
D308			HSS104	DIODE	KPYXMC	
D308			1SS133	DIODE	KPYXMC	

L : Scandinavia
Y : FX(Far East, Hawaii)
Y : AA(FES)(Europe)
K : USA
P : Canada
E : Europe
X : Australia
M : Other Areas
C : China
7 : KR-V7080
8 : KR-V8080
Δ indicates safety critical components.

L : Scandinavia
Y : FX(Far East, Hawaii)
Y : AA(FES)(Europe)
K : USA
P : Canada
E : Europe
X : Australia
M : Other Areas
C : China
7 : KR-V7080
8 : KR-V8080
Δ indicates safety critical components.

KR-V7080/V8080

PARTS LIST

17
 * New Parts
 Parts without **Parts No.** are not supplied.
 Les articles non mentionnés dans le **Parts No.** ne sont pas fournis.
 Teile ohne **Parts No.** werden nicht geliefert.

Ref. No	Add- ress	New Parts	Parts No.	Description	Desti- nation	Re- marks
Q312			2SD1757K	TRANSISTOR	TE	
Q316			2SC4081(R,S)	TRANSISTOR	TE	
Q316			2SC4116(Y,GR)	TRANSISTOR	TE	
Q317		*	2SA1576A(R,S)	TRANSISTOR	TE	
Q317		*	2SA1586(Y,GR)	TRANSISTOR	TE	
Q318			2SC4081(R,S)	TRANSISTOR	TE	
Q318			2SC4116(Y,GR)	TRANSISTOR	TE	
Q402		*	2SA1576A(R,S)	TRANSISTOR	KPYXMC	
Q402			2SA1586(Y,GR)	TRANSISTOR	KPYXMC	
Q404		*	2SA1576A(R,S)	TRANSISTOR	KPYXMC	
Q404			2SA1586(Y,GR)	TRANSISTOR	KPYXMC	
Q407_408			2SC4081(R,S)	TRANSISTOR	YMC	
Q407_408			2SC4116(Y,GR)	TRANSISTOR	YMC	
Q409_410			2SD1757K	TRANSISTOR	KPYXMC	
Q411		*	2SA1576A(R,S)	TRANSISTOR	KPYXMC	
Q411			2SA1586(Y,GR)	TRANSISTOR	KPYXMC	
C601-603			DTC124EU	DIGITAL TRANSISTOR		
C601-603			UN5212	TRANSISTOR		
C604			2SC3940A(R,S)	TRANSISTOR		
C604			2SD863(E,F)	TRANSISTOR		
A1			W02-1174-05	ELECTRIC CIRCUIT MODULE	TE	
A301			W02-2509-05	FM FRONT-END ASSY	KPYXMC	
A301			W02-2512-05	FM FRONT-END ASSY	KPYXMC	

L : Scandinavia
 Y : PX(Far East, Hawaii)
 V : AAFES(Europe)

K : USA
 P : Canada
 T : Europe
 X : Australia

C : China
 7 : KR-V7080
 8 : KR-V8080

▲ indicates safety critical components.

KR-V7080/V8080

SPECIFICATIONS

Audio section

Rated power output at the STEREO operation

100 watts per channel minimum RMS, both channels driven at 8 Ω, from 20 Hz to 20,000 Hz with no more than 0.06 % total harmonic distortion. (FTC)

Power output at the SURROUND operation

Front

100 watts per channel minimum RMS, both channels driven, at 8 Ω, 1 kHz with no more than 0.7 % total harmonic distortion. (FTC)

Center

100 watts minimum RMS at 8 Ω, 1 kHz with no more than 0.7 % total harmonic distortion. (FTC)

Rear

30 watts per channel minimum RMS, both channels driven, at 8 Ω, 1 kHz with no more than 0.7 % total harmonic distortion. (FTC)

Total harmonic distortion

.....0.01 % (1 kHz, 50 W, 8 Ω)

Signal to noise ratio (IHF'66)

PHONO (MM)75 dB

LINE (CD)95 dB

Input sensitivity / impedance

PHONO (MM)2.5 mV / 47 kΩ

CD, TAPE, VIDEO200 mV / 47 kΩ

Tone controls

BASS± 8 dB (at 100 Hz)

TREBLE± 8 dB (at 10 kHz)

LOUDNESS control at - 30 dB VOLUME level

.....+ 6 dB (100 Hz)

Output level / impedance

Sub woofer preout1.0 V / 2.2 kΩ

Video section

VIDEO inputs / outputs (Composite)1 Vp-p / 75 Ω

FM Tuner section

Tuning frequency range87.5 MHz ~ 108 MHz

Usable sensitivity

MONO1.2 μV (75 Ω) / 13.2 dBf
(75 kHz dev., S/N 30 dB)

50 dB quieting sensitivity

STEREO32 μV (75 Ω) / 41.2 dBf
(75 kHz dev.)

Total harmonic distortion (1 kHz)

MONO0.6 % (65.2 dBf input)

STEREO0.7 % (65.2 dBf input)

Signal to noise ratio (1 kHz 75 kHz dev.)

MONO75 dB (65.2 dBf input)

STEREO68 dB (65.2 dBf input)

Stereo separation

1 kHz40 dB

Selectivity (IHF ±400 kHz)50 dB

Frequency response30 Hz ~ 15 kHz, + 0.5 dB, - 3.0 dB

AM Tuner section

Tuning frequency range530 kHz ~ 1,700 kHz

Usable sensitivity (30 % mod., S/N 20 dB)

.....12 μV / (500 μV / m)

Signal to noise ratio (30 % mod., 1 mV input)48 dB

Total harmonic distortion0.7 %

Selectivity30 dB

General

Power consumption4 A

AC outlet

SWITCHED2: (total 65 W, 0.54 A max.)

DimensionsW : 440 mm (17-5 / 16")

H : 148 mm (5-13 / 16")

D : 389 mm (15-5 / 16")

Weight (net)10.2 kg (22.5 lb)