

KENWOOD
HI/FI STEREO COMPONENTS

SERVICE MANUAL

KT-7500
(KT-7550)

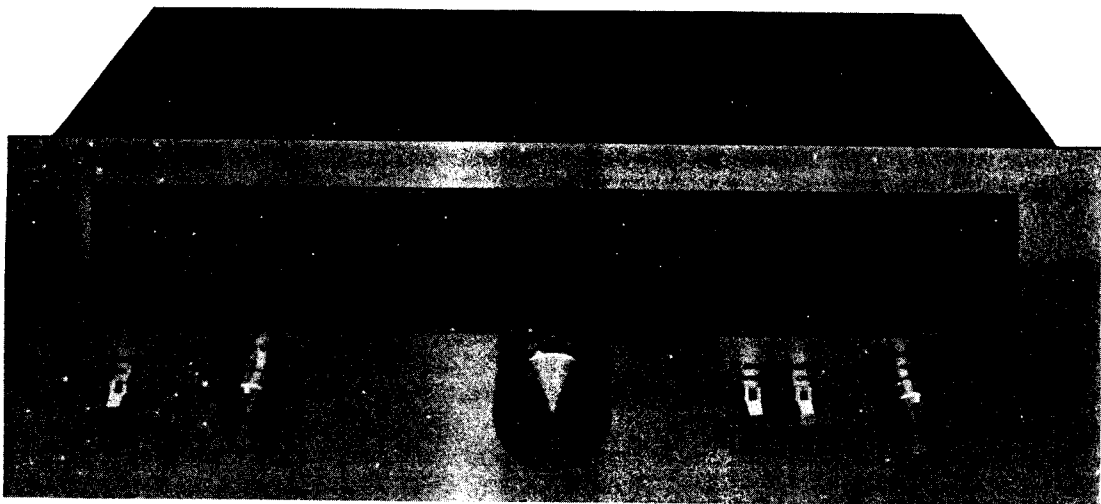

AM-FM STEREO TUNER

KT-7500

TOP VIEW/DIAL CORD STRINGING

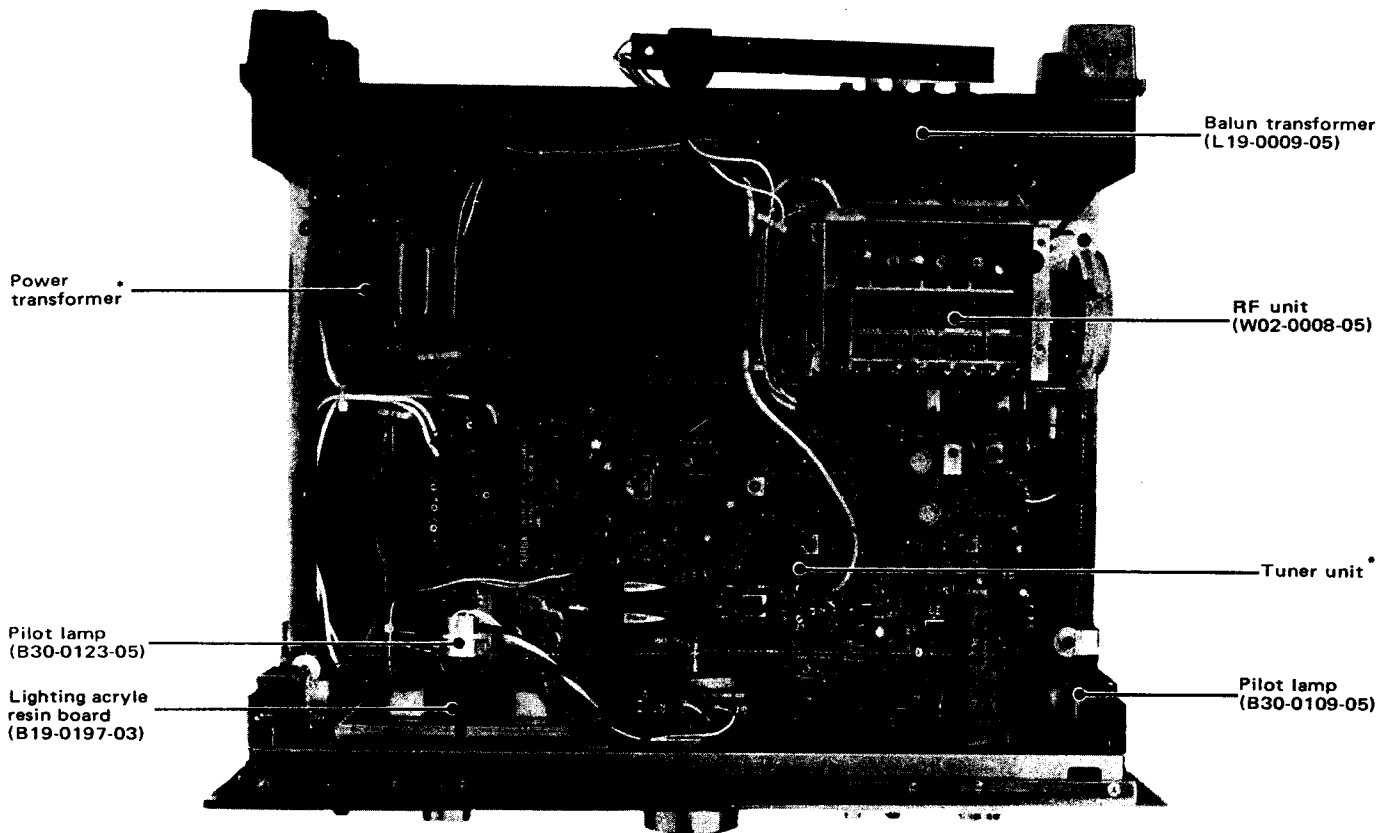

DIAL CORD STRINGING

1. Fully close the variable capacitor.
2. Assemble the dial pulley A with the pulley B and fix them on the shaft of the variable capacitor using 2 screws.
3. Tie the end of the dial cord to the boss C as shown.
4. Dress the dial cord in the direction of "1" through "5" and wind it 3 turns around the dial shaft starting from its lower side.
5. Dress the dial cord in the direction of "6" to "7" and wind it 2 turns around the pulley B starting from its lower side. Then, fix it to the boss D at the rear side.
6. Mount the dial pointer as shown in the illustration.

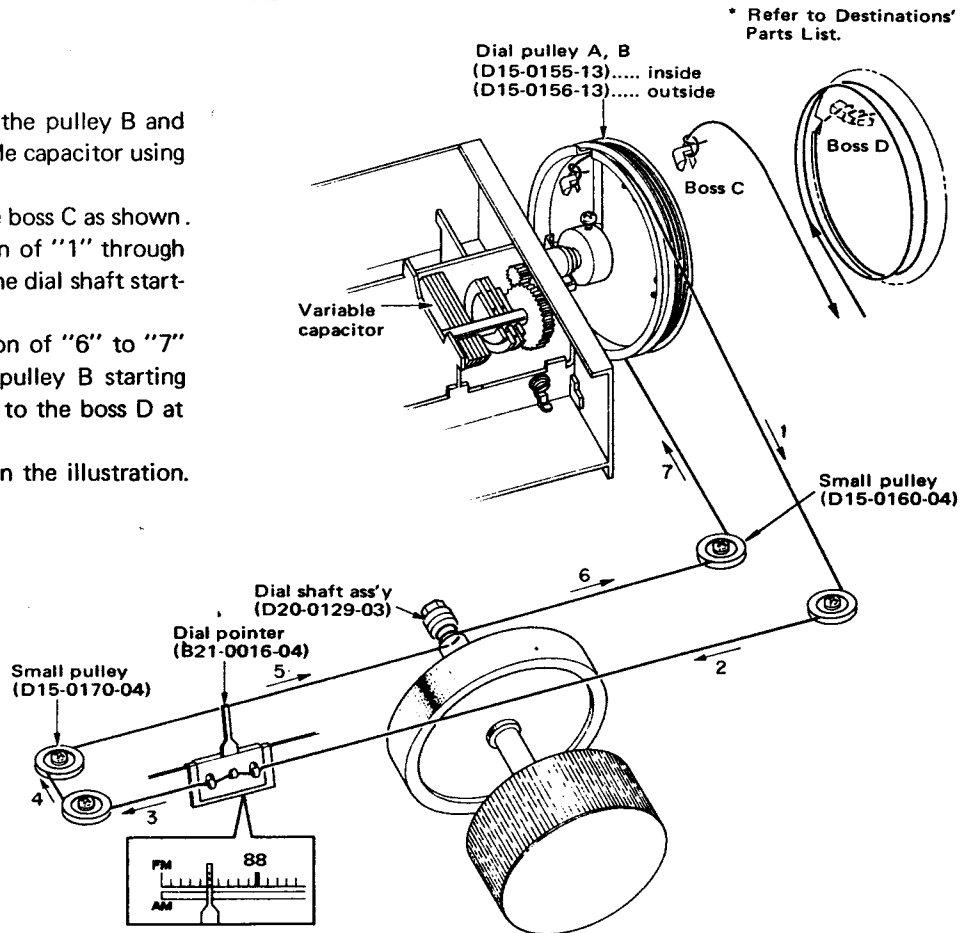

DISASSEMBLY

METER

- ① Remove the case.
- ② Remove the two Br-Tap screws fixing the lighting acryle resin board to the sub panel.
- ③ Then, S meter or T meter can be replaced.

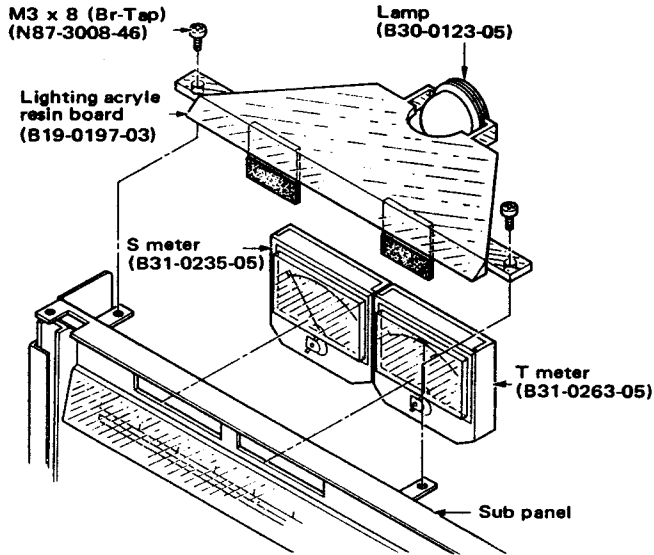

LED

- ① Remove the case.
- ② Remove the two Br-Tap screws fixing the (X02-1080-) B/5 to the sub panel.
- ③ Then, LEDs can be replaced.

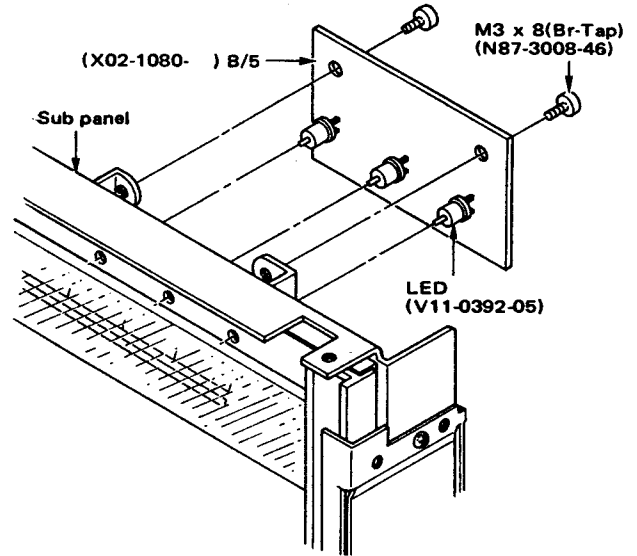

PANEL

- ① Remove the case.
- ② Pull out the knobs. (For tuning knob, use a hexagon wrench.)
- ③ Remove the five screws, the two on the bottom and the three on the top, fixing the panel to the sub panel.
- ④ Then, the panel can be replaced.

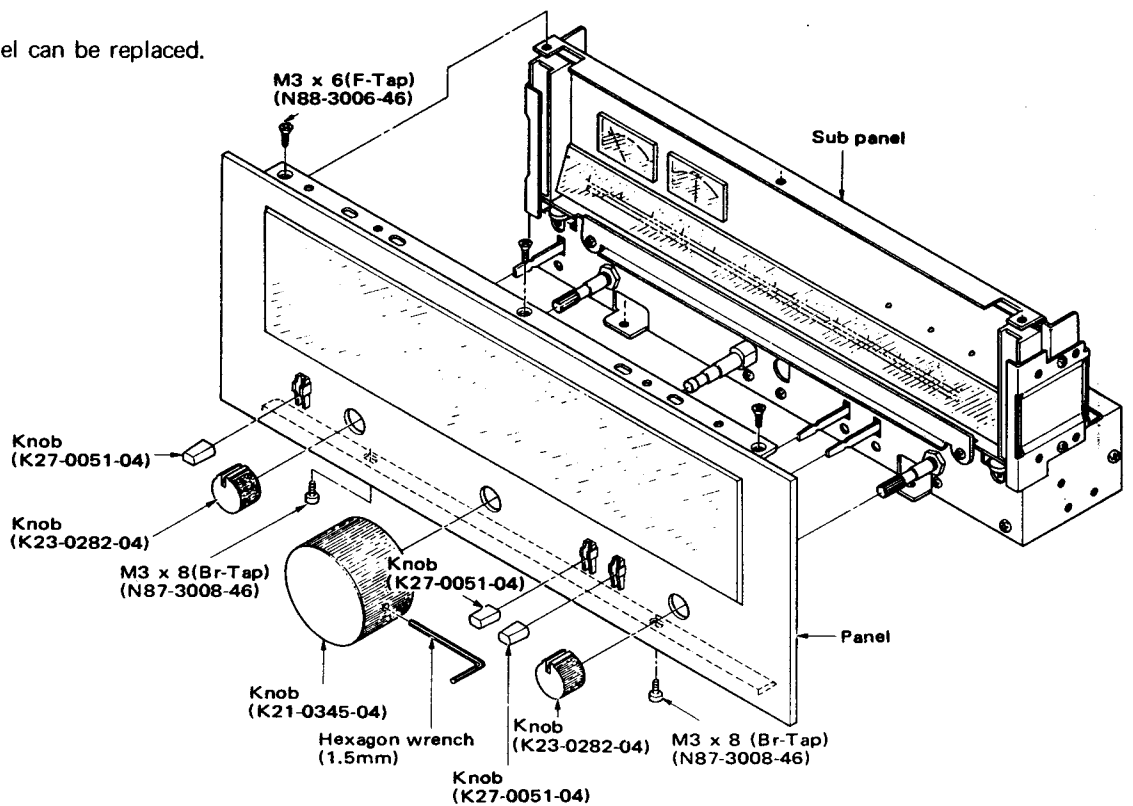

BLOCK DIAGRAM/CIRCUIT DESCRIPTION

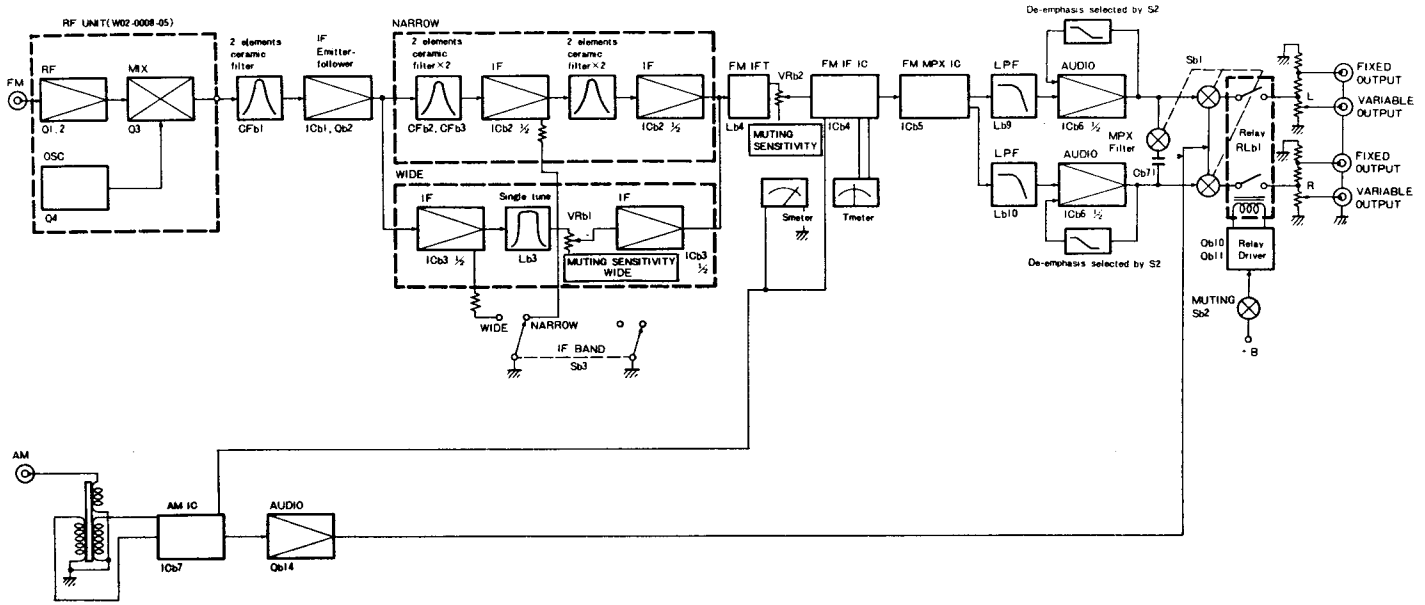

RF UNIT (W02-0008-05)

The RF unit is composed of an ANT circuit, a linear type 5-gang variable capacitor for FM, a 2-gang variable capacitor for AM, a single-double-single tune circuit, an OSC circuit and a mixer. A new MOS FET 3SK59 is used for the second RF amp and the mixer. The ANT coil T1 and the OSC coil use non-variable ones so that they can not be adjusted.

If replacement of FETs and transistors does not solve a trouble, replace the RF unit (W02-0008-05).

FM IF CIRCUIT

The IF band is switchable in 2 steps, WIDE and NARROW. The WIDE stage uses a 2-elements ceramic filter and a single-tune IFT to assure 30 dB selectivity at a 400 kHz distance, which the NARROW stage uses the five 2-elements ceramic filters to assure 100 dB selectivity. Selection of WIDE and NARROW can be accomplished by varying the DC voltage supplied to ICb2 and ICb3.

VRb2 determines a total MUTING SENSITIVITY of the IF circuit. VRb1 determines a MUTING SENSITIVITY at the WIDE operation. Lb3 is used to adjust the T meter to its center position at the WIDE operation. The IF signal is discriminated by HA1137W.

OPERATION OF HA1137W

HA1137W consists of the IF amps, a quadrature detector, a muting circuit and a meter circuit. The IF signal partly applied to the quadrature detector through the three IF amps. Also the IF signal is applied to the quadrature detector after lagging by a "90° ± Δφ phase shifter" Lb8. The audio output is derived from the terminal 6 by multiplying these signals each other.

The signal for the S meter is derived from the terminal 13. The signal for the T meter is derived from the terminal 7.

FM MPX CIRCUIT

The FM MPX circuit uses PLL IC HA1196. The operation is almost the same as that of HA1156W. The HA-1196 is improved in the following points:

1. The terminal 12 for the FM muting operation is provided. However, this terminal is not used in the KT-7500.
2. A current booster is provided on the synchronizing detector to minimize distortion.
3. An amplifier is provided after the synchronizing detector.
4. The number of the terminals is 16, on the other hand, that of HA1156Ws' is 14.

OPERATION OF HA1196

The stereo composite signal is fed to the terminal 2. It is applied to the synchronizing detector, PD-1 and PD-2 through the audio amplifier. When the control voltage is absent, VCO is set in a free run oscillating state at about 76 kHz. The output of VCO is divided into 19 kHz by the dividers DIV-1 and DIV-2, and its phase is compared with the phase of the 19 kHz pilot signal by PD-1. In practical application, a multiplier is used as a phase detector to produce an output proportional to the product of 2 input signals (19 kHz pilot signal and 19 kHz VCO). This output, after its unwanted component is removed by LPF, consisting of Cb35, Cb36 and Rb44, is amplified by the DC amplifier and is fed to VCO as a control voltage. With this voltage, VCO oscillates a signal 4 times the frequency of the pilot signal.

CIRCUIT DESCRIPTION

The 38 kHz signals obtained by VCO is fed, as switching signals, to the synchronizing detector circuit through the stereo auto switch. Since the 38 kHz signals are the ideal square wave signals, they do not include even number harmonics and they will not produce a beat with SCA signal (67 ± 7 kHz), thus eliminating the need for SCA filter.

When a monaural signal or a weak stereo signal is received, the stereo auto switch makes the 38 kHz signals, which are balanced outputs, the same phase and stops the operation of the synchronizing detector. As a result, the demodulated audio signal turns monaural preventing the deterioration of SN ratio.

Functions of stereo auto switch:

The output of DIV-1 is partly fed to DIV-3 and is divided into 19 kHz. It is then fed to the one side of the input of PD-2.

The 19 kHz signal of DIV-3 is phase locked by the 19 kHz pilot signal during stereo reception, so that a DC voltage proportional to the amplitude of the pilot signal is developed in the PD output.

In monaural broadcast, there is no pilot signal and therefore no voltage is developed. Also, in stereo broadcast, if the signal is weak, it does not reach the trigger level so the following functions are not effected.

The DC signal is fed to the trigger circuit through LPF, consisting of Rb41 ~ Rb43 and Cb34, and when its level is above the predetermined threshold, the stereo switch turns on to send the 38 kHz switching signals in anti phase with each other to the synchronizing detector and the stereo lamp lights.

The signal is demodulated to L and R signals by the synchronizing detector. And the SEPARATION is adjusted by VRb5 for NARROW or VRb6 for WIDE respectively to get the best characteristics.

PLL LOOP RESPONSE CONTROL CIRCUIT

This set is provided with a PLL loop response control circuit which was primarily developed for the KT-8300 and the model 600T by KENWOOD's original design techniques. The stereo demodulator circuit making use of PLL may often suffer from beat distortion. There would be no problem if output of the phase detector PD-1 contains the DC component only. However, it actually contains various frequency spectrums (of AC components) which give rise to FM modulation of VCO and badly affect the 38kHz sub-carrier. The signals switched by the 38kHz sub-carrier in unstable phase arrangements often interfere with the audio component of (L + R) and the DSB component of (L - R), thus resulting in beating trouble and unclear sound reproduction. Such a phenomenon is called beat distortion. In order to remove such difficulties, the following method is adopted for the KT-8300 and the model 600T.

1. Method for KT-8300 and model 600T

The attenuation rate of the low-pass filter (equivalent to Cb35, Cb36, and Rb44 in the block diagram of HA-1196) is increased to cut off the AC component. However, this will simultaneously narrow the capture range of PLL and locking may be impossible at the pilot signal. Therefore the input level is raised before locking, and is returned to the original level after locking.

2. Method of KT-7500

In the above case the input level itself is not changed, and instead the level of audio amplifier output to be fed to the PD-1 is controlled by Qb7. In other words, if stereo broadcast is received, the lamp is lit and the terminal 9 of ICb5 is put at the ground potential. The

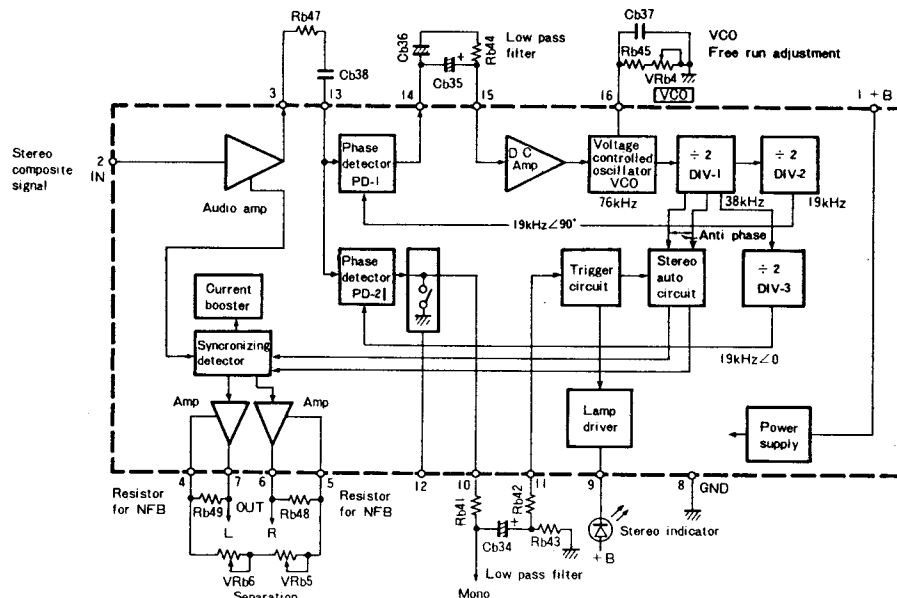

HA1196 BLOCK DIAGRAM

CIRCUIT DESCRIPTION

base potential of Qb7 is about 0.6V and Qb7 is thus turned on. As a result Rb52 is connected to the audio amplifier output as a load, thus lowering the input level of the PD-1. This effect is the same as when the filter effect of the low-pass filter is increased. In this way the circuit is improved against beat distortion. The lamp sensitivity is higher than usual because of adoption of Rb41 ~ 43.

MUTING CIRCUIT

Relay RLb1 of the muting circuit is operated when Qb10 and Qb11 are turned on, while it is released when they are turned off.

1. Prevention of shock noise when POWER switch is ON

The circuit is designed so that rectified voltage at Db12 can be raised slowly when the POWER switch is turned on. Therefore, it takes several seconds to make Qb10 and Qb11 turned on (Rb94, Cb74 and Rb92, Cb72).

2. Prevention of shock noise when POWER switch is OFF

Since anode potential of Db11 is higher than cathodes potential of Db11 after the POWER switch has been turned off, Db11 is turned on and discharge occurs quickly at a time constant which is dependent on Cb75 and Rb95. Therefore, Qb10 and Qb11 are turned off instantaneously.

3. Prevention of shock noise when IF band is switched over

In the middle of IF band switching over, both contacts of Sb3-b are isolated from ground potential. Thus Qb9 is turned on and Qb10 and Qb11 are turned off. In the NARROW or WIDE setting, Qb9 is turned off and Qb10 and Qb11 are turned on since base potential of Qb9 is lowered to ground potential by Db7 or Db8.

4. Prevention of noise during AM \rightleftharpoons FM switching over

Since Sb1 is a short-type switch, both contacts are simultaneously connected in the middle of switching over. At that time Qb12 and Qb13 are simultaneously biased by Sb1-b and are turned on.

Qb10 and Qb11 are turned off. In the AM or FM setting, Qb12 and Qb13 are not biased simultaneously and thus Qb10 and Qb11 are not turned off.

5. FM muting

When the muting switch Sb2 is turned on, the collector bias of Qb10 is not fixed. When the terminal 12 of ICb4 is at zero volt (while tuned at a sufficient input level), Qb6 is OFF, Qb5 is ON, Qb4

is ON, and Qb3 is OFF. As a result collector potential of Qb3 is high and +B is supplied to the collector of Qb10 to turn it on. When DC voltage appears at the terminal 12 of ICb4 (detuning), Qb6 is ON, Qb4 is OFF, and Qb3 is ON. As a result collector potential of Qb3 is lowered to zero volt and +B is removed from the collector Qb10, thus turning it off. Qb5 is used to make up an AND condition in conjunction with the condition of the S meter (the terminal 13 of ICb4) and that of tuning (the terminal 12 of ICb4). In the AM setting, +B of AM is supplied to the collector of Qb10 which is therefore turned on. Since the build-up time for +B is short in the FM setting (Rb81 and Cb87), there is no occurrence of shock noise at time of switching over from AM to FM.

DIODE FUNCTIONS

Db1: Stops the operation of HA1137W in AM setting and prevents a reverse flow of +B from FM circuit to AM circuit.

Db2: Stops the operation of VCO in AM setting by use of +B and prevents a reverse flow of +B from FM circuit to AM circuit.

Db3: Prevents a reverse flow from AM circuit to FM circuit.

Db4: Improves the build-up characteristic of +B to be supplied to Qb12 and Qb13 (to avoid influence of Cb87 and Rb81).

Db5: Prevents a reverse flow of +B.

Db6: Prevents a reverse flow of +B from FM circuit to AM circuit.

Db7, 8: Prevents a reverse flow from NARROW circuit to WIDE circuit.

Db9: Reduces a build-down time of +B.

Db10: Used for compensation of Db7 and Db8.

Db11: Reduces a build-down time of +B.

Db12: Used for +B rectification for Qb10.

Db13~16: Used for $\pm B$ rectification.

Db17: Stabilizes 14V of +B.

Db18: Stabilizes 14V of -B.

Db22: Used for forced monaural operation at time of detuning.

Db23: Prevents AM radiation.

Db24: Used for tuning for muting and improvement of response characteristic at time of detuning.

AM CIRCUIT

The AM circuit uses IC HA1197. The RF signal from the bar antenna is fed to the terminal 2 of ICb7 and derived from the terminal 12 of ICb7. The AM signal is amplified by Qb14 and fed to ICb6. The S meter output is taken out of the terminal 15 of ICb7.

PRIMARY CIRCUIT/TEST EQUIPMENTS AND SPECIFICATIONS

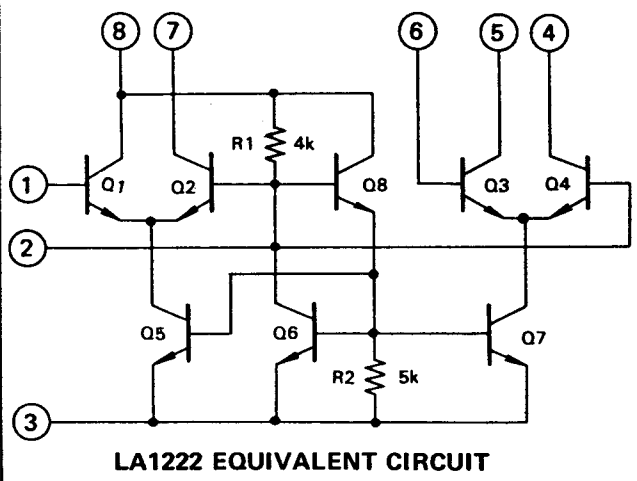
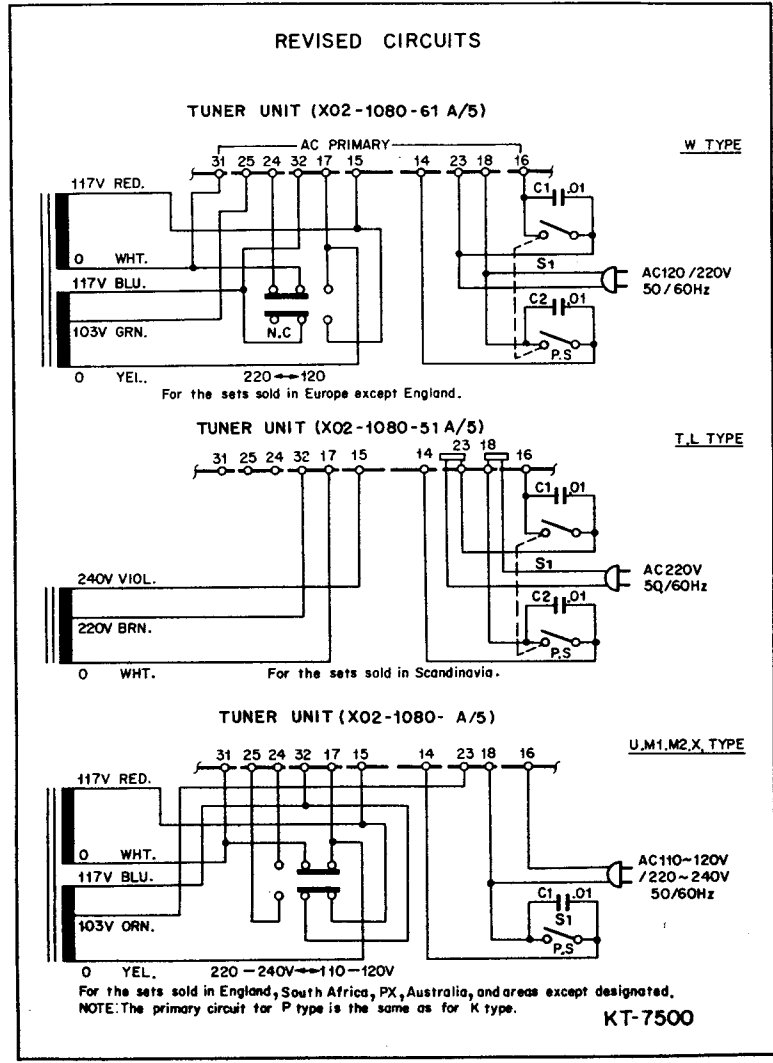

TEST EQUIPMENTS AND SPECIFICATIONS

STANDARD SIGNAL GENERATOR (RF-SG)

Ranges	90 MHz~108 MHz (FM) 500 kHz~1600 kHz (AM)
Modulation Frequency	1 kHz, 400 Hz or external input (Input level 2V or less)
Deviation (FM)	0~75 kHz (FM)
Modulation (AM)	0~30%
Output	100 mV or more
Distortion	0.5% or less

SOLID STATE VOLT METER (SSVM)

Ranges	0.3 mV~300V (full scale)
Frequency Response	5 Hz~500 kHz
Impedance	1 MΩ or more

OSCILLOSCOPE (SCOPE)

Ranges	DC~10 MHz
Sensitivity	20 mV/cm
Impedance	1 MΩ or more

MULTIPLEX SIGNAL GENERATOR (MPX-SG)

Modulation Frequency	1 kHz or external input (Input level: 5V or less)
Separation S/N	60 dB or more 85 dB or more

DISTORTION METER

Ranges	0.1%~0.03% (full scale)
Sensitivity	100 mV or more

FREQUENCY COUNTER (COUNTER)

Frequency Response	10 Hz~1 MHz
Sensitivity	50 mV or more
Impedance	1 MΩ or more

AUDIO SIGNAL GENERATOR (AG)

Ranges	5 Hz~500 kHz
Waveform	Sine wave
Output	10V r.m.s.
Distortion	0.01% or less

Notes:

- * 1. As for the specifications of Test Equipments, see page 12.
- * 2. RF-SG is set the lowest response possible on oscilloscope.
- * 3. TRACKING has been properly adjusted at the factory, so there is no necessity for readjusting. When repairing the RF unit (W02-0008-05), if replacement of FETs and transistors does not solve a trouble, replace the RF unit.
- * 4. The output level of RF-SG is made a loss by the dummy antenna. The loss is different from the dummy antenna, so you should take into consideration the value of the loss applicable to your case.
- * 5. 0 dB = 1 μ V

NO.	ALIGNMENT	TEST EQUIPMENT		TUNER SETTING	OUTPUT INDICATOR	ADJUSTMENT	REMARKS
		CONNECTION	SETTING				
FM SECTION VRb1 and VRb2 are in its mechanical center at the start.							
1	IF	Ⓐ	95 MHz 1 kHz (Mod) 75 kHz (Dev)	95 MHz NARROW	Ⓑ	Lb4 T5	Maximum deflection and minimum distortion.
2a		—	—	— NARROW	T meter	Lb8 (Bottom)	Make the pointer position in the center of the meter.
2b		—	—	— WIDE	T meter	Lb3	Make the pointer position in the center of the meter.
3		Ⓐ	95 MHz 1 kHz (Mod) 75 kHz (Dev)	95 MHz NARROW	Ⓑ	Lb8 (Top)	Maximum deflection and minimum distortion.
4	TRACKING * 3	Ⓐ	90 MHz 1 kHz (Mod) 75 kHz (Dev)	90 MHz NARROW or WIDE	Ⓑ	T2~T4	Maximum deflection
5			106 MHz (Dev) 1 kHz (Mod) 75 kHz (Dev)	106 MHz NARROW or WIDE		CT1~CT5	
6a	MUTING SENSITIVITY	Ⓐ	95 MHz 16 dB (5 μ V) * 4 1 kHz (Mod) 75 kHz (Dev)	95 MHz NARROW	Ⓑ	VRb2	Set the semi-fixed resistor so that MUTING will operate under the 16 dB(5 μ V) antenna input.
6b		Ⓐ	— ditto —	95 MHz WIDE	Ⓑ	VRb1	— ditto —
7	S METER	Ⓐ	95 MHz 10 dB * 4 0 (Dev)	95 MHz NARROW	S meter	VRb3	Make the pointer indication "5" digit.
8	VCO	Ⓐ	95 MHz 60 dB 0 (Dev)	95 MHz NARROW	Ⓒ	VRb4	Counter indicates 76 kHz
9a	SEPARATION	Ⓓ	FM-MPX: SELECTOR L or R 1 kHz (Mod) FM-SG: 95 MHz, 60 dB 68.25 kHz (Dev)	95 MHz NARROW	Ⓑ	VRb5	Minimum cross-talk (Maximum separation)
9b		Ⓓ	— ditto —	95 MHz WIDE	Ⓑ	VRb6	— ditto — Don't move the VRb5.
AM SECTION							
1	IF	Ⓔ	1000 kHz 400 Hz, 30% (Mod) *	1000 kHz	Ⓑ	CFb6	Maximum deflection
2	TRACKING	Ⓔ	600 kHz 400 Hz, 30% (Mod)	600 kHz	Ⓑ	Lb11 Ferrite bar antenna	— ditto —
3			1400 kHz 400 Hz, 30% (Mod)	1400 kHz	Ⓑ	CT6~7	

MENT

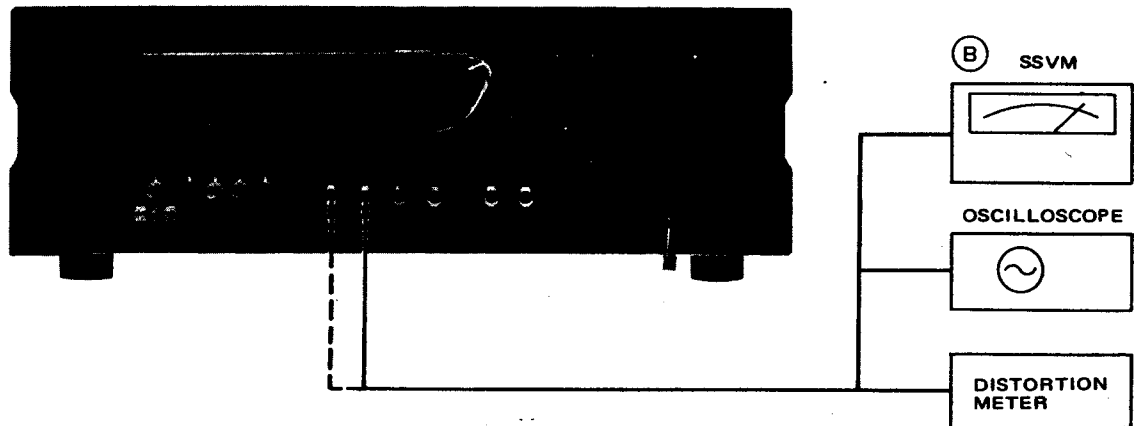
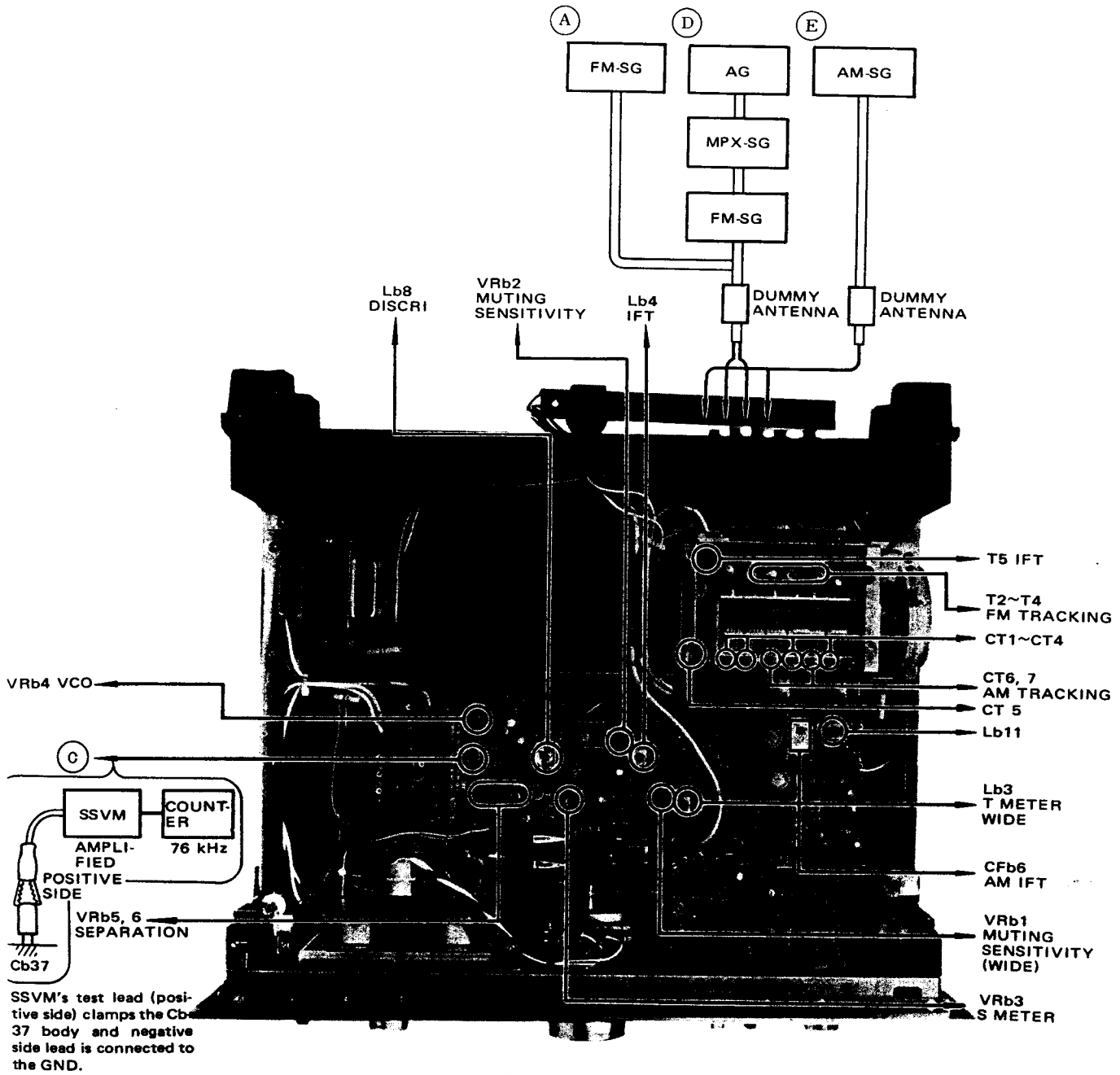

SPECIFICATIONS

FM TUNER SECTION (I.H.F.)

Usable Sensitivity		9.8 dBf	(1.7 μ V)
50 dB Quieting Sensitivity			
(Mono)		14.1 dBf	(2.8 μ V)
(Stereo)		36.1 dBf	(35 μ V)
Signal to Noise Ratio			
(Mono)		75 dB	
(Stereo)		70 dB	
Total Harmonic Distortion		at WIDE	at NARROW
Mono at	100 Hz	0.08%	0.1%
	1,000 Hz	0.08%	0.2%
	6,000 Hz	0.08%	0.3%
	15,000 Hz	0.15%	0.15%
Stereo at	100 Hz	0.13%	0.4%
	1,000 Hz	0.1%	0.3%
	6,000 Hz	0.1%	0.3%
	15,000 Hz	0.5%	1.5%
Capture Ratio		1.0 dB	2.0 dB
Alternate Channel Selectivity		30 dB	100 dB (400 kHz) 60 dB (300 kHz)
Stereo Separation			
at 1,000 Hz		50 dB	45 dB
at 50 to 1,000 Hz		43 dB	38 dB
at 15,000 Hz		40 dB	30 dB
Frequency Response		20 Hz to 15,000 Hz +0.2 dB -1.5 dB	
Spurious Response Ratio		110 dB	
Image Response Ratio		105 dB	
IF Response Ratio		110 dB	
AM Suppression Ratio		60 dB	
Sub Carrier Product Ratio		65 dB	
Antenna Impedance		300 ohms balanced & 75 ohms unbalanced	
FM Frequency Range		88 MHz to 108 MHz	
Output Level			
at 400 Hz 100% Mod	Fixed	0.75V,	1.2 kohms
	Variable	0~1.5V,	1.2 kohms
Multipath Output	Vertical	0.2V,	5 kohms
	Horizontal	0.3V,	5 kohms
FM DET. Out		0.3V,	5 kohms

AM TUNER SECTION

Usable Sensitivity		14 μ V
Signal to Noise Ratio		50 dB
Total Harmonic Distortion		0.5%
Image Rejection		60 dB
Selectivity		35 dB
Output Level	Fixed	0.15V
	Variable	0~0.3V

GENERAL

Power Requirement		60 Hz 120V (U.S.A. and Canada model) or 50~60 Hz 110~120/220~240V switchable
Power Consumption		20 watts
Dimensions		W 16-15/16" (430 mm) H 5-7/8" (149 mm) D 14-27/32" (377 mm)
Weight	(Net)	16.8 lbs. (7.6 kg)
	(Gross)	19.4 lbs. (8.8 kg)

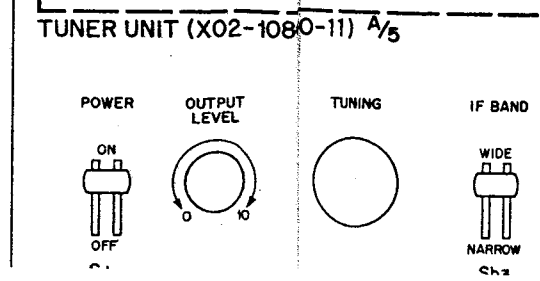
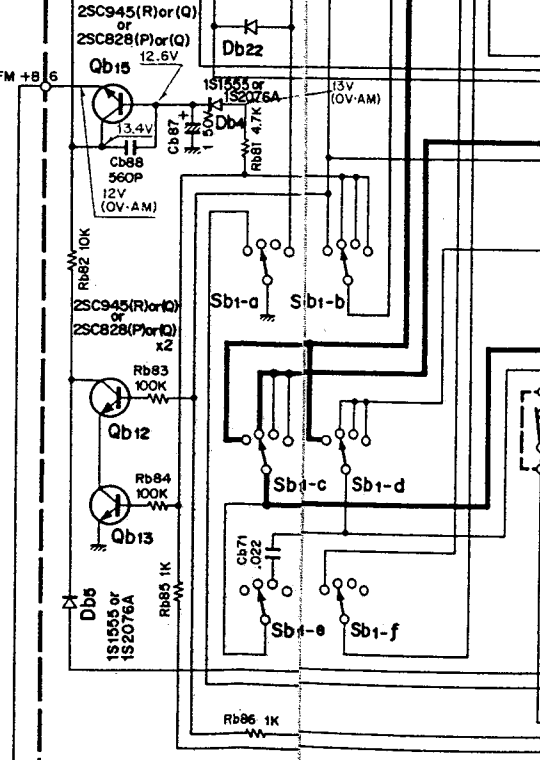
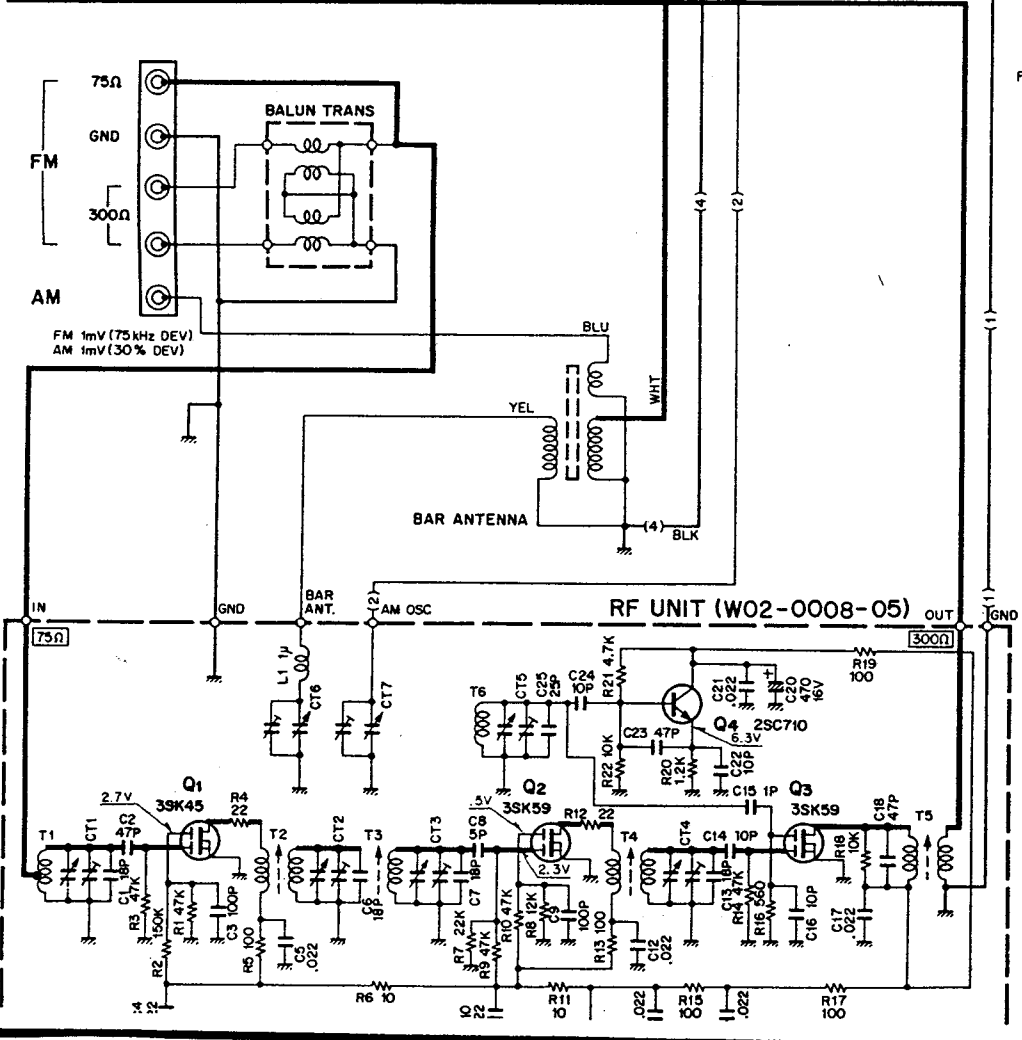
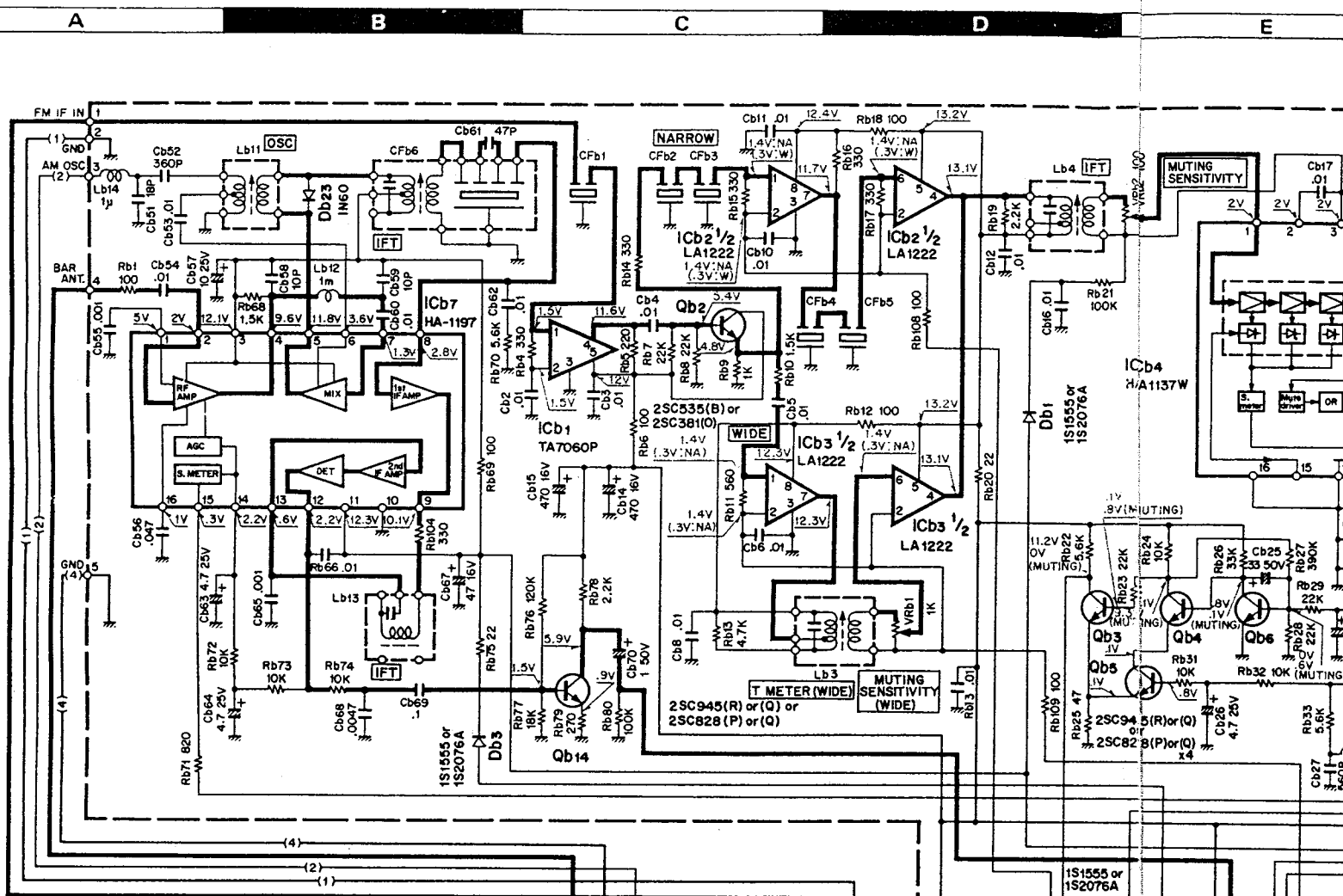

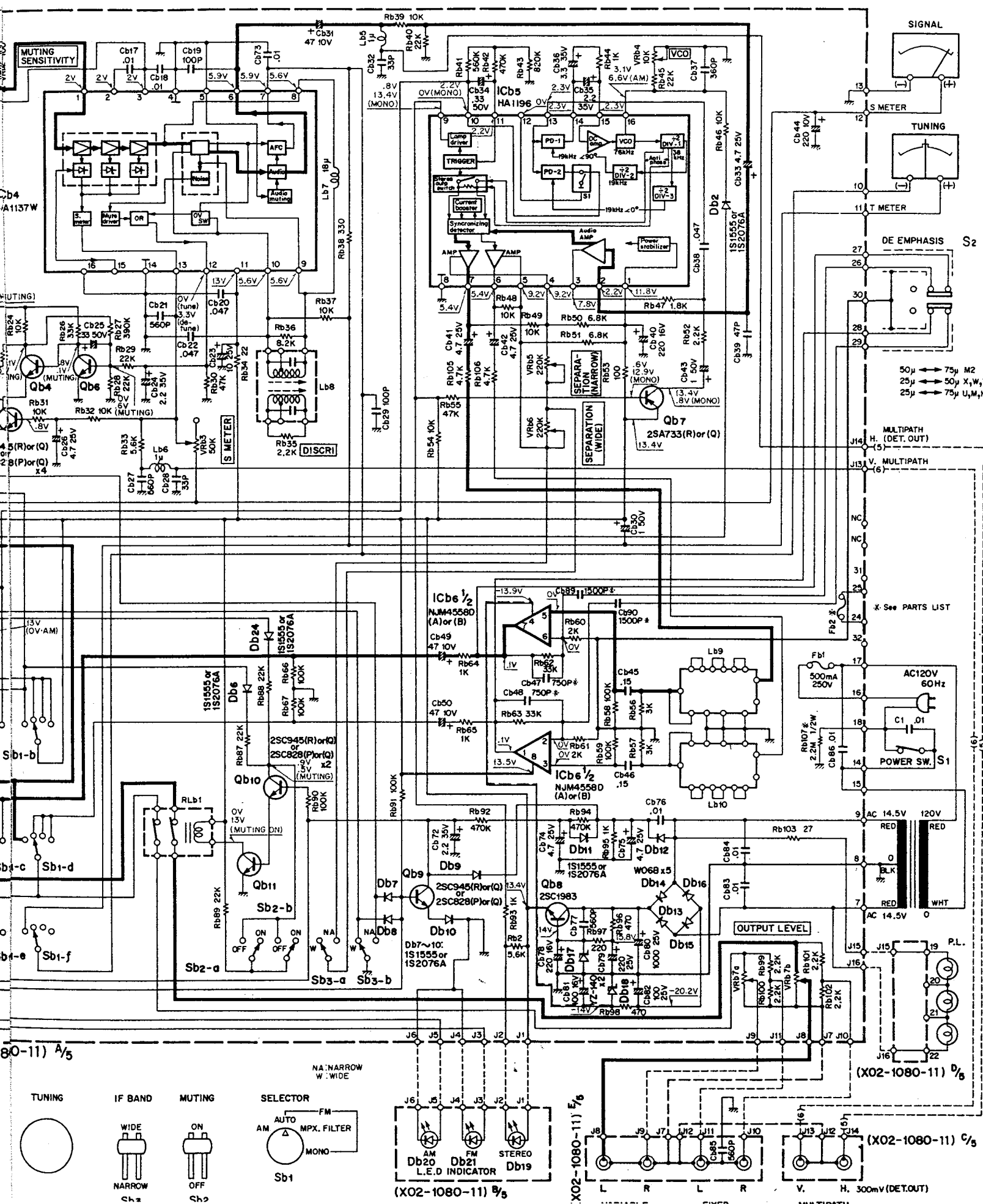

MUTING SENSITIVITY

(MUTING)

Sb1-b

Sb1-c

Sb1-e

(X02-1080-11) A₅

TUNING

IF BAND

WIDE

NARROW

MUTING

ON

OFF

SELECTOR

AUTO

FM

MONO

MPX. FILTER

Sb1

(X02-1080-11) B₅

AM

FM

STEREO

(X02-1080-11) E₆

L

R

L

R

(X02-1080-11) C₅

V.

H.

300mV (DET.OUT)

50μ → 75μ M2
25μ → 50μ X₁W₁
25μ → 75μ U₁M₁

X- See PARTS LIST

(X02-1080-11) D₆

(X02-1080-11) C₅

(X02-1080-11) C₅

(X02-1080-11) C₅

(X02-1080-11) C₅

PC BOARD

TUNER (X02-1080-11)

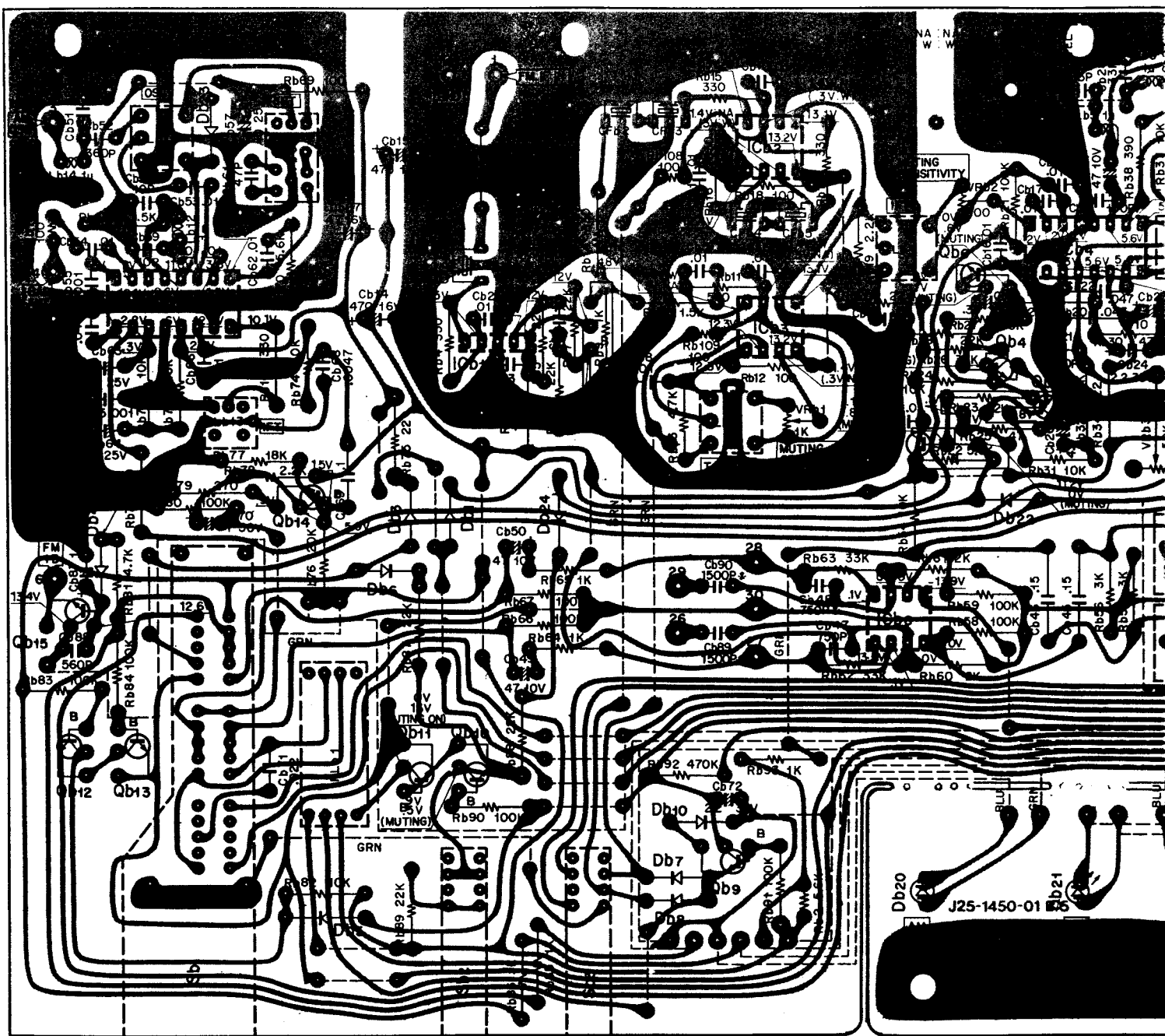

Qb2: 2SC535(B) or 2SC381(O), Qb3~6, 9~15: 2SC945(R) or (Q) or 2SC828(P) or (Q), Qb7: 2SA733(R) or (Q), Qb8: 2SC1983, ICb1: TA7060P, ICb1~11, 22, 24: 1S1555 or 1S2076, Db12~16: W06B, Db17, 18: YZ140, Db19~21: GD-4-203CD, Db23: 1N60

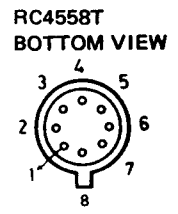
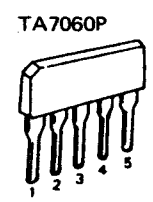
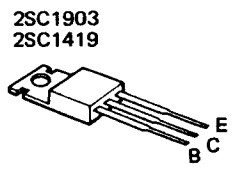
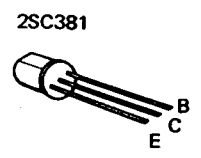
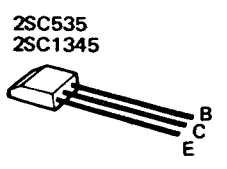
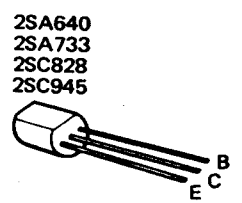
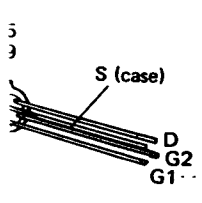

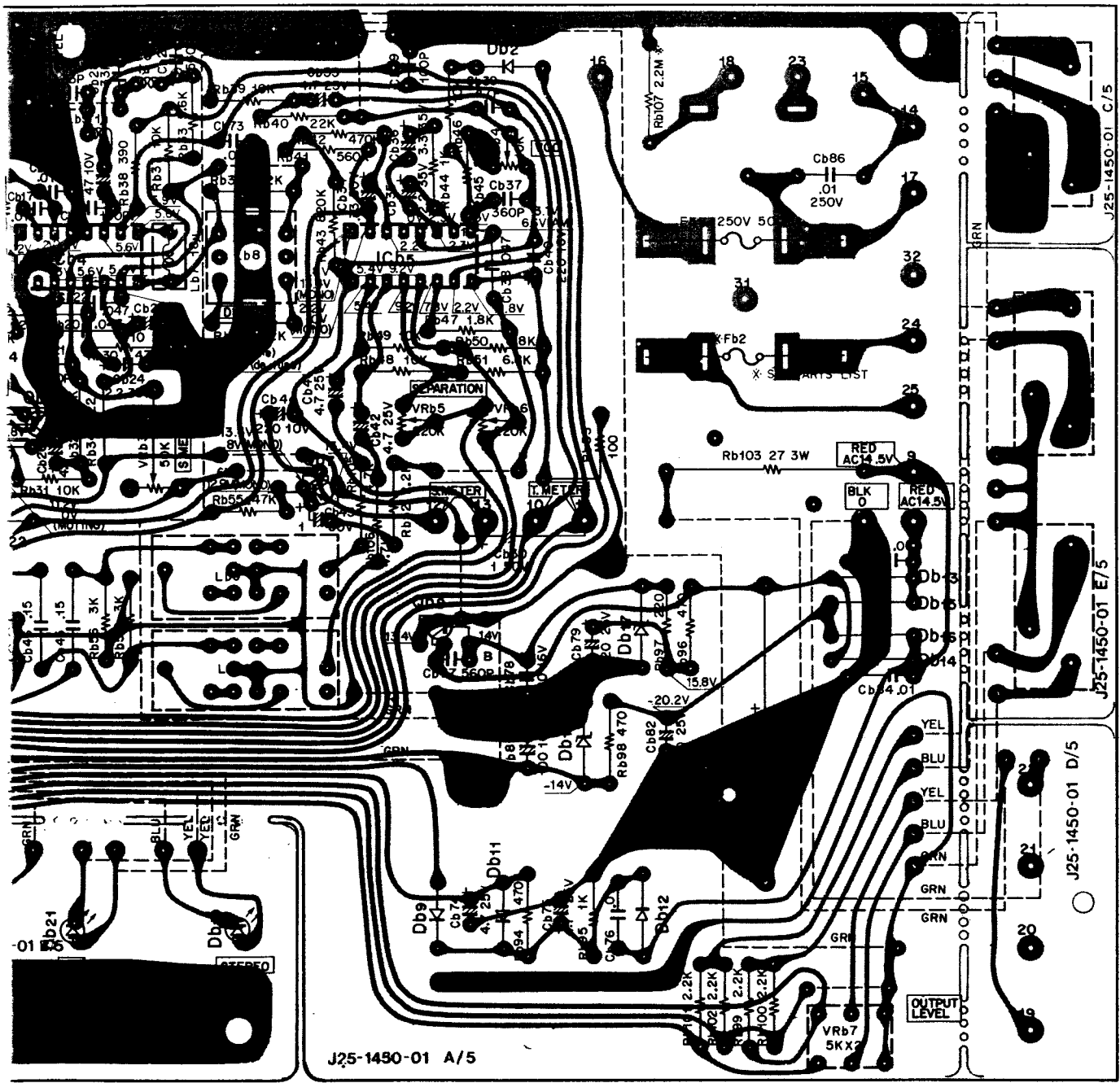

b1: TA7060P, ICb2,3: LA1222, ICb4: HA1137W, ICb5: HA1196, ICb6: NJM4558D(A)or(B), ICb7: HA1197

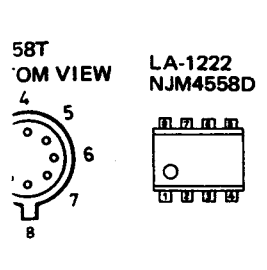

HA-1137W
HA-1196
HA-1197

