

KENWOOD

KX-31 KX-31B

STEREO CASSETTE DECK

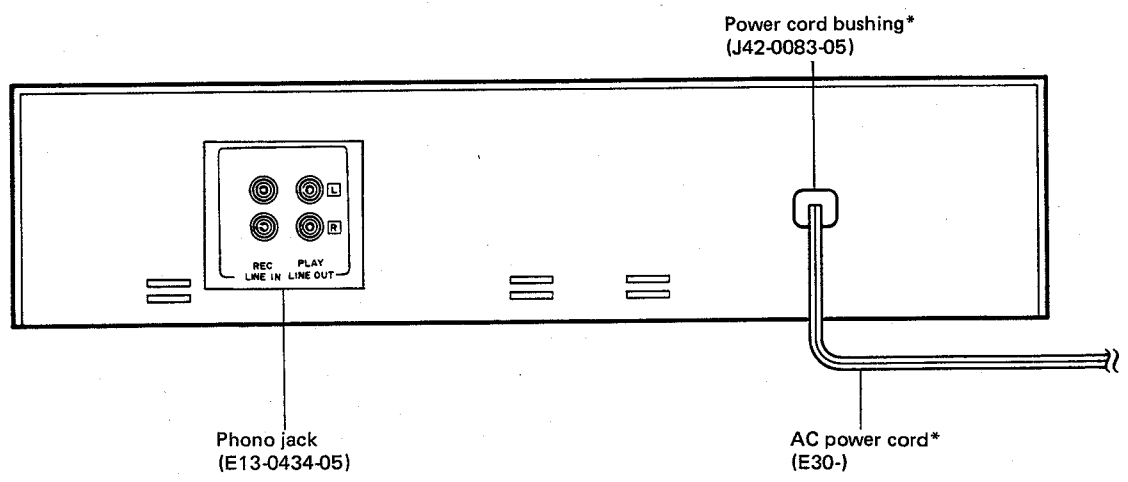
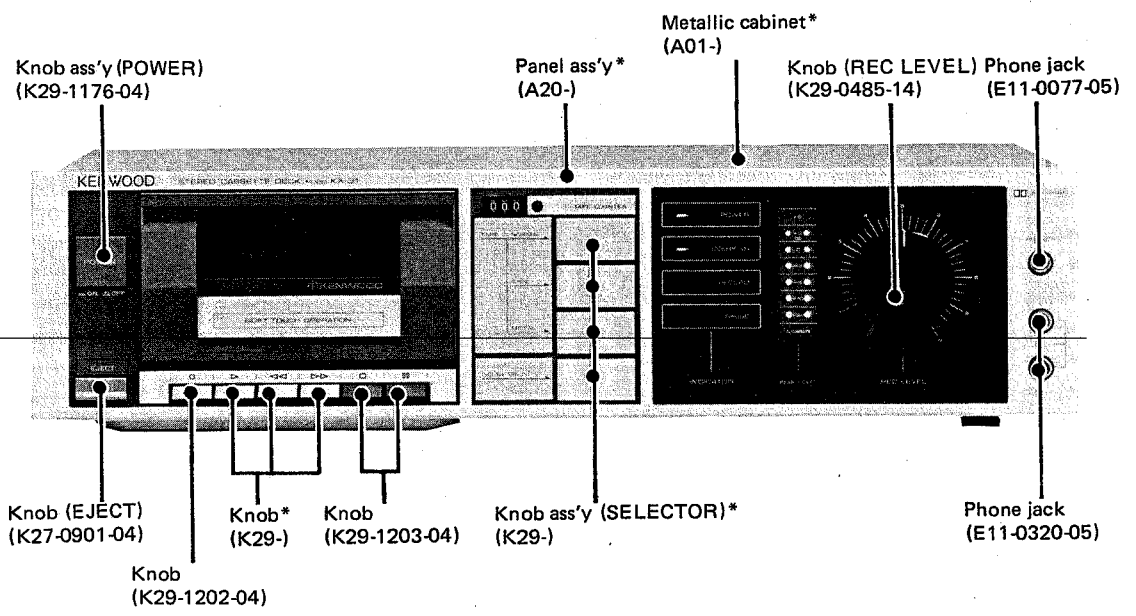

*Refer to parts list on page 13.

ADJUSTMENT

1 Notes for Adjustments

- a) **Load resistance:** A pure resistance load of 100 kΩ should be connected to the LINE OUTPUT terminal.
- b) **Standard level:** 0 dBs = 0.775 V
- c) The electrical system should be adjusted by dividing it into playback and recording.
Adjustment of recording requires perfect performance of the playback system.
No special adjustment should be required unless inner components are replaced.
- d) When the head is replaced, its stray magnetism must be completely erased by the demagnetizer prior to mounting the tape.
- e) Unless otherwise designated, measurement should be carried out with the Dolby NR switch off.

2 Test Instruments, Tools and Jigs

- AC voltmeter (High input impedance)
- Audio signal generator: AG
- Oscilloscope
- Frequency counter
- Wow and flutter meter
- Weighting filter
(ASA A characteristic with NAB curve)
- Band pass filter (Center frequency: 125 Hz, 1 kHz;
Attenuation: 18 dB/oct. or more)
- Cassette type torque gage (TW-2111: T99-0208-00)
- Spring balance
- Torque dial
- Head demagnetizer
- Cleaning tape (T93-0014-05)
- Mirror tape (T93-0021-00)

3 Test Tapes

- a) Test tapes for recording section adjustment
Normal: KENWOOD ND-60, TDK AD C-60
CrO₂: KENWOOD CD-60, TDK SA C-60
Metal: KENWOOD MD-60, TDK MA C-60

- b) Test tapes for playback section adjustment
Tape speed and wow and flutter:
TEAC MTT-111 (T93-0015-00)
Frequency characteristic and azimuth:
TEAC MTT-256 (T93-0025-00)

4 Meaning of Technical words

- a) **Standard playback condition:** The state obtained by reproducing the reference level 315 Hz signal (160 pWb/mm) of the test tape and by adjusting the playback level so that the standard output level (-9 dBs = 0.275 V) can be obtained at the LINE OUTPUT terminal.
- b) **Standard recording condition:** The state obtained by applying the 1 kHz signal to the LINE INPUT jack at the normal input level (-10 dBs) and by adjusting the RECORD LEVEL volume control so that recording can be carried out at the normal recording level.
- c) **Standard recording level:** A level to obtain residual magnetic flux of 160 pWb/mm on the standard recording tape, which is 6 dB below the level 315 Hz, 0 dB (160 pWb/mm) of the test tape (MTT-256).
- d) **Standard input level:** The standard input level necessary for obtaining the normal recording level. The levels at respective input jacks are as specified below.
MIC -58 dBs (0 VU)
LINE INPUT -20 dBs (0 VU)
- e) **Standard output level:** The standard signal level obtained at the LINE OUTPUT jack when the reference level 315 Hz signal is reproduced from the test tape.
MTT-256 315 Hz (160 pWb/mm)
Output level: -9 dBs

Note:
DOLBY and the double-D symbol are trademarks of Dolby Laboratories Licensing Corporation.
Noise reduction circuit made under license from Dolby Laboratories Licensing Corporation.

TEST TAPE SPECIFICATIONS

MODEL	TITLE	TIME CONSTANT	DESCRIPTION		APPLICATION
			FREQ/LEVEL	PROGRAM	
MTT-111	FLUTTER	—	3 kHz -10 dB		Tape Speed Test Wow and flutter Test
MTT-256	FREQUENCY	3180 μs and 120 μs	315 Hz ~ 14 kHz 0 dB / -20 dB 0 dB = DIN REFERENCE LEVEL -4 dB		FREQUENCY Response Test

ADJUSTMENT

NO.	ITEM	INPUT SETTINGS	OUTPUT SETTINGS	CASSETTE TAPE DECK SETTINGS	ALIGNMENT POINTS	ALIGN FOR	FIG.
CASSETTE DECK SECTION							
REC/PLAY HEAD							
[1]	DEMAGNETIZATION	-	-	POWER: OFF Remove the cassette door.	REC/PLAY head	Demagnetize the REC/PLAY head with a head demagnetizer.	
[2]	CLEANING	-	-	PLAY	REC/PLAY head erase head, capstan, pinch roller	Clean the REC/PLAY head erase head, capstan and pinch roller using a cotton swab slightly damped with alcohol.	
[3]	AZIMUTH	MTT-256 10 kHz -20 dB	(A)	PLAY	Azimuth adjustment screw	Adjust the azimuth adjustment screw so that both channel output levels are maximized, then lock the screw with adhesive.	(a)
DC MOTOR							
(i)	TAPE SPEED	MTT-111	(B)	PLAY	Trimming potentiometer in the DC motor (for capstan drive)	Frequency: 3000 Hz	(b)
PC BOARD (X28-1500-10)							
(1)	PLAYBACK LEVEL	MTT-256 315 Hz 0 dB	(A)	PLAY	VR3 (L) VR4 (R)	Output level: -9 dBs	
(2)	RECORD LEVEL	(C) 1 kHz -10 dBs	(A)	Rec → Playback	VR5 (L) VR6 (R)	Adjust LINE REC LEVEL potentiometer so that the output at LINE OUT of -9 dBs is obtained. After recording, playback and check so that the output of LINE OUT is -9 dBs.	
(3)	BIAS CURRENT	(C) 1 kHz, -30 dBs 10 kHz, -30 dBs	(A)	Record 1 kHz, 10 kHz signal alternately and playback.	VR7(L) VR8(R)	Adjust VR7 (VR8) so that the playback output level of 10 kHz is equal to that of 1 kHz.	
(4)	LED PEAK LEVEL METER	(C) 1 kHz -10 dBs	(A)	REC PAUSE	VR9 (L) VR10 (R)	Adjust LINE REC LEVEL so that output at LINE OUT of -9 dBs is obtained. Adjust VR9 (VR10) so that 0 dB LED segment is completely lit.	

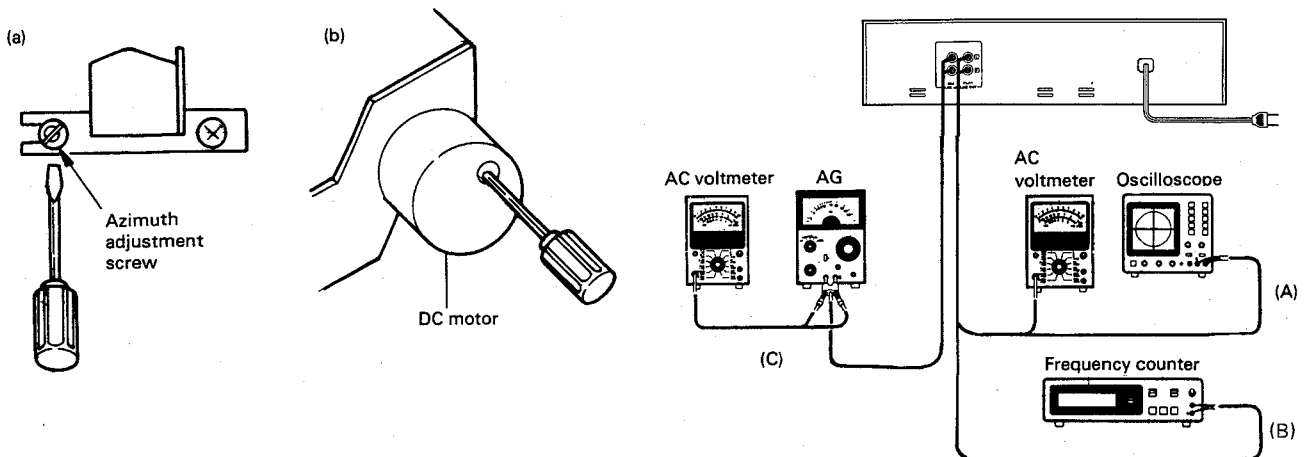

REGLAGES

1 Remarques concernant les réglages

- a) **Résistance de charge:** Connecter une charge de résistance pure de 100 kΩ à la borne de SORTIE DE LIGNE.
- b) **Niveau standard:** 0 dBs = 0.775 V
- c) Ajuster le système électrique en le divisant en une reproduction et un enregistrement.
L'ajustage de l'enregistrement nécessite une performance parfaite du système de reproduction.
Aucun ajustage spécial n'est nécessaire à moins que des composants intérieurs soient remplacés.
- d) Lorsque la tête de lecture est remplacée; son magnétisme parasite doit être effacé complètement avec un appareil de démagnétisation avant de poser la bande.
- e) Sauf si indiqué autrement, la mesure doit être effectuée avec l'interrupteur Dolby NR mis hors circuit.

2 Appareillages de Mesure, Outils et Gabarits

- Voltmètre CA (Impédance d'entrée élevée)
- Générateur audio fréquences
- Oscilloscope
- Fréquence-mètre
- Fluctuomètre
- Filtre de pondération (courbe ASA A avec courbe NAB)
- Filtre passe-bande (fréquence moyenne: 125 Hz, 1 kHz Atténuation: 18 dB/oct. ou plus)
- Cassette de mesure de couple (TW-2111: T99-0208-00)
- Peson
- Torsiomètre
- Démagnétiseur
- Bande de nettoyage (T93-0014-05)
- Bande miroir (T93-0021-00)

3 Bandes d'essai

- a) Bandes d'essai pour réglage de la section enregistrement
Normal: KENWOOD ND-60, TDK AD C-60
CrO₂: KENWOOD CD-60, TDK SA C-60
Metal: KENWOOD MD-60, TDK MA C-60

- b) Bandes d'essai pour réglage de la section lecture vitesse de défilement et pleurage et scintillement:
TEAC MTT-111 (T93-0015-00)
Réponse en fréquence et azimut:
TEAC MTT-256 (T93-0025-00)
Conditions d'enregistrement quand un signal d'entrée

4 Signification des Termes Techniques

- a) **Condition de reproduction normale:** L'état obtenu par la reproduction du signal au niveau de référence de 315 Hz (160 pWb/mm) de la bande d'essai et par l'ajustage du niveau de reproduction de telle façon que le niveau de sortie normal (-9 dBs = 0,275 V) puisse être obtenu à la borne de SORTIE DE LIGNE.
- b) **Condition d'enregistrement normale:** L'état obtenu par l'application du signal de 1 kHz au jack d'ENTREE DE LIGNE au niveau d'entrée normal (-10 dBs) et par l'ajustage de la commande de volume du NIVEAU D'ENREGISTREMENT de sorte que l'enregistrement puisse être effectué au niveau d'enregistrement normal.
- c) **Niveau d'enregistrement normal:** Un niveau pour obtenir un flux magnétique résiduel de 160 pWb/mm sur la bande d'enregistrement standard qui est de 6 dB plus bas que le niveau de 315 Hz, 0 dB (160 pWb/mm) de la bande d'essai (MTT-256).
- d) **Niveau d'entrée normal:** Le niveau d'entrée normal nécessaire pour obtenir le niveau d'enregistrement normal. Les niveaux aux jacks d'entrée respectifs sont indiqués ci-dessous.
MICROPHONE - 58 dBs (0 VU)
ENTREE DE LIGNE - 20 dBs (0 VU)
- e) **Niveau de sortie normal:** Le niveau de signal normal obtenu au jack de SORTIE DE LIGNE lorsque le signal au niveau de référence de 315 Hz est reproduit de la bande d'essai.
MTT-256 315 Hz (160 pWb/mm)
Niveau de sortie: - 9 dBs

Remarque:

La marque DOLBY et le double "D" sont des marques déposées des Dolby Laboratories.
Le système de réduction du bruit de fond est fabriqué sous licence des Dolby Laboratories.

SPECIFICATIONS DE LA BANDE

MODELE	TITRE	CONSTANTE DE TEMPS	DESCRIPTION		APPLICATION
			FREQ./NIVEAU	PROGRAMME	
MTT-111	FLUTTER	—	3 kHz -10 dB		Vitesse de défilement Pleurage et scintillement
MTT-256	FREQUENCY	3180 μs et 120 μs	315 Hz ~ 14 kHz 0 dB / -20 dB 0 dB = Niveau de référence DIN -4 dB		Réponse en fréquence Azimut

REGLAGES

N°	ITEM	REGLAGE DE L'ENTREE	REGLAGE DE LA SORTIE	REGLAGE DU MAGNETOPHONE A CASSETTE	POINTS L'ALIGNMENT	ALIGNER POUR	FIG.
SECTION DU MAGNETOPHONE							
TAPE SELECTEUR DE TYPE DE BAND: NORMAL							
TETE DE ENREGISTREMENT/LECTURE							
[1]	DEMAGNETISATION	-	-	POWER: OFF Éloigner la porte.	Tête de ENREGISTREMENT/LECTURE.	Demagnettiser la tête de ENREGISTREMENT/LECTURE avec un démagnétiseur de tête.	
[2]	NETTOYAGE	-	-	PLAY	Tête de ENREGISTREMENT/LECTURE. Tête de effacement, cabestan, Galet-presser.	Nettoyer la tête de ENREGISTREMENT/LECTURE, la tête déffacement, le cabestan et le galet-presser avec un coton-tige légèrement imbibé alcool.	
[3]	AZIMUT	MTT-256 10 kHz -20 dB	(A)	PLAY	Vis d'azimut	Régler la vis d'azimut en sorte que les deux niveaux de sortie de canal soient au maximum, puis bloquer la vis avec l'adhésif.	(a)
MOTEUR CC							
(i)	VITESSE DE DEFILEMENT	MTT-111	(B)	PLAY	Résistance ajustable du moteur CC (pour entraînement du cabestan)	Fréquence: 3000 Hz	(b)
PLAQUE IMPRIMEE (X28-1500-10)							
(1)	NIVEAU DE LECTURE	MTT-256 315 Hz 0 dB	(A)	PLAY	VR3 (G) VR4 (D)	Niveau de sortie: -9 dBs	
(2)	NEVEAU D'ENREGISTREMENT	(C) 1 kHz -10 dBs	(A)	Enregistrement → Lecture	VR5 (G) VR6 (D)	Régler le potentiomètre LINE REC LEVEL de façon à obtenir une LINE OUT de -9 dBs. Après l'enregistrement faire la lecture et vérifier que la LINE OUT soit comprise entre -9 dBs.	
(3)	COURANT DE POLARISATION	(C) 1 kHz, -30 dBs 10 kHz, -30 dBs	(A)	Enregistrer alternativement les signaux de 1 kHz et 10 kHz, puis faire la lecture.	VR7(G) VR8(D)	Régler VR7 (VR8) en sorte que le niveau de sortie de lecture de 10 kHz égale celui de 1 kHz.	
(4)	INDICATEUR DE NIVEAU DE CRETE A DIODE LED	(C) 1 kHz -10 dBs	(A)	REC PAUSE	VR9 (G) VR10 (D)	Réguler LINE REC LEVEL de façon qu'on puisse obtenir LINE OUT de -9dBs. Ajuster VR9 (VR10) de façon que le segment de diode LED 0 dB soit complètement allumé.	

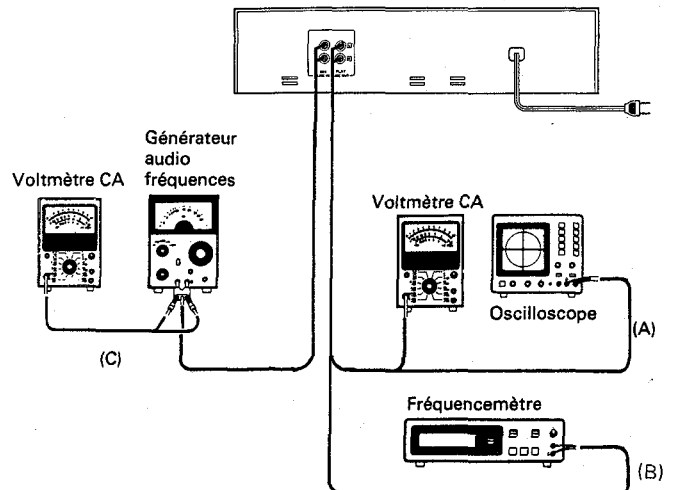
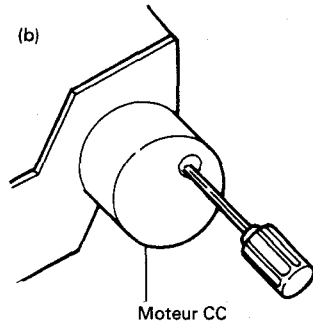
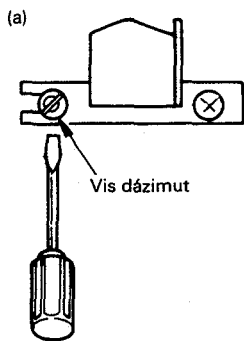

ABGLEICH

1 Hinweise für Abgleich

- a) **Belastungswiderstand:** Eine reine Widerstandsbelastung von 100 kΩ an die LINIENAUSGANGS-Klemme anschließen!
- b) **Standardpegel:** 0 dBs = 0,775 Volt
- c) Das elektrische System durch seine Einteilung in Wiedergabe und Aufnahme einstellen.
Die Einstellung der Aufnahme setzt eine perfekte Leistung des Wiedergabesystems voraus.
Keine speziellen Einstellungen sollten nötig sein, ausser wenn innere Komponenten ausgewechselt werden.
- d) Beim Auswechseln des Kopfes muß sein Streumagnetismus völlig mit einem Entmagnetisierer vor dem Einlegen des Bandes gelöscht werden.
- e) Ausser wenn anders vorgeschrieben, die Messung mit dem Dolby NR Schalter in der Aus-Stellung durchführen.

2 Meß- und Prüfgeräte, Werkzeuge und Einspannvorrichtungen

- Wechselspannungsmesser (Hohe Eingangsimpedanz)
- NF-Signalgenerator
- Oszilloskop
- Frequenzzähler
- Gleichlauf- Schwankungsmesser
- Ohrkurven-Bewertungsfilter (ASA "A" mit NAB-Kurve)
- Bandpaßfilter (Mittelfrequenz: 125 Hz, 1 kHz Schwächung: 18 dB/Okt. oder mehr)
- Kassetten-Drehmomentmesser (TW-2111: T99-0208-00) (od. Bandzugmesser)
- Federwaage
- Drehmomentkala
- Tonkopf-Entmagnetisierungsdrosele
- Reinigungsband (T93-0014-05)
- Spiegelband (T93-0021-00)

3 Bezugsbänder

- a) Bezugsbänder für Abgleich von Aufnahmereil
Normalband: KENWOOD ND-60, TDK AD C-60
CrO₂ Band: KENWOOD CD-60, TDK SA C-60
Reisenband: KENWOOD MD-60, TDK MA C-60

- b) Bezugsbänder für Abgleich von Ablesungsteil Bandgeschwindigkeit und Gleichlaufschwankungen:
TEAC MTT-111 (T93-0015-00)
Frequenzgang und Kopfazimth:
TEAC MTT-256 (T93-0025-00)

4 Bedeutung der Technischen Wörter

- a) **Standardwiedergabezustand:** Der Zustand, der durch die Wiedergabe des Signals mit dem Bezugspegel von 315 Hz (160 pWb/mm) des Testbandes und durch die Einstellung des Wiedergabepegel erreicht wird und zwar so, daß der Standardausgangspegel (- 9 dBs = 0,275 V) an der LINIENAUSGANGS-Klemme erreicht werden kann.
- b) **Standardaufnahmезustand:** Der Zustand, der durch das Anbringen des 1 kHz Signals an die LINIENEINGANGS-Klemme mit dem Normaleingangspegel (- 10 dBs) und durch Einstellung des AUFNAHMEPEGEL-Reglers erreicht wird und zwar so, daß die Aufnahme bei normalem Aufnahmepegel durchgeführt werden kann.
- c) **Standardaufnahmepegel:** Ein Pegel um den Restmagnetfluß von 160 pWb/mm auf dem Standardaufnahmeband zu erreichen, der 6 dB unter dem 315 Hz, 0 dB (160 pWb/mm) Pegel des Testbandes liegt (MTT-256).
- d) **Standardeingangspegel:** Der Standardeingangspegel, der benötigt wird um den normalen Aufnahmepegel zu erreichen. Die Pegel an den respektiven Klemmen sind hier unten angegeben.
MIKROFON - 58 dBs (0 VU)
LINIENEINGANGS..... - 20 dBs (0 VU)
- e) **Standardausgangspegel:** Der Standardsignalpegel, der an der LINIENAUSGANGS-Klemme erreicht wird, wenn das Signal mit dem Bezugspegel von 315 Hz vom Testband wiedergegeben wird.
MTT-256 315 Hz (160 pWb/mm)
Ausgangspegel: - 9 dBs

Hinweis:

DOLBY und Doppel-D-Symbol sind eingetragene Warenzeichen der Dolby Laboratories. Dolby-Rauschunterdrückung mit Lizenz der Dolby Laboratories gefertigt.

TECHNISCHE DATEN DER BEZUGSBÄNDER

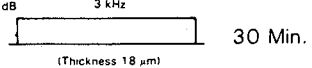
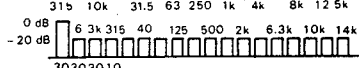
TYP	BEZEICHNUNG	ZEITKONSTANTE	BESCHREIBUNG		ANWENDUNG
			FREQ/PEGEL	PROGRAM	
MTT-111	Gleichlaufschwankungen (FLUTTER)	—	3 kHz - 10 dB	- 10 dB 3 kHz  30 Min.	Bandlaufgeschwindigkeits-Prüfung Gleichlaufschwankungs-Prüfung
MTT-256	Frequenzgang (FREQUENCY)	3180 µSek. und 120 µSek.	315 Hz ~ 14 kHz 0 dB / - 20 dB 0 dB = DIN-Bezugspegel - 4 dB		Prüfung des Frequenzgangs

ABGLEICH

NR.	GEGENSTAND	EINGANGS-EINSTELLUNG	AUSGANGS-EINSTELLUNG	KASSETTEN-GERÄT-EINSTELLUNG	ABGLEICH-PUNKTE	ABGLEICHEN FÜR	ABB.
CASSETTEN-DECK-ABTEILUNG				TAPE BANDSORTENWÄHLER: NORMAL			
AUFNAHME/WIEDERGABE-KOPF							
[1]	ENTMAGNETISIERUNG	-	-	POWER: OFF Den Kassettenfachdeckel oben herausziehen.	AUFNAHME/WIEDERGABE-Kopf	Entmagnetisierung von dem AUFNAHME/WIEDERGABE-Kopf mit einem Tonkopf Entmagnetisierungsdrössel.	
[2]	REINGUNG	-	-	PLAY	AUFNAHME/WIEDERGABE-Kopf, Löschkopf, Tonwelle, Andruckrolle	AUFNAHME/WIEDERGABE-Kopf, Löschkopf, Tonwelle und Andruckrolle mit einem leicht mit Alkohol befeuchteten Wattebausch reinigen.	
[3]	AZIMUTH-EINSTELLUNG	MTT-256 10 kHz -20 dB	(A)	PLAY	Azimuth-Einstellschraube	Einstellung von Azimuth Einstellschraube so daß beide Kanal Ausgangspegel maximal sind, dann die Schraube mit Klebstoff festlegen.	(a)
GLEICHSTROMMOTOR							
(i)	BANDGESCHWINDIGKEIT	MTT-111	(B)	PLAY	Trimmer potentiometer am Gleichstrommotor (für Tonwellen-antrieb)	Frequenz: 3000 Hz	(b)
GEDRUCKTE SCHALTPLATTE (X28-1500-10)							
(1)	WIEDERGABE-PEGEL	MTT-256 315 Hz 0 dB	(A)	PLAY	VR3 (L) VR4 (R)	Ausgangspegel: -9 dBs	
(2)	AUFNAHME-PEGEL	(C) 1 kHz -10 dBs	(A)	Aufnahme → Wiedergabe	VR5 (L) VR6 (R)	Stellen Sie LINE REC LEVEL so ein, daß man bei LINE OUT einen Ausgang von -9 dBs erhält. Drauf Aufnahme, Wiedergabe und stellen Sie sicher, daß der Ausgang von LINE OUT -9 dBs liegt. Wenn dieser Pegel nicht erreicht ist, nechstellen Sie VR5 (VR6) ein.	
(3)	LEERLAUF-STROM	(C) 1 kHz, -30 dBs 10 kHz, -30 dBs	(A)	Aufnehmen das Signal von 1 kHz und 10 kHz abwechselnd und Vorlesung	VR7(L) VR8(R)	Abgleich von VR7 (VR8) so daß der Abspiel-Ausgangspegel von 10 kHz dem von 1 kHz gleich ist.	
(4)	LED-SPITZEN-PEGELMESSER	(C) 1 kHz -10 dBs	(A)	REC PAUSE	VR9 (L) VR10 (R)	Stellen Sie LINE REC LEVEL so ein, daß man bei LINE OUT einen Ausgang von -9 dBs erhält. Stellen Sie VR9 (VR10) so ein, daß das 0 dB-Segment vollständig leuchtet.	

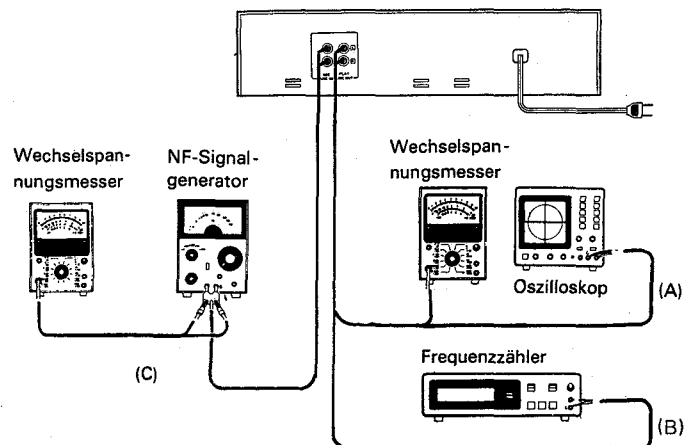
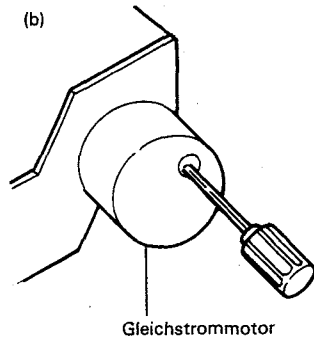
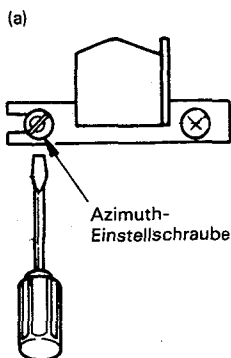

BLOCK DIAGRAM/SCHEMATIC DIAGRAM

BLOCK DIAGRAM

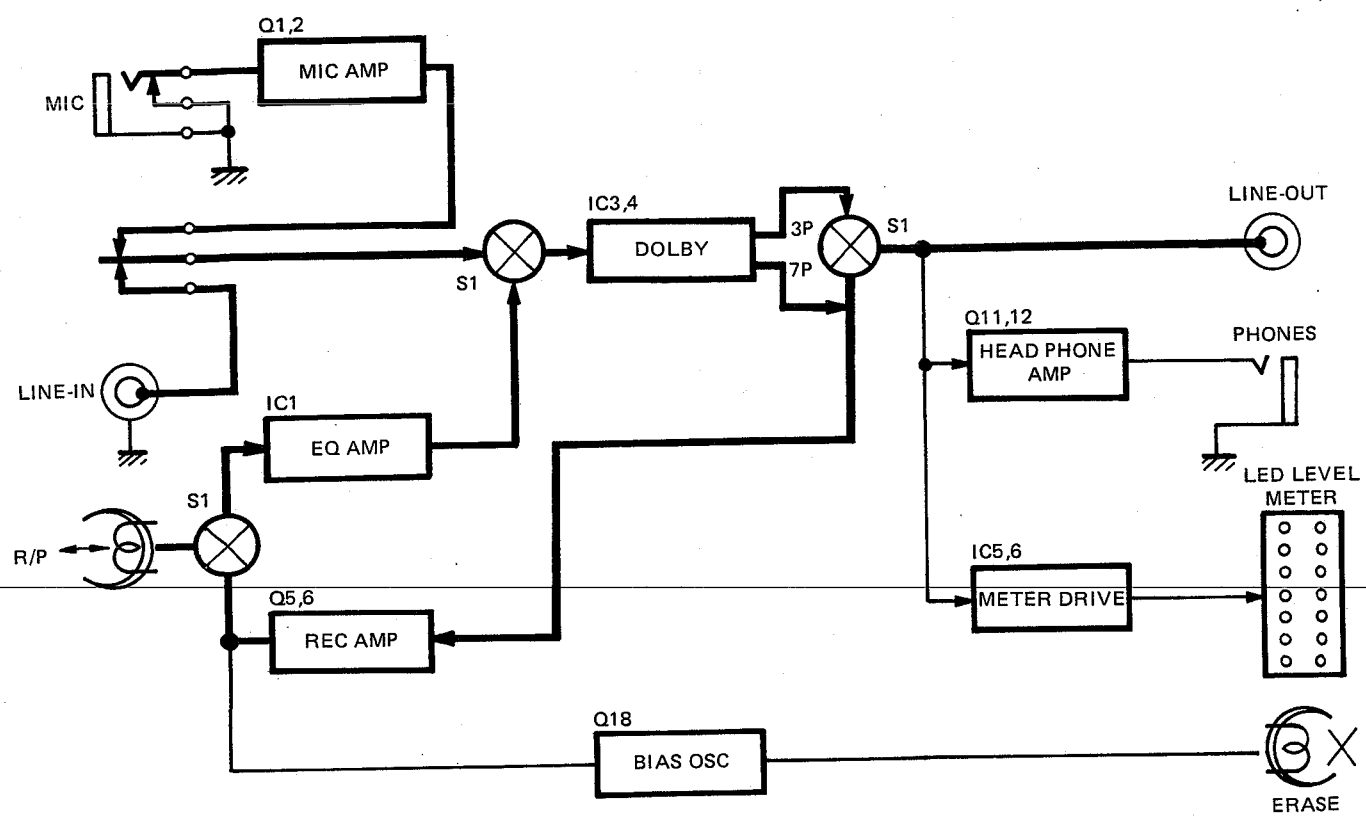

SCHEMATIC DIAGRAM

AN6882

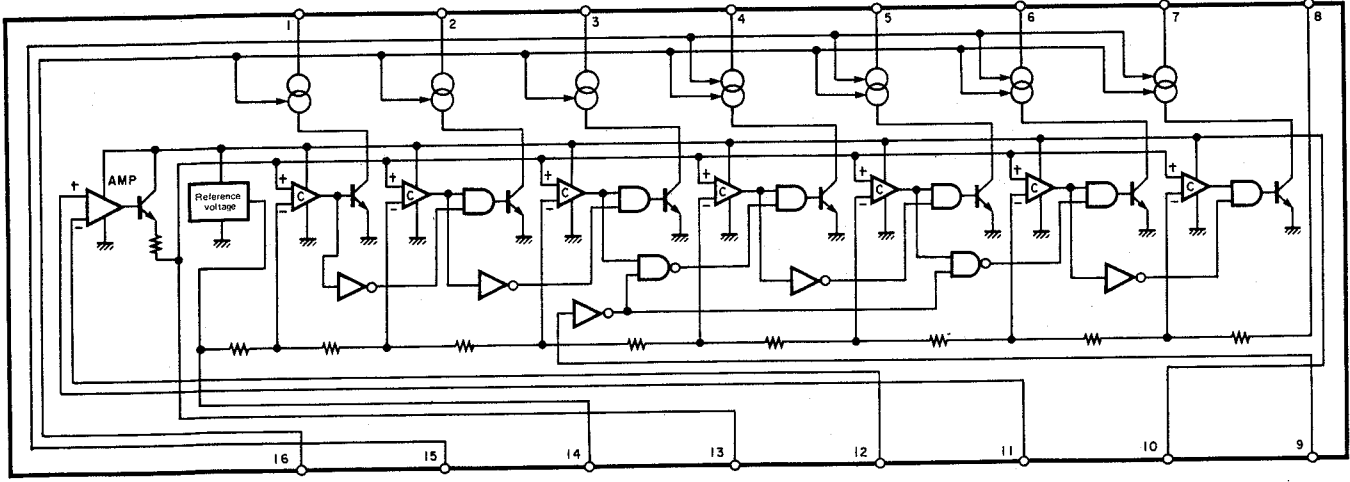

KX-31/31B KX-31/31B

EXPLODED VIEW (1)

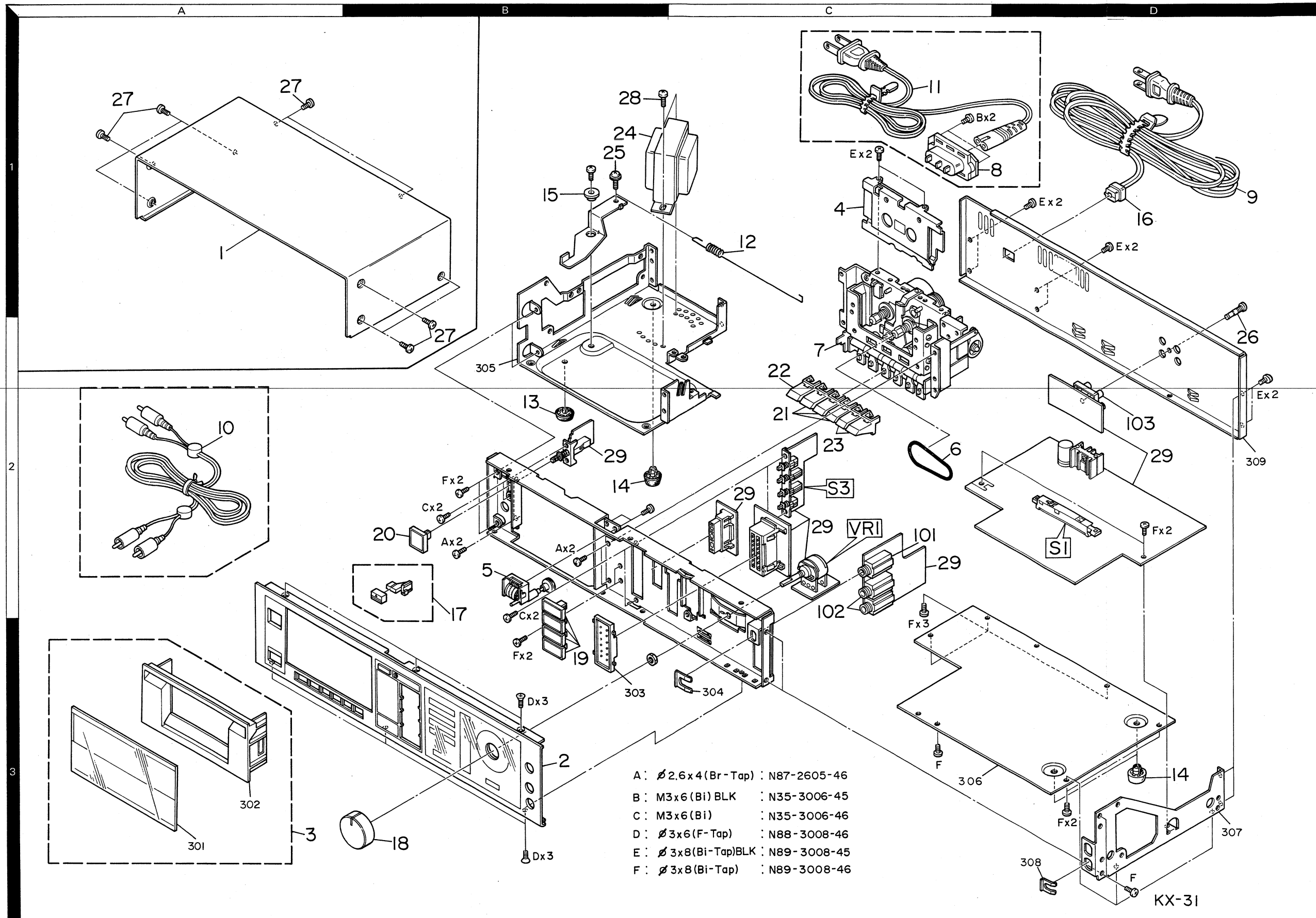

Refer to Parts List on page 13.

KX-31/31B KX-31/31B

PC BOARD

RECORD/PLAYBACK(X28-1500-10) Component side view

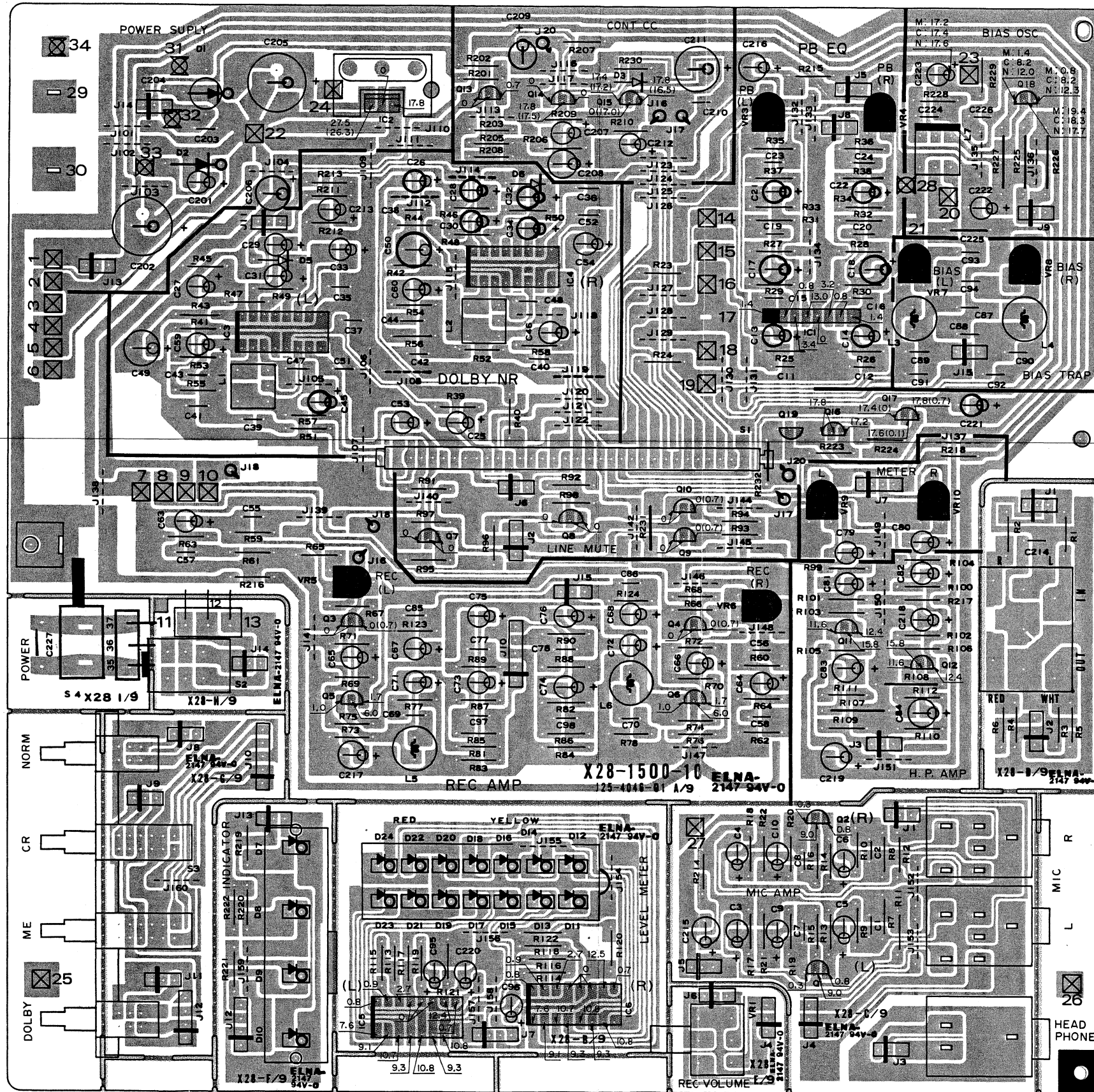

IC3 DC voltage

Pin No.	PLAY	REC
1	6.0	5.9
2	6.2	6.2
3	6.2	6.2
4	6.1	6.1
5	6.1	6.1
6	6.2	6.2
7	6.0	6.0
8	0	0
9	0	0
10	6.2	6.2
11	6.2	6.2
12	6.1	6.1
13	0	0
14	6.2	6.2
15	6.0	6.0
16	12.4	12.4

DOLBY ON

IC4 DC voltage

Pin No.	PLAY	REC
1	6.0	5.9
2	6.2	6.2
3	6.2	6.2
4	6.2	6.2
5	6.1	6.1
6	6.2	6.2
7	6.0	6.0
8	0	0
9	0	0
10	6.2	6.2
11	6.2	6.2
12	6.2	6.2
13	0	0
14	6.2	6.2
15	6.0	6.0
16	12.4	12.4

DOLBY ON

In this model, there are separated pc boards which were originally one. These separated pc boards can't be supplied independently.

Ex.	Part No. of pc board	Separated portion No.
	X09-1230-00	(A/3)
	X09-1230-00	(B/3)
	X09-1230-00	(C/3)

In the example shown above, separated portion can't be ordered independently. In case only A/3 was ordered, pc board ass'y of X09-1230-00, which all A/3, B/3, C/3 included, will be shipped.

Refer to the schematic diagram for the values of capacitors and resistors. The PC board drawing is viewed from the side easy to check.

KENWOOD

STEREO CASSETTE DECK

- 2SA733
- 2SA999
- 2SA1127NC
- 2SC945
- 2SC1685
- 2SC1845
- 2SC1980
- 2SC2060
- 2SC2320
- JA101
- KSC945C

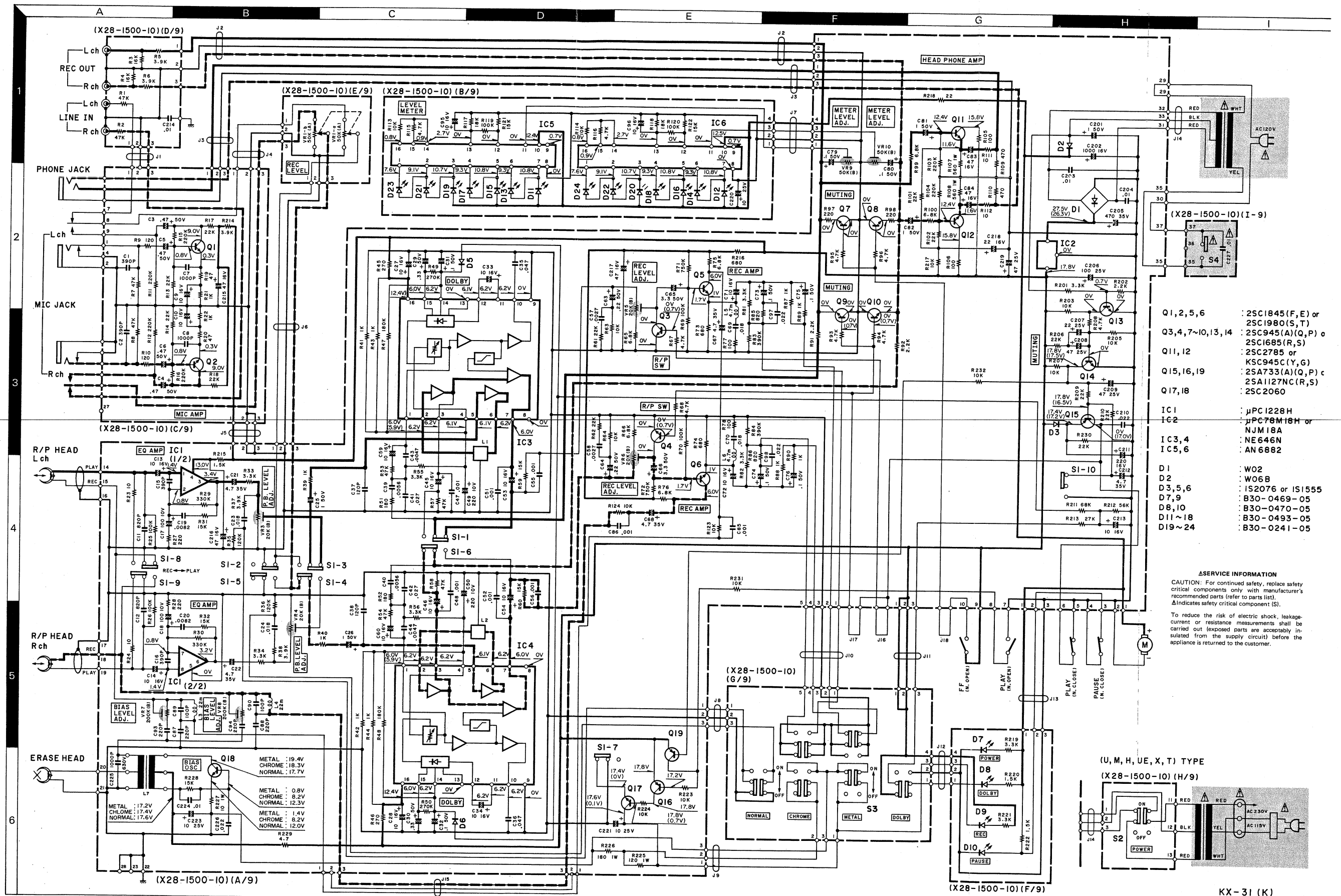
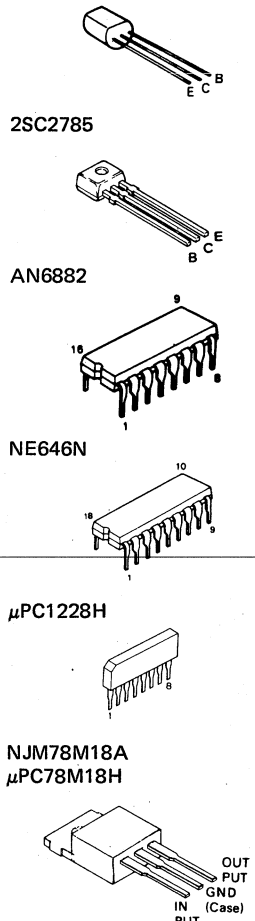

- Q1, 2, 5, 6 : 2SC1845 (F, E) or 2SC1980 (S, T)
- Q3, 4, 7-10, 13, 14 : 2SC945 (A) (Q, P) or 2SC1685 (R, S)
- Q11, 12 : 2SC2785 or KSC945C (Y, G)
- Q15, 16, 19 : 2SA733 (A) (Q, P) or 2SA1127NC (R, S)
- Q17, 18 : 2SC2060
- IC1 : μPC1228H
- IC2 : μPC78M18H or NJM18A
- IC3, 4 : NE646N
- IC5, 6 : AN6882
- D1 : W02
- D2 : W06B
- D3, 5, 6 : IS2076 or IS1555
- D7, 9 : B30-0469-05
- D8, 10 : B30-0470-05
- D11 ~ 18 : B30-0493-05
- D19 ~ 24 : B30-0241-05

SERVICE INFORMATION
 CAUTION: For continued safety, replace safety critical components only with manufacturer's recommended parts (refer to parts list).
 Δ indicates safety critical component (S).
 To reduce the risk of electric shock, leakage current or resistance measurements shall be carried out (exposed parts are acceptably insulated from the supply circuit) before the appliance is returned to the customer.

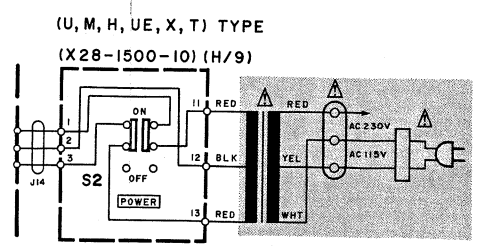

KX-31 (K)

STEREO CASSETTE DECK

KX-31/31B

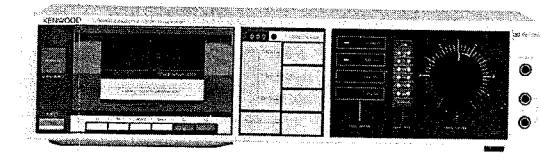
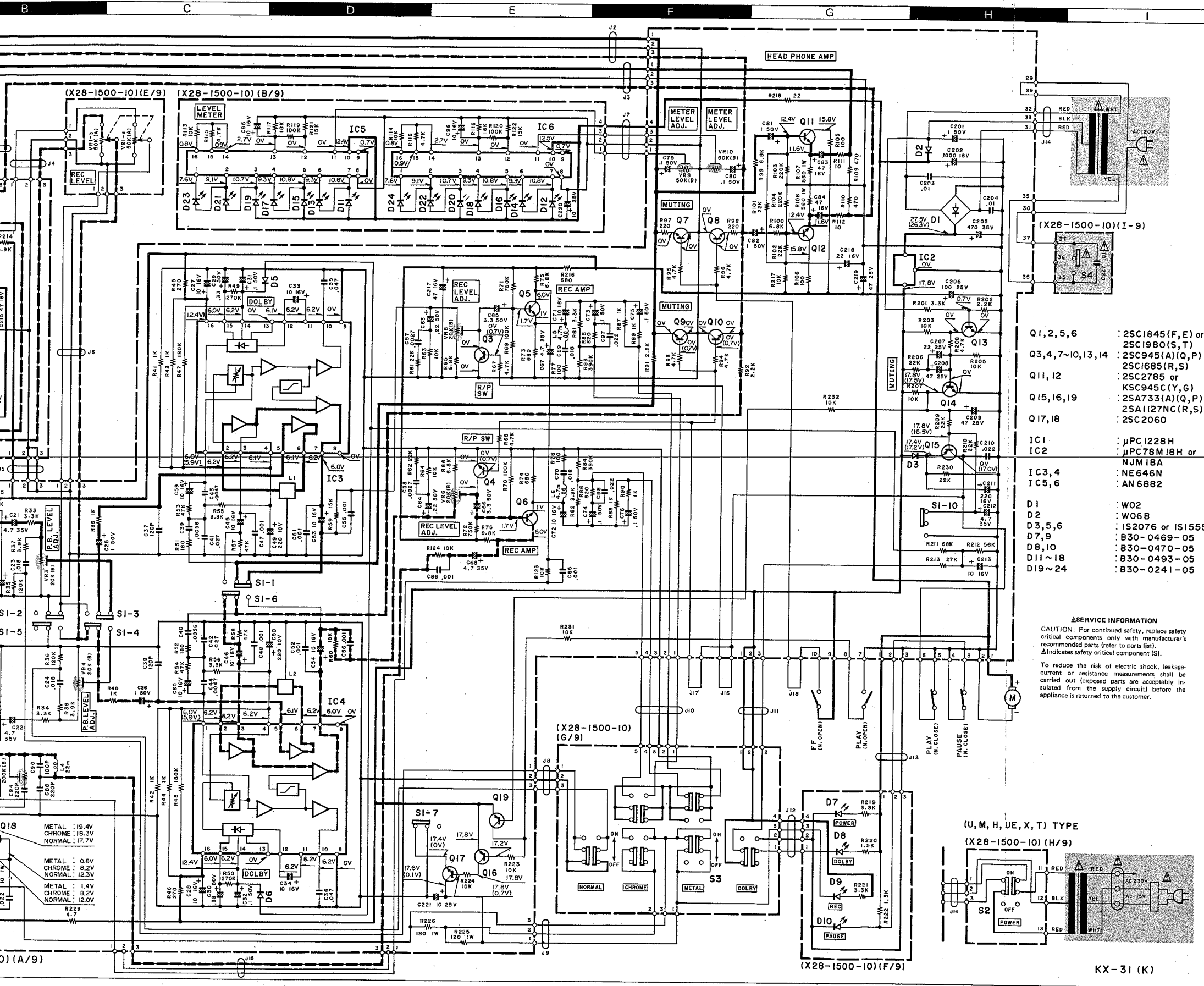

SPECIFICATION

Type	Stereo cassette deck with Dolby B NR system (KX-31)		
Track System	Stereo cassette deck with Dolby B, C NR system (KX-41)		
Recording System	4-track, 2-channel stereo/mono, recording/playback		
Erase System	AC bias system (Bias frequency: 105 kHz)		
Tape Speed	4.75 cm/sec (1-7/8 ips)		
Heads	Record and playback head x 1 (Hard permalloy with sendust guard)		
Motor	Erase head x 1 (Double gap ferrite head)		
Fast Winding Time	Electronically controlled DC single motor		
Frequency Response	Approx. 95 seconds with C-60 tape		
Normal Tape	20 Hz to 16,000 Hz (30 Hz to 15,000 Hz ± 3 dB)		
CrO ₂ Tape	20 Hz to 17,000 Hz (30 Hz to 16,000 Hz ± 3 dB)		
Metal Tape	20 Hz to 17,000 Hz (30 Hz to 16,000 Hz ± 3 dB)		
Signal-to-Noise Ratio		Dolby ON	Dolby OFF
		(KX-31)	(KX-41)
		Dolby B ON	Dolby C ON
		Dolby OFF	Dolby OFF
Normal tape:	67 dB	75 dB	57 dB
CrO ₂ tape:	67 dB	75 dB	57 dB
Metal tape:	67 dB	75 dB	57 dB
Harmonic Distortion	Less than 1.0% (at 1 kHz, 0 VU with Normal tape)		
Wow and Flutter	0.045% (W.R.M.S.)		
Input Sensitivity/Impedance:	LINE x 2: 77.5 mV/50 kohms		
	Microphones x 2: 0.7 mV/3.3 kohms		
Output Level/Load Impedance:	LINE x 2: 270 mV/50 kohms		
	Headphones x 1: 50 mV/8 ohms		
Built-in Features	Dolby B noise reduction system (KX-31)		
	Dolby B, C noise reduction system (KX-41)		
	Tape selector (Normal/CrO ₂ /Metal)		
	7.15 dB peak-to-peak meters (-20 dB to +6 dB)		
	Full auto shut off mechanism in all modes		
	Timer stand by mechanism		
	Three digit tape counter		
	Two microphone jacks		
Headphone jack	AC 120V, 60 Hz U.S.A. and Canada models		
Power Requirements	AC 120V/220-240V (Switchable), 50/60 Hz Other countries		
Power Consumption	15 watts		
Dimensions	W: 440 mm (17-5/16")		
	H: 117 mm (4-39/64")		
	D: 232 mm (9-1/8")		
	4.0 kg (8.8 lb)		
Weight	4.0 kg (8.8 lb)		
Supplied Accessories	Audio cable x 2		
	Head cleaning set x 1		
Reference Tapes	Normal: KENWOOD ND-60		
	CrO ₂ : KENWOOD CD-60		
	Metal: KENWOOD MD-60		

- Q1, 2, 5, 6 : 2SC1845 (F, E) or 2SC1980 (S, T)
- Q3, 4, 7~10, 13, 14 : 2SC945 (A, Q, P) or 2SC1685 (R, S)
- Q11, 12 : 2SC2785 or KSC945C (Y, G)
- Q15, 16, 19 : 2SA733 (A, Q, P) or 2SA1127NC (R, S)
- Q17, 18 : 2SC2060
- IC1 : μPC1228H
- IC2 : μPC78M18H or NJM18A
- IC3, 4 : NE646N
- IC5, 6 : AN6882
- D1 : W02
- D2 : W06B
- D3, 5, 6 : IS2076 or IS1555
- D7, 9 : B30-0469-05
- D8, 10 : B30-0470-05
- D11~18 : B30-0493-05
- D19~24 : B30-0241-05

⚠SERVICE INFORMATION
 CAUTION: For continued safety, replace safety critical components only with manufacturer's recommended parts (refer to parts list).
 ⚠Indicates safety critical component (S).
 To reduce the risk of electric shock, leakage current or resistance measurements shall be carried out (exposed parts are acceptably insulated from the supply circuit) before the appliance is returned to the customer.

DOLBY and the double-D symbol are trademarks of Dolby Laboratories Licensing Corporation.
 Noise reduction circuit made under license from Dolby Laboratories Licensing Corporation.
 La marque DOLBY et le double "D" sont des marques déposées des Dolby Laboratories.
 Le système de réduction du bruit de fond est fabriqué sous licence des Dolby Laboratories.
 DOLBY und Doppel-D-Symbol sind eingetragene Warenzeichen der Dolby Laboratories.
 Dolby-Rauschunterdrückung mit Lizenz der Dolby Laboratories gefertigt.

- DC voltages are as measured with a high impedance voltmeter with a cassette loaded at playback mode. Values may vary slightly due to variations between individual instruments or/and units. Bias circuit DC voltages are as measured while in the record mode.
- Les tensions c.c. doivent être mesurées avec un voltmètre à haute impédance, une cassette étant insérée en mode de lecture. Les valeurs peuvent différer légèrement du fait des variations inhérentes aux appareils et aux instruments de mesure individuels. Les tensions c.c. du circuit de polarité doivent être mesurées, l'appareil étant en mode d'enregistrement.
- Die angegebenen Gleichspannungswerte wurden bei eingesetzter Cassette in der Wiedergabe mit einem hochohmigen Voltmeter gemessen. Dabei schwanken die Meßwerte aufgrund von Unterschieden zwischen einzelnen Instrumenten oder Geräten u.U. geringfügig. Die angegebenen Gleichspannungswerte der Vormagnetisierungsschaltung wurden in der Aufnahme-Betriebsart gemessen.

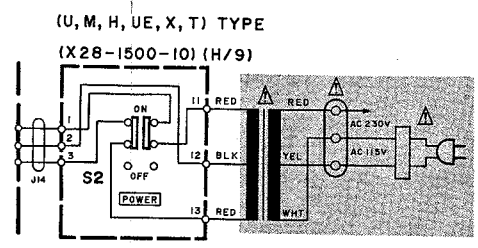

EXPLODED VIEW (2)

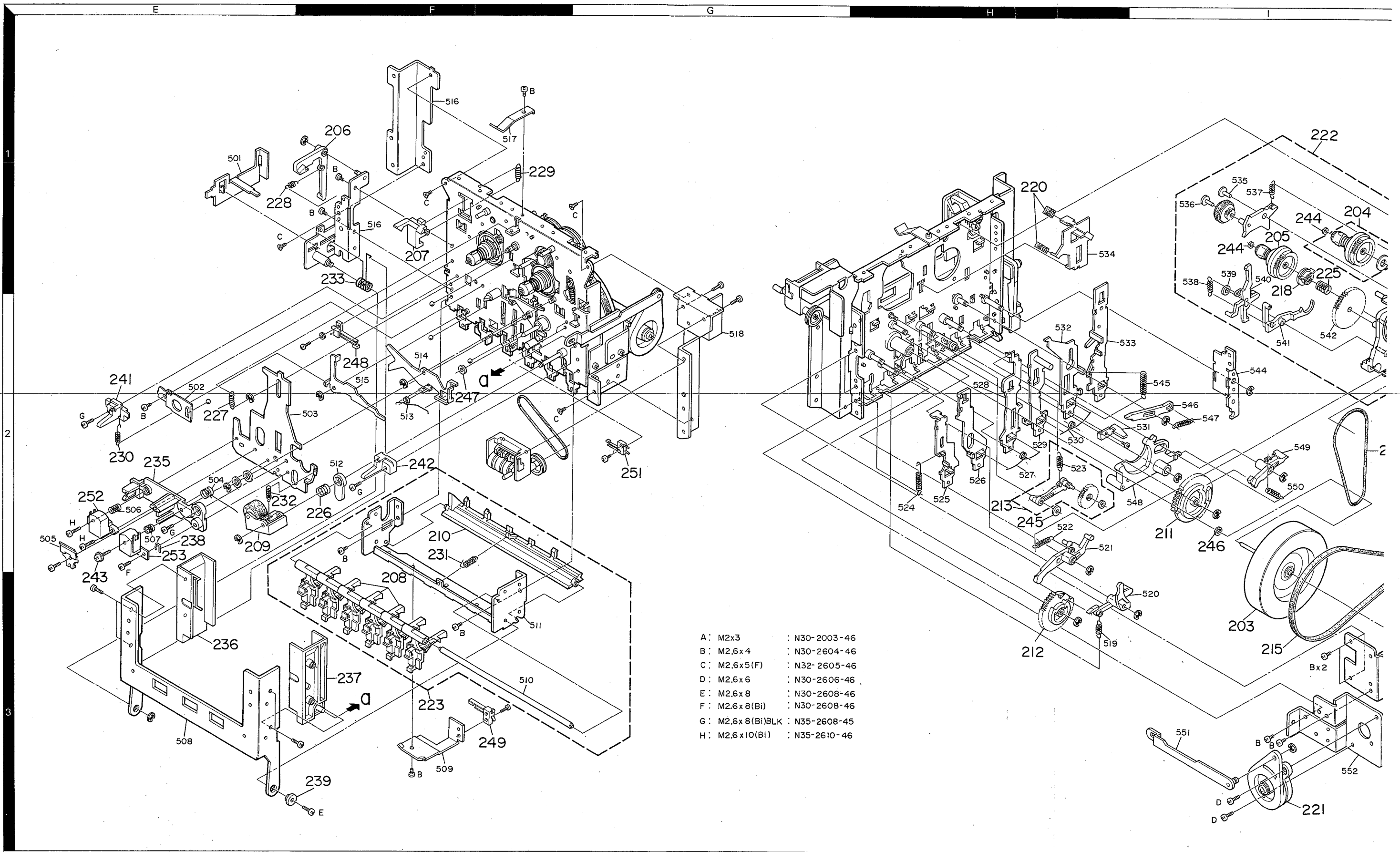

PARTS LIST

* New Parts
Parts without Parts No. are not supplied.
Les articles non mentionnés dans le Parts No. ne sont pas fournis.
Teile ohne Parts No. werden nicht geliefert.

△ Indicates safety critical component.

Ref. No.	Address	New Parts	Parts No.	Description	Destination	Remarks
参照番号	位置	新	部品番号	部品名/規格	仕向	備考
KX-31/31B						
1	1A		A01-0473-03	METALLIC CABINET	KPUMH	
1	1A		A01-0473-03	METALLIC CABINET	XTE	
1	1A		A01-0473-03	METALLIC CABINET	UE	
1	1A	*	A01-0633-03	METALLIC CABINET	K M	
1	1A	*	A01-0633-03	METALLIC CABINET	P E	
2	3B	*	A20-3375-03	PANEL ASSY	KPUMH	
2	3B	*	A20-3375-03	PANEL ASSY	UE XE	
2	3B	*	A20-3376-03	PANEL ASSY	T	
2	3B	*	A20-3524-03	PANEL ASSY	K M	
2	3B	*	A20-3524-03	PANEL ASSY	P E	
3	3A	*	A53-0056-04	CASSETTE LID ASSY	KPUMH	
3	3A	*	A53-0056-04	CASSETTE LID ASSY	XTE	
3	3A	*	A53-0056-04	CASSETTE LID ASSY	UE	
3	3A	*	A53-0080-04	CASSETTE LID ASSY	K M	
3	3A	*	A53-0080-04	CASSETTE LID ASSY	P E	
4	1C		B03-0228-03	DRESSING PLATE	K M	
4	1C		B03-0228-03	DRESSING PLATE	P E	
4	1C	*	B03-0232-03	DRESSING PLATE	KPUMH	
4	1C	*	B03-0232-03	DRESSING PLATE	XTE	
4	1C	*	B03-0232-03	DRESSING PLATE	UE	
5	2B	*	B35-0019-05	TAPE COUNTER		
-	-	-	B46-0092-03	WARRANTY CARD	K K	
-	-	-	B46-0093-03	WARRANTY CARD	P P	
-	-	-	B46-0094-03	WARRANTY CARD	UH UE	
-	-	-	B46-0095-03	WARRANTY CARD	UH UE	
-	-	-	B46-0096-03	WARRANTY CARD	X	
-	-	-	B46-0097-03	WARRANTY CARD	T	
-	-	-	B46-0098-03	WARRANTY CARD	E E	
-	-	*	B50-4564-00	INSTRUCTION MANUAL	KUH	
-	-	*	B50-4564-00	INSTRUCTION MANUAL	K UE	
-	-	*	B50-4565-00	INSTRUCTION MANUAL	PMX M	
-	-	*	B50-4565-00	INSTRUCTION MANUAL	P	
-	-	*	B50-4566-00	INSTRUCTION MANUAL	M M	
-	-	*	B50-4567-00	INSTRUCTION MANUAL	E E	
-	-	*	B50-4568-00	INSTRUCTION MANUAL	T	
-	-		B59-0092-00	SERVICE DIRECTORY	UH UE	
6	2C		D16-0076-04	BELT		
7	2C	*	D40-0262-05	MECHANISM ASSY		
△ 8	1C		E03-0102-15	AC INLET	UMHXT	
△ 8	1C		E03-0102-15	AC INLET	E M E	
△ 8	1C		E03-0102-15	AC INLET	UE	
△ 9	1D		E30-0181-05	AC POWER CORD	KP K	
△ 9	1D		E30-0181-05	AC POWER CORD	P	
10	2A		E30-0505-05	AUDIO CORD		
10	2A		E30-1353-05	AUDIO CORD		
△ 11	1C		E30-1305-15	AC POWER CORD (INLET)	UMH	
△ 11	1C		E30-1305-15	AC POWER CORD (INLET)	M UE	
△ 11	1C		E30-1328-15	AC POWER CORD (INLET)	T	
△ 11	1C		E30-1329-05	AC POWER CORD (INLET)	E E	
△ 11	1C		E30-1342-05	AC POWER CORD (INLET)	X	
12	1C	*	G01-0493-04	EXTENSION SPRING		

E: Scandinavia & Europe H: Audio Club K: USA P: Canada K : USA (KX-31B) E : Scandinavia & Europe
S: South Africa T: England U: PX(Far East, Hawaii) P : Canada (KX-31B) (KX-31B)
UE: AAFES(Europe) X: Australia M: Other Areas M : Other area (KX-31B)

PARTS LIST

* New Parts
Parts without Parts No. are not supplied.
Les articles non mentionnés dans le Parts No. ne sont pas fournis.
Teile ohne Parts No. werden nicht geliefert.

△ Indicates safety critical component.

Ref. No.	Address	New Parts	Parts No.	Description	Destination	Remarks
参照番号	位置	新	部品番号	部品名/規格	仕向	備考
-		*	H01-4706-04	ITEM CARTON CASE	KPUMH	
-		*	H01-4706-04	ITEM CARTON CASE	UE XE	
-		*	H01-4707-04	ITEM CARTON CASE	T	
-		*	H01-4777-04	ITEM CARTON CASE	K M	
-		*	H01-4777-04	ITEM CARTON CASE	P E	
-		*	H10-1660-02	POLYSTYRENE FOAMED FIXTURE		
-			H20-1107-04	PROTECTION COVER	KPUHX	
-			H20-1107-04	PROTECTION COVER	TE UE	
-			H20-1107-04	PROTECTION COVER	K P E	
-			H20-1109-04	PROTECTION COVER	M M	
-			H25-0078-04	PROTECTION BAG		
13	2B		J02-0109-05	FOOT(4.2MM)		
14	2B, 3D		J02-0343-05	FOOT(10MM)		
15	1B		J31-0179-04	COLLAR		
△ 16	1D		J42-0083-05	POWER CORD BUSHING	KP K	
△ 16	1D		J42-0083-05	POWER CORD BUSHING	P	
17	2B	*	K27-0901-04	KNØB(EJECT)		
18	3B		K29-0485-14	KNØB(REC LEVEL)		
19	3B	*	K29-1172-04	KNØB ASSY(SELECTØR)	KPUMH	
19	3B	*	K29-1172-04	KNØB ASSY(SELECTØR)	XTE	
19	3B	*	K29-1172-04	KNØB ASSY(SELECTØR)	UE	
19	3B	*	K29-1278-04	KNØB ASSY(SELECTØR)	K M	
19	3B	*	K29-1278-04	KNØB ASSY(SELECTØR)	P E	
20	2B		K29-1176-04	KNØB ASSY(POWER)		
21	2C	*	K29-1201-04	KNØB(PLAY,FF,REW)	KPUMH	
21	2C	*	K29-1201-04	KNØB(PLAY,FF,REW)	XTE	
21	2C	*	K29-1201-04	KNØB(PLAY,FF,REW)	UE	
21	2C	*	K29-1277-04	KNØB(PLAY,FF,REW)	K M	
21	2C	*	K29-1277-04	KNØB(PLAY,FF,REW)	P E	
22	2C	*	K29-1202-04	KNØB(REC)		
23	2C	*	K29-1203-04	KNØB(STØP,PAUSE)		
△ 24	1B	*	L01-3051-05	POWER TRANSFORMER	KP K	
△ 24	1B	*	L01-3051-05	POWER TRANSFORMER	P	
△ 24	1B	*	L01-3054-05	POWER TRANSFORMER	UMHXT	
△ 24	1B	*	L01-3054-05	POWER TRANSFORMER	E M E	
△ 24	1B	*	L01-3054-05	POWER TRANSFORMER	UE	
25	1B		N09-0287-05	SEMUS TAPTITE SCREW		
26	2D		N09-0292-05	SCREW		
27	1A, 1B		N09-0377-05	TAPTITE SCREW	KPUMH	
27	1A, 1B		N09-0377-05	TAPTITE SCREW	XTE	
27	1A, 1B		N09-0377-05	TAPTITE SCREW	UE	
27	1A, 1B		N89-3008-45	TAPTITE SCREW	K M	
27	1A, 1B		N89-3008-45	TAPTITE SCREW	P E	
28	1B		N09-0831-04	TAPTITE SCREW		
29	2C, 2D	*	X28-1500-10	RECORD/PLAYBACK UNIT	KP K	
29	2C, 2D	*	X28-1500-10	RECORD/PLAYBACK UNIT	P	
29	2C, 2D	*	X28-1500-81	RECORD/PLAYBACK UNIT	UMHXT	
29	2C, 2D	*	X28-1500-81	RECORD/PLAYBACK UNIT	E M E	
29	2C, 2D	*	X28-1500-81	RECORD/PLAYBACK UNIT	UE	
RECORD/PLAYBACK (X28-1500-10)						
D7		*	B30-0469-05	LED (POWER)		
D8		*	B30-0470-05	LED (DØLBY)		
D9		*	B30-0469-05	LED (REC)		
D10		*	B30-0470-05	LED (PAUSE)		

E: Scandinavia & Europe H: Audio Club K: USA P: Canada K : USA (KX-31B) E : Scandinavia & Europe
S: South Africa T: England U: PX(Far East, Hawaii) P : Canada (KX-31B) (KX-31B)
UE: AAFES(Europe) X: Australia M: Other Areas M : Other area (KX-31B)

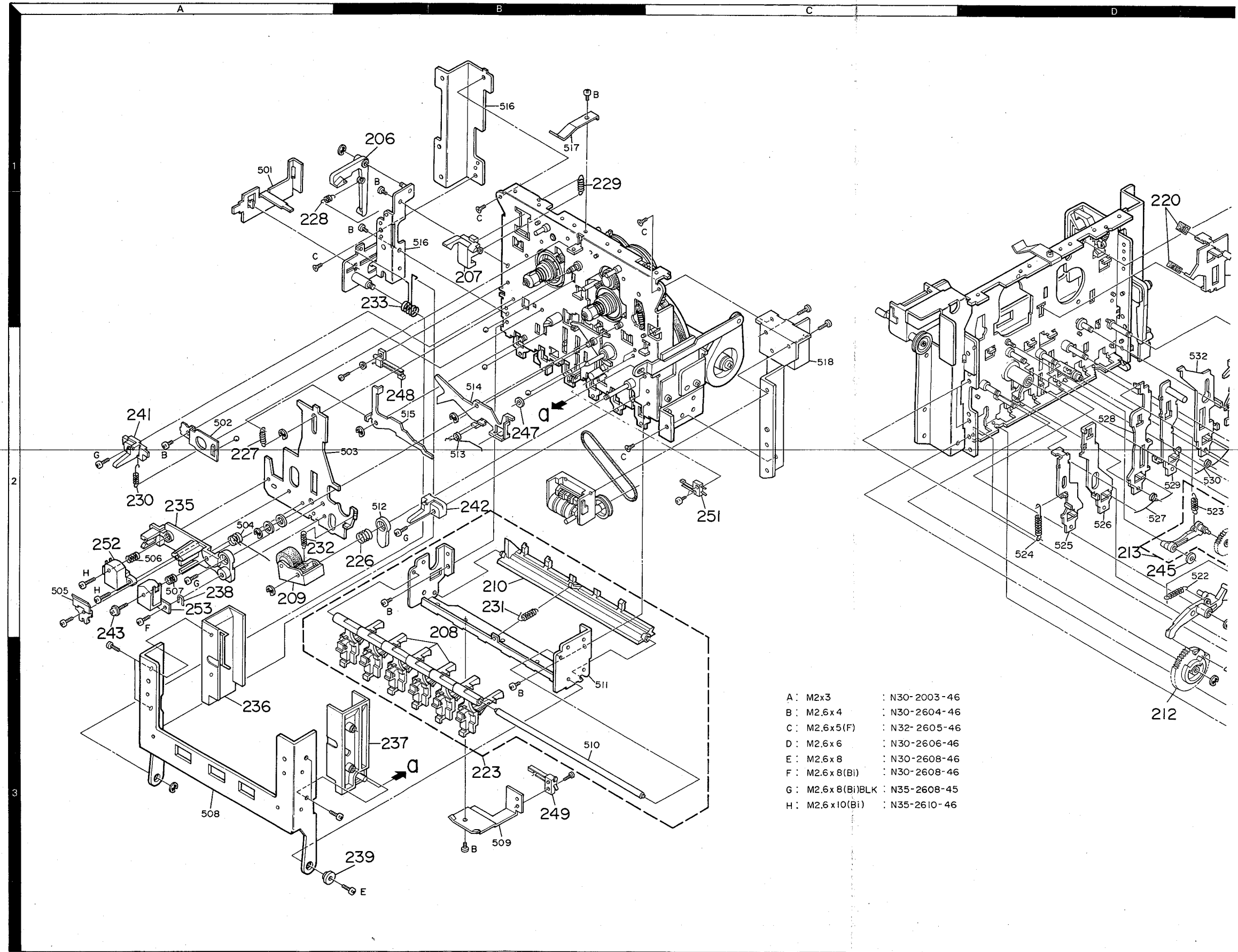

A : M2x3	: N30-2003-46
B : M2.6x4	: N30-2604-46
C : M2.6x5(F)	: N32-2605-46
D : M2.6x6	: N30-2606-46
E : M2.6x8	: N30-2608-46
F : M2.6x8(Bi)	: N30-2608-46
G : M2.6x8(Bi)BLK	: N35-2608-45
H : M2.6x10(Bi)	: N35-2610-46

EXPLODED VIEW

Exploded No. larger than 500 are not supplied.

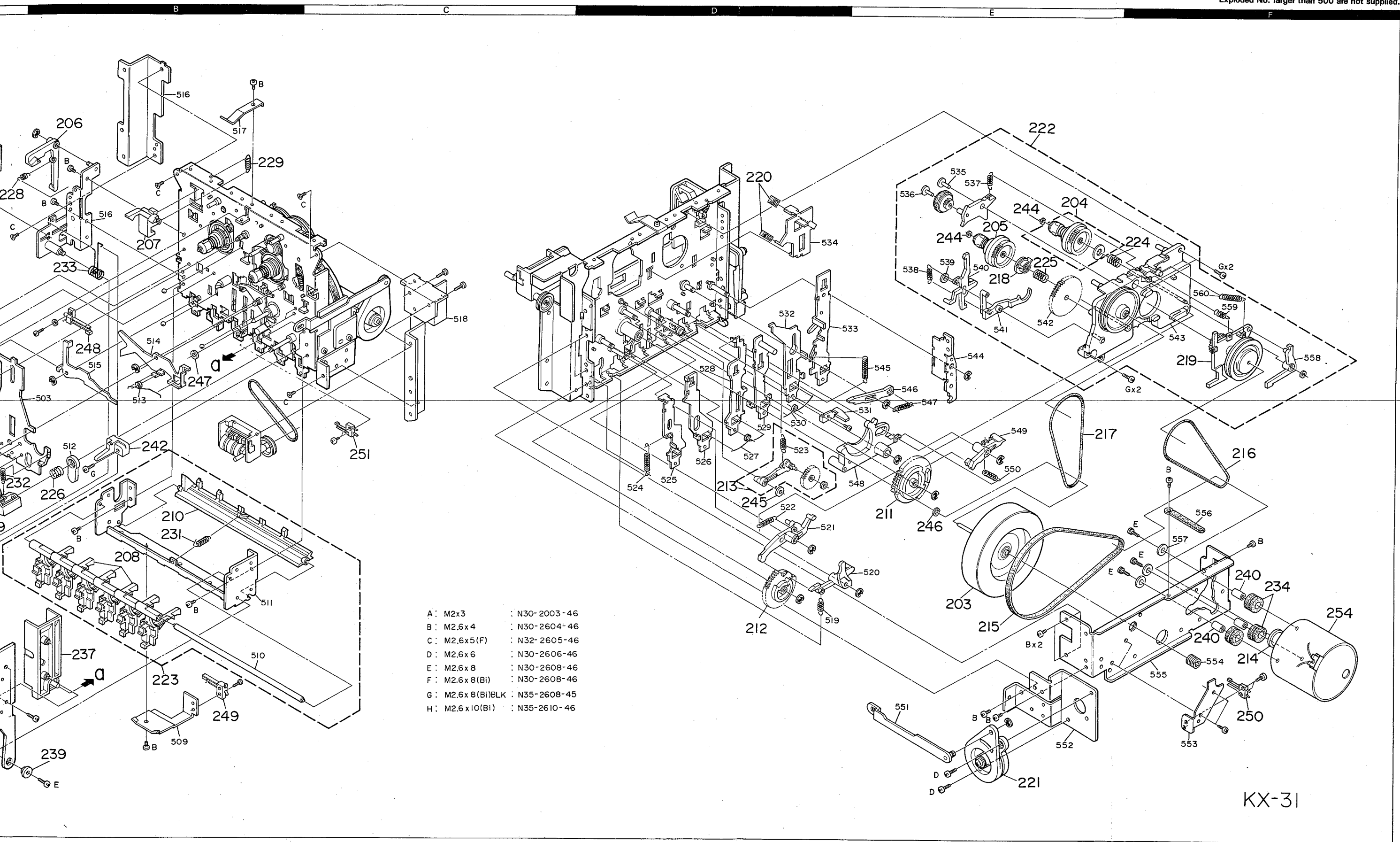

KX-31

PARTS LIST

* New Parts
 Parts without Parts No. are not supplied.
 Les articles non mentionnés dans le Parts No. ne sont pas fournis.
 Teile ohne Parts No. werden nicht geliefert.

Ref. No. 参照番号	Address 位置	New Parts 新	Parts No. 部品番号	Description 部品名 / 規格	Desti- nation 仕 向	Re- marks 備考
MECHANISM ASS'Y (D40-)						
203	3E	*	D01-0042-08	FLYWHEEL		
204	1E	*	D03-0208-08	SUPPLY REEL ASSY		
205	1E	*	D03-0209-08	TAKE UP REEL ASSY		
206	1B	*	D10-0322-08	HOLDER LOCK ARM		
207	1B	*	D10-0323-08	REC SENSOR ARM		
208	3B	*	D10-0324-08	BUTTON LEVER		
209	2A	*	D10-0325-08	PINTCH ROLLER ASSY		
210	2B	*	D12-0090-08	LOCK CAM		
211	2E	*	D13-0081-08	PLAY GEAR		
212	3D	*	D13-0082-08	FR GEAR		
213	2D	*	D13-0083-08	FF GEAR ASSY		
214	3F	*	D15-0195-08	MOTOR PULLEY		
215	3E	*	D16-0073-08	FLAT BELT		
216	2F	*	D16-0074-08	SQUARE BELT		
217	2E	*	D16-0075-08	SQUARE BELT		
218	1E	*	D19-0063-08	AUTO CLUTCH ASSY		
219	2F	*	D19-0194-08	FR PULLEY ARM ASSY		
220	1D	*	D31-0008-08	BRAKE RUBBER		
221	3E	*	D39-0167-08	DUMPER		
222	1E	*	D40-0266-08	REEL BASE ASSY		
223	3B	*	D40-0267-08	OPERATIONAL PARTS ASSY		
224	1E	*	G01-0499-08	BACK TENSION SPRING		
225	1E	*	G01-0500-08	TENSION SPRING		
226	2B	*	G01-1245-08	PAUSE CAM SPRING		
227	2A	*	G01-1246-08	BRAKE SPRING		
228	1A	*	G01-1247-08	PAUSE LEVER SPRING		
229	1B	*	G01-1248-08	REC SENSOR SPRING		
230	2A	*	G01-1249-08	FR LOCK ARM SPRING		
231	2B	*	G01-1250-08	LOCK CAM SPRING		
232	2A	*	G01-1251-08	PINTCH ROLLER SPRING		
233	1B	*	G01-1252-08	CASSETTE HOLDER SPRING		
234	3F	*	G03-0136-08	MOTOR CUSHION		
235	2A	*	J19-0676-08	HEAD BASE		
236	3A	*	J19-0677-08	CASSETTE HOLDER(L)		
237	3B	*	J19-0678-08	CASSETTE HOLDER(R)		
238	2A	*	J30-0171-08	HEAD SPACER		
239	3B	*	J31-0181-08	CASE COLLAR		
240	3F	*	J31-0182-08	MOTOR COLLAR		
241	2A	*	J90-0116-08	CASSETTE GUIDE(L)		
242	2B	*	J90-0117-08	CASSETTE GUIDE(R)		
243	2B	*	N09-1242-08	TP HEAD SCREW		
244	1E	*	N19-0338-08	WASHER		
245	2D	*	N19-0339-08	WASHER		
246	2E	*	N19-0340-08	WASHER		
247	2B	*	N19-0341-08	WASHER		
248	2B	*	S46-1020-08	PLAY SWITCH		
249	3B	*	S46-1021-08	PLAY LEVER SWITCH		
250	3F	*	S46-1021-08	PAUSE SWITCH		
251	2C	*	S46-1023-08	FR SWITCH		
252	2A		T32-0010-05	ERASE HEAD		
253	2A		T34-0018-05	R/P HEAD		

E: Scandinavia & Europe H: Audio Club K: USA P: Canada
 S: South Africa T: England U: PX(Far East, Hawaii)
 UE: AAFES(Europe) X: Australia M: Other Areas

PARTS LIST

* New Parts
 Parts without Parts No. are not supplied.
 Les articles non mentionnés dans le Parts No. ne sont pas fournis.
 Teile ohne Parts No. werden nicht geliefert.

Ref. No. 参照番号	Address 位置	New Parts 新	Parts No. 部品番号	Description 部品名 / 規格	Desti- nation 仕 向	Re- marks 備考
254	3F		T42-0020-05	DC MOTOR		

E: Scandinavia & Europe H: Audio Club K: USA P: Canada
 S: South Africa T: England U: PX(Far East, Hawaii)
 UE: AAFES(Europe) X: Australia M: Other Areas

MECHANISM DESCRIPTION

15. AUTO-STOP Operation (2)

- (1) The auto-gear continues to rotate after the take-up reel has stopped at a tape end. (2)
- (2) The cam on the auto-gear pushes the sensor arm (6) and the sensor arm pushes the projection of the auto-clutch and pushes back the auto-clutch. (7)
- (3) Since the take-up reel has stopped, the auto-clutch does not rotate and the sensor arm stops moving. (8)
- (4) The cam on the rotating auto-gear comes in contact with projection (w) of the auto-arm and pushes up auto-arm (18).
- (5) Projection (x) of the auto-arm engages with the stop slider and the stop slider is pulled by the projection (x) of the auto-arm. The operation then stops.

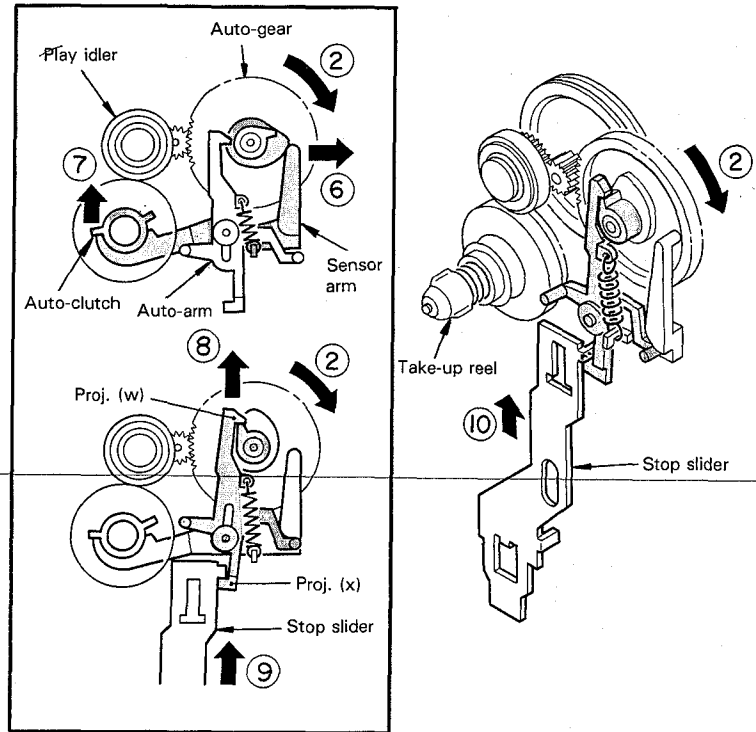

Fig. 15 AUTO-STOP operation (2)

16. AUTO-STOP Operation (3) in the PAUSE mode

- (1) The pause slider is pushed up by pressing the PAUSE button.
- (2) Projection (y) of the pause slider pushes up the auto-lock arm and the auto-lock arm rises. (2)
- (3) The auto-lock arm pushes up the auto-arm. (3)
- (4) The sensor arm repeats a periodic movement due to rotation of the cam on the auto-gear (4), but the auto-arm has stopped being disengaged from the cam on the auto-gear since it is pushed up by the auto-lock arm.
- (5) Even if the take-up reel has stopped, the auto-stop mechanism does not operate.

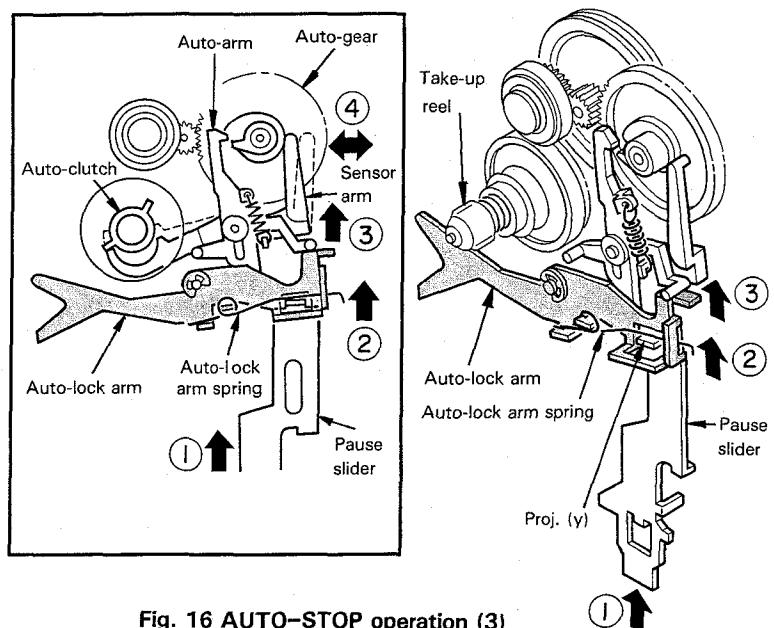

Fig. 16 AUTO-STOP operation (3)

MECHANISM DESCRIPTION

13. RECORD Operation (3)

- (1) If the FF button is pressed during recording, it cannot be fully depressed since the FR lock arm is blocked by the projection of the record slider.

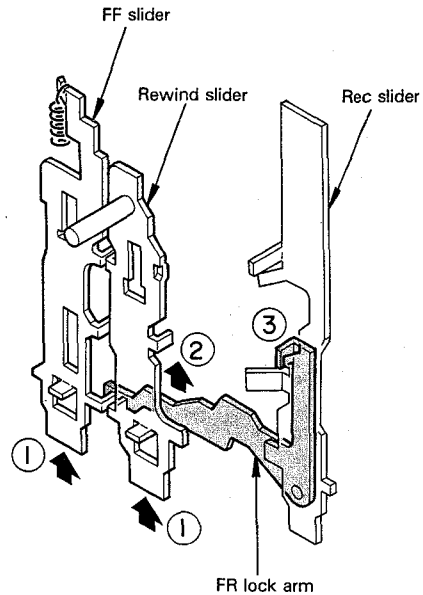

Fig. 13 RECORD operation (3)

14. AUTO-STOP Operation (1)

- (1) During PLAY Operation
The gear on the auto-pulley rotates the play idler gear (①), and the take-up reel is rotated by the play idler. (②, ③)
- (2) The auto-pulley gear is also engaged with the auto-gear, and has been rotating since the motor began to rotate upon power on.
- (3) The auto-clutch also rotates in the direction shown by the arrow ④ due to rotation of the take-up reel. The projection of the auto-clutch pushes the sensor arm and rotate it in the direction shown by the arrow ⑤. The auto-arm is also rotated.
- (4) The cam on the auto-gear pushes the sensor arm due to rotation of auto-gear (⑥), and the sensor arm presses the projection of the auto-clutch and rotate the auto-clutch in the direction shown by the arrow ⑦.
- (5) During PLAY operations, the operations described in (3) and (4) are repeated.

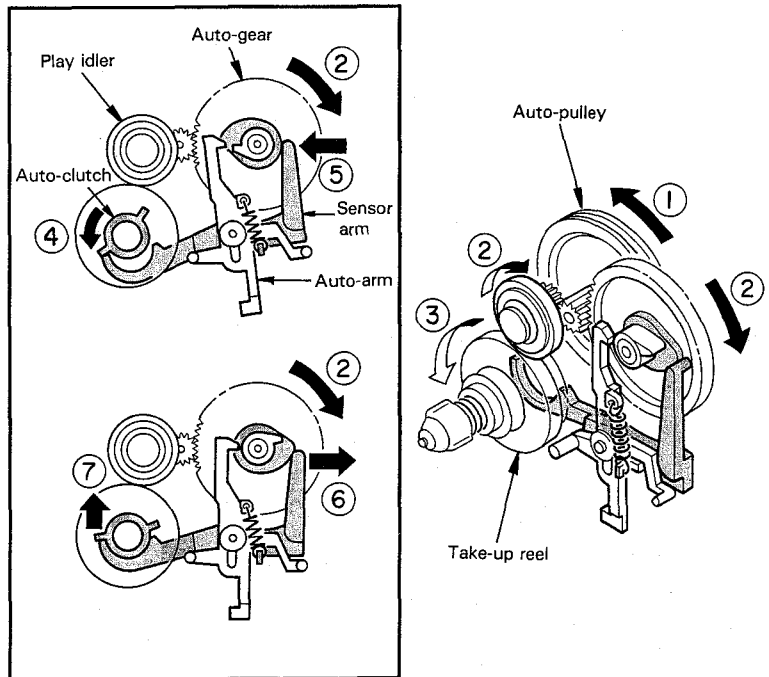

Fig. 14 AUTO-STOP operation (1)

MECHANISM DESCRIPTION

11. RECORD Operation (1)

- (1) The record sensor is pushed up by mounting a cassette with anti-recording tabs. (①)
- (2) Projection (r) of the record sensor moves in the direction shown by the arrow (②).
- (3) The record slider is pushed up by pressing the record button. (③)
- (4) Projection (t) of the record slider pushes up projection (s) of the play slider. (④)
- (5) Once the record slider and the play slider are locked, the mechanism operates in the PLAY operation.
- (6) If the cassette has no anti-record tabs, or if no cassette is mounted, the mechanism does not operate when record button is pressed, since the record slider is blocked by projection (r) of the record sensor and cannot rise.

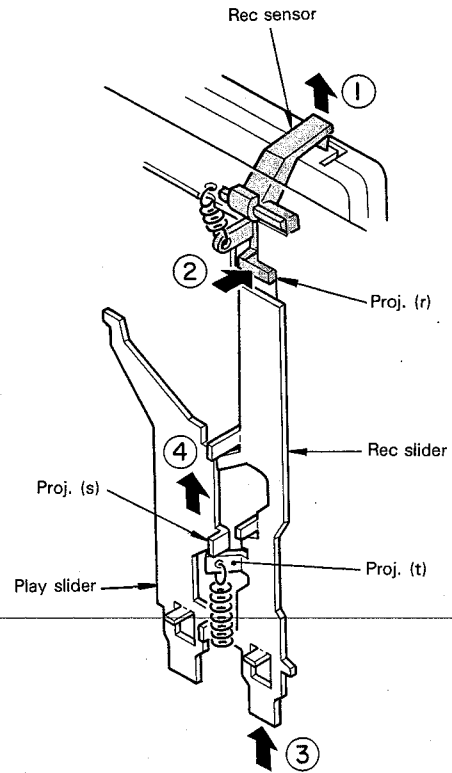

Fig. 11 RECORD operation (1)

12. RECORD Operation (2)

- (1) The record slider is pushed up and projection (u) of the record slider pushes up the record lever. (⑤)
- (2) The record lever comes in contact with projection (v) of the shift arm (A).
- (3) The record lever is pushed in the direction shown by the arrow (⑦) due to rotation of the shift arm (A) (⑥), and rotates the record arm. (⑧)
- (4) The end of the record arm comes in contact with the REC/PLAY switch and operates the switch to set the circuit for recording.

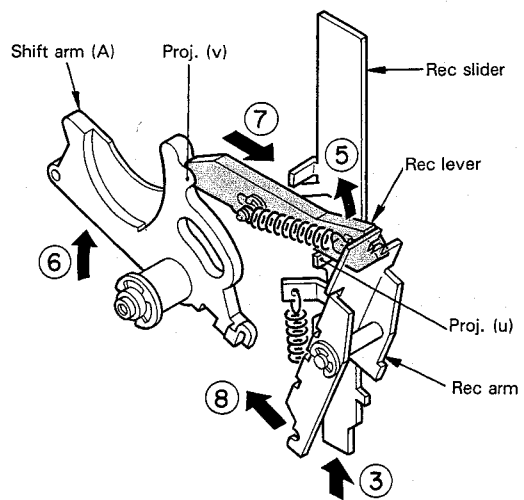

Fig. 12 RECORD operation (2)

MECHANISM DESCRIPTION

- (4) The shift arm (B), pulled by the FR trigger spring, pushes the cam on the FR gear (3) and rotates the FR gear in the direction shown by the arrow (4).
- (5) The flywheel gear and the FR gear engage with each other and the FR gear rotates. (5)
- (6) The shift arm (B) rotates in the direction shown by the arrow (6) due to rotation of the cam on the FR gear.
- (7) Projection (n) on the shift arm (B) comes into contact with projection (o) on the head chassis (7) and pushes the head chassis down, and the REC/PLAY head and moves down a little from the PLAY position. (8)

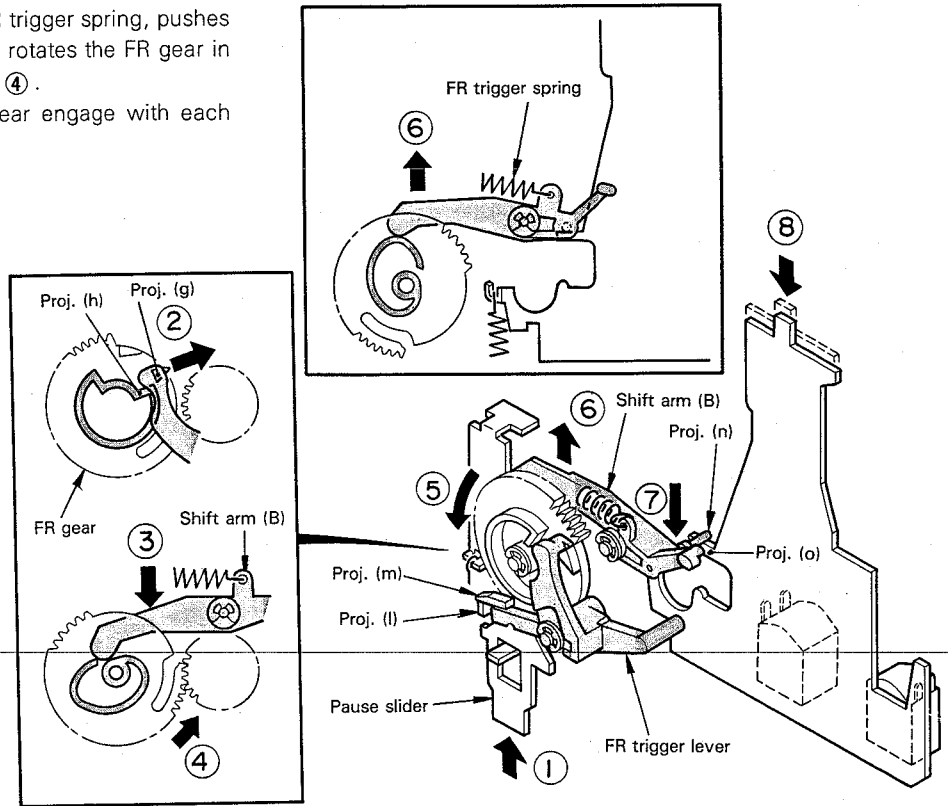

Fig. 9 PAUSE operation (1)

9. PAUSE Operation (2)

- (1) The head base is pushed down (9) and projection (e) on the play arm is moved in the direction shown by the arrow (10).
 - (2) The play arm rotates in the direction shown by the arrow (11) and the play idler disengages from the take-up reel, and the take up reel stops rotating.
 - (3) Projection (p) of the head chassis pushes down the pinch roller arm (12) while the head base is being pushed down.
 - (4) The pinch roller disengages from the capstan and the tape stops. A suitable gap between the pinch roller and the capstan is about 1.2 mm. (13)
- Note: If necessary, adjust the gap by bending projection (O) on the head chassis.

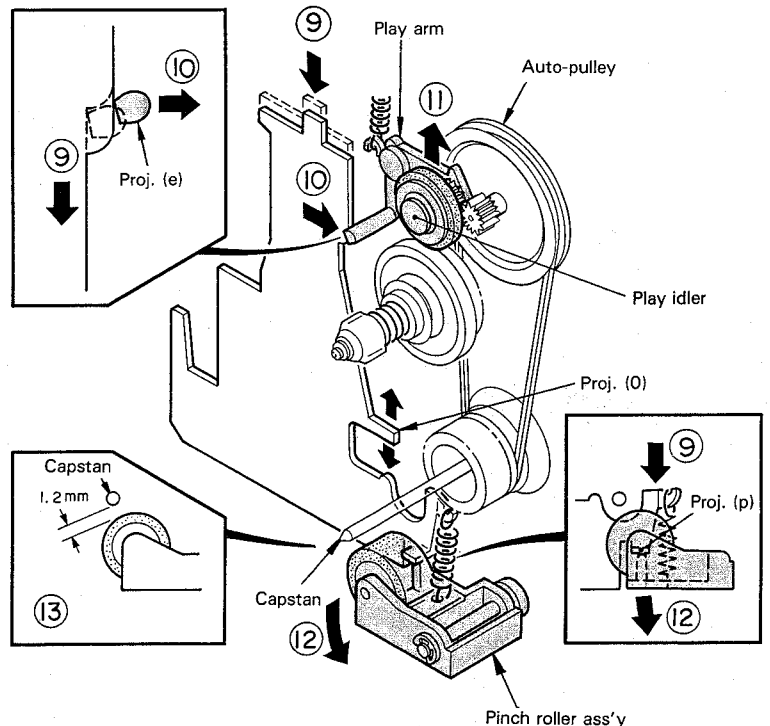

Fig. 10 PAUSE operation (2)

10. CUE and REVIEW Operation

- (1) The CUE and REVIEW operations are entered from the PLAY mode.
- (2) The state of the mechanism is same as in the PAUSE mode except that the take-up reel and supply reel rotate at FF/REWIND speed.

MECHANISM DESCRIPTION

7. REWIND Operation

- (1) The rewind slider is pushed up (⑩) by pressing the REW button (⑪); the brake slider is then pushed up by the rewind slider. (⑬)
- (2) Projection (j) of the rewind slider presses the FR lever and rotate it in the direction shown by the arrow ④ . The FR trigger lever then rotates in the direction shown by the arrow ⑤ . (See the FF operation (1))
- (3) The following operations are the same as those in (3) to (8) of the FF operation (1).
- (4) The rewind slider is pushed up and projection (k) on the rewind slider pushes up the rewind arm and rotates it in the direction shown by the arrow ⑯ .

- (5) The FR pulley arm ass'y is moved in the direction shown by the arrow ⑰ .
- (6) The shift arm (B) is pushed up in the direction shown by the arrow ⑱ due to rotation of the FR gear.
- (7) The FR pulley arm ass'y is pressed down in the direction shown by the arrow ⑲ and the gear on the FR pulley arm ass'y engages with the supply reel gear.
- (8) The FR pulley is driven by the square belt and rotate in the direction shown by the arrow ㉓ and the supply reel rotates in the direction shown by the arrow ㉔ .

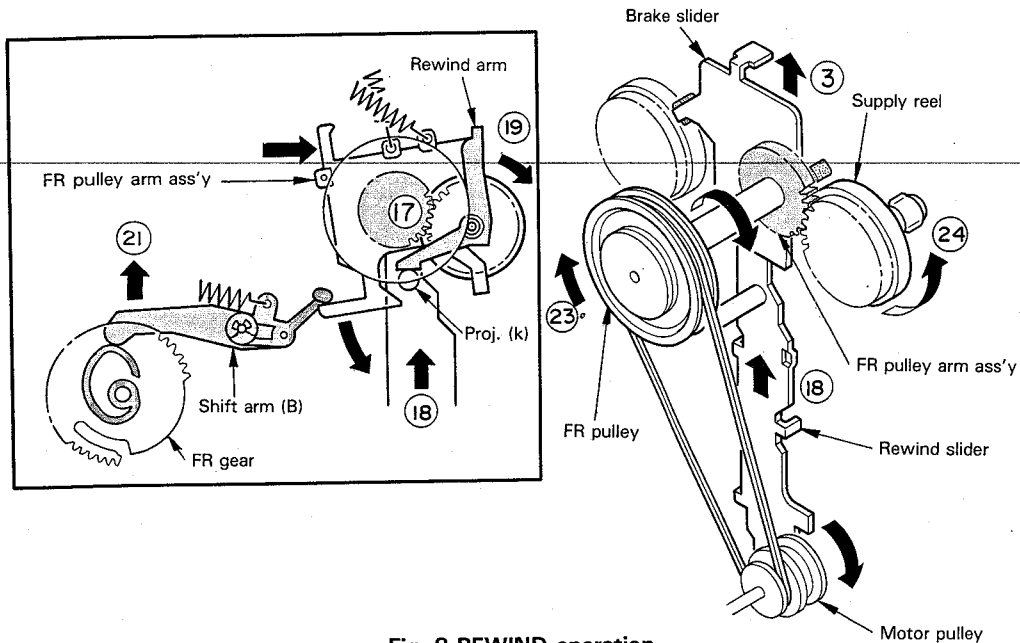

Fig. 8 REWIND operation

8. PAUSE Operation (1)

- (1) Since the PAUSE mode is entered from the PLAY mode, the play slider has been locked, the play trigger lever has been pulled, the brake slider has been detached from the supply reel, and the head chassis has been pushed up. (See PLAY operation)

- (2) The pause slider is pushed up by pressing the pause button; projection (l) on the pause slider pushes up projection (m) on the FR trigger lever. (①)
- (3) Projection (g) on the FR trigger lever disengages from projection (h) on the FR gear.

MECHANISM DESCRIPTION

6. FF Operation (2)

- (1) The FF slider is pushed up (②) and it pulls up the FF gear spring. The FF gear spring pulls up the FF idler arm (⑫) and the FF gear engages with the take-up reel gear.
- (2) The shift arm (B) is pushed up in the direction shown by the arrow ⑬ by the rotation of the FR gear during the above operation. The shift arm (B) rotates the FR pulley

arm ass'y in the direction shown by the arrow ⑭ , and the gear on the FR pulley arm ass'y engages with the FF gear.

- (3) The FR pulley is driven to rotate in the direction shown by the arrow ⑮ by the square belt; the take-up reel then rotates in the direction shown by the arrow ⑯ .

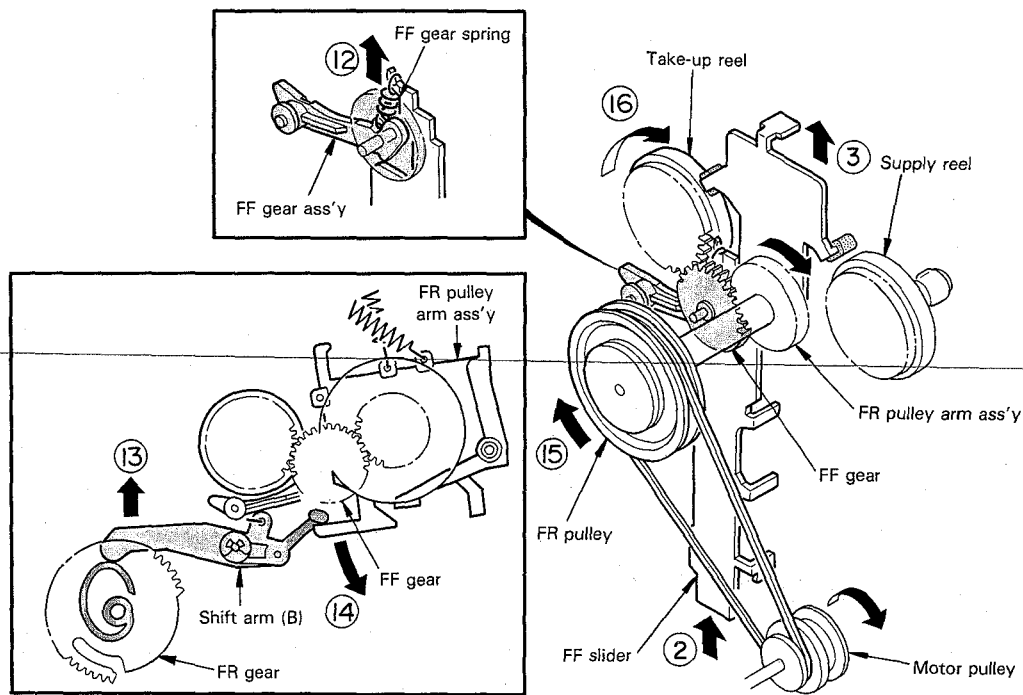

Fig. 7 FF operation (2)

MECHANISM DESCRIPTION

5. FF Operation (1)

- (1) The FF slider is pushed up (2) by pressing the FF button (1) and the brake slider is pushed up by the FF slider (3)
- (2) Projection (f) of the FF slider pushes the FR lever and rotate it in the direction shown by the arrow (4). The FR trigger lever then rotates in the direction shown by the arrow (5), pushed by the FR lever.
- (3) Projection (g) of the FR trigger disengages from projection (h) of the FR gear. (6)
- (4) The shift arm (B) is pulled by the FR trigger spring and

- pushes the cam on the FR gear (7) to rotate the FR gear slightly in the direction shown by the arrow (8).
- (5) The flywheel gear and the FR gear engage with each other and the FR gear is rotated. (9)
- (6) The FR gear stops when the non-toothed portion of the FR gear meets the capstan gear.
- (7) The shift arm (B), pulled by the FR trigger spring, pushes the cam on the FR gear (10) to rotate the FR gear slightly in the direction shown by the arrow (11).
- (8) Projection (i) of the FR gear comes into contact with projection (g) of the FR trigger gear and the FR gear stops rotating.

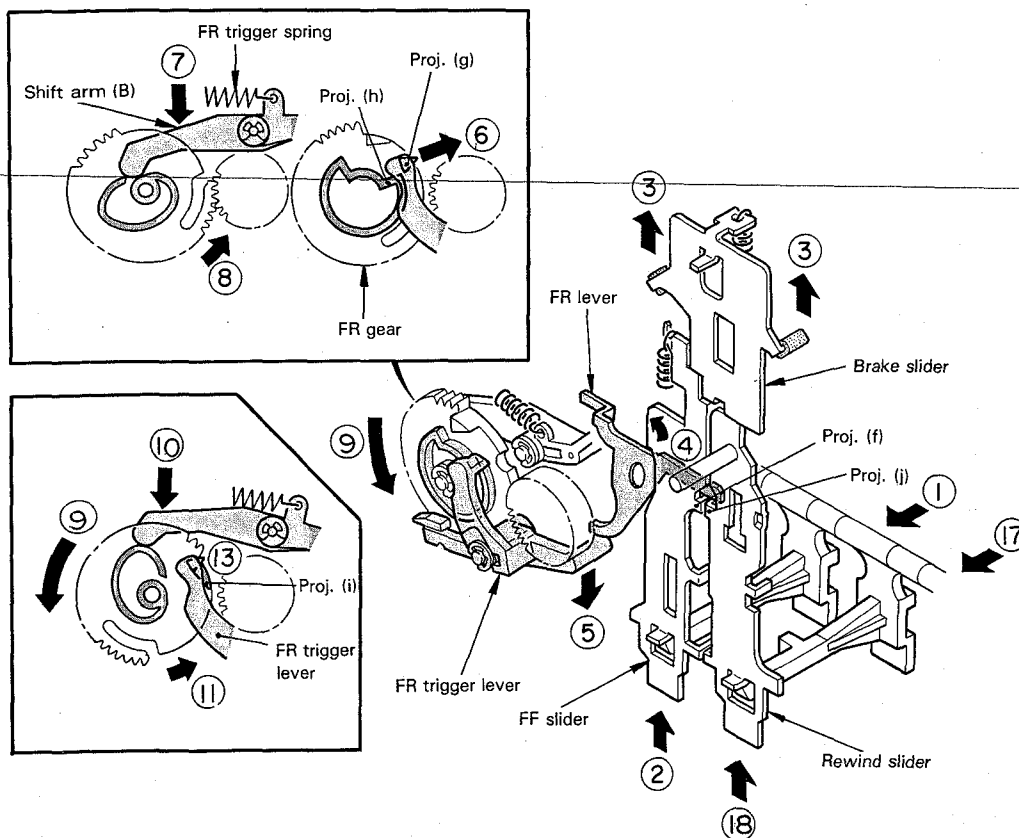

Fig. 6 FF operation (1)

MECHANISM DESCRIPTION

3. PLAY Operation (3)

- (1) The play gear rotates the shift arm (A) in the direction shown by the arrow ⑨ with the cam on it while it is rotating. The head chassis is then pushed up in the direction shown by the arrow ⑩, moving up the REC/PLAY head mounted on it.

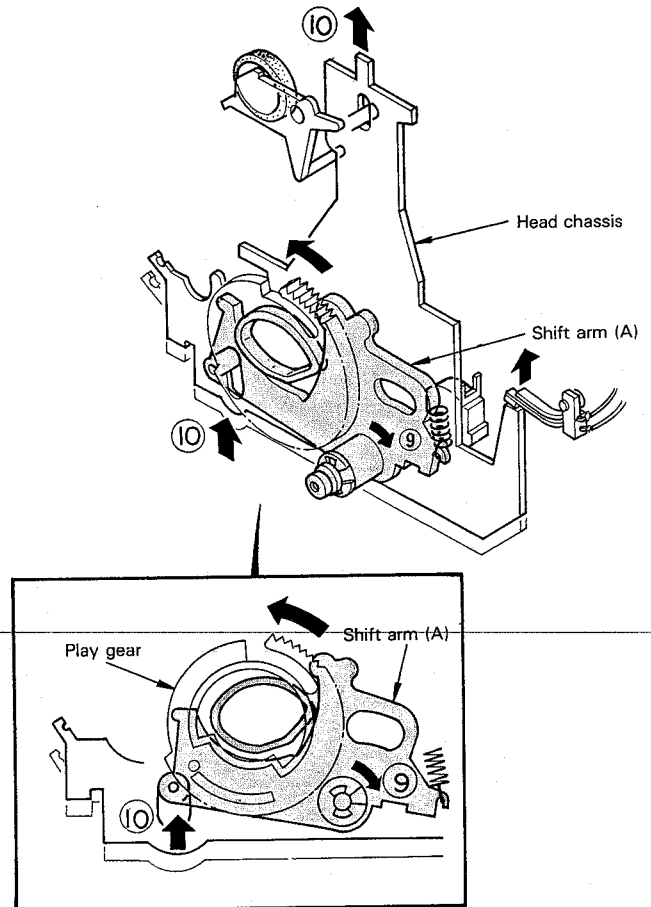

Fig. 4 PLAY operation (3)

4. PLAY Operation (4)

- (1) Since the play arm is pulled up by the play arm spring, projection (e) on the play arm is pressed to the head chassis during the above operation.
- (2) Projection (e) moves in the direction shown by the arrow ⑫ as the head chassis rises (⑪) and the play arm rotates to press the play idler against the take-up reel.
- (3) Since the play idler is always rotating, the take-up reel is driven to rotate by the play idler. (⑬)

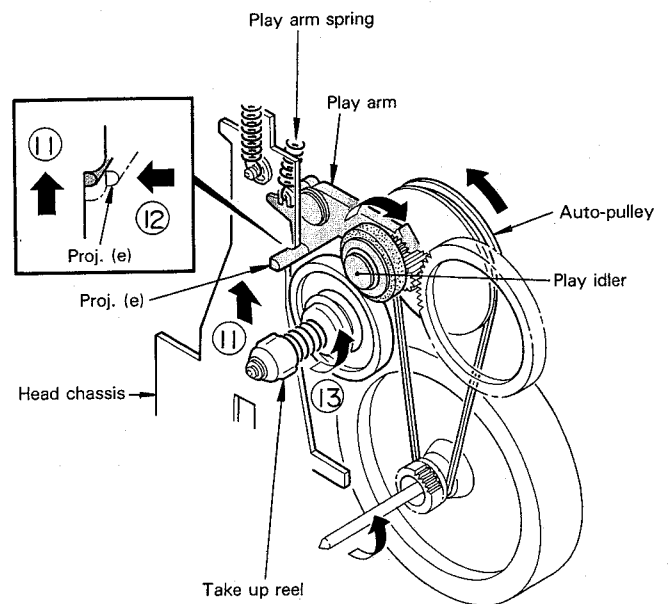

Fig. 5 PLAY operation (4)

MECHANISM DESCRIPTION

1. PLAY Operation (1)

- (1) The flywheel begins to rotate upon the power is turned on. The flywheel gear and the play gear are not in engagement with each other and the play gear is not driven to rotate.
- (2) When the PLAY button is pressed (①), the play slider is pushed up (②) and the brake slider is pushed up by the play slider. (③)
- (3) Projection (a) of the play slider pushes up the play trigger lever in the direction shown by the arrow ④ during the above operation.
- (4) Projection (b) of the play trigger lever disengages from projection (c) of the play gear. (⑤)
- (5) The play gear is rotated in the direction shown by the arrow ⑥, pulled by the play trigger spring.
- (6) The flywheel gear and the play gear engage with each other and the play gear is driven to rotate. (⑦)

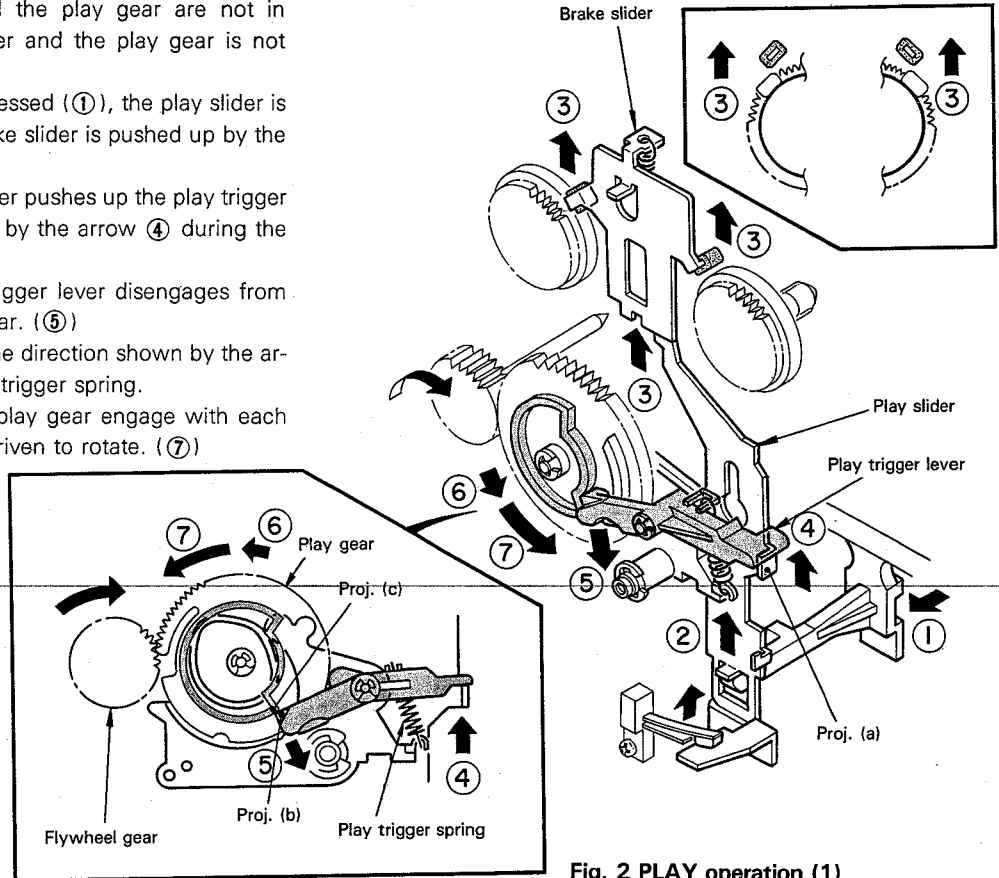

Fig. 2 PLAY operation (1)

2. PLAY Operation (2)

- (1) The play gear rotates driven by the flywheel gear until the non-toothed portion of the play gear meets the flywheel gear.
- (2) The play gear continues to rotate, slightly due to the force of the play trigger spring. (⑧)
- (3) Projection (d) of the play gear comes into contact with projection (b) of the play trigger lever and the play gear stop rotating.

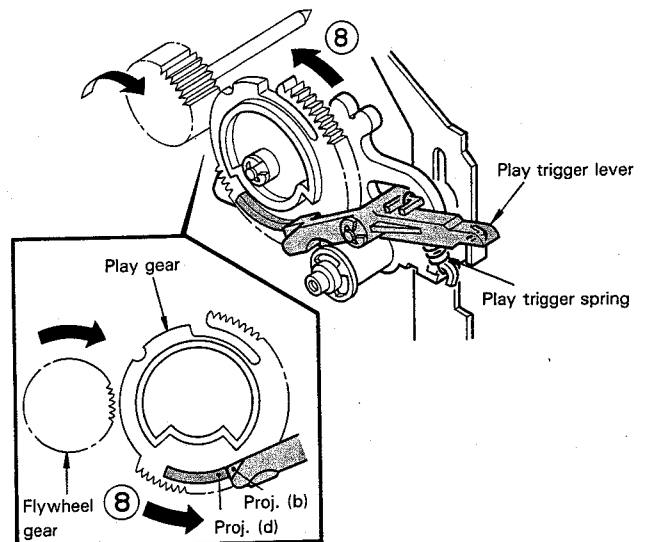
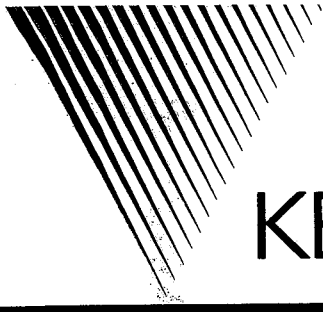

Fig. 3 PLAY operation (2)

x13
430



KENWOOD

KX-100 KX-31

SERVICE MANUAL

SUPPLEMENT

200
306

(Note) This service manual describes the operation of the mechanism of KX-100/31. Please file it with the basic service manual.

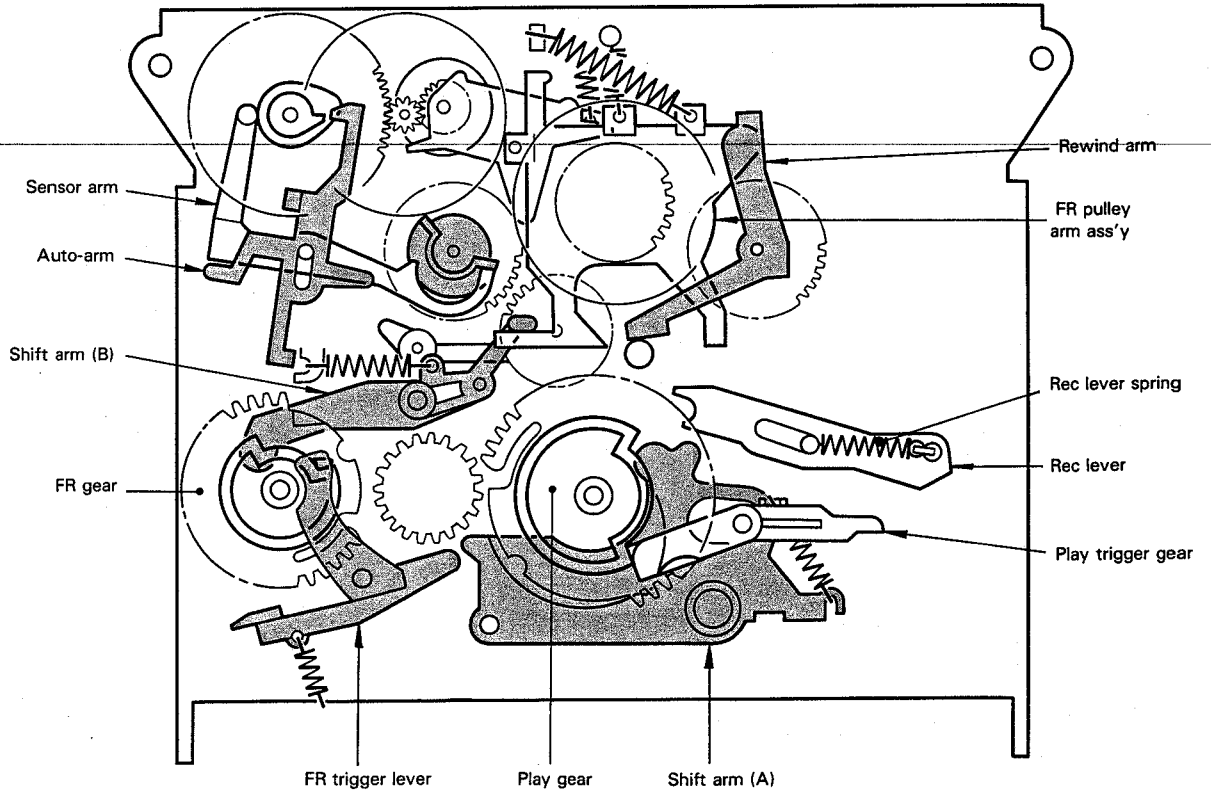
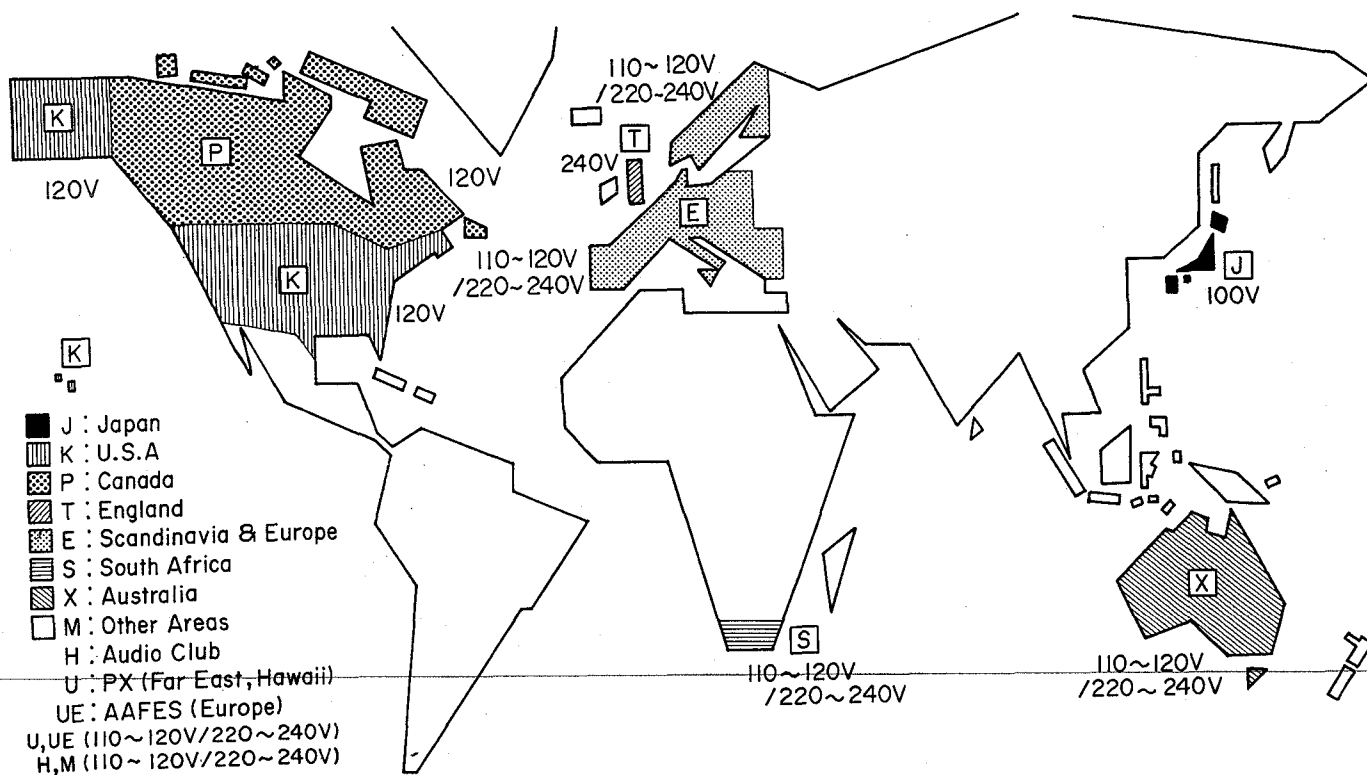

Fig. 1 Mechanism rear view

2776

WORLD MAP & AREA CODE



Note:

Component and circuitry are subject to modification to insure best operation under differing local conditions. This manual is based on the U.S. (K) standard, and provides information on regional circuit modification through use of alternate schematic diagrams, and information on regional component variations through use of parts list.

TRIO-KENWOOD CORPORATION

Shionogi Shibuya Building, 17-5, 2-chome Shibuya, Shibuya-ku, Tokyo 150, Japan

KENWOOD ELECTRONICS

1315 E. Watsoncenter Rd, Carson, California 90745;
 75 Seaview Drive, Secaucus, New Jersey 07094, U.S.A.

TRIO-KENWOOD CANADA INC.,

1070 Jayson Court, Mississauga, Ontario, Canada L4W 2V5

TRIO-KENWOOD ELECTRONICS, N.V.

Leuvensesteenweg 504 B-1930 Zaventem, Belgium

TRIO-KENWOOD ELECTRONICS GmbH

Rudolf-Brass-Str. 20, 6056 Heusenstamm, West Germany

TRIO-KENWOOD FRANCE S.A.

5, Boulevard Ney, 75018 Paris, France

TRIO-KENWOOD (AUSTRALIA) PTY. LTD. (INCORPORATED IN N.S.W.)

4E Woodcock Place, Lane Cove, N.S.W. 2066, Australia

KENWOOD & LEE ELECTRONICS, LTD.

Wang Kee Building, 5th Floor, 34-37, Connaught Road, Central, Hong Kong

PARTS LIST

* New Parts
 Parts without Parts No. are not supplied.
 Les articles non mentionnés dans le Parts No. ne sont pas fournis.
 Teile ohne Parts No. werden nicht geliefert.

△ Indicates safety critical component.

Ref. No. 参照番号	Address 位置	New Parts 新	Parts No. 部品番号	Description 部品名 / 規格	Desti- nation 仕 向	Re- marks 備考
241	2E	*	J90-0116-08	CASSETTE GUIDE(L)		
242	2F	*	J90-0117-08	CASSETTE GUIDE(R)		
243	2F	*	N09-1242-08	TP HEAD SCREW		
244	1I	*	N19-0338-08	WASHER		
245	2H	*	N19-0339-08	WASHER		
246	2I	*	N19-0340-08	WASHER		
247	2F	*	N19-0341-08	WASHER		
248	2F	*	S46-1020-08	PLAY SWITCH		
249	3F	*	S46-1021-08	PLAY LEVER SWITCH		
250	3J	*	S46-1021-08	PAUSE SWITCH		
251	2G	*	S46-1023-08	FR SWITCH		
252	2E		T32-0010-05	ERASE HEAD		
253	2E		T34-0018-05	R/P HEAD		
254	3J		T42-0020-05	DC MOTOR		

E: Scandinavia & Europe H: Audio Club K: USA P: Canada **K** : USA (KX-31B) **E** : Scandinavia & Europe
 S: South Africa T: England U: PX(Far East, Hawaii) **P** : Canada (KX-31B) (KX-31B)
UE : AAFES(Europe) X: Australia M: Other Areas **M** : Other area (KX-31B)