

KENWOOD
HI/FI STEREO COMPONENTS

SERVICE MANUAL

RTV servis Horvat

Kešinci, 31402 Semeljci

031-856-139

031-856-637

098-788-319

rtv-servis-horvat@os.tel.hr

Croatia

KX-400(B)
KX-440(G)

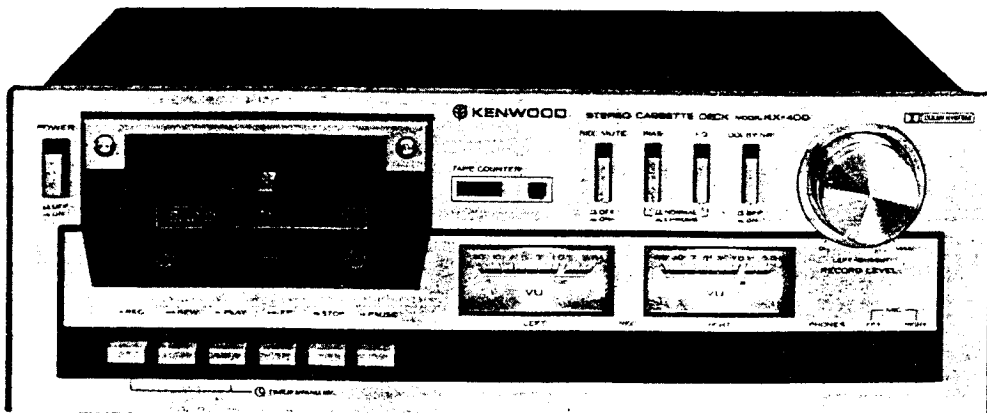

Photo is KX-400

STEREO CASSETTE DECK

CONTENTS

EXTERNAL VIEW.....	3
INTERNAL VIEW.....	4
DISASSEMBLY FOR REPAIR.....	4
BLOCK DIAGRAM.....	6
LEVEL DIAGRAM.....	7
EXPLODED VIEW.....	8
ADJUSTMENT.....	9
MEASUREMENT.....	12
PC BOARD.....	16
SCHEMATIC DIAGRAM.....	17
SPECIFICATIONS.....	17
PARTS LIST.....	18

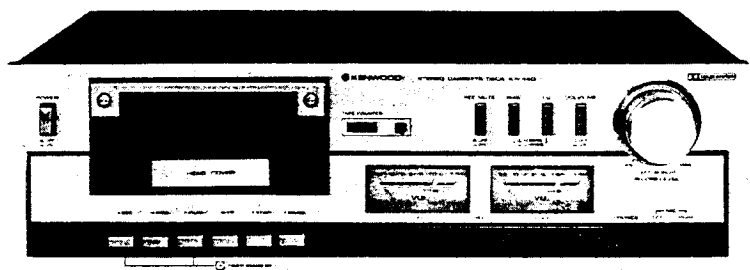

Photo is KX-440

Note:

Component and circuitry are subject to modification to insure best operation under differing local conditions. This manual is based on the U.S. (K) standard, and provides information on regional circuit modification through use of alternate schematic diagrams, and information on regional component variations through use of parts list.

Region.....	Code.....
U.S.A.....	K.....
Canada.....	P.....
PX (Far East).....	U.....

PX (Europe).....	UL.....
Australia.....	X.....
Europe & Scandinavia (KX-440; 440G).....	E.....
Europe & Scandinavia (KX-400).....	W.....
England.....	T.....
South Africa.....	S.....
Other Areas.....	M.....
Audio Club.....	H.....

There is no plan for producing unit of H type.

EXTERNAL VIEW

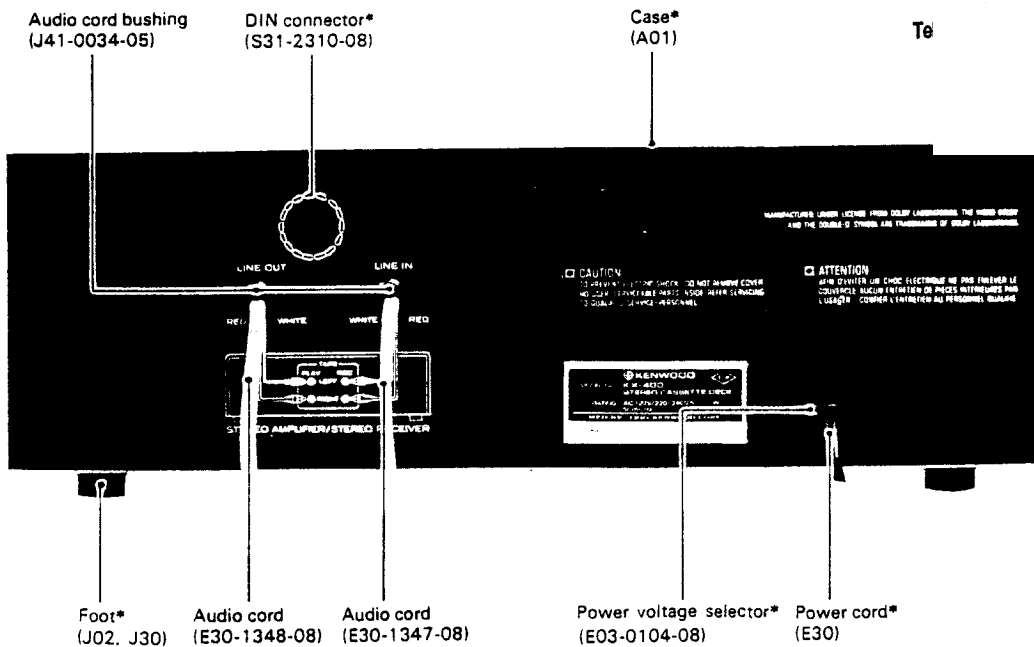
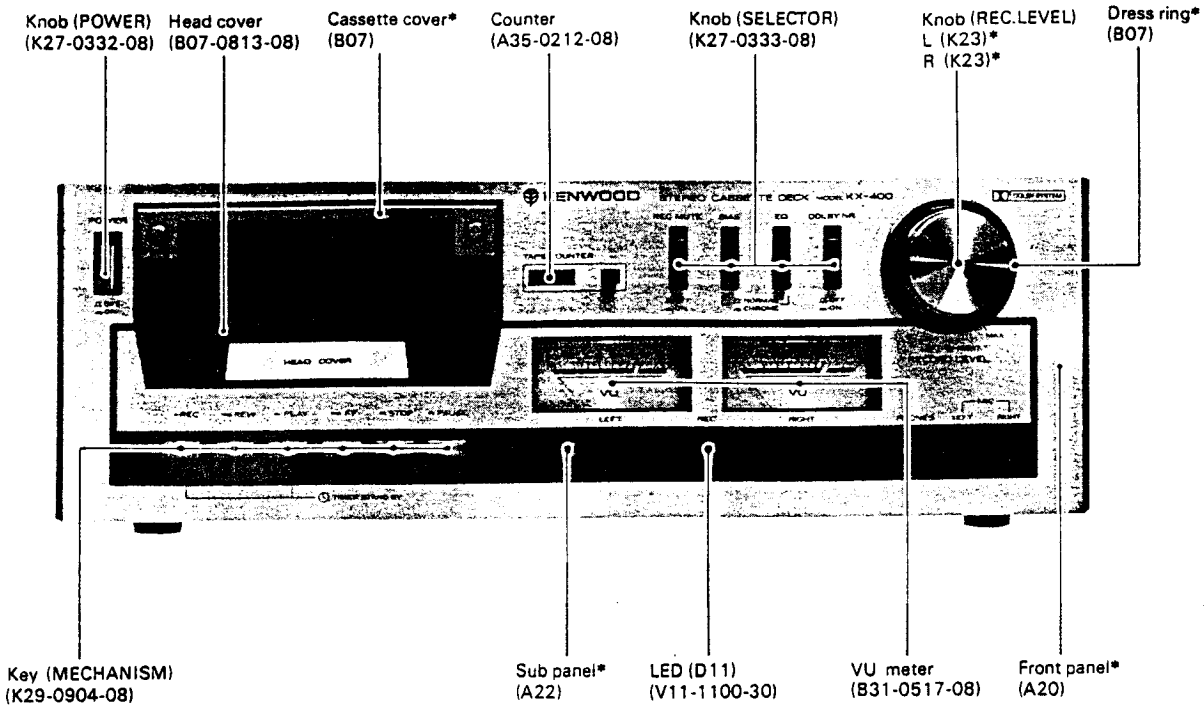
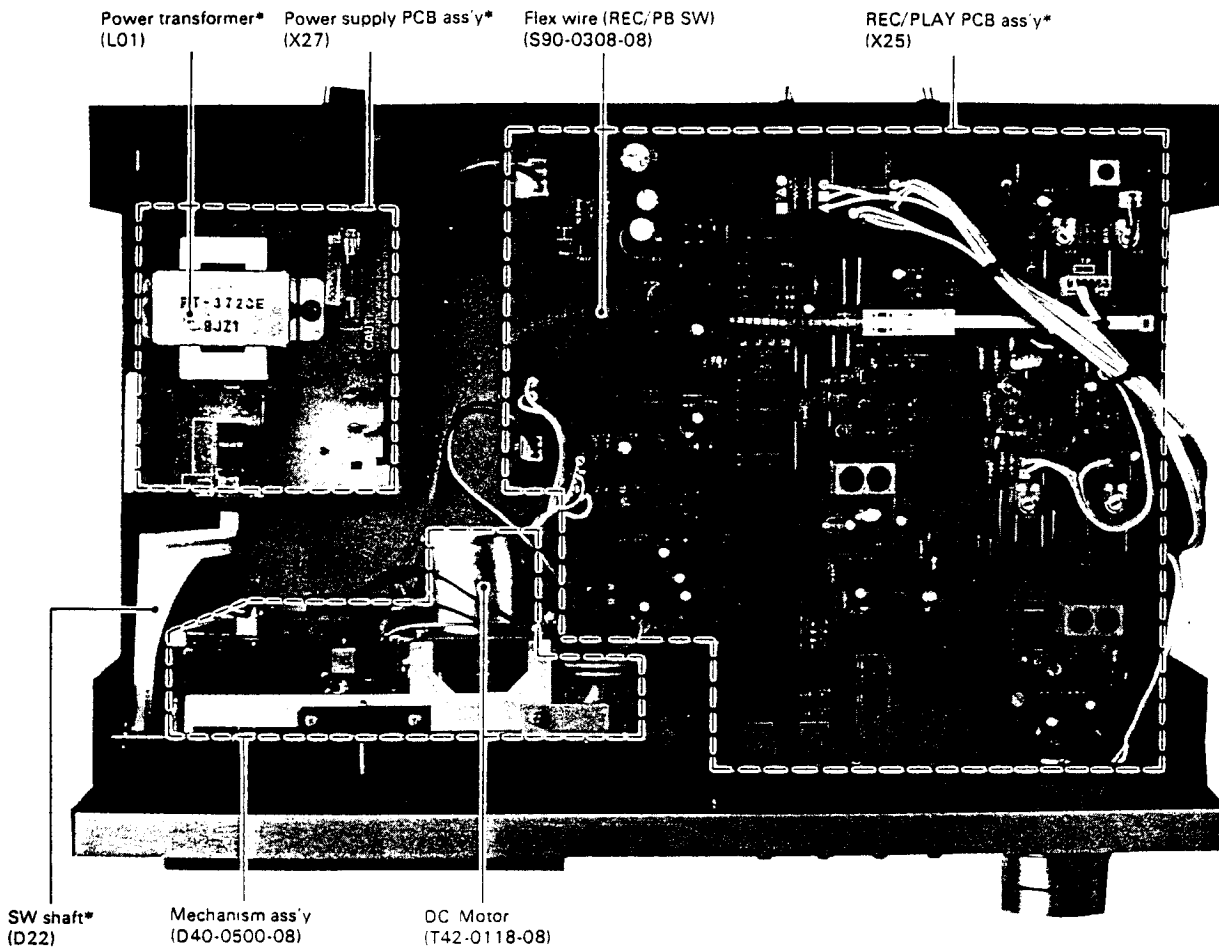

Photo is KX-400
* Refer to parts list

INTERNAL VIEW / DISASSEMBLY FOR REPAIR



DISASSEMBLY FOR REPAIR

* Refer to parts list

Knob (Mechanism) Removal

- 1 Raise the lever claw with a ⊖ screwdriver.
- 2 Pull the knob out

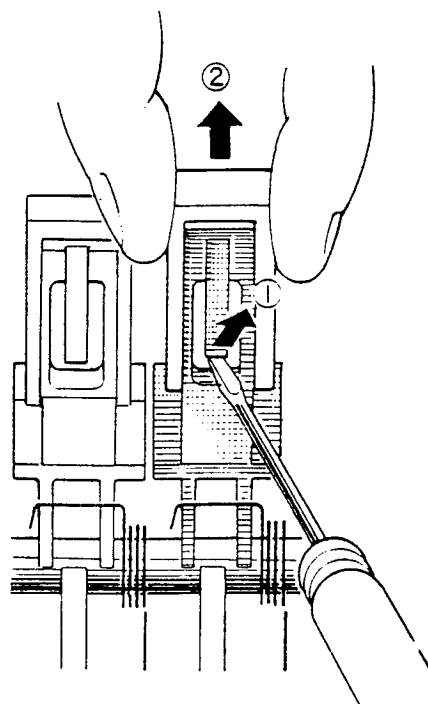

Fig.1 Remove the knobs(mechanism)

DISASSEMBLY FOR REPAIR

Panel Removal

- 1 Remove the knob (REC LEVEL).
- 2 Remove the three screws at the bottom.
- 3 Press the three knobs (POWER, EQ and BIAS). (Each knob locks in position.)
- 4 Press the two knobs (REC MUTE and TAPE COUNTER) at a time.
- 5 Raise the front panel as shown in the figure.

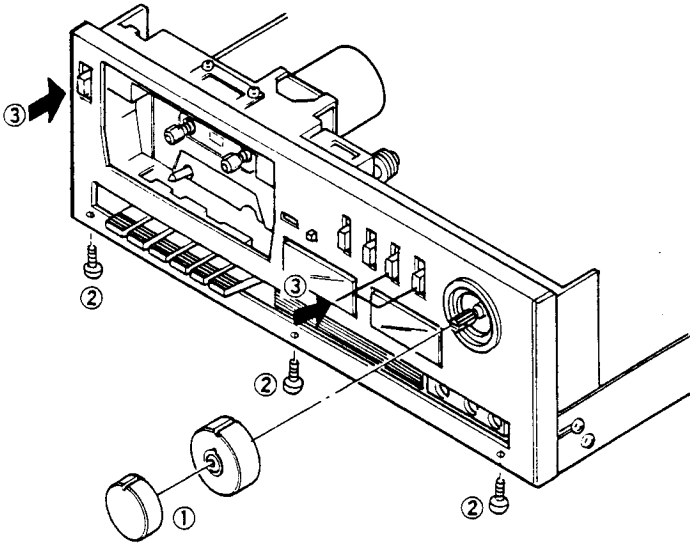

Fig.2 Remove the front panel (1).

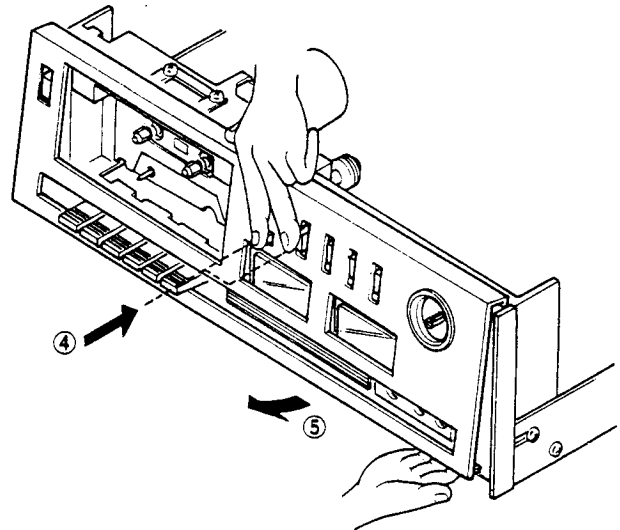

Fig.3 Remove the front panel (2).

Mechanism assembly Removal

- 1 Remove the front panel and the four screws from the sub panel.
- 2 Remove the screw from the bottom cover.
- 3 Disengage the counter belt.
- 4 Remove the mechanism assy as shown in the figure.

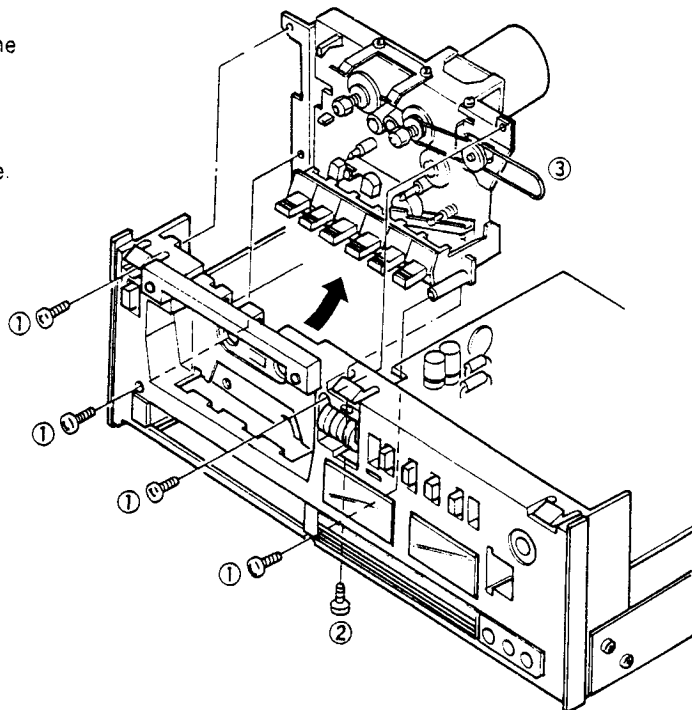
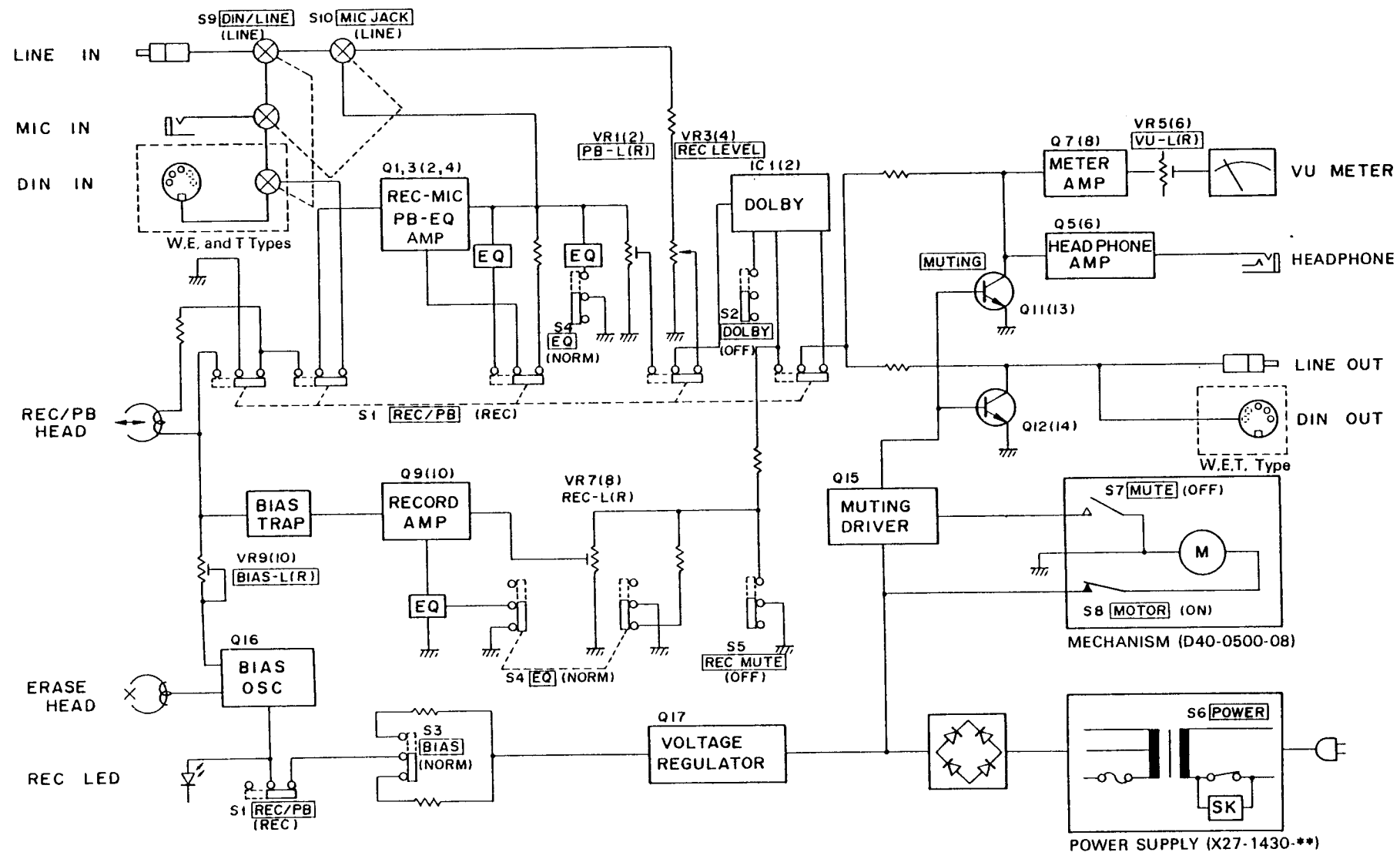

Fig.4 Remove the mechanism assembly.



BLOCK DIAGRAM

LEVEL DIAGRAM

RECORD:

(1 kHz 0 dBs = 0.775 V)

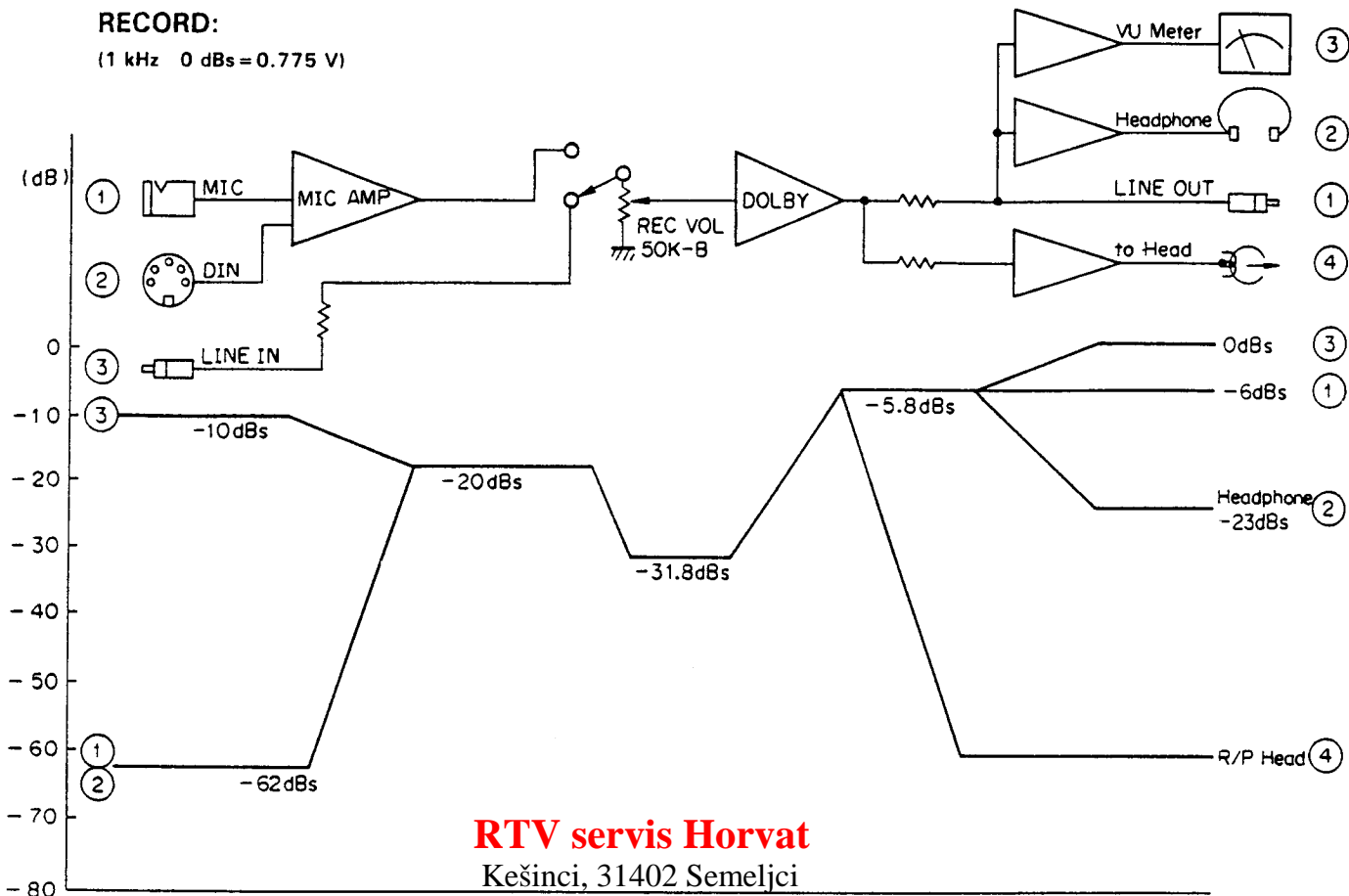

RTV servis Horvat

Kešinci, 31402 Semeljci

031-856-139

031-856-637

098-788-319

rtv-servis-horvat@os.tel.hr

Croatia

PLAYBACK:

(Test tape MTT-216 315 Hz 0 dB)

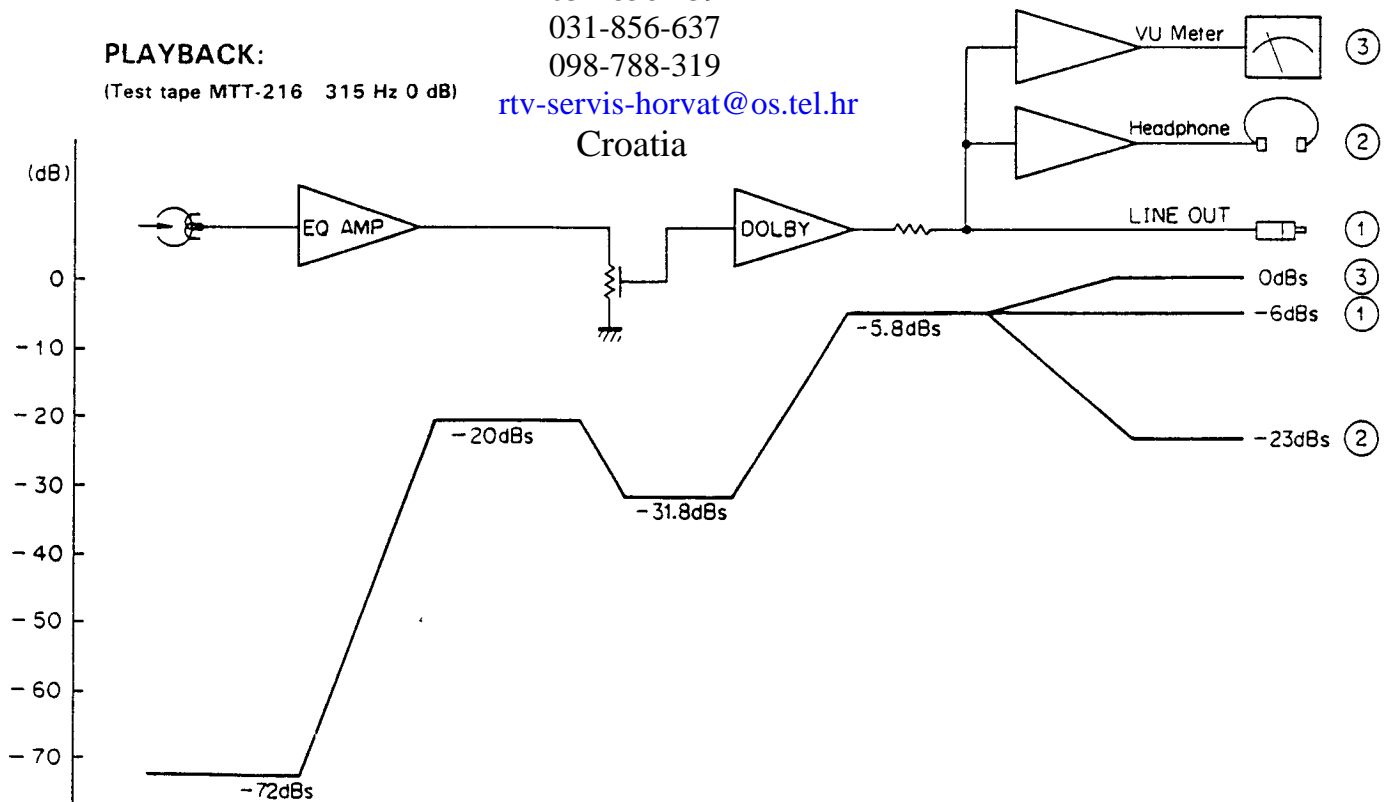

ADJUSTMENT

1. Test Instrument

- AC voltmeter (High input impedance)
- Audio frequency generator:
 - AG
- Oscilloscope
- Frequency counter
- Weighting filter
(ASA A characteristic with NAB curve)
- Band pass filter
(Center frequency: 100 Hz, 1 kHz.
Attenuation: 18 dB/oct. or more)
- Cassette type torque gauge (TW-2111; T99-0208-00)
- Spring balance
- Cleaning tape (T93-0014-05)

2. Test Tape

- a) Test tape for recording system adjustment
NORMAL:
MAXELL UD-XLI (T93-0013-15)
CHROME (for measurement):
TDK AC-511 (T93-0010-05) or SAC-60
- b) Test tape for playback measurement
TEAC MTT-111 (Tape speed, azimuth)(T93-0215-00)
TEAC MTT216R(Frequency characteristic)(T93-0017-00)
TEAC MTT-216 (Frequency characteristic)(T93-0016-00)

3. Meaning of Technical Word

- a) 0 dBs=0.775V
- b) **Normal recording level:** A level to obtain residual magnetic flux of 160 pWb/mm on the standard recording tape, which is 4 dB below the level 315 Hz, 0 dB (250 pWb/mm) of the test tape (MTT-216R).
- c) **Normal input level:** The standard input level necessary for obtaining the normal recording level. The levels at respective input jacks are as specified below. However 80kΩ resistor should be inserted in the input of the DIN connector in series.

MIC INPUT..... -62 dBs (0 VU)
 LINE INPUT..... -10 dBs (0 VU)
 DIN INPUT..... -24 dBs (0 VU)

- d) **Normal recording condition:** The state obtained by applying the 1 kHz signal to the LINE input jack at the normal input level (-10 dBs) and by adjusting the LINE volume control so that recording can be carried out at the normal recording level.

- e) **Normal output level:** The standard signal level obtained at the LINE output jack when the level reference signal is reproduced from the test tape 315 Hz.

MTT-216R 315 Hz (250 pWb/mm)
 Output level: -2 dBs
 MTT-216 315 Hz (160 pWb/mm)
 Output level: -6 dBs

e) Standard playback

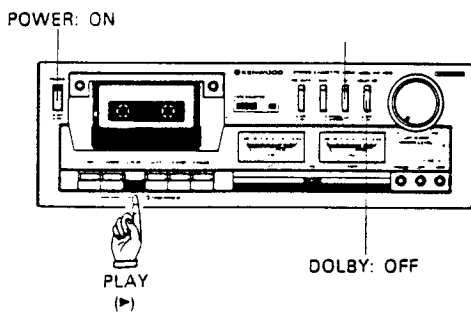

- POWER → ON
- PLAY (▶) BUTTON → Depress
- EQUALIZER → NORMAL
- DOLBY N.R. → OFF

f) Standard recording

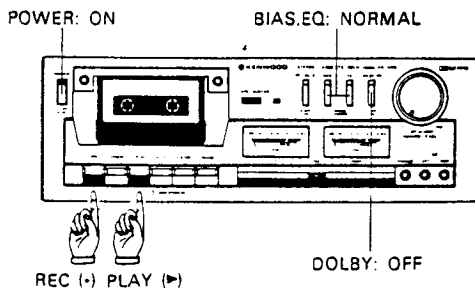

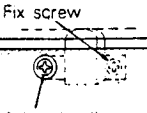

- POWER → ON
- REC (+), PLAY (▶) BUTTON → Depress
- BIAS, EQ → NORMAL
- DOLBY N.R. → OFF

ADJUSTMENT

Step	Item	Input setup	Output setup	Cassette deck setting	Parts to be adjusted		Adjustment
					L	R	
I. Adjusting REC/PLAY head							
1.	Demagnetization and cleaning	—	—	Power: OFF	REC/PLAY HEAD erase head, capstan, pinch roller		Demagnetize the REC/PLAY head with a head demagnetizer or a cassette type demagnetizer. Clean the REC/PLAY head, erase head, capstan and pinch roller using an applicator soaked with alcohol.
2.	Fine adjustment of head azimuth		Ⓐ	Ⓑ MTT-216R: 10kHz, -20dB PLAY: ON DOLBY: OFF BIAS.EQ: NORMAL	 Fix screw Azimuth adj. screw		Adjust screw so that the maximum output is obtained.
Check azimuth of the head again, then lock the screws with adhesive.							
II. Printed circuit board adjustment							
1.	Tape speed	—	Ⓒ	Ⓑ MTT-111 PLAY: ON	PC trimming potentiometer in the DC motor.		Adjust the PC trimming potentiometer so that the reproduced frequency becomes 3000 Hz.
2.	Playback	—	Ⓐ	Ⓑ MTT-216 315 Hz, 0 dB PLAY: ON DOLBY: OFF BIAS.EQ: NORMAL	VR1	VR2	Adjust VR1 (VR2) so that the output of -6 dBs is obtained.
					X25-1570		
3.	Bias oscillator		Ⓓ	Ⓑ Cassette tape REC: ON BIAS.EQ: NORMAL	L7 X25-1570		Adjust frequency to 85 kHz.
4.	Bias current	Ⓔ 1 kHz -30 dBs 10 kHz -30 dBs	Ⓐ	Ⓑ UD-XL1 REC: ON PLAY: ON DOLBY: OFF INPUT: LINE BIAS.EQ: NORMAL RECORD LEVEL: Record 1 kHz and 10 kHz consecutively. CENTER	VR9	VR10	Adjust VR9 (VR10) so that the playback output level of 10 kHz equal to that of 1 kHz.
					X25-1570		
5.	Record current	Ⓔ 1 kHz -10 dBz	ditto	Ⓑ UD-XL1 REC: ON PLAY: ON DOLBY: OFF INPUT: LINE BIAS.EQ: NORMAL Adjust the RECORD LEVEL so that the monitor output becomes -6 dBs and perform recording then playback.	VR7	VR8	Adjust VR7 (VR8) so that the playback output becomes -6 dBs. Note: Adjusting method (Ⓔ) If an output of -6 dBs cannot be obtained, connect an AC voltmeter to the junction between C61 and R77 (C62 and R78). For example, when the playback output of -3.5 dBs (this level is higher than 2.5 dBs from -6 dBs) is obtained, read the reading of the AC voltmeter with this connection during recording. Then, adjust VR7 (VR8) so that the reading of the AC voltmeter reduces by 2.5 dBs. Now, the playback output is set to -6 dBs.
					X25-1570		
6.	VU meter	Ⓔ 1 kHz, -10 dBs	ditto	PAUSE: ON with other setting the same as in Step 5.	VR5	VR6	Adjust to 0 VU.
					X25-1570		

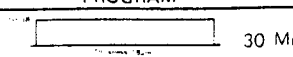
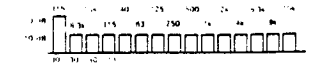
TEST TAPE SPECIFICATION

MODEL	TITLE	TIME CONSTANT	DESCRIPTION		APPLICATION
			FREQ/LEVEL	PROGRAM	
MTT-111	FLUTTER	—	3 kHz -10 dB	 30 Min.	Tape Speed Test Wow and Flutter Test
MTT-216R* (MTT-116R)	FREQUENCY	1590 μs and 120 μs	40 Hz ~ 18 kHz 0 dB / -10 dB 0 dB DIN REFERENCE LEVEL		Frequency Response Test
MTT-216 (MTT-116U)	FREQUENCY	3180 μs and 120 μs	315 Hz ~ 14 kHz 0 dB / -20 dB 0 dB DIN REFERENCE LEVEL -4 dB		Frequency Response Test

Output level of standard recorded level of 250 pWb/mm is 4 dB higher than that of 160 pWb/mm
* Time constants of MTT-216R are 3180 μs and 120 μs.

ADJUSTMENT

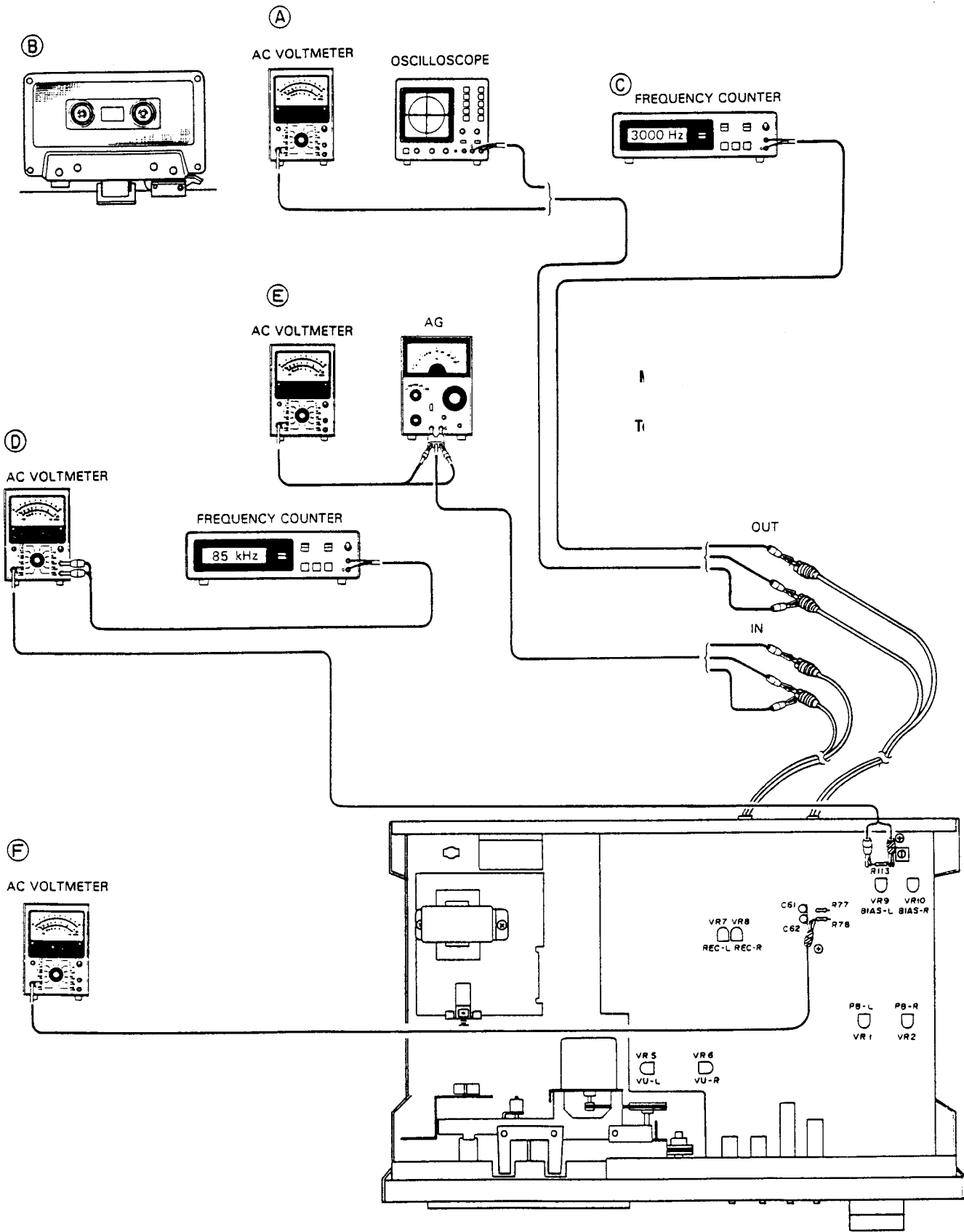

MEASUREMENT (MECHANISM)

Adjustment items	Tape used	Test instruments	Input signal	Conditions and methods	Standard and remarks												
1. Torque				<table border="1"> <tr> <td>REC</td> <td>PLAY</td> <td>BIAS</td> <td>EQ</td> <td>DOLBY</td> <td>SELECTOR</td> </tr> <tr> <td>OFF</td> <td></td> <td>NORMAL</td> <td>NORMAL</td> <td>OFF</td> <td>LINE</td> </tr> </table>	REC	PLAY	BIAS	EQ	DOLBY	SELECTOR	OFF		NORMAL	NORMAL	OFF	LINE	
	REC	PLAY	BIAS	EQ	DOLBY	SELECTOR											
	OFF		NORMAL	NORMAL	OFF	LINE											
	PLAY	SRK-CT-100M TW-2111	—	—	With a tape loaded, press the PLAY button and measure the dynamic torque.	30 ~ 65 g.cm											
FF & REW	SRK-CT-160L TW-2231	—	—	Release the PLAY button and load the specified tape. Press the FF button. When the tape is fully wound, measure the static torque. Next, press the REW button. When the tape is fully rewound, measure the static torque. Repeat the above procedures 3 or 4 times and obtain averages of FF and REW torques.	FF and REW torque 60 ~ 160 g.cm												
Back Tension	SRK-CT-100M TW-2111	—	—	With the FF and REW buttons released, load the specified tape. Press the PLAY button at the beginning of tape and measure the dynamic torque.	1~5 g.cm (supply reel)												
2. Auto Stop Operating Time	SRK-CT-160L (Other tapes may be used) TW-2111	• Stop watch	—	Measure the time required to release the tape button (FF, PLAY, REW) after the tape reaches the end.	Within 7 sec.												
3. Timer Start	SRK-CT-160L (Other tapes may be used)	• Stop watch	—	Press the PLAY (and RECORD) buttons and set the POWER SW to OFF. Turn on the POWER SW a few seconds later and measure the time required to release the PAUSE button.	Within 3 sec.												
4. Tape Speed and Wow/flutter	MTT-111 JIS	• AC voltmeter • Counter • Wow/flutter meter	—	With the specified tape loaded, press the PLAY button and measure the tape speed and wow/flutter. For wow/flutter, measure both the RMS and WRMS values at the peak (JIS) on the wow/flutter meter. This measurement should be made at the beginning, middle and end of the tape.	TAPE SPEED 3kHz±2.0% W&F (JIS) WRMS: 0.12% max.												
	XL-1 (T93-0013-15) DIN	MK-669 • AC voltmeter	3.15 (kHz) Use a built in oscillator	RECORD LEVEL..... MAX Under the above conditions, record and play a 3.15 kHz signal and measure wow/flutter through a DIN weighting circuit. This measurement should be made at the beginning, middle and end of the tape.	W&F (DIN) • 0.2% max.												
6. FF and REW TIME	C-60	• Stop watch	—	Measure the winding time in FF and REW modes.	Within 95 sec. each.												
7. Pinch Roller Pressure	—	• Spring balance	—	Use a compression spring balance to push the pinch roller 1~2 mm, from the capstan thus stopping the pinch roller. Then, allow the pinch roller to contact the capstan just enough to start the pinch roller turning slightly, and read the measurement.	350±50g												

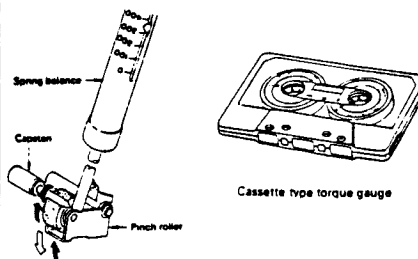

MEASUREMENT (AMP)

Adjustment items	Tape used	Test instrument	Input signal	Conditions and methods	Standard and remarks												
1. Playback Level	MTT-116U (MTT-216)	• AC volt meter • Oscilloscope	—	<table border="1" style="width: 100%; border-collapse: collapse; margin-bottom: 5px;"> <tr> <td>REC</td><td>PLAY</td><td>BIAS</td><td>EQ</td><td>DOLBY</td><td>SELECTOR</td> </tr> <tr> <td>OFF</td><td>ON</td><td>NORMAL</td><td>NORMAL</td><td>OFF</td><td>LINE</td> </tr> </table> <p>Play a 315 Hz, 0dB signal and measure the playback level</p>	REC	PLAY	BIAS	EQ	DOLBY	SELECTOR	OFF	ON	NORMAL	NORMAL	OFF	LINE	-6 dBs +2.0 dB -1.0 dB (CH level difference: 2 dB max.)
REC	PLAY	BIAS	EQ	DOLBY	SELECTOR												
OFF	ON	NORMAL	NORMAL	OFF	LINE												
2. Headphone Output Level	MTT-116U (MTT-216)	• 8Ω (1/2W) resistor • AC voltmeter	—	<p>Play a 315 Hz, 0dB signal. With PB VR set to the MAX position, connect a 8-ohm load resistor to the HEADPHONE output. Measure the output voltage across the resistor with AC voltmeter</p>	-24 dBs ± 3 dB (CH level difference: 3 dB max.)												
3. Playback S/N	MTT-116U (MTT-216)	• AC volt meter	—	<p>Play a 315 Hz, 0dB signal under the standard playback condition and measure the output level. Then, set the tape deck in pause mode and measure the output level. Obtain the ratio between the two output levels</p> <p>Also, measure the LINE output through a weighting circuit using the above procedure.</p>	42 dB min. (CH level difference 5 dB max.) 46 dB min. (CH level difference: 5 dB max.)												
4. Playback Frequency Response	MTT-116U (MTT-216)	• AC volt meter	—	<p>Under the standard playback condition, play each frequency on MTT-116U and measure the level at the LINE OUT terminal.</p>	See the figure at left												
5. Minimum Input Level				<table border="1" style="width: 100%; border-collapse: collapse; margin-bottom: 5px;"> <tr> <td>REC</td><td>PLAY</td><td>BIAS</td><td>EQ</td><td>DOLBY</td><td>SELECTOR</td> </tr> <tr> <td>OFF</td><td>OFF</td><td>NORMAL</td><td>NORMAL</td><td>OFF</td><td></td> </tr> </table>	REC	PLAY	BIAS	EQ	DOLBY	SELECTOR	OFF	OFF	NORMAL	NORMAL	OFF		
REC	PLAY	BIAS	EQ	DOLBY	SELECTOR												
OFF	OFF	NORMAL	NORMAL	OFF													
LINE	—	• Audio signal generator • AC voltmeter • Oscilloscope	1 kHz	<p>RECORD LEVEL MAX INPUT SELECTOR SW ... LINE</p> <p>Under the standard playback condition, apply a 1 kHz signal to LINE IN. Adjust the audio signal generator so that a signal of 0dBs (standard output level) is obtained at LINE OUT. Read the value of the input level at this condition.</p>	-20 dBs ± 3 dBs												
MIC	—	• Audio signal generator • AC voltmeter • Oscilloscope	1 kHz	<p>INPUT SELECTOR SW ... MIC</p> <p>Set other switches as shown above. Apply a 1 kHz signal to the MIC jack. Adjust the audio signal generator so that a signal of 0dBs (standard output level) is obtained at LINE OUT. Measure the input level at this condition.</p>	-72 dBs ± 3 dBs												
6. Overall Frequency Response	UD-XL1 AC-511	• Audio signal generator • AC voltmeter	40 Hz 100 Hz 1 kHz 6.3 kHz 10 kHz 13 kHz 16 kHz -30dBs each	<table border="1" style="width: 100%; border-collapse: collapse; margin-bottom: 5px;"> <tr> <td>REC</td><td>PLAY</td><td>BIAS</td><td>EQ</td><td>DOLBY</td><td>SELECTOR</td> </tr> <tr> <td>ON</td><td>ON</td><td></td><td></td><td></td><td>LINE</td> </tr> </table> <p>Set the DOLBY SW to OFF. Other switches should be set as shown above. Record and play each of the specified signals and check that the frequency response meets the specifications.</p> <p>Next, set the DOLBY SW to ON and check the frequency response of each signal.</p>	REC	PLAY	BIAS	EQ	DOLBY	SELECTOR	ON	ON				LINE	ALL POSITIONS DOLBY NR: OFF ALL POSITIONS DOLBY NR: ON
REC	PLAY	BIAS	EQ	DOLBY	SELECTOR												
ON	ON				LINE												
7. Distortion	UD-XL1 AC-511	• Audio signal generator • AC voltmeter • Distortion meter	1 kHz -10 dBs	<table border="1" style="width: 100%; border-collapse: collapse; margin-bottom: 5px;"> <tr> <td>REC</td><td>PLAY</td><td>BIAS</td><td>EQ</td><td>DOLBY</td><td>SELECTOR</td> </tr> <tr> <td>ON</td><td>ON</td><td></td><td></td><td></td><td>LINE</td> </tr> </table> <p>Under the standard recording and playback conditions, apply the specified signal to LINE IN. Record and play the signal and measure the distortion of the playback signal using a distortion meter. Measure distortion on each tape with the BIAS and EQ switches set to appropriate positions</p>	REC	PLAY	BIAS	EQ	DOLBY	SELECTOR	ON	ON				LINE	within 2%
REC	PLAY	BIAS	EQ	DOLBY	SELECTOR												
ON	ON				LINE												

MEASUREMENT (AMP)

Adjustment items	Tape used	Test instrument	Input signal	Conditions and methods	Standard and remarks																																		
8. Overall S/N	UD-XL1 AC-511	<ul style="list-style-type: none"> • Audio signal generator • AC voltmeter • Oscilloscope 	1 kHz -10 dBs	<table border="1" style="width: 100%; border-collapse: collapse; margin-bottom: 5px;"> <tr> <td>REC</td><td>PLAY</td><td>BIAS</td><td>EQ</td><td>DOLBY</td><td>SELECTOR</td> </tr> <tr> <td>ON</td><td>ON</td><td></td><td></td><td>OFF</td><td>LINE</td> </tr> </table> <p>Set the BIAS and EQ switches according to the type of tape used.</p> <p>Under the standard recording and playback conditions, apply the specified signal to LINE IN and record. Next, shut off the signal and set the tape deck in recording mode. Measure the playback levels with signal and without signal. Obtain the ratio between the two playback levels.</p> <p>Next, connect a weighting circuit between LINE OUT and AC voltmeter and measure the playback level in the same manner.</p> <p>Also, set the DOLBY SW to ON and measure in the same manner.</p>	REC	PLAY	BIAS	EQ	DOLBY	SELECTOR	ON	ON			OFF	LINE	<p>NORMAL</p> <table border="1" style="width: 100%; border-collapse: collapse; margin-bottom: 5px;"> <tr> <td rowspan="2">CONDITION</td> <td colspan="2">DOLBY</td> </tr> <tr> <td>OFF</td> <td>ON</td> </tr> <tr> <td>FLAT</td> <td>40 dBmin.</td> <td>47 dBmin.</td> </tr> <tr> <td>WEIGHTED</td> <td>44 dBmin.</td> <td>52 dBmin.</td> </tr> </table> <p>CrO₂</p> <table border="1" style="width: 100%; border-collapse: collapse;"> <tr> <td rowspan="2">CONDITION</td> <td colspan="2">DOLBY</td> </tr> <tr> <td>OFF</td> <td>ON</td> </tr> <tr> <td>FLAT</td> <td>42 dBmin.</td> <td>48 dBmin.</td> </tr> <tr> <td>WEIGHTED</td> <td>46 dB min.</td> <td>54 dBmin.</td> </tr> </table>	CONDITION	DOLBY		OFF	ON	FLAT	40 dBmin.	47 dBmin.	WEIGHTED	44 dBmin.	52 dBmin.	CONDITION	DOLBY		OFF	ON	FLAT	42 dBmin.	48 dBmin.	WEIGHTED	46 dB min.	54 dBmin.
REC	PLAY	BIAS	EQ	DOLBY	SELECTOR																																		
ON	ON			OFF	LINE																																		
CONDITION	DOLBY																																						
	OFF	ON																																					
FLAT	40 dBmin.	47 dBmin.																																					
WEIGHTED	44 dBmin.	52 dBmin.																																					
CONDITION	DOLBY																																						
	OFF	ON																																					
FLAT	42 dBmin.	48 dBmin.																																					
WEIGHTED	46 dB min.	54 dBmin.																																					
9. Erase ratio	UD-XL1	<ul style="list-style-type: none"> • Audio signal generator • AC voltmeter • 1 kHz band-pass filter 	1 kHz -4 dBs	<table border="1" style="width: 100%; border-collapse: collapse; margin-bottom: 5px;"> <tr> <td>REC</td><td>PLAY</td><td>BIAS</td><td>EQ</td><td>DOLBY</td><td>SELECTOR</td> </tr> <tr> <td>ON</td><td>ON</td><td>NORMAL</td><td>NORMAL</td><td>OFF</td><td>LINE</td> </tr> </table> <p>Under the standard recording and playback conditions, apply the specified signal to LINE IN. Record the signal and then rewind the tape slightly. Next, record the tape without applying signal. Rewind the tape and measure the ratio of the playback level with signal to the level without signal, using a 1 kHz band-pass filter.</p>	REC	PLAY	BIAS	EQ	DOLBY	SELECTOR	ON	ON	NORMAL	NORMAL	OFF	LINE	60 dB min.																						
REC	PLAY	BIAS	EQ	DOLBY	SELECTOR																																		
ON	ON	NORMAL	NORMAL	OFF	LINE																																		
10. Channel Separation	UD-XL1	<ul style="list-style-type: none"> • Audio signal generator • AC voltmeter • 1 kHz band-pass filter 	1 kHz -10 dBs	<table border="1" style="width: 100%; border-collapse: collapse; margin-bottom: 5px;"> <tr> <td>REC</td><td>PLAY</td><td>BIAS</td><td>EQ</td><td>DOLBY</td><td>SELECTOR</td> </tr> <tr> <td>ON</td><td>ON</td><td>NORMAL</td><td>NORMAL</td><td>OFF</td><td>LINE</td> </tr> </table> <p>Under the standard recording and playback conditions, apply the specified signal to one channel only. Record the signal on the channel. In this case, no signal is recorded on the other channel. Rewind and play the tape. Measure the ratio of the playback level with signal to the level without signal, using a 1 kHz band-pass filter.</p>	REC	PLAY	BIAS	EQ	DOLBY	SELECTOR	ON	ON	NORMAL	NORMAL	OFF	LINE	30 dB min.																						
REC	PLAY	BIAS	EQ	DOLBY	SELECTOR																																		
ON	ON	NORMAL	NORMAL	OFF	LINE																																		
11. Crosstalk between Tracks	UD-XL1	<ul style="list-style-type: none"> • Audio signal generator • AC voltmeter • 100 Hz band-pass filter 	100 Hz -10 dBs	<table border="1" style="width: 100%; border-collapse: collapse; margin-bottom: 5px;"> <tr> <td>REC</td><td>PLAY</td><td>BIAS</td><td>EQ</td><td>DOLBY</td><td>SELECTOR</td> </tr> <tr> <td>ON</td><td>ON</td><td>NORMAL</td><td>NORMAL</td><td>OFF</td><td>LINE</td> </tr> </table> <p>Under the standard recording and playback conditions, apply the specified signal to LINE IN. Record the signal. Next, reverse the cassette and play the tape. Measure the crosstalk using a 100 Hz band-pass filter.</p>	REC	PLAY	BIAS	EQ	DOLBY	SELECTOR	ON	ON	NORMAL	NORMAL	OFF	LINE	30																						
REC	PLAY	BIAS	EQ	DOLBY	SELECTOR																																		
ON	ON	NORMAL	NORMAL	OFF	LINE																																		
12. Bias Leak	—	• AC voltmeter	—	<table border="1" style="width: 100%; border-collapse: collapse; margin-bottom: 5px;"> <tr> <td>REC</td><td>PLAY</td><td>BIAS</td><td>EQ</td><td>DOLBY</td><td>SELECTOR</td> </tr> <tr> <td>ON</td><td>ON</td><td>NORMAL</td><td>NORMAL</td><td>OFF</td><td>LINE</td> </tr> </table> <p>Under the standard recording and playback conditions, operate the tape mechanism without loading tape. Measure the output levels</p>	REC	PLAY	BIAS	EQ	DOLBY	SELECTOR	ON	ON	NORMAL	NORMAL	OFF	LINE	-50 dBs max.																						
REC	PLAY	BIAS	EQ	DOLBY	SELECTOR																																		
ON	ON	NORMAL	NORMAL	OFF	LINE																																		
13. REC MUTE effect	UD-XL1	<ul style="list-style-type: none"> • Audio signal generator • AC voltmeter 	1 kHz. -10dBs	<p>Under the standard recording and playback conditions, apply the specified signal to LINE IN. Record the signal. Measure output levels with REC MUTE ON and OFF.</p>	48 dB min.																																		

POWER SUPPLY (X27-1430-) Component side view**

REC/PLAY (X25)

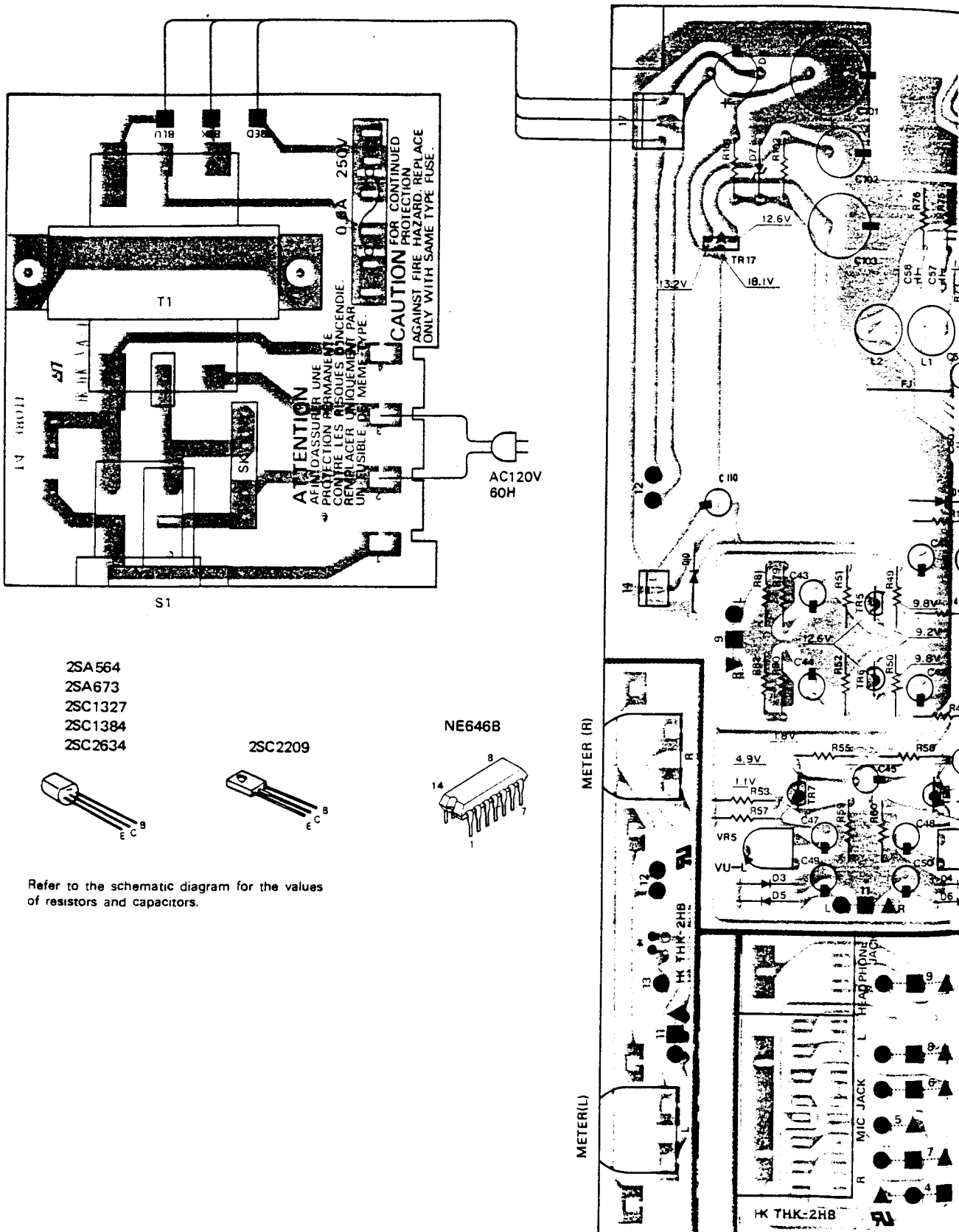

- 2SA564
- 2SA673
- 2SC1327
- 2SC1384
- 2SC2634

2SC2209

NE646B

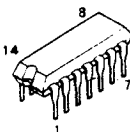
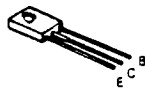
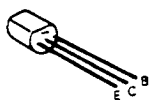

Refer to the schematic diagram for the values of resistors and capacitors.

KX-400 KX-400

PC BOARD

30-**) Component side view

REC/PLAY (X25-1570-**) Component side view

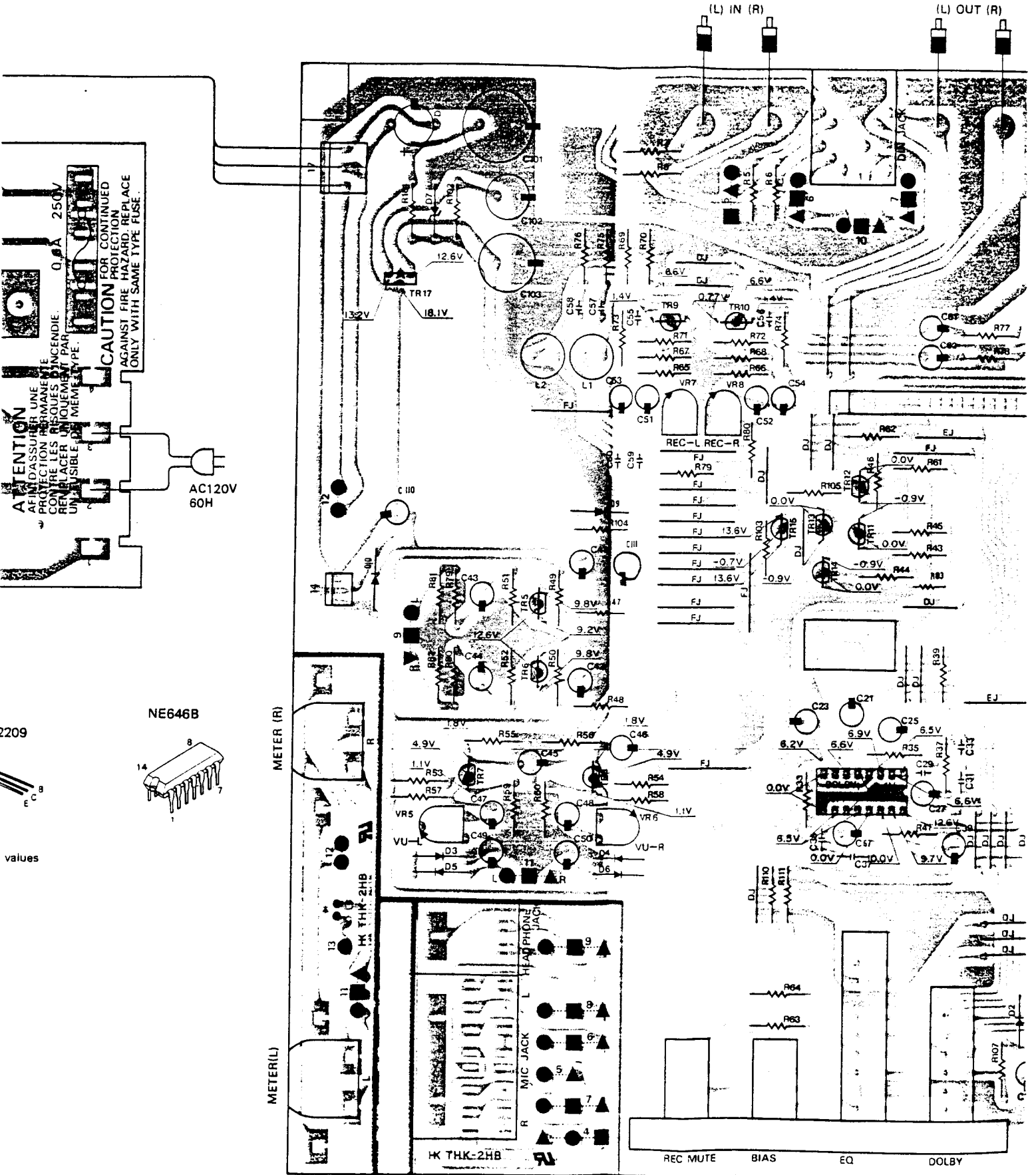

KX-400

BOARD

.1570-**) Component side view

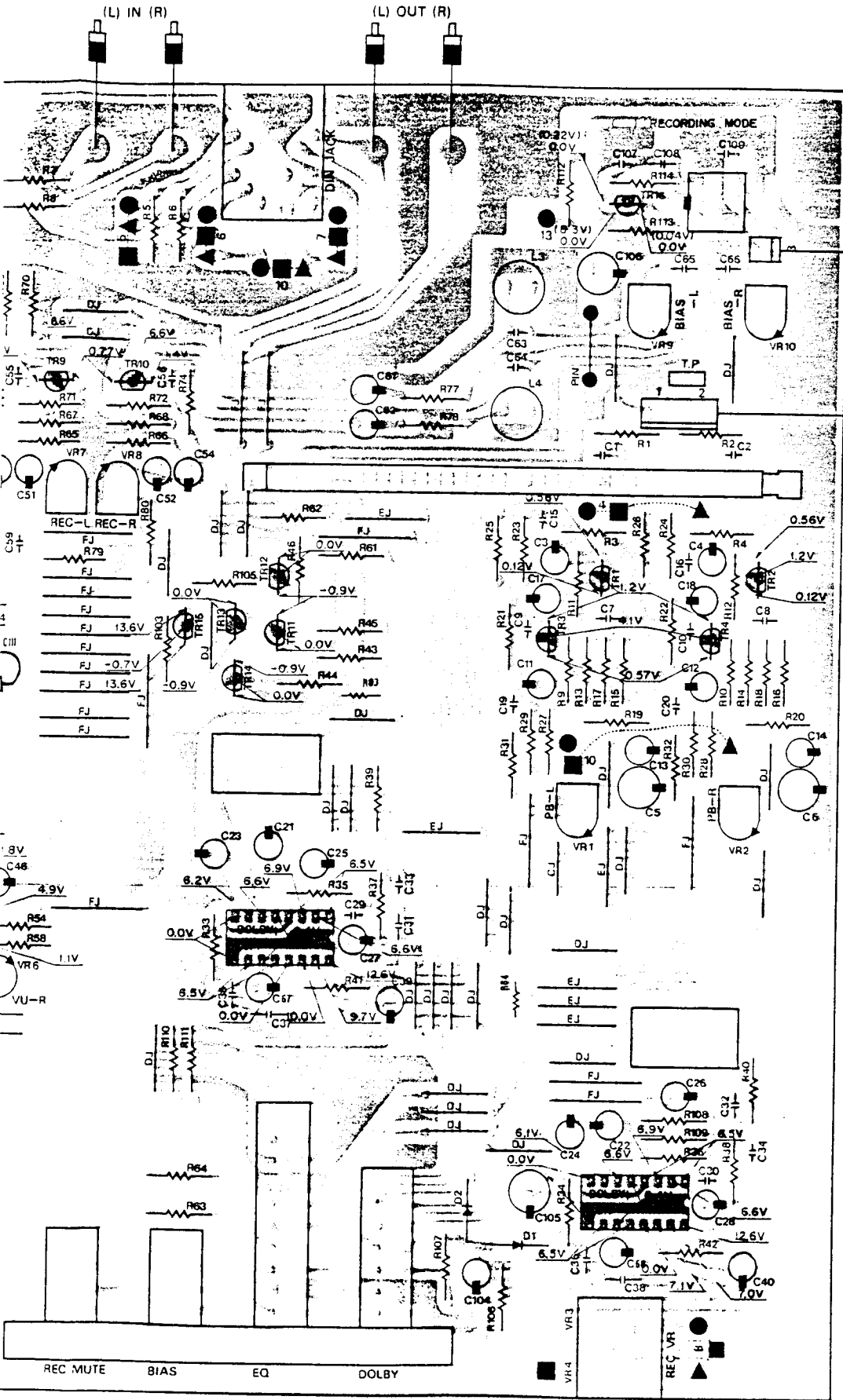

Adjustment and Test points
BIAS OSC L7,R113
BIAS CURRENT VR9,10
REC CURRENT C61,R77 C62,R78 VR7,8
PLAY BACK VR1,2
VU METER VR5,6

2SA564
2SA673
2SC1327
2SC1384
2SC2634

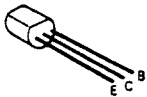

2SC2209

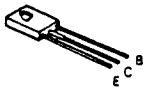

NE646B

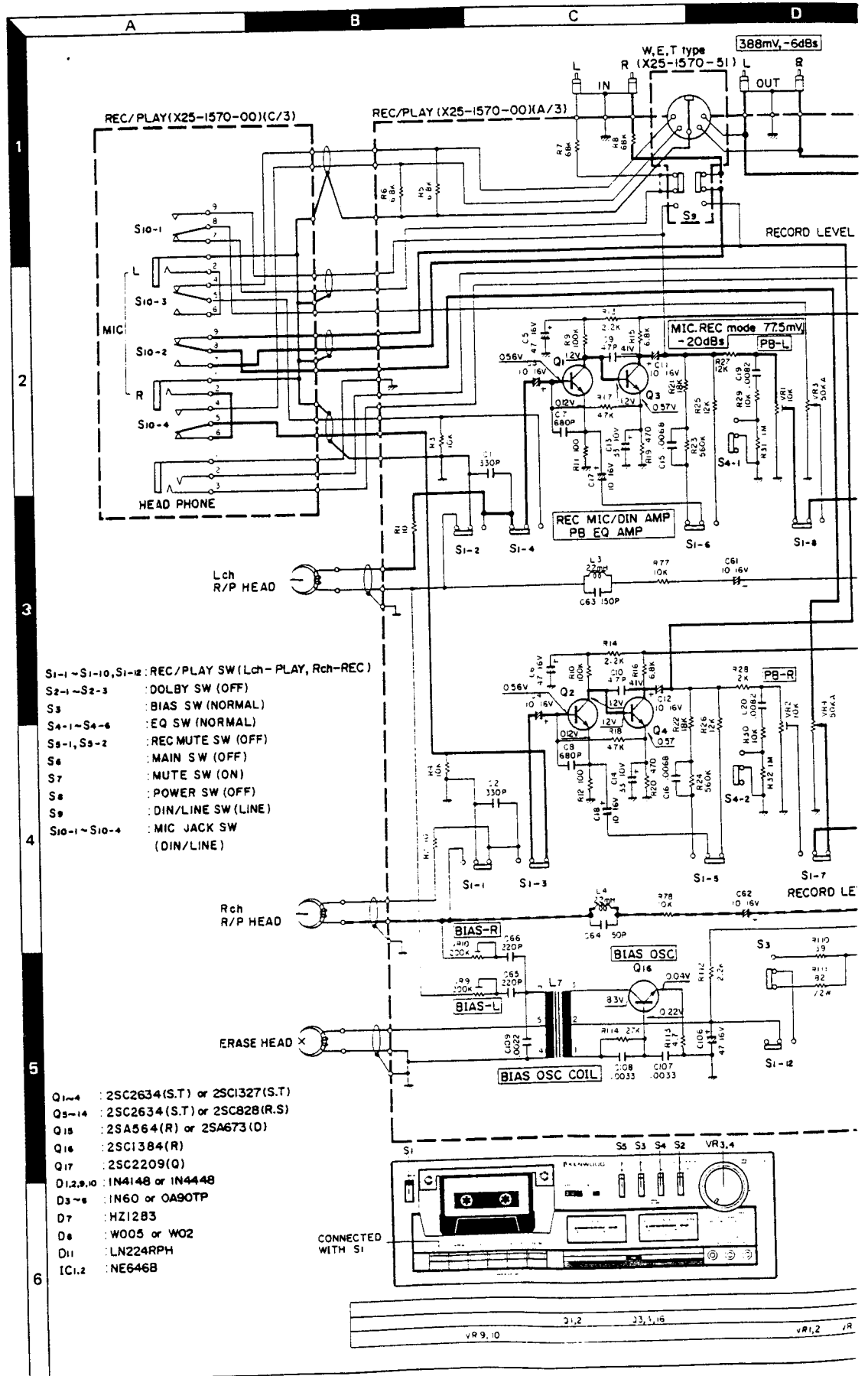
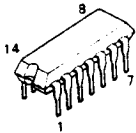

- S1-1 ~ S1-10, S1-12 : REC/PLAY SW (Lch-PLAY, Rch-REC)
- S2-1 ~ S2-3 : DOLBY SW (OFF)
- S3 : BIAS SW (NORMAL)
- S4-1 ~ S4-6 : EQ SW (NORMAL)
- S5-1, S5-2 : REC MUTE SW (OFF)
- S6 : MAIN SW (OFF)
- S7 : MUTE SW (ON)
- S8 : POWER SW (OFF)
- S9 : DIN/LINE SW (LINE)
- S10-1 ~ S10-4 : MIC JACK SW (DIN/LINE)

- Q1-4 : 2SC2634 (S.T) or 2SC1327 (S.T)
- Q5-14 : 2SC2634 (S.T) or 2SC828 (R.S)
- Q15 : 2SA564 (R) or 2SA673 (D)
- Q16 : 2SC1384 (R)
- Q17 : 2SC2209 (Q)
- D1, 2, 9, 10 : IN4148 or IN4448
- D3-6 : IN60 or OA90TP
- D7 : HZ12B3
- D8 : W005 or W02
- D11 : LN224RPH
- IC1, 2 : NE646B

STEREO CASSETTE DECK

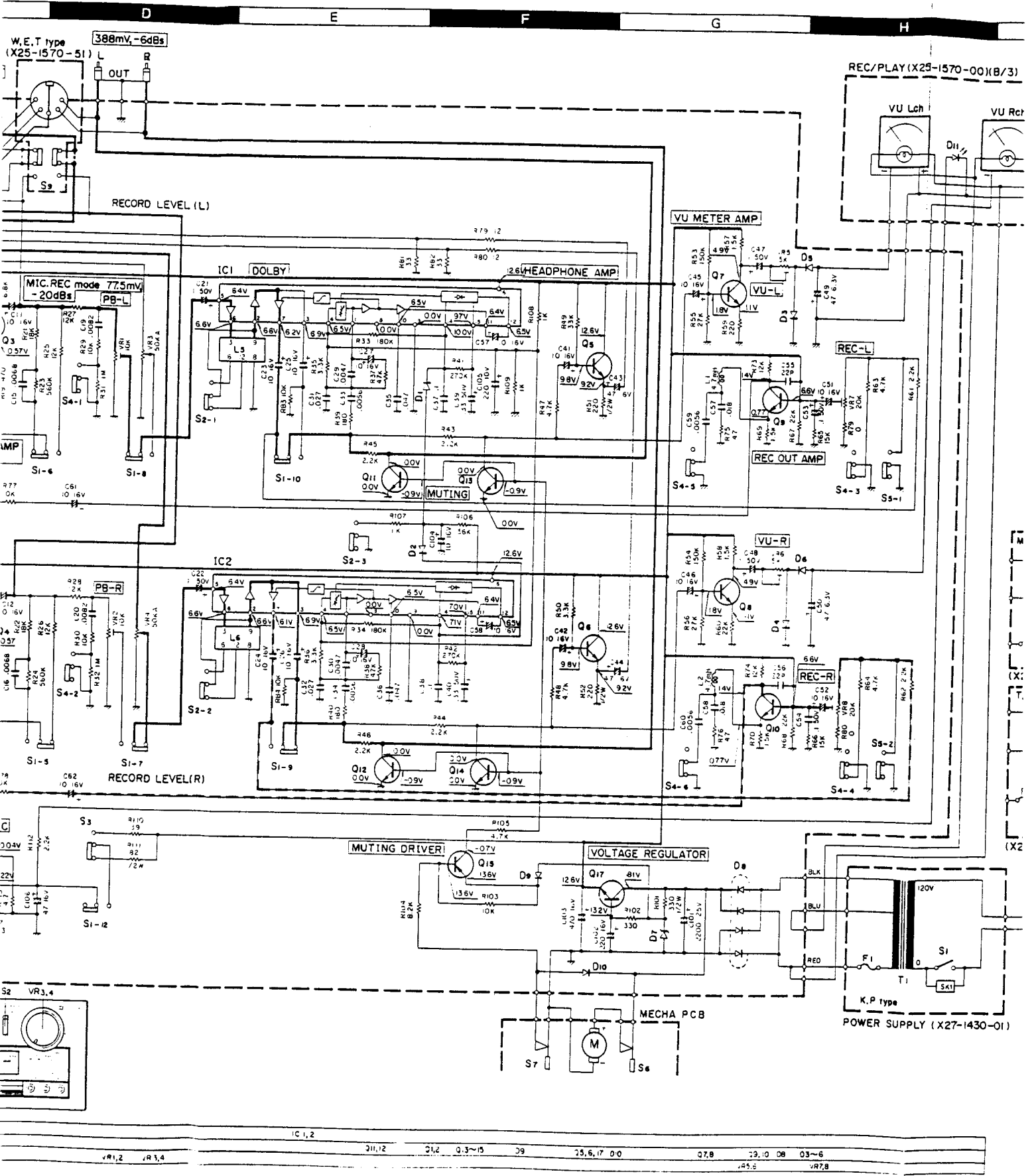

All DC voltage values except those of bias circuit & trimmer (25 kΩ/V) with a cassette loaded in the DC voltages of bias circuit are measured in the

KX-440(G) KX-400(B)

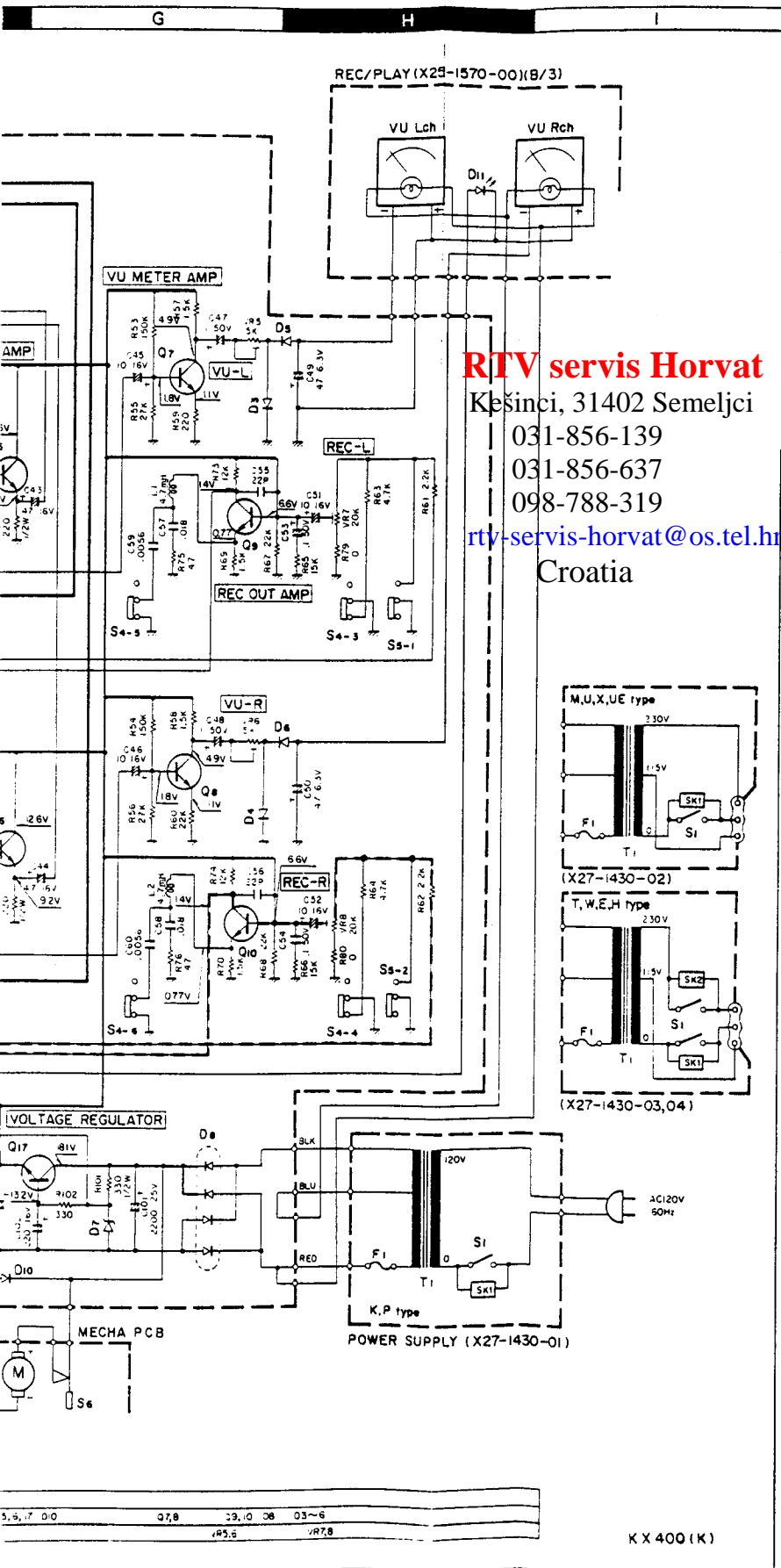

RTV servis Horvat

Košinci, 31402 Semeljci

031-856-139

031-856-637

098-788-319

rtv-servis-horvat@os.tel.hr

Croatia

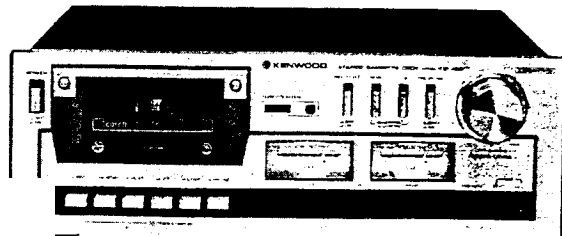

IFICATIONS

.....	Front Loading Stereo Cassette Deck with Dolby NR System
Item	4-Track, 2-Channel Stereo-Mono Recording/Playback System
System	AC Bias System (Bias Frequency: 85 kHz)
System	AC System
Speed	4.76 cm/sec. (1-7/8 ips)
.....	Record and Playback Head x 1 (Hard Permalloy)
.....	Erase Head x 1 (Ferrite)
.....	Electronically-Controlled DC Motor
Fast Winding Time	Approx. 85 seconds with C-60 tape
Frequency Response:	
Normal Tape	30 Hz to 14,000 Hz (40 Hz to 13,000 Hz, ±3 dB)
Chrome Tape	30 Hz to 16,000 Hz (40 Hz to 15,000 Hz, ±3 dB)
Signal to Noise Ratio:	
Dolby NR ON (Over 5 kHz)	60 dB (Normal Tape), 62 dB (Chrome Tape)
Dolby NR OFF	50 dB (Normal Tape), 52 dB (Chrome Tape)
Harmonic Distortion	Less than 1.5% (at 1 kHz, 0 VU with Normal Tape)
Wow and Flutter	0.05% (W.R.M.S.)
Input Sensitivity/Impedance:	
LINE x 2	77.5 mV/50k ohms
DIN x 1	0.1 mV/k ohms: Europe and U.K. Models only
Microphone x 2	0.2 mV/10k ohms
Output Level/Load Impedance:	
LINE x 2	390 mV (0 VU)/100k ohms
DIN x 1	390 mV (0 VU)/100k ohms: Europe and U.K. Models only
Headphones x 1	49 mV/8 ohms
Built-in Features	Dolby Noise Reduction System Two Position Bias Selector (Normal-Chrome) Two Position Equalization Selector (Normal-Chrome) Full Auto Shut-Off Mechanism in all Modes Recording Mute Timer Stand by Mechanism LED Recording Indicator Three-Digit Tape Counter Two Large Illuminated VU Meters Two Microphone Jacks, Headphone Jack DIN Recording/Playback Connector (Europe and U.K. Models only)
Power Requirements	AC 120V, 60 Hz: USA and Canada Models AC 120V/220-240V (Switchable), 50/60 Hz: Other Countries
Power Consumption	80 watts
Dimensions (KX-400)	W: 400 mm (15-3/4") H: 139 mm (5-1/2") D: 287 mm (11-5/16")
Dimensions (KX-440)	W: 440 mm (17-5/16") H: 140 mm (5-1/2") D: 287 mm (11-5/16")
Weight (KX-400)	4.9 kg (10.8 lbs)
Weight (KX-440)	5.2 kg (11.5 lbs)
Supplied Accessories	Head Cleaning Set - 1 Head Cover x 1
Reference Tape	Normal: MAXELL XLI C 60 Chrome: TDK SA C-60

Kenwood follows a policy of continuous advancements in development. For this reason specifications may be changed without notice.

Kenwood strebt ständige Verbesserungen in der Entwicklung an. Daher bleiben Änderungen der technischen Daten jederzeit vorbehalten.

Kenwood poursuit une politique de progrès constants en ce qui concerne le développement. Pour cette raison, les spécifications sont sujettes à modifications sans préavis.

All DC voltage values except those of bias circuit are measured with a multimeter (25 kΩ/V) with a cassette loaded in the playback mode. DC voltages of bias circuit are measured in the recording mode.

PARTS LIST

INSTRUCTION FOR PARTS LIST

Ref. No. 参照番号	Parts No. 部品番号	Description 部品名/規格	Re- marks 備考
②	①	11 1A AC1-0613-02 CASE 400	③
		11 1A AC1-0613-02 CASE 400b	
		11 1A A01-0616-08 CASE 440	
		11 1A A01-0617-08 CASE 440G	
		12 3A A20-2012-08 FRONT PANEL 400	④
⑥		R221 R43-1333-15 FL-PROOF RD330 J 2M	⑦
		R222 R43-1368-15 FL-PROOF RD680 J 2M	
		VR1 ,2 R12-3301-05 TRIMMING POT. 20K(B)	
		VR3 ,4 R19-4305-05 POTENTIOMETER (OUTPUT)	
		VR5 ,6 R12-2302-05 TRIMMING POT. 5K(B)	

- Exploded view drawing No
 - Position in exploded view
 - Symbol of new parts
 - Area to which parts are shipped Example: A20-2012-08 is the parts No. of FRONT PANEL for the "K" type products (for USA).
 - 400 is in use for "KX-400".
 - 400b is in use for "KX-400B".
 - 440 is in use for "KX-440".
 - 440G is in use for "KX-440G".

When this part is blank, it means that the same type of parts (same parts No.) are used for all of above.
 - Reference No. in schematic diagram
 - Abbreviation of "ceramic capacitor"
- All capacitors and resistors are listed using abbreviations.
- Abbreviations
 - Abbreviations of capacitors (Parts No. with initial letter "C")
 - ELECTRO Electrolytic capacitor
 - LL-ELEC Low leak electrolytic capacitor
 - NP-ELEC Non-pole electrolytic capacitor
 - MICA Mica capacitor
 - POLYSTY Polystyrene capacitor
 - MYLAR Mylar capacitor
 - CERAMIC Ceramic capacitor
 - TANTAL Tantalum capacitor
 - MF Metallized film capacitor
 - MP Metallized paper capacitor
 - OIL Oil capacitor

The unit "UF" is used in lieu of "μF".
 - Abbreviations of resistors (Parts No. with initial letters "R")
 - RC Carbon composition resistor
 - RD Carbon film resistor
 - FL-PROOF RD Flame-proof carbon film resistor
 - RW Wire wound power resistor
 - FL-PROOF RS Flame-proof metal oxide film resistor
 - RN Metal film resistor
 - FUSE-RESIST Resistor with fuse function
 - 2B Rated wattage 1/8W
 - 2E Rated wattage 1/4W
 - 2H Rated wattage 1/2W
 - 3A Rated wattage 1W
 - 3D Rated wattage 2W
 - 3F Rated wattage 3W
 - 3G Rated wattage 4W
 - 3H Rated wattage 5W

All resistor values are indicated with the unit (Ω) omitted.
 - Abbreviations common to capacitors and resistors
 - C ±0.25pF (Used for capacitors only)
 - D ±0.5pF (Used for capacitors only)
 - F ±1%
 - G ±2%
 - J ±5%
 - K ±10%
 - M ±20%
 - Z +80% -20% (Used for capacitors only)
 - P +100% -0% (Used for capacitors only)
 - Resistors RD (carbon composition resistors) are not listed in the parts list. For values, refer to the schematic diagram.

Ref. No. 参照番号	Parts No. 部品番号	Description 部品名/規格	Re- marks 備考	Ref. I 参照
KX-400(B),440(G)(UNIT)				
1	3B	-		19 2A
2	1B	BOTTOM PLATE		20 1E
3	2B	REAR PANEL		20 1B
		PC BOARD HOLDER		20 1E
				20 1B
11	1A	AC1-0613-08 CASE 400	*	20 1E
11	1A	A01-0613-08 CASE 400b	*	20 1E
11	1A	A01-0616-08 CASE 440	*	20 1B
11	1A	A01-0617-08 CASE 440G	*	21 2A
12	3A	A20-2012-08 FRONT PANEL 400	*K	
12	3A	A20-2012-08 FRONT PANEL 400	PU	22 1B
12	3A	A20-2012-08 FRONT PANEL 400	MX	22 1B
12	3A	A20-2012-08 FRONT PANEL 400	w	22 1B
12	3A	A20-2012-08 FRONT PANEL 400	UE	22 1B
12	3A	A20-2012-08 FRONT PANEL 400	*T	
12	3A	A20-2017-08 FRONT PANEL 400b	*	22 1B
12	3A	A20-2018-08 FRONT PANEL 440	*T	22 1B
12	3A	A20-2018-08 FRONT PANEL 440G	*T	23 1B
12	3A	A20-2019-08 FRONT PANEL 440	*U	24 1B
12	3A	A20-2019-08 FRONT PANEL 440	MX	
12	3A	A20-2019-08 FRONT PANEL 440	E	-
12	3A	A20-2019-08 FRONT PANEL 440G	*E	-
13	2A	A22-0615-08 SUB PANEL 400	*	-
13	2A	A22-0615-08 SUB PANEL 400b	*	-
13	2A	A22-0618-08 SUB PANEL 440	*	-
13	2A	A22-0618-08 SUB PANEL 440G	*	-
14	2B	A35-0212-08 COUNTER	*	-
-		B46-0055-20 WARRANTY CARD	P	-
-		B46-0060-00 WARRANTY CARD	T	-
-		B46-0061-20 WARRANTY CARD	K	-
-		B46-0062-20 WARRANTY CARD	J	-
-		B46-0062-20 WARRANTY CARD	UE	-
-		B46-0063-13 WARRANTY CARD	U	-
-		B46-0064-00 WARRANTY CARD	X	-
-		B50-2392-00 INSTRUCTION MANUAL 400	*K	-
-		B50-2392-00 INSTRUCTION MANUAL 400	U	-
-		B50-2392-00 INSTRUCTION MANUAL 400	UE	-
-		B50-2393-00 INSTRUCTION MANUAL 400	*P	-
-		B50-2393-00 INSTRUCTION MANUAL 400	MX	-
-		B50-2393-00 INSTRUCTION MANUAL 400b	MX	-
-		B50-2394-00 INSTRUCTION MANUAL 400	*T	-
-		B50-2413-00 INSTRUCTION MANUAL 400	*W	-
-		B50-2414-00 INSTRUCTION MANUAL 440	*M	-
-		B50-2414-00 INSTRUCTION MANUAL 440	UX	-
-		B50-2415-00 INSTRUCTION MANUAL 440	*T	-
-		B50-2415-00 INSTRUCTION MANUAL 440G	*T	-
-		B50-2416-00 INSTRUCTION MANUAL 440	*M	-
-		B50-2416-00 INSTRUCTION MANUAL 440	E	25 3B
-		B50-2416-00 INSTRUCTION MANUAL 440G	E	25 3B
-		B59-0018-00 SERVICE STATIONS LIST	U	25 3B
-		B59-0018-00 SERVICE STATIONS LIST	UE	26 1E
15	3A	803-0438-08 DRESS PLATE	*	
16	3A	807-0811-08 CASSETTE COVER 400	*	27 3A
16	3A	807-0811-08 CASSETTE COVER 440	*	27 3A
16	3A	807-0811-08 CASSETTE COVER 440G	*	27 3A
16	3A	807-0814-08 CASSETTE COVER 400b	*	28 3A
17	3A	807-0812-08 DRESS RING 400	*	
17	3A	807-0812-08 DRESS RING 400b	*	28 3A
17	3A	807-0816-08 DRESS RING 440	*	28 3A
17	3A	807-0816-08 DRESS RING 440G	*	29 1A
18	3A	807-0813-08 HEAD COVER	*	30 2B

PARTS LIST

Ref. No. 参照番号	Parts No. 部品番号	Description 部品名 / 規格	Re- marks 備考
31 2A	X29-0904-08	KEY(MECHANISM)	*
32 1A	N09-0916-05	SCREW M3X10	440 *
32 1A	N09-0916-05	SCREW M3X10	440G *
33 2B	N29-0053-05	NYLON SCREW(3X4.5)	WT *
33 2B	N29-0053-05	NYLON SCREW(3X4.5)	E
34 2B	N29-0216-05	NYLON SCREW(3.5X5.5)	
35 1B	N09-0948-05	SCREW M4X22	*
36 2A,2B	S90-0308-08	FLEX WIRE(REC/PLAY SW)	*
-	T32-0013-08	ERASE HEAD	*
-	T34-0013-08	REC/P.B. HEAD	*
-	T42-0118-08	DC MOTOR	*
-	W01-0301-05	CLEANING STICK	
37 2B,3B	X25-1570-00	REC/PLAY PCB ASSY	*K
37 2B,3B	X25-1570-00	REC/PLAY PCB ASSY	PU
37 2B,3B	X25-1570-00	REC/PLAY PCB ASSY	MX
37 2B,3B	X25-1570-00	REC/PLAY PCB ASSY	UE
37 2B,3B	X25-1570-51	REC/PLAY PCB ASSY	*W
37 2B,3B	X25-1570-51	REC/PLAY PCB ASSY	ET
38 1B	X27-1430-01	POWER SUPPLY PCB ASSY	*K
38 1B	X27-1430-01	POWER SUPPLY PCB ASSY	P
38 1B	X27-1430-02	POWER SUPPLY PCB ASSY	U
38 1B	X27-1430-02	POWER SUPPLY PCB ASSY	MX
38 1B	X27-1430-02	POWER SUPPLY PCB ASSY	UE
38 1B	X27-1430-03	POWER SUPPLY PCB ASSY	*T
38 1B	X27-1430-04	POWER SUPPLY PCB ASSY	*W
38 1B	X27-1430-04	POWER SUPPLY PCB ASSY	E
REC/PLAY(X25-1570)			
-	B31-0517-08	VU METER	*
C1 ,2	C71-1733-16	CERAMIC 330PF	K
C3 ,4	C25-1210-61	LL-ELEC 10UF	16WV
C5 ,6	C24-1247-61	ELECTRO 47UF	16WV
C7 ,8	C71-1768-16	CERAMIC 680PF	K
C9 ,10	C71-1747-06	CERAMIC 47PF	K
C11 ,12	C24-1210-61	ELECTRO 10UF	16WV
C13 ,14	C24-1033-61	ELECTRO 33UF	10WV
C15 ,16	C45-1768-25	MYLAR 0.0068UF	J
C17 ,18	C24-1210-61	ELECTRO 10UF	16WV
C19 ,20	C45-1782-25	MYLAR 0.0082UF	J
C21 ,22	C25-1710-51	LL-ELEC 1UF	50WV
C23 ,28	C24-1210-61	ELECTRO 10UF	16WV
C29 ,30	C45-1747-25	MYLAR 0.0047UF	J
C31 ,32	C45-1727-35	MYLAR 0.027UF	J
C33 ,34	C45-1756-25	MYLAR 0.0056UF	J
C35 ,36	C45-1747-35	MYLAR 0.047UF	J
C37 ,38	C45-1710-45	MYLAR 0.1UF	J
C39 ,40	C25-1733-41	LL-ELEC 0.33UF	50WV
C41 ,42	C24-1210-61	ELECTRO 10UF	16WV
C43 ,44	C24-1247-61	ELECTRO 47UF	16WV
C45 ,46	C24-1210-61	ELECTRO 10UF	16WV
C47 ,48	C24-1710-51	ELECTRO 1UF	50WV
C49 ,50	C24-1047-61	ELECTRO 47UF	6.3WV
C51 ,52	C24-1210-61	ELECTRO 10UF	16WV
C53 ,54	C25-1710-41	LL-ELEC 0.1UF	50WV
C55 ,56	C71-1722-06	CERAMIC 22PF	K
C57 ,58	C45-1722-35	MYLAR 0.022UF	J
C59 ,60	C45-1756-25	MYLAR 0.0056UF	J
C61 ,62	C24-1210-61	ELECTRO 10UF	16WV
C63 ,64	C41-1715-15	MICA 150PF	J

Ref. No. 参照番号	Parts No. 部品番号	Description 部品名 / 規格	Re- marks 備考
C65 ,66	C41-1722-15	MICA 220PF	J
C67 ,68	C24-1210-61	ELECTRO 10UF	16WV
C101	C24-1422-81	ELECTRO 220UF	25WV
C102	C24-1222-71	ELECTRO 220UF	16WV
C103	C24-1247-71	ELECTRO 470UF	16WV
C104	C24-1210-61	ELECTRO 10UF	16WV
C105	C24-1022-71	ELECTRO 220UF	10WV
C106	C24-1247-61	ELECTRO 47UF	16WV
C107,108	C45-1733-25	MYLAR 0.0033UF	J
C109	C45-1722-25	MYLAR 0.0022UF	J
C110	C24-1447-61	ELECTRO 47UF	25WV
C111	C24-1222-71	ELECTRO 220UF	16WV
-	E11-0317-08	PHONE JACK (MIC)	*
-	E11-0318-08	PHONE JACK (HEAD PHONE)	*
L1 ,2	L33-0502-08	FIXED INDUCTOR 3.9MH	*
L3 ,4	L33-0503-08	FIXED INDUCTOR 22MH	*
L5 ,6	L39-0316-08	LOW PASS FILTER	*
L7	L32-0510-08	OSC COIL	*
R101,102	R43-1333-15	FL-PROOF R0330	J 2H
R110	R92-0223-05	FUSE-RESIST39	J 2E
R111	R43-1382-05	FL-PROOF R082	J 2H
R113	R43-1347-95	FL-PROOF R04.7	J 2H
VR1 ,2	R12-3044-08	TRIMMING POT. 10K	*
VR3 ,4	R19-4309-08	POTENTIOMETER	*
VR5,6	R12-2301-08	TRIMMING POT. 5K	*
VR7 ,8	R12-3046-08	TRIMMING POT. 20K	*
VR9 ,10	R12-5304-08	TRIMMING POT. 200K	*
-	S31-2310-08	DIN CONNECTOR WITH SW	*E
-	S31-2310-08	DIN CONNECTOR WITH SW	WT
S1	S31-0309-08	REC/PLAY SWITCH	*
S2 -5	S40-4306-08	PUSH SWITCH	*
01 ,2	V11-2101-70	1N4148	*
01 ,2	V11-7766-06	1N4448	*
02 -6	V11-0051-05	1N60	*
03 -6	V11-0197-05	0A90TP	*
03 -6	V11-9990-05	1S188AM-TP	*
07	V11-2102-60	H212B3	*
08	V11-2400-20	W02	*
08	V11-2400-90	W005	*
09 ,10	V11-2101-70	1N4148	*
09 ,10	V11-7766-06	1N4448	*
011	V11-1100-30	LN224RPH	*
IC1 ,2	V30-0316-20	NE646B	*
Q1 -4	V03-1327-20	2SC1327(S,T)	*
Q1 -4	V03-2634-10	2SC2634(S,T)	*
Q5 -14	V03-0362-05	2SC828(R,S)	*
Q5 -14	V03-1815-16	2SC1815(G,R)	*
Q5 -14	V03-2634-10	2SC2634(S,T)	*
Q15	V01-0081-05	2SA673(D)	*
Q15	V01-1613-05	2SA564(R,S)	*
Q16	V03-0388-05	2SC1384(R)	*
C17	V03-2209-10	2SC2209(Q)	*
POWER SUPPLY(X27-1430)			
SK1	C91-0023-05	SPARK KILLER	*M
SK1	C91-0023-05	SPARK KILLER	UX
SK1	C91-0023-05	SPARK KILLER	UE
SK1	C91-0072-05	SPARK KILLER	*K
SK1	C91-0072-05	SPARK KILLER	P
SK1	C91-0079-05	SPARK KILLER	WT
SK1	C91-0079-05	SPARK KILLER	E

PARTS LIST

Ref. No. 参照番号	Parts No. 部品番号	Description 部品名 / 規格	Re- marks 備考
-	E03-0104-08	POWER VOLTAGE SELECTOR	*K
-	E03-0104-08	POWER VOLTAGE SELECTOR	UX
-	E03-0104-08	POWER VOLTAGE SELECTOR	WT
-	E03-0104-08	POWER VOLTAGE SELECTOR	UE
-	E03-0104-08	POWER VOLTAGE SELECTOR	E
F1	F05-5015-05	FUSE F0.5A 250V	WT
F1	F05-5015-05	FUSE F0.5A 250V	E
F1	F05-6014-05	FUSE 0.6A 250V	KP
F1	F06-1014-08	FUSE 0.5A 250V	UM
F1	F06-1014-08	FUSE 0.5A 250V	X
F1	F06-1014-08	FUSE 0.5A 250V	UE
-	J13-0047-08	FUSE HOLDER	*K
-	J13-0047-08	FUSE HOLDER	PU
-	J13-0047-08	FUSE HOLDER	MX
-	J13-0047-08	FUSE HOLDER	UE
-	J13-0048-08	FUSE HOLDER	*W
-	J13-0048-08	FUSE HOLDER	ET
T1	L01-6331-08	POWER TRANSFORMER	*K
T1	L01-6331-08	POWER TRANSFORMER	P
T1	L01-6334-08	POWER TRANSFORMER	*M
T1	L01-6334-08	POWER TRANSFORMER	UX
T1	L01-6334-08	POWER TRANSFORMER	WT
T1	L01-6334-08	POWER TRANSFORMER	UE
T1	L01-6334-08	POWER TRANSFORMER	E
S1	S33-1307-08	PUSH SWITCH (POWER)	*K
S1	S33-1307-08	PUSH SWITCH (POWER)	PU
S1	S33-1307-08	PUSH SWITCH (POWER)	MX
S1	S33-1307-08	PUSH SWITCH (POWER)	UE
S1	S33-2309-08	PUSH SWITCH (POWER)	*W
S1	S33-2309-08	PUSH SWITCH (POWER)	ET

KX-400

SUPPLEMENT

OPERATION OF MECHANISM

1. AUTO-SHUT OFF

When the tape reaches the end in every mode, cam of the stop cam ass'y sets sensor plate. Hook cam depresses the sensor plate to release the lock mechanism ① ~ ⑦. In normal operation, as sensor pulley depresses sensor plate to

reset the mechanism, the lock mechanism cannot be released. The sensor pulley with the slip mechanism using felt is rotated by reel pulley ass'y A and depresses the sensor plate.

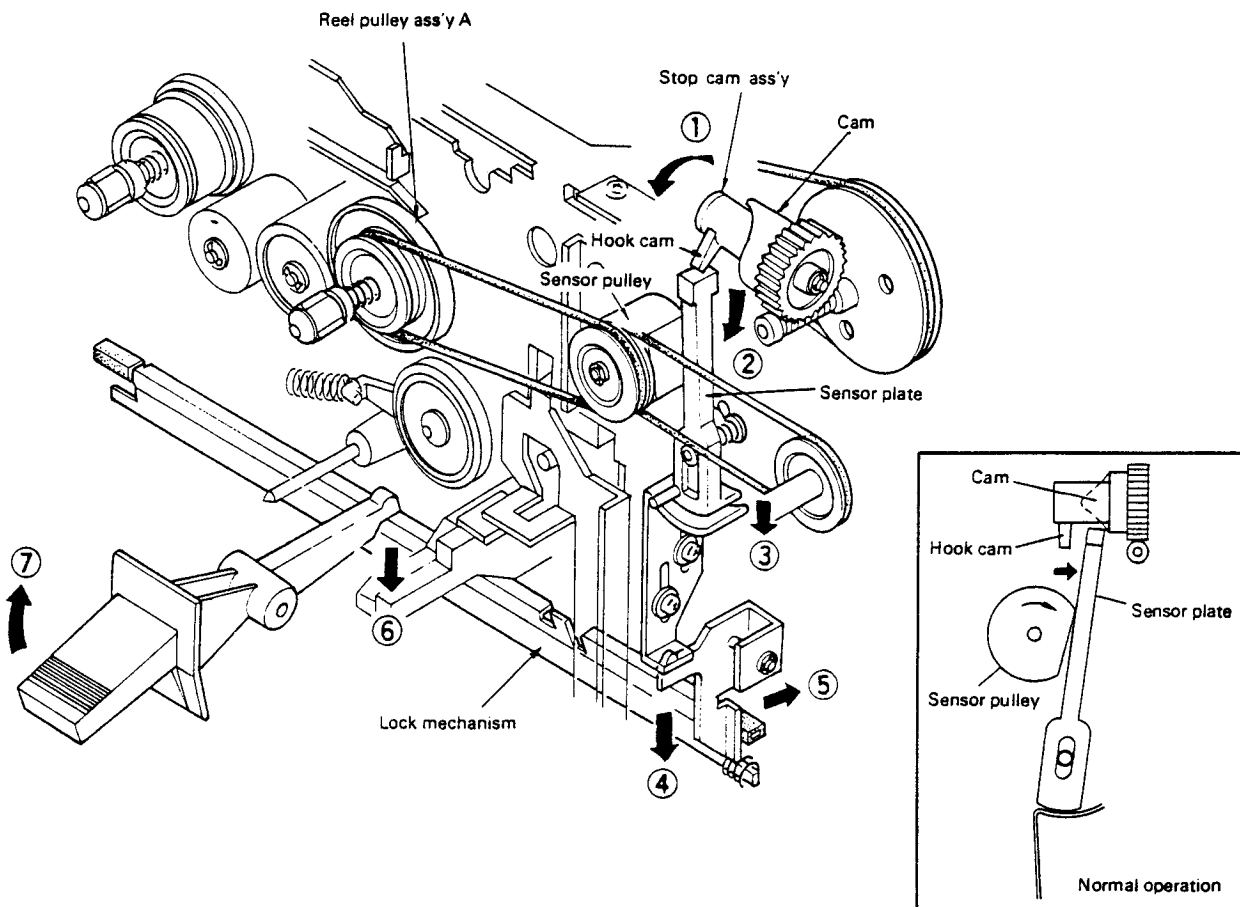

Fig. 1 Automatic Shut-off

OPERATION OF MECHANISM

2. TIMER STANDBY (Timer Start)

When the PLAY button is depressed ①, the pinch roller is shifted to the capstan by the spring. The pinch roller protector comes in contact with the capstan pulley beforehand, to the pinch roller (Fig. A). When the power is turned on by the timer, the motor and

capstan pulley start rotating ②. Then the pinch roller protector is released ③ and the pinch roller comes in contact with the capstan (Fig. B). The pinch roller protector is reset when the pinch roller moves away from the capstan.

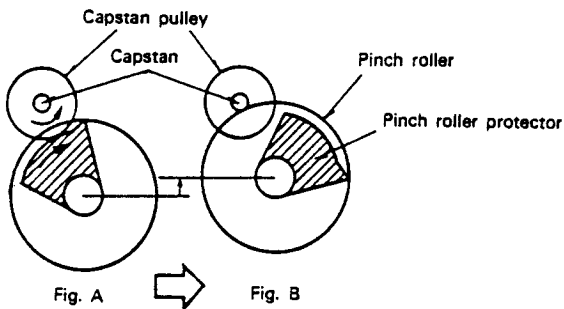
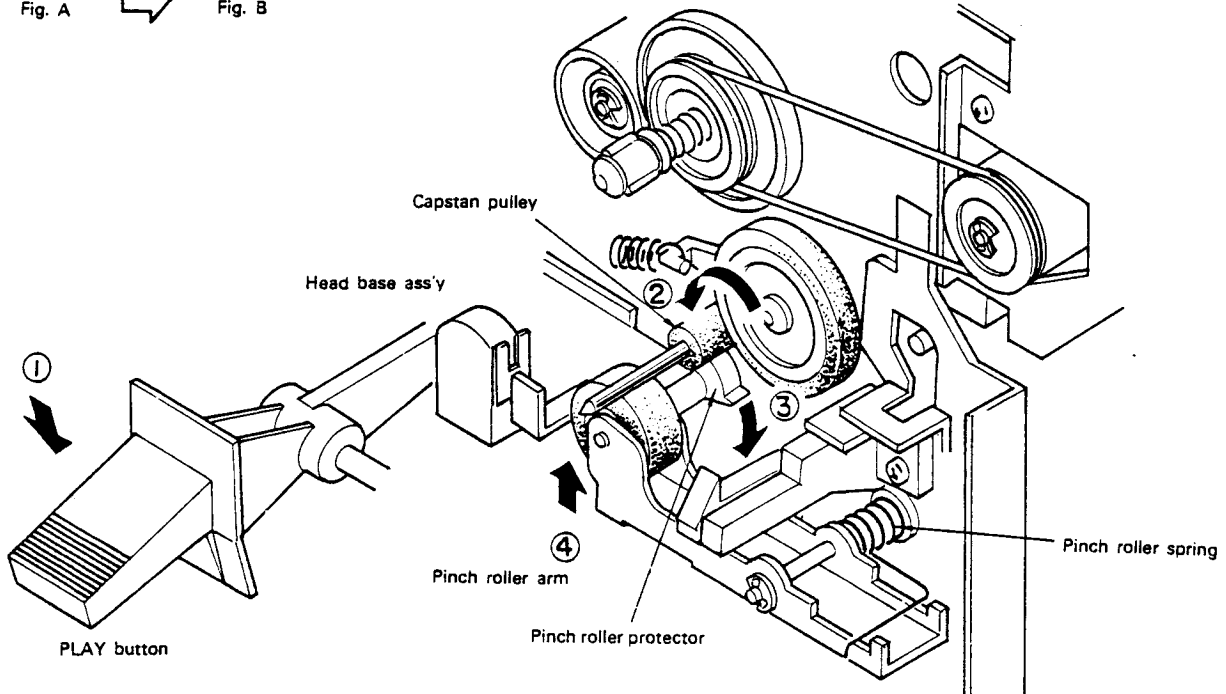

Fig. A Fig. B



RTV servis Horvat

Kešinci, 31402 Semeljci

031-856-139

031-856-637

098-788-319

rtv-servis-horvat@os.tel.hr

Croatia

Fig. 2 Timer Standby

M

Te

EXPLODED VIEW

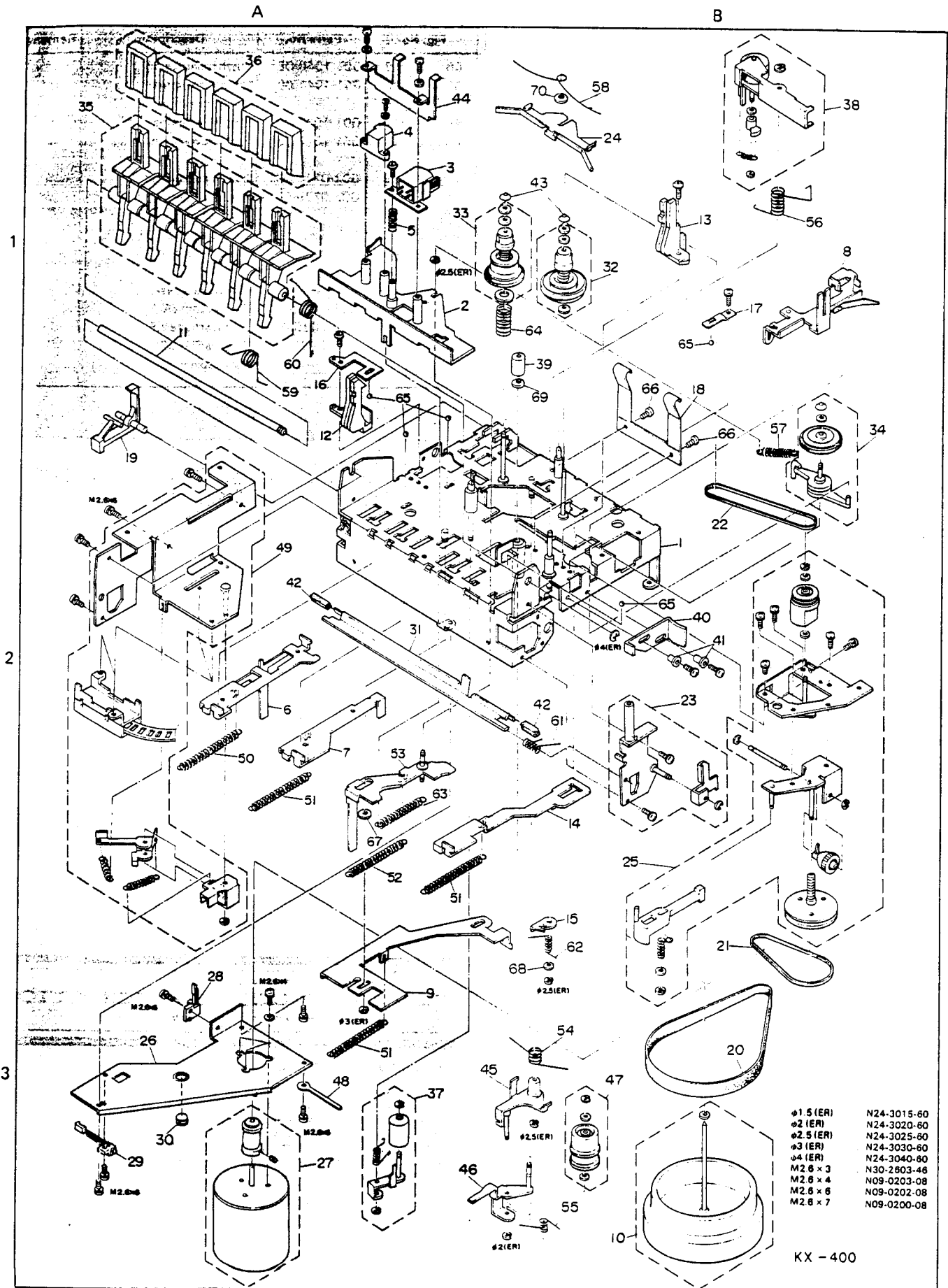

Refer to Parts List (P.T.O.)

EXPLODED VIEW PARTS LIST

☆ New part

Fig. No.	Parts No.	Description	Remarks
MECHANISM ASS'Y (D40-0500-08)			
1	2B	—	Chassis
2	1A	—	Head panel
3	1A	T34-0013-08	REC/playback head ☆
4	1A	T32-0013-08	Erase head ☆
5	1A	—	REC/play head spring
6	2A	—	REC arm
7	2A	—	REW arm
8	1B	—	Pause lever ass'y
9	3A	—	Operation arm (stop)
10	3B	D01-0309-08	Flywheel ass'y ☆
11	1A	—	Push lever shaft
12	1A	—	Cassette guide (L)
13	1B	—	Cassette guide (R)
14	2B	—	FF arm
15	3B	—	Pause lock plate
16	1A	G01-1038-08	Head panel spring (L) ☆
17	1B	G01-1039-08	Head panel spring (R) ☆
18	1B	G01-1045-08	Cassette holder spring ☆
19	1A	D10-0928-08	REC sensor ☆
20	3B	D16-0231-08	Flat belt ☆
21	3B	D16-0233-08	Square belt ☆
22	2B	D16-0234-08	Square belt ☆
23	2B	—	Lock plate holder ass'y
24	1B	—	Brake arm
25	1B	D40-0498-08	Shut off mechanism ass'y ☆
26	3A	—	Rear chassis
27	3A	T42-0114-08	DC motor ass'y ☆
28	3A	S46-1321-08	Leaf switch ☆
29	3A	S46-1322-08	Lear switch ☆
30	3A	—	Adjusting screw
31	2A	—	Lock plate
32	1B	D03-0018-08	Reel disk ass'y (A) ☆
33	1B	D03-0019-08	Reel disk ass'y (B) ☆
34	1B	D14-0232-08	Clutch ass'y ☆
35	1A	D10-0919-08	Operation lever ☆
36	1A	K29-0904-08	Knob ☆
37	3A	D14-0231-08	Idler (B) ass'y ☆
38	1B	D10-0918-08	Pinch roller arm ass'y ☆
39	1B	D15-0530-08	Capstan pulley ☆
40	2B	—	Sensor arm
41	2B	—	Sensor arm collar
42	2A,2B	—	Rubber cushion
43	1B	—	Reel cap
44	1A	—	Head protector
45	3B	—	FR lever ass'y
46	3B	—	Idle lever ass'y
47	3B	D14-0230-08	Idler (A) ass'y ☆
48	3A	—	Lug plate
49	2A	—	Lock plate holder ass'y
50	2A	—	REC arm spring
51	2A,3A	—	REW arm spring
52	3A	—	Head panel arm spring
53	2A	—	Head panel arm ass'y
54	3B	—	FR lever spring
55	3B	—	Idle lever spring

Fig. No.	Parts No.	Description	Remarks
56	1B	G01-1040-08	Pinch roller spring ☆
57	2B	G01-1041-08	Clutch arm spring ☆
58	1B	—	Brake arm spring
59	1A	G01-1072-08	Stop lever spring ☆
60	1A	G01-1042-08	Pause lever spring ☆
61	2B	G02-0340-08	Lock plate spring ☆
62	3B	G02-0339-08	Pause lock spring ☆
63	2A	—	Head panel spring
64	1B	—	Back tension spring
65	1A,2A	—	Steel ball φ2
66	1B	—	Pan head screw
67	2A	N15-1060-46	Flat washer φ5.1
68	3B	N15-1026-46	Flat washer φ2.6
69	1B	—	Flat washer φ2.4
70	1B	—	Flat washer φ4.1

RTV servis Horvat

Kešinci, 31402 Semeljci

031-856-139

031-856-637

098-788-319

rtv-servis-horvat@os.tel.hr

Croatia

A product of
TRIO-KENWOOD CORPORATION
 6-17, 3-chome, Aobadai, Meguro-ku, Tokyo 153, Japan

KENWOOD ELECTRONICS, INC.
 1315 E. Watsoncenter Rd. Carson, California 90745, U.S.A.
 75 Seaview Drive, Secaucus, New Jersey 07094, U.S.A.
 1098 North Tower Lane Bensenville, Illinois 60106, U.S.A.
TRIO-KENWOOD ELECTRONICS, N.V.
 Leuvensesteenweg 504 B-1930 Zaventem, Belgium
TRIO-KENWOOD ELECTRONICS GmbH
 Rudolf-Braas-Str. 20, 6056 Heusenstamm, West Germany
TRIO-KENWOOD FRANCE S.A.
 5, Boulevard Ney, 75018 Paris, France
TRIO-KENWOOD SVENSKA AB
 Kemistvagen 10A, S-183 21 Taby, Sweden
TRIO-KENWOOD (AUSTRALIA) PTY. LTD.
 30 Whiting St., Artarmon, N.S.W. 2064, Australia
KENWOOD & LEE ELECTRONICS, LTD.
 Room 501, Wang Kee Building, 5th Floor, 34-37, Connaught Road, Central, Hong Kong