

KENWOOD
HI/FI STEREO COMPONENTS

SERVICE MANUAL

KX-830

NOTE:

Refer to the KX-1030 service manual as to OPERATION OF MECHANISM, DISASSEMBLY, MECHANISM ADJUSTMENT, CLEANING, LUBRICATION, CIRCUIT DESCRIPTION and TROUBLESHOOTING.



STEREO CASSETTE DECK

CONTENTS

EXTERNAL VIEW.....	3
INTERNAL VIEW.....	4
BLOCK DIAGRAM.....	5
LEVEL DIAGRAM.....	6
ADJUSTMENT.....	7
MEASUREMENT.....	12
DATA.....	14
EXPLODED VIEW.....	15
EXPLODED VIEW PARTS LIST.....	18
DESTINATIONS' PARTS LIST.....	20
PARTS LIST.....	21
PC BOARD.....	22
SCHEMATIC DIAGRAM.....	23
SPECIFICATIONS.....	24

Note 1:

The products are subject to modification in components and circuits in different countries and regions. This is because each product must be used under the best condition. This manual provides information of modification based on the standard in the U.S., for the convenience of ordering associated components and parts.

U.S.A.....	K	England.....	T
Canada.....	P	Scandinavia.....	L
PX.....	U	South Africa.....	S
Australia.....	X	Other Areas.....	M
Europe.....	W		

Note 2:

Resistors except the special ones (example: cement, metal film, etc.) are not mentioned in PARTS LIST. Resistors not mentioned mean that they are carbon ones (1/4W or 1/8W). You should give an order for the carbon resistors according to the ways described as follows:

A carbon resistor's part number is: example RD14BY2E222J

1. Kinds of the carbon resistor



RD14BY



RD14CY

2. Wattage

1/4W → 2E

1/8W → 2B

3. Resistance

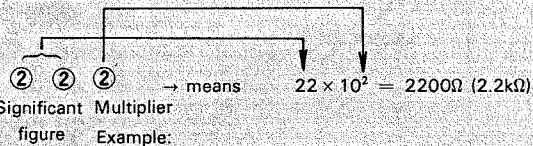

Example:

221 → 220 Ω

222 → 2.2k Ω

223 → 22k Ω

224 → 220k Ω

225 → 2.2M Ω

4. Tolerance

J = $\pm 5\%$ (Gold color)

K = $\pm 10\%$ (Silver color)

EXTERNAL VIEW

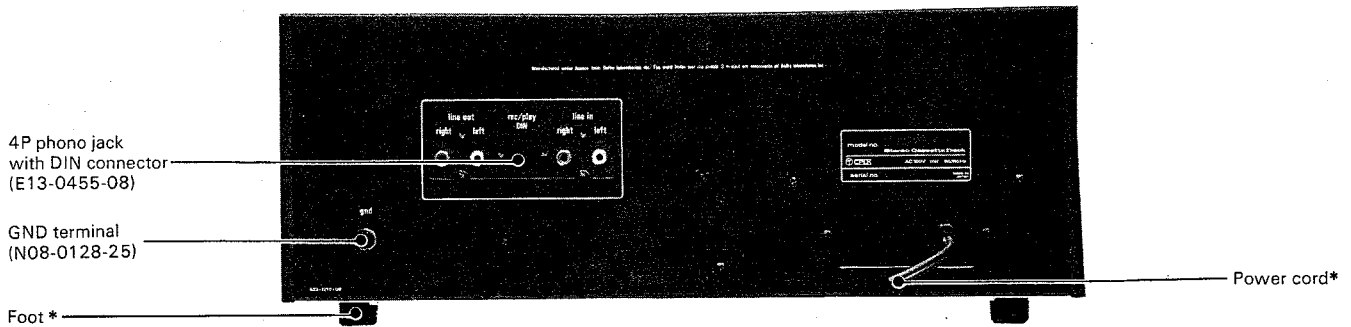
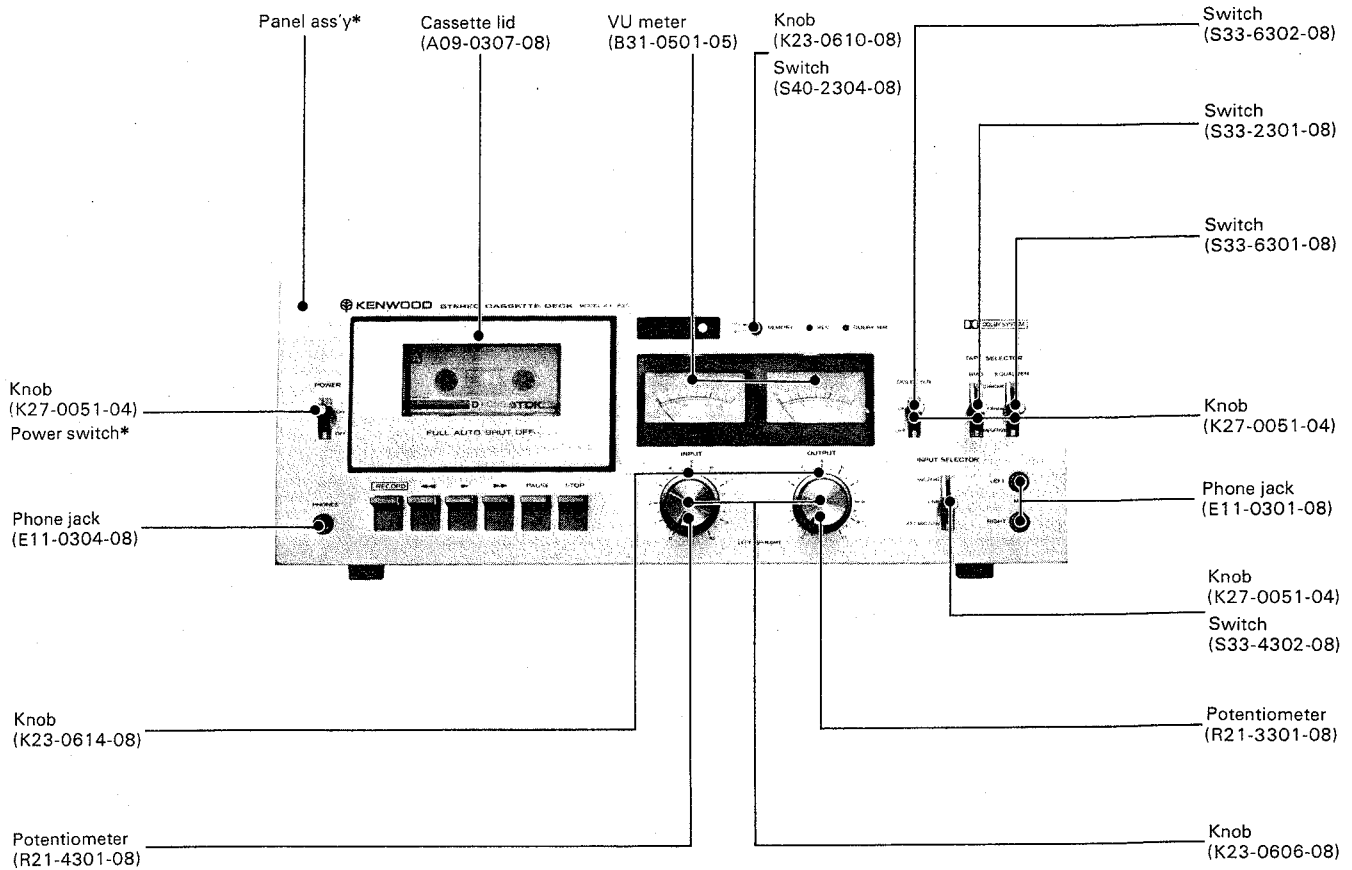

*Refer to Destinations' Parts List.

INTERNAL VIEW

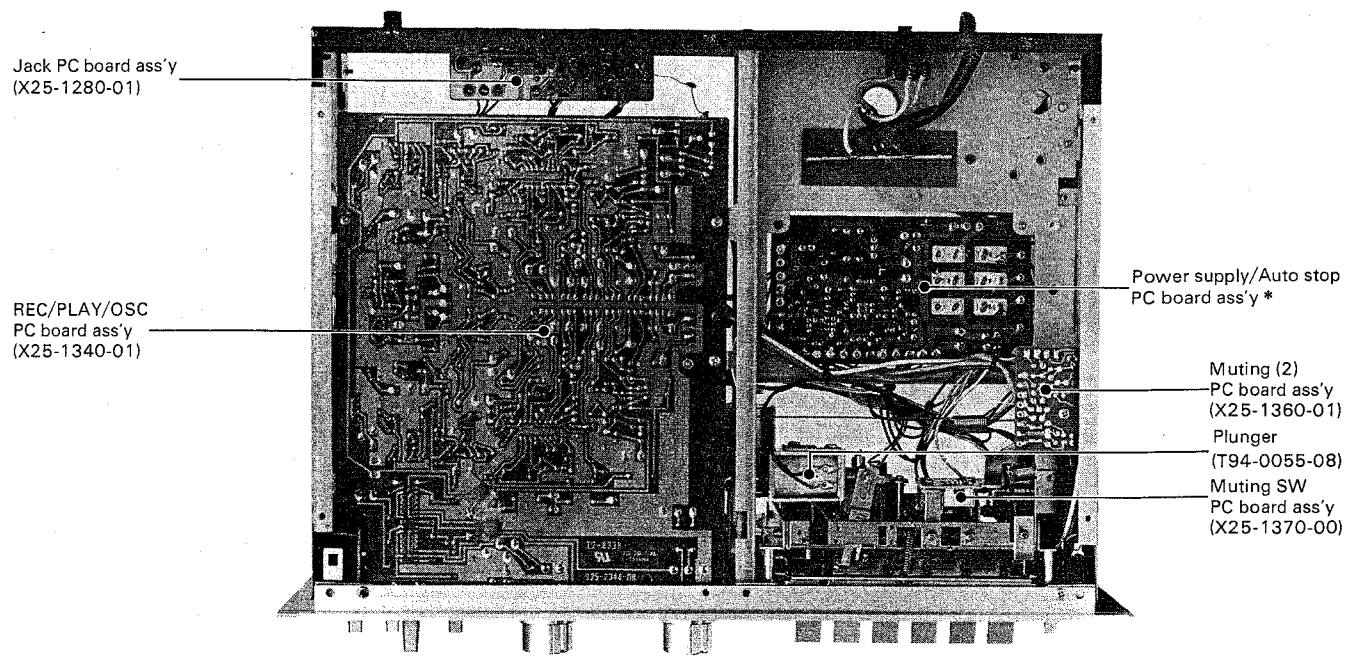
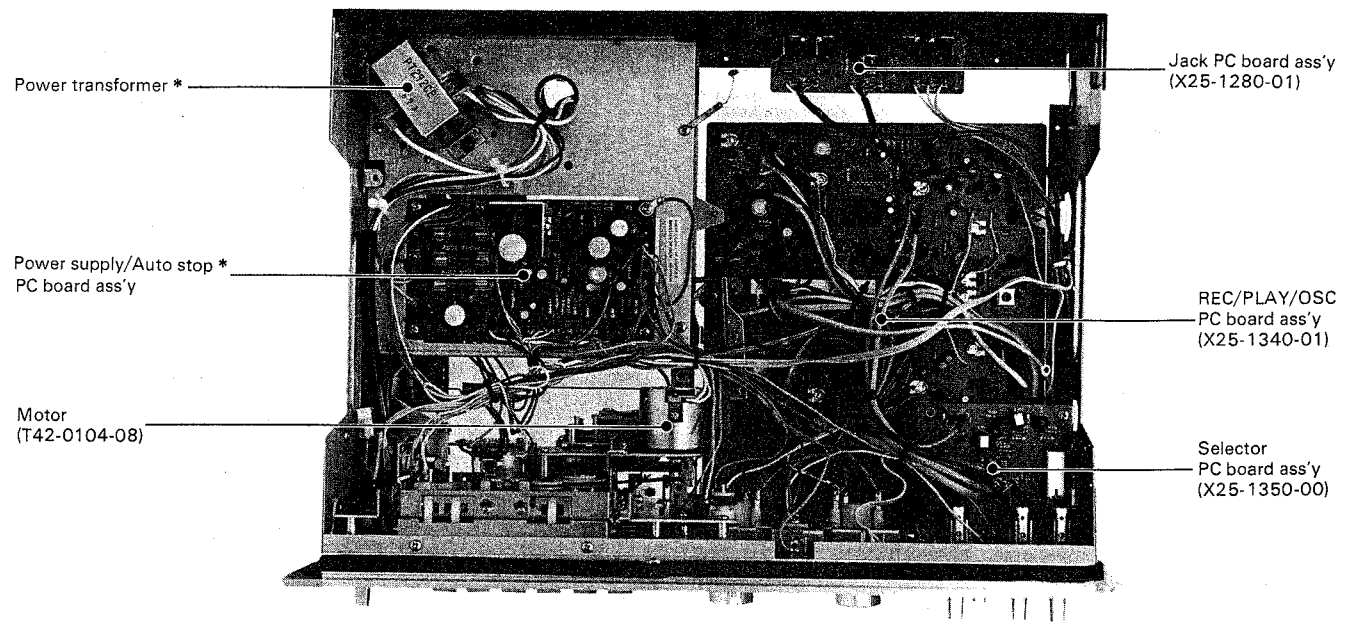

*Refer to Destinations' Parts List.

BLOCK DIAGRAM

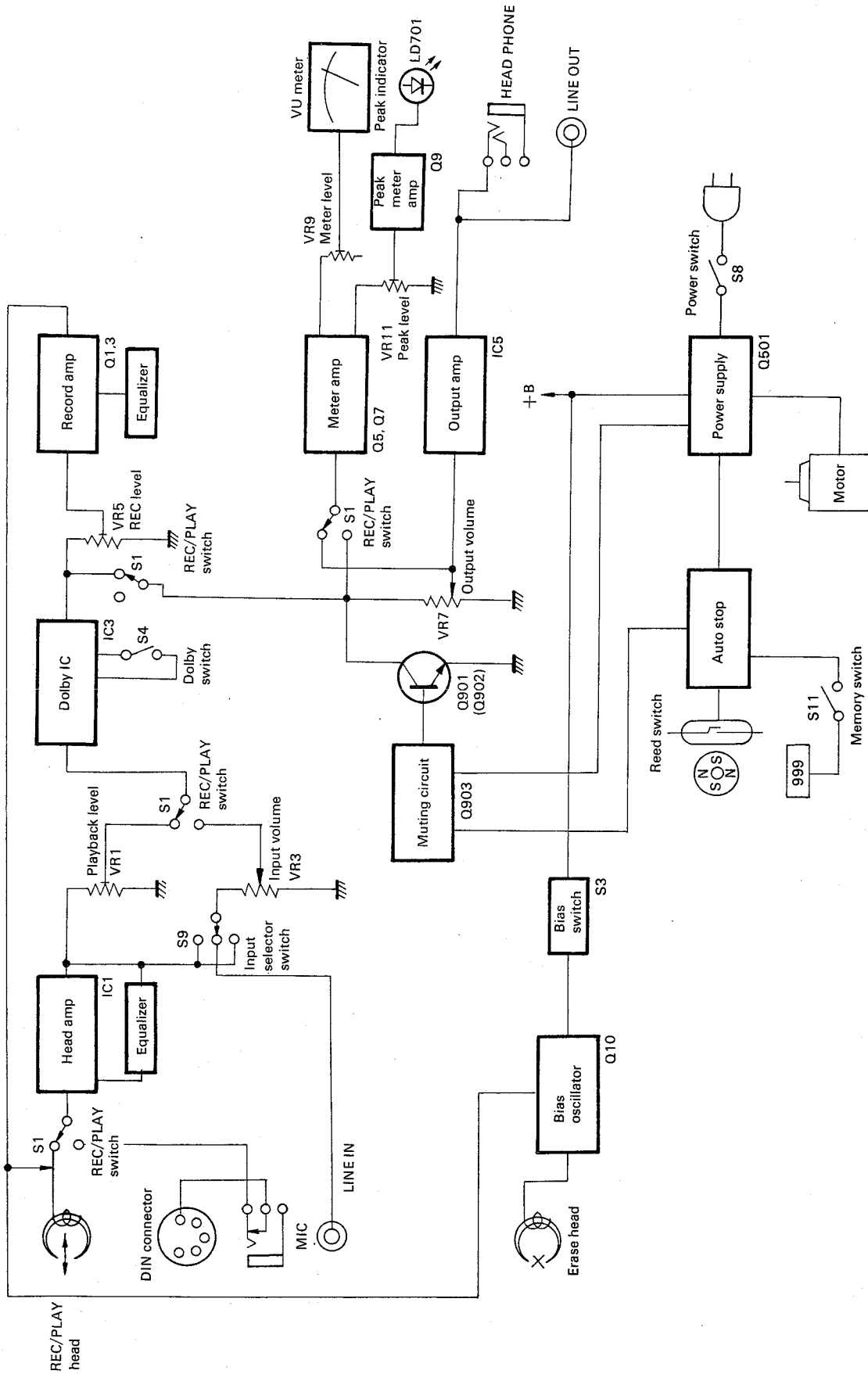

LEVEL DIAGRAM

Playback (L ch)

0 dBs = 0.775V
= 0 dBm

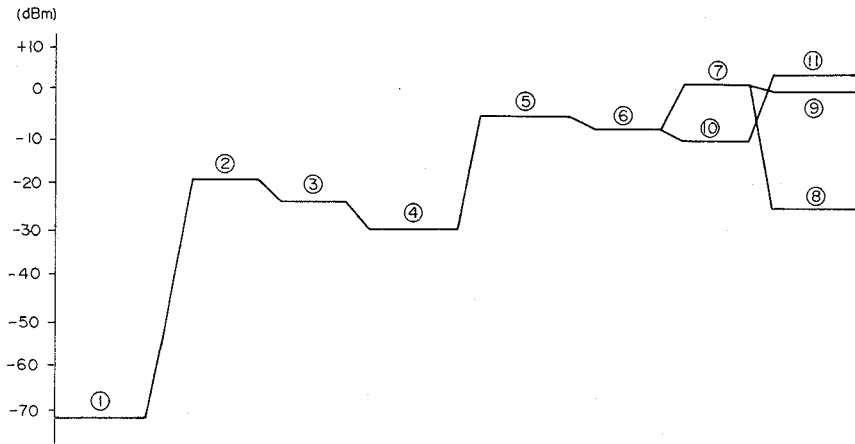
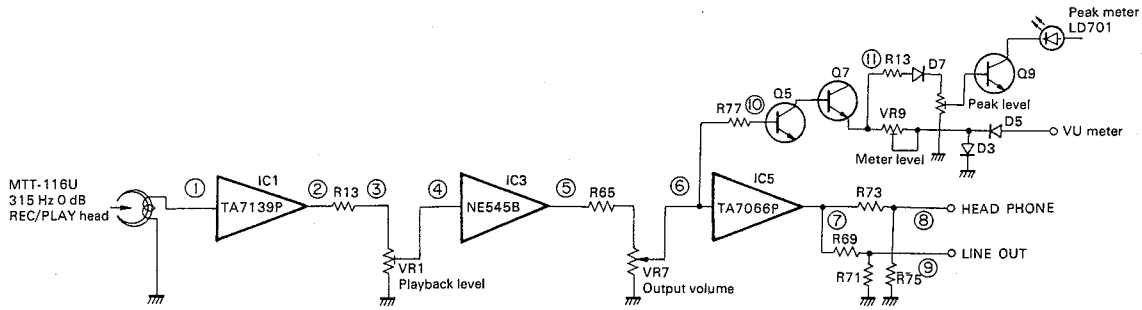

Record (R ch)

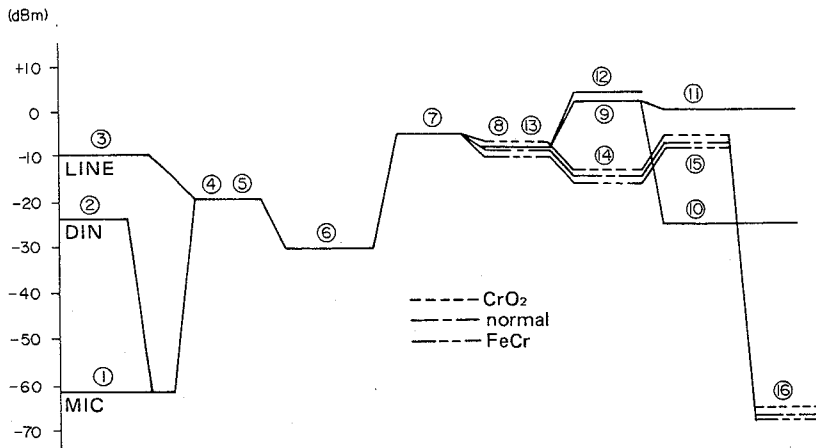
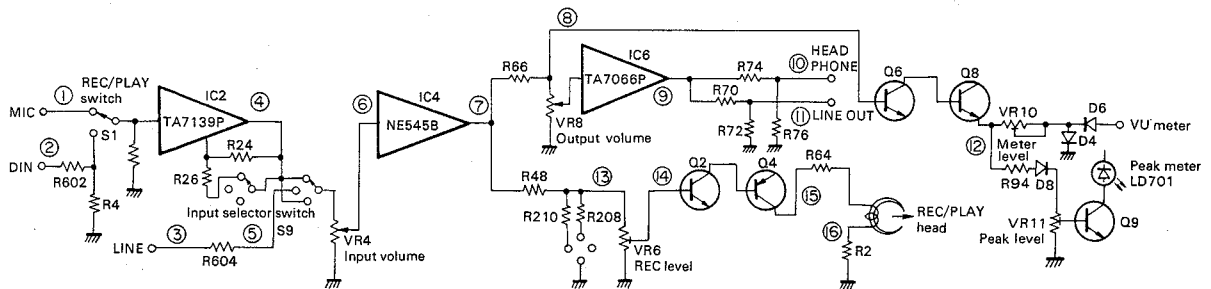

--- CrO₂
--- normal
--- FeCr

ADJUSTMENT

1. Test Instrument

- Solid state volt meter:
 - SSVM
- Audio frequency generator:
 - AG
- Oscilloscope
- Frequency counter
- Weighting filter
(ASA A characteristic with NAB curve)
- Band pass filter
(Center frequency: 100 Hz, 1 kHz,
Attenuation: 18 dB/oct. or more)
- Cassette type torque gauge
- Spring balance

2. Test Tape

- a) Test tape for recording system adjustment
NORMAL:
 TDK AC-211 (T93-0009-05) or SDC-90
 CHROME (for measurement):
 TDK AC-511 (T93-0010-05) or SAC-60
- b) Test tape for playback measurement
 TEAC MTT-111 (Tape speed, azimuth)
 TEAC MTT-116R (Frequency characteristic)
 TEAC MTT-116U (Frequency characteristic)

3. Meaning of Technical Word

- a) **Normal recording level:** A level to obtain residual magnetic flux of 160 pWb/mm on the standard recording tape, which is 4 dB below the level 315 Hz, 0 dB (250 pWb/mm) of the test tape (MTT-116R).
- b) **Normal input level:** The standard input level necessary for obtaining the normal recording level. The levels at respective input jacks are as specified below. However 80kΩ resistor should be inserted in the input of the DIN connector in series.

MIC INPUT	- 62 dBs (0VU)
ATT MIC INPUT	- 49 dBs (0VU)
LINE INPUT	- 10 dBs (0VU)
ATT DIN INPUT	- 27 dBs (0VU)
DIN INPUT	- 62 dBs (0VU)

- c) **Normal recording condition:** The state obtained by applying the 1 kHz signal to the LINE input jack at the normal input level (-10 dBs) and by adjusting the LINE volume control so that recording can be carried out at the normal recording level. (Volume position is at about 6 graduation).
- d) **Normal output level:** The standard signal level obtained at the LINE output jack when the level reference signal is reproduced from the test tape 315 Hz.

MTT-116R 315 Hz (250 pWb/mm)	Output level: 4 dBs
MTT-116U 315 Hz (160 pWb/mm)	Output level: 0 dBs

e) Standard playback

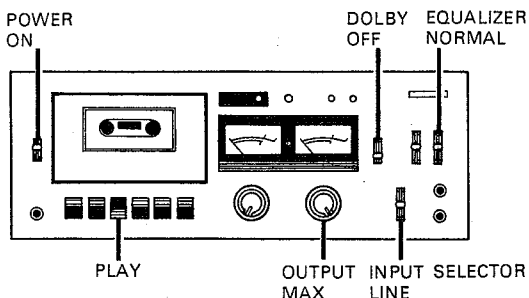

POWER	→ ON
(▶) BUTTON	→ Depress
EQUALIZER	→ NORMAL
INPUT SELECTOR	→ LINE
DOLBY N.R.	→ OFF
OUTPUT	→ MAX

f) Standard recording

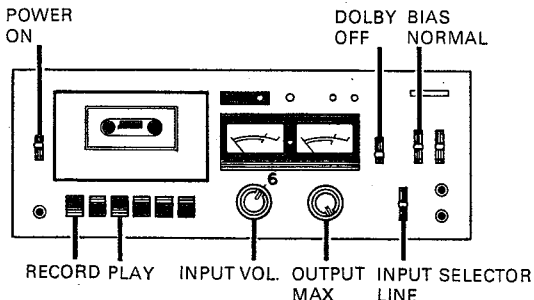

POWER	→ ON
(RECORD), (▶) BUTTON	→ Depress
BIAS	→ NORMAL
INPUT SELECTOR	→ LINE
DOLBY N.R.	→ OFF
INPUT	→ At about 6 graduation
OUTPUT	→ MAX

ADJUSTMENT

0 dBs = 0.775V
= 0 dBm

NO.	ALIGN	INPUT SIGNAL	CHECK POINTS	DECK SETTING	ADJUSTING POINTS	ADJUSTING METHOD	REMARKS
HEAD							
①	AZIMUTH OF REC/PLAY HEAD	MTT-116R 10 kHz, -10 dB	LINE OUT	Standard playback	Azimuth screw (Left side screw)	Output level (L,R): MAX.	
Note: After the alignment, fix the screws with paint. Proceed adjustments after erasing and cleaning the REC/PLAY head.							
TAPE SPEED							
②	TAPE SPEED	MTT-111	LINE OUT	Standard playback	Potentiometer in the DC motor	Frequency counter indicates 3000 Hz.	
PLAYBACK SYSTEM							
③	PLAYBACK LEVEL (DOLBY LEVEL)	MTT-116R 315 Hz, 0 dB	LINE OUT	Standard playback	VR1, 2	Output level: 4 dBs	Reference value +4 dBs ±1.5 dB
RECORDING SYSTEM (Use AC-211 (T93-0009-05))							
④	BIAS OSCILLATING FREQUENCY	—	T301 in REC/PLAY/OSC (X25-1340-01)	Recording	—	After connecting the frequency counter to the No. 127 terminal of (X25-1340-01) and check the oscillating frequency. Standard: 85 kHz ±10%	Replace the OSC coil T301 if it is deviating from the standard.
⑤a	BIAS CURRENT	—	AC voltage of the both ends R1 (R2)	Standard recording, INPUT VOL: 0	VR13, 14	Adjust to 4.5 mV (Average value)	
⑤b	BIAS CURRENT	—	AC voltage of the both ends of R1 (R2)	Standard recording, INPUT VOL: 0 BIAS → CHROME	—	Confirmation (7.0 mV: average value)	
⑥	OVERALL FREQUENCY CHARACTERISTIC	LINE IN 1 kHz, -30 dBs 10 kHz, -30 dBs	LINE OUT	Standard setting	VR13, 14	Make the outputs of 1 kHz and 10 kHz equally. The output level is about -20 dBs.	Fine adjustment
Note: 1. The bias becomes insufficient and high frequency range raise when turning VR13 or VR14 counter clockwise. 2. Since VR13 and VR14 are adjusted in BIAS CURRENT, they should be adjusted slightly in OVERALL FREQUENCY CHARACTERISTIC. 3. Repeat the alignments of "⑥" a few times.							
⑦	REC LEVEL	LINE IN 1 kHz, -10 dBs	LINE OUT	Standard recording	VR5, 6	Output level: 0 dBs	0 dBs ±1.5 dB
⑧	VU METER	LINE 1 kHz, -10 dBs	LINE OUT and VU meter	Standard recording	VR9, 10	VU meter indicates 0 VU	Reference value 0 VU ±1 VU
⑨	PEAK INDICATOR	LINE IN 1 kHz, -4 dBs Feed the signal to L and R jacks at the same time.	Peak indicator	Standard recording	VR11	Peak indicator lights.	Reference value -4 dBs ±1 dB

ADJUSTMENT

Note:

Adjust in numerical order.

① Azimuth of REC/PLAY Head

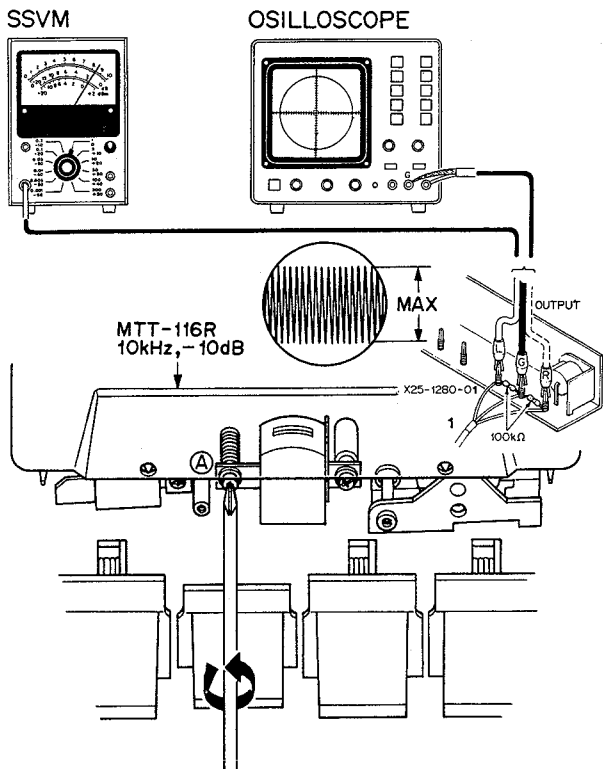

Ⓐ: For azimuth

①a Fix with paint

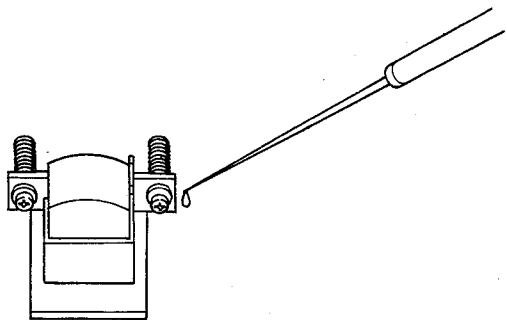

② Tape Speed

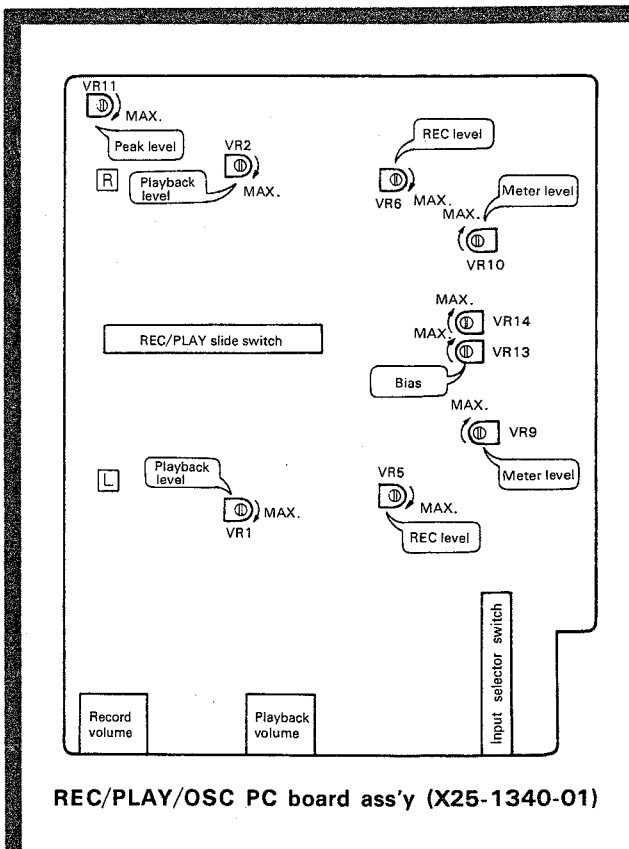
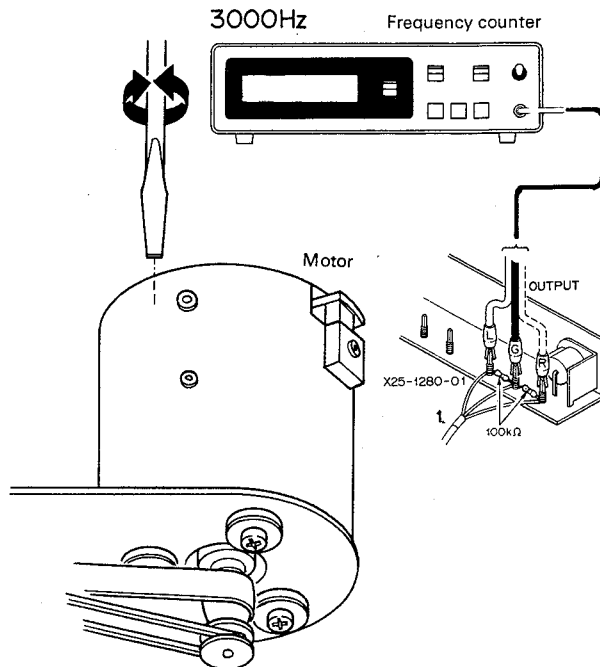

ADJUSTMENT

- ③ **Playback Level**
VR1, 2 (Standard playback)

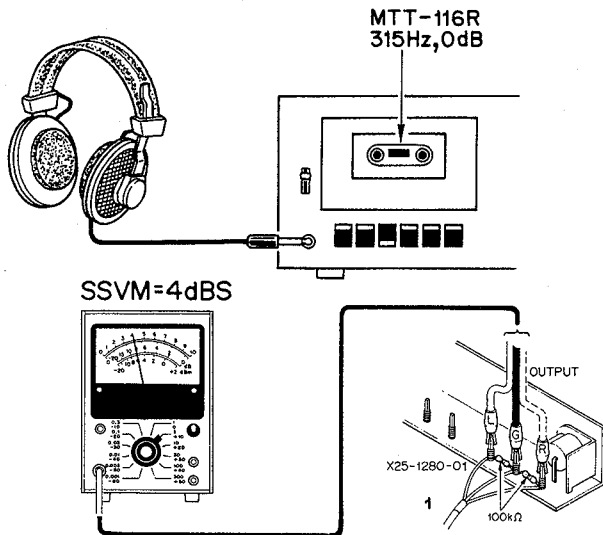

- ⑤ a **Bias Current**
VR13, 14 (Standard recording)

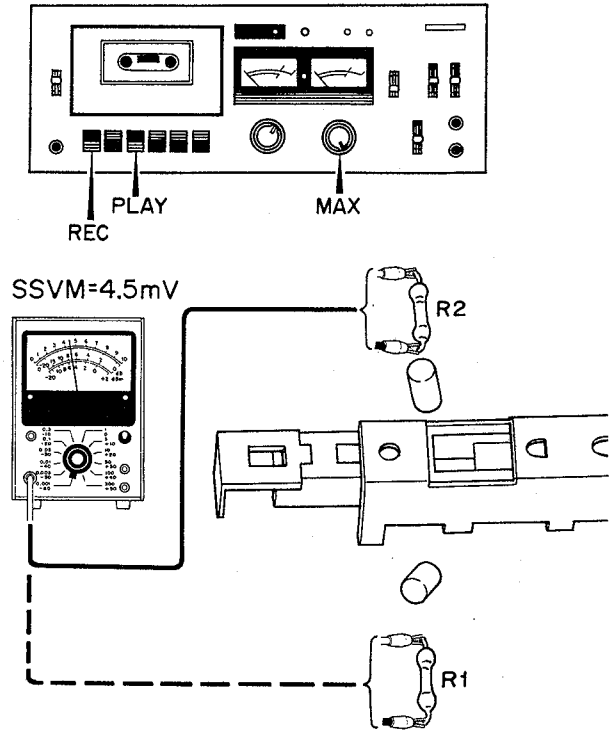

- ④ **Bias Oscillating Frequency (Recording)**

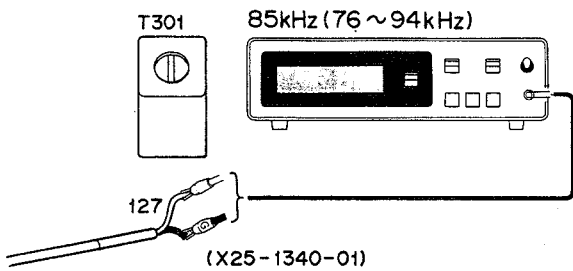

- ⑥ **Overall Frequency Characteristic**
VR13, 14 (Standard recording. Make the outputs of 1 kHz and 10 kHz equally.) (Fine adjustment)

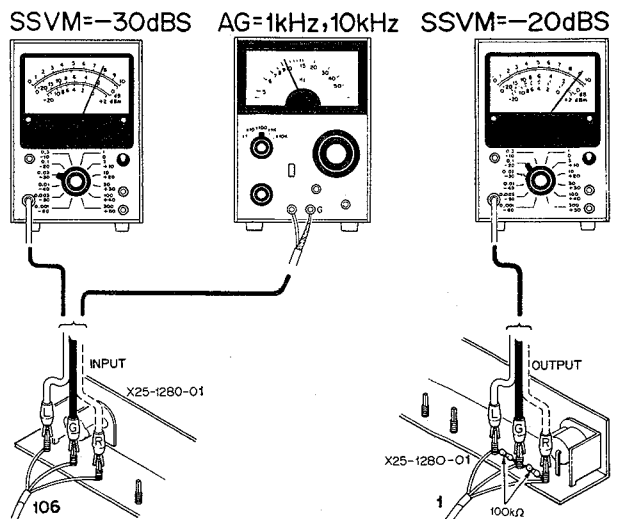

ADJUSTMENT

⑦ REC Level

VR5, 6 (Standard recording → Standard playback)

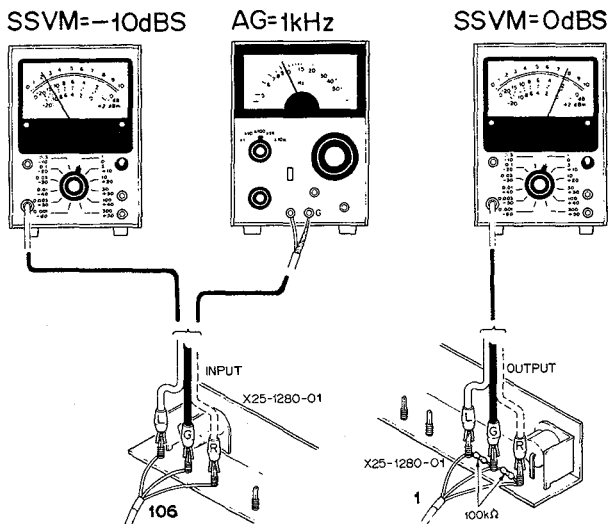

⑨ Peak Indicator

VR11 (Standard recording)

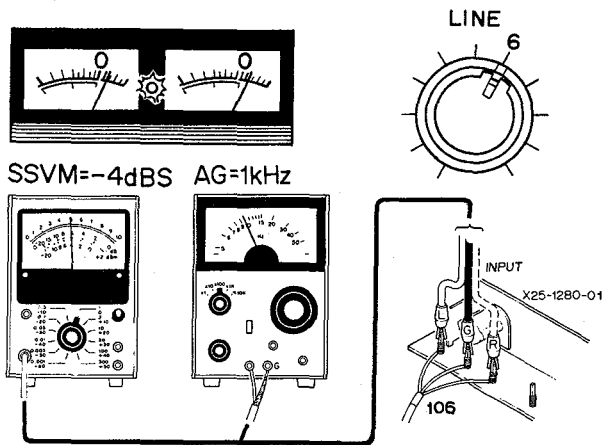

⑧ VU Meter

VR9, 10 (Standard recording)

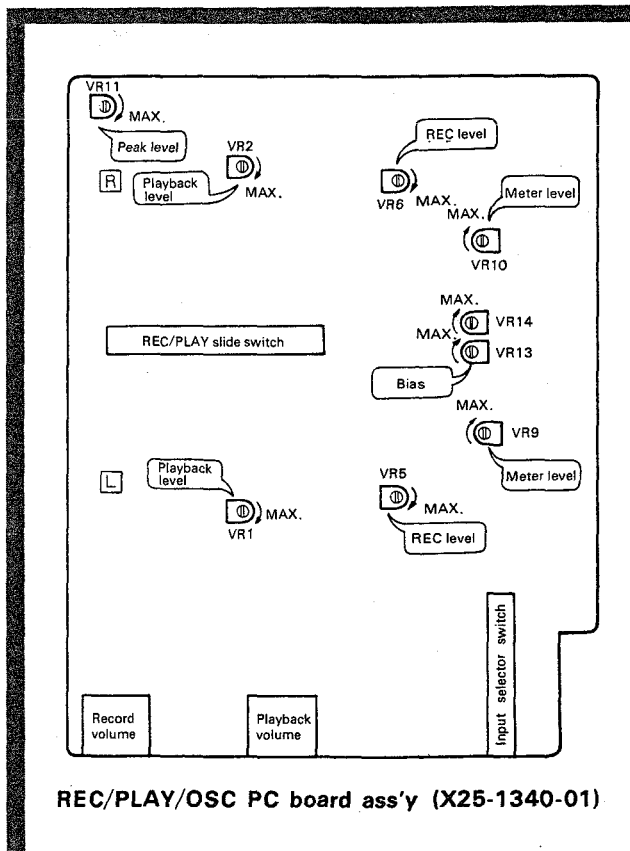
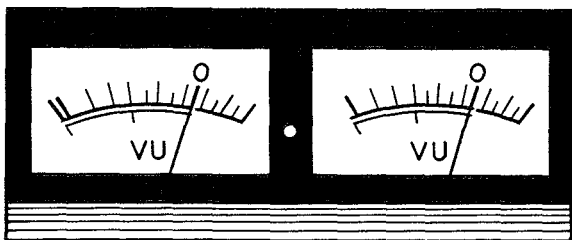
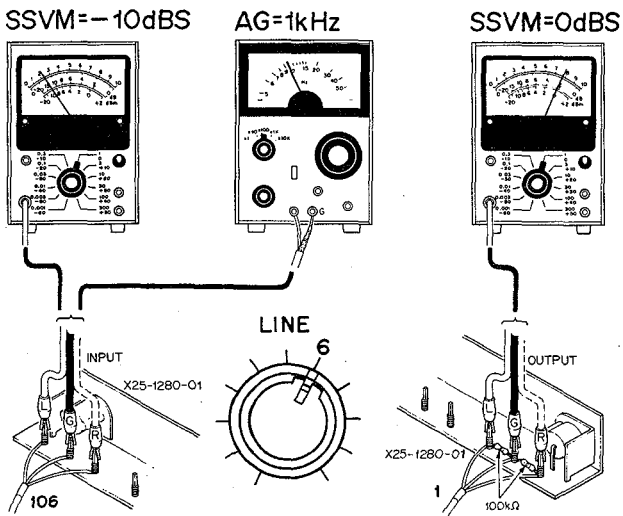

MEASUREMENT

NO.	ALIGN	INPUT SIGNAL	CHECK POINTS	SETTING	MEASUREMENT	MEASURED VALUE	REMARKS
MECHANISM SECTION							
1.	TAPE SPEED DEVIATION	MTT-111 3 kHz	LINE OUT	Playback	Error (%) = $\frac{f-3 \text{ kHz}}{3 \text{ kHz}} \times 100$	±2%	
2.	TAPE SPEED VARIATION	MTT-111 3 kHz	LINE OUT	Playback	Measure the difference between the maximum and minimum tape speed deviation.	±1%	
3.	WOW AND FLUTTER	MTT-111 3 kHz	LINE OUT	Playback	Measure at the beginning of, in the middle of, and at the end of tape running.	0.12% WRMS	
4.	TAKE-UP TORQUE	Cassette type torque gauge	—	Playback	—	35 ~ 60 g.cm	
5.	FF TORQUE	Cassette type torque gauge	—	FF	—	80 g.cm or more	
6.	REW TORQUE	Cassette type torque gauge	—	REW	—	80 g.cm or more	
7.	PINCH ROLLER PRESSURE	—	—	Playback	The ► (PLAY) button should be pressed at once. Then, pull the pinch roller with a spring balance and measure the pressure when the gap is 0.2 ~ 0.3 mm between the pinch roller and the capstan.	500 ± 50 g	
8.	TIME FOR FAST FORWARD AND REWINDING	C-60	—	FF/REW	Measure the winding time necessary for FF and REW operation respectively.	100 sec. or less	
9.	TAPE COUNTER INDICATION	C-120	—	FF/REW PLAY/REC	Read out the counter indication from the beginning to the end of the tape, in FF, REW, PLAY and REC setting. (Prior to starting the tape, press the reset button of the counter to clear the figure [000].)	940 ±50 count	
10.	TIME FOR AUTO-STOP OPERATION	—	—	FF/REW PLAY/REC	Measure the time from the moment the tape stops running until the auto-stopper functions.	3 ± ₁ ² sec.	

TEST TAPE SPECIFICATION

MTT-116R	Frequency	1590 μs and 120 μs	40 Hz ~ 10 kHz 0 dB = 250 pWb/mm	
MTT-116U	Frequency	3180 μs and 120 μs	31.5 Hz ~ 14 kHz 0 dB = 160 pWb/mm	

A normal recording level 250 pWb/mm is about 4 dB above the normal recording level 160 pWb/mm.

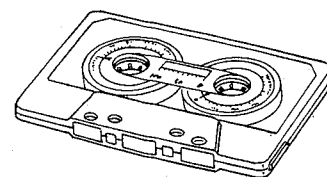

**Cassette Type Torque Gauge
(CT-100M, CT-160L)**

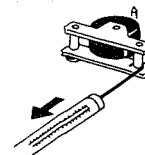

To Measure Pinch Roller Pressure

MESUREMENT

NO.	ALIGN	INPUT SIGNAL	CHECK POINTS	SETTING	MEASUREMENT	MEASURED VALUE	REMARKS
AMP SECTION							
1.	PLAYBACK LEVEL	MTT-116R 315 kHz, 0 dB	1) LINE OUT 2) DIN Connector 3) Headphone jack	Standard playback	Check the output level	4 dBs ± 1.5 dB {LINE OUT, DIN Connector} -21dBs ± 3dB (Headphones)	
2.	PLAYBACK FREQUENCY CHARACTERISTICS	MTT-116U -10 dB	LINE OUT	Standard playback	Plot output levels at respective frequencies.		See Fig. 1. (page 14)
3.	PLAYBACK SN RATIO	MTT-116U 315 Hz, 0 dB	LINE OUT	Standard playback	Check the ratio of output in the playback state vs. that in the pause state.	48dB or more (with compensation) 45dB or more (without compensation)	Weighting filter is required.
4.	PLAYBACK OUTPUT LEVEL DEVIATION	MTT-116R 6.3 kHz -10 dB	LINE OUT	Standard playback	Check deviation in the output level. For 60 sections or more.	3 dB or less	
5.	OVERALL FREQUENCY CHARACTERISTIC (1) WITH DOLBY NR OFF	-20 dB below the normal recording level input (-10 dBs) at each frequency, LINE IN	LINE OUT	Standard recording → Standard playback (DOLBY OFF, input signal -20 dB below the normal recording level input, equalizer in 3 stages)	Plot output levels at respective frequencies.		Channel balance should be made within 4 dB See Fig. 2 (page 14)
6.	OVERALL FREQUENCY CHARACTERISTIC (2) WITH DOLBY NR ON	-20 dB below the normal recording level input at each frequency, LINE IN	LINE OUT	Standard recording → Standard playback (DOLBY ON, input signal -20 dB below the normal recording level input, equalizer in 3 stages)	Plot output levels at respective frequencies.		See Fig. 3. (page 14)
7.	ERASING RATE	+6B above the normal recording level input at 1 kHz, LINE IN	LINE OUT	Recording → Playback → Erasing	Measure the output level where recording and playback have been performed and the one where the tape has been erased, using a band-pass filter. Express the resultant level difference in dB.	60 dB or more	
8.	DISTORTION	Normal recording level input 1 kHz, LINE IN	LINE OUT	Standard recording → Standard playback	Measure total harmonic distortion factor in playback output.	NORMAL 3.0 % or less CHROME 3.0 % or less	
9.	OVERALL SN RATIO	Normal recording level input at 1 kHz, LINE IN and no signal	LINE OUT	Standard recording → Standard playback	Check the ratio of playback level at 1 kHz vs. noise output level in no-signal tape.	DOLBY NR OFF: 44 dB or more (with compensation) 43 dB or more (without compensation) DOLBY NR ON: 47 dB or more (with compensation) 43 dB or more (without compensation)	Weighting filter is required. Channel balance should be made within 5 dB.
10.	CHANNEL SEPARATION	One channel: Normal recording level input at 100 Hz Another channel: no signal, LINE IN	LINE OUT	Standard recording → Standard playback	Measure the playback level in the recorded track and the crosstalk output level in the unrecorded track, using a band-pass filter. Express the resultant level difference in dB.	30 dB or more	
11.	CROWDTALK BETWEEN TRACKS	Normal recording level input at 100 Hz, LINE IN	LINE OUT	Standard recording → Standard playback	Measure the playback level in the recorded track and the crosstalk output level in the unrecorded track of the same tape section, using a band-pass filter. Express the resultant level difference in dB.	30 dB or more	

DATA

Standard:

Playback Frequency Characteristic (Fig. 1)

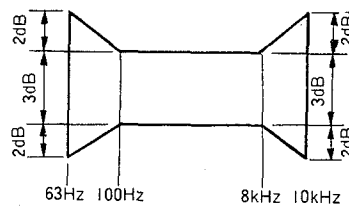

Standard:

Overall Frequency Characteristic (1) (Fig. 2)

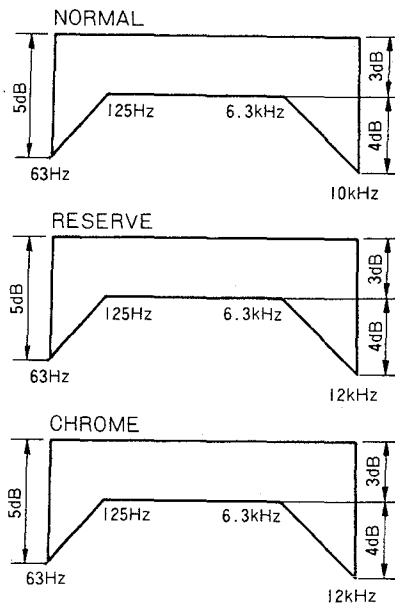

Standard:

Overall Frequency Characteristic (2) (Fig. 3)

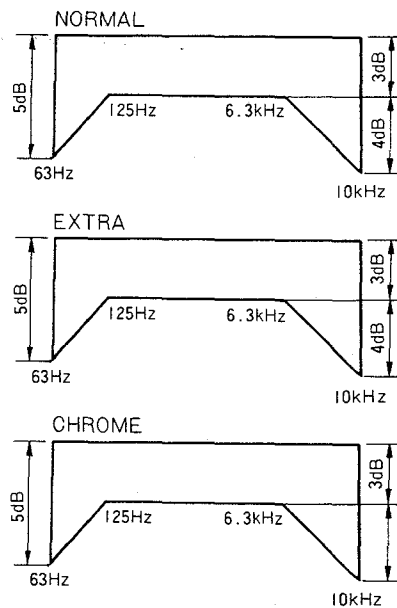

EXPLODED VIEW

A

B

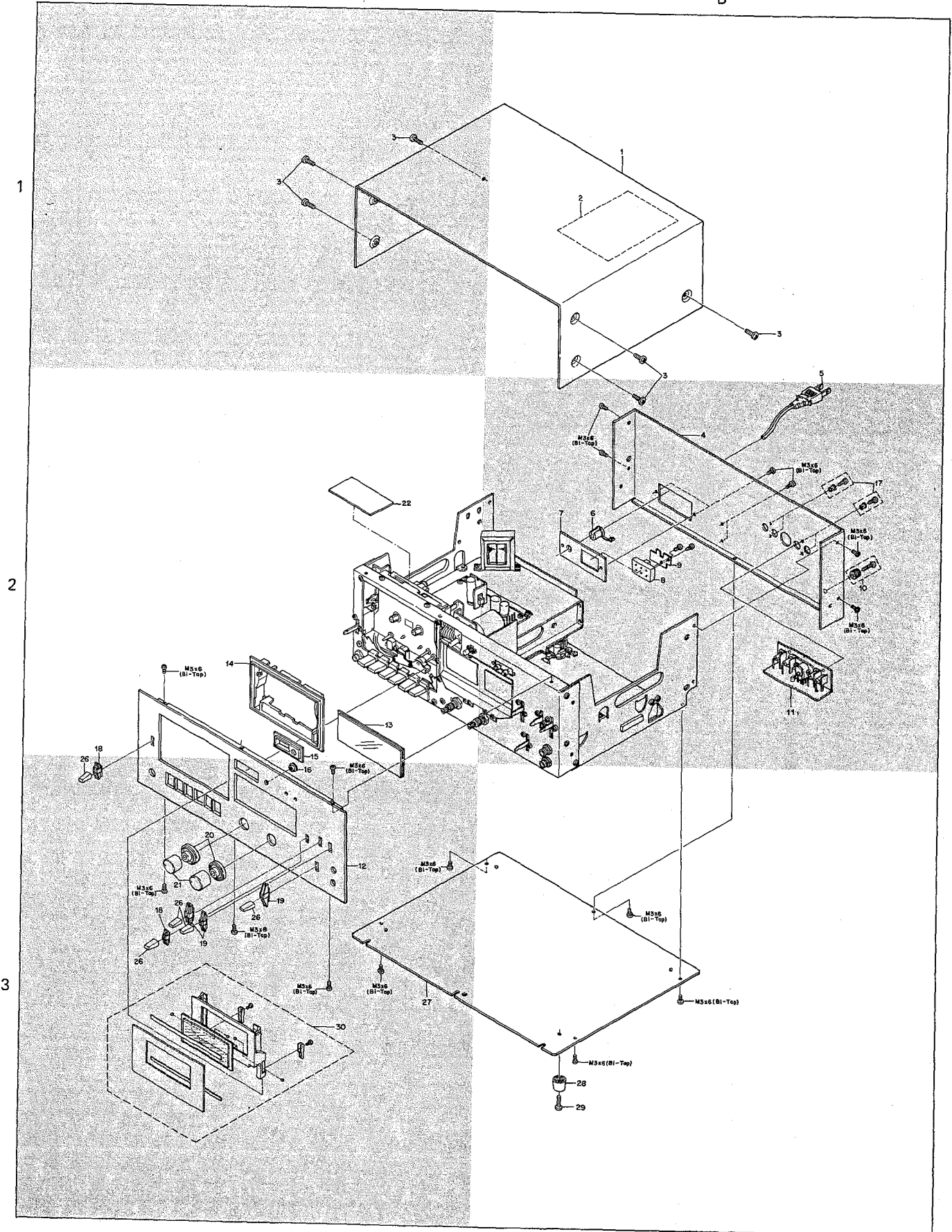

EXPLODED VIEW

A

B

4

5

6

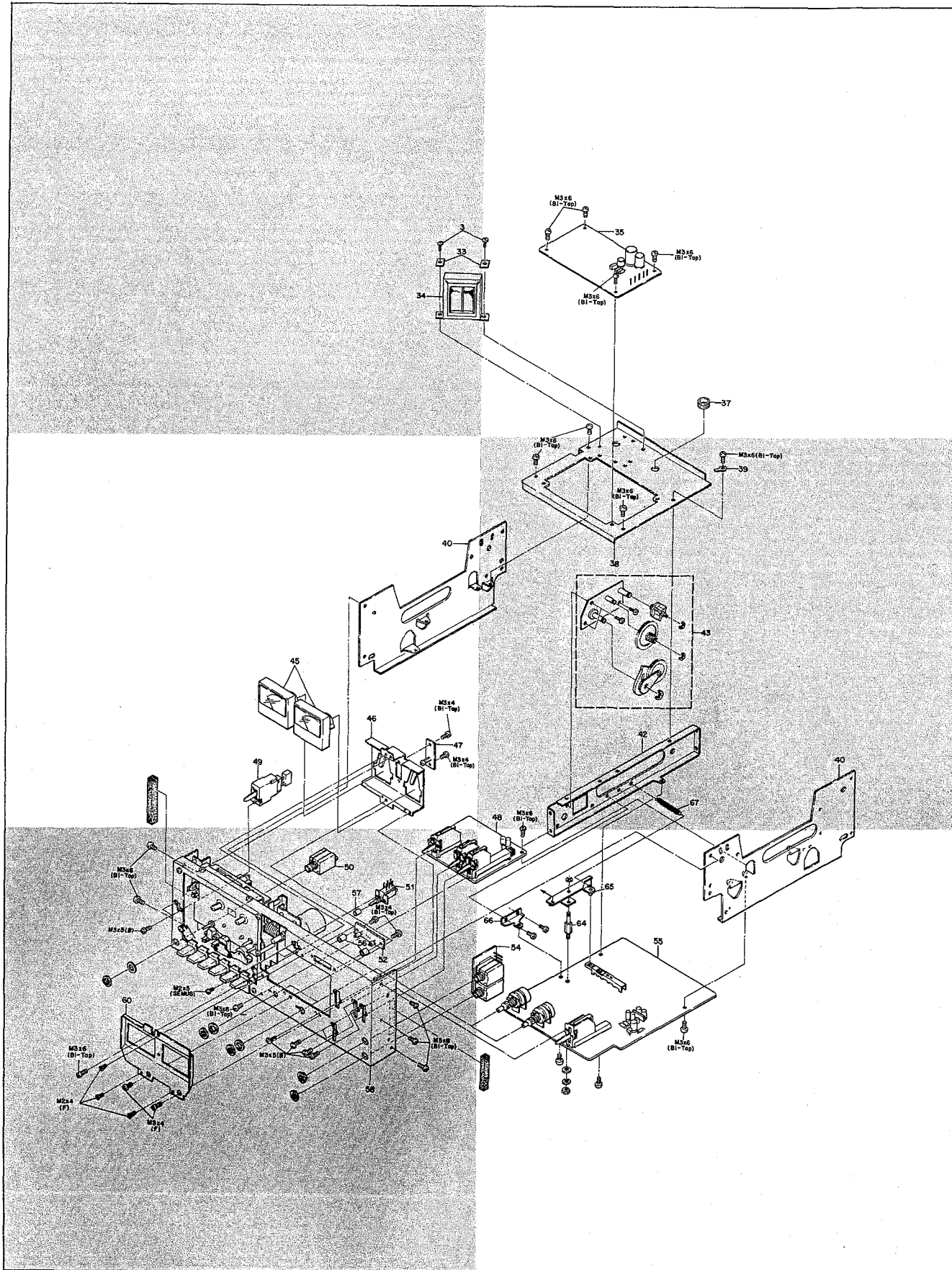

EXPLODED VIEW PARTS LIST

- : Refer to Destinations' Parts List
- ☆ : New Parts
- × : Not obtainable

Fig. No.	Parts No.	Description	Remarks
1	●	Case	1B
2	B42-1337-08	Adjustment sheet	☆ 1B
3	N09-0233-08	Binding head tap tight screw M4 × 8	1A,1B
4	A23-1207-08	Rear panel	× 2B
5	●	Power cord	1B
6	●	Power cord bushing	2B
7	●	Power cord clamp holder A	× 2B
8	●	Slide switch	2B
9	●	Switch stopper holder	2B
10	N08-0128-25	GND terminal	2B
11	X25-1280-01	JACK PC board ass'y	☆ 2B
12	●	Panel ass'y (includes the parts of 13, 14, 15, 16, 18 and 19)	☆ 3A
13	B10-0501-08	Meter front glass	2A
14	B07-0511-08	Escutcheon for mechanism chassis ass'y	2A
15	B07-0510-08	Escutcheon for tape counter	3A
16	B07-0508-08	Switch sleeve A	2A
17	N29-0202-08	Nylon rivet φ3.5 × 5.5	2B
18	B07-0205-04	Escutcheon (small)	3A
19	B07-0206-04	Escutcheon (big)	3A
20	K23-0614-08	Knob (lever switch, outside)	3A
21	K23-0606-08	Knob (lever switch, inside)	3A
22	X25-1360-01	Muting (2) PC board ass'y	☆ 2A
23	—	—	—
24	—	—	—
25	—	—	—
26	K27-0051-04	Knob (lever switch)	3A
27	A40-0518-08	Bottom plate	× 3A
28	●	Foot	3B
29	N09-0571-08	Binding head tap tight screw	3B
30	A09-0307-08	Cassette lid	☆ 3A
31	—	—	—
32	—	—	—
33	F31-0403-08	Power transformer holder	× 4A
34	●	Power transformer	4A
35	●	POWER SUPPLY/AUTO STOP PC board ass'y	4B
36	—	—	—
37	J42-0308-08	Bushing	4B
38	J21-2243-08	Top plate	× 5B
39	J19-0468-08	Lead holder	× 5B
40	J21-2241-08	Side plate	× 5A,5B
41	—	—	—
42	J21-2242-08	Middle plate	× 5B
43	D13-0201-08	Gear block ass'y	5B
44	—	—	—
45	B31-0501-05	VU meter	5A
46	J21-2244-08	VU meter holder	× 5A
47	X25-1300-00	PEAK LED PC board ass'y	5A
48	X25-1350-00	SELECTOR PC board ass'y	☆ 5B
49	●	Power switch	5A
50	E11-0304-08	Headphone jack	6A
51	S40-2304-08	Pushbutton switch for memory rewind operation	6A
52	X25-1290-00	LED PC board ass'y	6A
53	—	—	—
54	X25-1310-00	MIC JACK PC board ass'y	6B
55	X25-1340-01	REC/PLAY/OSC PC board ass'y	☆ 6B

Fig. No.	Parts No.	Description	Remarks
56	J31-0421-08	Faucet (φ6 × 4.8)	× 6A
57	K23-0610-08	Knob (MEMORY REWIND)	6A
58	J21-2263-08	Back plate II	☆ 9B
59	—	—	—
60	A21-0646-08	VU meter dress board	6A
61	D10-0501-08	Inter connecting lever ass'y	× ☆ 9A
62	J19-1250-08	Interlock lever holder ass'y	× ☆ 7A
63	G09-0215-08	REC switch interlocking spring	☆ 7A
64	D21-0637-08	REC switch operation lever shaft	× ☆ 6B
65	D10-0523-08	REC switch operation lever ass'y	× ☆ 6B
66	F31-0404-08	PC board reinforcing angle	× ☆ 6B
67	G01-0678-08	Hook lever spring	☆ 5B
68	D10-0500-08	Interconnecting lock lever ass'y	× ☆ 9B
69	G01-0677-08	Interconnecting lock lever ass'y	☆ 9A
70	T42-0104-08	Motor	7B
71	G13-0415-08	Rubber for motor	7B
72	J31-0128-08	Faucet for motor	7B
73	D21-0624-08	Stopping shaft	7B
74	N09-0208-08	Flywheel thrust adjusting screw	7B
75	J19-1224-08	Flywheel holder ass'y	7B
76	G01-0638-08	Spring for returning	7A
77	D10-0521-08	Link lever for removing pause lock	× 7A
78	D10-0477-08	Lever (1) ass'y for removing pause lock	7A
79	D15-0503-08	Motor pulley ass'y	7B
80	N70-2003-16	Set screw	7B
81	S46-1302-08	Leaf switch (PAUSE)	7A
82	T94-0055-08	Plunger	7A
83	D10-0478-08	Shut-off lever (2) ass'y	7A
84	—	—	—
85	D10-0484-08	Shut-off lever (1)	7A
86	D01-0303-08	Flywheel ass'y	7A
87	N19-0234-08	Washer φ2.5 × 0.25	7A
88	N19-0504-08	Polyethylene slider washer φ5 × φ2.5 × 0.25	7A
89	S46-1304-08	Leaf switch for motor	7A
90	—	—	—
91	G01-0294-08	Prevention spring for recording operation	8A
92	D10-0197-08	Brake operation lever	7A
93	D10-0199-08	Lock defeat plate	8A
94	G01-0632-08	Brake operation lever spring	8B
95	D10-0469-18	Pause operation lever ass'y	8B
96	G01-0636-08	Muting lever spring	8B
97	D10-0195-08	FF interlock lever ass'y	8B
98	G01-0297-08	FF interlock lever spring	7B
99	D16-0206-08	Flat belt φ62.25 × 5 × 0.4	7B
100	D10-0468-08	FR lever block ass'y	7B
101	D10-0193-08	FR lever ass'y	7A
102	D14-0204-08	Idler "A" ass'y (FW idler)	8B
103	D14-0055-08	Idler "A1" ass'y	8B
104	D14-0203-08	Idler "A2" ass'y	8B
105	N19-0529-08	Washer φ2.5 × 0.1	× 8B
106	D16-0207-08	Square belt 1* × φ56.7	8B
107	B09-0008-08	Reel cap	8A
108	N19-0249-08	Polyethylene slider washer φ1.6 × φ6 × 0.25	8A
109	D14-0205-08	Idler ass'y	8A
110	D14-0056-08	Idler "B" ass'y (REW idler)	8B

EXPLODED VIEW PARTS LIST

Fig. No.	Parts No.	Description	Remarks
111	G01-0303-08	Idler "B" lever spring	8B
112	D39-0073-08	Pause slide holding plate	× 8B
113	D10-0479-08	Lever (2) ass'y for removing pause lock	8B
114	G01-0300-08	Pause lock plate spring	8B
115	D12-0205-08	Pause lock plate	8B
116	D10-0476-08	Plate ass'y for unattended recording operation	8B
117	D10-0496-08	Tension arm ass'y "B"	8B
118	G09-0203-08	Drive roller spring	8B
119	G01-0307-08	REW lever spring "B"	8B
120	G01-0302-08	FR lever spring "D"	8B
121	D10-0201-08	REW lever "B"	8B
122	D10-0480-18	Muting lever ass'y	8B
123	D10-0483-18	FF lever	8B
124	A10-1016-08	Mechanism chassis ass'y	× ☆ 8A
125	G01-0639-08	Eject safety claw	7A
126	D21-0625-08	Cassette half holding lever shaft	8A
127	J21-2239-08	Mechanism holder "L" ass'y	× 8A
128	G09-0211-08	Cassette lock plate spring	8A
129	D12-0206-08	Cassette lock plate	8A
130	N09-0582-08	Screw with steps M3 × 5	8A
131	D19-0204-08	REC safety claw	8A
132	G09-0210-08	REC safety claw spring	8A
133	D10-0485-05	Cassette half holding lever	8A
134	G09-0209-08	Cassette half spring	8A
135	J31-0412-08	Faucet for mounting	8A
136	—	—	—
137	—	—	—
138	A13-0506-08	Angle for mounting mechanism	× 8A
139	D10-0482-08	Arm ass'y for preventing eject operation	8A
140	D10-0198-08	Brake lever	8A
141	G03-0011-08	Brake lever spring	8A
142	D03-0007-18	Reel base ass'y	8A
143	G01-0635-18	Back tension spring	8A
144	N19-0515-08	Washer $\phi 6.2 \times \phi 9.5 \times 0.15$	8A
145	B11-0303-08	Prism plate	9A
146	S46-1305-08	FF switch for BIAS selector	9A
147	—	—	—
148	T32-0004-08	Erase head	9A
149	T34-0006-08	REC/PLAY head	☆ 9A
150	A11-0318-08	Head base ass'y	☆ 8A
151	G01-0295-08	Adjusting head spring	8A
152	—	—	—
153	G01-0305-08	Pinch roller spring	9A
154	D10-0467-18	Pinch roller arm ass'y	☆ 9A
155	G01-0328-08	Head base shaft spring	9A
156	D39-0043-08	Head base shaft	9A
157	G01-0631-08	Head base spring	9A
158	N09-0205-08	Screw with toothed washer M2 × 5	9A
159	N09-0591-08	SEMUS screw M2 × 5	9A
160	G02-0065-08	Head base holding spring	9A
161	N09-0583-08	Hexagonal screw M2.6	9A
162	F01-0610-08	Head protector	× ☆ 9A
163	A29-0302-08	Cassette plate	× ☆ 9A
164	—	—	—
165	D10-0522-08	REC switch interlock lever	× ☆ 7A
166	K29-0639-08	Pushbutton block ass'y	☆ 9A

Fig. No.	Parts No.	Description	Remarks
167	D21-0623-08	Pushbutton shaft	9A
168	D10-0474-08	Pushbutton operation plate ass'y	9A
169	G01-0645-08	Pushbutton operation plate spring	9A
170	D10-0473-08	Stop pushbutton lever ass'y	9B
171	G09-0206-08	Stop pushbutton spring	9B
172	G09-0205-08	Pushbutton spring	9A
173	D10-0470-08	Pushbutton lever "A"	9A
174	D10-0471-08	Pushbutton lever "B"	9A
175	D10-0499-08	REC pushbutton lever ass'y	× ☆ 9A
176	K29-0630-08	Operational pushbutton	9A
177	D10-0475-08	Eject lever holder ass'y	9A
178	D10-0481-18	Housing arm ass'y "L"	9A
179	D10-0497-18	Housing arm ass'y "R"	9A
180	D10-0486-08	Housing arm interlock plate	9B
181	J21-2238-08	Mechanism holder "R" ass'y	× 8B
182	S59-1043-08	Reed switch	8B
183	D14-0206-08	Counter idler	9B
184	D16-0208-08	Counter belt 1□ × $\phi 39.7$	9B
185	B35-0203-08	Tape counter	9B
186	G02-0311-08	Head base holding spring "B"	9A
187	X25-1370-00	MUTING SWITCH PC board ass'y	9B
188	A15-0303-08	Frame for switch	9B
189	N09-0584-08	Flat head screw	9A
190	—	—	—
191	G01-0637-08	Housing arm spring	9B
192	F14-0106-08	Lamp tube D	8B
193	B30-0507-08	Pilot lamp 12V 60 mA	8B

Fig. No.	Parts No.
M2 × 8	N30-2008-46
M3 × 8	N30-3008-46
M3 × 4 (Bi-Tap)	N89-3004-46
M3 × 6 (Bi-Tap)	N89-3006-46
M2.6 × 4 (SEMUS)	N09-0199-08
M2.6 × 6 (SEMUS)	N09-0202-08
M2.6 × 7 (SEMUS)	N09-0200-08
M2.6 × 8 (SEMUS)	N09-0203-08
M2.6 × 15 (SEMUS)	N09-0201-08
M2 × 4 (F)	N32-2004-41
M3 × 5 (B)	N35-3005-46
M3 × 14 (B)	N35-3014-46
M2.6	N10-2026-46
M3	N10-2030-46
$\phi 1.5$ (ER)	N24-3015-60
$\phi 2$ (ER)	N24-3020-60
$\phi 2.5$ (ER)	N24-3025-60
$\phi 3$ (ER)	N24-3030-60
$\phi 4$ (ER)	N24-3040-60

DESTINATIONS' PARTS LIST

☆ : New parts

Fig. No.	U.S.A. (K)	Canada (P)	PX (U)	Australia (X)	Europe (W), Scandinavia (L)	England (T)	South Africa (S)	Other Areas (M)	Description
12	A20-1922-08	A20-1922-08	A03-0526-08 A20-1922-08	A20-1922-08	A20-1922-08	A20-1923-08	A20-1922-08	A20-1922-08	Cabinet ☆ Panel ass'y ☆
	B46-0061-10	B46-0055-20	B46-0062-10			B46-0060-00			Warranty card
			B46-0063-00						Warranty card
	B50-2249-00	B50-2251-00	B50-2249-00	B50-2249-00	B50-2249-00	B50-2250-00	B50-2249-00	B50-2249-00	Instruction manual ☆
			B59-0018-00						Kenwood service stations' list
					C91-0306-05	C91-0306-05			Ceramic capacitor x 2 0.01μF ☆
9			D32-0305-08		D32-0305-05			D32-0305-08	Switch stopper holder ☆
5	E30-0181-05	E30-0181-05	E30-1317-05	E30-0185-05	E30-0567-08	E30-0587-05	040-0306-05	E30-1317-05	Power cord
F1,2	F05-8018-05	F05-8018-05	F05-8015-05	F05-8015-05	F05-8012-05	F05-8012-05	F05-8012-05	F05-8015-05	Fuse 0.8A 250V
F3	F05-1225-08	F05-1225-08	F05-1226-08	F05-1226-08	F05-1227-05	F05-1227-05	F05-1226-08	F05-1226-08	Fuse 0.8A 250V Fuse 1.25A 250V
	H01-2266-08	H01-2267-08	H01-2269-08	H01-2266-08	H01-2266-08	H01-2268-08	H01-2266-08	H01-2266-08	Carton case ☆
	H10-2226-08	H10-2226-08	H10-2227-08	H10-2226-08	H10-2226-08	H10-2226-08	H10-2226-08	H10-2226-08	Polystyrene foamed fixture x 2 ☆
								H29-0159-04	Sealed polyethylene bag
								H40-0005-04	Antiprurst paper
28	J02-0308-08	J02-0308-08	J02-0321-08	J02-0308-08	J02-0308-08	J02-0308-08	J02-0308-08	J02-0308-08	Foot x 4
7	J21-2258-08	J21-2258-08	J21-2259-08	J21-2260-08	J21-2261-08	J21-2260-08	J21-2260-08	J21-2259-08	Power cord clamp holder A
6	J41-0034-05	J41-0034-05	J41-0034-05	J41-0024-05	J41-0033-05	J41-0033-05	J41-0024-05	J41-0034-05	Power cord bushing
34	L01-6091-08	L01-6101-08	L01-6094-08	L01-6094-08	L01-6094-08	L01-6094-08	L01-6094-08	L01-6094-08	Power transformer
SK	R90-0110-08	R90-0401-08	R90-0111-08	R90-0111-08			R90-0111-08	R90-0111-08	Spark killer
8			S31-2301-05		S31-2301-05		S31-2301-05	S31-2301-05	Slide switch
49	S33-1301-08	S33-1301-08	S33-1301-08	S33-2302-08	S33-2302-08	S33-2302-08	S33-2302-08	S33-1301-08	Power switch ☆
35	X27-1280-13	X27-1280-13	X27-1280-13	X27-1280-13	X27-1280-63	X27-1280-63	X27-1280-13	X27-1280-13	POWER SUPPLY PC board ass'y

PARTS LIST

PARTS LIST

TOTAL

☆ : New parts

Ref. No.	Parts No.	Description	Re- marks
—	B42-0009-04	Passed sticker	
—	E30-0541-05	Audio cord	
—	H25-0078-08	Instruction bag	
—	W01-0301-05	Head cleaning bar	

JACK (X25-1280-01)

Ref. No.	Parts No.	Description	Re- marks
—	E13-0455-08	Phono jack (4P with DIN connector)	

LED (X25-1290-00)

Ref. No.	Parts No.	Description	Re- marks
LD801	V11-0404-05	LED GD4-207RD (Red)	
LD802	V11-7200-20	LED GD4-207GD (Green)	

PEAK LED (X25-1300-00)

Ref. No.	Parts No.	Description	Re- marks
LD701	V11-0390-05	LED GD4-203RD	
—	J31-0413-08	LED holder	

MIC JACK (X25-1310-00)

Ref. No.	Parts No.	Description	Re- marks
—	E11-0301-08	Mic jack × 2 (with switch)	

REC/PLAY/OSC (X25-1340-01)

Ref. No.	Parts No.	Description	Re- marks
CAPACITOR			
C1,2	CE04W1E101	Electrolytic 100μF 25WV	
C3,4	CE04AW1C100CC	Electrolytic 10μF 16WV	
C7,8	CQ09S1H471J	Polystyrene 470pF ±5%	
C9,10	CE04W1C100	Electrolytic 10μF 16WV	
C11,12	CC45SL1H470J	Ceramic 47pF ±5%	
C13,14	CE04W1E4R7	Electrolytic 4.7μF 25WV	
C15,16	CQ92M2D682K	Mylar 0.0068μF ±5%	
C17,18	CE04W1C100	Electrolytic 10μF 16WV	
C19,20	CQ92M1H822J	Mylar 0.0082μF ±5%	
C21,22	CE04AW1H1R0CC	Electrolytic 1μF 50WV	
C23,24	CE04W1C100	Electrolytic 10μF 16WV	

Ref. No.	Parts No.	Description	Re- marks
C25,26	CQ92M1H472J	Mylar 0.0047μF ±5%	
C27,28	CQ92M1H273J	Mylar 0.027μF ±5%	
C29,30	CE04W1C100	Electrolytic 10μF 16WV	
C31,32	CQ92M1H473J	Mylar 0.047μF ±5%	
C33,34	CQ92M1H562J	Mylar 0.0056μF ±5%	
C35~38	CE04W1C100	Electrolytic 10μF 16WV	
C39,40	CE04W1H010	Electrolytic 1μF 50WV	
C41,42	CE04W1H0R1M	Electrolytic 0.1μF 50WV	
C43,44	CE04W1HR33M	Electrolytic 0.33μF 50WV	
C45,46	CE04W1C221	Electrolytic 220μF 16WV	
C47,48	CE04AW1C100CC	Electrolytic 10μF 16WV	
C49,50	CC45SL1H470J	Ceramic 47pF ±5%	
C51,52	CQ92M1H154J	Mylar 0.15μF ±5%	
C53,54	CE04AW1C100CC	Electrolytic 10μF 16WV	
C55,56	CQ09S1H821J	Polystyrene 820pF ±5%	
C57,58	CQ09S1H151J	Polystyrene 150pF ±5%	
C59,60	CE04W1E4R7	Electrolytic 4.7μF 25WV	
C61,62	CQ92M1H102J	Mylar 0.001μF ±5%	
C63~66	CE04W1C100	Electrolytic 10μF 16WV	
C67,68	CE04AW1E100CC	Electrolytic 10μF 25WV	
C69,70	CE04W1C330	Electrolytic 33μF 16WV	
C71,72	CE04W1H010	Electrolytic 1μF 50WV	
C73,74	CE04W1C100	Electrolytic 10μF 16WV	
C75,76	CE04W1H2R2	Electrolytic 2.2μF 50WV	
C77,78	CE04W1H3R3	Electrolytic 3.3μF 50WV	
C79,80	CE04W1E4R7	Electrolytic 4.7μF 25WV	
C81,82	CM93D1H680J	Mica 68pF ±5%	
C301	CE04W1E4R7	Electrolytic 4.7μF 25WV	
C302	CQ92M1H103J	Mylar 0.01μF ±5%	
C303	CQ92M1H682J	Mylar 0.0068μF ±5%	
C304	CQ92M1H392J	Mylar 0.0039μF ±5%	
RESISTOR			
R1,2	RN14BK2E10R0F	Metal film 10Ω ±1% 1/4W	
R5,6	RN14BK2E1002F	Metal film 100kΩ ±1% 1/4W	
R19,20	RN14BK2E1801F	Metal film 18kΩ ±1% 1/4W	
R55,56	RN14BK2E2701F	Metal film 27kΩ ±1% 1/4W	
R57,58,63,64	RN14BK2E1001F	Metal film 10kΩ ±1% 1/4W	
SEMICONDUCTOR			
Q1,2	V03-1327-10	Transistor 2SC1327(S), (T)	
Q3,4	V01-0220-05	Transistor 2SA721(R), (S)	
Q5~9	V03-9991-05	Transistor 2SC828(R), (S)	
	V03-0339-05	or 2SC536(F), (G)	
Q10	V03-1214-10	Transistor 2SC1214(C)	
IC1,2	V30-0262-10	IC TA7139P	
IC3,4	V30-0139-05	IC NE545B	
IC5,6	V30-0154-05	IC TA7066P	
D1~8	V11-9990-05	Diode 1S188AM	
	V11-0051-05	or 1N60	
	V11-0197-05	or OA90	
POTENTIOMETER			
VR1,2	R12-3043-08	Trimming 20kΩ (B) PB LEVEL	
VR3,4	R21-4301-08	50kΩ (A) INPUT VOL	
VR5,6	R12-3043-08	Trimming 20kΩ (B) REC LEVEL	
VR7,8	R21-3301-08	10kΩ (A) OUTPUT VOL	
VR9~11	R12-3044-08	Trimming 10kΩ (B) METER LEVEL	
VR13,14	R12-5027-08	Trimming 100kΩ (B) BIAS LEVEL	
COIL/INDUCTOR/FILTER			
T301	L32-0502-08	Bias OSC coil	☆

Ref. No.	Parts No.	Description	Re- marks
L1,2	L39-0077-08	Inductor 22mH (223K)	
F1,2	L79-0302-08	Low pass filter	
SWITCH			
S1	S31-0303-18	REC/PLAY switch	☆
S9	S33-4302-08	Lever switch INPUT SELECTOR	

SELECTOR (X25-1350-00)

Ref. No.	Parts No.	Description	Re- marks
CAPACITOR			
C201,202	CQ92M1H123J	Mylar 0.012μF ±5%	
C203,204	CQ92M1H822J	Mylar 0.0082μF ±5%	
C205,206	CQ92M1H273J	Mylar 0.027μF ±5%	
RESISTOR			
R216	RS14AB2H561J	Metal film 560Ω ±5% 1/2W	
SWITCH			
S2	S33-6301-08	Lever switch TAPE SEL	
S3	S33-2301-08	Lever switch BIAS	
S4	S33-6304-08	Lever switch DOLBY	
INDUCTOR			
L201,202	L39-0302-08	8.2mH (K)	

MUTING (2) (X25-1360-01)

Ref. No.	Parts No.	Description	Re- marks
CAPACITOR			
C903	CE04W1H010	Metal film 1μF 50WV	
SEMICONDUCTOR			
Q901,902	V03-9991-05	Transistor 2SC828(R)	
	V03-0339-05	or 2SC536(F)	
C903	V01-0163-05	Transistor 2SA564(R)	
D901,902	V11-0419-05	Diode 1N4002	
D903,904	V11-0420-05	Diode TD9600-16-1	
		or 1S2473	
		or WG-713	
D905	V11-9990-05	Diode 1S188AM	☆
	V11-0051-05	or 1N60	
	V11-0197-05	or OA90	

MUTING (X25-1370-00)

Ref. No.	Parts No.	Description	Re- marks
S7	S31-4302-08	Slide switch	

POWER SUPPLY/AUTO STOP (X27-1280-)

Ref. No.	Parts No.	Description	Re- marks
CAPACITOR			
C501	CE04W1V222	Electrolytic 2200μF 35WV	
C502	CE04W1E471	Electrolytic 470μF 25WV	
C503	CE04W1E221	Electrolytic 220μF 25WV	
C504	CE04W1E102	Electrolytic 1000μF 25WV	
C505	CE04W1C221M	Electrolytic 220μF 16WV	
C506	CE04W1C330	Electrolytic 33μF 16WV	
C507	CQ92M1H102M	Mylar 0.001μF ±20%	
C508	CE04W1C220	Electrolytic 22μF 16WV	
C509	CE04W1C470	Electrolytic 47μF 16WV	
C510,511	CE04W1H010	Electrolytic 1μF 50WV	
C512,513	CE04W1C100	Electrolytic 10μF 16WV	
RESISTOR			
R501	RS14AB3A821J	Metal film 820Ω ±5% 1W	
R502	RS14AB2H471J	Metal film 470Ω ±5% 1/2W	
SEMICONDUCTOR			
Q501	V03-1226-10	Transistor 2SC1226(Q) or (R)	
Q502,503	V03-9991-05	Transistor 2SC828(R)	
	V03-0339-05	or 2SC536(F)	
Q504	V01-0163-05	Transistor 2SA564(R)	
Q505~507	V03-9991-05	Transistor 2SC828(R)	
	V03-0339-05	or 2SC536(F)	
Q508	V01-0164-05	Transistor 2SA699(O) or (R)	
D501,502	V11-2400-20	Diode bridge W02	
D503	V11-0419-05	Diode 1N4002	
D504~507	V11-0420-05	Diode TD9600-16-1	
		or 1S2473	
		or WG-713	
ZD501	V11-4100-10	Zener diode WZ-182	
MISCELLANEOUS			
—	J13-0047-08	Fuse holder (X27-1280-13) × 6 (for M,U,K,P,S,X)	
—	J13-0048-08	Fuse holder (X27-1280-63) × 6 (for W,T,L)	

KX-830 KX-830

PC BOARD

POWER SUPPLY (X27-1280-13)

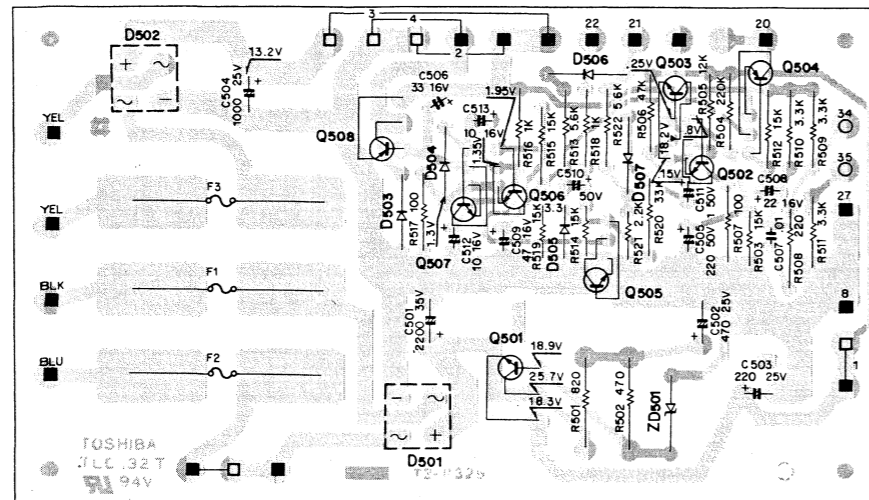

Q501: 2SC1226(Q), (R), Q502,503: 2SC828(R) or 2SC536(F), Q504: 2SA564(R), Q505~507: 2SC828(R) or 2SC536(F), Q508: 2SA699(Q), (R), D501, 502: W02, D503: 1N4002, D504,505: WG713 or 1S2473 or TD9600-16-1, ZD501: WZ182

REC/PLAY/OSC (X25-1340-01)

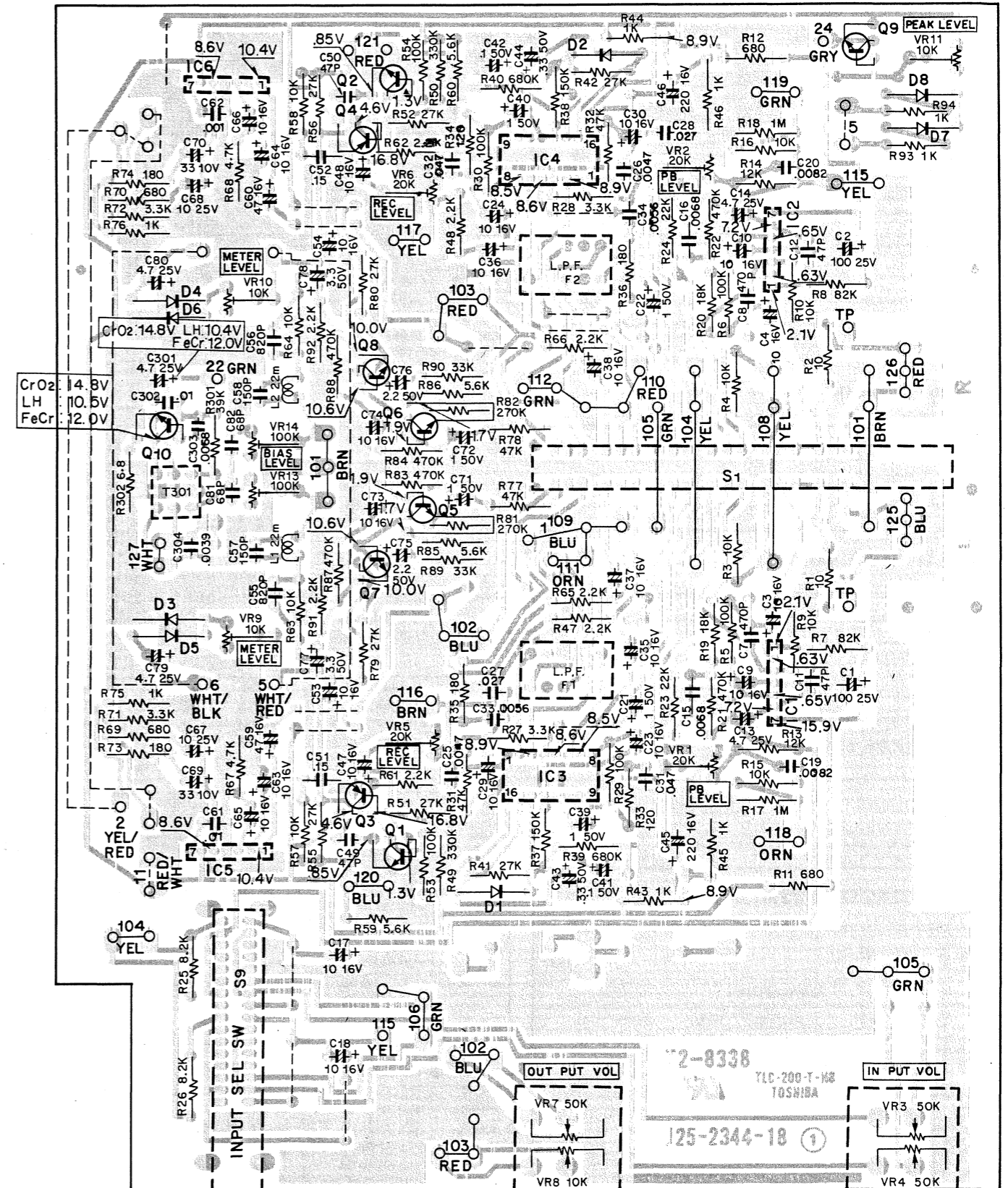

Q1,2: 2SC1327(S) or (T), Q3,4: 2SA721(R) or (S), Q5 ~ 9: 2SC828(R) or (S) or 2SC536(F) or (G), Q10: 2SC1214(C)
IC1,2: TA7139P, IC3,4: NE545B, IC5,6: TA7066P, D1 ~ 8: 1S188AM or OA90 or 1N60

SELECTOR (X25-1350-00)

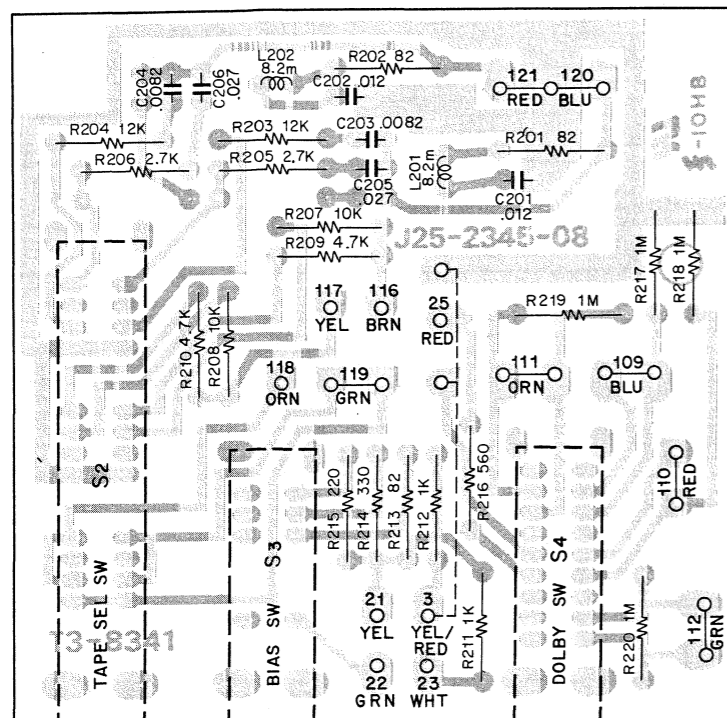

MUTING (2) (X25-1360-01)

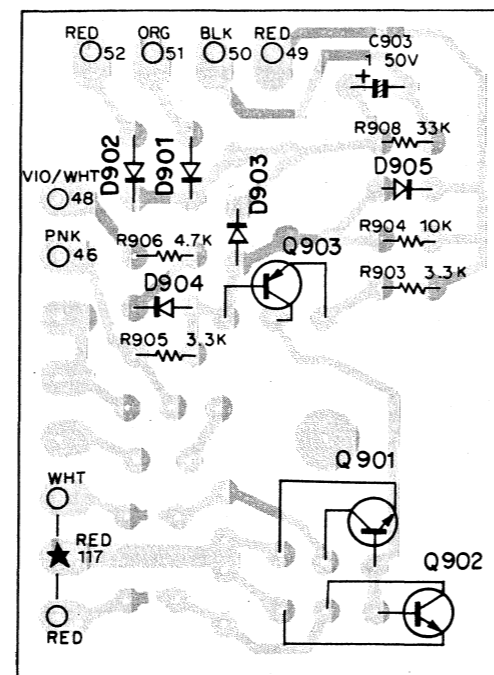

Q901, 902: 2SC828(R) or 2SC536(F)
Q903: 2SA564(R), D901, 902: 1N4002,
D903, 904: WG713 or 1S2473 or TD9600-16-1
D905: 1S188AM or 1N60 or OA90

SCHEMATIC DIAGRAM

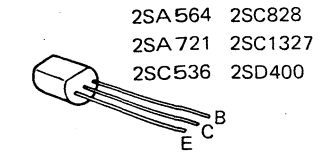

2SA564 2SC828
2SA721 2SC1327
2SC536 2SD400

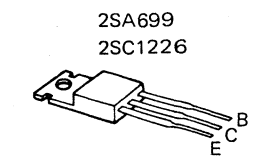

2SA699
2SC1226

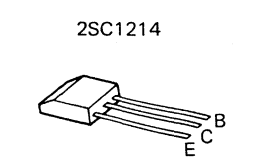

2SC1214

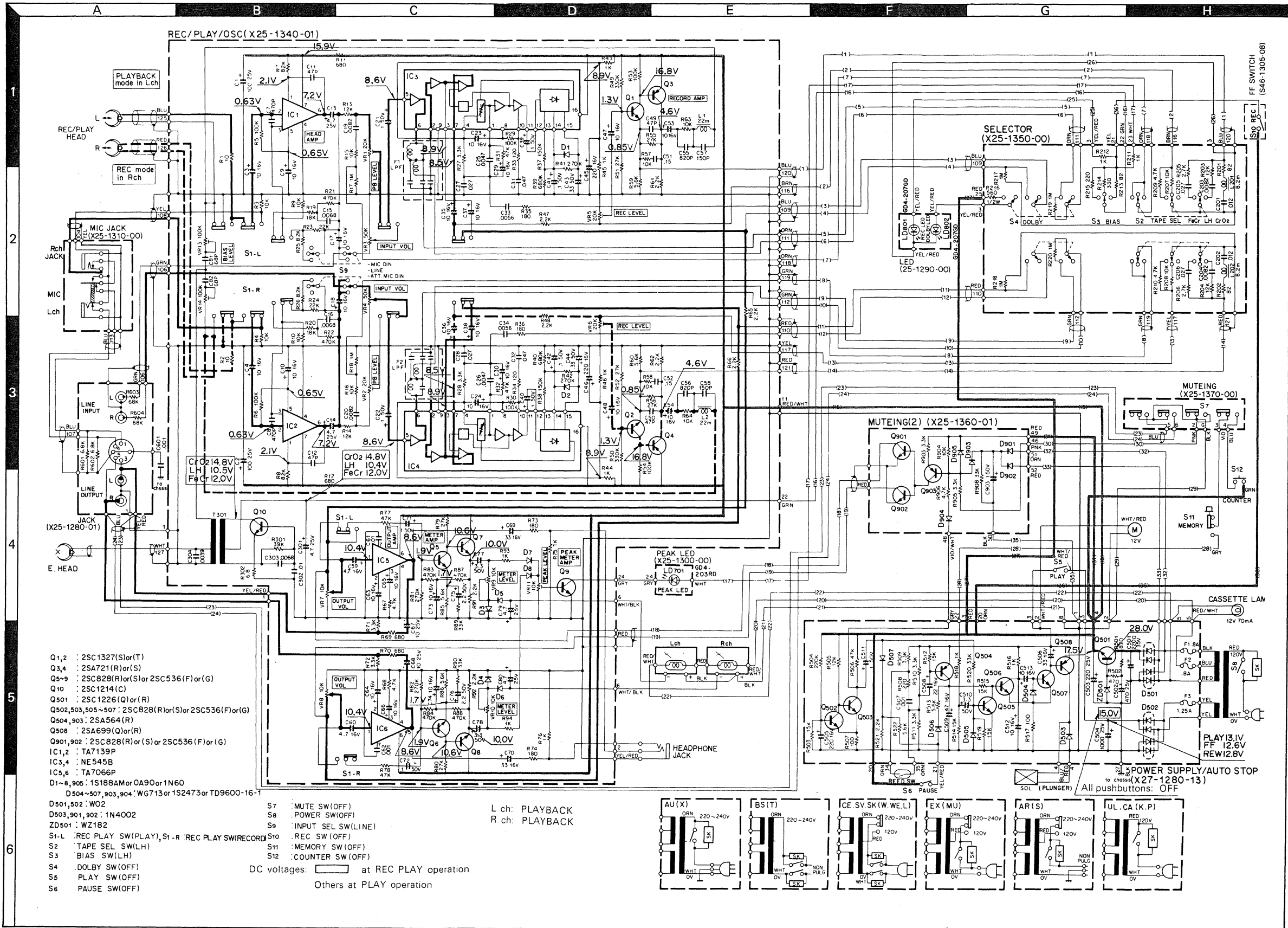

- Q1,2 : 2SC1327(S)or(T)
- Q3,4 : 2SA721(R)or(S)
- Q5-9 : 2SC828(R)or(S)or 2SC536(F)or(G)
- Q10 : 2SC1214(C)
- Q501 : 2SC1226(Q)or(R)
- Q502,503,505-507 : 2SC828(R)or(S)or 2SC536(F)or(G)
- Q504,903 : 2SA564(R)
- Q508 : 2SA699(Q)or(R)
- Q901,902 : 2SC828(R)or(S)or 2SC536(F)or(G)
- IC1,2 : TA7139P
- IC3,4 : NE545B
- IC5,6 : TA7066P
- D1-8,905 : 1S188A or OA90 or 1N60
- D504-507,903,904 : WG713 or 152473 or TD9600-16-1
- D501,502 : W02
- D503,901,902 : 1N4002
- ZD501 : WZ182
- S1-L : REC PLAY SW(PLAY), S1-R : REC PLAY SW(RECORD)
- S2 : TAPE SEL SW(LH)
- S3 : BIAS SW(LH)
- S4 : DOLBY SW(OFF)
- S5 : PLAY SW(OFF)
- S6 : PAUSE SW(OFF)
- S7 : MUTE SW(OFF)
- S8 : POWER SW(OFF)
- S9 : INPUT SEL SW(LINE)
- S10 : REC SW(OFF)
- S11 : MEMORY SW(OFF)
- S12 : COUNTER SW(OFF)

DC voltages: at REC PLAY operation
Others at PLAY operation

L ch: PLAYBACK
R ch: PLAYBACK

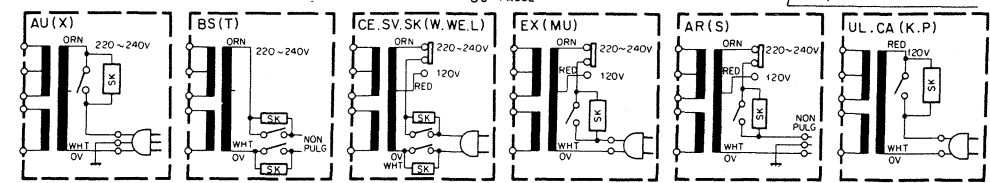

Semiconductor	Substitutions
2SA564	2SA733
2SA699	2SB595, 2SB596
2SA721	2SA640, 2SA620WB
2SC828	2SC536, 2SC945
2SC1214	-
2SC1226	2SC1013
2SC1327	2SC1000
AN360	-
NE545B	-
TA7066P	-
TAB139	-

KX-830**SPECIFICATIONS**

Type	Front Loading Stereo Cassette Deck with Dolby System
Track System	4-Track, 2-Channel Stereo/Mono Recording/Playback
Recording System	AC Bias System (Bias Frequency: 85 kHz)
Erasing System	AC System
Tape Speeds	4.76 cm/sec (1-7/8 ips)
Heads	Recording and Playback Head × 1 Erasing Head × 1
Motor	Electronically-Controlled DC Motor
Fast Winding Time	Approx. 80 seconds with C-60 tape
Frequency Response	Normal Tape: 25 Hz to 15,000 Hz (30 Hz to 13,000 Hz±3 dB) CrO ₂ Tape: 25 Hz to 17,000 Hz (30 Hz to 16,000 Hz±3 dB) Ferri-CrO ₂ Tape: 25 Hz to 17,000 Hz (30 Hz to 16,000 Hz±3 dB)
Signal to Noise Ratio:	Dolby ON (Over 5 kHz): 62 dB (Normal Tape), 64 dB (CrO ₂) Dolby OFF: 52 dB (Normal Tape), 54 dB (CrO ₂)
Harmonic Distortion	Less than 1.3% (at 1 kHz, OVU with Normal Tape)
Wow and Flutter	0.06% (WRMS)
Input Sensitivity/Impedance	Line × 2: 77.5 mV/100k ohms DIN × 1: 0.1 mV/k ohms: Europe and Scandinavia model 10.9 mV/1.5k ohms: Other Countries model Microphones × 2: 0.19 mV/10k ohms
Output Level/Load Impedance	Line × 2: 775 mV (OVU)/0.5k ohms DIN × 1: 775 mV (OVU)/0.5k ohms Headphones/1: 39 mV/8 ohms to 16 ohms
Build in Features	Dolby Noise Reduction System with Indicator Three Position Bias Selector (Normal-Chrome-Reserve) Three Position Equalization Selector (Normal-Chrome-Reserve) Input Selector Full Auto Shut-Off Mechanism in all Modes Memory Rewind LED Peak and Recording Indicator Three Digit Tape Counter Two Large Size Illuminated VU Meters Two Microphone Jacks, Headphone Jack DIN Rec/P.B. Connector
Power Requirements	AC 120V, 60 Hz: USA and Canada Model AC 220V, 50 Hz: Australia Model AC 240V, 50 Hz: U.K. Model AC 120V/220V (Switchable), 50/60 Hz: Other Countries
Power Consumption	13.0 watts
Dimensions	W: 430 mm/16-15/16" H: 167 mm/6-9/16" D: 332 mm/13-1/16"
Weight	7.5 kg, 16.5 lbs
Supplied Accessories	Stereo Connection Cord × 2 Head Cleaning Kit × 1
Reference Tape	Normal: TDK SD C-90 Chrome: TDK SA C-60 Reserve: SONY DUAD C-60

KENWOOD follows a policy of continuous advancements in development. For this reason specifications may be changed without notice.

NOTE: Dolby is trademark of Dolby Laboratories, Inc.

KENWOOD ELECTRONICS, INC.

- 1315 E.WATSON CENTER RD. CARSON, CALIFORNIA 90248 U.S.A.
- 75 SEAVIEW DRIVE SECAUCUS, NEW JERSEY 07094 U.S.A.

TRIO-KENWOOD ELECTRONICS N.V.

- LEUVENSESTEENWEG 184, B-1930 ZAVENEM, BELGIUM.

TRIO-KENWOOD ELECTRONICS GmbH.

- 6056 HEUSENSTAMM, RUDOLF-BRAAS-STR. 20, WEST GERMANY.

TRIO-KENWOOD FRANCE S.A.

- 5, BOULEVARD NEY 75018 PARIS, FRANCE.

TRIO-KENWOOD (AUSTRALIA) PTY, LTD.

- 30 WHITING ST., ARTARMON N.S.W. 2064, AUSTRALIA.

TRIO-KENWOOD CORPORATION

- 3-6-17 AOBADAI, MEGURO-KU, TOKYO, JAPAN.