

STEREO DOUBLE CASSETTE DECK CT-203/KXF-W4010/KXF-W4010E CT-2050/KXF-W6010/KXF-W6010E SERVICE MANUAL

KENWOOD

© 1998-2/B51-5413-00 (K/K) 3430

Illustration is KXF-W6010.

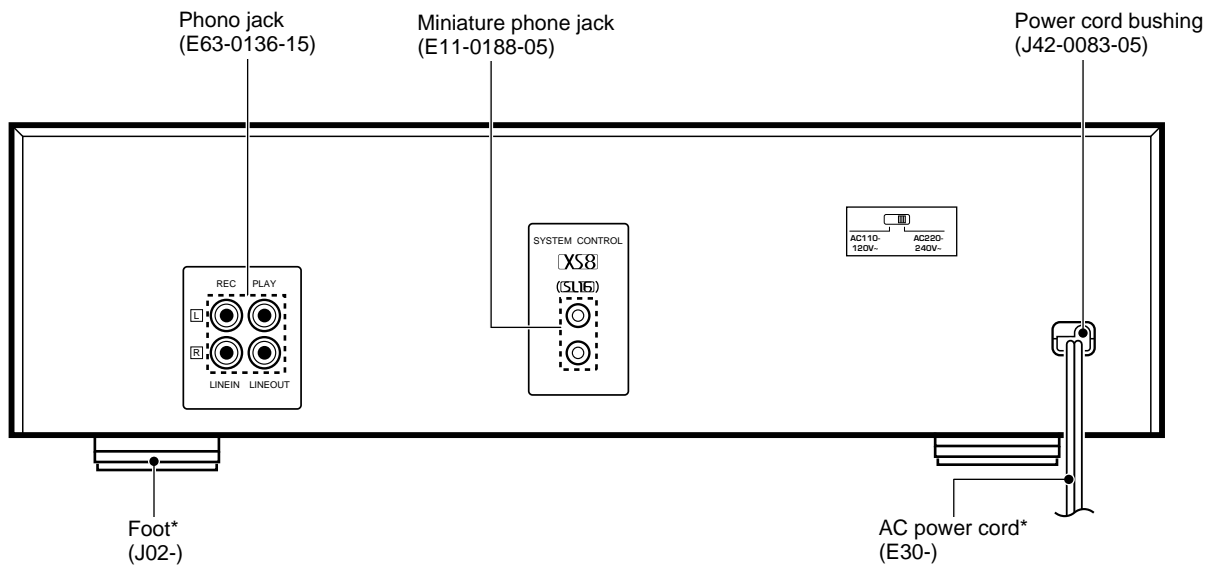
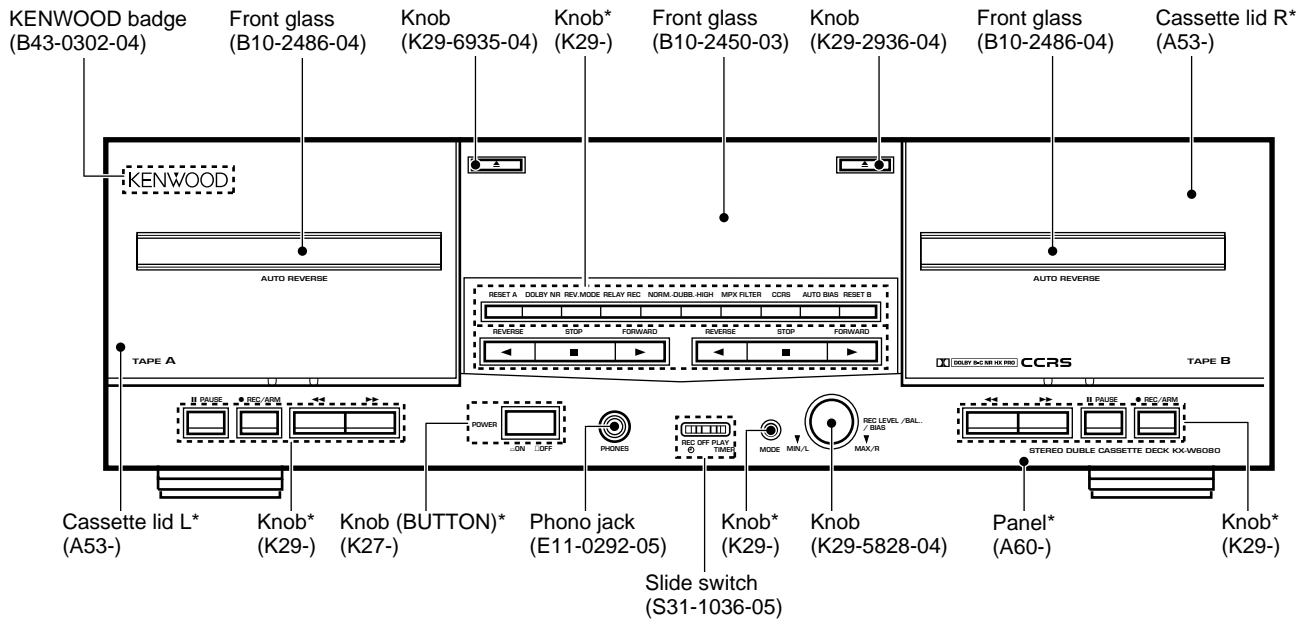

* Refer to parts list on page 18.

PRECAUTIONS FOR REPAIR

Refer to **KX-W4070/W6070** service manual(**B51-5031-00**), if you want to know more information of **CIRCUIT DESCRIPTION**.

CT-203/2050/KXF-W4010/W6010

CONTENTS / ACCESSORIES / CAUTIONS

Contents

CONTENTS / ACCESSORIES / CAUTIONS.....	2	SCHEMATIC DIAGRAM	9
CONTROLS	3	EXPLODED VIEW	16
ADJUSTMENT	5	PARTS LIST.....	18
PC BOARD	7	SPECIFICATIONS	23

Accessories

Audio cord2
(E30-0505-05)

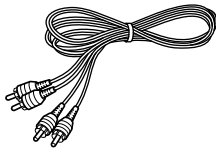

System control cord1
(E30-2816-05)

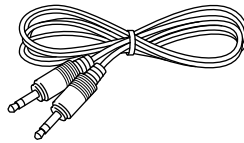

Except for U.S.A., Mexico, Canada,
U.K., Europe and Australia

AC plug adaptor.....1
(E03-0115-05)

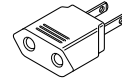

Note : CT-203 and CT-2050 is for USA and Canada market.

Operation to reset

The microcomputer may fail into malfunction (impossibility to operate, erroneous display, etc.) When the power cord is unplugged while this unit is ON or due to an external factor. In this case, execute the following method to reset the microcomputer and return it to normal condition.

Turn the power switch on and off again while pressing the stop (■)key on desk B.

- Please note that resetting microcomputer clears contents stored in and returns it to the condition when it left the factory.

Cautions

Beware of condensation

When water vapor comes into contact with the surface of cold material, water drops are produced. If condensation occurs, correct operation may not be possible, or the unit may not function correctly. This is not a malfunction, however, and the unit should be dried. (To do this, turn the POWER switch ON and leave the unit for several hours.)

Be especially careful in the following conditions:

- When the unit is brought from a cold place to a warm place, and there is a large temperature difference.
- When a heater starts operating.
- When the unit is brought from an air-conditioned place to a place of high temperature with high humidity.
- When there is a large difference between the internal temperature of the unit and the ambient temperature, or in conditions where condensation occurs easily.

CONTROLS

This illustration shows the KXF-W6010 model.

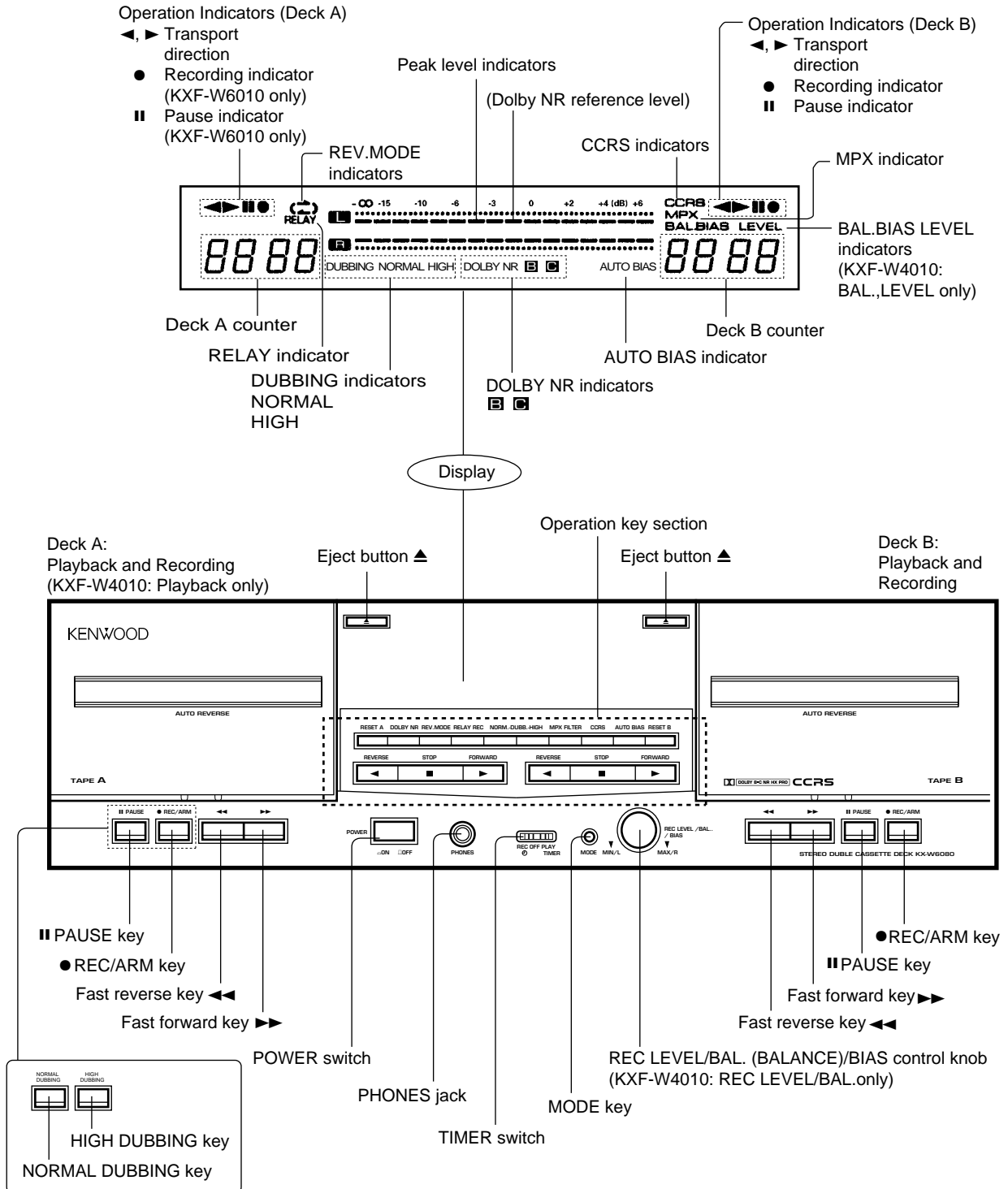

CONTROLS

■ Operation key section (KXF-W6010)

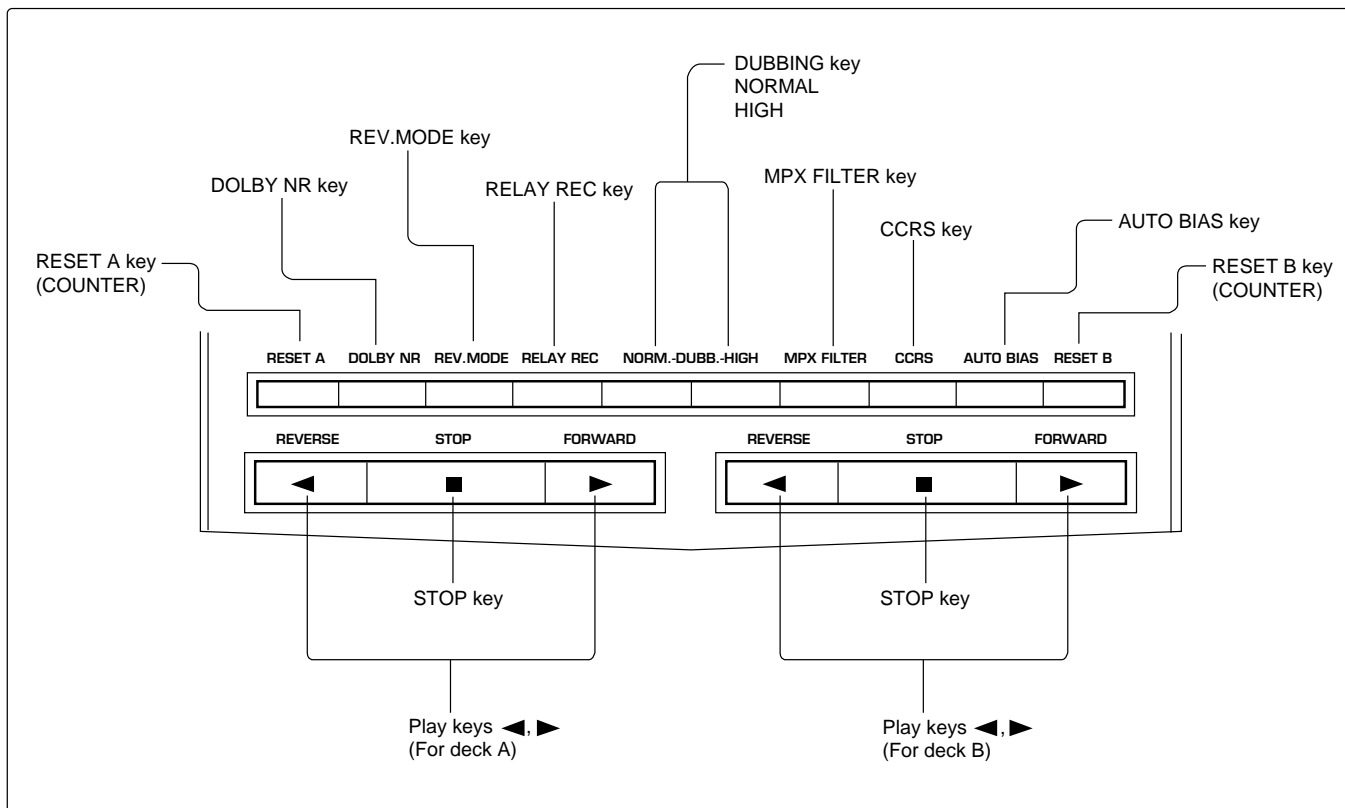

■ Operation key section (KXF-W4010)

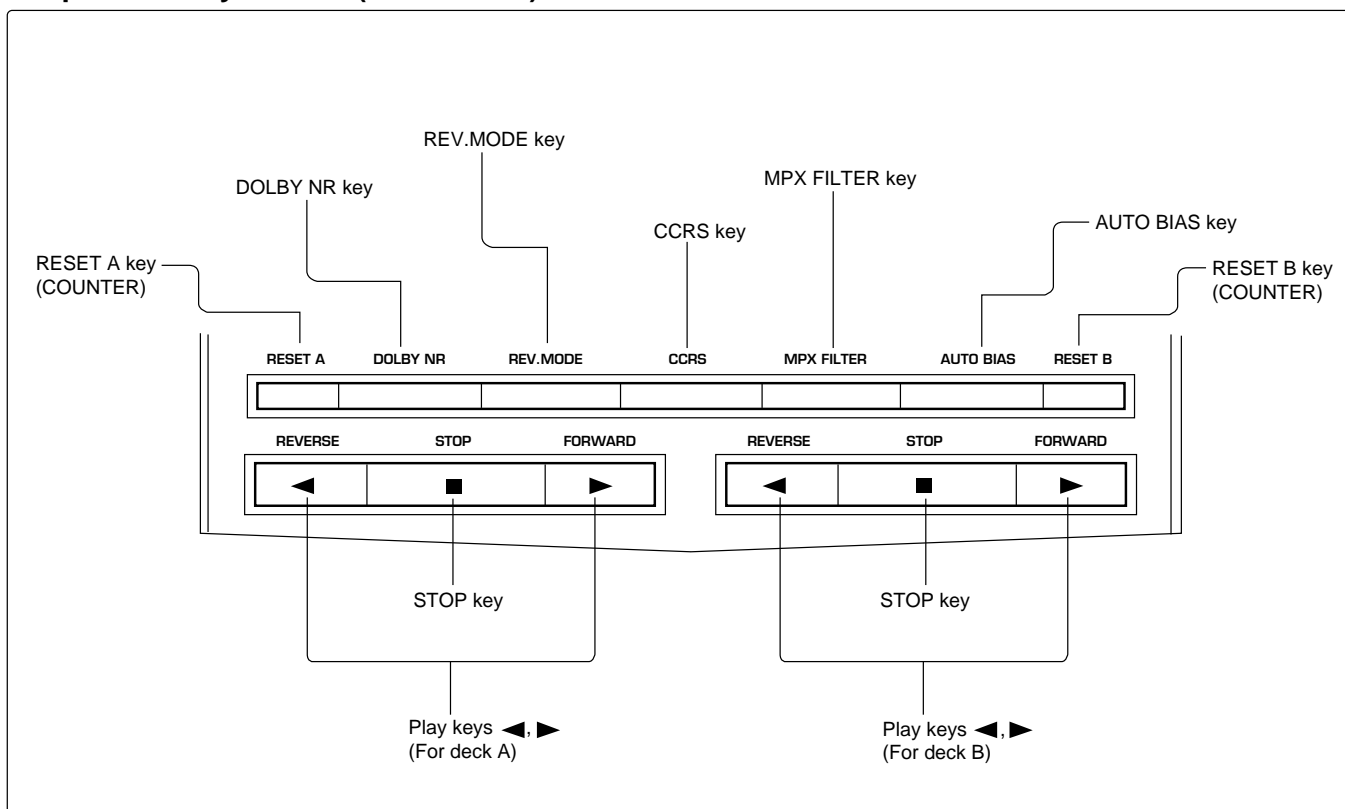

ADJUSTMENT

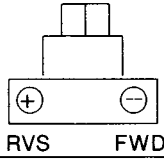
No.	ITEM	INPUT SETTING	OUTPUT SETTING	DECK SETTING	ALIGNMENT POINTS	ALIGN FOR	FIG.
Unless otherwise specified, set the respective switches as follows : TAPE : NORMAL, DOLBY : OFF 0dBs = 0.775V							
I. Cassette mechanism section(Adjustment of the REC/PLAY HEAD)							
(1)	DEMAGNETIZATION and CLEANING	—	—	POWER OFF Demagnetization Cleaning PLAY	REC/PLAY head Erase head Capstan Pinch roller	Demagnetize the REC/PLAY head with a head eraser. Clean the REC/PLAY head erase head, capstan and pinch roller using a cotton swab slightly damped with alcohol.	
(2)	AZIMUTH of the REC/PLAY HEAD	SCC-1727 TCC-153 MTT-114 10kHz, -10dB	—	PLAY	 RVS FWD	Adjust the output to maximum and adjust the azimuth adjustment screw for the Lissajous waveform pattern of the oscilloscope to become close to a 45° straight line.	(a)
II. PC BOARD adjustment Note : Carry out the high-speed adjustment in the first place.							
[1]	TAPE SPEED (HI SPEED)	SCC-1727 TCC-110 MTT-111 3kHz	—	*TEST MODE	VR1 (A) VR2 (B)	Adjust the tape speed so that 6kHz is obtained at the center of the tape.	
[2]	TAPE SPEED (NORMAL)				VR3 (A) VR4 (B)	Adjust the tape speed so that 3kHz is obtained at the center of the tape.	

*Short circuit TP5, TP6 by diode (TP5 \leftarrow TP6) and turn the POWER ON. FF key : High-speed, PLAY key : Normal-speed.

System connections

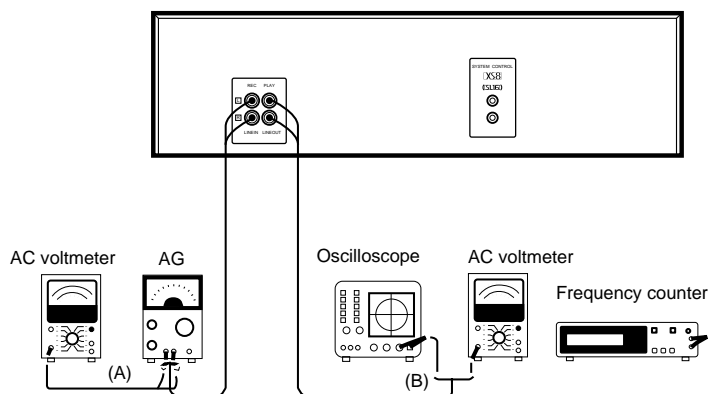

(a) Azimuth adjustment screw

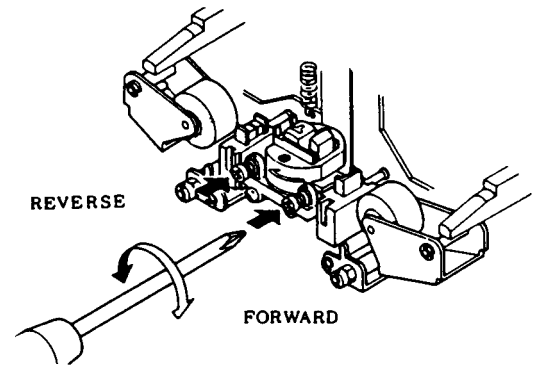

* Please refer to Automatic Adjustment for Playing, Recording, BIAS level adjustment.

ADJUSTMENT

Playback Level & REC Level Adjustment

1. Automatic adjustment

• Playback level adjustment

1. Turn the POWER OFF (AC OFF).
2. Insert the TCC-130 into respective deck A or B.
3. Short TP4-TP6 and turn the AC plug receptacle ON.
4. When "END P" is displayed in FL, adjustment is complete.

If an error occurs, it will display the location causing the "CAL E", "PL E", etc.

Turn the POWER OFF (AC OFF) or the REC PAUSE key twice (one press is for the test mode) to return to normal operation.

• Recording level and bias adjustment

1. Turn the POWER OFF (AC OFF).
2. Insert the TCC-106A into deck B.
3. Short TP4-TP6 and turn the AC plug receptacle ON.
4. When "END" is displayed in FL, adjustment is complete.

If an error occurs, it will display the location causing the "RL E", "BL E", etc.

Turn the POWER OFF (AC OFF) or the PAUSE key twice (one press is for the test mode) to return to normal operation.

• Indication items of FL tube

END P..... Normal completion state of playback level adjustment mode.

END..... Normal completion state of all (playback/REC level) adjustment mode.

CAL E..... Lch ERR state of sensitivity correction.

CAR E..... Rch ERR state of sensitivity correction.

Counter A

PL E..... Lch ERR state of A PB adjustment.

PR E..... Rch ERR state of A PB adjustment.

Counter B

PL E..... Lch ERR state of B PB adjustment.

PR E..... Rch ERR state of B PB adjustment.

Counter B

RL E..... Lch ERR state of B REC EQ adjustment.

RR E..... Rch ERR state of B REC EQ adjustment.

Counter B

BL E..... Lch ERR state of B BIAS adjustment.

BR E..... Rch ERR state of B BIAS adjustment.

NOTE :

- The playback level can be adjusted independently for A or B. The procedure in this case as well is as in the above procedure.
- Turn off the display to suppress power fluctuations and other such problems during automatic adjustment.
- The playback level adjustment is done with the DOLBY level as the standard value, so be sure to use a 200nWb/m (315Hz or 400Hz) tape.

2. Manual adjustment

• Playback level adjustment

1. Turn the POWER OFF (AC OFF).
2. Turn the AC plug receptacle ON while shorting the TP7-TP6. Then open TP7-TP6.
3. Insert the TCC-130 into deck A and play.

4. Deck A Lch level adjustment

The initial FL display is "PL 00". The "00" displays the step number. Since the initial value is set at 30, adjust it at this setting by turning the REC LEVEL ($\sqrt{\Delta}$) key.

Adjustment level : TCC-130 (200nWb/m) → -1dBs (690mV). When using 160nWb/m or 250nWb/m tapes set to 4dBs and 0dBs respectively.

5. Press the DUBB NOR key.
6. When the DISPLAY key is pressed, the display switches to the "PR 00".
7. Deck A Rch level adjustment : Same as Lch
8. Press the DUBB NOR key.
9. Press the DISPLAY key.
10. Insert the TCC-130 into deck B and play.
11. Deck B Lch level adjustment
12. Press the DUBB NOR key.
13. Press the DISPLAY key.
14. Deck B Rch level adjustment
15. Press the DUBB NOR key.
16. Press the DISPLAY key.

• Recording level and bias adjustment

1. Insert the recording tape into deck B (A BEX TCC-108A or TDK AC-225) and set the AG to 400Hz.
2. Press the REC key to start recording and adjust the AG so that the output becomes -20dBs. (If you press the PAUSE key at this time, manual adjustment will be cancelled, so be careful.) Playback the recorded tape and turn the level volume so that the output becomes -20dBs. (It changes about 0.2dB with each step.) Lch REC level adjustment.
3. Press the DUBB NOR key.
4. Press the DISPLAY key.
5. Rch REC level adjustment : Same as Lch
6. Press the DUBB NOR key.
7. Press the DISPLAY key.
8. Set the AG to 125kHz, then press the REC key to begin recording. Adjust the AG so that the output becomes -20dBs. Playback the recorded tape and adjust the level volume so that the output becomes -20dBs. (It changes about 0.4dB-0.5dB with each step.) Lch REC bias adjustment.
9. Press the DUBB NOR key.
10. Press the DISPLAY key.
11. Deck B Rch bias adjustment
12. Press the DUBB NOR key.

NOTE :

- The PAUSE key cancels the Adjustment mode, so do press it during adjustment.
- When adjusting manually, the DUBB NOR key and DUBB HIGH key respectively become the MODE WRITE and ALL WRITE keys, so you need not press the DUBB NOR key for each adjustment mode and can just press the DUBB HIGH key when all the adjustments have been completed.
- When manual adjustment is turned on, all the adjustment data is initialized, so whether or not you make an adjustment, at the end, after writing data, you should cancel using the DUBB HIGH key or another key.

PC BOARD(Component side view)

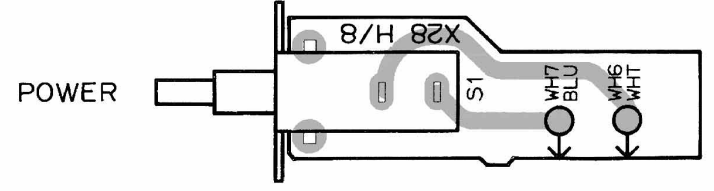
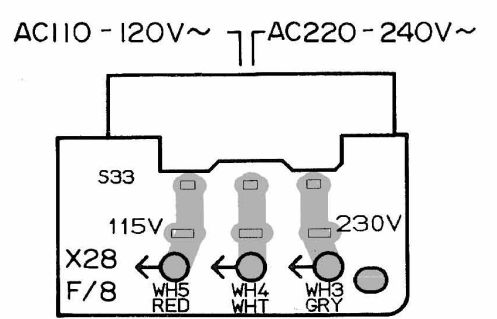
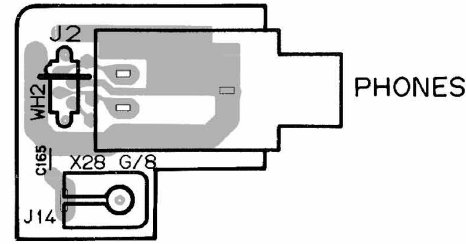
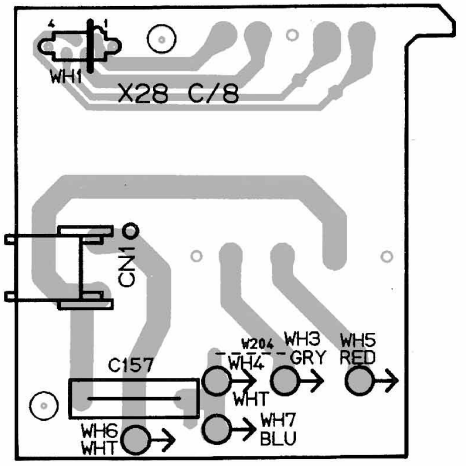
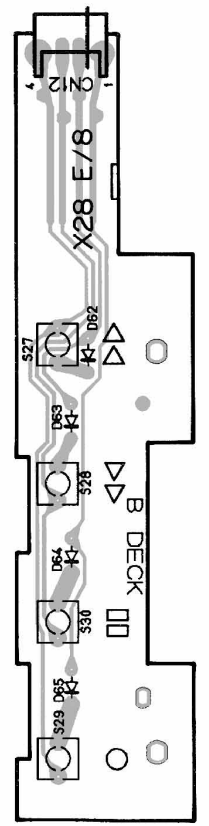
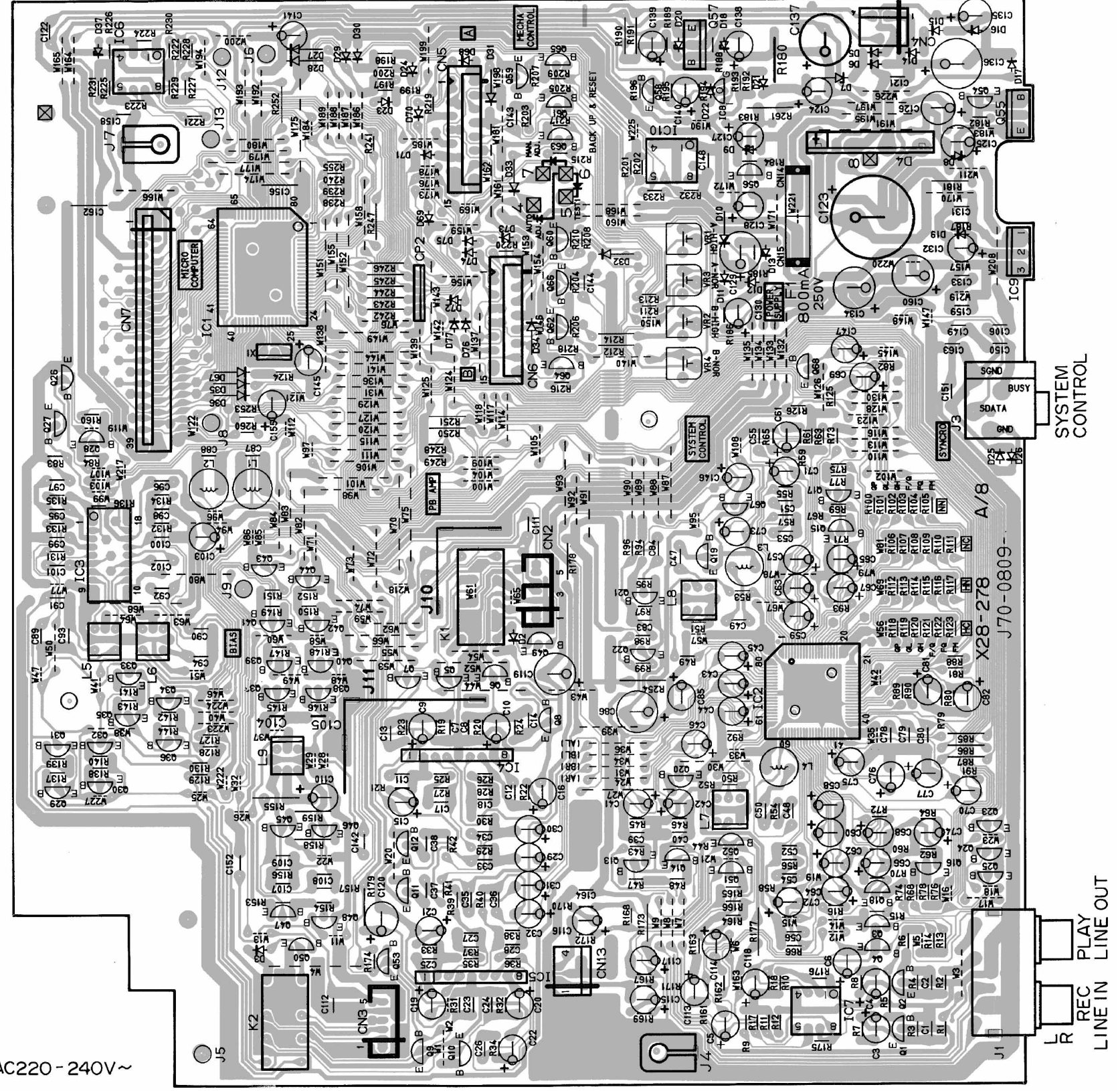
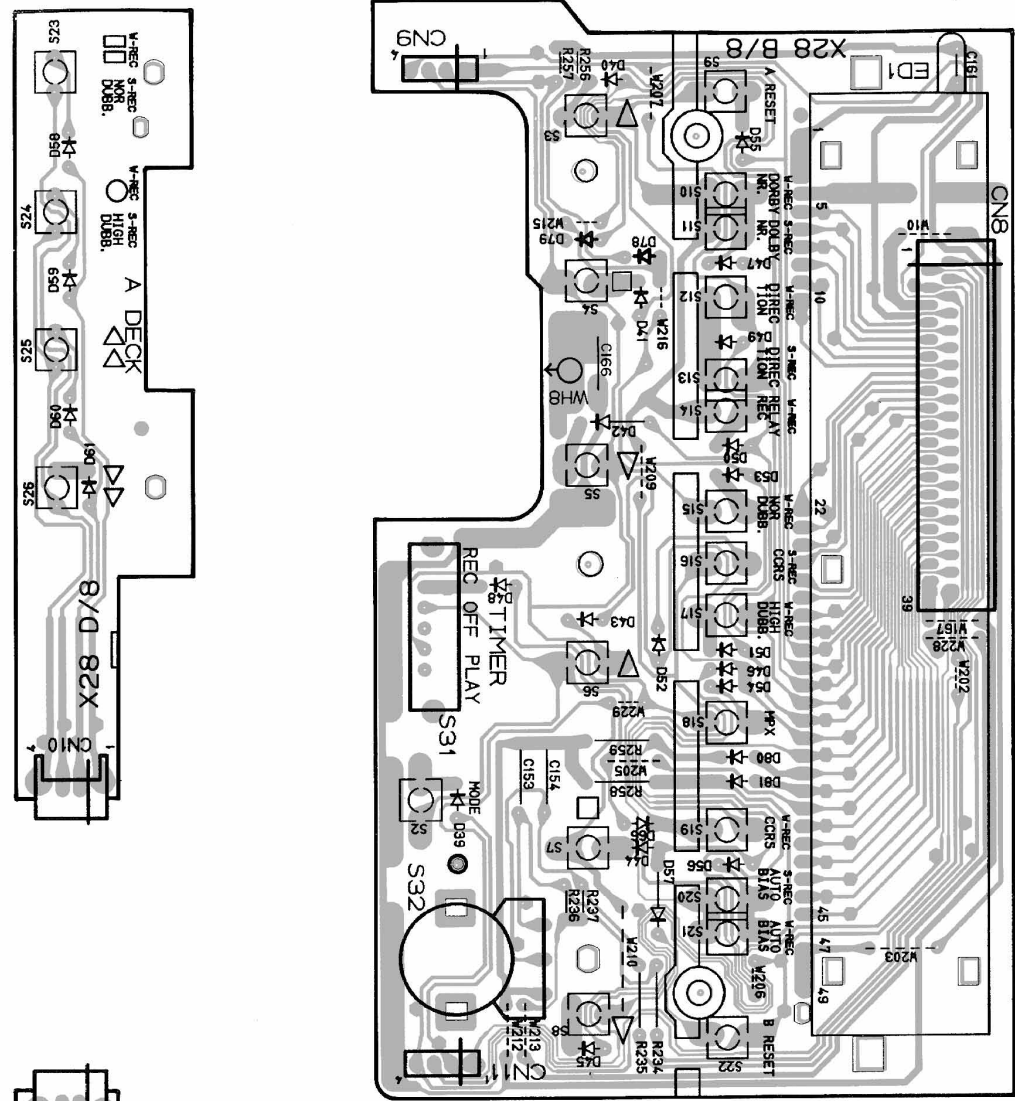

Refer to the schematic diagram for the value of resistors and capacitors.

IC1 : CXP82540-136Q	Q1-4, 15, 16 : 2SD1450(S, T)	D2, 3, 5, 6, 10-12 : 1SS133 or HSS104
IC2 : HA12167FB	Q5-12, 19, 20, 22 : DTC124ES or UN4212	
IC3 : UPC1297CA	Q26-28, 43, 44 : 2SC3311A(Q, R) or 2SC2458(Y, GR) or DTA124ES or UN4112	D4 : D3SBA20F03 or RBV-402LFA
IC4, 5 : TA8125S	Q13, 14, 17, 18 : 2SC2003(L, K) or 2SA992(F, E) or 2SA1534A(R, S) or 2SD2374	D7 : HZS6. 8N(B2) or RD6. 8ES(B2)
IC6 : BA10393	Q23-25 : 2SC1845(F, E) or 2SC2003(L, K) or 2SA992(F, E) or 2SA1534A(R, S) or 2SD2374	D8 : HZS13N(B2) or RD13ES(B2)
IC7 : NJM4558D	Q37-40 : 2SC3246 or 2SA1535A	D13 : HZS3. 9N(B2) or RD3. 9ES(B2)
IC8 : S-806D-Z	Q56, 59, 60, 63, 64 : 2SC3246 or 2SA1535A	D18 : HZS20N(B) or RD20ES(B)
IC9 : BA17812T or UPC7812AHF	Q57 : 2SA1309A(Q, R) or 2SA1048(Y, GR)	D37 : HZS2. 7N(B2) or RD2. 7ES(B2)
IC10 : XL24C01AP	Q61, 62 : 2SA1048(Y, GR)	

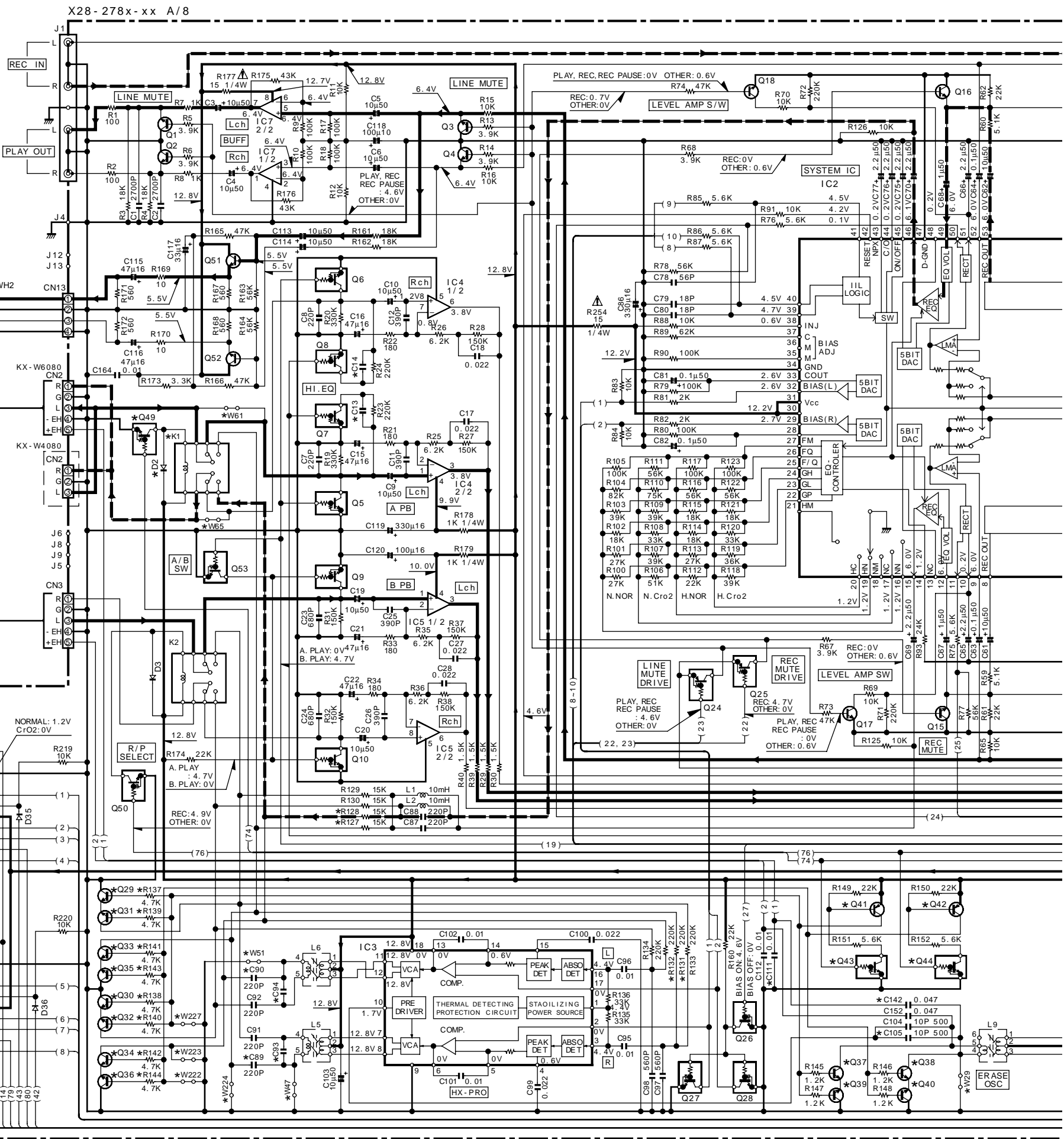
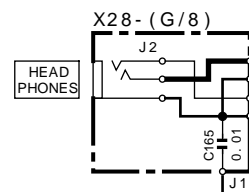
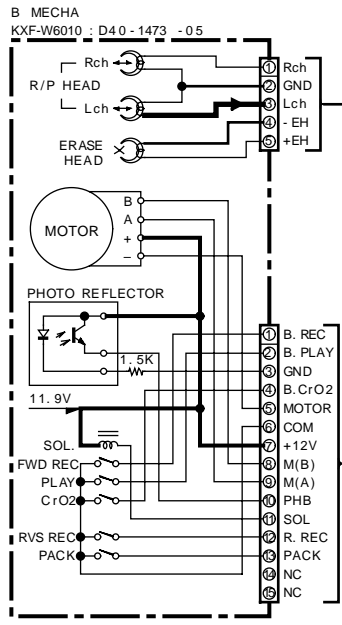
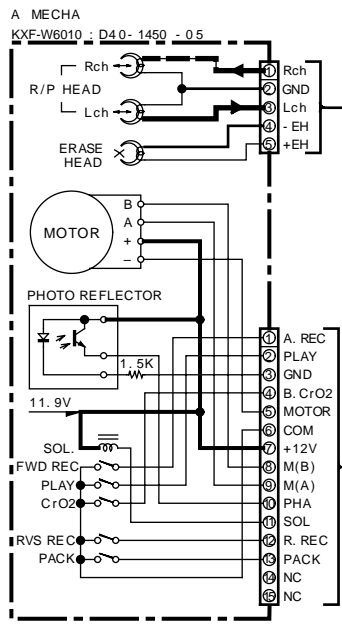
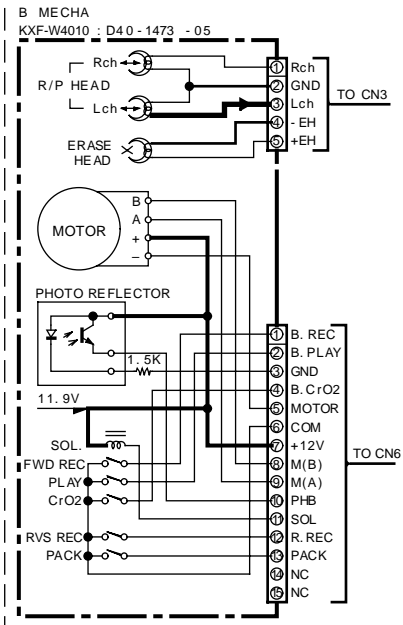
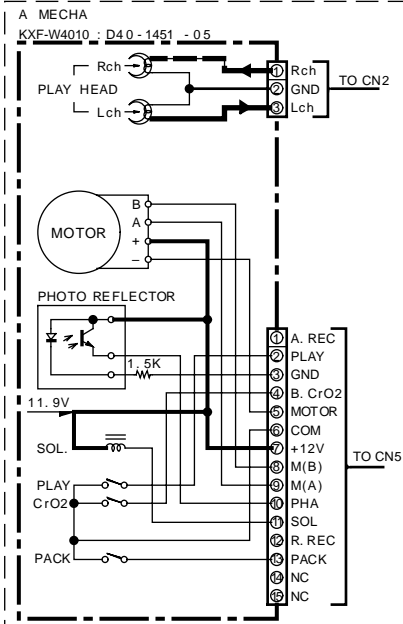

CAUTION: For continued safety, replace safety critical components only with manufacturer's recommended parts (refer to parts list). * indicates safety critical components. For continued protection against risk of fire, replace only with same type and rating fuse(s). To reduce the risk of electric shock, leakage-current or resistance measurements shall be carried out (exposed parts are acceptably insulated from the supply circuit) before the appliance is returned to the customer.

DOLBY and the double-D symbol are trademarks of Dolby Laboratories Licensing Corporation. Noise reduction circuit made under license from Dolby Laboratories Licensing Corporation.

The DC voltage is an actual reading measured with a high impedance type voltmeter with a cassette loaded at playback mode. The measurement value may vary depending on the measuring instruments used or on the product. Bias circuit DC voltage is measured while in the record mode.

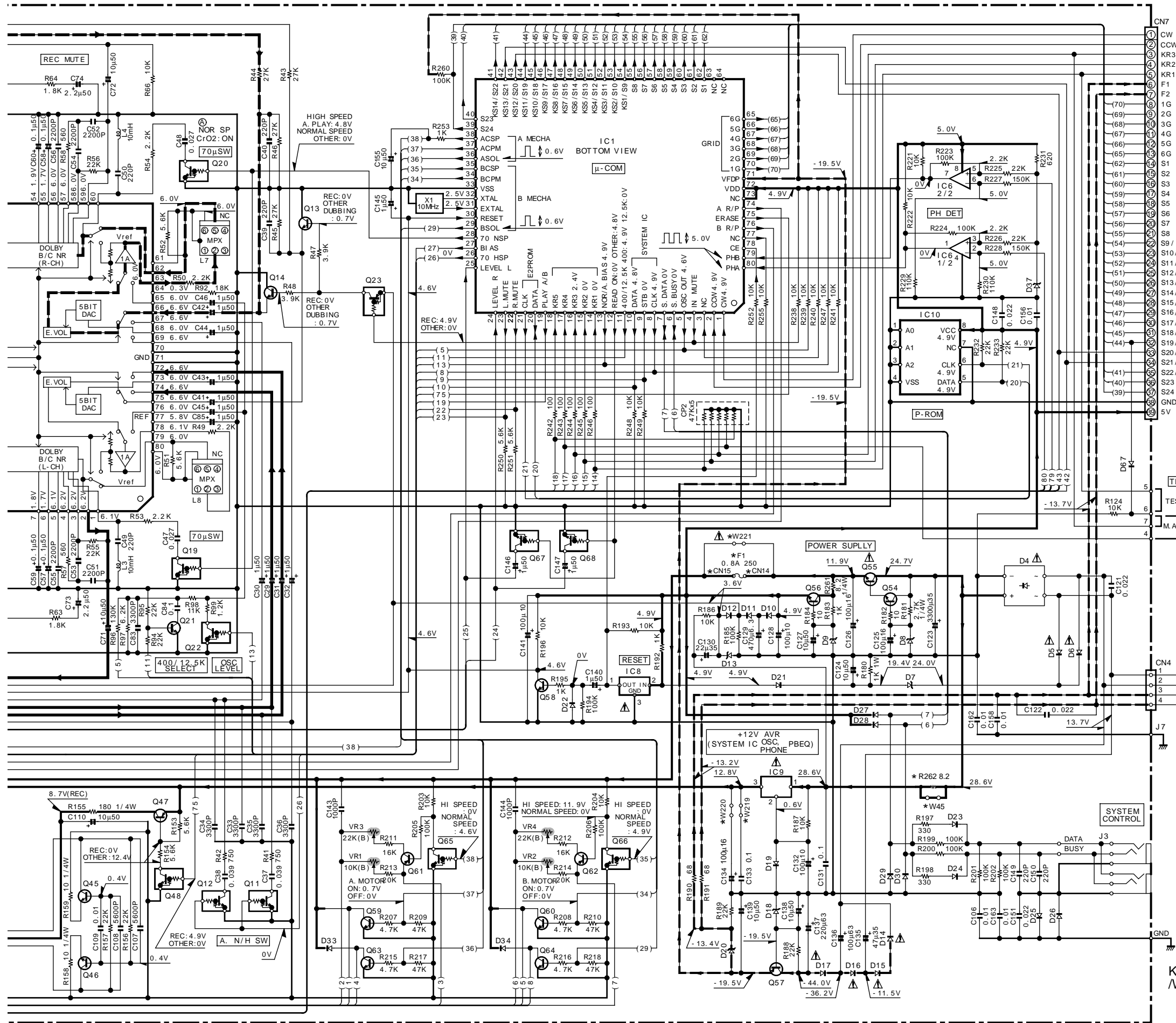

TO X28 CN8 (A) 2/2

MODEL NAME	DESTINATION		UNIT NO.	F1 CN14, 15 R262	W45 W221
	COUNTRY	ABB.			
CT-2050	USA	K, P	0-10	YES	NO
KXF-W6010(E)	EUROPE	T, E, E1	2-71	NO	YES
CT-203	USA	K, P	0-11	YES	NO
KXF-W4010(E)	EUROPE	X, T, E, E1	2-72	NO	YES
	GENERAL MARKET	Y, M	0-22		

MODEL NAME	ABB.	UNIT NO.	C13, 14	C93, 94	W29, 47, 51 61, 65 222-224 227	K1 C89, 90, 105 111, 142, Q29-44, 49 R127, 128, 131 132, 137-144	D2
CT-2050	K, P	0-10					
KXF-W6010(E)	X, T, E	2-71	470P	220P	NO	YES	
CT-203	K, P	0-11					
KXF-W4010(E)	X, T, E	2-72	680P	150P	YES	NO	
	Y, M, E1	0-22					

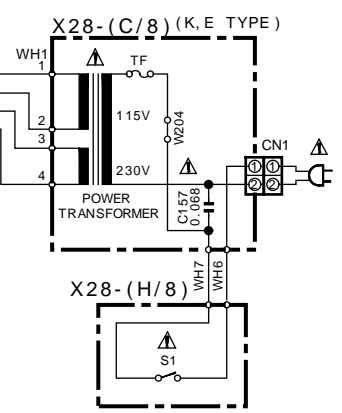
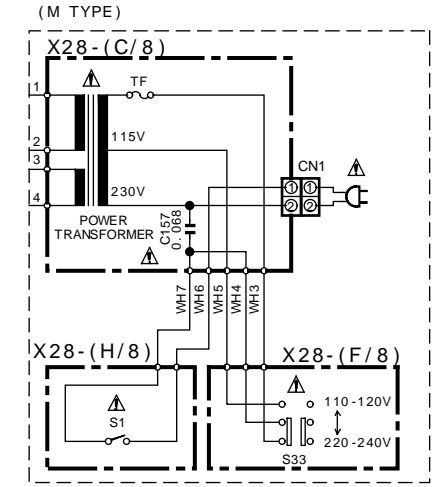

——— SIGNAL LINE
 - - - - RECORDING LINE
 GND LINE
 + B LINE
 - B LINE

KXF-W4010(CT-203)
/W6010(CT-2050)(K) (1/2)

X28-278x-xx (B/8)

ED1

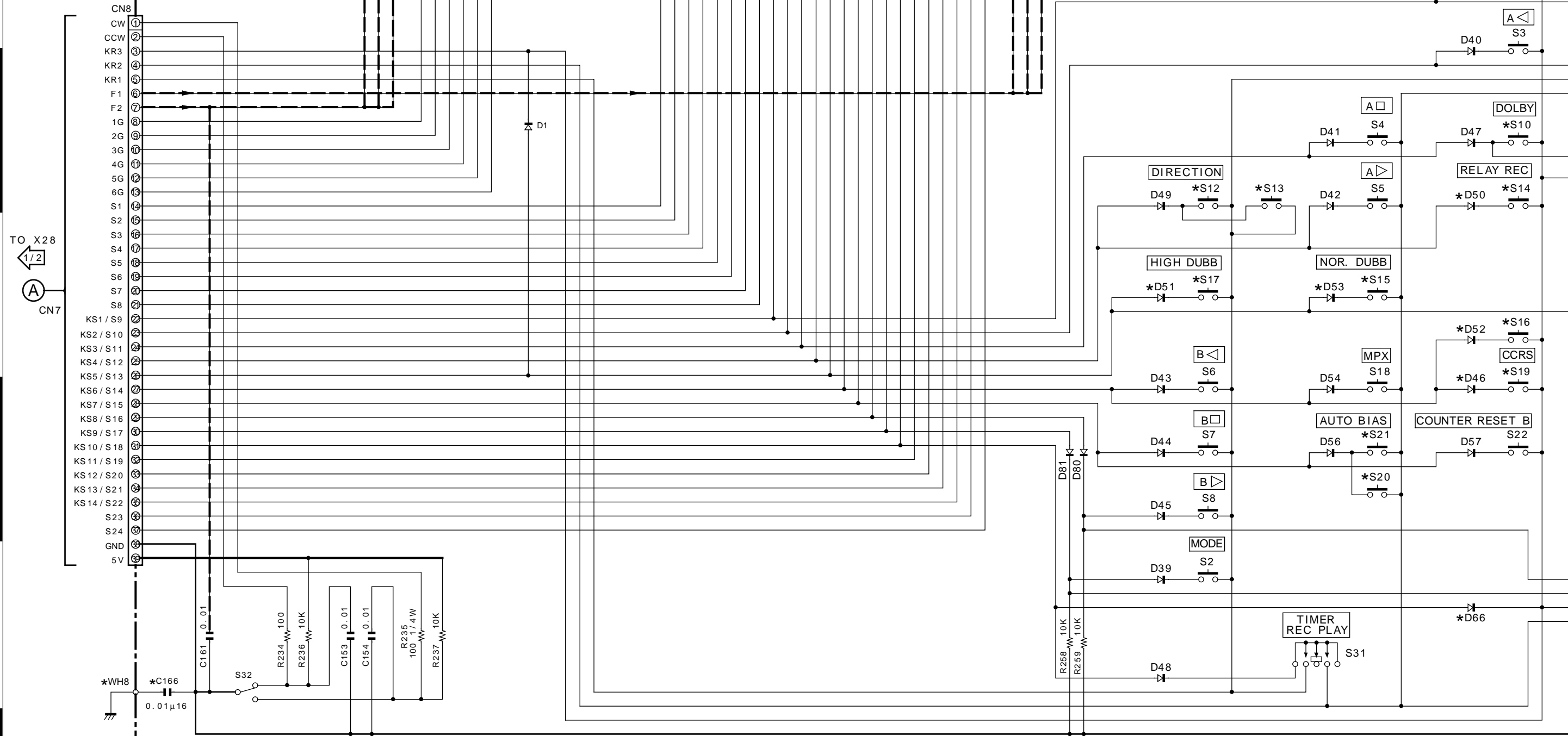
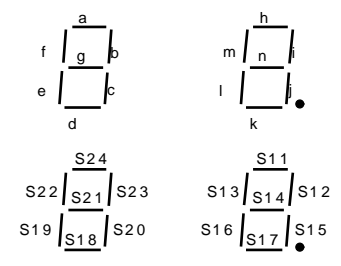
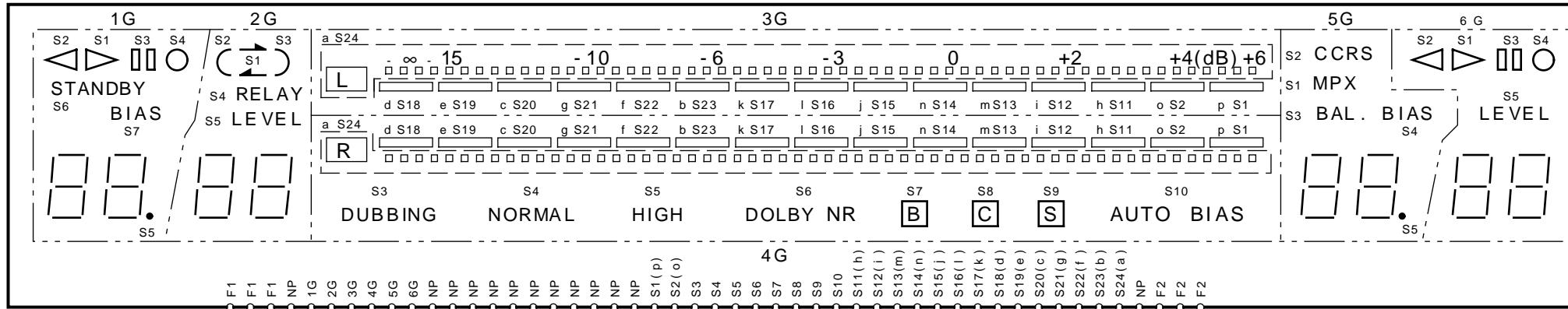

COUNTER RESET A

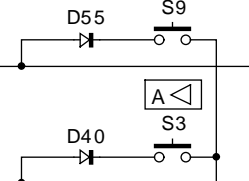

DIRECTION

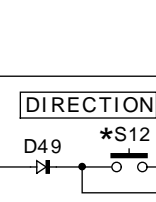

HIGH DUBB

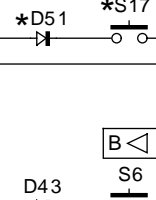

B <

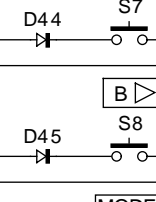

B >

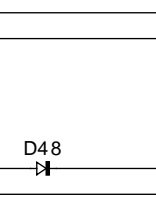

MODE



A <

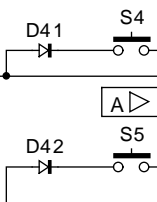

NOR. DUBB

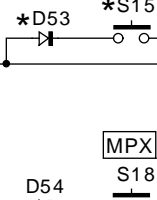

MPX

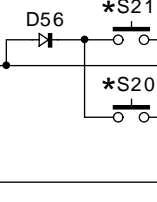

AUTO BIAS

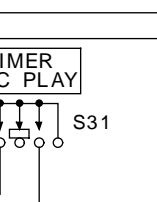

COUNTER RESET B



TIMER REC PLAY

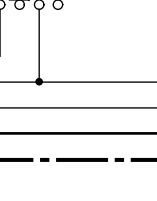

TO X28
1/2
A
CN7

6

7

X28 - 278 x - x x

MODEL NAME	DESTINATION		UNIT NO.	S 10, 12, 14, 15 17, 19, 21 D46, 50, 51 53, 66 W215	S 11, 13 16, 20 D52 W216	D78	C166 WH8
	COUNTRY	ABB.					
CT-2050	USA	K, P	0 - 10	YES	NO	1SS199	YES
KXF-W6010(E)	EUROPE	T, E, E1	2 - 71				
	GENERAL MARKET		M	0 - 21			
CT-203	USA	K, P	0 - 11	NO	YES	1SS133 or HSS104	NO YES
KXF-W4010(E)	EUROPE	X, T, E, E1	2 - 72				
	GENERAL MARKET		Y, M	0 - 22			

HA12167FB

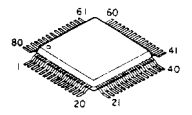

TA8125S

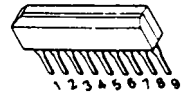

ED1 : FIP6AMW6
 D1, D39-66, 80, 81 : 1SS133 or HSS104
 *D78
 D79 : 1SS199

CAUTION: For continued safety, replace safety critical components only with manufacturer's recommended parts (refer to parts list). Δ indicates safety critical components. For continued protection against risk of fire, replace only with same type and rating fuse(s). To reduce the risk of electric shock, leakage-current or resistance measurements shall be carried out (exposed parts are acceptably insulated from the supply circuit) before the appliance is returned to the customer.

The DC voltage is an actual reading measured with a high impedance type voltmeter with a cassette loaded at playback mode. The measurement value may vary depending on the measuring instruments used or on the product. Bias circuit DC voltage is measured while in the record mode.

DOLBY and the double-D symbol are trademarks of Dolby Laboratories Licensing Corporation. Noise reduction circuit made under license from Dolby Laboratories Licensing Corporation.

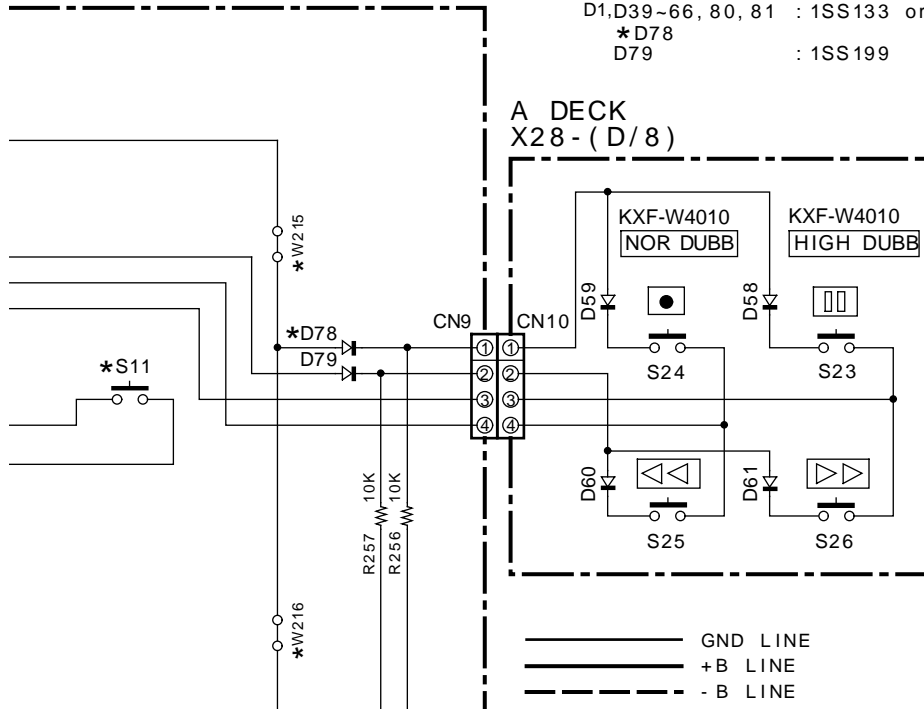

— GND LINE
 = +B LINE
 - - - - B LINE

2SA1534A
 2SA992
 2SC1845
 2SC2003
 2SC3246

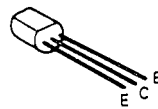

DTA124ES
 DTC124ES
 UN4112
 2SA1048
 2SC2458

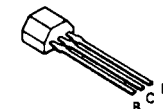

2SA1535A



UN4212
 2SA1309A
 2SC3311A

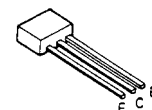

NJM4558D

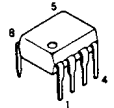

B DECK
 X28 - (E/8)

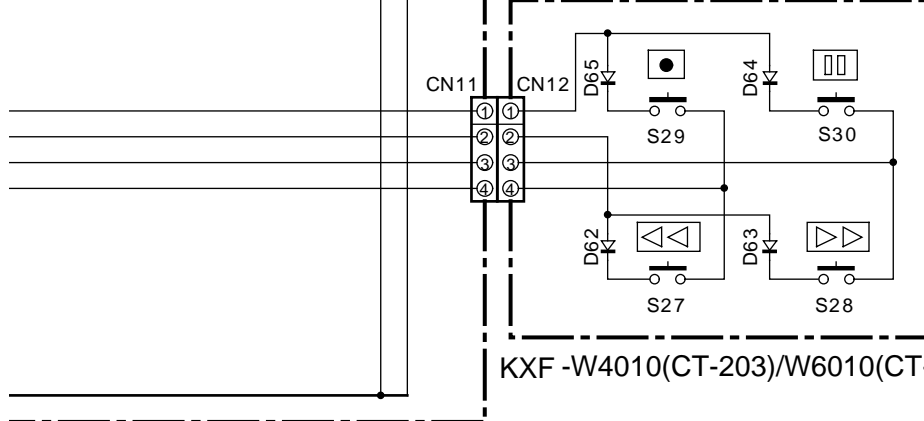

2SD2374



BA17812T
 UPC7812AHF

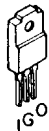

BA10393
 XL24C01AP

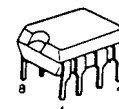

UPC1297CA

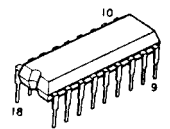

KXF -W4010(CT-203)/W6010(CT-2050)(K) (2 / 2)

CT-203/2050/KXF-W4010/W6010

EXPLODED VIEW (MECHANISM)

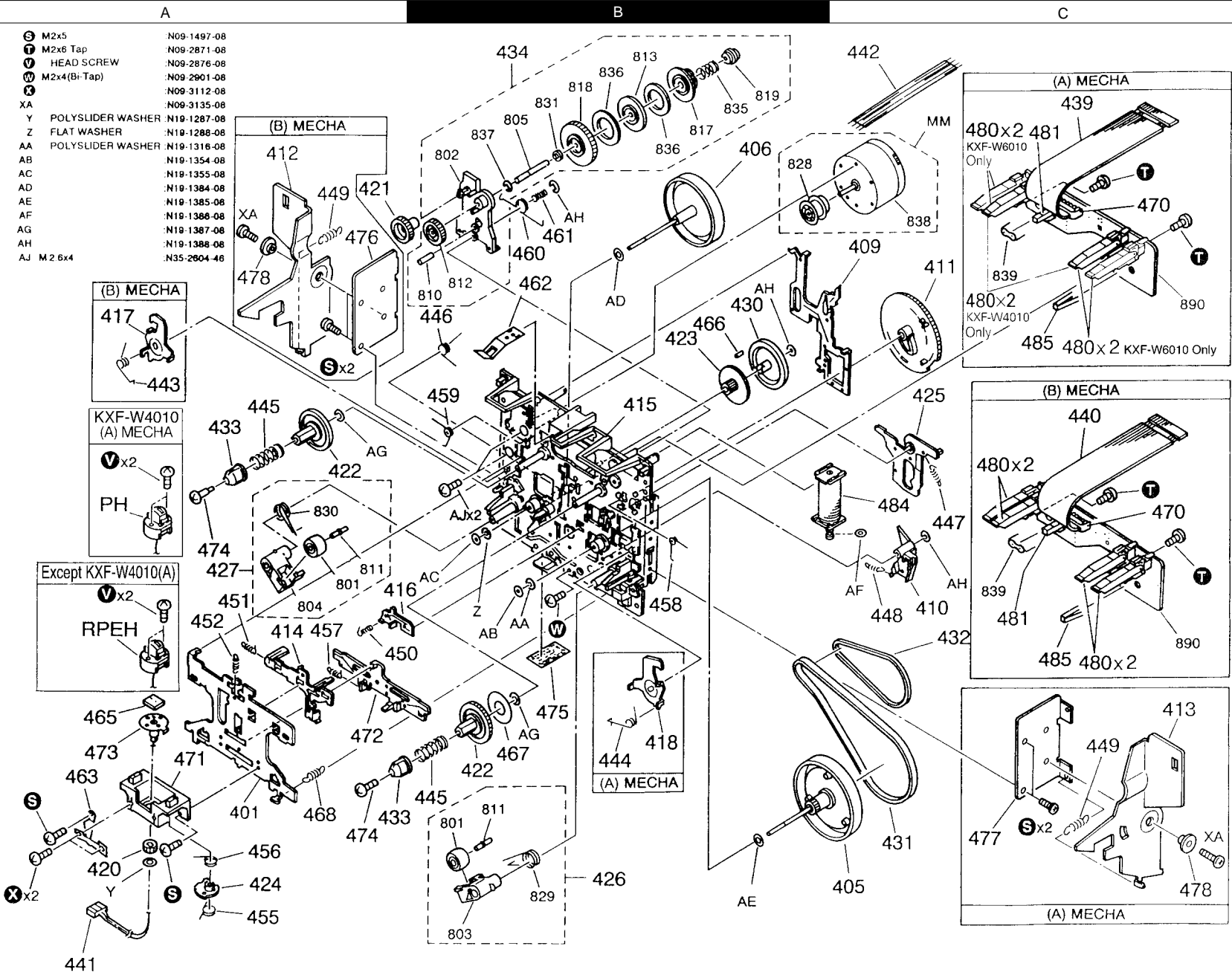

Parts with the exploded numbers larger than 700 are not supplied.

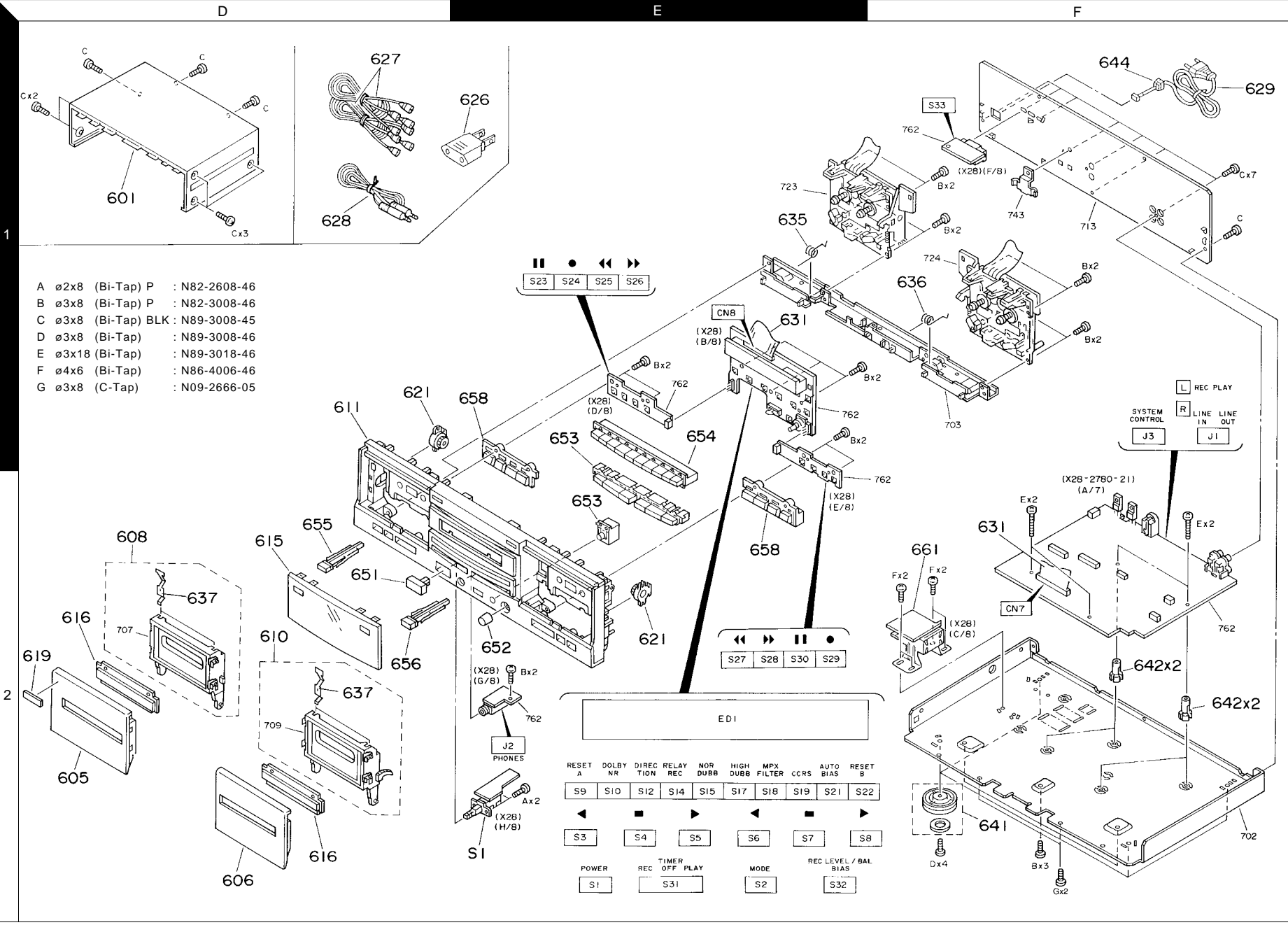

- A \varnothing 2x8 (Bi-Tap) P : N82-2608-46
- B \varnothing 3x8 (Bi-Tap) P : N82-3008-46
- C \varnothing 3x8 (Bi-Tap) BLK : N89-3008-45
- D \varnothing 3x8 (Bi-Tap) : N89-3008-46
- E \varnothing 3x18 (Bi-Tap) : N89-3018-46
- F \varnothing 4x6 (Bi-Tap) : N86-4006-46
- G \varnothing 3x8 (C-Tap) : N09-2666-05

EXPLODED VIEW (UNIT)

CT-203/2050/KXF-W4010/M6010

* New Parts
Parts without **Parts No.** are not supplied.
Les articles non mentionnés dans le **Parts No.** ne sont pas fournis.
Teile ohne **Parts No.** werden nicht geliefert.



Ref. No	Add-ress	New Parts	Parts No.	Description	Desti-nation	Re-marks
CT-203(KXF-W4010)/CT-2050(KXF-W6010)						
601	1D	*	A01-3555-01	METALLIC CABINET		
605	2D	*	A53-2038-12	CASSETTE LID L	KP	4
605	2D	*	A53-2040-12	CASSETTE LID L	Y	4
605	2D	*	A53-2041-12	CASSETTE LID L	KP	6
605	2D	*	A53-2063-02	CASSETTE LID L	MXTEE1	4
605	2D	*	A53-2065-02	CASSETTE LID L	MTEE1	6
606	2D	*	A53-2039-12	CASSETTE LID R	KPY	
606	2D	*	A53-2064-02	CASSETTE LID R	MXTEE1	
608	2D	*	A53-2061-03	CASSETTE HOLDER ASSY,L		
610	2D	*	A53-2062-03	CASSETTE HOLDER ASSY,R		
611	1D	*	A60-1360-11	PANEL	KPY	4
611	1D	*	A60-1361-11	PANEL	KP	6
611	1D	*	A60-1458-01	PANEL	MXTEE1	4
611	1D	*	A60-1459-01	PANEL	MTEE1	6
615	2D	*	B10-2450-03	FRONT GLASS		
616	2D	*	B10-2486-04	FRONT GLASS		
619	2D		B43-0302-04	KENWOOD BADGE		
			B46-0096-53	WARRANTY CARD	X	4
			B46-0197-00	QUESTIONNAIRE CARD	K	
			B46-0310-03	WARRANTY CARD	TEE1	
			B46-0328-03	WARRANTY CARD	P	
			B46-0336-03	WARRANTY CARD	Y	4
			B58-0513-04	CAUTION CARD	T	
			B58-0945-03	CAUTION CARD		
			B58-0964-13	CAUTION CARD	K	
			B58-0965-13	CAUTION CARD	T	
			B58-0966-13	CAUTION CARD	ME	
			B58-0967-03	CAUTION CARD	P	
			B58-1607-03	CAUTION CARD	E1	
			B59-1104-00	SERVICE DIRECTORY	Y	
		*	B60-3706-00	INSTRUCTION MANUAL(ENG)	KPMXY	
		*	B60-3706-00	INSTRUCTION MANUAL(ENG)	TE1	
		*	B60-3707-00	INSTRUCTION MANUAL(FRN)	PE	
		*	B60-3708-00	INSTRUCTION MANUAL(G,N)	E	
		*	B60-3709-00	INSTRUCTION MANUAL(SPN)	ME1	
		*	B60-3710-00	INSTRUCTION MANUAL(TWN)	M	
		*	B60-3712-00	INSTRUCTION MANUAL(R,P,HG,CZ)	E1	
621	1D,2E		D39-0319-05	DAMPER		
Δ 626	1E		E03-0115-05	AC PLUG ADAPTER	M	
Δ 627	1D		E30-0505-05	AUDIO CORD		
Δ 628	1F		E30-2816-05	CORD WITH PLUG		
Δ 629	1F		E30-2787-05	AC POWER CORD	KP	
Δ 629	1F		E30-2788-05	AC POWER CORD	MEE1	
Δ 629	1F		E30-2789-05	AC POWER CORD	Y	
Δ 629	1F		E30-2790-05	AC POWER CORD	M	
Δ 629	1F		E30-2791-05	AC POWER CORD	T	
631	2F		E35-1381-05	FLAT CABLE		
635	1E		G01-3838-04	TORSION COIL SPRING		
636	1F		G01-3839-04	TORSION COIL SPRING		
637	2D		G02-1057-14	FLAT SPRING		
		*	H10-7440-02	POLYSTYRENE FOAMED FIXTURE	EE1	

L : Scandinavia K : USA P : Canada R : Mexico C : China I : Malaysia
Y : PX(Far East, Hawaii) T : Europe E : Europe G : Germany V : China (Shanghai) E1 : KXF-W4010E or KXF-W6010E
Y : AAFES(Europe) X : Australia Q : Russia H : Korea M : Other Areas

Δ indicates safety critical components.

* New Parts
Parts without **Parts No.** are not supplied.
Les articles non mentionnés dans le **Parts No.** ne sont pas fournis.
Teile ohne **Parts No.** werden nicht geliefert.



Ref. No	Add-ress	New Parts	Parts No.	Description	Desti-nation	Re-marks
-		*	H10-7440-02	POLYSTYRENE FOAMED FIXTURE	KPMXY	
-		*	H10-7441-02	POLYSTYRENE FOAMED FIXTURE	EE1	
-		*	H10-7441-02	POLYSTYRENE FOAMED FIXTURE	KPMXY	
-		*	H10-7442-02	POLYSTYRENE FOAMED FIXTURE	T	
-		*	H10-7443-02	POLYSTYRENE FOAMED FIXTURE	T	
-			H13-0211-14	CARTON BOARD	X	
-			H20-0568-04	PROTECTION COVER	M	
-			H25-0232-04	PROTECTION BAG (235X350X0.03)	EE1	
-			H25-0232-04	PROTECTION BAG (235X350X0.03)	KPMXY	
-			H25-0391-04	PROTECTION BAG	EE1	
-			H25-0391-04	PROTECTION BAG	KPTYX	
-			H25-0651-04	PROTECTION BAG	T	
-		*	H50-2795-04	ITEM CARTON CASE	KP	4
-		*	H50-2796-04	ITEM CARTON CASE	YXE	4
-		*	H50-2797-04	ITEM CARTON CASE	M	4
-		*	H50-2798-04	ITEM CARTON CASE	KP	6
-		*	H50-2799-04	ITEM CARTON CASE	E	6
-		*	H50-2800-04	ITEM CARTON CASE	M	6
-		*	H50-2853-04	ITEM CARTON CASE	T	4
-		*	H50-2854-04	ITEM CARTON CASE	T	6
-			H50-2927-04	ITEM CARTON CASE	E1	4
-			H50-2928-04	ITEM CARTON CASE	E1	6
641	2F		J02-1167-03	FOOT	MXTEE1	
641	2F		J02-1405-03	FOOT (D=46,H=14.5,T)	KPY	
642	2F		J19-3732-04	UNIT HOLDER		
Δ 644	1F		J42-0083-05	POWER CORD BUSHING		
-			J61-0098-05	WIRE BAND		
651	2D	*	K27-2259-04	KNOB (BUTTON)	KPY	
651	2D	*	K27-2294-04	KNOB (BUTTON)	MXTEE1	
652	2E		K29-5828-04	KNOB REC LEVEL		
653	2E	*	K29-6933-03	KNOB PLAY_STOP	KPY	
653	2E	*	K29-7328-03	KNOB PLAY_STOP	MXTEE1	
654	1E	*	K29-6932-03	KNOB 7KEY	KPY	4
654	1E	*	K29-6937-03	KNOB 10KEY	KP	6
654	1E	*	K29-7327-03	KNOB 7KEY	MXTEE1	4
654	1E	*	K29-7330-03	KNOB 10KEY	MTEE1	6
655	2D	*	K29-6935-04	KNOB EJECT L		
656	2D	*	K29-6936-04	KNOB EJECT R		
658	1E,2E	*	K29-6934-13	KNOB OPERATION	KPY	
658	1E,2E	*	K29-7329-03	KNOB OPERATION	MXTEE1	
Δ 661	2F		L07-1850-05	POWER TRANSFORMER	KP	
Δ 661	2F		L07-1851-05	POWER TRANSFORMER	MY	
Δ 661	2F		L07-1852-05	POWER TRANSFORMER	XTEE1	
RECORD/PLAYBACK(X28-2780-10)						
C1 ,2			CQ93FMG1H272J	MYLAR 2700PF	J	
C3 ,6			CE04LW1H100M	ELECTRO 10UF	50WV	
C7 ,8			CC45FSL1H221JN	CERAMIC 220PF	J	
C9 ,10			CE04LW1H100M	ELECTRO 10UF	50WV	
C11 ,12			CK45FB1H391KMM	CERAMIC 390PF	K	
C13 ,14			CK45FB1H471KMM	CERAMIC 470PF	K	6
C13 ,14			CK45FB1H681KMM	CERAMIC 680PF	K	4
C15 ,16			CE04LW1C470M	ELECTRO 47UF	16WV	
C17 ,18			CQ93FMG1H223J	MYLAR 0.022UF	J	
C19 ,20			CE04LW1H100M	ELECTRO 10UF	50WV	

L : Scandinavia K : USA P : Canada R : Mexico C : China I : Malaysia
Y : PX(Far East, Hawaii) T : Europe E : Europe G : Germany V : China (Shanghai) E1 : KXF-W4010E or KXF-W6010E
Y : AAFES(Europe) X : Australia Q : Russia H : Korea M : Other Areas

Δ indicates safety critical components.

PARTS LIST

CT-203/2050/KXF-W4010/W6010

* New Parts
 Parts without **Parts No.** are not supplied.
 Les articles non mentionnés dans le **Parts No.** ne sont pas fournis.
 Teile ohne **Parts No.** werden nicht geliefert.

③

Ref. No	Add-ress	New Parts	Parts No.	Description	Desti-nation	Re-marks
C21, 22			CE04LW1C470M	ELECTRO 47UF 16WV		
C23, 24			CK45FB1H681KMM	CERAMIC 680PF K		
C25, 26			CK45FB1H391KMM	CERAMIC 390PF K		
C27, 28			CQ93FMG1H223J	MYLAR 0.022UF J		
C29-32			CE04LW1H010M	ELECTRO 1.0UF 50WV		
C33-36			CK45FB1H332KMM	CERAMIC 3300PF K		
C37, 38			CQ93FMG1H393J	MYLAR 0.039UF J		
C39, 40			CC45FSL1H221JN	CERAMIC 220PF J		
C41-46			CE04LW1H010M	ELECTRO 1.0UF 50WV		
C47, 48			CQ93FMG1H273J	MYLAR 0.027UF J		
C49, 50			CC45FSL1H221JN	CERAMIC 220PF J		
C51-56			CQ93FMG1H222J	MYLAR 2200PF J		
C57-60			CE04LW1H0R1M	ELECTRO 0.1UF 50WV		
C61, 62			CE04LW1H100M	ELECTRO 10UF 50WV		
C63, 64			CE04LW1H0R1M	ELECTRO 0.1UF 50WV		
C65, 66			CE04LW1H2R2M	ELECTRO 2.2UF 50WV		
C67, 68			CE04LW1H010M	ELECTRO 1.0UF 50WV		
C69, 70			CE04LW1H2R2M	ELECTRO 2.2UF 50WV		
C71, 72			CE04LW1H100M	ELECTRO 10UF 50WV		
C73-77			CE04LW1H2R2M	ELECTRO 2.2UF 50WV		
C78			CC45FSL1H560JN	CERAMIC 56PF J		
C79, 80			CC45FSL1H180JN	CERAMIC 18PF J		
C81, 82			CE04LW1H0R1M	ELECTRO 0.1UF 50WV		
C83			CQ93FMG1H332J	MYLAR 3300PF J		
C84			CQ93FMG1H104J	MYLAR 0.10UF J		
C85			CE04LW1H010M	ELECTRO 1.0UF 50WV		
C86			CE04LW1C331M	ELECTRO 330UF 16WV		
C87, 88			CC45FSL1H221JN	CERAMIC 220PF J		
C89, 90			C91-1436-05	FILM 220PF J	6	
C91, 92			C91-1436-05	FILM 220PF J		
C93, 94			C91-1434-05	FILM 150PF J	4	
C93, 94			C91-1436-05	FILM 220PF J	6	
C95, 96			CK45FF1H103ZMM	CERAMIC 0.010UF Z		
C97, 98			CK45FB1H561KMM	CERAMIC 560PF K		
C99, 100			CK45FF1H223ZMM	CERAMIC 0.022UF Z		
C101, 102			CQ93FMG1H104J	MYLAR 0.10UF J		
C103			CE04LW1H100M	ELECTRO 10UF 50WV		
C104			CC45FSL2H100DN	CERAMIC 10PF D		
C105			CC45FSL2H100DN	CERAMIC 10PF D	6	
C106			CK45FF1H103ZMM	CERAMIC 0.010UF Z		
C107, 108			CQ93FMG1H562J	MYLAR 5600PF J		
C109			CK45FF1H103ZMM	CERAMIC 0.010UF Z		
C110			CE04LW1H100M	ELECTRO 10UF 50WV		
C111			CQ93HP2A103J	MYLAR 0.010UF J	6	
C112			CQ93HP2A103J	MYLAR 0.010UF J		
C113, 114			CE04LW1H100M	ELECTRO 10UF 50WV		
C115, 116			CE04LW1C470M	ELECTRO 47UF 16WV		
C117			CE04LW1C330M	ELECTRO 33UF 16WV		
C118			CE04LW1A101M	ELECTRO 100UF 10WV		
C119			CE04LW1C331M	ELECTRO 330UF 16WV		
C120			CE04LW1C101M	ELECTRO 100UF 16WV		
C121, 122			CK45FF1H223ZMM	CERAMIC 0.022UF Z		
C123			CE04LW1V332M	ELECTRO 3300UF 35WV		
C124			CE04LW1H100M	ELECTRO 10UF 50WV		
C125, 126			CE04LW1C101M	ELECTRO 100UF 16WV		

L : Scandinavia K : USA P : Canada R : Mexico C : China I : Malaysia
 Y : PX(Far East, Hawaii) T : Europe E : Europe G : Germany V : China (Shanghai) E1 : KXF-W4010E or KXF-W6010E
 Y : AAFES(Europe) X : Australia Q : Russia H : Korea M : Other Areas

△ indicates safety critical components.

* New Parts
 Parts without **Parts No.** are not supplied.
 Les articles non mentionnés dans le **Parts No.** ne sont pas fournis.
 Teile ohne **Parts No.** werden nicht geliefert.

④

Ref. No	Add-ress	New Parts	Parts No.	Description	Desti-nation	Re-marks
C127			CE04LW1H100M	ELECTRO 10UF 50WV		
C128			CE04LW1A101M	ELECTRO 100UF 10WV		
C129			CE04LW0J471M	ELECTRO 470UF 6.3WV		
C130			CE04LW1V220M	ELECTRO 22UF 35WV		
C131			CQ93FMG1H104J	MYLAR 0.10UF J		
C132			CE04LW1A101M	ELECTRO 100UF 10WV		
C133			CQ93FMG1H104J	MYLAR 0.10UF J		
C134			CE04LW1C101M	ELECTRO 100UF 16WV		
C135			CE04LW1V470M	ELECTRO 47UF 35WV		
C136			CE04DW1J101M	ELECTRO 100UF 63WV		
C137			CE04LW1J221M	ELECTRO 220UF 63WV		
C138, 139			CE04LW1H100M	ELECTRO 10UF 50WV		
C140			CE04LW1H010M	ELECTRO 1.0UF 50WV		
C141			CE04LW1A101M	ELECTRO 100UF 10WV		
C142			CQ93FMG1H473J	MYLAR 0.047UF J	6	
C143, 144			CK45FB1H102KMM	CERAMIC 1000PF K		
C145-147			CE04LW1H010M	ELECTRO 1.0UF 50WV		
C148			CK45FF1H223ZMM	CERAMIC 0.022UF Z		
C149, 150			CC45FSL1H221JN	CERAMIC 220PF J		
C151			CK45FF1H223ZMM	CERAMIC 0.022UF Z		
C152			CQ93FMG1H473J	MYLAR 0.047UF J		
C153, 154			C91-0769-05	CERAMIC 0.010UF K		
C155			CE04LW1H100M	ELECTRO 10UF 50WV		
C156			C91-0769-05	CERAMIC 0.010UF K		
△ C157			C91-1488-05	MF 6800PF 250VAC		
C158			CK45FF1H103ZMM	CERAMIC 0.010UF Z		
C161			CK45FF1H103ZMM	CERAMIC 0.010UF Z		
C162			C91-0769-05	CERAMIC 0.010UF K		
C163-165			CK45FF1H103ZMM	CERAMIC 0.010UF Z		
C166			C91-0769-05	CERAMIC 0.010UF K		
CN1			E40-4632-05	PIN ASSY		
CN2			E40-3247-05	PIN ASSY		
CN2			E40-3249-05	PIN ASSY		
CN3			E40-3249-05	PIN ASSY		
CN4			E40-4294-05	FLAT CABLE CONNECTOR		
CN5, 6			E40-4609-05	PIN ASSY		
CN7			E40-4926-05	FLAT CABLE CONNECTOR		
CN8			E40-4964-05	FLAT CABLE CONNECTOR		
CN9			E40-4811-05	PIN ASSY		
CN10			E40-0417-05	SOCKET FOR PIN ASSY		
CN11			E40-4811-05	PIN ASSY		
CN12			E40-0417-05	SOCKET FOR PIN ASSY		
CN13			E40-4294-05	FLAT CABLE CONNECTOR		
J1			E63-0136-15	PHONO JACK		
J2		*	E11-0292-05	PHONE JACK (3P)		
J3			E11-0188-05	MINIATURE PHONE JACK(2P)		
△ F1			F50-0062-05	FUSE(5X20)	KP	
-			J19-3733-03	HOLDER		
CN14, 15			J13-0075-05	FUSE CLIP	KP	
J5, 6			J11-0098-05	WIRE CLAMPER		
J8, 9			J11-0098-05	WIRE CLAMPER		
J12, 13			J11-0098-05	WIRE CLAMPER		
L1 -4			L40-1035-29	SMALL FIXED INDUCTOR(10MH, J)		

L : Scandinavia K : USA P : Canada R : Mexico C : China I : Malaysia
 Y : PX(Far East, Hawaii) T : Europe E : Europe G : Germany V : China (Shanghai) E1 : KXF-W4010E or KXF-W6010E
 Y : AAFES(Europe) X : Australia Q : Russia H : Korea M : Other Areas

△ indicates safety critical components.

PARTS LIST

CT-203/2050/KXF-W4010/W6010

* New Parts
 Parts without **Parts No.** are not supplied.
 Les articles non mentionnés dans le **Parts No.** ne sont pas fournis.
 Teile ohne **Parts No.** werden nicht geliefert.

5

Ref. No	Add-ress	New Parts	Parts No.	Description	Desti-nation	Re-marks
L5 ,6			L32-0556-05	BIAS OSCILATING COIL		
L7 ,8			L79-1209-05	LC FILTER		
L9			L32-0570-05	BIAS OSCILATING COIL		
X1			L78-0294-05	RESONATOR (10.000M)		
CP2			R90-0818-05	MULTI-COMP 47KX5 J 1/6W		
R155			RD14NB2E181J	RD 180 J 1/4W		
R177			RD14NB2E150J	RD 15 J 1/4W		
R180			RS14KB3A102J	FL-PROOF RS 1.0K J 1W		
R254			RD14NB2E150J	RD 15 J 1/4W		
R261			RD14NB2E8R2J	RD 8.2 J 1/4W	E1	
R262			RD14NB2E8R2J	RD 8.2 J 1/4W	YMXTE	
R262			RD14NB2E8R2J	RD 8.2 J 1/4W		
VR1 ,2			R12-3685-05	TRIMMING POT.(10K)		
VR3 ,4			R12-3686-05	TRIMMING POT.(22K)		
K1			S76-0018-05	MAGNETIC RELAY		6
K2			S76-0018-05	MAGNETIC RELAY		
S1			S40-1138-05	PUSH SWITCH (POWER TYPE)		
S2 -9			S70-0031-05	TACT SWITCH		6
S10			S70-0031-05	TACT SWITCH		
S11			S70-0031-05	TACT SWITCH		4
S12			S70-0031-05	TACT SWITCH		6
S13			S70-0031-05	TACT SWITCH		4
S14 ,15			S70-0031-05	TACT SWITCH		6
S16			S70-0031-05	TACT SWITCH		4
S17			S70-0031-05	TACT SWITCH		6
S18			S70-0031-05	TACT SWITCH		4
S19			S70-0031-05	TACT SWITCH		6
S20			S70-0031-05	TACT SWITCH		4
S21			S70-0031-05	TACT SWITCH		6
S22 -30			S70-0031-05	TACT SWITCH		
S31			S31-1036-05	SLIDE SWITCH		
S33			S31-2131-05	SLIDE SWITCH (POWER TYPE)	M1	
S32			T99-0546-05	ROTARY ENCODER		
D1			HSS104	DIODE		
D1			1SS133	DIODE		
D2			HSS104	DIODE		6
D2			1SS133	DIODE		6
D3			HSS104	DIODE		
D3			1SS133	DIODE		
D4			D3SBA20F03	DIODE		
D4			RBV-402LFA	DIODE		
D5 ,6			HSS104	DIODE		
D5 ,6			1SS133	DIODE		
D7			HZS6.8N(B2)	ZENER DIODE		
D7			RD6.8ES(B2)	ZENER DIODE		
D8			HZS13N(B2)	ZENER DIODE		
D8			RD13ES(B2)	ZENER DIODE		
D9			HZS5.6N(B2)	ZENER DIODE		
D9			RD5.6ES(B2)	ZENER DIODE		
D10 -12			HSS104	DIODE		
D10 -12			1SS133	DIODE		
D13			HZS3.9N(B2)	ZENER DIODE		
D13			RD3.9ES(B2)	ZENER DIODE		

L : Scandinavia K : USA P : Canada R : Mexico C : China I : Malaysia
 Y : PX(Far East, Hawaii) T : Europe E : Europe G : Germany V : China (Shanghai) E1: KXF-W4010E or KXF-W6010E
 Y : AAFES(Europe) X : Australia Q : Russia H : Korea M : Other Areas

Δ indicates safety critical components.

* New Parts
 Parts without **Parts No.** are not supplied.
 Les articles non mentionnés dans le **Parts No.** ne sont pas fournis.
 Teile ohne **Parts No.** werden nicht geliefert.

6

Ref. No	Add-ress	New Parts	Parts No.	Description	Desti-nation	Re-marks
Δ D14 -17			HSS104	DIODE		
Δ D14 -17			1SS133	DIODE		
D18			HZS20N(B)	ZENER DIODE		
D18			RD20ES(B)	ZENER DIODE		
D19			HSS104	DIODE		
D19			1SS133	DIODE		
D20			HZS5.6N(B2)	ZENER DIODE		
D20			RD5.6ES(B2)	ZENER DIODE		
D21 -30			HSS104	DIODE		
D21 -30			1SS133	DIODE		
D33 -36			HSS104	DIODE		
D33 -36			1SS133	DIODE		
D37			HZS2.7N(B2)	ZENER DIODE		
D37			RD2.7ES(B2)	ZENER DIODE		
D39 -45			HSS104	DIODE		
D39 -45			1SS133	DIODE		
D46			HSS104	DIODE		6
D46			1SS133	DIODE		6
D47 -49			HSS104	DIODE		
D47 -49			1SS133	DIODE		
D50 ,51			HSS104	DIODE		6
D50 ,51			1SS133	DIODE		6
D52			HSS104	DIODE		4
D52			1SS133	DIODE		4
D53			HSS104	DIODE		6
D53			1SS133	DIODE		6
D54 -65			HSS104	DIODE		
D54 -65			1SS133	DIODE		
D66			HSS104	DIODE		6
D66			1SS133	DIODE		6
D67 -77			HSS104	DIODE		
D67 -77			1SS133	DIODE		
D78			HSS104	DIODE		4
D78			1SS133	DIODE		4
D78			1SS199	DIODE		6
D79			1SS199	DIODE		
D80 ,81			HSS104	DIODE		
D80 ,81			1SS133	DIODE		
ED1			FIP6AMW6	INDICATOR TUBE		
IC1			CXP82540-136Q	MI-COM IC		
IC2			HA12167FB	IC(DOLBY B/C, REC EQ)		
IC3			UPC1297CA	ANALOGUE IC		
IC4 ,5			TA8125S	IC(2CH PRE AMP)		
IC6			BA10393	ANALOGUE IC		
IC7			NJM4558D	ANALOGUE IC		
Δ IC8			S-806D-Z	ANALOGUE IC		
IC9			BA17812T	IC(VOLTAGE REGULATOR/ +12V)		
IC9			UPC7812AHF	IC(VOLTAGE REGULATOR/ +12V)		
IC10			XL24C01AP	MEMORY IC		
Q1 -4			2SD1450(S,T)	TRANSISTOR		
Q5 -12			DTC124ES	DIGITAL TRANSISTOR		
Q5 -12			UN4212	DIGITAL TRANSISTOR		
Q13 ,14			2SC2458(Y,GR)	TRANSISTOR		
Q13 ,14			2SC3311A(Q,R)	TRANSISTOR		
Q15 ,16			2SD1450(S,T)	TRANSISTOR		

L : Scandinavia K : USA P : Canada R : Mexico C : China I : Malaysia
 Y : PX(Far East, Hawaii) T : Europe E : Europe G : Germany V : China (Shanghai) E1: KXF-W4010E or KXF-W6010E
 Y : AAFES(Europe) X : Australia Q : Russia H : Korea M : Other Areas

Δ indicates safety critical components.

PARTS LIST

* New Parts

Parts without **Parts No.** are not supplied.

Les articles non mentionnés dans le **Parts No.** ne sont pas fournis.

Teile ohne **Parts No.** werden nicht geliefert.

7

Ref. No	Add-ress	New Parts	Parts No.	Description	Desti-nation	Re-marks
Q17, 18			2SC2458(Y,GR)	TRANSISTOR		
Q17, 18			2SC3311A(Q,R)	TRANSISTOR		
Q19, 20			DTC124ES	DIGITAL TRANSISTOR		
Q19, 20			UN4212	DIGITAL TRANSISTOR		
Q21			2SC2458(Y,GR)	TRANSISTOR		
Q21			2SC3311A(Q,R)	TRANSISTOR		
Q22			DTC124ES	DIGITAL TRANSISTOR		
Q22			UN4212	DIGITAL TRANSISTOR		
Q23 -25			DTA124ES	DIGITAL TRANSISTOR		
Q23 -25			UN4112	DIGITAL TRANSISTOR		
Q26 -28			DTC124ES	DIGITAL TRANSISTOR		
Q26 -28			UN4212	DIGITAL TRANSISTOR		
Q29 -36			2SC1845(F,E)	TRANSISTOR	6	
Q37 -40			2SC2003(L,K)	TRANSISTOR	6	
Q41, 42			2SA992(F,E)	TRANSISTOR	6	
Q43, 44			DTC124ES	DIGITAL TRANSISTOR	6	
Q43, 44			UN4212	DIGITAL TRANSISTOR	6	
Q45, 46			2SC2458(Y,GR)	TRANSISTOR		
Q45, 46			2SC3311A(Q,R)	TRANSISTOR		
Q47			2SA1534A(R,S)	TRANSISTOR		
Q48			DTC124ES	DIGITAL TRANSISTOR		
Q48			UN4212	DIGITAL TRANSISTOR		
Q49			DTC124ES	DIGITAL TRANSISTOR	6	
Q49			UN4212	DIGITAL TRANSISTOR	6	
Q50			DTC124ES	DIGITAL TRANSISTOR		
Q50			UN4212	DIGITAL TRANSISTOR		
Q51, 52			2SC1845(F,E)	TRANSISTOR		
Q53			DTC124ES	DIGITAL TRANSISTOR		
Q53			UN4212	DIGITAL TRANSISTOR		
Q54			2SC1845(F,E)	TRANSISTOR		
Q55			2SD2374	TRANSISTOR		
Q56			2SC3246	TRANSISTOR		
Q57			2SA1535A	TRANSISTOR		
Q58			2SC2458(Y,GR)	TRANSISTOR		
Q58			2SC3311A(Q,R)	TRANSISTOR		
Q59, 60			2SC3246	TRANSISTOR		
Q61, 62			2SA1048(Y,GR)	TRANSISTOR		
Q61, 62			2SA1309A(Q,R)	TRANSISTOR		
Q63, 64			2SC3246	TRANSISTOR		
Q65 -68			DTC124ES	DIGITAL TRANSISTOR		
Q65 -68			UN4212	DIGITAL TRANSISTOR		
MECHANISM (D40-1450-05/1461-05/1473-05)						
401	2A		A10-3178-08	HEAD CHASSIS		
403	1C,2C		B30-2409-08	LED SEL2415E		
405	2C		D01-0175-08	FLYWHEEL (R) ASSY		
406	1B		D01-0176-08	FLYWHEEL (L) ASSY		
409	1C		D10-3470-08	SHIFT LEVER		
410	2C		D10-3471-18	HEAD CHANGE ARM		
411	1C		D13-1622-18	CAM GEAR		
412	1A		D10-3500-08	EJECT LEVER (L) (B MECHA)		
413	2C		D10-3501-08	EJECT LEVER (R) (A MECHA)		
414	2A		D10-3478-08	SELET LEVER		
415	1B		D10-3479-08	CHASSIS OS ASSY		

L : Scandinavia K : USA P : Canada R : Mexico C : China I : Malaysia
 Y : PX(Far East, Hawaii) T : Europe E : Europe G : Germany V : China (Shanghai) D40-1450-05: CT-2050(KXF-W6010) A-DECK
 Y : AAFES(Europe) X : Australia Q : Russia H : Korea M : Other Areas D40-1451-05: CT-203(KXF-W4010) A-DECK
 D40-1473-05: B-DECK

△ indicates safety critical components.

* New Parts

Parts without **Parts No.** are not supplied.

Les articles non mentionnés dans le **Parts No.** ne sont pas fournis.

Teile ohne **Parts No.** werden nicht geliefert.

8

Ref. No	Add-ress	New Parts	Parts No.	Description	Desti-nation	Re-marks
416	2A		D10-3480-08	C/R LEVER		
417	1A		D10-3502-08	ARM (LEFT) (INTER LOCK)		
418	2B		D10-3503-08	ARM (RIGHT) (INTER LOCK)		
420	2A		D13-0981-08	ROTATION GEAR		
421	1A		D13-1616-08	REW GEAR		
422	1A,2B		D13-1617-08	REEL GEAR		
423	1B		D13-1618-08	IDLER GEAR		
424	2A		D13-1621-08	RETURN GEAR		
425	1C		D10-3470-08	TRIGGER ARM		
426	2B		D14-0367-08	PINCH ARM (R) ASSY		
427	2A		D14-0368-08	PINCH ARM (L) ASSY		
430	1B		D15-0369-08	IDLER PULLEY		
431	2C		D16-0375-08	DRIVE BELT		
432	2C		D16-0376-08	CLUTCH BELT		
433	1A,2A		D19-0270-18	REEL CAP (A)		
434	1B		D19-0287-18	CLUTCH ARM ASSY		
444	2B		G01-3707-18	SPRING (R) (A MECHA)		
463	2A		G02-1043-08	AZIMUTH SPR		
439	1C		E35-0934-08	15P FLAT RIBBON WIRE (A MECHA)		
440	1C		E35-0358-08	15P FLAT RIBBON WIRE (B MECHA)		
441	2A		E35-1005-08	3P HEAD WIRE ASSY (A MECHA)		4
441	2A		E35-1006-08	5P HEAD WIRE ASSY (B MECHA)		
441	2A		E35-1189-08	5P HEAD WIRE ASSY (A MECHA)		6
442	1C		E35-0986-08	MOTOR WIRE		
443	1A		G01-3706-08	SPRING (L) (B MECHA)		
445	1A,2B		G01-3709-08	B.T SPRING		
446	1B		G01-3710-08	SHIFT LEVER SP		
447	1C		G01-3711-08	TRIGGER ARM SP		
448	2C		G01-3712-08	HEAD CHANGE ARM SP		
449	1A,2C		G01-3708-08	EJECT SP		
450	2A		G01-3714-08	C/R LEVER SP		
451	2A		G01-3715-08	SELECT SP		
452	2A		G01-3716-08	SHIFT SP		
455	2A		G01-3718-08	RETURN SPR		
456	2A		G01-3719-08	FWD SPR		
457	2A		G01-3720-08	HEAD RETURN PLATE SP		
458	2B		G01-3721-08	BRAKE SP (R)		
459	1B		G01-3722-08	BRAKE SP (L)		
460	1B		G01-3724-08	CLUTCH ARM SPRING (B)		
461	1B		G01-3725-08	CLUTCH SP		
462	1B		G02-0913-08	PACK SPRING		
465	2A		G11-2117-08	HEAD WIRE CLAMP		
466	1B		G11-2205-08	TUBE		
467	2B		G16-0791-08	REFLECT SEAL		
468	2A		G01-3739-08	HEAD CHASSIS SP		
470	1C		J19-3652-08	CABLE HOLDER		
471	2A		J19-3709-08	HEAD BASE		
472	2A		J21-6135-08	HEAD RETURN PLATE		
473	2A		J21-6199-08	HEAD PLATE ASSY		
474	2A		J42-0183-08	REEL BUSH		
475	2B		J69-0086-08	FILAMENT TAPE		
476	1A		J21-6178-08	BRACKET (L) (B MECHA)		
477	2C		J21-6179-08	BRACKET (R) (A MECHA)		

L : Scandinavia K : USA P : Canada R : Mexico C : China I : Malaysia
 Y : PX(Far East, Hawaii) T : Europe E : Europe G : Germany V : China (Shanghai) D40-1450-05: CT-2050(KXF-W6010) A-DECK
 Y : AAFES(Europe) X : Australia Q : Russia H : Korea M : Other Areas D40-1451-05: CT-203(KXF-W4010) A-DECK
 D40-1473-05: B-DECK

△ indicates safety critical components.

PARTS LIST

CT-203/2050/KXF-W4010/W6010

* New Parts
 Parts without **Parts No.** are not supplied.
 Les articles non mentionnés dans le **Parts No.** ne sont pas fournis.
 Teile ohne **Parts No.** werden nicht geliefert.



Ref. No	Add-ress	New Parts	Parts No.	Description	Desti-nation	Re-marks
478	1A,2C		J31-0851-08	EJECT COLLAR		
AA			N19-1316-08	POLY WASHER		
AB			N19-1354-08	NYLON WASHER		
AC			N19-1355-08	NYLON WASHER		
AD			N19-1384-08	POLY WASHER		
AE			N19-1385-08	POLY WASHER		
AF			N19-1386-08	POLY WASHER		
AG			N19-1387-08	TEFRON WASHER		
AH			N19-1388-08	POLY WASHER		
AK			N09-2900-08	SCREW		
S			N09-1497-08	TAP TITE SCREW		
T			N09-2871-08	TAPPING SCREW		
V			N09-2876-08	HEAD SCREW		
W			N09-2901-08	BIND TAP TITE SCREW		
X			N09-3112-08	AZIMUTH SCREW		
XA			N09-3135-08	BIND TAP TITE SCREW 2.6*6		
Y			N19-1287-08	POLY WASHER		
Z			N19-1288-08	POLY WASHER		
480	1C,2C		S74-0033-08	REC SWITCH		
481	1C,2C		S74-0042-08	PLAY SWITCH		
484	1C		T94-0233-08	SOLENOID ASSY		
485	1C,2C		T95-0125-08	PHOTO INTERRUPTER		
MM	1C		T42-0687-08	MOTOR ASSY		
PH	1A		T31-0072-08	ROTATION HD(PB)KP-7442-CS-8352		4A
RPEH	2A		T39-0027-08	ROTATION HD(RP)KC-9242-CB-8354		6
RPEH	2A		T39-0027-08	ROTATION HD(RP)KC-9242-CB-8354		4B

L : Scandinavia K : USA P : Canada R : Mexico C : China I : Malaysia
 Y : PX(Far East, Hawaii) T : Europe E : Europe G : Germany V : China (Shanghai) D40-1450-05: CT-2050(KXF-W6010) A-DECK
 Y : AAFES(Europe) X : Australia Q : Russia H : Korea M : Other Areas D40-1451-05: CT-203(KXF-W4010) A-DECK
 D40-1473-05: B-DECK

▲ indicates safety critical components.

HOW TO READ THE PARTS LIST.

There are abbreviation in the parts list.

MODEL	ABB	DESTINATIONS
CT-203	4	K,P
KXF-W4010	4	Y,M,X,T,E
KXF-W4010E	4	E1
CT-2050	6	K,P
KXF-W6010	6	M,T,E
KXF-W6010E	6	E1

CT-203/2050/KXF-W4010/W6010

SPECIFICATIONS

[MODEL: CT-2050/KXF-W6010]

Track System	4 track, 2 channel stereo	
Recording System	AC bias (Frequency: 105 kHz)	
Heads	A DECK Playback/recording heads ..1 Erasing head	1
	B DECK Playback/recording heads ..1 Erasing head	1
Motors.....	A DECK.....DC motor x 1 B DECK.....DC motor x 1	
Wow and Flutter	±0.17 % (IEC) ±0.28 % (DIN) 0.1 % (W.R.M.S)	
Fast Winding Time	Approx. 110 seconds (C-60 tape)	
Frequency Response		
TYPE I tape	30 Hz to 18,000 Hz, ±3 dB	
TYPE II tape	30 Hz to 19,000 Hz, ±3 dB	
Signal to Noise Ratio		
Dolby NR OFF.....	56 dB (IEC, 250 nWb/m, TYPE II tape)	
Dolby NR OFF.....	59 dB	
Dolby B NR ON	68 dB	
Dolby C NR ON.....	75 dB (3rd, H.D., 3 %, TYPE II tape)	
Harmonic Distortion.....	Less than 1.2 % (at 315 Hz, 3rd H.D., 250 nWb/m, TYPE II tape)	
Input sensitivity/Impedance		
LINE IN.....	122.8 mV/47 kΩ	
Output Level/Impedance		
LINE OUT	775 mV/1.0 kΩ	
Headphones	0.5 mW/32 Ω	

[General]

Power Consumption	30W
Dimensions.....	W : 440 mm (15-3/4") H : 134 mm (5-9/16") D : 367 mm (15-3/8")
Weight (Net)	4.6 kg (10.6 lb)

[MODEL: CT-203/KXF-W4010]

Track System	4 track, 2 channel stereo	
Recording System	AC bias (Frequency: 105 kHz)	
Heads	A DECK Playback head	1
	B DECK Playback/recording heads ..1 Erasing head.....	1
Motors	A DECK.....DC motor x 1 B DECK.....DC motor x 1	
Wow and Flutter	±0.17 % (IEC) ±0.28 % (DIN) 0.1 % (W.R.M.S)	
Fast Winding Time	Approx. 110 seconds (C-60 tape)	
Frequency Response		
TYPE I tape	30 Hz to 18,000 Hz, ±3 dB	
TYPE II tape	30 Hz to 19,000 Hz, ±3 dB	
Signal to Noise Ratio		
Dolby NR OFF.....	56 dB (IEC, 250 nWb/m, TYPE II tape)	
Dolby NR OFF.....	59 dB	
Dolby B NR ON	68 dB	
Dolby C NR ON.....	75 dB (3rd, H.D., 3 %, TYPE II tape)	
Harmonic Distortion.....	Less than 1.2 % (at 315 Hz, 3rd H.D., 250 nWb/m, TYPE II tape)	
Input sensitivity/Impedance		
LINE IN.....	122.8 mV/47 kΩ	
Output Level/Impedance		
LINE OUT	775 mV/1.0 kΩ	
Headphones	0.5 mW/32 Ω	

[General]

Power Consumption	30 W
Dimensions.....	W : 440 mm (15-3/4") H : 134 mm (5-9/16") D : 367 mm (15-3/8")
Weight (Net)	4.6 kg (10.6 lb)

KENWOOD follows a policy of continuous advancements in development. For this reason specifications may be changed without notice.

CT-203/2050/KXF-W4010/W6010

KENWOOD CORPORATION

14-6,Dogenzaka 1-chome, Shibuya-ku, Tokyo, 150 Japan

KENWOOD SERVICE CORPORATION

P.O BOX 22745, 2201 East Dominguez St., Long Beach, CA 90801-5745, U.S.A.

KENWOOD ELECTRONICS CANADA INC.

6070 Kestrel Road, Mississauga, Ontario, Canada L5T 1S8

KENWOOD ELECTRONICS LATIN AMERICA S.A.

P.O BOX 55-2791, Piso 6 plaza Chase, Cl. 47 y Aquilino de la Guardia Panama, Republic de Panama

KENWOOD ELECTRONICS BRASIL LTDA.

Av Indianópolis, 628, 04062-001 Planalto Paulista São Paulo-SP-Brasil

KENWOOD ELECTRONICS U.K. LIMITED

KENWOOD House, Dwight Road, Watford, Herts., WD1 8EB., United Kingdom

KENWOOD ELECTRONICS BELGUM N.V.

Meachelsesteenweg 418, B-1930 Zaventem, Belgium

KENWOOD ELECTRONICS DEUTSCHLAND GMBH

Rembrücker Str. 15, 63150 Heusenstamm, Germany

KENWOOD ELECTRONICS FRANCE S.A.

13 Boulevard Ney, 75018 Paris, France

Note:

Component and circuit are subject to modification to insure best operation under differing local conditions. This manual is based on Europe (E) standard, and provides information on regional circuit modification through use of alternate schematic diagrams, and information on regional component variations through use of parts list.

KENWOOD ELECTRONICS ITALIA S.p.A.

Via G. Sirtori, 7/9 20129, Milano, Italy

KENWOOD IBÉRICA S.A.

Bolivia, 239-08020 Barcelona, Spain

KENWOOD ELECTRONICS AUSTRALIA PTY. LTD.

(A.C.N. 001499 074)

P.O Box 504, 8 Figtree Drive, Australia Centre, Homebush, N.S.W. 2140, Australia

KENWOOD & LEE ELECTRONICS, LTD.

Unit 3712-3724, Level 37, Tower 1, Metroplaza, 223 Hing Fong Road, Kwai Fong N.T., Hong Kong

KENWOOD ELECTRONICS GULF FZE

P.O.Box 61318, Jebel Ali, Dubai, U.A.E.

KENWOOD ELECTRONICS SINGAPORE PTE LTD.

No. 1 Genting Lane #02-02, KENWOOD Building, Singapore, 349544

KENWOOD ELECTRONICS (MALAYSIA) SDN BHD.

#4.01 Level 4, Wisma Academy Lot 4A, Jalan 19/1 46300 Petaling Jaya Selangor Darul Ehsan Malaysia

KENWOOD ELECTRONICS (THAILAND) CO., LTD.

573/111 Soi Ramkhamhaeng 39, Ramkhamhaeng Road, Wangthonglang, Bangkok, Bangkok 10301 Thailand