

STEREO DOUBLE CASSETTE DECK

KX-W8040

SERVICE MANUAL

KENWOOD

©1991-11 PRINTED IN JAPAN
B51-4467-00 (S) 4134

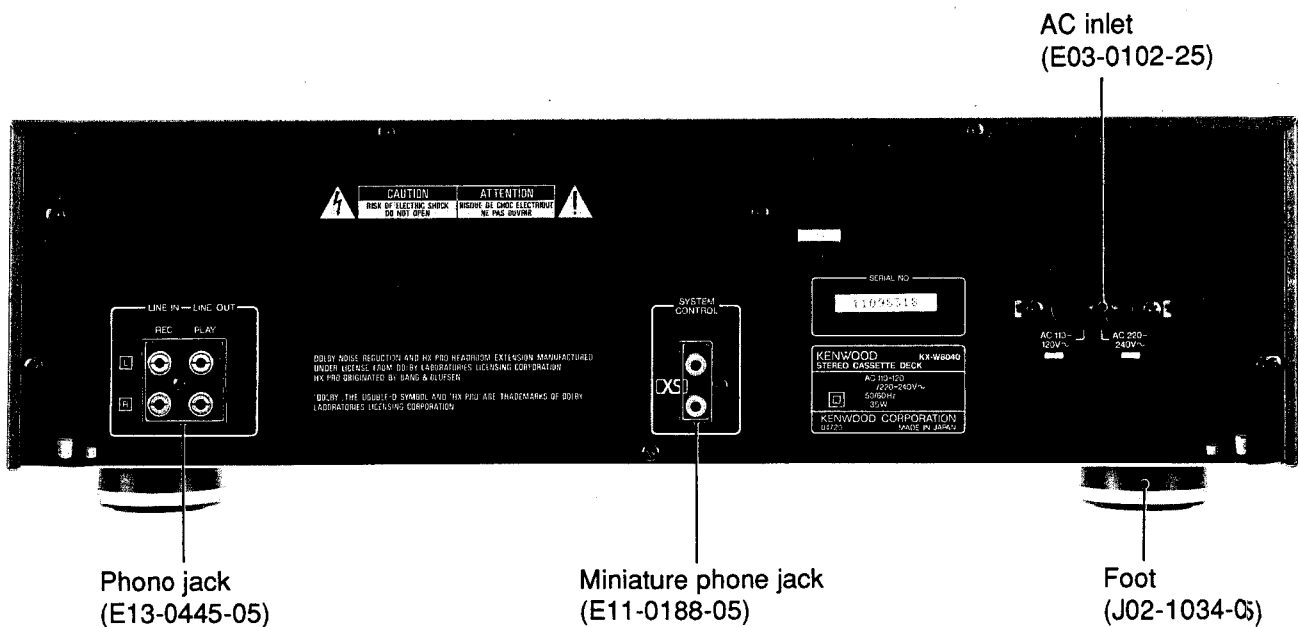
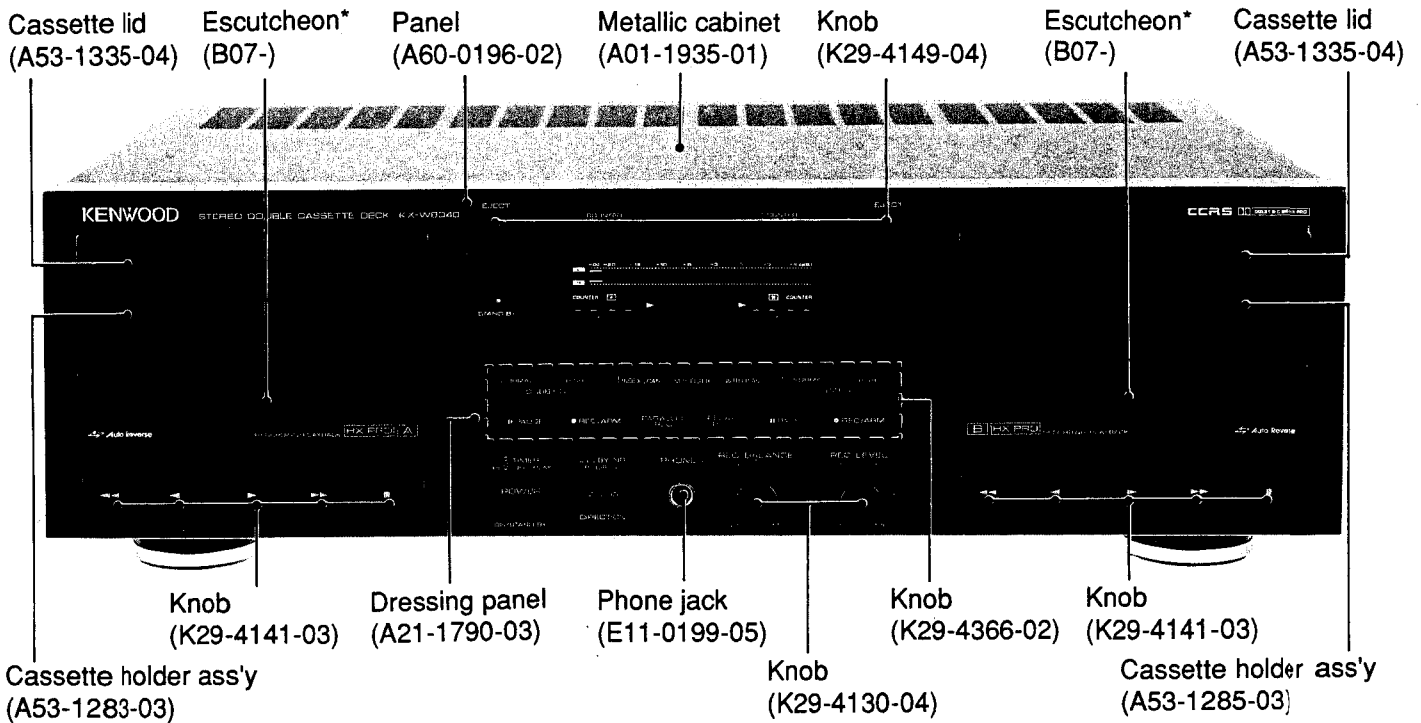

* Refer to parts list on page 29.
Photo is KX-W8040Y type.

KX-W8040

CONTENTS

DISASSEMBLY FOR REPAIR	3	PC BOARD	19
BLOCK DIAGRAM	4	SCHEMATIC DIAGRAM	21
CIRCUIT DESCRIPTION	5	EXPLODED VIEW (MECHANISM)	27
ADJUSTMENT	14	EXPLODED VIEW (UNIT)	28
REGLAGE	15	PART LIST	29
ABGLEICH	16	SPECIFICATIONS	BACK COVER
WIRING DIAGRAM	18		

Accessories

Audio cord 2
(E30-0505-05)

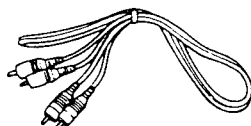

System control cord 1
(E30-1392-05)

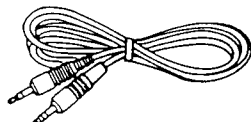

AC cord 1
(Except for some areas.)
(The shape may vary depending on the destination area.) (E30-1305-15:Y)
(E30-1329-05:M)



AC plug adaptor 1
(Except for some areas.)
For the unit with a European AC plug in areas other than Europe. (E03-0115-05)

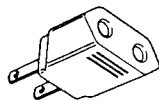

Instruction manual

B60-0777-00 (English)

B60-0778-00 (French) P, E

B60-0779-00 (Chinese) M

B60-0780-00 (GE, Du, It) E

B60-0830-00 (Spanish) M

Item carton case

H50-0271-04

Polystyren formd fixture

H10-5101-12

H10-5102-12

DISASSEMBLY FOR REPAIR

1. How to remove the front panel

- ① Press the EJECT button to open the cassette holder then remove the cassette lid.
Two claws of escutcheon pulling out side then remove the escutcheon. (same of both deck)
- ② Remove the four screws of bottom (❶)

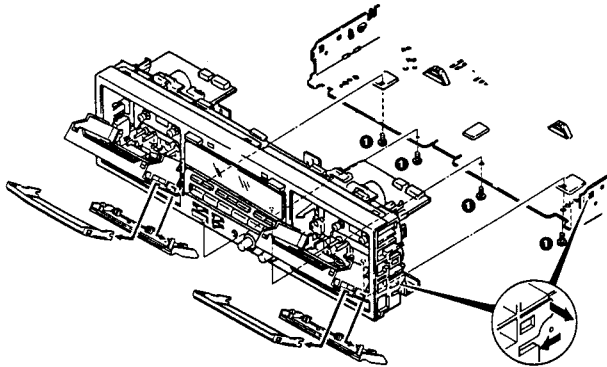

2. How to remove the mechanism

- ① Remove the four screws (❷) fixing the mechanism assembly

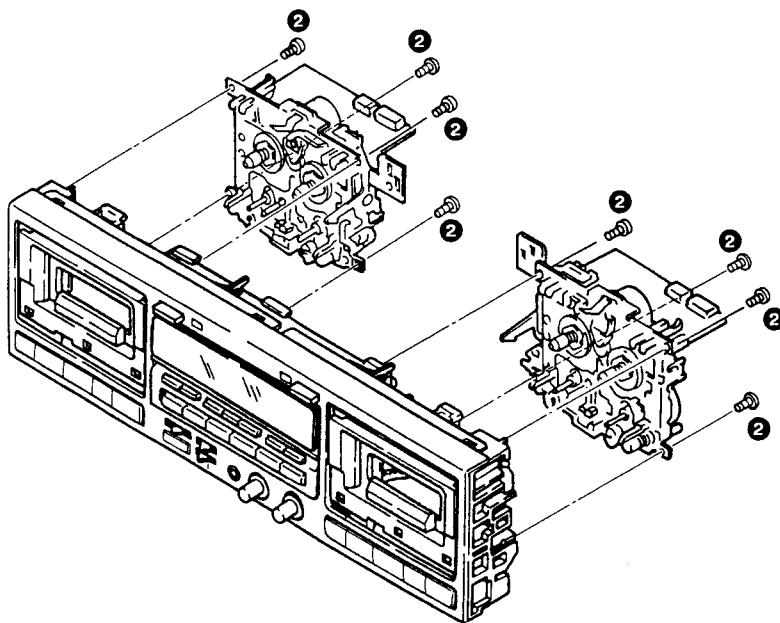

KX-W8040

BLOCK DIAGRAM

BLOCK & LEVEL DIAGRAM

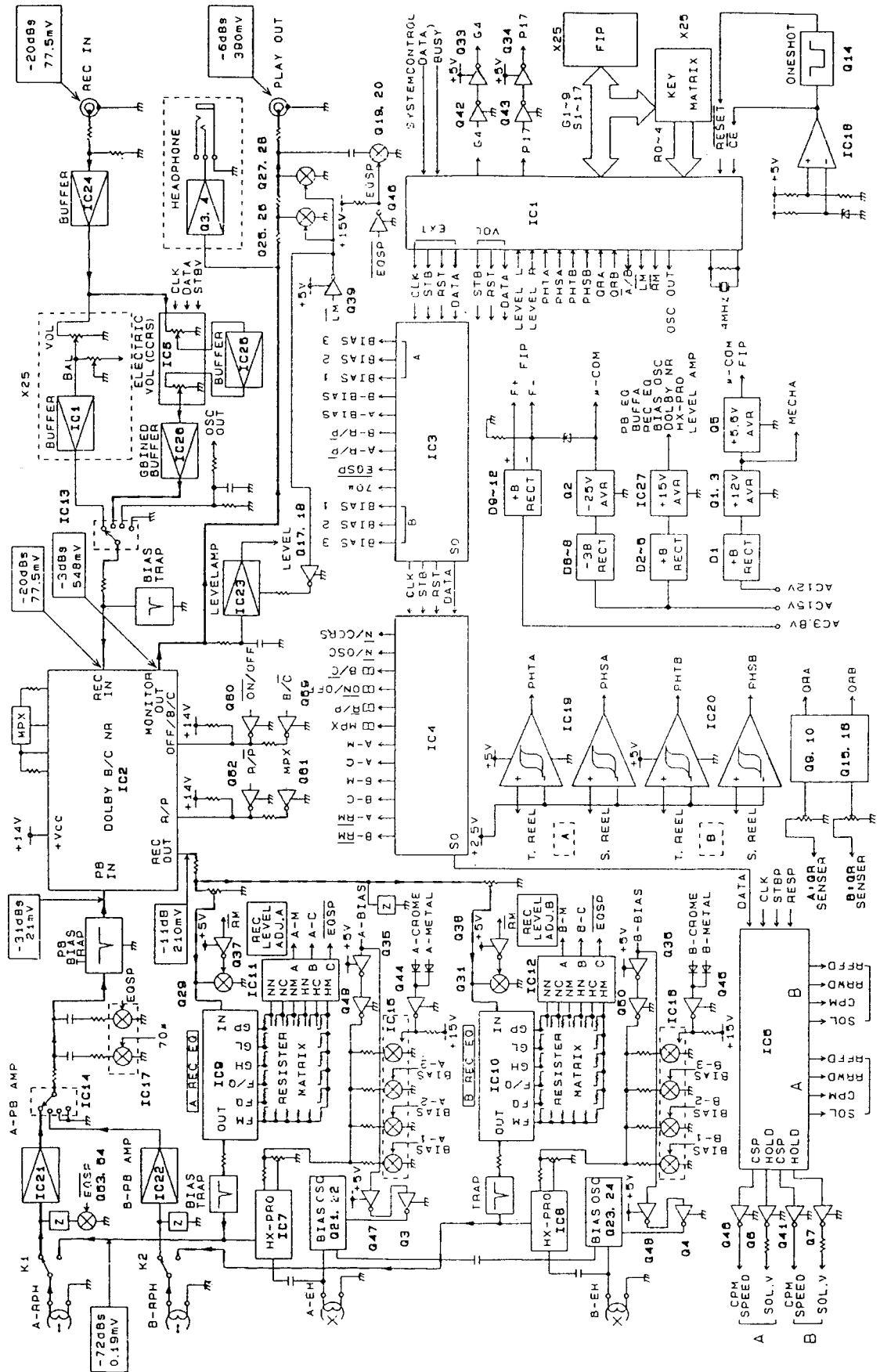

CIRCUIT DESCRIPTION

RECORD/PLAYBACK AMPLIFIER UNIT (X28-2310-10)

Parts Description

Ref. No.	Parts Name	Use/Function	Operation/Condition/Interchangeability
Q1	2SD1266(Q, P)	+12V AVR	
Q2	2SA999(E, F)	-22V AVR	
Q3	2SC3940A	BIAS OSC CONTROL (A)	Controlled by Q47 ON: A REC
Q4	2SC3940A	BIAS OSC CONTROL (B)	Controlled by Q48 ON: B REC
Q5	2SC3940A	+5.6V AVR	
Q6	2SC3246	MECHA(A) SOL CONT.	Controlled by IC5 pin 2 ON: Mechanism A runs
Q7	2SC3246	MECHA(B) SOL CONT.	Controlled by IC5 pin 8 ON: Mechanism B runs
Q9,10,15,16	2SA933S(Q,R)	QUICK REV. AMP	Controlled by Q5. Detects the end of tape
Q11, 12	2SA933S(Q,R)	LEVEL AMP LIMITTER	Controlled by Q5. Since the level amplifier output to +5V.
Q13	2SC1740S(Q,R)	+12V AVR	
Q14	2SA933S(Q,R)	POWER ON RESET	Controlled by IC18 pin 7. Turns on momentarily when the power is switched on.
Q17, 18	2SA933S(Q,R)	LEVEL AMP TIME	Controlled by Q39 ON: Quick search
Q19,20	2SA933S(Q,R)	HIGH DUBBING MUTING	Controlled by Q46 ON: High-speed dubbing
Q21, 22	2SA933S(Q,R)	A-EH BIAS OSC	Controlled by Q3
Q23, 24	2SA933S(Q,R)	B-EH BIAS OSC	Controlled by Q4
Q25~28	2SA933S(Q,R)	PLAY OUT MUTING	Controlled by Q39
Q39, 30	2SA933S(Q,R)	A-REC MUTING	Controlled by Q37 OFF: A REC
Q31, 32	2SA933S(Q,R)	B-REC MUTING	Controlled by Q38 OFF: B REC
Q33, 34	DTA124ES	FL DRIVER	Controlled by Q42 and Q43
Q35	DTA124ES	A-BIAS CONTROL	Controlled by IC3 pin 5 OFF: A REC
Q36	DTA124ES	B-BIAS CONTROL	Controlled by IC3 pin 4 OFF: B REC
Q37	DTA124ES	A-REC MUTING DRIVER	Controlled by IC4 pin 12 OFF: A REC
Q38	DTA124ES	B-REC MUTING DRIVER	Controlled by IC4 pin 13 OFF: B REC
Q39	DTA124ES	PLAY OUT MUTING DRIVER	Controlled by IC1 pin 14
Q40	DTC124ES	A-CPM SPEED CONTROL	Controlled by IC5 pin 4 OFF: High speed
Q41	DTC124ES	B-CPM SPEED CONTROL	Controlled by IC5 pin 13 OFF: High speed
Q42, 43	DTC124ES	FL, DRIVER	Controlled by IC1 pins 10 and 11
Q44	DTC124ES	A-NORMAL BIAS CONTROL	Controlled by IC4 pins 7 and 2 OFF: A Normal
Q45	DTC124ES	B-NORMAL BIAS CONTROL	Controlled by IC4 pins 9 and 11 OFF: B Normal
Q46	DTC124ES	HIGH-DUBB MUTING DRIVER	Controlled by IC3 pin 8 OFF: High speed only
Q47	DTC124ES	A-EH BIAS OSC CONTROL	Controlled by Q35 OFF: A REC
Q48	DTC124ES	B-EH BIAS OSC CONTROL	Controlled by Q36 OFF: B REC
Q49	DTC124ES	A-BIAS(HX) CONTROL	Controlled by Q35 OFF: A REC
Q50	DTC124ES	B-BIAS (HX) CONTROL	Controlled by Q36 OFF: B REC
Q51	DTC124ES	A-HEAD R/P CONTROL	Controlled by IC3 pin 7 ON: A REC
Q52	DTC124ES	B-HEAD R/P CONTROL	Controlled by IC3 pin 6 ON: A REC
Q52, 54	DTC124ES	HIGH SPEED HEAD EQ	Controlled by IC3 pin 8 OFF: High speed only
Q55	DTC124ES	P.B EQ A/B SW	Controlled by IC1 pin 13 OFF: A playback
Q56	DTC124ES	P.B EQ R/P SW	Controlled by IC4 pin 5 OFF: Recording
Q57	DTC124ES	NOR/CCRS SW	Controlled by IC4 pin 1 ON: CCRS only
Q58	DTC124ES	NOR/OSC SW	Controlled by IC4 pin 2 ON: Auto bias recording
Q59	DTC124ES	DOLBY ON/OFF SW	Controlled by IC4 pin 4 ON: Dolby off
Q60	DTC124ES	DOLBY B/C SW	Controlled by IC4 pin 3 ON: Dolby B
Q61	DTC124ES	MPX ON OFF SW	Controlled by IC4 pin 6 ON: Multiplex filter on
Q62	DTC124ES	DOLBY R/P SW	Controlled by IC4 pin 5 ON: Dolby playback

KX-W8040

CIRCUIT DESCRIPTION

RECORD/PLAYBACK AMPLIFIER UNIT (X28-2310-10)

Parts No.	Parts Name	Use/Function	Operation/Condition/Interchangeability
IC1	M50945-129SP	Microprocessor	
IC2	HA12170NT	Dolby IC	
IC3~5	CXD1067P	Extended I/O	
IC6	TC9213P	Electronic volume control	
IC7, 8	UPC1297CA	Dolby HX-PRO	
IC9, 10	CXA1198SP	REC EQ	
IC11, 12	TC4051BP	REC EQ SW	
IC13	TC4052BP	Input SW	
IC14	TC4052BP	P.B A/B SW	
IC15	TD62554S	A-AUTO BIAS SW	
IC16	TD62554S	B-AUTO BIAS SW	
IC17	TD62554S	EQ SW	
IC18	BA10393	C, E	
IC19	BA10393	A-REEL COMP.	
IC20	BA10393	B-REEL COMP.	
IC21	TA8125S	A-P.B EQ	
IC22	TA8125S	B-P.B EQ	
IC23	NJM4558D	LEVEL AMP	
IC24	NJM4565D-D	Input Buffer	
IC25, 26	NJM4565D-D	Electronic volume control Buffer	
IC27	μPC7815HF	+15V AVR	

CIRCUIT DESCRIPTION

Micro processor (M50945-129SP)

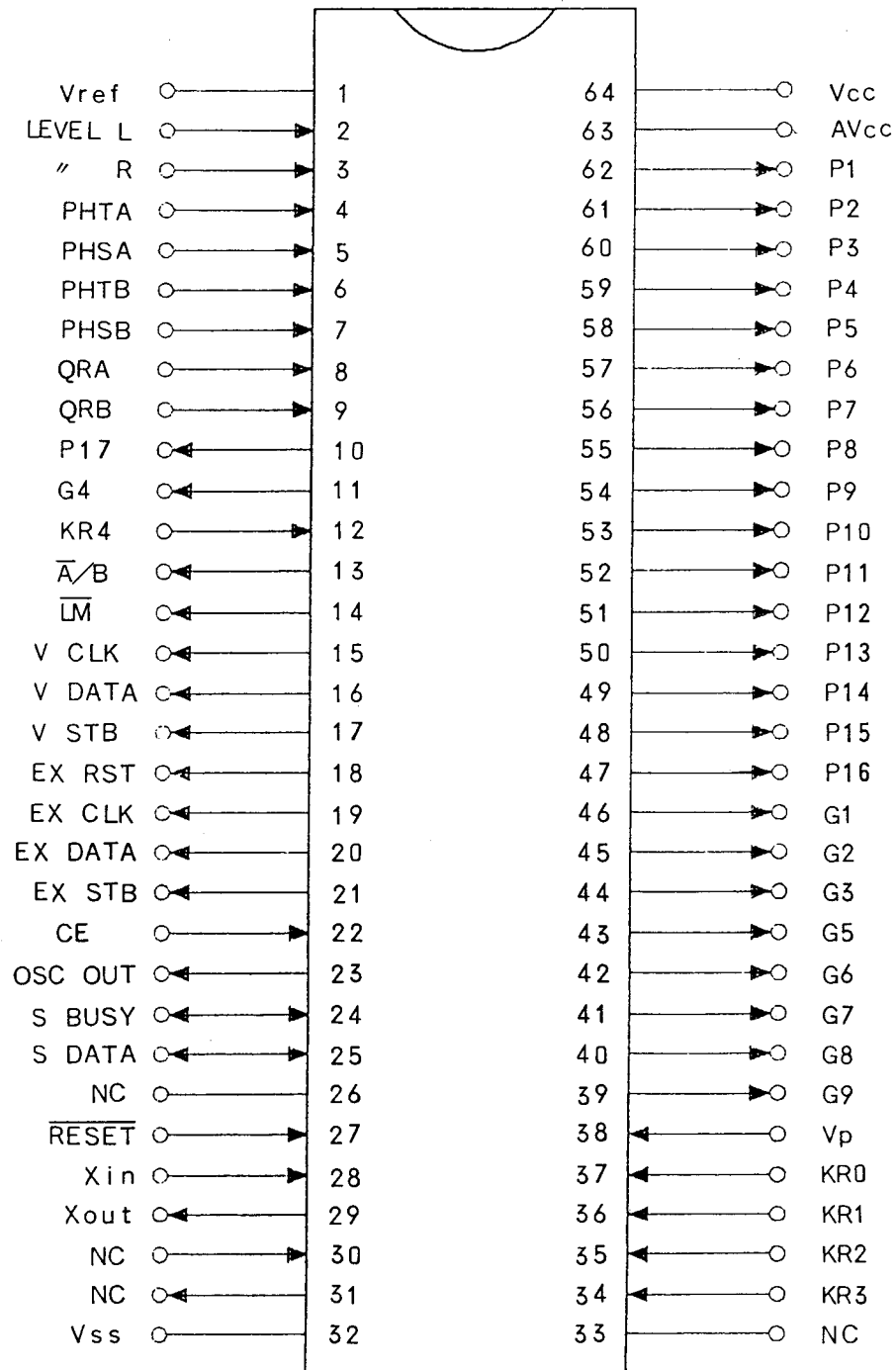

KX-W8040

CIRCUIT DESCRIPTION

Pin Description

Pin No.	I/O	Name	Function
1	-	VREF	Analog-to-digital converter reference voltage
2	I	LEVEL L	Left-channel signal input
3	I	LEVEL R	Right-channel signal input
4	I	PHTA	Mechanism A takeup hub sensor input
5	I	PHSA	Mechanism A supply hub sensor input
6	I	PHTB	Mechanism B takeup hub sensor input
7	I	PHSB	Mechanism B supply hub sensor input
8	I	QRA	Mechanism A quick-reverse sensor input
9	I	QRB	Mechanism B quick-reverse sensor input
10	O	Sq	Fluorescent segment output q
11	O	P17	Fluorescent grid output 4G
12	I	KR4	Key input H: KEY ON L: KEY OFF
13	O	A/B	A/B switching output H: B deck L: A deck
14	O	L. MUTE	Line mute output H: MUTE OFF L: MUTE ON
15	O	VCLK	Electronic volume control clock output
16	O	VDT	Electronic volume control data output
17	O	VST	Electronic volume control strobe output
18	O	EXRST	Extended IC reset output H: Normal L: Reset
19	O	EXCLK	Extended IC clock output
20	O	EXDATA	Extended IC data output
21	O	EXST	Extended IC strobe output
22	I	CE	AC off detection H: AC ON L: AC OFF
23	O	OSC	400-Hz/10-kHz output for auto-bias
24	I/O	SBUSY	Serial busy input/output
25	I/O	SDATA	Serial data input/output
26	-	Vss	Connect to ground
27	I	RESET	Reset input H: Normal L: Reset
28	I	XIN	4-MHz ceramic-lock connection input
29	O	XOUT	4-MHz ceramic-lock connection input
30	I	XCIN	Connect to GND. Pin for clock pulses for time display
31	O	XCOUT	OPEN. Pin for clock pulses for time display
32	-	Vss	Ground pin
33	O	NC	OPEN
34	I	KR3	Key input H: KEY ON L: KEY OFF
35	I	KR2	Key input H: KEY ON L: KEY OFF
36	I	KR1	Key input H: KEY ON L: KEY OFF
37	I	KR0	Key input H: KEY ON L: KEY OFF
38	I	Vp	Connect to -30 V High-voltage-resistant port pulldown voltage input
39	O	G9	Fluorescent grid output 9G
40	O	G8	Fluorescent grid output 8G
41	O	G7	Fluorescent grid output 7G
42	O	G6	Fluorescent grid output 6G
43	O	G5	Fluorescent grid output 5G
44	O	G3	Fluorescent grid output 3G
45	O	G2	Fluorescent grid output 2G
46	O	G1	Fluorescent grid output 1G

CIRCUIT DESCRIPTION

Pin Description

Pin No.	I/O	Name	Function
47	O	Sa	Fluorescent segment output a
48	O	Sb	Fluorescent segment output b
49	O	Sc	Fluorescent segment output c
50	O	Sd	Fluorescent segment output d
51	O	Se	Fluorescent segment output e
52	O	Sf	Fluorescent segment output f
53	O	Sg	Fluorescent segment output g
54	O	Sh	Fluorescent segment output h
55	O	Si	Fluorescent segment output i
56	O	Sj	Fluorescent segment output j
57	O	Sk	Fluorescent segment output k
58	O	Sl	Fluorescent segment output l
59	O	Sm	Fluorescent segment output m
60	O	Sn	Fluorescent segment output n
61	O	So	Fluorescent segment output o
62	O	Sp	Fluorescent segment output p
63	-	Avcc	Analog-to-digital converter power supply. Connect to backed-up +5V.
64	-	Vcc	Power supply pin. Connect to backed-up +5V.

KX-W8040

CIRCUIT DESCRIPTION

I/O EXPANDER (CXD1067P)

I/O 1

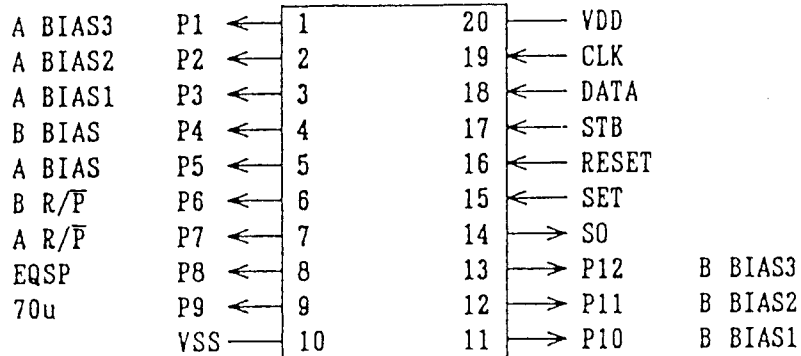

I/O 2

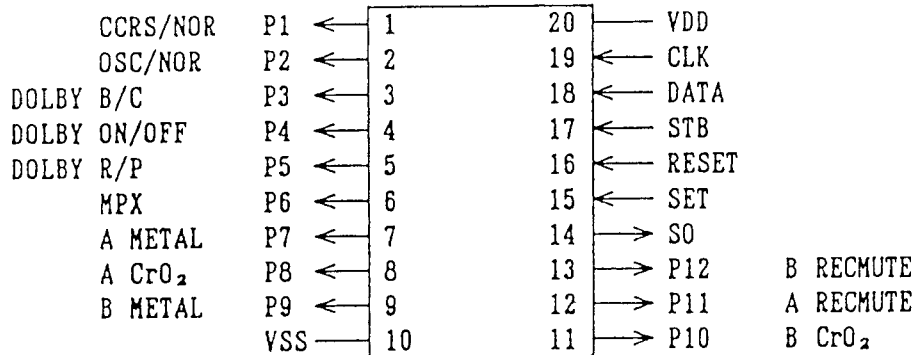

I/O 3

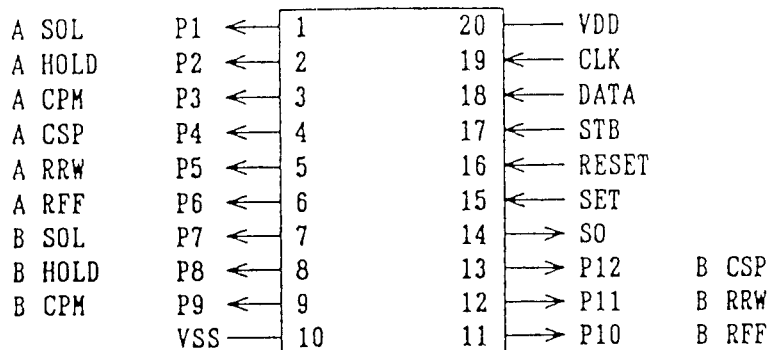

CIRCUIT DESCRIPTION

Pin Description

I/O 1.

Pin No.	I/O	Name	Function
1	O	A BIAS3	For AUTOBIAS for deck A
2	O	A BIAS2	For AUTOBIAS for deck A
3	O	A BIAS1	For AUTOBIAS for deck A
4	O	B BIAS	B bias control H: BIAS ON L: BIAS OFF
5	O	A BIAS	A bias control H: BIAS ON L: BIAS OFF
6	O	B R/P	B REC/PLAY switching H: REC L: PLAY
7	O	A R/P	A REC/PLAY switching H: REC L: PLAY
8	O	EQSP	B record equalization switching H: NORMAL SPEED L: HIGH SPEED
9	O	70 μ	Playback equalization time-constant switching H: 70 μ s L: 120 μ s
10	-	Vss	Connect to ground.
11	O	B BIAS1	For AUTOBIAS for deck B
12	O	B BIAS2	For AUTOBIAS for deck B
13	O	B BIAS3	For AUTOBIAS for deck B
14	O	SO	Data output pin. Connect to the data pin of I/O expander 2.
15	I	SET	Connect to VDD (+5V). H: NORMAL L: All ports are low H
16	I	RESET	Connect to the EXRST pin of the microprocessor. H: NORMAL L: All ports are low L
17	I	STB	Strobe signal input in. Connect to the EXST pin of the microprocessor.
18	I	DATA	Data input pin. Connect to the EXDATA pin of the microprocessor.
19	I	CLK	Clock input pin. Connect to the EXCLK pin of the microprocessor.
20	-		Power supply pin. Connect to +5V.

I/O 2.

Pin No.	I/O	Name	Function
1	O	A SOL	A solenoid control H: ON L: OFF
2	O	A HOLD	A solenoid hold control H: ON L: OFF
3	O	A CPM	A main motor control. Hub motor speed change. H: ON L: OFF
4	O	A CSP	A main motor speed change H: NORMAL SPEED L: HIGH SPEED
5	O	A RRW	A reel motor control H: REWIND, RVS L: Others
6	O	A RFF	A reel motor control H: FF, FWD L: Others
7	O	B SOL	B solenoid control H: ON L: OFF
8	O	B HOLD	B solenoid hold control H: ON L: OFF
9	O	B CPM	B main motor control. Reel motor speed change. H: ON L: OFF
10	-	Vss	Ground pin. Connect to ground.
11	O	B RFF	B reel motor control H: FF, FWD L: Others
12	O	B RRW	B reel motor control H: REWIND, RVS L: Others
13	O	B CSP	B main motor speed change H: NORMAL L: HIGH SPEED
14	O	SO	Data output pin. OPEN
15	I	SET	Connect to VDD (+5V). H: NORMAL L: All ports are low H
16	I	RESET	Connect to the EXRST pin of the microprocessor. H: NORMAL L: All ports are low.
17	I	STB	Strobe signal input pin. Connect to the EXST pin of the microprocessor.
18	I	DATA	Data input pin. Connect to the S0 pin of I/O expander 2.
19	I	CLK	Clock input pin. Connect to the EXCLK pin of the microprocessor
20	-	V	Power supply pin. Connect to +5V.

KX-W8040

CIRCUIT DESCRIPTION

I/O 3.

Pin No.	I/O	Name	Function		
1	O	CCRS/NOR	CCRS/normal switching	H: CCRS	L: NORMAL
2	O	OSC/NOR	AUTOBIAS/normal switching	H: AUTOBIAS	L: NORMAL
3	O	DOLBY B/C	Dolby B/C switching	H: B TYPE	L: C TYPE
4	O	DOLBY ON/OFF	Dolby on/off switching	H: DOLBY OFF	H: DOLBY ON
5	O	DOLBY R/P	Dolby REC/PLAY switching	H: PLAY	L: REC
6	O	MPX	MPX on/off control	H: MPX ON	L: MPX OFF
7	O	A METAL	A recording equalization switching (BIAS)	H: METAL	L: NOT METAL
8	O		A recording equalization switching		
9	O	B METAL	B recording equalization switching		
10	-	Vss	Ground pin. Connect to ground.		
11	O		B recording equalization switching	H: CrO2	L: NOT METAL
12	O	A RECMUTE	A recording mute control	H: REC MUTE OFF	L: REC MUTE ON
13	O	B RECMUTE	B recording mute control	H: REC MUTE OFF	L: REC MUTE ON
14	O	SO	Data output pin. Connect to the data pin of I/O expander 3.		
15	I	SET	Connect to VDD (+5V).	H: NORMAL	L: ALL ports are low
16	I	RESET	Connect to the EXRST pin of the microprocessor.	H: NORMAL	L: ALL ports are low
17	I	STB	Strobe signal input pin. Connect to the EXST pin of the microprocessor.		
18	I	DATA	Data input pin. Connect to the S0 pin of I/O expander 1.		
19	I	CLK	Clock input pin. Connect to the EXCLK pin of the microprocessor.		
20	-		Power supply pin. Connect to +5V.		

CIRCUIT DESCRIPTION

Test Mode

1. Test 1

(a) Setting

Short test pins (TP 3 → 4) with a diode, and plug in the AC cord.

(b) Cancel

To cancel the test mode, press the PAUSE key on deck A or B, or switch the power off. Note that the direction and counter values while in the test mode are stored in memory. If the AC cord is disconnected while in the test mode, the memory is initialized completely.

(c) Operation

Mode	Operation																
All indicators on	All indicators light two seconds after the power is switched on, then the normal display resumes (except for the meter section).																
Mechanical switch display (DIRECTION switch)	<table style="width: 100%; border-collapse: collapse;"> <tr> <td style="width: 20%;"></td> <td style="width: 20%; text-align: center;">0</td> <td style="width: 20%; text-align: center;">+3</td> <td style="width: 20%; text-align: center;">+6</td> </tr> <tr> <td>L INHFA</td> <td style="text-align: center;">CrO2A</td> <td style="text-align: center;">METALA</td> <td style="text-align: center;">INHRA</td> </tr> <tr> <td style="text-align: center;">-15</td> <td style="text-align: center;">-10</td> <td style="text-align: center;">-6</td> <td style="text-align: center;">-3</td> </tr> <tr> <td>R INHFB</td> <td style="text-align: center;">CrO2B</td> <td style="text-align: center;">METALB</td> <td style="text-align: center;">INHRB</td> </tr> </table>		0	+3	+6	L INHFA	CrO2A	METALA	INHRA	-15	-10	-6	-3	R INHFB	CrO2B	METALB	INHRB
	0	+3	+6														
L INHFA	CrO2A	METALA	INHRA														
-15	-10	-6	-3														
R INHFB	CrO2B	METALB	INHRB														
Four-second recording (for decks A and B)	<p>When the REC key is pressed, the counter is reset to 0.000, recording is done for four seconds, then the recorded part is played back from the beginning.</p> <ul style="list-style-type: none"> The key is accepted at any time. 																
Timer play	<table style="width: 100%; border-collapse: collapse;"> <tr> <td style="width: 70%;">Deck A high-speed playback</td> <td style="text-align: right;">4 seconds</td> </tr> <tr> <td>Deck A normal-speed playback</td> <td style="text-align: right;">12 seconds</td> </tr> <tr> <td>Deck B high-speed playback</td> <td style="text-align: right;">4 seconds</td> </tr> <tr> <td>Deck B normal-speed playback</td> <td style="text-align: right;">12 seconds</td> </tr> </table>	Deck A high-speed playback	4 seconds	Deck A normal-speed playback	12 seconds	Deck B high-speed playback	4 seconds	Deck B normal-speed playback	12 seconds								
Deck A high-speed playback	4 seconds																
Deck A normal-speed playback	12 seconds																
Deck B high-speed playback	4 seconds																
Deck B normal-speed playback	12 seconds																
Time recording	<table style="width: 100%; border-collapse: collapse;"> <tr> <td style="width: 50%;">Deck B recording</td> <td style="text-align: right;">15 seconds</td> </tr> <tr> <td colspan="2">Rewind to the beginning.</td> </tr> <tr> <td>Deck B playback</td> <td style="text-align: right;">13 seconds</td> </tr> <tr> <td>Deck B stop</td> <td></td> </tr> </table> <p>Note: Time recording is not done if there is no cassette in deck B.</p>	Deck B recording	15 seconds	Rewind to the beginning.		Deck B playback	13 seconds	Deck B stop									
Deck B recording	15 seconds																
Rewind to the beginning.																	
Deck B playback	13 seconds																
Deck B stop																	
Speed change	<p>FWD PLAY key Normal playback (FWD) FF key High-speed playback (FWD) RVS PLAY key Normal playback (RVS) RWD key Rewind</p> <p>Note: If the FWD PLAY and FF keys are pressed alternately, the head does not retract.</p>																
High-speed recording	<p>When the H. CCRS key is pressed, high-speed recording is done on deck B. Note: High-speed recording is not done if there is no cassette in deck B.</p>																
Dubbing H ↔ L	<p>If the H. DUB and N. DUB keys are pressed alternately, the dubbing speed can be changed without retracting the head. Note: The speed cannot be changed if there is no cassette in deck B.</p>																
Input level ATT	<p>When the N. CCRS key is pressed, recording pauses, and the level can be input. If the input is excessive (+5 dB or higher), the PWM is changed and the level is set. When the REC key is pressed, recording can be done at the specified level. Note that the level is canceled when another operation is performed.</p>																
Keys to be inhibited	<p>The DPSS mode is not entered. Note that the display is slightly different from the normal one.</p>																

KX-W8040

ADJUSTMENT

No.	ITEM	INPUT SETTINGS	OUTPUT SETTINGS	CASSETTE TAPE DECK SETTINGS	ALIGNMENT POINTS	ALIGN FOR	FIG.
CASSETTE DECK SECTION		TAPE: NORMAL, DOLBY: OFF, INPUT: LINE				0dBs = 0.775V	
I REC/PLAY HEAD							
[1]	DEMAGNETIZATION	-	-	POWER: OFF Remove the cassette door.	REC/PLAY head	Demagnetize the REC/PLAY head with a head demagnetizer.	
[2]	CLEANING	-	-	PLAY	REC/PLAY head erase head, capstan, pinch roller.	Clean the REC/PLAY head erase head, capstan and pinch roller using a cotton swab slightly damped with alcohol.	
[3]	AZIMUTH	MTT-114, TCC-153 SCC-1727 10kHz, -10dB	(B)	PLAY	Azimuth adjustment screw	Maximum output.	(a)
II PC BOARD (X28-231)							
(1)	TAPE SPEED (HI SPEED)	MTT-111, TCC-110 SCC-1727 3kHz -4dB	(B)	Test mode test FF key HI speed F. PLAY key Normal speed	DECK A: VR1 (VR103) on each own mechanism board	Adjust the tape speed so that a 6kHz signal is produced at the center of the tape.	
(2)	TAPE SPEED (NORMAL)	MTT-111, TCC-110 SCC-1727 3kHz -4dB	(B)		DECK A: DECK B: VR2 (VR223) on each own mechanism board	Adjust the tape speed so that a 3kHz signal is produced at the center of the tape.	
(3)	QUICK REVERSE SENSITIVITY	Use the leader section of the test tape.	Connect a DC voltmeter to TP5 and GND (A) TP6 and GND (B)	PLAY	DECK A: VR9 DECK B: VR10	Adjust the semi-fixed resistances so that 0.75V ($\pm 0.15V$) voltage is obtained.	(b)
III PC BOARD (X28-231)							
<1>	PLAYBACK LEVEL	MTT-150 400Hz(200nWb)	(B)	PLAY	DECK A: VR1(L) VR2(R) DECK B: VR3(L) VR4(R)	Output level: -3.0dBs	
		MTT-256, SCC-1727 315Hz(160nWb)				Output level: -6.0dBs	
		MTT-256U, TCC-160 SCC-1176 315Hz(220nWb)				Output level: -2.0dBs	
<2>	BIAS CURRENT	(A) 1kHz, -30dBs 10kHz, -30dBs	(B)	Adjust REC level volume so that the REC monitor output becomes -29dBs at 1kHz, then record and reproduce signal of 1kHz and 10kHz in alternation.	DECK A: VR5(L) VR6(R) DECK B: VR7(L) VR8(R)	Record 1kHz and 10kHz in alternation and adjust the variable resistors which control the bias current so that the same playback level is obtained.	
<3>	BIAS OSCILLATING FREQUENCY	Load the non recorded tapes on Deck A and B.	Connect the frequency counter between TP1 and GND on Deck A, between TP2 and GND on Deck B.	REC	DECK A: L3 DECK B: L4	Adjust so that the frequency counter shows 105kHz.	(c)
<4>	BIAS LEAK	Load a non recorded tape on Deck A	(B)	Load a metal tape, and dub in a high speed mode.	DECK A: L5(L) L6(R) DECK B: L7(L) L8(R)	Minimum (Point)	

REGLAGE

N°	ITEM	REGLAGE DE L'ENTREE	REGLAGE DE LA SORTIE	REGLAGE DU MAGNETO-PHONE A CASSETTE	POINTS DE L'ALIGNEMENT	ALIGNER POUR	FIG.
SECTION DU MAGNETOPHONE		TAPE: NORMAL, DOLBY: OFF, ENTREE: LINE				QdBs = 0,775V	
I TETE D'ENREGISTREMENT/LECTURE							
[1]	DEMAGNETISATION	-	-	POWER: OFF Eloigner la porte.	Tête D'ENREGISTREMENT/ LECTURE	Demagnétiser la tête D'ENREGISTREMENT/LECTURE avec un démagnétiseur de tête.	
[2]	NETTOYAGE	-	-	PLAY	Tête D'ENREGISTREMENT/ LECTURE tête d'effacement, cabestan, galetpresseur.	Nettoyer la tête D'ENREGISTREMENT/LECTURE la tête d'effacement, le cabestan et le galetpresseur avec un coton-tige légèrement imbibé d'alcool.	
[3]	AZIMUT	MTT-114, TCC-153 SCC-1727 10kHz, -10dB	(B)	PLAY	Vis d'azimut	Sortie maximer.	(a)
II PLAQUE IMPRIMEE (X28-231)							
(1)	VITESSE DE DEFILEMENT (HI SPEED)	MTT-111, TCC-110 SCC-1727 3kHz -4dB	(B)	Test mode test F.F :HI speed F.PLAY:Normal speed	DECK A: DECK B: VR1 (VR103) sur chaque Plaquette de mécanismes	Régler la vitesse de bande de façon qu'un signal de 6kHz soit produit au centre de la bande.	
(2)	VITESSE DE DEFILEMENT (NORMAL)	MTT-111, TCC-110 SCC-1727 3kHz -4dB	(B)		DECK A: DECK B: VR2 (VR223) sur chaque Plaquette de mécanisme	Régler la vitesse de bande de façon qu'un signal de 3kHz soit produit au centre de la bande.	
(3)	SENSIBILITE D'INVERSION RAPIDE	Utiliser la section-guide de la bande test	Raccorder un voltmètre CC à TP5 et GND (A) à TP6 et GND (B)	PLAY	DECK A: VR9 DECK B: VR10	Ajuster la résistance semi-fixe pour que la tension 0,75V(±0,15V) soit obtenue.	(b)
III PLAQUE IMPRIMEE (X28-231)							
< 1 >	NIVEAU DE LECTURE	MTT-150 400Hz(200nWb)	(B)	PLAY	DECK A: VR1(G) VR2(D) DECK B: VR3(G) VR4(D)	Niveau de sortie: -3.0dBs	
		MTT-256, SCC-1727 315Hz(160nWb)				Niveau de sortie: -6.0dBs	
		MTT-256U, TCC-160 SCC-1176 315Hz(220nWb)				Niveau de sortie: -2.0dBs	
< 2 >	COURANT DE POLARISATION	(A) 1kHz, -30dBs 10kHz, -30dBs	(B)	Régler REC de volume de niveau façon que la sortie de moniteur REC soit de -29dBs à 1kHz, puis en registrer et reproduire des signaux de 1kHz et 10kHz en alternance.	DECK A: VR5(G) VR6(D) DECK B: VR7(G) VR8(D)	Enregistrer un signal de 1kHz et 10kHz en alternance et ajuster les résistances variables qui commandent le courant de polarité de façon à obtenir le même niveau de lecture.	
< 3 >	FREQUENCE D'OSCILLATION DE POLARISATION	Mettre en place des cassettes non enregistrées dans les platines A et B.	Raccorder le compteur de fréquence enter TP1 et GND de la platine A, enter TP2 et GND de la platine B.	Enregistrement	DECK A: L 3 DECK B: L 4 (X28-1380-01)	Régler de manière à ce que le compteur de fréquence indique 115kHz.	(c)
< 4 >	FUITE DE POLARISATION	Mettre en place une cassette non enregistrée dans la platine A	(B)	Mettre en place une bande metal et copier en mode de vitesse élevée.	DECK A: L5(G) L6(D) DECK B: L7(G) L8(D)	Minimum (point)	

KX-W8040

ABGLEICH

NR.	GEGENSTAND	EINGANGS-EINSTELLUNG	AUSGANGS-EINSTELLUNG	KASSETTengerät EINSTELLUNG	ABGLEICH PUNKTE	ABGLEICHEN FÜR	ABB.
CASSETTEN-DECK-ABTEILUNG		TAPE: NORMAL, DOLBY: OFF, EINGANG: LINE				0dBs=0,775V	
I AUFNAHME/WIEDERGABE KOPF							
[1]	ENTMAGNETISIERUNG	-	-	POWER: OFF Den Kassetteneinheitsdeckel oben herausziehen.	AUFNAHME/WIEDERGABE-Kopf	Entmagnetisierung von dem AUFNAHME/WIEDERGABE-Kopf mit einem Tonkopf Entmagnetisierungs-drossel.	
[2]	REINIGUNG	-	-	PLAY	AUFNAHME/WIEDERGABE-Kopf Loschkopf, Tonwelle, Andruckrolle.	AUFNAHME/WIEDERGABE-Kopf, Loschkopf, Tonwelle und Andruckrolle mit einem leicht mit Alkohol befeuch- teten Wattebausch reinigen.	
[3]	AZIMUT EINSTELLUNG	MTT-114, TCC-153 SCC-1727 10kHz, -10dB	(B)	PLAY	Azimut- Einstellschraube	Maximal Ausgang.	(a)
II GEDRUCKTE SCHALTPLATTE (X28-231)							
(1)	BANDGESCHWINDIGKEIT (HI SPEED)	MTT-111, TCC-110 SCC-1727 3kHz -4dB	(B)	Einen Schalthdraht zwischen GND und TP3 anschließen. PLAY	DECK A: DECK B: VR1 (VR103) an der jeweils eigenen Mechanismus-Platine	Die Bandgeschwindigkeit so justieren, daß ein 6kHz Signal auf der Mitte des Bands erzeugt wird.	
(2)	BANDGESCHWINDIGKEIT (NORMAL)	MTT-111, TCC-110 SCC-1727 3kHz -4dB	(B)	PLAY	DECK A: DECK B: VR2 (VR223) an der jeweils eigenen Mechanismus-Platine	Die Bandgeschwindigkeit so justieren, daß ein 3kHz Signal auf der Mitte des Bands erzeugt wird.	
(3)	SCHNELLRÜCKLAUF-EMPFFINDLICHKEIT	Den Vorspann des Testbandes versenden.	Eine Gleichspannungsmesser an TP5 und GND (A), TP6 und GND (B) anschließen.	PLAY	DECK A: VR9 DECK B: VR10	Den halbfesten Widerstand so einstellen, daß die Spannung 0,75V ($\pm 0,15V$) beträgt.	(b)
III GEDRUCKTE SCHALTPLATTE (X28-231)							
<1>	WIEDERGABE-PEGEL	MTT-150 400Hz(200nVb)	(B)	PLAY	DECK A: VR1(L) A VR2(R) DECK B: VR3(L) VR4(R)	Ausgangspegel: -3.0dBs	
		MTT-256, SCC-1727 315Hz (160nVb)				Ausgangspegel: -6.0dBs	
		MTT-256U, TCC-160 SCC-1176 315Hz(220nVb)				Ausgangspegel: -2.0dBs	
<2>	LEERLAUFSTROM	(A) 1kHz, -30dBs 10kHz, -30dBs	(B)	REC so Pegel Lautstärke justieren, daß der REC Monitorausgang -29dBs bei 1kHz wird, und danach abwechselnd Signal von 1kHz und 10kHz aufnehmen und wiedergeben.	DECK A: VR(L) 5(L) VR(R) 6(R) DECK B: VR(L) 7(L) VR(R) 8(R)	Signale von 1kHz und 10kHz abwechselnd aufnehmen und die Regelwiderstände, die den Vormagnetisierungsstrom regeln, so justieren, daß der gleiche Wiedergabepegel erzielt wird.	
<3>	VORMAGNETISIERUNGS OSZILLATIONS-FREQUENZ	Unbespielte Kassetten in Deck A und B einsetzen.	Den Frequenzzähler zwischen TP1 und GND von Deck A und zwischen TP2 und GND von Deck B anschließen.	REC	DECK A: L 3 DECK B: L 4	So einstellen, daß 105kHz auf dem Frequenzzähler angezeigt wird.	(c)
<4>	VORMAGNETISIERUNGSSTREUUNG	Eine unbespielte kassette in Deck A einsetzen.	(B)	Eine Metallbandkassette einsetzen und mit hoher Geschwindigkeit überspielen.	DECK A: L5(L) L6(R) DECK B: L7(L) L8(R)	Minimum (Punkt)	

ADJUSTMENT / REGLAGE / ABGLEICH

WIRING DIAGRAM

SYSTEM CONNECTIONS

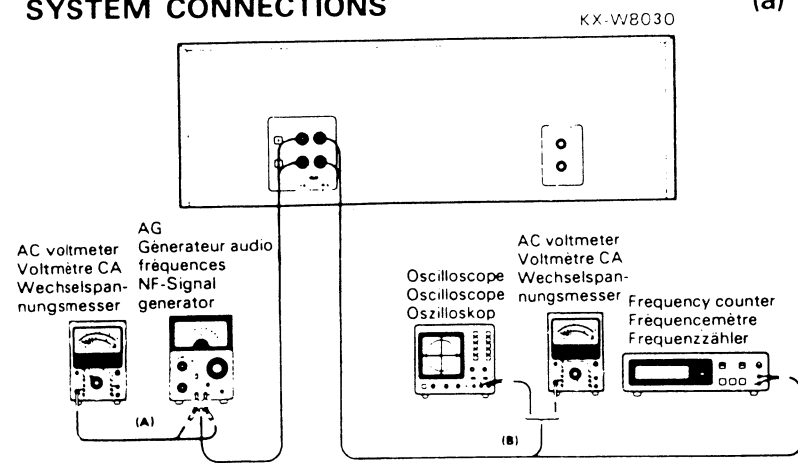

(a) AZIMUTH ADJUSTMENT SCREW

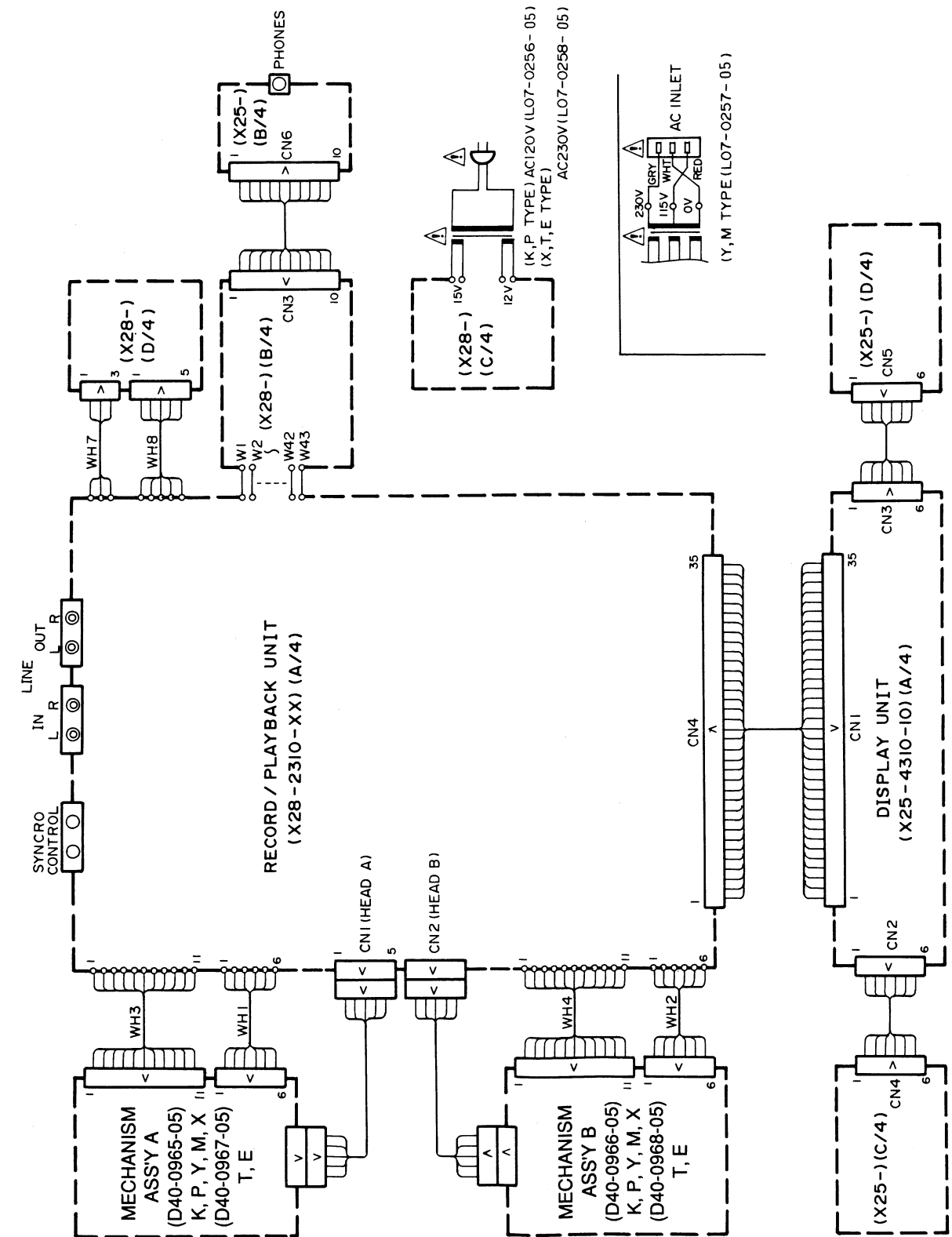
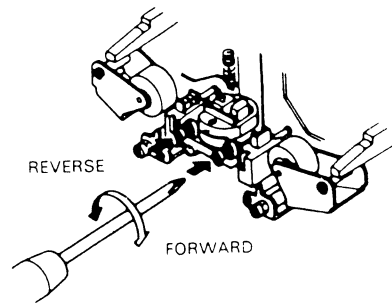

PC BOARD (Component side view)

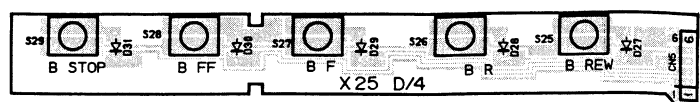
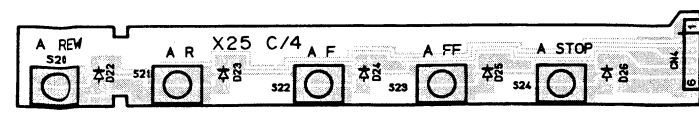
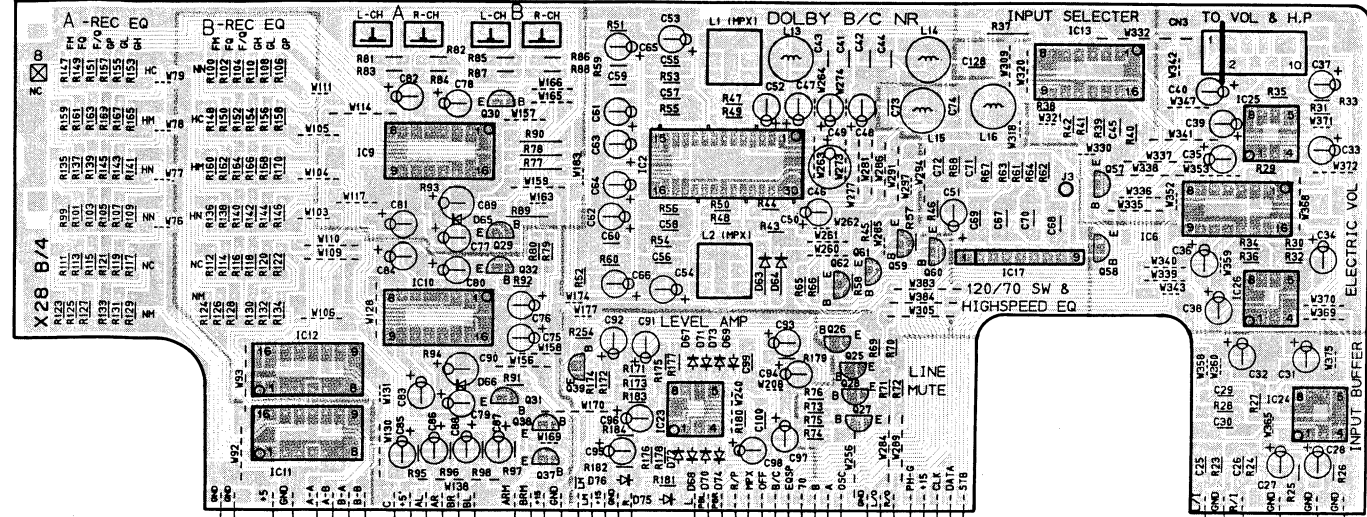
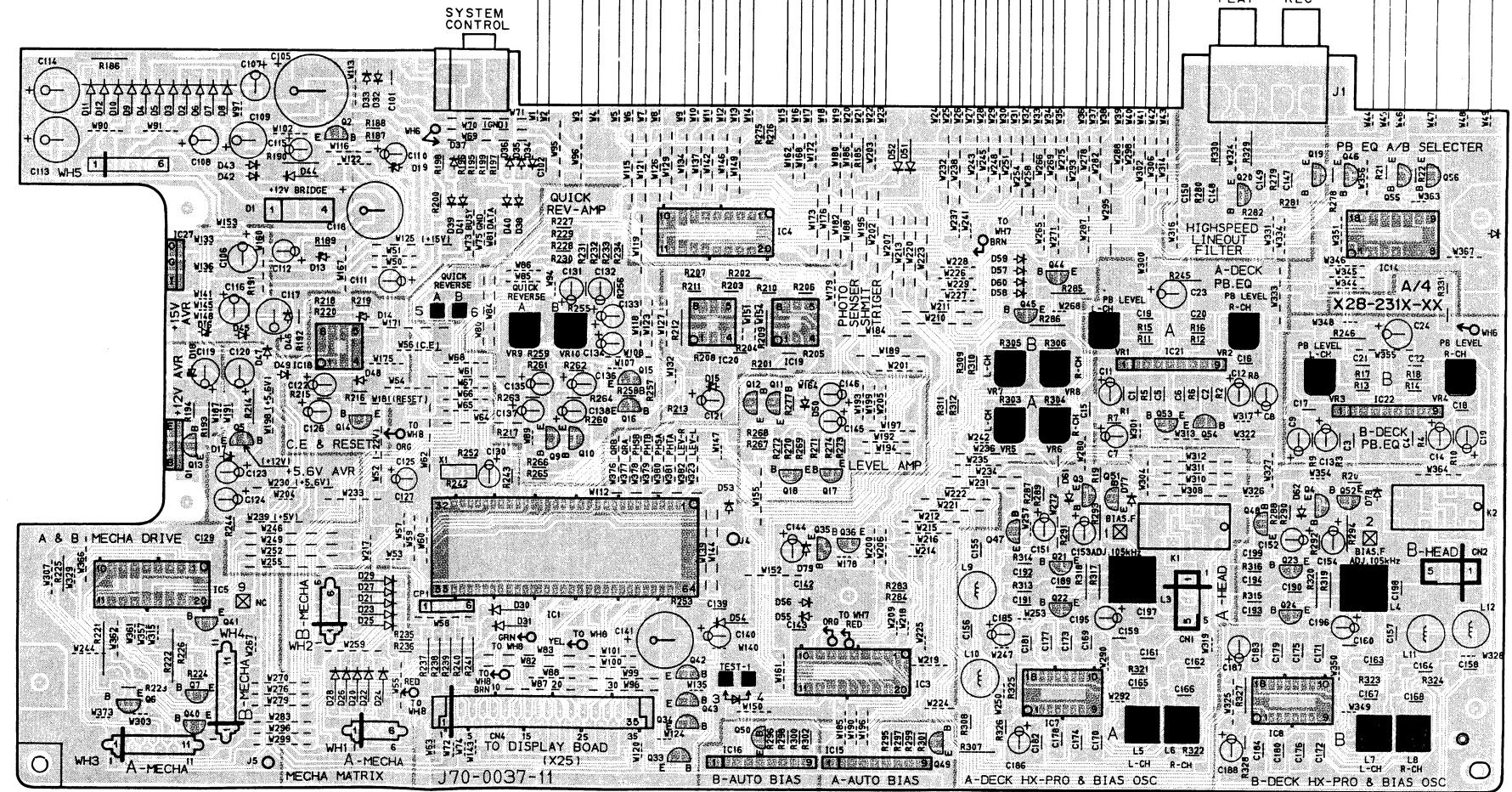
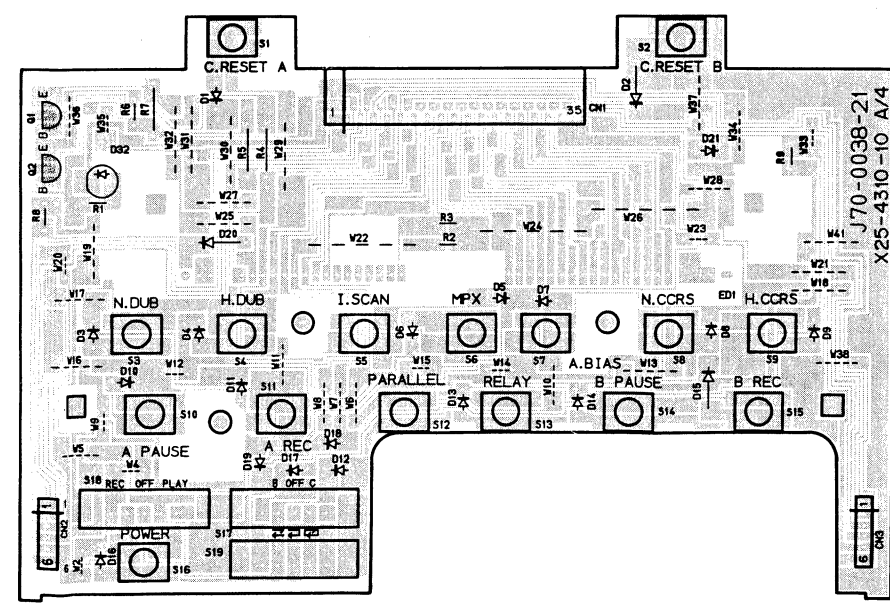
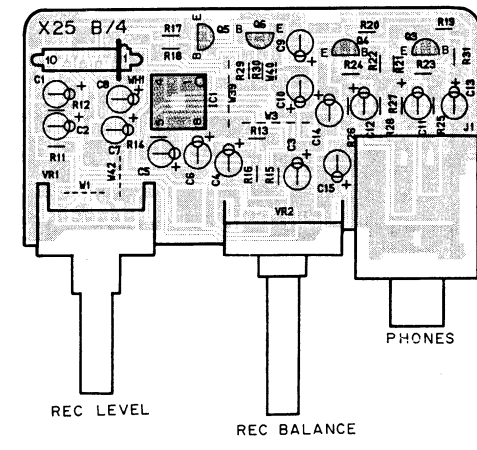
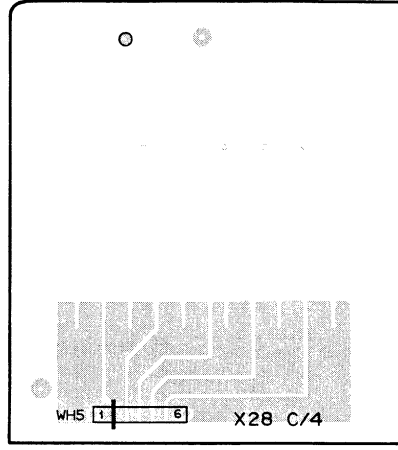
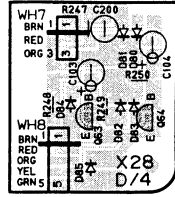

Refer to the schematic diagram for the values of resistors and capacitors.

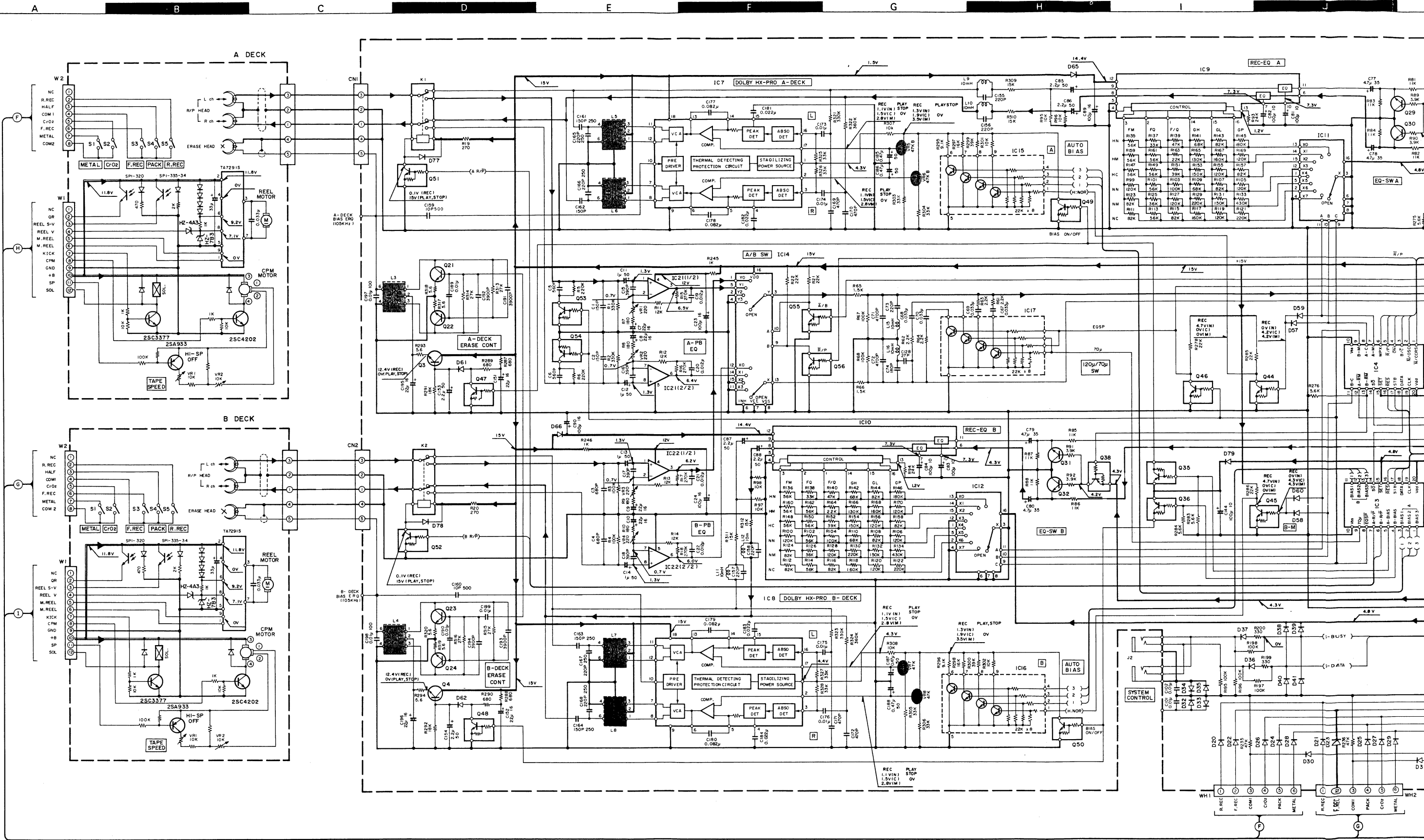

- 2SA999
2SC1845
2SC3246
2SC3940A

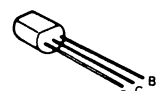

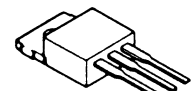
- 2SD1266

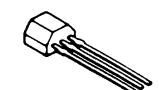

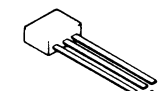
- DTA124ES
DTC124ES
UN4112
2SA933S
2SC1740S

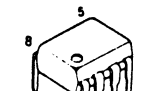

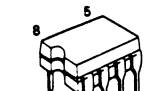
- UN4212
2SA1309A
2SC3311A

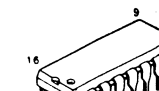

- NJM4558D

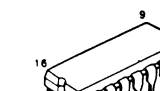

- NJM4565D-D

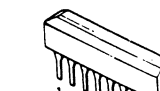

- CXA1198AP
XRU4051B
XRU4052B



- TC4051BP
TC4052BP
TC9213P

- TA8215S
TD62554S

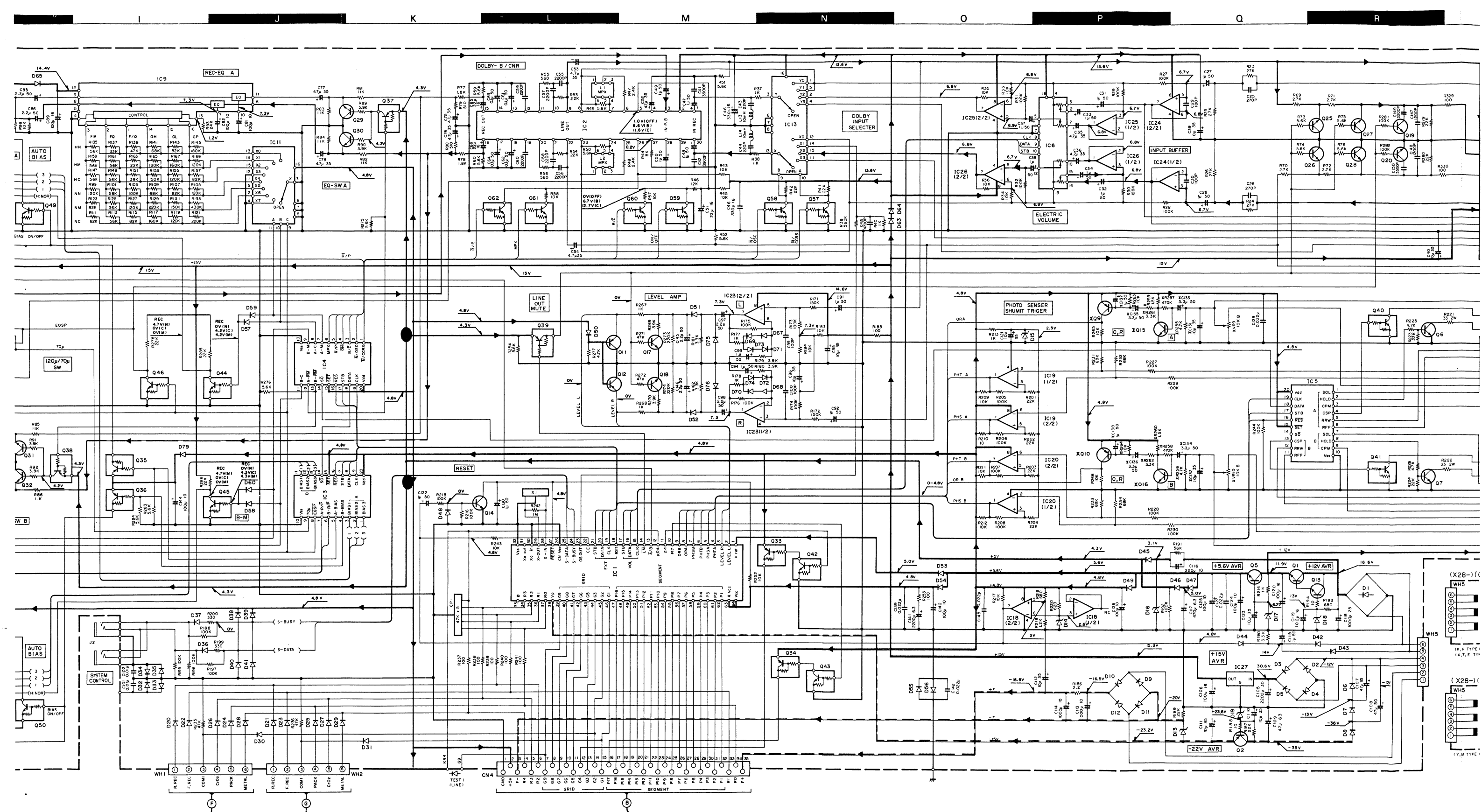

- CXD1067P

- BA10393
RC45651



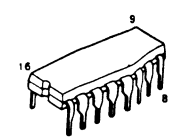

TC4051BP
TC4052BP
TC9213P



TA8215S
TD62554S

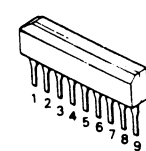

CXD1067P

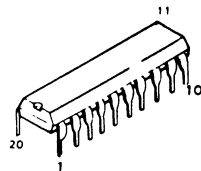

BA10393
RC4565D-D

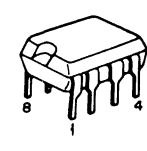

UPC7815HF

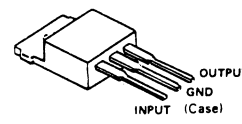

HA12170NT

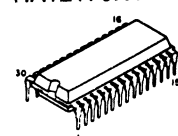

UPC1297CA

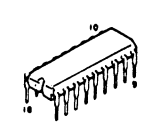

M50945-129SP

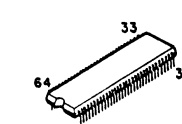

DC voltages are as measured with a high impedance voltmeter with a cassette loaded at playback mode. Values may vary slightly due to variations between individual instruments or/and units. Bias circuit DC voltages are as measured while in the record mode.

Les tensions c.c. doivent être mesurées avec un voltmètre à haute impédance, une cassette étant insérée en mode de lecture. Les valeurs peuvent différer légèrement du fait des variations inhérentes aux appareils et aux instruments de mesure individuels.

Les tensions c.c. du circuit de polarité doivent être mesurées, l'appareil étant en mode d'enregistrement.

Die angegebenen Gleichspannungswerte wurden mit einer spannungsmessenden Kassette in der Wiedergabe mit einem Spannungsmesser gemessen. Dabei schwanken die Werte aufgrund von Unterschieden zwischen den Instrumenten oder Geräten u. U. geringfügig. Die Gleichspannungswerte der Vormagnetisierung wurden in der Aufnahmeart gemessen.

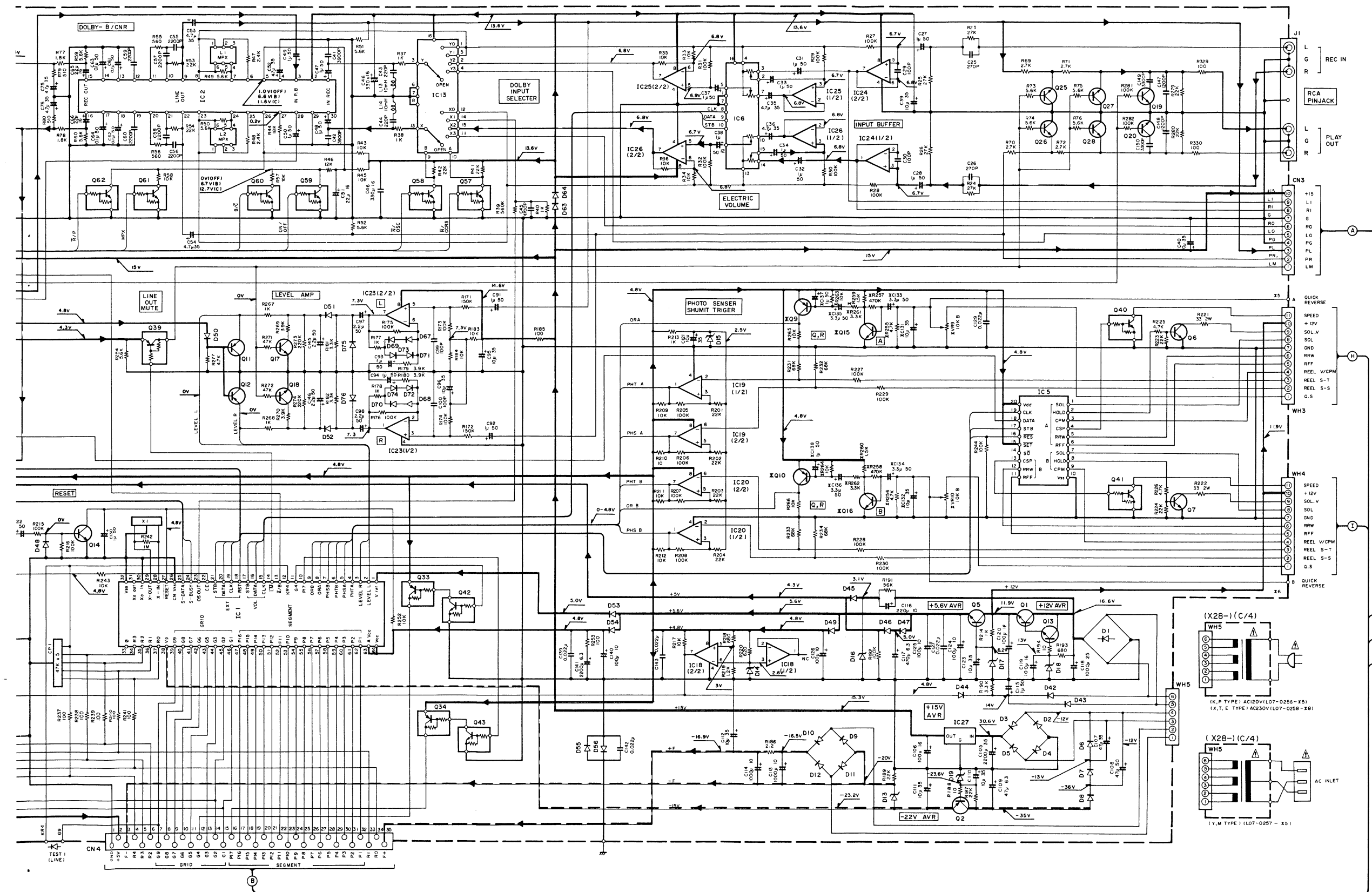

- IC1 : M50945-129SP
- IC2 : HA12170NT
- IC3, 4, 5 : CXD1067P
- IC6 : TC9213P
- IC7, 8 : μ PC1297CA
- IC9, 10 : CXA1198AP
- IC11, 12 : XR4051B or TC4051BP
- IC13, 14 : XR4052B or TC4052BP
- IC15, 16, 17 : TD62554S
- IC18, 19, 20 : BA10393
- IC21, 22 : TAB125S
- IC23 : NUM4558D
- IC24, 25, 26 : RC4565D-D or NJM4565D-D or BA15218DX
- IC27 : μ PC7815HF
- Q1 : 2SD1266 (Q,P)
- Q2 : 2SA999 (E,F)
- Q3, 4, 5 : 2SC3940A
- Q6, 7 : 2SC3246
- Q9~12 : 2SA1309A (Q,R) or 2SA933S (Q,R)
- Q13~32 : 2SC3311A (Q,R) or 2SC1740S (Q,R)
- Q33~39 : UN4112 or DTA124ES
- Q40~62 : UN4212 or DTC124ES
- D1 : KBP02ML-6127
- D2~5, 9~12 : 1SR139-100 or S5688B
- D13, 14, 15 : RD2, 7ES (B2) or HZS2, 7N (B2)
- D16 : RD4, 7ES (B) or HZS4, 7N (B)
- D17 : RD6, 2ES (B2) or HZS6, 2N (B2)
- D18 : RD13ES (B2) or HZS13N (B2)
- D19 : RD24ES (B) or HZS24N (B)
- D30, 31 : RB721Q
- D6~8, 20~29, 32~79 : ISS133 or HSS104

— SIGNAL LINE
 - - - REC LINE
 --- GND LINE
 + + + +B LINE

DESTINATION	K,P,Y,M,X 0-12	T, E 0-13
QUIC REVERSE		
R331	220	330
VR9, VR10		
Q9, Q10		
Q15, Q16	YES	NO
C131 ~ C138		
R255 ~ R264		
PIN5, 6		

KX-W8040

PC7815HF HA12170NT UPC1297CA M50945-129SP

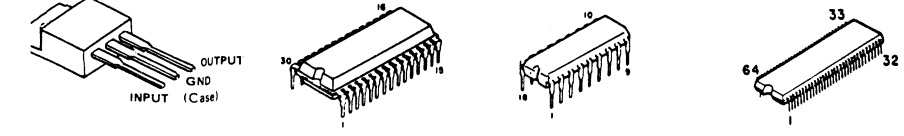

DC voltages are as measured with a high impedance voltmeter with a cassette loaded at playback mode. Values may vary slightly due to variations between individual instruments or/and units. Bias circuit DC voltages are as measured while in the record mode.

Les tensions c.c. doivent être mesurées avec un voltmètre à haute impédance, une cassette étant insérée en mode de lecture. Les valeurs peuvent différer légèrement du fait des variations inhérentes aux appareils et aux instruments de mesure individuels.

Les tensions c.c. du circuit de polarité doivent être mesurées, l'appareil étant en mode d'enregistrement.

Die angegebenen Gleichspannungswerte wurden bei eingesetzter Cassette in der Wiedergabe mit einem hochohmigen Spannungsmesser gemessen. Dabei schwanken die Meßwerte aufgrund von Unterschieden zwischen einzelnen Instrumenten oder Geräten u. U. geringfügig. Die angegebenen Gleichspannungswerte der Vormagnetisierungsschaltung wurden in der Aufnahme-Betriebsart gemessen.

CAUTION: For continued safety, replace safety critical components only with manufacturer's recommended parts (refer to parts list). Δ Indicates safety critical components. To reduce the risk of electric shock, leakage-current or resistance measurements shall be carried out (exposed parts are acceptably insulated from the supply circuit) before the appliance is returned to the customer.



X25-4310-10 (DISPLAY/KEY MATRIX) (A/4)

(X25-)(D/4)

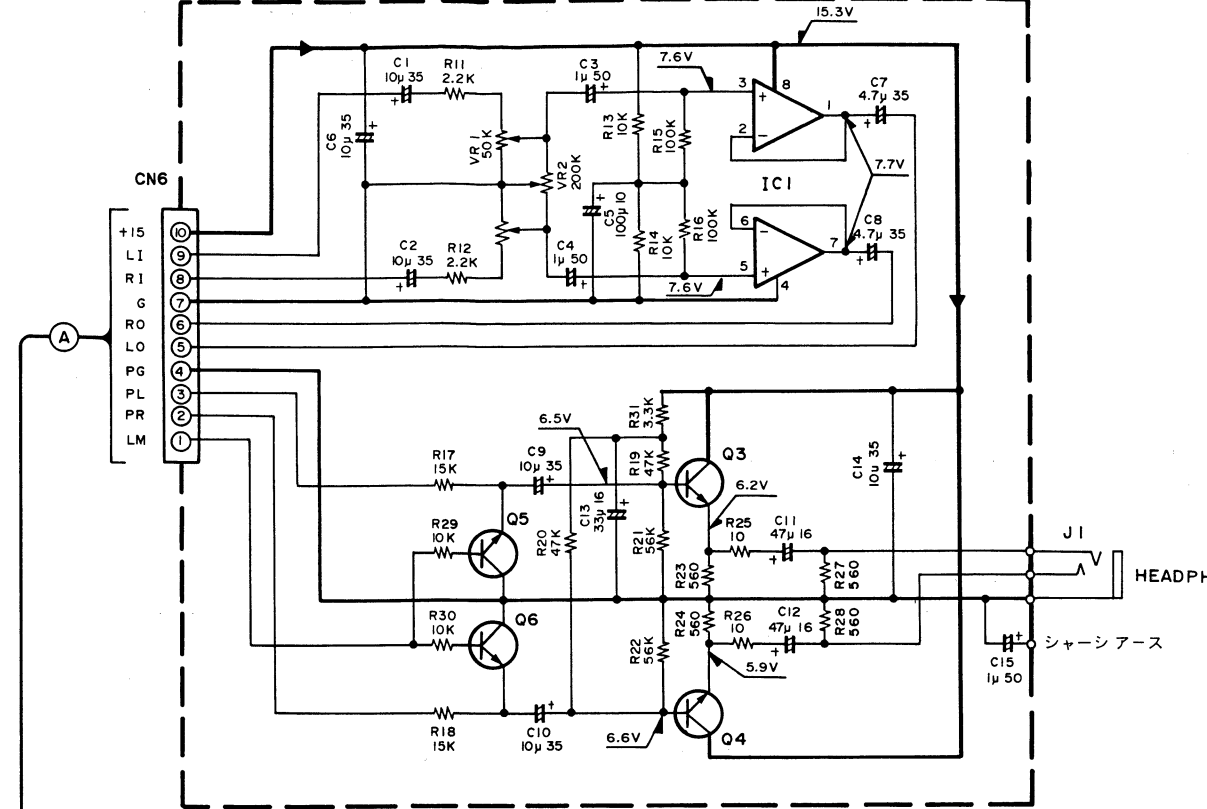
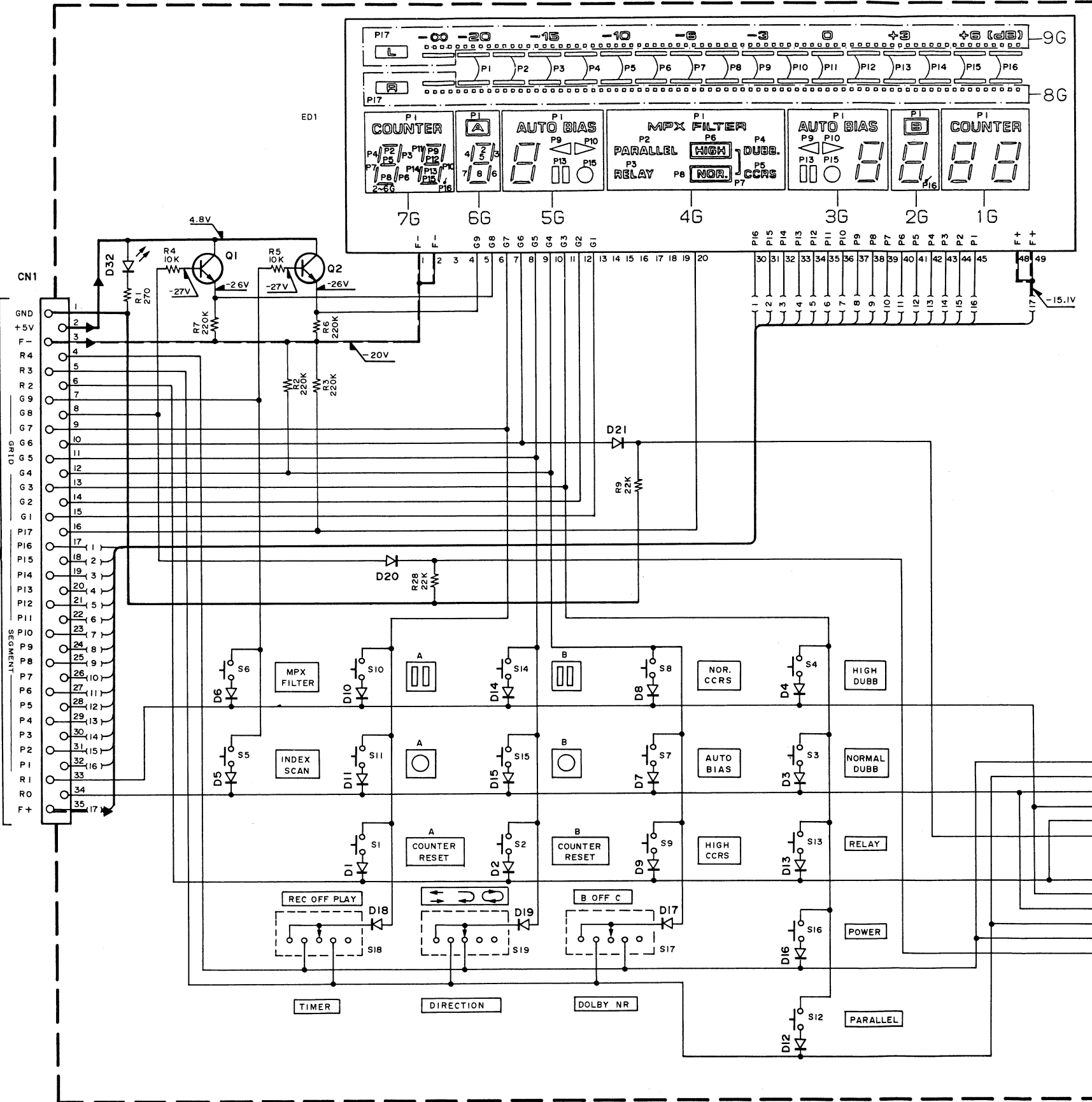

- D1~D31 ISS133 or HSS104
- D32 B30-1291-05
- Q1, Q2 2SC3311 (A) (Q,R) or
- Q5, Q6 2SC1740S (Q,R)
- Q3, Q4 2SC1845 (F,E)
- IC1 RC4565D-D or
- NJM4565D-D or
- ED1 BG-952GK

(X25-)(B/4)

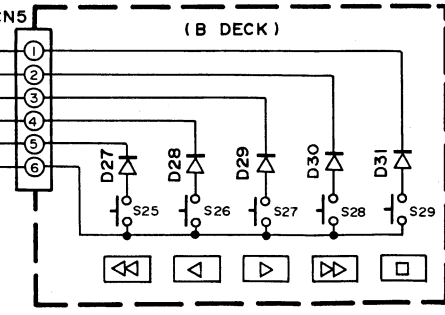

(X25-)(C/4)

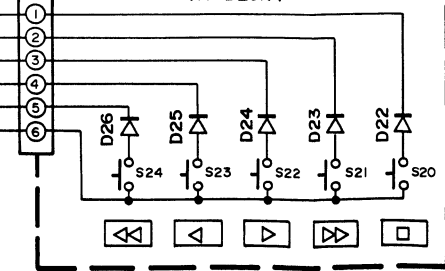

DC voltages are as measured with a high impedance voltmeter with a cassette loaded at playback mode. Values may vary slightly due to variations between individual instrument or/and units. Bias circuit DC voltages are as measured while in the record mode.

Les tensions c.c. doivent être mesurées avec un voltmètre haute impédance, une cassette étant insérée en mode de lecture. Les valeurs peuvent différer légèrement du fait des variations inhérentes aux appareils et aux instruments de mesure individuels.

Les tensions c.c. du circuit de polarité doivent être mesurées l'appareil étant en mode d'enregistrement.

Die angegebenen Gleichspannungswerte wurden bei eingesetzter Cassette in der Wiedergabe mit einem hochohmigen Spannungsmesser gemessen. Dabei schwanken die Messwerte aufgrund von Unterschieden zwischen einzelnen Instrumenten oder Geräten u. U. geringfügig. Die angegebenen Gleichspannungswerte der Vormagnetisierungsschaltung wurden in der Aufnahme-Betriebsart gemessen.

CAUTION: For continued safety, replace safety critical components only with manufacturer's recommended parts (refer to parts list). **⚠** Indicates safety critical components. To reduce risk of electric shock, leakage-current or resistance measurement shall be carried out (exposed parts are acceptably insulated the supply circuit) before the appliance is returned to the user.

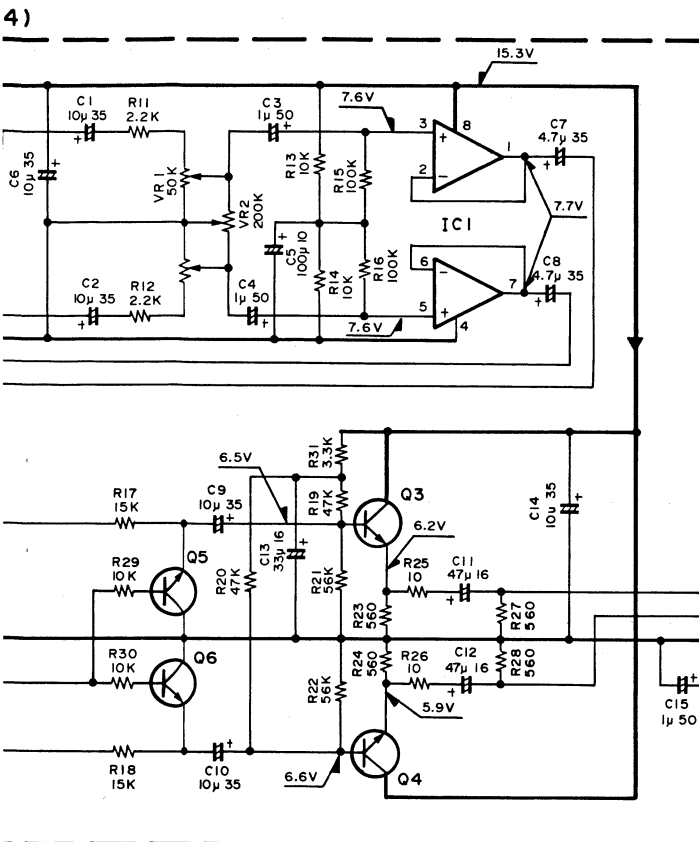

- D1~D31 ISSI 33 or HSS104
- D32 B30-1291-05
- Q1, Q2 2SC3311 (A) (Q,R) or
- Q5, Q6 2SC1740S (Q,R)
- Q3, Q4 2SC1845 (F,E)
- IC1 RC4565D-D or
- NJM4565D-D or
- ED1 BG-952GK

DC voltages are as measured with a high impedance voltmeter with a cassette loaded at playback mode. Values may vary slightly due to variations between individual instruments or/and units. Bias circuit DC voltages are as measured while in the record mode.

Les tensions c.c. doivent être mesurées avec un voltmètre à haute impédance, une cassette étant insérée en mode de lecture. Les valeurs peuvent différer légèrement du fait des variations inhérentes aux appareils et aux instruments de mesure individuels.

Les tensions c.c. du circuit de polarité doivent être mesurées, l'appareil étant en mode d'enregistrement.

Die angegebenen Gleichspannungswerte wurden bei eingesetzter Cassette in der Wiedergabe mit einem hochohmigen Spannungsmesser gemessen. Dabei schwanken die Meßwerte aufgrund von Unterschieden zwischen einzelnen Instrumenten oder Geräten u. U. geringfügig. Die angegebenen Gleichspannungswerte der Vormagnetisierungsschaltung wurden in der Aufnahme-Betriebsart gemessen.

CAUTION: For continued safety, replace safety critical components only with manufacturer's recommended parts (refer to parts list). **⚠** Indicates safety critical components. To reduce the risk of electric shock, leakage-current or resistance measurements shall be carried out (exposed parts are acceptably insulated from the supply circuit) before the appliance is returned to the customer.

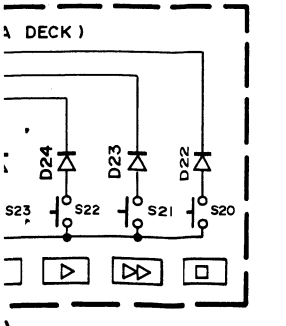
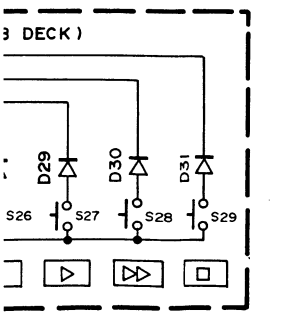

EXPLODED VIEW (MECHANISM)

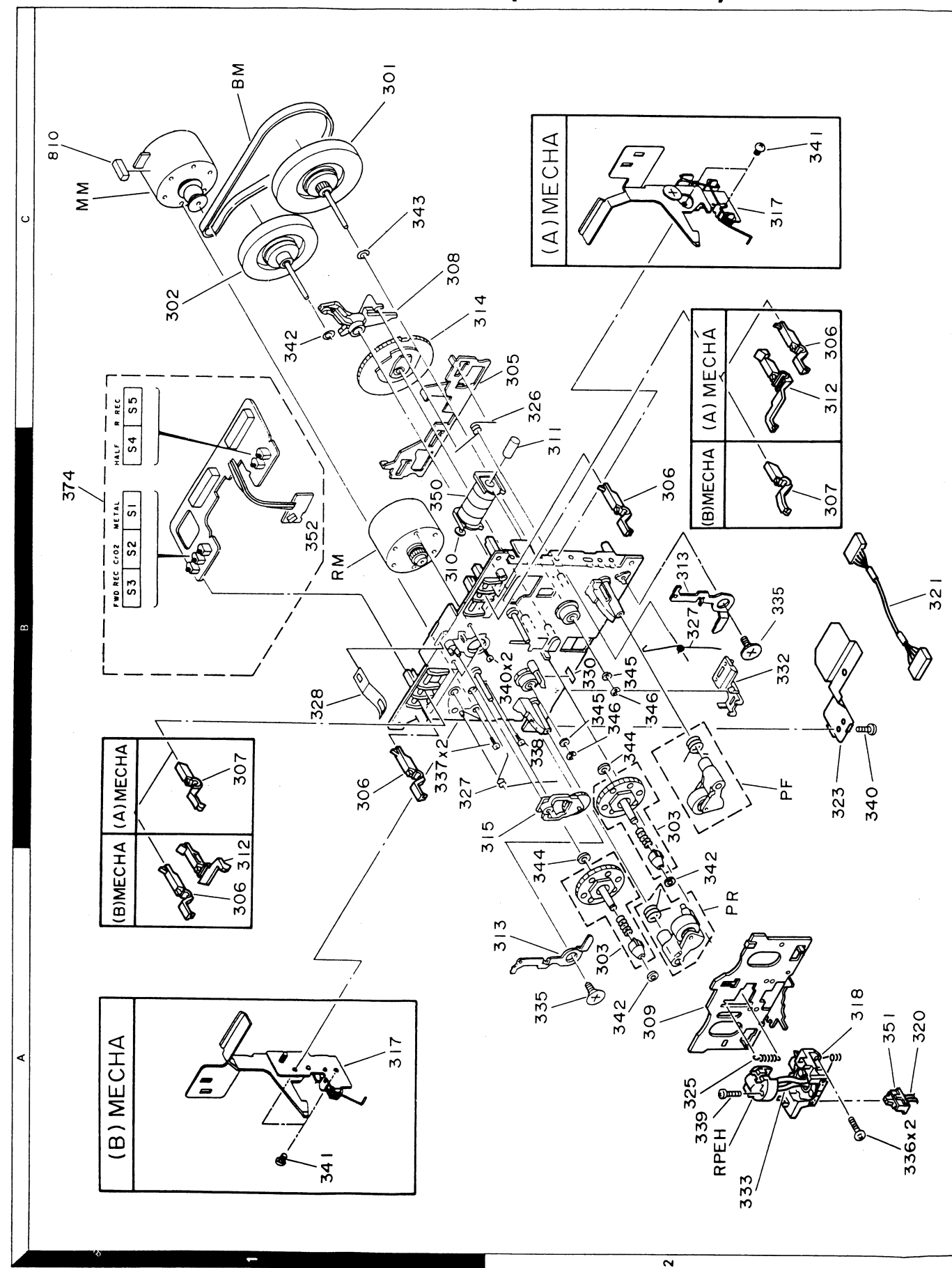

Parts with the exploded numbers larger than 700 are not supplied.

KX-W8040
KENWOOD

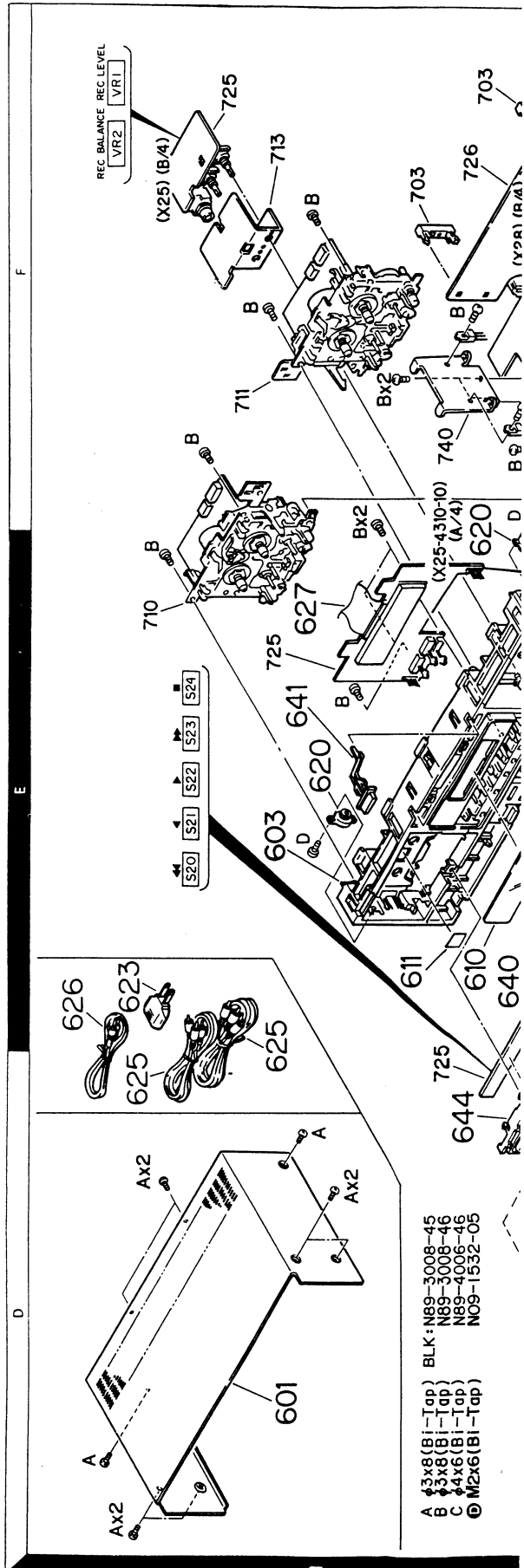

- A 3x8 (BI-Top) BLK: N89-3008-45
- B 3x8 (BI-Top) N89-3008-46
- C 4x6 (BI-Top) N89-4006-46
- Ⓞ M2x6 (BI-Top) N09-1532-05

* New Parts

Parts without Parts No. are not supplied.

Les articles non mentionnés dans le Parts No. ne sont pas fournis.

Teile ohne Parts No. werden nicht geliefert.

No.1

Ref. No. 参照番号	Address 位置	New Parts 新	Parts No. 部品番号	Description 部品名/規格	Desti- nation 仕向	Re- marks 備考
KX-W8040						
601	1D		A01-1935-01	METALLIC CABINET		
602	1D		A21-1790-03	DRESSING PANEL		
603	1E		A22-1479-01	SUB PANEL		
604	1D, 2D	*	A53-1335-04	CASSETTE LID		
605	2D		A53-1283-03	CASSETTE HOLDER ASSY		A
606	2D		A53-1285-03	CASSETTE HOLDER ASSY		B
607	2D	*	A60-0196-02	PANEL		
610	1E		B03-2704-03	DRESSING PLATE		
611	1E		B07-1720-04	ESCUTCHEON		
612	2D		B07-1990-03	ESCUTCHEON CASSETTE HOLDER	KPYMX	A
612	2D		B07-1995-03	ESCUTCHEON CASSETTE HOLDER	TE	A
613	2D		B07-1991-03	ESCUTCHEON CASSETTE HOLDER	KPYMX	B
613	2D		B07-1996-03	ESCUTCHEON CASSETTE HOLDER	TE	B
618	2D		B43-0287-04	KENWOOD BADGE		
-	-		B58-0513-04	CAUTION CARD (PRESET220-240)	Y	
-	-	*	B60-0777-00	INSTRUCTION MANUAL (ENGLISH)		
-	-	*	B60-0778-00	INSTRUCTION MANUAL (FRENCH)	PE	
-	-	*	B60-0779-00	INSTRUCTION MANUAL (CHINESE)	M	
-	-	*	B60-0780-00	INSTRUCTION MANUAL (GE, DU, IT)	E	
-	-	*	B60-0830-00	INSTRUCTION MANUAL (SPANISH)	M	
620	1E, 1F		D39-0176-05	DAMPER		
△ 622	2F		E03-0102-25	AC INLET	YM	
△ 623	1E		E03-0115-05	AC PLUG ADAPTER	M	
△ 624	2F		E30-0459-05	AC POWER CORD	E	
△ 624	2F		E30-0974-05	AC POWER CORD	KP	
△ 624	2F		E30-1305-15	AC POWER CORD (INLET)	Y	
△ 624	2F		E30-1329-05	AC POWER CORD (INLET)	M	
△ 624	2F		E30-1341-05	AC POWER CORD	X	
△ 624	2F		E30-1416-05	AC POWER CORD	T	
625	1D		E30-0505-05	AUDIO CORD		
626	1E		E30-1392-05	CORD WITH PLUG		
627	1E		E35-0083-05	FLAT CABLE (X25CN1-X28CN4)		
630	2F		G01-3417-14	TORSION COIL SPRING		A
631	2F		G01-3418-14	TORSION COIL SPRING		B
632	1D, 2E		G02-0944-04	FLAT SPRING		
-	-	*	H50-0271-04	ITEM CARTON CASE		
-	-		H10-5101-12	POLYSTYRENE FOAMED FIXTURE		
-	-		H10-5102-12	POLYSTYRENE FOAMED FIXTURE		
-	-		H20-0554-04	PROTECTION COVER	M	
-	-		H25-0232-04	PROTECTION BAG (235X350X0.03)	KPYMXE	
-	-		H25-0330-04	PROTECTION BAG	KPYXE	
-	-		H25-0651-04	PROTECTION BAG (0232 PRINTED)	T	
-	-		H25-0658-04	PROTECTION BAG (0330 PRINTED)	T	
635	2E, 2F		J02-1034-05	FOOT		
636	2E		J21-3326-05	JACK MOUNTING HARDWARE		
637	2F		J42-0083-05	POWER CORD BUSHING		KPXTE
-	-		J61-0307-05	WIRE BAND		
640	1E	*	K29-4366-02	KNOB TAPE CONTROL		
641	1E		K29-4149-04	KNOB EJECT		
642	2E		K29-4130-04	KNOB REC BALANCE, REC LEVEL		

L:Scandinavia K:USA P:Canada
Y:PX(Far East, Hawaii) T:England E:Europe
Y:AAFES(Europe) X:Australia M:Other Areas

A: A DECK
B: B DECK
△ indicates safety critical components.

* New Parts

Parts without Parts No. are not supplied.

Les articles non mentionnés dans le Parts No. ne sont pas fournis.

Teile ohne Parts No. werden nicht geliefert.

No.2

Ref. No. 参照番号	Address 位置	New Parts 新	Parts No. 部品番号	Description 部品名/規格	Desti- nation 仕向	Re- marks 備考
644	1D, 2E		K29-4141-03	KNOB MECHANISM CONTROL		
△ 650	2E		L07-0256-05	POWER TRANSFORMER		KP
△ 650	2E		L07-0257-05	POWER TRANSFORMER		YM
△ 650	2E		L07-0258-05	POWER TRANSFORMER		XTE
A	1D, 2F		N89-3008-45	BINDING HEAD TAPTITE SCREW		
B	1F, 2F		N89-3008-46	BINDING HEAD TAPTITE SCREW		
C	2E		N86-4006-46	BINDING HEAD TAPTITE SCREW		
D	1E, 1F		N09-1532-05	TAPTITE SCREW (M2X6)		
DISPLAY UNIT (X25-4310-10)						
D32			B30-1291-05	LED(LN21CPSLX(V)-(TA4))		
C1 ,2			CE04KW1V100M	ELECTRO 10UF 35WV		
C3 ,4			CE04KW1H010M	ELECTRO 1.0UF 50WV		
C5			CE04KW1A101M	ELECTRO 100UF 10WV		
C6			CE04KW1V100M	ELECTRO 10UF 35WV		
C7 ,8			CE04KW1V4R7M	ELECTRO 4.7UF 35WV		
C9 ,10			CE04KW1V100M	ELECTRO 10UF 35WV		
C11 ,12			CE04KW1C470M	ELECTRO 47UF 16WV		
C13			CE04KW1C330M	ELECTRO 33UF 16WV		
C14			CE04KW1V100M	ELECTRO 10UF 35WV		
C15			CE04KW1H010M	ELECTRO 1.0UF 50WV		
J1			E11-0199-05	PHONE JACK HEAD PHONE		
VR1			R06-4079-05	POTENTIOMETER REC LEVEL		
VR2			R01-5065-05	POTENTIOMETER REC BALANCE		
S1 -16			S40-1064-05	PUSH SWITCH		
S17 -19			S31-1036-05	SLIDE SWITCH TIMER, DOLBY, DIREC		
S20 -29			S40-1064-05	PUSH SWITCH		
D1 -31			HSS104	DIODE		
D1 -31			1SS133	DIODE		
ED1			BC-952GK	FLUORESCENT INDICATOR TUBE		
IC1			NJM4565D-D	IC(OP AMP X2)		
IC1			RC4565D-D	IC(OP AMP X2)		
Q1 ,2			2SC1740S(Q,R)	TRANSISTOR		
Q1 ,2			2SC3311A(Q,R)	TRANSISTOR		
Q3 ,4			2SC1845(F,E)	TRANSISTOR		
Q5 ,6			2SC1740S(Q,R)	TRANSISTOR		
Q5 ,6			2SC3311A(Q,R)	TRANSISTOR		
RECORD/PLAYBACK UNIT (X28-2310-10: K, P, Y, M, X, 0-11: T, E)						
C1 ,2			CC45FSL1H151J	CERAMIC 150PF J		
C3 ,4			CK45FB1H681K	CERAMIC 680PF K		
C5 ,6			CK45FB1H561K	CERAMIC 560PF K		
C7 -10			CE04KW1C220M	ELECTRO 22UF 16WV		
C11 -14			CE04KW1H010M	ELECTRO 1.0UF 50WV		
C15 -18			CK45FB1H391K	CERAMIC 390PF K		
C19 -22			CQ92FM1H123J	MYLAR 0.012UF J		
C23 ,24			CE04KW1C101M	ELECTRO 100UF 16WV		
C25 ,26			CC45FSL1H271J	CERAMIC 270PF J		
C27 ,28			CE04KW1H010M	ELECTRO 1.0UF 50WV		
C29 ,30			CC45FSL1H101J	CERAMIC 100PF J		
C31 -34			CE04KW1H010M	ELECTRO 1.0UF 50WV		
C35 ,36			CE04KW1V4R7M	ELECTRO 4.7UF 35WV		
C37 ,38			CE04KW1H010M	ELECTRO 1.0UF 50WV		
C39 ,40			CE04KW1V100M	ELECTRO 10UF 35WV		

L:Scandinavia K:USA P:Canada
Y:PX(Far East, Hawaii) T:England E:Europe
Y:AAFES(Europe) X:Australia M:Other Areas

A: A DECK
B: B DECK
△ indicates safety critical components.

PARTS LIST

KX-W8040

× New Parts

Parts without Parts No. are not supplied.

Les articles non mentionnés dans le Parts No. ne sont pas fournis.

Teile ohne Parts No. werden nicht geliefert.

No.3

Ref. No. 参照番号	Address 位置	New Parts 新	Parts No. 部品番号	Description 部品名 / 規格	Desti- nation 向	Re- marks 備考
C41, 42			CK45FB1H392K	CERAMIC 3900PF K		
C43, 44			CC45FSL1H221J	CERAMIC 220PF J		
C45			CQ92FM1H472J	MYLAR 4700PF J		
C46			CE04KW1C331M	ELECTR0 330UF 16WV		
C47 -50			CE04KW1H010M	ELECTR0 1.0UF 50WV		
C51			CE04KW1C220M	ELECTR0 22UF 16WV		
C52 -54			CE04KW1V4R7M	ELECTR0 4.7UF 35WV		
C55 -60			CQ92FM1H222J	MYLAR 2200PF J		
C61 -64			CE04KW1H0R1M	ELECTR0 0.1UF 50WV		
C65, 66			CE04KW1C220M	ELECTR0 22UF 16WV		
C67, 68			CF92FV1H333J	MF 0.033UF J		
C69, 70			CK45FF1H333Z	CERAMIC 0.033UF Z		
C71, 72			CK45FF1H472Z	CERAMIC 4700PF Z		
C73			CC45FSL1H221J	CERAMIC 220PF J		
C74			CC45FSL1H181J	CERAMIC 180PF J		
C75 -80			CE04KW1V4R7M	ELECTR0 4.7UF 35WV		
C81 -84			CE04KW1A101M	ELECTR0 100UF 10WV		
C85 -88			CE04KW1H2R2M	ELECTR0 2.2UF 50WV		
C89, 90			CE04KW1C101M	ELECTR0 100UF 16WV		
C91 -94			CE04KW1H010M	ELECTR0 1.0UF 50WV		
C95, 96			CE04KW1V100M	ELECTR0 10UF 35WV		
C97			CE04KW1H2R2M	ELECTR0 2.2UF 50WV		
C98			CE04KW1H2R2M	ELECTR0 2.2UF 50WV		
C99, 100			CC45FSL1H101J	CERAMIC 100PF J		
C101, 102			CK45FF1H103Z	CERAMIC 0.010UF Z		
C105			CE04KW1V222M	ELECTR0 2200UF 35WV		
C106			CE04KW1C101M	ELECTR0 100UF 16WV		
C107			CE04KW1V470M	ELECTR0 47UF 35WV		
C108			CE04KW1H470M	ELECTR0 47UF 50WV		
C109			CE04KW1J470M	ELECTR0 47UF 63WV		
C110-112			CE04KW1V100M	ELECTR0 10UF 35WV		
C113, 114			CE04KW1A102M	ELECTR0 1000UF 10WV		
C115			CE04KW1H010M	ELECTR0 1.0UF 50WV		
C116			CE04KW1A221M	ELECTR0 220UF 10WV		
C117			CE04KW0J471M	ELECTR0 470UF 6.3WV		
C118			CE04KW1E102M	ELECTR0 1000UF 25WV		
C119, 120			CE04KW1C101M	ELECTR0 100UF 16WV		
C121			CE04KW1V100M	ELECTR0 10UF 35WV		
C122			CE04KW1H010M	ELECTR0 1.0UF 50WV		
C123			CE04KW1V100M	ELECTR0 10UF 35WV		
C124-126			CE04KW1A101M	ELECTR0 100UF 10WV		
C127			CK45FF1H223Z	CERAMIC 0.022UF Z		
C128			CC45FSL1H270J	CERAMIC 27PF J		
C129			CK45FF1H223Z	CERAMIC 0.022UF Z		
C130			CE04KW1H010M	ELECTR0 1.0UF 50WV		
C131, 132			CE04KW1V100M	ELECTR0 10UF 35WV		
C133-136			CE04KW1H3R3M	ELECTR0 3.3UF 50WV		
C137, 138			CE04KW1H010M	ELECTR0 1.0UF 50WV		
C139			CK45FF1H223Z	CERAMIC 0.022UF Z		
C140			CE04KW1A101M	ELECTR0 100UF 10WV		
C141			CE04KW0J222M	ELECTR0 2200UF 6.3WV		
C142, 143			CK45FF1H223Z	CERAMIC 0.022UF Z		
C144			CE04KW1A101M	ELECTR0 100UF 10WV		
C145, 146			CE04KW1H2R2M	ELECTR0 2.2UF 50WV		
C147, 148			CK45FB1H122K	CERAMIC 1200PF K		

L:Scandinavia K:USA P:Canada
Y:PX(Far East, Hawaii) T:England E:Europe
Y:AAFES(Europe) X:Australia M:Other Areas

A: A DECK
B: B DECK
△ indicates safety critical components.

× New Parts

Parts without Parts No. are not supplied.

Les articles non mentionnés dans le Parts No. ne sont pas fournis.

Teile ohne Parts No. werden nicht geliefert.

No.4

Ref. No. 参照番号	Address 位置	New Parts 新	Parts No. 部品番号	Description 部品名 / 規格	Desti- nation 向	Re- marks 備考
C149, 150			CK45FB1H332K	CERAMIC 3300PF K		
C151, 152			CE04KW1C220M	ELECTR0 22UF 16WV		
C153, 154			CE04KW1H2R2M	ELECTR0 2.2UF 50WV		
C155-158			CC45FSL1H221J	CERAMIC 220PF J		
C159, 160			CC45FSL2H100D	CERAMIC 10PF D		
C161-164			C91-1434-05	FILM 150PF J		
C165-168			C91-1436-05	FILM 220PF J		
C169-172			CK45FB1H471K	CERAMIC 470PF K		
C173-176			CK45FF1H103Z	CERAMIC 0.010UF Z		
C177-180			CF92FV1H823J	MF 0.082UF J		
C181-184			CK45FF1H223Z	CERAMIC 0.022UF Z		
C185-188			CE04KW1HR47M	ELECTR0 0.47UF 50WV		
C189, 190			CK45FF1H103Z	CERAMIC 0.010UF Z		
C191-194			CK45FB1H392K	CERAMIC 3900PF K		
C195, 196			CE04KW1C220M	ELECTR0 22UF 16WV		
C197, 198			CQ93HP2A103J	MYLAR 0.010UF J		
C199			CK45FF1H103Z	CERAMIC 0.010UF Z		
J1			E13-0445-05	PHONE JACK LINE IN/OUT		
J2			E11-0168-05	MINIATURE PHONE JACK SYNCRO		
-			J11-0098-05	WIRE CLAMPER		
L1, 2			L79-0720-05	LC FILTER		
L3, 4			L32-0388-05	BIAS OSCILATING COIL		
L5 -8			L32-0377-05	BIAS OSCILATING COIL		
L9 -16			L40-1035-29	SMALL FIXED INDUCTOR(10MH, J)		
X1			L78-0244-05	RESONATOR 4MHz		
CP1			R90-0818-05	MULTIPLE RESISTOR		
R221, 222			RS14KB3D330J	FL-PROOF RS 33 J 2W		
VR1 -4			R12-0605-05	TRIMMING POT.(220)		
VR5 -8			R12-3688-05	TRIMMING POT.(47K)		
VR9, 10			R12-3685-05	TRIMMING POT.(10K)		
K1, 2			S51-2089-05	MAGNETIC RELAY		
D1			KBP02ML-6127	DIODE		
D2 -5			SS688B	DIODE		
D2 -5			1SR139-100	DIODE		
D6 -8			HSS104	DIODE		
D6 -8			1SS133	DIODE		
D9 -12			SS688B	DIODE		
D9 -12			1SR139-100	DIODE		
D13 -15			HZS2.7N(B2)	ZENER DIODE		
D13 -15			RD2.7ES(B2)	ZENER DIODE		
D16			HZS4.7N(B)	ZENER DIODE		
D16			RD4.7ES(B)	ZENER DIODE		
D17			HZS6.2N(B2)	ZENER DIODE		
D17			RD6.2ES(B2)	ZENER DIODE		
D18			HZS13N(B2)	ZENER DIODE		
D18			RD13ES(B2)	ZENER DIODE		
D19			HZS24N(B)	ZENER DIODE		
D19			RD24ES(B)	ZENER DIODE		
D20 -29			HSS104	DIODE		
D20 -29			1SS133	DIODE		
D30, 31			RB721Q	DIODE		
D32 -79			HSS104	DIODE		

L:Scandinavia K:USA P:Canada
Y:PX(Far East, Hawaii) T:England E:Europe
Y:AAFES(Europe) X:Australia M:Other Areas

A: A DECK
B: B DECK
△ indicates safety critical components.

KX-W8040

PARTS LIST

* New Parts

Parts without Parts No. are not supplied.

Les articles non mentionnés dans le Parts No. ne sont pas fournis.

Teile ohne Parts No. werden nicht geliefert.

No. 5

Ref. No. 参照番号	Address 位置	New Parts 新	Parts No. 部品番号	Description 部品名 / 規格	Desti- nation 仕向	Re- marks 備考
D32 -79 IC1 IC2 IC3 -5 IC6		*	1SS133 M50945-129SP HA12170NT CXD1067P TC9213P	DIODE IC(MICROPROCESSOR) IC(DOLBY B/C NR) IC(SERIAL-PARALLEL CONVERTER) IC(2CH ELECTRONIC VOLUME)		
IC7 ,8 IC9 ,10 IC11,12 IC11,12 IC13,14			UPC1297CA CXAI198AP TC4051BP XRU4051B TC4052BP	IC(DOL HX PRØ SYSTEM) IC(CASSETTE DECK REC EQUALIZER) IC(8CH MPX/ DE-MPX) IC(MULTIPLEXERS/DEMULTIPLEXERS) IC(4CH MPX/DE-MPX)		
IC13,14 IC15-17 IC18-20 IC21,22 IC23	f2>0B		XRU4052B TD62554S BA10393 TA8125S NJM4558D	IC(ANALOG MULTIPLEXER/DEMULTIP IC(4CH TRANSISTOR ARRAY) IC(DUAL COMPALATOR) IC(2CH PRE AMP) IC(OP AMP X2)		
IC24-26 IC24-26 IC24-26 IC27 Q1		*	BA15218-DX NJM4565D-D RC4565D-D UPC7815HF 2SD1266(Q,P)	IC IC(OP AMP X2) IC(OP AMP X2) IC(VOLTAGE REGULATOR/ +15V) TRANSISTOR		
Q2 Q3 -5 Q6 ,7 Q9 -12 Q9 -12			2SA999(E,F) 2SC3940A 2SC3246 2SA1309A(Q,R) 2SA933S(Q,R)	TRANSISTOR TRANSISTOR TRANSISTOR TRANSISTOR TRANSISTOR		TE TE
Q11 ,12 Q11 ,12 Q13 -32 Q13 -32 Q13 ,14			2SA1309A(Q,R) 2SA933S(Q,R) 2SC1740S(Q,R) 2SC3311A(Q,R) 2SC1740S(Q,R)	TRANSISTOR TRANSISTOR TRANSISTOR TRANSISTOR TRANSISTOR		KPYMX KPYMX TE TE KPYMX
Q13 ,14 Q17 -32 Q17 -32 Q33 -39 Q33 -39			2SC3311A(Q,R) 2SC1740S(Q,R) 2SC3311A(Q,R) DTA124ES UN4112	TRANSISTOR TRANSISTOR TRANSISTOR DIGITAL TRANSISTOR TRANSISTOR		KPYMX KPYMX KPYMX
Q40 -62 Q40 -62			DTC124ES UN4212	DIGITAL TRANSISTOR TRANSISTOR		
MECHANISM ASS'Y (D40-0965-05: A DECK: K, P, Y, M, X 6-05: B DECK: K, P, Y, M, X, 7-05: A DECK: T, E, 8-05 B DECK: T, E)						
301 302 303 305 306	1C 1C 2A, 2B 1C 1A, 2B		D01-0118-08 D01-0119-08 D03-0231-08 D10-3201-08 D10-3121-08	FLY WHEEL ASSY FLY WHEEL ASSY REEL DISK ASSY SLIDER ASSY LEVER (REC, CrØ2)		
307 307 308 309 310	1B, 2B 2B 1C 2A 1B	*	D10-2336-08 D10-2369-08 D10-3202-08 D10-3205-08 D10-2340-08	LEVER (METAL) LEVER (METAL) PLAY ARM SLIDER RØD (PLUNGER)		B A
311 312 312 313 313	2B 1B, 2B 1B, 2B 2A, 2B 2A, 2B		D10-2341-08 D10-2342-08 D10-2476-08 D10-2474-08 D10-2475-08	RØD (CØRE) LEVER (PACK) LEVER (PACK) TENSION ARM TENSION ARM		B A B A
314	1C		D13-0941-08	GEAR ASSY		

L:Scandinavia K:USA P:Canada
Y:PX(Far East, Hawaii) T:England E:Europe
Y:AAFES(Europe) X:Australia M:Other Areas

A: A DECK
B: B DECK
△ indicates safety critical components.

* New Parts

Parts without Parts No. are not supplied.

Les articles non mentionnés dans le Parts No. ne sont pas fournis.

Teile ohne Parts No. werden nicht geliefert.

No. 6

Ref. No. 参照番号	Address 位置	New Parts 新	Parts No. 部品番号	Description 部品名 / 規格	Desti- nation 仕向	Re- marks 備考
315 317 317 318 319	2B 2C 1A 2A 2A		D14-0304-08 D32-0192-08 D32-0193-08 D40-0928-08 D10-3204-08	TØLER ASSY EJECT LEVER ASSY EJECT LEVER ASSY HEAD BASE HEAD BASE ASSY		A B
319 320 321 323 325	2A 2A 2B 2B 2A		D10-3206-08 E31-7444-08 E31-7945-08 F10-0780-08 G01-2398-08	HEAD BASE ASSY QS LEAD WIRE CONNECTING WIRE SHIELDING PLATE TENSION SP		KPYMX TE
326 327 327 328 330	2C 1B, 2B 1B, 2B 1B 2B		G01-2400-08 G01-2422-08 G01-3341-08 G02-0947-08 G16-0764-08	TØRSION SP TENSION SP TENSION SP FLAT SPRING REFLECTING PLATE		B A
332 333 335 336 337	2B 2A 2A 2A 1B, 2B		J19-3253-08 J25-6285-08 N09-2863-08 N09-2585-08 N09-2700-08	LEAD HOLDER HEAD WIRE SCREW SCREW (M2X 5) SCREW (M2.6X 5)		
338 339 340 341 342	2B 2A 1B, 2B 1A, 2C 2A		N09-2701-08 N09-2710-08 N09-2698-08 N09-2730-08 N19-0904-08	SCREW (3X 8) SCREW (M1.6X 6) SCREW (M2.6X 6.4) SCREW (M2X 9) FLAT WASHER (1.7X 0.25)		
343 344 345 346 350	1C 2A, 2B 2B 2B 1B, 2B		N19-0905-08 N19-1095-08 N19-1214-08 N29-0205-04 T94-0216-08	FLAT WASHER (2.6X 0.25) FLAT WASHER (2.1X 0.25) FLAT WASHER (2.6X 0.5) E TYPE RETAINING RING SOLENOID		
351 352 374 374 374	2A 1B 1B 1B 1B		T95-0117-08 T95-0120-08 W02-1123-08 W02-1124-08 W02-1125-08	QUICK SENSOR PHØTØ SENSOR PRINTED WIRING BOARD PRINTED WIRING BOARD PRINTED WIRING BOARD		A B A A
374 BM MM PF PR	1B 1C 1C 2B 2A		W02-1126-08 D16-0287-08 T42-0535-08 D14-0311-08 D14-0312-08	PRINTED WIRING BOARD BELT DC MØTØR ASSY (MAIN) PINCH RØLLER ASSY PINCH RØLLER ASSY		B
RM RPEH S1 -55	1B 2A 1B, 1C		T42-0534-08 T39-0019-08 S90-0105-08	DC MØTØR ASSY (REEL) REC/PB/ERASE HEAD PUSH SWITCH		
VR1 VR1 VR2 VR2			RH0615C14J R12-3126-05 RH0615CJ4J R12-3128-05	TRIMMING PØT. 10K TRIMMING PØT. 10K TRIMMING PØT. 22K TRIMMING PØT. 22K		
D1 -6 D7 D8 D9 IC1			ERA15-01V5 HZS7B3 HZS4A3 ERA15-01V5 TA7291S	DIODE DIODE DIODE DIODE IC(BRIDGE DRIVER)		
Q1 Q2			2SC3377 2SC4204	TRANSISTOR TRANSISTOR		

L:Scandinavia K:USA P:Canada
Y:PX(Far East, Hawaii) T:England E:Europe
Y:AAFES(Europe) X:Australia M:Other Areas

A: A DECK
B: B DECK
△ indicates safety critical components.

PARTS LIST

KX-W8040

KX-W8040

SPECIFICATIONS

Track System	4-track, 2-channel stereo	
Recording System	AC bias (Frequency: 105 kHz)	
Heads	A DECK	
	Playback/recording head ... 1	
	Erasing head	1
	B DECK	
	Playback/recording head ... 1	
	Erasing head	1
Motors	A DECK	DC motor × 2
	B DECK	DC motor × 2
Fast Winding Time	Approx. 95 seconds (C-60 tape)	
Frequency Response:		
Normal Tape	20 Hz to 18,000 Hz, ± 3 dB	
CrO ₂ Tape	20 Hz to 19,000 Hz, ± 3 dB	
Metal Tape	20 Hz to 20,000 Hz, ± 3 dB	
Signal-to Noise Ratio:		
Dolby C NR ON	72 dB (Metal tape)	
Dolby B NR ON	65 dB (Metal tape)	
Dolby NR OFF	57 dB (Metal tape)	
Harmonic Distortion	Less than 0.6% (at 1 kHz, 3rd H.D., Normal tape)	
Wow and Flutter	0.06% (W.R.M.S.) ± 0.18% (DIN)	
Input sensitivity/Impedance:		
LINE IN	77.5 mV/50 kΩ	
Output Level/Impedance:		
LINE OUT	390 mV/1.9 kΩ	
Headphones	0.2 mW/8 Ω	

[GENERAL]

Power Consumption	35 W
Dimensions	W: 440 mm (17-5/16")
	H: 137 mm (5-3/8")
	D: 269 mm (10-9/16")
Weight (Net)	4.9 kg (10.8 lb)

KENWOOD follows a policy of continuous advancements in development.

For this reason specifications may be changed without notice.

DOLBY and the double-D symbol are trademarks of Dolby Laboratories Licensing Corporation. Noise reduction circuit made under license from Dolby Laboratories Licensing Corporation.

KENWOOD poursuit une politique de progrès constants en ce qui concerne le développement.

Pour cette raison, les spécifications sont sujettes à modifications sans préavis.

La marque DOLBY et le double "D" sont des marques déposées des Dolby Laboratories.

Le système de réduction du bruit de fond est fabriqué sous licence des Dolby Laboratories.

KENWOOD strebt ständige Verbesserungen in der Entwicklung an.

Daher bleiben Änderungen der technischen Daten jederzeit vorbehalten.

DOLBY und Doppel-D-Symbol sind eingetragene Warenzeichen der Dolby Laboratories.

Dolby-Rauschunterdrückung mit Lizenz der Dolby Laboratories gefertigt.

Note:

Component and circuitry are subject to modification to insure best operation under differing local conditions. This manual is based on the U.S.A. (K) standard, and provides information on regional circuit modification through use of alternate schematic diagrams, and information on regional component variations through use of parts list.

KENWOOD CORPORATION

Shionogi Shibuya Building, 17-5, 2-chome Shibuya, Shibuya-ku, Tokyo 150, Japan

KENWOOD U.S.A. CORPORATION
2201 East Dominguez Street, Long Beach, CA 90810;
550 Clark Drive, Mount Olive, NJ 07828, U.S.A.

KENWOOD ELECTRONICS CANADA INC.
P.O. BOX 1075, 959 Gana Court, Mississauga, Ontario, Canada L4T 4C2

TRIO-KENWOOD U.K. LIMITED
KENWOOD House, Dwight Road, Watford, Herts., WD1 8EB United Kingdom

KENWOOD ELECTRONICS BENELUX N.V.
Mechelsesteenweg 418 B-1930 Zaventem, Belgium

KENWOOD ELECTRONICS DEUTSCHLAND GMBH
Rembrücker-Str. 15, 6056 Heusenstamm, Germany

TRIO-KENWOOD FRANCE S.A.
13 Boulevard Ney, 75018 Paris, France

KENWOOD LINEAR S.p.A.
20125, MILANO-VIA ARBE, 50, ITALY

KENWOOD ELECTRONICS AUSTRALIA PTY. LTD. (INCORPORATED IN N.S.W.)
P.O. Box 504, 8 Figtree Drive, Australia Centre, Homebush, N.S.W. 2140, Australia

KENWOOD & LEE ELECTRONICS, LTD
Wang Kee Building, 4th Floor, 34-37, Connaught Road, Central, Hong Kong