

STEREO DOUBLE CASSETTE DECK

KX-W891/W6030

SERVICE MANUAL

REVISED

KENWOOD

©1991-4 PRINTED IN JAPAN
B51-4278-10(S)3678

KX-W891

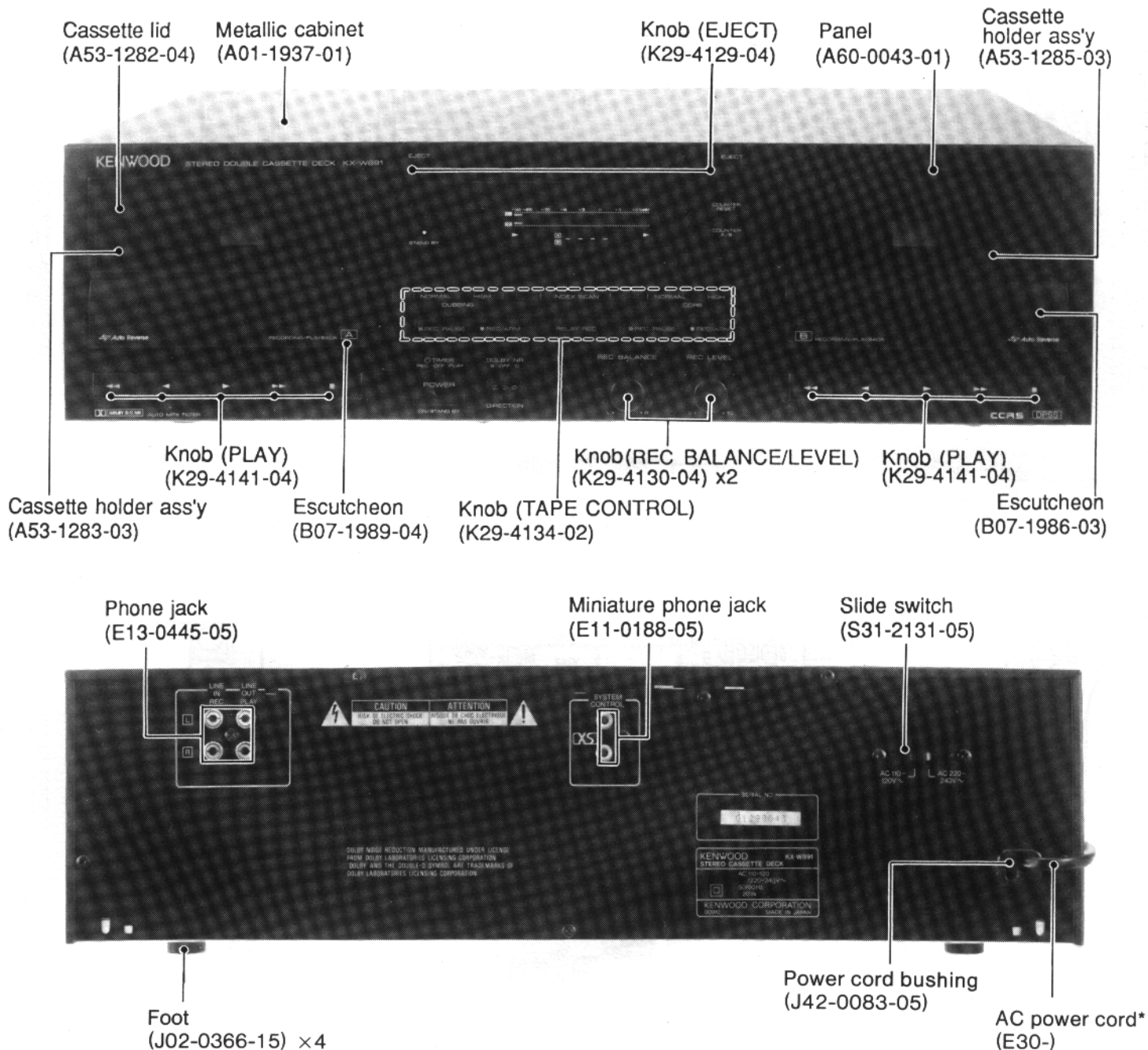

* Refer to parts list on page 15.

The shaded parts on the circuit diagram and on the printed circuit board are different from the original manual.

This manual is applied the serial No. of KX-W891 (10400001) and KX-W6030 (10300001).

PC BOARD (Component side view)

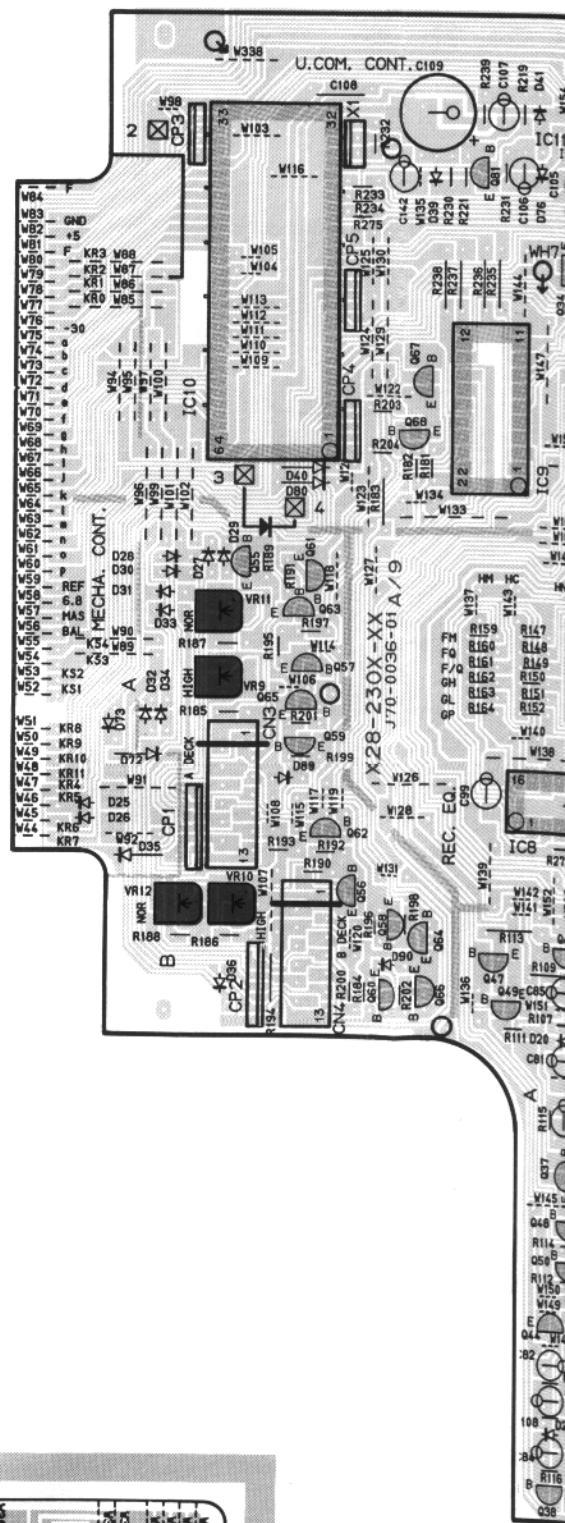
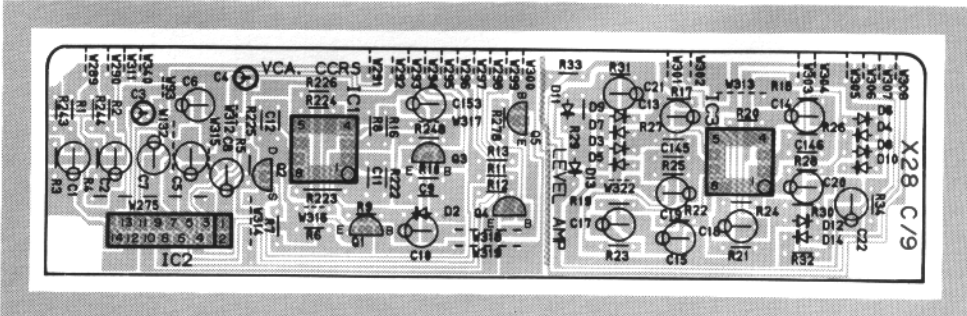
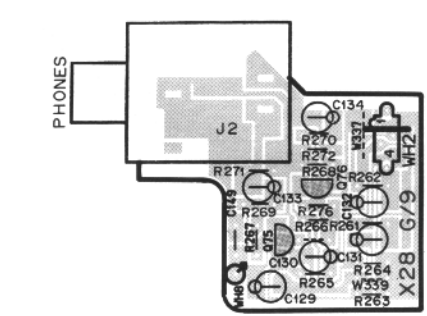
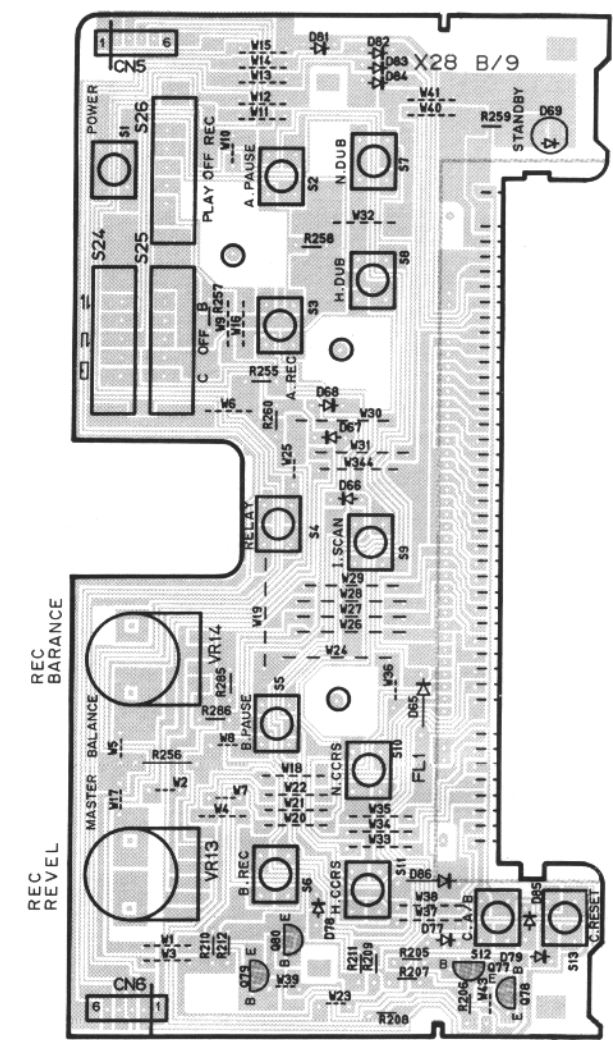
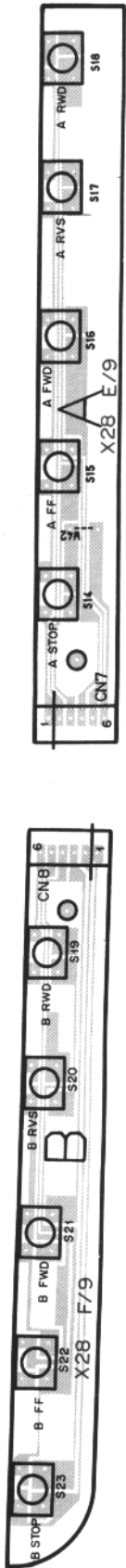

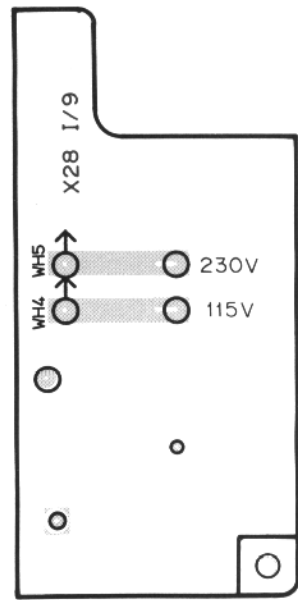
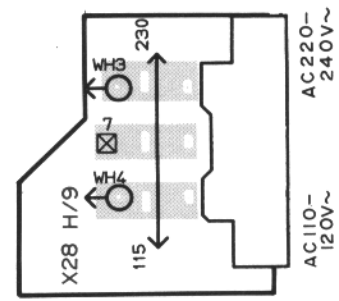
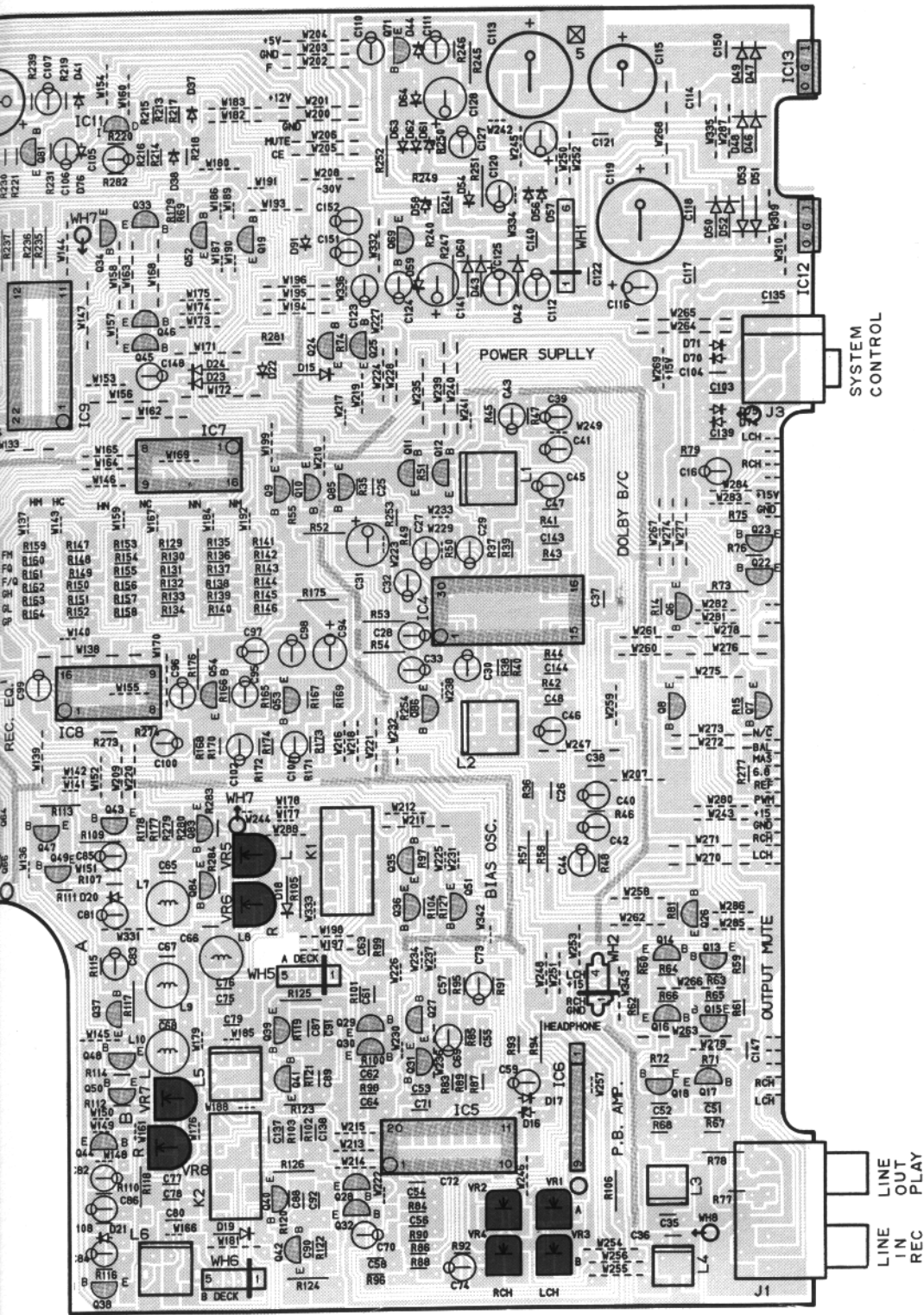

IC4 :HA1217ONT
 IC5 :LA3246
 IC6 :TD62554S
 IC7 :XRU4051B
 or TC4051BP
 IC8 :CXA1198AP

IC9 :MSM59371
 IC10 :MS0946-1035P
 IC11 :PST529D
 IC12 :PC7815HF
 or PC7812HF
 IC13 :PC7812HF

Q8~12, 26~36, UN4212 or DTC124ES
 47~51,
 61~66
 Q43, 44 :DTC143TS
 or AN4216

Q6, 7, 24,
 25, 55, 56
 Q19, 45,
 46, 52

DECK A
 D40-0962-05

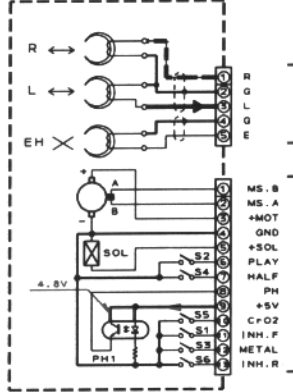

DECK B
 D40-0961-05

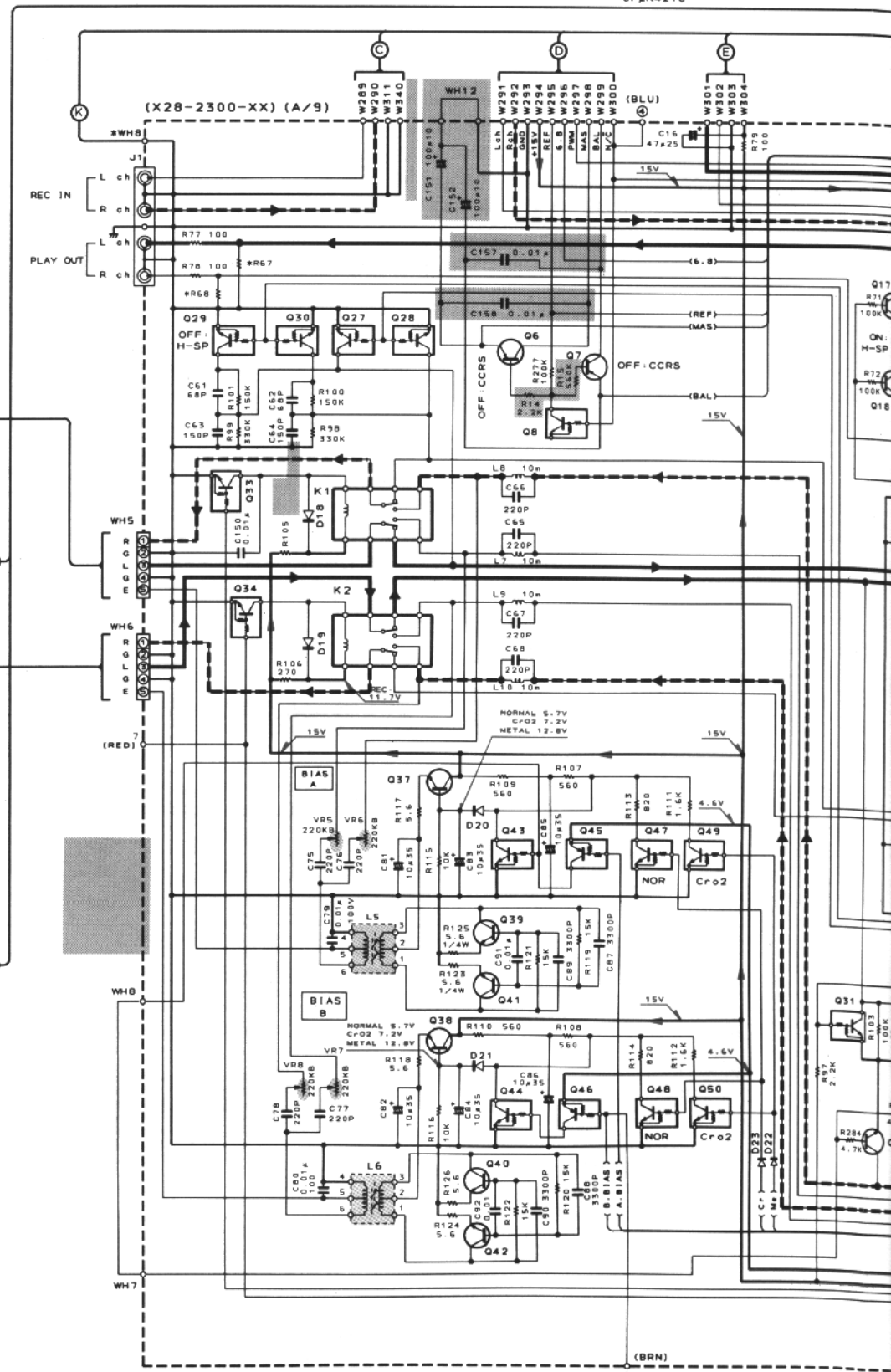
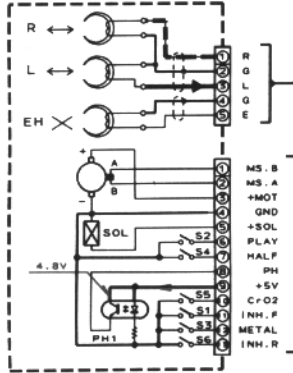

DESTINATION	Ref. No.	*A	WH2	WH8	R67, G8	S27	WH3, 4
KX-W6030	K.P.T.E	Q-12	YES	YES	39K	NO	NO
	Y	Q-13				YES	YES
KX-W891	K.P.X.	Q-10	NO	NO	20K	NO	NO
	Y.M	Q-11				YES	YES

06. 7. 24. : 25A1309A (Q. R) or 25A9335 (Q. R)
 25. 55. 56
 Q19. 45. : UN4112 or DTA124ES
 46. 52

Q13~16. 22. 23. : 25C3311A (Q. R) or 25C1740S (Q. R)
 39~42. 53. 54. 67. 68. 77~81
 83. 84
 Q37. 38. 71 : 25D863 (E. F)
 Q57~60 : 25A1286
 Q85. 86 : 25D1302 (S. T)

Q69 : 25A954 (L. K)
 Q75. 76 : 25C1845 (F. E)

D2~15. 17~24. 27~34. : 15S133 or HSS104
 37~41. 54. 56. 57.
 62~68. 70~84.
 89~95

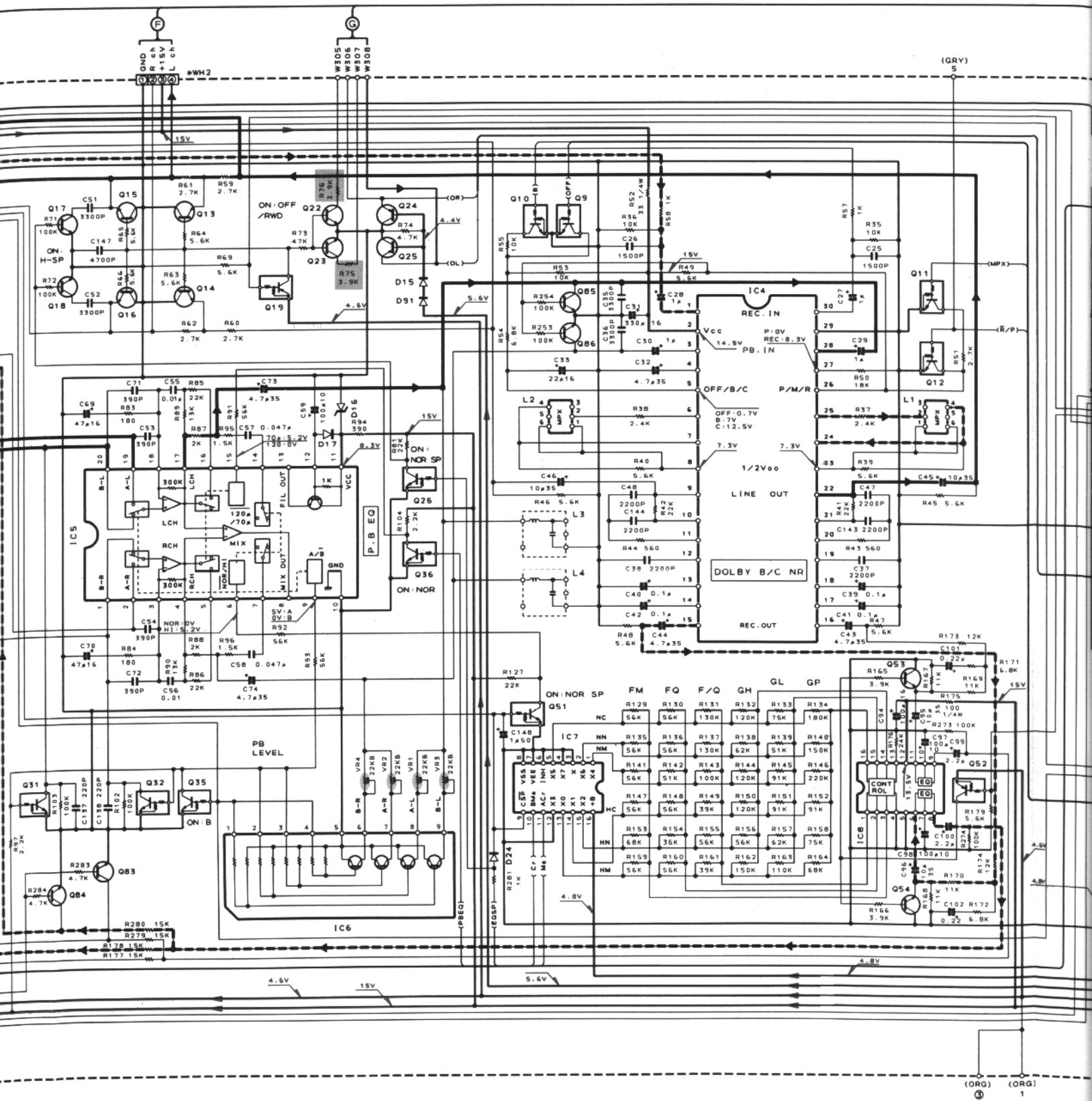

HSS133 or HSS104
 D25. 26. 35. 36
 D42. 43. 60
 D44
 D46
 D46-53

RD8. 2J5 (B2) or HZ58. 25 (B2)
 RB721Q
 HSS104A or ISS131
 RD6. 2E5 (B2) or HZ56. 2N (B2)
 KBP02ML-6127
 S5688B or 15R139-100

D58
 D59
 D61
 RD5. 1E5 (B2) or HZ55. 1N (B2)
 RD30E5 (B) or HZ530N (B)
 RD4. 7E5 (B) or HZ54. 7N (B)

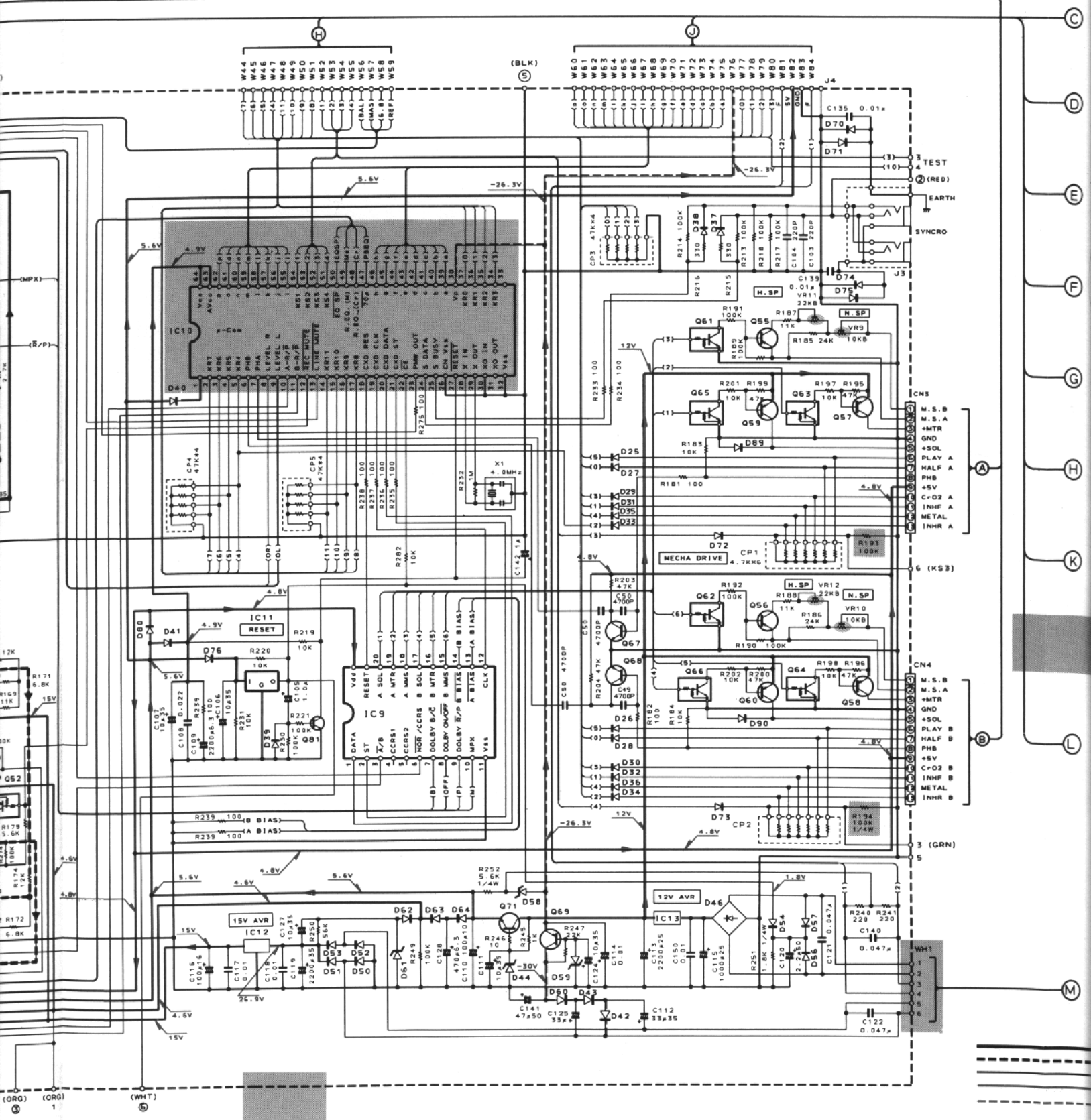

(ORG) 1
 (WHT) 2

C
D
E
F
G
H
K
L
M

2SA1286
2SA954
2SC1845
2SD1302
2SD863

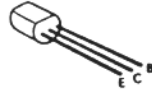

TC4051BP
XRU4051B

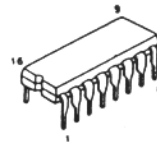

UPC7812HF
UPC7815HF

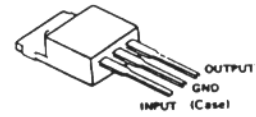

DTA124ES
DTA143TS
DTC124ES
DTC143TS
UN4112
UN4116
2SA933S
2SC1740S

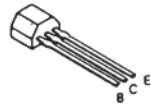

TD62554S

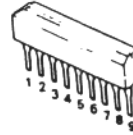

PST529D

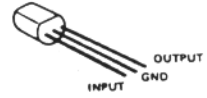

LA3246



2SK364

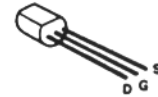

UN4212
UN4216
2SA1309A
2SC3311A

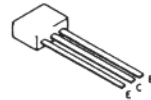

RC4565D

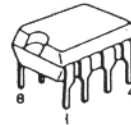

NJM4565D

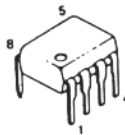

TC74HC02AP
UPD74HC02C

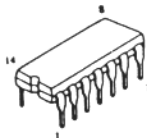

CXA1198AP

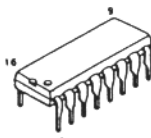

SIGNAL LINE
REC LINE
GND LINE
+B LINE
-B LINE

DC voltages are as measured with a high impedance voltmeter with a cassette loaded at playback mode. Values may vary slightly due to variations between individual instruments or/and units. Bias circuit DC voltages are as measured while in the record mode.

Les tensions c.c. doivent être mesurées avec un voltmètre à haute impédance, une cassette étant insérée en mode de lecture. Les valeurs peuvent différer légèrement du fait des variations inhérentes aux appareils et aux instruments de mesure individuels.

Les tensions c.c. du circuit de polarité doivent être mesurées, l'appareil étant en mode d'enregistrement.

Die angegebenen Gleichspannungswerte wurden bei eingesetzter Cassette in der Wiedergabe mit einem hochohmigen Spannungsmesser gemessen. Dabei schwanken die Meßwerte aufgrund von Unterschieden zwischen einzelnen Instrumenten oder Geräten u. U. geringfügig. Die angegebenen Gleichspannungswerte der Vormagnetisierungsschaltung wurden in der Aufnahme-Betriebsart gemessen.

CAUTION: For continued safety, replace safety critical components only with manufacturer's recommended parts (refer to parts list). **⚠** Indicates safety critical components. To reduce the risk of electric shock, leakage-current or resistance measurements shall be carried out (exposed parts are acceptably insulated from the supply circuit) before the appliance is returned to the customer.

KX-W891

Y26-3240-10

KENW

C
D
E
F
G
H
J
K

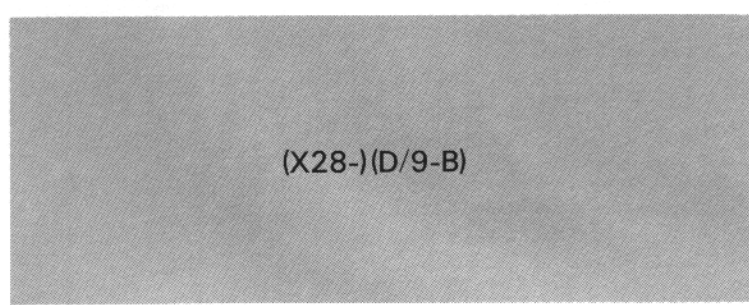
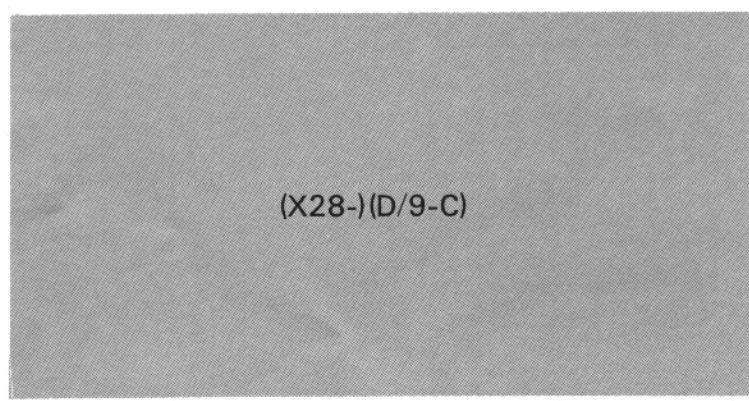
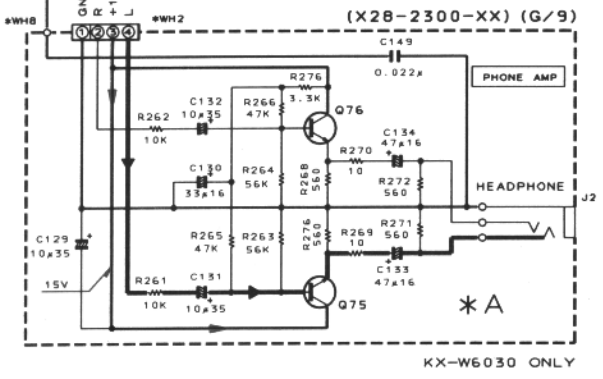

M

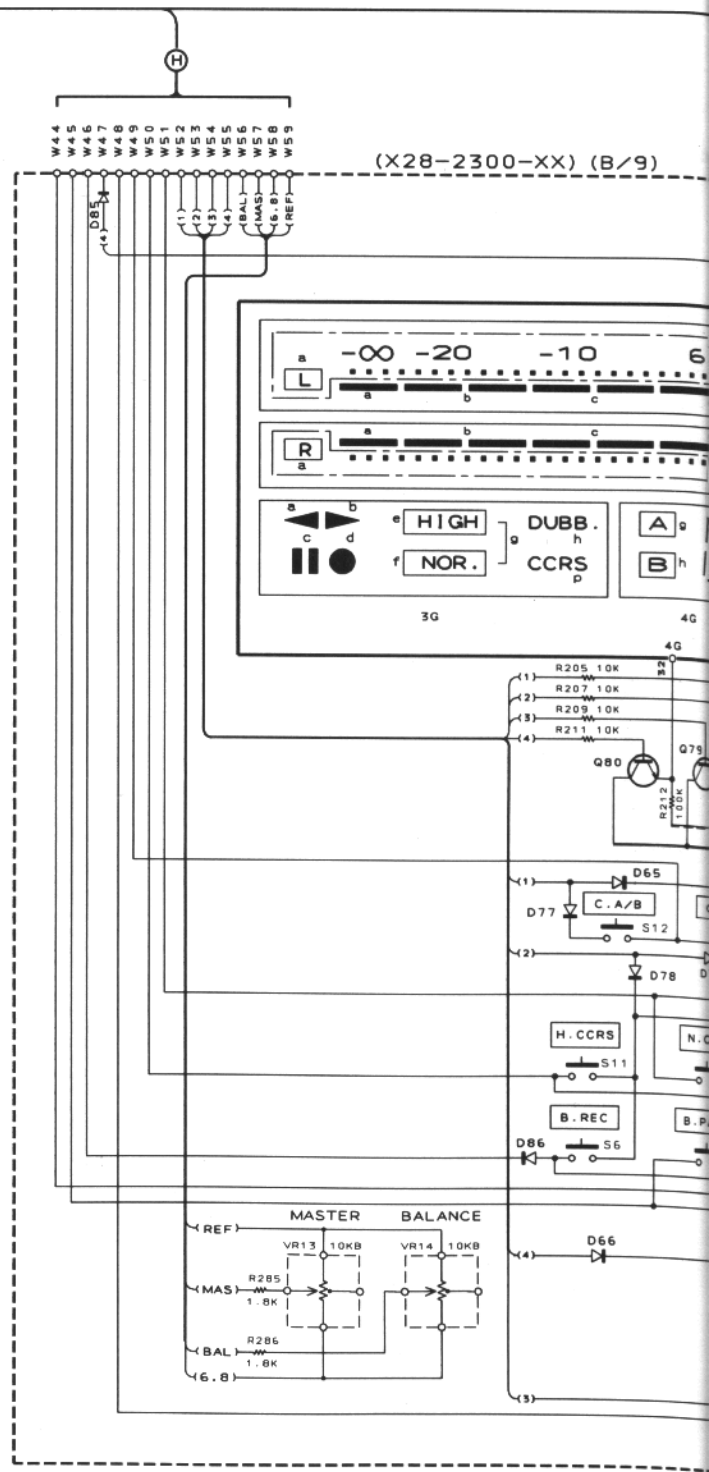

- Q78~80 : 2SC1740S Q.R
Or 2SC3311A QR
- D81~84 : HSS104
Or ISS133
- D69 : B30-1291-05
- D85.86 : RB721Q

(X) (B/9)

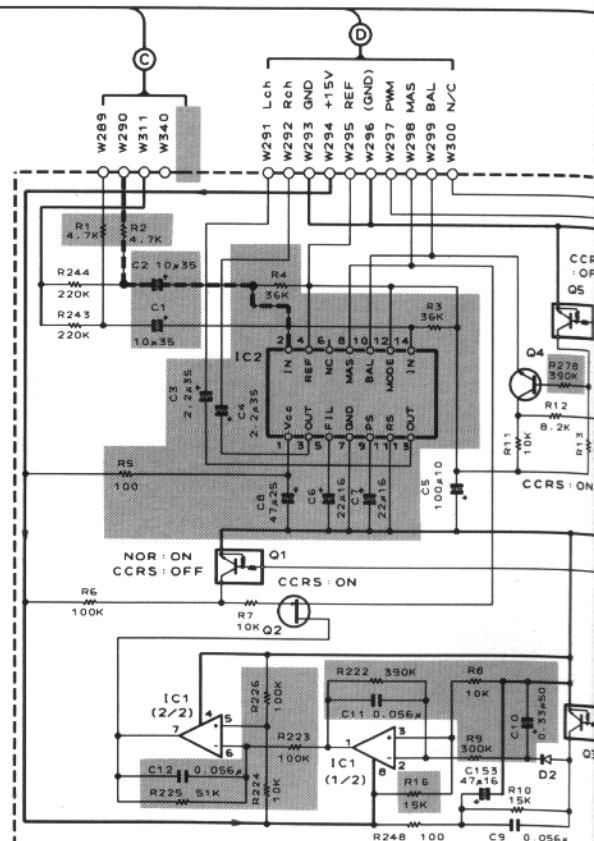
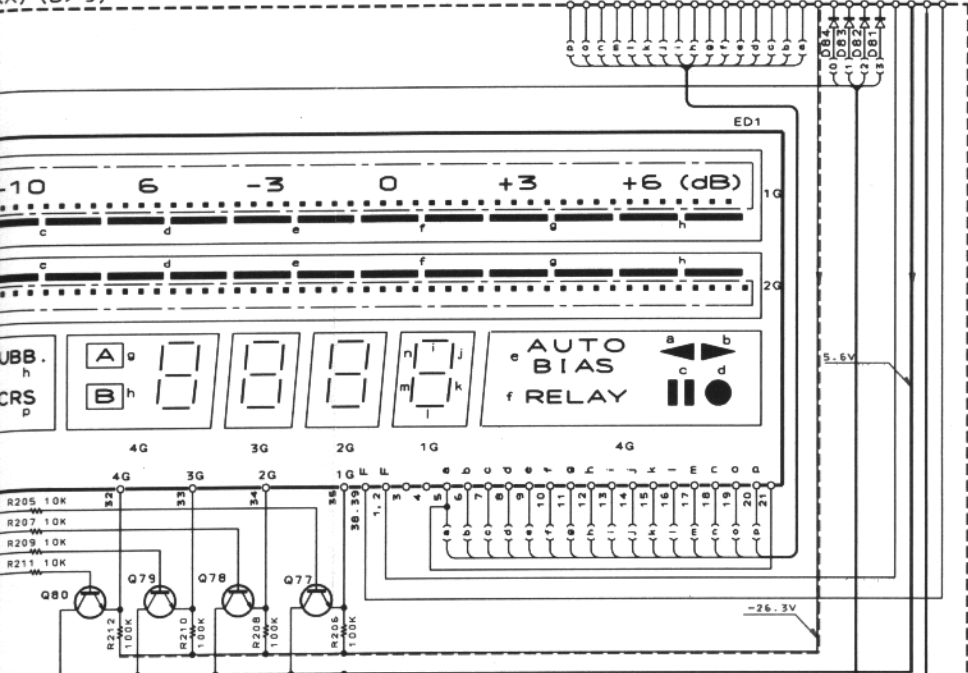

(X28-2300-XX) (E/9)

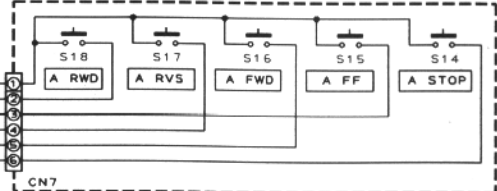

(X28-2300-XX) (F/9)

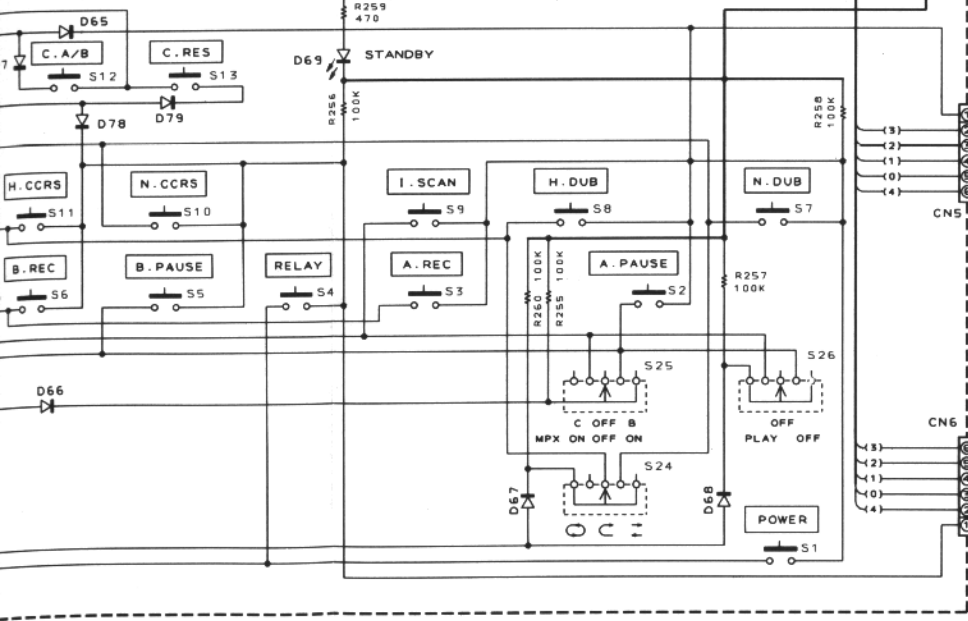
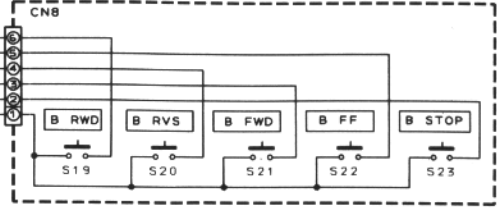

KX-W891/W6030

CIRCUIT DESCRIPTION

Dual-channel electronic volume and balance control Outline

The M51132L is an IC for electronically controlling the volume and balance in a dual-channel audio system. It is housed in a 14-pin molded plastic zigzag inline package, and supports both independent volumen control of the left and right channels, and ganged volume control with balance control. Control is effected by varying the applied DC voltage.

Pin arrangement (top)

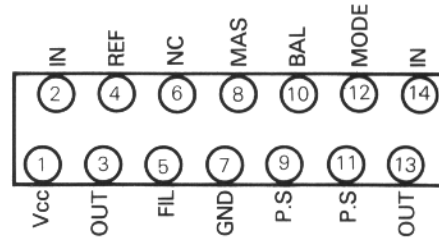

Block diagram

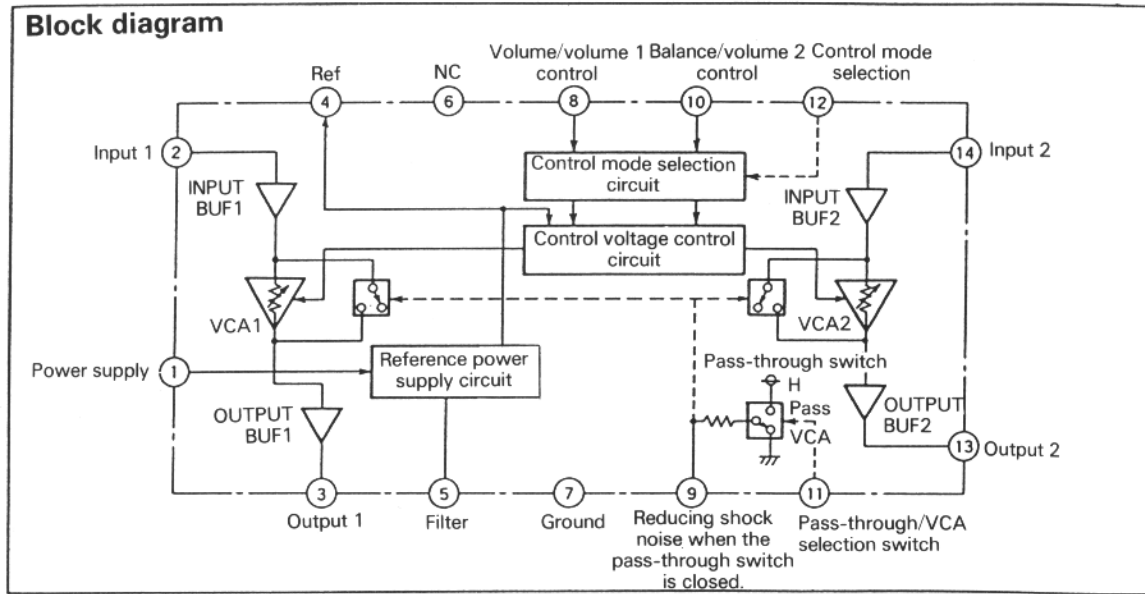

Pin functions

Pin No.	Name	Use	Standard DC voltage
①	Power supply	Apply 8 to 15 VDC. (Rated voltage: 12 V)	
②	Input 1	Maximum permissible input: 3.4 Vrms (standard)	5.5V
③	Output 1		4.8V
④	Reference power supply output	Maximum output current 10 mA (standard). A short-circuit prevention circuit is incorporated.	5.2V
⑤	Filter		12V
⑥	No connection	Can be used relay wiring for grounding.	
⑦	Ground		
⑧	Volume/volume 1 control	On application of 0 to 5.2 VDC, controls the channel 1 and channel 2 volumes in tandem or the channel 1 volume.	
⑨	Reducing shock noise when the pass-through switch is closed.	The switching noise is reduced by providing a time constant (T) and slowly switching between pass-through and VCA. The time constant is determined by an external capacitor (C). $T \text{ (sec)} = 1.2 \times C \times 20k$	5.2 V for pass-through; 0 V for VCA
⑩	Balance/volume 2 control	On application of 0 to 5.2 VDC, controls the balance or the channel 2 volume.	
⑪	Pass-through/VCA switch	0 V: VCA 5.2 V: Input signal is passed through and output as it is.	
⑫	Control mode selection	0 V: Pin 8: Channel 1 volume Pin 10: Channel 2 volume 5.2 V: Pin 8: Channel 1 and 2 volumes Pin 10: Balance	
⑬	Output 2		4.8V
⑭	Input 2	Maximum permissible input: 3.4 Vrms (standard)	5.5V

KX-W891/W6030

EXPLODED VIEW (MECHANISM)

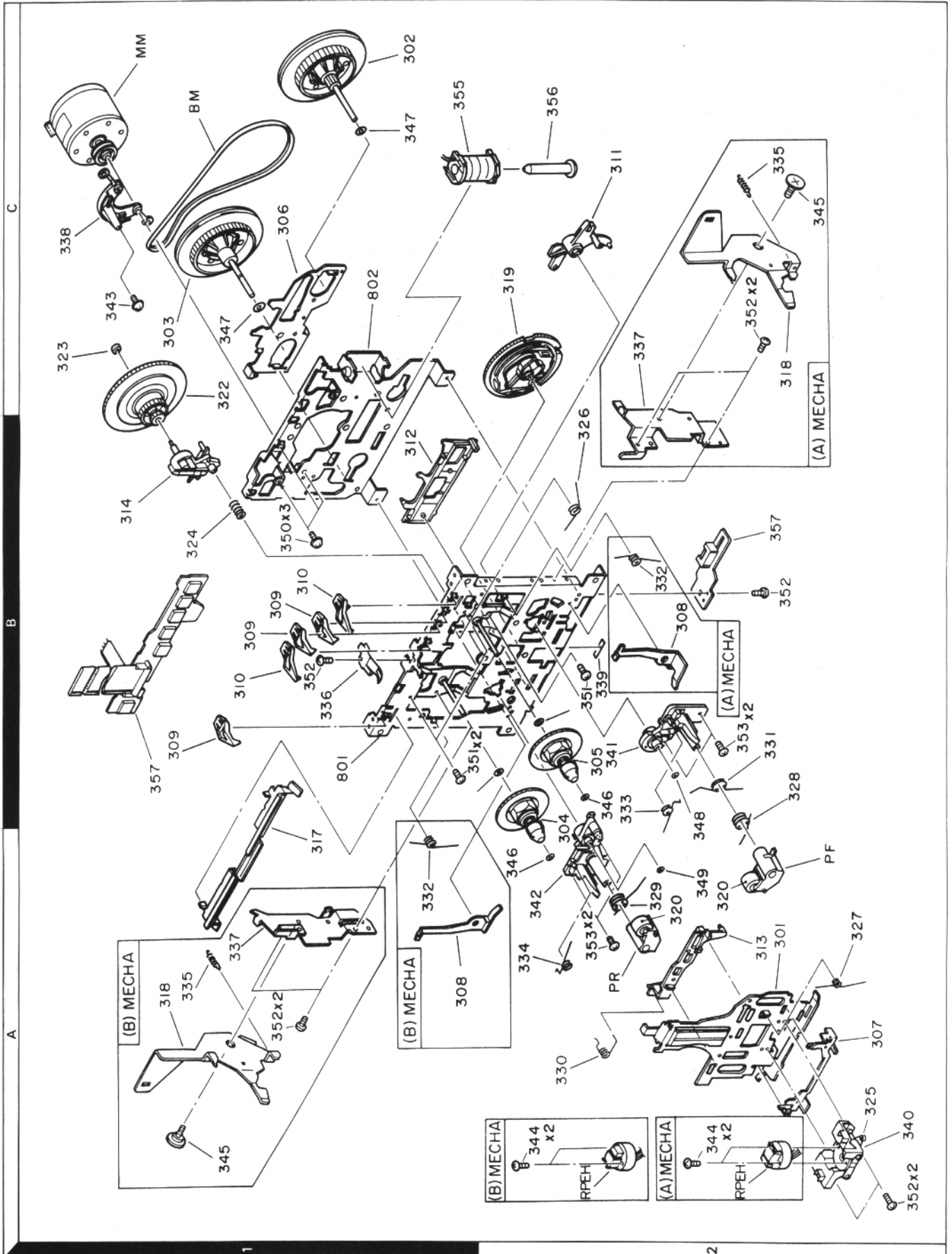

Parts with the exploded numbers larger than 700 are not supplied. 13