

STEREO DOUBLE CASSETTE DECK

KX-W893

SERVICE MANUAL

KENWOOD

©1992-12 PRINTED IN JAPAN
B51-4677-00(S) 2375

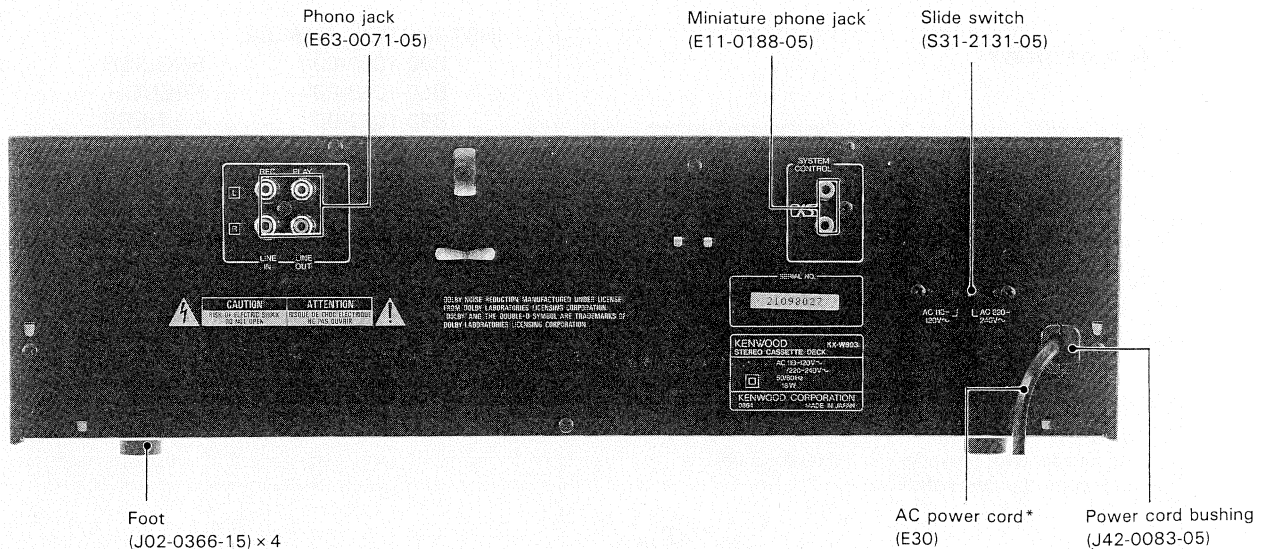
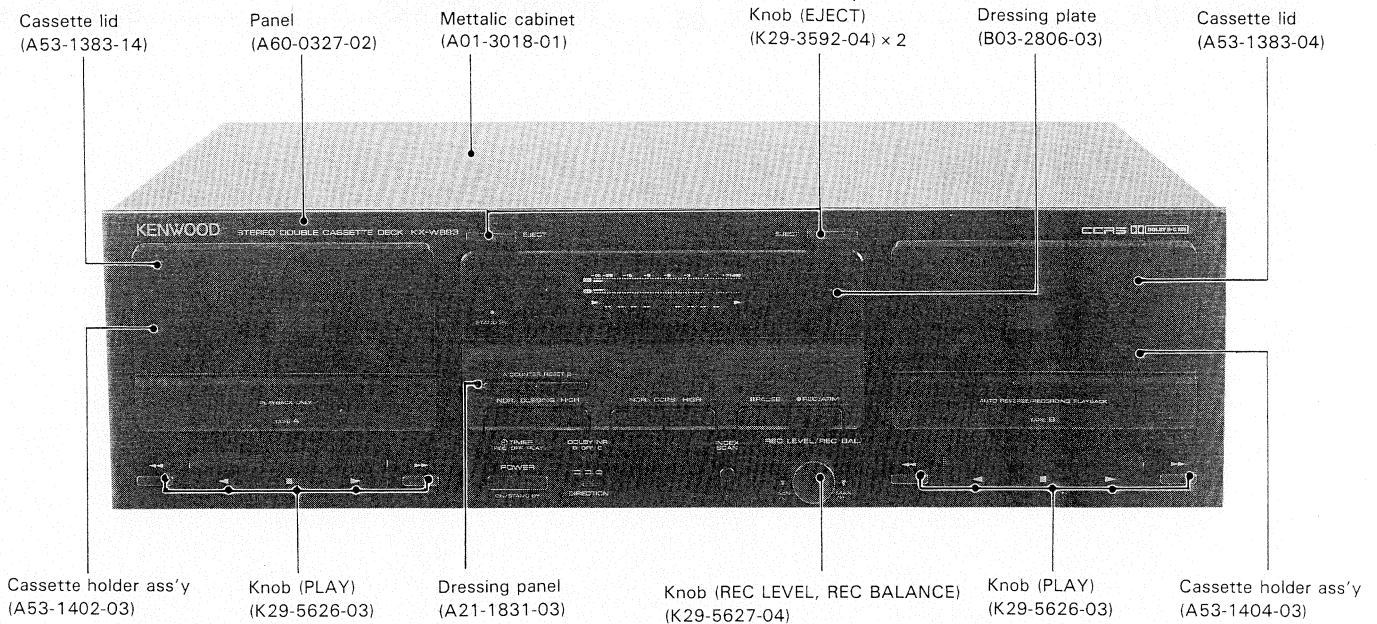



* Refer to part list on page 39.

KX-W893

CONTENTS

ACCESSORIES	2	REGLAGES	26
CONTROL AND OPERATION	3	ABGLEICH	27
DISASSEMBLY FOR REPAIR	4	WIRING DIAGRAM	29
BLOCK DIAGRAM	6	PC BOARD	31
CIRCUIT DESCRIPTION	7	SCHEMATIC DIAGRAM	33
TIMING CHART	15	EXPLODED VIEW	37
MECHANISM DESCRIPTION	18	PARTS LIST	39
ADJUSTMENT	25	SPECIFICATIONS	BACK COVER

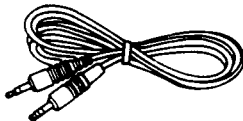
Accessories

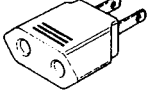
Audio cord 2 (E30-0505-05)	System control cord..... 1 (Except for U.K. and Europe) (E30-2733-05)
	
AC cord 1 (Except for some areas.) (The shape may vary depending on the destination area.)	AC plug adaptor..... 1 (Except for some areas) (E03-0115-05)
	

INSTRUCTION MANUAL

B60-1067-00	ENGLISH	
B60-1068-00	FRENCH	P
B60-1069-00	CHINESE	M
B60-1070-00	SPANISH	M

ITEM CARTON CASE

H50-0514-04

POLYSTYRENE FOAMED FIXTURE

H10-5129-12	L
H10-5130-12	R

CONTROL AND OPERATION

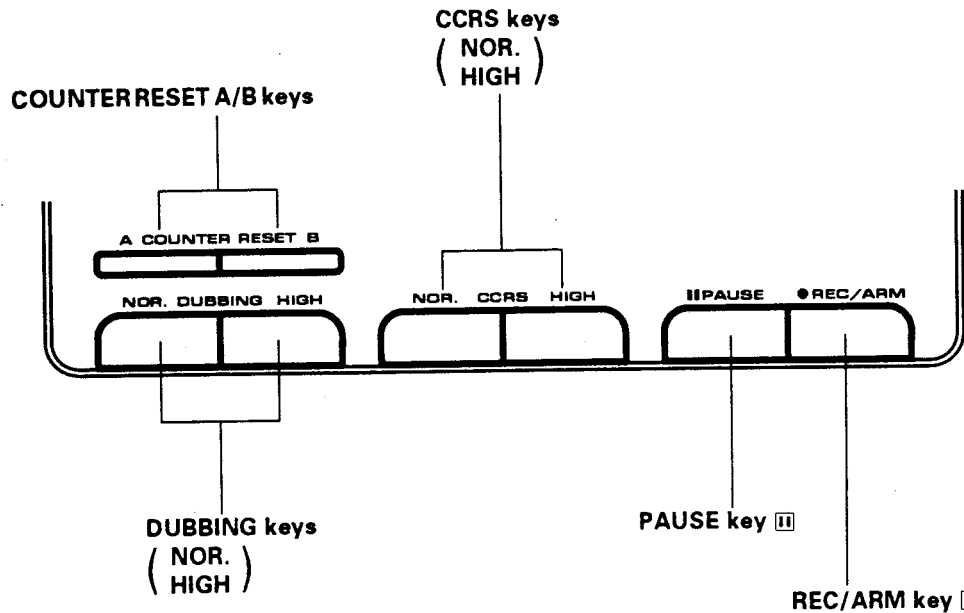
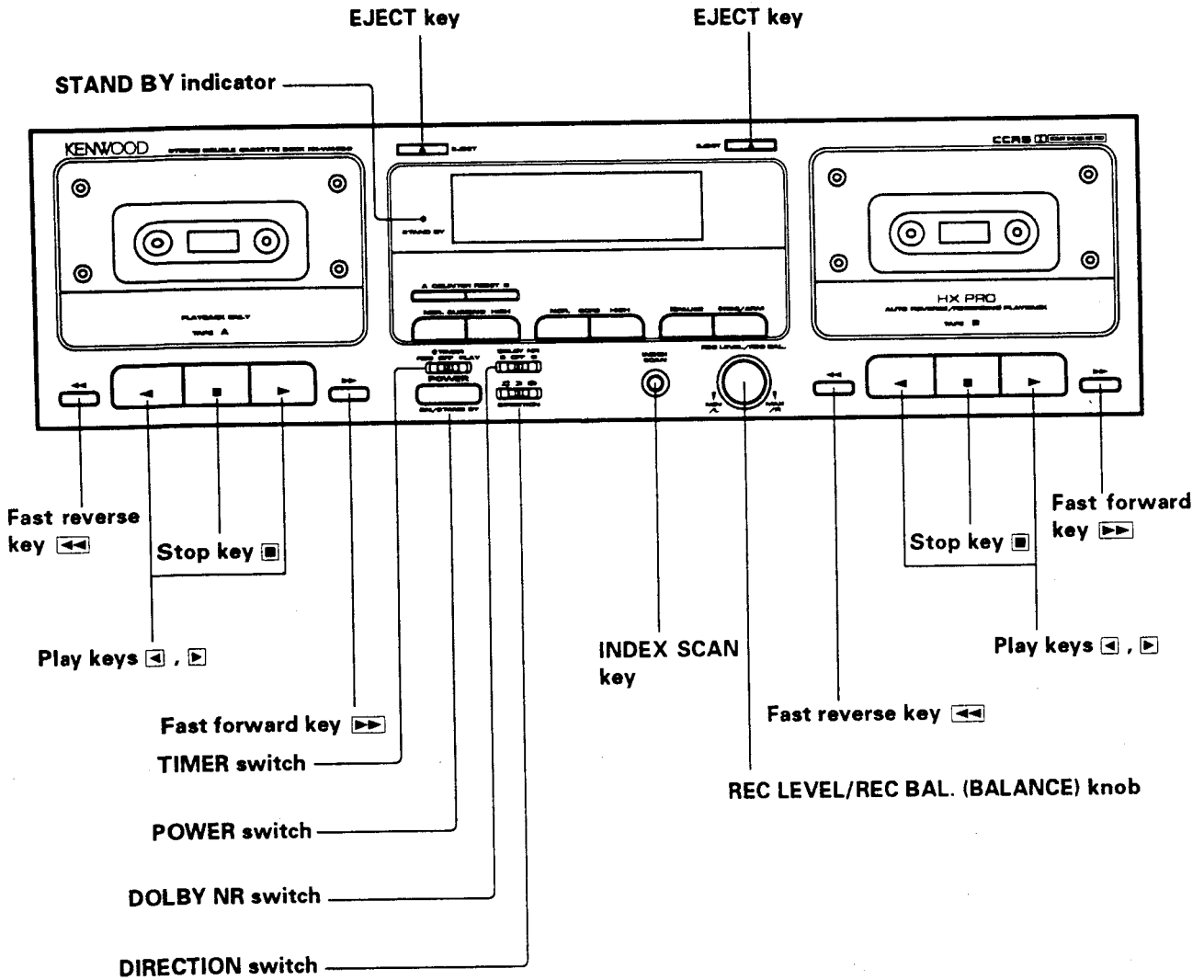

KX-W893

DISASSEMBLY FOR REPAIR

•Take out the case beforehand.

1. Push the Eject button, and when the cassette holder have opened, push the two hooks ① of the right- and left-hand sides with a square-bar standard screwdriver and the like from the outer side, and remove the lid.

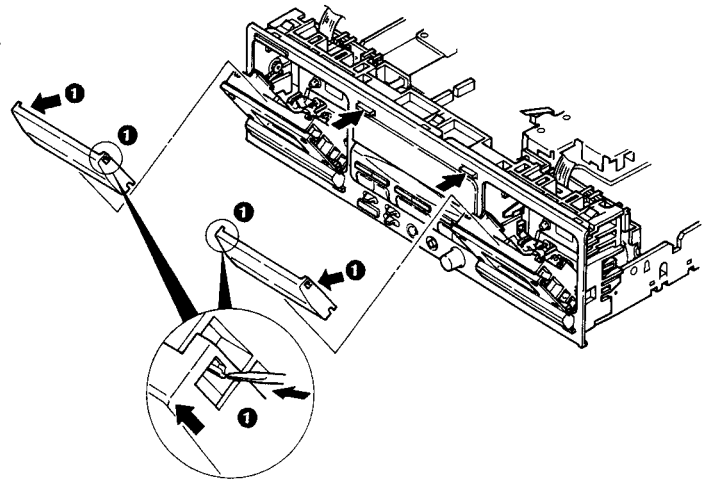

2. Remove the screw ② of the lower part, undo the 5 claws, and remove the front panel.
3. Remove the 2 screws ③ of the lower part, remove the 4 screws ④ of the rear side and remove the 4 screws ⑤ of the transformer, undo the 2 claws ⑥, and remove the sub-panel ass'y to the front side.

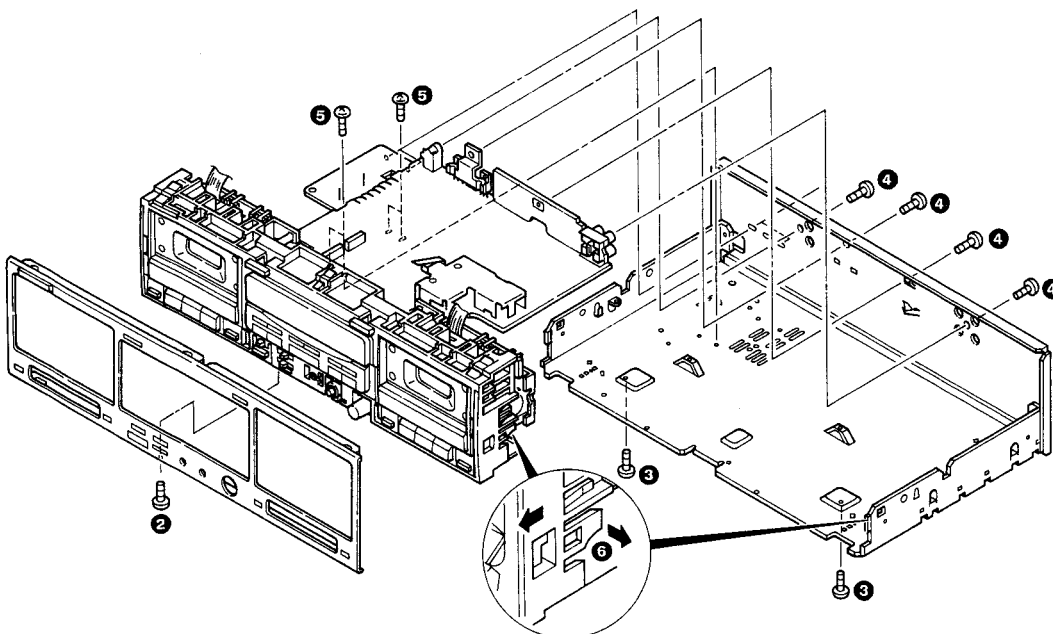

DISASSEMBLY FOR REPAIR

4. To remove the X28 (F/7) headphone jack, push the 2 claws **7** with a square-bar standard screwdriver and the like, and undo them.
5. Remove the knob **8**, undo the 6 claws, remove the 2 screws **9**, and then remove X28-(A/7), (B/7) and (C/7) (G/7).

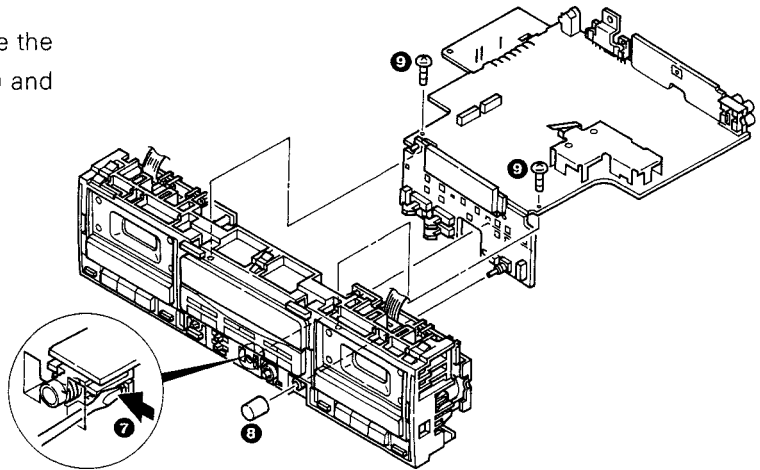

6. The mechanism ass'y comes off when the 8 screws **10** are removed.

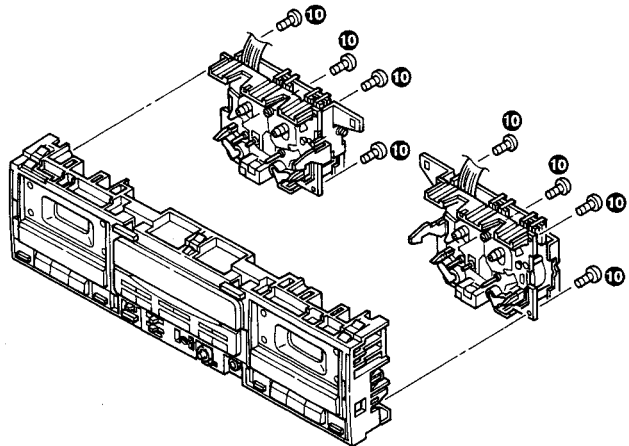

KX-W893

BLOCK DIAGRAM

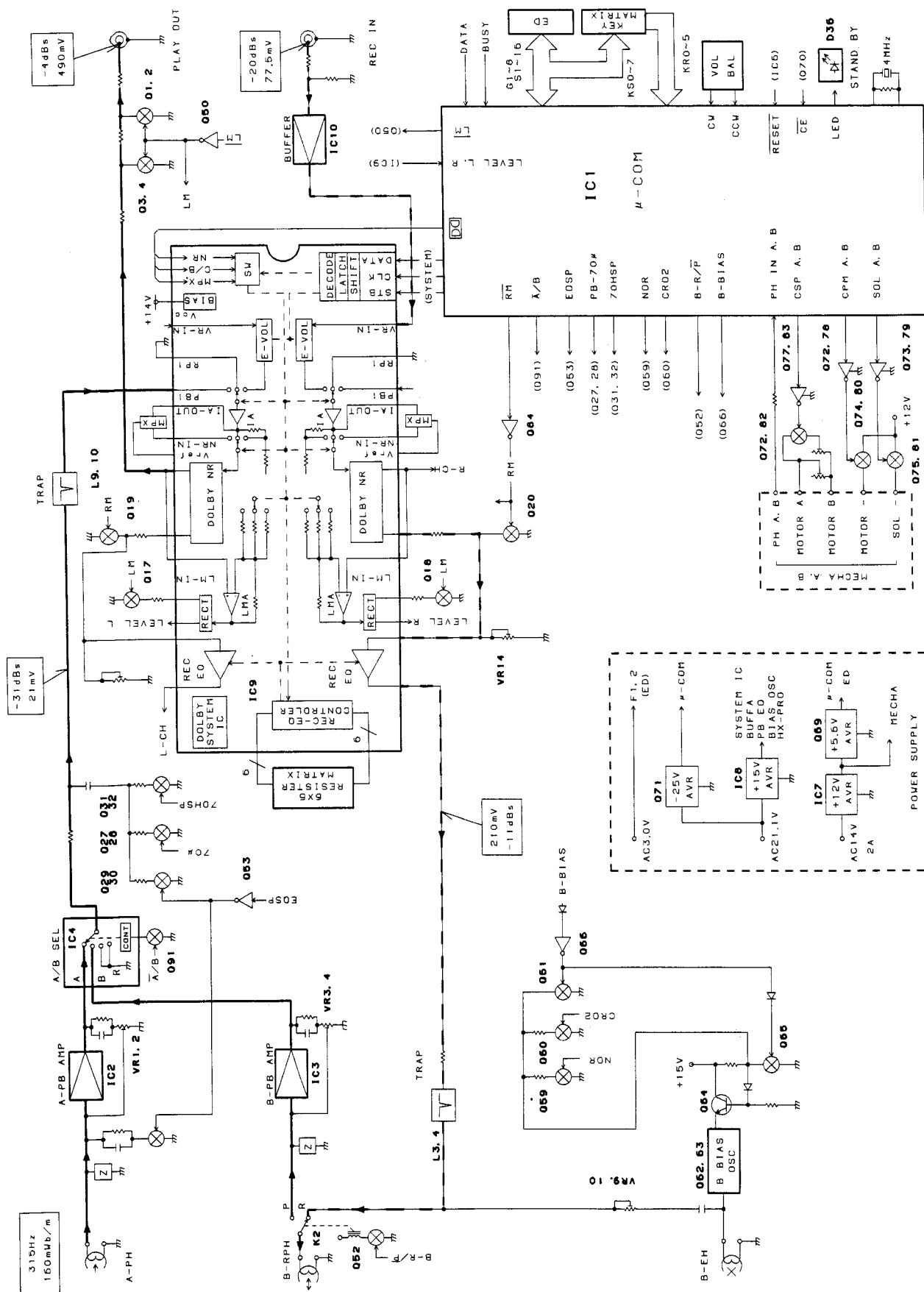

CIRCUIT DESCRIPTION

Record playback amplifier unit (X28-249X-XX)

Ref. No	Parts Name	Use/Function	Operation/Condition
IC1	CXP82324-126Q	MICRO PROCESSOR	
IC2,3	TA8125S	P-B AMP	
IC4	XRU4052B	P-B A/B SW	
IC6	PST529D	RESET IC	
IC7	XRA17812T	+ 12V AVR	
IC8	XRA17815T	+ 15V AVR	
IC9	HA1215NTA	SYSTEM IC	
IC10	NJM4565D-D or XRA15218-DX	INPUT BUFFER	
Q1 ~ 4	2SD1302 (S, T)	PLAY OUT MUTING	CONTROLLED BY Q50 ON-MUTE
Q7, 8	DTC124ES or UN4212	HIGH-SPEED EQ SW	ON-NOMAL SPEED
Q17, 18	2SC1740 (Q, R) or 2SC3311A (Q, R)	LEVEL AMP SW	CONTROLLED BY Q50 ON-MUTE
Q19, 20	2SD1302 (S, T)	REC MUTE	CONTROLLED BY Q84 ON- PLAY
Q27, 28	DTC1214ES or UN4212	PB EQ 70 μ SW	70 μ PB- ON
Q29, 30	DTC124ES or UN4212	120 μ HIGH SPEED	A- 120 μ HIGH SPEED DUB. ON
Q31, 32	DTC124ES or UN4212	70 μ HIGH SPEED	A- 70 μ HIGH SPEED DUB. ON
Q50	DTA124ES or UN4112	PB OUT MUTE DRIVER	CONTROLLED BY IC1-76 PIN
Q51	DTC124ES or UN4212	A HEAD R/P CONTROLE	CONTROLLED BY IC1- 40 PIN, A REC- ON
Q52	DTC124ES or UN4212	B HEAD R/P CONTROLE	CONTROLLED BY IC1- 44 PIN, B REC- ON
Q53	DTC124ES or UN4212	EQ SP- SW	HIGH SPEED DUB- ON
Q59	DTC124ES or UN4212	B-BIAS CONTROLE	CONTROLLED BY IC1- 43 PIN
Q60	DTC124ES or UN4212	B-BIAS CONTROLE	CONTROLLED BY IC1- 42 PIN
Q61	2SD1302 (S, T)	B-BIAS ON-OFF SW	CONTRTOLED BY Q65 B REC- OFF
Q62, 63	2SC2003 (L, K)	B-BIAS OSC	
Q64	2SC3940A (R, S)	B-BIAS CONTROLE	CONTROLLED BY Q65
Q65	UN4212	B-BIAS CONTROLE	B REC- OFF
Q66	UN4212 or DTC124ES	B-BIAS CONTROLE	B REC- ON
Q67	2SC1740S (Q, R) or 2SC3311A (Q, R)	GRID DRIVER	CONTROLLED BY IC1- 19 PIN
Q68	2SC1740S (Q, R) or 2SC3311A (Q, R)	GRID DRIVER	CONTROLLED BY IC1- 20 PIN
Q69	2SC3940A (Q, R)	+ 5.6 V AVR	
Q70	2SC1740S (Q, R) or 2SC3311A (Q, R)	RESET	CONTROLLED BY IC6
Q71	2SA1123 (R, S)	- 23 V AVR	
Q72, 78	DTC124ES or UN4212	A OR B CPM SW	
Q73, 79	DTC124ES or UN4212	A OR B SOL SW	
Q74, 80	2SA1534A (R, S)	A OR B CPM SW	
Q75, 81	2SA1534A (R, S)	A OR B SOL SW	
Q76, 82	2SA1309A (Q, R) or 2SA933S (Q, R)	A OR B CSP SW	
Q77, 83	DTC124ES	A OR B CSP SW	
Q84	DTA124ES or UN4112	REC MUTING DRIVER	CONTROLLED BY IC1- 77 PIN

KX-W893

CIRCUIT DESCRIPTION

Description of Functions

Feature

(a) Recording system

- Relay recording, W reverse (KX-W6050 only)
If decks A and B are loaded with a cassette, the direction mode is \Leftarrow or \Rightarrow , one deck is recording and the other is in the REC PAUSE mode, and the recording sources match, then, when the end of the tape on the deck recording is reached, recording continues automatically on the other deck.

Conditions:

- Decks A and B are both loaded with a cassette that can be recorded on in the appropriate current tape direction.
- The reverse mode switch is set to \Leftarrow or \Rightarrow .
- The recording source is the same for both decks.
- Neither deck is in ARM. One deck records and the other is stopped.

Operation:

1 \Leftarrow mode (A to B only)

When the end of the tape of one side is reached on the deck recording, the deck stops, and the other deck starts recording automatically.

2 \Rightarrow mode (A to B only)

When the end of the tape of the reverse side is reached on the deck recording, the deck stops, and the other deck starts recording automatically.

(b) Relay play

If decks A and B are both loaded with a cassette, and the direction mode is \Leftarrow or \Rightarrow , then when the end of the tape is reached on the deck playing, the other deck starts playing automatically.

Conditions:

- Decks A and B are both loaded with a cassette.
- The reverse mode switch is set to \Leftarrow or \Rightarrow .
- One deck plays normally, not with DPSS, and the other is stopped.

Operation

1 \Leftarrow mode

When the end of the tape is reached on the deck playing, the deck rewinds if it is playing in the forward direction, and fast forwards if it is playing in the reverse direction, and the other deck starts playing automatically in the current tape direction.

2 \Rightarrow mode

When the end of the tape of the reverse side is reached on the deck playing, the deck stops, and the other deck starts playing in the forward direction.

(c) DPSS

SKIP selection, single-tune repeat, autorecord mute, and RE-REC standby operations are performed by pressing the appropriate keys.

(d) Timer operation

Timer recording and playback are possible by setting the timer switch. When the timer switch has been set to PLAY or REC and the power is switched on, the desired operation takes places after an initial delay (about four seconds). With timer recording, "TUNER PLAY" 28H (serial code) is output about 1.5 seconds after the power comes on, and the amplifier input selector is set to TUNER.

(e) Dubbing

Normal and high-speed dubbing from deck A to deck B are possible with the NORMAL DUBBING and HIGH-DUBBING keys.

(f) CCRS

Synchronized recording is done by automatically optimizing the deck recording level to suit the CD maximum output level.

Procedure

- Load a disc in the CD player and a recordable tape in the deck.
- Set the amplifier input selector to CD, and set TAPE2 MONITOR to OFF. (For models with a REC OUT selector, set REC OUT to CD.)
- Set CD TRACK/PGM and EDIT1/2 as required.
- If you want to do relay recording, press the RELAY REC key.
- Press the CCRS/HI-CCRS key.

(g) Serial communication function

Various serial operations are possible when the deck is combined with a system having a serial communication bus.

CIRCUIT DESCRIPTION

Pin Connection

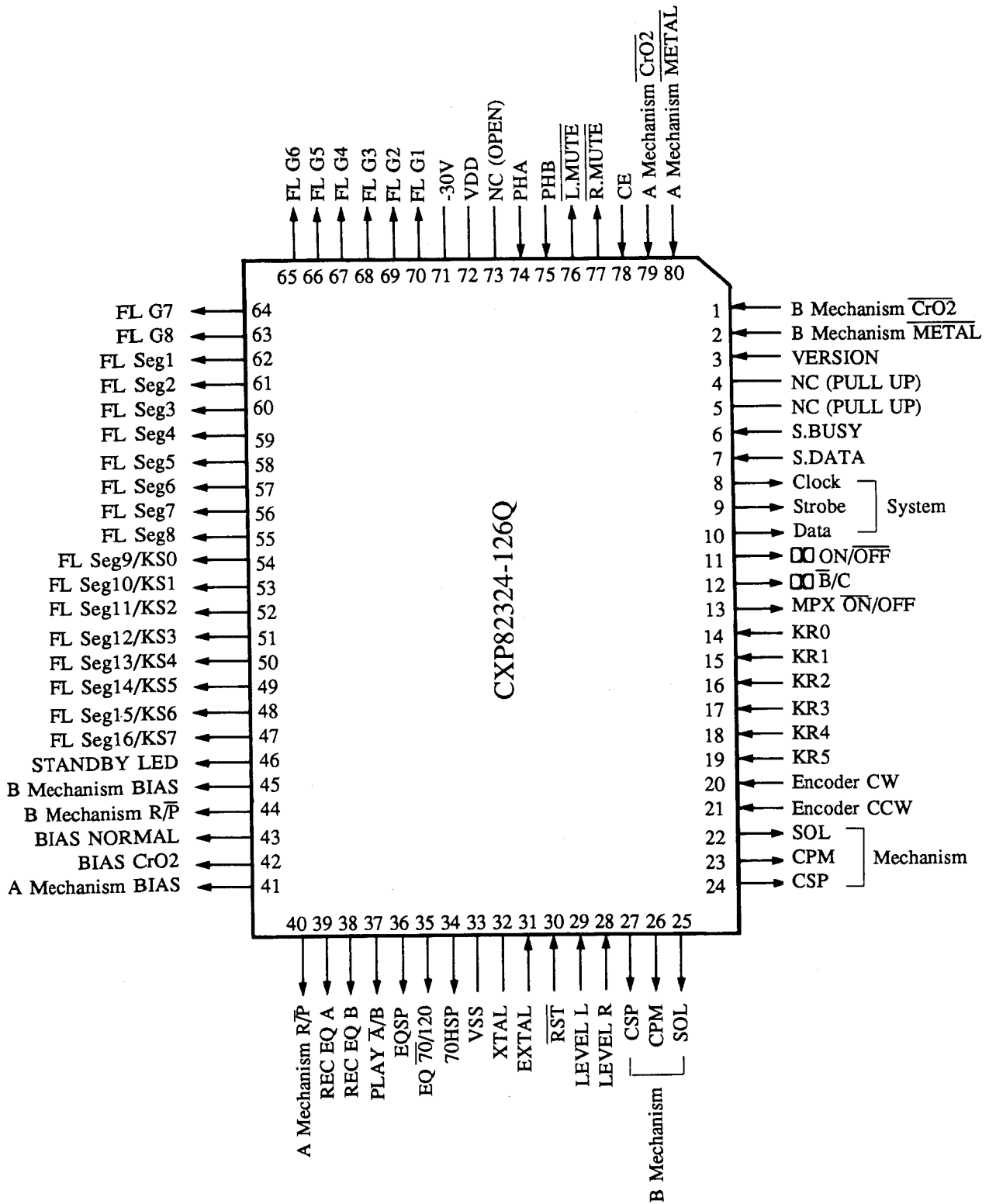

KX-W893

CIRCUIT DESCRIPTION

Pin Description

Pin No.	I/O	Name	Description
1	I	B Mechanism $\overline{\text{CrO2}}$	B-mechanism CrO2 tape detection H: NORMAL
2	I	B Mechanism $\overline{\text{METAL}}$	B-mechanism metal tape detection L: METAL
3	I	VERSION	Destination changeover H: 6050, L: 4050, W893
4			Unused (PULL UP)
5			Unused (PULL UP)
6	I/O	S. BUSY	Serial BUSY input/output
7	I/O	S. DATA	Serial data input/output
8	O	CLK	System IC clock output
9	O	STB	System IC strobe signal input
10	O	DATA	System IC serial data output
11	O	$\overline{\text{ON}}$ ON/OFF	Dolby ON/OFF control H: ON
12	O	$\overline{\text{B/C}}$ B/C	Dolby B/C switching H: C
13	O	$\overline{\text{ON}}$ MPX ON/OFF	MPX filter switching L: ON
14 ~ 19	I	KR0 ~ KR5	Key return signal input H: RETURN
20	I	Encoder CW	Encoder clock signal input H: RETURN
21	I	Encoder CCW	Encoder clock signal input H: RETURN
22	O	SOLA	A-solenoid control H: ON
23	O	CPMA	A-capstan motor control H: ON
24	O	CSPA	A-capstan motor switching H: NORMAL L: HIGH SPEED
25	O	SOLB	B-solenoid control H: ON
26	O	CPMB	B-capstan motor control H: ON
27	O	CSPB	B-capstan motor switching H: NORMAL L: HIGH SPEED
28	I	LEVEL R	CCRS, DPSS Rch signal input
29	I	LEVEL L	CCRS, DPSS Lch signal input
30		$\overline{\text{RESET}}$	Reset signal input L: RESET
31 ~ 32	I	EXTAL, XTAL	Clock oscillator connection terminal (10 MHz)
33		Vss	GND

CIRCUIT DESCRIPTION

Pin No.	I/O	Name	Description	
34	O	70HSP	EQ SP HIGH & BIAS 70 μ s	H: ON
35	O	120/70	Bias switching	H: 120 μ s
36	O	EQ SPEED	PLAY EQ SPEED switching	H: NORMAL
37	O	PLAY \bar{A}/\bar{B}	A/B head switching	H: B head ON
38	O	REC EQ B	REC equalizer A/B switching	
39	O	REC EQ A	REC equalizer A/B switching	
40	O	A Mechanism R/ \bar{P}	A REC/PLAY switching	H: REC
41	O	A Mechanism BIAS	A bias ON/OFF control	H: ON
42	O	BIAS CrO2	PLAY BIAS SWITCHING	H: CrO2
43	O	BIAS NOR	PLAY BIAS SWITCHING	H: CrO2
44	O	B Mechanism R/ \bar{P}	B REC/PLAY switching	H: REC
45	O	B Mechanism BIAS	B bias ON/OFF control	H: ON
46	O	STBY LED	Standby LED ON	H: ON
47~54	O	KS7~KS0 & Seg 16~9	Key scan signal output & FL tube segment signal output	H: SCAN H: ON
55~62	O	Seg 8~1	FL tube segment signal output	H: ON
63~70	O	Grid8~1	FL tube grid signal output	H: ON
71		VFDP	FL tube driving voltage (-30 V)	H: ON
72		VDD	Positive power supply terminal (+5V)	
73			Unused (OPEN)	
74	I	PHA	A-mechanism rotation detection input	
75	I	PHB	B-mechanism rotation detection input	
76	O	\bar{L} MUTE	Line mute control	L: ON
77	O	\bar{R} MUTE	Rec mute control	L: ON
78	I	\bar{CE}	Backup detection terminal	L: BACK UP
79	I	A Mechanism $\bar{CrO2}$	A-mechanism CrO2 tape detection	H: NORMAL
80	I	A Mechanism \bar{METAL}	A-mechanism metal tape detection	L: METAL

KX-W893

CIRCUIT DESCRIPTION

Test Mode

The system enters this test mode when KS4 (TP4) and KR5 (TP3) are shorted together with a diode and the AC power plug connect to the AC outlet.

Cancel method : Press the REC pause key or disconnect the AC power plug from the AC outlet.

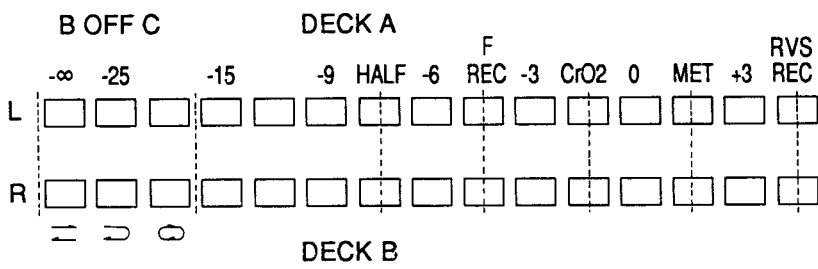
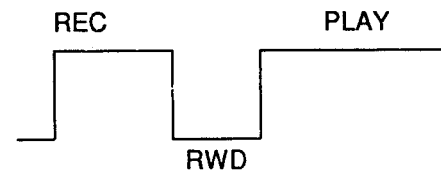
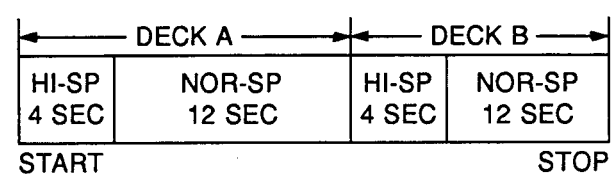
Mode No	Timer switch position	Key	Operation
1	-	-	<p>ALL ON-DISPLAY All the indicators light for about 1.5 sec. Keys are enabled after the indicators go out.</p>
2	-	-	<p>MECHANICAL SWITCH DISPLAY The state of each mechanical switch is shown on the level meter.</p>  <p style="text-align: center;">DECK B</p>
3	OFF	REC	<p>4 SECOONDS RECORDING Record for 4 seconds, returns to the begining, and play back (can be repeated).</p> 
4	PLAY	POWER	<p>AUTOMATIC TIMER PLAY Set timer play when the power is switched on.</p> 

CIRCUIT DESCRIPTION

Mode No	Timer switch position	Key	Operation			
5	REC	POWER	<p>AUTOMATIC TIMER RECORDING Set timer recording when the power is switched on. (Deck B only)</p> <table border="1" style="margin-left: auto; margin-right: auto;"> <tr> <td style="text-align: center;">REC 15 SEC</td> <td style="text-align: center;">RWD</td> <td style="text-align: center;">PLAY</td> </tr> </table> <p>START</p>	REC 15 SEC	RWD	PLAY
REC 15 SEC	RWD	PLAY				
6	OFF	★	<p>PLAY BACK SPEED SWITCHING</p> <p>FWD Key : Normal speed P.B (FWD) FF Key : Hi-speed P.B (FWD) RVS Key : Normal speed P.B (RVS) RWD Key : Rewind</p>			
7	OFF	H.DUBB N.DUBB	<p>DUBBING MODE The dubbing mode is entered pressing. Then dubbing key for both high and normal. If the dubbing key is pressed after that, only the speed and circuit system changed.</p>			

KX-W893

CIRCUIT DESCRIPTION

TIMING CHART

STOP to FWD REC

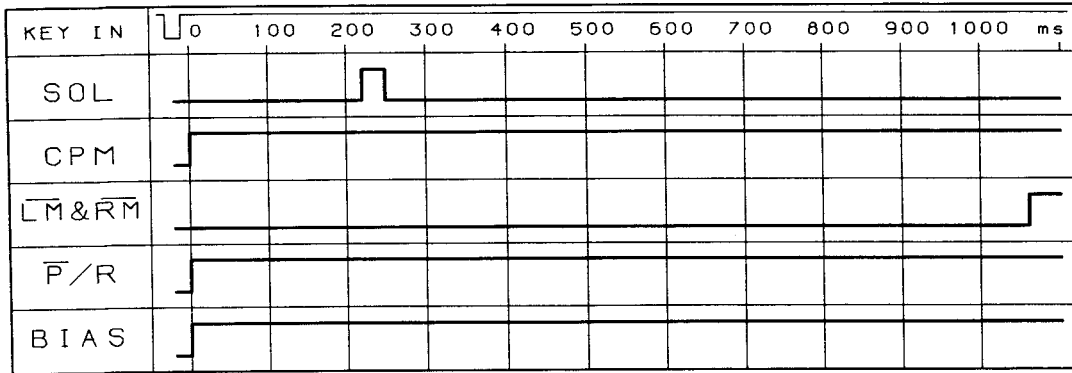

STOP to RVS REC

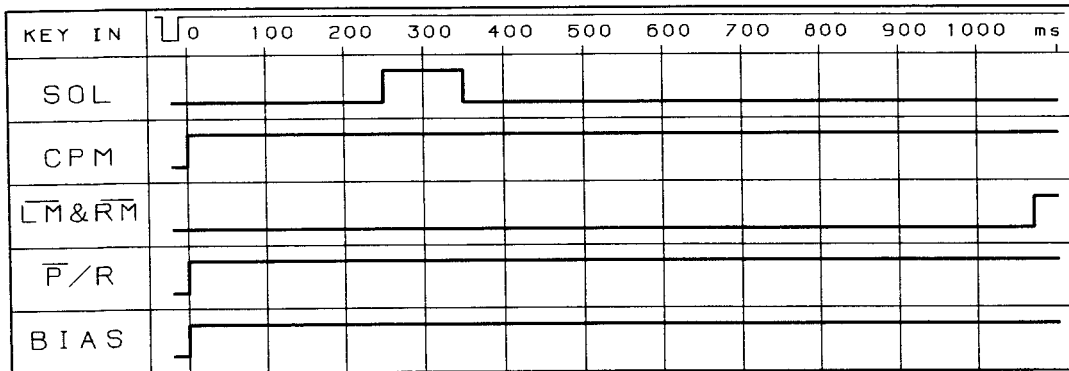

FWD REC to STOP

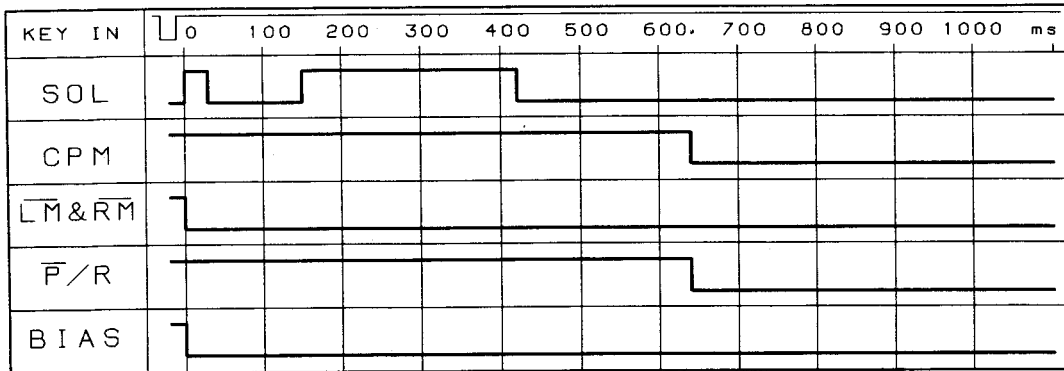

RVS REC to STOP

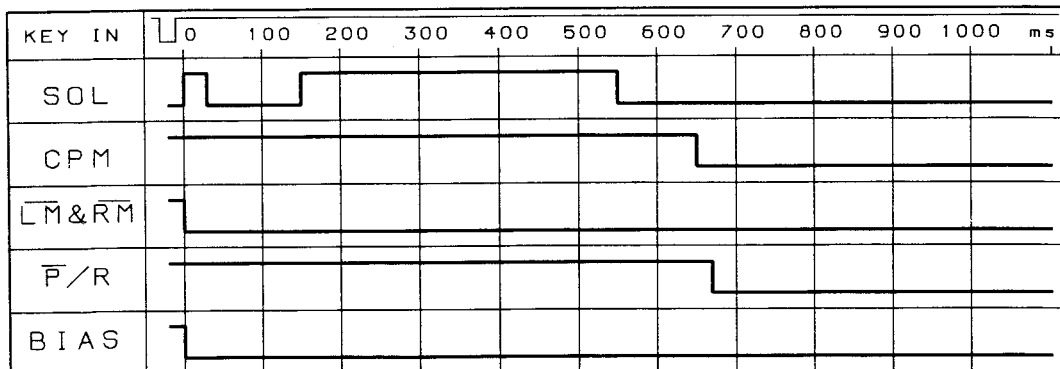

CIRCUIT DESCRIPTION

STOP to FF

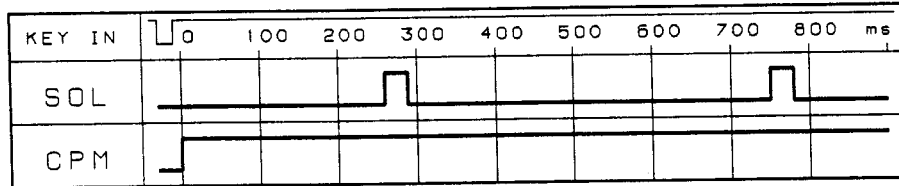

STOP to RWD

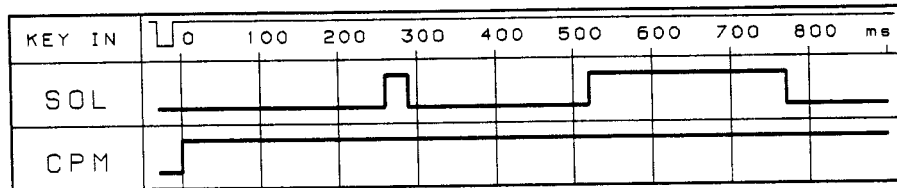

FF/RWD to STOP

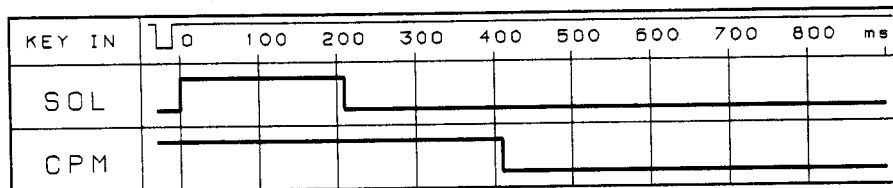

KX-W893

CIRCUIT DESCRIPTION

FWD PLAY to CUE

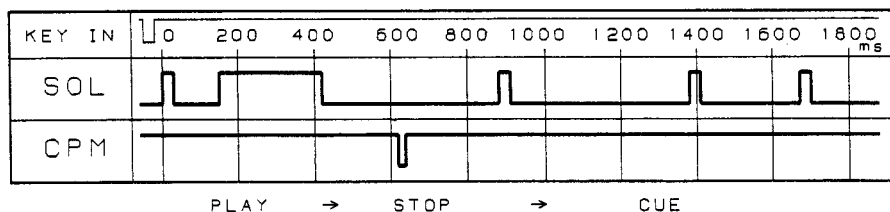

FWD PLAY to RVW

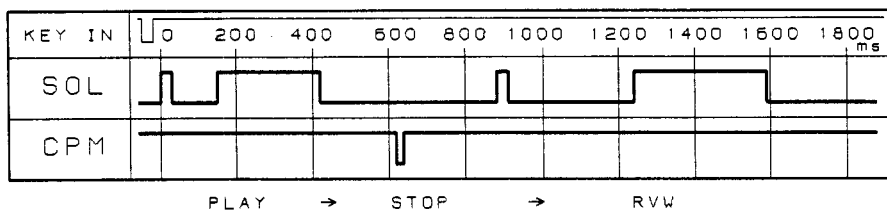

RVS PLAY to CUE

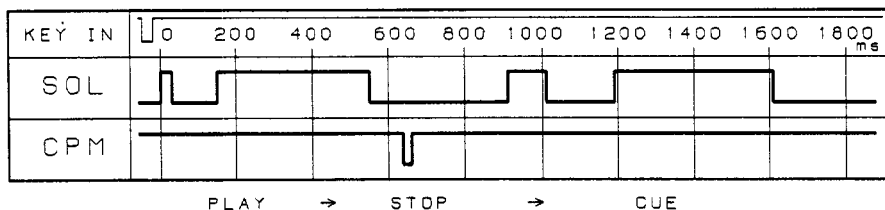

RVS PLAY to RVW

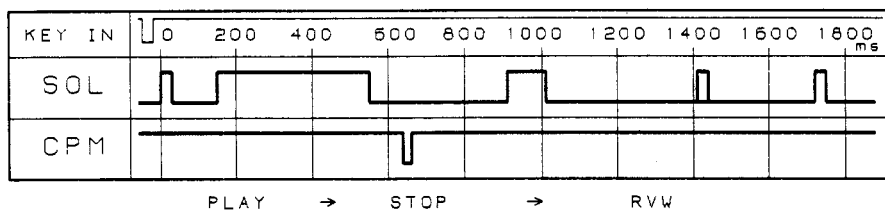

KX-W893

MECHANISM DESCRIPTION

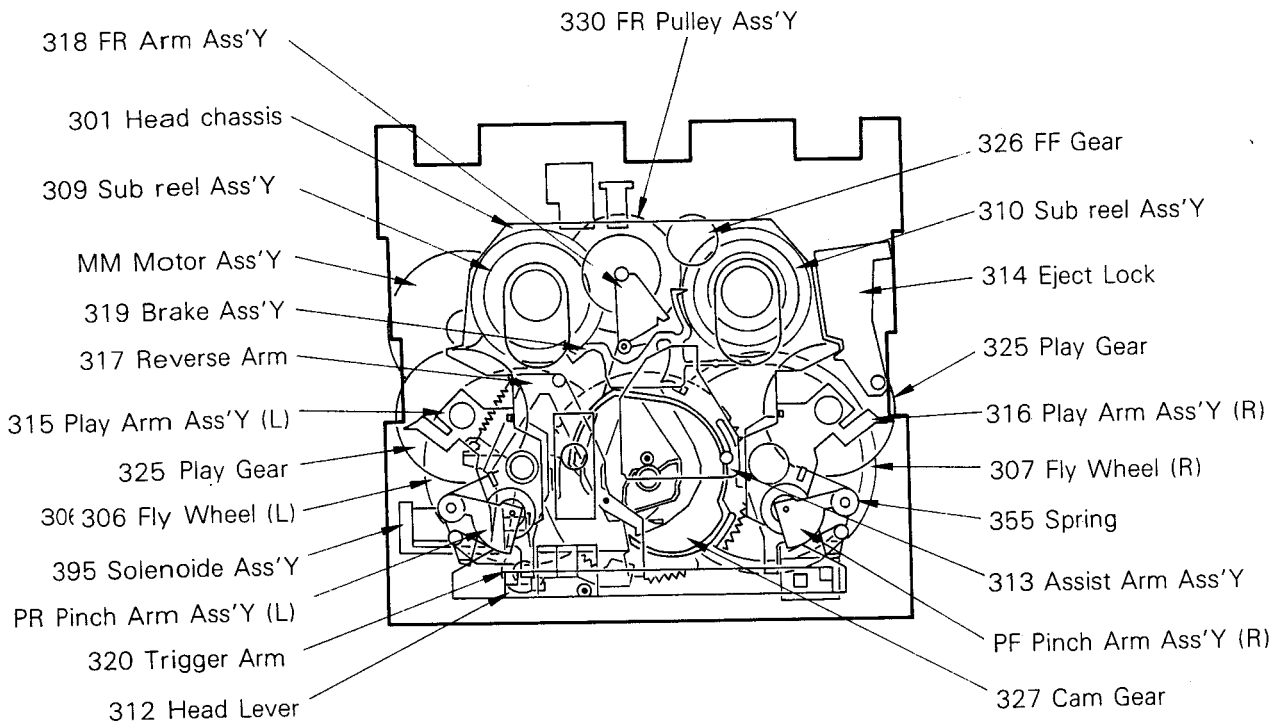

Take-up Torque:	35~70 g · cm
FF. REW Torque:	80~170 g · cm
Back Tension Torque:	2~6 g · cm

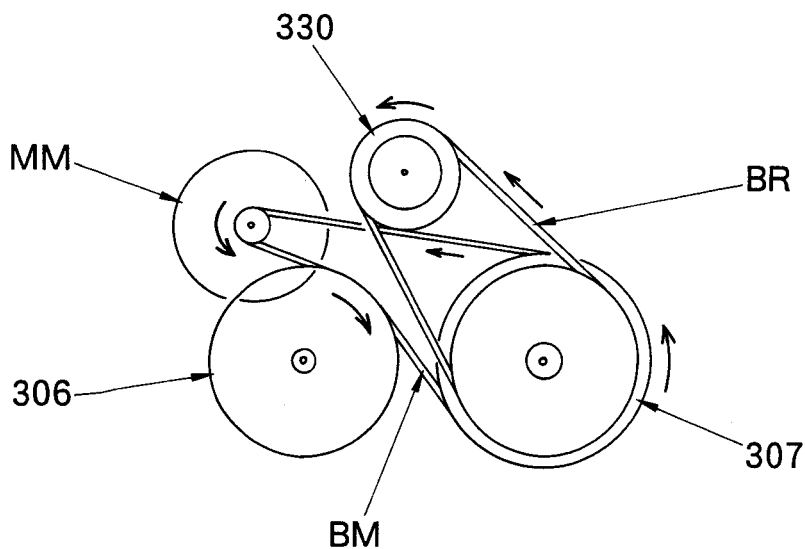

KX-W893

MECHANISM DESCRIPTION

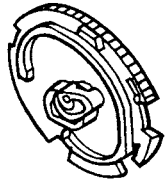

Cam gear

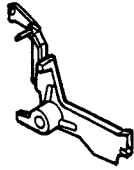

Trigger arm



Reverse arm



FR arm Ass'y



FR Pulley Ass'y

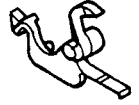

Brake arm

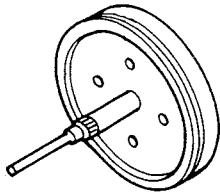

Fly Wheel (L)

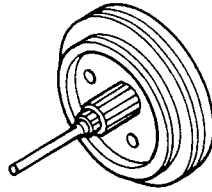

Fly Wheel (R)



Reel cap



Eject lock



FF gear



Subreel Ass'y (R)



Subreel Ass'y (L)

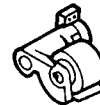

Pinch arm Ass'y (L)

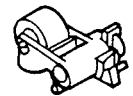

Pinch arm Ass'y (R)

Play gear

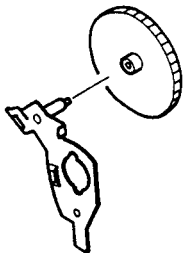

Play arm Ass'y (L)

Play gear

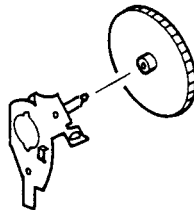

Play arm Ass'y (R)

Assist arm Ass'y

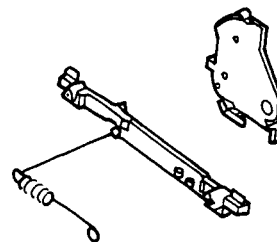

Head lever

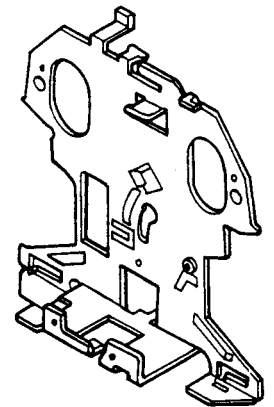

Head chassis

MECHANISM DESCRIPTION

FWD PLAY/REC

- ① The plunger turns ON for 30 ms, and turns OFF immediately.
- ② The boss (A) on the trigger arm comes off the stopper, and the cam gear begins to rotate.

- ③ The boss (B) on the rear arm passes through the inner side of _____ on the cam gear.

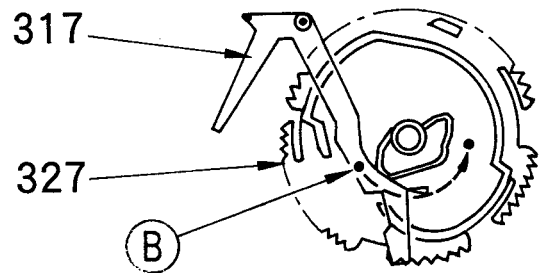
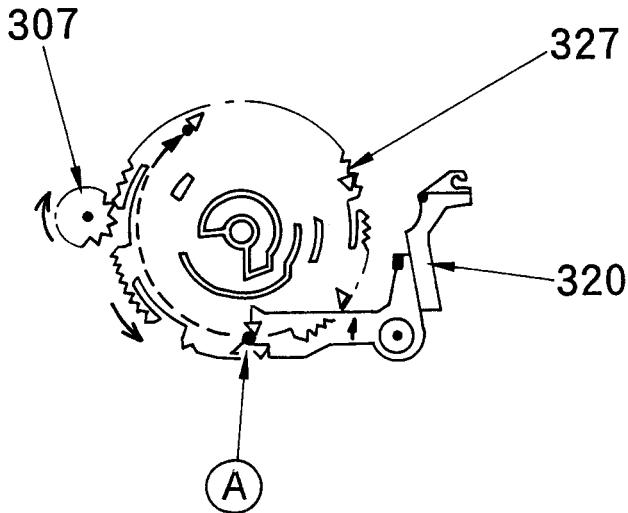

- ④ The cam of the cam gear pushes the boss (C) on the assist arm ASS'Y up, and the rotation of the cam gear is stopped by the boss (A) on the trigger arm and gets at the FWD PLAY/REC position.

- ⑤ Since the assist arm ASS'Y is fixed on the head chassis, the head chassis also rises up to the FWD PLAY/REC position.

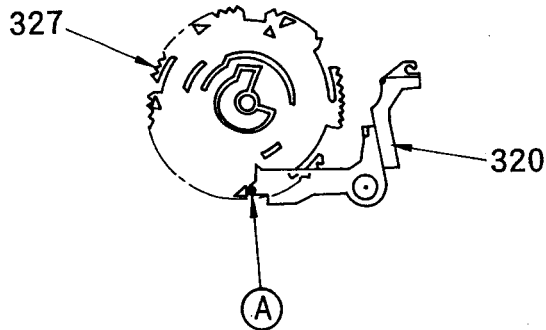

- ⑥ The pinch roller (R) at the FWD side is also pushed up by the boss (D) of the head lever on the head chassis, and touches the capstan.

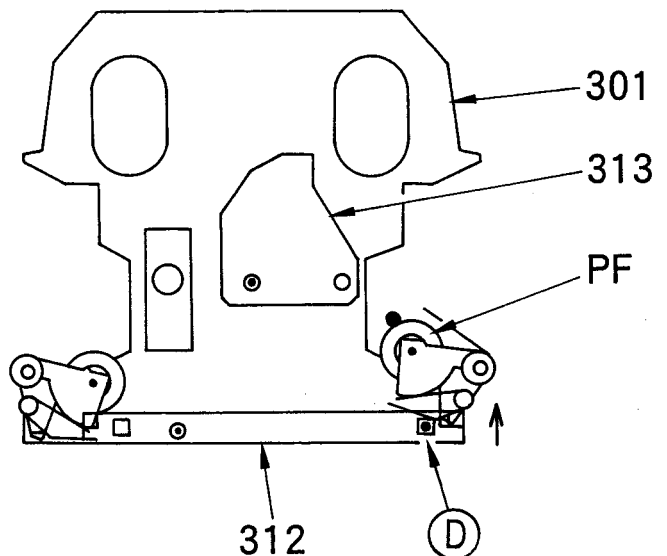
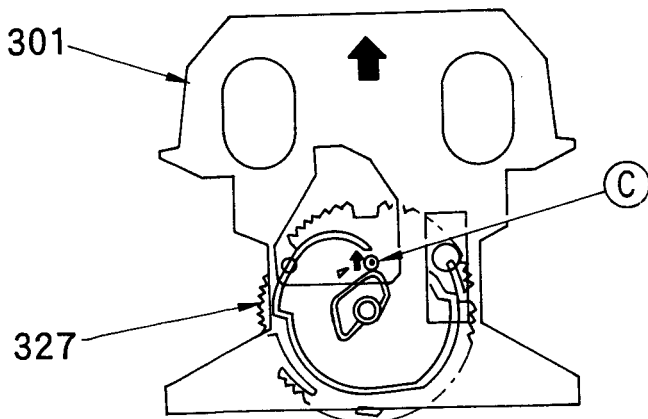

KX-W893

MECHANISM DESCRIPTION

- ⑦ Since the play arm ASS'Y (R) becomes free as a result of the rise of the head chassis, it is rotated in the arrow direction (E) by the spring (E), and the play gear is engaged with the gear of the sub-reel ASS'Y (R), thereby transmitting the rotation of the flywheel R to the reel (R).

The play arm ASS'Y of the L-side also becomes free from the head chassis, but it does not rotate because it is in contact with the boss (G) of the head lever.

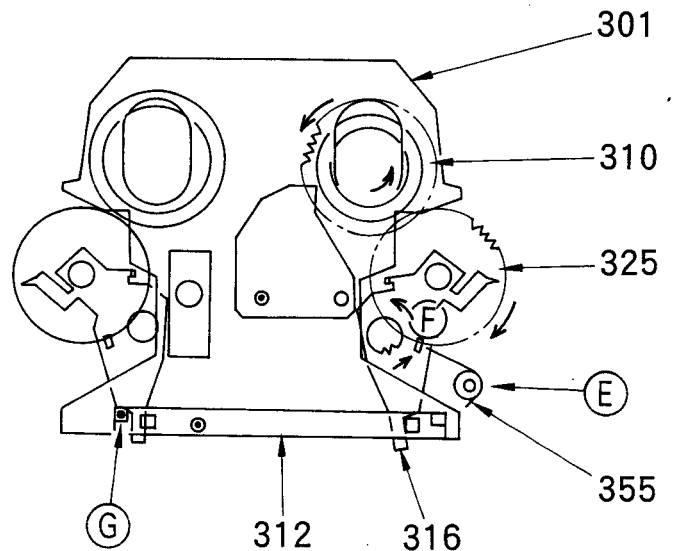

RVS PLAY/REC

- ① The plunger turns ON for 100 ms.
 ② The boss on the trigger arm comes off, and the cam gear begins to rotate.
 Since the trigger arm is pulled by the plunger for 100 ms, the boss (B) on the reverse arm passes through the outer side of the cam on the cam gear.

- ③ Since the reverse arm also moves concurrently with the rotation of the cam gear and pushes the boss (H) on the head bar, the head rotates.

(Schematics of the head rotation)

- ④ The head chassis rises in the same way as in the forward play, and is fixed at the RVS PLAY/REC position.

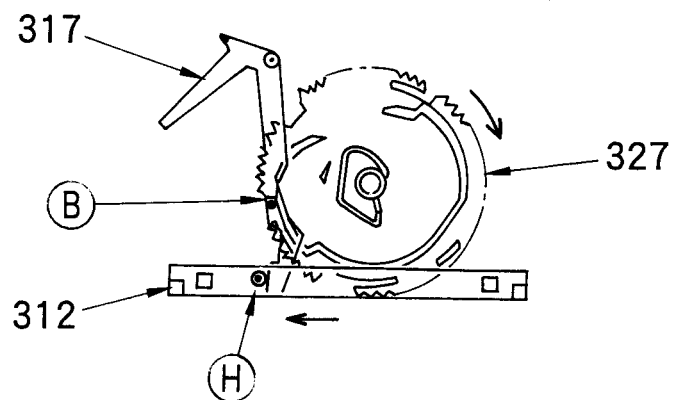
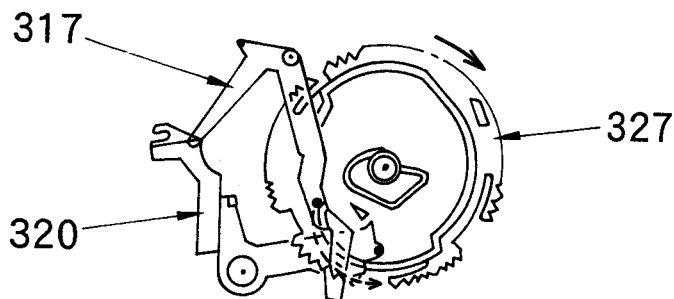

MECHANISM DESCRIPTION

- ⑤ When the head lever moves, the pinch roller (L) is pushed up.

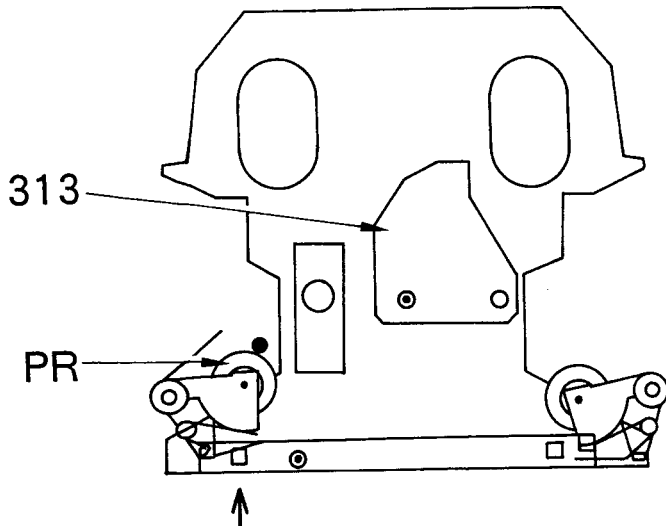

- ⑥ The play gear is engaged with the gear of the sub-reel ASS'Y and the rotation of the flywheel (L) is transmitted to the reel (L).

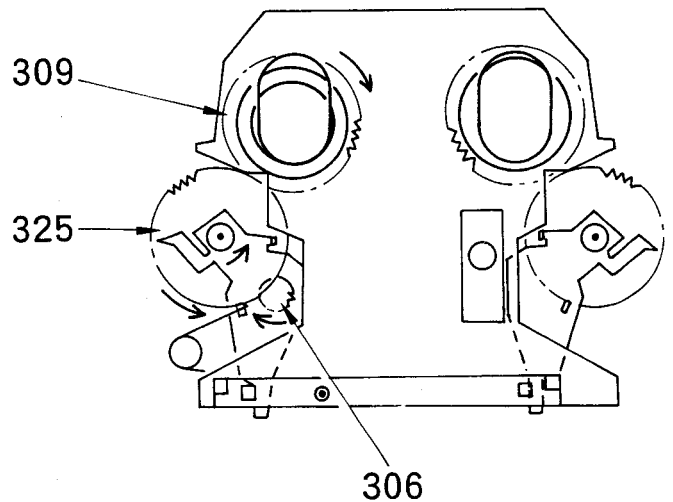

FF

- ① The plunger turns ON for 30ms.
- ② The cam gear begins to rotate.
- ③ The FR arm ASS'Y is pulled to the arrow direction by the belt of the FR pulley ASS'Y. As a result, the boss ① on the FR arm ASS'Y passes through the innermost circumference trajectory on the cam gear.

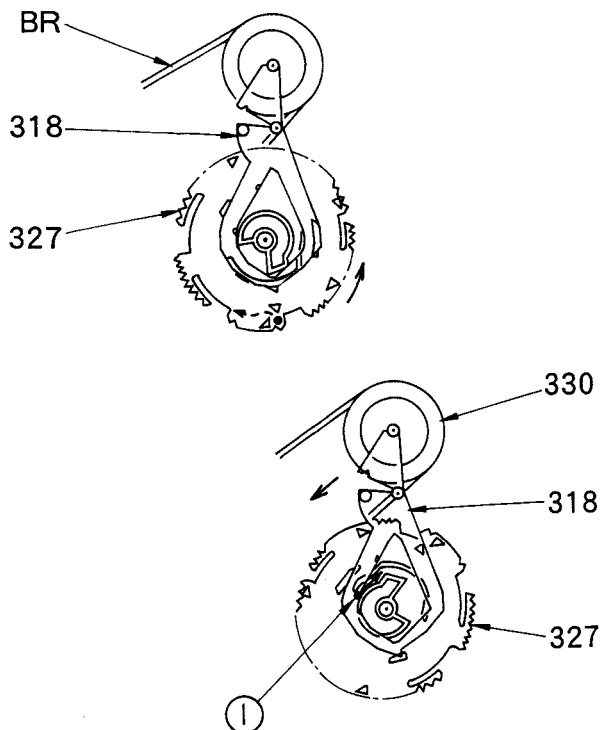

- ④ After 420 ms the plunger is turned ON once again for 30 ms and passes over the stopper, the cam gear continues to rotate, and is held at the next stopper position.

At that time the FR arm ASS'Y also moves in the arrow direction (J), the gear of the FR pulley ASS'Y and the gear of the sub-reel ASS'Y (R) are engaged with the FF gear, the reel (R) is rotated, and as a result the mechanism gets in the FF mode.

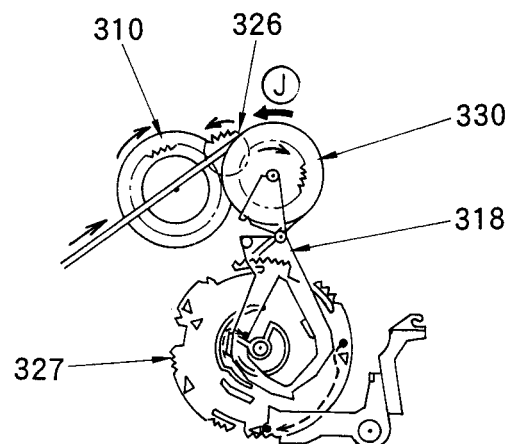

KX-W893

MECHANISM DESCRIPTION

RWD

1. The plunger turns ON for 30 ms, and the cam gear begins to rotate.
2. After 250 ms the plunger turns ON once again for 250 ms, but since the FR arm ASS'Y is tilted to the arrow direction by the boss (K) at that time, the FR arm ASS'Y is held by the projection (L) of the trigger arm, it is further tilted to the sub-reel ASS'Y (L) direction by the boss (M), and the reel (L) rotates, thereby switching the operation of the mechanism to the RWD mode.

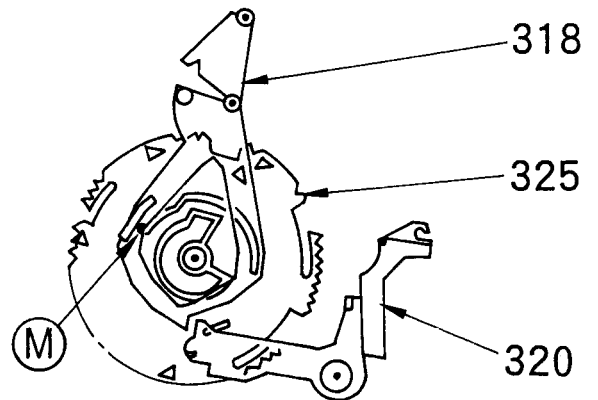
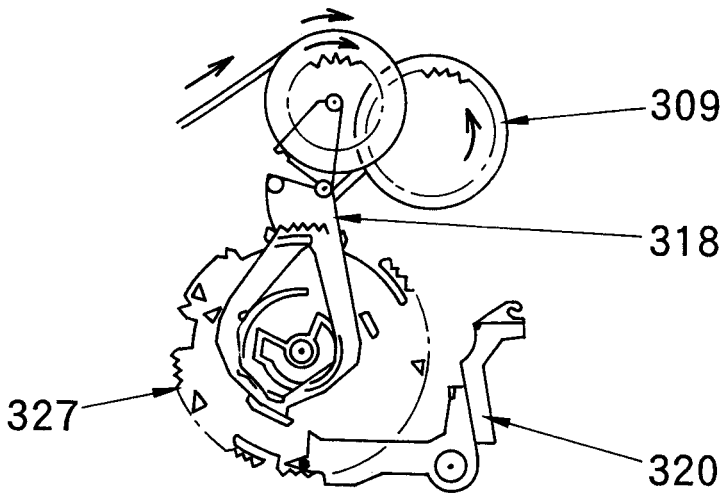
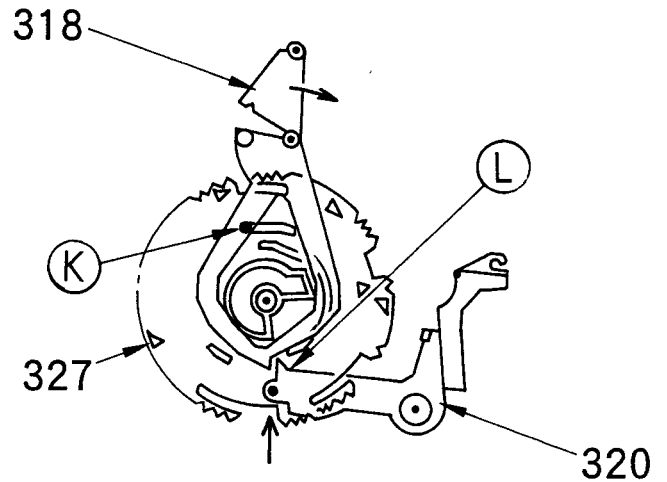

FF/RWD

The head chassis is also raised by the cam of the cam gear, but it is held at a position where the pinch roller does not touch the capstan and the play gear does not touch the reel ASS'Y.

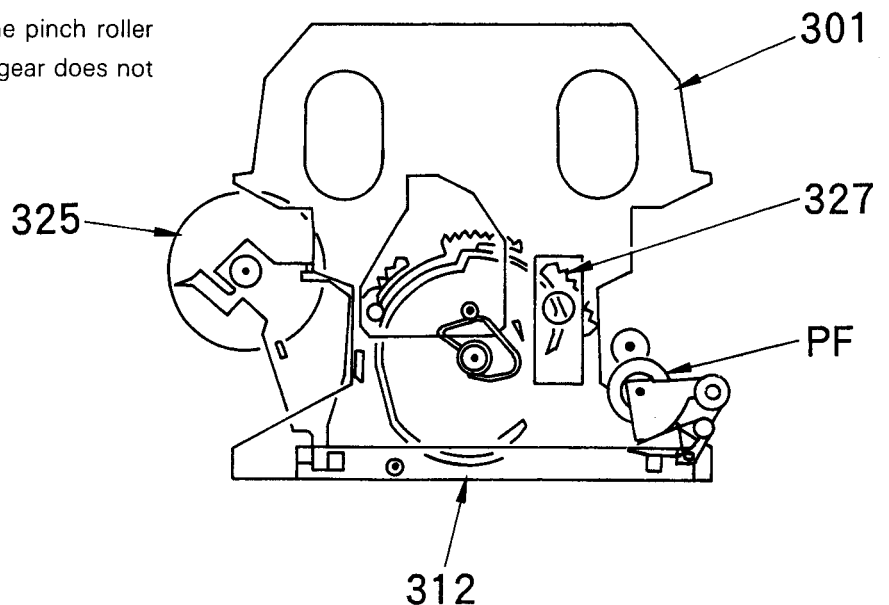

MECHANISM DESCRIPTION

PLAY/REC → STOP

- ① The plunger turns ON for 30 ms.
- ② After 120 ms the plunger turns ON once again and is kept ON for 270 ms in the FWD mode and for 400 ms in the RVS mode, and the cam gear rotates up to the STOP position.

FF/RWD → STOP

- ① The plunger turns ON for 210 ms, and the cam gear rotates up to the STOP position.

BRAKE

- ① Since the brake arm is rotated in the arrow direction by the boss (N) on the cam gear, the gear of the reel ASS'Ys (L) and (R) are stopped for approximately 40 ms immediately before the STOP position.

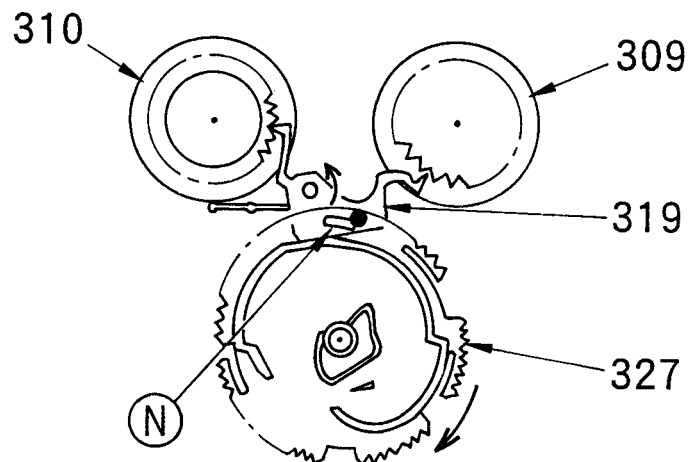

CUE/REVIEW

The cam gear mechanism is returned once from the PLAY state to the STOP position, and then it is carried once again to the CUE/REVIEW position by the plunger.

KX-W893

MECHANISM DESCRIPTION

POSITION OF THE CAM GEAR IN THE VARIOUS MODES.

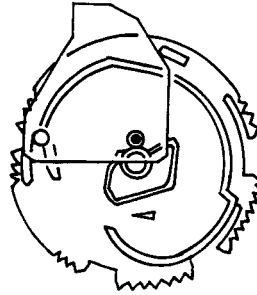
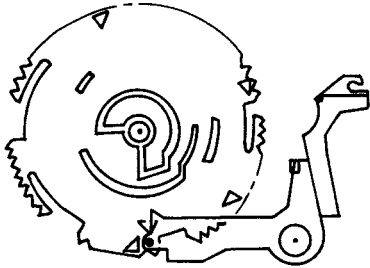

STOP

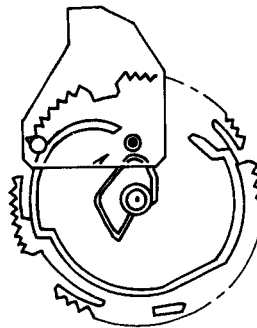
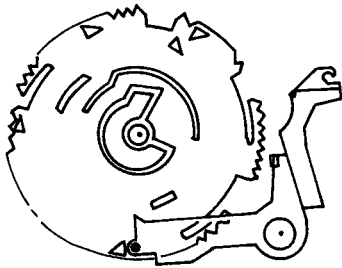

PLAY/REC

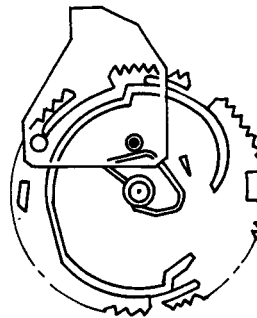
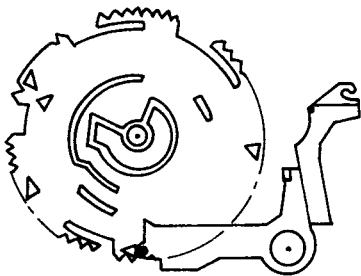

FF/RWD

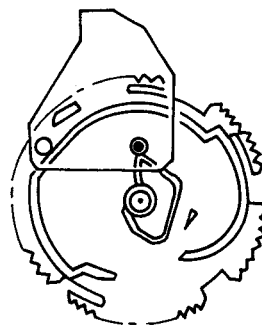
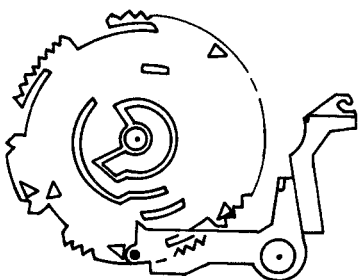

CUE/REVIEW

ADJUSTMENT

Order	Item	Input setting	Output setting	Deck settin	Adjustment points	Adjustment method	Fig.
Unless otherwise specified, set the respective switches as follosw: TAPE: NORMAL DOLBY: OFF INPUT: LINE							
I. Cassette mechanism section (Recording/play head adjustment)							
(1)	Degaussing and cleaning	—	—	Power: off, Degaussing, cleaning, PLAY	Recording heads, Erase heads, Capstans, Pinch rollers	Degauss the recording/play heads by a head eraser. Clean the recording/play heads, erase heads capstans and pinch rollers by a cotton swab soaked with alcohol.	
(2)	Recording/play head azimuth	SCC-1727, TCC-153, MTT-114, 10 kHz, -10 dBs	(B)	PLAY	Azimuth adjustment screw	Maximize the output and adjust so that the Lissajous figure nears a line slanted 45°	(a)
II. Printed circuit board adjustment Note: First perform the double-speed adjustment.							
(1)	Tape speed (double)	SCC1727 TCC-110 MTT-114 3 kHz	(B)	TEST MODE 4 → 3 short AC PLUG CONNECT TO AC OUTLET	A DECK: VR51 B DECK: VR53	Adjust so that the frequency is 6 kHz at the tape center.	
(2)	Tape speed (normal)	SCC1727 TCC-110 MTT-111 3 kHz	(B)	FF KEY HI-SPEED F. PLAY NOR SPEED KEY	A DECK: VR50 B DECK: VR52	Adjust so ;that the frequency is 3 kHz at the tape center.	
III. Printed circuit board adjustment							
(1)	Playback level	MTT-150 400 Hz	(B)	PLAY	A DECK: VR1 (L) VR2 (R) B DECK: VR3 (L) VR4 (R)	Adjust that the playback output is -1 dBs	
		MTT-256, SCC1727 315 Hz (160 mWb/m)				Adjust that the playback output is -4 dBs	
		MTT-256U, TCC-160 315 Hz (250 mWb/m)				Adjust that the playback output is -0 dBs	
(2)	Bias current	1 kHz -20 dBs	(B)	Adjust electronic volume so that the recording monitor output becomes -20 dBs at 1 kHz, and record and play 1 kHz adn 10 kHz alternately.	B DECK:(L) VR9 VR10	Record 1 kHz and 10 kHz reciprocally, and adjust so that they are identical in pplayback level.	
(3)	RECORD LEVLE	1 kHz -10 dBs	(B)	1 kHz -10 dBs	B DECK (L): VR13 (R): VR14	Adjust the rairable resistor so that t playing level at -10 dBs is obtained.	
(4)	BIAS OSCILATING FREQUENCY	Load the non recorded tapes on Deck A and B.		Connect the frequency counter between E. H & GND on Deck A, between E. H & GND on Deck B.	DECK B: L21	Adjust so that the frequency counter shows 105 kHz.	
(5)	BIAS LEAK	Load a the non	(B)	Load a metal tape. and dub in a high speed mode.	L9 (L) L10 (R)	Minimum (Point)	

REGLAGE

Ordre	Sujet	Réglage d'entrée	Réglage de sortie	Réglage de platine	Points d'ajustement	Méthode d'ajustement	Figure
A moins, de spécification contraire, régler les commutateurs respectils comme suit: TAPE: NORMAL DOLBY: OFF INPUT: LINE I. Section de mécanisme de cassette (ajustement de tête d'enregistrement/lecture)							
(1)	Démagnétisation et nettoyage	—	—	Alimentation coupée, démagnétisation, nettoyage, lecture	Têtes d'enregistrement, têtes d'effacement, cabestans, galets presseur	Démagnétiser les têtes d'enregistrement/lecture avec un seffaceur de tête. Nettoyer les têtes d'enregistrement/lecture, les têtes d'effacement, les cabestans et les galets presseur avec un coton-tige trempé dans de l'alcool.	
(2)	Azimet de tête d'enregistrement/lecture	SCC-1727, TCC-153, MTT-114, 10 kHz, -10 dBs	(B)	PLAY	Vis d'ajustement de l'azimet	Maximiser la sortie et ajuster pour que la figure de Lissajous s'approche d'une ligne inclinée sur 45°	(a)
II. Ajustement de la plaquette de circuits imprimés. Note: Commencer par effectuer le réglage de la vitesse double.							
(1)	Vitesse de bande (double)	SCC1727 TCC-110 MTT-114 3 kHz	(B)	MODE TEST 4 → 3 reliées FICHE SECTEUR BRANCHEE A UNE PRISE DE COURANT	A DECK: VR51 B DECK: VR53	Ajuster pour que la fréquence soit 6 kHz au centre de bande	
(2)	Vitesse de bande (normale)	SCC1727 TCC-110 MTT-111 3 kHz	(B)	TOUCHE FF GRANDE VITESSE TOUCHE DE LECTURE AVANT VITESSE NORMALE	A DECK: VR50 B DECK: VR52	Ajuster pour que la fréquence soit 3 kHz au centre de bande.	
III. Ajustement de la plaquette de circuit imprimé.							
(1)	Niveau de lecture	MTT-150 400 Hz MTT-256, SCC1727 315 Hz (160 mWb/m) MTT-256U, TCC-160 315 Hz (250 mWb/m)	(B)	PLAY	A DECK: VR1 (L) VR2 (R) B DECK: VR3 (L) VR4 (R)	Ajuster pour que la sortie de lecture soit de -1 dBs Ajuster pour que la sortie de lecture soit de -4 dBs Ajuster pour que la sortie de lecture soit de -0 dBs	
(2)	Courant de polarisation	1 kHz - 20 dBs	(B)	Ajuster les VR électroniques pour que la sortie de contrôle d'enregistrement soit de -20 dBs à 1 kHz puis enregistrer 1 kHz et 10 kHz réciproquement et les lire.	B DECK: VR9 (L) VR10 (R)	Enregistrer 1 kHz et 10 kHz réciproquement et ajuster pour qu'ils soient identiques au niveau de lecture.	
(3)	Niveau d'enregistrement (LEVEL)	1 kHz - 10 dBs	(B)	1 kHz - 10 dBs	B DECK (L): VR13 (R): VR14	Régler la résistance variable pour obtenir un niveau de lecture de -10 dB.	
(4)	FREQUENCE D'OSCILLATION DE POLARISATION	Mettre en place des cassettes non enregistrées dans les platines A et B		Raccorder le compteur de fréquence enter E. H et GND de la platine A. enter E. H et GND de la platine B.	Emregistrement DECK B: L21 (X28-1380-01)	Regler de manière à ce que le compteur de fréquence indique 105 kHz.	
(5)	FUITE DE POLARISATION	Mettre en place une cassette non enregistrée dans la platine A	(B)	Mettre en place une bande metal et copier en mode de vitesse élevée.	L9 (L) L10 (R)	Minimum (Point)	

ABGLEICH

Reihenfolge	Gegenstand	Eingangs-Einstellung	Ausgangs-Einstellung	Deck-Einstellung	Abgleichpunkte	Abgleichmethode	Abbildung	
Wenn nicht anders angegeben, die einzelnen Schalter wie folgt einstellen: TAPE: NORMAL DOLBY: OFF INPUT/ LINE								
I. Kassettenmechanismus-Teil (Einstellung des Aufnahme-/Wiedergabekopfes)								
(1)	Entmagnetisierung und Reinigung	—	—	Ausschalten, Entmagnetisierung. Reinigung, Wiedergabe	Aufnahmeköpfe Löschköpfe, Tonwellen, Andruckrollen	Die Aufnahme-/Wiedergabeköpfe mit einem Tonkopf-Entmagnetisierer entmagnetisieren. Die Aufnahme-/Wiedergabeköpfe, die Löschköpfe, die Tonwellen und die Andruckrollen mit einem mit Alkohol befeuchteten Wattestäbchen reinigen.		
(2)	Azimuth des Aufnahme-/Wiedergabekopfes	SCC-1727, TCC-153, MTT-114, 10 kHz, -10 dBs	(B)	PLAY	Azimuth-Einstellschraube	Den Ausgang maximieren und so einstellen, daß die Lissajousfigur sich einer um 45° geneigten Linie annähert.	(a)	
II. Leiterplatten-Einstellung. Hinweis: Zuerst die Doppelgeschwindigkeitsenstellung durchführen.								
(1)	Bandgeschwindigkeit (doppelt)	SCC1727 TCC-110 MTT-114 3 kHz	(B)	TEST-MODUS [4] → [3] kurz NETSTECKER-ANSCHL AN NETZ-STECKDOSE	A DECK: VR51 B DECK: VR53	So einstellen, daß die Frequenz in der Bandmitte 6 kHz beträgt		
(2)	Bandgeschwindigkeit (normale)	SCC1727 TCC-110 MTT-111 3 kHz	(B)	FF KEY HIGH-SPEED F. PLAY KEY NOR-SPEED	A DECK: VR50 B DECK: VR52	So einstellen, daß die Frequenz in der Bandmitte 3 kHz beträgt		
III. Leiterplatten-Einstellung (X28-2300)								
(1)	Wiederbepegel	MTT-150 400 Hz	(B)	PLAY	A DECK: VR1 (L) VR2 (R) B DECK: VR3 (L) VR4 (R)	So einstellen, daß der Wiedergabe-Ausgang -1 dBs beträgt		
		MTT-256, SCC1727 315 Hz (160 mWb/m)				So einstellen, daß der Wiedergabe-Ausgang -4 dBs beträgt		
		MTT-256U, TCC-160 315 Hz (250 mWb/m)				So einstellen, daß der Wiedergabe-Ausgang -0 dBs beträgt		
(2)	Vormagnetisierungsstrom	1 kHz - 20 dBs	(B)	Die elektronischen Regewiderstände so einstellen, daß der Aufnahme-monitor-Ausgang -20 dBs bei 1 kHz beträgt, dann 1 kHz und 10 kHz abwechselnd aufnehmen und wiedergeben.	B DECK: VR 9(L) VR 10(R)	1 kHz und 10 kHz abwechselnd aufnehmen und so einstellen, daß sie im Wiedergabepegel identisch sind.		
(3)	AUFNAHMEPEGEL	1 kHz - 10 dBs	(B)	1 kHz - 10 dBs	B DECK (L): VR13 (R): VR14	Den Stellwiderstand so einstellen, daß ein Wiedergabepegel von -10 dBs erhalten wird		
(4)	VORMAGNETISIERUNGS OSZILLATIONS-FREQUENZ	Unbespielte Kassetten in Deck A und B einsetzen.		Den Frequenzzähler zwischen E, H und GND von Deck A und zwischen E, H und GND von Deck B anschließen.	REC	DECK B: L21	So einstellen, daß 105 kHz auf dem Frequenzzähler angezeigt wird.	
(5)	VORMAGNETISIERUNGSSTREUUNG	Eine unbespielte Kassette in Deck A einsetzen.	(B)	Eine Metal I bandkassette einsetzen und mit hoher Geschwindigkeit überspielen.	L9 (L) L10 (R)	Minimum (Punkt)		

KX-W893

ADJUSTMENT/REGLAGE/ABGLEICH

SYSTEM CONNECTIONS

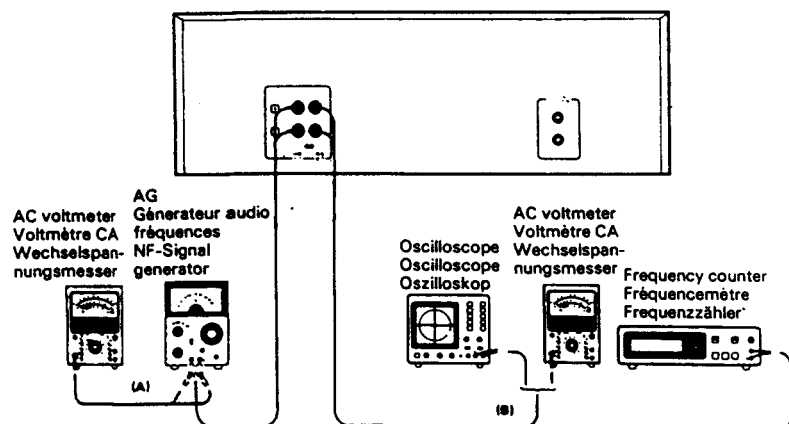

(a) AZIMUTH ADJUSTMENT SCREW

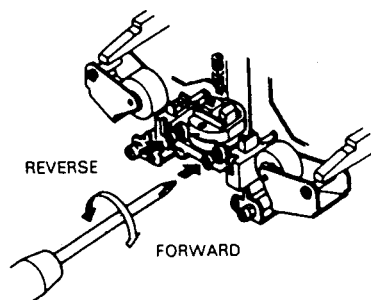

KX-W893 KX-W893

WIRING DIAGRAM

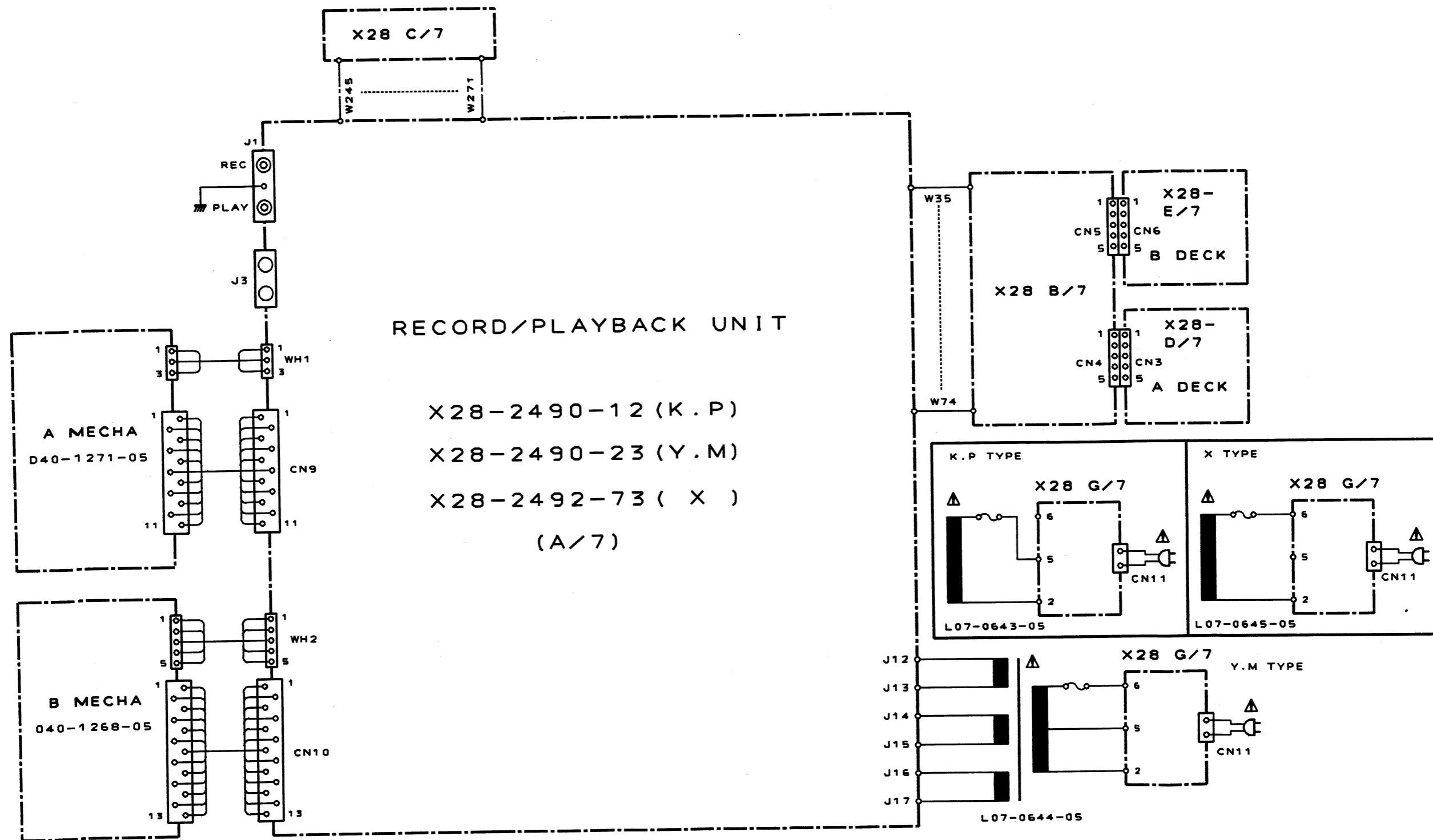

PC BOARD (Component side view)

RECORD/PLAYBACK AMPLIFIER UNIT (X28-2490-12 : K, P, X 0-23 : M, X)

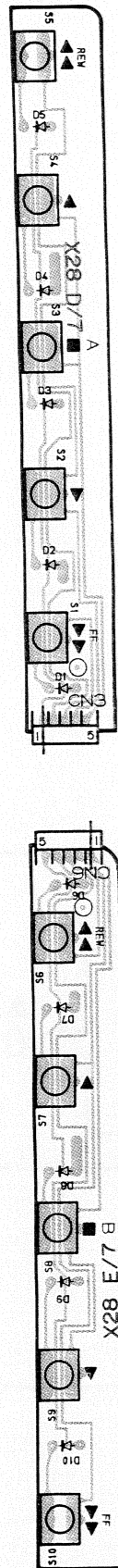

FRONT ←

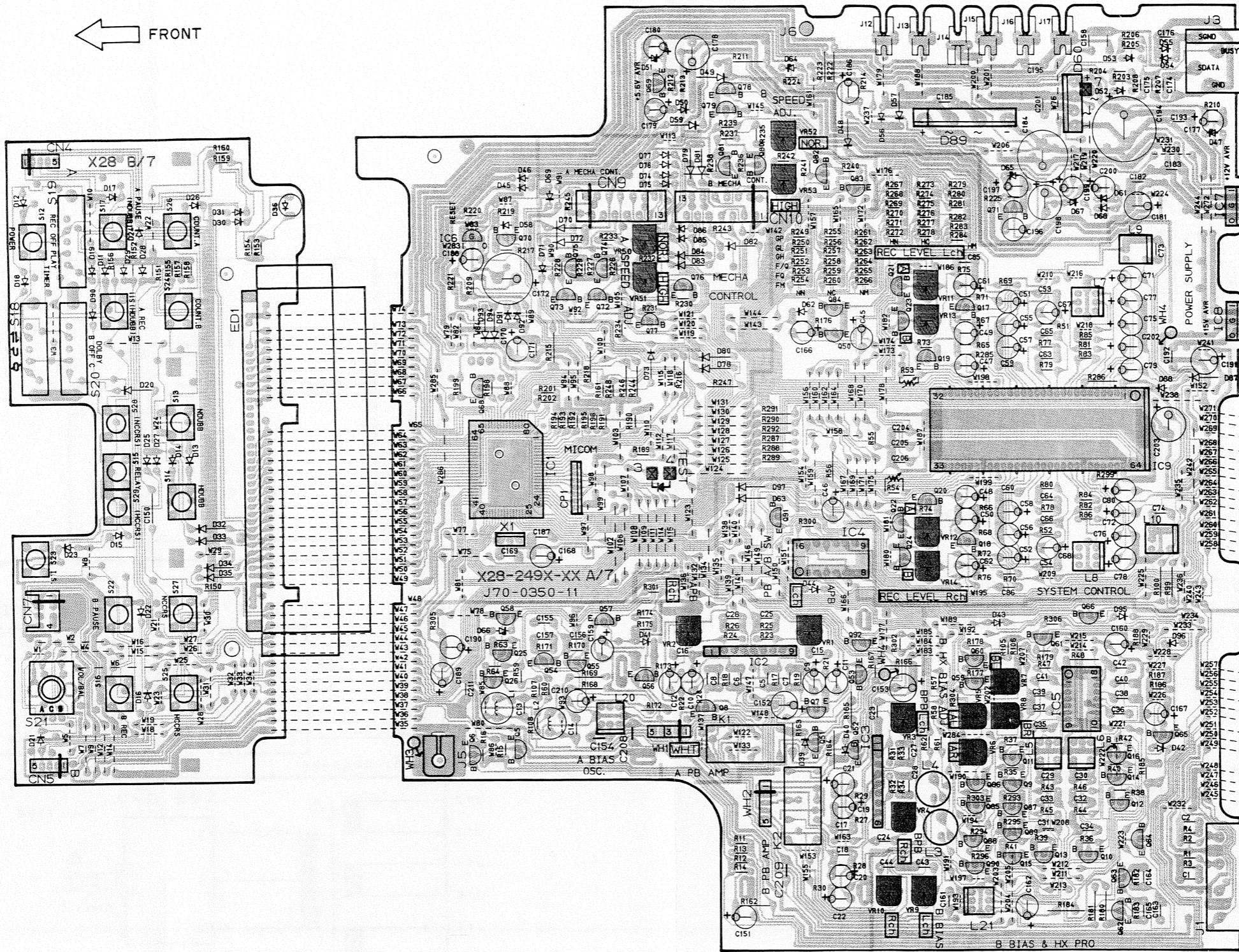

SYSTEM CONTROL

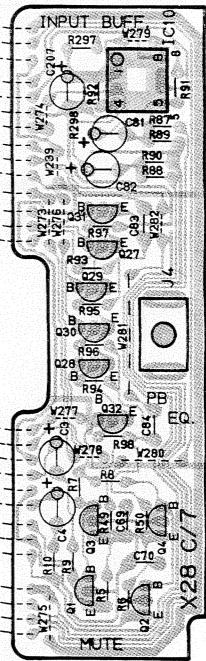
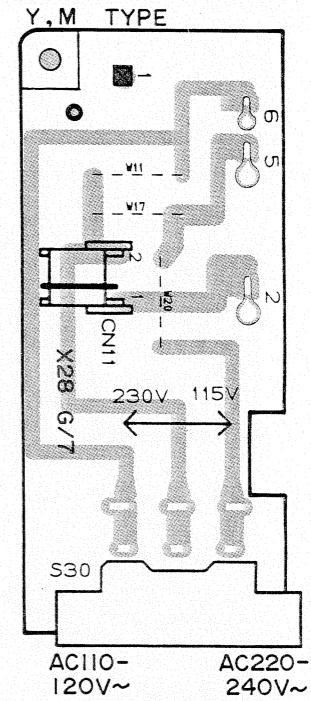

L R REC PLAY LINE IN

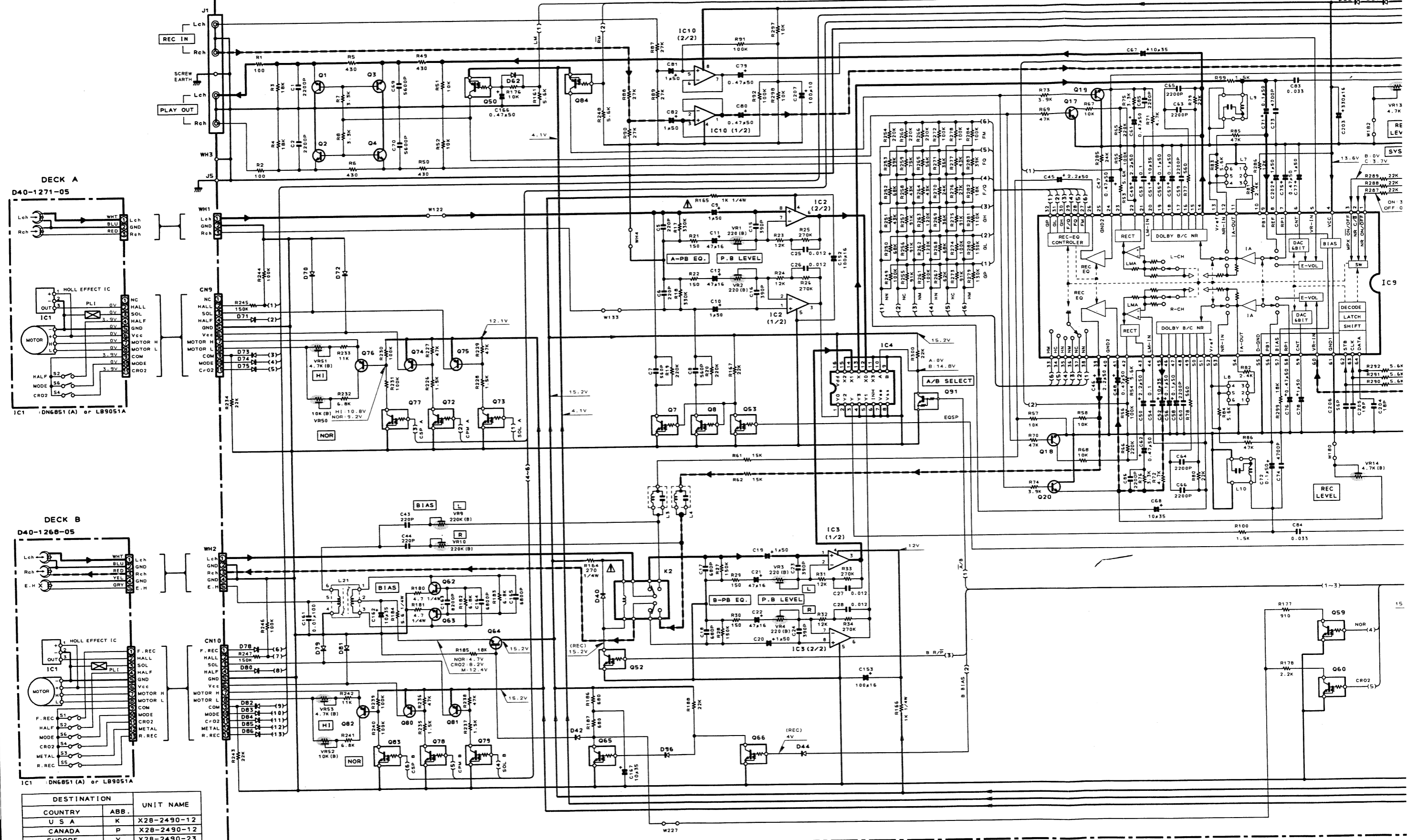

DESTINATION		UNIT NAME
COUNTRY	ABB.	
U S A	K	X28-2490-12
CANADA	P	X28-2490-12
EUROPE	Y	X28-2490-23
OTHER AREAS	M	X28-2490-23
AUSTRALIA	X	X28-2492-73

DC
ter v
slight
or/a
the

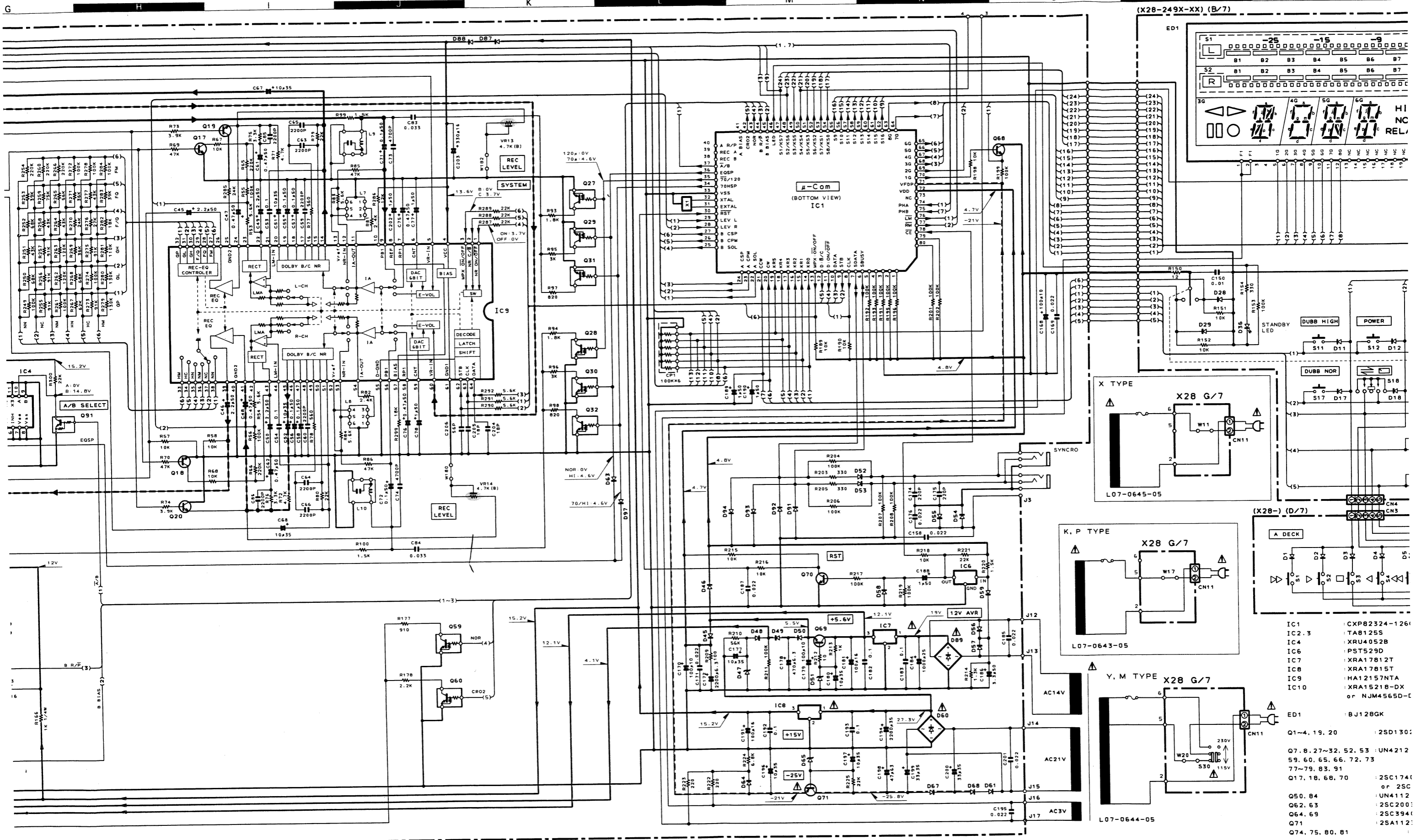

DC voltages are as measured with a high impedance voltmeter with a cassette loaded at playback mode. Values may vary slightly due to variations between individual instruments or/and units. Bias circuit DC voltages are as measured while in the record mode.

Les tensions c.c. doivent être mesurées avec un voltmètre à haute impédance, une cassette étant insérée en mode de lecture. Les valeurs peuvent différer légèrement du fait des variations inhérentes aux appareils et aux instruments de mesure individuels. Les tensions c.c. du circuit de polarité doivent être mesurées, l'appareil étant en mode d'enregistrement.

Die angegebenen Gleichspannungswerte wurden bei eingesetzter Cassette in der Wiedergabe mit einem hochohmigen Spannungsmesser gemessen. Dabei schwanken die Meßwerte aufgrund von Unterschieden zwischen einzelnen Instrumenten oder Geräten u. U. geringfügig. Die angegebenen Gleichspannungswerte der Vormagnetisierungsschaltung wurden in der Aufnahme-Betriebsart gemessen.

CAUTION: For continued safety, repairs only with manufacturer's recd parts list). ⚠ Indicates safety critical risk of electric shock, leakage-current shall be carried out (exposed parts are the supply circuit) before the appliance is repaired.

- IC1 : CXP82324-126
- IC2,3 : TA8125S
- IC4 : XRU4052B
- IC6 : PST529D
- IC7 : XRA17812T
- IC8 : XRA17815T
- IC9 : HA12157NTA
- IC10 : XRA15218-DX or NJM4565D-1
- ED1 : BJ128GK
- Q1~4, 19, 20 : 2SD130
- Q7, 8, 27~32, 52, 53 : UN4212
- 59, 60, 65, 66, 72, 73 : 77~79, 83, 91
- Q17, 18, 68, 70 : 2SC174 or 2SC or UN4112
- Q62, 63 : 2SC200
- Q64, 69 : 2SC394
- Q71 : 2SA112
- Q74, 75, 80, 81

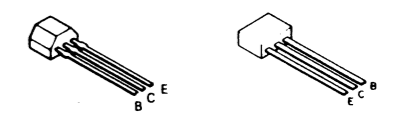
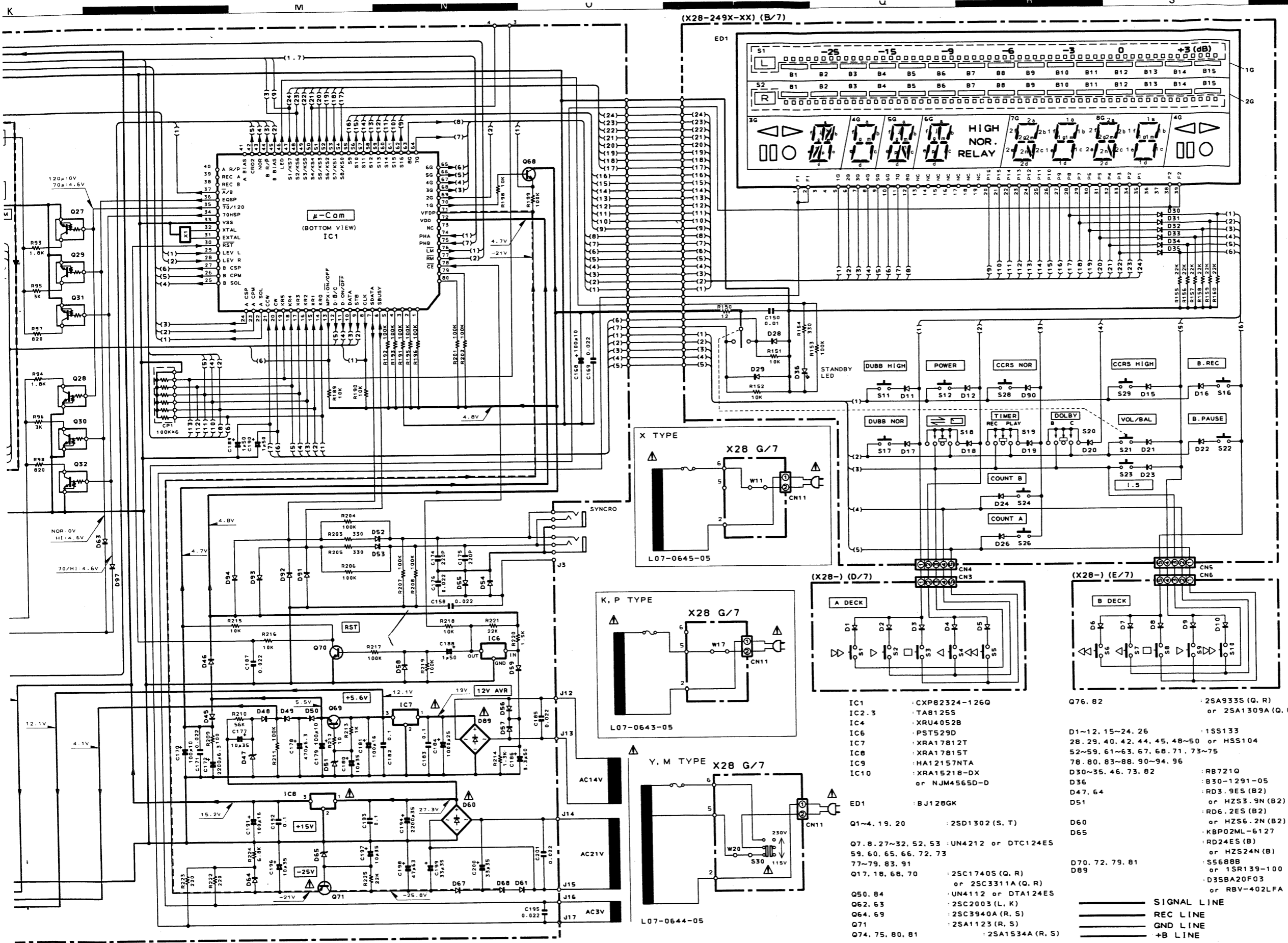

DTA124ES
DTC124ES
UN4112
2SA933S
2SC1740S

UN4212
2SA1309A
2SC3311A

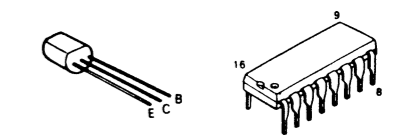

2SA1123
2SA1534A
2SC2003
2SC3940A
2SD1302

XRU4052B

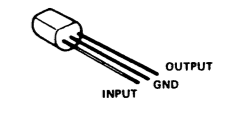

PST529D

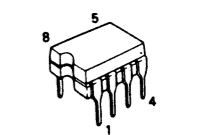

NJM4565D-D

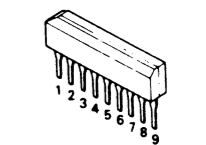

TA8125S

- | | | | |
|------------------------|---|---------------------------------|--|
| IC1 | : CXP82324-126Q | Q76, 82 | : 2SA933S (Q, R)
or 2SA1309A (Q, R) |
| IC2, 3 | : TA8125S | D1-12, 15-24, 26 | : 1S5133 |
| IC4 | : XRU4052B | 28, 29, 40, 42, 44, 45, 48-50 | : HSS104 |
| IC6 | : PST529D | 52-59, 61-63, 67, 68, 71, 73-75 | |
| IC7 | : XRA17812T | 78, 80, 83-88, 90-94, 96 | |
| IC8 | : XRA17815T | D30-35, 46, 73, 82 | : RB721Q |
| IC9 | : HA12157NTA | D36 | : B30-1291-05 |
| IC10 | : XRA15218-DX
or NJM4565D-D | D47, 64 | : RD3, 9ES (B2) |
| ED1 | : BJ128GK | D51 | : RD6, 2ES (B2)
or HZS3, 9N (B2) |
| Q1-4, 19, 20 | : 2SD1302 (S, T) | D60 | : RD6, 2ES (B2) |
| Q7, 8, 27-32, 52, 53 | : UN4212 or DTC124ES | D65 | : or HZS6, 2N (B2)
KBP02ML-6127 |
| 59, 60, 65, 66, 72, 73 | | D70, 72, 79, 81 | : RD24ES (B)
or HZS24N (B) |
| 77-79, 83, 91 | | D89 | : S5688B
or 1SR139-100 |
| Q17, 18, 68, 70 | : 2SC1740S (Q, R)
or 2SC3311A (Q, R) | | : D35BA20F03
or RBV-402LFA |
| Q50, 84 | : UN4112 or DTA124ES | | |
| Q62, 63 | : 2SC2003 (L, K) | | |
| Q64, 69 | : 2SC3940A (R, S) | | |
| Q71 | : 2SA1123 (R, S) | | |
| Q74, 75, 80, 81 | : 2SA1534A (R, S) | | |

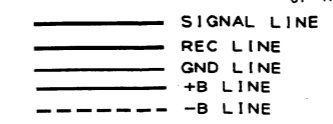

ages are as measured with a high impedance voltmeter on a cassette loaded at playback mode. Values may vary due to variations between individual instruments units. Bias circuit DC voltages are as measured while in rd mode.

Les tensions c.c. doivent être mesurées avec un voltmètre à haute impédance, une cassette étant insérée en mode de lecture. Les valeurs peuvent différer légèrement du fait des variations inhérentes aux appareils et aux instruments de mesure individuels. Les tensions c.c. du circuit de polarité doivent être mesurées, l'appareil étant en mode d'enregistrement.

Die angegebenen Gleichspannungswerte wurden bei eingesetzter Cassette in der Wiedergabe mit einem hochohmigen Spannungsmesser gemessen. Dabei schwanken die Meßwerte aufgrund von Unterschieden zwischen einzelnen Instrumenten und Geräten u. U. geringfügig. Die angegebenen Gleichspannungswerte der Vormagnetisierungsschaltung wurden in der Aufnahme-Betriebsart gemessen.

CAUTION: For continued safety, replace safety critical components only with manufacturer's recommended parts (refer to parts list). Δ Indicates safety critical components. To reduce the risk of electric shock, leakage-current or resistance measurements shall be carried out (exposed parts are acceptably insulated from the supply circuit) before the appliance is returned to the customer.

Y26-3600-10



EXPLODED VIEW (MECHANISM UNIT)

EXPLODED VIEW (UNIT)

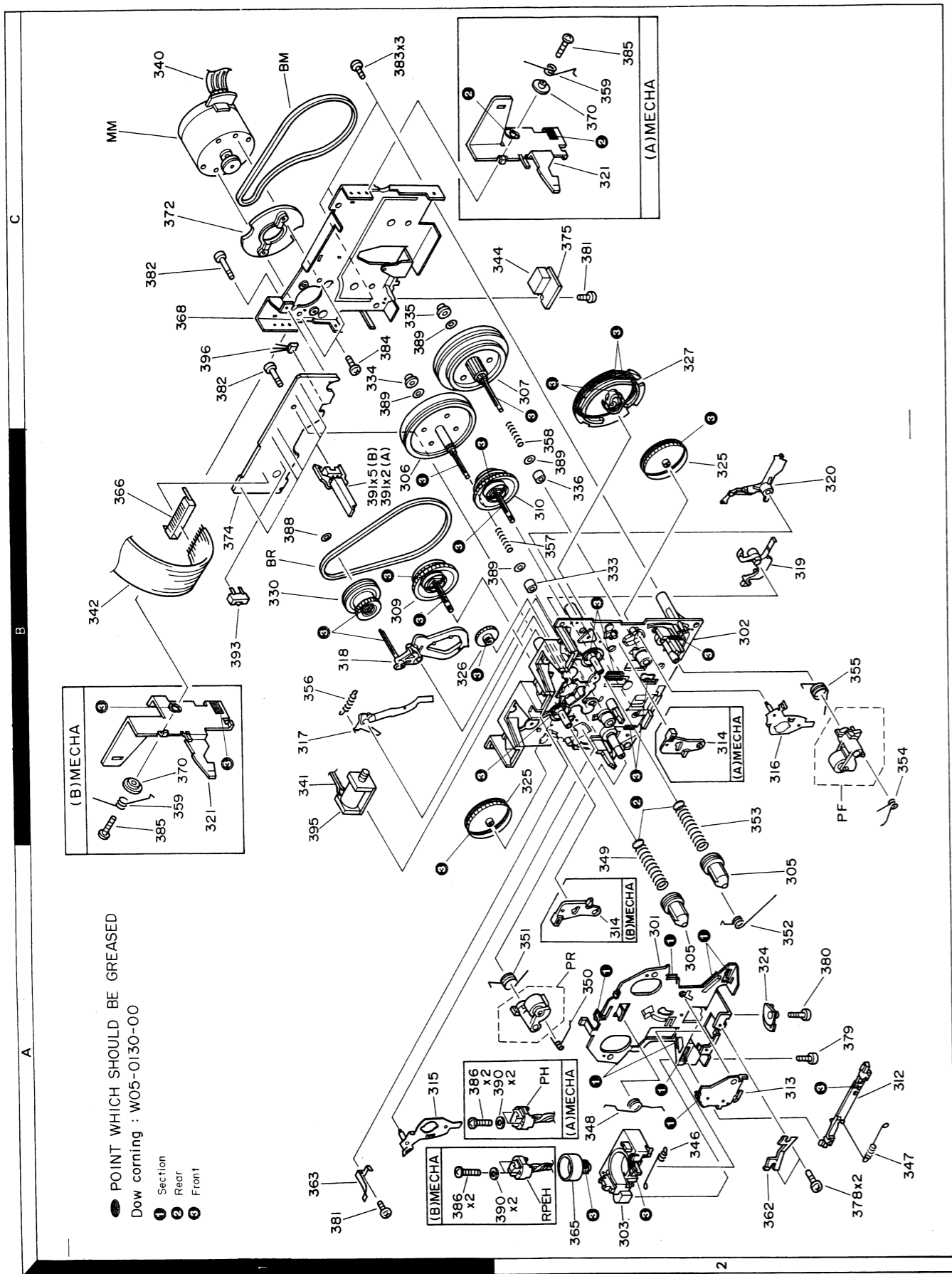

Parts with the exploded numbers larger than 700 are not supplied.

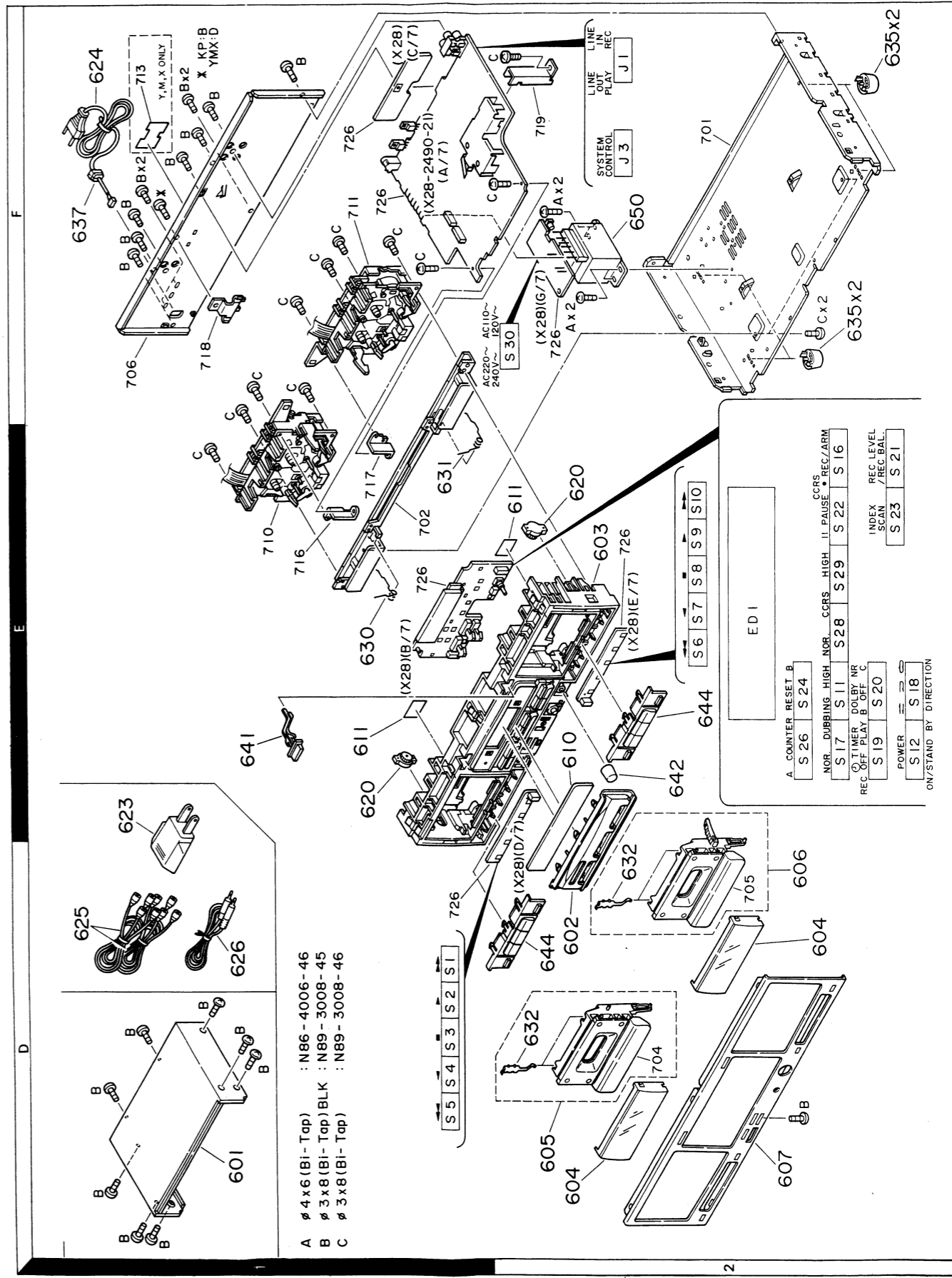

Parts with the exploded numbers larger than 700 are not supplied.

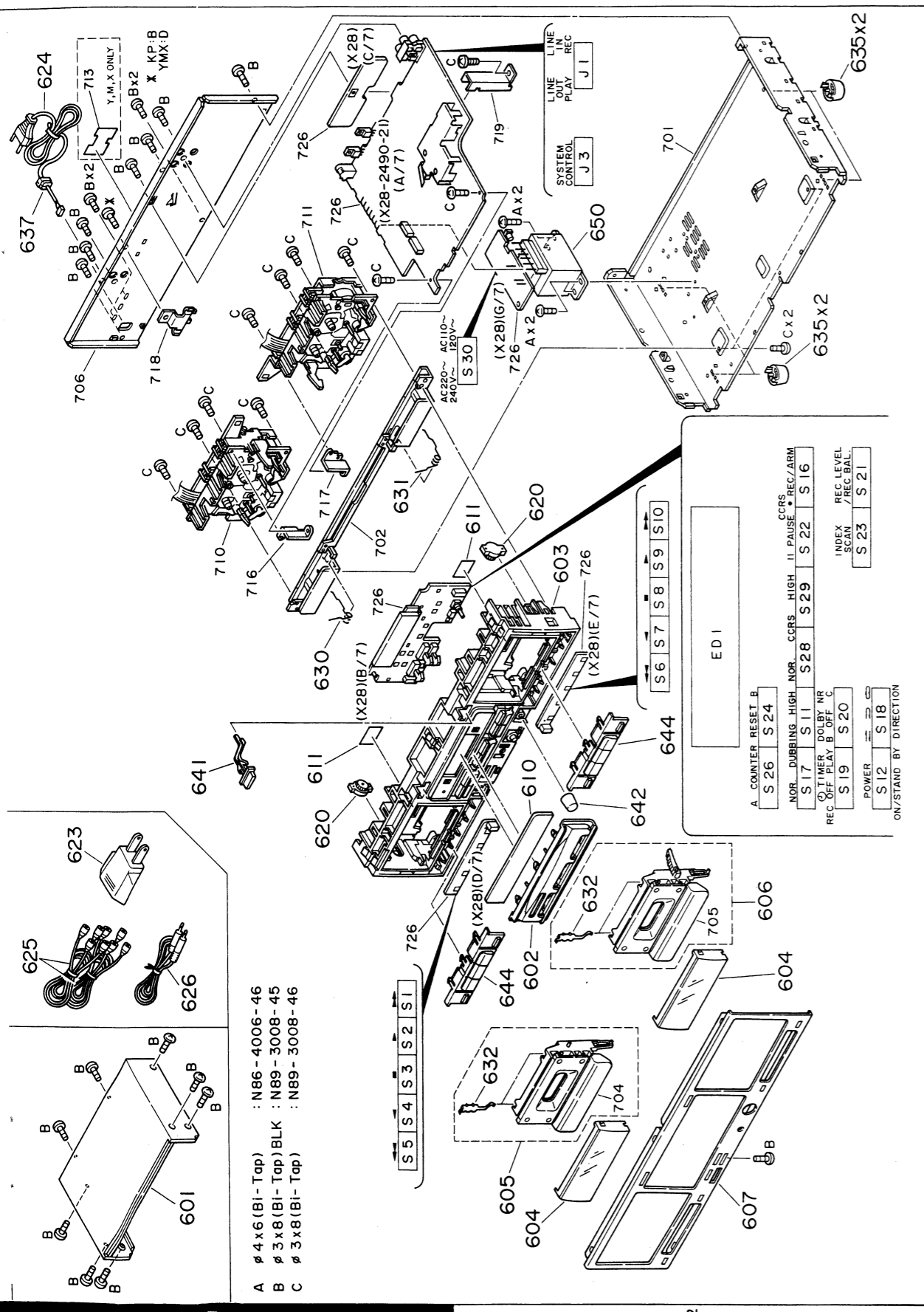

Parts with the exploded numbers larger than 700 are not supplied.

PARTS LIST

* New Parts

Parts without Parts No. are not supplied.

Les articles non mentionnés dans le Parts No. ne sont pas fournis.

Teile ohne Parts No. werden nicht geliefert.

Ref. No.	Address	New Parts	Parts No.	Description	Destination	Remarks
参照番号	位置	新	部品番号	部品名 / 規格	仕向	備考
KX-W893						
601	1D	*	A01-3018-01	METALLIC CABINET		
602	2D	*	A21-1831-03	DRESSING PANEL		
603	2E	*	A22-1604-11	SUB PANEL		
604	2D	*	A53-1383-14	CASSETTE LID		
605	2D	*	A53-1402-03	CASSETTE HOLDER ASSY		
606	2D	*	A53-1404-03	CASSETTE HOLDER ASSY		
607	2D	*	A60-0327-02	PANEL		
610	2E	*	B03-2806-03	DRESSING PLATE		
611	1E, 2E	*	B07-1720-04	ESCUTCHEON		
-	-	-	B46-0092-13	WARRANTY CARD		K
-	-	-	B46-0094-03	WARRANTY CARD		Y
-	-	-	B46-0095-03	WARRANTY CARD		Y
-	-	-	B46-0096-33	WARRANTY CARD		X
-	-	*	B46-0121-23	WARRANTY CARD		P
-	-	*	B58-0513-04	CAUTION CARD (PRESET220-240)		Y
-	-	*	B60-1067-00	INSTRUCTION MANUAL (ENGLISH)		
-	-	*	B60-1068-00	INSTRUCTION MANUAL (FRENCH)		P
-	-	*	B60-1069-00	INSTRUCTION MANUAL (CHINESE)		M
-	-	*	B60-1070-00	INSTRUCTION MANUAL (SPANISH)		M
620	1E, 2E	-	D39-0176-05	DAMPER		
△ 623	1E	-	E03-0115-05	AC PLUG ADAPTER		M
△ 624	1F	-	E30-2592-15	AC POWER CORD		M
△ 624	1F	-	E30-2605-05	AC POWER CORD		Y
△ 624	1F	-	E30-2650-05	AC POWER CORD		KP
△ 624	1F	*	E30-2717-05	AC POWER CORD		X
625	1D	-	E30-0505-05	AUDIO CORD		
626	1D	-	E30-2733-05	CORD WITH PLUG		
630	1E	*	G01-3516-04	TORSION COIL SPRING		
631	1E	*	G01-3517-04	TORSION COIL SPRING		
632	1D	-	G02-0944-04	FLAT SPRING		
-	-	*	H13-0116-04	CARTON BOARD		X
-	-	*	H50-0514-04	ITEM CARTON CASE		
-	-	-	H10-5129-12	POLYSTYRENE FOAMED FIXTURE		
-	-	-	H10-5130-12	POLYSTYRENE FOAMED FIXTURE		
-	-	-	H20-0554-04	PROTECTION COVER		M
-	-	-	H25-0232-04	PROTECTION BAG (235X350X0.03)		
-	-	-	H25-0330-04	PROTECTION BAG		KPYX
△ 635	2F	-	J02-0366-15	FOOT		
△ 637	1F	-	J42-0083-05	POWER CORD BUSHING		
641	1E	-	K29-3592-04	KNØB EJECT		
642	2E	*	K29-5627-04	KNØB REC LEVEL, REC BALANCE		
644	1D, 2E	*	K29-5626-03	KNØB PLAY		
△ 650	2F	*	L07-0643-05	POWER TRANSFORMER		KP
△ 650	2F	*	L07-0644-05	POWER TRANSFORMER		YM
△ 650	2F	*	L07-0645-05	POWER TRANSFORMER		X
A	2F	-	N86-4006-46	BINDING HEAD TAPTITE SCREW		
B	1D, 1F	-	N89-3008-45	BINDING HEAD TAPTITE SCREW		
C	1E, 1F	-	N89-3008-46	BINDING HEAD TAPTITE SCREW		
D	1F	-	N09-1777-05	SEMUS SCREW		YMX

L:Scandinavia

K:USA

P:Canada

Y:PX(Far East, Hawaii)

T:England

E:Europe

Y:AAFES(Europe)

X:Australia

M:Other Areas

△ indicates safety critical components.

PARTS LIST

× New Parts

Parts without Parts No. are not supplied.

Les articles non mentionnés dans le Parts No. ne sont pas fournis.

Telle ohne Parts No. werden nicht geliefert.

Ref. No. 参照番号	Address 位置	New Parts 新	Parts No. 部品番号	Description 部品名 / 規格	Desti- nation 仕 向	Re- marks 備考
RECORD/PLAYBACK AMPLIFIER UNIT (X28-2490-12 :K, P, X 0-23 : M, X)						
D36			B30-1291-05	LED(LN21CPSLX(V)-(TA4))		
C1 ,2			CQ92FM1H222J	MYLAR 2200PF J		
C5 ,6			CC45FSL1H221J	CERAMIC 220PF J		
C7 ,8			CK45FB1H561K	CERAMIC 560PF K		
C9 ,10			CE04KW1H010M	ELECTRØ 1.0UF 50WV		
C11 ,12			CE04KW1C470M	ELECTRØ 47UF 16WV		
C15 ,16			CK45FB1H391K	CERAMIC 390PF K		
C17 ,18			CK45FB1H681K	CERAMIC 680PF K		
C19 ,20			CE04KW1H010M	ELECTRØ 1.0UF 50WV		
C21 ,22			CE04KW1C470M	ELECTRØ 47UF 16WV		
C23 ,24			CK45FB1H391K	CERAMIC 390PF K		
C25 -28			CQ92FM1H123J	MYLAR 0.012UF J		
C43 ,44			CC45FSL1H221J	CERAMIC 220PF J		
C45 ,46			CE04KW1H2R2M	ELECTRØ 2.2UF 50WV		
C47 ,48			CE04KW1HR47M	ELECTRØ 0.47UF 50WV		
C49 ,50			CE04KW1H2R2M	ELECTRØ 2.2UF 50WV		
C51 ,52			CE04KW1V100M	ELECTRØ 10UF 35WV		
C53 ,54			CF92FV1H104J	MF 0.10UF J		
C55 -58			CE04KW1HOR1M	ELECTRØ 0.1UF 50WV		
C59 ,60			CQ92FM1H222J	MYLAR 2200PF J		
C61 ,62			CE04KW1HR47M	ELECTRØ 0.47UF 50WV		
C63 -66			CQ92FM1H222J	MYLAR 2200PF J		
C67 ,68			CE04KW1V100M	ELECTRØ 10UF 35WV		
C69 ,70			CQ92FM1H562J	MYLAR 5600PF J		
C71 ,72			CE04KW1HOR1M	ELECTRØ 0.1UF 50WV		
C73 ,74			CQ92FM1H472J	MYLAR 4700PF J		
C75 ,76			CE04KW1HR47M	ELECTRØ 0.47UF 50WV		
C77 ,78			CE04KW1H010M	ELECTRØ 1.0UF 50WV		
C79 ,80			CE04KW1HR47M	ELECTRØ 0.47UF 50WV		
C81 ,82			CE04KW1H010M	ELECTRØ 1.0UF 50WV		
C83 ,84			CF92FV1H333J	MF 0.033UF J		
C85 ,86			CQ92FM1H222J	MYLAR 2200PF J		
C150			C91-0769-05	CERAMIC 0.01UF K		
C152,153			CE04KW1C101M	ELECTRØ 100UF 16WV		
C158			CK45FF1H223Z	CERAMIC 0.022UF Z		
C161			CQ93HP2A103J	MYLAR 0.010UF J		
C162			CE04KW1V100M	ELECTRØ 10UF 35WV		
C163			CQ92FM1H822J	MYLAR 8200PF J		
C164,165			CQ92FM1H682J	MYLAR 6800PF J		
C166			CE04KW1HR47M	ELECTRØ 0.47UF 50WV		
C167			CE04KW1V100M	ELECTRØ 10UF 35WV		
C168			CE04KW1A101M	ELECTRØ 100UF 10WV		
C169			CK45FF1H223Z	CERAMIC 0.022UF Z		
C170			CE04KW1A101M	ELECTRØ 100UF 10WV		
C171			CK45FF1H223Z	CERAMIC 0.022UF Z		
C172			CE04EWOJ222M	ELECTRØ 2200UF 6.3WV		
C174,175			CC45FSL1H221J	CERAMIC 220PF J		
C176			CK45FF1H223Z	CERAMIC 0.022UF Z		
C177			CE04KW1V100M	ELECTRØ 10UF 35WV		
C178			CE04KWOJ471M	ELECTRØ 470UF 6.3WV		
C179			CE04KW1A101M	ELECTRØ 100UF 10WV		
C180			CE04KW1V100M	ELECTRØ 10UF 35WV		

L:Scandinavia

K:USA

P:Canada

Y:PX(Far East, Hawaii)

T:England

E:Europe

Y:AAFES(Europe)

X:Australia

M:Other Areas

△印は安全部品

△ indicates safety critical components.

PARTS LIST

× New Parts

Parts without Parts No. are not supplied.

Les articles non mentionnes dans le Parts No. ne sont pas fournis.

Telle ohne Parts No. werden nicht geliefert.

Ref. No. 参照番号	Address 位置	New Parts 新	Parts No. 部品番号	Description 部品名 / 規格	Desti- nation 向	Re- marks 備考
C181			CE04KW1C101M	ELECTRO 100UF 16WV		
C182, 183			CF92FV1H104J	MF 0.10UF J		
C184			CE04EW1E102M	ELECTRO 1000UF 25WV		
C185			CK45FF1H223Z	CERAMIC 0.022UF Z		
C186			CE04KW1H3R3M	ELECTRO 3.3UF 50WV		
C187			CK45FF1H223Z	CERAMIC 0.022UF Z		
C188-190			CE04KW1H010M	ELECTRO 1.0UF 50WV		
C191			CE04KW1C101M	ELECTRO 100UF 16WV		
C192, 193			CF92FV1H104J	MF 0.10UF J		
C194		*	C90-3482-05	ELECTRO 2200UF 35WV		
C195			CK45FF1H223Z	CERAMIC 0.022UF Z		
C196, 197			CE04KW1V100M	ELECTRO 10UF 35WV		
C198			CE04KW1J470M	ELECTRO 47UF 63WV		
C199, 200			CE04KW1V330M	ELECTRO 33UF 35WV		
C201			CK45FF1H223Z	CERAMIC 0.022UF Z		
C202			CE04KW1H010M	ELECTRO 1.0UF 50WV		
C203			CE04KW1C331M	ELECTRO 330UF 16WV		
C204, 205			CC45FSL1H180J	CERAMIC 18PF J		
C206			CC45FSL1H560J	CERAMIC 56PF J		
C207			CE04KW1A101M	ELECTRO 100UF 10WV		
C211			CK45FF1H223Z	CERAMIC 0.022UF Z		
J1		*	E63-0071-05	PHONE JACK LINE IN/OUT		
J3			E11-0188-05	MINIATURE PHONE JACK SYNCHRO		
J6			J11-0098-05	WIRE CLAMPER		
L3 ,4			L39-0171-05	TRAP COIL		
L7 ,8		*	L79-1209-05	LC FILTER		
L9 ,10			L39-0126-05	TRAP COIL		
L21		*	L32-0555-05	BIAS OSCILATING COIL		
X1			L78-0294-05	RESONATOR 10.000MHz		
CP1			R90-0500-05	MULTI-COMP 100KX6 J 1/4W		
R164			RD14NB2E271J	RD 270 J 1/4W		
R165, 166			RD14NB2E102J	RD 1.0K J 1/4W		
R184			RD14NB2E5R6J	RD 5.6 J 1/4W		
VR1 -4			R12-0605-05	TRIMMING POT.(220)		
VR9 ,10			R12-5081-05	TRIMMING POT.(220K)		
VR13, 14			R12-1619-05	TRIMMING POT.(4.7K)		
VR50			R12-3685-05	TRIMMING POT.(10K)		
VR51			R12-1619-05	TRIMMING POT.(4.7K)		
VR52			R12-3685-05	TRIMMING POT.(10K)		
VR53			R12-1619-05	TRIMMING POT.(4.7K)		
K2			S76-0018-05	MAGNETIC RELAY		
S1 -12			S40-1064-05	PUSH SWITCH		
S16 ,17			S40-1064-05	PUSH SWITCH		
S18 -20			S31-1036-05	SLIDE SWITCH		
S22 -24			S40-1064-05	PUSH SWITCH		
S26			S40-1064-05	PUSH SWITCH		
S28 ,29			S40-1064-05	PUSH SWITCH		
S30			S31-2131-05	SLIDE SWITCH (POWER TYPE)	YM	
S21		*	T99-0531-05	SPEED DETECTOR		
D1 -12			HSS104	DIODE		
D1 -12			1SS133	DIODE		

L:Scandinavia

K:USA

P:Canada

Y:PX(Far East, Hawaii)

T:England

E:Europe

Y:AAFES(Europe)

X:Australia

M:Other Areas

△ indicates safety critical components.

KX-W893

PARTS LIST

× New Parts

Parts without Parts No. are not supplied.

Les articles non mentionnes dans le Parts No. ne sont pas fournis.

Teile ohne Parts No. werden nicht geliefert.

Ref. No. 参照番号	Address 位置	New Parts 新	Parts No. 部品番号	Description 部品名 / 規格	Desti- nation 仕向	Re- marks 備考
D15 -24			HSS104	DIODE		
D15 -24			1SS133	DIODE		
D26			HSS104	DIODE		
D26			1SS133	DIODE		
D28 ,29			HSS104	DIODE		
D28 ,29			1SS133	DIODE		
D30 -35			RB721Q	DIODE		
D40			HSS104	DIODE		
D40			1SS133	DIODE		
D42			HSS104	DIODE		
D42			1SS133	DIODE		
D44 ,45			HSS104	DIODE		
D44 ,45			1SS133	DIODE		
D46			RB721Q	DIODE		
D47			HZS3.9N(B2)	ZENER DIODE		
D47			RD3.9ES(B2)	ZENER DIODE		
D48 -50			HSS104	DIODE		
D48 -50			1SS133	DIODE		
D51			HZS6.2N(B2)	ZENER DIODE		
D51			RD6.2ES(B2)	ZENER DIODE		
D52 -59			HSS104	DIODE		
D52 -59			1SS133	DIODE		
D60			KBPO2ML-6127	DIODE		
D61 -63			HSS104	DIODE		
D61 -63			1SS133	DIODE		
D64			HZS3.9N(B2)	ZENER DIODE		
D64			RD3.9ES(B2)	ZENER DIODE		
D65			HZS24N(B)	ZENER DIODE		
D65			RD24ES(B)	ZENER DIODE		
D67 ,68			HSS104	DIODE		
D67 ,68			1SS133	DIODE		
D70			S5688B	DIODE		
D70			1SR139-100	DIODE		
D71			HSS104	DIODE		
D71			1SS133	DIODE		
D72			S5688B	DIODE		
D72			1SR139-100	DIODE		
D73			RB721Q	DIODE		
D74 ,75			HSS104	DIODE		
D74 ,75			1SS133	DIODE		
D78			HSS104	DIODE		
D78			1SS133	DIODE		
D79			S5688B	DIODE		
D79			1SR139-100	DIODE		
D80			HSS104	DIODE		
D80			1SS133	DIODE		
D81			S5688B	DIODE		
D81			1SR139-100	DIODE		
D82			RB721Q	DIODE		
D82 -88			HSS104	DIODE		
D82 -88			1SS133	DIODE		
D89			D3SBA20F03	DIODE		
D89			RBV-402LFA	DIODE		
D90 -94			HSS104	DIODE		
D90 -94			1SS133	DIODE		

L:Scandinavia

K:USA

P:Canada

Y:PX(Far East, Hawaii)

T:England

E:Europe

Y:AAFES(Europe)

X:Australia

M:Other Areas

△ indicates safety critical components.

PARTS LIST

* New Parts

Parts without Parts No. are not supplied.

Les articles non mentionnes dans le Parts No. ne sont pas fournis.

Teile ohne Parts No. werden nicht geliefert.

Ref. No. 参照番号	Address 位置	New Parts 新	Parts No. 部品番号	Description 部品名 / 規格	Desti- nation 仕向	Re- marks 備考
D96			HSS104	DIODE		
D96			1SS133	DIODE		
ED1		*	BJ128GK	INDICATOR TUBE		
IC1		*	CXP82324-126Q	IC(8BIT MICROPROCESSOR)		
IC2 ,3			TA8125S	IC(2CH PRE AMP)		
IC4			XRU4052B	IC(MULTIPLEXER/DEMULTIPLEXER)		
IC6			PST529D	IC(SYSTEM RESET)		
IC7			XRA17812T	IC		
IC8			XRA17815T	IC		
IC9		*	HA12157NTA	IC		
IC10			NJM4565D-D	IC(OP AMP X2)		
IC10			XRA15218-DX	IC(OP AMP X2)		
Q1 -4			2SD1302(S,T)	TRANSISTOR		
Q7 ,8			DTC124ES	DIGITAL TRANSISTOR		
Q7 ,8			UN4212	TRANSISTOR		
Q17 ,18			2SC1740S(Q,R)	TRANSISTOR		
Q17 ,18			2SC3311A(Q,R)	TRANSISTOR		
Q19 ,20			2SD1302(S,T)	TRANSISTOR		
Q27 -32			DTC124ES	DIGITAL TRANSISTOR		
Q27 -32			UN4212	TRANSISTOR		
Q50			DTA124ES	DIGITAL TRANSISTOR		
Q50			UN4112	TRANSISTOR		
Q52 ,53			DTC124ES	DIGITAL TRANSISTOR		
Q52 ,53			UN4212	TRANSISTOR		
Q59 ,60			DTC124ES	DIGITAL TRANSISTOR		
Q59 ,60			UN4212	TRANSISTOR		
Q62 ,63			2SC2003(L,K)	TRANSISTOR		
Q64			2SC3940A(R,S)	TRANSISTOR		
Q65 ,66			DTC124ES	DIGITAL TRANSISTOR		
Q65 ,66			UN4212	TRANSISTOR		
Q68			2SC1740S(Q,R)	TRANSISTOR		
Q68			2SC3311A(Q,R)	TRANSISTOR		
Q69			2SC3940A(R,S)	TRANSISTOR		
Q70			2SC1740S(Q,R)	TRANSISTOR		
Q70			2SC3311A(Q,R)	TRANSISTOR		
Q71			2SA1123(R,S)	TRANSISTOR		
Q72 ,73			DTC124ES	DIGITAL TRANSISTOR		
Q72 ,73			UN4212	TRANSISTOR		
Q74 ,75			2SA1534A(R,S)	TRANSISTOR		
Q76			2SA1309A(Q,R)	TRANSISTOR		
Q76			2SA933S(Q,R)	TRANSISTOR		
Q77 -79			DTC124ES	DIGITAL TRANSISTOR		
Q77 -79			UN4212	TRANSISTOR		
Q80 ,81			2SA1534A(R,S)	TRANSISTOR		
Q82			2SA1309A(Q,R)	TRANSISTOR		
Q82			2SA933S(Q,R)	TRANSISTOR		
Q83			DTC124ES	DIGITAL TRANSISTOR		
Q83			UN4212	TRANSISTOR		
Q84			DTA124ES	DIGITAL TRANSISTOR		
Q84			UN4112	TRANSISTOR		
Q91			DTC124ES	TRANSISTOR		
Q91			UN4212	TRANSISTOR		
MECHANISM ASS'Y (D40-1271-05 : A DECK, 8-05 : B DECK)						
301	2A	*	A10-3053-08	HEAD BASE CHASSIS CALKED ASSY		

L:Scandinavia

K:USA

P:Canada

Y:PX(Far East, Hawaii)

T:England

E:Europe

Y:AAFES(Europe)

X:Australia

M:Other Areas

⚠ indicates safety critical components.

KX-W893

PARTS LIST

* New Parts

Parts without Parts No. are not supplied.

Les articles non mentionnés dans le Parts No. ne sont pas fournis.

Teile ohne Parts No. werden nicht geliefert.

Ref. No. 参照番号	Address 位置	New Parts 新	Parts No. 部品番号	Description 部品名 / 規格	Desti- nation 仕向	Re- marks 備考
302	2B	*	A10-3054-08	MAIN CHASSIS CALKED ASSY		
303	2A	*	A15-0083-08	HEAD FLAME		
305	2A	*	B09-0243-08	REEL CAP		
306	1B	*	D01-0154-08	FLYWHEEL ASSY L		
307	2C	*	D01-0155-08	FLYWHEEL ASSY R		
309	1B	*	D03-0401-08	REEL DESK ASSY(REVERSE)		
310	2B	*	D03-0402-08	REEL DESK ASSY(FORWARD)		
312	2A	*	D10-3394-08	HEAD LEVER		
313	2A	*	D10-3395-08	ASSIST ARM ASSY		
314	2A, 2B	*	D10-3396-08	EJECT LOCK LEVER		
315	1A	*	D10-3397-08	PLAY ARM L		
316	2B	*	D10-3398-08	PLAY ARM R		
317	1B	*	D10-3399-08	REVERS ARM		
318	1B	*	D10-3400-08	FR ARM		
319	2B	*	D10-3401-08	BRAKE ARM		
320	2B	*	D10-3402-08	TRIGGER ARM		
321	1B	*	D10-3403-08	EJECT ARM		B
321	2C	*	D10-3404-08	EJECT ARM		A
324	2A	*	D13-1551-08	HEAD ARM GEAR		
325	2B	*	D13-1552-08	PLAY GEAR		
326	1B	*	D13-1553-08	PERST FORWARD GEAR		
327	2C	*	D13-1554-08	CAM GEAR		
330	1B	*	D15-0352-08	FR PULLEY ASSY		
333	2B	*	D23-0297-08	BEARING METAL A		
334	1C	*	D23-0298-08	BEARING METAL B		
335	1C	*	D23-0299-08	BEARING METAL D		
336	2B	*	D23-0300-08	BEARING METAL C		
340	1C	*	E31-7731-08	MOTOR WIRE		
341	1B	*	E35-0643-08	SOLENOID CONNECTING WIRE		B
342	1B	*	E35-0644-08	MECHA CONTROL CONNECTING WIRE		
342	1B	*	E35-0646-08	MECHA CONTROL CONNECTING WIRE		A
344	2C	*	E40-4688-08	HOLDER		B
344	2C	*	E40-4689-08	HOLDER		A
346	2A	*	G01-3587-08	HEAD FLAME SPRING		
347	2A	*	G01-3588-08	HEAD LEVER SPRING		
348	2A	*	G01-3589-08	HEAD CHASSIS SPRING		
349	2A	*	G01-3590-08	REEL SPRING	L	
350	2A	*	G01-3591-08	PINCH ROLLER SPRING	L	
351	2A	*	G01-3592-08	PINCH ROLLER SPRING	L	
352	2A	*	G01-3593-08	TORSION COIL SPRING		
353	2B	*	G01-3594-08	REEL SPRING	R	
354	2B	*	G01-3595-08	PINCH ROLLER SPRING	R	
355	2B	*	G01-3596-08	PINCH ROLLER SPRING	R	
356	1B	*	G01-3597-08	REVERS ARM SPRING		
357	2B	*	G01-3598-08	FLYWHEEL SPRING	L	
358	2B	*	G01-3599-08	FLYWHEEL SPRING	R	
359	1B	*	G01-3600-08	EJECT LEVER SPRING		B
359	2C	*	G01-3601-08	EJECT LEVER SPRING		A
362	2A	*	G02-1027-08	AZIMUTH SPRING		
363	1A	*	G02-1028-08	CASSETTE SPRING		
365	2A	*	J19-3592-08	HEAD HOLDER ASSY		B
365	2A	*	J19-3594-08	HEAD HOLDER ASSY		A
366	1B	*	J19-3593-08	LEAD HOLDER		
368	1C	*	J21-6020-08	FW BRACKET		
370	1B, 2C	*	J31-0861-08	EJECT COLLER		

L:Scandinavia

K:USA

P:Canada

Y:PX(Far East, Hawaii)

T:England

E:Europe

Y:AAFES(Europe)

X:Australia

M:Other Areas

A : A DECK

B : B DECK

△ indicates safety critical components.

KX-W893

PARTS LIST

× New Parts

Parts without Parts No. are not supplied.

Les articles non mentionnes dans le Parts No. ne sont pas fournis.

Teile ohne Parts No. werden nicht geliefert.

Ref. No. 参照番号	Address 位置	New Parts 新	Parts No. 部品番号	Description 部品名 / 規格	Desti- nation 仕 向	Re- marks 備考
372	1C	*	J39-0178-08	SPACER		
374	1B	*	J70-0442-08	PRINTED WIRING BOARD		
375	2C	*	J70-0443-08	PRINTED WIRING BOARD		
378	2A	*	N09-3011-08	SCREW		
379	2A	*	N09-3012-08	SCREW		
380	2A	*	N09-3013-08	SCREW		
381	1A, 2C	*	N09-2789-08	SCREW		
382	1C	*	N09-3015-08	SCREW		
383	1C	*	N09-3016-08	SCREW		
384	1C	*	N09-3017-08	SCREW		
385	1B, 2C	*	N09-3018-08	SCREW		
386	1A	*	N09-3019-08	HEAD SCREW		
388	1B	*	N19-1334-08	WASHER		
389	2B, 1C	*	N19-1335-08	WASHER		
390	1B	*	N19-1338-08	HEAD WASHER		
391	1B	*	S74-0020-08	LEAF SWITCH		
393	1B	*	S90-0115-08	MODE SWITCH		
395	1B	*	T94-0231-08	SOLENOID ASSY		
396	1C	*	T95-0129-08	HALL IC		
BM	1C	*	D16-0350-08	MAIN BELT		
BR	1B	*	D16-0349-08	REEL BELT		
PF	2B	*	D14-0350-08	PINCH ROLLER ASSY		
PR	2A	*	D14-0349-08	PINCH ROLLER ASSY		
MM	1C	*	T42-0639-08	DC MOTOR ASSY		
PH	2A	*	T31-0066-08	PLAY HEAD		A
RPEH	2A	*	T39-0020-08	RECODE/PLAY/ERASE HEAD		B

L:Scandinavia

K:USA

P:Canada

Y:PX(Far East, Hawaii)

T:England

E:Europe

A : A DECK

Y:AAFES(Europe)

X:Australia

M:Other Areas

B : B DECK

▲ indicates safety critical components.

KX-W893

SPECIFICATIONS

Track System	4 track, 2 channel stereo	
Recording System	AC bias (Frequency: 105 kHz)	
Heads	A DECK	
	Playback head	1
	B DECK	
	Playback/recording heads ...	1
	Erasing head	1
Motors	A DECK	DC motor × 1
	B DECK	DC motor × 1
Wow and Flutter	±0.18% (IEC)	
	±0.3% (DIN)	
	0.09% (W.RMS)	
Fast Winding Time	Approx. 115 seconds (C-60 tape)	
Frequency Response		
Normal Tape	25 Hz to 16,000 Hz, ±3 dB	
CrO ₂ Tape	25 Hz to 17,000 Hz, ±3 dB	
Metal Tape	25 Hz to 18,000 Hz, ±3 dB	
Signal to Noise Ratio		
Dolby NR OFF	52 dB	
	(IEC, 250 nWb/m, Metal tape)	
Dolby NR OFF	57 dB	
Dolby B NR ON	66 dB	
Dolby C NR ON	73 dB	
	(3rd, H.D., 3%, Metal tape)	
Harmonic Distortion	Less than 3.5%	
	(at 315 Hz, 3rd H.D., 250 nWb/m Metal tape)	
Input sensitivity/Impedance		
LINE IN	122.8 mV/47 kΩ	
Output Level/Impedance		
LINE OUT	775 mV/0.9 kΩ	
Headphones	3 mW/32 Ω	

Note:

KENWOOD follows a policy of continuous advancements in development. For this reason specifications may be changed without notice.

KENWOOD follows a policy of continuous advancements in development. For this reason specifications may be changed without notice. DOLBY and the double-D symbol are trademarks of Dolby Laboratories Licensing Corporation. Noise reduction circuit made under license from Dolby Laboratories Licensing Corporation.

KENWOOD poursuit une politique de progrès constants en ce qui concerne le développement. Pour cette raison, les spécifications sont sujettes à modifications sans préavis. La marque DOLBY et le double "D" sont des marques déposées des Dolby Laboratories. Le système de réduction du bruit de fond est fabriqué sous licence des Dolby Laboratories.

KENWOOD strebt ständige Verbesserungen in der Entwicklung an. Daher bleiben Änderungen der technischen Daten jederzeit vorbehalten. DOLBY und Doppel-D-Symbol sind eingetragene Warenzeichen der Dolby Laboratories. Dolby-Rauschunterdrückung mit Lizenz der Dolby Laboratories gefertigt.

Note:

Component and circuitry are subject to modification to insure best operation under differing local conditions. This manual is based on the U.S.A. (K) standard, and provides information on regional circuit modification through use of alternate schematic diagrams, and information on regional component variations through use of parts list.

[General]

Power Consumption	18 W
Dimensions	W: 440 mm (17-5/16")
	H: 137 mm (5-3/8")
	D: 269 mm (10-9/16")
Weight (Net)	4.6 kg (10.1 lb)

KENWOOD CORPORATION

Shionogi Shibuya Building, 17-5, 2-chome Shibuya, Shibuya-ku, Tokyo 150, Japan

KENWOOD U.S.A. CORPORATION

CONSUMER ELECTRONICS GROUP

P.O. BOX 22745, 2201 East Dominguez St., Long Beach, CA 90810, U.S.A.

KENWOOD ELECTRONICS CANADA INC.

6070 Kestrel Road, Mississauga, Ontario, Canada L5T 1S8

KENWOOD ELECTRONICS LATIN AMERICA S.A.

P.O. BOX 55-2791, Piso 6 Plaza Chase, Cl. 47 y Aquilino de la Guardia, Panama,

Republic de Panama

TRIO-KENWOOD U.K. LIMITED

Kenwood House, Dwight Road, Watford, Herts, WD1 8EB, United Kingdom

KENWOOD ELECTRONICS BENELUX N.V.

Mechelsesteenweg 418 B-1930 Zaventem, Belgium

KENWOOD ELECTRONICS DEUTSCHLAND GMBH

Rembrücker Str. 15, 6056 Heusenstamm, Germany

TRIO-KENWOOD FRANCE S.A.

13 Boulevard Ney, 75018 Paris, France

KENWOOD LINEAR S.p.A.

20125, Milano-Via Arce, 50, Italy

KENWOOD ESPAÑA S.A.

Bolivia, 239-08020 Barcelona, Spain

KENWOOD ELECTRONICS AUSTRALIA PTY. LTD. (A.C.N. 001 499 074)

P.O. BOX 504, 8 Figtree Drive, Australia Centre, Homebush, N.S.W. 2140, Australia

KENWOOD & LEE ELECTRONICS, LTD.

Unit 3712-3724, Level 37 Tower 1, Metroplaza, 223 Hing Fong Road,

Kwai Fong N.T. Hong Kong

KENWOOD ELECTRONICS SINGAPORE PTE LTD

No. 1 Genting Lane #07-00, Singapore, 1334