

**KENWOOD**  
HI/FI STEREO COMPONENTS

# SERVICE MANUAL

**L-07M**



**DC POWER AMPLIFIER**

# CONTENTS

EXTERNAL VIEW .....	3
INTERNAL VIEW .....	4
DISASSEMBLY FOR REPAIR .....	5
CIRCUIT DESCRIPTION .....	8
TROUBLE SHOOTING .....	15
DESTINATIONS' PARTS LIST .....	16
PARTS LIST .....	17
ADJUSTMENT .....	19
<b>PC BOARD/SCHEMATIC</b>	
PROTECTION (X00-1890-10) .....	20
POWER SUPPLY (X00-1900-10) .....	21
POWER AMP (X07-1520-10) .....	22
POWER CONNECTION (X07-1530-10) .....	24
REVISED CIRCUIT .....	26
SEMICONDUCTOR SUBSTITUTIONS .....	26
SCHEMATIC DIAGRAM .....	27
SPECIFICATIONS .....	28

**Note:**

Product for Europe (L and T type)  
has a middle case on the heat sink.

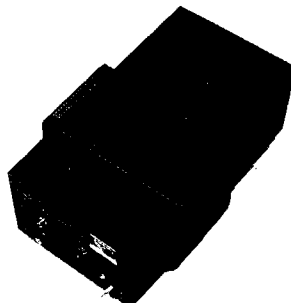

**Note:**

The products are subject to modification in components and circuits in different countries and regions. This is because each product must be used under the best condition. This manual provides information of modification based on the standard in the U.S., for the convenience of ordering associated components and parts.

U.S.A .....	K
Canada .....	P
PX .....	U
Australia .....	X
Europe .....	W
England .....	T
Scandinavia .....	L
South Africa .....	S
Other Area .....	M

# EXTERNAL VIEW

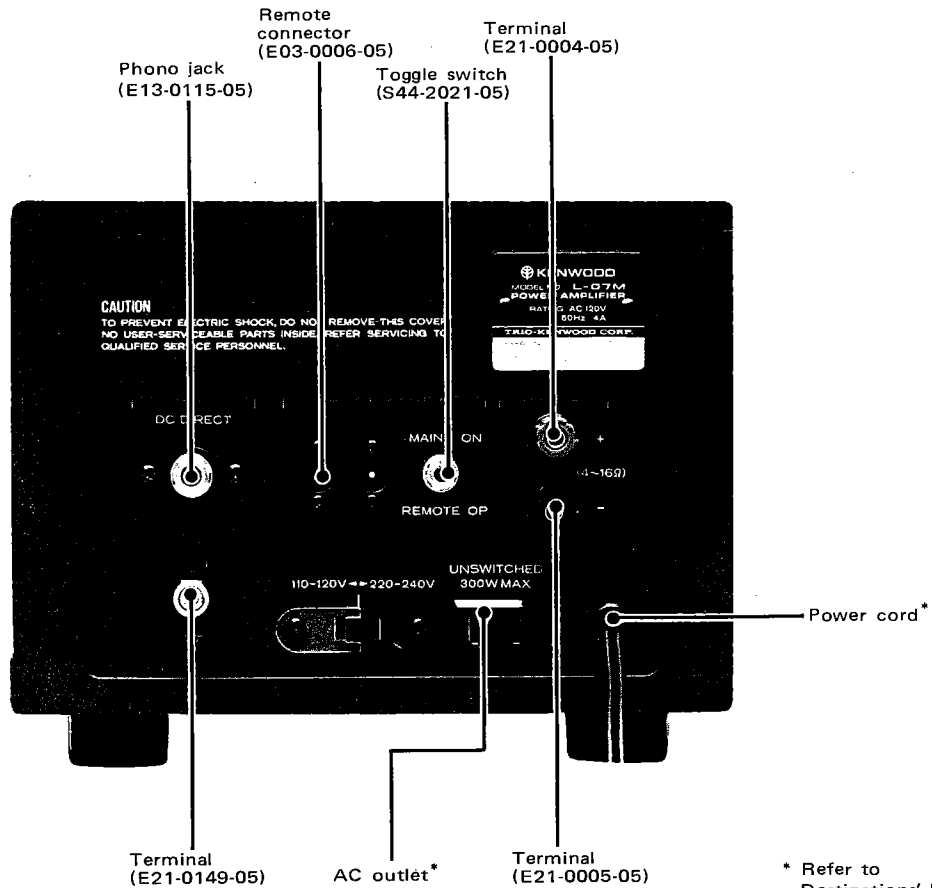
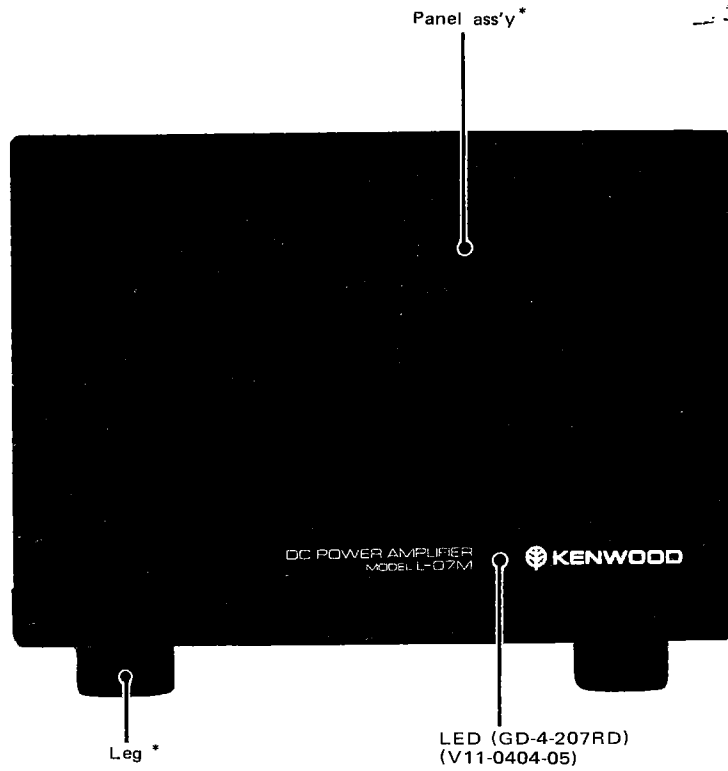

\* Refer to Destinations' Parts List.

# INTERNAL VIEW

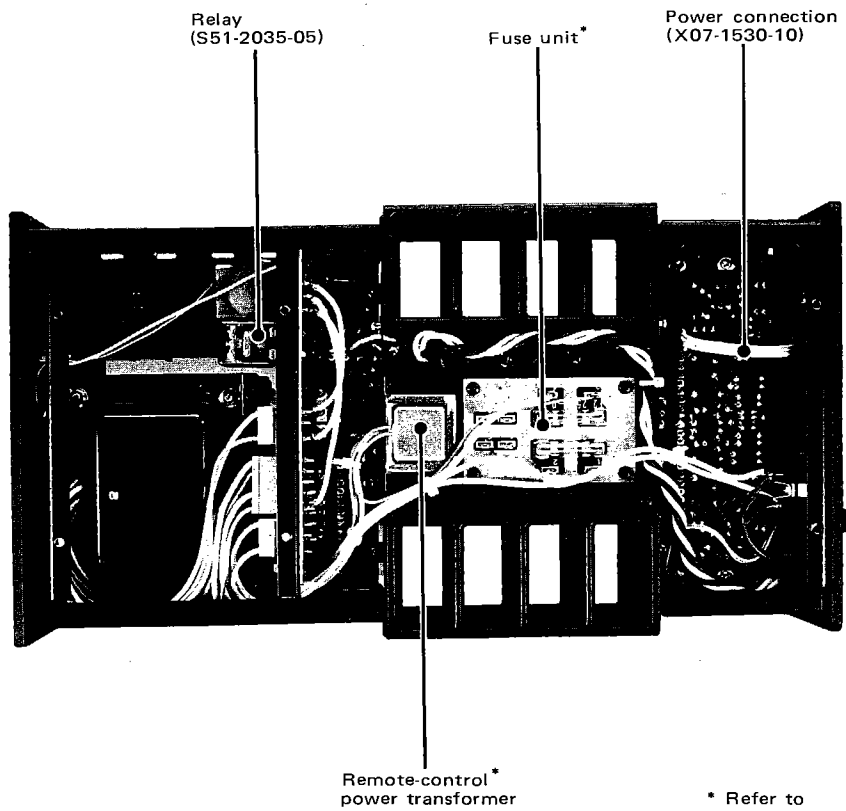
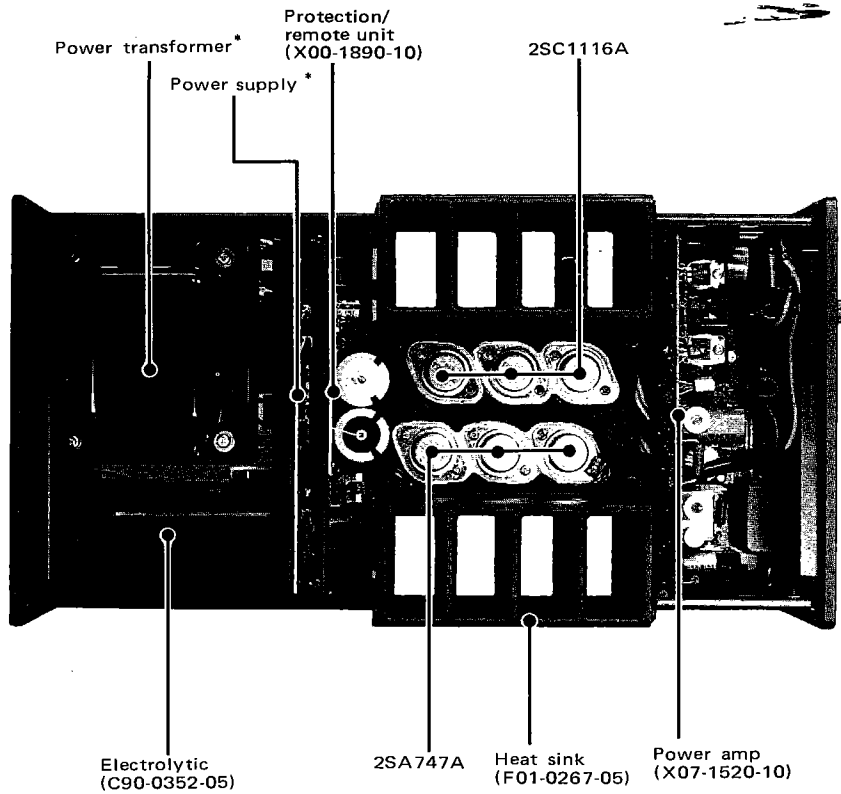

\* Refer to  
Destinations' Parts List.

# DISASSEMBLY FOR REPAIR

## CONSTRUCTION (L-07M)

The L-07M consists of the 5 essential units. The plug-in type power amplifier and protection units are connected with the power connection unit through plug connectors. The fuse unit is mounted on the reverse side of the power connection unit. The power unit with an electrolytic capacitor block is installed near the power transformer. The case cannot be dismantled unless the bottom plate is removed (Product for Europe has a middle case on the heat sink. The middle case is dismantled easily by 6 screws. Before removing the case, remove the middle case.). Each unit can be dismantled in the following manner:

### POWER SUPPLY UNIT

For checking and repairing, the power supply unit must be divided into two sections by removing the screws, with which the heat sink and the frame A are fastened. The printed circuit board can be removed from the main body in the following manner:

1. Remove the screws which fasten the printed circuit board.
2. Disconnect the soldered legs of the electrolytic capacitor block.
3. If the electrolytic capacitor is defective, remove the screws which fasten the panel assembly.
4. Remove the screws of the capacitor mounting hardware. The electrolytic capacitor block is easily dismantled if the frame A (R) is removed in advance.

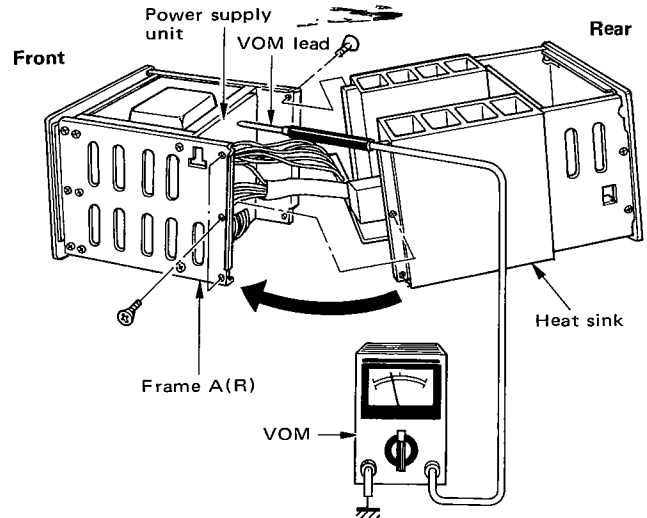

< The Way of Checking the Power Supply Unit >

### PROTECTION UNIT

For checking and repairing, the protection unit must also be divided into two sections. The printed circuit board can be removed from the main body in the following manner:

1. Remove the screws which fasten the mounting hardware of the printed circuit board.
2. Pull the circuit board upward with the mounting hardware.

**Note:**

- M3X8(F-Tap): N88-3008-45
- M3X8(Br-Tap): N87-3008-45
- M3X8: N30-3008-45

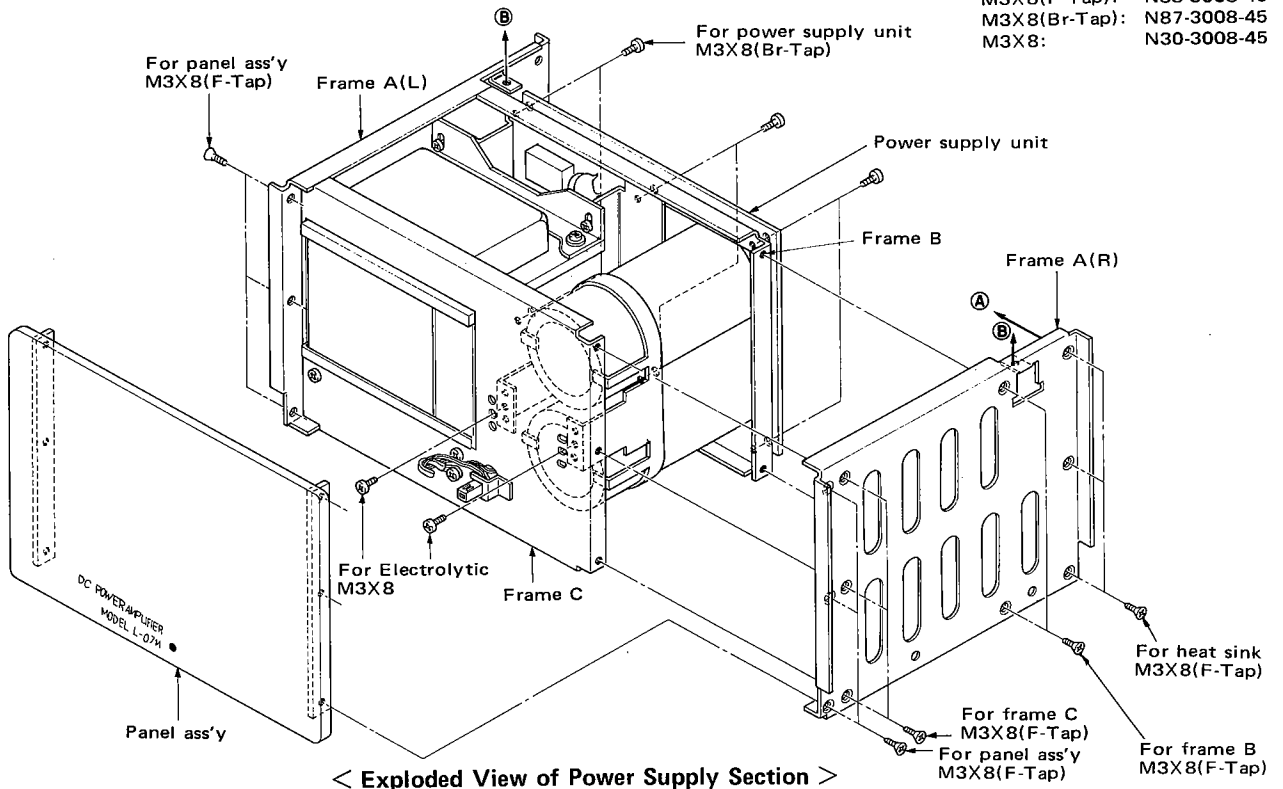

< Exploded View of Power Supply Section >

# DISASSEMBLY FOR REPAIR

**Note:**

- M3X8 (Br-Tap): N87-3008-45
- M3X8 (F-Tap): N88-3008-45
- M4X12 (Br-Tap): N87-4012-45

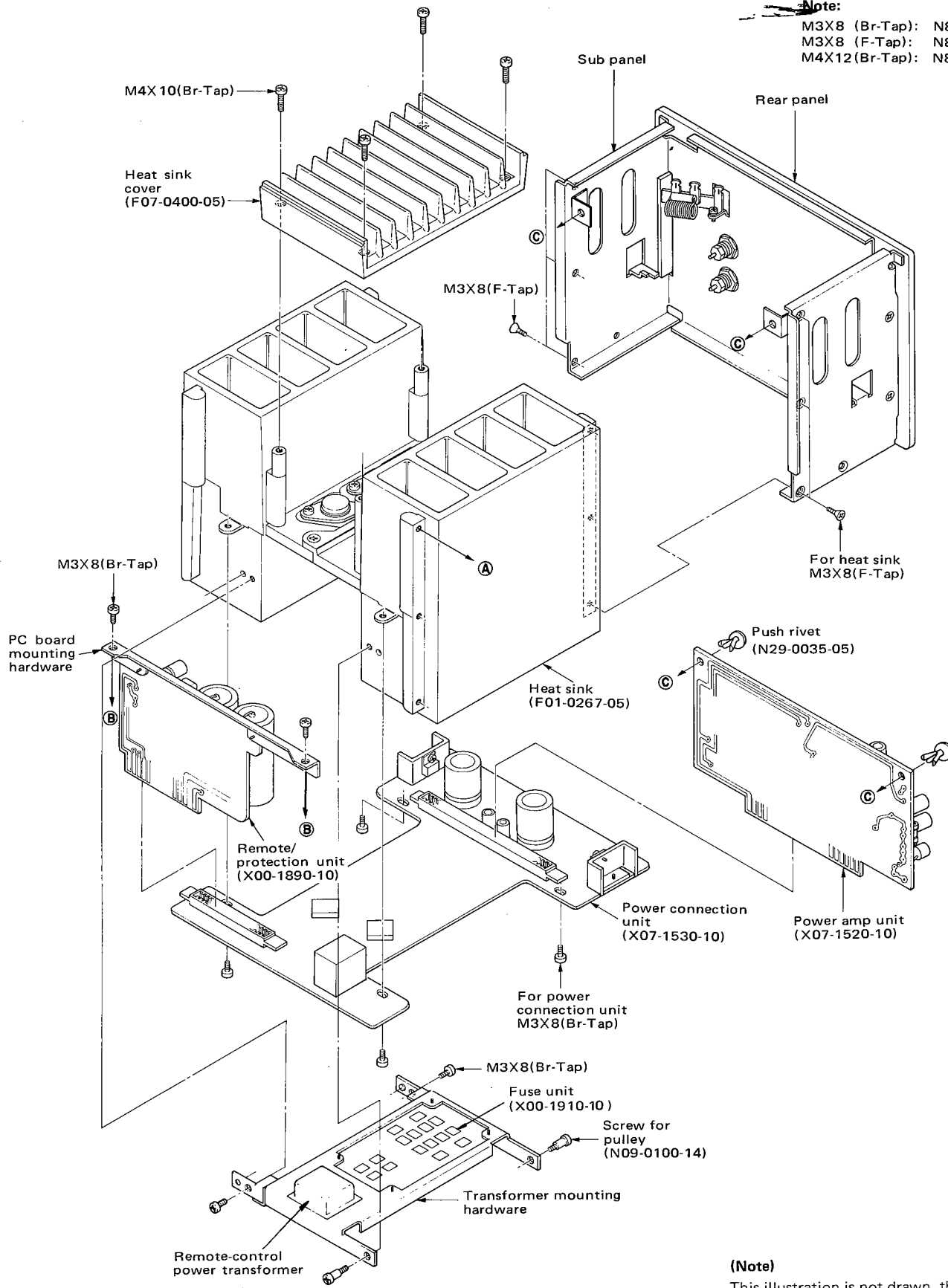

**(Note)**

This illustration is not drawn the bottom plate and the cases.

## DISASSEMBLY FOR REPAIR

### FUSE UNIT

The fuse unit is mounted on the heat sink bottom through the mounting hardware in common with the remote-control power transformer. The printed circuit board can be dismantled from the main body by removing the mounting screws.

### POWER CONNECTION UNIT (X07-1530-10)

The power connection unit is mounted on the heat sink bottom. The printed circuit board must be carefully dismantled since it is connected with the protection and power amplifier units through plug connectors.

The following arrangements are required before checking and repairing:

1. Remove the fuse unit mounting hardware from the heat sink.
2. Check the fuse unit without making it contact with other things.  
Dismantle the unit from the main body.
3. Remove the power transistor and the varistor.
4. Remove the screws which fasten the circuit board to the heat sink.

### POWER AMPLIFIER UNIT (X07-1520-10)

The power amplifier unit is connected with the power connection unit through plug connectors.

To check and repair the power unit:

1. Remove the screws which fasten the sub-panel.
2. Tilt the rear panel so that the printed circuit board can be checked easily.

**Note:**

The rear panel has the power output terminals. Handle the circuit carefully to prevent short-circuiting or shock hazard. To dismantle the printed circuit board from the main body:

3. Remove the push rivets.
4. Pull the circuit board upward.

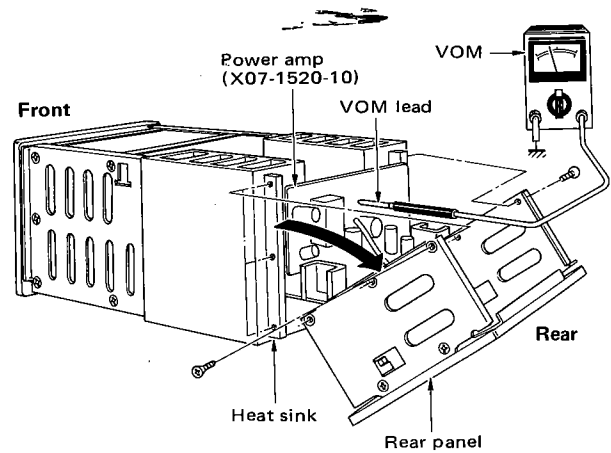

< The Way of Checking the Power Amp Unit >

### POWER TRANSISTORS

Power transistors can be checked and replaced by dismantling the heat sink cover. **If the power transistors have been replaced, adjustments are required for the bias current. The PNP and NPN transistors must be set correctly.**

### Supplied Cord

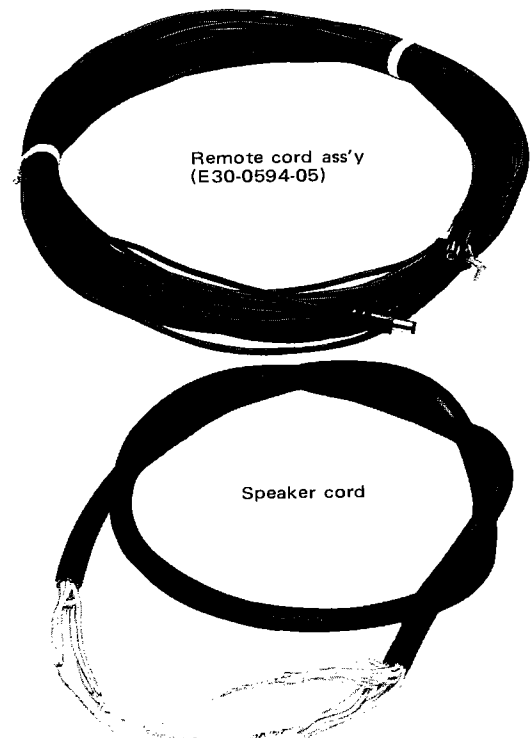

# CIRCUIT DESCRIPTION

## INTRODUCTION TO L-07M

L-07M is a DC power amplifier designed for use in combination with the control amplifier, L-07C. It is said strictly that the quality of sound is much influenced by the material and length of a cord used to connect the amplifier and the speaker system together. This is verified by the fact that exclusive speaker cords are widely sold on the market. In order to avoid this influence, the material and length of the connecting cord have been carefully analyzed for L-07M so that the output from L-07C can fully be amplified to drive the speaker systems. In other words, L-07M is designed to operate in the vicinity of the speaker systems. L-07M offers its full ability in this usage.

## CIRCUIT CONFIGURATION

The block diagram is shown below. The input stage employs a cascode connection by FET and a differential amplifier of the newly developed junction type dual FET,  $\mu$ PA-63H. The emitter circuit of the differential amplifier employs a constant-current circuit to raise the CMRR (Common Mode Rejection Ratio) value. The 3-stage differential configuration is for the improvement of circuit stability. The third differential stage is a semi-differential circuit for converting the differential output into the single mode. The complementary stage is of a 3-stage Darlington connection to increase the  $h_{fe}$  value, thus relieving the overload of semi-differential and constant-current circuits. The negative feedback is given from the two points; the mid-point of the final stage and the speaker terminal. Compared with conventional types, the negative feedback (NF) loops are enlarged to reduce the influence from the section which NF loops don't include with under one point NF. In addition, the ASO (Area of Safety Operation) circuit and the DC protection circuit are installed. There is a remote circuit so that the unit can be switched on and off remotely.

## OCL CIRCUIT AND DIFFERENTIAL AMPLIFIER

The amplifier for the OCL (Output Capacitor Less) circuit employs a differential amplifier configuration in its input stage. This is because the differential amplifier has the following outstanding features, as compared with ordinary common emitter amplifiers:

1. The frequency band is wide. In particular, the low-frequency region can be expanded to DC.
2. Drift is minimal.
3. The noise characteristic is excellent. Noise is canceled in the balanced input.
4. Design for negative feedbacks is easily achieved.

The basic circuit of the differential amplifier is shown below. The differential amplifier is composed of the two FET's or transistors which are the amplifying elements with the same characteristics. The input is applied to both bases and the output is taken out of both collectors. The differential amplifier is generally driven by positive and negative power supplies. Such a method is useful in reducing the output terminal voltage to zero, thus making an OCL (Output Capacitor Less) feature.

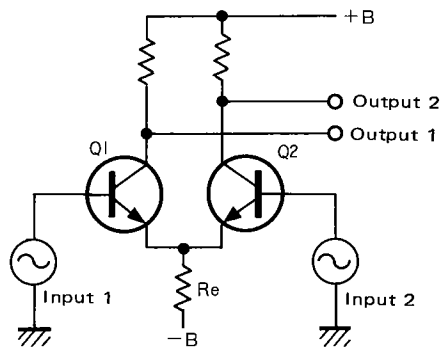

< Differential Amplifier >

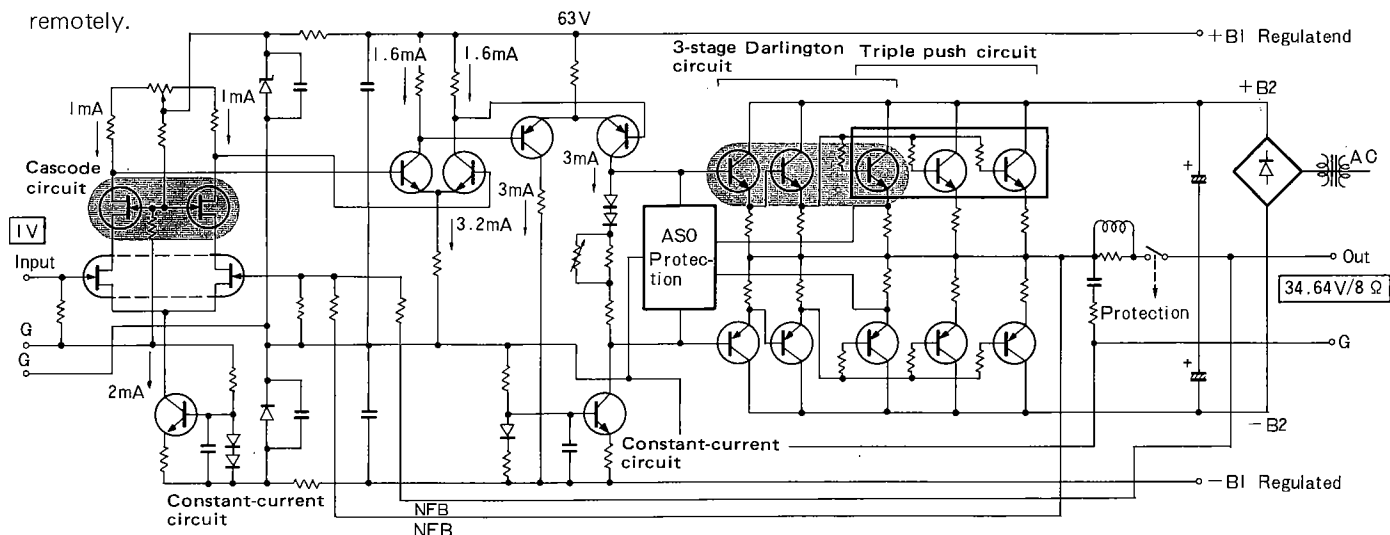

< Block Diagram of L-07M >



## CIRCUIT DESCRIPTION

If Q1 and Q2 are completely identical with each other, the output being proportional to difference of input level is generated at the output terminal as described previously. When the same potential in the in-phase is applied to input 1 and input 2 respectively, no output is generated between output 1 and output 2. This is because the emitter resistor  $R_e$  acts as a large negative feedback for both transistors. In other words, the output does not come out since both inputs mutually function to cancel the collector currents.

When the inputs are mutually in the anti-phase, the signal component does not flow through the emitter resistance and the negative feedback disappears. Thus the emitter resistance does not permit the flow of AC component. Since there is no feedback, the gain is increased by the amount of feedback reduction. In this manner, when  $R_e$  increases, its self-bias characteristic is emphasized and the negative feedback is increased. This state is equivalent to the fact that the emitter resistance  $R_e$  is zero in terms of AC component. If this resistance is increased, the common-mode component can be distinguished from the differential-mode component more effectively, thus obtaining a large CMRR value.

The value CMRR (Common Mode Rejection Ratio) is an index which indicates the quality of differential amplifier. The differential amplifier provides a so-called differential-mode gain and a common-mode gain.

The former is the result of amplified differential component between input signals, while the latter is that of suppression of the common-mode input signal. If the ratio of the former value to the latter one is defined, it can be used as an index for expressing the quality of differential amplifier since it inevitably indicates the rate of the differential-mode signal that can be taken out without influenced by the common-mode signal.

The CMRR is defined as follows:

$$\text{Differential-mode gain (DMG)} = \left( \frac{V_{out1} - V_{out2}}{V_{in1} - V_{in2}} \right) \quad V_{in1} = V_{in2}$$

$$\text{Common-mode gain (CMG)} = \left( \frac{V_{out1} + V_{out2}}{V_{in1} + V_{in2}} \right) \quad V_{in1} = V_{in2}$$

$$\text{CMRR} = \frac{\text{DMG}}{\text{CMG}}$$

The larger this value is, the more the differential signal only can be amplified. It is already described that the CMRR value is improved by the negative feedback effect of the emitter resistance. In the field of audio equipment design, the above differential amplifier is not used immediately, but a semi-differential circuit is adopted.

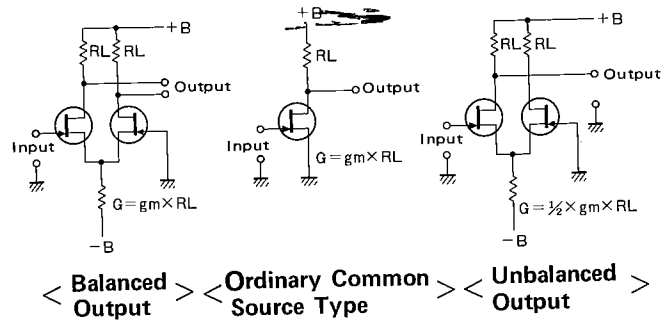

## ICL DIFFERENTIAL AMPLIFIER

When a bipolar transistor is used in the input stage of the differential amplifier, bias current must be fed to the input circuit since the transistor is a current amplifying element. Therefore a coupling capacitor must be installed. However, in the case of FET, it is an element of voltage-current amplification type. If a bias voltage is determined carefully, the input coupling capacitor can be eliminated by reducing the gate potential in bias circuit to zero. When the input coupling capacitor can be eliminated, the phase, distortion and transient characteristics are extensively improved.

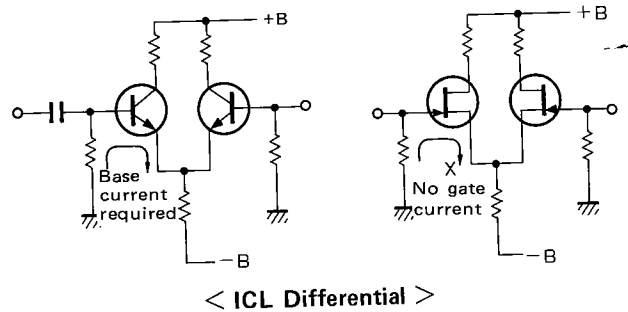

## $\mu$ PA 63H

The parameters such as  $I_D$  and  $V_{GS}$  are subjected to change with temperature. If these parameters used in the differential amplifier do not have thermally unified characteristics, the characteristic difference is directly amplified in the form of output difference. The newly developed  $\mu$ PA63H is a dual FET molded into a single chip. It is excellent in terms of characteristic dispersion.

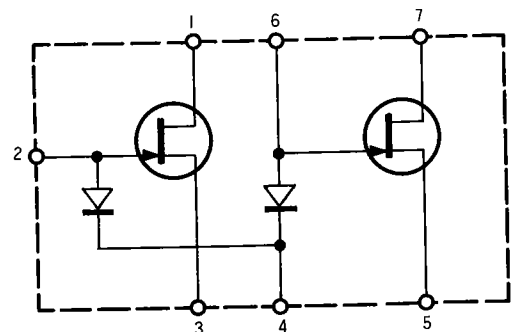

< Fig. 5  $\mu$ PA-63H Interior >

## CIRCUIT DESCRIPTION

### CASCODE CIRCUIT

The typical diagram of the cascode circuit is as shown below:

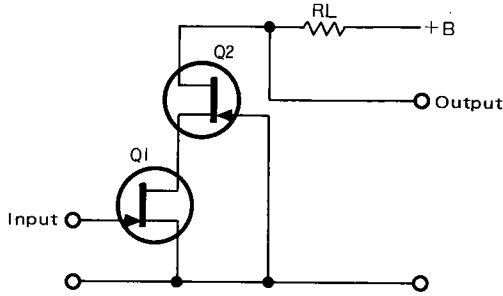

	Input impedance	Voltage gain	Output impedance
Q2 : Common gate	Medium	High	Medium
Q1 : Common source	Low	Medium	High

< Cascode >

The cascode connection presents the following two features:

- 1 Gate leakage current ( $I_{GSS}$ ) can be reduced.
- 2 Feedback capacitance ( $C_{rss}$ ) can be reduced.

Current can be effectively interrupted if a negative bias is applied to the P-N junction. However, the number of carriers in each region is increased by the effect of heat (temperature). Namely, the number of electrons increases in P and that of holes increases in N. If bias potential is raised further, carriers are accelerated to pass through the potential barrier of the junction plane, and the movements of carriers appear in the form of leakage current.

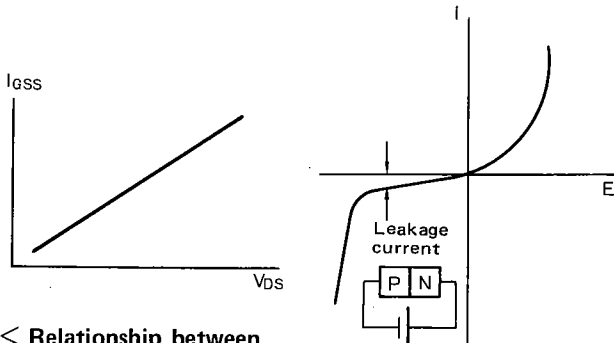

< Relationship between Source-Drain Voltage & Gate Leakage Current >

< I-E Characteristic of P-N Junction >

In the L-07M unit, the input stage employs an FET to compose a DC amplifier. However, the drain voltage ( $V_D$ ) of the input stage cannot be lowered since the second-stage differential amplifier is designed to operate between +B and GND potential. Namely,  $I_{GSS}$  increases if  $V_{DS}$  is raised and then the dynamic range of the next-stage differential amplifier is lowered if a high resistance is used to lower the value of  $V_{DS}$ . In the worst case, such a condition may give rise to an output clipping. For this reason the cascode connection is adopted to lower  $V_{DS}$  so that the load can not be effective in terms of AC.

If a resistance load is simply adopted in the common source circuit,  $V_{DS}$  changes in compliance with the input signal. If  $V_{DS}$  varies widely,  $C_{rss}$  increases as illustrated below. However, in the cascode circuit the gate potential of Q2 is fixed and the amount of variation in  $V_D$  of Q1 is lower than that when a resistance load is adopted. Thus  $V_{DS}$  is kept almost constant to reduce  $C_{rss}$  variation as low as possible.

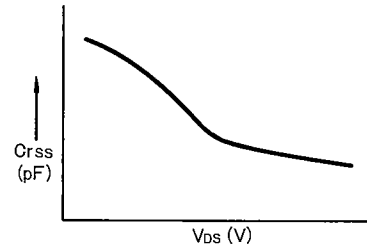

< Relationship between  $C_{rss}$  and  $V_{DS}$  >

### CONSTANT-CURRENT CIRCUIT

In the FET amplifier, the amplifier gain is expressed by the product of  $g_m$  and  $R_L$ . To obtain a higher gain,  $g_m$  or  $R_L$  may be increased. However, the FET generally possesses a considerably low  $g_m$  and it is impossible to increase the  $g_m$  value extremely. On the other hand a considerable amount of current must be supplied to increase the  $R_L$  value. Thus a high source voltage must be applied to an FET which possesses insufficient  $g_m$ . As a result there will be a problem of FET withstand voltage. For this reason, a constant-current circuit is employed.

This circuit is devised to maintain a constant emitter-base voltage ( $V_{BE}$ ) and a constant  $I_B$ , thus maintaining a constant  $I_C$  value as a result. As is recognized from the static characteristics of the transistor, the  $V_{BE}-I_B$  characteristic is expressed by a single curve (diode characteristic) at a constant temperature. If  $V_{BE}$  is maintained constant,  $I_B$  is also maintained constant.

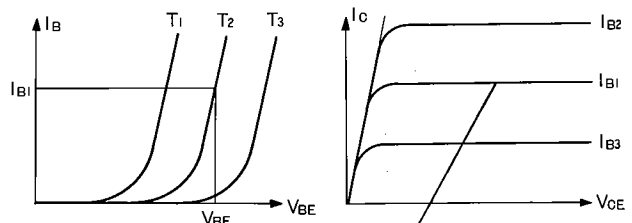

<  $V_{BE}-I_B$  Characteristics >

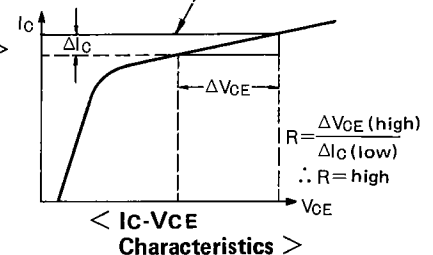

<  $I_C-V_{CE}$  Characteristics >

## CIRCUIT DESCRIPTION

The VCE-IC characteristics are based on the parameter IB. When IB is constant, the VCE-IC characteristics are expressed by a single curve. In a region where the VCE-IC characteristics are saturated, IC is almost constant regardless of variations in VCE. Namely the circuit assumes the constant-current characteristics. When a constant-current circuit is used on the emitter side (source side) of the differential amplifier, the CMRR value will be improved. If it is used as an amplifier load, then it functions as a light load and the current can be always constant and sufficient. With these advantages, it can be regarded as a high-impedance circuit in terms of AC.

### 3-STAGE DARLINGTON CIRCUIT

The input impedance for a standard 2-stage Darlington connection is expressed as follows:

$$R_{in} = h_{fe1} \times h_{fe2} \times R_L$$

However, since the load is a constant-current circuit in the final differential stage, the output impedance becomes high as described in the section of the constant-current circuit. Therefore, an overload occurs and distortion increases if the input impedance on the Darlington side is too low. Thus the circuit is provided with three stages to obtain a large hfe and the input impedance is increased to reduce the load of the former stage.

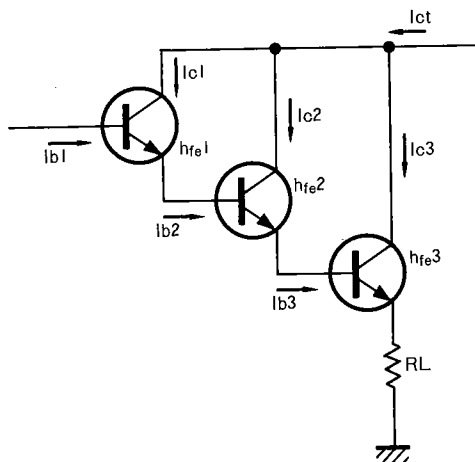

$$\begin{aligned} I_{ct} &= I_{c1} + I_{c2} + I_{c3} \\ I_{c1} &= I_{b1} \times h_{fe1} \\ I_{c2} &= I_{b2} \times h_{fe2} = (I_{b1} + I_{b1} \times h_{fe1}) \times h_{fe2} \\ I_{c3} &= I_{b3} \times h_{fe3} \\ I_{b2} &= I_{b1} + I_{c1} \\ I_{b3} &= I_{b2} + I_{c2} = I_{b1} + I_{c1} + I_{c2} \\ &= I_{b1} + I_{b1} \times h_{fe1} + (I_{b1} + I_{b1} \times h_{fe1}) \times h_{fe2} \\ h_{fe} &= I_{ct} / I_{b1} \\ &= (h_{fe1} + 1)(h_{fe2} + 1)(h_{fe3} + 1) - 1 \\ h_{fe} + 1 &\approx h_{fe} \\ h_{fe} &= h_{fe1} \times h_{fe2} \times h_{fe3} \end{aligned}$$

< hfe in 3-Stage Darlington Circuit >

### OVERDRIVE LIMITER

For the output stage, the clipping point at time of excessive input is determined by the source voltage. However, in the power amplifier like L-07M, the final stage is arranged in parallel connection and trouble may occur if clipping takes place in the final stage due to characteristic dispersion in final transistors. The overdrive limiter circuit is used to cause clipping before the final stage. The limiter functions with the input of the initial driver stage. For example, if the base potential of Qe9 is extremely raised by the input signal, and when it is increased by the amount of the on-level of De15 and 16 (1.2V) which is higher than the level preset by De7, 11, and 12, then De15 and 16 are turned on and the input signal level does not increase more. The same thing can be said for the opposite potential except for the fact that the polarity is reversed. Reverse voltage of De15, 16 is 70 volts per diode. Since voltage almost identical with the source voltage is applied to the opposite diode at the clipping level, two diodes are used to obtain allowance against overvoltages.

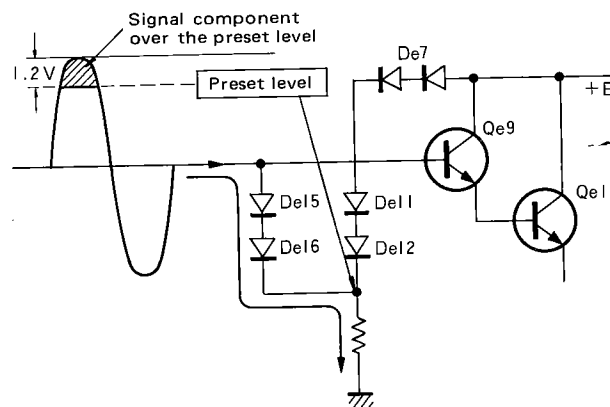

< Overdrive Limiter Function >

### ASO DETECTOR CIRCUIT

As shown in the diagram, the operational region of the transistor is limited by VCE, IC, and PC with the maximum ratings. The electrolytic capacitor Ce7 is generally charged by the positive components of the AC voltage (signal) at the output terminal through Re24 and De9. Thus the base potential of Qe15 is lowered and the detecting sensitivity is reduced. With negative components, on the other hand, Ce8 is charged through Re25 and De10 and the base potential of Qe16 is raised. Also in this case the detecting sensitivity is reduced at a large signal. In case the output terminal is short-circuited for a certain reason, Ce7 and Ce8 are discharged and the collector current of the power transistors is detected by the emitter resistor. The resultant voltage drop is divided and applied to the bases of Qe15 and Qe16. This is the function of the ASO circuit.

# CIRCUIT DESCRIPTION

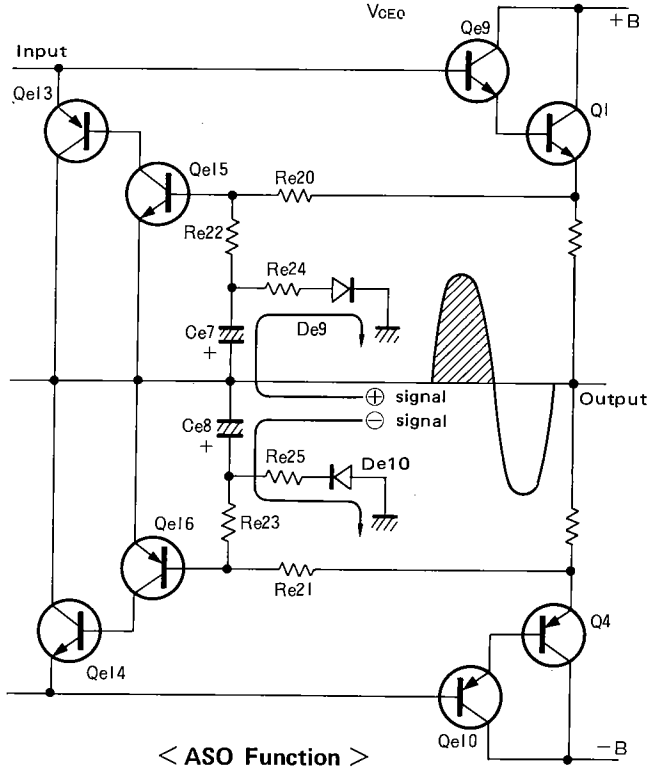
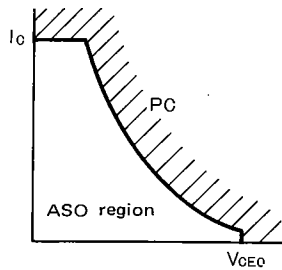

< ASO Function >

## DC PROTECTION

DC potential is always maintained at zero volt at the output terminal by the use of two power sources and differential amplifier stages. If this potential widely deviates for a certain reason, the differential amplifier itself cannot reduce such a deviation to zero volt. Thus unreasonable voltage may be applied to the speaker as a load and the

speaker may be destroyed. The DC protection circuit is operated when DC voltage occurs at output terminal and the differential amplifier cannot dispose of it. This circuit is provided with a relay which disconnects the load to protect it against such abnormality.

If a DC voltage is generated and cannot be compensated by the differential amplifier, Ck3 is charged through Rk5. When positively charged, the base potential of Qk5 is raised, which is therefore turned on. When negatively charged, the base potential of Qk4 is lowered, which is then turned on. While Qk4 and Qk5 are in the OFF state, the base potential of Qk6 is about  $-12V$  through Rk7, 11, and then Qk6 is turned off. If Qk4 or Qk5 is turned on due to circuit abnormality, the base potential of Qk6 is raised and it is turned on. Then Rk10 and Rk12 are connected in parallel and Qk6 is turned on since its base potential is raised. When Qk4 turned on, it lowers its collector potential to the GND level (0V). Also in this case Qk6 is turned on since its base potential is raised at that time. Qk7 and Qk8 compose a Darlington circuit and is provided with a relay as a load. Normally (when a drift from the center voltage is small), Qk6 is in the OFF state and the base of Qk7 is applied with a voltage which is divided by resistors Rk13, 15, 16. Thus Qk7 remains to be turned on and holds the relay. However, when Qk6 is turned on, it permits the flow of collector current and the base potential of Qk7 is lowered. Qk7 is then turned off and the relay is released. Thus the relay disconnects the output circuit to prevent the load from being applied with DC. The bases of Qk7 and Qk8 in the Darlington circuit are connected with Ck4. This capacitor is used to suppress the shock noise which is usually generated when the POWER switch is turned on. Namely when the power is supplied, the base potential of Qk7 gradually rises in compliance with the time constant of Ck4 and Rk13. When Ck4 has been charged up, Qk7 is turned on and the relay is actuated. Since this time is longer than the period required for the stabilization of circuit after switching-on at the POWER switch, the shock noise cannot be heard actually.

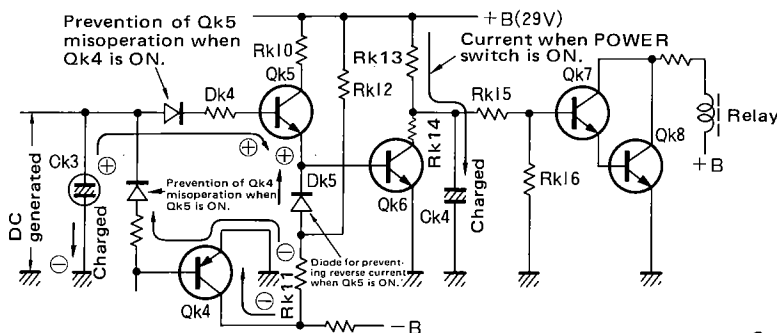

- ⊕ When DC potential is positively drifted
- ⊖ When DC potential is negatively drifted

< Function of DC Protection Circuit >

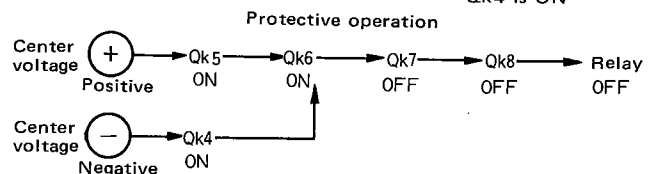
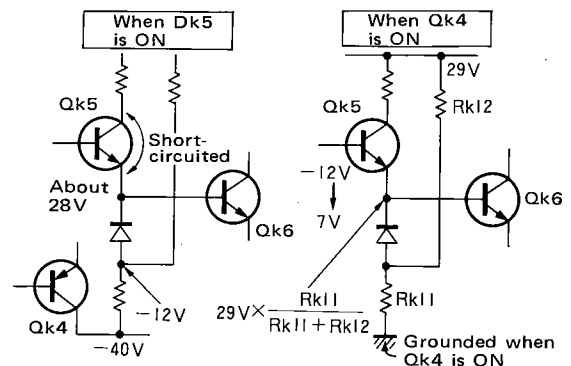

# CIRCUIT DESCRIPTION

## REMOTE CIRCUIT

As described previously, the power amplifier L-07M is generally located near the speaker system. Then there is much distance between the power amplifier and the control amplifier, L-07C, and switching on and off the L-07M unit is very troublesome. Hence this remote circuit is devised. The remote circuit enables the L-07M unit to be switched on and off through a remote cord simultaneously when the L-07C unit is switched on and off. The circuit diagram of the remote circuit is shown below.

When S1 (or the reed relay of L-07C) is open, voltage is applied to the base of Qk2, which is therefore turned on. Then Qk3 is turned off since collector potential of Qk2 is lowered and the power relay is released. The power relay has the same function as for the power switch. In other words, the release of the power relay is equivalent to the switching off of the power switch.

When S1 (or the reed relay) is short-circuited, Qk2 is turned off since its base potential is lost. When Qk2 is OFF, the collector potential of Qk2 is raised and Qk3 is turned on. Thus the power relay operates and the power switch is ON to supply power to the power amplifier. As is obvious from the circuit diagram, this remote circuit functions merely by the insertion of the power plug into the wall outlet regardless of whether the POWER switch is turned on or off.

## POWER SUPPLY CIRCUIT

The differential stages of L-07M employs a constant-voltage (regulated) power supply, while the final stage works on a separate power supply. This arrangement is aimed to eliminate mutual interference between former stages and the final stage. The power supply for the differential stages is a feedback type regulated power circuit, the principle of which is shown in the diagram. Variations in the output voltage are picked up through the feedback loop circuit to actuate the control element. Thus variations in the output voltage are suppressed to a minimum automatically.

The feedback regulator circuit in this unit is an OP amp (operating amplifier), IC RC4558T. The zener diode for generating a reference voltage is carefully selected so that it can eliminate the thermal drift almost completely even at a room temperature. The operational amplifier IC may be destroyed if the difference is enlarged between feedback input voltage and reference voltage. Therefore, it is protected by the diodes (Df3~6).

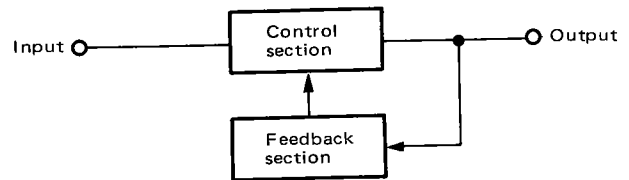

< Block Diagram of Feedback Type Stabilized Source >

The following diagram shows the power circuit for this unit. The operation of the feedback regulator circuit is as follows: The output voltage is generally divided by Rf17, 21 and VRf1, and the divided voltage is applied to the operational amplifier. The applied voltage is compared with the reference voltage, and the differential output voltage is applied to the base of Qf3. The voltage applied to Qf3 is used to control the base potential of Qf1.

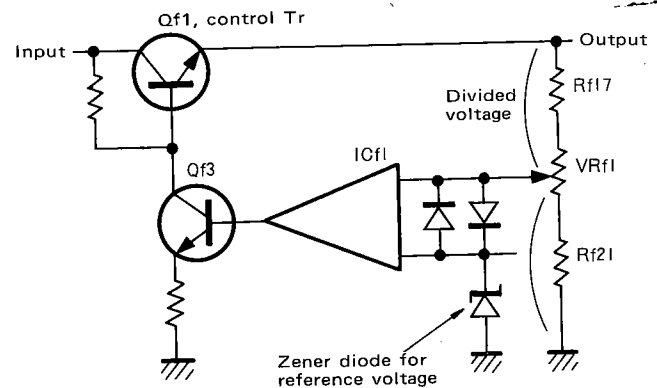

< Principle of Operation >

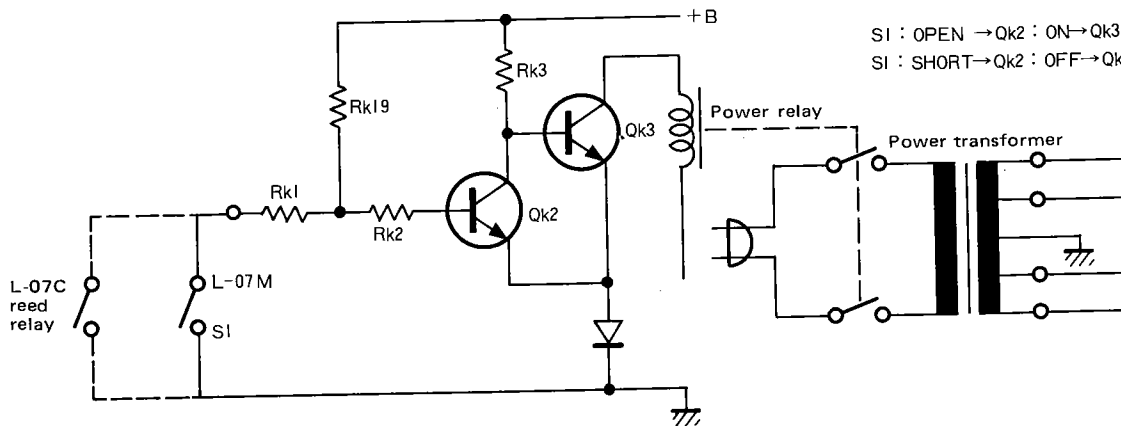

S1 : OPEN → Qk2 : ON → Qk3 : OFF → Power relay : OFF  
 S1 : SHORT → Qk2 : OFF → Qk3 : ON → Power relay : ON

< Remote Circuit Diagram >

## CIRCUIT DESCRIPTION

If the output terminal of the regulated power supply is short-circuited or overloading occurs, the control transistor, Qf1 may be destroyed. Therefore this control transistor requires a protection circuit. The protection circuit comes in current limiting type and current cut-off type. The former type is used in this unit and Qf5 is the transistor used for this purpose.

When an overcurrent flows, the voltage drop at Rf11 is increased and the base potential of Qf5 is raised. Thus Qf5 is turned on. Since the collector of Qf5 is connected with the base of Qf1, the base current of Qf1 flows into Qf5 when Qf5 is turned on. This current flow is used to protect Qf1 against the attack of overcurrent.

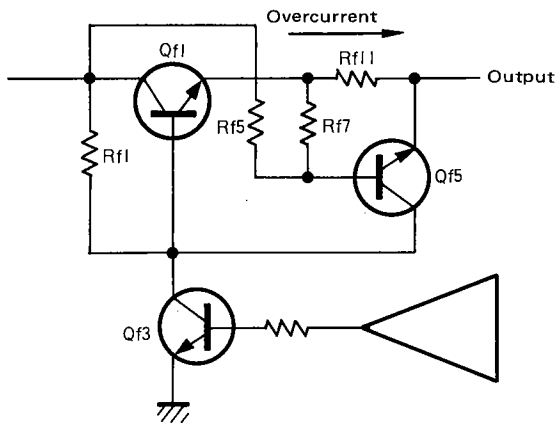

< Protection Circuit Diagram >

If the output terminal is short-circuited, the emitter potential of Qf1 is lowered to the GND level (0V) and thus the value VCE becomes larger than usual. The short-circuiting also raises the base potential of Qf5, which is therefore turned on. As is performed for the overcurrent, the base current of Qf1 is controlled to protect Qf1. The above descriptions are for operations in positive circuit. Operations in negative circuit are the same except that the polarity is reversed.

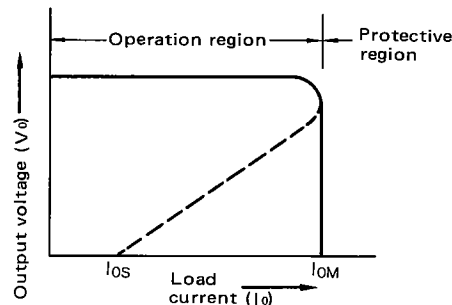

< Characteristics of Protection Circuit >

# TROUBLESHOOTING

Checking the unit, refer to disassembly for repair on page 5.

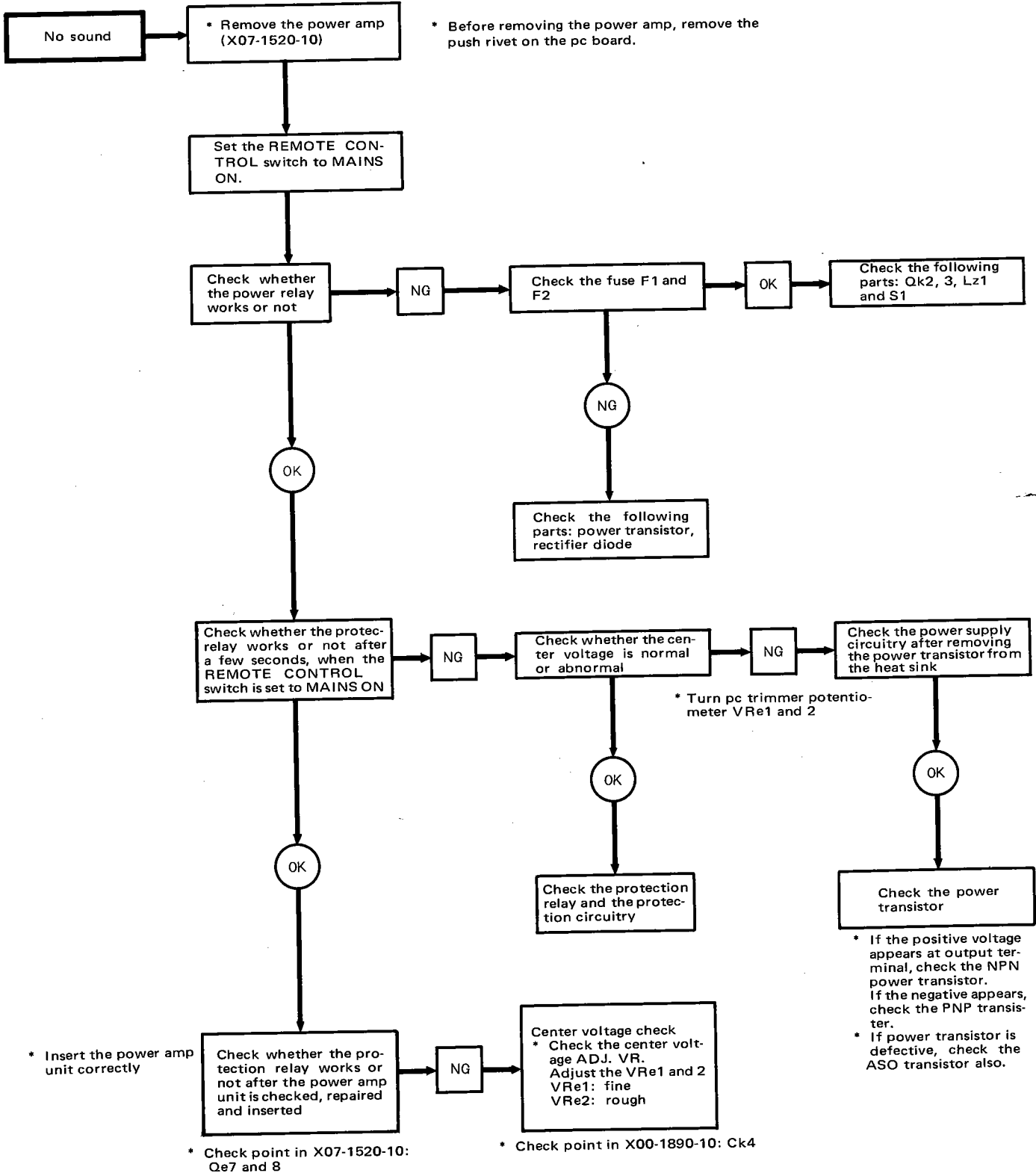

## DESTINATIONS' PARTS LIST

Ref. No.	U.S.A. (K)	Canada (P)	PX (U)	Australia (X)	Europe (W)	Scandinavia (L)	England (T)	South Africa (S)	Other Area (M)	Description
-	-	-	-	-	-	A01-0323-02	A01-0323-02	-	-	Middle case ☆
-	A20-1139-13	A20-1139-13	-	-	A20-1139-13	A20-1139-13	A20-1142-13	-	A20-1139-13	Front panel ☆
-	A23-0758-03	A23-0777-03	-	-	A23-0758-03	A23-0758-03	A23-0758-03	-	A23-0758-03	Rear panel ☆
-	B46-0061-10	B46-0055-20	-	-	-	-	B46-0060-10	-	-	Warranty card
-	B50-1612-00	B50-1613-00	-	-	B50-1612-00	B50-1612-00	B50-1614-00	-	B50-1612-00	Instruction manual ☆
-	-	-	-	-	D32-0081-04	-	-	-	D32-0081-04	Switch stopper (Power voltage selector) ☆
-	E08-0225-05	E08-0225-05	-	-	-	-	-	-	E08-0225-05	AC outlet
-	E30-0600-05	E30-0595-15	-	-	E30-0595-15	E30-0595-15	E30-0595-15	-	E30-0595-15	Speaker cord ☆
-	E30-0181-05	E30-0181-05	-	-	E30-0580-05	E30-0292-05	040-0306-05	-	E30-0515-05	Power cord
-	E31-0074-05	E31-0074-05	-	-	E31-0096-05	E31-0096-05	E31-0096-05	-	E31-0074-05	Lead with connector ☆
-	-	-	-	-	E31-0075-05	-	-	-	E31-0075-05	Lead with connector ☆
-	-	-	-	-	F05-5024-05	-	-	-	F05-5022-05	Spare fuse (5A)
-	H01-1699-04	H01-1701-04	-	-	H01-1699-04	H01-1699-04	H01-1700-04	-	H01-1699-04	Carton case ☆
-	-	H03-0566-04	-	-	-	-	-	-	-	Carton case (Out side) ☆
-	H20-0441-04	H20-0441-04	-	-	H20-0441-04	H20-0441-04	H20-0441-04	-	H20-0417-04	Polyethylene cover
-	J02-0073-04	J02-0049-14	-	-	J02-0049-14	J02-0049-14	J02-0049-14	-	J02-0049-14	Leg x 4
-	-	-	-	-	-	J21-1666-04	J21-1666-04	-	-	Stopping hardware X 2
-	J41-0034-05	J41-0034-05	-	-	J41-0033-05	J41-0033-05	J41-0024-05	-	J41-0033-05	Power cord bushing
-	L01-1311-05	L01-1318-05	-	-	L01-1316-05	L01-1312-05	L01-1317-05	-	L01-1315-05	Power transformer ☆
-	L01-1321-05	L01-1321-05	-	-	L01-1324-05	L01-1324-05	L01-1324-05	-	L01-1324-05	Remote-control power transformer ☆
S2	-	-	-	-	S31-3004-05	-	-	-	S31-3004-05	Slide (Power voltage selector) ☆
-	X00-1900-10	X00-1901-01	-	-	X00-1900-61	X00-1900-61	X00-1900-61	-	X00-1900-21	Power supply unit ☆
-	X00-1910-10	X00-1910-10	-	-	X00-1910-61	X00-1911-71	X00-1911-71	-	X00-1910-21	Fuse unit ☆

Note: Destinations' Parts List of the power supply and the fuse unit is written next page.



## PARTS LIST

Symbol ☆ : New parts

Ref. No.	Parts No.	Description	Re- marks
<b>CAPACITOR</b>			
C1	C90-0352-05	Electrolytic 18,000 $\mu$ F 71WV	☆
<b>RESISTOR</b>			
R1	RS14GB3D100JMA	Metal film 10 $\Omega$ $\pm$ 5% 2W	
<b>SEMICONDUCTOR</b>			
Q1~3	V03-0441-05	Transistor 2SC1116A	
Q4~6	V01-0166-05	Transistor 2SA747A	
D1	V11-0404-05	LED GD-4-207RD	
<b>COIL</b>			
L1	L39-0081-05	Phase compensation coil	
<b>SWITCH</b>			
S1	S44-2021-05	Toggle (REMOTE)	☆
<b>MISCELLANEOUS</b>			
—	A01-0316-02	Front case	☆
—	A01-0317-03	Rear case	☆
—	A40-0169-12	Bottom plate	☆
—	B59-0084-00	Booklet for L-07M and C	
—	E02-0001-05	Transistor socket x 6	
—	E03-0006-05	Remote connector x 2	
—	E13-0115-05	Phono jack (Screw type)	☆
—	E21-0004-05	1P terminal (RED)	☆
—	E21-0005-05	1P terminal (BLACK)	☆
—	E21-0149-05	Terminal	
—	E22-0309-05	Lug	
—	E29-0087-14	GND hardware	☆
—	E29-0090-04	Connecting plate	☆
—	E30-0594-05	Remote cord ass'y	☆
—	E31-0080-05	Lead with connector	☆
—	E31-0088-05	Lead with connector	☆
—	E31-0095-05	Lead with connector	☆
—	F01-0267-05	Heat sink x 2	☆
—	F07-0400-05	Heat sink cover	☆
—	F20-0066-05	Mica plate x 6	
—	H12-0059-03	Buffer fixture x 2	☆
—	J19-0306-05	Lead holder	
—	J30-0137-04	Spacer	☆
—	X00-1890-10	Protection/Remote unit	☆
—	X07-1520-10	Power amp unit	☆
—	X07-1530-10	Power connection unit	☆

## PROTECTION (X00-1890-10)

Ref. No.	Parts No.	Description	Re- marks
<b>CAPACITOR</b>			
Ck1, 2	C90-0356-05	Electrolytic 470 $\mu$ F 100WV	☆
Ck3	CE04BW1A101MEL	Non-pole electrolytic 100 $\mu$ F 10WV	
Ck4	CE04AW1E330MEL	Electrolytic 33 $\mu$ F 25WV	
<b>RESISTOR</b>			
Rk4	RC05GF2H562KKW	Carbon 5.6k $\Omega$ $\pm$ 10% 1/2W	
Rk17	RS14GB3A821JMA	Metal film 820 $\Omega$ $\pm$ 5% 1W	

Ref. No.	Parts No.	Description	Re- marks
<b>SEMICONDUCTOR</b>			
Qk2	V03-0424-05	Transistor 2SC1400(U)	
Qk3	V03-0215-05	Transistor 2SC1213A(B) or (C)	
Qk4	V01-0073-05	Transistor 2SA673A(B) or (C)	
Qk5, 6	V03-0215-05	Transistor 2SC1213A(B) or (C)	
Qk7	V03-0424-05	Transistor 2SC1400(U)	
Qk8	V03-0452-05	Transistor 2SC1735(D) or (E)	
Dk2	V11-0219-05	Diode V06B	
Dk3~5	V11-0273-05	Diode 1S2076A	
Dk6	V11-0417-05	Zener diode EQB01-28	

## POWER SUPPLY (X00-1900-10)

Ref. No.	Parts No.	Description	Re- marks
<b>CAPACITOR</b>			
Cz1, 2	CE04W1V101	Electrolytic 100 $\mu$ F 35WV	
Cz3	CE04W1J4R7	Electrolytic 4.7 $\mu$ F 63WV	☆
Cz4~9	C91-0036-05	Mylar 0.1 $\mu$ F 250WV	
Cz10	C91-0001-05	Ceramic 0.01 $\mu$ F 125WV (X00-1900-10)	
	C90-0302-15	Ceramic 0.01 $\mu$ F (X00-1900-21)	
	CK45E3D103PMU	Ceramic 0.01 $\mu$ F 2000WV (X00-1900-61)	
	C91-0025-05	film 0.01 $\mu$ F 125WV (X00-1901-01)	
<b>RESISTOR</b>			
Rz1	RS14AB3D272K	Metal film 2.7k $\Omega$ $\pm$ 10% 2W	
Rz2, 3	RS14AB3D332K	Metal film 3.3k $\Omega$ $\pm$ 10% 2W	
<b>SEMICONDUCTOR</b>			
Dz1	V11-0219-05	Diode V06B	
Dz2, 3	V11-0290-05	Diode V03C	
Dz4	V21-0018-05	Diode S25VB20	☆
Dz5, 6	V21-0019-05	Diode S1QB40	☆
<b>MISCELLANEOUS</b>			
—	E31-0077-05	Lead for connection	☆
—	E31-0078-05	Lead with connection	☆
—	E31-0079-05	Lead with connector	☆
—	E40-0342-05	Friction lock wafer (3P) x 2	☆
—	E40-0572-05	Connector (5P) x 2	☆
—	F20-0121-04	Insulator	☆
RLz1	S51-2035-05	Relay	☆

## FUSE (X00-1910-10)

Ref. No.	Parts No.	Description	Re- marks
<b>FUSE</b>			
F1	F05-5021-05	Fuse (5A) (X00-1910-10)	
	F05-2521-05	Fuse (2.5A) (X00-1910-21)	
	F05-3122-05	Fuse (3.15A) (X00-1910-61, X00-1911-71)	
F2	F05-1015-05	Fuse (0.1A) (X00-1910-10)	
	F05-1012-05	Fuse (0.1A) (X00-1910-21)	
	F05-1013-05	Fuse (0.1A) (X00-1910-61, X00-1911-71)	
—	J13-0052-05	Fuse clip x 4	

**PARTS LIST**

**POWER AMP (X07-1520-10)**

Ref. No.	Parts No.	Description	Re- marks
<b>CAPACITOR</b>			
Ce1, 2	CE04W1V101EL	Electrolytic 100 $\mu$ F 35WV	
Ce3, 4	CE04W1J471EL	Electrolytic 470 $\mu$ F 63WV	
Ce5, 6	CE04W1E100EL	Electrolytic 10 $\mu$ F 25WV	
Ce7, 8	CE04W1A470EL	Electrolytic 47 $\mu$ F 10WV	
Ce11	CC45SL1H391K	Ceramic 390pF $\pm$ 10%	
Ce13	CC45SL1H330K	Ceramic 33pF $\pm$ 10%	
Ce14	CC45SL1H121K	Ceramic 120pF $\pm$ 10%	
Ce15	CC45SL1H330K	Ceramic 33pF $\pm$ 10%	
Ce16	CK45B1H681K	Ceramic 680pF $\pm$ 10%	
Ce17	CC45SL1H040D	Ceramic 4pF $\pm$ 0.5pF	
Ce21	CQ93M1H393K	Mylar 0.039 $\mu$ F $\pm$ 10%	
<b>RESISTOR</b>			
Re30	RD14GY2E112JMA	Carbon 1.1k $\Omega$ $\pm$ 5% 1/4W	
Re31	RD14GY2E821JMA	Carbon 820 $\Omega$ $\pm$ 5% 1/4W	
Re32, 33	RD14GY2E681JMA	Carbon 680 $\Omega$ $\pm$ 5% 1/4W	
Re34, 35	RD14GY2E101JMA	Carbon 100 $\Omega$ $\pm$ 5% 1/4W	
Re40	RS14AB3D822JMA	Metal film 8.2k $\Omega$ $\pm$ 5% 2W	
Re41, 42	RS14GB3D272JMA	Metal film 2.7k $\Omega$ $\pm$ 5% 2W	
Re43	RS14AB3D822JMA	Metal film 8.2k $\Omega$ $\pm$ 5% 2W	
Re44, 45	RS14GB3D151JMA	Metal film 150 $\Omega$ $\pm$ 5% 2W	
Re46, 47	RS14GB3D682JMA	Metal film 6.8k $\Omega$ $\pm$ 5% 2W	
<b>SEMICONDUCTOR</b>			
Qe1, 2	V09-0098-05	FET 2SK68A(L) or (M)	
Qe3	V03-0366-05	Transistor 2SC1452(B) or (G)	
Qe4, 5	V03-0408-05	Transistor 2SC1222(E) or (U)	
Qe6, 7	V01-0167-05	Transistor 2SA810(B) or (G)	
Qe8	V03-0366-05	Transistor 2SC1452(B) or (G)	
Qe9	V03-0439-05	Transistor 2SC1885(R) or (S)	
Qe10	V01-0162-05	Transistor 2SA912(R) or (S)	
Qe11	V03-0468-05	Transistor 2SC1913(Q) or (R)	
Qe12	V01-0188-05	Transistor 2SA913(Q) or (R)	
Qe13	V01-0073-05	Transistor 2SA673A(B) or (C)	
Qe14, 15	V03-0215-05	Transistor 2SC1213A(B) or (C)	
Qe16	V01-0073-05	Transistor 2SA673A(B) or (C)	
ICe1	V30-0232-05	IC $\mu$ PA63H(L) or (M)	
De1, 2	V11-0417-05	Zener diode EQB01-28	
De3~5	V11-0273-05	Diode 1S2076A	
De6~8	V21-0012-05	Varistor STV-3H(Y)	
De9~18	V11-0273-05	Diode 1S2076A	
<b>POTENTIOMETER</b>			
VRe1	R12-5022-05	PC trimmer 100k $\Omega$ (B) Center voltage	
VRe2	R12-1035-05	PC trimmer 2k $\Omega$ (B) Center voltage	☆
VRe3	R12-0062-05	PC trimmer 500 $\Omega$ (B) Bias	☆
<b>MISCELLANEOUS</b>			
-	F20-0078-05	Mica plate x 2	
-	F29-0014-05	Insulating washer x 2	

**POWER CONNECTION (X07-1530-10)**

Ref. No.	Parts No.	Description	Re- marks
<b>CAPACITOR</b>			
Cf1~3	CE04W1C470EL	Electrolytic 47 $\mu$ F 16WV	
Cf4~6	CE04W1J010EL	Electrolytic 1 $\mu$ F 63WV	
Cf7, 8	CE04W1J471EL	Electrolytic 470 $\mu$ F 63WV	
Cf9	CQ93M1H104KMA	Mylar 0.1 $\mu$ F $\pm$ 10%	

Ref. No.	Parts No.	Description	Re- marks
<b>RESISTOR</b>			
Rf1, 2	RS14GB3A472JMA	Metal film 4.7k $\Omega$ $\pm$ 5% 1W	
Rf3, 4	RD14GY2E561JMA	Carbon 560 $\Omega$ $\pm$ 5% 1/4W	
Rf11, 12	RS14GB3A6R8JMA	Metal film 6.8 $\Omega$ $\pm$ 5% 1W	
Rf13, 14	RS14GB3A562JMA	Metal film 5.6k $\Omega$ $\pm$ 5% 1W	
Rf16, 18	RN14BK2E5602F	Metal film 56k $\Omega$ $\pm$ 1% 1/4W	
Rf23~28	RS14GB3A100JMA	Metal film 10 $\Omega$ $\pm$ 5% 1W	
Rf29~34	R92-0115-05	Cement 0.47 $\Omega$ $\pm$ 10% 3W	
Rf35, 37	RS14GB3F100JMA	Metal film 10 $\Omega$ $\pm$ 5% 3W	
<b>SEMICONDUCTOR</b>			
Qf1	V03-1669-10	Transistor 2SC1669	☆
Qf2	V01-0839-10	Transistor 2SA839	☆
Qf3	V03-0452-05	Transistor 2SC1735(D) or (E)	
Qf4	V01-0173-05	Transistor 2SA850(D) or (E)	
Qf5	V03-0215-05	Transistor 2SC1213A(B) or (C)	
Qf6	V01-0073-05	Transistor 2SA673A(B) or (C)	
ICf1	V30-0088-05	IC RC4558T	
Df1, 2	V11-0254-05	Zener diode YZ-140	
Df3~6	V11-0076-06	Diode 1S1555	
Df7	V11-0462-05	Zener diode EQA01-05S	
Df9	V21-0083-05	Varistor STV-3H(Y)	
Df10	V11-0219-05	Diode V06B	
<b>POTENTIOMETER</b>			
VRf1	R12-1002-05	PC trimmer 1k $\Omega$ (B) Voltage ADJ	
<b>MISCELLANEOUS</b>			
-	E10-1407-05	Multi-connector (14P)	☆
-	E10-2206-05	Multi-connector (22P)	
-	E31-0076-05	Lead with connector (Blue)	
-	E31-0090-05	Lead with connector (Black)	
-	E31-0091-05	Lead with connector (Brown)	
-	E31-0092-05	Lead with connector (Red)	
-	E31-0093-05	Lead with connector (Orange)	
-	E31-0094-05	Lead with connector (Yellow)	
-	F20-0078-05	Mica plate x 2	
-	F29-0014-05	Insulating bush x 2	
RLf2	S51-4032-05	Relay	☆

## ADJUSTMENT

### POWER SUPPLY VOLTAGE FOR DIFFERENTIAL AMP

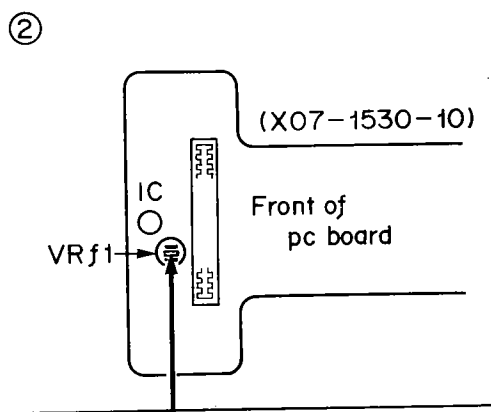
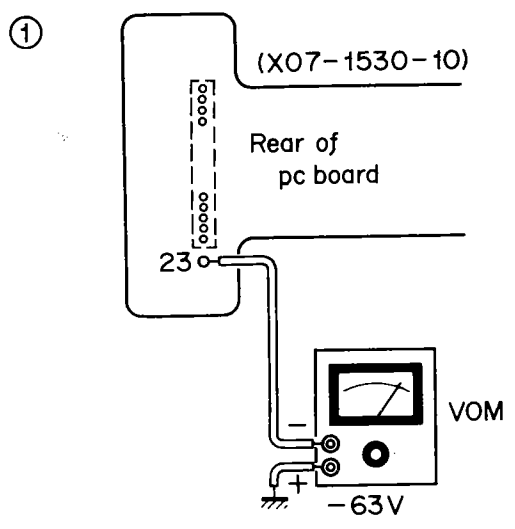

Turn the pc trimmer potentiometer VRf1 until VOM indicates -63V

### CENTER VOLTAGE

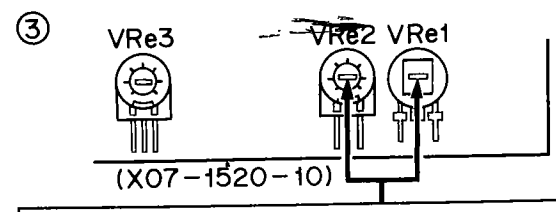
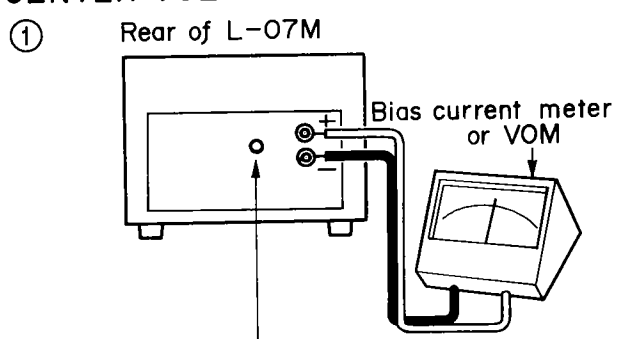

Turn the pc trimmer potentiometer VRe1 until bias current meter or VOM indicates 0V.  
If it is difficult to adjust the center voltage by VRe1, turn the VRe2 until the meter indicates 0V and turn the VRe1 until the meter 0V.

### BIAS CURRENT

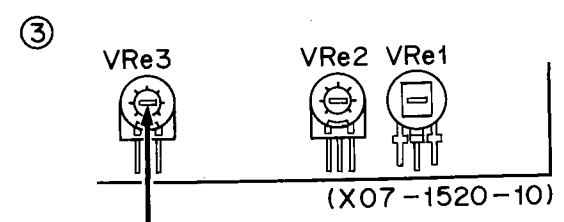
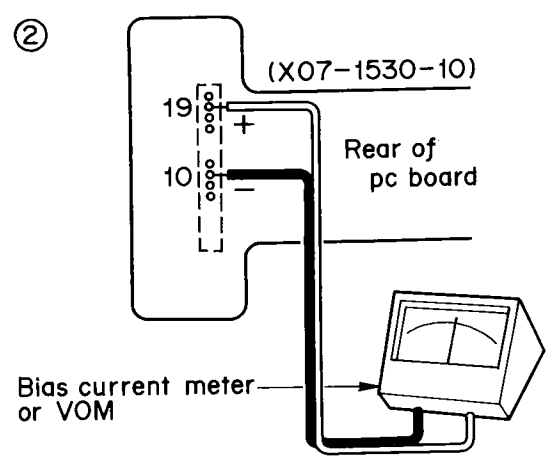
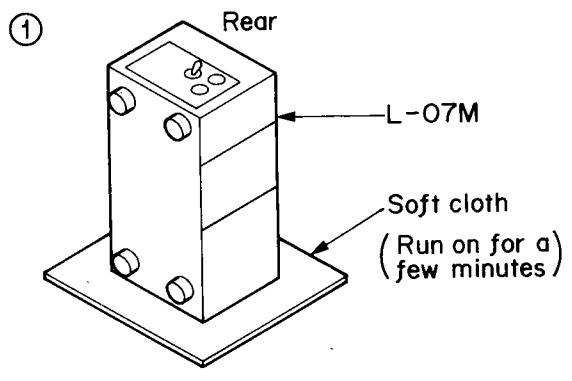

Turn the pc trimmer potentiometer VRe3 until the meter indicates 25mV

PROTECTION (X00-1890-10)

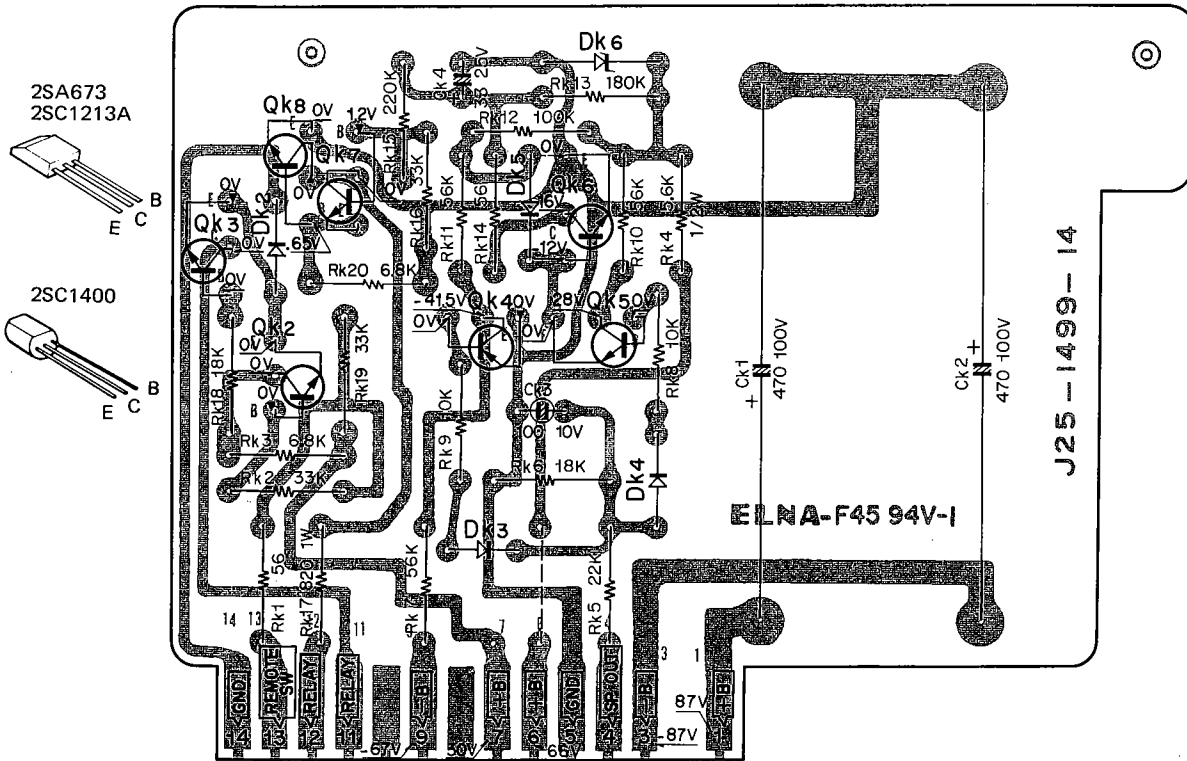
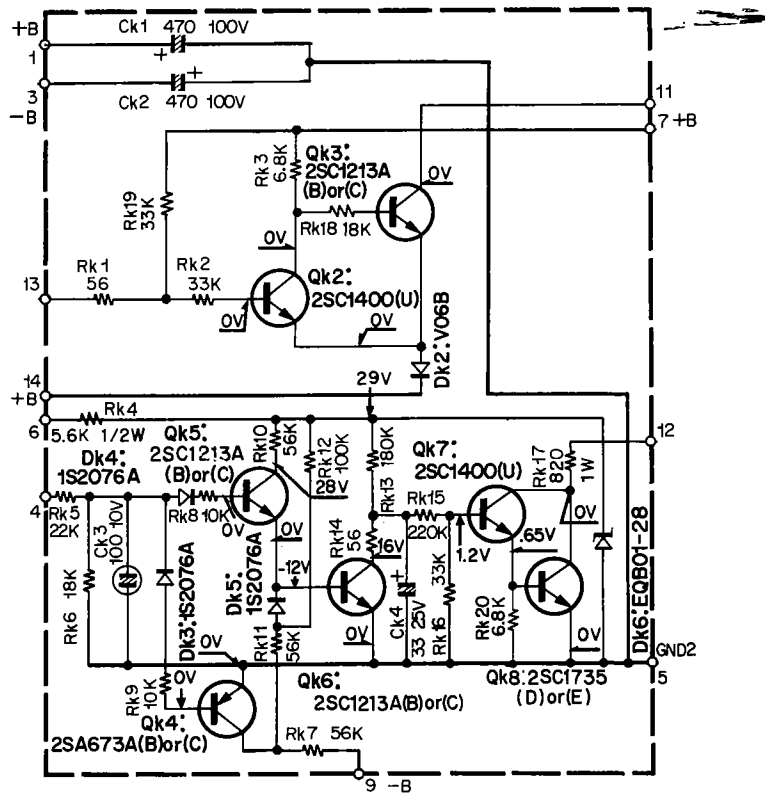

Qk2, 7:2SC1400(U), Qk3, 5, 6:2SC1213A (B) or (C), Qk4:2SA673A (B) or (C), Qk8:2SC1735 (D) or (E), Dk2:V06B, Dk3~5:1S2076A, Dk6:EQB01-28

# POWER SUPPLY (X00-1900-10)

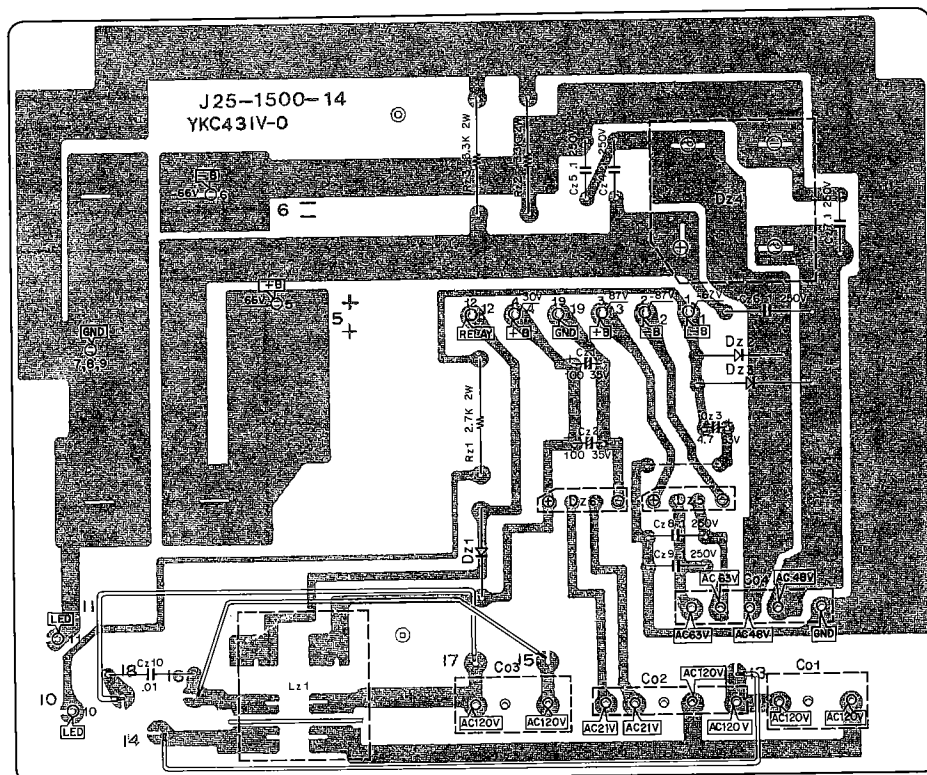
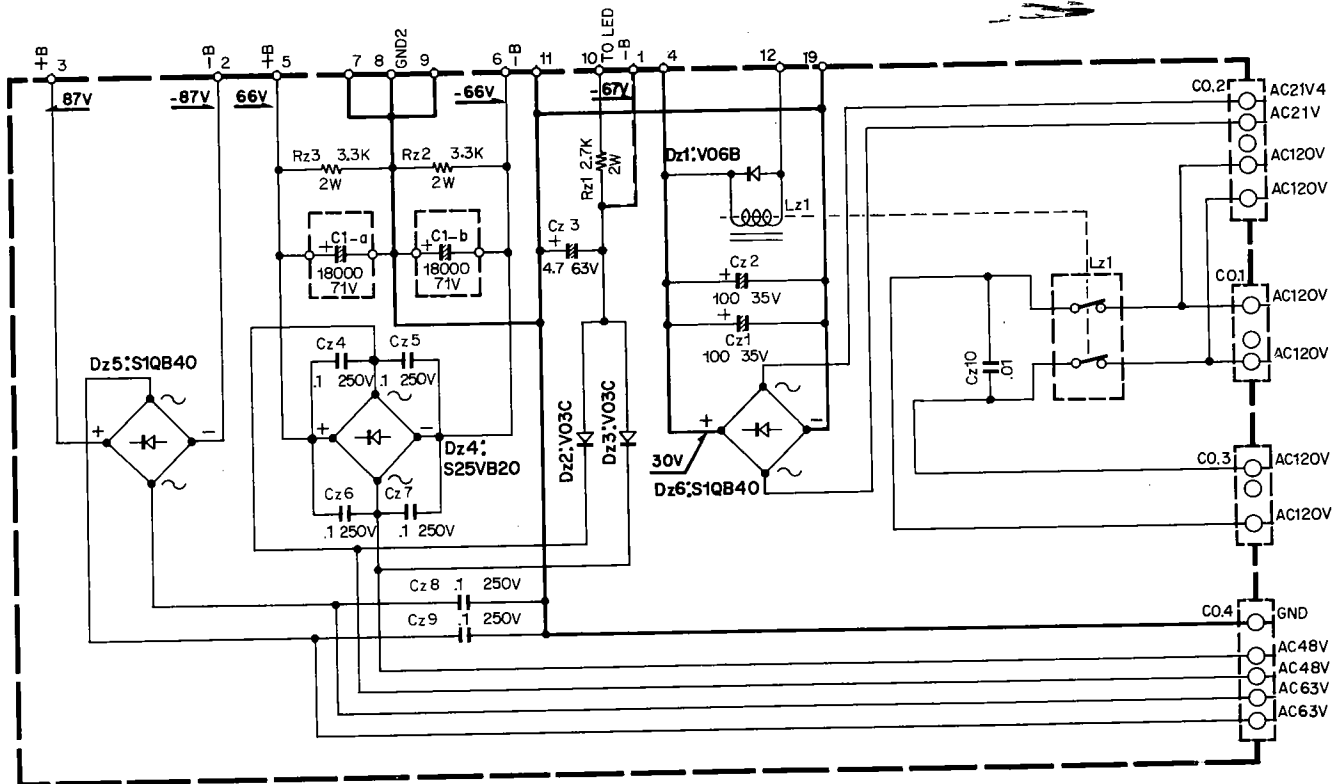

Dz1:V06B, Dz2, 3:V03C, Dz4:S25VB20, Dz5, 6:S1QB40

# POWER AMP (X07-1520-10)

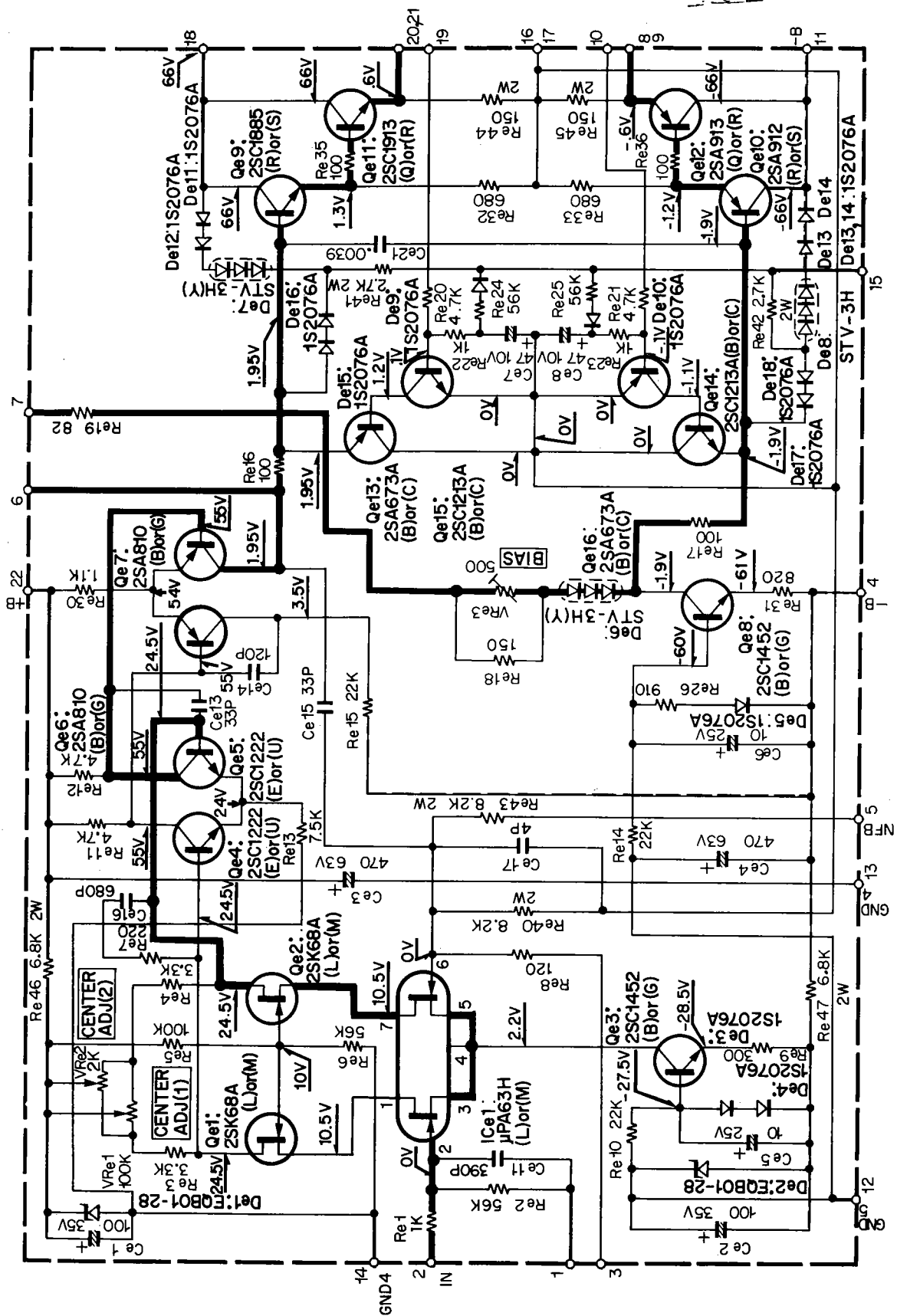

# POWER AMP (X07-1520-10)

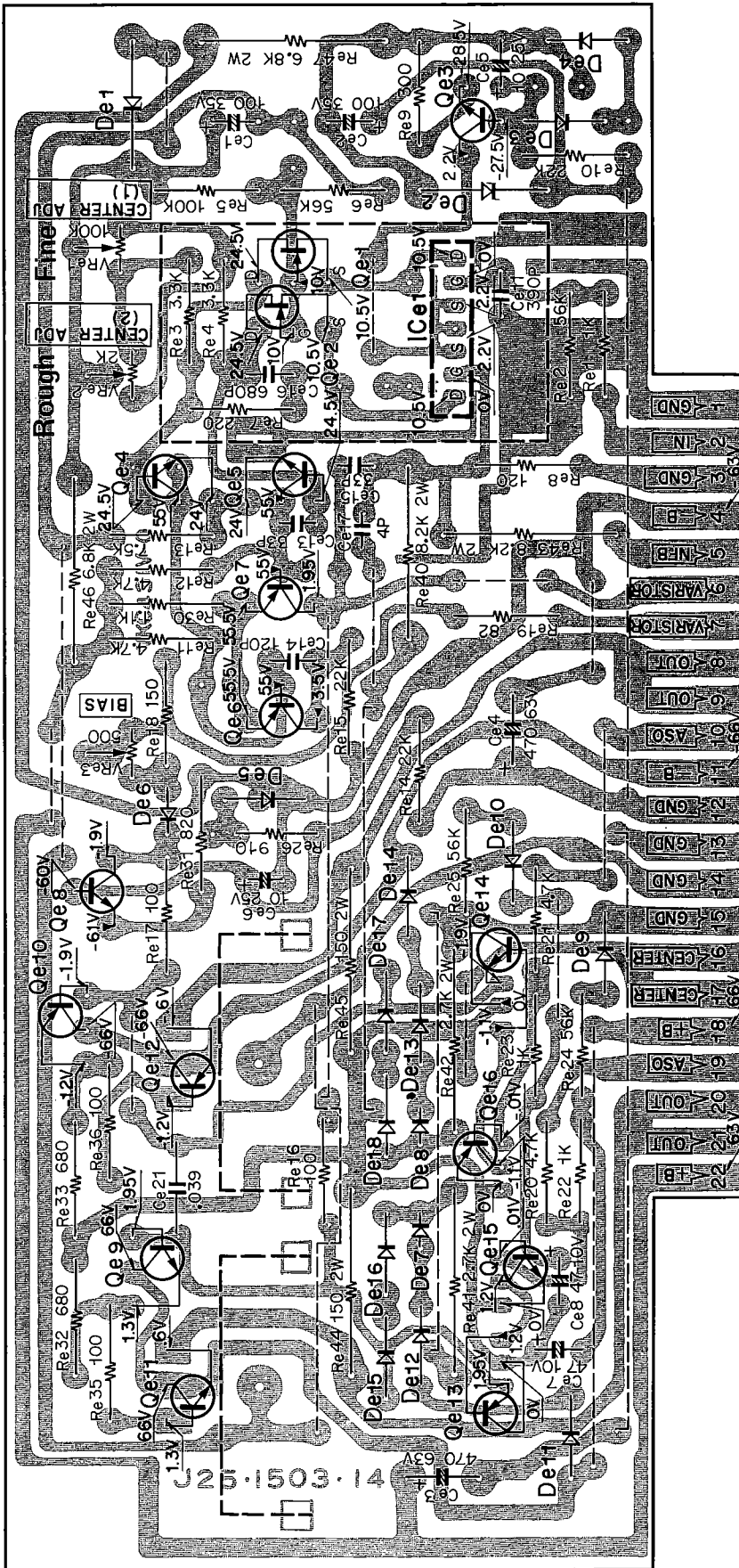

Qe1, 2: 2SK68A (L) or (M), Qe3, 8: 2SC1452 (B) or (G), Qe4, 5: 2SC1222 (E) or (U), Qe6, 7: 2SA810 (B) or (G), Qe9: 2SC1885 (R) or (S),  
 Qe10: 2SA912 (R) or (S), Qe11: 2SC1913 (Q) or (R), Qe12: 2SA913 (Q) or (R), Qe13, 16: 2SA673A (B) or (C), Qe14, 15: 2SC1213A (B) or (C),  
 ICe1:  $\mu$ PA63H (L) or (M), De1, 2: EQB01-28, De3~5, 9~18: 1S2076A, De6~8: STV-3H (Y)

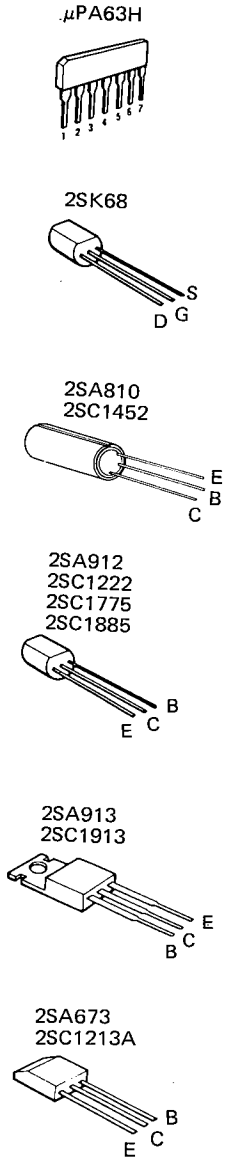

# POWER CONNECTION (X07-1530-10)

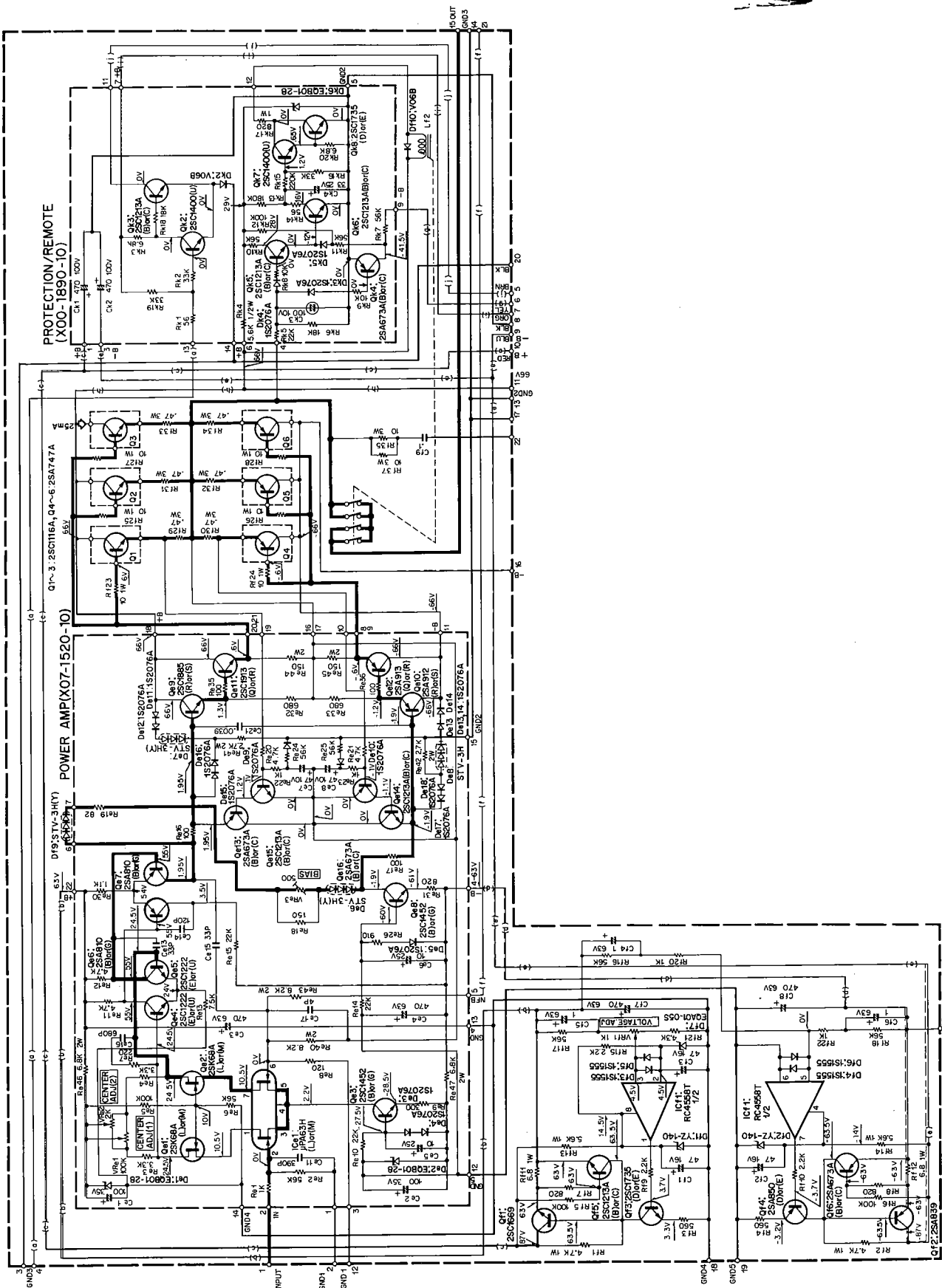



# POWER CONNECTION (X07-1530-10)

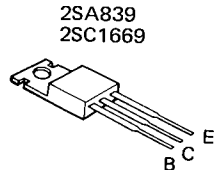
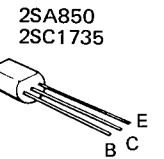
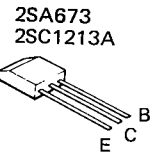
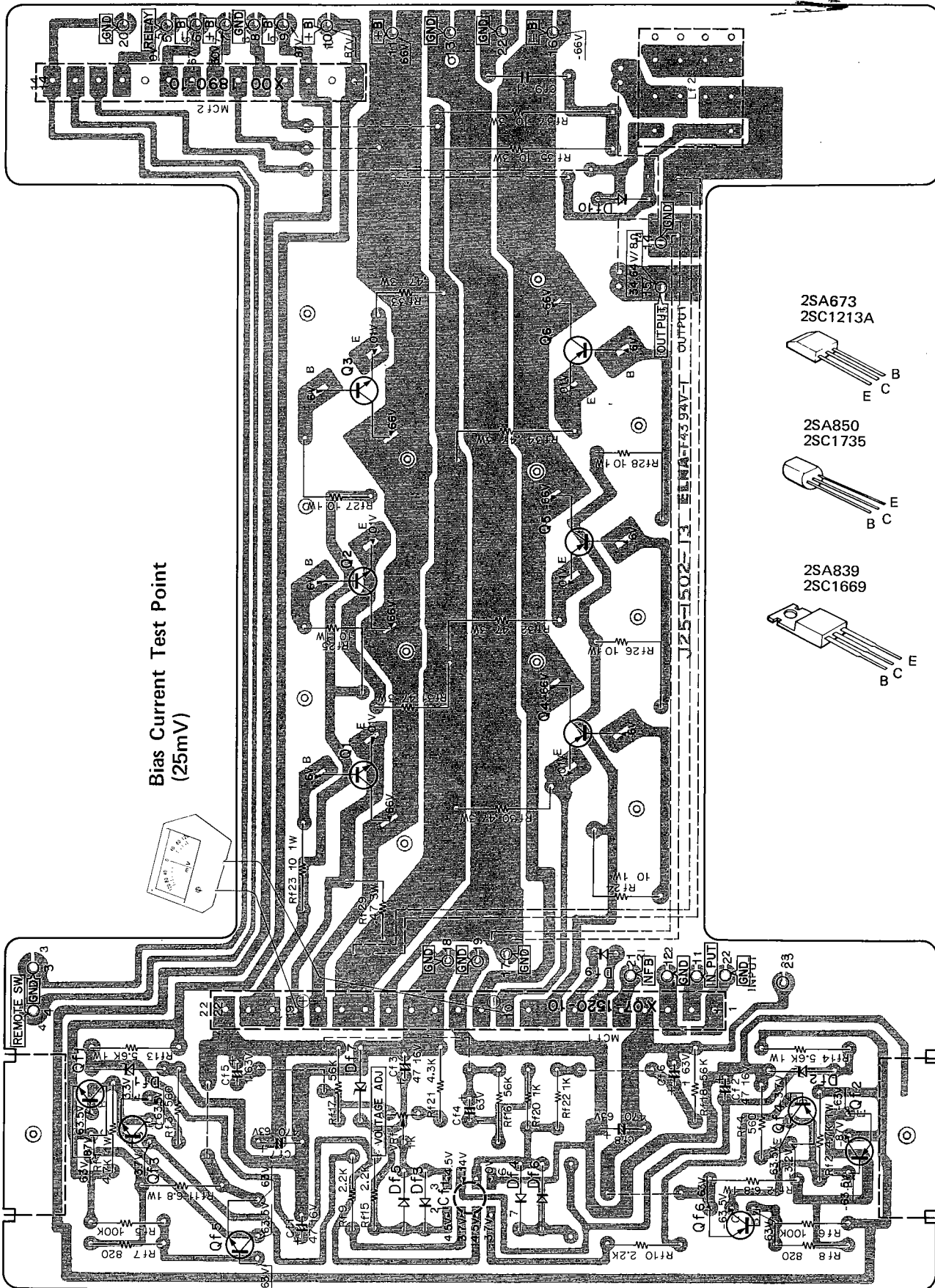

Qf1: 2SC1669, Qf2: 2SA839, Qf3: 2SC1735 (D) or (E), Qf4: 2SA850 (D) or (E), Qf5: 2SC1213A (B) or (C), Qf6: 2SA673A (B) or (C),  
IC1: RC4558T, Df1, 2: YZ140, Df3~6: 1S1555, Df7: EOA01-055, Df9: STV-3H (Y), Df10: V06B

## REVISED CIRCUIT/SEMICONDUCTOR SUBSTITUTIONS

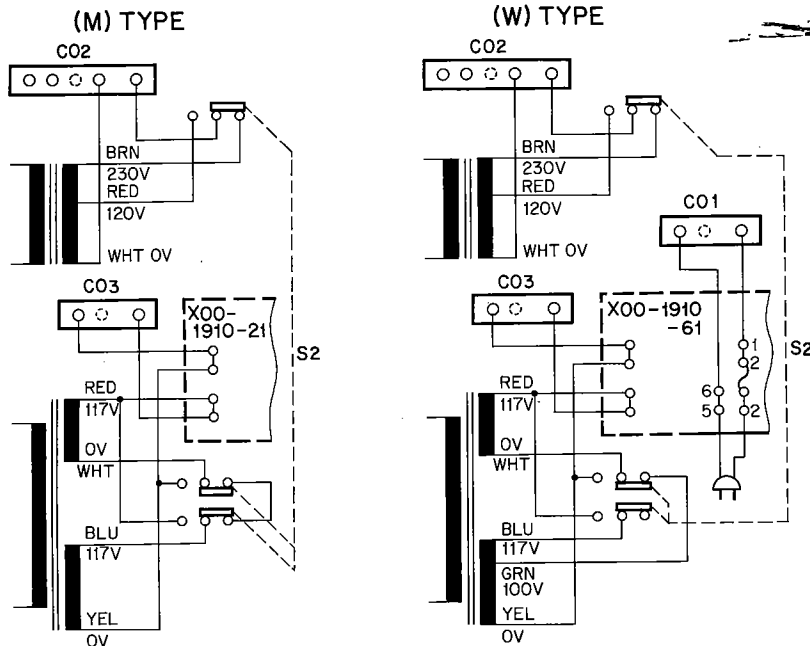

### ABSOLUTE MAX. RATINGS

TRANSISTOR	V <sub>CBO</sub>	V <sub>EBO</sub>	V <sub>CEO</sub>	I <sub>C</sub>	P <sub>C</sub>	T <sub>j</sub>	T <sub>stg</sub>	f <sub>T</sub>	h <sub>fe</sub>
2SA839	-150V	-5V	-150V	-1.5A	25W	150°C	-55~150°C	-	40~240
2SC1669	150V	5V	150V	1.5A	25W	150°C	-55~150°C	-	40~240

DIODE	V <sub>RM</sub>	V <sub>R</sub>	V <sub>I</sub>	I <sub>FM</sub>	I <sub>o</sub>	T <sub>j</sub>	T <sub>stg</sub>	Color
S25VB20	200V	-	-	-	25A (TC=80°C)	150°C	-30~150°C	RED
S1QB40	400V	-	-	-	0.6A	135°C	-30~135°C	YEL

Semiconductor	Substitutions
2SA747A 2SC1116A	2SB655 2SD675
(X00-1890-10) 2SA673A(B),(C) 2SC1213A(B),(C) 2SC1400(U) 2SC1735(D),(E)	2SA850, 2SA777 2SC1735, 2SC1509 2SC1775 2SC1567
(X07-1520-10) 2SA673A(B),(C) 2SA810(B),(G) 2SA912(R),(S) 2SA913(Q),(R) 2SC1222(E),(U) 2SC1213A(B),(C) 2SC1452(B),(G) 2SC1885(R),(S) 2SC1913(Q),(R) 2SK68A(L),(M) μPA63H(L),(M)	2SA850, 2SA777 2SA899 2SA899(B),(V), 2SA809, 2SA810, 2SA915 2SB536(L),(M) 2SC1400, 2SC1681, 2SC1345 2SC1735, 2SC1509 2SC1904 2SC1904(B),(V), 2SC1451, 2SC1452, 2SC1940 2SD381(L),(M)
(X07-1530-10) 2SA673A(B),(C) 2SA839 2SA850(D),(E) 2SC1213A(B),(C) 2SC1669 2SC1735(D),(E) RC4558T	2SA850, 2SA777, 2SA912 2SB536(L),(M) 2SA915, 2SA912 2SC1735, 2SC1885, 2SC1509 2SD381(L),(M) 2SC1567 RC4558TA, B

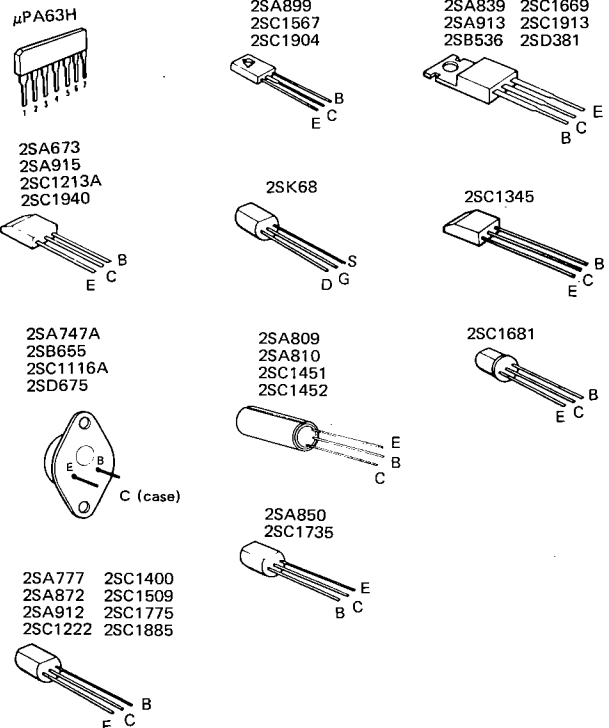

## SPECIFICATIONS

### PERFORMANCE

**150 watts\*** minimum RMS at 8 ohms,  
from 20 Hz to 20,000 Hz with no more  
than 0.008% total harmonic distortion.

Continuous Power	150 watts 8 ohms at 1,000 Hz 200 watts 4 ohms at 1,000 Hz 300 watts 4 ohms at 1,000 Hz
Dynamic Power Output	0.008% at rated power output into 8 ohms
Total Harmonic Distortion (T.H.D.)	20 Hz ~ 20 KHz 0.008% at 15 watts into 8 ohms 20 Hz ~ 20 KHz 0.002% at rated power into 8 ohms 1 KHz 0.003% at 15 watts into 8 ohms 1 KHz 0.003% at rated power into 4 ohms 1 KHz 0.003% at rated power into 4 ohms 1 KHz 0.003% at 20 watts into 4 ohms 1 KHz 0.002% at rated power into 8 ohms 0.002% at 15 watts into 8 ohms 0.003% at rated power into 4 ohms 0.003% at 20 watts into 4 ohms DC ~ 50,000 Hz +0, -0.5 dB DC ~ 150,000 Hz +0, -1.5 dB
Intermodulation Distortion (60 Hz : 7 KHz = 4 : 1)	120 dB (short-circuited) 100 into 8 ohms load 120 into 8 ohms load without Speaker Cable
Frequency Response	1 V/50 K ohms Accept 4 ohms to 16 ohms 0.01 ohms
Signal to Noise Ratio (IHF A Curve)	
Damping Factor	
Input Sensitivity/Impedance	
Speaker Impedance	
Speaker Cable Loss	

### GENERAL

Power Consumption	630 watts at full power 45 watts at non-signal
AC Outlet	1 UNSWITCHED (Except W, L, and T type) (Maximum 300 watts)
Dimensions	W 7-7/8" (200 mm) H 6-3/32" (155 mm) D 15-11/32" (390 mm)
Weight (Net) (Gross)	28.5 lbs. (13 kg) 30.7 lbs. (14 kg)

\* Measured pursuant to Federal Trade Commission's Trade Regulation rule on Power Output Claims for Amplifier.

### KENWOOD ELECTRONICS, INC.

- 15777 SOUTH BROADWAY, GARDENA, CALIFORNIA 90248 U.S.A.
- 75 SEAVIEW DRIVE SECAUCUS, NEW JERSEY 07094 U.S.A.

### TRIO-KENWOOD ELECTRONICS N.V.

- LEUVENSTEENWEG 184,B-1930 ZAVENTEM,BELGIUM.

### TRIO-KENWOOD ELECTRONICS GmbH.

- 6056 HEUSENSTAMM, RUDOLF-BRAAS-STR. 20, WEST GERMANY

### TRIO-KENWOOD FRANCE S.A.

- 15, RUE PAUL BERT, 94200 IVRY-SUR-SEINE, PARIS, FRANCE.

### TRIO-KENWOOD CORPORATION

- 3-6-17 AOBADAI, MEGURO-KU, TOKYO, JAPAN.

# SCHEMATIC DIAGRAM

POWER CONNECTION(X07-1530-10)

POWER AMP(X07-1520-10)

PROTECTION/REMOTE  
(X00-1890-10)

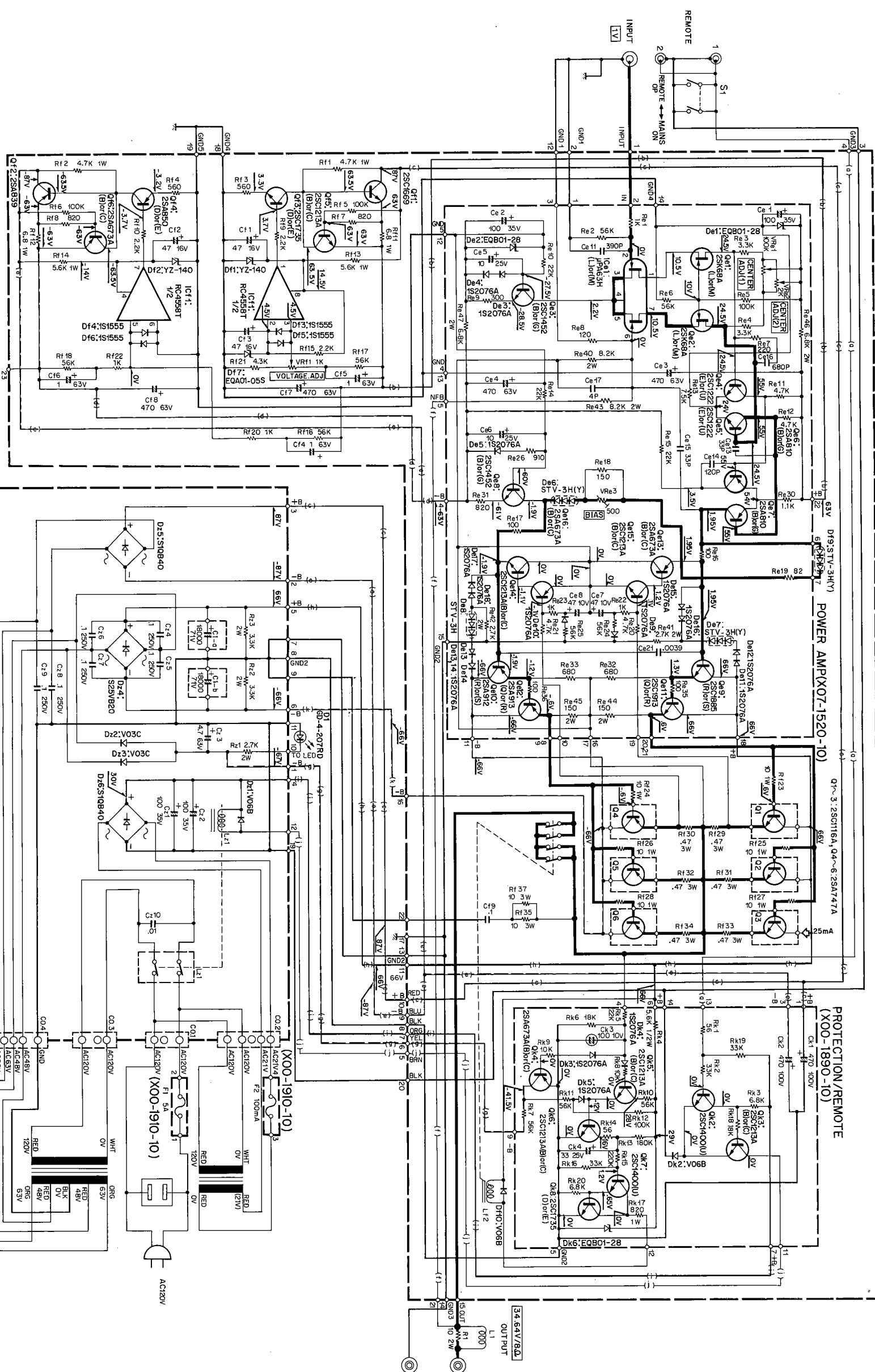

POWER SUPPLY (X00-1900-10)

L-07M(K)

Note: Resistor values are in ohms. K = 1000 ohms, M = 1000 Kohms. Capacitor values are in  $\mu\text{F}$  unless specified. P = pF =  $\mu\text{F} \times 10^{-6}$ . DC voltage are measure with 20 k $\Omega$ /V meter under no signal.