

KENWOOD
HI/FI STEREO COMPONENTS

SERVICE MANUAL

L-07MII

About the circuit description, refer to L-05M and L-07M service manual.



HIGH SPEED DC AMPLIFIER

CONTENTS

EXTERNAL VIEW	3
INTERNAL VIEW	4
DISASSEMBLY FOR REPAIR	5
DESTINATIONS' PARTS LIST	8
PARTS LIST	9
PC BOARD	
PROTECTION (X00-1890-11)	12
POWER SUPPLY (X00-1900-10)	12
POWER CONNECTION (X07-1530-11)	13
POWER AMP (X07-1620-10)	14
SCHEMATIC DIAGRAM	15
SPECIFICATIONS	15
ADJUSTMENT	16
SEMICONDUCTOR SUBSTITUTIONS	16

Note:

Product for Scandinavia (L Type) has a middle case on the heat sink.

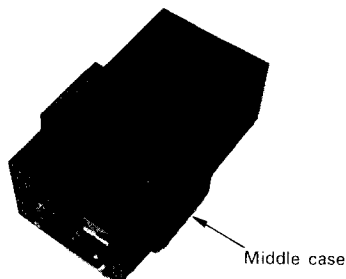

Note:

The products are subject to modification in components and circuits in different countries and regions. This is because each product must be used under the best condition. This manual provides information of modification based on the standard in the U.S., for the convenience of ordering associated components and parts.

U.S.A	K
Canada	P
PX	U
Australia	X
Europe	W
England	T
Scandinavia	L
South Africa	S
Other Area	M

EXTERNAL VIEW

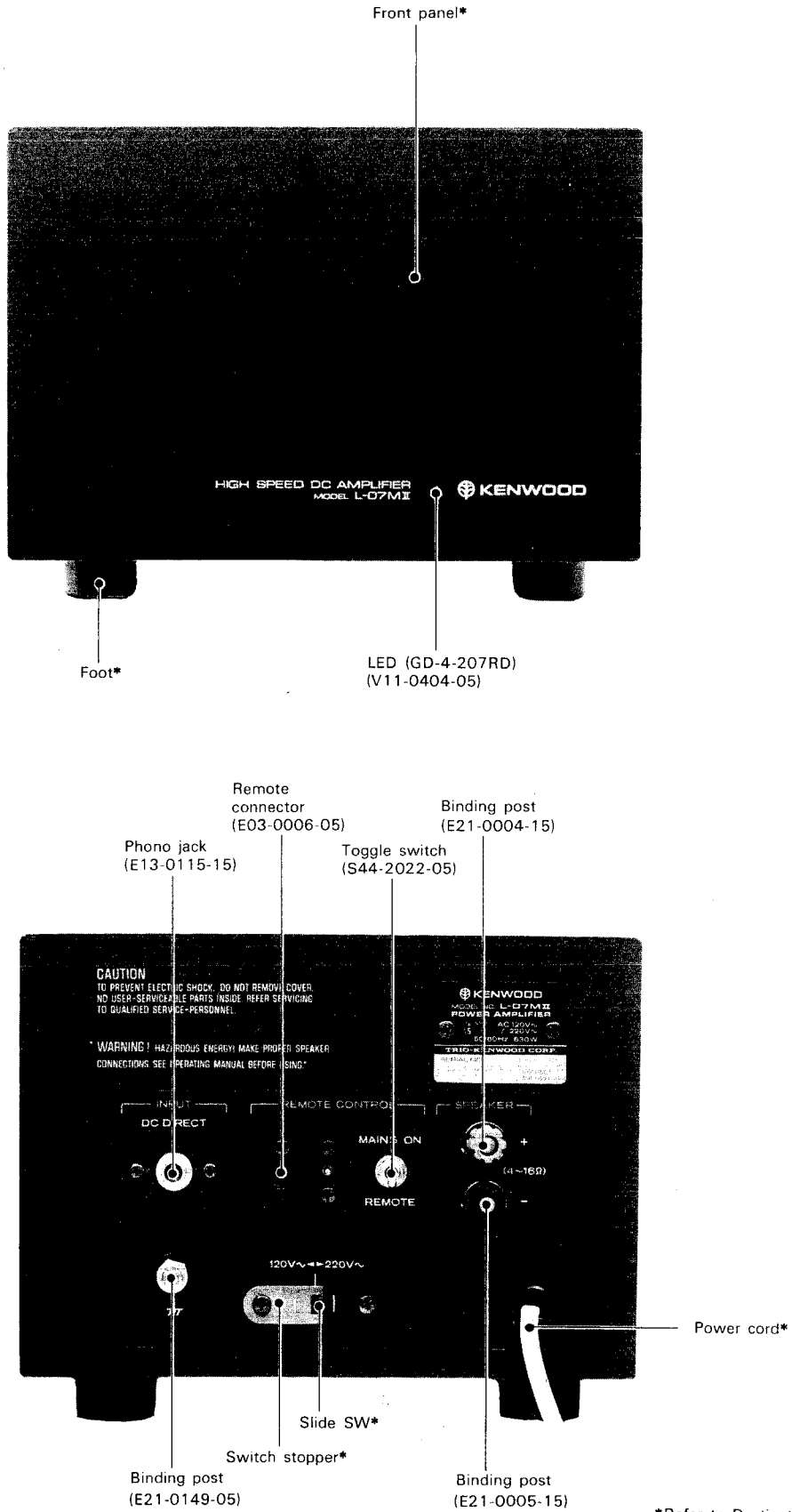

*Refer to Destinations' Parts list (P8)

INTERNAL VIEW

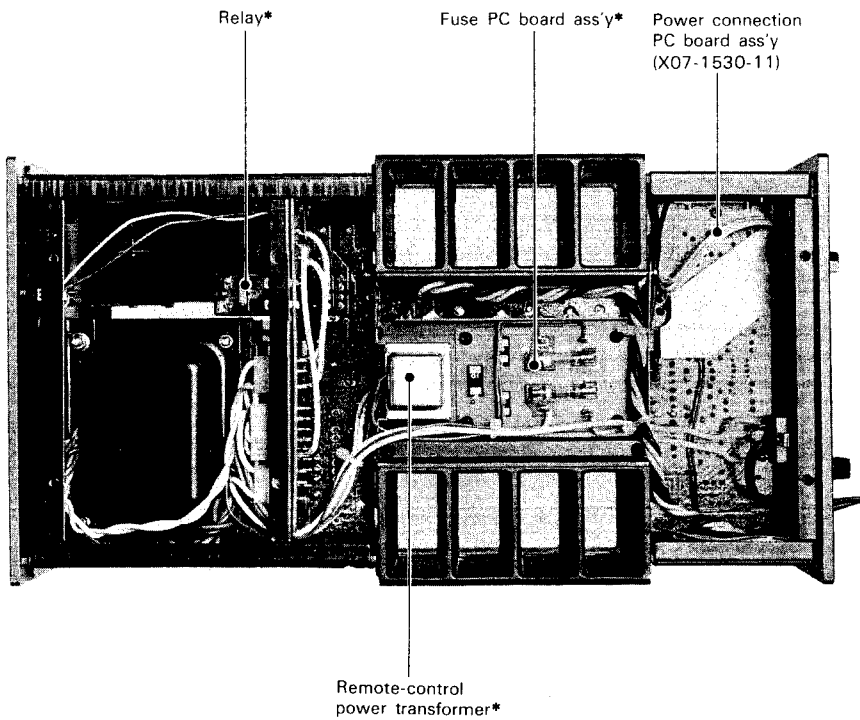
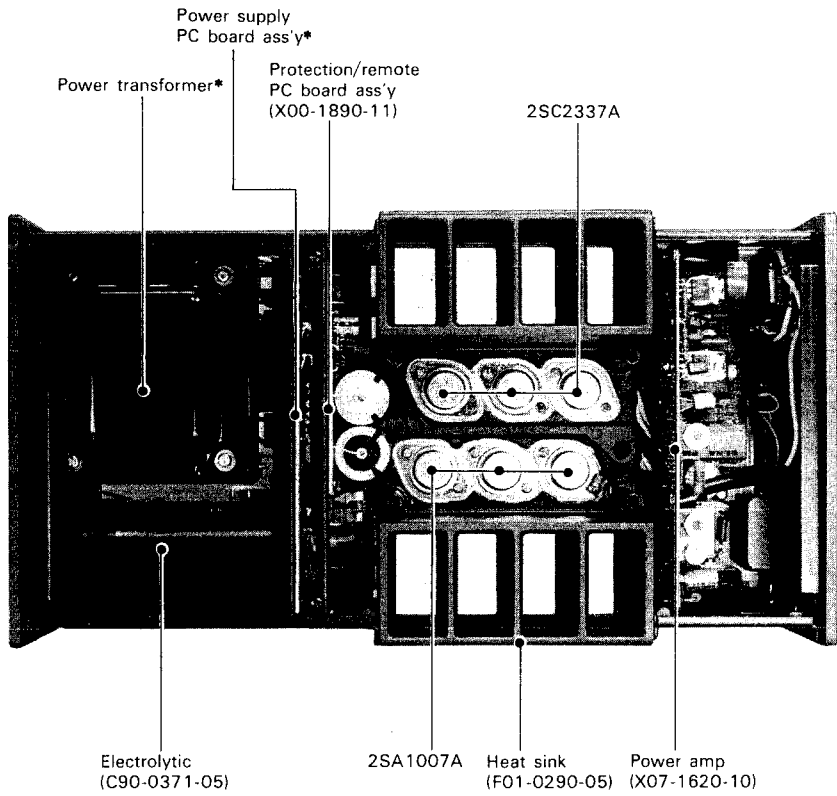

*Refer to Destinations' Parts List (PB)

DISASSEMBLY FOR REPAIR

POWER SUPPLY AND PROTECTION/REMOTE PC BOARD

1. Remove the screw fixing the mounting hardware of the PROTECTION/REMOTE PC board to the frame A.
2. Unscrew the screw fixing the frame A to heat sink.
3. Tilt the front part of unit so that the PC board can be checked easily.

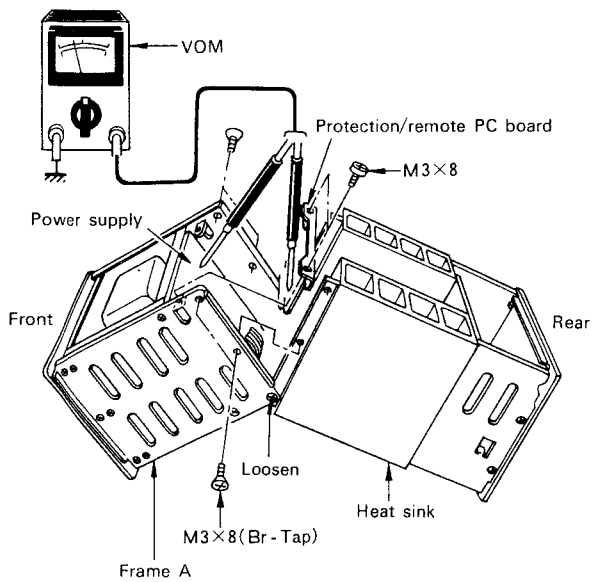

In case of removing 2 screws (one side)

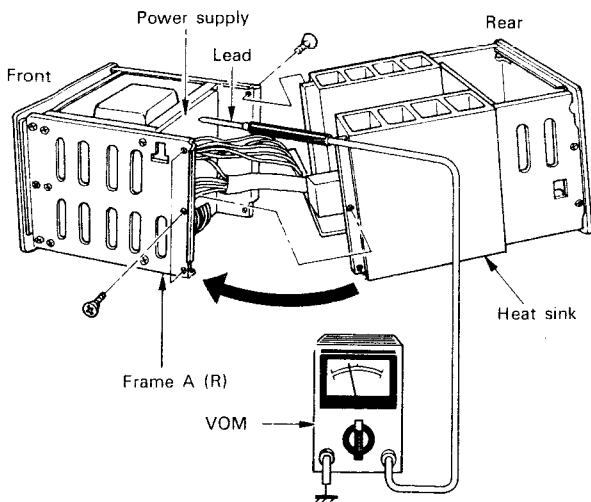

In case of removing all 3 screws (one side)

The Way of Checking Power Supply/Protection PC Board

POWER AMPLIFIER UNIT (X07-1620-10)

The power amplifier PC board is connected with the power connection PC board through plug connectors.

To check and repair the power amplifier PC board:

1. Remove the bus plate fixed on bottom side connected GND binding post.
2. Unscrew the screws which fasten the sub-panel.
3. Tilt the rear panel so that the PC board can be checked easily.

Note:

The rear panel has the power output terminals and power line. Handle the circuit carefully to prevent short-circuiting or shock hazard. To dismantle the printed circuit board from the main body.

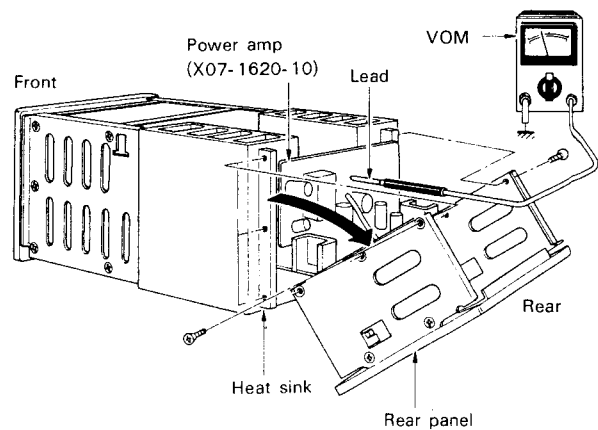

The Way of Checking Power Amp

DISASSEMBLY FOR REPAIR



The case cannot be dismantled unless the bottom plate is removed (Product for Scandinavia has a middle case on the heat sink. The middle case is dismantled easily by removing 6 screws. Before removing the bottom plate, remove the case). Each unit can be dismantled in the following manner:

① FUSE PC BOARD ASS'Y

Unscrew the screw fixing it to the Remote-control power transformer mounting hardware.

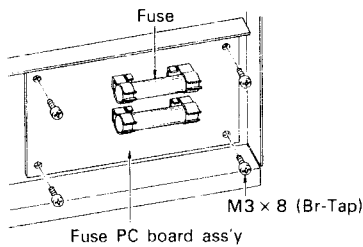

② REMOTE CONTROL POWER TRANSFORMER

Unscrew the screw fixing it to the mounting hardware.

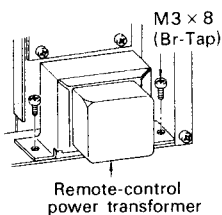

③ FRONT PANEL

Unscrew the screw fixing it to the frame A. Lead of LED should be inserted correctly.

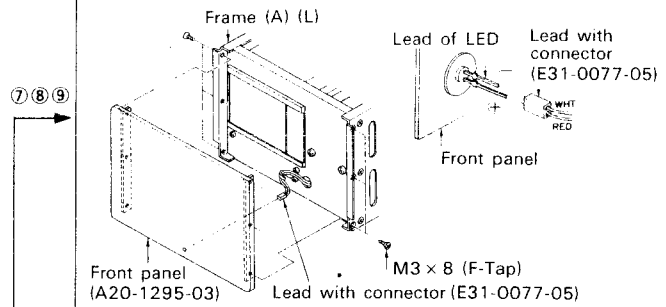

④ REMOTE/PROTECTION PC BOARD ASS'Y

Unscrew the screw fixing it to frame A.

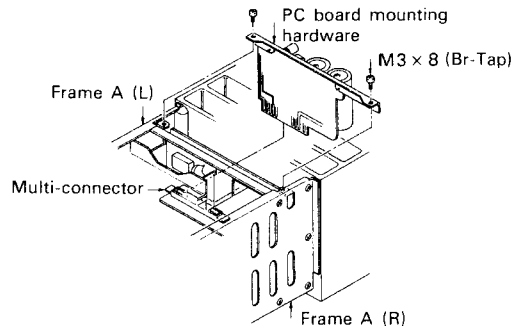

⑤ POWER AMP PC BOARD ASS'Y

Pull out the push rivet fixing it to the sub panel.

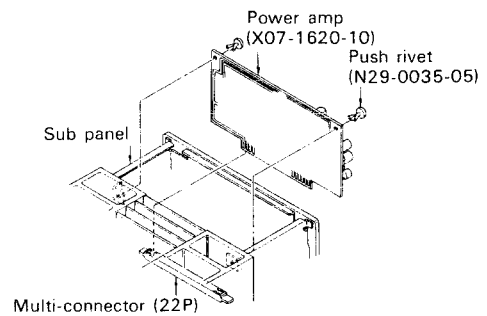

⑥ POWER TRANSISTOR

When replacing the power transistor, remove the heat-sink cover. Power transistor is always mounted in its original position.

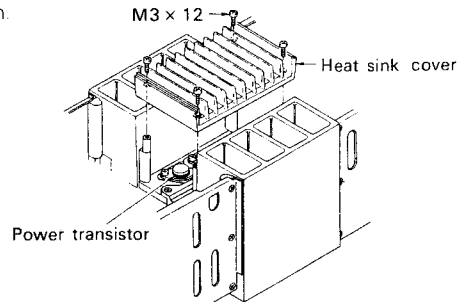

DISASSEMBLY FOR REPAIR

When replacing the lead of friction wafer and mini-connector, push the projection of pin and pull the lead out.

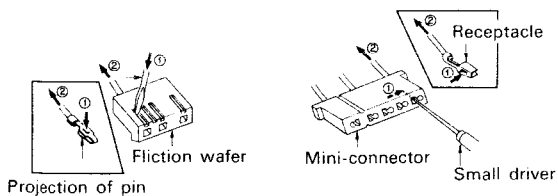

Remove the frame A and unscrew the screw fixing the power transformer and capacitor to the frame C.

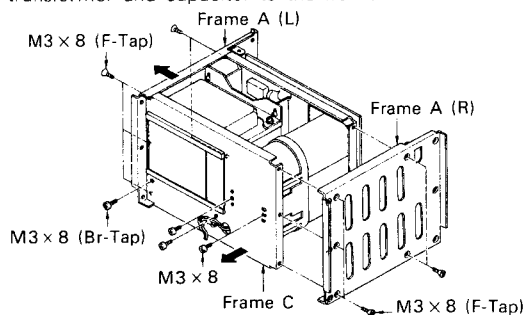

Unscrew the screw fixing the mounting hardware to the heat sink.

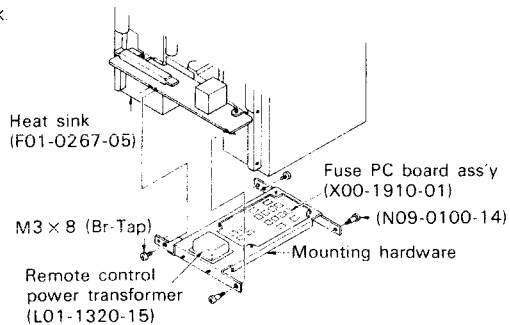

Remove the frame A and bus hardware.

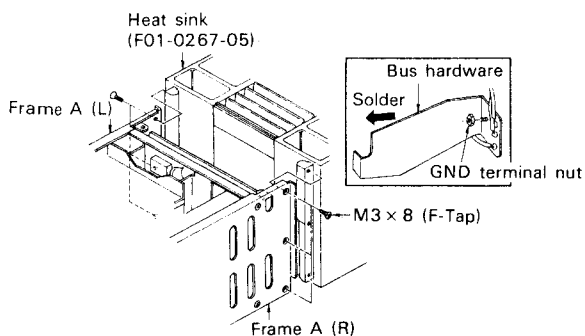

⑦ POWER TRANSFORMER/ELECTROLYTIC BLOCK

When removing the power transformer, unscrew the screw fixing it to the frame. When removing the electrolytic capacitor, unsolder the lug of that.

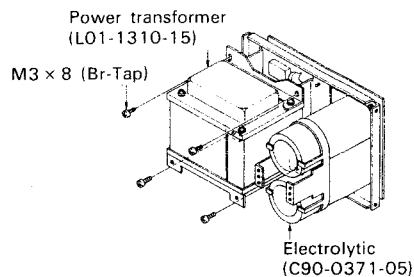

⑧ POWER SUPPLY PC BOARD ASS'Y

Unscrew the screw fixing the PC board to the frame.

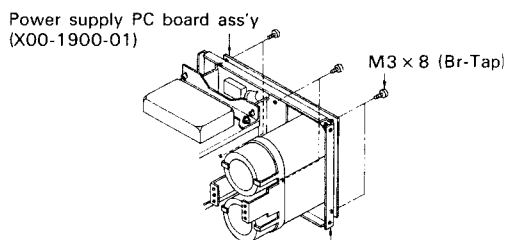

⑨ POWER CONNECTION PC BOARD ASS'Y

Remove the power transistor and unscrew the screw fixing it to the heat sink.

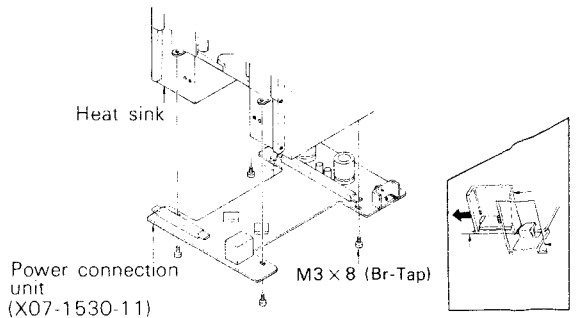

Note:

- As a plug-in board is used, confirm that it is inserted securely when checking the operation.
- When inserting the plug-in board under disassembled condition, take care not to apply force to other board.
- When applying the power under disassembled condition, take care to short circuit or ground floating.

DESTINATIONS' PARTS LIST

☆ : New parts

Ref. No.	U.S.A. (K)	Canada (P)	PX (U)	Australia (X)	Europe (W)	Scandinavia (L)	England (T)	South Africa (S)	Other Area (M)	Description
—	—	—	—	—	—	A01-0342-02	—	—	—	Middle case ☆
—	A20-1294-03	A20-1294-03	—	—	A20-1294-03	A20-1294-03	A20-1292-03	—	A20-1294-03	Front panel ☆
—	A23-0898-13	A23-0899-03	—	—	A23-0898-13	A23-0898-13	A23-0898-13	—	A23-0898-13	Rear panel ☆
—	B46-0061-10	B46-0055-20	—	—	—	—	B46-0060-00	—	—	Warranty card
—	B50-1741-00	B50-1742-00	—	—	B50-1741-00	B50-1741-00	B50-1743-00	—	B50-1742-00	Instruction manual ☆
—	B59-0088-00	B59-0088-00	—	—	B59-0088-00	B59-0088-00	—	—	B59-0088-00	Booklet ☆
—	—	—	—	—	D32-0081-04	—	—	—	D32-0081-04	Switch stopper (Power voltage selector)
—	E03-0008-05	E03-0008-05	—	—	—	—	—	—	E03-0008-05	AC outlet
—	E30-0600-15	E30-0595-15	—	—	E30-0595-15	E30-0595-15	E30-0595-15	—	E30-0595-15	Speaker cord
—	E30-0181-05	E30-0181-05	—	—	E30-0580-05	E30-0292-05	E30-0602-05	—	E30-0515-05	Power cord
—	E31-0074-05	E31-0074-05	—	—	E31-0096-05	E31-0096-05	E31-0096-05	—	E31-0074-05	Lead with connector
—	—	—	—	—	E31-0075-05	—	—	—	E31-0075-05	Lead with connector
—	—	—	—	—	F05-5024-05	—	—	—	F05-5022-05	Spare fuse (5A)
—	H01-1808-04	H01-1811-04	—	—	H01-1808-04	H01-1808-04	H01-1510-04	—	H01-1808-04	Carton case ☆
—	H20-0441-04	H20-0441-04	—	—	H20-0441-04	H20-0441-04	H20-0441-04	—	H20-0417-04	Polyethylene cover
—	J02-0073-04	J02-0049-14	—	—	J02-0049-14	J02-0049-14	J02-0049-14	—	J02-0049-14	Foot × 4
—	—	—	—	—	—	J21-1666-04	J21-1666-04	—	—	Stopping hardware × 2
—	J41-0034-05	J41-0034-05	—	—	J41-0033-05	J41-0033-05	J41-0024-15	—	J41-0033-05	Power cord bushing
—	L01-1611-05 ☆	L01-1617-05 ☆	—	—	L01-1316-05	L01-1312-05	L01-1317-15	—	L01-1315-05	Power transformer
—	L01-1321-15	L01-1321-15	—	—	L01-1324-15	L01-1324-15	L01-1324-15	—	L01-1324-15	Remote-control power transformer
S2	—	—	—	—	S31-3004-05	—	—	—	S31-3004-05	Slide (Power voltage selector)
—	X00-1900-10	X00-1901-01	—	—	X00-1900-61	X00-1901-71	X00-1900-61	—	X00-1900-21	Power supply PC board ass'y
—	X00-1910-10	X00-1910-10	—	—	X00-1910-61	X00-1911-71	X00-1911-71	—	X00-1910-21	Fuse PC board ass'y

Note: Destinations' Parts List of the power supply and the fuse PC board ass'y is written next page.

PARTS LIST

☆ : New parts
 RS: Metal film resistor
 RD: Carbon film resistor

Ref. No.	Parts No.	Description	Re- marks
CAPACITOR			
C1	C90-0371-05	Electrolytic 18,000 μ F 71WV	☆
C2	CQ93AP2A123JMA	Film 0.012 μ F \pm 5%	
RESISTOR			
R1	RS14GB3D100JMA	Metal film 10 Ω \pm 5% 2W	2W
R2	RS14GB3F100JMA	Metal film 10 Ω \pm 5% 3W	3W
SEMICONDUCTOR			
Q1~3	V03-2337-10	Transistor 2SC2337A	☆
Q4~6	V01-1007-10	Transistor 2SA1007A	☆
D1	V11-0404-05	LED GD-4-207RD	
COIL			
L1	L6A-0084-05	Phase compensation coil	☆
SWITCH			
S1	S44-2022-05	Toggle (REMOTE)	
MISCELLANEOUS			
—	A01-0340-02	Front case	☆
—	A01-0341-03	Rear case	☆
—	A40-0191-12	Bottom plate	☆
—	E02-0001-05	Transistor socket \times 6	
—	E03-0006-05	Remote connector \times 2	
—	E13-0115-15	Phono jack (Screw type)	
—	E21-0004-15	1P Binding post (RED)	
—	E21-0005-15	1P Binding post (BLACK)	
—	E21-0149-05	1P Binding post (GND)	
—	E22-0309-05	Lug	
—	E29-0087-14	GND hardware	
—	E20-0090-04	Connecting plate	
—	E30-0594-05	Remote cord ass'y <i>Ferrite core</i>	
—	E31-0080-05	Lead with connector	
—	E31-0088-05	Lead with connector	
—	E31-0095-05	Lead with connector	
—	F01-0290-05	Heat sink \times 2	☆
—	F07-0410-05	Heat sink cover	☆
—	F20-0066-05	Mica plate \times 6	
—	H12-0059-03	Buffer fixture \times 2	
—	J19-0306-05	Lead holder	
—	J30-0137-14	Spacer	
—	X00-1890-11	Protection/Remote PC board ass'y	☆
—	X07-1530-11	Power connection PC board ass'y	☆
—	X07-1620-10	Power amp PC board ass'y	☆

PROTECTION/REMOTE (X00-1890-11)

Ref. No.	Parts No.	Description	Re- marks
CAPACITOR			
Ck1.2	C90-0376-05	Electrolytic 470 μ F 100WV	☆
Ck3	CE04BW1A101MEL	Non-pole electrolytic 100 μ F 10WV	
Ck4	CE04AW1E330MEL	Electrolytic 33 μ F 25WV	

Ref. No.	Parts No.	Description	Re- marks
RESISTOR			
Rk4	RC05GF2H562KKW	Carbon 5.7k Ω \pm 10% 1/2W	
Rk17	RS14GB3A821JMA	Flame proof RS 820 Ω \pm 5% 1W	
SEMICONDUCTOR			
Qk2	V03-0470-05	Transistor 2SC1400(U)	
Qk3	V03-0215-05	Transistor 2SC1213A(B) or (C)	
Qk4	V01-0073-05	Transistor 2SA673A(B) or (C)	
Qk5.6	V03-0215-05	Transistor 2SC1213A(B) or (C)	
Qk7	V03-0470-05	Transistor 2SC1400(U)	
Qk8	V03-0452-05	Transistor 2SC1735(D) or (E)	
Dk2	V11-0219-05	Diode V06B	
Dk3~5	V11-0273-05	Diode 1S2076A	
Dk6	V11-0417-05	Zener diode EQB01-28	

POWER SUPPLY (X00-1900-10)

Ref. No.	Parts No.	Description	Re- marks
CAPACITOR			
Cz1.2	CE04W1V101	Electrolytic 100 μ F 35WV	
Cz3	CE04W1J4R7	Electrolytic 4.7 μ F 63WV	
Cz4~9	C91-0039-05	Mylar 0.1 μ F 250WV	
Cz10	C91-0001-05 or C90-0145-05	Ceramic 0.01 μ F AC125WV Film 0.01 μ F (X00-1900-10)	
	C90-0302-15	Ceramic 0.01 μ F (X00-1900-21)	
	CK45E3D103PMU	Ceramic 0.01 μ F \pm 100% - 0% (X00-1900-61, X00-1901-71)	
	C91-0025-05	Film 0.01 μ F AC125WV (X00-1901-01)	
RESISTOR			
Rz1	RS14AB3D272J	Flame proof RS 2.7k Ω \pm 5% 2W	
Rz2.3	RS14AB3D332J	Flame proof RS 3.3k Ω \pm 5% 2W	
SEMICONDUCTOR			
Dz1	V11-0219-05	Diode V06B	
Dz2.3	V11-0290-05	Diode V03C	
Dz4	V21-0018-05	Diode S25VB20	
Dz5.6	V21-0019-05	Diode S1QB40	
MISCELLANEOUS			
—	E31-0077-05	Lead for connection (LED)	
—	E31-0078-05	Lead with connection	
—	E31-0079-05	Lead with connector	
—	E40-0342-05	Friction lock wafer (3P) \times 2	
—	E40-0580-05	Connector (5P) \times 2	
—	F20-0121-04	Insulator	
RLz1	S51-2035-05 or S51-1024-05	Relay Relay (X00-1901-01)	☆

PARTS LIST

FUSE (X00-1910-10)

Ref. No.	Parts No.	Description	Re- marks
F1	F05-5021-05	Fuse (5A) (X00-1910-10)	
	F05-2521-05	Fuse (2.5A) (X00-1910-21)	
	F05-3122-05	Fuse (3.15A) (X00-1910-61, X00-1911-71)	
F2	F05-1015-05	Fuse (0.1A) (X00-1910-10)	☆
	F05-1012-05	Fuse (0.1A) (X00-1910-21)	
	F05-1013-05	Fuse (0.1A) (X00-1910-61, X00-1911-71)	
—	J13-0052-05	Fuse clip × 4	

Ref. No.	Parts No.	Description	Re- marks
—	E31-0076-05	Lead with connector (Blue)	
—	E31-0090-05	Lead with connector (Black)	
—	E31-0091-05	Lead with connector (Brown)	
—	E31-0092-05	Lead with connector (Red)	
—	E31-0093-05	Lead with connector (Orange)	
—	E31-0094-05	Lead with connector (Yellow)	
—	F29-0014-05	Insulating bush × 2	
RLF2	S51-4032-05	Relay	

POWER CONNECTION (X07-1530-11)

Ref. No.	Parts No.	Description	Re- marks
CAPACITOR			
Cf1~3	CE04W1C470MR	Electrolytic 47 μ F 16WV	☆
Cf6	CE04W2A010MR	Electrolytic 1 μ F 100WV	☆
Cf7,8	CE04W1J471MR	Electrolytic 470 μ F 63WV	☆
Cf9	CQ93AP2A473JMA	Polystyrene 0.047 μ F \pm 5%	
RESISTOR			
Rf1,2	RS14GB3A472JMA	Flame proof RS 4.7k Ω \pm 5% 1W	
Rf3,4	RS14GB3A561JMA	Flame proof RS 560 Ω \pm 5% 1W	
Rf5,6	RN14BK2E104JHO	Metal film 100k Ω \pm 5% 1/4W	
Rf7,8	RN14BK2E821JHO	Metal film 820 Ω \pm 5% 1/4W	
Rf9,10	RN14BK2E222JHO	Metal film 2.2k Ω \pm 5% 1/4W	
Rf11,12	RS14GB3A6R8JMA	Flame proof RS 6.8 Ω \pm 5% 1W	
Rf13,14	RS14GB3A562JMA	Flame proof RS 5.6k Ω \pm 5% 1W	
Rf15	RN14BK2E222JHO	Metal film 2.2k Ω \pm 5% 1/4W	
Rf16	RN14BK2E5602FHO	Metal film 56k Ω \pm 1% 1/4W	
RF17	RN14BK2E563JHO	Metal film 56k Ω \pm 5% 1/4W	
Rf18	RN14BK2E5602FHO	Metal film 56k Ω \pm 1% 1/4W	
Rf20	RS14GA3A102JMA	Flame proof RS 1k Ω \pm 5% 1W	
Rf21	RN14BK2E432JHO	Metal film 4.3k Ω \pm 5% 1/4W	
Rf22	RN14BK2E102JHO	Metal film 1k Ω \pm 5% 1/4W	
Rf23~28	RS14AB3A6R8JMA	Flame proof RS 6.8 Ω \pm 5% 1W	
Rf29~34	R92-0176-05	Cement 0.47 Ω \pm 5% 3W	☆
Rf35,37	RS14GB3F100JMA	Flame proof RS 10 Ω \pm 5% 3W	
SEMICONDUCTOR			
Qf1	V03-1669-00	Transistor 2SC1669	
Qf2	V01-0839-00	Transistor 2SA839	
Qf3	V03-0452-05	Transistor 2SC1735(D) or (E)	
Qf4	V01-0173-05	Transistor 2SA850(D) or (E)	
Qf5	V03-0215-05	Transistor 2SC1213A(B) or (C)	
Qf6	V01-0073-05	Transistor 2SA673A(B) or (C)	
ICf1	V30-0088-05	IC RC4558T	
Df1,2	V11-0254-05	Zener diode YZ-140	
Df3~6	V11-0076-05	Diode 1S1555	
Df7	V11-0462-05	Zener diode EQA01-05S	
Df9	V11-5100-40	Varistor STV-4H(G)	
Df10	V11-0219-05	Diode V06B	
POTENTIOMETER			
VRf1	R12-1002-05	PC trimmer 1k Ω (B) Voltage ADJ	
MISCELLANEOUS			
—	E10-1407-05	Multi-connector (14P)	
—	E10-2206-05	Multi-connector (22P)	

POWER AMP (X07-1620-10)

Ref. No.	Parts No.	Description	Re- marks
CAPACITOR			
Ce1	C91-0062-05	Polystyrene 100pF \pm 10%	☆
Ce2	C91-0058-05	Polystyrene 47pF \pm 10%	☆
Ce3	CQ09S1H392G	Polystyrene 0.0039 μ F \pm 2%	
Ce4	CE04W1E470MR	Electrolytic 47 μ F 25WV	☆
Ce5	CE04W1A470MR	Electrolytic 47 μ F 10WV	☆
Ce6,7	CE04W1E101MR	Electrolytic 100 μ F 25WV	☆
Ce8,9	CE04W1J221MR	Electrolytic 220 μ F 63WV	☆
Ce10	C91-0047-05	Polystyrene 3pF \pm 1%	☆
Ce11	C91-0058-05	Polystyrene 47pF \pm 10%	☆
Ce12	C91-0056-05	Polystyrene 33pF \pm 10%	☆
Ce13	C91-0058-05	Polystyrene 47pF \pm 10%	☆
Ce14	C91-0065-05	Polystyrene 8pF \pm 1%	☆
Ce15	C91-0063-05	Polystyrene 4pF \pm 1%	☆
Ce16	CE04W2A010MR	Electrolytic 1 μ F 100WV	☆
Ce17	CQ93AP2A103J	Mylar 0.01 μ F \pm 5%	
Ce18	C91-0062-05	Polystyrene 100pF \pm 10%	☆
Ce19	C91-0051-05	Polystyrene 12pF \pm 10%	☆
Ce20,21	CE04W1E4R7MR	Electrolytic 4.7 μ F 25WV	☆
Ce22	CE04W1C470MR	Electrolytic 47 μ F 16WV	☆
Ce24	CE04W1A470MR	Electrolytic 47 μ F 10WV	☆
Ce25	CE04W1H010MR	Electrolytic 1 μ F 50WV	☆
Ce26	C91-0055-05	Polystyrene 27pF \pm 10%	☆
RESISTOR			
Re1,2	RN14BK2E471JHO	Metal film 470 Ω \pm 5% 1/4W	
Re3	RN14BK2E563JHO	Metal film 56k Ω \pm 5% 1/4W	
Re4	RN14BK2E223JHO	Metal film 22k Ω \pm 5% 1/4W	
Re5	RN14BK2E823JHO	Metal film 82k Ω \pm 5% 1/4W	
Re6	RN14BK2E683JHO	Metal film 68k Ω \pm 5% 1/4W	
Re7,8	RN14BK2E202JHO	Metal film 2k Ω \pm 5% 1/4W	
Re9	RN14BK2E390JHO	Metal film 39 Ω \pm 5% 1/4W	
Re10	RN14BK2E301JHO	Metal film 300 Ω \pm 5% 1/4W	
Re11	RN14BK2E223JHO	Metal film 22k Ω \pm 5% 1/4W	
Re12,13	RS14GB3A472JMA	Flame-proof RS 4.7k Ω \pm 5% 1W	
Re14,15	RS14GB3A911JMA	Flame-proof RS 910 Ω \pm 5% 1W	
Re16	RN14BK2E432JHO	Metal film 4.3k Ω \pm 5% 1/4W	
Re17	RN14BK2E100JHO	Metal film 10 Ω \pm 5% 1/4W	
Re18	RN14BK2E391JHO	Metal film 390 Ω \pm 5% 1/4W	
Re19	RS14GB3A101JMA	Flame-proof RS 100 Ω \pm 5% 1W	
Re20	RS14GB3D682JMA	Flame-proof RS 6.8k Ω \pm 5% 2W	
Re21,22	RS14GB3A221JMA	Flame-proof RS 220 Ω \pm 5% 1W	
Re23	RS14GB3A220JMA	Flame-proof RS 22 Ω \pm 5% 1W	
Re24,25	RS14GB3A240JMA	Flame-proof RS 24 Ω \pm 5% 1W	
Re26,27	RN14BK2E273JHO	Metal film 27k Ω \pm 5% 1/4W	
Re28,29	RN14BK2E472JHO	Metal film 4.7k Ω \pm 5% 1/4W	
Re30,31	RN14BK2E332JHO	Metal film 3.3k Ω \pm 5% 1/4W	

PARTS LIST

Ref. No.	Parts No.	Description	Re- marks
Re32,33	RN14BK2E563JHO	Metal film 56kΩ ±5% 1/4W	
Re34,35	RS14GB3D272JMA	Flame-proof RS 2.7kΩ ±5% 2W	
Re36	RS14GB3A620JMA	Flame-proof RS 62Ω ±5% 1/4W	
SEMICONDUCTOR			
Qe1,2	V09-0092-05	FET 2SK68A(L), (M)	
Qe3	V09-0129-10	Dual FET 2SK109(D), (E)	
Qe4~6	V03-0477-05	Transistor 2SC1775(E), (F)	
Qe7,8	V01-0199-05	Transistor 2SA899(B), (V)	
Qe9	V03-0460-05	Transistor 2SC1904(B), (V)	
Qe10	V01-0084-05	Transistor 2SA733(Q), (R)	
Qe11,12	V03-0270-05	Transistor 2SC945(Q), (R)	
Qe13	V01-0084-05	Transistor 2SA733(Q), (R)	
Qe14	V03-0468-05	Transistor 2SC1913(Q), (R)	
Qe15	V01-0188-05	Transistor 2SA913(Q), (R)	
De1,2	V11-0435-05	Zener Diode EQA01-24R	
De3~5	V11-0271-05	Diode 1S2076	
De6~8	V11-0273-05	Diode 1S2076A	
De9,10	V11-5100-10	Varistor STV-4H(W)	
De11~1	V11-0273-05	Diode 1S2076A	
De16	V11-0271-05	Diode 1S2076	
POTENTIOMETER			
VRe1	R12-5022-05	PC Trimming 100kΩ Offset	
VRe2	R12-1031-05	PC Trimming 2.2kΩ Offset	
VRe3	R12-0501-05	PC Trimming 100Ω Bias	

Note:

Resistors except the special type (example: cement, metal film, etc.) are not detailed in PARTS LIST. With regard to the value, refer to the schematic diagram or the PC board illustration.

Resistors not detailed are carbon type (1/4W or 1/8W).

You should give an order for the carbon resistors according to the ways described as follows:

A carbon resistor's part number is example RD14BY 2E 222J

1. Kinds of the carbon resistor



2. Wattage

1/4W → 2E
1/8W → 2B

3. Resistance value

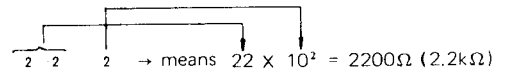

Significant figure Multiplier

Example:

221 → 220Ω
222 → 2.2kΩ
223 → 22kΩ
224 → 220kΩ
225 → 2.2MΩ

4. Tolerance

J = ±5% (Gold color)
K = ±10% (Silver color)

PC BOARD

PROTECTION/REMOTE (X00-1890-11)

Note:

DC voltage of parentheses in X00-1890-11 is measured across #14 terminal.

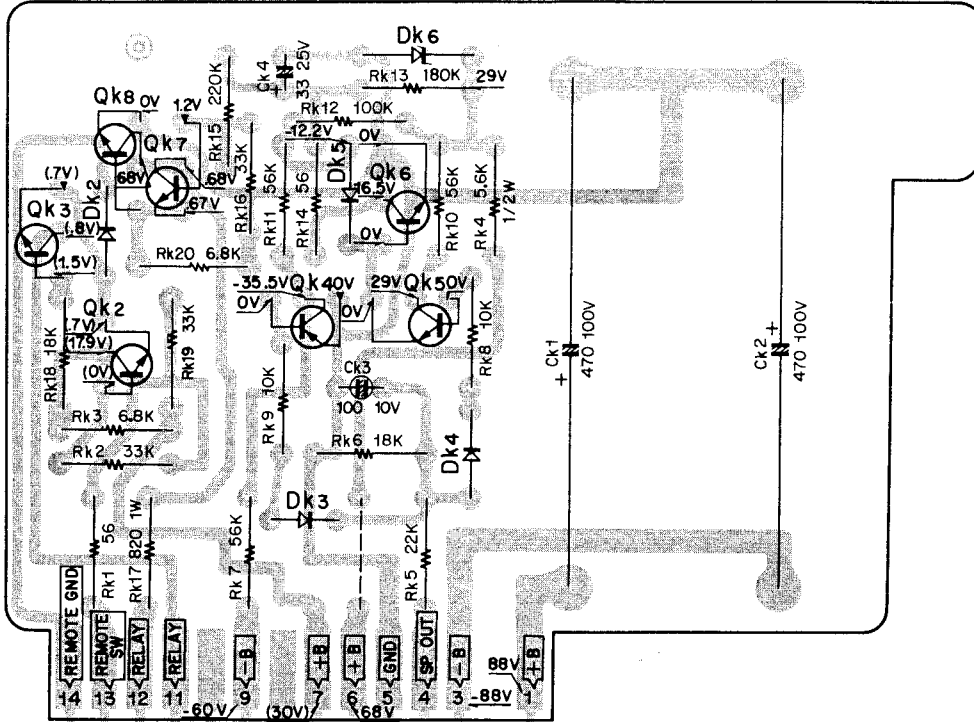

Qk2,7:2SC1400(U), Qk3,5,6:2SC1213A(B) or (C), Qk4:2SA673A(B) or (C),
 Qk8:2SC1735(D) or (E), Dk2:V06B, Dk3~5:1S2076A, Dk6:EQB01-28

POWER SUPPLY (X00-1900-10)

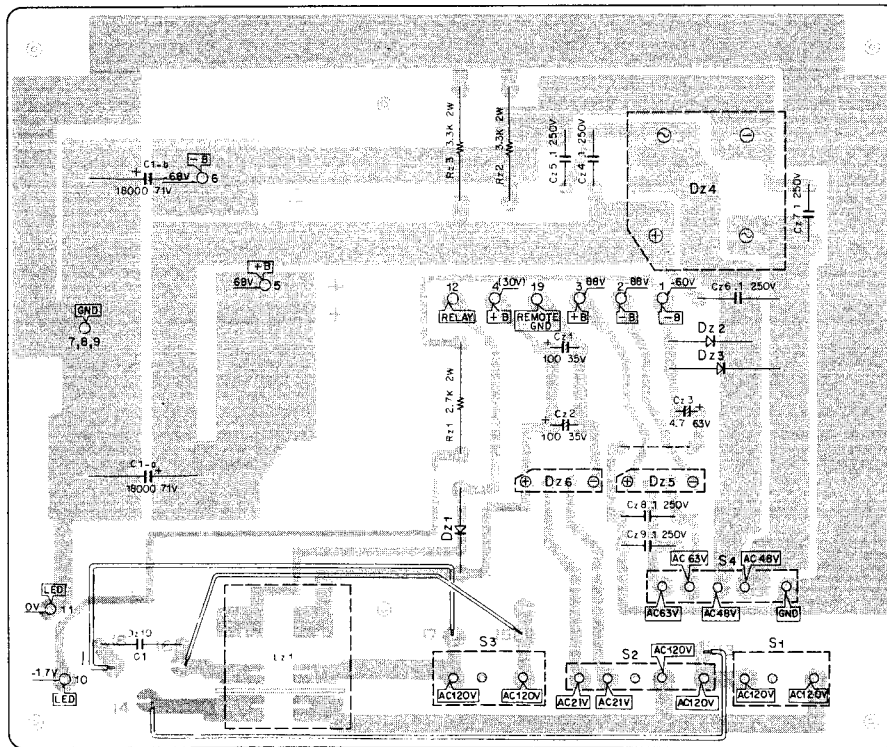

Dz1:V06B, Dz2,3:V03C, Dz4:S25VB20, Dz5,6:S1QB40

POWER CONNECTION (X07-1530-11)

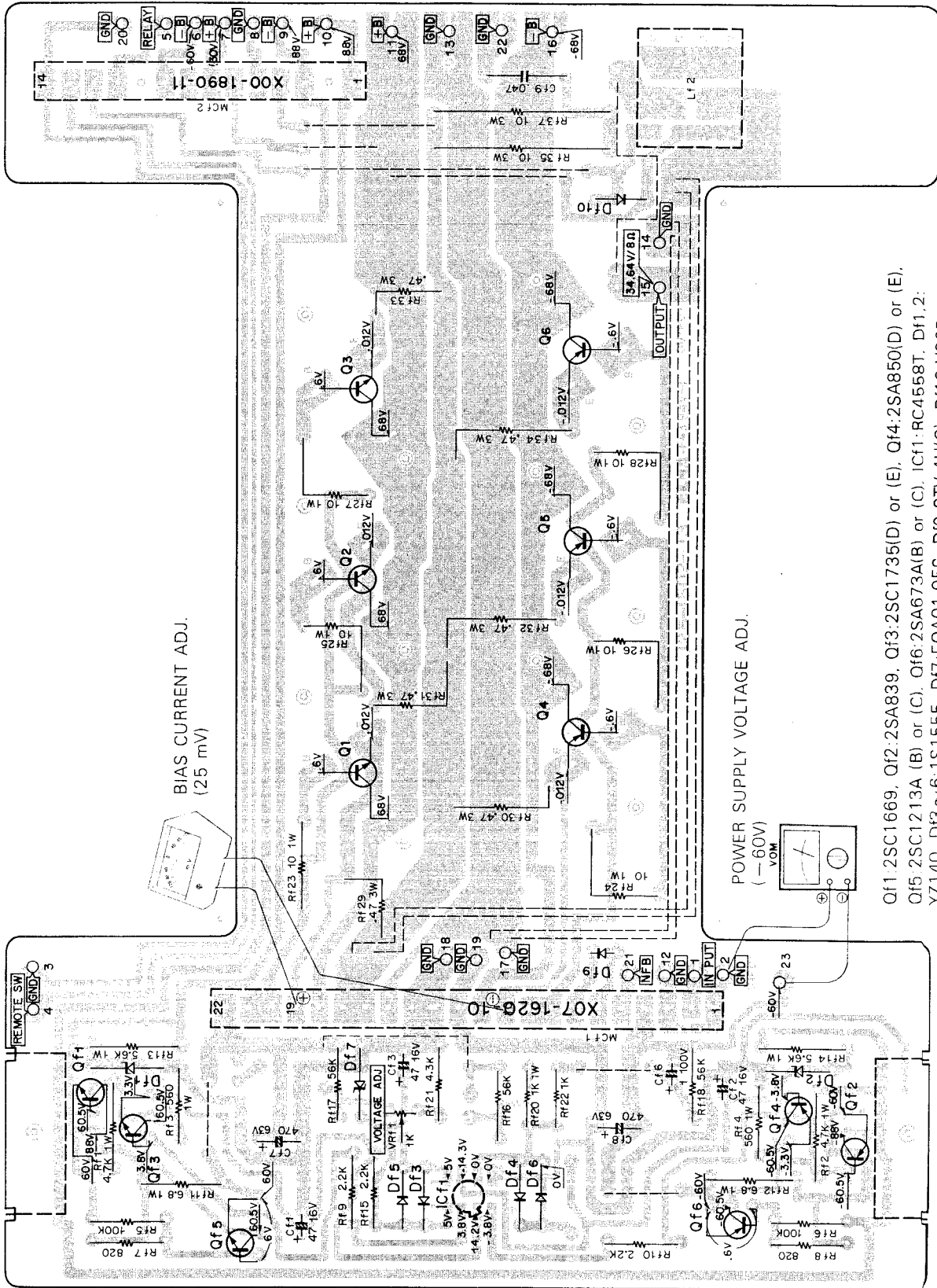

Q1: 2SC1669, Q2: 2SA839, Q3: 2SC1735(D) or (E), Q4: 2SA850(D) or (E),
 Q5: 2SC1213A (B) or (C), Q6: 2SA673A(B) or (C), IC1: RC4558T, Df1, 2:
 YZ140, Df3~6: 1S1555, Df7: EQA01-05S, Df9: STV-4H(G), Df10: V06B

PC BOARD

POWER AMP (X07-1620-10)

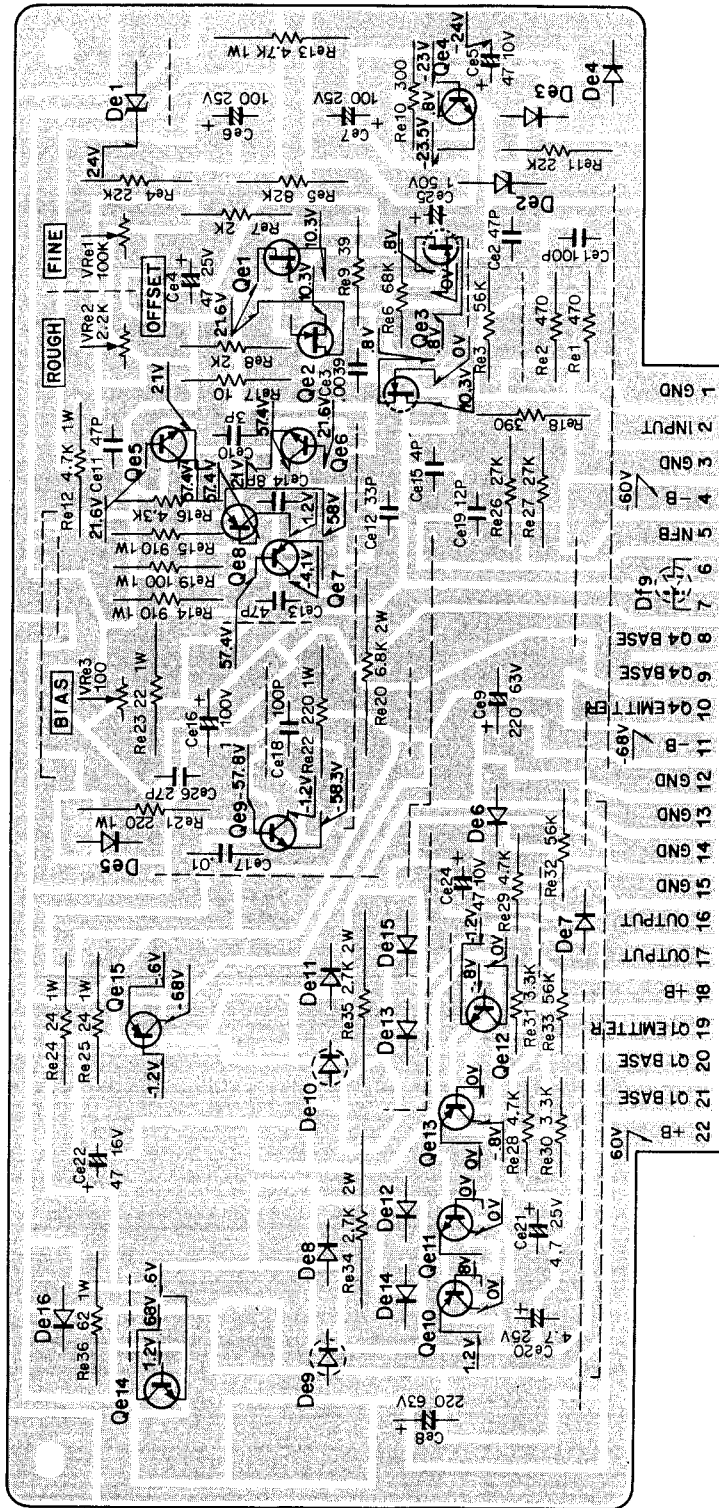

Qe1,2:2SK68A(L,M), Qe3:2SK109(D,E), Qe4~6:2SC1775(E,F), Qe7,8:2SA899(B,V), Qe9:2SC1904 (B,V), Qe10,13:2SA733 (Q,R),
 Qe11,12:2SC945(Q,R), Qe14:2SC1913(Q,R), Qe15:2SA913(Q,R), De1,2:EQAO1-24R, De3~5,16:1S2076, De6~8, 11~15:1S2076A
 De9,10:STV-4H(W)

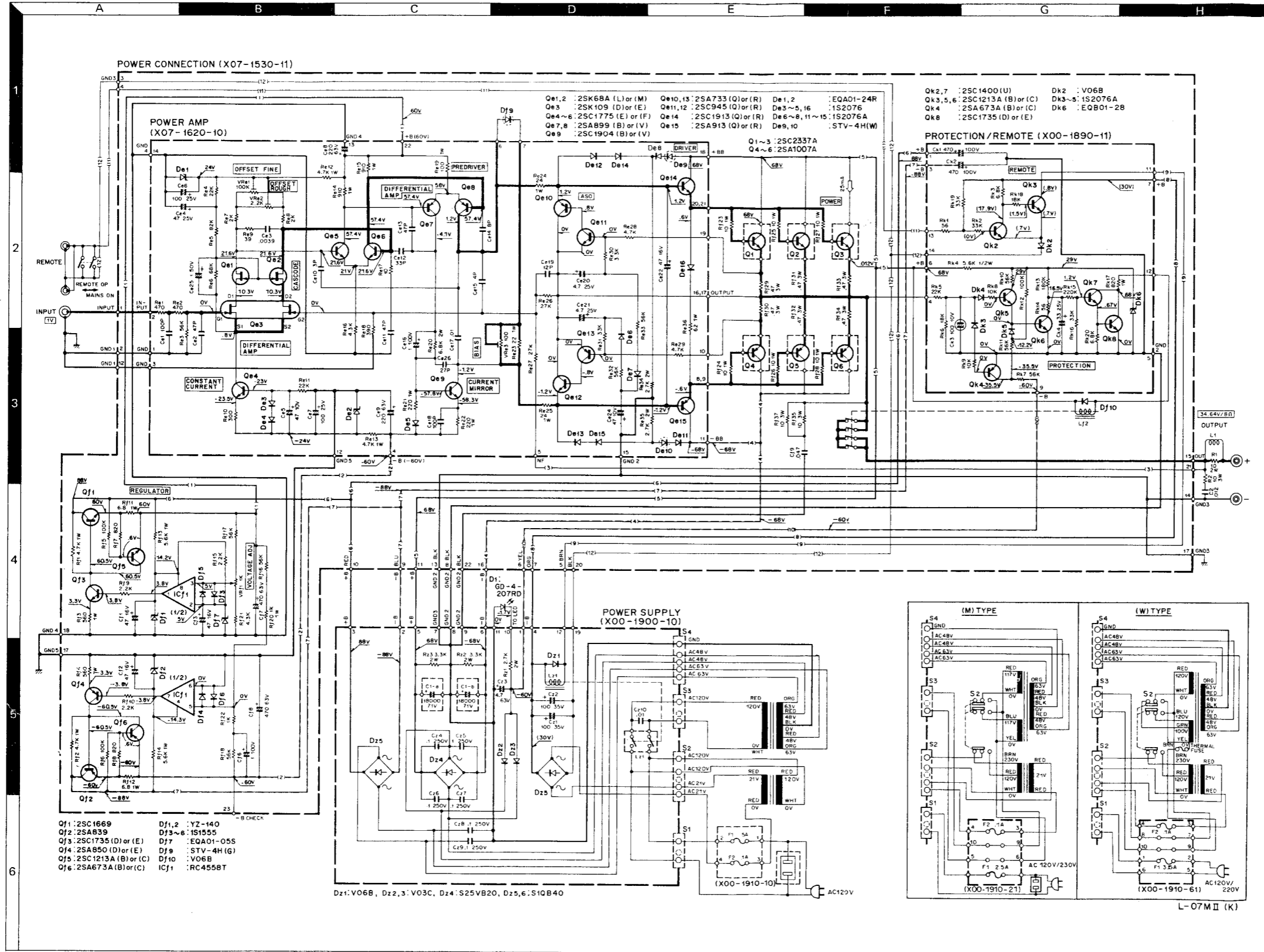

Specifications described here are based on the measurement using the special speaker cable with length of one meter provided.

POWER OUTPUT
150 watts* minimum RMS at 8 ohms, from 20 Hz to 20,000 Hz with no more than 0.007% total harmonic distortion.

Continuous Power
 8 ohms at 1,000 Hz 150 watts
 4 ohms at 1,000 Hz 200 watts

Total Harmonic Distortion
 10 Hz ~ 100 kHz, 8 ohms at rated power ... 0.08%
 20 Hz ~ 20 kHz, 8 ohms at rated power ... 0.007%
 20 Hz ~ 20 kHz, 8 ohms at 1/10 rated power 0.008%
 1 kHz, 8 ohms at rated power 0.003%
 1 kHz, 4 ohms at rated power 0.0035%

Intermodulation Distortion
 (60 Hz : 7 kHz = 4 : 1)
 8 ohms at rated power 0.003%
 8 ohms at 1/10 rated power 0.002%
 4 ohms at rated power 0.08%

Frequency Response DC ~ 600 Hz ± 0 dB
Signal to Noise Ratio (short-circuited) 120 dB

Damping Factor
 DC ~ 20 kHz, 8 ohms 120
 DC ~ 20 kHz, 8 ohms without speaker cable 150
 DC ~ 80 kHz, 8 ohms without speaker cable 80

Input Sensitivity/Impedance 1V/50k ohms

Transient Response
 Rise time
 -1V \rightarrow +1V 0.55 μ s
 -20V \rightarrow +20V 0.55 μ s
 -40V \rightarrow +40V 0.55 μ s
 Slew rate +170V/ μ s -170V/ μ s

Speaker Impedance Accept 4 ohms to 16 ohms speaker impedance
Speaker Cable Loss 0.01 ohms

GENERAL
Power Consumption
 At full power 630 watts
 At non-signal 45 watts
AC Outlet 1 Unswitched
Dimensions W 7-7/8" (200 mm)
 H 6-3/32" (155 mm)
 D 15-11/32" (390 mm)

Weight (Net) 28.5 lbs. (13 kg)
(Gross) 30.7 lbs. (14 kg)

* Measured pursuant to Federal Trade Commission's Trade Regulation rule on Power Output Claim for Amplifier in U.S.A.

Note: Kenwood follows a policy of continuous advancement in development. For this reason specifications may be changed without notice.

Note:

- Resistor values are indicated in ohm (K: 1000-ohms, M: 1000k ohms). Non specified resistors are 1/4W, and $\pm 5\%$.
- Capacitor values are in μ F (1P = μ F = pF = $10^{-12} \times F$, μ F $10^{-6} \times F$). Non specified capacitors are 50WV.
- Inductance values are in Henry.
- DC voltages are measured with 20k Ω /V VOM at no signal between GND.
- DC voltage of parenthesis in REMOTE PC board ass'y is measured between #14 of X00-1890-11.

ADJUSTMENT

POWER SUPPLY VOLTAGE FOR DIFFERENTIAL AMP

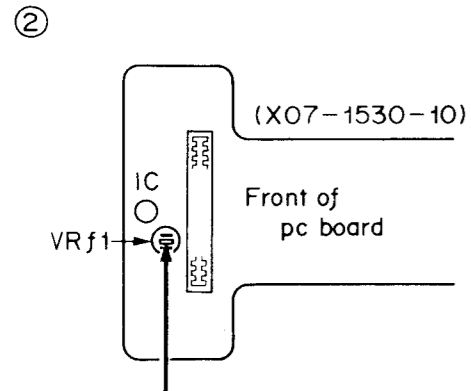
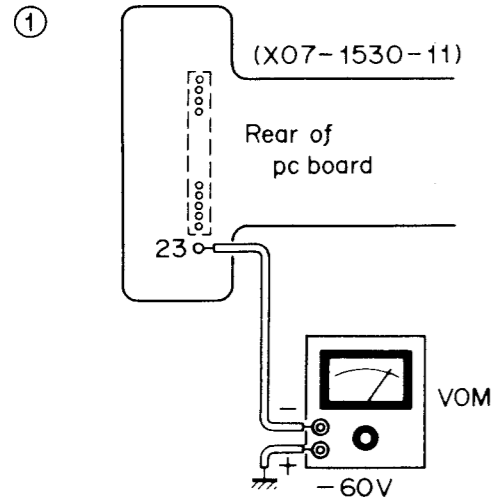

Turn the pc trimmer potentiometer VRf1 until VOM indicates -60V

OFFSET VOLTAGE

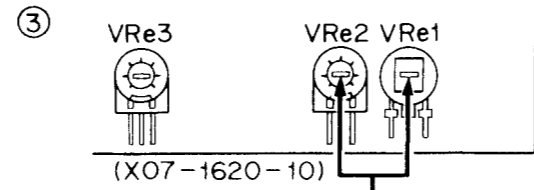
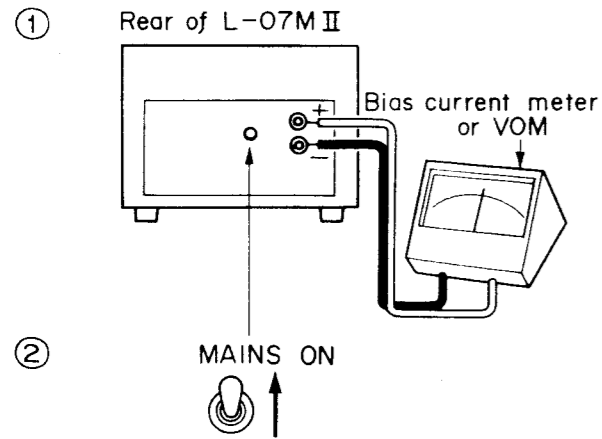

Turn the pc trimmer potentiometer VRe1 until bias current meter or VOM indicates 0V. If it is difficult to adjust the center voltage by VRe1, turn the VRe2 until the meter indicates 0V and turn the VRe1 until the meter 0V.

BIAS CURRENT

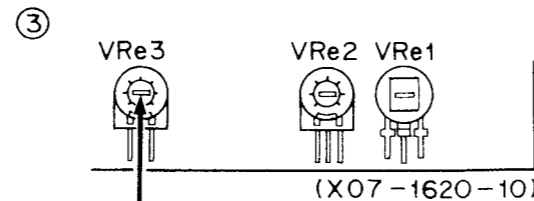
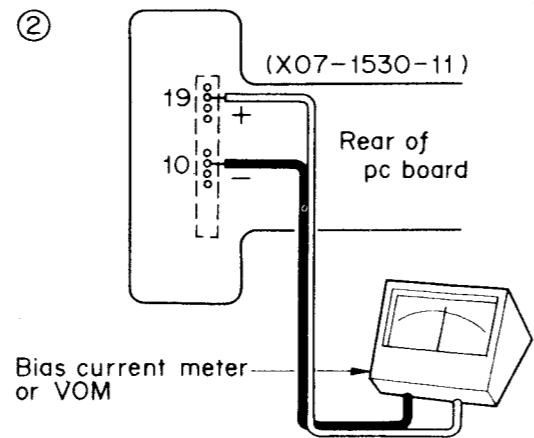
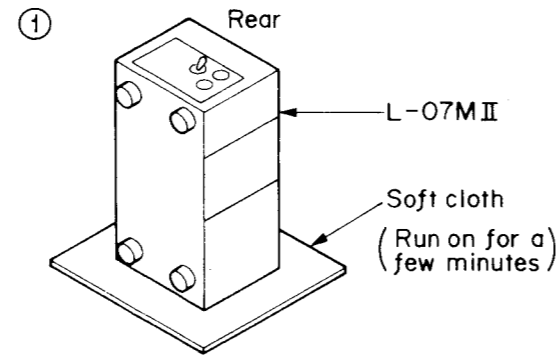

Turn the pc trimmer potentiometer VRe3 until the meter indicates 25mV

In the case of using the substitutive semiconductor, you should confirm the leads of one.

Semiconductor	Substitutions
2SA1007A 2SC2337A	—
(X00-1890-11) 2SA673A(B), (C) 2SC1213A(B), (C) 2SC1400(U) 2SC1735(D), (E)	2SA850, 2SA777 2SC1735, 2SC1509 2SC1775 2SC1567
(X07-1530-11) 2SA673A(B), (C) 2SA839 2SA850 2SC1213A(B), (C) 2SC1669 2SC1735(D), (E) RC4558T	2SA850, 2SA777, 2SA912 2SB536(L), (M) 2SA915, 2SA912 2SC1735, 2SC1885, 2SC1509 2SD381(L), (M) 2SC1567
(X07-1620-10) 2SA733(Q), (R) 2SA899(B), (V) 2SA913(Q), (R) 2SC945(Q), (R) 2SC1904(B), (V) 2SC1913(Q), (R) 2SC1775(E), (R) 2SK68A(L), (M) 2SK109(D), (E)	— 2SA872, 2SA750 — 2SB536(L), (M) 2SC1775, 2SC1400 — 2SD381(L), (M) V _{ceo} ≥ 80V, P _c ≥ 250mW 2SK30A μPA63H

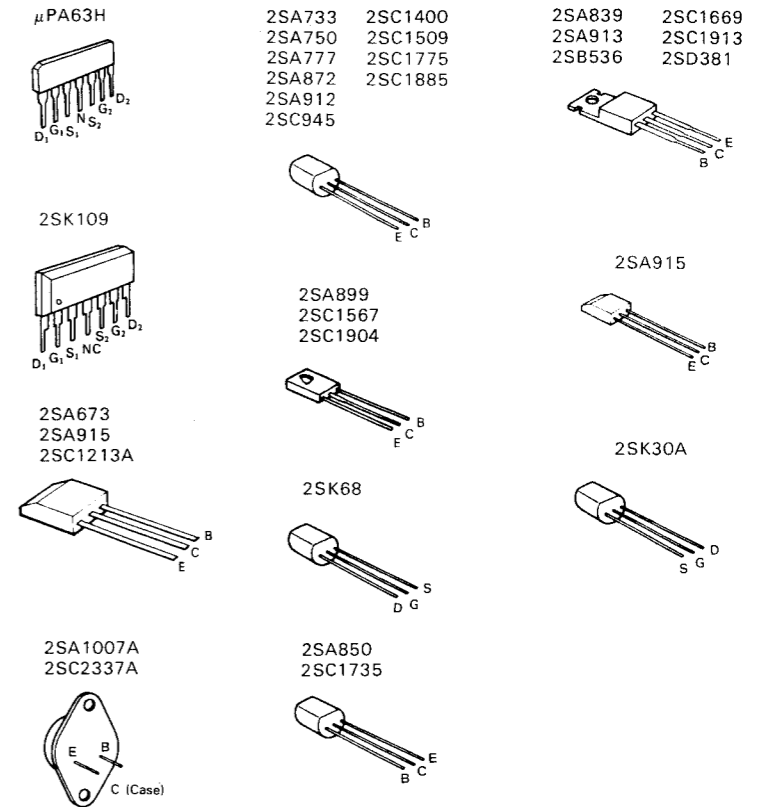

A product of
TRIO-KENWOOD CORPORATION
6-17, 3-chome, Aobadai, Meguro-ku, Tokyo 153, Japan

KENWOOD ELECTRONICS, INC.
1315 E. Watsoncenter Rd, Carson, California 90745
75 Seaview Drive, Secaucus, New Jersey 07094, U.S.A.
TRIO-KENWOOD ELECTRONICS, N.V.
Leuvensesteenweg 184 B-1930 Zaventem, Belgium
TRIO-KENWOOD ELECTRONICS GmbH
Rudolf-Braas-Str. 20, 6056 Heusenstamm, West Germany
TRIO-KENWOOD FRANCE S.A.
5, Boulevard Ney, 75018 Paris, France
TRIO-KENWOOD SVENSKA AB
Kemistvagen 10A, 183 21 Taby, Sweden
TRIO-KENWOOD (AUSTRALIA) PTY. LTD.
30 Whiting St., Artarmon, N.S.W. 2064, Australia
KENWOOD & LEE ELECTRONICS, LTD.
Room 501, Wang Kee Building, 5th Floor, 34-37, Connaught Road, Central, Hong Kong

CONTENTS

EXTERNAL VIEW	3
INTERNAL VIEW	4
DISASSEMBLY FOR REPAIR	5
BLOCK DIAGRAM	6
CIRCUIT DESCRIPTION	6
DESTINATIONS' PARTS LIST	10
PARTS LIST	11
ADJUSTMENT	13
PC BOARD	13
SCHEMATIC DIAGRAM	15
SPECIFICATIONS	16

Note

The products are subject to modification in components and circuits in different countries and regions. This is because each product must be used under the best condition. This manual provides information of modification based on the standard for the convenience of ordering associated components.

USA	K
Canada	P
PX	U
Australia	X
Europe	W
England	T
Scandinavia	L
South Africa	S
Other Areas	M

EXTERNAL VIEW

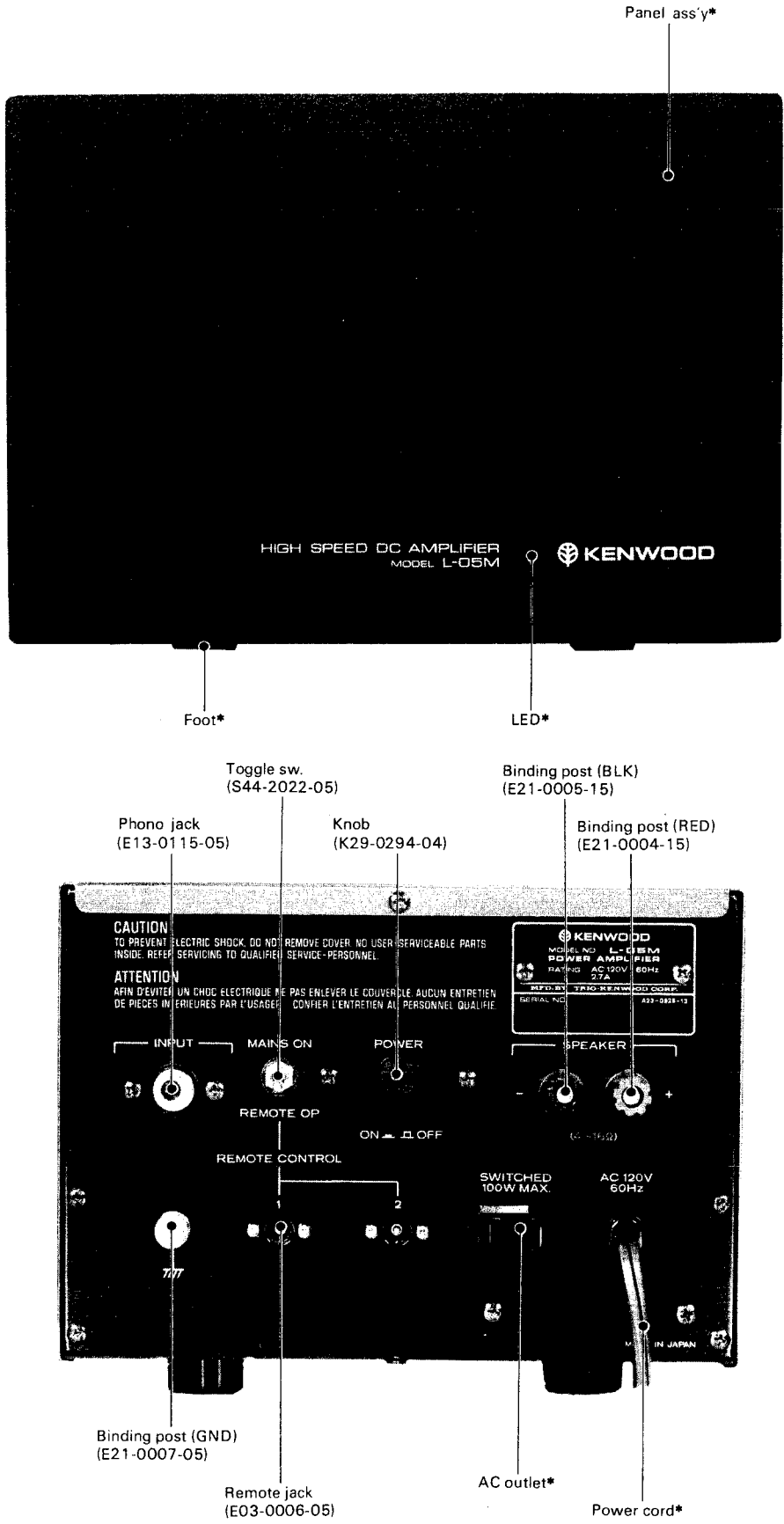

*Refer to Destinations' parts List.

INTERNAL VIEW

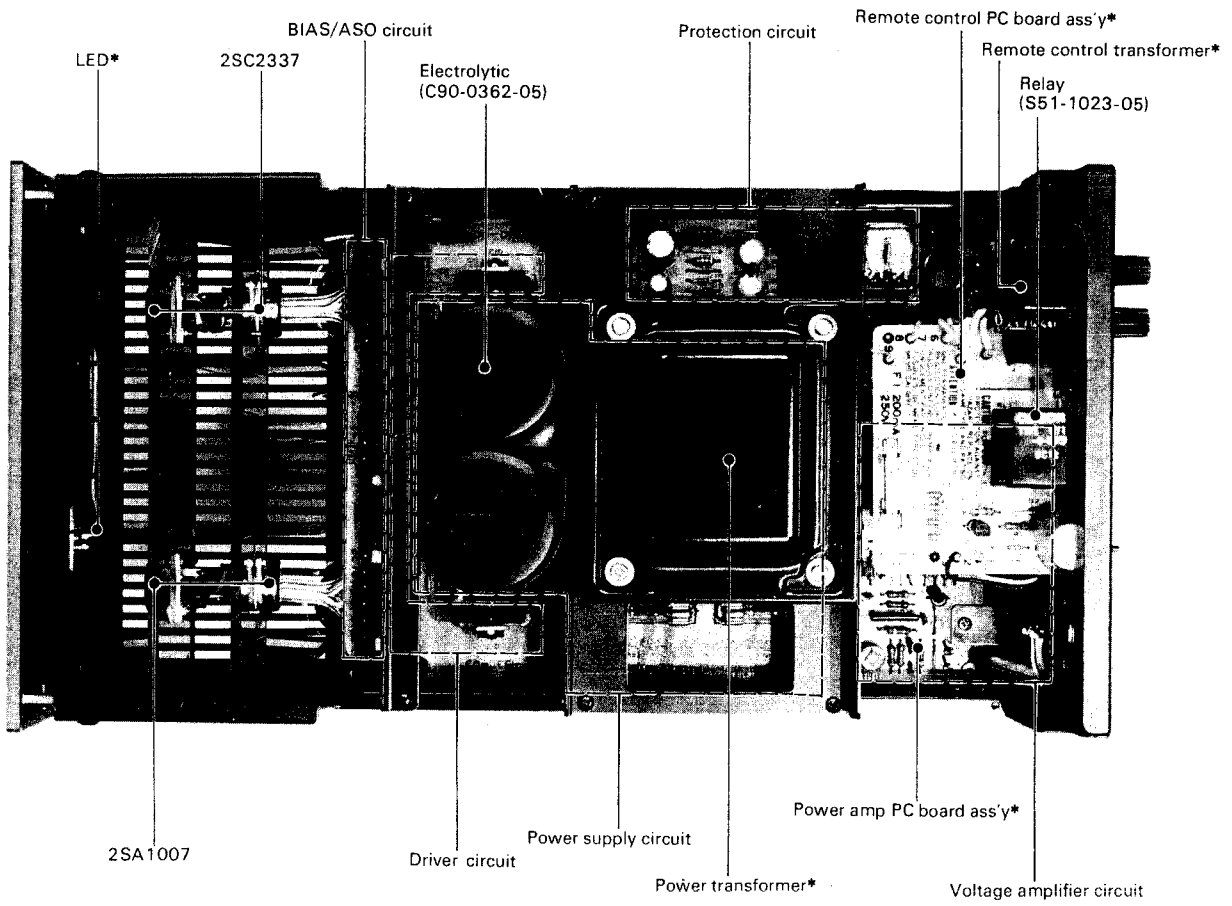

* Refer to Destinations' Parts List.

DISASSEMBLY FOR REPAIR

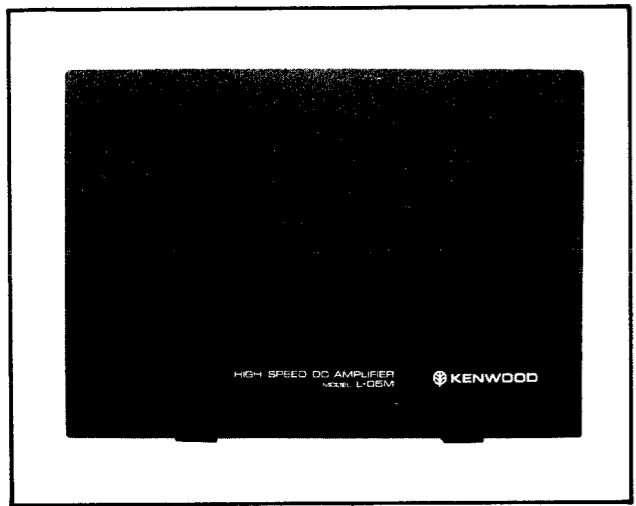

ELECTROLYTIC/DRIVER TRANSISTOR

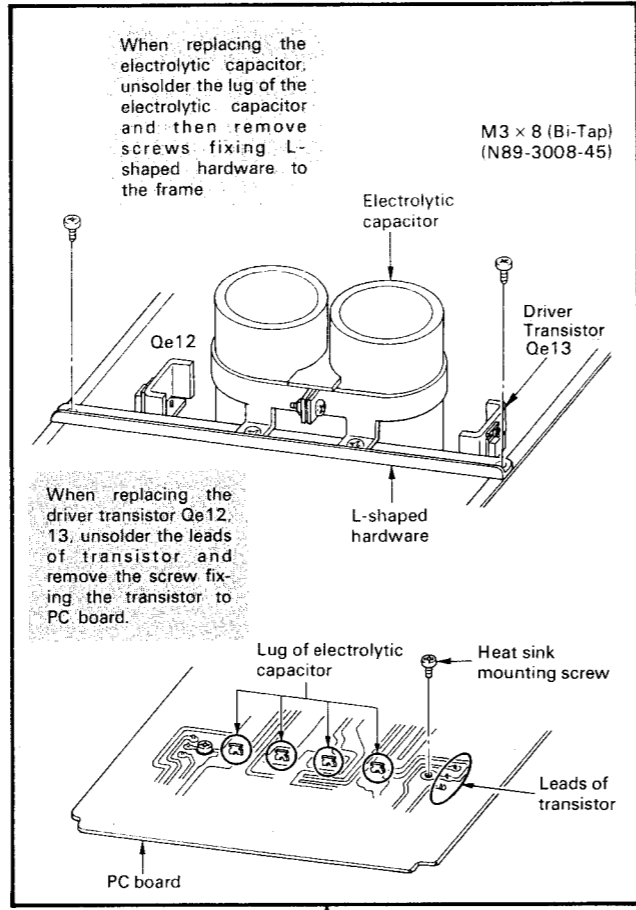

POWER TRANSISTOR (1)

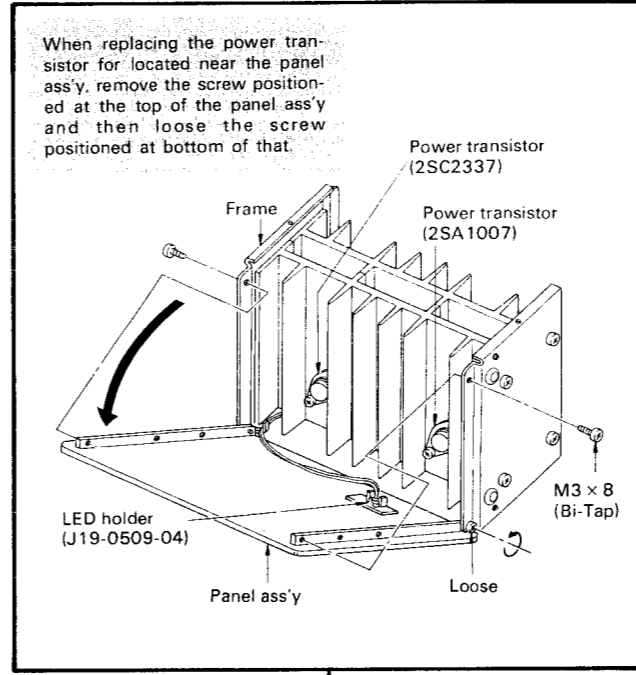

POWER TRANSISTOR (2)

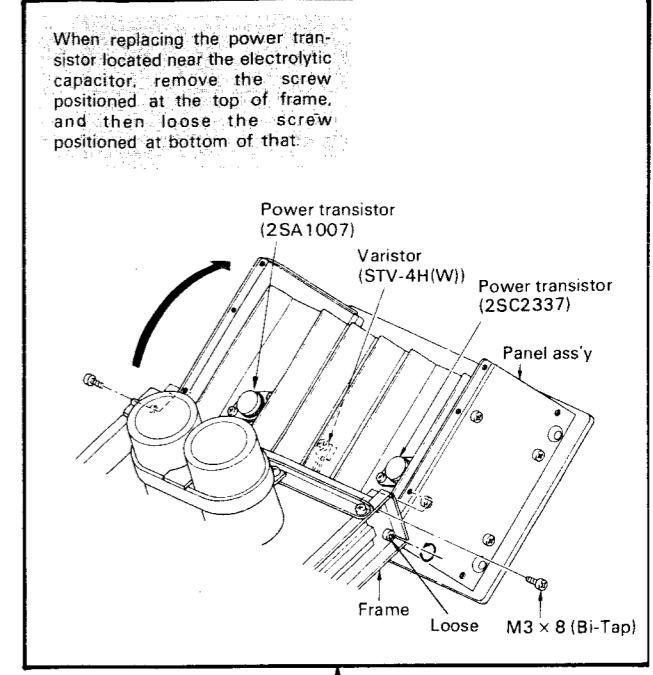

BOTTOM PLATE/CASE

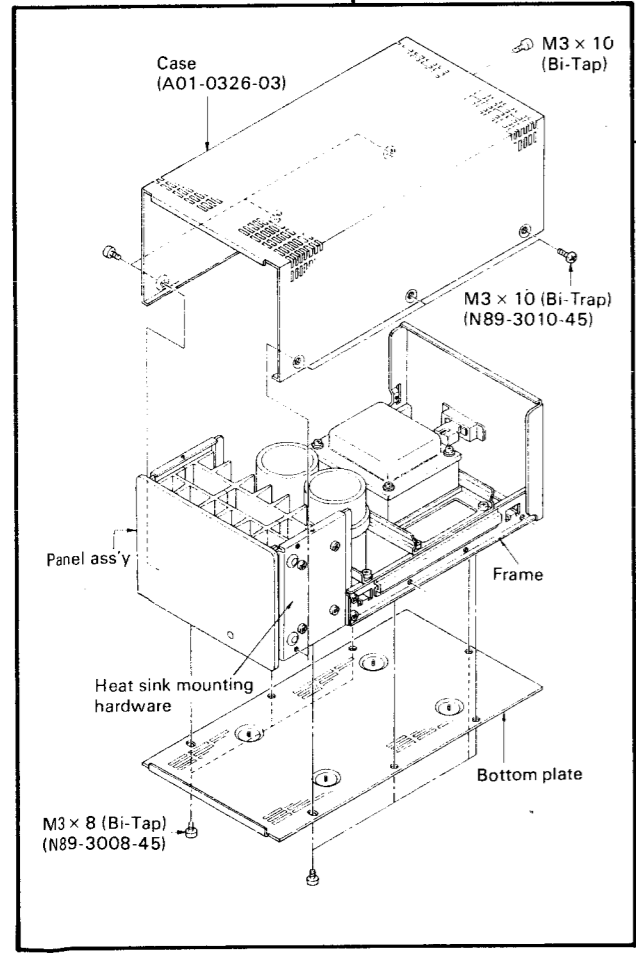

REMOTE CONTROL

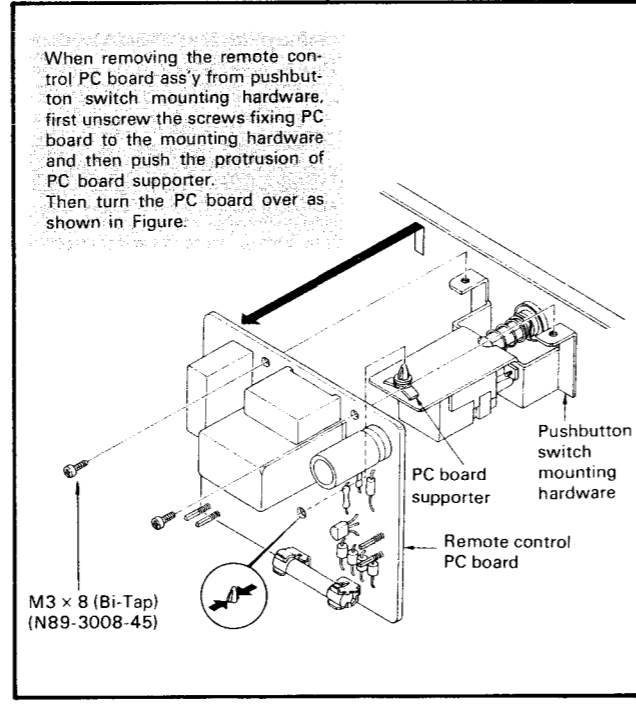

POWER TRANSFORMER

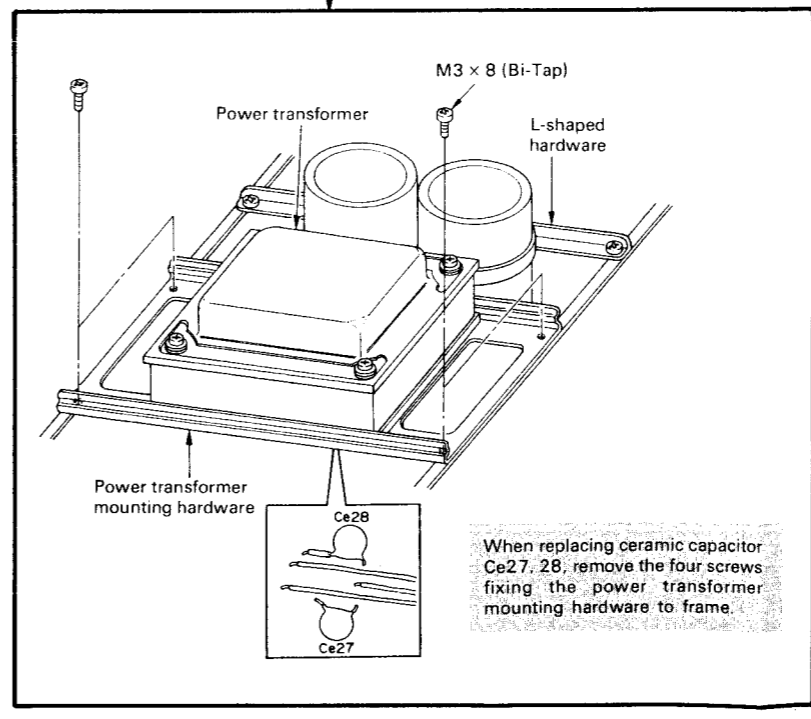

BLOCK DIAGRAM / CIRCUIT DESCRIPTION

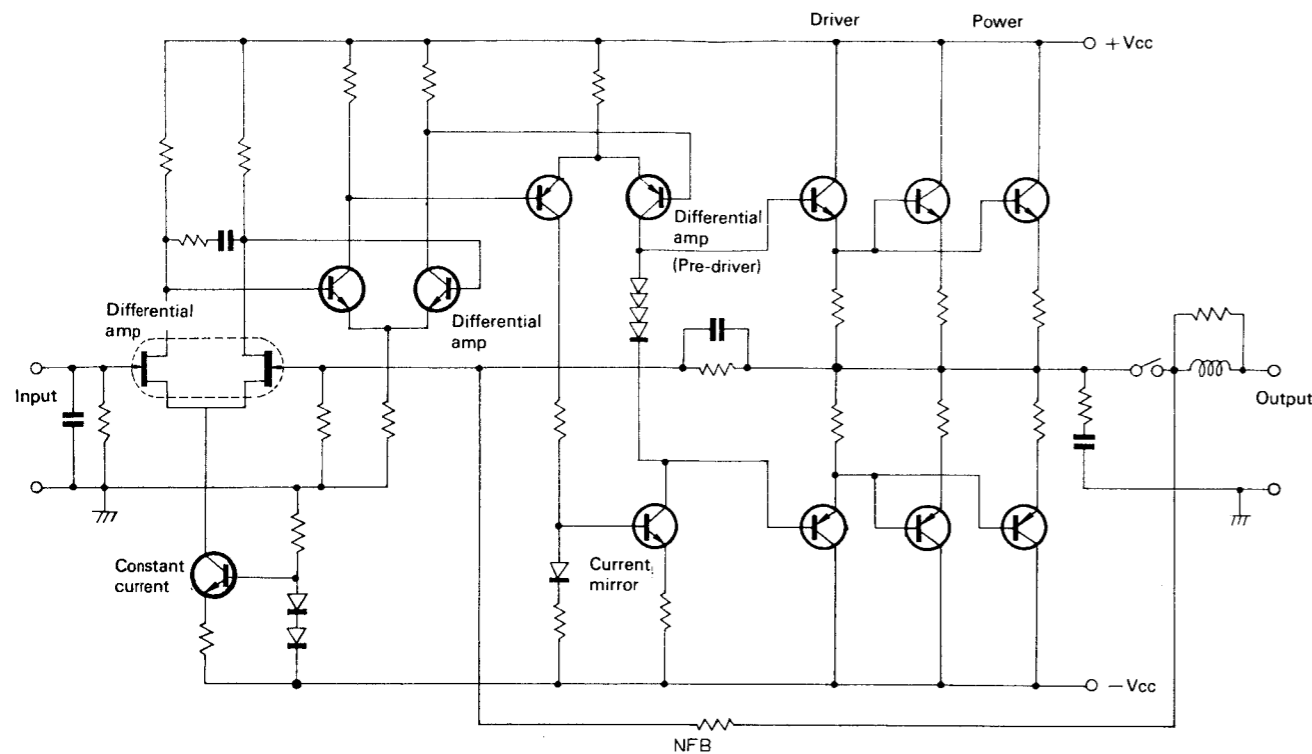

< Block Diagram of L-05M >

CIRCUIT CONFIGURATION

The voltage amplifier circuit shown in the above diagram consists of 3-stage differential amplifier, the input stage uses dual FET to suppress ΔV_{GS} and is driven by constant current to improve CMRR. Unlike AC amplifiers having time constant of low frequency range in NF loop, DC amplifier does not produce a full (100%) DC feedback and, hence, it has a problem of offset voltage due to temperature drift.

However, this amplifier incorporates highly reliable, packaged type dual FET that provides excellent thermal balance. In addition, it uses high quality, metal glazed semi-fixed resistors for adjusting offset. The offset voltage has been adjusted to zero, and its variation is as small as ± 20 mV even when the temperature of thermostatic chamber is varies from -10°C to $+60^{\circ}\text{C}$.

The amplifier also features low noise operation; the signal-to-Noise ratio is as high as 120 dB (IHF-A).

The input stage is specifically designed since the current flowing into this stage greatly affects S/N, temperature drift, slewing rate, etc.

The third stage differential amplifier employs a current mirror circuit as a load for the predriver to obtain a sufficient gain. It operates as a kind of push-pull circuit to eliminate the even-harmonics distortion. Since both the positive and negative half cycles of the signal are driven by the same impedance, the plus and minus waveforms in transient time are kept balanced, thus providing excellent output waveforms.

The current amplifier is composed of a 2-stage Darlington circuit. The output stage is connected in parallel with a well-complemented characteristic EBT to serve as a 100W monaural amplifier.

Since the signal passes through the speaker protection relay, the contacts of the relay are gold plated. This relay has 4 contacts which are connected in parallel to improve poor contact.

The L-05M contains a Multi-feedback circuit besides a common NF loop. This circuit prevents the deterioration of characteristics due to the impedance of the relay and the foil pattern.

The phase compensating coil in the output stage uses a thick and short sized wire to minimize the impedance and improve the amplifier characteristics and damping factor in high frequency range.

HIGH SPEED AMPLIFIER

In audio amplifiers, noise, harmonic distortion and cross talk must be minimized to ensure high fidelity reproduction. This can be attained by improving the circuits and electronic parts. Especially, parts layout and foil pattern techniques are important factors to determine the performance of amplifier.

CIRCUIT DESCRIPTION

The L-05M employs a special parts layout and foil pattern to completely eliminate internal channel interferences over the entire frequency range and minimize phase compensation in high-frequency range, thus assuring high gain and improving harmonic distortion even in the super high-frequency range. The transient response is also improved to minimize waveform distortion.

When a square-wave input is applied to an amplifier, the signal waveform at the output is not almost the same as the input waveform. This phenomenon is apparent especially when the input signal rises rapidly, and it is not a few found in every amplifier, even in the best type.

Accordingly, an amplifier having excellent follow-up characteristics is desirable, and such an amplifier is generally called the high speed amplifier. The follow-up ability is represented by a rise time or slewing rate. We call it "transient response" collectively.

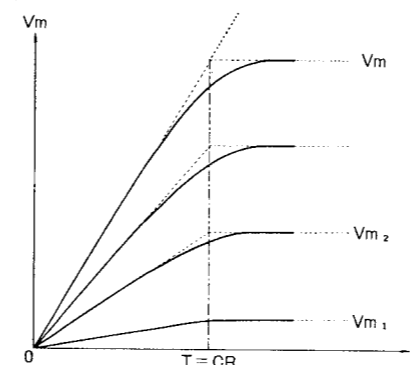

Fig. 1. Rising Characteristic of Amplifier Having Constant Rise Time

RISE TIME

If a square-wave signal is applied to an amplifier and its level is changed, a rising characteristic having a same time constant is obtained (see Fig. 1). This characteristic shows the exponential curve $V = V_m (1 - e^{-\frac{t}{T}})$ as is found when a step signal is applied to an integrating circuit. The rise time is limited by this curve since the amplifier has a time constant circuit which is related to the frequencies of small signals.

Rise Time

Before explaining the rise time for L-05M, the rising and falling characteristics of waveforms are explained below.

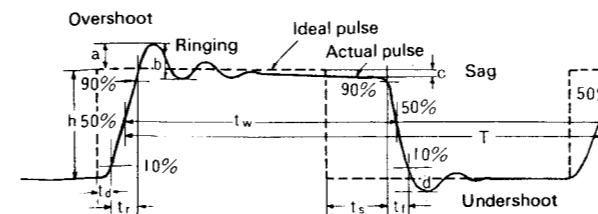

Fig. 2. Pulse Waveform

Referring to Fig. 2, the broken line shows an ideal square waveform and the solid line shows an actual pulse waveform. In the actual pulse the waveform appears later. It does not rise rapidly to the height "h" of the ideal pulse, but does not keep "h" and also rises gradually above "h" where it produces waves and then falls down below "h". Finally, the actual pulse falls gradually reaches "0" even when the ideal pulse disappears.

The process of the rising of pulse is called "rising" and that of the falling is called "falling".

Since the ideal pulse is deviated from the actual pulse, 10 ~ 90% of the height "h" of the ideal pulse is called the rising and falling characteristics.

Symbol	Item	Definition
t_d	Delay time	Time necessary for the actual pulse to rise to 10% of height "h" of the pulse. Or time from the instant at which a signal is applied to the circuit to the period at which the circuit starts operation. In other words, it is a time necessary for the pulse to pass through the circuit.
t_r	Rise time	Time necessary for the actual pulse to rise from 10% to 90% of the height "h" of the ideal pulse, or the operating speed of the circuit which is determined by frequencies.
t_s	Storage time	Time necessary for the actual pulse to fall down at 90% of the height "h" of the ideal pulse, or time at which the circuit stops operating. This is the time required to discharge the electric charge stored in a transistor.
t_f	Fall time	Time necessary for the actual pulse to fall down from 90% to 10% of the height "h" of the ideal pulse which is determined by frequencies. Since circuits have non-linear characteristic, the rising and falling characteristics require different conditions and, hence, the rise time differs from the fall time.
t_w	Half width	Pulse width used for the time at which the height "h" of the pulse is more than 50%.
a	Overshoot	A portion of waveform above the expected height "h" of one.
b	Ringing	Unstabilized portion of waveform measured between peaks. This occurs when the circuit resonates with high frequencies.
c	Sag (or zag)	A falling portion of waveform which is below the height "h" of the ideal pulse. This occurs when the circuit shuts off low frequencies and DC components.
d	Undershoot	A portion of waveform below the "0" line.

Note: The parameter of a~b is represented by % to the height "h" of waveform.

CIRCUIT DESCRIPTION

RISE TIME FOR L-05M

The rise time means the time required for the output voltage waveform to rise from 10% to 90% at 8-ohm load. In the case of audio signals, the input is not turned on and off when measuring the rise time as is done with transistors since plus and minus inputs should be taken into consideration in measurement. So, the rise time is expressed by the pulse rise time and minus rise time.

In the plus rise time (Fig. 3), if a square wave signal is applied to an integrating circuit composed of RC, the output is obtained from the following formulas:

$$V = V_m (1 - e^{-\frac{t}{CR}}) \dots (1)$$

$$V_1/V_m = 0.1 = 1 - e^{-\frac{t_1}{CR}} \dots (2)$$

V_1 is voltage at t_1 .

$$V_2/V_m = 0.9 = 1 - e^{-\frac{t_2}{CR}} \dots (3)$$

V_2 is voltage at t_2 .

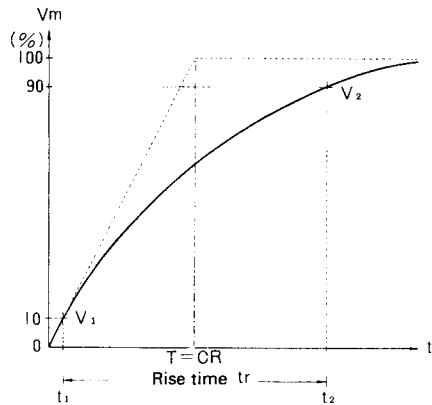

Fig. 3 Rise Time (tr)

If the rise time is expressed by "tr" ($tr = t_2 - t_1$), the following formulas are established from (2) and (3).

$$tr = 2.3 CR - 0.1 CR = 2.2 CR \dots (4)$$

$$f = 1/2\pi CR$$

$$tr = 0.35/f \dots (5)$$

The "f" is the cutoff frequency of high range determined by the time constant of CR, which is a frequency -3 dB below the frequency characteristic at a small signal.

Accordingly, the rise time can be reduced by designing the cutoff frequency of the amplifier to be high.

The cutoff frequency of L-05M is 600 kHz, so the rise time obtained from the formula (5) is 0.55 μ s.

If the input signal has a rise time of "tr1", the output of amplifier having a rise time of "tr2" becomes $tr = tr_1 + tr_2$. Therefore, accurate measurement is not possible unless the rise time "tr1" of the input signal is 1/5 to 1/10 of "tr2".

In conventional amplifiers, the plus rise time differs from the minus rise time. Generally, the rise time of these amplifiers is about 1.5 μ s to 6 μ s.

In the L-05M, the rise time in plus and minus directions are the same, providing excellent waveforms free from ringing. This amplifier is also designed for high speed operation.

Fig. 4 shows an input waveform whose rise time is as quick as 10ns and Fig. 5 shows the rising characteristic with

the input level attenuated and the output of L-05M maintained at 2 Vp-p.

The rise time was also measured at the outputs of 40 Vp-p and 80 Vp-p. In either case, the measured rise time keeps 0.55 μ s.

In other amplifiers, the rise time at the output shows 0.4 μ s but the waveform contains a ringing.

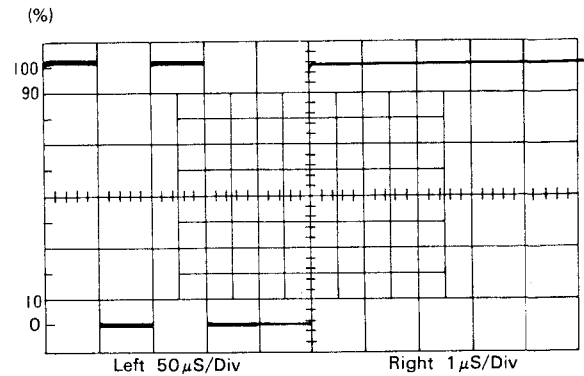

Fig. 4 Input Waveform of L-05M (Rise Time: 10nS)

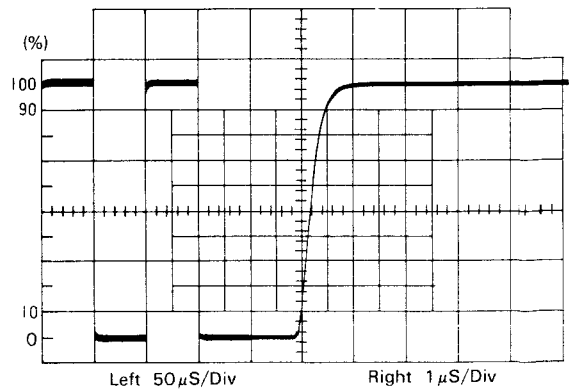

Fig. 5 Rising Characteristic of L-05M at Small Output (2 Vp-p)

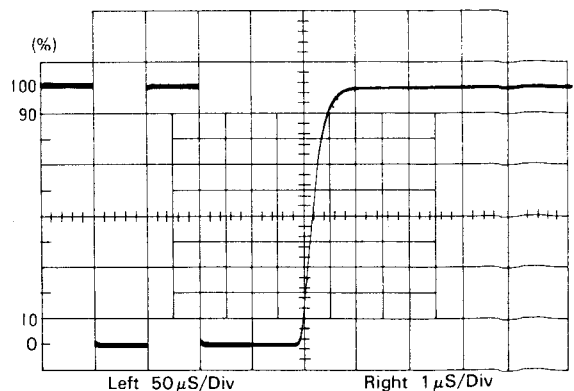

Fig. 6 Rising Characteristic of L-05M at Medium Output (40 Vp-p)

CIRCUIT DESCRIPTION

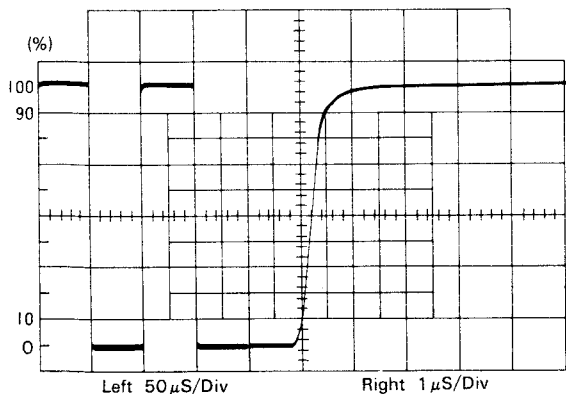

Fig. 7 Rising Characteristic of L-05M at Large Output (80 Vp-p)

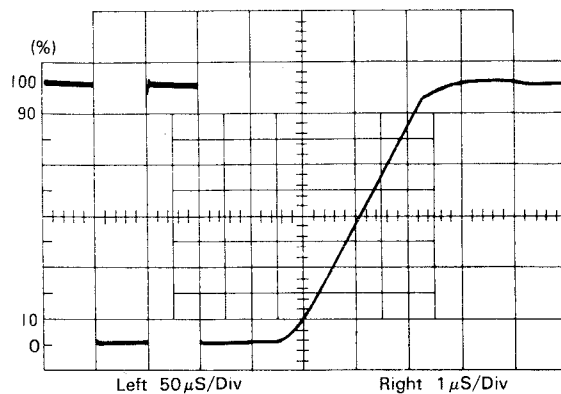

Fig. 10 Rising Characteristic of Other Wide Band Amplifiers at Large Output (80 Vp-p)

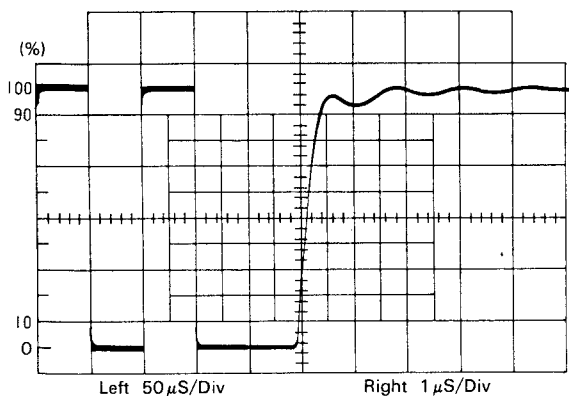

Fig. 8 Rising Characteristics of Other Wide Band Amplifiers at Small Output (2 Vp-p)

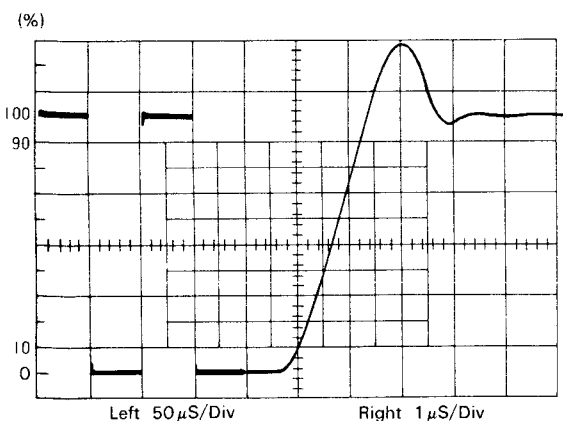

Fig. 9 Rising Characteristic of Other Wide Band Amplifiers at Medium Output (40 Vp-p)

As shown in the above figures, a large overshoot is noticed at 40 Vp-p and the rise time grows late to $1.2 \mu\text{s}$ as compared with that at 2 Vp-p.

Moreover, when the output is increased, the power voltage is saturated and the overshoot in the output is decreased, at which the rise time also grows late to $2.2 \mu\text{s}$.

The amplifiers which were tested have a short rise time at small outputs and therefore the frequency range is very wide; however, when the level is increased, the rise time is increased because it reaches rapidly the slewing rate region.

That the rise time is not varied appreciably when the input is increased until the output voltage is saturated, means that the frequency response remains the same even at a small or large amplitude. In conventional amplifiers, the cutoff frequency is introduced into low frequencies at a large amplitude and thus the rise time which is fast at a small output becomes late at a large output.

The fall of frequency response at a large amplitude depends on the slewing rate of the circuit and the high frequency characteristic of power transistors.

The L-05M uses high speed transistors (EBT) and is designed to improve the slewing rate of the circuit.

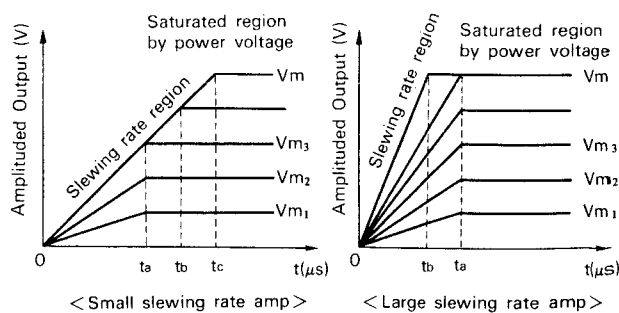

Fig. 11 The Rise Time of Amplifier with Small and Large Slewing Rate

CIRCUIT DESCRIPTION

SLEWING RATE

Both the frequency band width and the slewing rate are important factors when handling quick rising pulses and large-amplitude high frequency outputs.

When the input signal has a waveform A (Fig. 12), the output produces a waveform B which rises along a specific curve. This rise time is normally measured in $V/\mu s$.

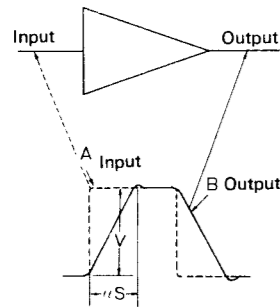

Fig. 12 Input and Output Waveforms Distortion Due to Lack of Slewing Rate

Fig. 13 shows the relationship between the gain of amplifier and frequency. With NF, the band width becomes broad but the slewing rate is reduced.

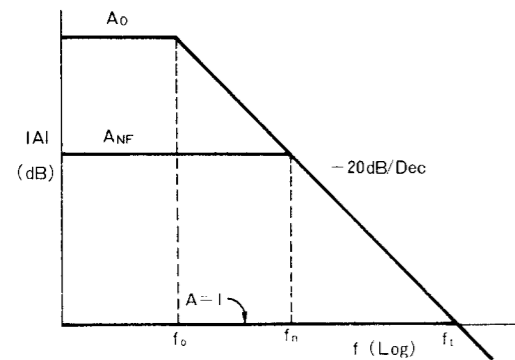

Fig. 13 Band Width Becomes Broad with NF, But....

When a square wave signal having a quick rise time is applied and the level is increased, the rise time is determined by the frequency response as explained previously.

Let the maximum inclination at $t = 0$ be θ , then the slewing rate is:

$$\tan \theta = V_m / CR$$

If a sine wave signal is applied and the output $V_o = V_m \sin \omega t$ is obtained, the maximum inclination of the sine wave is:

$$dV_o/dt = 2\pi f V_m \dots (6)$$

In this case, the inclination of the output waveform rises sharply up to the cutoff frequency but the amplitude output is reduced at frequencies above the cutoff frequency, thus the waveform is stabilized because it enters the region of slewing rate.

In the L-05M, the cutoff frequency of the maximum amplitude that maintains sine waves is the same as that of small amplitude.

The rise time is practically constant which is $t_r = 0.35/f$. Therefore, from the formula (6), the following is established:

$$SR = 2.2 V_m / t_r \dots (7)$$

V_m is saturated value of output voltage determined by power voltage.

$$SR = 2.2 \times 42 / 0.55 = 168 V/\mu s$$

In the L-05M amplifier, the circuit is designed for high speed operation and the use of high f_r power transistors of excellent switching characteristic has improved the slewing rate to $+170V/\mu s$ and $-170V/\mu s$.

It is also possible to improve the slewing rate to 300 or $400V/\mu s$, however, this causes overshoots and ringings in the output waveform. So, it is important to determine the largest possible slewing rate that causes no overshoots and ringings.

The slewing rate is determined mainly by the operating current of the voltage amplifier stage and the phase compensating capacitor.

If the power transistor has poor high frequency characteristic, it is unable to carry a sufficient current to the load at high frequencies, causing a large power loss which leads to the breakdown of the power transistor or affects the proper slewing rate.

CIRCUIT DESCRIPTION

EBT (Emitter Ballast Transistor)

EBT is a combination of small power transistors with stabilizing resistors (ballast resistor) inserted to the emitter. These transistors are excellent in high frequency characteristic and 300 cells are contained in one chip. The emitter and the stabilizing resistor are formed in the same diffusion, providing a wide safe operation range and high cutoff frequency (100 MHz) as compared with the power transistors of the same class (100W).

Features:

- (1) The emitter is divided into many sections and each section is provided with a stabilizing resistor, allowing the current to flow evenly over the entire area of the chip and also improving the breakdown strength.
- (2) The emitter and emitter stabilizing resistor are arranged for the same diffusion, so the current amplification linearity is excellent at large currents.
- (3) Outstanding NPN, PNP complementary characteristic.

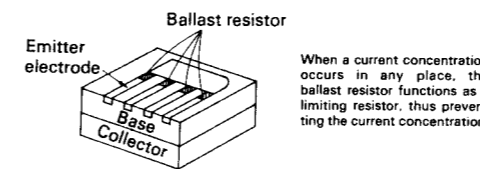

Fig. 14 Emitter with Ballast Resistor

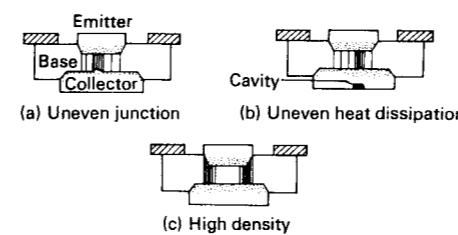

Fig. 15 Cause of Current Concentration

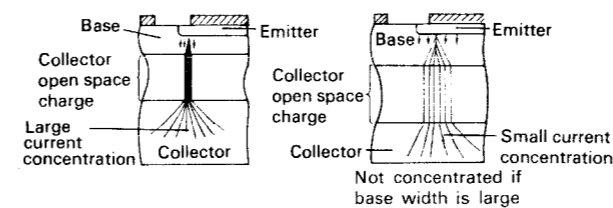

Fig. 16 Base Width, Current Connection and Diffusion Base Type

- (2) Spaces for base and collector can be reduced to provide higher cutoff frequency and smaller collector saturation voltage, if the construction breakdown strength is similar to usual ones.

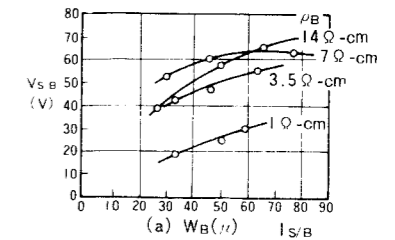
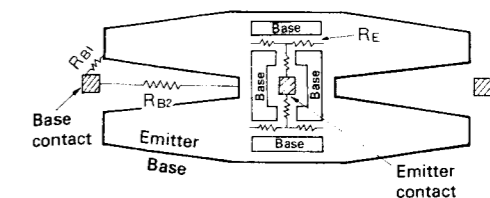
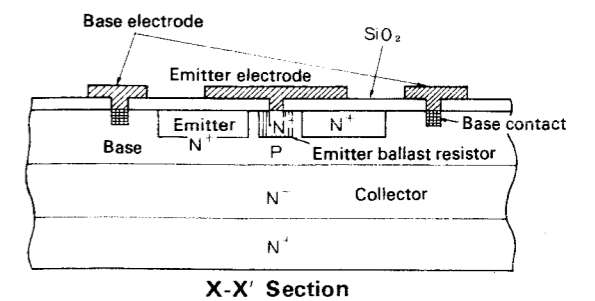
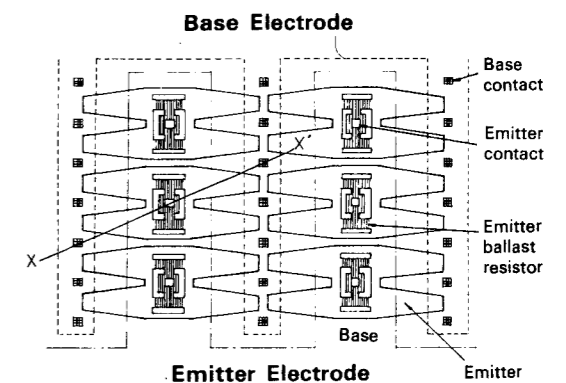

Fig. 17 Base Width and $V_{s/B}$ (Secondary Breakdown Voltage)

- (3) The emitter and emitter stabilizing resistor are arranged for the same diffusion, so the current amplification linearity is excellent at large currents.
- (4) Outstanding NPN, PNP complementary characteristic.



Current concentration will not occur between the emitter and base contacts because RB_1 is smaller than RB_2 .

RE and RB of EBT Pattern

Fig. 18 Construction of EBT

CIRCUIT DESCRIPTION

The L-05 amplifier contains differential amplifier, current mirror circuit, constant current circuit and protection circuit. For operating principles of these circuits, refer to the service manual for L-07M, L-07C and KA-8100.

- Differential amplifier..... L-07M
- Current mirror circuit..... L-07C
- Constant current circuit..... L-07M
- Protection circuit..... KA-8100

DESTINATIONS' PARTS LIST

☆ : New Parts

Ref. No.	U.S.A. (K)	Canada (P)	PX (U)	Australia (X)	Europe (W)	Scandinavia (L)	England (T)	South Africa (S)	Other Area (M)	Description
	A20-1213-03	A20-1213-03	A20-1213-03	A20-1213-03	A20-1213-03	A20-1213-03	A03-1322-03	A03-1213-03	A03-1213-03	Panel ass'y ☆
D2	B30-0139-05	B30-0139-05	B30-0139-05	B30-0139-05	B30-0139-05	B30-0151-05	B30-0139-05	B30-0139-05	B30-0139-05	LED ☆
	B46-0061-01	B46-0055-20	B46-0062-10	B46-0084-00			B46-0060-00			Warranty card
			B46-0063-00							Warranty card
	B50-1672-00	B50-1673-00	B50-1672-00	B50-1672-00	B50-1672-00	B50-1672-00	B50-1674-00	B50-1672-00	B50-1673-00	Instruction manual ☆
			B59-0018-00							KENWOOD service stations' list
			D32-0081-04	D32-0081-04	D32-0081-04	D32-0081-04		D32-0081-04	D32-0081-04	Switch stopper
	E03-0008-05									AC outlet
	E30-0181-05			E30-0185-05	E30-0560-05	E30-0292-05	E30-0602-05	B30-0602-05	E30-0515-05	Power Cord
	E30-0600-15			E30-0595-15	E30-0595-15	E30-0595-15	E30-0595-15	E30-0595-15	E30-0595-15	Speaker cord
										Carton box ☆
	J02-0073-04	J02-0049-14	J02-0049-14	J02-0049-14	J02-0049-14	J02-0049-14	J02-0049-14	J02-0049-14	J02-0049-14	Foot
	J41-0034-05	J41-0034-05	J41-0033-05	J41-0024-15	J41-0033-05	J41-0033-05	J41-0024-15	J41-0024-15	J41-0033-05	Cord bushing
	L01-1431-05	L01-1431-05	L01-1435-05	L01-1435-05	L01-1436-05	L01-1436-05	L01-1437-05	L01-1435-05	L01-1435-05	Power transformer ☆
	L01-1521-05	L01-1521-05	L01-1526-05	L01-1526-05	L01-1526-05	L01-1526-05	L01-1526-05	L01-1526-05	L01-1526-05	Remote control power transformer ☆
S2			S31-3004-05	S31-3004-05	S31-3004-05	S31-3004-05		S31-3004-05	S31-3004-05	Slide switch (power voltage selector)
	X07-1590-11	X07-1590-11	X07-1590-00	X07-1590-00	X07-1590-61	X07-1590-61	X07-1590-61	X07-1590-00	X07-1590-00	Power amp PC board ass'y ☆
	X13-2530-11	X13-2530-11	X13-2530-21	X13-2530-21	X13-2530-61	X13-2531-71	X13-2530-61	X13-2530-21	X13-2530-21	Remote control PC board ass'y ☆

PARTS LIST

RS: Metal film resistor
RD: Carbon film resistor

☆: New Parts

Ref. No.	Parts No.	Description	Re- marks
CAPACITORS			
C1	C90-0362-05	Electrolytic 12000 μ F 79VS	☆
SEMICONDUCTOR			
Q1,2	V03-2337-00	Transistor 2SC2337	☆
Q3,4	V01-1007-00	Transistor 2SA1007	☆
D1	V11-5100-10	Varistor STV-4H (W)	
SWITCH			
S3	S44-2022-05	Toggle (REMOVE)	
MISCELLANEOUS			
—	A01-0345-03	Case	
—	B07-0111-04	Ring	☆
—	B42-0009-04	Passed sticker	
—	E02-0209-05	Transistor socket \times 4	
—	E03-0006-05	Remote jack	
—	E13-0115-15	Phono jack with lock	
—	E21-0004-15	Binding post (RED)	
—	E21-0005-15	Binding post (BLK)	
—	E21-0007-05	Binding post (GND)	☆
—	E30-0594-05	Remote cord ass'y	
—	H10-1510-02	Polystyrene foamed fixture (R)	☆
—	H10-1511-02	Polystyrene foamed fixture (L)	☆
—	H25-0078-00	Instruction bag \times 2	
—	J19-0509-04	LED holder	
—	J25-1534-14	Power line PC board	☆
—	K29-0292-04	Knob	☆

POWER AMP (X07-1590-11)

Ref. No.	Parts No.	Description	Re- marks
CAPACITOR			
Ce1	CC45SL1H470K	Ceramic 47pF \pm 10%	
Ce2	CC45SL1H101K	Ceramic 100pF \pm 10%	
Ce3	CE04W1V101EL	Electrolytic 100 μ F 35WV	
Ce4	CK45B1H821K	Ceramic 820pF \pm 10%	
Ce5	CC45SL1H030D	Ceramic 3pF \pm 0.5pF	
Ce6	CE04W0J471JL	Electrolytic 470 μ F 6.3WV	
Ce7	CC45SL1H470K	Ceramic 47pF \pm 10%	
Ce8	CE04W2A101EL	Electrolytic 100 μ F 100WV	
Ce9	CC45SL1H470K	Ceramic 47pF \pm 10%	
Ce10	CC45SL1H330K	Ceramic 33pF \pm 10%	
Ce11,12	CE04W2A101EL	Electrolytic 100 μ F 100WV	
Ce13	CE04W1H010EL	Electrolytic 1 μ F 50WV	
Ce14	CC45SL1H080D	Ceramic 8pF \pm 0.5pF	
Ce15	CC45SL1H020D	Ceramic 2pF \pm 0.5pF	
Ce16	CQ93M1H103M	Mylar 0.01 μ F \pm 20%	
Ce17	CC45SL1H271K	Ceramic 270pF \pm 10%	
Ce18	CE04W1A470EL	Electrolytic 47 μ F 10WV	
Ce19	CC45SL1H120K	Ceramic 12pF \pm 10%	
Ce20,21	CE04W1E100EL	Electrolytic 10 μ F 25WV	
Ce22	CE04W1A470EL	Electrolytic 47 μ F 10WV	
Ce23	CE04W1C470EL	Electrolytic 47 μ F 16WV	
Ce27,28	CK45E2H103P	Ceramic 0.01 μ F \pm 100%—0%	
Ce29	CE04W1H100EL	Electrolytic 10 μ F 50WV	
Ce30,31	CE04W1C101EL	Electrolytic 100 μ F 16WV	
Ce32	CE04AW1E470EL	Electrolytic 47 μ F 25WV	
Ce33	CQ93M1H473M	Mylar 0.047 μ F \pm 20%	

Ref. No.	Parts No.	Description	Re- marks
RESISTOR			
Re7,8	RD14GY2E101JMA	Flame proof RD 100 Ω \pm 5% 1/4W	
Re10	RD14GY2E391JMA	Flame proof RD 390 Ω \pm 5% 1/4W	
Re11	RS14GB3A332JMA	Flame proof RS 3.3k Ω \pm 5% 1W	
Re12,13	RD14GY2E911JMA	Flame proof RD 910 Ω \pm 5% 1/4W	
Re17	RD14GY2E101JMA	Flame proof RD 100 Ω \pm 5% 1/4W	
Re18	RS14GB3A682JMA	Flame proof RS 6.8k Ω \pm 5% 1W	
Re19,20	RD14GY2E221JMA	Flame proof RD 220 Ω \pm 5% 1/4W	
Re21,22	RD14GY2E270JMA	Flame proof RD 27 Ω \pm 5% 1/4W	
Re23,24	RN92BC2E223F	Metal film 22k Ω \pm 1% 1/4W	
Re25	RD14GY2E390JMA	Flame proof RD 39 Ω \pm 5% 1/4W	
Re30,32	RD14GY2E620JMA	Flame proof RD 62 Ω \pm 5% 1/4W	
Re33~36	R92-0111-05	Metal film 0.47 Ω \pm 5% 3W	
Re37~40	RD14GY2E4R7JMA	Flame proof RD 4.7 Ω \pm 5% 1/4W	
Re44	RS14GB3A102JMA	Flame proof RS 1k Ω \pm 5% 1W	
Re45	RS14GB3A272JMA	Flame proof RS 2.7k Ω \pm 5% 1W	
Re46	RS14GB3A472JMA	Flame proof RS 4.7k Ω \pm 5% 1W	
Re54,55	RS14GB3D471JMA	Flame proof RS 470 Ω \pm 5% 2W	
Re57	RS14GB3A4R7JMA	Flame proof RS 4.7 Ω \pm 5% 1W	
Re58,59	RS14FB3F100JMA	Flame proof RS 10 Ω \pm 5% 3W	
SEMICONDUCTOR			
Qe1	V09-0129-10	Dual FET 2SK109(D), (E)	☆
Qe2~4	V03-0500-05	Transistor 2SC1775(E), (F)	
Qe5,6	V01-0199-05	Transistor 2SA899(B), (V)	
Qe7	V03-0460-05	Transistor 2SC1904(B), (V)	
Qe8	V01-0191-05	Transistor 2SA872(D), (E)	
Qe9,10	V03-0500-05	Transistor 2SC1775(E), (F)	
Qe11	V01-0191-05	Transistor 2SA872(D), (E)	
Qe12	V03-0408-05	Transistor 2SC1913(Q), (R)	
Qe13	V01-0188-05	Transistor 2SA913(Q), (R)	
Qe14	V03-0408-05	Transistor 2SC1222(E), (U)	
Qe15	V03-0424-05	Transistor 2SC1400(E), (U)	
Qe16	V03-0452-05	Transistor 2SC1735(D), (E)	
De1	V11-0435-05	Zener diode EQA01-24R	
De2~4	V11-0271-05	Diode 1S2076	
De7,8	V11-0273-05	Diode 1S2076A	
De9	V11-0271-05	Diode 1S2076	
De10~13	V11-7100-40	Diode ERD03-02H	☆
De14,15	V11-0295-05	Diode W06B	
De16	V11-0273-05	Diode 1S2076A	
De17~20	V11-0271-05	Diode 1S2076	
De21	V11-0295-05	Diode W06B	
COIL			
Le1	L40-1001-05	Phase compensation	
Le2,3	L39-0082-05	Ferri-inductor	☆
POTENTIOMETER			
VR31,2	R12-0502-05	Trimming metal glase 100 Ω (B) OFFSET, BIAS	
RELAY			
RLe1	S51-4030-05	Relay (24V)	
MISCELLANEOUS			
Fe1,2	F05-5022-05	Fuse (5A) (X07-1590-00)	
	F05-5021-05	Fuse (5A) (X07-1590-11)	
	F05-5024-05	Fuse (5A) (X07-1590-61)	
	J13-0041-05	Fuse clip \times 4 (X07-1590-11)	
	J13-0054-05	Fuse clip \times 4	

PARTS LIST

REMOTE CONTROL (X13-2530-11)

Ref. No.	Parts No.	Description	Re- marks
CAPACITOR			
Ch1	CE04W1C102EL	Electrolytic 1000 μ F 16WV	
Ch2,3	C91-0025-05	Film 0.01 μ F AC 125V (X13-2530-11)	
	C91-0023-05	Film 0.01 μ F AC 125V (X13-2530-21)	
	CK45E3D103PMU	Ceramic 0.01 μ F DC 2kV (X13-2530-61, -2531-71)	
Ch4	C91-0310-05	Metal film 0.1 μ F 1000V (X13-2530-21)	
	C90-0151-05	Metal film 0.047 μ F 250V (X13-2530-61, -2531-71)	
Ch5	C91-0025-05	Film 0.01 μ F AC 125V (X13-2530-11)	
	C91-0023-05	Film 0.01 μ F AC 125V (X13-2530-21)	
Ch5.6	CK45E3D103PMU	Ceramic 0.01 μ F DC 2kV (X13-2530-61, -2531-71)	
SEMICONDUCTOR			
Qh1	V01-0130-05	Transistor 2SA684(Q), (R)	
Dh1	V11-0271-05	Diode 1S2076	
Dh2~6	V11-0295-05	Diode W06B	
SWITCH/RELAY			
S1	S40-2085-05	Pushbutton (POWER) (X13-2530-11)	
	S40-2074-05	Pushbutton (POWER) (X13-2530-21)	
	S40-2075-05	Pushbutton (POWER) (X13-2530-61, -2531-71)	
RELAY			
RL1	S51-1023-05	Relay	☆
MISCELLANEOUS			
F1	F05-3014-05	Fuse (0.3A) (X13-2530-11)	
	F05-3011-05	Fuse (0.3A) (X13-2530-21)	
	F05-3112-05	Fuse (315mA) (X13-2530-61, -2531-71)	
—	J13-0055-05	Fuse clip \times 2	

NOTE: PC board ass'y numbered X13-2531-71 is provided with Rh3.

Note:

Resistors except the special type (example: cement, metal film, etc.) are not detailed in PARTS LIST. With regard to the value, refer to the schematic diagram or the PC board illustration.

Resistors not detailed are carbon type (1/4W or 1/8W).

You should give an order for the carbon resistors according to the ways described as follows:

A carbon resistor's part number is example RD14BY 2E 222J

1. Kinds of the carbon resistor

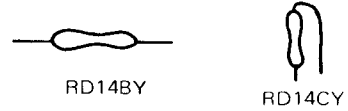

2. Wattage

1/4W \rightarrow 2E
1/8W \rightarrow 2B

3. Resistance value

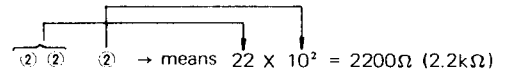

Significant figure Multiplier

Example:

221 \rightarrow 220 Ω
222 \rightarrow 2.2k Ω
223 \rightarrow 22k Ω
224 \rightarrow 220k Ω
225 \rightarrow 2.2M Ω

4. Tolerance

J = \pm 5% (Gold color)
K = \pm 10% (Silver color)

ADJUSTMENT

OFFSET ADJUSTMENT

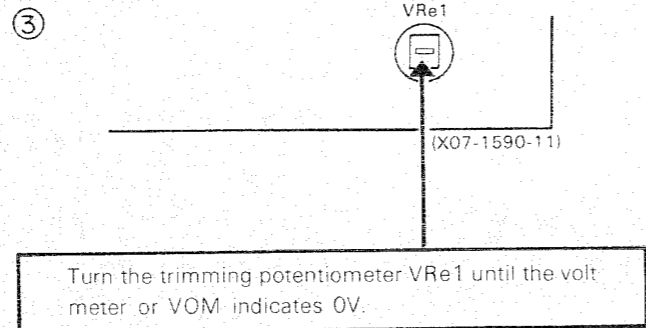
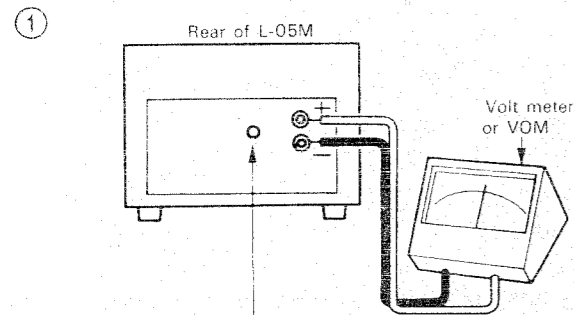

Note: If the output terminal has DC voltage more than specified value, protection circuit works. Whenever adjusting OFFSET, check whether the relay works or not.

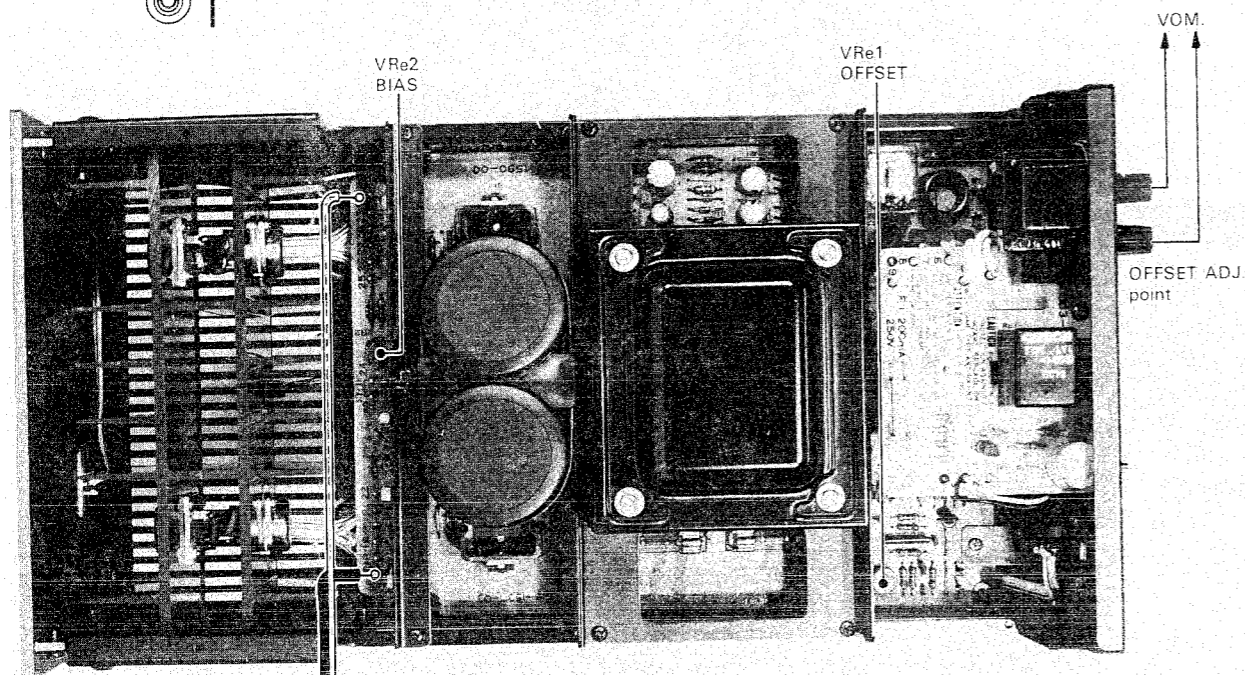

BIAS CURRENT

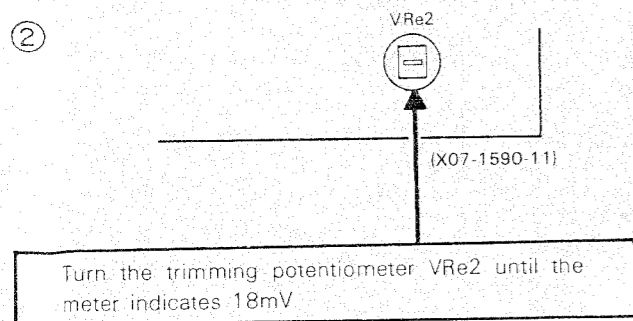
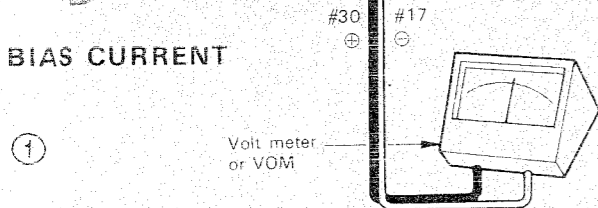

PC BOARD

REMOTE (X13-2530-11)

Note: Only PC board ass'y numbered X13-2531-71 is provided with Rh3. Measured DC voltage is across #2 of X13-2530-11.

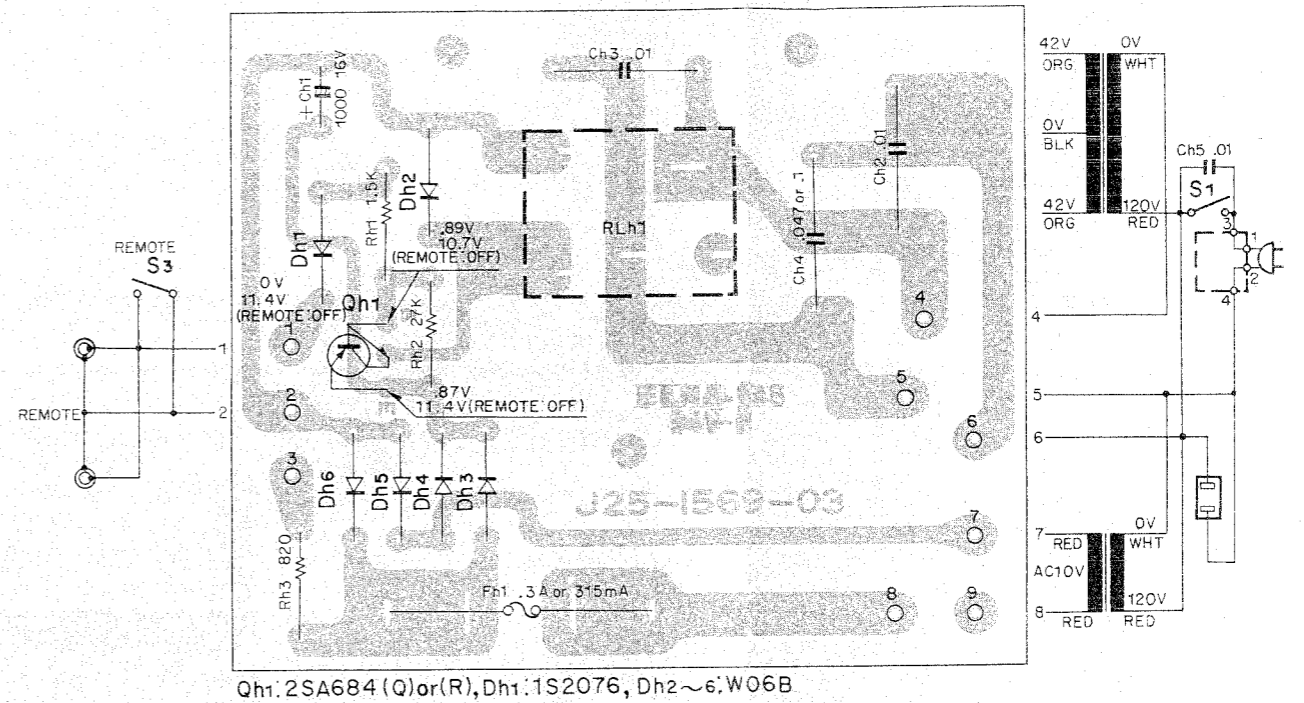

Qh1: 2SA684 (Q) or (R), Dh1: 1S2076, Dh2~6: W06B

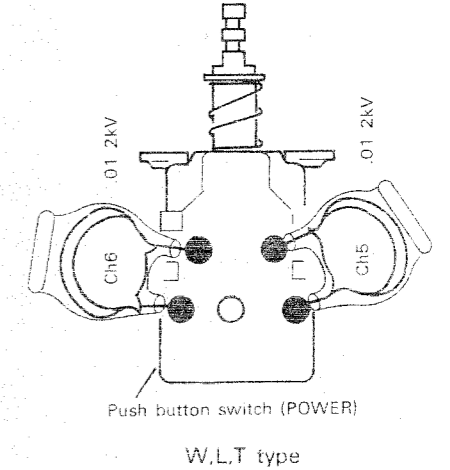
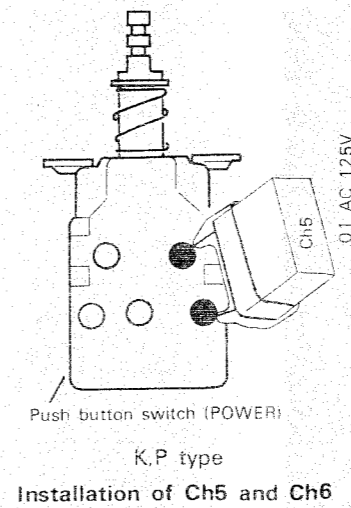
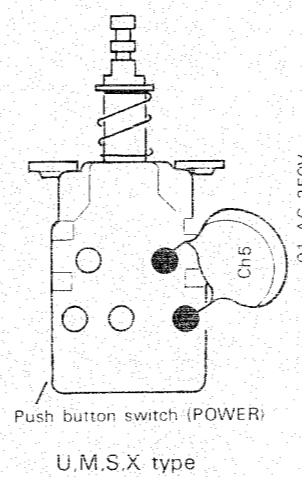

ABSOLUTE MAX. RATINGS

TRANSISTOR	VCBO	VEBO	VCEO	IC	PT	Tj	Tstg	fT
2SA1007	-150V	-4.5V	-130V	-10A	4W (Ta=24°C) 100W (Tc=25°C)	150°C	-65~+150°C	50 MHz
2SC2337	150V	4.5V	130V	10A	5W (Ta=25°C) 100W (Tc=25°C)	150°C	-65~+150°C	70 MHz
FET	VGDO	ID	PT	Tch				
2SK109	-50V	20 mA	150 mW	+125°C				

PC BOARD

- Vcc + Vcc

POWER AMP (X07-1590-11)

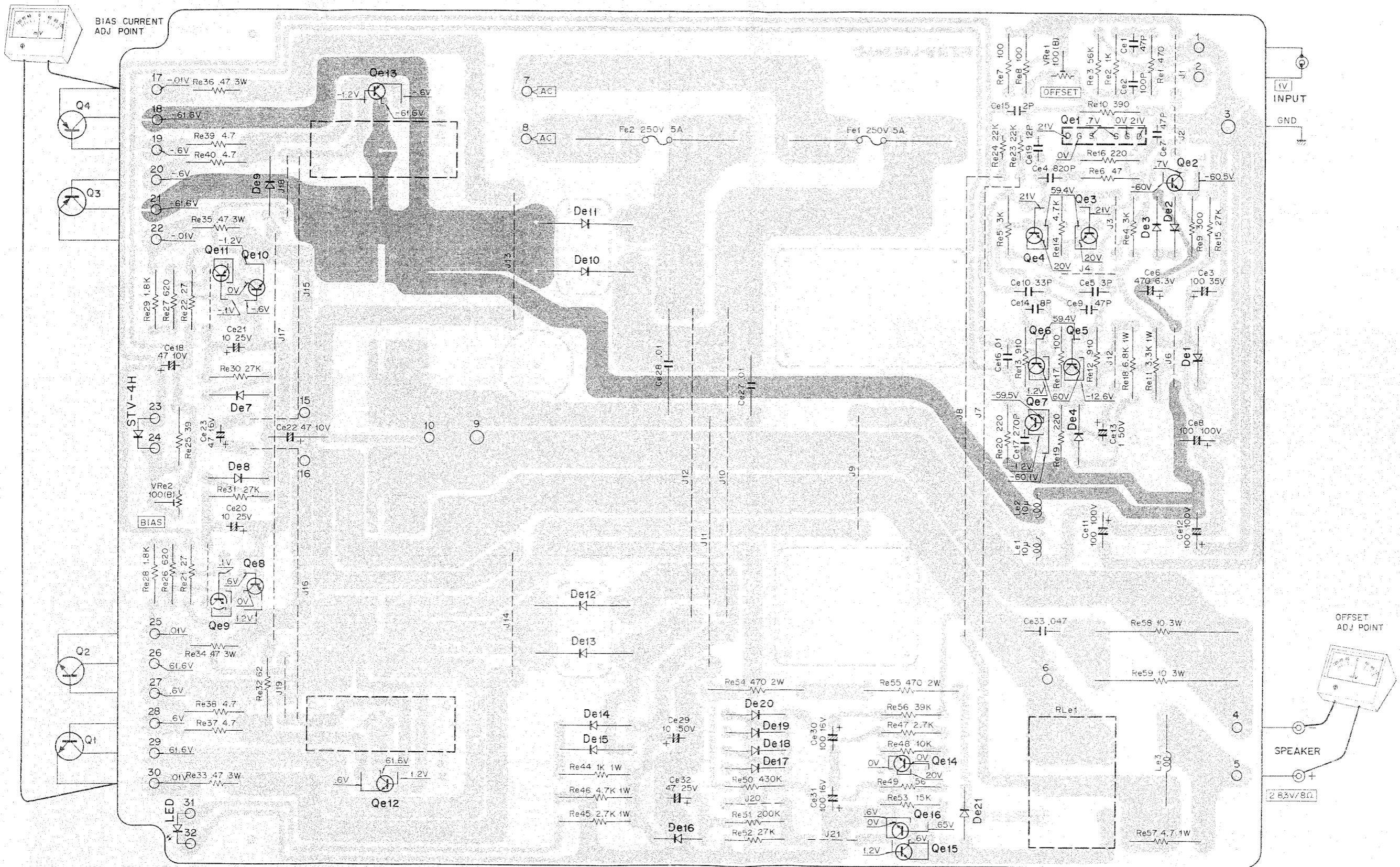

Qe1: 2SK109 (D) or (E), Qe2~4, 9, 10: 2SC1775 (E) or (F), Qe5, 6: 2SA899 (B) or (V), Qe7: 2SC1904 (B) or (V), Qe8, 11: 2SA872 (D) or (E), Qe12: 2SC1913 (Q) or (R), Qe13: 2SA913 (Q) or (R)
 Qe14: 2SC1222 (E) or (U), Qe15: 2SC1400 (E) or (U), Qe16: 2SC1735 (D) or (E), De1: EQA01-24R, De2~4, 9, 17~20: 1S2076, De7, 8, 16: 1S2076A, De10~13: ERD03-02H, De14, 15, 21: WO6B

SCHEMATIC DIAGRAM

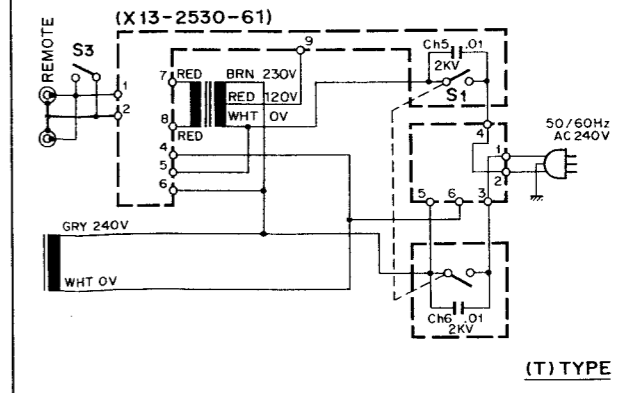
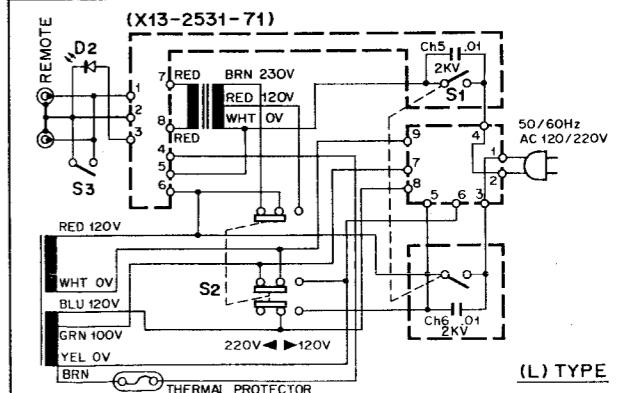
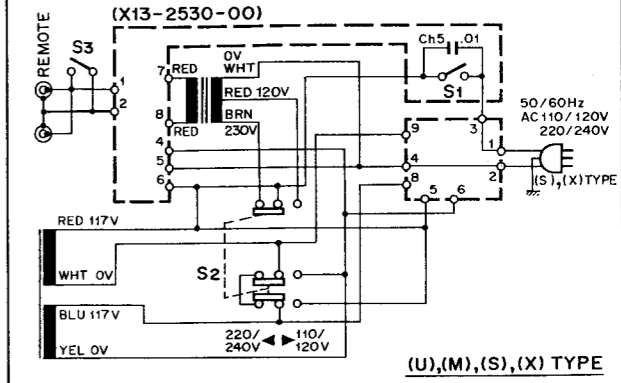
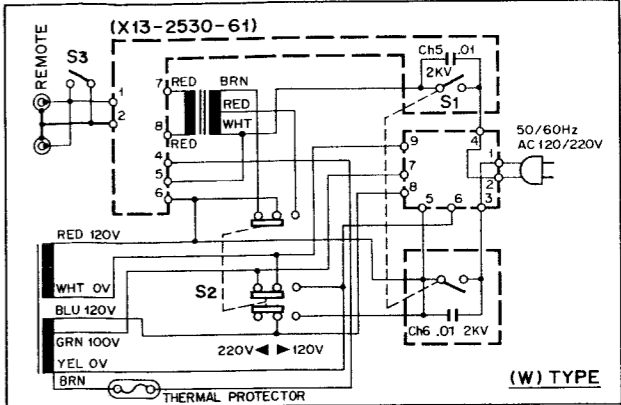
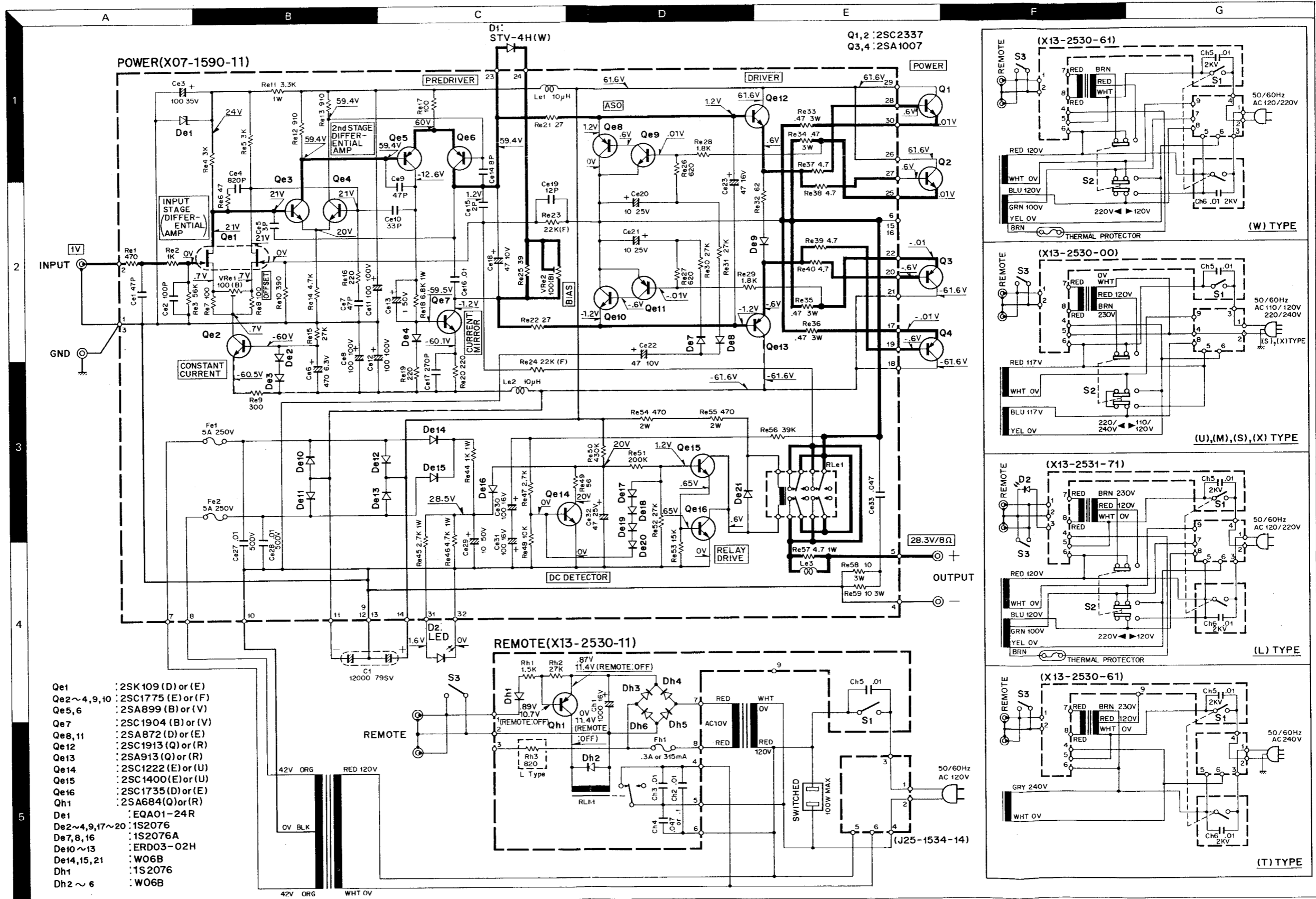

- Qe1 : 2SK 109 (D) or (E)
- Qe2~4,9,10 : 2SC1775 (E) or (F)
- Qe5,6 : 2SA899 (B) or (V)
- Qe7 : 2SC1904 (B) or (V)
- Qe8,11 : 2SA872 (D) or (E)
- Qe12 : 2SC1913 (Q) or (R)
- Qe13 : 2SA913 (Q) or (R)
- Qe14 : 2SC1222 (E) or (U)
- Qe15 : 2SC1400 (E) or (U)
- Qe16 : 2SC1735 (D) or (E)
- Qh1 : 2SA684 (Q) or (R)
- De1 : 1S2076
- De2~4,9,17~20 : 1S2076
- De7,8,16 : 1S2076A
- De10~13 : ERD03-02H
- De14,15,21 : W06B
- Dh1 : 1S2076
- Dh2~6 : W06B

Semiconductor	Substitutions
2SA1007 2SC2337	—
2SA872(D),(E) 2SA899(B),(V) 2SC1222(E),(U)	Qe8,11 (limiter) = 2SA733 2SC1775, 2SC1681 2SC1400, 2SC2089 2SC1980 or (VCE0 ≥ 60V) 2SC1775, 2SC1980, 2SC2089
2SC1400(E),(U)	or (VCE0 ≥ 80V, ICBO: Small hFE: High 2SC1567 or VCE0 ≥ 80V Ic > 100mA
2SC1735(D),(E)	Qe9,10 (limiter) = 2SC945
2SC1775(E),(F) SC1904(B),(V) 2SC1913(Q),(R) 2SK109(D),(E)	— — — —

NOTE:

1. Resistor values are indicated in ohm (K: 1000-ohms, M: 1000k ohms). Non specified resistors are 1/4W, and ±5%.
2. Capacitor values are in μF (1P = μμF = pF = 10⁻¹² × F, μF 10⁻⁶ × F) Non specified capacitors are 50WV.
3. Inductance values are in Henry.
4. DC voltages are measured with 20kΩ/V VOM at no signal between GND.
5. DC voltage of REMOTE PC board ass'y is measured between #2 of X13-2530-11.

In the case of using the substitutive semiconductor, you should confirm the leads of one.

SPECIFICATIONS

Specifications described here are based on the measurement using the special speaker cable with length of one meter provided.

PERFORMANCE

100 watts* minimum RMS at 8 ohms, from 20 Hz to 20,000 Hz with no more than 0.005% total harmonic distortion.

Continuous Power

8 ohms at 1,000 Hz	100 watts
4 ohms at 1,000 Hz	150 Watts

Total Harmonic Distortion

10 Hz ~ 100 kHz, 8 ohms at rated power	0.06%
20 Hz ~ 20 kHz, 8 ohms at rated power	0.005%
20 Hz ~ 20 kHz, 8 ohms at 1/10 rated power	0.0035%
1 kHz, 8 ohms at rated power	0.0015%
1 kHz, 4 ohms at rated power	0.004%

Intermodulation Distortion

(60 Hz : 7 kHz = 4 : 1)

8 ohms at rated power	0.001%
8 ohms at 1/10 rated power	0.001%
4 ohms at rated power	0.03%

Frequency Response DC~600 kHz +0, -3 dB

Signal to Noise Ratio (short-circuited) 120 dB

Damping Factor

DC~20 kHz, 8 ohms	150
DC~20 kHz, 8 ohms without speaker cable	200
DC~80 kHz, 8 ohms without speaker cable	100

Input Sensitivity/Impedance 1V/50k ohms

Transient Response

Rise Time -1V ⇄ +1V	0.55μS
-20V ⇄ +20V	0.55μS
-40V ⇄ +40V	0.55μS

Slew Rate ±170V/μS

Speaker Impedance Accept 4 ohms to 16 ohms speaker impedance

Speaker Cable Loss 0.01 ohm

GENERAL

Power Requirements 60 Hz 120V (U.S. A. and CANADA Model) or
50/60 Hz 110-120V/220-240V

Power Consumption at full power 600 watts
at non-signal 30 watts

AC Outlet 1 UNSWITCHED

Dimensions W: 7-7/8" (200mm)
H: 6-3/32" (155 mm)
D: 15-11/32" (390mm)

Weight Net 19.2 lbs (8.7 kg)
Gross 21.6 lbs (9.8 kg)

* Measured pursuant to Federal Trade Commission's Trade Regulation rule on Power Output Claims for Amplifier in U.S.A.

Note:

Kenwood follows a policy of continuous advancements in development. For this reason specifications may be changed without notice.

A product of
TRIO-KENWOOD CORPORATION
6-17, 3-chome, Aobadai, Meguro-ku, Tokyo 153, Japan

KENWOOD ELECTRONICS, INC.
1315 E. Watsoncenter Rd, Carson, California 90745
75 Seaview Drive, Secaucus, New Jersey 07094, U.S.A.
TRIO-KENWOOD ELECTRONICS, N.V.
Leuvensesteenweg 184 B-1930 Zaventem, Belgium
TRIO-KENWOOD ELECTRONICS GmbH
Rudolf-Braas-Str. 20, 6056 Heusenstamm, West Germany
TRIO-KENWOOD FRANCE S.A.
5, Boulevard Ney, 75018 Paris, France
TRIO-KENWOOD (AUSTRALIA) PTY. LTD.
30 Whiting St., Artarmon, N.S.W. 2064, Australia
KENWOOD & LEE ELECTRONICS, LTD.
Room 501, Wang Kee Building, 5th Floor, 34-37, Connaught Road, Central, Hong Kong

C DIAGRAM

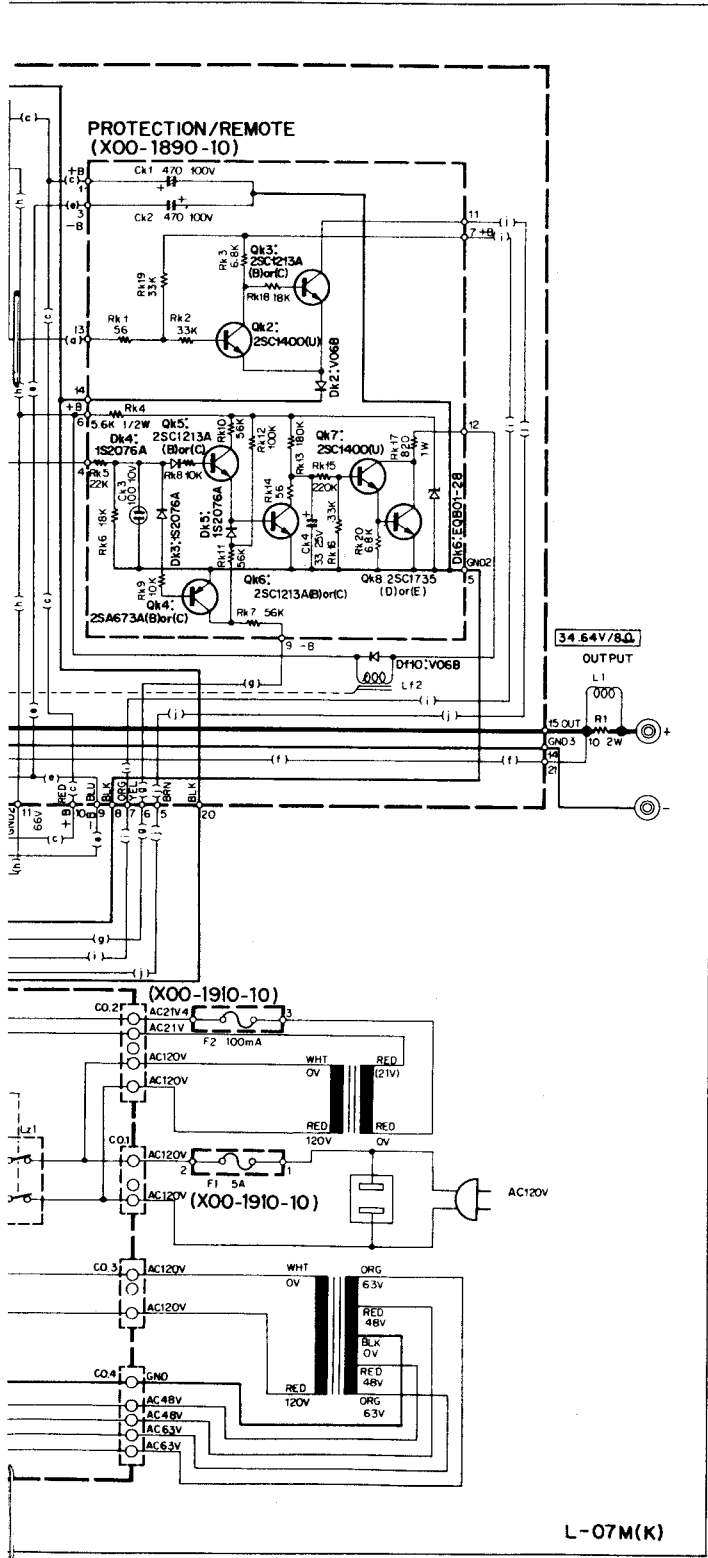

REVISED CIRCUITS

(M) TYPE

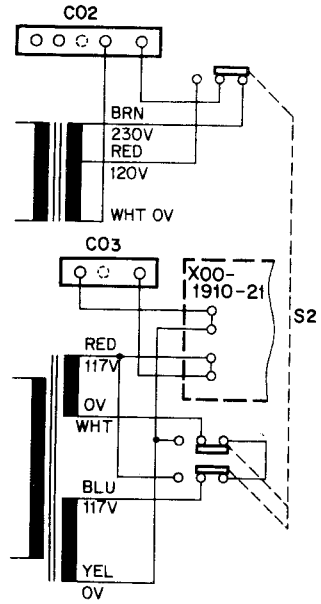

(W) TYPE

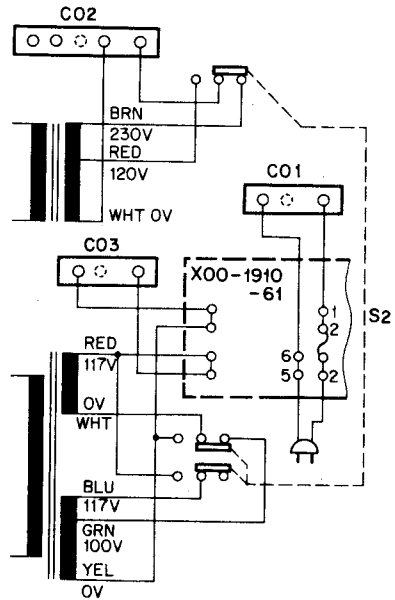

L-07M SCHEMATIC DIAGRAM

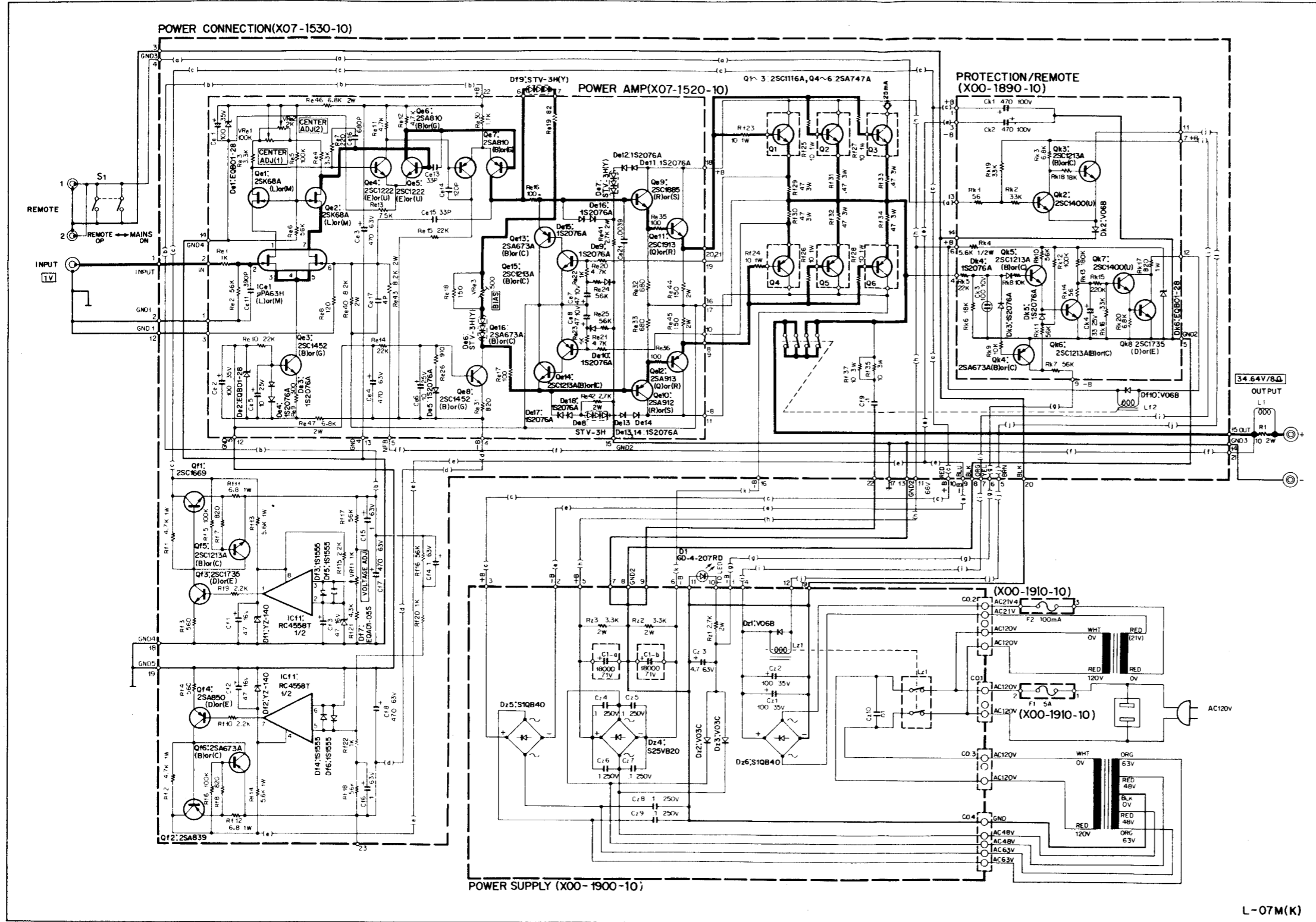

L-07M(K)

REVISED CIRCUITS

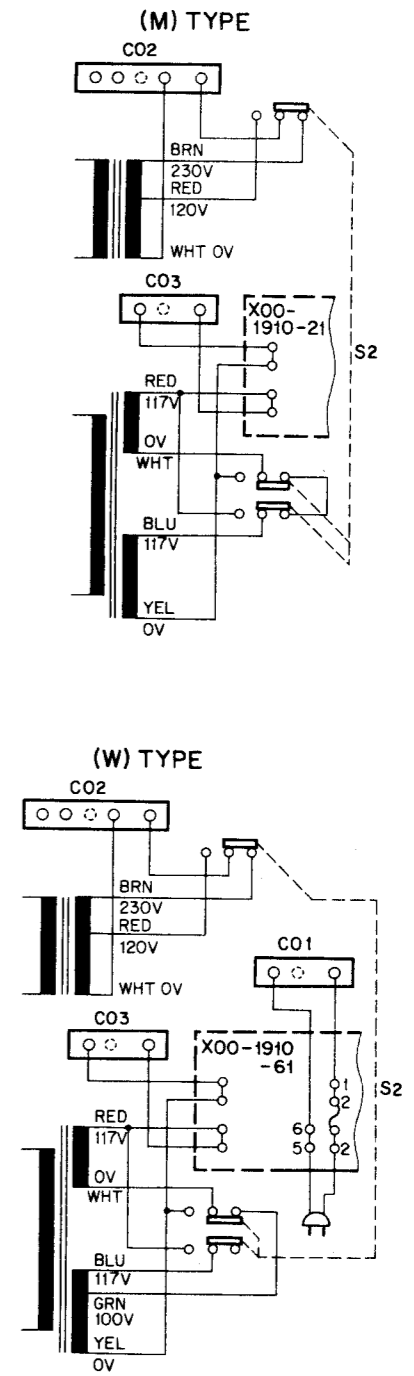

NOTE: We reserve the right to make modifications in this model in accordance with technical developments.

©1977-6 PRINTED IN JAPAN (T) 1,500