

RXD-M35 LS-M35/F30 SERVICE MANUAL (HM-335/HM-F30)

© 2002-12 PRINTED IN KOREA
B51-5813-00 (K/K) 3070

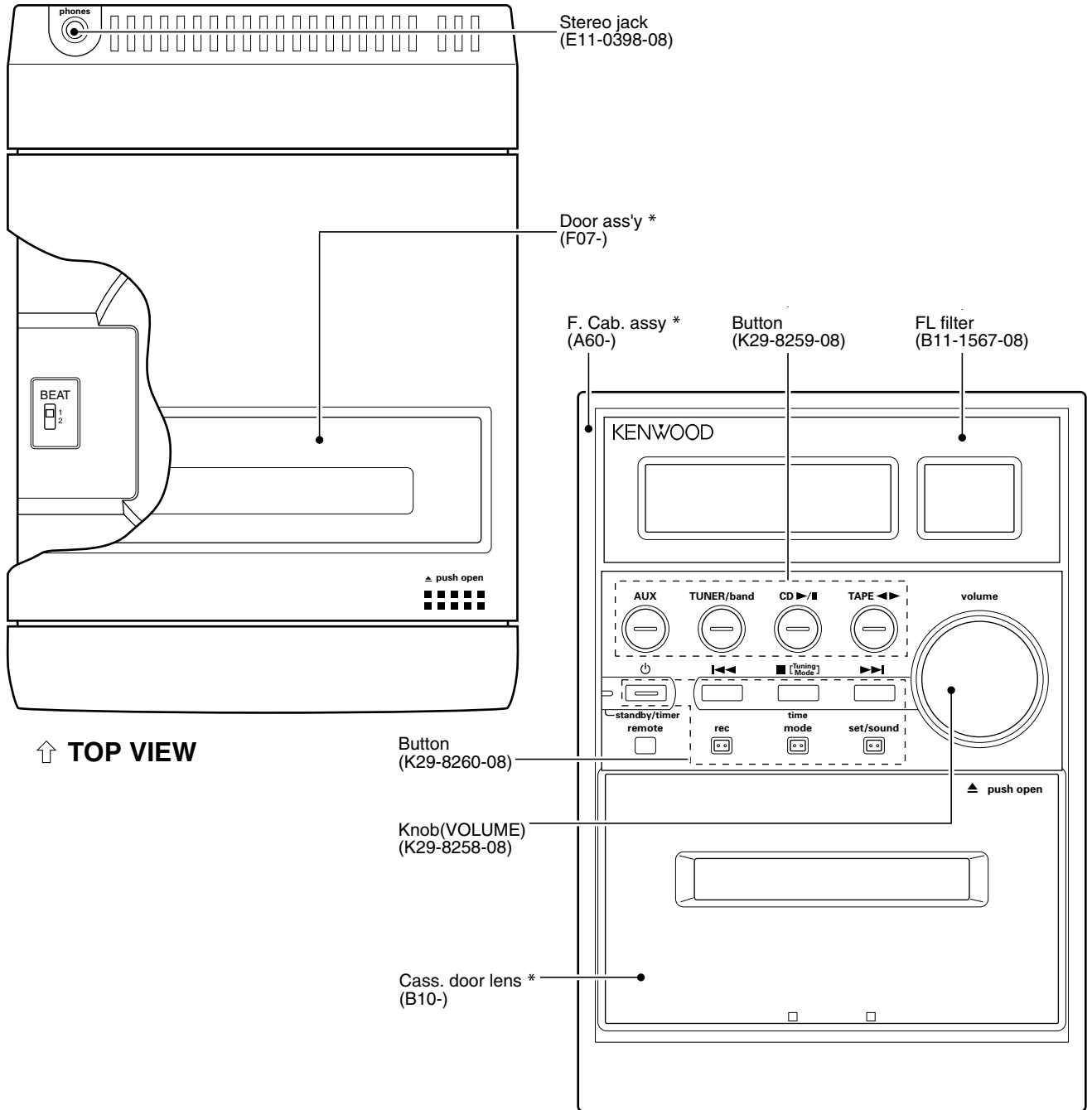

*** Refer to parts list on page 26 .**

In compliance with Federal Regulations, following are reproduction of labels on, or inside the product relating to laser product safety.

Caution : No connection of ground line if disassemble the unit. Please connect the ground line on rear panel, PCBs, Chassis and some others.

KENWOOD Corp. certifies this equipment conforms to DHHS Regulations No.21 CFR 1040. 10, Chapter 1, subchapter J.

DANGER : Laser radiation when open and interlock defeated. AVOID DIRECT EXPOSURE TO BEAM.



RXD-M35

CONTENTS / ACCESSORIES / CAUTIONS

Contents

CONTENTS / ACCESSORIES / CAUTIONS.....	2	SCHEMATIC DIAGRAM	19
EXTERNAL VIEW	3	EXPLODED VIEW	25
CIRCUIT DESCRIPTION	4	PARTS LIST.....	26
ADJUSTMENT	14	SPECIFICATIONS	Back cover
PC BOARD	15		

Accessories

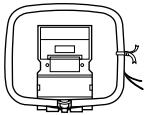
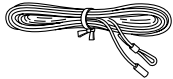
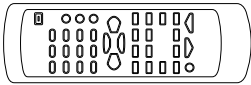
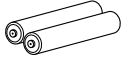
AM loop antenna (1) (T90-0846-08)	FM indoor antenna (1) (T90-0861-08)	Remote control unit (1) (A70-1568-05): E,T,H type (A70-1569-05): K,X type	Batteries(R6/AA) (2)
			



Cautions

Operation to reset

The microcomputer may fall into malfunction (impossibility to operate, erroneous display, etc.) when the power cord is unplugged while unit is ON or due to an external factor. In this case, execute the following procedure to reset the microcomputer and return it to normal condition.

- Please note that resetting the microcomputer clears the contents stored in and it returns to condition when it left the factory.

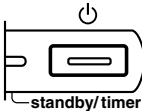
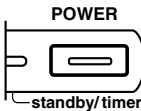
Unplug the power cord from the power outlet, then while holding the POWER or  key depressed, plug the power cord again.

 or  

After resetting the microcomputer, the display will show as follow:

R E S E T

Note related to transportation and movement

Before transporting or moving this unit, carry out the following operations.

- 1 Remove the CD from the unit.
- 2 Press the CD  key.
- 3 Wait for some time and verify that the display appears as above.
- 4 Wait a few seconds and turn the unit OFF.

N O D I S C

The marking of products using lasers (For countries other than U.S.A., U.S.-Military and Canada)

CLASS 1 LASER PRODUCT	CAUTION VISIBLE LASER RADIATION WHEN OPEN. DO NOT STARE INTO BEAM OR VIEW DIRECTLY WITH OPTICAL INSTRUMENTS.
--------------------------	--

The marking of this product has been classified as Class 1. It means that there is no danger of hazardous radiation outside the product.
Location: Back panel

Inside this laser product, a laser diode classified as Class 3A laser radiation is contained as alerted by the internal caution label shown above. Do not stare into beam or view directly with optical instruments.

EXTERNAL VIEW

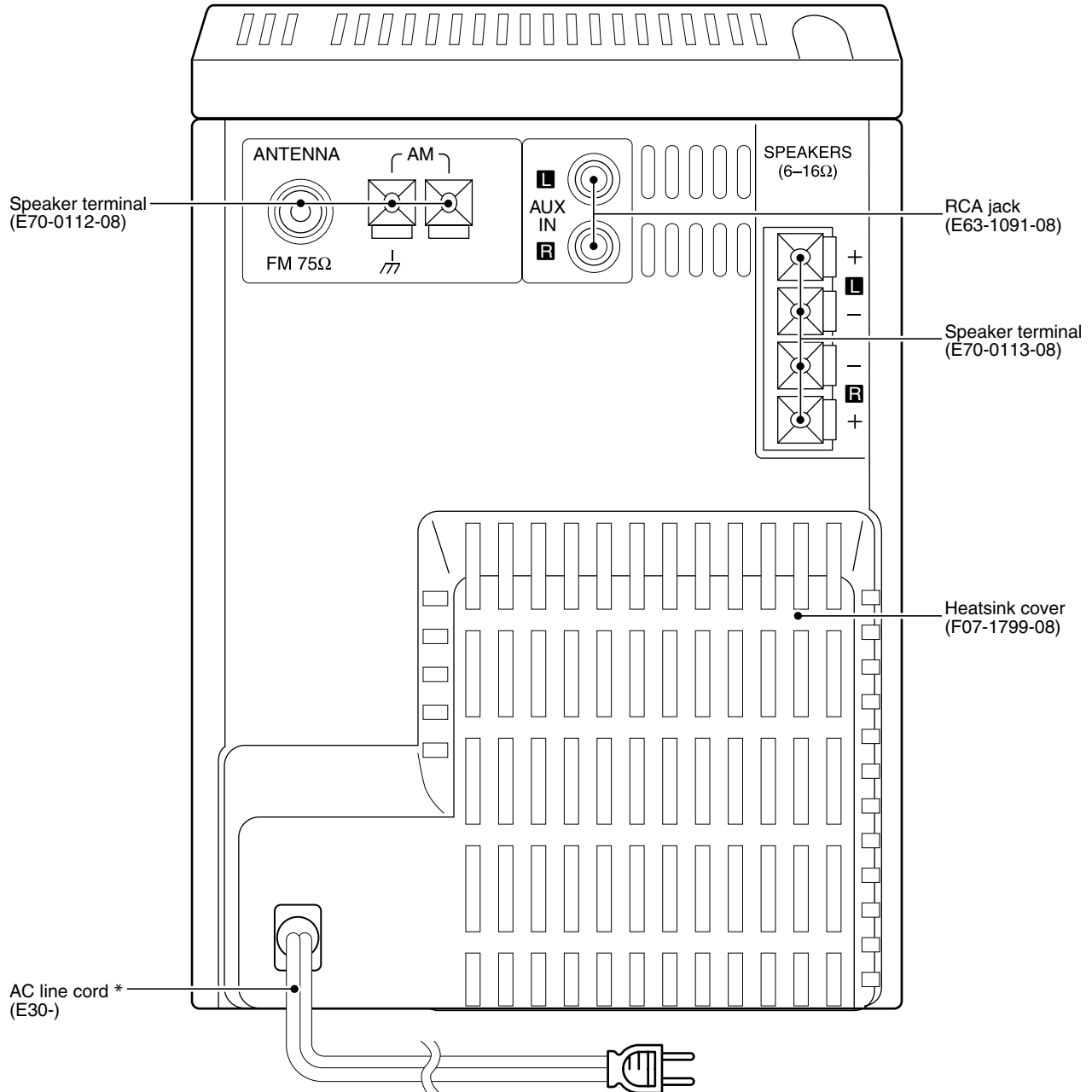

* Refer to parts list on page26.

SYSTEM CONFIGURATIONS

SYSTEM	RECEIVER	SPEAKERS	COLOR	FOR
HM-335-S	RXD-M35-S	LS-M35-S	SILVER	USA & AUSTRALIA
HM-335E-S	RXD-M35E-S	LS-M35-S	SILVER	
HM-F30-S	RXD-M35-S	LS-F30	SILVER	FRENCH
HM-335IT-S	RXD-M35-S	LS-F30	SILVER	ITALY
HM-335-N	RXD-M35-N	LS-M35-N	GOLD	
HM-335E-N	RXD-M35E-N	LS-M35-N	GOLD	

CIRCUIT DESCRIPTION

1. Initializing

1-1 Initialization Method

- While pressing the [POWER] key, turn the AC on.

1-2 Initialization Operation

- During the initial operation, the display shows "RESET" and after that it will be returned to standby condition.
- If any mechanisms error occurred, the error indication is displayed as "ERR" in the display.

1-3 Mechanism Initializations

① CD Mechanism

- If a mechanism error occurred, the error indication is displayed as "C ERR" in the display.

② Deck Mechanism

- If a mechanism error occurred, the error indication is displayed as "X ERR" in the display.

2. Tuner Types

Set	Destination	Band	Receiving Frequency Range	Channel Space	IF	RF
K,P	K1	FM	87.5MHz~108.0MHz	100kHz	+10.7MHz	25kHz
		AM	530kHz~1700kHz	10kHz	+450kHz	10kHz
E,T,H, E2	E3 RDS	FM	87.5MHz~108.0MHz	50kHz	+10.7MHz	25kHz
		AM	531kHz~1602kHz	9kHz	+450kHz	9kHz
M,X, V	E1	FM	87.5MHz~108.0MHz	50kHz	+10.7MHz	25kHz
		AM	531kHz~1602kHz	9kHz	+450kHz	9kHz
M,V	K2	FM	87.5MHz~108.0MHz	100kHz	+10.7MHz	25kHz
		AM	530kHz~1610kHz	10kHz	+450kHz	10kHz

Type	E,E2,T,H	K,P	M,V	X
Voltage (IC401, Pin3)	4.2V~5.0V	2.6V~4.1V	1.4V~2.5V	0.7V~1.3V

3. Tuner Preset Frequency

P.CH	Frequency			
	K1(K,P Type)	E3(E,T,H,E2 Type)	E1(M,X,V Type)	K2(M,V Type)
1	FM 98.30MHz	FM 98.30MHz	FM 98.30MHz	FM 98.30MHz
2	FM 108.0MHz	FM 108.0MHz	FM 108.0MHz	FM 108.0MHz
3	FM 89.10MHz	FM 89.10MHz	FM 89.10MHz	FM 89.10MHz
4	FM 87.50MHz	FM 87.50MHz	FM 87.50MHz	FM 87.50MHz
5	FM 90.00MHz	FM 90.00MHz	FM 90.00MHz	FM 90.00MHz
6	FM 87.50MHz	FM 87.50MHz	FM 87.50MHz	FM 87.50MHz
7	FM 87.50MHz	FM 87.50MHz	FM 87.50MHz	FM 87.50MHz
8	AM 1610kHz	AM 1503kHz	AM 1503kHz	FM 87.50MHz
9	AM 1700kHz	AM 1584kHz	AM 1584kHz	AM 1610kHz
10	AM 1000kHz	AM 999kHz	AM 999kHz	AM 1000kHz
11	AM 630kHz	AM 621kHz	AM 621kHz	AM 630kHz
12	AM 1440kHz	AM 1350kHz	AM 1350kHz	AM 1440kHz
13	FM 106.0MHz	FM 106.0MHz	FM 106.0MHz	FM 106.0MHz
14	AM 530kHz	AM 531kHz	AM 531kHz	AM 530kHz
15	FM 87.50MHz	FM 87.50MHz	FM 87.50MHz	FM 87.50MHz
16	FM 98.00MHz	FM 98.00MHz	FM 98.00MHz	FM 98.00MHz
17	FM 98.50MHz	FM 98.50MHz	FM 98.50MHz	FM 98.50MHz
18	FM 87.50MHz	FM 87.50MHz	FM 87.50MHz	FM 87.50MHz
19	AM 990kHz	AM 945kHz	AM 945kHz	AM 990kHz
20	FM 97.40MHz	FM 97.40MHz	FM 97.40MHz	FM 97.40MHz
21	AM 530kHz	AM 531kHz	AM 531kHz	AM 530kHz
22	FM 87.50MHz	FM 87.50MHz	FM 87.50MHz	FM 87.50MHz
23	FM 87.50MHz	FM 87.50MHz	FM 87.50MHz	FM 87.50MHz
24	FM 87.50MHz	FM 87.50MHz	FM 87.50MHz	FM 87.50MHz
25	FM 87.50MHz	FM 87.50MHz	FM 87.50MHz	FM 87.50MHz
26	FM 87.50MHz	FM 87.50MHz	FM 87.50MHz	FM 87.50MHz
27	FM 87.50MHz	FM 87.50MHz	FM 87.50MHz	FM 87.50MHz
28	FM 87.50MHz	FM 87.50MHz	FM 87.50MHz	FM 87.50MHz
29	FM 87.50MHz	FM 87.50MHz	FM 87.50MHz	FM 87.50MHz
30	FM 106.0MHz	FM 106.0MHz	FM 106.0MHz	FM 106.0MHz

CIRCUIT DESCRIPTION

4. Test Mode

4-1 Setting method of the Test Mode

Test Mode	Keys	Setting Method
CD MODE	CD PLAY key	Insert the AC cord to AC wall outlet while holding down the left key.
DECK MODE	TAPE PLAY	

4-2 Cancel of the test mode

- Initialized and cancel the test mode if pulling out the power cord.
- Cancel the test mode only if the power key is turned off.

4-3 Contents of the Test Mode

- The muting during mode selection is not controlled in the test mode.
- During the test mode, it can be operated in a special manner that is different from an ordinary operation by using the keys on the main body, specifically as shown in the following tables

4-4 CD Test Mode

Keys	Display	Operation
CD-PLAY/PAUSE (Cyclically changed the mode 05 and 03 by pressing the key.)	05 * * : * *	<ul style="list-style-type: none"> • Tracking-servo on. • Pickup moves inward.
	(** : **)Time Display	
	03 * * : * *	<ul style="list-style-type: none"> • Tracking-servo off. (for checking TE) • Pickup moves outward.
CD STOP (Cyclically changed in the stop mode only.)	(** : **)Time Display	Stop the CD operation.
	00 : 00	Adjustment value/mean value
	07 FG/FE	FG value /FE value
	08 FB/FO	FBAL value /FO value
	09 TG/TE	TG value /TE value
10 TB/TO	TBAL value /TO value	
SKIP UP	Ex.0.1~0.2	• Track number up
SKIP DOWN	Ex.0.2~0.1	• Track number down.

4-5 Deck Test Mode

Keys	Display	Operation
TAPE REC	AUX	<ul style="list-style-type: none"> • 4 Seconds Recording <p>If the REC/ARM key is pressed, the system record for 4 seconds. Then, it rewinds to the REC starting position and plays back automatically. If the REC/ARM key is pressed, during the 4 seconds REC operation, the system records further for 4 seconds, then returns to the starting position of the first 4 seconds REC operation and plays back.</p>

* Mechanism half switches indication

The mechanism half switches status are indicated "blank" or "E" in the display.

8th Dot(Display)	1st figure	2nd figure	3rd figure	4th figure
Mechanism Half Switch	FWD REC Inhibit Detection SW	RVS REC Inhibit Detection SW	Cassette Half Detection SW	Tape Play Detection SW
ON	Blank	Blank	Blank	Blank
OFF	E	E	E	E

RXD-M35

CIRCUIT DESCRIPTION

5. Microcomputer : MN101C51F (IC401)

5-1 Microcomputer Peripheral Block Diagram

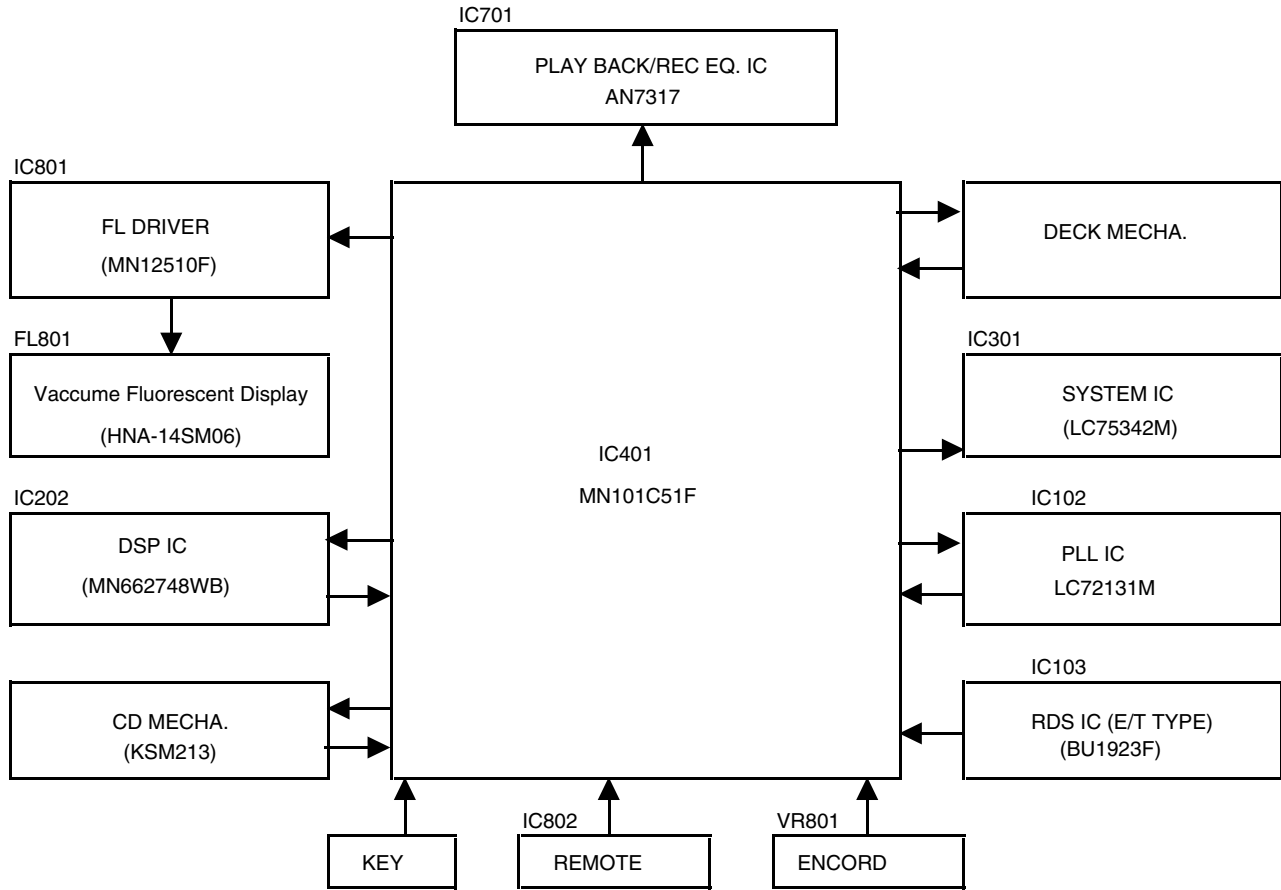

Key Matrix VREF =5.0V

Voltage Range	0	0.89	1.55	2.00	2.61	3.02	3.42	5.00
Key 1 (Pin 5)	ON/STANDBY	AUX	TUNER	SKIP DOWN	STOP	CD PLAY	SKIP UP	(off)
Key 2 (Pin 6)	REC				TAPE PLAY	MODE	SET	(off)

5-2 Pin Description of Microcomputer : MN101C51F (IC401)

Pin No.	Pin Name	I/O	Description
1	VREF -	-	Connected to power supply(+5.0V).
2	END SW	I	Reel sensor input for cassette deck.
3	TN TYPE	I	Discrimination of tuner destination.
4	S LEVEL	I	RDS signal level input(E/T type only).
5	KEY1	I	A/D key (key1) input port.
6	KEY2	I	A/D key (key2) input port.
7	A LEVEL	-	Unused.
8	TH	-	Unused.
9	CD PROTECTION	I	Detection port for CD protection.
10	VREF +	I	A/D reference voltage(+5V).
11	VCC	I	Power supply(+5.0V).
12	OSC2	O	Main clock oscillator(8.388MHz).
13	OSC1	I	Main clock oscillator(8.388MHz).
14	VSS	I	GND.
15	X1	I	Timer clock input(32.768kHz).

CIRCUIT DESCRIPTION

Pin No.	Pin Name	I/O	Description
16	X0	O	Timer clock output(32.768kHz).
17	MMOD	-	Connected to ground.
18	S DI	I	Data input from FL driver IC.
19	S.DO	O	Data output to FL driver IC.
20	S CK	O	Clock output to FL driver IC.
21	MLD	O	CD DSP command load signal output.
22	SUBQ	I	CD sub code input.
23	SQCK	O	Clock output for CD sub code.
24	CL SW	I	CD close detection switch input.
25	RESET	I	Reset signal input for microprocessor.
26	CE	I	Power failure input port.
27	OP SW	I	CD open detection switch input.
28	CD POWER	O	CD DSP power on/off control.
29	XRST	O	CD DSP reset output.
30	SLT SW	I	CD start limit switch input.
31	REM. CONTROL	I	Remote control signal input.
32	NO USE	-	Unused.
33	RDS CLK	I	RDS clock input. (E/T version only)
34	RESET2	-	Unused.
35	CD BLKCK	I	Sub code synchronous signal input.
36	MDATA	-	Unused.
37	STAT	I	CD DSP status signal input.
38	MCLK	O	CD DSP command clock signal output.
39	CLOSE	-	Unused.
40	OPEN	-	Unused.
41	PH IN	I	Unused.
42	FLASH UC1	-	Unused.
43	FLASH UC2	-	Unused.
44	V CE	O	Chip enable output to electronic volume system IC.
45	V CLK	O	Clock output to electronic volume system IC.
46	V DATA	O	Serial data output to electronic volume system IC.
47	PWR RELAY	O	Power relay control output. H = ON L = OFF
48,49	NO USE	-	Unused.
50	FLASH WRITE	-	Unused.
51	NO USE	-	Unused.
52	PLL CLK	O	PLL IC clock output.
53	PLL DO/ST	I	PLL IC data input.
54	PLL DATA	O	Data output to PLL IC.
55	PLL CE	O	PLL IC chip enable.
56	SD	I	SD detector input. H = NO TUNED L = TUNED
57	TU MUTE	O	Tuner mute control. L : MUTE ON
58	PACK SW	I	Deck pack switch input. H = OFF L = ON
59	F REC SW	I	Deck forward rec switch input. H = OFF L = ON
60	R REC SW	I	Deck reverse rec switch input. H = OFF L = ON
61	PLAY SW	I	Deck play switch input. H =OFF L =ON
62	B. CANCEL	-	Unused.
63	REC/PB	O	Deck rec/play control.
64	BIAS	O	Deck bias control.
65	A/B	O	Unused.
66	LINE MUTE	O	Deck line mute control.
67	REC MUTE	O	Rec mute control.
68	CPM	O	Deck capstan motor control.
69	SOL	O	Deck solenoid control.
70	RDS DATA	-	Unused.

CIRCUIT DESCRIPTION

Pin No.	Pin Name	I/O	Description
71	PROTECT	O	Detection input port for protection circuit H = PROTECTION ON
72	A_MUTE	O	Audio muting control output. H = OFF L = ON
73	SP. RERAY	O	Unused.
74	EEP SDA	I/O	EEPROM data input and output.
75	EEP SCL	O	EEPROM clock output.
76	ENC A	I	Rotary encoder input (up).
77	ENC B	I	Rotary encoder input (down).
78	LED. RED	O	Control port of standby/timer LED(red). L = ON
79	LED. GRN	O	Control port of standby/timer LED (yellow). L = ON
80	NCS	O	CS signal output to LCD driver IC.

6. Pin Description of IC's

6-1 CD RF AMP : AN8399SA-E1 (IC201)

Pin No.	Pin Name	I/O	Description
1	PD	I	APC Amp input.
2	LD	O	APC Amp output.
3	VCC	-	Power supply.
4	RF	I	RF amp inverting input.
5	RF OUT	O	RF addition amp output.
6	RF IN	I	AGC amp input.
7	LDRCTL	-	LD reference voltage control.
8	CAGC	-	AGC loop filter connection.
9	ARF	O	AGC output.
10	CEA	-	Capacitance connection for RF HPF-Amp.
11	RF ENV	O	3T-ENV output.
12	CSBDO	-	Capacitance connection for RF dark side envelope detection.
13	BDO	O	BDO output.
14	COFTR	-	Capacitance connection for RF bright side envelope detection.
15	OFTR	O	OFTR output.
16	NRFDET	O	NRFDET output.
17	GND	-	GND
18	SLPSW	-	Sleep mode control (connected to ground).
19	VREF	O	VREF output.
20	TEN	I	TE. Amp inverting input.
21	TEOUT	O	TE. Amp output.
22	FEN	I	FE. Amp inverting input.
23	FEOUT	O	FE. Amp output.
24	GCTL	O	Gain & APC control.
25	FBAL	O	F. BAL control.
26	TBAL	O	T. BAL control.
27	E	I	Tracking signal input 1.
28	F	I	Tracking signal input 2.
29	D	I	Focus signal input 4.
30	B	I	Focus signal input 2.
31	C	I	Focus signal input 3.
32	A	I	Focus signal input 1.

CIRCUIT DESCRIPTION

6-2 DSP IC : MN6627482WB(IC202)

Pin No.	Pin Name	I/O	Pin Description	Active	
				H	L
1	BCLK	O	Bit clock output for SRDATA.		
2	LRCK	O	L, R clock signal output.		
3	SRDATA	O	Serial data output.		
4	DVDD1	-	Digital power supply.		
5	DVSS1	-	Digital ground.		
6	TX	O	Digital audio interface signal output.		
7	MCLK	I	CPC command clock signal input.		
8	MDATA	I	CPU command data signal input.		
9	MLD	I	CPU command load signal input.		Load
10	SENSE	O	Sense signal output(OFT, FESL, NACEND, NAJEND, SFG).		
11	FLOCK	O	Focus servo signal output.		
12	TLOCK	O	Tracking servo signal output.		
13	BLKCK	O	Sub code block clock output. fBLKCK = 75Hz		
14	SQCK	I	Sub code Q data clock input pin.		
15	SUBQ	O	Sub code Q data signal output pin.		
16	DMUTE	I	Connected to be ground.	Mute	
17	STAT	O	Status signal output.		
18	XRST	I	Reset signal input.		Reset
19	SMCK	O	8.4672MHz clock signal output when MSEL is H. 4.2336MHz clock signal output when MSEL is L.		
20	PMCK	O	88.2kHz clock signal output when default. Play signal output when command is carry out.	Play	
21	TRV	O	Traverse forced feed output.		
22	TVD	O	Traverse drive output.		
23	PC	O	Spindle motor on signal output. L : ON (Default)		
24	ECM	O	Drive signal output for spindle motor (forced mode output).		
25	ECS	O	Drive signal output for spindle motor (servo error signal output).		
26	KICK	O	Kick pulse output for tracking driver.		
27	TRD	O	Tracking servo drive output.		
28	FOD	O	Focus drive output.		
29	VREF	I	Reference power supply for DA output section.		
30	FBAL	O	Focus balance adjusting output.		
31	TBAL	O	Tracking balance adjusting output.		
32	FE	I	Focus error signal input (analog input).		
33	TE	I	Tracking error signal input (analog input).		
34	RFENV	I	RF envelope signal input (analog input). Vibrating detection signal input when default.		
35	VDET	I/O	Software vibrating detection monitor output when command is executed.	Detected	
36	OFT	I	Off track signal input.	Off Track	
37	TRCRS	I	Track cross signal input pin (analog input).		
38	RFDET	I	RF detector signal input pin.		Detected
39	BDO	I	Drop out signal input.	Drop Out	
40	LDON	O	Laser on signal output.	ON	
41	PLL2	I/O	PLL loop filter switching pin.		
42	TOFS	O	Tracking offset adjusting output.		
43	WVEL	O	Double speed status signal output.	Double Speed	
44	ARF	I	RF signal input.		
45	IREF	I	Reference current input pin.		
46	DRF	I	DSL bias pin.		
47	DSL2	I/O	DSL loop filter pin.		
48	PLL2	I/O	PLL loop filter pin.		
49	VCO2	I/O	VCO loop filter pin.		

CIRCUIT DESCRIPTION

Pin No.	Pin Name	I/O	Pin Description	Active	
				H	L
50	AVDD2	-	Analog power supply for DSL, PLL, and DA output section.		
51	AVSS2	-	Analog ground for DSL, PLL, and DA output section.		
52	EFM/CK384	O	EFM signal output when IOSEL is H. 16.9344MHz clock output when IOSEL is L.		
53	PCK/DSL B	O	PLL clock output (fPCK = 4.3218MHz) or DSL balance output.		
54	VCOF2	I/O	Jitter free VCO loop filter pin.		
55	SUBC	O	Sub code serial output.		
56	SBCK	I	Clock input for sub code serial output.		
57	VSS	-	GND		
58	X1	I	Crystal oscillation circuit input. f = 16.9344MHz, 33.8688MHz		
59	X2	O	Crystal oscillation circuit output. f = 16.9344MHz, 33.8688MHz		
60	VDD	-	Power supply for crystal oscillation circuit.		
61	BYTCK	O	Bite clock signal output when IOSEL is H. Traverse stop signal output when IOSEL is L.	Stop Mode	
62	CLDCK	O	General IO pin when default. Sub code frame clock signal output (fCLDCK = 7.35kHz) when command is carry out.		
63	FCLK	O	General IO pin when default. Crystal frame clock signal output (fFCLK = 7.35kHz) when command is carry out.		
64	IPFLAG	O	Interpolation flag signal output.		
65	FLAG	O	Flag signal output.		
66	CLVS	O	Spindle servo phase synchronism signal output.	CLV	
67	CRC	O	Sub code CRC checked output.	OK	NG
68	DEMPH	O	De-emphasis detection signal output.	ON	
69	RESY	O	Re-frame synchronism signal RESY output of frame synchronism when IOSEL is H. H : Synchronized L : Non synchronized		
70	IOSEL	I	Switching pin for mode.		
71	TEST	I	Test pin.	Normal	
72	AVDD1	-	Analog power supply for audio output section.		
73	OUTL	O	L ch audio output.		
74	AVSS1	-	Analog ground for audio output section.		
75	OUTR	O	R ch audio output.		
76	RSEL	I	<ul style="list-style-type: none"> RF signal polarity assignment pin when default. RSEL is H when bright level is H. RSEL is L when bright level is L. General IO pin when command is executed. RF signal polarity assignment is set by command. 		
77	CSEL	I	Designation of oscillation frequency. H : f = 33.8688MHz L : f = 16.9344MHz		
78	PSEL	I	Test pin (Normal : L) when IOSEL is H. SRDATA input when IOSEL is L.		
79	MSEL	I	SMCK output when IOSEL is H. Switching pin of frequency. H : SMCK = 8.4672MHz L : SMCK = 4.2336MHz LRCK input when IOSEL is L. H : Lch data, L : Rch data SMCK = 4.2336MHz (Fixed)		
80	SSEL	I	SUBQ output mode switching pin when IOSEL is H. H : Q code buffer use mode L : CLDCK synchronism mode BCLK input when IOSEL is L. Q code buffer use mode		

CIRCUIT DESCRIPTION

6-3 4 channel BTL driver : AN4801SB-E1(IC203)

Pin No.	Pin Name	I/O	Description
1	IN2	I	Driver 2 input.
2	PC2	I	Power cut input (channel 2 mute).
3	IN1	I	Driver 1 input.
4	PC1	I	Power cut input (connected to ground).
5	RETO	O	Reset output.
6	N.C.1	-	Unused.
7	N.C.2	-	Unused.
8	PGND1	-	Ground 1 for driver.
9	PVCC1	-	Power supply 1 for driver.
10	V01-	O	Driver 1 inverted output.
11	V01+	O	Driver 1 forward output.
12	V02-	O	Driver 2 inverted output.
13	V02+	O	Driver 2 forward output.
14	V03-	O	Driver 3 inverted output.
15	V03+	O	Driver 3 forward output.
16	V04-	O	Driver 4 inverted output.
17	V04+	O	Driver 4 forward output.
18	PVCC2	-	Power supply 2 for driver.
19	PGND2	-	Ground 2 for driver.
20	STBY	I	Standby input.
21	N.C.3	-	Unused.
22	N.C.4	-	Unused.
23	SVCC	-	Power supply.
24	VREF	-	Reference voltage input.
25	IN4	I	Driver 4 input.
26	IN3	I	Driver 3 input

6-4 PLL Frequency Synthesizer LSI : LC72131M (IC102)

Pin No.	Pin Name	I/O	Pin Description
1	X IN	I	Crystal resonator connection.
2	CE	I	Chip enable.
3	DI	I	Input serial data.
4	CL	I	Used as the synchronization clock when serial data is input to the DI(pin 3), or when serial data is output DO(pin 5).
5	DO	O	Outputs serial data.
6	AM (B01)	O	<ul style="list-style-type: none"> • Dedicated output pins. • The output states are determined by B01 to B04 in the serial data. "Data"=0 : Open "Data"=1 : Low • These pins go to the open state after the power-on reset.
7	EMPH (B02)		
8	S/M (B03)		
9	FM (B04)		
10	ATT (I01)	I/O	Pins used for both input and output. The input or output state is determined by bits I0C1 and I0C2 in the serial data. Data = 0 : Open, Data = 1: Low
12	IF CON (I02)		
11	IF IN	I	IF count input.
13	AM IN	I	Local oscillator signal input.
14	FM IN	I	Local oscillator signal input.
15	VDD	-	Power supply.
16	PD	O	PLL charge pump output.
17	AIN	I	The MOS transistor used for the PLL active low-pass filter.
18	AOUT	O	
19	VSS	-	Ground.
20	X OUT	O	Crystal resonator connection.

CIRCUIT DESCRIPTION

6-5 RDS Demodulator IC : BU1923F (IC103)

Pin No.	Pin Name	I/O	Description
1	QUAL	O	Output for signal quality indication.
2	RDS DATA	O	Demodulation data output.
3	VREF	I	Reference voltage input.
4	MUX	I	Composite signal input.
5	VDD1	-	Analog power supply.
6	VSS1	-	Analog GND.
7	VSS3	-	Analog GND.
8	CMP	I	Comparator.
9	T1	I	Test pin.
10	T2	I	Test pin.
11	VSS2	-	Digital GND.
12	VDD2	-	Digital power supply.
13	XI	I	Crystal oscillation circuit input.
14	XO	O	Crystal oscillation circuit output.
15	N.C.	-	Unused.
16	RDS CLK	I/O	Demodulation clock.

6-6 Electronic Volume System IC : LC75342M (IC301)

Pin No.	Pin Name	I/O	Description
1	V.DATA	I	Serial data input pin for control.
2	V.CE	I	Chip enable pin.
3	VSS	-	Ground pin.
4	TEST	-	Electronic volume control pin. (To be connected to the VSS.)
5 26	LOUT ROUT	O	Volume + equalizer output pins.
6, 7 24,25	LBASS2, LBASS1 RBASS1, RBASS2	-	Bass-band filter comprising capacitor and resistor connection pins.
8 23	LTRE RTRE	-	Capacitor connection pins comprising treble band filter.
9 22	LE IN RE IN	I	Volume + equalizer input pins.
10 21	LS OUT RS OUT	O	Input selector output pins.
11,12 13,14 17,18 19,20	L CD, L TUNER L TAPE, L AUX R AUX, R TAPE R TUNER, R CD	I	Input signal pins.
15,16,27	N.C.	-	To be open or connected to VSS.
28	VREF	-	Reference voltage for analog ground.
29	VDD	-	Power supply pin.
30	V.CLK	I	Clock input pin for control.

CIRCUIT DESCRIPTION

6-7 FL Driver : MN12510F (IC801)

Pin No.	Pin Name	I/O	Pin Description
1~10 12~15	DGT(13~4) DGT(3~0)	O	Output pin of Grid.
11,17	N.C.(1,2)	-	Unused.
16	VPP	-	Power supply (-) for FL driver.
18	VDD	-	Power supply for (+5.0V) FL driver.
19	OSC1	I	Crystal oscillation circuit input.
20	OSC2	O	Crystal oscillation circuit output.
21	VSS	-	GND
22	CE	I	Serial data transfer pin. Chip select input.
23	S.CK	I	Synchronism clock input.
24	S.DI	I	Transfer data input.
25	S.DO	O	Input pin of system reset.
26~30	P30~P34	O	Control port of current buffer.
31~44	SEG(0~13)	O	Output pin of segment.

6-8 Power Amplifier (L Channel) : TDA2030A (IC602)

Pin No.	Pin Name	I/O	Description
1	LIN	I	Left channel input.
2	LNF	I	Left channel feed back.
3	-VS	-	Power supply (-B)
4	LOUT	O	Left channel output.
5	+VS	-	Power supply (+B)

RXD-M35

ADJUSTMENT

1. AM SECTION

fL : Low-range frequency

K Type : 530kHz Other Types : 531kHz

fH : High-range frequency

K Type : 1610kHz Other Types : 1602kHz

Signal generator : 400HZ, 30%, AM modulated Antenna Input Level : 60dBf

Test Stage	Input Frequency	Output Settings	Frequency Display	Adjusting Parts	Setting
AM Band Coverage	fL	-	fL	T102	2.5V±0.1V
* AM Tracking	fL fH	Speaker Terminal	fL fH	T101 TC101	Maximum Output
AM IF	fL	Speaker Terminal	fL	T103	Minimum Distortion

* Antenna Input Level : 30~40dBf

2. FM SECTION

Signal generator : 1kHz, 75kHz dev, FM modulated Antenna Input Level : 60dBf

Test Stage	Input Frequency	Output Settings	Frequency Display	Adjusting Parts	Setting
FM IFT	98.00MHz (Stereo)	Speaker Terminal	98.00MHz (Stereo)	FM FRONT END	Minimum Distortion
FM DET	98.00MHz (Mono)	Speaker Terminal	98.00MHz (Mono)	T104	Minimum Distortion
TUNED LEVEL	98.00MHz (35dBf ±10dBf)	-	98.00MHz	VR101	*

* Adjust VR101 and stop at the point where tuned (LCD) goes on.

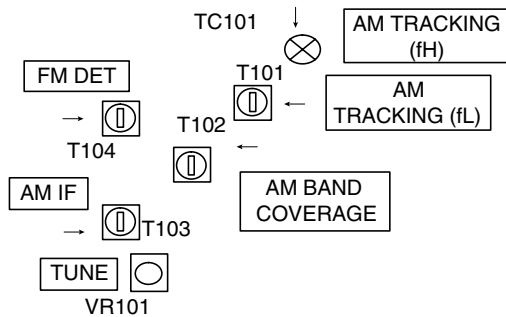

Adjusting Parts Lay Out

PC BOARD (Component side view)

1
2
3
4
5
6
7

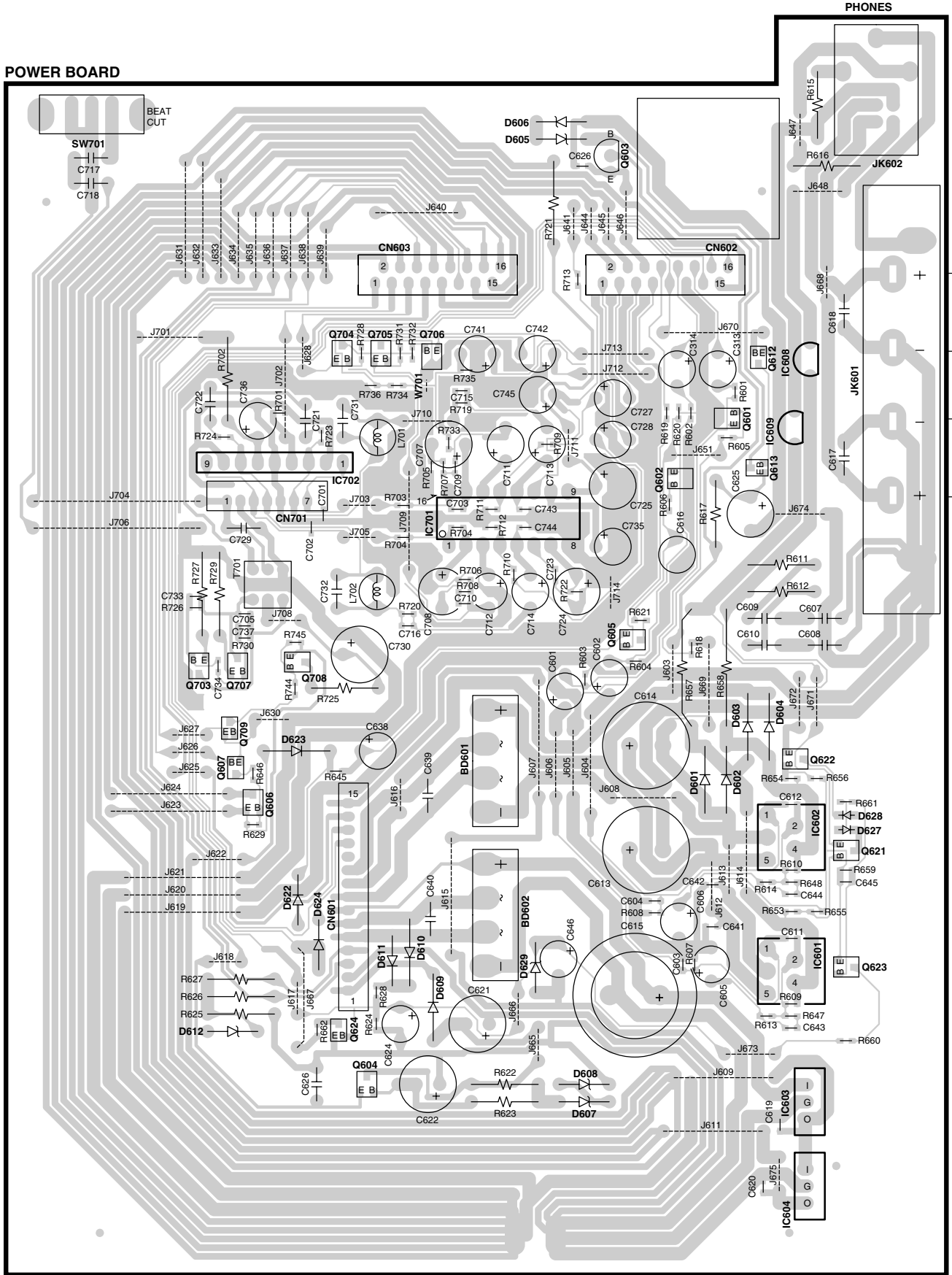

Refer to the schematic diagram for the value of resistors and capacitors.

PC BOARD (Component side view)

TRANSFORMER BOARD

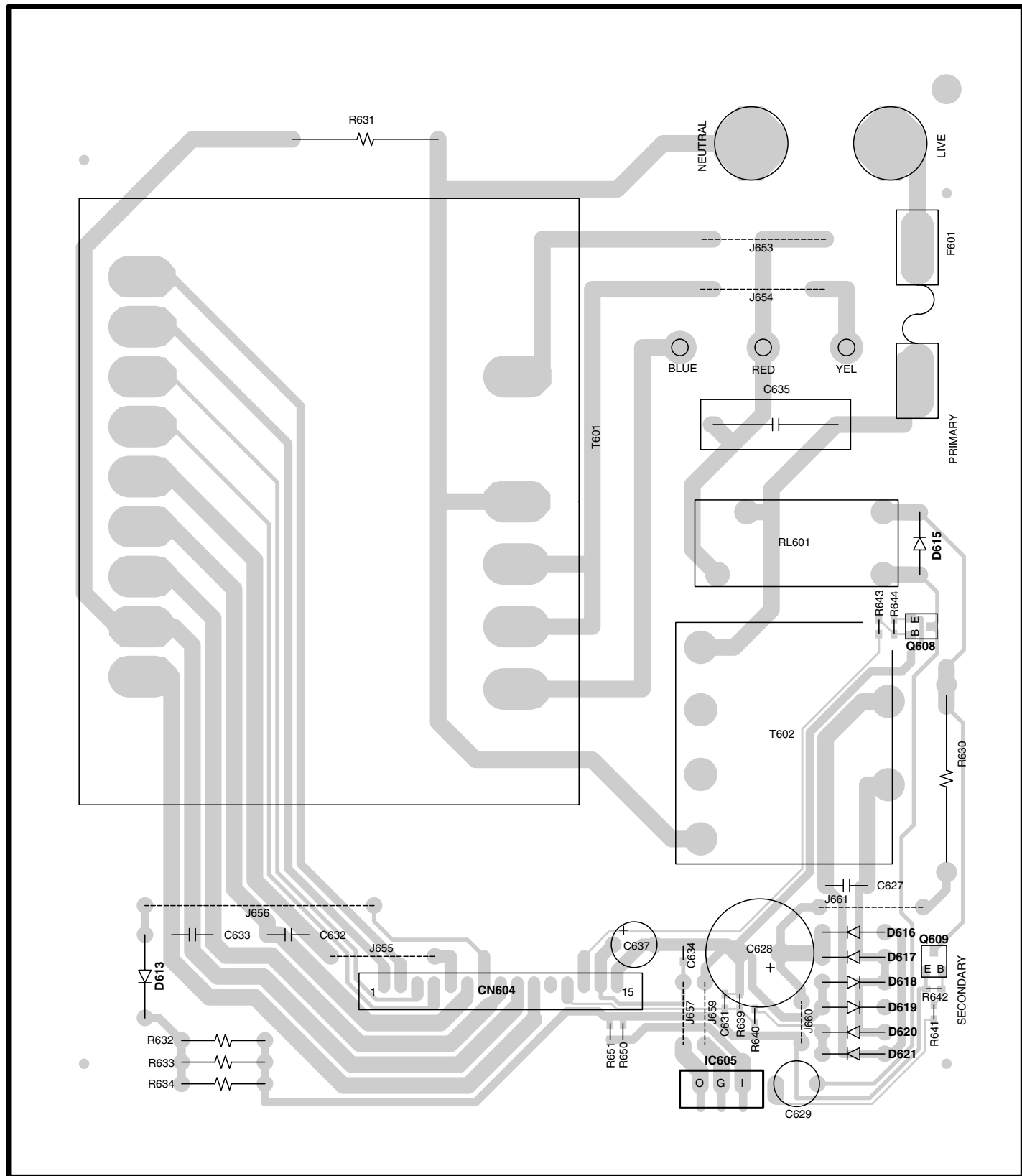

PC BOARD(Component side view)

MAIN BOARD

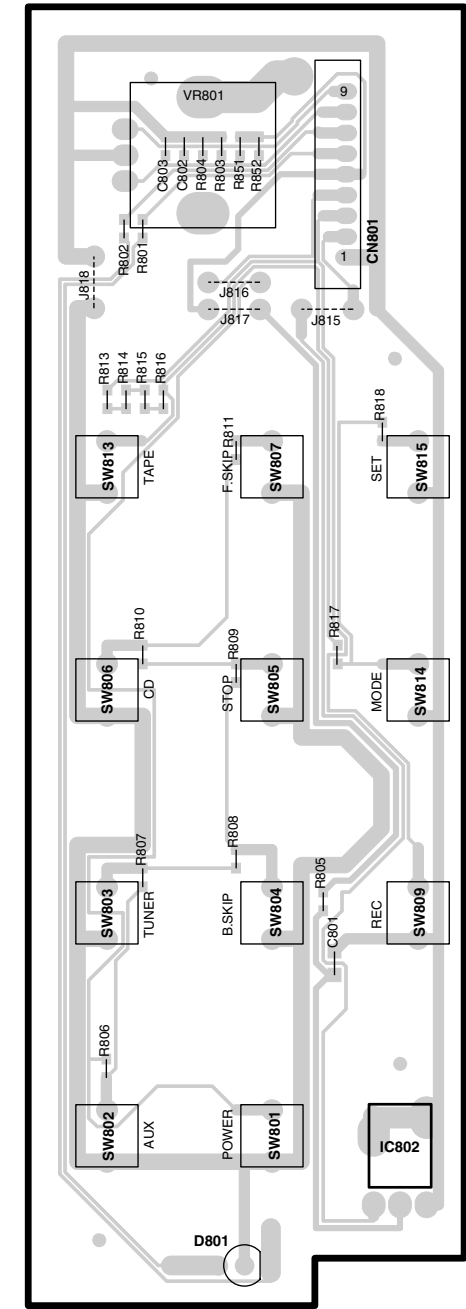
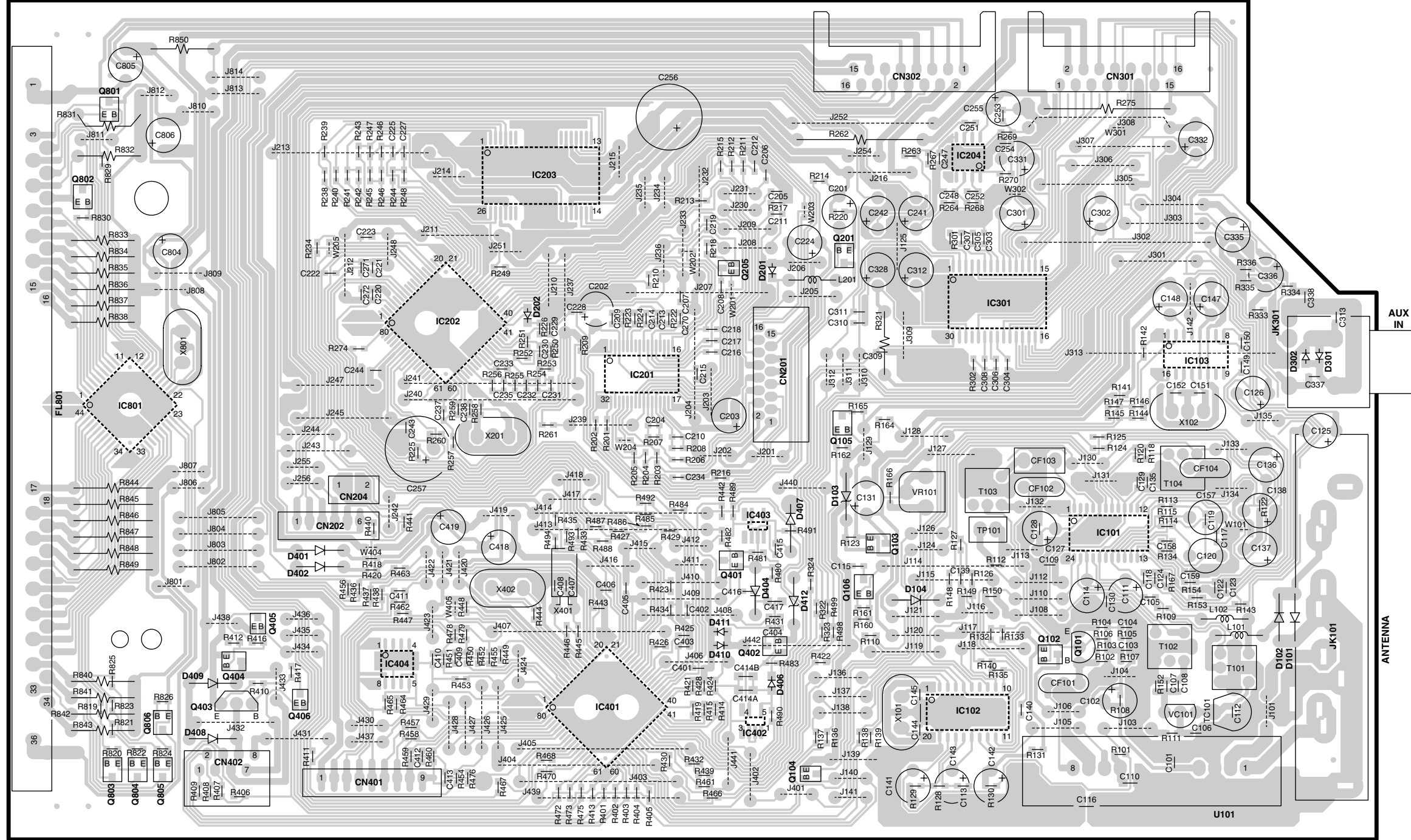

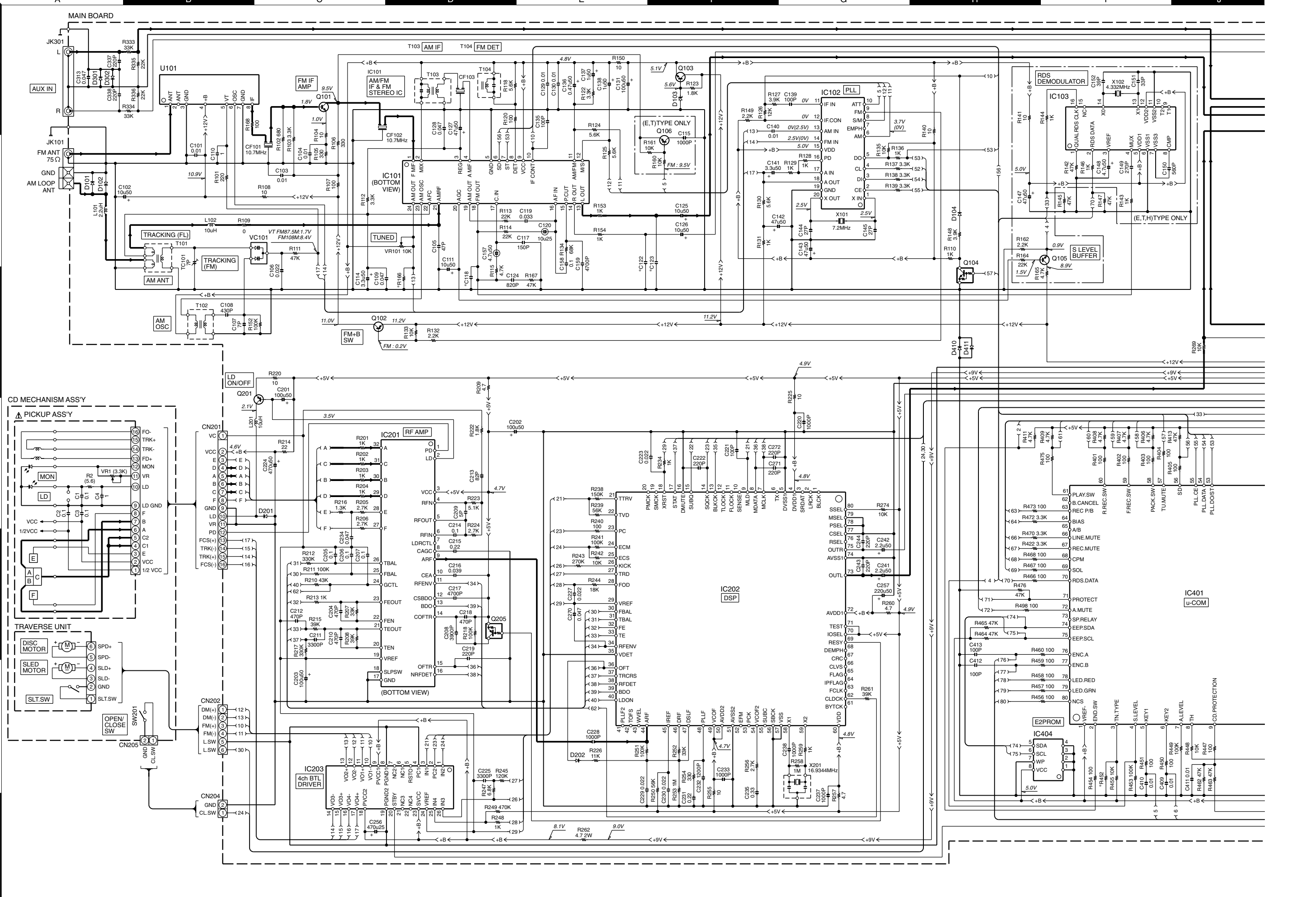

A

B

C

D

E

F

G

H

I

J

2

3

4

5

6

7

MAIN BOARD

CD MECHANISM ASSY

TRVERSE UNIT

4ch BTL DRIVER

E2PROM

JK301

JK101

LD ON/OFF

PICKUP ASSY

DISC MOTOR

SLED MOTOR

OPEN/CLOSE SW

CD PROTECTION

U101

IC101

VC101

IC201

IC203

IC404

IC401

T103

Q101

VR101

Q201

Q205

Q203

Q204

T104

Q103

Q102

Q202

Q204

Q201

Q205

IC102

IC103

IC106

IC202

IC204

IC402

IC403

R101

R102

R103

R104

R105

R106

R107

R108

R109

R110

R111

R112

R113

R114

R115

R116

R117

R118

R119

R120

R121

R122

R123

R124

R125

R126

R127

R128

R129

R130

R131

R132

R133

R134

R135

R136

R137

R138

R139

R140

R141

R142

R143

R144

R145

R146

R147

R148

R149

R150

R151

R152

R153

R154

R155

R156

R157

R158

R159

R160

R161

R162

R163

R164

R165

R166

R167

R168

R169

R170

R171

R172

R173

R174

R175

R176

R177

R178

R179

R180

R181

R182

R183

R184

R185

R186

R187

R188

R189

R190

R191

AM ANT

FM ANT

AM OSC

LD

MON

DISC MOTOR

SLED MOTOR

OPEN/CLOSE SW

CD PROTECTION

AM IF AMP

AM/FM IF & FM STEREO IC

TRACKING (FL)

VC101

LD ON/OFF

MON

DISC MOTOR

SLED MOTOR

OPEN/CLOSE SW

FM IF AMP

AM/FM IF & FM STEREO IC

TRACKING (FM)

VC101

LD ON/OFF

MON

DISC MOTOR

SLED MOTOR

OPEN/CLOSE SW

FM IF AMP

AM/FM IF & FM STEREO IC

TRACKING (FM)

VC101

LD ON/OFF

MON

DISC MOTOR

SLED MOTOR

OPEN/CLOSE SW

FM IF AMP

AM/FM IF & FM STEREO IC

TRACKING (FM)

VC101

LD ON/OFF

MON

DISC MOTOR

SLED MOTOR

OPEN/CLOSE SW

FM IF AMP

AM/FM IF & FM STEREO IC

TRACKING (FM)

VC101

LD ON/OFF

MON

DISC MOTOR

SLED MOTOR

OPEN/CLOSE SW

FM IF AMP

AM/FM IF & FM STEREO IC

TRACKING (FM)

VC101

LD ON/OFF

MON

DISC MOTOR

SLED MOTOR

OPEN/CLOSE SW

FM IF AMP

AM/FM IF & FM STEREO IC

TRACKING (FM)

VC101

LD ON/OFF

MON

DISC MOTOR

SLED MOTOR

OPEN/CLOSE SW

FM IF AMP

AM/FM IF & FM STEREO IC

TRACKING (FM)

VC101

LD ON/OFF

MON

DISC MOTOR

SLED MOTOR

OPEN/CLOSE SW

FM IF AMP

AM/FM IF & FM STEREO IC

TRACKING (FM)

VC101

LD ON/OFF

MON

DISC MOTOR

SLED MOTOR

OPEN/CLOSE SW

FM IF AMP

AM/FM IF & FM STEREO IC

TRACKING (FM)

VC101

LD ON/OFF

MON

DISC MOTOR

SLED MOTOR

OPEN/CLOSE SW

FM IF AMP

AM/FM IF & FM STEREO IC

TRACKING (FM)

VC101

LD ON/OFF

MON

DISC MOTOR

SLED MOTOR

OPEN/CLOSE SW

FM IF AMP

AM/FM IF & FM STEREO IC

TRACKING (FM)

VC101

LD ON/OFF

MON

DISC MOTOR

SLED MOTOR

OPEN/CLOSE SW

FM IF AMP

AM/FM IF & FM STEREO IC

TRACKING (FM)

VC101

LD ON/OFF

MON

DISC MOTOR

SLED MOTOR

OPEN/CLOSE SW

FM IF AMP

AM/FM IF & FM STEREO IC

TRACKING (FM)

VC101

LD ON/OFF

MON

DISC MOTOR

SLED MOTOR

OPEN/CLOSE SW

FM IF AMP

AM/FM IF & FM STEREO IC

TRACKING (FM)

VC101

LD ON/OFF

MON

DISC MOTOR

SLED MOTOR

OPEN/CLOSE SW

FM IF AMP

AM/FM IF & FM STEREO IC

TRACKING (FM)

VC101

LD ON/OFF

MON

DISC MOTOR

SLED MOTOR

OPEN/CLOSE SW

FM IF AMP

AM/FM IF & FM STEREO IC

TRACKING (FM)

VC101

LD ON/OFF

MON

DISC MOTOR

SLED MOTOR

OPEN/CLOSE SW

MAIN BOARD

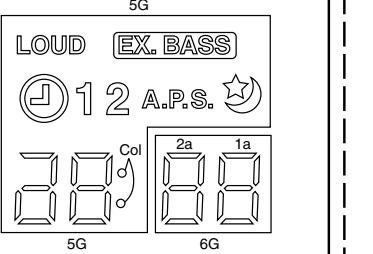
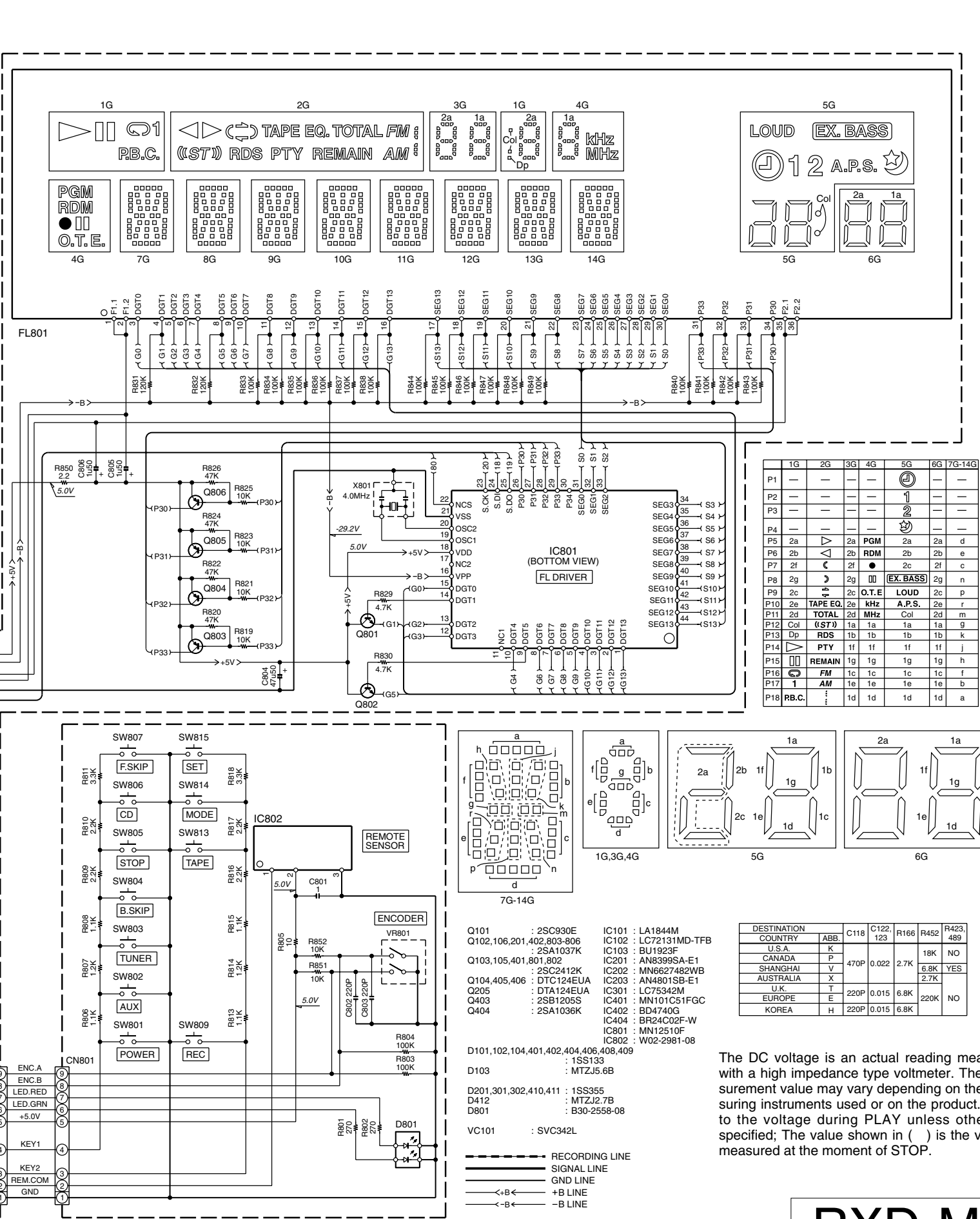
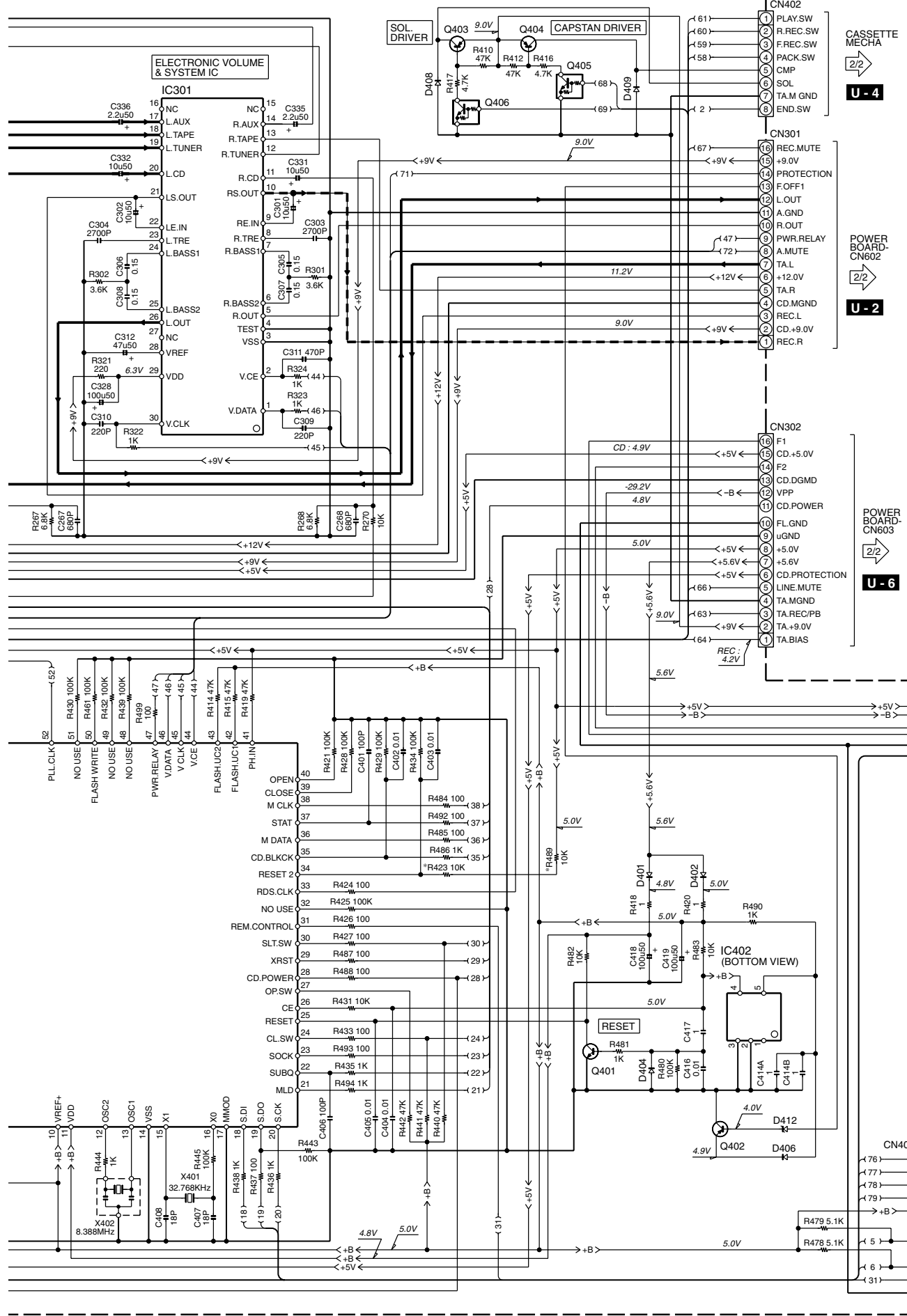

	1G	2G	3G	4G	5G	6G	7G-14G
P1	—	—	—	①	—	—	—
P2	—	—	—	②	—	—	—
P3	—	—	—	③	—	—	—
P4	—	—	—	④	—	—	—
P5	2a	△	2a	PGM	2a	2a	d
P6	2b	▽	2b	RDM	2b	2b	e
P7	2f	◁	2f	●	2c	2f	c
P8	2g	▷	2g	□	EX. BASS	2g	n
P9	2c	—	—	○	O.T.E.	2c	p
P10	2e	TAPE EQ.	2e	MHZ	A.P.S.	2e	r
P11	2d	TOTAL	2d	Col	2d	2d	m
P12	Col	(ST)	1a	1a	1a	1a	g
P13	Col	RDS	1b	1b	1b	1b	k
P14	△	PTY	1f	1f	1f	1f	j
P15	▽	REMAIN	1g	1g	1g	1g	h
P16	◁	FM	1c	1c	1c	1c	f
P17	▷	AM	1e	1e	1e	1e	b
P18	RB.C.	—	1d	1d	1d	1d	a

DESTINATION	COUNTRY	ABB.	C118	C122	R166	R452	R423	R429
U.S.A.	U.S.A.	K	—	—	—	—	—	—
CANADA	CANADA	P	—	—	—	—	18K	NO
SHANGHAI	SHANGHAI	V	470P	0.022	2.7K	—	6.8K	YES
AUSTRALIA	AUSTRALIA	X	—	—	—	—	2.7K	—
U.K.	U.K.	T	—	—	—	—	—	—
EUROPE	EUROPE	E	220P	0.015	6.8K	—	220K	NO
KOREA	KOREA	H	220P	0.015	6.8K	—	—	—

The DC voltage is an actual reading measured with a high impedance type voltmeter. The measurement value may vary depending on the measuring instruments used or on the product. Refer to the voltage during PLAY unless otherwise specified; The value shown in () is the voltage measured at the moment of STOP.

CAUTION: For continued safety, replace safety critical components only with manufacturer's recommended parts (refer to parts list). Δ indicates safety critical components. For continued protection against risk of fire, replace only with same type and rating fuse(s). To reduce the risk of electric shock, leakage-current or resistance measurements shall be carried out (exposed parts are acceptably insulated from the supply circuit) before the appliance is returned to the customer.

Note: Unit has a protection circuiting it use TDA2030A.
TDA2040A is available for no protection circuiting.

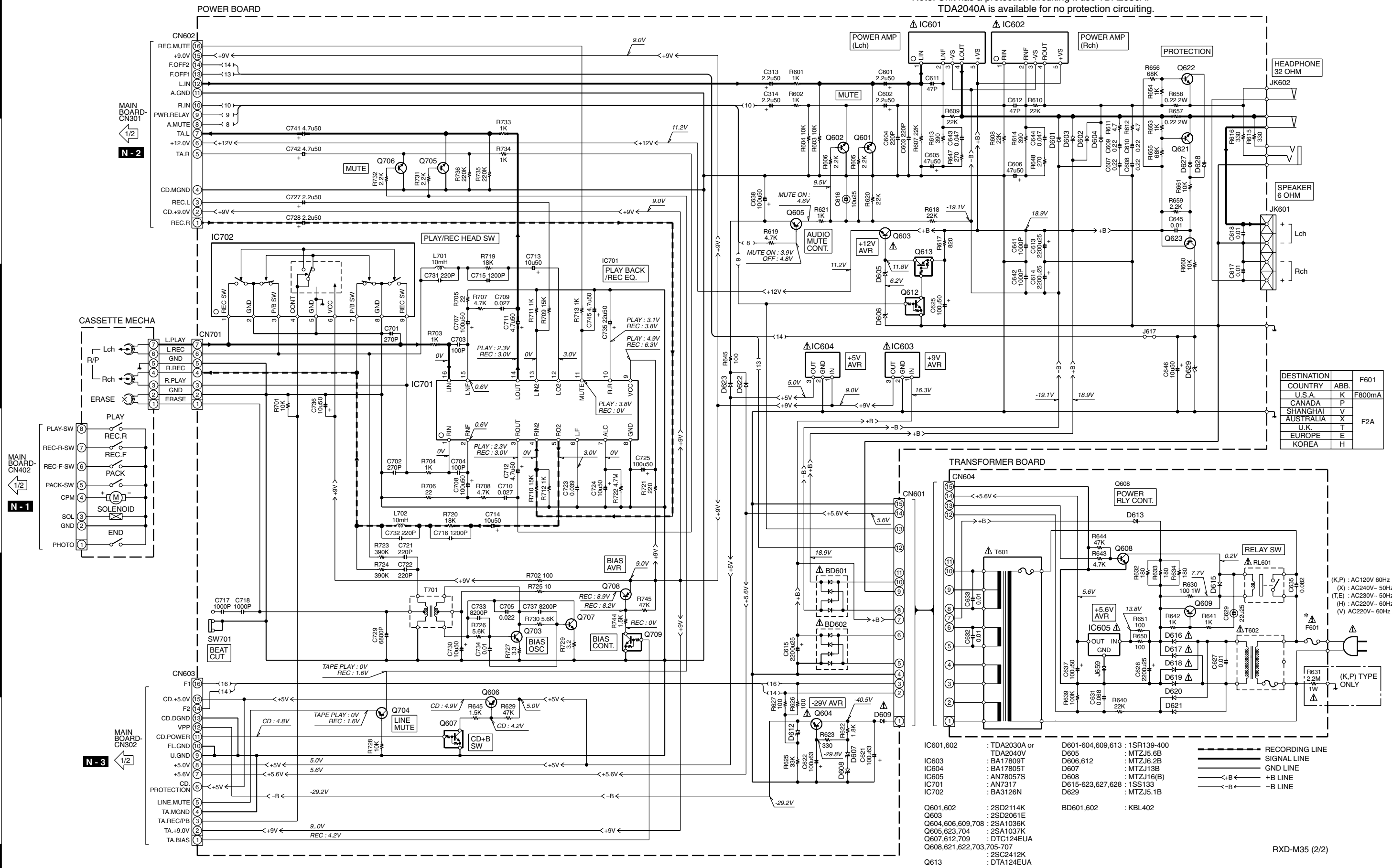

DESTINATION	COUNTRY	ABB.	F601
U.S.A.	U.S.A.	K	F800mA
CANADA	CANADA	P	
SHANGHAI	SHANGHAI	V	
AUSTRALIA	AUSTRALIA	X	
U.K.	U.K.	T	
EUROPE	EUROPE	E	
KOREA	KOREA	H	

(K,P) : AC120V 60Hz
(X) : AC240V - 50Hz
(T,E) : AC230V - 50Hz
(H) : AC220V - 60Hz
(V) : AC220V - 60Hz

--- RECORDING LINE
--- SIGNAL LINE
--- GND LINE
--- +B LINE
--- -B LINE

- IC601,602 : TDA2030A or TDA2040V
- IC603 : BA17809T
- IC604 : BA17805T
- IC605 : AN78057S
- IC701 : AN7317
- IC702 : BA3126N
- Q601,602 : 2SD2114K
- Q603 : 2SD2061E
- Q604,606,609,708 : 2SA1036K
- Q605,623,704 : 2SA1037K
- Q607,612,709 : DTC124EUA
- Q608,621,622,703,705-707 : 2SC2412K
- Q613 : DTA124EUA
- D601-604,609,613 : 1SR139-400
- D605 : MTZJ5.6B
- D606,612 : MTZJ6.2B
- D607 : MTZJ13B
- D608 : MTZJ16(B)
- D615-623,627,628 : 1SS133
- D629 : MTZJ5.1B
- BD601,602 : KBL402

RXD-M35 (2/2)

CAUTION: For continued safety, replace safety critical components only with manufacturer's recommended parts (refer to parts list). Δ indicates safety critical components. For continued protection against risk of fire, replace only with same type and rating fuse(s). To reduce the risk of electric shock, leakage-current or resistance measurements shall be carried out (exposed parts are acceptably insulated from the supply circuit) before the appliance is returned to the customer.

The DC voltage is an actual reading measured with a high impedance type voltmeter with no signal input. The measurement value may vary depending on the measuring instruments used or on the product.

Y39-4342-70



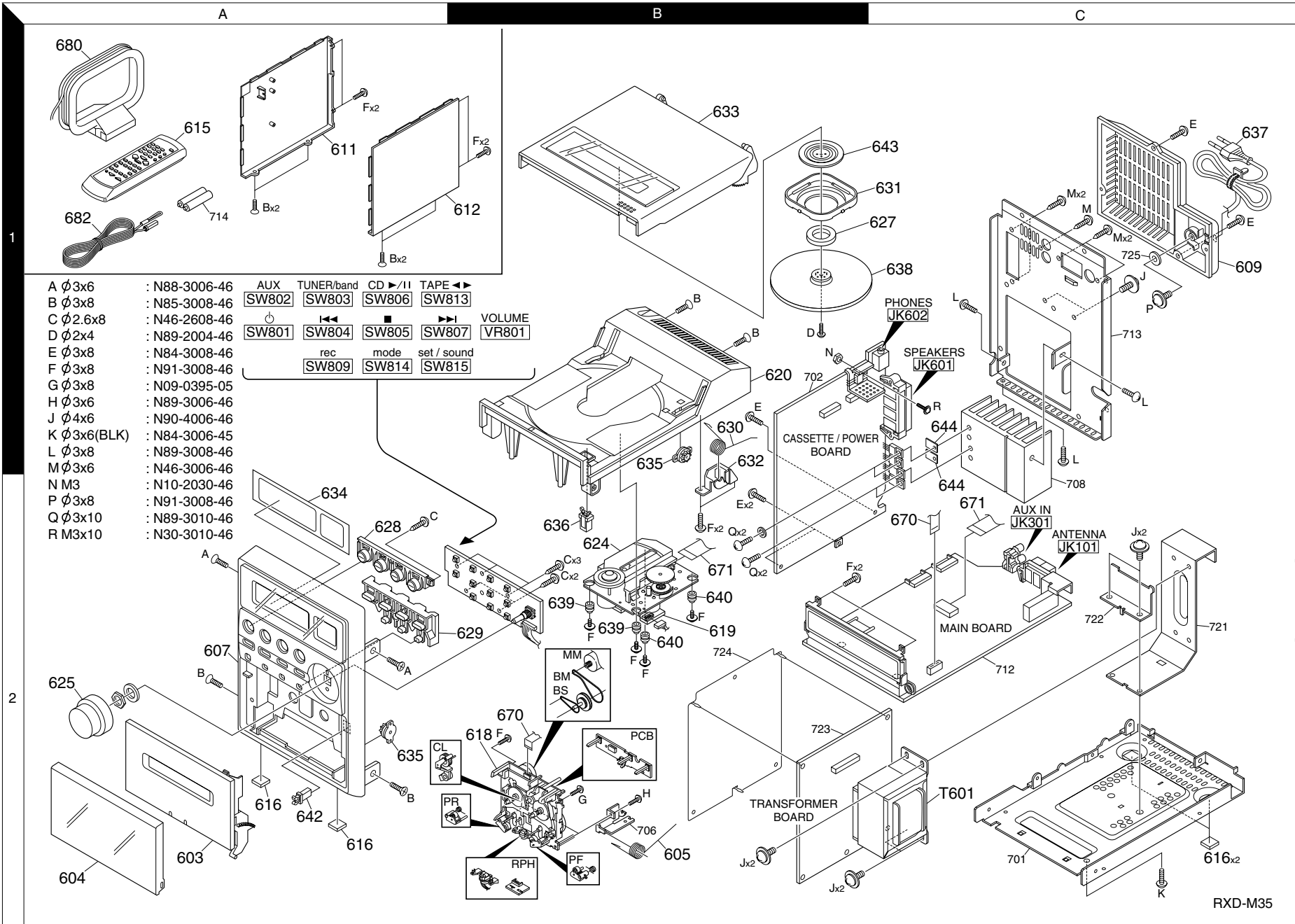

EXPLODED VIEW (UNIT)

RXD-M35

RXD-M35

* New Parts
Parts without **Parts No.** are not supplied.
Les articles non mentionnés dans le **Parts No.** ne sont pas fournis.
Teile ohne **Parts No.** werden nicht geliefert.

①

Ref. No	Add-ress	New Parts	Parts No.	Description	Desti-nation	Re-marks
LS-M35						
-		*	B06-2032-08	GRILLE ASSY SPK-NET-ASSY-LSF	F30	
-		*	B06-2031-08	GRILLE ASSY SPK-NET-ASSY-N		
-		*	B06-2030-08	GRILLE ASSY SPK-NET-ASSY-S		
-		*	H50-4640-08	SPK. CTN."KENW 153-03350-	SLV	
-		*	H50-4641-08	SPK. CTN."KENW 153-03350-1266	GLD	
-		*	H50-4642-08	SPK. CTN."KENW 153-03350-2266	F30	
-		*	H50-4690-08	SPK. CTN."KENW 153-03350-	H	
SP1		*	T07-0918-08	4" SPK. 6 OHM 029-10006-552		
RXD-M35						
-			H25-1749-08	POLYBAG 10X13 150-10013-510	NE	
-			H25-1750-08	POLYBAG 16X18 150-16018-510	E2STSX	
-		*	B60-5313-08	INST.BOOK(EN) 152-03350-0266	SKE3NT	
-		*	B60-5313-08	INST.BOOK(EN) 152-03350-0266	NESE	
-		*	B60-5314-08	INST.BOOK(FR) 152-03354-0266		
-		*	B60-5315-08	INST.BOOK(GE) 152-03354-1266	NESE	
-		*	B60-5316-08	INST.BOOK(NE) 152-03354-2266	NESE	
-		*	B60-5317-08	INST.BOOK(IT) 152-03354-3266	NESE	
-		*	B60-5318-08	INST.BOOK(ES) 152-03354-4266	NESE	
-		*	B60-5319-08	INST.BOOK(PL) 152-03356-0266	E2E3	
-		*	B60-5320-08	INST.BOOK(HU) 152-03356-1266	E2E3	
-		*	B60-5321-08	INST.BOOK(CZ) 152-03356-2266	E2E3	
-		*	B60-5322-08	INST.BOOK(RU) 152-03356-3266	E2E3	
-			H25-1649-08	POLYBAG 6X10 W 150-06010-210		
-			H25-1660-08	POLYBAG 16X20 150-16020-510		
-		*	H50-4631-08	ITEM CARTON RXD-M35-S	SE	
-		*	H50-4632-08	ITEM CARTON RXD-M35-S	E2	
-		*	H50-4633-08	ITEM CARTON RXD-M35-S	ST	
-		*	H50-4634-08	ITEM CARTON RXD-M35-N	NE	
-		*	H50-4635-08	ITEM CARTON RXD-M35-N	E3	
-		*	H50-4636-08	ITEM CARTON RXD-M35-N	NT	
-		*	H50-4691-08	ITEM CARTON RXD-M35-N	H	
-		*	H60-1199-08	CARTON CASE HM-335-S	SKSX	
603	2A	*	A53-2345-08	CASS.DOOR (ORA 110-03350-101		
604	2A	*	B10-3901-08	CASS.DOOR LENS 116-03350-001	SEE2ST	
604	2A	*	B10-3901-08	CASS.DOOR LENS 116-03350-001	SKSX	
604	2A	*	B10-3902-08	CASS.DOOR LENS 116-03350-002	H	
604	2A	*	B10-3902-08	CASS.DOOR LENS 116-03350-002	NEE3NT	
605	2B	*	G01-4347-08	CASSETTE DOOR 133-03353-308		
607	2A	*	A60-2310-08	F.CAB.ASSY(W/O M35S-FCSA-EE2T	SEE2ST	
607	2A	*	A60-2311-08	F.CAB.ASSY(W/O M35S-FCSA-XV	SX	
607	2A	*	A60-2312-08	F.CAB. ASSY (W M35S-FCSA-K	SK	
607	2A	*	A60-2313-08	F.CAB. ASSY (W M35N-FCSA-EE2T	H	
609	1C	*	F07-1799-08	F.CAB. ASSY (W M35N-FCSA-EE2T	NEE3NT	
611	1A	*	A50-1409-08	HEATSINK COVER 129-03359-6956		
611	1A	*	A50-1409-08	LEFT SIDE PLAT 109-03351-0956	NTH	
611	1A	*	A50-1409-08	LEFT SIDE PLAT 109-03351-0956	SEE2ST	
611	1A	*	A50-1409-08	LEFT SIDE PLAT 109-03351-0956	SXNEE3	
611	1A	*	A50-1411-08	LEFT SIDE PLAT 109-03353-0956	SK	
612	1B	*	A50-1408-08	RIGHT SIDE PLA 109-03350-0956	NTH	
612	1B	*	A50-1408-08	RIGHT SIDE PLA 109-03350-0956	SEE2ST	
612	1B	*	A50-1408-08	RIGHT SIDE PLA 109-03350-0956	SXNEE3	
612	1B	*	A50-1410-08	RIGHT SIDE PLA 109-03352-0956	SK	
615	1A	*	A70-1568-05	REMOTE HANDSET 182-03350-002	H	

L : Scandinavia K : USA P : Canada R : Mexico C : China I : Malaysia
Y : PX(Far East,Hawaii) T : England E : Europe G : Germany V : China(Shanghai)
Y : AAFES(Europe) X : Australia Q : Russia H : Korea M : Other Areas Δ indicates safety critical components.

* New Parts
Parts without **Parts No.** are not supplied.
Les articles non mentionnés dans le **Parts No.** ne sont pas fournis.
Teile ohne **Parts No.** werden nicht geliefert.

②

Ref. No	Add-ress	New Parts	Parts No.	Description	Desti-nation	Re-marks
615	1A		A70-1568-05	REMOTE HANDSET 182-03350-002	NENTST	
615	1A		A70-1568-05	REMOTE HANDSET 182-03350-002	SEE2E3	
615	1A		A70-1569-05	REMOTE HANDSET 182-03350-001	SKSX	
616	2A,2C	*	G11-2919-08	RUBBER FOOT (7 136-07503-750		
618	2B		D40-1772-05	SINGLE LOGIC D 141-01227-211		
619	2B		D40-1640-05	SONY CD MECHAN 160-00213-000		
620	1B	*	A02-3063-08	TOP CABINET (L 103-03350-0902	NTH	
620	1B	*	A02-3063-08	TOP CABINET (L 103-03350-0902	SEE2ST	
620	1B	*	A02-3063-08	TOP CABINET (L 103-03350-0902	SXNEE3	
620	1B	*	A02-3064-08	TOP CAB. (L.GR 103-03351-0902	SK	
624	2B		F07-1688-08	9829 CD COVER 161-00213-202		
625	2A	*	K29-8258-08	VOLUME KNOB (C 127-03351-013		
627	1C	*	T99-0624-08	MAGNET "NMB" F 161-00090-030		
628	2A	*	K29-8259-08	BUTTON SET-A (128-03352-1902		
629	2B	*	K29-8260-08	BUTTON SET-B (128-03352-2902		
630	1B	*	G01-4346-08	DOOR SPRING (S 162-03350-312		
631	1C	*	F07-1800-08	MAGNET HOLDER 129-03350-0956		
632	1B	*	J19-6382-08	SPRING HOLDER 129-03350-000		
633	1B	*	F07-1797-08	DOOR ASSY(L.GR M35S-CDDSA-00	SEE2ST	
633	1B	*	F07-1797-08	DOOR ASSY(L.GR M35S-CDDSA-00	SKSX	
633	1B	*	F07-1798-08	DOOR ASSY(L.GR M35N-CDDSA-00	H	
633	1B	*	F07-1798-08	DOOR ASSY(L.GR M35N-CDDSA-00	NEE3NT	
634	2A	*	B11-1567-08	FL FILTER (MIT 125-03352-000		
635	2A,1B		D39-0345-08	OIL DAMPER SET 130-03313-010		
636	2B		J52-0045-08	LATCH W/PUSH L 020-41100-900		
Δ 637	1C	*	E30-7295-08	AC CORD SAA AP 023-60080-002		
Δ 637	1C	*	E30-7296-08	AC CORD UL APP 023-60040-012		
Δ 637	1C	*	E30-7293-08	AC CORD VDE AP 023-65020-300		
Δ 637	1C	*	E30-7293-08	AC LINE CORD V		
Δ 637	1C	*	E30-7294-08	AC LINE CORD V 023-60040-004		
Δ 637	1C	*	E30-7298-08	AC LINE CORD V 023-60110-301	H	
638	1C		F07-2001-08	213CDM CD MAGN 161-00213-206		
639	2B		J02-1545-08	HARD RUBBER NO 161-05117-101		
640	2B		J02-1546-08	SOFT RUBBER NO 161-05116-001		
642	2A		D32-0368-08	CD LOCKER PLAS 130-10618-200		
643	1C		J21-6982-08	SANYO CD MAGNE 161-00011-203		
644	1C	*	F20-3606-08	HEAT PATH GTQ- 136-90000-003		
670	2B,2C	*	E35-3530-08	8P FILM CONNEX 037-44211-085		
671	2B,2C	*	E35-2578-08	16P FILM TYPE 037-45101-164		
680	1A		T90-0846-08	AM LOOP ANTENN 015-82100-001		
682	1A		T90-0861-08	1P J.WIRE #26U 025-10001-003		
CASSETTE (D40-1772-05)						
BM	2B		D16-0748-08	MAIN BLT FF19U-21		
BS	2B		D16-0749-08	F/R BELT FF19S-31		
CL	2B	*	D19-0331-08	CLUTCH ASSY F522-060		
PF	2B		D14-0399-08	ROLLER PINCH R F514-133		
PR	2B		D14-0400-08	ROLLER PINCH L F514-134		
MM	2B	*	T42-1122-08	MTR MAIN BLK F525-345		
RPB	2B		T39-0041-08	PLATE HD BLOCK F513-853		
PCB	2B		W02-2926-08	PCB CONTROL F567-689		
ELECTRONICS PARTS						
C101			CK73GB1H103K	CHIP C 0.010UF	K	

L : Scandinavia K : USA P : Canada R : Mexico C : China I : Malaysia
Y : PX(Far East,Hawaii) T : England E : Europe G : Germany V : China(Shanghai)
Y : AAFES(Europe) X : Australia Q : Russia H : Korea M : Other Areas Δ indicates safety critical components.

* New Parts
 Parts without **Parts No.** are not supplied.
 Les articles non mentionnés dans le **Parts No.** ne sont pas fournis.
 Teile ohne **Parts No.** werden nicht geliefert.



Ref. No	Add-ress	New Parts	Parts No.	Description	Desti-nation	Re-marks
C102			CE04LW1H100M	ELECTRO	10UF	50WV
C103,104			CK73GB1H103K	CHIP C	0.010UF	K
C105			CC73GCH1H470J	CHIP C	47PF	J
C106			CK73GB1H223K	CHIP C	0.022UF	K
C107			CC73GCH1H070C	CHIP C	7.0PF	C
C108			CK73GB1H431K	CHIP C	430PF	K
C109			CK73GB1H473K	CHIP C	0.047UF	K
C110			CK73GB1H105Z	CHIP C	1.0UF	Z
C111			CE04LW1H100M	ELECTRO	10UF	50WV
C114			CE04LW1H3R3M	ELECTRO	3.3UF	50WV
C115			CK73GB1H102K	CHIP C	1000PF	K
C115			CK73GB1H102K	CHIP C	1000PF	K
C115			CK73GB1H102K	CHIP C	1000PF	K
C117			CK73GB1H151J	CHIP C	150PF	J
C118			CK73GB1H221K	CHIP C	220PF	K
C118			CK73GB1H221K	CHIP C	220PF	K
C118			CK73GB1H471K	CHIP C	470PF	K
C119			CK73GB1H333K	CHIP C	0.033UF	K
C120			CE04BP1H100M	NP-ELEC	10UF	50WV
C122,123			CK73GB1H153K	CHIP C	0.015UF	K
C122,123			CK73GB1H153K	CHIP C	0.015UF	K
C122,123			CK73GB1H153K	CHIP C	0.015UF	K
C122,123			CK73GB1H223K	CHIP C	0.022UF	K
C124			CK73GB1H821K	CHIP C	820PF	K
C125,126			CE04LW1H100M	ELECTRO	10UF	50WV
C127			CE04LW1H470M	ELECTRO	47UF	50WV
C128			CK73GB1H473K	CHIP C	0.047UF	K
C129,130			CK73GB1H103K	CHIP C	0.010UF	K
C131			CE04LW1H101M	ELECTRO	100UF	50WV
C135			CK73GB1H101J	CHIP C	100PF	J
C136			CE04LW1HR47M	ELECTRO	0.47UF	50WV
C137,138			CE04LW1H010M	ELECTRO	1.0UF	50WV
C139			CK73GB1H101J	CHIP C	100PF	J
C140			CK73GB1H103K	CHIP C	0.010UF	K
C141			CE04LW1H3R3M	ELECTRO	3.3UF	50WV
C142,143			CE04LW1H470M	ELECTRO	47UF	50WV
C144,145			CC73GCH1H270J	CHIP C	27PF	J
C147			CE04LW1H470M	ELECTRO	47UF	50WV
C147			CE04LW1H470M	ELECTRO	47UF	50WV
C147			CE04LW1H470M	ELECTRO	47UF	50WV
C148			CE04LW1H470M	ELECTRO	47UF	50WV
C148			CE04LW1H470M	ELECTRO	47UF	50WV
C148			CE04LW1H470M	ELECTRO	47UF	50WV
C148			CE04LW1H470M	ELECTRO	47UF	50WV
C149			CK73GB1H271K	CHIP C	270PF	K
C149			CK73GB1H271K	CHIP C	270PF	K
C149			CK73GB1H271K	CHIP C	270PF	K
C150			CK73GB1H561K	CHIP C	560PF	K
C150			CK73GB1H561K	CHIP C	560PF	K
C150			CK73GB1H561K	CHIP C	560PF	K
C151			CC73GCH1H330J	CHIP C	33PF	J
C151			CC73GCH1H330J	CHIP C	33PF	J
C151			CC73GCH1H330J	CHIP C	33PF	J
C152			CC73GCH1H390J	CHIP C	39PF	J
C152			CC73GCH1H390J	CHIP C	39PF	J

L : Scandinavia K : USA P : Canada R : Mexico C : China I : Malaysia
 Y : PX(Far East,Hawaii) T : England E : Europe G : Germany V : China(Shanghai)
 Y : AAFES(Europe) X : Australia Q : Russia H : Korea M : Other Areas Δ indicates safety critical components.

* New Parts
 Parts without **Parts No.** are not supplied.
 Les articles non mentionnés dans le **Parts No.** ne sont pas fournis.
 Teile ohne **Parts No.** werden nicht geliefert.



Ref. No	Add-ress	New Parts	Parts No.	Description	Desti-nation	Re-marks
C152			CC73GCH1H390J	CHIP C	39PF	J
C157			CE04BP1H4R7M	NP-ELEC	4.7UF	50WV
C158			CK73GB1H104K	CHIP C	0.10UF	K
C159			CK73GB1H472K	CHIP C	4700PF	K
C201-203			CE04LW1H101M	ELECTRO	100UF	50WV
C204			CK73GB1H471K	CHIP C	470PF	K
C205-207			CK73GB1H104K	CHIP C	0.10UF	K
C208			CK73GB1H392K	CHIP C	3900PF	K
C209			CC73GCH1H050C	CHIP C	5.0PF	C
C210			CK73GB1H471K	CHIP C	470PF	K
C211			CK73GB1H332K	CHIP C	3300PF	K
C212			CK73GB1H471K	CHIP C	470PF	K
C213			CC73GCH1H820J	CHIP C	82PF	J
C214			CK73GB1H104K	CHIP C	0.10UF	K
C215			CK73GB1H224K	CHIP C	0.22UF	K
C216			CK73GB1H393K	CHIP C	0.039UF	K
C217			CK73GB1H472K	CHIP C	4700PF	K
C218			CK73GB1H471K	CHIP C	470PF	K
C219			CK73GB1H221K	CHIP C	220PF	K
C220			CK73GB1H102K	CHIP C	1000PF	K
C221			CK73GB1H101J	CHIP C	100PF	J
C222			CK73GB1H221K	CHIP C	220PF	K
C223			CK73GB1H223K	CHIP C	0.022UF	K
C224			CE04LW1H471M	ELECTRO	47UF	50WV
C225			CK73GB1H332K	CHIP C	3300PF	K
C227			CK73GB1H223K	CHIP C	0.022UF	K
C228			CK73GB1H102K	CHIP C	1000PF	K
C229,230			CK73GB1H223K	CHIP C	0.022UF	K
C231			CK73GB1H224K	CHIP C	0.22UF	K
C232			CK73GB1H122K	CHIP C	1200PF	K
C233			CK73GB1H102K	CHIP C	1000PF	K
C234			CK73GB1H473K	CHIP C	0.047UF	K
C235			CK73GB1H334K	CHIP C	0.33UF	K
C237,238			CK73GB1H102K	CHIP C	1000PF	K
C241,242			CE04LW1H100M	ELECTRO	10UF	50WV
C243,244			CK73GB1H221K	CHIP C	220PF	K
C256			CE04LW1E471M	ELECTRO	47UF	25WV
C257			CE04LW1A221M	ELECTRO	220UF	10WV
C267,268			CK73GB1H681K	CHIP C	680PF	K
C270			CK73GB1H473K	CHIP C	0.047UF	K
C271,272			CK73GB1H221K	CHIP C	220PF	K
C301,302			CE04LW1H100M	ELECTRO	10UF	50WV
C303			CK73GB1H221K	CHIP C	220PF	K
C303,304			CK73GB1H272K	CHIP C	2700PF	K
C305-308			CK73GB1H154K	CHIP C	0.15UF	K
C309,310			CK73GB1H221K	CHIP C	220PF	K
C311			CK73GB1H471K	CHIP C	470PF	K
C312			CE04LW1H470M	ELECTRO	47UF	50WV
C313			CK73GB1H473K	CHIP C	0.047UF	K
C313,314			CE04LW1H2R2M	ELECTRO	2.2UF	50WV
C328			CE04LW1H101M	ELECTRO	100UF	50WV
C331,332			CE04LW1H100M	ELECTRO	10UF	50WV
C335,336			CE04LW1H2R2M	ELECTRO	2.2UF	50WV
C337,338			CK73GB1H221K	CHIP C	220PF	K
C401			CK73GB1H101J	CHIP C	100PF	J

L : Scandinavia K : USA P : Canada R : Mexico C : China I : Malaysia
 Y : PX(Far East,Hawaii) T : England E : Europe G : Germany V : China(Shanghai)
 Y : AAFES(Europe) X : Australia Q : Russia H : Korea M : Other Areas Δ indicates safety critical components.

PARTS LIST

RXD-M35

* New Parts
Parts without **Parts No.** are not supplied.
Les articles non mentionnés dans le **Parts No.** ne sont pas fournis.
Teile ohne **Parts No.** werden nicht geliefert.

5

Ref. No	Add-ress	New Parts	Parts No.	Description	Desti-nation	Re-marks
C402-405 C406 C407,408 C409-411 C412,413			CK73GB1H103K CK73GB1H101J CC73GCH1H180J CK73GB1H103K CK73GB1H101J	CHIP C CHIP C CHIP C CHIP C CHIP C	0.010UF 100PF 18PF 0.010UF 100PF	K J J K J
C414A,B C416 C417 C418,419 C601,602			CK73GB1H105Z CK73GB1H103K CK73GB1H105Z CE04LW1H101M CE04LW1H2R2M	CHIP C CHIP C CHIP C ELECTRO ELECTRO	1.0UF 0.010UF 1.0UF 100UF 2.2UF	Z K Z 50WV 50WV
C603,604 C605,606 C607-610 C611,612 C613-615			CK73GB1H221K CE04LW1H470M CK45FB1H224Z CC73GCH1H470J CE04LW1E222M	CHIP C ELECTRO CERAMIC CHIP C ELECTRO	220PF 47UF 0.22UF 47PF 2200UF	K 50WV Z J 25WV
C616 C617,618 C621,622 C625 C627			CE04BP1H100M CK45FB1H103K CE04LW1J101M CE04LW1H101M CK45FB1H103K	NP-ELEC CERAMIC ELECTRO ELECTRO CERAMIC	10UF 0.010UF 100UF 100UF 0.010UF	50WV K 63WV 50WV K
C628 C629 C631 C632,633 C635			CE04LW1E222M CE04BP1E220M CK73GB1H683K CK45FB1H103K C91-1439-05	ELECTRO NP-ELEC CHIP C CERAMIC FILM	2200UF 22UF 0.068UF 0.010UF 0.010UF	25WV 25WV K K 250VAC
C637,638 C641,642 C643,644 C645 C646			CE04LW1H101M CK73GB1H102K CK73GB1H473K CK45FB1H103K CE04LW1H100M	ELECTRO CHIP C CHIP C CERAMIC ELECTRO	100UF 1000PF 0.047UF 0.010UF 10UF	50WV K K K 50WV
C701,702 C703,704 C705 C707,708 C709,710			CK73GB1H271K CK73GB1H101J CK73GB1H223K CE04LW1H101M CK73GB1H273K	CHIP C CHIP C CHIP C ELECTRO CHIP C	270PF 100PF 0.022UF 100UF 0.027UF	K J K 50WV K
C711,712 C713,714 C715,716 C717,718 C721,722			CE04LW1H4R7M CE04LW1H100M CK73GB1H122K CK45FB1H102K CK45FB1H221J	ELECTRO ELECTRO CHIP C CERAMIC CERAMIC	4.7UF 10UF 1200PF 1000PF 220PF	50WV 50WV K K J
C723 C724 C725 C727,728 C729			CK73GB1H393K CE04LW1H100M CE04LW1H101M CE04LW1H2R2M CQ92M1H682K	CHIP C ELECTRO ELECTRO ELECTRO MYLAR	0.039UF 10UF 100UF 2.2UF 6800PF	K 50WV 50WV 50WV K
C730 C731,732 C733 C734 C735			CE04LW1H100M CK45FB1H221J CK73GB1H822K CK73GB1H103K CE04LW1H220M	ELECTRO CERAMIC CHIP C CHIP C ELECTRO	10UF 220PF 8200PF 0.010UF 22UF	50WV J K K 50WV
C736 C737 C741,742 C745 C801			CE04LW1H100M CK73GB1H822K CE04LW1H4R7M CE04LW1H4R7M CK73GB1H105Z	ELECTRO CHIP C ELECTRO ELECTRO CHIP C	10UF 8200PF 4.7UF 4.7UF 1.0UF	50WV K 50WV 50WV Z

L : Scandinavia K : USA P : Canada R : Mexico C : China I : Malaysia
Y : PX(Far East,Hawaii) T : England E : Europe G : Germany V : China(Shanghai)
Y : AAFES(Europe) X : Australia Q : Russia H : Korea M : Other Areas Δ indicates safety critical components.

* New Parts
Parts without **Parts No.** are not supplied.
Les articles non mentionnés dans le **Parts No.** ne sont pas fournis.
Teile ohne **Parts No.** werden nicht geliefert.

6

Ref. No	Add-ress	New Parts	Parts No.	Description	Desti-nation	Re-marks
C802,803 C804 C805,806 TC101			CK73GB1H221K CE04LW1H470M CE04LW1H010M C05-0301-05	CHIP C ELECTRO ELECTRO TRIMMER	220PF 47UF 1.0UF 7 PF 6 014-10070-001	K 50WV 50WV
CN201 CN402 JK101 JK301 JK601			E40-4997-05 E40-4895-05 E70-0112-08 E63-1091-08 E70-0113-08	16P ZIP R/A CO 025-20016-305 8P FCC CONNECT 025-20008-206 SPK. TERMINAL 046-10300-002 RCA JACK RS-24 046-20200-008 SPK TERMINAL P 046-10400-009		
JK602			E11-0398-08	STEREO JACK 3. 021-23507-100		
Δ F601 Δ F601 Δ F601 Δ F601			F05-2029-05 F05-2029-05 F05-2029-05 F50-0062-05	2A/250V FAST A 050-05020-210 2A/250V FAST A 050-05020-210 2A/250V FAST A 050-05020-210 0.8A/250V FAST 050-05020-082		NESEH NTST SXE2E3 SK
CF101,102 CF101,102 CF101,102 CF101,102 CF103			L72-0536-05 L72-0536-05 L72-0536-05 L72-0632-08 L72-0633-08	CERAMIC FILTER 028-10700-023 CERAMIC FILTER 028-10700-023 CERAMIC FILTER 028-10700-023 CERAMIC FILTER 028-10700-028 CERAMIC FILTER 028-00450-004		E2E3 NESEH NTST SK
L101 L102 L201 L701,702 T101			L40-2291-17 L33-1648-08 L33-1648-08 L33-1647-08 L31-0640-08	INDUCTOR 2.2 U 015-70022-007 INDUCTOR 10 UH 015-70100-007 INDUCTOR 10 UH 015-70100-007 INDUCTOR 10 MH 015-70103-006 AM ANT. 7MM OH 016-21032-104		
T102 T103 T104 Δ T601 Δ T601			L32-1018-08 L30-0977-08 L30-0991-08 * L07-3245-08 * L07-3246-08	OSC 7MM NO.036 016-20360-023 IFT 7MM RD157- 016-21198-101 FM IFT 7MM OH- 016-22372-102 X'FORMER T66-0 018-03357-562 X'FORMER T66-0 018-03357-572		SE E2E3
Δ T601 Δ T601 Δ T601 Δ T602 Δ T701			* L07-3246-08 * L07-3246-08 * L07-3247-08 * L07-3248-08 * L32-1059-08	X'FORMER T66-0 018-03357-572 X'FORMER T66-0 018-03357-572 X'FORMER T66-0 018-03357-522 X'FORMER T28-0 018-03352-560 BIAS TRAP. COI 016-00592-105		NESXH NTST SK
X101 X102 X102 X102 X201			* L77-2405-08 * L77-2406-08 * L77-2406-08 * L77-2406-08 * L78-0759-08	CRYSTAL: 7.2 M 052-07200-005 CRYSTAL: 4.332 052-04332-002 CRYSTAL: 4.332 052-04332-002 CRYSTAL: 4.332 052-04332-002 CERAMIC RESONA 052-16930-104		E2E3 NESEH NTST
X401 X402 X801			* L77-2264-08 * L78-0760-08 L77-2266-08	CRYSTAL : 32.7 052-32768-000 CERAMIC RESONA 052-08390-100 4MC CERAMIC RE 052-04000-102		
R101 R102 R103 R104 R105,106			RK73GB1J221J RK73GB1J681J RK73GB1J332J J RK73GB1J100J RK73GB1J331J	CHIP R CHIP R CHIP R CHIP R CHIP R	220 680 3.3K 10 330	J J J J J 1/16W 1/16W 1/16W 1/16W 1/16W
R107 R108 R109 R110 R111			RK73GB1J101J RK73GB1J100J RK73GB1J000J RK73GB1J102J RK73GB1J473J	CHIP R CHIP R CHIP R CHIP R CHIP R	100 10 0 1.0K 47K	J J J J J 1/16W 1/16W 1/16W 1/16W 1/16W
R112 R113,114			RK73GB1J332J RK73GB1J223J	CHIP R CHIP R	3.3K 22K	J J 1/16W 1/16W

L : Scandinavia K : USA P : Canada R : Mexico C : China I : Malaysia
Y : PX(Far East,Hawaii) T : England E : Europe G : Germany V : China(Shanghai)
Y : AAFES(Europe) X : Australia Q : Russia H : Korea M : Other Areas Δ indicates safety critical components.

* New Parts
 Parts without **Parts No.** are not supplied.
 Les articles non mentionnés dans le **Parts No.** ne sont pas fournis.
 Teile ohne **Parts No.** werden nicht geliefert.

7

Ref. No	Add-ress	New Parts	Parts No.	Description	Desti-nation	Re-marks
R115			RK73GB1J472J	CHIP R	4.7K	J 1/16W
R118			RK73GB1J562J	CHIP R	5.6K	J 1/16W
R120			RK73GB1J101J	CHIP R	100	J 1/16W
R122			RK73GB1J332J	CHIP R	3.3K	J 1/16W
R123			RK73GB1J182J	CHIP R	1.8K	J 1/16W
R124,125			RK73GB1J562J	CHIP R	5.6K	J 1/16W
R126			RK73GB1J123J	CHIP R	12K	J 1/16W
R127			RK73GB1J392J	CHIP R	3.9K	J 1/16W
R128,129			RK73GB1J102J	CHIP R	1.0K	J 1/16W
R130			RK73GB1J562J	CHIP R	5.6K	J 1/16W
R131			RK73GB1J102J	CHIP R	1.0K	J 1/16W
R132			RK73GB1J222J	CHIP R	2.2K	J 1/16W
R133			RK73GB1J103J	CHIP R	10K	J 1/16W
R134			RK73GB1J683J	CHIP R	68K	J 1/16W
R135			RK73GB1J103J	CHIP R	10K	J 1/16W
R136			RK73GB1J102J	CHIP R	1.0K	J 1/16W
R137-139			RK73GB1J332J	CHIP R	3.3K	J 1/16W
R140			RK73GB1J100J	CHIP R	10	J 1/16W
R141			RK73GB1J100J	CHIP R	10	J 1/16W
R141			RK73GB1J100J	CHIP R	10	J 1/16W
R141			RK73GB1J100J	CHIP R	10	J 1/16W
R142			RK73GB1J473J	CHIP R	47K	J 1/16W
R142			RK73GB1J473J	CHIP R	47K	J 1/16W
R142			RK73GB1J473J	CHIP R	47K	J 1/16W
R143,144			RK73GB1J102J	CHIP R	1.0K	J 1/16W
R143,144			RK73GB1J102J	CHIP R	1.0K	J 1/16W
R145			RK73GB1J473J	CHIP R	47K	J 1/16W
R146			RK73GB1J102J	CHIP R	1.0K	J 1/16W
R146			RK73GB1J102J	CHIP R	1.0K	J 1/16W
R147			RK73GB1J473J	CHIP R	47K	J 1/16W
R148			RK73GB1J392J	CHIP R	3.9K	J 1/16W
R149			RK73GB1J222J	CHIP R	2.2K	J 1/16W
R150			RK73GB1J100J	CHIP R	10	J 1/16W
R152			RK73GB1J104J	CHIP R	100K	J 1/16W
R153,154			RK73GB1J102J	CHIP R	1.0K	J 1/16W
R160,161			RK73GB1J103J	CHIP R	10K	J 1/16W
R160,161			RK73GB1J103J	CHIP R	10K	J 1/16W
R160,161			RK73GB1J103J	CHIP R	10K	J 1/16W
R162			RK73GB1J222J	CHIP R	2.2K	J 1/16W
R162			RK73GB1J222J	CHIP R	2.2K	J 1/16W
R162			RK73GB1J222J	CHIP R	2.2K	J 1/16W
R164			RK73GB1J223J	CHIP R	22K	J 1/16W
R164			RK73GB1J223J	CHIP R	22K	J 1/16W
R164			RK73GB1J223J	CHIP R	22K	J 1/16W
R165			RK73GB1J472J	CHIP R	4.7K	J 1/16W
R165			RK73GB1J472J	CHIP R	4.7K	J 1/16W
R165			RK73GB1J472J	CHIP R	4.7K	J 1/16W
R166			RK73GB1J272J	CHIP R	2.7K	J 1/16W
R166			RK73GB1J682J	CHIP R	6.8K	J 1/16W
R166			RK73GB1J682J	CHIP R	6.8K	J 1/16W
R166			RK73GB1J682J	CHIP R	6.8K	J 1/16W
R167			RK73GB1J473J	CHIP R	47K	J 1/16W
R168			RK73GB1J101J	CHIP R	100	J 1/16W
R201-204			RK73GB1J102J	CHIP R	1.0K	J 1/16W

L : Scandinavia K : USA P : Canada R : Mexico C : China I : Malaysia
 Y : PX(Far East,Hawaii) T : England E : Europe G : Germany V : China(Shanghai)
 Y : AAFES(Europe) X : Australia Q : Russia H : Korea M : Other Areas Δ indicates safety critical components .

* New Parts
 Parts without **Parts No.** are not supplied.
 Les articles non mentionnés dans le **Parts No.** ne sont pas fournis.
 Teile ohne **Parts No.** werden nicht geliefert.

8

Ref. No	Add-ress	New Parts	Parts No.	Description	Desti-nation	Re-marks
R205,206			RK73GB1J272J	CHIP R	2.7K	J 1/16W
R207			RK73GB1J333J	CHIP R	33K	J 1/16W
R208			RK73GB1J393J	CHIP R	39K	J 1/16W
R209			RK73GB1J4R7J	CHIP R	4.7	J 1/16W
R210			RK73GB1J433J	CHIP R	43K	J 1/16W
R211			RK73GB1J104J	CHIP R	100K	J 1/16W
R212			RK73GB1J334J	CHIP R	330K	J 1/16W
R213			RK73GB1J102J	CHIP R	1.0K	J 1/16W
R214			RK73GB1J220J	CHIP R	22	J 1/16W
R215			RK73GB1J393J	CHIP R	39K	J 1/16W
R217			RK73GB1J334J	CHIP R	330K	J 1/16W
R218			RK73GB1J104J	CHIP R	100K	J 1/16W
R220			RK73GB1J100J	CHIP R	10	J 1/16W
R221			RK73GB1J473J	CHIP R	47K	J 1/16W
R222			RK73GB1J182J	CHIP R	1.8K	J 1/16W
R223			RK73GB1J512J	CHIP R	5.1K	J 1/16W
R224			RK73GB1J272J	CHIP R	2.7K	J 1/16W
R225			RK73GB1J100J	CHIP R	10	J 1/16W
R226			RK73GB1J113J	CHIP R	11K	J 1/16W
R234			RK73GB1J102J	CHIP R	1.0K	J 1/16W
R238			RK73GB1J154J	CHIP R	150K	J 1/16W
R239			RK73GB1J563J	CHIP R	56K	J 1/16W
R240			RK73GB1J101J	CHIP R	100	J 1/16W
R241			RK73GB1J104J	CHIP R	100K	J 1/16W
R242			RK73GB1J103J	CHIP R	10K	J 1/16W
R243			RK73GB1J274J	CHIP R	270K	J 1/16W
R244			RK73GB1J183J	CHIP R	18K	J 1/16W
R245			RK73GB1J124J	CHIP R	120K	J 1/16W
R247			RK73GB1J682J	CHIP R	6.8K	J 1/16W
R248			RK73GB1J102J	CHIP R	1.0K	J 1/16W
R249			RK73GB1J473J	CHIP R	47K	J 1/16W
R250			RK73GB1J563J	CHIP R	56K	J 1/16W
R251			RK73GB1J104J	CHIP R	100K	J 1/16W
R252			RK73GB1J333J	CHIP R	33K	J 1/16W
R253			RK73GB1J105J	CHIP R	1.0M	J 1/16W
R254			RK73GB1J331J	CHIP R	330	J 1/16W
R255			RK73GB1J100J	CHIP R	10	J 1/16W
R256			RK73GB1J272J	CHIP R	2.7K	J 1/16W
R257			RK73GB1J4R7J	CHIP R	4.7	J 1/16W
R258			RK73GB1J105J	CHIP R	1.0M	J 1/16W
R259			RK73GB1J102J	CHIP R	1.0K	J 1/16W
R260			RK73GB1J4R7J	CHIP R	4.7	J 1/16W
R261			RK73GB1J393J	CHIP R	39K	J 1/16W
R262			RD14BB2H4R7J	RD	4.7	J 1/2W
R269,270			RK73GB1J103J	CHIP R	10K	J 1/16W
R274			RK73GB1J103J	CHIP R	10K	J 1/16W
R301,302			RK73GB1J362J	CHIP R	3.6K	J 1/16W
R322-324			RK73GB1J102J	CHIP R	1.0K	J 1/16W
R333,334			RK73GB1J333J	CHIP R	33K	J 1/16W
R335,336			RK73GB1J223J	CHIP R	22K	J 1/16W
R401-405			RK73GB1J101J	CHIP R	100	J 1/16W
R406-409			RK73GB1J472J	CHIP R	4.7K	J 1/16W
R410			RK73GB1J473J	CHIP R	47K	J 1/16W
R411			RK73GB1J472J	CHIP R	4.7K	J 1/16W
R412-415			RK73GB1J473J	CHIP R	47K	J 1/16W

L : Scandinavia K : USA P : Canada R : Mexico C : China I : Malaysia
 Y : PX(Far East,Hawaii) T : England E : Europe G : Germany V : China(Shanghai)
 Y : AAFES(Europe) X : Australia Q : Russia H : Korea M : Other Areas Δ indicates safety critical components .

PARTS LIST

RXD-M35

* New Parts
 Parts without **Parts No.** are not supplied.
 Les articles non mentionnés dans le **Parts No.** ne sont pas fournis.
 Teile ohne **Parts No.** werden nicht geliefert.

9

Ref. No	Add-ress	New Parts	Parts No.	Description	Desti-nation	Re-marks
R416,417			RK73GB1J472J	CHIP R	4.7K	J 1/16W
R418			RK73GB1J1R0J	CHIP R	1	J 1/16W
R419			RK73GB1J473J	CHIP R	47K	J 1/16W
R420			RK73GB1J1R0J	CHIP R	1	J 1/16W
R421			RK73GB1J104J	CHIP R	100K	J 1/16W
R422			RK73GB1J332J	CHIP R	3.3K	J 1/16W
R424			RK73GB1J101J	CHIP R	100	J 1/16W
R425			RK73GB1J104J	CHIP R	100K	J 1/16W
R426,427			RK73GB1J101J	CHIP R	100	J 1/16W
R428,429			RK73GB1J104J	CHIP R	100K	J 1/16W
R430			RK73GB1J104J	CHIP R	100K	J 1/16W
R431			RK73GB1J103J	CHIP R	10K	J 1/16W
R432			RK73GB1J104J	CHIP R	100K	J 1/16W
R433			RK73GB1J101J	CHIP R	100	J 1/16W
R434			RK73GB1J104J	CHIP R	100K	J 1/16W
R435,436			RK73GB1J102J	CHIP R	1.0K	J 1/16W
R437			RK73GB1J101J	CHIP R	100	J 1/16W
R438			RK73GB1J102J	CHIP R	1.0K	J 1/16W
R439			RK73GB1J104J	CHIP R	100K	J 1/16W
R440-442			RK73GB1J473J	CHIP R	47K	J 1/16W
R443			RK73GB1J104J	CHIP R	100K	J 1/16W
R444			RK73GB1J102J	CHIP R	1.0K	J 1/16W
R445			RK73GB1J104J	CHIP R	100K	J 1/16W
R447			RK73GB1J101J	CHIP R	100	J 1/16W
R448			RK73GB1J103J	CHIP R	10K	J 1/16W
R449			RK73GB1J104J	CHIP R	100K	J 1/16W
R450,451			RK73GB1J101J	CHIP R	100	J 1/16W
R452			RK73GB1J224J	CHIP R	220K	J 1/16W
R452			RK73GB1J224J	CHIP R	220K	J 1/16W
R452			RK73GB1J272J	CHIP R	2.7K	J 1/16W
R453			RK73GB1J104J	CHIP R	100K	J 1/16W
R454			RK73GB1J101J	CHIP R	100	J 1/16W
R455			RK73GB1J103J	CHIP R	10K	J 1/16W
R456-460			RK73GB1J101J	CHIP R	100	J 1/16W
R461			RK73GB1J104J	CHIP R	100K	J 1/16W
R462-465			RK73GB1J473J	CHIP R	47K	J 1/16W
R466-468			RK73GB1J101J	CHIP R	100	J 1/16W
R470			RK73GB1J332J	CHIP R	3.3K	J 1/16W
R472			RK73GB1J332J	CHIP R	3.3K	J 1/16W
R473			RK73GB1J101J	CHIP R	100	J 1/16W
R475			RK73GB1J101J	CHIP R	100	J 1/16W
R476			RK73GB1J473J	CHIP R	47K	J 1/16W
R478,479			RK73GB1J512J	CHIP R	5.1K	J 1/16W
R480			RK73GB1J104J	CHIP R	100K	J 1/16W
R481			RK73GB1J102J	CHIP R	1.0K	J 1/16W
R482,483			RK73GB1J103J	CHIP R	10K	J 1/16W
R484,485			RK73GB1J101J	CHIP R	100	J 1/16W
R486			RK73GB1J102J	CHIP R	1.0K	J 1/16W
R487,488			RK73GB1J101J	CHIP R	100	J 1/16W
R490			RK73GB1J102J	CHIP R	1.0K	J 1/16W
R492,493			RK73GB1J101J	CHIP R	100	J 1/16W
R494			RK73GB1J102J	CHIP R	1.0K	J 1/16W
R498,499			RK73GB1J101J	CHIP R	100	J 1/16W
R601,602			RK73GB1J102J	CHIP R	1.0K	J 1/16W

L : Scandinavia K : USA P : Canada R : Mexico C : China I : Malaysia
 Y : PX(Far East,Hawaii) T : England E : Europe G : Germany V : China(Shanghai)
 Y : AAFES(Europe) X : Australia Q : Russia H : Korea M : Other Areas Δ indicates safety critical components.

* New Parts
 Parts without **Parts No.** are not supplied.
 Les articles non mentionnés dans le **Parts No.** ne sont pas fournis.
 Teile ohne **Parts No.** werden nicht geliefert.

10

Ref. No	Add-ress	New Parts	Parts No.	Description	Desti-nation	Re-marks
R603,604			RK73GB1J103J	CHIP R	10K	J 1/16W
R605,606			RK73GB1J222J	CHIP R	2.2K	J 1/16W
R607-610			RK73GB1J223J	CHIP R	22K	J 1/16W
R613,614			RK73GB1J391J	CHIP R	390	J 1/16W
R618			RK73GB1J223J	CHIP R	22K	J 1/16W
R619			RK73GB1J472J	CHIP R	4.7K	J 1/16W
R620			RK73GB1J223J	CHIP R	22K	J 1/16W
R621			RK73GB1J102J	CHIP R	1.0K	J 1/16W
R629			RK73GB1J473J	CHIP R	47K	J 1/16W
R630			RS14GB3A101J	FL-PROOF RS	100	J 1W
R631			R92-1844-05	CARBON	3.3M	J 1/2W SK
R639			RK73GB1J104J	CHIP R	100K	J 1/16W
R640			RK73GB1J223J	CHIP R	22K	J 1/16W
R641,642			RK73GB1J102J	CHIP R	1.0K	J 1/16W
R643			RK73GB1J472J	CHIP R	4.7K	J 1/16W
R644			RK73GB1J473J	CHIP R	47K	J 1/16W
R645			RK73GB1J101J	CHIP R	100	J 1/16W
R647,648			RK73GB1J271J	CHIP R	270	J 1/16W
R650,651			RK73GB1J101J	CHIP R	100	J 1/16W
R653,654			RK73GB1J102J	CHIP R	1.0K	J 1/16W
R655,656			RK73GB1J683J	CHIP R	68K	J 1/16W
R657,658			RS14GB3DR22J	FL-PROOF RS	0.22	J 2W
R659			RK73GB1J223J	CHIP R	22K	J 1/16W
R660,661			RK73GB1J103J	CHIP R	10K	J 1/16W
R701			RK73GB1J103J	CHIP R	10K	J 1/16W
R703,704			RK73GB1J102J	CHIP R	1.0K	J 1/16W
R705,706			RK73GB1J220J	CHIP R	22	J 1/16W
R707,708			RK73GB1J472J	CHIP R	4.7K	J 1/16W
R709,710			RK73GB1J153J	CHIP R	15K	J 1/16W
R711-713			RK73GB1J102J	CHIP R	1.0K	J 1/16W
R719,720			RK73GB1J183J	CHIP R	18K	J 1/16W
R722			RK73GB1J475J	CHIP R	4.7M	J 1/16W
R723,724			RK73GB1J394J	CHIP R	390K	J 1/16W
R726			RK73GB1J562J	CHIP R	5.6K	J 1/16W
R728			RK73GB1J103J	CHIP R	10K	J 1/16W
R730			RK73GB1J562J	CHIP R	5.6K	J 1/16W
R731,732			RK73GB1J222J	CHIP R	2.2K	J 1/16W
R733,734			RK73GB1J102J	CHIP R	1.0K	J 1/16W
R735,736			RK73GB1J224J	CHIP R	220K	J 1/16W
R744			RK73GB1J152J	CHIP R	1.5K	J 1/16W
R745			RK73GB1J473J	CHIP R	47K	J 1/16W
R801,802			RK73GB1J271J	CHIP R	270	J 1/16W
R803,804			RK73GB1J104J	CHIP R	100K	J 1/16W
R805			RK73GB1J100J	CHIP R	10	J 1/16W
R806			RK73GB1J112J	CHIP R	1.1K	J 1/16W
R807			RK73GB1J122J	CHIP R	1.2K	J 1/16W
R808			RK73GB1J112J	CHIP R	1.1K	J 1/16W
R809,810			RK73GB1J222J	CHIP R	2.2K	J 1/16W
R811			RK73GB1J332J	CHIP R	3.3K	J 1/16W
R813			RK73GB1J112J	CHIP R	1.1K	J 1/16W
R814			RK73GB1J122J	CHIP R	1.2K	J 1/16W
R815			RK73GB1J112J	CHIP R	1.1K	J 1/16W
R816,817			RK73GB1J222J	CHIP R	2.2K	J 1/16W
R818			RK73GB1J332J	CHIP R	3.3K	J 1/16W
R819			RK73GB1J103J	CHIP R	10K	J 1/16W

L : Scandinavia K : USA P : Canada R : Mexico C : China I : Malaysia
 Y : PX(Far East,Hawaii) T : England E : Europe G : Germany V : China(Shanghai)
 Y : AAFES(Europe) X : Australia Q : Russia H : Korea M : Other Areas Δ indicates safety critical components.

PARTS LIST

* New Parts
 Parts without **Parts No.** are not supplied.
 Les articles non mentionnés dans le **Parts No.** ne sont pas fournis.
 Teile ohne **Parts No.** werden nicht geliefert.

11

Ref. No	Add-ress	New Parts	Parts No.	Description	Desti-nation	Re-marks
R820			RK73GB1J473J	CHIP R 47K J 1/16W		
R821			RK73GB1J103J	CHIP R 10K J 1/16W		
R822			RK73GB1J473J	CHIP R 47K J 1/16W		
R823			RK73GB1J103J	CHIP R 10K J 1/16W		
R824			RK73GB1J473J	CHIP R 47K J 1/16W		
R825			RK73GB1J103J	CHIP R 10K J 1/16W		
R826			RK73GB1J473J	CHIP R 47K J 1/16W		
R829,830			RK73GB1J472J	CHIP R 4.7K J 1/16W		
R851,852			RK73GB1J103J	CHIP R 10K J 1/16W		
VR101			R12-0037-05	SEMI-FIXED RES 012-19103-100		
VR801		*	T99-0676-08	ROTARY ENCODER 020-81212-151		
W101-103			RK73GB1J000J	CHIP R 0 J 1/16W		
W201-205			RK73GB1J000J	CHIP R 0 J 1/16W		
W301,302			RK73GB1J000J	CHIP R 0 J 1/16W		
W404,405			RK73GB1J000J	CHIP R 0 J 1/16W		
W701			RK73GB1J000J	CHIP R 0 J 1/16W		
RL601			S74-0093-08	RELAY SDT-S-10 065-00105-001		
SW701		*	S62-0116-08	SLIDE SWITCH S 020-11208-104		
SW801-807			S70-0096-08	TACT SWITCH EV 020-31100-164		
SW809			S70-0096-08	TACT SWITCH EV 020-31100-164		
SW813-815			S70-0096-08	TACT SWITCH EV 020-31100-164		
BD601,602			KBL402	BRIDGE RECTIFIER		
D101,102			1SS133	SWITCHING DIODE		
D103			MTZJ5.6B	ZENER DIODE		
D104			1SS133	SWITCHING DIODE		
D201			1SS355	SW. DIODES		
D301,302			1SS355	SW. DIODES		
D401,402			1SS133	SWITCHING DIODE		
D404			1SS133	SWITCHING DIODE		
D406			1SS133	SWITCHING DIODE		
D408,409			1SS133	SWITCHING DIODE		
D410,411			1SS355	SW. DIODES		
D412			MTZJ2.7B	ZENER DIODE		
D601-604			1SR139-400	SWITCHING DIODE		
D605			MTZJ5.6B	ZENER DIODE		
D606			MTZJ6.2B	ZENER DIODE		
D607			MTZJ13B	ZENER DIODE		
D608			MTZJ16(B)	ZENER DIODE		
D609			1SR139-400	SWITCHING DIODE		
D612			MTZJ6.2B	ZENER DIODE		
D613			1SR139-400	SWITCHING DIODE		
D615-623			1SS133	SWITCHING DIODE		
D627,628			1SS133	SWITCHING DIODE		
D629			MTZJ5.1B	ZENER DIODE		
D801		*	B30-2558-08	BI-COLOR LED 019-10000-001		
FL801		*	B30-2647-08	FLUORESCENT 049-14063-001		
IC101		*	LA1844M	IC LA1844M		
IC102		*	LC72131MD-TFB	IC LC72131MD-T	NESE	
IC103			BU1923F	IC(RDS DEMODULATOR)		
IC201			AN8399SA-E1	IC(3BEAM DIGITAL SERVO HEAD AM		
IC202			MN6627482WB	IC(SIGNAL PROCESSING IC FOR CD		
IC203			AN4801SB-E1	IC(CD/MD DRIVER)		
IC301			LC75342M	IC LC75342M		
IC401			MN101C51FGC	IC MN101C51F		
IC402		*	BD4740G	IC BD4740G		

L : Scandinavia K : USA P : Canada R : Mexico C : China I : Malaysia
 Y : PX(Far East,Hawaii) T : England E : Europe G : Germany V : China(Shanghai)
 Y : AAFES(Europe) X : Australia Q : Russia H : Korea M : Other Areas Δ indicates safety critical components .

* New Parts
 Parts without **Parts No.** are not supplied.
 Les articles non mentionnés dans le **Parts No.** ne sont pas fournis.
 Teile ohne **Parts No.** werden nicht geliefert.

12

Ref. No	Add-ress	New Parts	Parts No.	Description	Desti-nation	Re-marks
IC404			BR24C02F-W	IC(E2PROM)F-W		
IC601,602		*	TDA2030A	IC TDA2030A 002-02030-070		
IC601,602			TDA2040V	IC(20W POWER AMP)		
IC603		*	BA17809T	IC BA17809T		
IC604			BA17805T	IC(VOLTAGE REGULATOR/ +5V)		
IC605			TA78057S	IC(VOLTAGE REGULATOR/+5.75V)		
IC701		*	AN7317	IC AN7317		
IC702			BA3126N	IC(HEAD SW)		
IC801			MN12510F	IC MN12510F		
IC802		*	W02-2981-08	INFRARED REMOT 061-01271-001		
Q101			2SC930E	TRANSISTOR		
Q102			2SA1037K	CHIP TRANSISTOR		
Q103			2SC2412K	CHIP TRANSISTOR		
Q104			DTC124EUA	CHIP TRANSISTOR		
Q105			2SC2412K	CHIP TRANSISTOR	E2E3	
Q105			2SC2412K	CHIP TRANSISTOR	NESEH	
Q105			2SC2412K	CHIP TRANSISTOR	NTST	
Q106			2SA1037K	CHIP TRANSISTOR	E2E3	
Q106			2SA1037K	CHIP TRANSISTOR	NESEH	
Q106			2SA1037K	CHIP TRANSISTOR	NTST	
Q201			2SA1037K	CHIP TRANSISTOR		
Q205			DTA124EUA	CHIP TRANSISTOR		
Q401			2SC2412K	CHIP TRANSISTOR		
Q402			2SA1037K	CHIP TRANSISTOR		
Q403			2SB1205S	TRANSISTOR		
Q404			2SA1036K	CHIP TRANSISTOR		
Q405,406			DTC124EUA	CHIP TRANSISTOR		
Q601,602			2SD2114K	CHIP TRANSISTOR		
Q603			2SD2061E	TRANSISTOR		
Q604			2SA1036K	CHIP TRANSISTOR		
Q605			2SA1037K	CHIP TRANSISTOR		
Q606			2SA1036K	CHIP TRANSISTOR		
Q607			DTC124EUA	CHIP TRANSISTOR		
Q608			2SC2412K	CHIP TRANSISTOR		
Q609			2SA1036K	CHIP TRANSISTOR		
Q612			DTC124EUA	CHIP TRANSISTOR		
Q613			DTA124EUA	CHIP TRANSISTOR		
Q621,622			2SC2412K	CHIP TRANSISTOR		
Q623			2SA1037K	CHIP TRANSISTOR		
Q703			2SC2412K	CHIP TRANSISTOR		
Q704			2SA1037K	CHIP TRANSISTOR		
Q705-707			2SC2412K	CHIP TRANSISTOR		
Q708			2SA1036K	CHIP TRANSISTOR		
Q709			DTC124EUA	CHIP TRANSISTOR		
Q801,802			2SC2412K	CHIP TRANSISTOR		
Q803-806			2SA1037K	CHIP TRANSISTOR		
VC101			SVC342L	TUNING DIODE		
U101		*	W02-2982-08	FM AUDIO TUNER 061-16104-001	SKSX	
U101		*	W02-2983-08	FM AUDIO TUNER 061-17104-001	E2E3	
U101		*	W02-2983-08	FM AUDIO TUNER 061-17104-001	NESEH	

L : Scandinavia K : USA P : Canada R : Mexico C : China I : Malaysia
 Y : PX(Far East,Hawaii) T : England E : Europe G : Germany V : China(Shanghai)
 Y : AAFES(Europe) X : Australia Q : Russia H : Korea M : Other Areas Δ indicates safety critical components .

PARTS LIST

RXD-M35

RXD-M35

PARTS LIST

HOW TO READ THE PARTS LIST

ABBREVIATION OF MODEL AND MASS PRODUCTION'S DESTINATIONS

<i>MODEL</i>	<i>ABB.</i>	<i>Australia</i>	<i>Canada</i>	<i>China</i>	<i>England</i>	<i>Europe</i>	<i>Germany</i>	<i>Korea</i>	<i>Malaysia</i>
HM335-N		-	-	-	-	-	-	-	-
HM335-S		SX	-	-	-	-	-	-	-
RXD-M35E-N		-	-	-	-	E3	-	-	-
RXD-M35E-S		-	-	-	-	E2	-	-	-
RXD-M35-N		-	-	-	NT	NE	-	H	-
RXD-M35-S		-	-	-	ST	SE	-	-	-
<i>MODEL</i>	<i>ABB.</i>	<i>Mexico</i>	<i>PX/AAFES</i>	<i>Russia</i>	<i>Scandinavia</i>	<i>Shanghai</i>	<i>USA</i>	<i>Other area</i>	
HM335-N		-	-	-	-	-	-	-	
HM335-S		-	-	-	-	-	SK	-	
RXD-M35E-N		-	-	-	-	-	-	-	
RXD-M35E-S		-	-	-	-	-	-	-	
RXD-M35-N		-	-	-	-	-	-	-	
RXD-M35-S		-	-	-	-	-	-	-	

RXD-M35

SPECIFICATIONS

Main unit

[Amplifier section]

(For U.S.A. and Canada)

Rated output power during STEREO operation (FTC)

13 watts per channel minimum RMS, both channels driven, at 6 Ω from 90 Hz to 15 kHz with no more than 10 % total harmonic distortion.

(For U.K. and Europe)

Effective output power during STEREO operation

(1 kHz, 10% T.H.D., at 6 Ω) 15 W + 15 W

Rated output power during STEREO operation

(1 kHz, 0.7% T.H.D., at 6 Ω) 11 W + 11 W

(For other countries)

Rated output power during STEREO operation

(1 kHz, 10% T.H.D., at 6 Ω) 15 W + 15 W

[Tuner section]

FM tuner section

Tuning frequency range 87.5 MHz ~ 108 MHz

MW (AM) tuner section

(For U.S.A. and Canada)

Tuning frequency range 530 kHz ~ 1,700 kHz

(For U.K. and Europe)

Tuning frequency range 531 kHz ~ 1,602 kHz

(For Australia)

Tuning frequency range 531 kHz ~ 1,602 kHz

(For other countries)

Tuning frequency range

9 kHz step 531 kHz ~ 1,602 kHz

10 kHz step 530 kHz ~ 1,610 kHz

[CD player section]

Laser Semiconductor laser

Over sampling 8 fs (352.8 Hz)

Laser wave length 760 - 800 nm

Laser power class Class 3A (IEC)

D/A Conversion 1 Bit

[Cassette deck section]

Track 4-track, 2-channel stereo

Recording system AC bias system
(Frequency: 105 kHz)

Heads

Playback/ recording head 1

Erasing head 1

Wow and flutter 0.2 % (W.R.M.S.)

Fast winding time Approx. 100 seconds
(C-60 tape)

[General]

Power consumption 45 W

Dimensions W : 150 mm (5-7/8")

H : 223 mm (8-3/4")

D : 265 mm (10-7/16")

Weight (net) 3.75 kg (8.3 lb)

Speakers (LS-M35)

Enclosure Bass-reflex type

Speaker configuration

Woofer 100 mm, cone type

Tweeter 20 mm, piezo type

Impedance 6 Ω

Maximum input power 20 W

Dimensions W : 130 mm (5-1/8")

H : 220 mm (8-11/16")

D : 214 mm (8-7/16")

Weight (net) 1.65 kg (3.64 lb) (1 piece)



KENWOOD follows a policy of continuous advancements in development. For this reason specifications may be changed without notice.

- Sufficient performance may not be exhibited at extremely cold locations (where water freezes).

Note:

Component and circuit are subject to modification to insure best operation under differing local conditions. This manual is based on Europe (E) standard, and provides information on regional circuit modification through use of alternate schematic diagrams, and information on regional component variations through use of parts list.

KENWOOD CORPORATION

2967-3, Ishikawa-machi, Hachioji-shi, Tokyo, 192-8525 Japan

KENWOOD U.S.A. CORPORATION

P.O. BOX 22745, 2201 East Dominguez St., Long Beach, CA 90801-5745, U.S.A.

KENWOOD ELECTRONICS CANADA INC.

6070 Kestrel Road, Mississauga, Ontario, Canada L5T 1S8

KENWOOD ELECTRONICS LATIN AMERICA S.A.

P.O. BOX 55-2791, Piso 6 plaza Chase, Cl. 47 y Aquilino de la Guardia Panama, Republic de Panama

KENWOOD ELECTRONICS BRASIL LTDA.

Alameda Ministro Rocha Azevedo No. 456, Edifício Jaú, 10o Andar, Cerqueira César, Cep 0140-001, São Paulo-SP-Brasil

KENWOOD ELECTRONICS U.K. LIMITED

KENWOOD House, Dwight Road, Watford, Herts., WD1 8EB., United Kingdom

KENWOOD ELECTRONICS BELGIUM N.V.

Leuvensesteenweg 248 J, 1800 Vilvoorde, Belgium

KENWOOD ELECTRONICS DEUTSCHLAND GMBH

Rembrücker Str. 15, 63150 Heusenstamm, Germany

KENWOOD ELECTRONICS FRANCE S.A.

13 Boulevard Ney, 75018 Paris, France

KENWOOD ELECTRONICS ITALIA S.p.A.

Via G. Sirtori, 7/9 20129, Milano, Italy

KENWOOD IBÉRICA S.A.

Bolivia, 239-08020 Barcelona, Spain

KENWOOD ELECTRONICS AUSTRALIA PTY. LTD.

(A.C.N. 001 499 074)
16 Giffnock Avenue, North Ryde, N.S.W. 2113, Australia

KENWOOD ELECTRONICS (HONG KONG) LTD.

Unit 3712-3724, Level 37, Tower 1, Metroplaza, 223 Hing Fong Road, Kwai Fong N.T., Hong Kong

KENWOOD ELECTRONICS GULF FZE

P.O. Box 61318, Jebel Ali, Dubai, U.A.E.

KENWOOD ELECTRONICS SINGAPORE PTE LTD.

No. 1 Genting Lane #02-02, KENWOOD Building, Singapore, 349544

KENWOOD ELECTRONICS (MALAYSIA) SDN BHD.

#4.01 Level 4, Wisma Academy Lot 4A, Jalan 19/1 46300 Petaling Jaya Selangor Darul Ehsan Malaysia

KENWOOD ELECTRONICS (THAILAND) CO., LTD.

2019 New Pechburi Road, Bangkapi, Huaykwang, Bangkok, 10320 Thailand