

# STEREO POWER AMPLIFIER M-A100/A300 SERVICE MANUAL

## KENWOOD

## M-A100/A300

### CONTENTS / ACCESSORIES

© 1997-6/B51-5321-00 (K/K) 3668

<b>Contents</b>	
CONTENTS / ACCESSORIES .....	2
DISASSEMBLY FOR REPAIR .....	3
ADJUSTMENT .....	4
PC BOARD .....	5
SCHEMATIC DIAGRAM .....	9
EXPLODED VIEW .....	15
PARTS LIST .....	16
SPECIFICATIONS .....	21

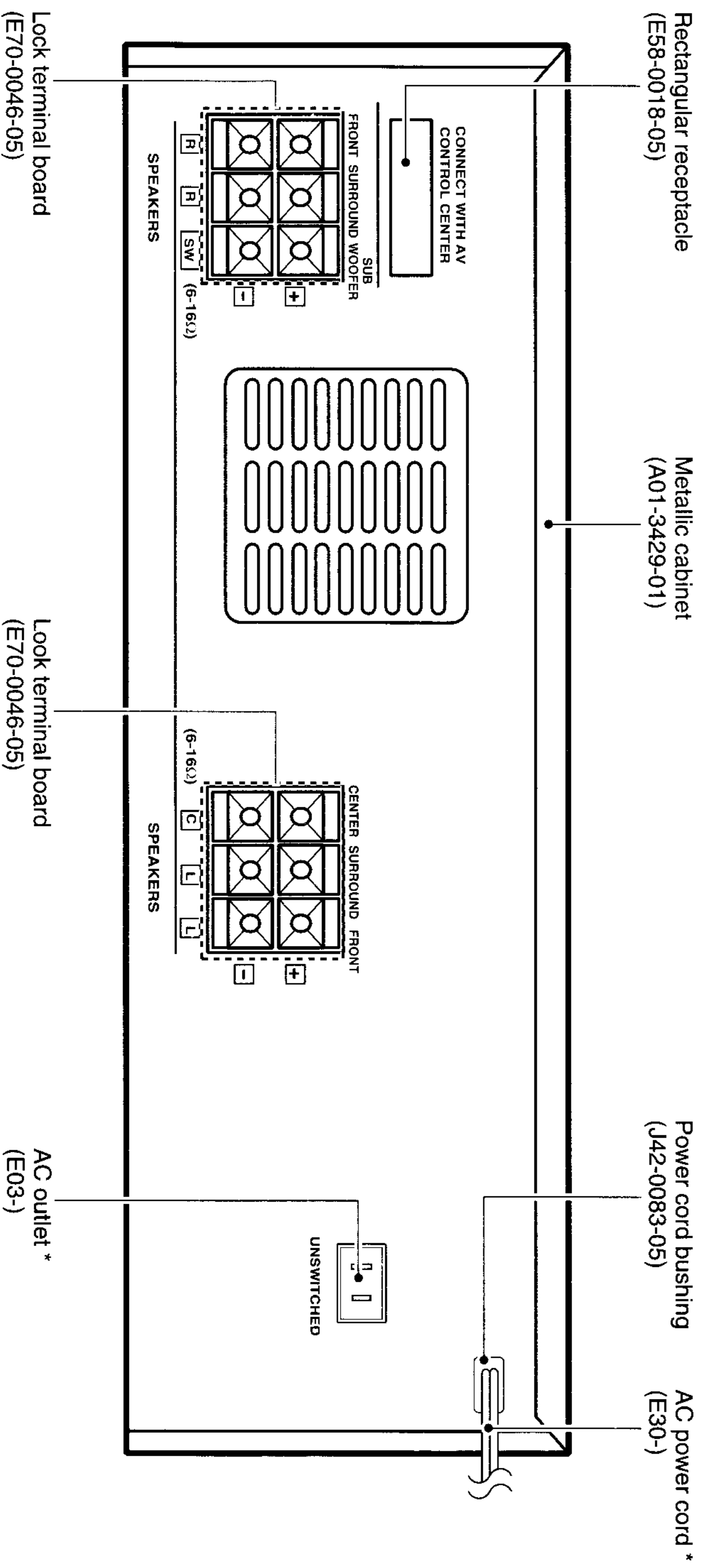
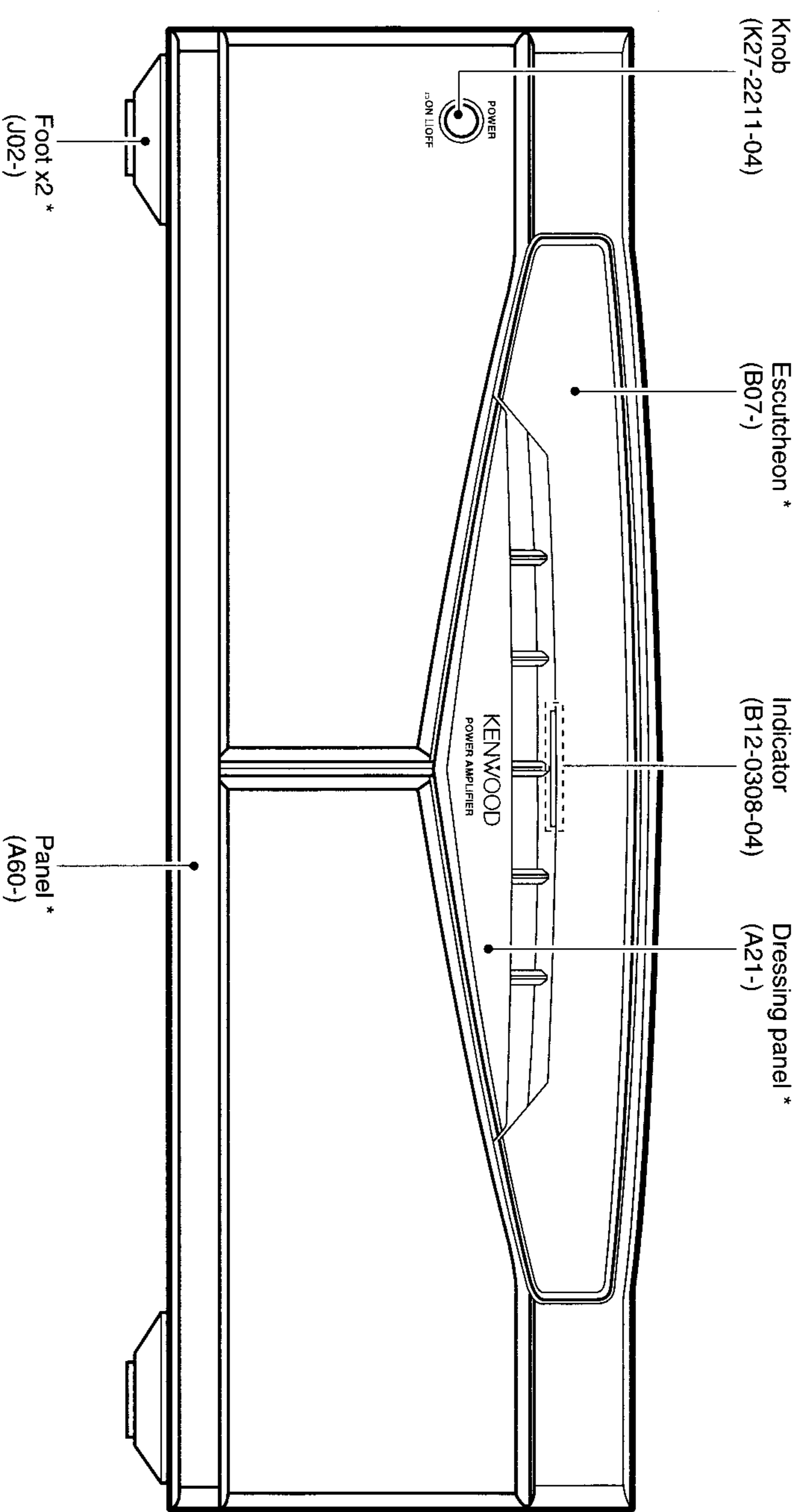

Illustration is M-A300.  
\* Refer to parts list on page 16.

How to power on unit only.  
Connect a lead wire between P3 (GRY) and fuse holder (CN3 of F2) or (CN10 of F3), then push power sw.

### Accessories

Parallel cord .....(1)  
(E30-2857-05)



AC plug adaptor .....(1)  
(E03-0115-05)

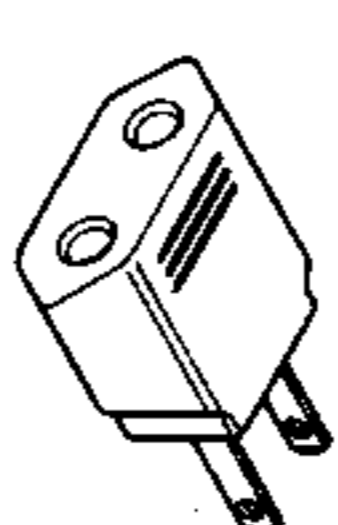

Use to adapt the plug on the power cord to the shape of the wall outlet. (Accessory only for regions where use is necessary.)

# M-A100/A300 M-A100/A300

## DISASSEMBLY FOR REPAIR

## ADJUSTMENT

1. Remove the 17 screws (1), then remove main PCB.
2. Stand the set with right side downward, then connect the GND of the PCB (X07) (A/4) and the rear panel and the chassis with 2 alligator clips (2).

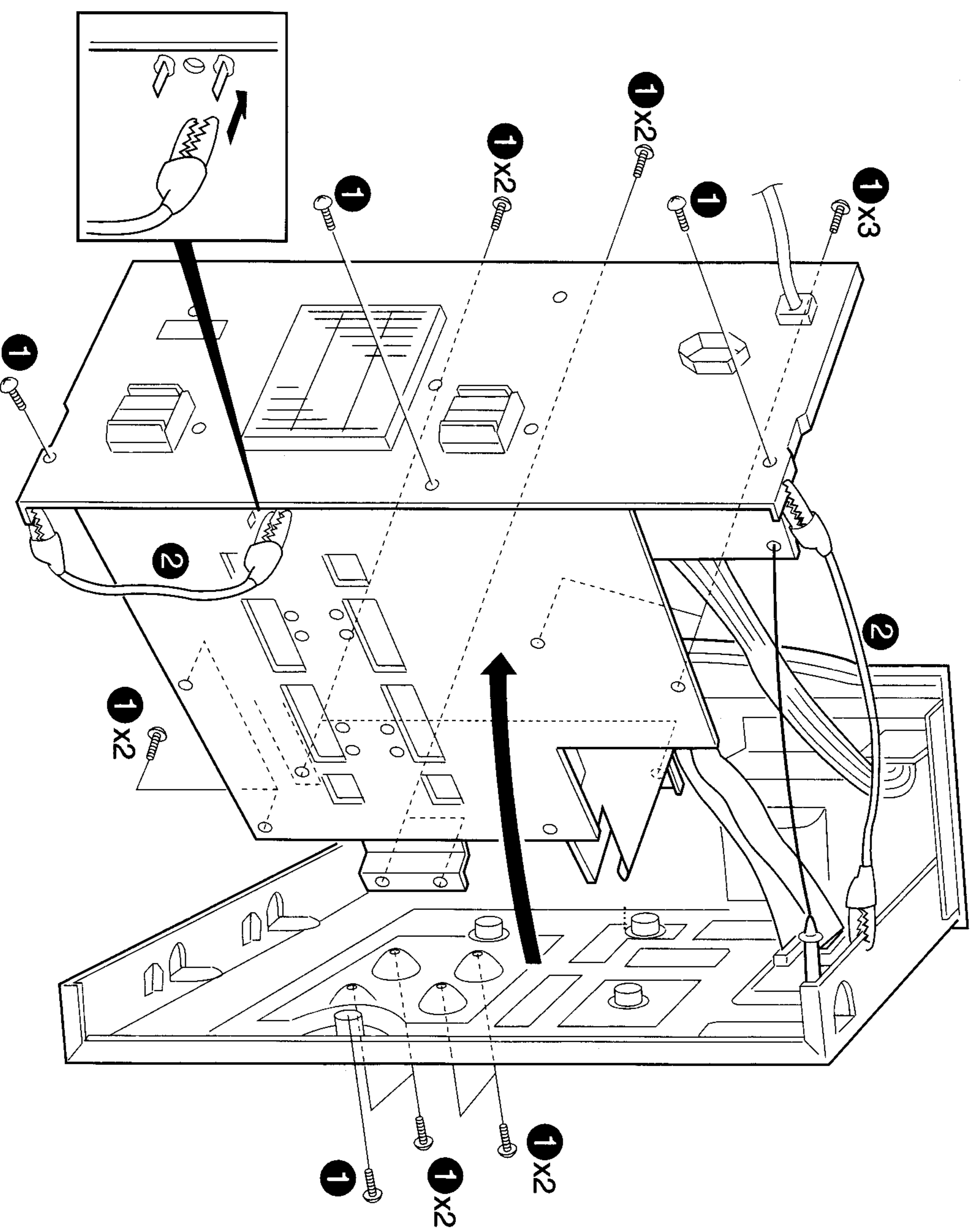

No.	ITEM	INPUT SETTINGS	OUTPUT SETTING	TUNER SETTINGS	ALIGNMENT POINTS	ALIGN FOR	FIG.
<b>AUDIO SECTION (M-A100)</b>							
<1>	*IDLE CURRENT	—	Connect a DC voltmeter across CN11(L) CN12(R) CN15(CENTER) CN16(SURROUND) (X07-)	Volume : 0	VR1(L) VR2(R) VR5(CENTER) VR6 (SURROUND) (X07-)	(L, R) 17.6mV (CENTER, SUR- ROUND) 13.2mV	
<b>AUDIO SECTION (M-A300)</b>							
<1>	*IDLE CURRENT	—	Connect a DC voltmeter across CN11(L) CN12(R) CN13(CENTER) CN14(SW) CN15(SL) CN16(SR) (X07-)	Volume : 0	VR1(L) VR2(R) VR3(CENTER) VR4(SW) VR5(SL) VR6(SR) (X07-)	(L, R) 17.6mV (CENTER, SW, SL, SR) 13.2mV	

\* Turn on the unit for 5 minutes before adjustment.

# PC BOARD(Component side view)

SPEAKERS

SURROUND

FRONT L CENTER C FRONT L SURROUND SL CENT C

(X07-2910-10) (A/4)

(X07- ) (B/4)

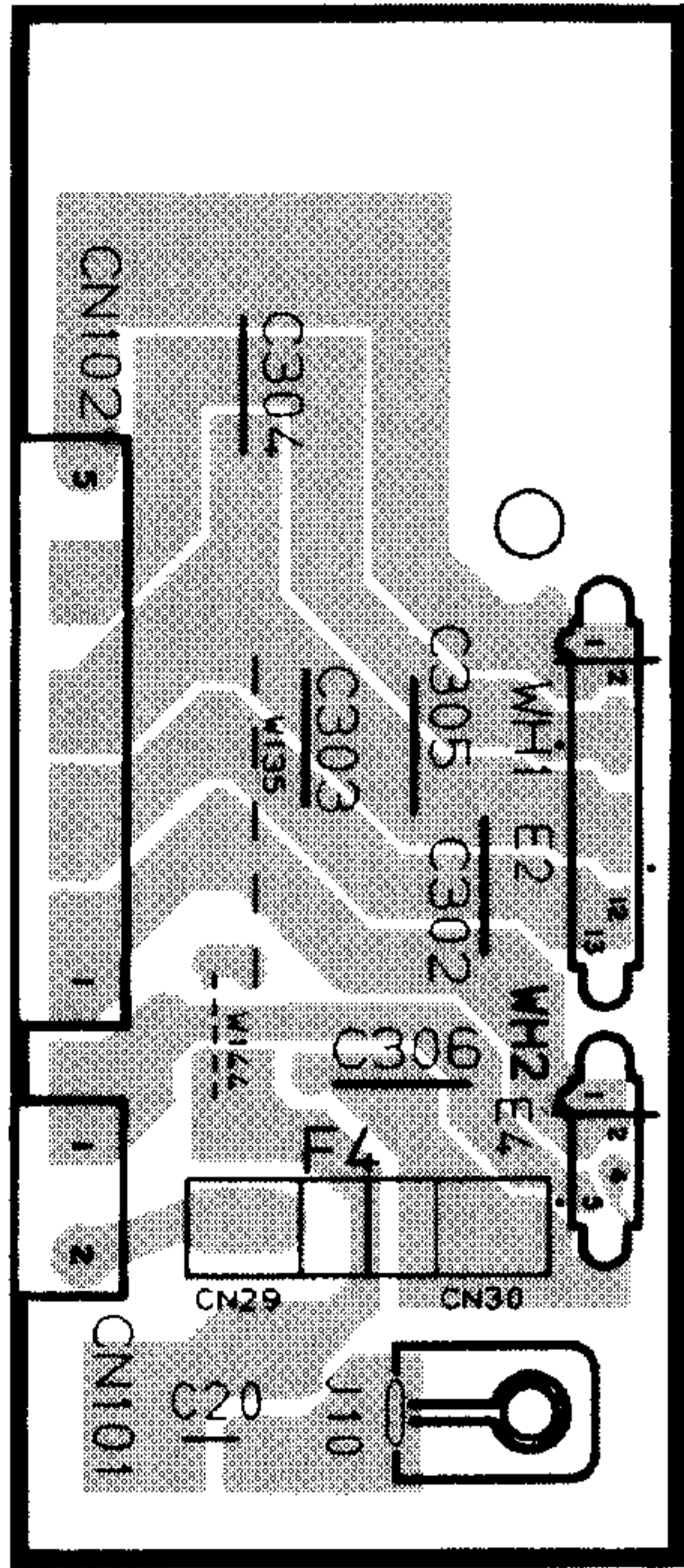

(X07- ) (D/4)

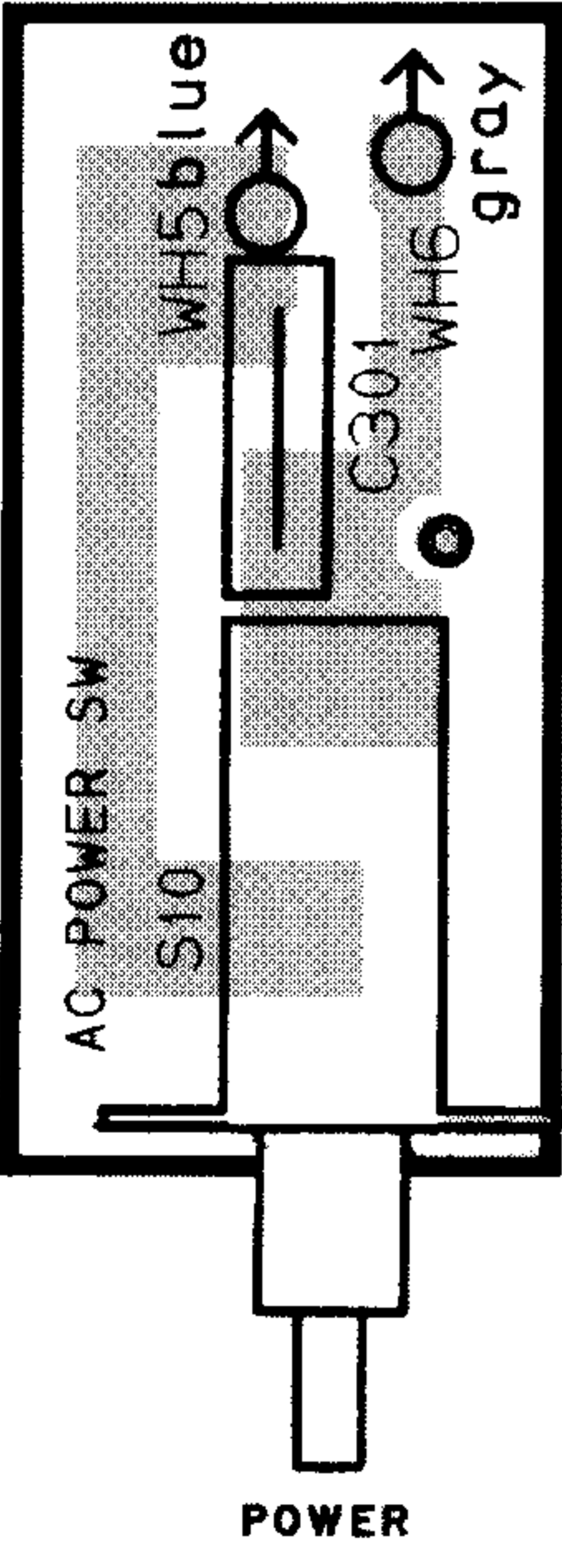

POWER

(X07- ) (C/4)

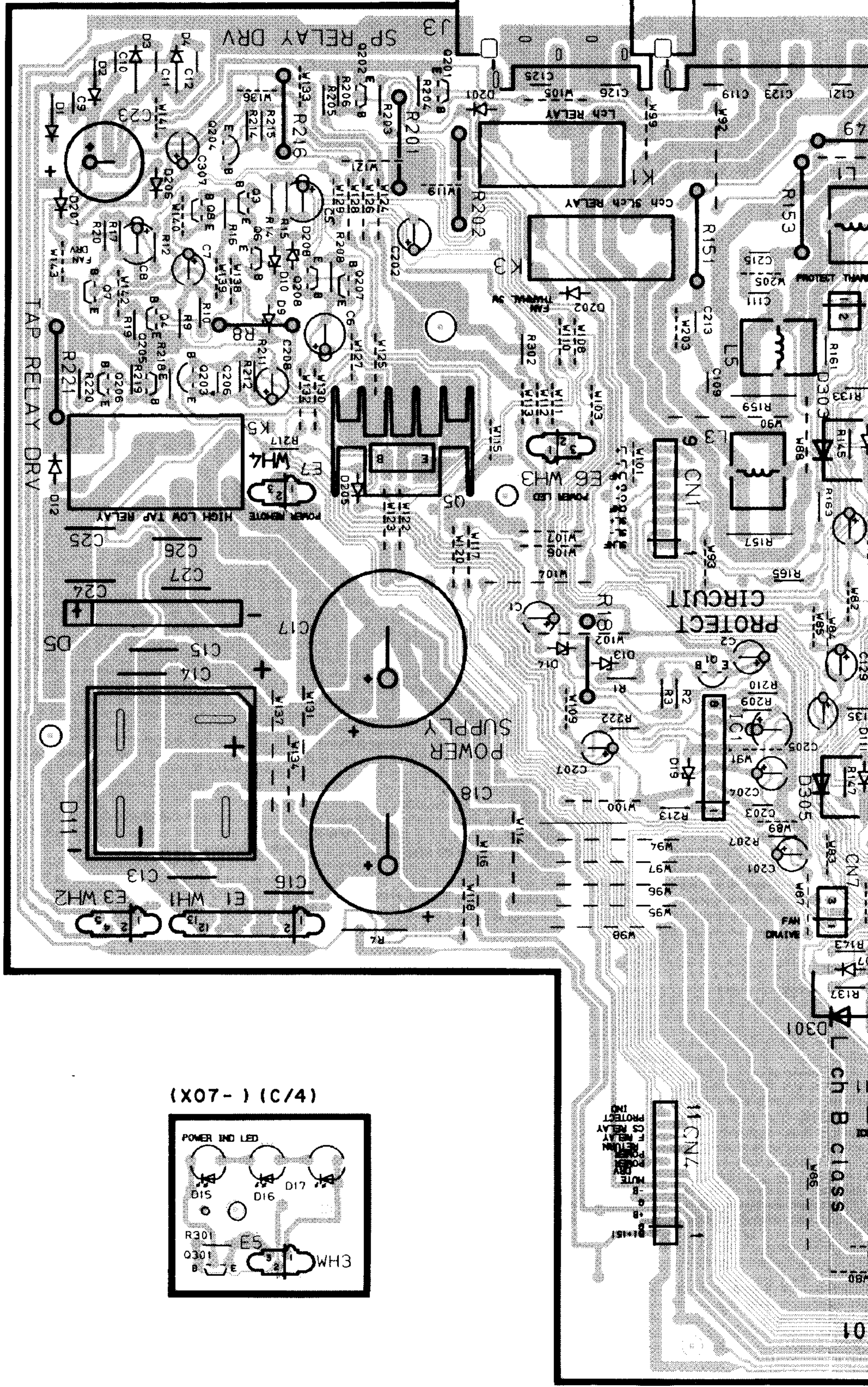
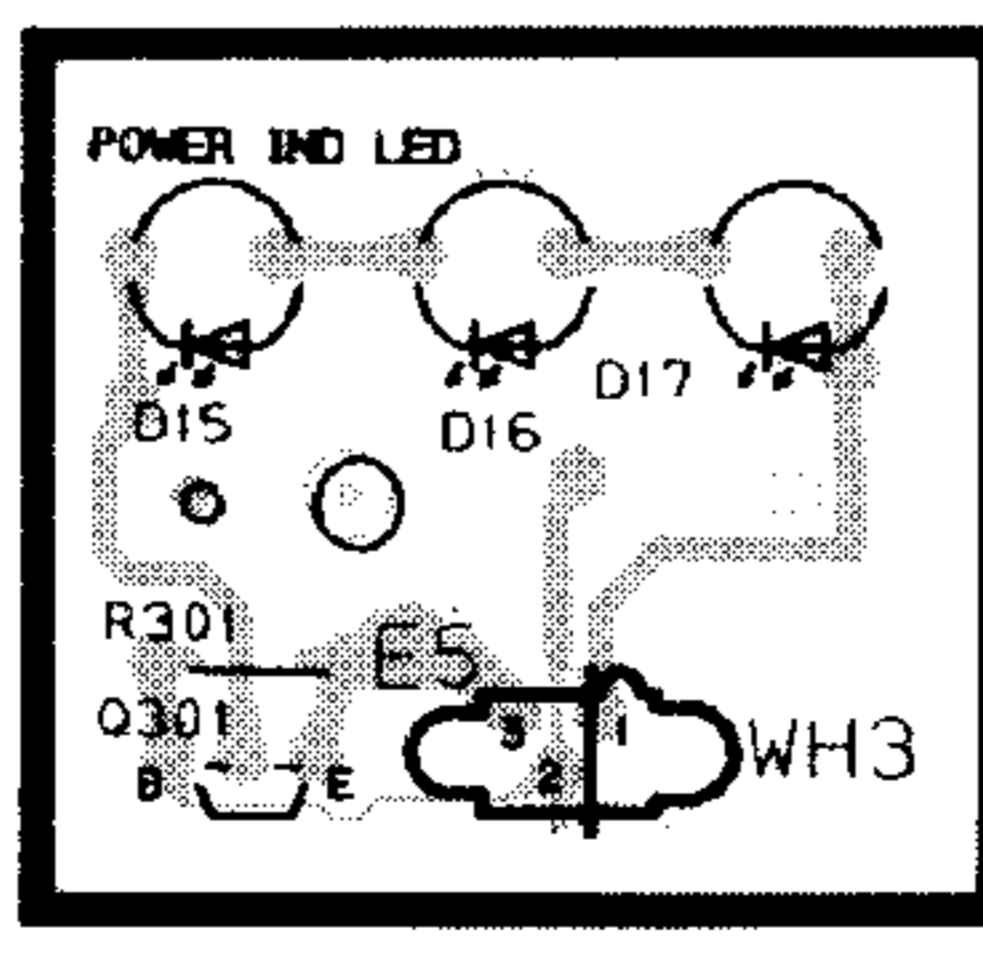

SPEAKERS

SPEAKERS

CENTER FRONT SURROUND  
C L SL C

SUB SURROUND FRONT  
WOOFER SW(SL) SR R

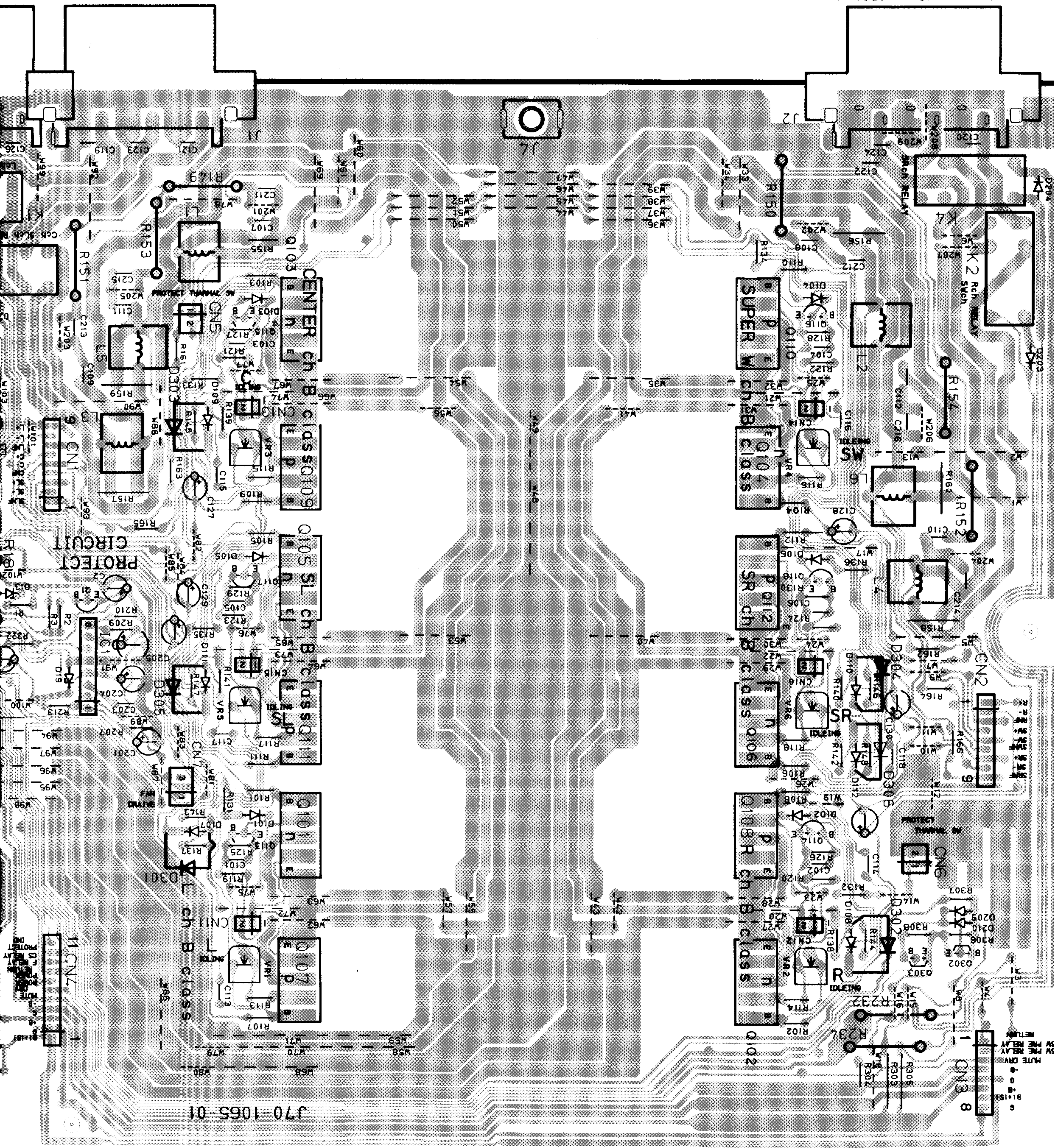

# PC BOARD(Component side view)

(XII-3740-10) (A/4)

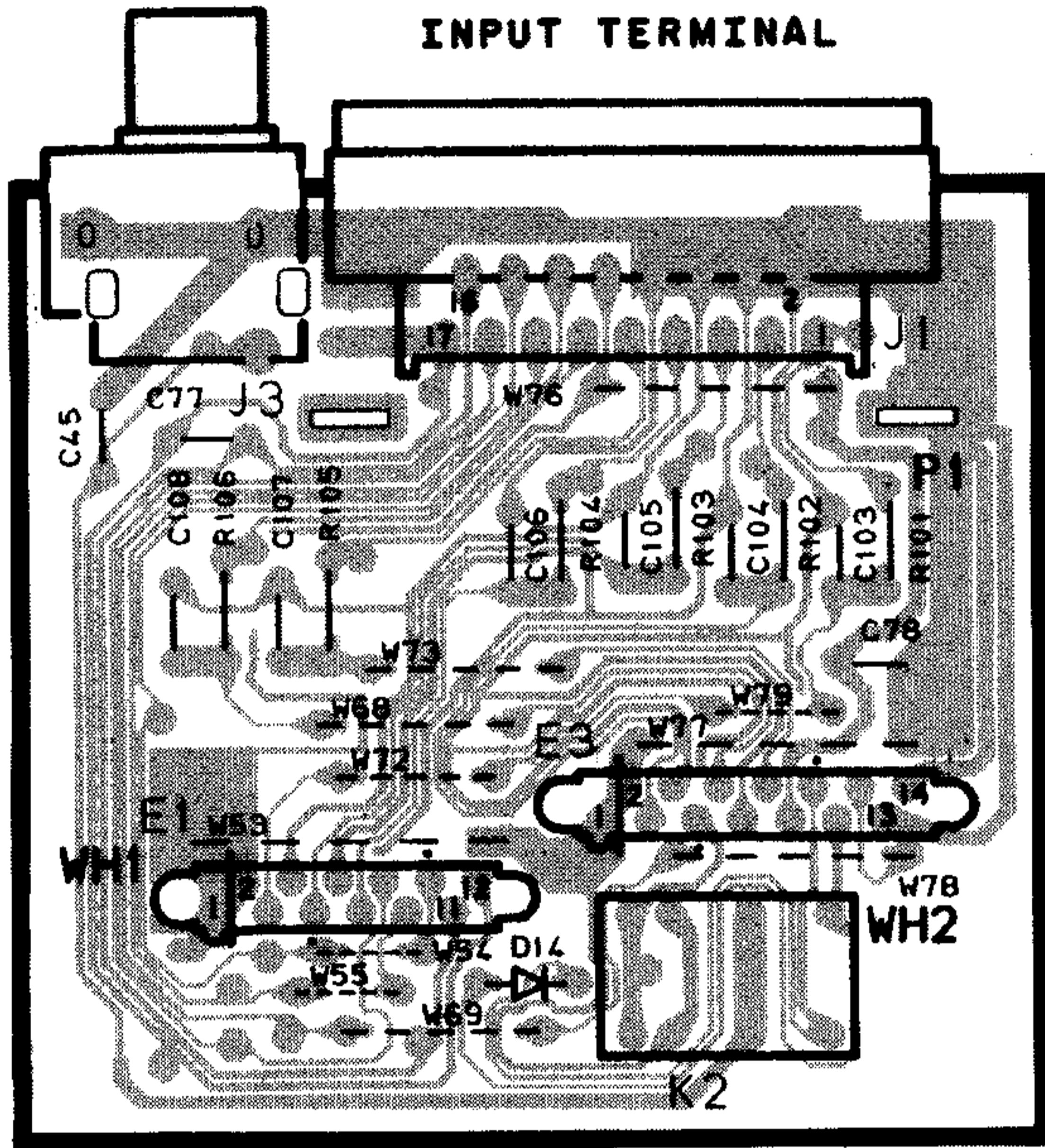

(XII- ) (C/4)

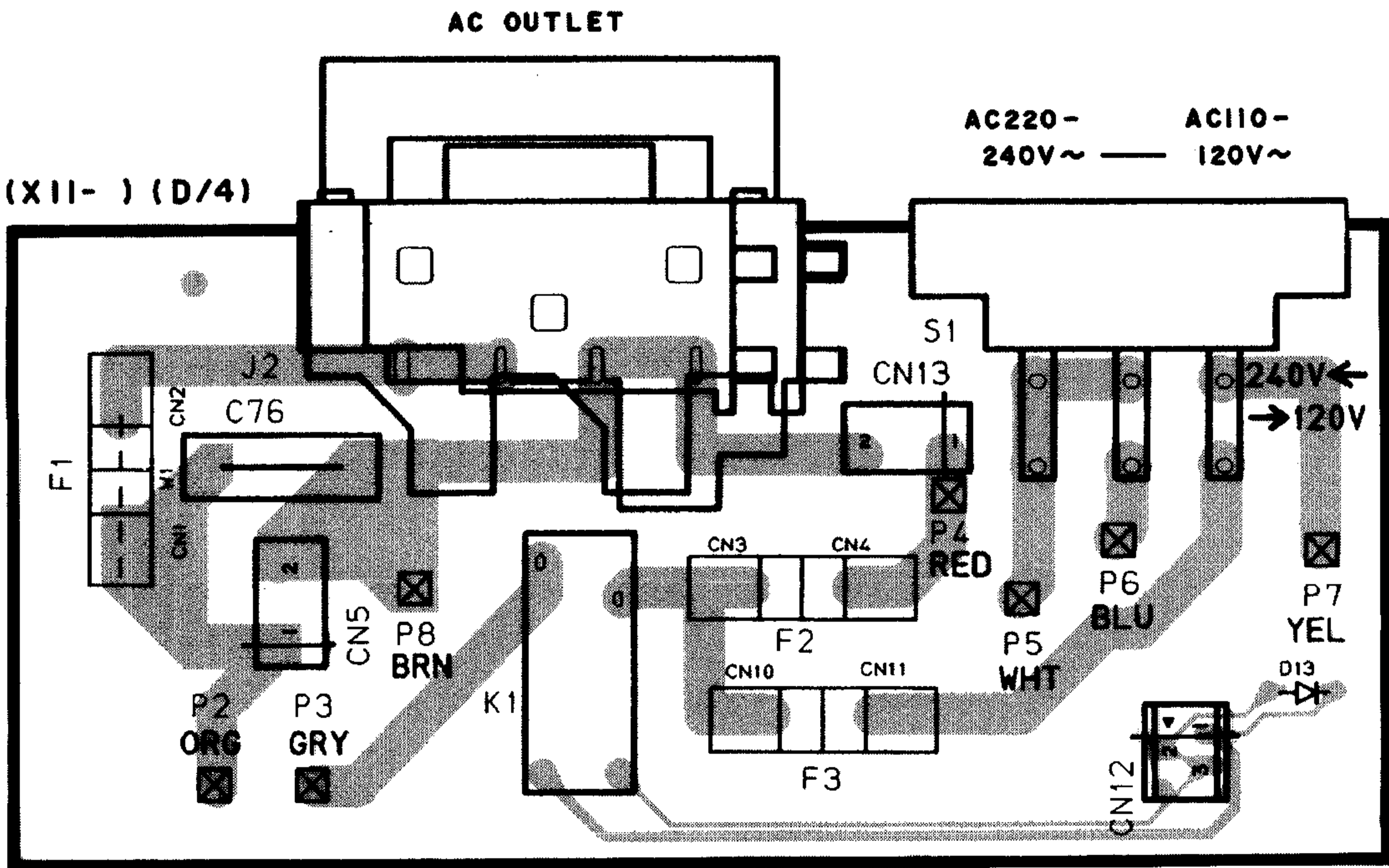

(XII- ) (D/4)

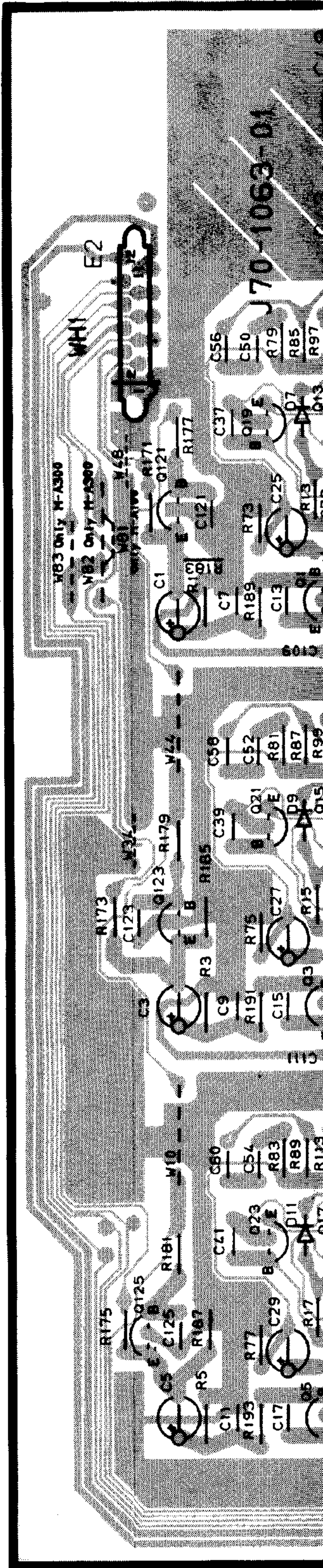

(XII-3740-10) (A/4)

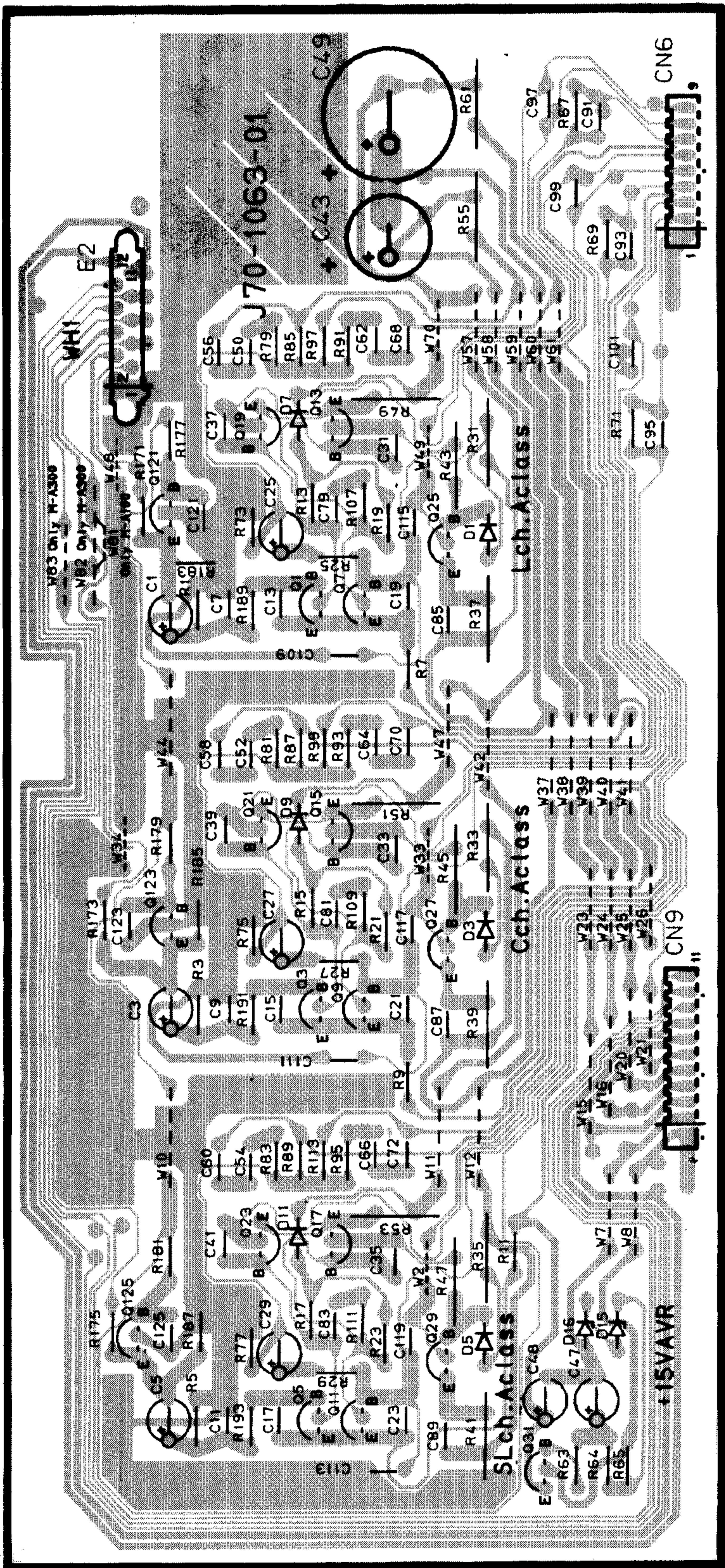

(XII- ) (B/4)

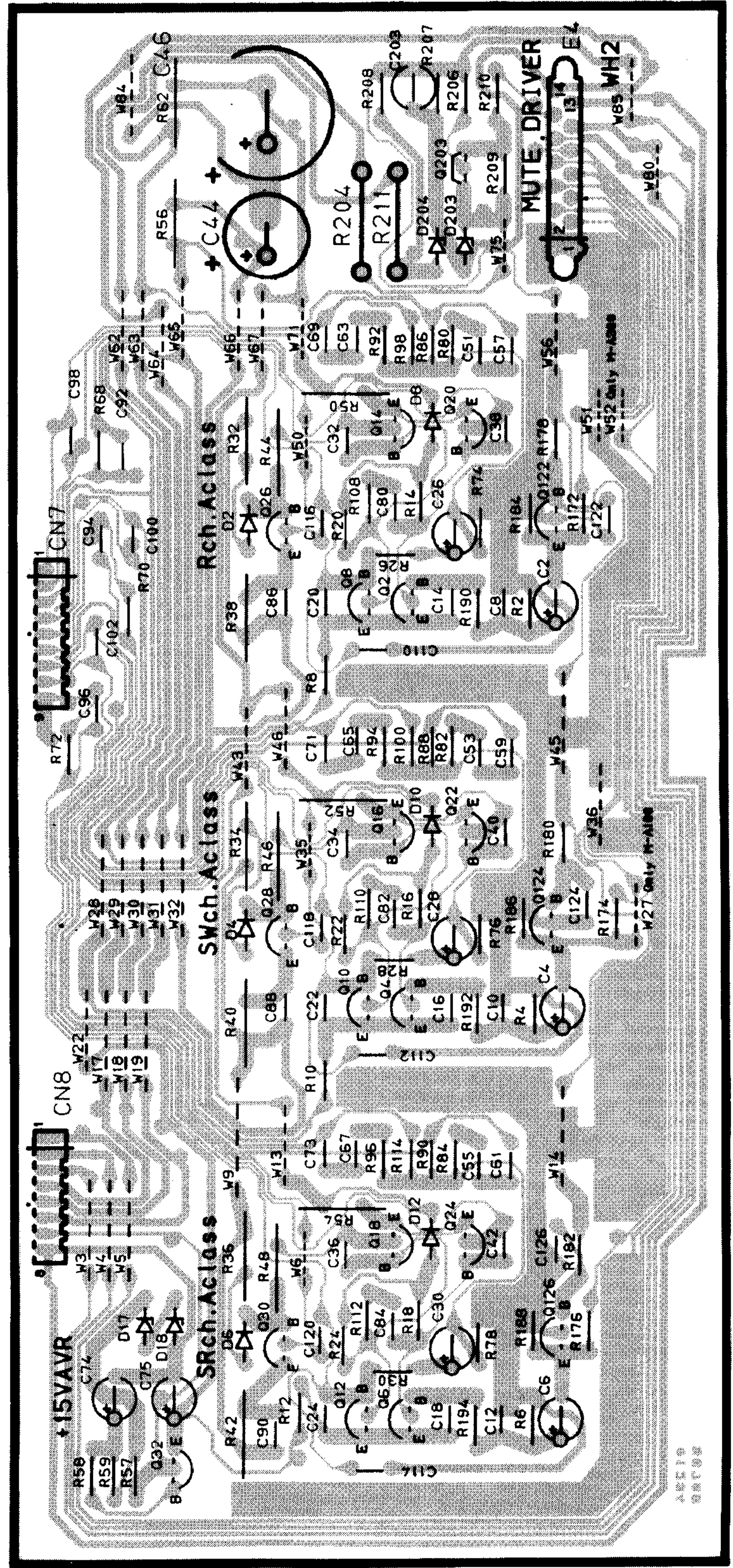



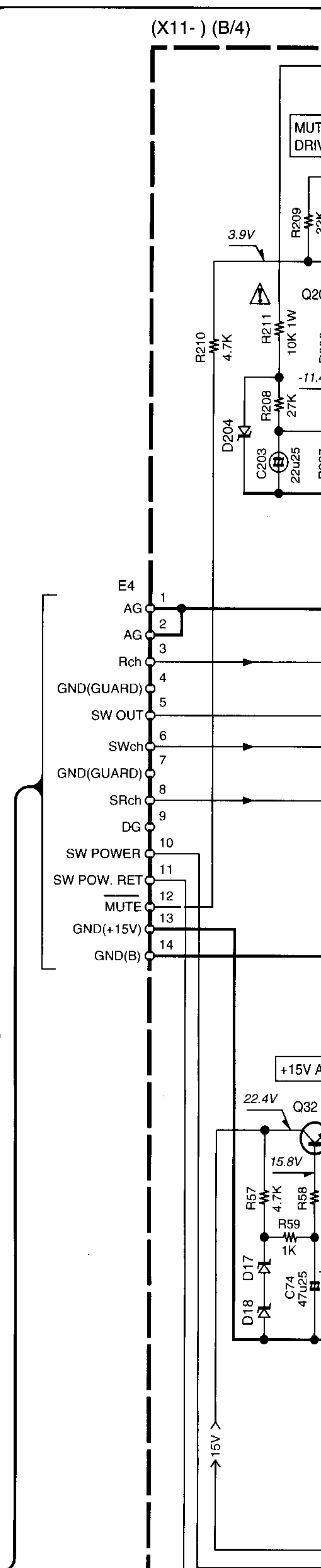
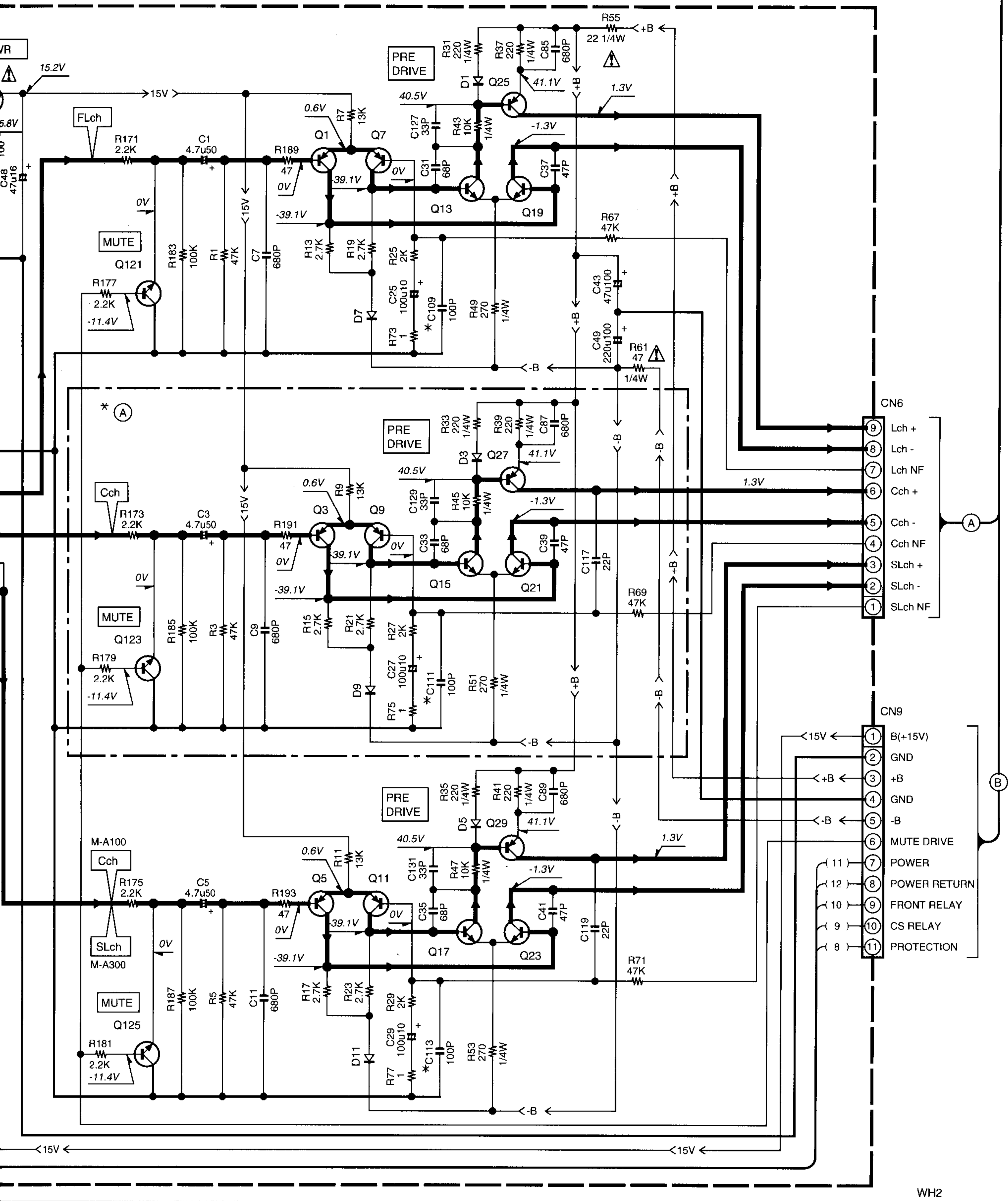

DESTINATION	COUNTRY	ABB.	UNIT No.	W27, 81	W52,82, 83	(A)	(B)	(C)	R30	C109,110, 113,114	C111, 112
U.S.A.	U.S.A.	K	X11-3740-10							NO	
CANADA	CANADA	P	X11-3742-71							YES	
EUROPE	EUROPE	E	X11-3740-51								
U.K.	U.K.	T	X11-3742-91	YES	NO	NO	YES	1.5K			NO
MARKET	MARKET	M	X11-3770-21								
ASIA	ASIA	I	X11-3773-00								
CHINA	CHINA	C	X11-3770-71								
AUSTRALIA	AUSTRALIA	X	X11-3770-71								

M-A300

DESTINATION	COUNTRY	ABB.	UNIT No.	W27, 81	W52,82, 83	(A)	(B)	(C)	R30	C109-114
U.S.A.	U.S.A.	K	X11-3740-11							NO
CANADA	CANADA	P	X11-3742-72							YES
EUROPE	EUROPE	E	X11-3740-52							
U.K.	U.K.	T	X11-3742-92	NO	YES	YES	NO	2K		
PX	PX	Y	X11-3770-22							
GENERAL MARKET	GENERAL MARKET	M	X11-3773-01							
MALAYSIA	MALAYSIA	I	X11-3770-72							
CHINA	CHINA	C	X11-3770-72							
AUSTRALIA	AUSTRALIA	X	X11-3770-72							

- D1-12,14 : 1SS131 or
- D15-18 : RD8.2ES
- MTZJ8.2
- D203 : RD3.9ES
- MTZJ3.9
- D204 : RD15ES
- MTZJ15

WH2



(X11-) (B/4)

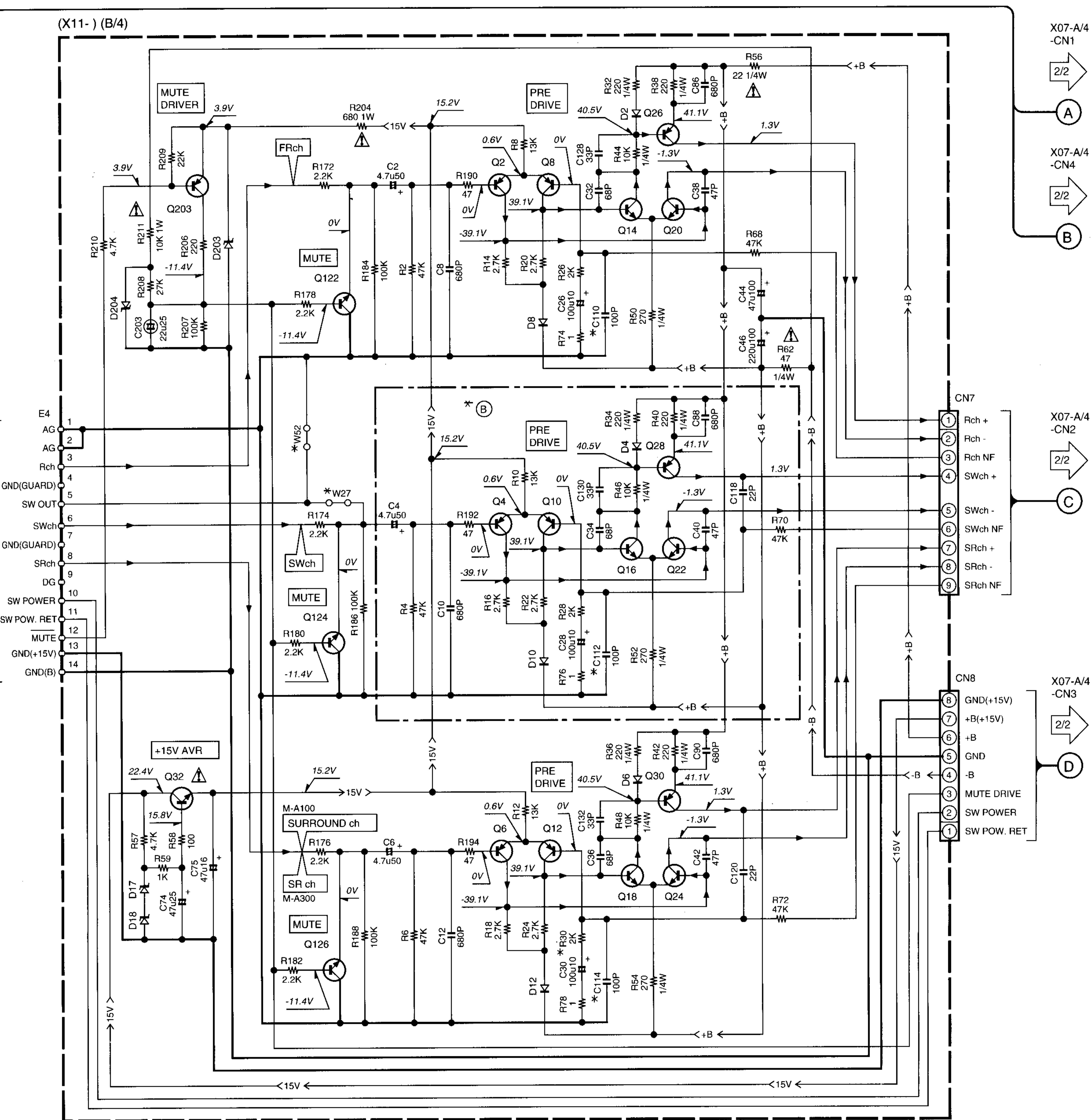

X07-A/4  
-CN1  
2/2  
A

X07-A/4  
-CN4  
2/2  
B

X07-A/4  
-CN2  
2/2  
C

X07-A/4  
-CN3  
2/2  
D

- |          |  |          |  |
|----------|--|----------|--|
| D1-12,14 | : 1SS131 or HSS104A  | Q1-12    | : 2SA992(F,E)  |
| D15-18   | : RD8.2ES(B2) or HZS8.2N(B2) or<br>MTZJ8.2(B) or UZ-8.2BSB | Q13-24   | : 2SC2631(R,S)   |
| D203     | : RD3.9ES(B2) or HZS3.9N(B2) or<br>MTZJ3.9(B) or UZ-3.9BSB | Q25-30   | : 2SA1123(R,S)   |
| D204     | : RD15ES(B2) or HZS15N(B2) or<br>MTZJ15(B) or UZ-15BSB     | Q31,32   | : 2SC3940A(R,S) or 2SD863(E,F)                                       |
|          |  | Q121-126 | : 2SC2878(B)   |
|          |  | Q203     | : 2SA1048(Y,GR) or 2SA1309A(Q,R) or<br>2SA933AS(Q,R) or 2SA1175(F,E) |

M-A100/A300(K) (1/2)

M-A100

Y08-5610-10

KENWOOD

WH4

(X07-29XX-XX) (A/4)

X11-A/4  
-CN6  
1/2  
A

X11-A/4  
-CN9  
1/2  
B

X11-B/4  
-CN7  
1/2  
C

X11-B/4  
-CN8  
1/2  
D

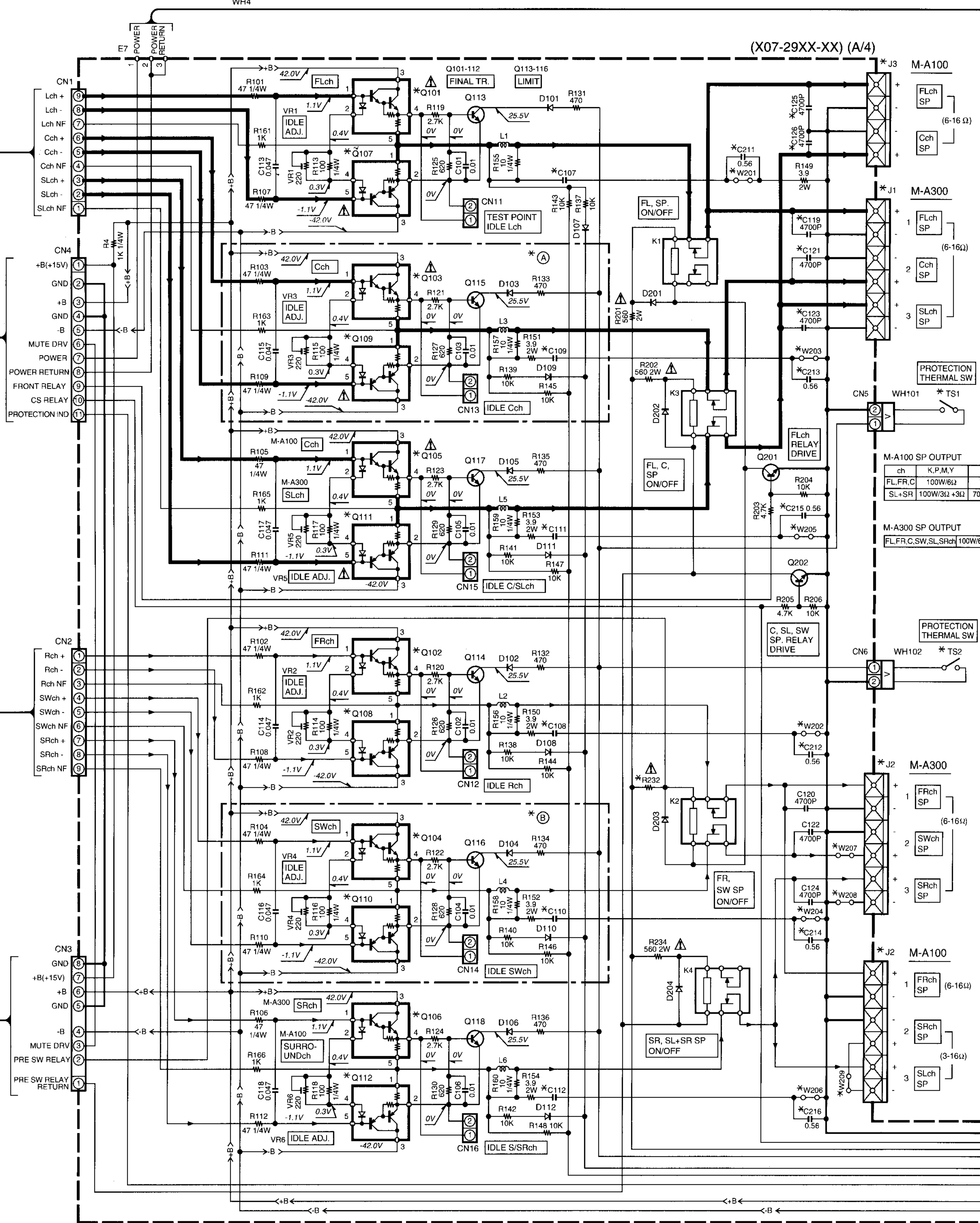

**M-A100**

- FLch SP (6-16 Ω)
- Cch SP

**M-A300**

- FLch SP (6-16Ω)
- Cch SP
- SLch SP

**M-A100 SP OUTPUT**

ch	K,P,M,Y
FL,FR,C	100W/6Ω 70
SL+SR	100W/3Ω+3Ω 70W

**M-A300 SP OUTPUT**

FL,FR,C,SW,SL,SRch	100W/6Ω
--------------------	---------

**M-A300**

- FRch SP (6-16Ω)
- SWch SP
- SRch SP

**M-A100**

- FRch SP (6-16Ω)
- SRch SP
- SLch SP (3-16Ω)

(X07-29XX-XX) (A/4)

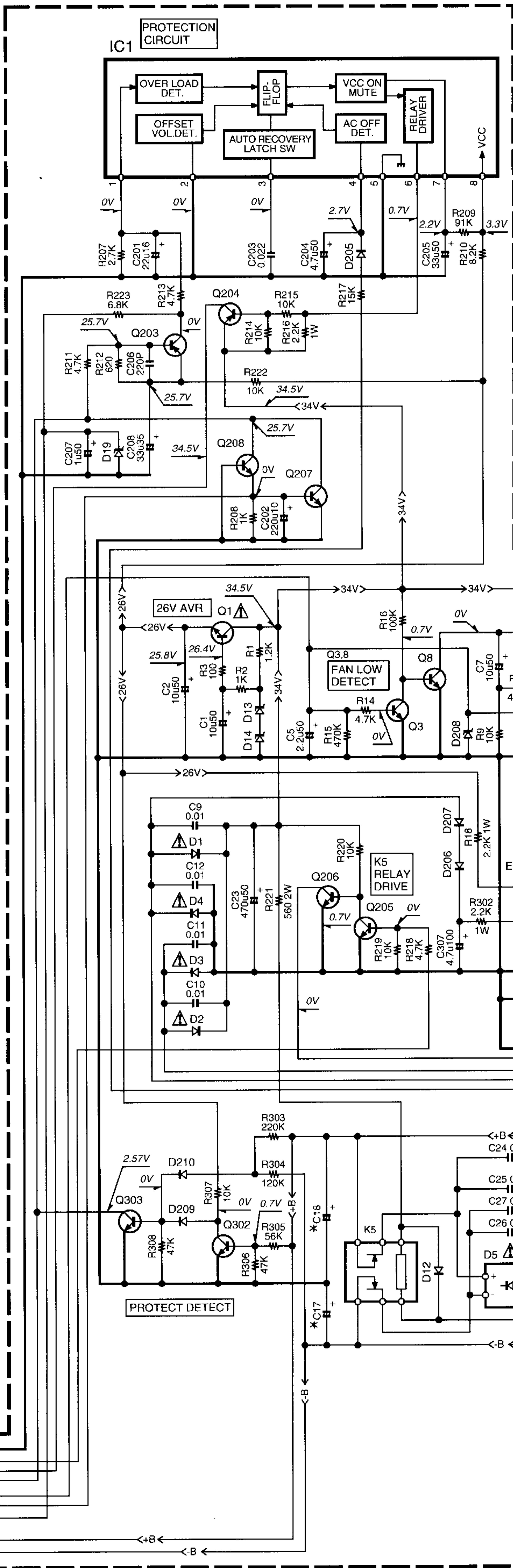
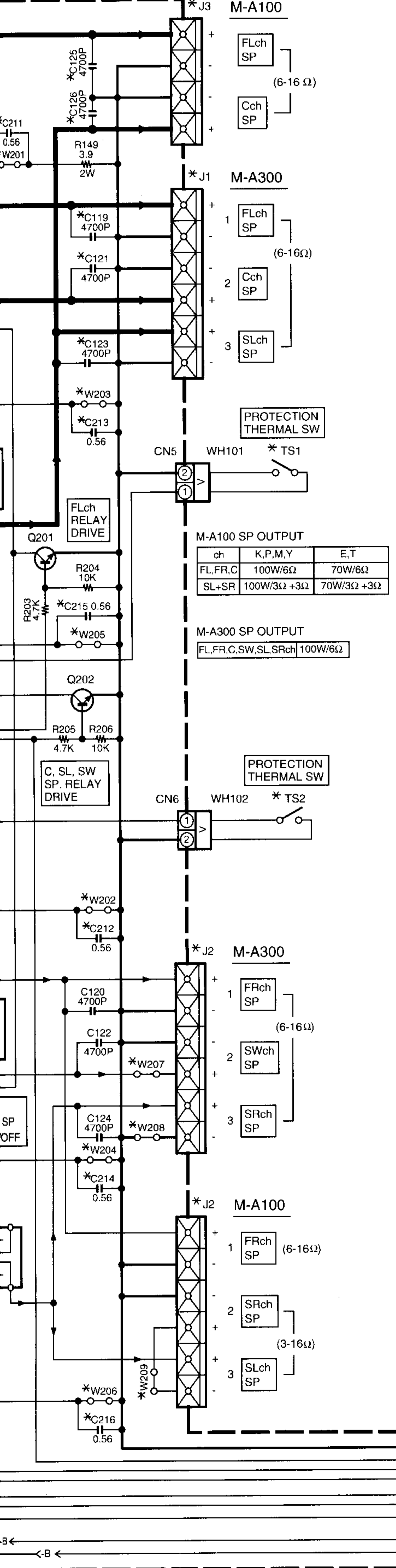

M-A100

DESTINATION COUNTRY	ABB	UNIT No.	Q101,102, 105,106	Q103,104, 109,110	Q107,108, 111,112	C17,18	C107,108, 111,112
U.S.A.	K	X07-2910-10	TRAI TR4N		TRAI TR4P		0.56
CANADA	P						
EUROPE	E	X07-2912-71	TRAI TR3N		TRAI TR3P		
U.K.	T						
PX	Y	X07-2912-91		NO		5600u63	0.33
CHINA	C	X07-2923-00	TRAI TR4N		TRAI TR4P		
AUSTRALIA	X						
GENERAL MARKET MALAYSIA	M	X07-2920-21					

M-A300

DESTINATION COUNTRY	ABB	UNIT No.	Q101-106	Q107-112	C17,18	C107-112	C119,121, 123
U.S.A.	K	X07-2910-11					0.56
CANADA	P						
EUROPE	E	X07-2912-72					
U.K.	T						
PX	Y	X07-2912-92	TRAI TR4N	TRAI TR4P	6800u63		YES
CHINA	C	X07-2923-01				0.33	
AUSTRALIA	X						
GENERAL MARKET MALAYSIA	M	X07-2920-22					

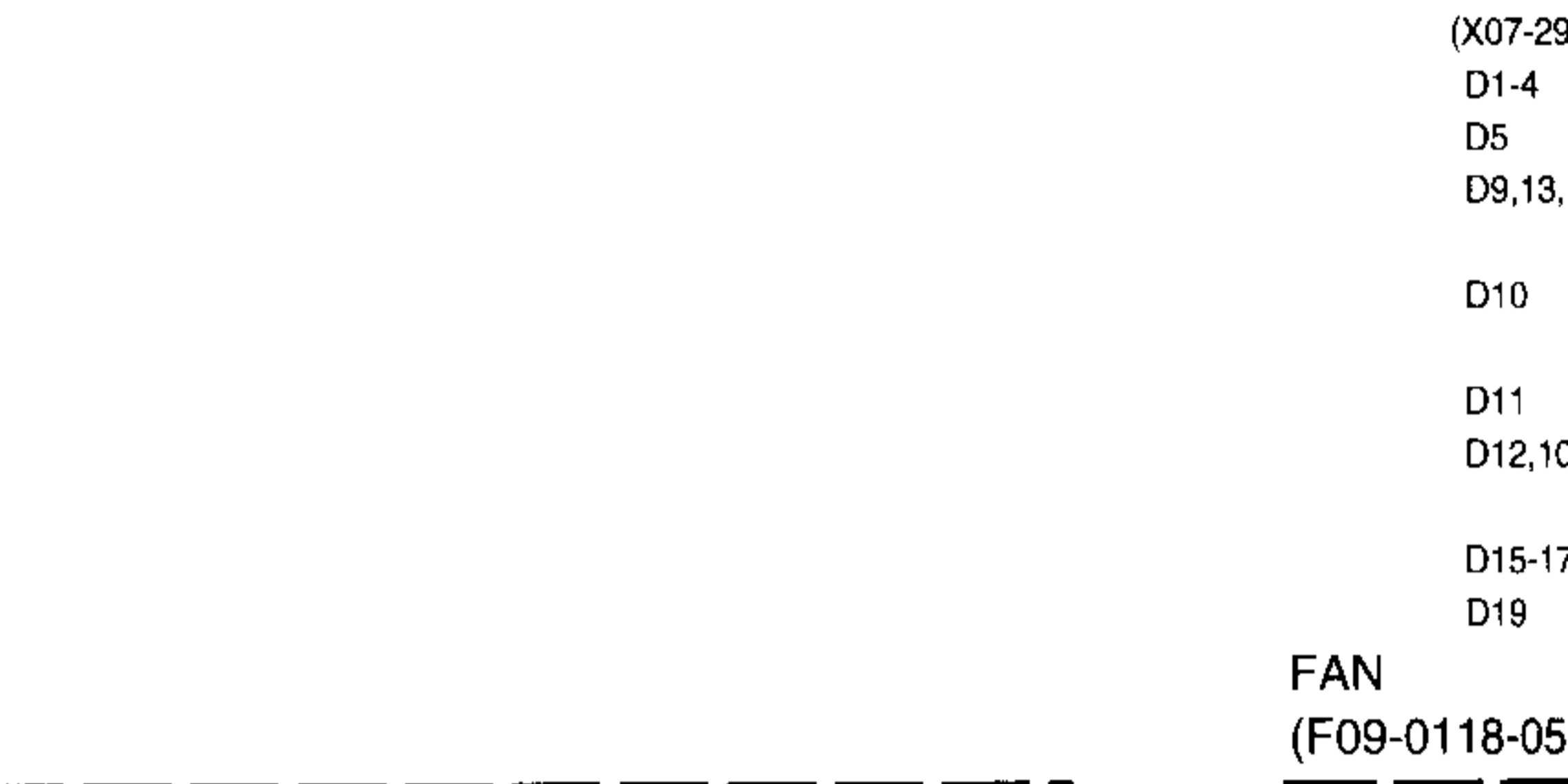

(X07-) (C/4)

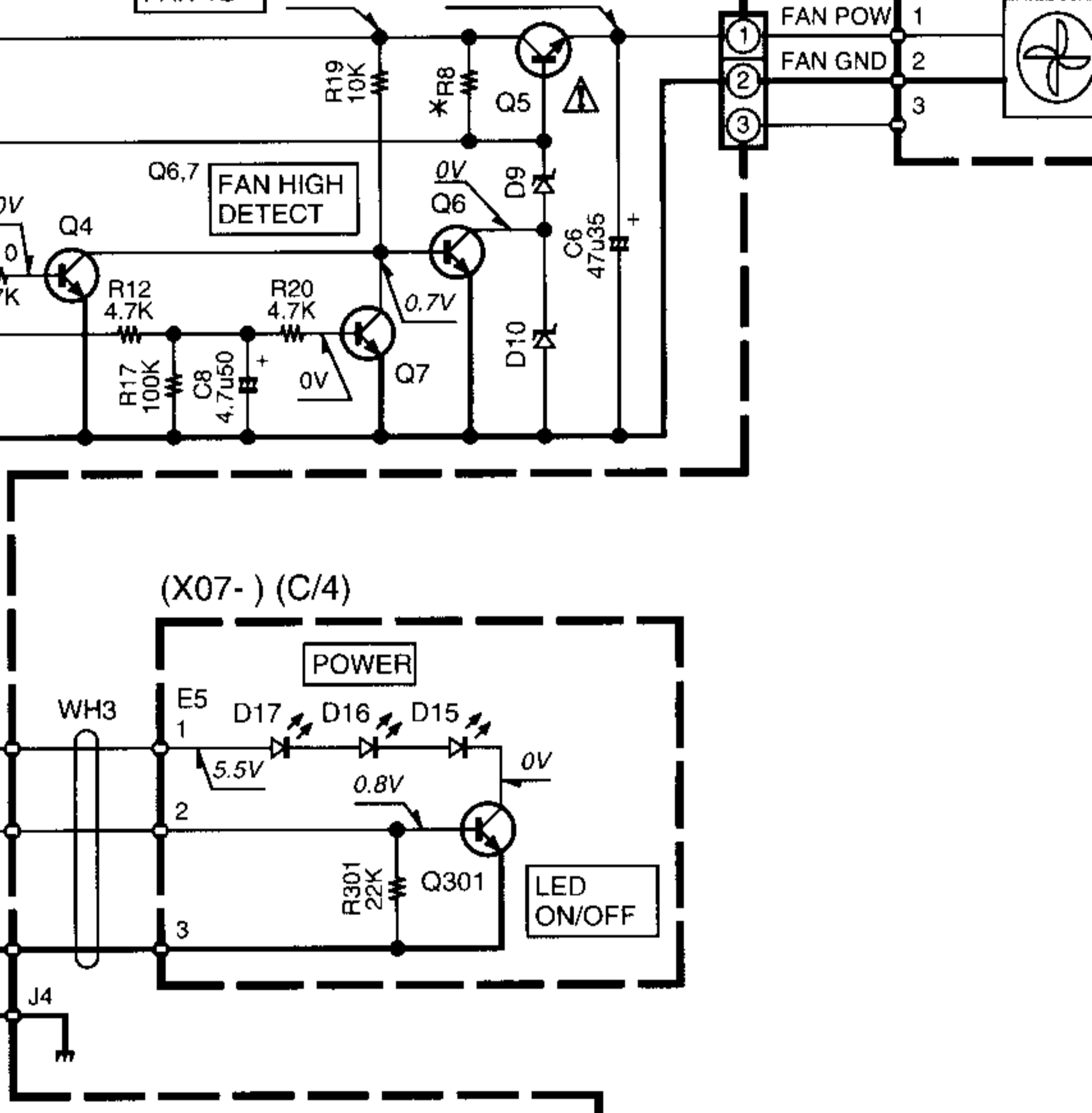

(X07-) (B/4)

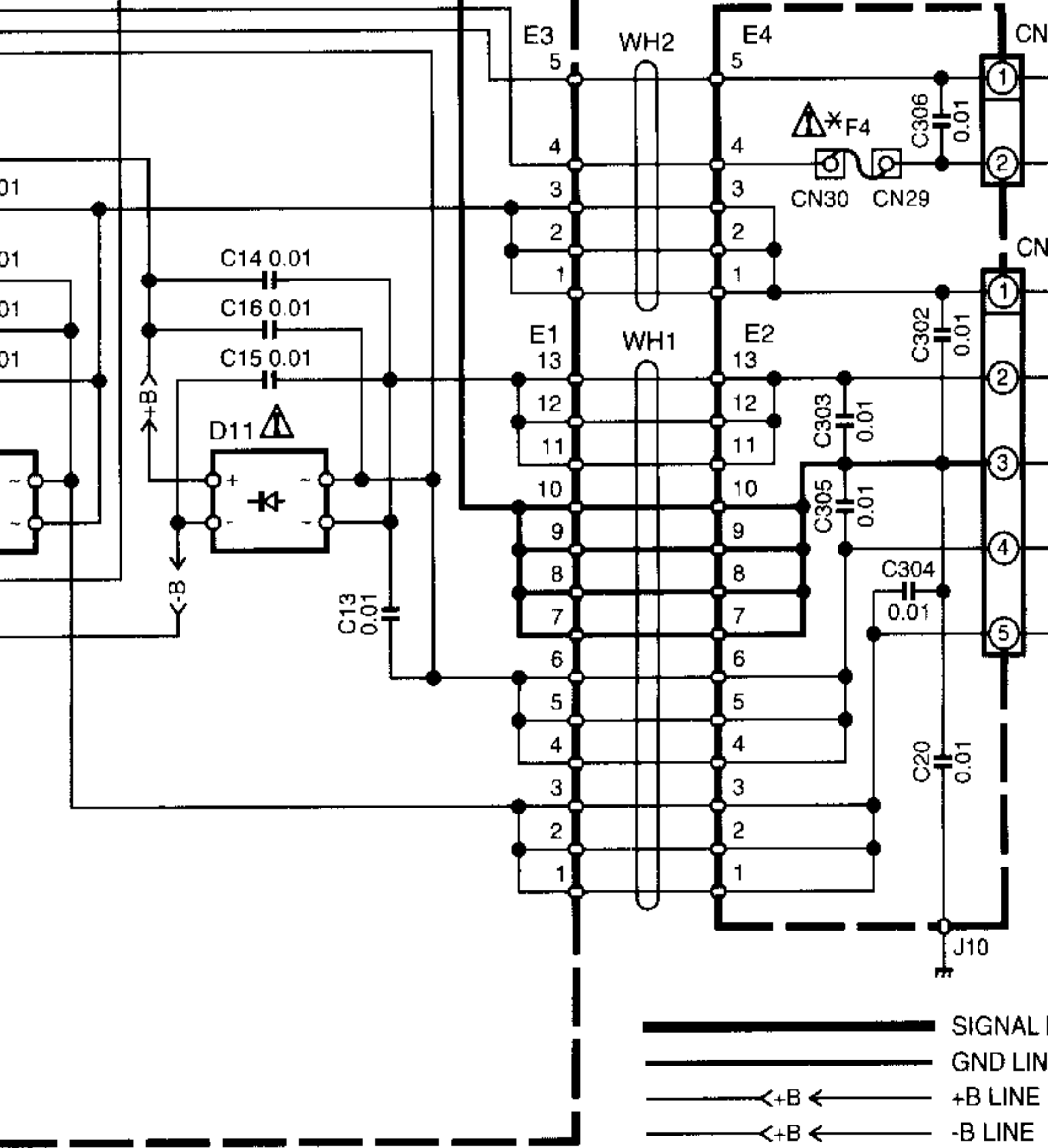

SIGNAL  
GND LINE  
+B LINE  
-B LINE

M-A100

DESTINATION		UNIT No.	Q101,102,105,106	Q103,104,109,110	Q107,108,111,112	C17,18	C107,108,111,112	C109,110,119,121,123,213,214	C125,126	C211,212,215,216	R8	R232	J1	J3	A, B	F4	W201-202,205,206	W203,204,207,208	W209	TS1,2
COUNTRY	ABB																			
U.S.A.	K	X07-2910-10	TRAITR4N		TRAITR4P		0.56			0.56	2.2K 1W					1A 125V	NO			
CANADA	P																			
EUROPE	E	X07-2912-71	TRAITR3N		TRAITR3P															
U.K.	T																			
PX	Y	X07-2912-91		NO		5600u63		NO	YES		1.8K 1W	270 2W	NO	YES	NO	T800mAL 250V	YES	NO	YES	S51-1518-05
CHINA	C	X07-2923-00	TRAITR4N		TRAITR4P		0.33													
AUSTRALIA	X																			
GENERAL MARKET	M	X07-2920-21																		
MALAYSIA	I																			

M-A300

DESTINATION		UNIT No.	Q101-106	Q107-112	C17,18	C107-112	C119,121,123	C125,126	C211,212,215,216	R8	R232	J1	J3	A, B	F4	W201-206	W207,208	W209	TS1,2
COUNTRY	ABB																		
U.S.A.	K	X07-2910-11				0.56			0.56	2.2K 1W					1A 125V	NO			
CANADA	P																		
EUROPE	E	X07-2912-72																	
U.K.	T																		
PX	Y	X07-2912-92	TRAITR4N	TRAITR4P	6800u63	0.33	YES	NO	NO	1.8K 1W	560 2W	YES	NO	YES	T800mAL 250V	YES	YES	NO	S79-0020-05
CHINA	C	X07-2923-01																	
AUSTRALIA	X																		
GENERAL MARKET	M	X07-2920-22																	
MALAYSIA	I																		

- (X07-29XX-XX)
- D1-4 : S5688B or 1SR139-400
  - D5 : D5SBA20F03 or RBV-602LFA
  - D9,13,14,208 : RD13ES(B2) or HZS13N(B2) or MTZJ13(B) or UZ-13BSB
  - D10 : RD11ES(B2) or HZS11N(B2) or MTZJ11(B) or UZ-11BSB
  - D11 : S15VB20
  - D12,101-112,201-207,209,210 : 1SS131 or HSS104A
  - D15-17 : B30-2493-05
  - D19 : RD4.7ES(B2) or HZS4.7N(B2) or MTZJ4.7(B) or UZ-4.7BSB
- Q1 : 2SC3940A(R,S)  
Q3,4,6-8,205,207,208,301-303 : 2SC2458(Y,GR) or 2SC3311A(Q,R) or 2SC1740S(Q,R) or 2SC2785(F,E)  
Q5 : 2SD2012 or 2SD2061  
Q113-118 : 2SC1845(F,E)  
Q201,202,206 : 2SC2003(L,K)  
Q203 : 2SA992(F,E)  
Q204 : 2SA954(L,K)  
Q101,102,105,106 : \*  
Q103,104,109,110 : \*  
Q107,108,111,112 : \*
- IC1 : uPC1237HA

**CAUTION:** For components only with same type and impedance type voltage measurement value shall be carried out from the supply circuit of the customer.

The DC voltage is an impedance type voltage measurement value shall be carried out from the supply circuit of the customer.

FAN (F09-0118-05)

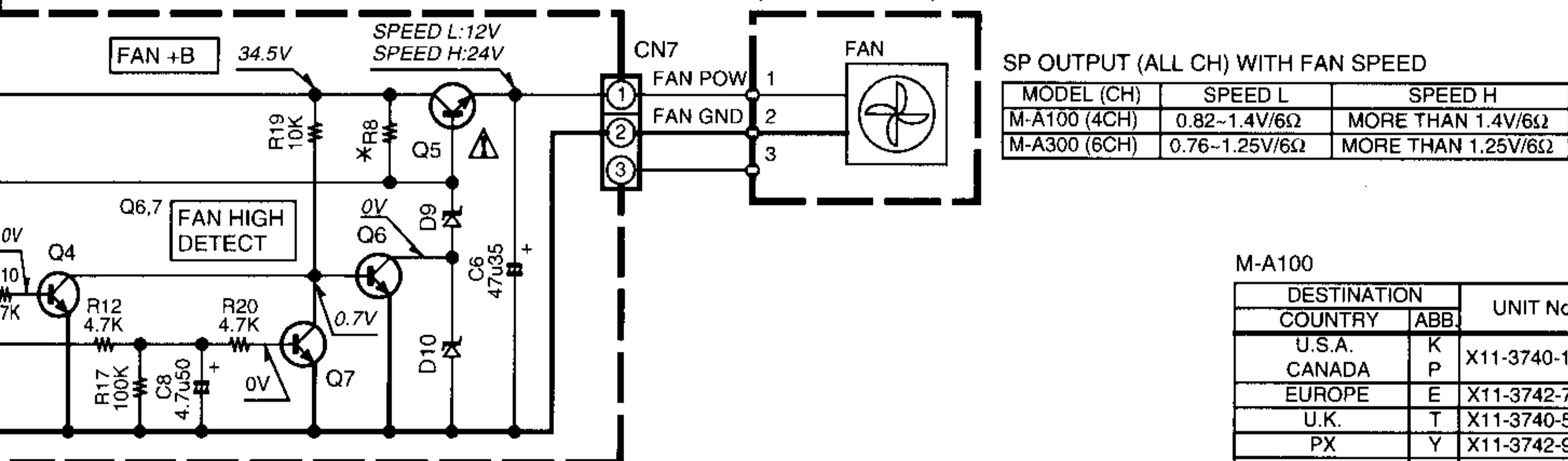

(X07-) (C/4)

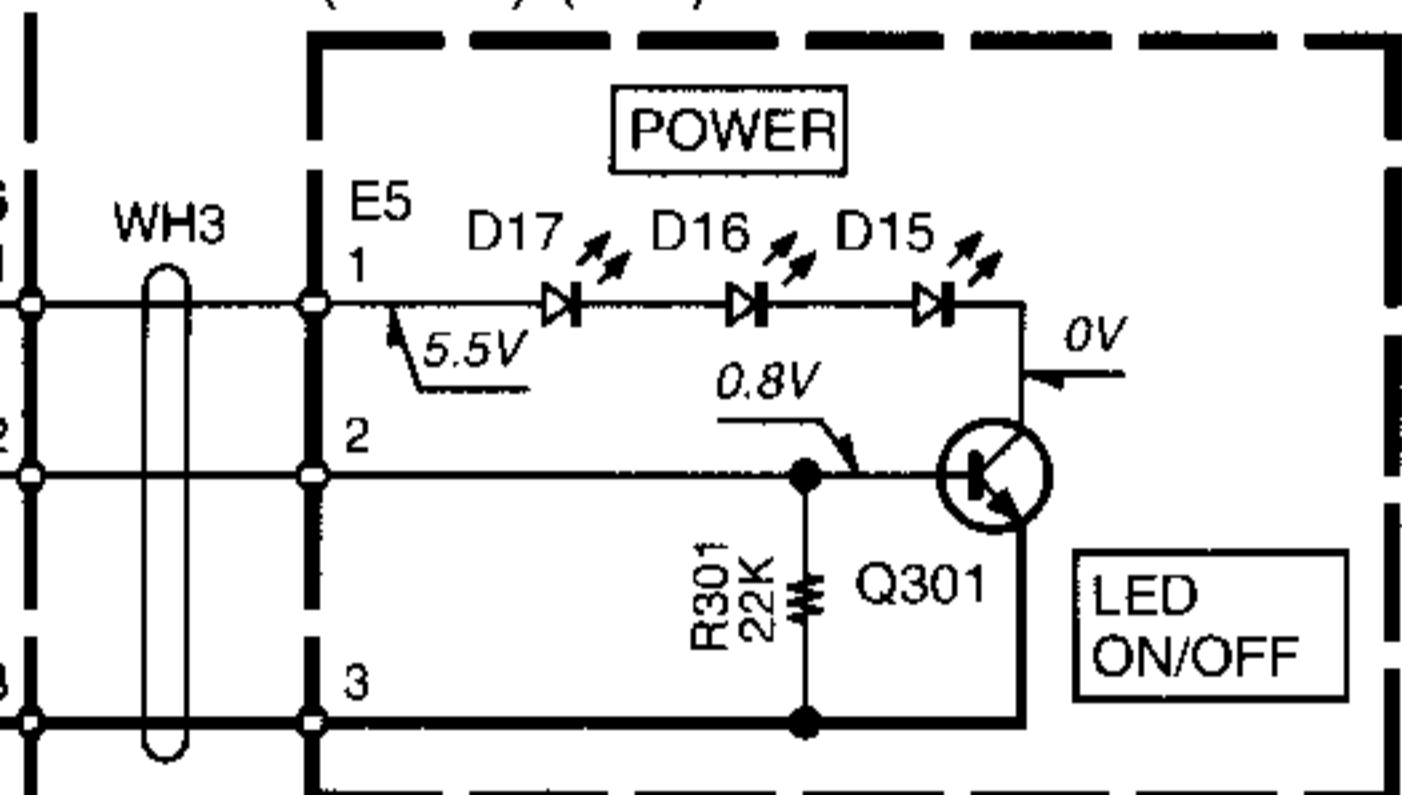

M-A100

DESTINATION		UNIT No.	W1	F1	CN1,2	J2	CN5	F2
COUNTRY	ABB							
U.S.A.	K	X11-3740-10	YES	NO	NO	E03-0316-05	E40-8126-05	F50-0077-05
CANADA	P							
EUROPE	E	X11-3742-71	NO	YES	YES	E03-0305-05		
U.K.	T	X11-3740-51				E03-0109-05		
PX	Y	X11-3742-91				E03-0316-05		
GENERAL MARKET	M	X11-3770-21	YES	NO	NO	E03-0305-05	E40-4245-05	F05-4025-05
MALAYSIA	I							
CHINA	C	X11-3773-00				E03-0337-05		
AUSTRALIA	X	X11-3770-71				E03-0325-05		

M-A300

DESTINATION		UNIT No.	W1	F1	CN1,2	J2	CN5	F2
COUNTRY	ABB							
U.S.A.	K	X11-3740-11	YES	NO	NO	E03-0316-05	E40-8126-05	F50-0078-05
CANADA	P							
EUROPE	E	X11-3742-72	NO	YES	YES	E03-0305-05		F05-6321-05
U.K.	T	X11-3740-52				E03-0109-05		
PX	Y	X11-3742-92				E03-0316-05		
GENERAL MARKET	M	X11-3770-22	YES	NO	NO	E03-0305-05	E40-4245-05	F05-5025-05
MALAYSIA	I							
CHINA	C	X11-3773-01				E03-0337-05		F05-6021-05
AUSTRALIA	X	X11-3770-72				E03-0325-05		

- 2SA1123
- 2SA954
- 2SA992
- 2SC1845
- 2SC2003
- 2SC2631

- 2SA1048
- 2SC1740S
- 2SC2458

- 2SA1309
- 2SC3311

- TRAITR3N
- TRAITR3P
- TRAITR4N
- TRAITR4P

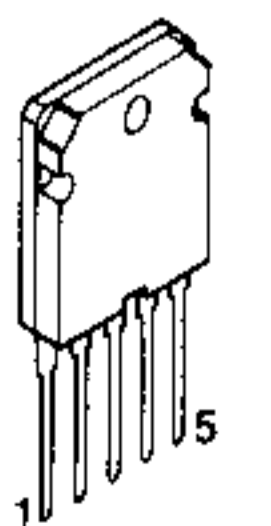

M-A

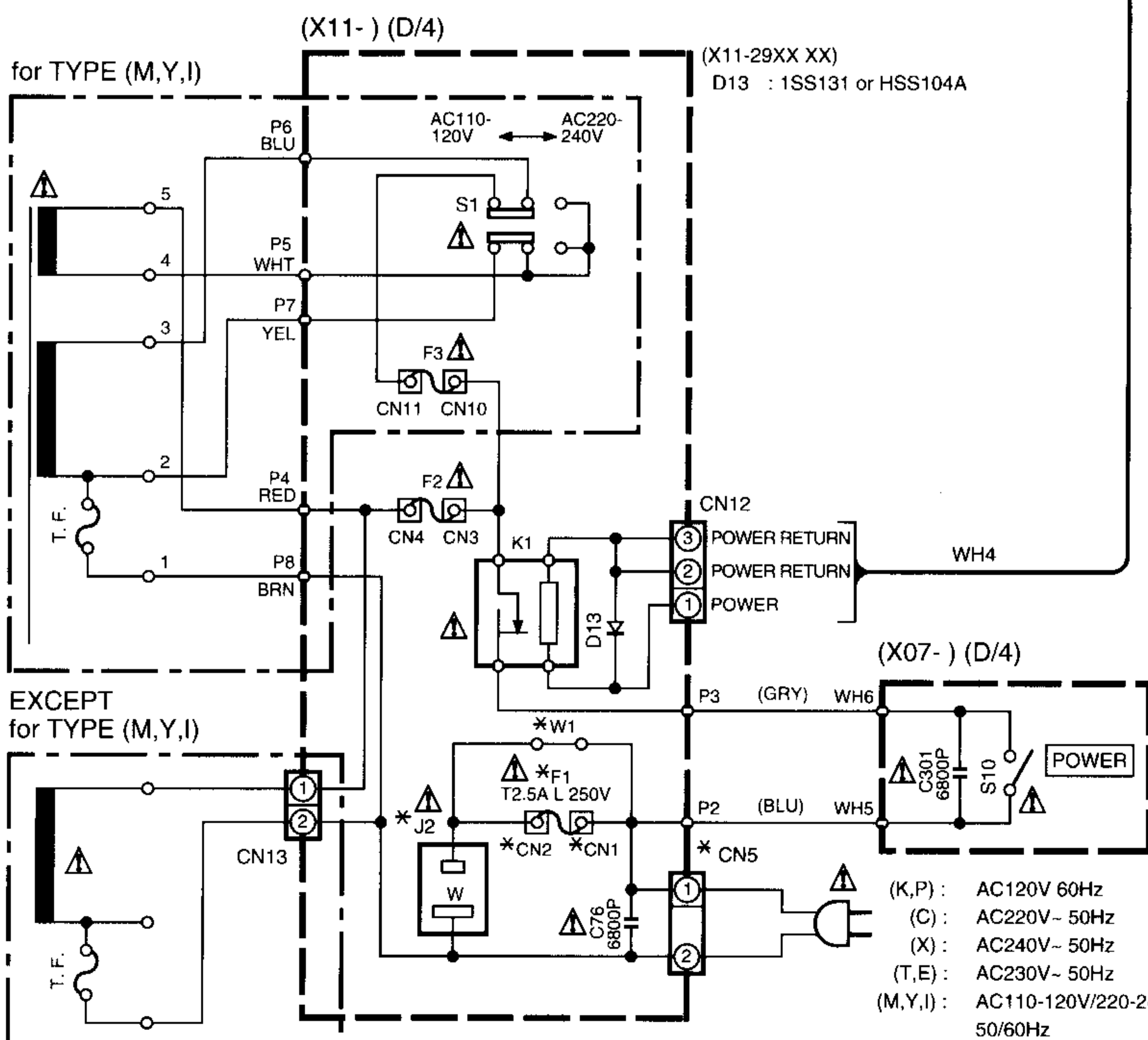

M-A100/A300(K) (2/2)

110,119,121,213,214	C125,126	C211,212,215,216	R8	R232	J1	J3	(A) (B)	F4	W201-202,205,206	W203,204,207,208	W209	TS1,2
NO	YES	0.56 NO	2.2K 1W 1.8K 1W	270 2W	NO	YES	NO	1A 125V T800mAL 250V	NO YES	NO	YES	S51-1518-05

211,212,215,216	R8	R232	J1	J3	(A) (B)	F4	W201-206	W207,208	W209	TS1,2
0.56 NO	2.2K 1W 1.8K 1W	560 2W	YES	NO	YES	1A 125V T800mAL 250V	NO YES	YES	NO	S79-0020-05

- Q1 : 2SC3940A(R,S)
- Q3,4,6-8,205,207,208,301-303 : 2SC2458(Y,GR) or 2SC3311A(Q,R) or 2SC1740S(Q,R) or 2SC2785(F,E)
- Q5 : 2SD2012 or 2SD2061
- Q113-118 : 2SC1845(F,E)
- Q201,202,206 : 2SC2003(L,K)
- Q203 : 2SA992(F,E)
- Q204 : 2SA954(L,K)
- Q101,102,105,106 : \*
- Q103,104,109,110 : \*
- Q107,108,111,112 : \*
- IC1 : uPC1237HA

OUTPUT (ALL CH) WITH FAN SPEED

MODEL (CH)	SPEED L	SPEED H
M-A100 (4CH)	0.82-1.4V/6Ω	MORE THAN 1.4V/6Ω
M-A300 (6CH)	0.76-1.25V/6Ω	MORE THAN 1.25V/6Ω

M-A100

DESTINATION		UNIT No.	W1	F1	CN1,2	J2	CN5	F2
COUNTRY	ABB							
U.S.A.	K	X11-3740-10	YES	NO	NO	E03-0316-05	E40-8126-05	F50-0077-05
CANADA	P	X11-3740-10	NO	NO	NO	E03-0316-05		
EUROPE	E	X11-3742-71	NO	YES	YES	E03-0305-05	E40-4245-05	F05-4025-05
U.K.	T	X11-3740-51	NO	NO	NO	E03-0109-05		
	Y	X11-3742-91	NO	NO	NO	E03-0316-05		
GENERAL MARKET	M	X11-3770-21	YES	NO	NO	E03-0305-05	E40-4245-05	F05-4025-05
MALAYSIA	I	X11-3770-21	NO	NO	NO	E03-0305-05		
CHINA	C	X11-3773-00	NO	NO	NO	E03-0337-05		
AUSTRALIA	X	X11-3770-71	NO	NO	NO	E03-0325-05		

M-A300

DESTINATION		UNIT No.	W1	F1	CN1,2	J2	CN5	F2
COUNTRY	ABB							
U.S.A.	K	X11-3740-11	YES	NO	NO	E03-0316-05	E40-8126-05	F50-0078-05
CANADA	P	X11-3740-11	NO	NO	NO	E03-0316-05		
EUROPE	E	X11-3742-72	NO	YES	YES	E03-0305-05	E40-4245-05	F05-6321-05
U.K.	T	X11-3740-52	NO	NO	NO	E03-0109-05		
	Y	X11-3742-92	NO	NO	NO	E03-0316-05		
GENERAL MARKET	M	X11-3770-22	YES	NO	NO	E03-0305-05	E40-4245-05	F05-5025-05
MALAYSIA	I	X11-3770-22	NO	NO	NO	E03-0305-05		
CHINA	C	X11-3773-01	NO	NO	NO	E03-0337-05		
AUSTRALIA	X	X11-3770-72	NO	NO	NO	E03-0325-05		F05-6021-05

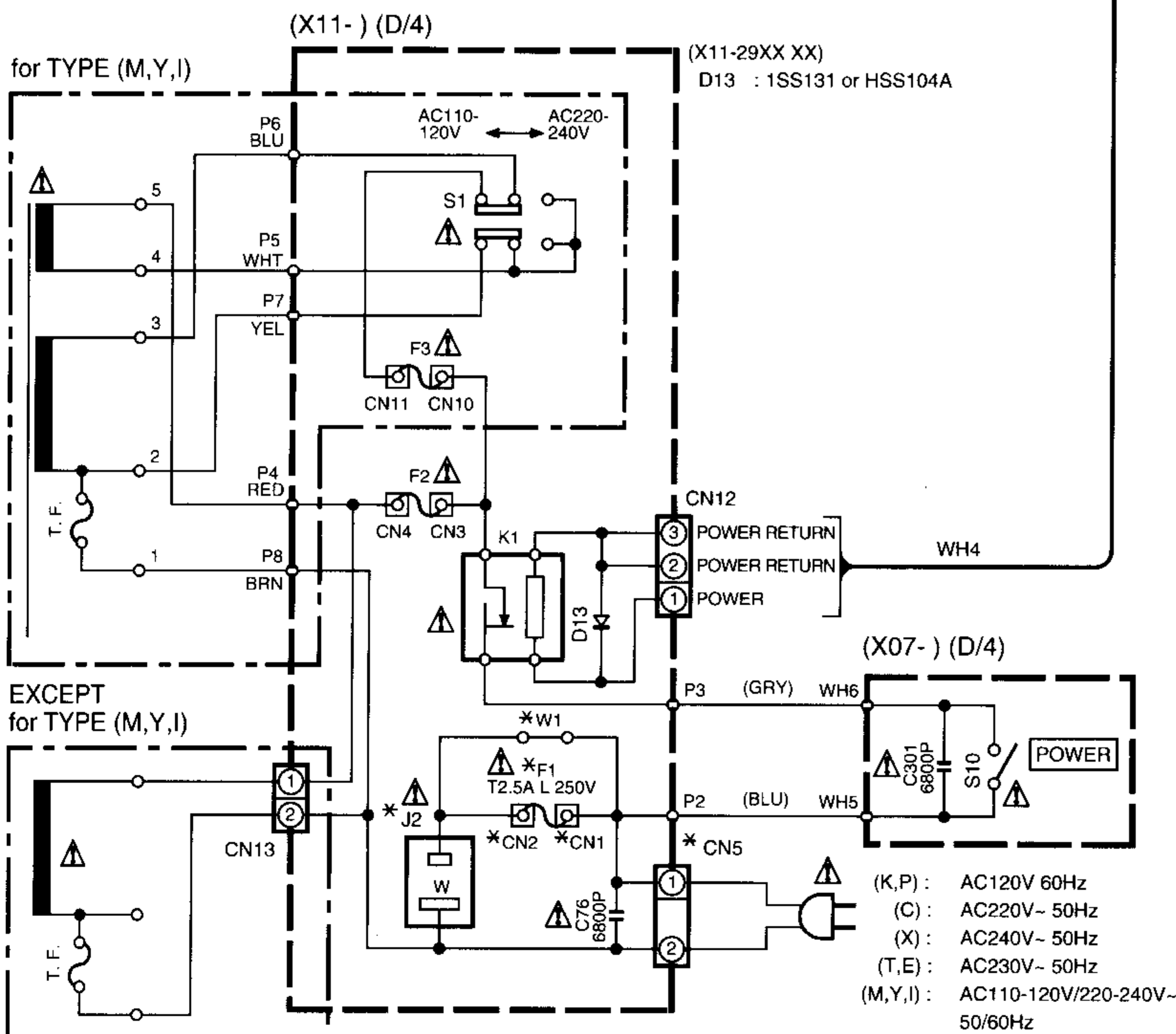

M-A100/A300(K) (2/2)

**CAUTION:** For continued safety, replace safety critical components only with manufacturer's recommended parts (refer to parts list).  $\Delta$  indicates safety critical components. For continued protection against risk of fire, replace only with same type and rating fuse(s). To reduce the risk of electric shock, leakage-current or resistance measurements shall be carried out (exposed parts are acceptably insulated from the supply circuit) before the appliance is returned to the customer.

The DC voltage is an actual reading measured with a high impedance type voltmeter with no signal input. The measurement value may vary depending on the measuring instruments used or on the product.

- 2SA1123
- 2SA954
- 2SA992
- 2SC1845
- 2SC2003
- 2SC2631

- 2SC2878
- 2SC3940A
- 2SD863

- 2SD2061

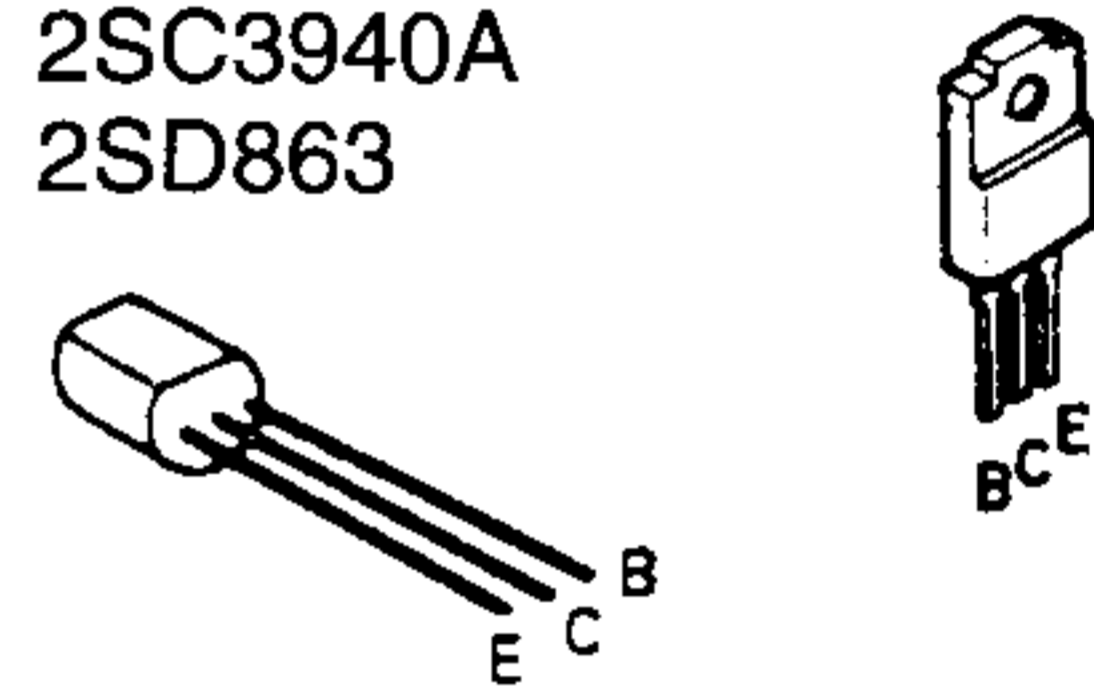

- 2SA1048
- 2SC1740S
- 2SC2458

- 2SA1175
- 2SC2785

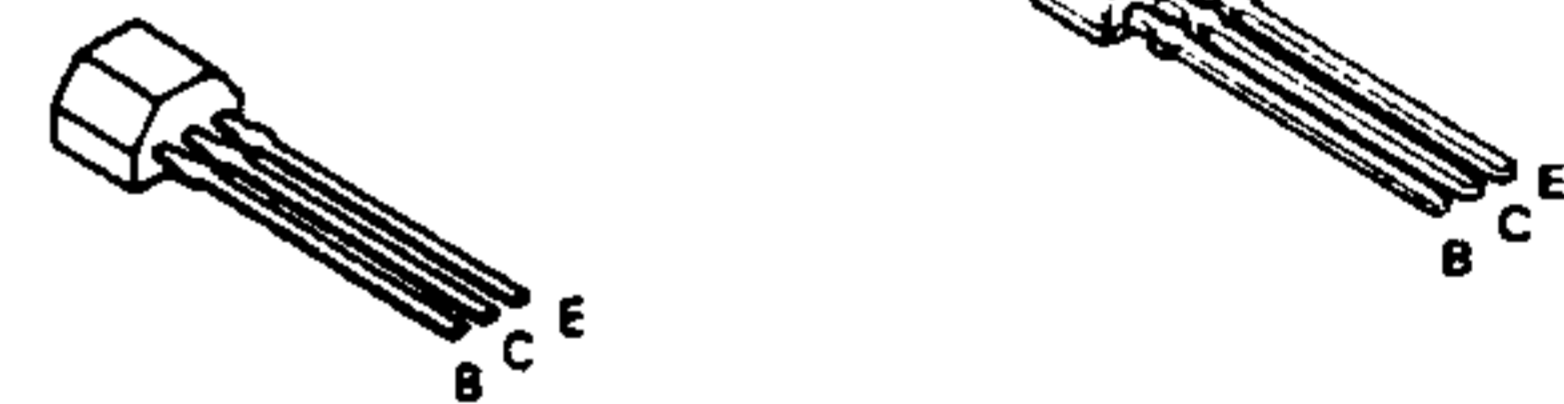

- 2SA1309A
- 2SC3311A

- 2SD2012

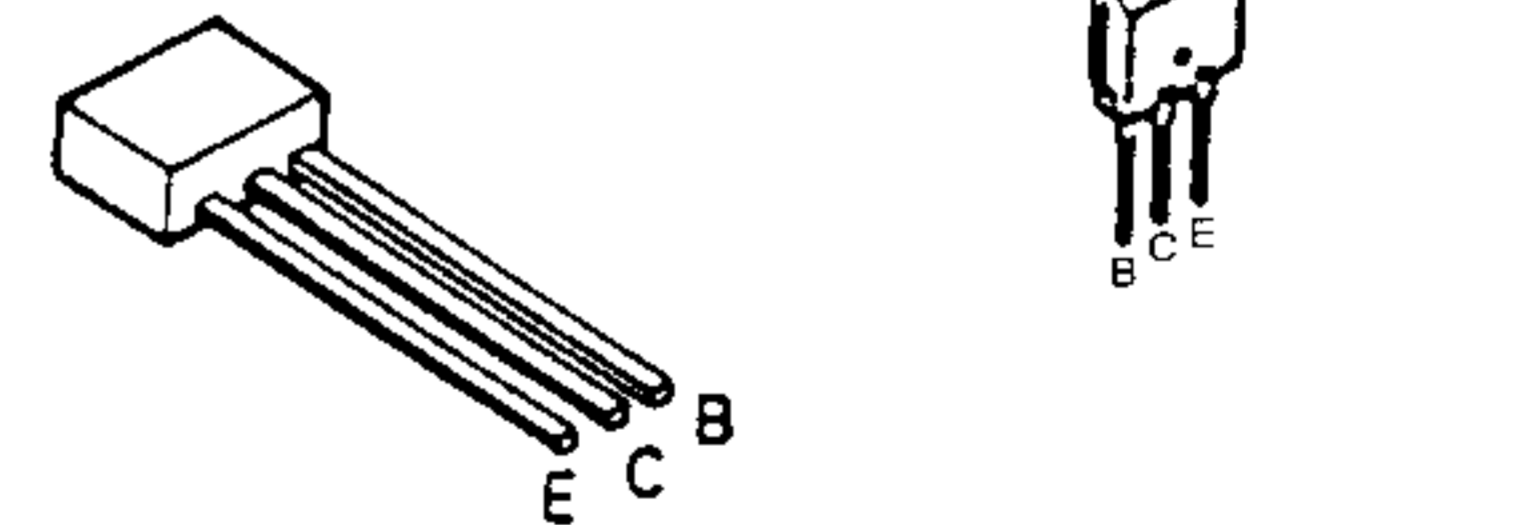

- TRAITR3N
- TRAITR3P
- TRAITR4N
- TRAITR4P

- UPC1237HA



# M-A100/A300

# M-A100/A300

## EXPLODED VIEW(UNIT)

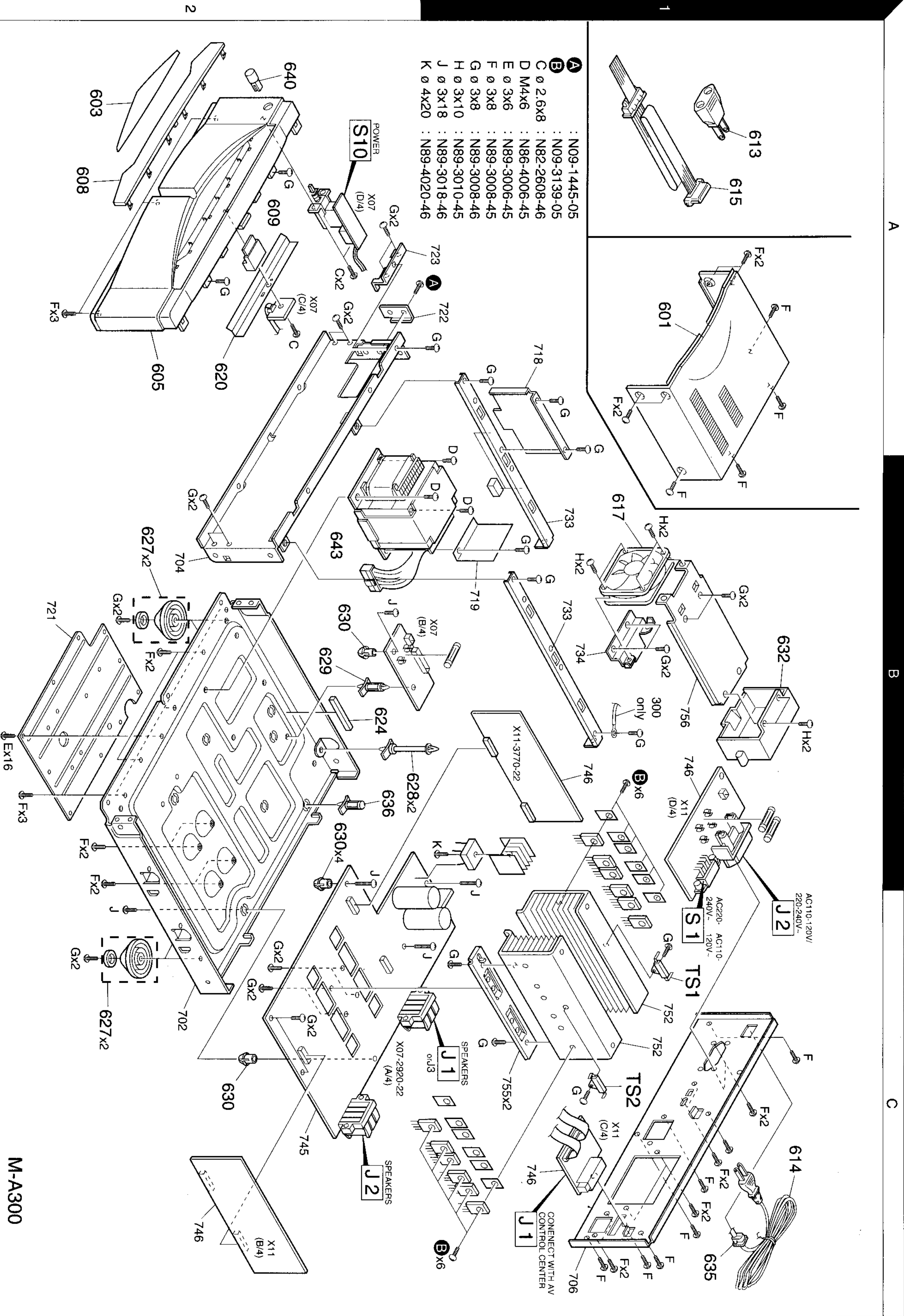

M-A300

# M-A100/A300

\* New Parts  
Parts without **Parts No.** are not supplied.  
Les articles non mentionnés dans le **Parts No.** ne sont pas fournis.  
Teile ohne **Parts No.** werden nicht geliefert.

Ref. No	Add-ress	New Parts	Parts No.	Description	Desti-nation	Re-marks
<b>M-A100/A300</b>						
601	1A	*	A01-3429-01	METALLIC CABINET		
603	2A	*	A21-1950-03	DRESSING PANEL(300)	KPYTE	
603	2A	*	A21-1956-03	DRESSING PANEL(100)	KPYTE	
605	2A	*	A60-1130-01	PANEL (300)	CIMX	
605	2A	*	A60-1221-01	PANEL (100)	CIMX	
605	2A	*	A60-1228-01	PANEL (300)		
605	2A	*	A60-1229-01	PANEL (100)		
608	2A	*	B07-2340-02	ESCUITCHEON	KPYTE	
608	2A	*	B07-2378-02	ESCUITCHEON	CIMX	
609	2A	*	B12-0308-04	INDICATOR	X	
			B46-0096-53	WARRANTY CARD	TE	
			B46-0310-03	WARRANTY CARD	C	
			B46-0326-53	WARRANTY CARD	KY	
			B46-0328-03	WARRANTY CARD	P	
			B46-0336-03	WARRANTY CARD	Y	
			B58-0513-04	CAUTION CARD (PRESET220-240)	T	
			B58-0945-03	CAUTION CARD		
			B58-0964-13	CAUTION CARD (UL)	KY	
			B58-0965-13	CAUTION CARD (PL)	TX	
			B58-0966-13	CAUTION CARD (PL)	EMI	
			B58-0967-03	CAUTION CARD (PL)	P	
			B58-1546-03	CAUTION CARD (300)	C	
			B59-1104-00	SERVICE DIRECTORY	Y	
		*	B60-3340-00	INSTRUCTION MANUAL(ENG)	KPYTGI	
		*	B60-3340-00	INSTRUCTION MANUAL(ENG)	MX	
		*	B60-3341-00	INSTRUCTION MANUAL(FRN)	PE	
		*	B60-3342-00	INSTRUCTION MANUAL(SPN)	EM	
		*	B60-3343-00	INSTRUCTION MANUAL(G/I/N)	E	
		*	B60-3346-00	INSTRUCTION MANUAL(CHN)	C	
		*	B60-3347-00	INSTRUCTION MANUAL(TWN)	MI	
613	1A	*	E03-0115-05	AC PLUG ADAPTER	MI	
614	1C	*	E30-2592-05	AC POWER CORD	MI	
614	1C	*	E30-2717-05	AC POWER CORD	X	
614	1C	*	E30-2787-05	AC POWER CORD	KP	
614	1C	*	E30-2788-05	AC POWER CORD	E	
614	1C	*	E30-2789-05	AC POWER CORD	Y	
614	1C	*	E30-2791-05	AC POWER CORD	T	
614	1C	*	E30-2830-05	AC POWER CORD	C	
615	1A	*	E30-2857-05	CORD WITH CONNECTOR		
617	1B	*	F09-0118-05	FAN		
620	2A	*	F19-1078-03	BLIND PLATE		
624	2B	*	G11-2320-04	CUSHION	KPYTE	
624	2B	*	G11-2322-04	CUSHION	CIMX	
		*	H10-7284-02	POLYSTYRENE FOAMED FIXTURE	KPYE	
		*	H10-7285-02	POLYSTYRENE FOAMED FIXTURE	KPYE	
		*	H10-7324-02	POLYSTYRENE FOAMED FIXTURE	T	
		*	H10-7325-02	POLYSTYRENE FOAMED FIXTURE	T	
		*	H10-7326-02	POLYSTYRENE FOAMED FIXTURE	CIMX	
		*	H10-7327-02	POLYSTYRENE FOAMED FIXTURE	CIMX	
		*	H11-0082-04	POLYSTYRENE FOAMED BOARD		
		*	H13-0272-04	CARTON BOARD	X	

L : Scandinavia  
Y : PX(Far East, Hawaii)  
Y : AAFES(Europe)

K : USA  
T : Europe  
X : Australia

P : Canada  
E : Europe  
M : Other Areas

R : Mexico  
G : Germany  
Q : Russia

⚠ indicates safety critical components.

\* New Parts  
Parts without **Parts No.** are not supplied.  
Les articles non mentionnés dans le **Parts No.** ne sont pas fournis.  
Teile ohne **Parts No.** werden nicht geliefert.

Ref. No	Add-ress	New Parts	Parts No.	Description	Desti-nation	Re-marks
			H25-0232-04	PROTECTION BAG (235X350X0.03)	KPYECI	
			H25-0232-04	PROTECTION BAG (235X350X0.03)	MX	
			H25-0651-04	PROTECTION BAG	T	
			H25-1516-04	PROTECTION BAG		
			H30-0100-04	ADHESIVE DOUBLE-COATED TAPE	KPYTE	
		*	H30-0602-04	ADHESIVE DOUBLE-COATED TAPE		
		*	H50-2322-04	ITEM CARTON CASE (300)	CIMX	
		*	H50-2323-04	ITEM CARTON CASE (300)	KPYE	
		*	H50-2324-04	ITEM CARTON CASE (100)	T	
		*	H50-2325-04	ITEM CARTON CASE (100)	KPYE	
		*	H50-2445-04	ITEM CARTON CASE (300)	MI	
		*	H50-2446-04	ITEM CARTON CASE (300)	C	
		*	H50-2447-04	ITEM CARTON CASE (300)	X	
		*	H50-2448-04	ITEM CARTON CASE (100)	MI,	
		*	H50-2449-04	ITEM CARTON CASE (100)	C	
		*	H50-2450-04	ITEM CARTON CASE (100)	X	
627	2B,2C		J02-1188-03	FOOT	KPYTE	
627	2B,2C	*	J02-1189-03	FOOT	CIMX	
628	1B		J19-3208-05	UNIT HOLDER		
629	2B		J19-3325-05	UNIT HOLDER	KPYTE	
630	2B,2C		J19-3732-04	UNIT HOLDER		
630	2B,2C		J19-3751-04	UNIT HOLDER	CIMX	
632	1B	*	J19-5791-02	HOLDER		
635	1C		J42-0083-05	POWER CORD BUSHING		
636	2B		J19-2588-05	UNIT HOLDER	KPYTE	
			J61-0098-05	WIRE BAND		
			J61-0307-05	WIRE BAND	CIMX	
640	2A	*	K27-2211-04	KNOB (BUTTON)		
643	2B	*	L07-2312-05	POWER TRANSFORMER(100)	KP	
643	2B	*	L07-2313-05	POWER TRANSFORMER(100)	Y	
643	2B	*	L07-2314-05	POWER TRANSFORMER(100)	X	
643	2B	*	L07-2315-05	POWER TRANSFORMER(100)	TE	
643	2B	*	L07-2316-05	POWER TRANSFORMER(300)	KP	
643	2B	*	L07-2317-05	POWER TRANSFORMER(300)	Y	
643	2B	*	L07-2318-05	POWER TRANSFORMER(300)	X	
643	2B	*	L07-2319-05	POWER TRANSFORMER(300)	TE	
643	2B	*	L07-2347-05	POWER TRANSFORMER(100)	C	
643	2B	*	L07-2348-05	POWER TRANSFORMER(300)	C	
643	2B	*	L07-2417-05	POWER TRANSFORMER(300)	MI	
643	2B	*	L07-2418-05	POWER TRANSFORMER(100)	MI	
<b>POWER (X07-2910-10/X07-2923-00)</b>						
D15-17			B30-2493-05	LED(RED)		
C1-2			CE04KW1H100M	ELECTRO	10UF	50WV
C5			CE04KW1H2R2M	ELECTRO	2.2UF	50WV
C6			CE04KW1V470M	ELECTRO	47UF	35WV
C7			CE04KW1H100M	ELECTRO	10UF	50WV
C8			CE04KW1H4R7M	ELECTRO	4.7UF	50WV
C9-12			CK45FF1H103Z	CERAMIC	0.010UF	Z
C13-16			CK45FE2H103P	CERAMIC	0.010UF	P
C17-18	100	*	C90-3737-05	ELECTRO	5600UF	63WV
C17-18	300	*	C90-3738-05	ELECTRO	6800UF	63WV
C20			CK45FF1H103Z	CERAMIC	0.010UF	Z

L : Scandinavia  
Y : PX(Far East, Hawaii)  
Y : AAFES(Europe)

K : USA  
T : Europe  
X : Australia

P : Canada  
E : Europe  
M : Other Areas

R : Mexico  
G : Germany  
Q : Russia

⚠ indicates safety critical components.

## PARTS LIST

\* New Parts  
Parts without **Parts No.** are not supplied.  
Les articles non mentionnés dans le **Parts No.** ne sont pas fournis.  
Teile ohne **Parts No.** werden nicht geliefert.

Ref. No	Add-ress	New Parts	Parts No.	Description	Desti-nation	Re-marks
W203,204	300		E31-0001-00	JUMPER WIRE	YTECIM	
W207,208	300		E31-0001-00	JUMPER WIRE		
W209	100		E31-0001-00	JUMPER WIRE		
F4			F05-8013-05	FUSE (SEMKO)	X	
F4			F05-8013-05	FUSE (SEMKO)	YTECIM	
F4			F50-0066-05	FUSE(5X20)	KP	
CN29,30			J13-0075-05	FUSE CLIP		
J4			J21-5845-04	MOUNTING HARDWARE		
L1 ,2			L39-0085-05	PHASE COMPENSATION COIL		
L3 ,4			L39-0085-05	PHASE COMPENSATION COIL		
L5 ,6			L39-0085-05	PHASE COMPENSATION COIL		
R4			RD14NB2E102J	RD	X	
R8			RS14KB3A182J	FL-PROOF RS	YTECIM	
R8			RS14KB3A182J	FL-PROOF RS	KP	
R8			RS14KB3A222J	FL-PROOF RS		
R18			RS14KB3A222J	FL-PROOF RS		
R101,102			RD14NB2E470J	RD		
R103,104			RD14NB2E470J	RD		
R105-108			RD14NB2E470J	RD		
R109,110			RD14NB2E470J	RD		
R111,112			RD14NB2E470J	RD		
R113,114			RD14NB2E101J	RD		
R115,116			RD14NB2E101J	RD		
R117,118			RD14NB2E101J	RD		
R121,122			RD14BB2C272J	RD		
R127,128			RD14BB2C621J	RD		
R133,134			RD14BB2C471J	RD		
R139,140			RD14BB2C103J	RD		
R145,146			RD14BB2C103J	RD		
R149,150			RS14KB3D3R9J	FL-PROOF RS		
R151,152			RS14KB3D3R9J	FL-PROOF RS		
R153,154			RS14KB3D3R9J	FL-PROOF RS		
R155,156			RD14NB2E100J	RD		
R157,158			RD14NB2E100J	RD		
R159,160			RD14NB2E100J	RD		
R201,202			RS14KB3D561J	FL-PROOF RS		
R216			RS14KB3A222J	FL-PROOF RS		
R221			RS14KB3D561J	FL-PROOF RS		
R232			RS14KB3D271J	FL-PROOF RS		
R232			RS14KB3D561J	FL-PROOF RS		
R234			RS14KB3D561J	FL-PROOF RS		
R302			RS14KB3A222J	FL-PROOF RS		
VR1 ,2			R12-0605-05	TRIMMING POT.(220)		
VR3 ,4			R12-0605-05	TRIMMING POT.(220)		
VR5 ,6			R12-0605-05	TRIMMING POT.(220)		
K1 -4			S76-0056-05	MAGNETIC RELAY		
K5			S76-0063-05	MAGNETIC RELAY		
S10			S40-1094-05	PUSH SWITCH (POWER TYPE)		
TS1 ,2			S51-1518-05	RELAY ASSY		
TS1 ,2			S79-0020-05	THERMAL SWITCH		
D1 -4			S5688B	DIODE		
D1 -4			1SR139-400	DIODE		
D5			D5SBA20F03	DIODE		

\* New Parts  
Parts without **Parts No.** are not supplied.  
Les articles non mentionnés dans le **Parts No.** ne sont pas fournis.  
Teile ohne **Parts No.** werden nicht geliefert.

Ref. No	Add-ress	New Parts	Parts No.	Description	Desti-nation	Re-marks
C23			CE04KW1H471M	ELECTRO		
C24 -27			CK45FE2H103P	CERAMIC		
C101,102			CK45FF1H103Z	CERAMIC		
C103,104			CK45FF1H103Z	CERAMIC		
C105,106			CK45FF1H103Z	CERAMIC		
C107,108			CF92FV1H334J	MF-C	X	
C107,108			CF92FV1H334J	MF-C	YTECIM	
C107,108			CF92FV1H564J	MF-C	KP	
C109,110			CF92FV1H334J	MF-C	X	
C109,110			CF92FV1H334J	MF-C	YTECIM	
C109,110			CF92FV1H564J	MF-C	KP	
C111,112			CF92FV1H334J	MF-C	X	
C111,112			CF92FV1H334J	MF-C	YTECIM	
C113,114			CQ93FMG1H473J	MYLAR		
C115,116			CQ93FMG1H473J	MYLAR		
C117,118			CQ93FMG1H473J	MYLAR		
C119			CK45FF1H472Z	CERAMIC		
C120			CK45FF1H472Z	CERAMIC		
C121			CK45FF1H472Z	CERAMIC		
C122			CK45FF1H472Z	CERAMIC		
C123			CK45FF1H472Z	CERAMIC		
C124			CK45FF1H472Z	CERAMIC		
C125,126			CK45FF1H472Z	CERAMIC		
C201			CE04KW1C220M	ELECTRO		
C202			CE04KW1A221M	ELECTRO		
C203			CK45FF1H223Z	CERAMIC		
C204			CE04KW1H4R7M	ELECTRO		
C205			CE04KW1H330M	ELECTRO		
C206			CC45FSL1H221J	CERAMIC		
C207			CE04KW1H010M	ELECTRO		
C208			CE04KW1V330M	ELECTRO		
C211,212			CF92FV1H564J	MF-C	KP	
C213,214			CF92FV1H564J	MF-C	KP	
C215,216			CF92FV1H564J	MF-C	KP	
C301			C91-1488-05	MF		
C302-306			CK45FE2H103P	CERAMIC		
C307			CE04KW2A4R7M	ELECTRO		
CN1 ,2			E40-9842-05	PIN ASSY		
CN3			E40-9841-05	PIN ASSY		
CN4			E40-9844-05	PIN ASSY		
CN5 ,6			E40-3246-05	PIN ASSY		
CN7			E40-3247-05	PIN ASSY		
CN11,12			E40-4871-05	PIN ASSY		
CN13,14			E40-4871-05	PIN ASSY		
CN15,16			E40-4871-05	PIN ASSY		
CN101			E40-4245-05	PIN ASSY	CIMX	
CN101			E40-8126-05	PIN ASSY	KPYTE	
CN102			E40-4281-05	PIN ASSY	CIMX	
CN102			E40-8129-05	PIN ASSY	KPYTE	
J1			E70-0046-05	LOCK TERMINAL BOARD		
J2			E70-0046-05	LOCK TERMINAL BOARD		
J3			E70-0045-05	LOCK TERMINAL BOARD		
J3			E70-0053-05	LOCK TERMINAL BOARD		
W203,204			E31-0001-00	JUMPER WIRE	X	

L : Scandinavia  
Y : PX(Far East, Hawaii)  
Y : AAFES(Europe)

K : USA  
T : Europe  
X : Australia

P : Canada  
E : Europe  
M : Other Areas

R : Mexico  
G : Germany  
M : Other Areas

I : Malaysia  
C : China

100 : M-A100  
300 : M-A300

△ indicates safety critical components.



# M-A100/A300

## PARTS LIST

\* New Parts  
Parts without **Parts No.** are not supplied.  
Les articles non mentionnés dans le **Parts No.** ne sont pas fournis.  
Teile ohne **Parts No.** werden nicht geliefert.

5

Ref. No	Add-ress	New Parts	Parts No.	Description	Desti-nation	Re-marks
△ D5			RBV-602LFA	DIODE	KPYTE	
D9			HZS13N(B2)	ZENER DIODE	CIMX	
D9			MTZJ13(B)	ZENER DIODE	KPYTE	
△ D9			RD13ES(B2)	ZENER DIODE	CIMX	
△ D9			UZ-13BSB	ZENER DIODE	CIMX	
D10			HZS11N(B2)	ZENER DIODE	KPYTE	
D10			MTZJ11(B)	ZENER DIODE	CIMX	
D10			RD11ES(B2)	ZENER DIODE	KPYTE	
D10			UZ-11BSB	ZENER DIODE	CIMX	
△ D11			S15VB20	ZENER DIODE	CIMX	
D12			HSS104A	DIODE		
D12			1SS131	DIODE		
D13, 14			HZS13N(B2)	ZENER DIODE	KPYTE	
D13, 14			MTZJ13(B)	ZENER DIODE	CIMX	
△ D13, 14			RD13ES(B2)	ZENER DIODE	KPYTE	
D13, 14			UZ-13BSB	ZENER DIODE	CIMX	
D19			HZS4.7N(B2)	ZENER DIODE	KPYTE	
D19			MTZJ4.7(B)	ZENER DIODE	CIMX	
D19			RD4.7ES(B2)	ZENER DIODE	KPYTE	
△ D19			UZ-4.7BSB	ZENER DIODE	CIMX	
D101,102			HSS104A	DIODE		
D101,102			1SS131	DIODE		
D103,104	300		HSS104A	DIODE		
D103,104	300		1SS131	DIODE		
△ D105-108			HSS104A	DIODE		
D105-108			1SS131	DIODE		
D109,110	300		HSS104A	DIODE		
D109,110	300		1SS131	DIODE		
D111,112			HSS104A	DIODE		
△ D111,112			1SS131	DIODE		
D201-207			HSS104A	DIODE		
D201-207			1SS131	DIODE		
D208			HZS13N(B2)	ZENER DIODE	KPYTE	
D208			MTZJ13(B)	ZENER DIODE	CIMX	
△ D208			RD13ES(B2)	ZENER DIODE	KPYTE	
D208			UZ-13BSB	ZENER DIODE	CIMX	
D209,210			HSS104A	DIODE		
D209,210			1SS131	DIODE		
△ IC1			UPC1237HA	IC(POWER AMP)		
Q1			2SC3940A(R,S)	TRANSISTOR		
Q3, 4			2SC1740S(Q,R)	TRANSISTOR	CIMX	
Q3, 4			2SC2458(Y,GR)	TRANSISTOR	KPYTE	
Q3, 4			2SC2785(F,E)	TRANSISTOR	CIMX	
Q3, 4			2SC3311A(Q,R)	TRANSISTOR	KPYTE	
△ Q5			2SD2012	TRANSISTOR		
Q5			2SD2061	TRANSISTOR		
Q6 -8			2SC1740S(Q,R)	TRANSISTOR	CIMX	
Q6 -8			2SC2458(Y,GR)	TRANSISTOR	KPYTE	
Q6 -8			2SC2785(F,E)	TRANSISTOR	CIMX	
Q6 -8			2SC3311A(Q,R)	TRANSISTOR	KPYTE	
△ Q101,102	100		TRAITR3N	TRANSISTOR	TE	
△ Q101,102	300		TRAITR4N	TRANSISTOR	KPYCIM	
△ Q101,102	100		TRAITR4N	TRANSISTOR	X	
△ Q101,102	100		TRAITR4N	TRANSISTOR		
△ Q103,104	300		TRAITR4N	TRANSISTOR		

L : Scandinavia  
Y : PX(Far East, Hawaii)  
Y : AAFES(Europe)

K : USA  
T : Europe  
X : Australia

P : Canada  
E : Europe  
M : Other Areas

R : Mexico  
G : Germany

I : Malaysia  
C : China

100 : M-A100  
300 : M-A300

△ indicates safety critical components.

\* New Parts  
Parts without **Parts No.** are not supplied.  
Les articles non mentionnés dans le **Parts No.** ne sont pas fournis.  
Teile ohne **Parts No.** werden nicht geliefert.

6

Ref. No	Add-ress	New Parts	Parts No.	Description	Desti-nation	Re-marks
△ Q105,106	100		TRAITR3N	TRANSISTOR	TE	
△ Q105,106	300		TRAITR4N	TRANSISTOR	KPYCIM	
△ Q105,106	100		TRAITR4N	TRANSISTOR	X	
△ Q105,106	100		TRAITR4N	TRANSISTOR	TE	
△ Q107,108	100		TRAITR3P	TRANSISTOR		
△ Q107,108	300		TRAITR4P	TRANSISTOR	KPYCIM	
△ Q107,108	100		TRAITR4P	TRANSISTOR	X	
△ Q107,108	100		TRAITR4P	TRANSISTOR	TE	
△ Q109,110	300		TRAITR4P	TRANSISTOR		
△ Q111,112	100		TRAITR3P	TRANSISTOR		
△ Q111,112	300		TRAITR4P	TRANSISTOR	KPYCIM	
△ Q111,112	100		TRAITR4P	TRANSISTOR	X	
△ Q111,112	100		TRAITR4P	TRANSISTOR	TE	
Q113,114			2SC1845(F,E)	TRANSISTOR		
Q115,116	300		2SC1845(F,E)	TRANSISTOR		
Q117,118			2SC1845(F,E)	TRANSISTOR		
Q201,202			2SC2003(L,K)	TRANSISTOR		
Q203			2SA992(F,E)	TRANSISTOR		
Q204			2SA954(L,K)	TRANSISTOR		
Q205			2SC1740S(Q,R)	TRANSISTOR	CIMX	
Q205			2SC2458(Y,GR)	TRANSISTOR	KPYTE	
Q205			2SC2785(F,E)	TRANSISTOR	CIMX	
Q205			2SC3311A(Q,R)	TRANSISTOR	KPYTE	
Q206			2SC2003(L,K)	TRANSISTOR		
Q207,208	100		2SC1740S(Q,R)	TRANSISTOR	CIMX	
Q207,208	300		2SC2458(Y,GR)	TRANSISTOR	KPYTE	
Q207,208	100		2SC2458(Y,GR)	TRANSISTOR	CIMX	
Q207,208	100		2SC2785(F,E)	TRANSISTOR	KPYTE	
Q207,208	300		2SC3311A(Q,R)	TRANSISTOR	KPYTE	
Q207,208	100		2SC3311A(Q,R)	TRANSISTOR		
Q301-303			2SC1740S(Q,R)	TRANSISTOR	CIMX	
Q301-303			2SC2458(Y,GR)	TRANSISTOR	KPYTE	
Q301-303			2SC2785(F,E)	TRANSISTOR	CIMX	
Q301-303			2SC3311A(Q,R)	TRANSISTOR	KPYTE	
<b>CONTROL (X11-3740-10/X11-3773-00)</b>						
C1, 2			CE04KW1H4R7M	ELECTRO		
C3, 4	300		CE04KW1H4R7M	ELECTRO	4.7UF	50WV
C5, 6			CE04KW1H4R7M	ELECTRO	4.7UF	50WV
C7, 8			CK45FB1H681K	CERAMIC	680PF	K
C9, 10	300		CK45FB1H681K	CERAMIC	680PF	K
C11, 12			CK45FB1H681K	CERAMIC	680PF	K
C25, 26			CE04KW1A101M	ELECTRO	100UF	10WV
C27, 28	300		CE04KW1A101M	ELECTRO	100UF	10WV
C29, 30			CE04KW1A101M	ELECTRO	100UF	10WV
C31, 32			CC45FSL2H680J	CERAMIC	68PF	J
C33, 34	300		CC45FSL2H680J	CERAMIC	68PF	J
C35, 36			CC45FSL2H680J	CERAMIC	68PF	J
C37, 38			CC45FSL2H470J	CERAMIC	47PF	J
C39, 40	300		CC45FSL2H470J	CERAMIC	47PF	J
C41, 42			CC45FSL2H470J	CERAMIC	47PF	J
C43, 44			CE04KW2A470M	ELECTRO	47UF	100WV
C45	100		CK45FF1H103Z	CERAMIC	0.010UF	Z
C46			CE04KW2A221M	ELECTRO	220UF	100WV
C47			CE04KW1E470M	ELECTRO	47UF	25WV
C48			CE04KW1C470M	ELECTRO	47UF	16WV

L : Scandinavia  
Y : PX(Far East, Hawaii)  
Y : AAFES(Europe)

K : USA  
T : Europe  
X : Australia

P : Canada  
E : Europe  
M : Other Areas

R : Mexico  
G : Germany

I : Malaysia  
C : China

100 : M-A100  
300 : M-A300

△ indicates safety critical components.

# M-A100/A300

## PARTS LIST

\* New Parts  
Parts without **Parts No.** are not supplied.  
Les articles non mentionnés dans le **Parts No.** ne sont pas fournis.  
Teile ohne **Parts No.** werden nicht geliefert.

7

Ref. No	Add-ress	New Parts	Parts No.	Description	Desti-nation	Re-marks
C49			CE04KW2A221M	ELECTRO		
C74			CE04KW1E470M	ELECTRO		
C75			CE04KW1C470M	ELECTRO		
C76			C91-1488-05	MF		
C77,78			CK45FF1H103Z	CERAMIC		
C85,86			CK45FB1H681K	CERAMIC		
C87,88	300		CK45FB1H681K	CERAMIC		
C89,90			CK45FB1H681K	CERAMIC		
C103-108			CC45FSL1H221J	CERAMIC	TE	
C109,110			CC45FSL1H101J	CERAMIC	TE	
C111,112			CC45FSL1H101J	CERAMIC	TE	
C113,114			CC45FSL1H101J	CERAMIC		
C117,118			CC45FSL1H220J	CERAMIC		
C119,120			CC45FSL1H220J	CERAMIC		
C127,128			CC45FSL1H330J	CERAMIC		
C129,130			CC45FSL1H330J	CERAMIC		
C131,132			CC45FSL1H330J	CERAMIC		
C203			CE04HW1E220M	NP-ELEC		
CN5			E40-4245-05	PIN ASSY	CIMX	
CN5			E40-8126-05	PIN ASSY	KPYTE	
CN6,7			E40-9825-05	SOCKET FOR PIN ASSY		
CN8			E40-9824-05	SOCKET FOR PIN ASSY		
CN9			E40-9827-05	SOCKET FOR PIN ASSY		
CN12			E40-4293-05	FLAT CABLE CONNECTOR		
CN13			E40-4245-05	PIN ASSY	CX	
CN13			E40-8126-05	PIN ASSY	KPTE	
J1	1C		E58-0018-05	RECTANGULAR RECEPTACLE		
J2	1C		E03-0109-05	AC OUTLET	T	
J2	1C		E03-0305-05	AC OUTLET	EMI	
J2	1C		E03-0316-05	AC OUTLET	KPY	
J2	1C		E03-0325-05	AC OUTLET	X	
J2	1C		E03-0337-05	AC OUTLET	C	
J3	100		E63-0116-05	PHONO JACK	CIMX	
J3	100		E63-0164-05	PHONO JACK	KPYTE	
W27	100		E31-0001-00	JUMPER WIRE		
W52	300		E31-0001-00	JUMPER WIRE		
W81	100		E31-0001-00	JUMPER WIRE		
W82,83	300		E31-0001-00	JUMPER WIRE		
F1	100		F05-2525-05	FUSE (SEMKO)	TE	
F2	100		F05-4025-05	FUSE (SEMKO)	TEYCIM	
F2	100		F05-4025-05	FUSE (SEMKO)	X	
F2	300		F05-6321-05	FUSE (SEMKO)	TECX	
F2	100		F50-0077-05	FUSE(5X20)	KP	
F2	300		F50-0078-05	FUSE(5X20)	KP	
F2,3	300		F05-5025-05	FUSE (SEMKO)	YMI	
F3	100		F05-4025-05	FUSE (SEMKO)	YMI	
P1			F10-0977-14	SHIELDING PLATE	CIMX	
P1			F10-1044-04	SHIELDING PLATE	KPYTE	
CN1,2			J13-0075-05	FUSE CLIP	TE	
CN3,4			J13-0075-05	FUSE CLIP		
CN10,11			J13-0075-05	FUSE CLIP	YMI	
R3,4	300		RD14BB2C473J	RD		
R9,10	300		RD14BB2C133J	RD		
R15,16	300		RD14BB2C272J	RD		

L : Scandinavia  
Y : PX(Far East, Hawaii)  
Y : AAFES(Europe)

K : USA  
T : Europe  
X : Australia  
M : Other Areas

P : Canada  
E : Europe  
M : Other Areas

R : Mexico  
G : Germany  
M : Other Areas

I : Malaysia  
C : China

100 : M-A100  
300 : M-A300

△ indicates safety critical components.

\* New Parts  
Parts without **Parts No.** are not supplied.  
Les articles non mentionnés dans le **Parts No.** ne sont pas fournis.  
Teile ohne **Parts No.** werden nicht geliefert.

8

Ref. No	Add-ress	New Parts	Parts No.	Description	Desti-nation	Re-marks
R21,22	300		RD14BB2C272J	RD		
R27,28	300		RD14BB2C202J	RD		
R29	300		RD14BB2C202J	RD		
R30	100		RD14BB2C152J	RD		
R30	300		RD14BB2C202J	RD		
R31,32			RD14NB2E221J	RD		
R33,34	300		RD14NB2E221J	RD		
R35-38			RD14NB2E221J	RD		
R39,40	300		RD14NB2E221J	RD		
R41,42			RD14NB2E221J	RD		
R43,44			RD14NB2E103J	RD		
R45,46	300		RD14NB2E103J	RD		
R47,48			RD14NB2E103J	RD		
R49,50			RD14NB2E271J	RD		
R51,52	300		RD14NB2E271J	RD		
R53,54			RD14NB2E271J	RD		
R55,56			RD14NB2E220J	RD		
R61,62			RD14NB2E470J	RD		
R69,70	300		RD14NB2C473J	RD		
R75,76	300		RD14BB2C1R0J	RD		
R173	300		RD14BB2C222J	RD		
R179	300		RD14BB2C222J	RD		
R185	300		RD14BB2C104J	RD		
R191,192	300		RD14BB2C470J	RD		
R204			RS14KB3A681J	FL-PROOF RS		
R211			RS14KB3A103J	FL-PROOF RS		
K1	100	**	S76-0071-05	MAGNETIC RELAY	YMI	
K2	1C	**	S76-0028-05	MAGNETIC RELAY		
S1			S62-0001-05	SLIDE SWITCH (VOLTAGE)		
D1,2			HSS104A	DIODE		
D1,2			1SS131	DIODE		
D3,4	300		HSS104A	DIODE		
D3,4	300		1SS131	DIODE		
D5-8			HSS104A	DIODE		
D5-8			1SS131	DIODE		
D9,10	300		HSS104A	DIODE		
D9,10	300		1SS131	DIODE		
D11-13			HSS104A	DIODE		
D11-13			1SS131	DIODE		
D14	100		HSS104A	DIODE		
D14	100		1SS131	DIODE		
D15-18			HZS8.2N(B2)	ZENER DIODE	KPYTE	
D15-18			MTZJ8.2(B)	ZENER DIODE	CIMX	
D15-18			RD8.2ES(B2)	ZENER DIODE	KPYTE	
D15-18			UZ-8.2BSB	ZENER DIODE	CIMX	
D203			HZS3.9N(B2)	ZENER DIODE	KPYTE	
D203			MTZJ3.9(B)	ZENER DIODE	CIMX	
D203			RD3.9ES(B2)	ZENER DIODE	CIMX	
D203			UZ-3.9BSB	ZENER DIODE	CIMX	
D204			HZS15N(B2)	ZENER DIODE	KPYTE	
D204			MTZJ15(B)	ZENER DIODE	CIMX	
D204			RD15ES(B2)	ZENER DIODE	KPYTE	
D204			UZ-15BSB	ZENER DIODE	CIMX	
Q1,2			2SA992(F,E)	TRANSISTOR		

L : Scandinavia  
Y : PX(Far East, Hawaii)  
Y : AAFES(Europe)

K : USA  
T : Europe  
X : Australia  
M : Other Areas

P : Canada  
E : Europe  
M : Other Areas

R : Mexico  
G : Germany  
M : Other Areas

I : Malaysia  
C : China

100 : M-A100  
300 : M-A300

△ indicates safety critical components.

# M-A100/A300

## PARTS LIST

\* New Parts  
 Parts without **Parts No.** are not supplied.  
 Les articles non mentionnes dans le **Parts No.** ne sont pas fournis.  
 Teile ohne **Parts No.** werden nicht geliefert.

Ref. No	Add-ress	New Parts	Parts No.	Description	Desti-nation	Re-marks
Q3 ,4	300		2SA992(F,E)	TRANSISTOR		
Q5 -8			2SA992(F,E)	TRANSISTOR		
Q9 ,10	300		2SA992(F,E)	TRANSISTOR		
Q11 ,12			2SA992(F,E)	TRANSISTOR		
Q13 ,14			2SC2631(R,S)	TRANSISTOR		
Q15 ,16	300		2SC2631(R,S)	TRANSISTOR		
Q17 -20			2SC2631(R,S)	TRANSISTOR		
Q21 ,22	300		2SC2631(R,S)	TRANSISTOR		
Q23 ,24			2SC2631(R,S)	TRANSISTOR		
Q25 ,26			2SA1123(R,S)	TRANSISTOR		
Q27 ,28	300		2SA1123(R,S)	TRANSISTOR		
Q29 ,30			2SA1123(R,S)	TRANSISTOR		
Q31 ,32			2SC3940A(R,S)	TRANSISTOR		
Q31 ,32			2SD863(E,F)	TRANSISTOR		
Q121,122			2SC2878(B)	TRANSISTOR		
Q123	300		2SC2878(B)	TRANSISTOR		
Q124-126			2SC2878(B)	TRANSISTOR		
Q203			2SA1048(Y,GR)	TRANSISTOR	KPYTE	
Q203			2SA1175(F,E)	TRANSISTOR	CIMX	
Q203			2SA1309A(Q,R)	TRANSISTOR	KPYTE	
Q203			2SA933AS(Q,R)	TRANSISTOR	CINX	

L : Scandinavia    K : USA    P : Canada    R : Mexico    I : Malaysia    100 : M-A100  
 Y : PX(Far East, Hawaii)    T : Europe    E : Europe    G : Germany    C : China    300 : M-A300  
 Y : AAFES(Europe)    X : Australia    M : Other Areas

⚠ indicates safety critical components.

