

KMF-X9000/X9000-S MX-5000 SERVICE MANUAL

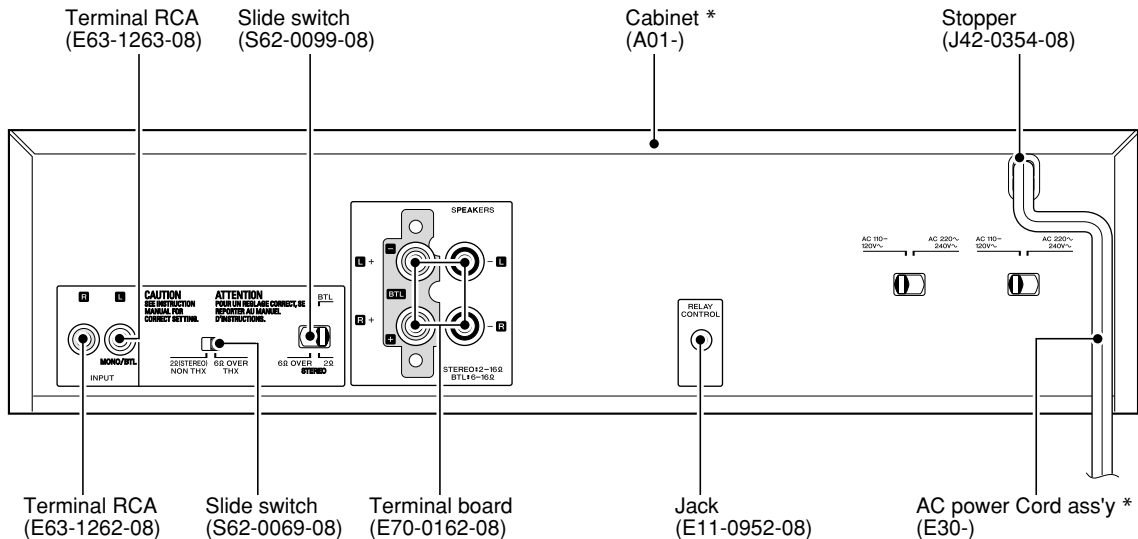

* Refer to parts list on page 10.

Caution : No connection of ground line if disassemble the unit. Please connect the ground line on rear panel, PCBs, Chassis and some others.

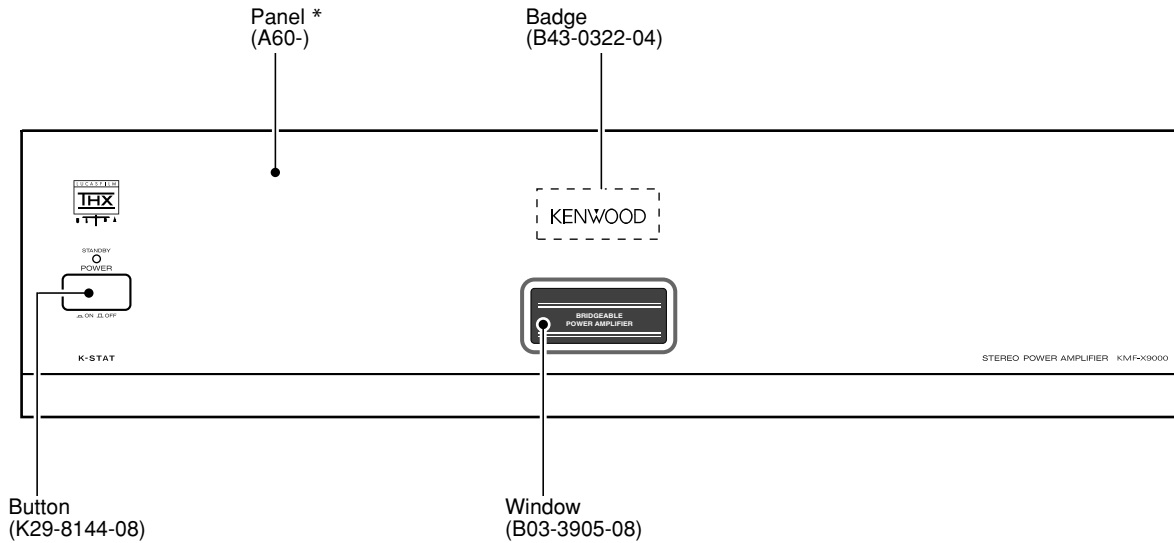

KMF-X9000/MX-5000

CONTENTS / ACCESSORIES

Contents

CONTENTS / ACCESSORIES	2	EXPLODED VIEW	9
ADJUSTMENT	2	PARTS LIST.....	10
PC BOARD	3	SPECIFICATIONS	Back cover
SCHEMATIC DIAGRAM	7		

Accessories

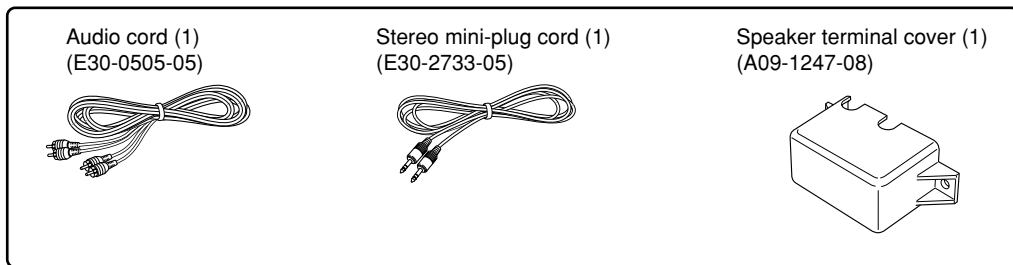

ADJUSTMENT

No.	ITEM	INPUT SETTINGS	OUTPUT SETTINGS	AMPLIFIER SETTINGS	ALIGNMENT POINT	ALIGN FOR	FIG.
Unless otherwise specified, the individual switches should be set as following: POWER: ON							
1	IDLE CURRENT	—	Connect a DC voltmeter between pin 1 and pin 2 of connectors. CN107 (Lch) CN106 (Rch)	No signal input	VR107(L) VR106(R)	20 mV	

PC BOARD(Component side view)

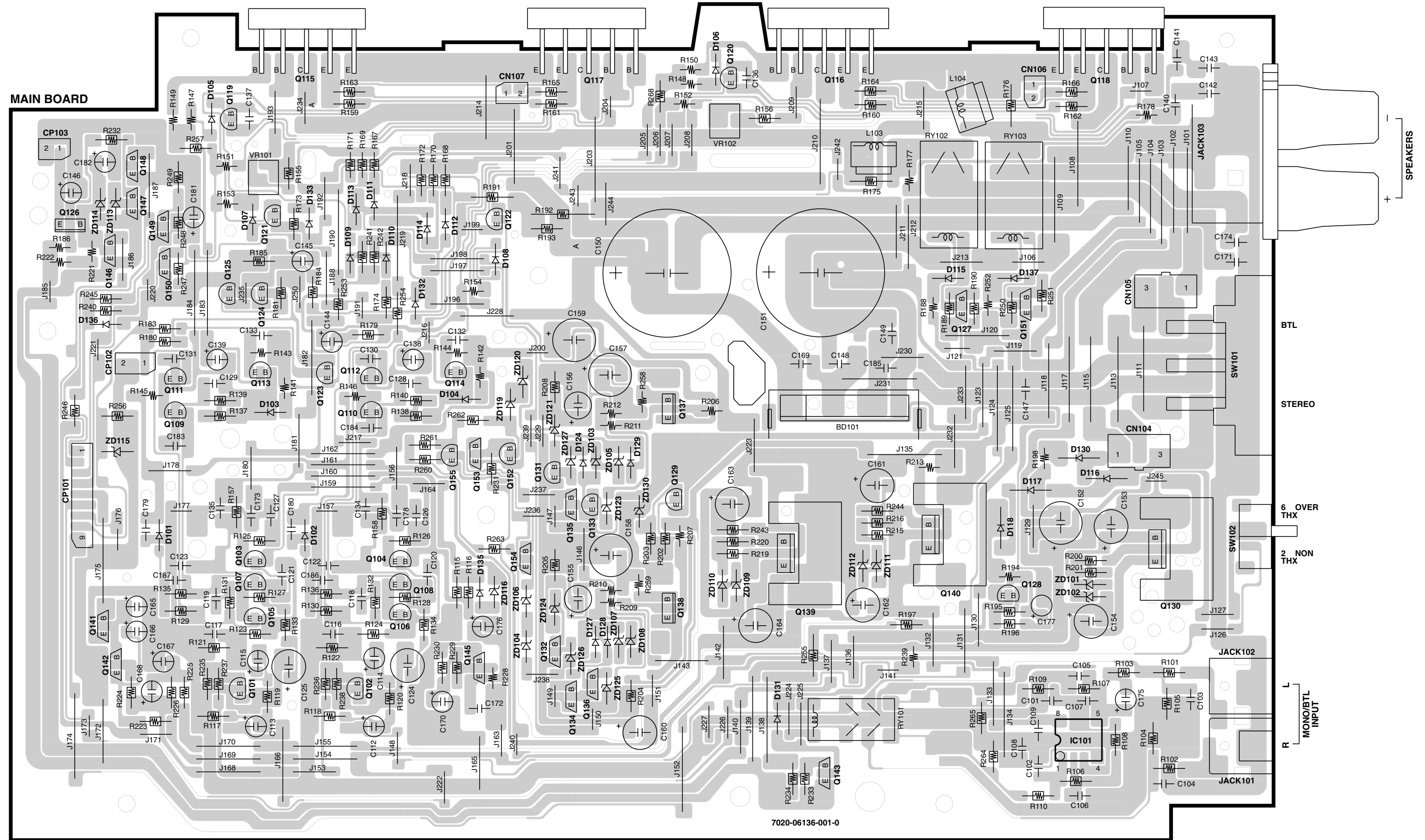

PC BOARD(Component side view)

u-COM BOARD

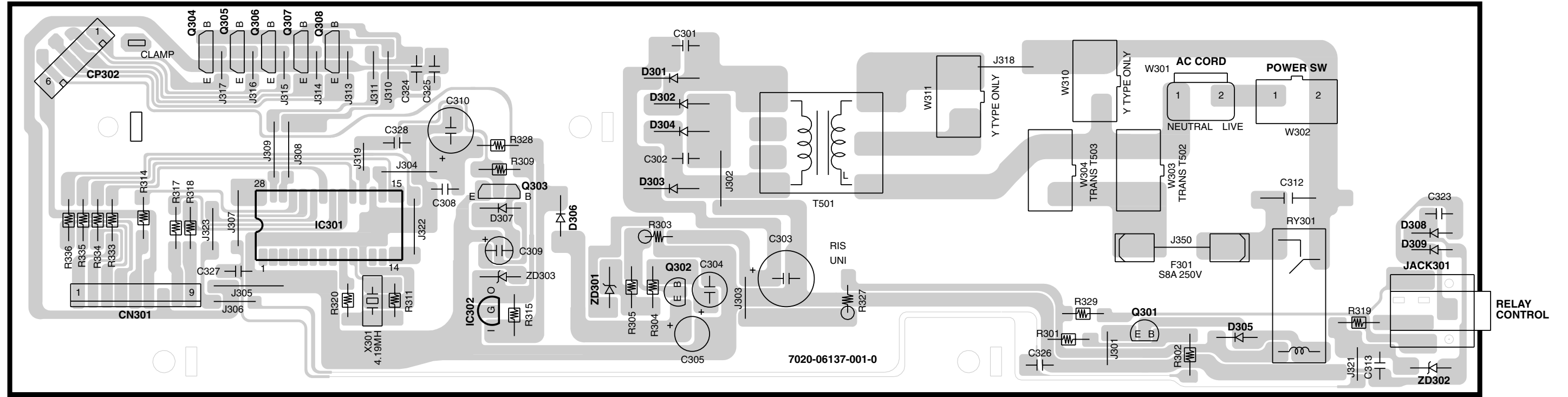

POWER SW BOARD

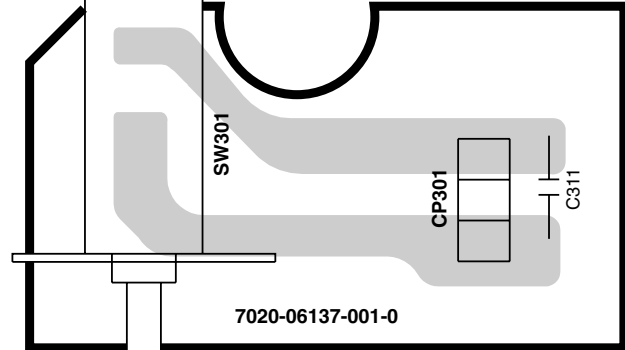

LED BOARD

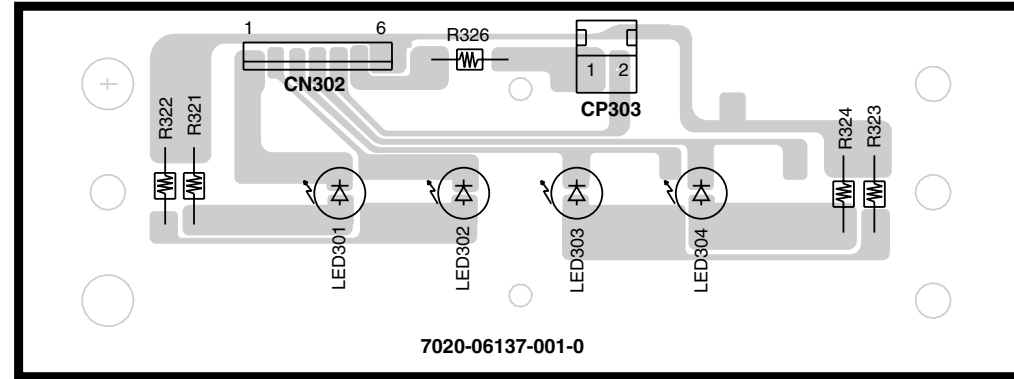

POWER SEL BOARD

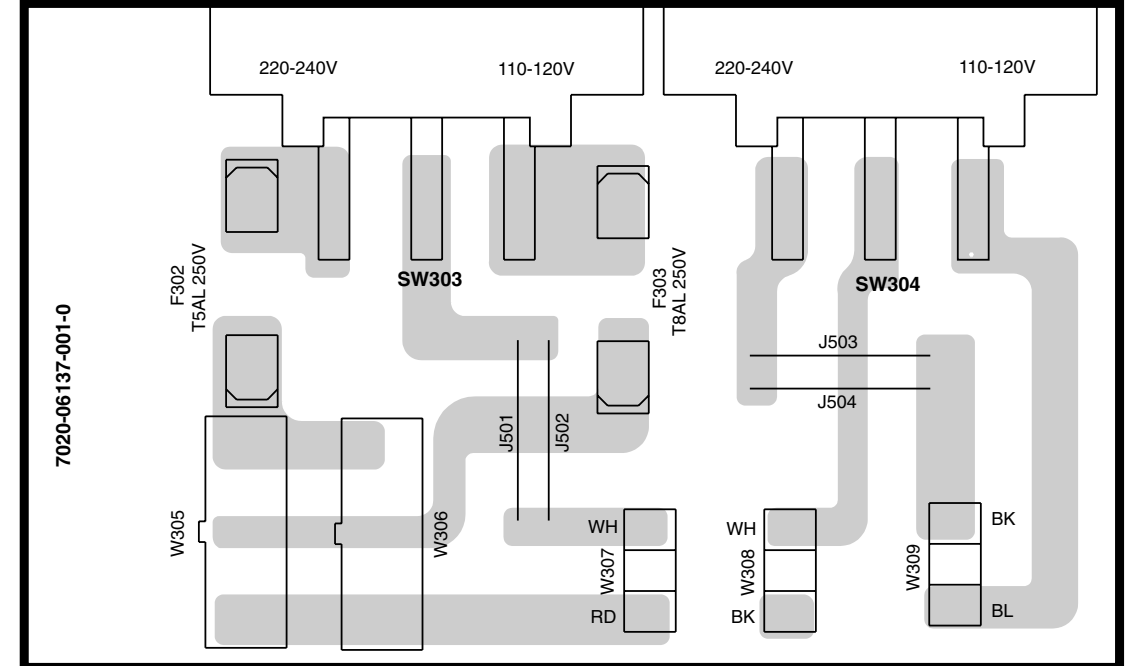

STANDBY BOARD

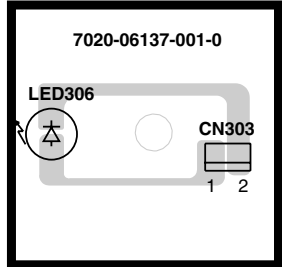

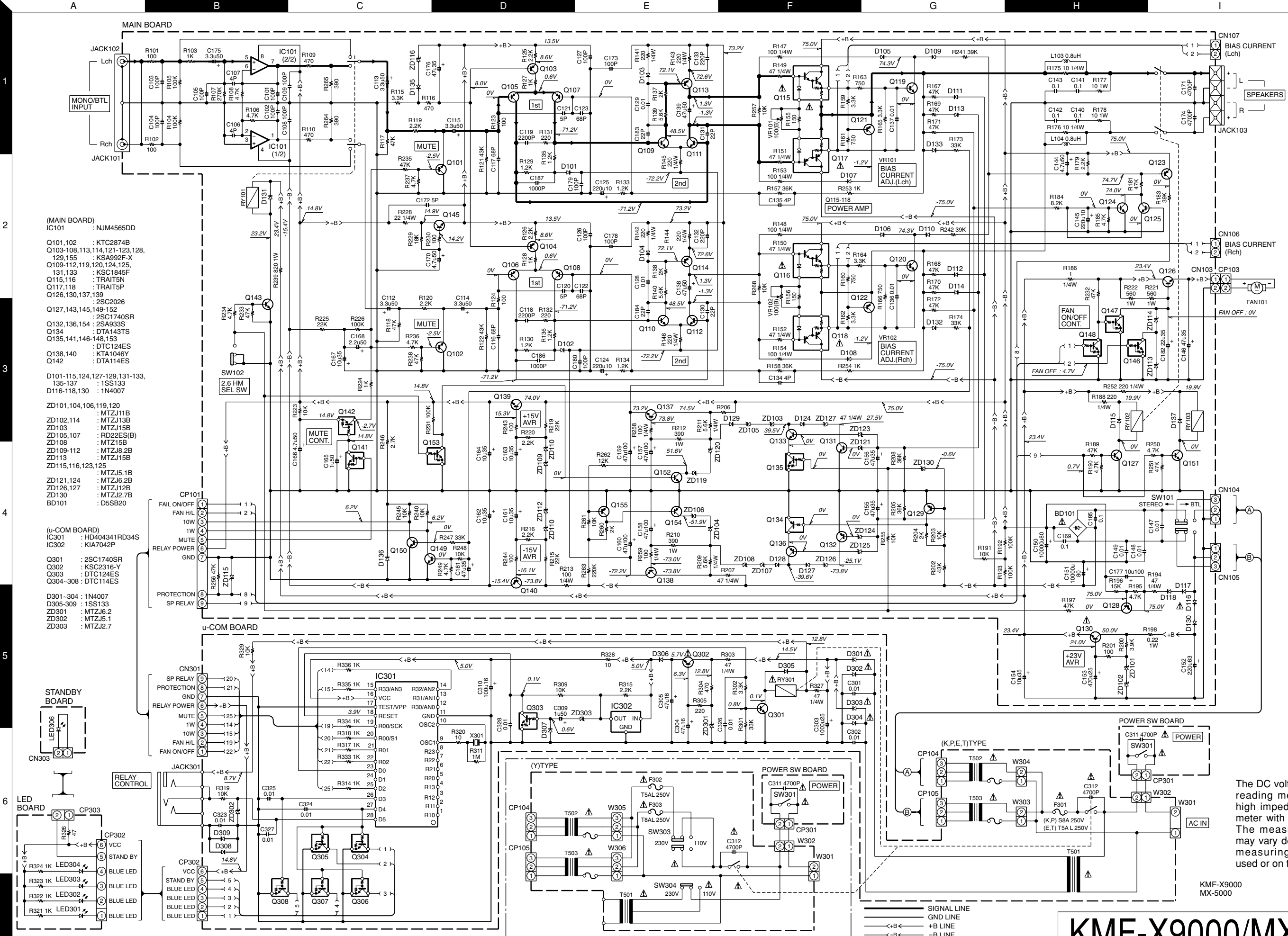

- (MAIN BOARD)
 IC101 : NJM4565DD
 Q101,102 : KTC2874B
 Q103-108,113,114,121-123,128,129,155 : KSA992F-X
 Q109-112,119,120,124,125,131,133 : KSC1845F
 Q115,116 : TRAIT5N
 Q117,118 : TRAIT5P
 Q126,130,137,139 : 2SC2026
 Q127,143,145,149-152 : 2SC1740SR
 Q132,136,154 : 2SA933S
 Q134 : DTA143TS
 Q135,141,146-148,153 : DTC124ES
 Q138,140 : KTA1046Y
 Q142 : DTA114ES
 D101-115,124,127-129,131-133,135-137 : 1SS133
 D116-118,130 : 1N4007
 ZD101,104,106,119,120 : MTZJ11B
 ZD102,114 : MTZJ13B
 ZD103 : MTZJ15B
 ZD105,107 : RD22ES(B)
 ZD108 : MTZ15B
 ZD109-112 : MTZJ8.2B
 ZD113 : MTZJ15B
 ZD115,116,123,125 : MTZJ5.1B
 ZD121,124 : MTZJ6.2B
 ZD126,127 : MTZJ12B
 ZD130 : MTZJ2.7B
 BD101 : DS5B20
- (u-COM BOARD)
 IC301 : HD40431RD34S
 IC302 : KIA7042P
 Q301 : 2SC1740SR
 Q302 : KSC2316-Y
 Q303 : DTC124ES
 Q304-308 : DTC114ES
 D301-304 : 1N4007
 D305-309 : 1SS133
 ZD301 : MTZJ6.2
 ZD302 : MTZJ5.1
 ZD303 : MTZJ2.7

CAUTION: For continued safety, replace safety critical components only with manufacturer's recommended parts (refer to parts list). Δ indicates safety critical components. For continued protection against risk of fire, replace only with same type and rating fuse(s). To reduce the risk of electric shock, leakage-current or resistance measurements shall be carried out (exposed parts are acceptably insulated from the supply circuit) before the appliance is returned to the customer.

The DC voltage is an actual reading measured with a high impedance type voltmeter with no signal input. The measurement value may vary depending on the measuring instruments used or on the product.

KMF-X9000
 MX-5000

KMF-X9000/MX-5000

Y08-5790-10

KENWOOD

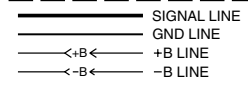

KMF-X9000/MX-5000

EXPLODED VIEW

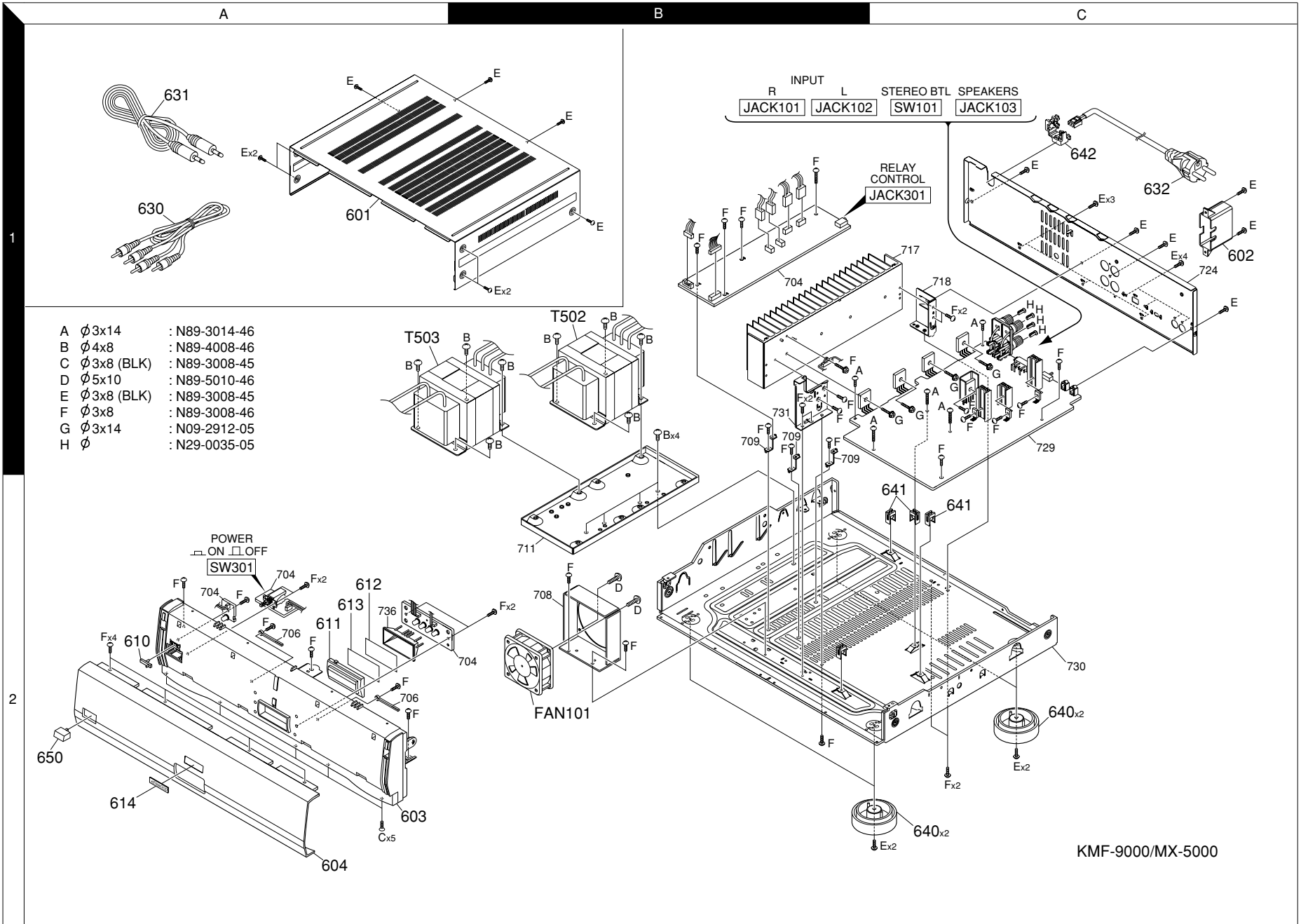

Parts with exploded numbers larger than 700 are not supplied.

* New Parts
Parts without **Parts No.** are not supplied.
Les articles non mentionnés dans le **Parts No.** ne sont pas fournis.
Teile ohne **Parts No.** werden nicht geliefert.

①

Ref. No	Add-ress	New Parts	Parts No.	Description	Desti-nation	Re-marks
KMF-X9000/KMF-9000-S/MX-5000						
601	1A	*	A01-3856-08	CABINET	3000020226060	KEY
601	1A	*	A01-3857-08	CABINET	3000020226070	ES
602	1C	*	A09-1247-08	COVER	4317210311000	ES
603	2A	*	A22-1876-08	PANEL,FRAME	3067210701000	ES
604	2A	*	A60-2210-08	PANEL	3067210711000	K
604	2A	*	A60-2211-08	PANEL	3067210711010	EY
604	2A	*	A60-2212-08	PANEL	3067210711020	ES
610	2A	*	B03-3904-08	LENS	3710210230000	
611	2A	*	B03-3905-08	WINDOW	5070210643000	
612	2A	*	B11-1550-08	FILTER	5200210112000	
613	2A	*	B11-1551-08	FILTER	5207210112000	
614	2A	*	B43-0322-04	BADGE	5637210218000	K
-		*	B60-5097-08	INST.MANUAL(EN)	57072103500A0	EESY
-		*	B60-5098-08	INST.MANUAL(FR)	57072103500B0	EES
-		*	B60-5099-08	INST.MANUAL(GE)	57072103500C0	E
-		*	B60-5100-08	INST.MANUAL(NE)	57072103500E0	EES
-		*	B60-5101-08	INST.MANUAL(IT)	57072103500F0	EES
-		*	B60-5102-08	INST.MANUAL(SP)	57072103500D0	EES
-		*	B60-5163-08	INST.MANUAL(EN)	5707210350080	K
-		*	B60-5164-08	INST.MANUAL(FR)	5707210350090	K
630	1A		E30-0505-05	CORD,RCA	L063210200000	
631	1A		E30-2733-05	CORD,SYNCH	L063210210040	
632	1C		E30-2839-08	CORD ASSY	L068000000100	ES
632	1C	*	E30-7254-08	CORD ASSY	L068000000110	ES
FAN101	2B	*	F09-0170-08	FAN,DC	G720240800010	
-		*	H10-7780-08	CUSHION,SNOW	6230210414000	
-		*	H10-7781-08	CUSHION,SNOW	6230210414000	
-		*	H25-1573-08	POLY BAG	6337000409030	
-		*	H25-1601-08	POLY BAG	6337000240010	
-		*	H25-1726-08	POLY BAG	6330000409020	
-		*	H50-4221-08	BOX,GIFT	6007020370010	K
-		*	H50-4222-08	BOX,GIFT	6007020370040	Y
-		*	H50-4223-08	BOX,GIFT	6007020370020	E
-		*	H50-4224-08	BOX,GIFT	6007020370030	ES
640	2C	*	J02-1539-08	FOOT	4007040201020	
641	2C	*	J19-5725-08	SUPPORTER	4070001601010	
642	1C	*	J42-0354-08	STOPPER	4380000730000	
650	2A	*	K29-8144-08	BUTTON	5090210621000	
T501		*	L07-3171-08	POWER TRANS	8200280004000	EES
T501		*	L07-3172-08	POWER TRANS	8200280960010	K
T501		*	L07-3173-08	POWER TRANS	8200350150020	Y
T502	1B	*	L07-3174-08	POWER TRANS	8200858630120	K
T502	1B	*	L07-3175-08	POWER TRANS	8200858630140	EES
T502	1B	*	L07-3176-08	POWER TRANS	8200858630160	Y
T503	1A	*	L07-3177-08	POWER TRANS	8200858630130	K
T503	1A	*	L07-3178-08	POWER TRANS	8200858630150	EES
T503	1A	*	L07-3179-08	POWER TRANS	8200858630170	Y
ELECTRONIC PARTS						
LED301-304		*	B30-2631-08	LED,ROUND	K500056000010	
LED306		*	B30-2632-08	LED,ROUND	K500052016010	

L : Scandinavia K : USA P : Canada R : Mexico C : China I : Malaysia
Y : PX(Far East,Hawaii) T : England E : Europe G : Germany V : China(Shanghai)
Y : AAFES(Europe) X : Australia Q : Russia H : Korea M : Other Areas Δ indicates safety critical components.

* New Parts
Parts without **Parts No.** are not supplied.
Les articles non mentionnés dans le **Parts No.** ne sont pas fournis.
Teile ohne **Parts No.** werden nicht geliefert.

②

Ref. No	Add-ress	New Parts	Parts No.	Description	Desti-nation	Re-marks
C101-105			CC45FSL1H101J	CERAMIC	100PF	J
C106,107			CC45FCH1H040C	CERAMIC	4.0PF	C
C108,109			CC45FSL1H101J	CERAMIC	100PF	J
C112-115			CE04LW1H3R3M	ELECTRO	3.3UF	50WV
C116,117			CC45FSL1H680J	CERAMIC	68PF	J
C118,119			CK45FB1H222Z	CERAMIC	2200PF	Z
C120,121			CC45FSL1H050C	CERAMIC	5.0PF	C
C122,123			CC45FSL1H680J	CERAMIC	68PF	J
C124,125			CE04LW1A221M	ELECTRO	220UF	10WV
C126,127			CC45FSL1H101J	CERAMIC	100PF	J
C128,129			CK45FB1H103K	CERAMIC	0.010UF	K
C130,131			CC45FCH1H220J	CERAMIC	22PF	J
C132,133			CC45FSL1H221J	CERAMIC	220PF	J
C134,135			CC45FCH1H040C	CERAMIC	4.0PF	C
C136,137			CK45FB1H103K	CERAMIC	0.010UF	K
C138,139			CE04LW1H470M	ELECTRO	47UF	50WV
C140-143			CF92FV1H104K	MF-C	0.10UF	K
C144			CE04LW1H4R7M	ELECTRO	4.7UF	50WV
C145			CE04LW1A221M	ELECTRO	220UF	10WV
C146			CE04LW1V470M	ELECTRO	47UF	35WV
C147-149			CK45FE2H103P	CERAMIC	0.010UF	P
C150,151			C90-5751-08	ELECTRO	10000UF	80WV
C152			CE04LW1J221M	ELECTRO	220UF	63WV
C153			CE04LW1E471M	ELECTRO	470UF	25WV
C154			CE04LW1V100M	ELECTRO	10UF	35WV
C155,156			CE04LW1V470M	ELECTRO	47UF	35WV
C157-160			CE04LW2A470M	ELECTRO	47UF	100WV
C161-164			CE04LW1V100M	ELECTRO	10UF	35WV
C165			CE04LW1H010M	ELECTRO	1.0UF	50WV
C166			CE04LW1H4R7M	ELECTRO	4.7UF	50WV
C167			CE04LW1V100M	ELECTRO	10UF	35WV
C168			CE04LW1H2R2M	ELECTRO	2.2UF	50WV
C169			C91-1646-08	FILM	0.1UF	250V
C170			CE04LW1H4R7M	ELECTRO	4.7UF	50WV
C171			CK45FB1H472K	CERAMIC	4700PF	K
C172			CC45FSL1H050C	CERAMIC	5.0PF	C
C173			CC45FSL1H101J	CERAMIC	100PF	J
C174			CK45FB1H472K	CERAMIC	4700PF	K
C175			CE04LW1H3R3M	ELECTRO	3.3UF	50WV
C176			CE04LW1V470M	ELECTRO	47UF	35WV
C177			CE04LW2A100M	ELECTRO	10UF	100WV
C178-180			CC45FSL1H101J	CERAMIC	100PF	J
C181			CE04LW1V470M	ELECTRO	47UF	35WV
C182			CE04LW1V220M	ELECTRO	22UF	35WV
C183,184			CC45FSL1H220J	CERAMIC	22PF	J
C185			C91-1646-08	FILM	0.1UF	250V
C186,187			CK45FB1H102K	CERAMIC	1000PF	K
C301,302			CK45FE2H103P	CERAMIC	0.010UF	P
C303			CE04LW1E102M	ELECTRO	1000UF	25WV
C304,305			CE04LW1C470M	ELECTRO	47UF	16WV
C308			CK45FB1H103K	CERAMIC	0.010UF	K
C309			CE04LW1H010M	ELECTRO	1.0UF	50WV
C310			CE04LW1C101M	ELECTRO	100UF	16WV
C311,312			C91-1571-08	CERAMIC	0.0047UF	250VAC
C313			CK45FB1H103K	CERAMIC	0.010UF	K

L : Scandinavia K : USA P : Canada R : Mexico C : China I : Malaysia
Y : PX(Far East,Hawaii) T : England E : Europe G : Germany V : China(Shanghai)
Y : AAFES(Europe) X : Australia Q : Russia H : Korea M : Other Areas Δ indicates safety critical components.

* New Parts
Parts without **Parts No.** are not supplied.
Les articles non mentionnés dans le **Parts No.** ne sont pas fournis.
Teile ohne **Parts No.** werden nicht geliefert.

3

Ref. No	Add-ress	New Parts	Parts No.	Description	Desti-nation	Re-marks
C323-328			CK45FB1H103K	CERAMIC 0.010UF K		
JACK101			E63-1262-08	TER,RCA 1P RED G600110930010		
JACK102			E63-1263-08	TER,RCA 1P WHT G600110929010		
JACK103			E70-0162-08	TER,BOARD SPKR G612041087300		
JACK301			E11-0952-08	JACK,D3.5 G401035100020		
Δ F301			F50-0204-08	FUSE (5.2*20) G650502251160	EESY	
Δ F301			F50-0205-08	FUSE (5.2*20) G650802251010	K	
Δ F302			F04-5022-05	FUSE (5.2*20) 5508303035D	Y	
Δ F303			F50-0206-08	FUSE (5.2*20) G650802251020	Y	
L103,104			L39-1625-08	COIL,FILTER-INDD330102000050		
X301			L78-0748-08	RESONATOR,CERAME830419000060		
R141-146			RD14GB2E221J	FL-PROOF RD 220 J 1/4W		
R147,148			RD14GB2E101J	FL-PROOF RD 100 J 1/4W		
R149-152			RD14GB2E470J	FL-PROOF RD 47 J 1/4W		
R153,154			RD14GB2E101J	FL-PROOF RD 100 J 1/4W		
R175 176			RD14GB2E100J	FL-PROOF RD 10 J 1/4W		
R177 178			RS14GB3A100J	FL-PROOF RS 10 J 1W		
R186			RD14GB2E010J	FL-PROOF RD 1 J 1/4W		
R188			RD14GB2E221J	FL-PROOF RD 220 J 1/4W		
R194			RD14GB2E470J	FL-PROOF RD 47 J 1/4W		
R198			RS14KB3AR22J	FL-PROOF RS 0.22 J 1W		
R206,207			RD14GB2E470J	FL-PROOF RD 47 J 1/4W		
R209			RD14GB2E562J	FL-PROOF RD 5.6K J 1/4W		
R210			RS14GB3A391J	FL-PROOF RS 390 J 1W		
R211			RD14GB2E562J	FL-PROOF RD 5.6K J 1/4W		
R212			RS14GB3A391J	FL-PROOF RS 390 J 1W		
R213			RD14GB2E101J	FL-PROOF RD 100 J 1/4W		
R221,222			RS14GB3A561J	FL-PROOF RS 560 J 1W		
R228			RD14GB2E220J	FL-PROOF RD 22 J 1/4W		
R239			RS14GB3A821J	FL-PROOF RS 820 J 1W		
R252			RD14GB2E221J	FL-PROOF RD 220 J 1/4W		
R258,259			RD14GB2E101J	FL-PROOF RD 100 J 1/4W		
R303			RD14GB2E470J	FL-PROOF RD 47 J 1/4W		
R327			RD14GB2E470J	FL-PROOF RD 47 J 1/4W		
VR101,102			R12-0604-05	VR,SEMI CERMET C544101015100		
RY101-3			S76-0113-08	RELAY G680000250010		
Δ RY301			S76-0090-05	RELAY G6800090502010		
SW101			S62-0099-08	SW,SLIDE G060040540010		
SW102			S62-0069-08	SW,SLIDE G060112010010		
Δ SW301			S68-0144-08	SW,PUSH G000005000010		
Δ SW303,304			S90-0150-08	SW,SLIDE G060040540010	Y	
BD101			D5SB20	D,RECTIFIER BRI K047400300010		
D101-115			1SS133	D,SWITCHING K000013300520		
Δ D116-118			1N4007	D,SWITCHING K000400700520		
D124			1SS133	D,SWITCHING K000013300520		
D127-129			1SS133	D,SWITCHING K000013300520		
D130			1N4007	D,SWITCHING K000400700520		
D131-133			1SS133	D,SWITCHING K000013300520		
D135-137			1SS133	D,SWITCHING K000013300520		
Δ D301-304			1N4007	D,SWITCHING K000400700520		
D305-309			1SS133	D,SWITCHING K000013300520		

L : Scandinavia K : USA P : Canada R : Mexico C : China I : Malaysia
Y : PX(Far East,Hawaii) T : England E : Europe G : Germany V : China(Shanghai)
Y : AAFES(Europe) X : Australia Q : Russia H : Korea M : Other Areas Δ indicates safety critical components .

* New Parts
Parts without **Parts No.** are not supplied.
Les articles non mentionnés dans le **Parts No.** ne sont pas fournis.
Teile ohne **Parts No.** werden nicht geliefert.

4

Ref. No	Add-ress	New Parts	Parts No.	Description	Desti-nation	Re-marks
IC101			NJM4565DD	IC,LINEAR OP J121456500010		
IC301			HD404341RD34S	IC,CPU MICRO PR J020404341340		
IC302			KIA7042P	IC,LINEAR-RESET J125704200010		
Q101,102			KTC2874B	SEMI,TR/GE NPN J502287400010		
Q103-108			KSA992F-X	SEMI,TR/GE PNP J5000992F0050		
Q109-112			KSC1845F	SEMI,TR/GE NPN J5021845F0000		
Q113,114			KSA992F-X	SEMI,TR/GE PNP J5000992F0050		
Δ Q115,116			TRAIT5N	SEMI,DARL TR/NP J583050000010		
Δ Q117,118			TRAIT5P	SEMI,DARL TR/PN J581050000010		
Q119,120			KSC1845F	SEMI,TR/GE NPN J5021845F0000		
Q121-123			KSA992F-X	SEMI,TR/GE PNP J5000992F0050		
Q124,125			KSC1845F	SEMI,TR/GE NPN J5021845F0000		
Q126			KTC2026	SEMI,TR/GE NPN J5032026Y0010		
Q127			2SC1740SR	SEMI,TR/GE NPN J5021740S0010		
Q128,129			KSA992F-X	SEMI,TR/GE PNP J5000992F0050		
Δ Q130			KTC2026	SEMI,TR/GE NPN J5032026Y0010		
Q131			KSC1845F	SEMI,TR/GE NPN J5021845F0000		
Q132			2SA933S	SEMI,TR/GE PNP J5000933S0050		
Q133			KSC1845F	SEMI,TR/GE NPN J5021845F0000		
Q134			DTA143TS	SEMI,BRT/PNP RA J6000143T0010		
Q135			DTC124ES	SEMI,BRT/NPN RC J6020124E0010		
Q136			2SA933S	SEMI,TR/GE PNP J5000933S0050		
Q137			KTC2026	SEMI,TR/GE NPN J5032026Y0010		
Q138			KTA1046Y	SEMI,TR/GE PNP J5001046Y0010		
Q139			KTC2026	SEMI,TR/GE NPN J5032026Y0010		
Q140			KTA1046Y	SEMI,TR/GE PNP J5001046Y0010		
Q141			DTC124ES	SEMI,BRT/NPN RC J6020124E0010		
Q142			DTA114ES	SEMI,BRT/PNP RA J6000114E0010		
Q143			2SC1740SR	SEMI,TR/GE NPN J5021740S0010		
Q145			2SC1740SR	SEMI,TR/GE NPN J5021740S0010		
Q146-148			DTC124ES	SEMI,BRT/NPN RC J6020124E0010		
Q149-152			2SC1740SR	SEMI,TR/GE NPN J5021740S0010		
Q153			DTC124ES	SEMI,BRT/NPN RC J6020124E0010		
Q154			2SA933S	SEMI,TR/GE PNP J5000933S0050		
Q155			KSA992F-X	SEMI,TR/GE PNP J5000992F0050		
Q301			2SC1740SR	SEMI,TR/GE NPN J5021740S0010		
Δ Q302			KSC2316-Y	SEMI,TR/GE NPN J5022316Y0020		
Q303			DTC124ES	SEMI,BRT/NPN RC J6020124E0010		
Q304-308			DTC114ES	SEMI,BRT/NPN RC J6020114E0010		
ZD101			MTZJ11B	D,ZENER K06011R044520		
ZD102			MTZJ13B	D,ZENER K06013R044520		
ZD103			MTZJ15B	D,ZENER K06015R044520		
ZD104			MTZJ11B	D,ZENER K06011R044520		
ZD105			RD22ES(B)	D,ZENER K06022R044520		
ZD106			MTZJ11B	D,ZENER K06011R044520		
ZD107			RD22ES(B)	D,ZENER K06022R044520		
ZD108			MTZJ15B	D,ZENER K06015R044520		
ZD109-112			MTZJ8.2B	D,ZENER K06008R244520		
ZD113			MTZJ15B	D,ZENER K06015R044520		
ZD114			MTZJ13B	D,ZENER K06013R044520		
ZD115,116			MTZJ5.1B	D,ZENER K06005R144520		
ZD119,120			MTZJ11B	D,ZENER K06011R044520		
ZD121			MTZJ6.2B	D,ZENER K06006R244520		
ZD123			MTZJ5.1B	D,ZENER K06005R144520		
ZD124			MTZJ6.2B	D,ZENER K06006R244520		

L : Scandinavia K : USA P : Canada R : Mexico C : China I : Malaysia
Y : PX(Far East,Hawaii) T : England E : Europe G : Germany V : China(Shanghai)
Y : AAFES(Europe) X : Australia Q : Russia H : Korea M : Other Areas Δ indicates safety critical components .

KMF-X9000/MX-5000 PARTS LIST

* New Parts

Parts without **Parts No.** are not supplied.

Les articles non mentionnés dans le **Parts No.** ne sont pas fournis.

Teile ohne **Parts No.** werden nicht geliefert.

5

Ref. No	Add-ress	New Parts	Parts No.	Description	Desti-nation	Re-marks
ZD125			MTZJ5.1B	D,ZENER		
ZD126,127			MTZJ12B	D,ZENER		
ZD130			MTZJ2.7B	D,ZENER		
ZD301			MTZJ6.2B	D,ZENER		
ZD302			MTZJ5.1B	D,ZENER		
ZD303			MTZJ2.7B	D,ZENER		

HOW TO READ THE PARTS LIST

ABBREVIATION OF MODEL AND MASS PRODUCTION'S DESTINATIONS

MODEL	ABB.	Australia	Canada	China	England	Europe	Germany	Korea	Malaysia
<i>KMF-X9000</i>	-	-	-	-	-	E	-	-	-
<i>KMF-X9000-S</i>	-	-	-	-	-	ES	-	-	-
<i>MX-5000</i>	-	-	-	-	-	-	-	-	-
MODEL	ABB.	Mexico	PX/AAFES	Russia	Scandinavia	Shanghai	USA	Other area	
<i>KMF-X9000</i>	-	-	Y	-	-	-	-	-	
<i>KMF-X9000-S</i>	-	-	-	-	-	-	-	-	
<i>MX-5000</i>	-	-	-	-	-	-	K	-	

L : Scandinavia

K : USA

P : Canada

R : Mexico

C : China

I : Malaysia

Y : PX(Far East,Hawaii)

T : England

E : Europe

G : Germany

V : China(Shanghai)

Y : AAFES(Europe)

X : Australia

Q : Russia

H : Korea

M : Other Areas Δ indicates safety critical components .

KMF-X9000/MX-5000 PARTS LIST

KMF-X9000/MX-5000

SPECIFICATIONS

Power amplifier section

Rated power output

● For other countries

STEREO MODE

130 watts per channel minimum RMS, both channels driven at 6 Ω, from 20 Hz to 20,000 Hz with no more than 0.02 % total harmonic distortion (FTC)

MONO (BTL) MODE

270 watts minimum RMS, at 6 Ω, from 20 Hz to 20,000 Hz with no more than 0.03 % total harmonic distortion (FTC)

Frequency response

MAIN IN 5 Hz ~ 100 kHz, +0 dB, -3 dB

Signal to noise ratio

(IHF'66)

MAIN IN 115 dB

Input sensitivity / Impedance

STEREO MODE

MAIN IN 1.1 V / 20 kΩ

MONO (BTL) MODE

MAIN IN 1.5 V / 100 kΩ

● For Europe

(IEC)

STEREO MODE

From 20 Hz to 20,000 Hz, 0.7 % T.H.D. at 6 Ω
..... 130 W+ 130 W

MONO (BTL) MODE

From 20 Hz to 20,000 Hz, 0.7 % T.H.D. at 6 Ω
..... 270 W

(DIN)

STEREO MODE

1 kHz, 0.7 % T.H.D. at 6 Ω145 W + 145 W

MONO (BTL) MODE

1 kHz, 0.7 % T.H.D. at 6 Ω285 W

Total harmonic distortion

STEREO MODE

..... 0.02 % (20 Hz ~ 20 kHz, 130 W, 6 Ω)

..... 0.0018 % (1 kHz, 130 W, 6 Ω)

..... 0.05 % (1 kHz, 50 W, 2 Ω)

MONO (BTL) MODE

..... 0.03 % (20 Hz ~ 20 kHz, 270 W, 6 Ω)

..... 0.0018 % (1 kHz, 270 W, 6 Ω)

General

Power consumption 3.5 A

..... 320 W

..... Less than 2 W (Standby)

Dimensions

W: 440 mm (17-5/16")

H: 128 mm (5-1/32")

D: 385 mm (15-5/32")

Weight (net) 12.3 kg (27.2 lb)



KENWOOD follows a policy of continuous advancements in development. For this reason specifications may be changed without notice.

Manufactured under license from Lucasfilm Ltd. Lucasfilm and THX are trademarks or registered trademarks of Lucasfilm Ltd.

KENWOOD CORPORATION

14-6, Dogenzaka 1-chome, Shibuya-ku, Tokyo, 150-8501 Japan

KENWOOD SERVICE CORPORATION

P.O. BOX 22745, 2201 East Dominguez St., Long Beach, CA 90801-5745, U.S.A.

KENWOOD ELECTRONICS CANADA INC.

6070 Kestrel Road, Mississauga, Ontario, Canada L5T 1S8

KENWOOD ELECTRONICS LATIN AMERICA S.A.

P.O. BOX 55-2791, Piso 6 plaza Chase, Cl. 47 y Aquilino de la Guardia Panama, Republic de Panama

KENWOOD ELECTRONICS BRASIL LTDA.

Alameda Ministro Rocha Azevedo No. 456, Edifício Jaú, 10o Andar, Cerqueira César, Cep 0140-001, São Paulo-SP-Brasil

KENWOOD ELECTRONICS U.K. LIMITED

KENWOOD House, Dwight Road, Watford, Herts., WD1 8EB., United Kingdom

KENWOOD ELECTRONICS BELGIUM N.V.

Leuvensesteenweg 248 J, 1800 Vilvoorde, Belgium

KENWOOD ELECTRONICS DEUTSCHLAND GMBH

Rembrücker Str. 15, 63150 Heusenstamm, Germany

KENWOOD ELECTRONICS FRANCE S.A.

13 Boulevard Ney, 75018 Paris, France

KENWOOD ELECTRONICS ITALIA S.p.A.

Via G. Sirtori, 7/9 20129, Milano, Italy

KENWOOD IBÉRICA S.A.

Bolivia, 239-08020 Barcelona, Spain

KENWOOD ELECTRONICS AUSTRALIA PTY. LTD.

(A.C.N. 001 499 074)
16 Giffnock Avenue, North Ryde, N.S.W. 2113, Australia

KENWOOD ELECTRONICS (HONG KONG) LTD.

Unit 3712-3724, Level 37, Tower 1, Metroplaza, 223 Hing Fong Road, Kwai Fong N.T., Hong Kong

KENWOOD ELECTRONICS GULF FZE

P.O. Box 61318, Jebel Ali, Dubai, U.A.E.

KENWOOD ELECTRONICS SINGAPORE PTE LTD.

No. 1 Genting Lane #02-02, KENWOOD Building, Singapore, 349544

KENWOOD ELECTRONICS (MALAYSIA) SDN BHD.

#4.01 Level 4, Wisma Academy Lot 4A, Jalan 19/1 46300 Petaling Jaya Selangor Darul Ehsan Malaysia

KENWOOD ELECTRONICS (THAILAND) CO., LTD.

2019 New Pechburi Road, Bangkapi, Huaykwang, Bangkok, 10320 Thailand