

# RD-VH7

## SERVICE MANUAL

(VH-600/700)

© 1999-6/B51-5551-00 (K/K) 3133

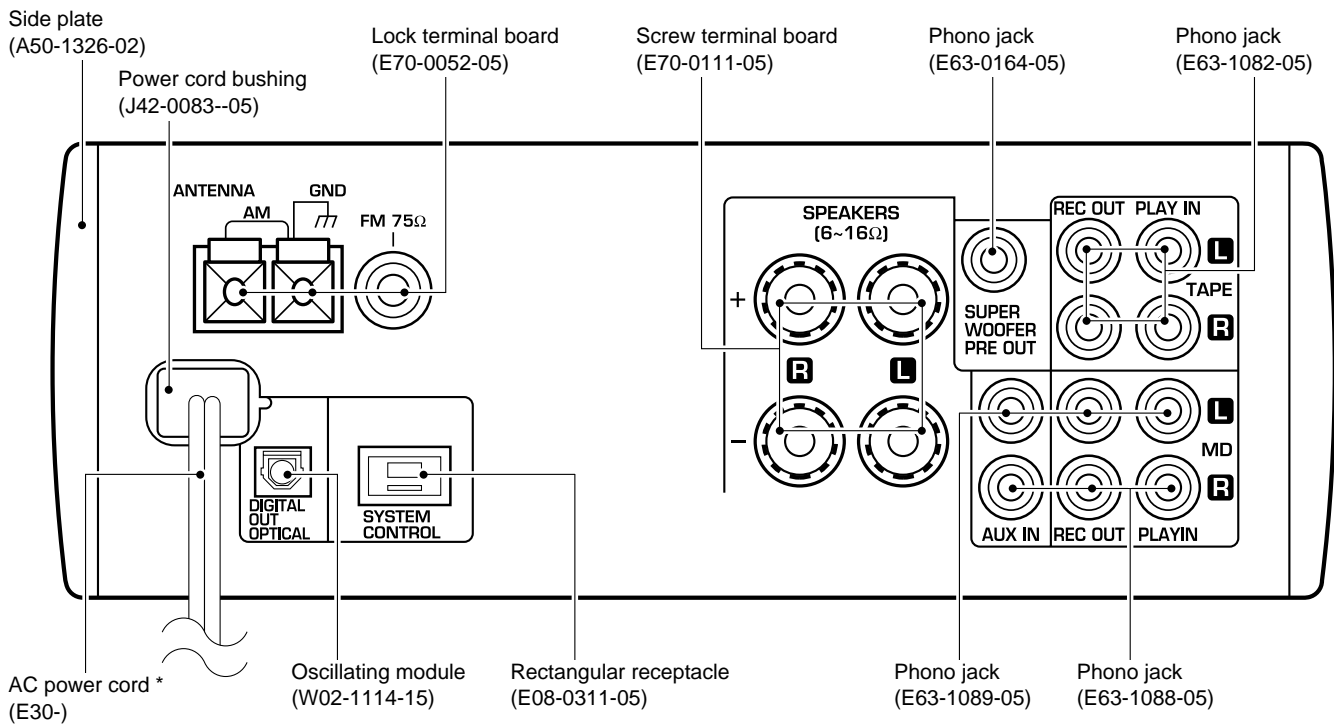
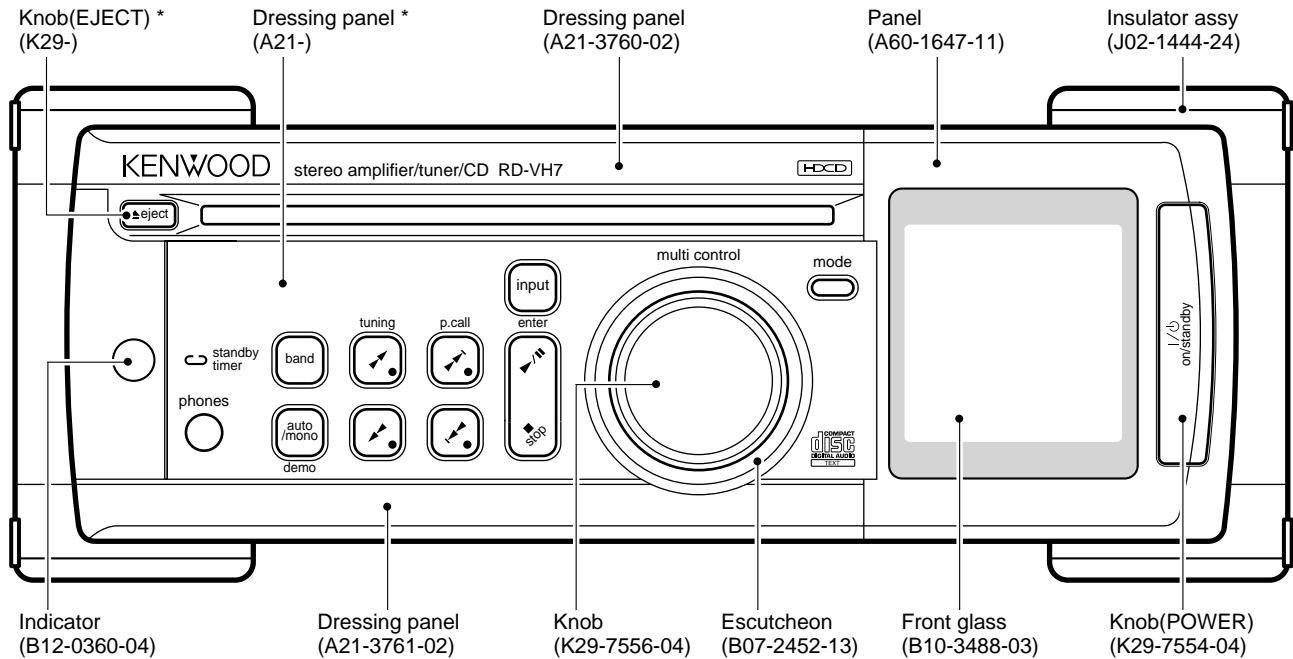

**\*Refer to parts list on page 31.**

In compliance with Federal Regulations, following are reproductions of labels on, or inside the product relating to laser product safety.

KENWOOD-Corp. certifies this equipment conforms to DHHS Regulations No. 21 CFR 1040. 10, Chapter 1, Subchapter J.  
**DANGER : Laser radiation when open and interlock defeated. AVOID DIRECT EXPOSURE TO BEAM.**





# RD-VH7

## CONTENTS / ACCESSORIES

### Contents

CONTENTS / ACCESSORIES .....	2	PARTS DESCRIPTIONS .....	15
DISASSEMBLY FOR REPAIR .....	3	PC BOARD .....	16
BLOCK DIAGRAM .....	4	SCHEMATIC DIAGRAM .....	19
CIRCUIT DESCRIPTION .....	5	EXPLODED VIEW .....	29
CD MECHANISM DESCRIPTION .....	11	PARTS LIST .....	31
ADJUSTMENT .....	14	SPECIFICATIONS .....	Back cover

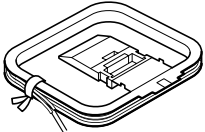
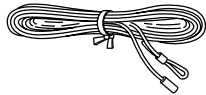
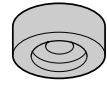
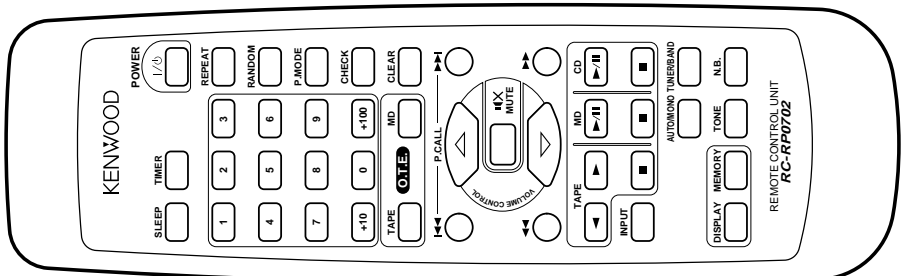
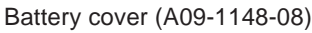
### Accessories

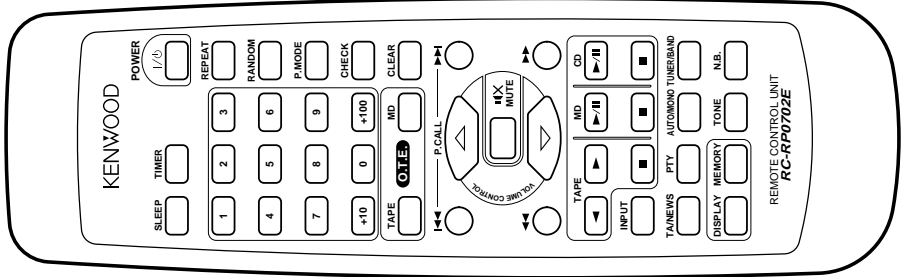
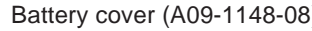
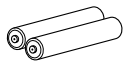
<p>AM loop antenna (1) (T90-0842-05)</p> 	<p>FM indoor antenna (1) (T90-0841-05)</p> 	<p>Replacement front feet (2) (J02-0130-05)</p> 
<p>Remote control unit (1) (A70-1282-05) : RC-RP0702</p> 	<p>Battery cover (A09-1148-08)</p> 	<p>Front feet replacement tool (Allen wrench) (1) (W01-0084-05)</p> 
<p>Remote control unit (1) (A70-1283-05) : RC-RP0702E</p> 	<p>Battery cover (A09-1148-08)</p> 	<p>Batteries (R6/AA) (2)</p> 

### System configuration

SYSTEM NAME	CD RECEIVER	CASSETTE DECK	SPEAKER
VH-600	RD-VH7	-	LS-VH7
VH-700	RD-VH7	X-VH7	LS-VH7

### Operation to reset

The microcomputer may fall into malfunction (impossibility to operate, erroneous display, etc.) when the power cord is unplugged while power is ON or due to an external factor. In this case, execute the following procedure to reset the microcomputer and return it to normal condition.

- Please note that resetting the microcomputer clears the contents stored in it returns it to condition when it left the factory.

#### RD-VH7

**Unplug the power cord from the wall AC outlet and, while holding the “■ stop” key depressed, plug the power cord again.**

- If a CD has been loaded in the unit, it will be ejected automatically.

## DISASSEMBLY FOR REPAIR

### REMOVE CD MECHANISM

After remove insulator ass'y, then remove some LR side board.  
Next remove the top and the bottom boards.

- 1) Remove the 6 screws ①, then remove the front panel.
- 2) Remove the 6 screws ② ③, then remove the CD mechanism.  
When assemble the front panel, insert the phone jack with taking care ④.

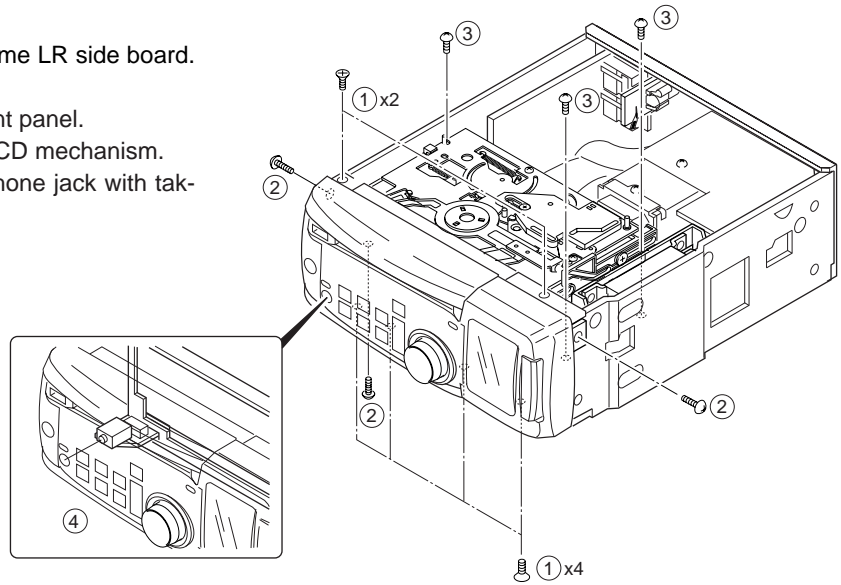

### ELECTRIC CHECK

After assemble the sub panel and the front panel.

- 1) Remove the 8 screws ⑤, ⑥, then remove PCB(X09:B/4), PCB(X14:A/6).
- 2) Remove the 2 screws ⑦, the 3 PC supports ⑧, then remove the CD mechanism.
- 3) After assemble PCB (X09:B/4) on the main PCB with the rear panel. then connect GND between the rear panel , the antenna and the CD mechanism with 3 alligator clip wires ⑩).
- ★ Remove the MULTI CONTROL knob with a string(wires etc) ⑪).

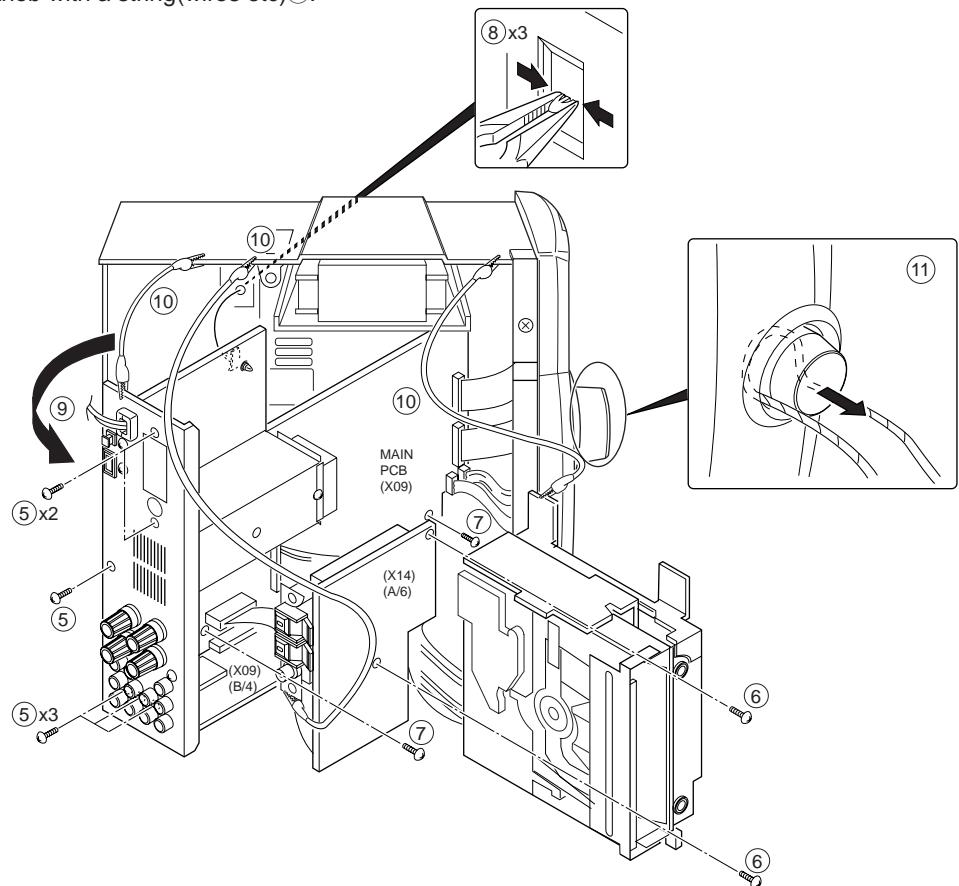

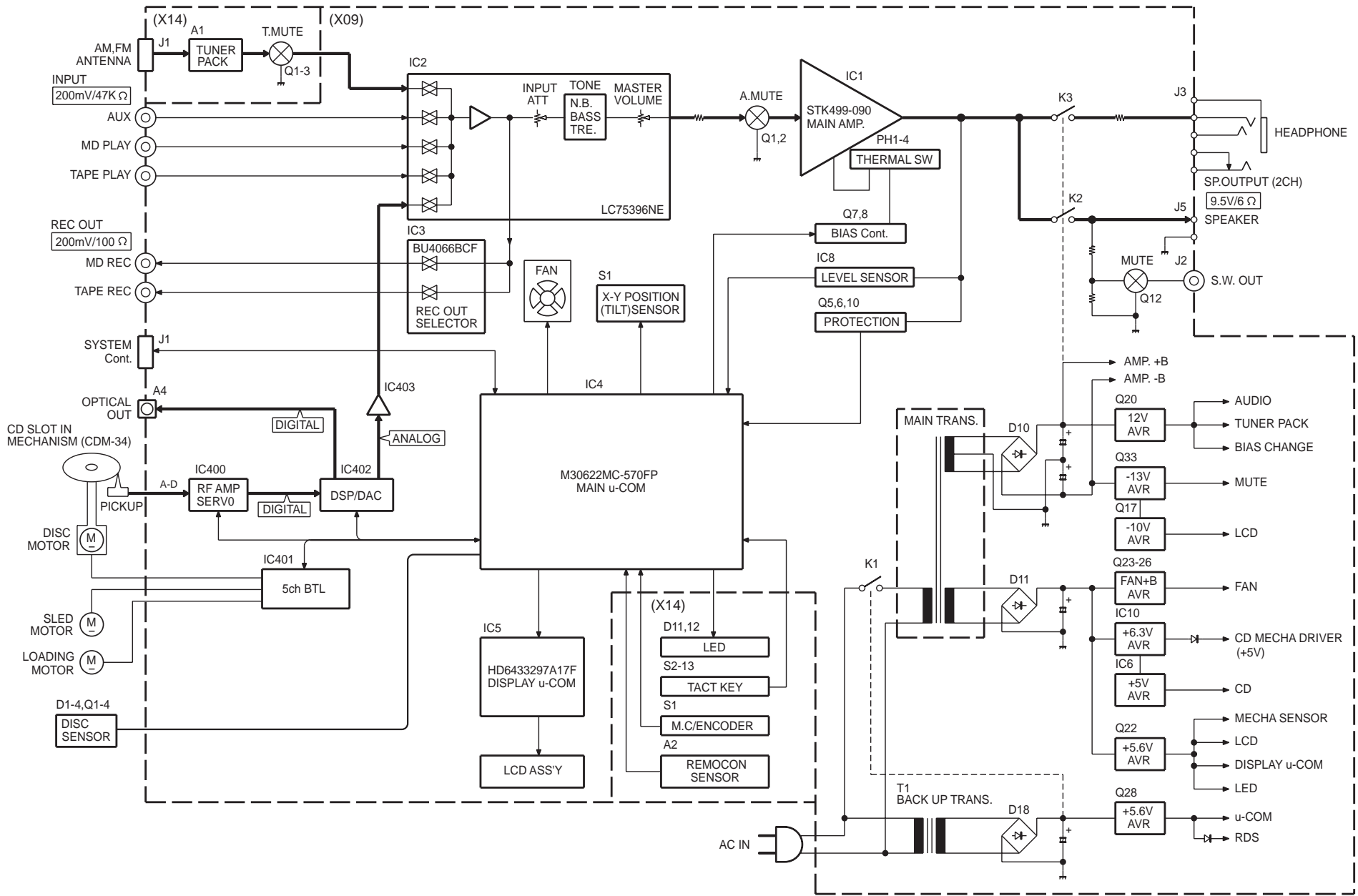

BLOCK DIAGRAM

## CIRCUIT DESCRIPTION

## 1. INITIAL SETTING

## 1-1 INITIAL CONDITIONS

(1) AMP	
POWER	OFF
PROTECTION	NO DETECTED
MUTE	OFF
SELECTOR	TUNER
VOLUME	15
BALANCE	CENTER
NB	2
BASS	0
TREBLE	0
MD INPUT	0 (-6dB)
TAPE INPUT	0 (-6dB)
AUX INPUT	0 (-6dB)
MULTI WINDOW	AUTO
(2) TUNER	
BAND	FM
Pch MEMORY	REFER TO (5)
LAST Pch	--
LAST FREQ.	LOWER LIMIT VALUE OF EACH BANDS
AUTO/MONO	AUTO
AUTO PRESET (MEMORY)	-
E ON THRUST RECEIVING MODE	OFF
RDS DISPLAY	PS
(3) CLOCK, TIMER	
CLOCK	STOP, AM 12:00
PROG. 1,2	
ON TIME	AM12:00
OFF TIME	AM12:00
PLAY MODE	PLAY
SOURCE	TUNER
Pch	01ch
REC MODE	TAPE
O. T. T.	OFF (AM7:00)
TIMER OPERATION MODE	OF F
SLEEP TIMER	OFF(5)
A. P. S.	OFF
(4) CD	
PLAY MODE	TRACK
REPEAT	OFF
RANDOM	OFF
OPERATION MODE	STOP
TIME DISPLAY	SINGLE TIME

## (5) TUNER PRESET FREQUENCY

ch	TUNER DESTINATION					
	E1		K1		E3	
1	FM	97.5MHz	FM	97.5MHz	FM	97.5MHz
2	FM	87.5MHz	FM	87.5MHz	FM	87.5MHz
3	FM	89.1MHz	FM	89.1MHz	FM	89.1MHz
4	FM	108.0MHz	FM	108.0MHz	FM	108.0MHz
5	FM	90.0MHz	FM	90.0MHz	FM	90.0MHz
6	FM	87.5MHz	FM	87.5MHz	FM	87.5MHz
7	FM	87.5MHz	FM	87.5MHz	FM	87.5MHz
8	FM	87.5MHz	AM	1610KHz	FM	87.5MHz
9	AM	1602KHz	AM	1700KHz	AM	1602KHz
10	AM	999KHz	AM	1000KHz	AM	999KHz
11	AM	630KHz	AM	630KHz	AM	630KHz
12	AM	1440KHz	AM	1440KHz	AM	1440KHz
13	FM	106.0MHz	FM	106.0MHz	FM	106.0MHz
14	AM	531KHz	AM	530KHz	AM	531KHz
15	FM	87.5MHz	FM	87.5MHz	FM	87.5MHz
16	FM	98.0MHz	FM	98.0MHz	FM	98.0MHz
17	FM	98.5MHz	FM	98.5MHz	FM	98.5MHz
18	FM	87.5MHz	FM	87.5MHz	FM	87.5MHz
19	AM	990KHz	AM	990KHz	AM	990KHz
20	FM	97.7MHz	FM	97.4MHz	FM	97.7MHz
21	AM	531KHz	AM	530KHz	AM	531KHz
22	FM	87.5MHz	FM	87.5MHz	FM	87.5MHz
23	FM	87.5MHz	FM	87.5MHz	FM	87.5MHz
24	FM	87.5MHz	FM	87.5MHz	FM	87.5MHz
25	FM	87.5MHz	FM	87.5MHz	FM	87.5MHz
26	FM	87.5MHz	FM	87.5MHz	FM	87.5MHz
27	FM	87.5MHz	FM	87.5MHz	FM	87.5MHz
28	FM	87.5MHz	FM	87.5MHz	FM	87.5MHz
29	FM	87.5MHz	FM	87.5MHz	FM	87.5MHz
30	FM	106.0MHz	FM	106.0MHz	FM	106.0MHz
31	FM	87.5MHz	FM	87.5MHz	FM	87.5MHz
32	FM	87.5MHz	FM	87.5MHz	FM	87.5MHz
33	FM	87.5MHz	FM	87.5MHz	FM	87.5MHz
34	FM	87.5MHz	FM	87.5MHz	FM	87.5MHz
35	FM	87.5MHz	FM	87.5MHz	FM	87.5MHz
36	FM	87.5MHz	FM	87.5MHz	FM	87.5MHz
37	FM	87.5MHz	FM	87.5MHz	FM	87.5MHz
38	FM	87.5MHz	FM	87.5MHz	FM	87.5MHz
39	FM	108.0MHz	FM	108.0MHz	FM	108.0MHz
40	AM	999KHz	AM	1000KHz	AM	999KHz

## 2. BACKED UP ITEMS

AC POWER OFF	
(1) AMP	
POWER	BACK UP
PROTECTION	CANCELLED
MUTE	OFF
SELECTOR	BACK UP
VOLUME	BACK UP
BALANCE	BACK UP

## CIRCUIT DESCRIPTION

NB	2
BASS	BACK UP
TREBLE	BACK UP
MD INPUT	BACK UP
TAPE INPUT	BACK UP
AUX INPUT	BACK UP
MULTI WINDOW	BACK UP
 (2) TUNER	
BAND	BACK UP
Pch MEMORY	BACK UP
LAST Pch	BACK UP
LAST FREQ.	BACK UP
AUTO/MONO	BACK UP
AUTO PRESET (MEMORY)	BACK UP
E ON THRUST RECEIVING MODE	BACK UP
RDS DISPLAY	PS
 (3) CLOCK, TIMER	
CLOCK	POWER FAILURE MODE
PROG. 1, 2	
ON TIME	BACK UP
OFF TIME	BACK UP
PLAY MODE	BACK UP
SOURCE	BACK UP
Pch	BACK UP
REC MODE	BACK UP
O. T. T.	BACK UP
TIMER OPERATION MODE	BACK UP
SLEEP TIMER	OFF
A. P. S.	BACK UP
 (4) CD	
PLAY MODE	TRACK
REPEAT	OFF
RANDOM	OFF
OPERATION MODE	STOP
TIME DISPLAY	SINGLE TIME

### 3. CONDITIONS ACCORDING TO THE DESTINATION

( ) SIGNIFIES PIN NUMBER OF u-COM(X09, IC4)

DESTI-NATION	u-COM DESTI-NATION	DSW			BAND	RECEIVING FREQUENCY RANGE	CHANNEL SPACE	IF	RF
		2 (72PIN)	1 (71PIN)	0 (70PIN)					
J	J	0	1	0	FM	76.0MHz~ 87.5MHz	100kHz	-10.7MHz	25kHz
					AM	87.5MHz~108.0MHz	50kHz	-10.7MHz	25kHz
K,P	K1	0	0	0	FM	531kHz~1629kHz	9kHz	+450kHz	9kHz
					FM	87.5MHz~108.0MHz	100kHz	+10.7MHz	25kHz
M	E1	0	0	1	AM	530kHz~1700kHz	10kHz	+450kHz	10kHz
					FM	87.5MHz~108.0MHz	50kHz	+10.7MHz	25kHz
E,T	E3 RDS	1	1	0	AM	531kHz~1602kHz	9kHz	+450kHz	9kHz
					FM	87.5MHz~108.0MHz	50kHz	+10.7MHz	25kHz

### 4. LCD INDICATION

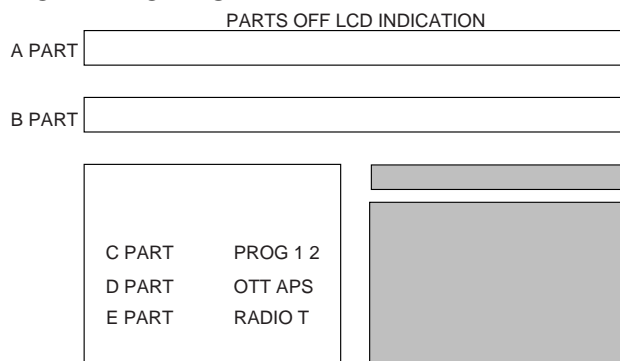

### 5. How to Set the Test Modes

#### 5-1 AUX(MD/TAPE/AUX)

Setting: Insert the power cord to the wall outlet with pressing the MODE key.

Cancel: Press any key of operation.

A part A of display shows destination(\*).

"standby" LED lights orange and green color alternately in this test mode.

A part E of display shows as follows after selecting MD mode.

selector	display E	display A	
MD	MD##TEST	*-TYPE####	#=space
TAPE	TAP#TEST	*-TYPE####	
AUX	AUX#TEST	*-TYPE####	

#### 5-1-1 Display Contrast Setting

Display contrast is available in LED and all segments of display lighting

Contrast is set to initialization if cancel test mode.

key	remarks
FF	contrast min.
skip up	initialization
play/pause	contrast max.

#### 5-1-2 Mute Setting

Muting function is available by pressing AUTO/MONO key.

#### 5-1-3 AUX IN Level Setting

Select the level of aux input from +3, 0, or -6 by pressing the FB key.

Multi control knob is available for same setting after mode key is pressed.

#### 5-1-4 Noise Blanker Setting

Select the level of NB from NB1,NB2 or NB OFF by pressing the SKIP DOWN key.

#### 5-1-5 BASS/TREBLE setting

Select the level of tone from tone max, tone flat or tone min by pressing the BAND key.

Display shows as follows.

	display A	display B	bass value	treble value
tone max.	BASS/TER##	#####MAX	+8	+8
tone min.	BASS/TER##	#####MIN	-8	-8
tone flat	BASS/TER##	####CENTER	0	0

Multi control knob is available for same setting after mode key is pressed.

## CIRCUIT DESCRIPTION

### 5-1-6 Balance Setting

Select the level of balance from L-ch, max, R-ch max or center by pressing the MODE key.

Multi control knob is available for same setting after mode key is pressed.

### 5-2 TUNER

Setting: Insert the power cord to the wall outlet with pressing the BAND key.

Cancel: Press any key of operation.

A part E of display shows RADIO T.

"standby" LED lights orange and green color alternately in this test mode.

#### 5-2-1 Dimmer Setting

Dimmer is available in LED and all segments of display lighting

Select the on/off of dimmer from dimmer on or dimmer off by pressing the CD/PLAY/PAUSE key.

Dimmer is set to OFF if cancel test mode.

#### 5-2-2 P.CALL Setting

Select the step of p.call from 10,20, --- 40 or 01(10steps) by pressing the MODE key.

#### 5-2-3 P. CALL Up/Down Setting

This setting is available by P.CALL UP/DOWN key.

#### 5-2-4 Normal Mode (AUX/TUNER)

This setting is available by pressing MODE key for 1.5 secs .

CD eject works except tuner mode.

### 5-3 Sub Clock Oscillation Check

Setting: Insert the power cord to the wall outlet with pressing the INPUT key.

Cancel: Press any key of operation. However continue tuner test mode.

Display lights if oscillation and period are ok. Display shows ERR1(oscillation) or ERR2(period) and stop to check after 5 time checks.

### 5-4 CD

Setting: Insert the power cord to the wall outlet with pressing the PLAY key.

Cancel: Press any key of operation. However a part B of display is only cancel.

A part A of display shows mechanism sensors. Disc loading sensor/8cm sensor/12cm sensor/down switch in order. Display shows "-" at first time.

A part B of display shows CD-TEST LED is blanking.

#### 5-4-1 Mechanism Sensor Check

Display shows from "-" to "0" or "x" after loading the disc. "0" means sensor works.

"x" not works.

#### 5-4-2 Adjusting

key	description
CD PLAY/ PAUSE	tracking servo on/off display B shows 05**:** if servo on display B shows 03--:-- if servo off
skip up	horizontal or vertical position choice display B shows 05V**:** in horizontal mode (servo gain and tracking bias)

#### 5-4-3 Pickup Movement

key	description
FF	pickup travels outwards and display B shows OUTSIDE.
FB	pickup travels inwards and display B shows INSIDE.

#### 5-4-4 Initialization in Test Mode

CD stop to playback. Display B shows 0100:00

### 5-5 Factory Test Check

#### 5-5-1 Initial Operation

Setting: Insert the power cord to the wall outlet with pressing the AUTO/MONO key.

Cancel: Turn power off.

1. Check sub clock oscillation. Display lights for 2 secs. If no problem.
2. Display A shows destination.
3. Display A shows sensor's condition with H or L after any key is pressed.

#### 5-5-2 Display Check

Display's dots light on or off by pressing MODE key.

Back light is always on.

#### 5-5-3 Slot Check

key	description
FF	slot in operation. Display B shows LOAD
FB	slot out operation. Display B shows UNLOAD.

## 6. Initialization

Setting: Insert the power cord to the wall outlet with pressing the STOP key.

Initialize amplifier section(preset,time reset and RAM) after CD mechanism initialization.

Turn unit to standby mode.

Display shows INITIALIZE for check time.

Display shows CD EER if any trouble.

## 7. Cancel of Test Mode

Initialized and cancel test mode if pulling out power cord.

Not initialized and cancel test mode if the power switch turns off.

Turn normal mode if pressing STOP key in stop condition of CD test mode.

## 8. Common Operation in Test Mode

1. Volume level is 40 at every test mode start up.
2. No muting with switching test mode. But muting-on if power switch on/off.
3. AUX test mode is available for selecting MD,TAPE, or AUX
4. Initialize setting value or condition if pull out the power cord.
5. AUX IN LEVEL is initialized to +3(0dB).
6. Input key is available for switching test mode item,tuner,cd, MD, tape and aux.

# RD-VH7

## CIRCUIT DESCRIPTION

### 9. Common Operation in AUX/TUNER Test Mode

#### 9-1 Bias and Main Volume Level

Set unit to aux or tuner test mode.

Select the proper value with CD PLAY/PAUSE or CD STOP key.

volume	bias	display D
0	pure A low	PURE#A#L
1	pure A low	PURE#A#L
20	pure A mid	PURE#A#M
40	pure A high	PURE#A#H
80	pure B low	PURE#B#L

Multi control knob is available for same setting after mode key is pressed.

#### 9-2 FAN Operation

Display C shows fan condition.

FAN	Display C
off	FAN#OFF#
low	FAN#low#
high	FAN#Hi##

## 10. MICROPROCESSOR ; M30622MC-570FP(X09,IC4)

### 10-1 MICROPROCESSOR PERIPHERY BLOCK DIAGRAM

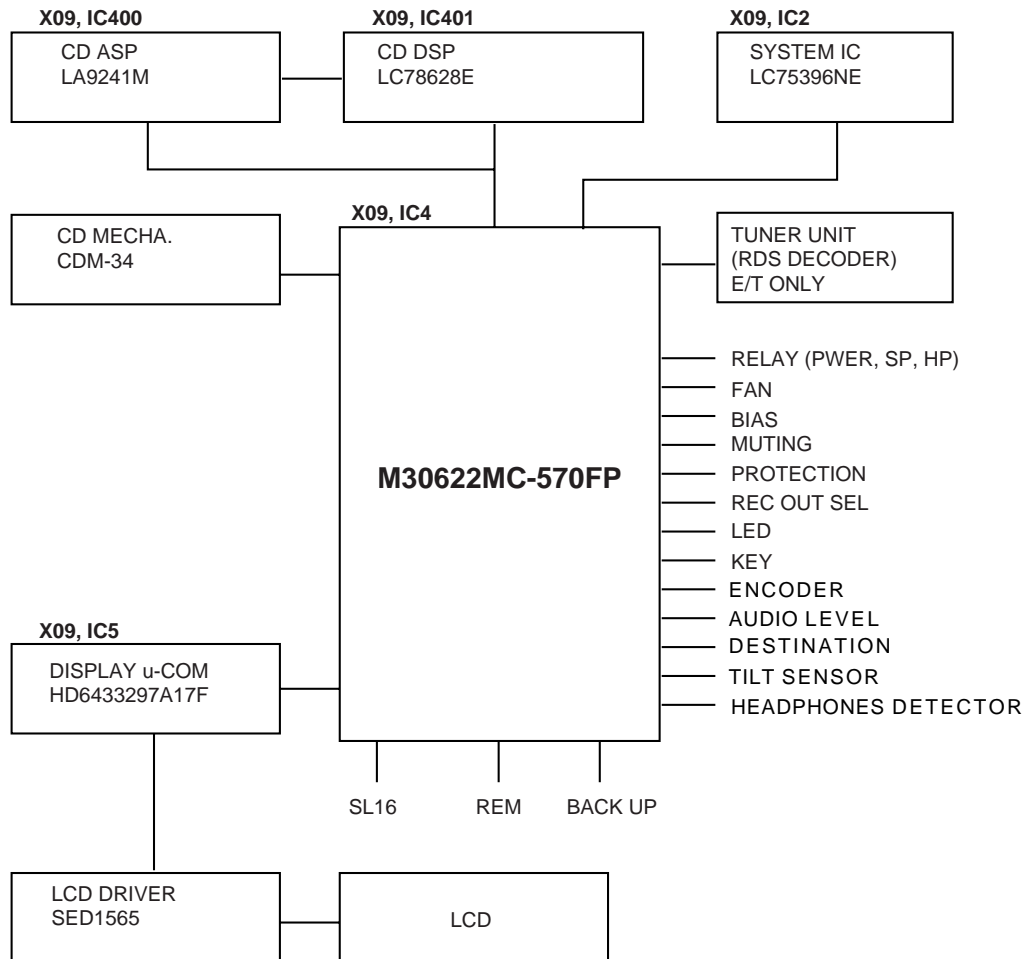

### KEY MATRIX

\* REFERENCE VOLTAGE: 5.0V

VOLTAGE	0.000 < ≤1.061	1.061 < ≤1.726	1.726 < ≤2.437	2.437 < ≤3.156	3.156 < ≤3.827	3.827 < ≤4.586	4.586 <
KEY1 89PIN			MODE		POWER		KEY OFF
KEY2 90PIN	STOP	SKIP DOWN	PLAY/PAUSE	INPUT	BAND		KEY OFF
KEY3 91PIN	SKIP UP	EJECT	TUNING UP	TUNING DOWN	AUTO/MONO		KEY OFF



## CIRCUIT DESCRIPTION

## 10-2 MICROPROCESSOR PIN DESCRIPTION

Pin No.	Pin Name	I/O	Description
1	RELAY HP	O	Headphones relay control terminal.
2	RELAY SP	O	Speaker relay control.
3	DISP_RST	O	Reset for communication between display u-COM and u-COM(IC4).
4	DISP CE	O	Chip enable for communication between display u-COM and u-COM(IC4).
5	DISP OUT	O	Data out for communication between display u-COM and u-COM(IC4).
6	DISP IN	I	Data In for communication between display u-COM and u-COM(IC4).
7	DISP CLK	O	Clock for communication between display u-COM and u-COM(IC4).
8	BYTE	I	Connected to ground.
9	CNVSS	I	Connected to ground.
10	XCIN	I	Clock (32.768kHz).
11	XCOU	O	Clock (32.768kHz).
12	RESET	I	Reset terminal of microprocessor.
13	XOUT	O	Main clock.
14	VSS	-	Ground.
15	XIN	I	Main clock.
16	VCC	-	Power supply(+5V).
17	NMI	I	Connected to power supply(+5V).
18	REMOCON	I	Remocon signal Input.
19	DQSY	I	Text data reading permission signal Input.
20	WRQ	I	Q code reading permission signal Input.
21	NC	O	Unused.
22	DIMMER	O	LCD back light dimmer.
23	COIN	O	Output terminal of u-COM data.
24	TGL	I	Change-over for tracking gain.
25	NC	O	Unused.
26	FSEQ	I	EMF synchronism signal Input.
27	NC	O	Unused.
28	CQCK	O	Clock output.
29	SQOUT	I	Sub code Q Input.
30,31	NC	O	Unused.
32	SRDT	I	Text data Input.
33	SCLK	O	Clock for text data.
34	SDA	O	Unused.
35	SCL	O	Unused.
36,37	NC	O	Unused.
38	CD_RST	O	Reset signal output.
39	DRF	I	Focus OK signal Input.
40	RWC	O	Read/write control output.
41	SL-	O	Moves the sled slightly toward the Inner position of disc.
42	SL+	O	Moves the sled slightly toward the outer position of disc.
43	LOADING	O	Change-over for mechanism loading(+/-).
44	LOAD MUTE	O	Change-over for mechanism loading(ON/OFF).
45	NC	O	Unused.
46	LOAD_SW	I	Detection terminal for disc.
47,48	NC	O	Unused.
49	12DISC_SW	I	12cm disc detection terminal.
50	DOWN_SW	I	Control port of down motor for mechanism.

## CIRCUIT DESCRIPTION

Pin No.	Pin Name	I/O	Descriptin
51	BACK_UP	I	Detection port for backup mode.
52	NC	O	Unused.
53,54	ENC1/2	I	Rotary encoder1/2 Input.
55	SL16 DATA	I/O	SL16 data input/output.
56	SL16 BUSY	I/O	SL16 busy input/output.
57	STBYLED	O	LED3 standby(red).
58	ON LED	O	LED2 standby(grn).
59	EJECTLED	O	LED1 (eject).
60	MD REC SEL	O	Control terminal for MD rec.
61	TAPE REC SEL	O	Control terminal for TAPE rec.
62	VCC	-	Power supply.
63	TILT SENS	I	Detection terminal of FL lenght and breadth conditions.
64	VSS	-	Ground.
65	NC	O	Unused.
66	A-MUTE	O	Audio muting control.
67	-10V CONT.	O	Control terminal for LCD power supply(-10V).
68	BIAS HIGH	O	Bias control(HIGH).
69	BIAS MID	O	Bias control(MID).
70~72	DSW0~2	I	Discrimination of model destination(SW0~2).
73	STEREO	I	Detection terminal of stereo signal for TUNER.
74	SD	I	Detection terminal of SD signal for TUNER.
75	RDS CLK	I	RDS clock Input.(E/T version only)
76	RDS DATA	I	RDS data Input.(E/T version only)
77	PLL DO	I	PLL IF count Input.
78	CE	O	Chip enable to LC75396(IC2) and LC72131(tuner pack IC2).
79	DATA	O	Data to LC75396(IC2) and LC72131(tuner pack IC2).
80	SCLK	O	Clock to LC75396(IC2) and LC72131(tuner pack IC2).
81	T_MUTE	O	TUNER muting control.
82	(EMPHASIS)	O	DE-EMPHASIS control.
83	CD ON/OFF	O	Unused.
84	NC	O	Unused.
85	FAN_H/L	O	Fan H/L change-over.
86	FAN ON/OFF	O	Fan ON/OFF control.
87	POWER RE	O	Power relay control. H = ON L = OFF
88	PROTECT	I	Detection terminal of protection. H =protection ON
89~91	KEY1~3	O	Key A/D Input 1~3.
92,93	PT4,3	I	Detection terminal of 8cm disc.
94	A LEVEL	I	Audio level Input(A/D).
95	RDS SLEVEL	I	RDS signal level Input(A/D). (E/T version only)
96	AVSS	-	A/D ground.
97	PROTECT TEMP	I	Detection terminalfor temperature compensating.
98	VREF	-	A/D reference voltage.
99	AVCC	-	A/D power supply(+5v).
100	HP_IN	I	Headphones detection terminal.

## CIRCUIT DESCRIPTION / CD MECHANISM DESCRIPTION

### CIRCUIT DESCRIPTION

#### 10-3 CONTROL PORT OF MICROPROCESSOR

##### 10-3-1 TILT SENSOR

LCD INDICATION	TILT SENS (63PIN)
HORIZONTAL	L
VERTICAL	H

##### 10-3-2 REC OUT SELECTOR

RECOUT	REC SELA (61PIN)	REC SELB (60PIN)
MD	L	H
TAPE	H	L

##### 10-3-3 HEADPHONES/SPEAKER CONTROL

PORT	HP_IN	RELAY SAP (2PIN)	RELAY HP (1PIN)
H/P (YES)	H	L	H
H/P (NO)	L	H	L

##### 10-3-4 PURE A, FAN, BIAS

VOLUME VALUE	PURE A INDICATION	BIAS	
		MID 69Pin	HIGH 68Pin
0	OFF	L	L
1~9	ON	L	L
10~29	ON	H	L
30~49	ON	L	H
50~	OFF	L	L

AUDIO LEVEL VALUE	FAN	
	ON/OFF 86Pin	H/L 85Pin
0~0.9V	H	H
1.0~3.9	L	H
4.0~	L	L

### CD MECHANISM DESCRIPTION

#### Mechanism jam cancel method

1. Move a disc with roller ④ : Move the gear ⑰ for CW with your finger → Move the roller ④ → Eject a disc
2. Cannot move 8cm disc without method 1.: Remove the 2 screws ⑱, then remove sub assy ⑲.

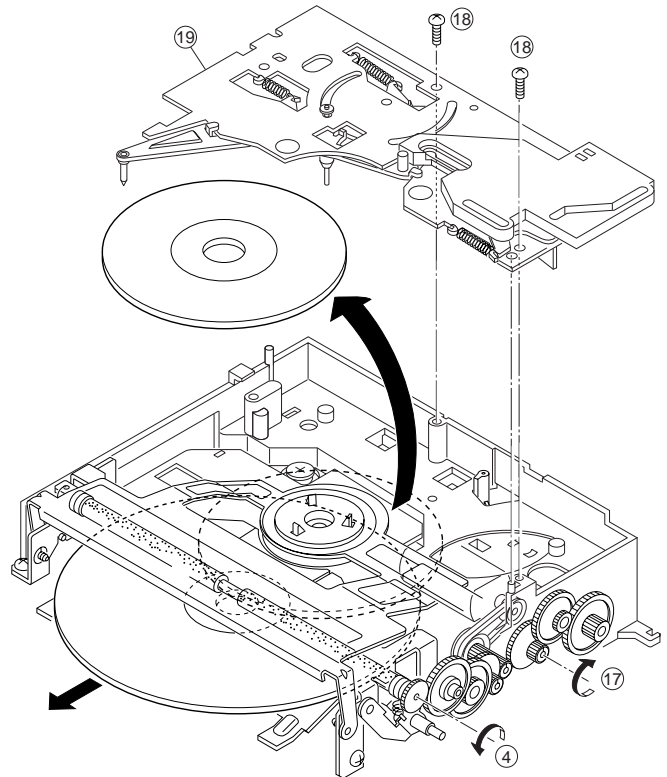

# RD-VH7

## CD MECHANISM DESCRIPTION

The initialization position of mechanism is the slider (loading) ① position at the back most. The mechanism moves from this position.

### 1. 8cm DISC loading in

1) Insert a disc → Check by a disc detection sensor ② (prism reflection ray OFF) → Start loading motor ③ → Move the roller ④ → Pull in a disc

2) Push the shaft of the arm assy (trigger A) ⑤ with a disc → Move the arm assy (trigger B) ⑥ → Move the arm (trigger) ⑦

This time, decide PLAY position of a disc by the stoppers (shaft) of the arm assy (L) ⑧ and the arm assy (R) ⑨.

3) Move the arm (trigger) ⑦ → Push out the slider (loading) ① for front → Move the gear (final) ⑩ → Move the slider (loading) ① for this side → Loading down the clamber of sub chassis ⑪ and the roller ④ → Finish a disc catching

4) Move the slider (loading) ① for this side → Move the slider (disc guide) ⑫ for right direction → Came off the moved lock of the arm assy (lock) ⑬ → Move the arm assy (L) ⑧ and the arm assy (R) ⑨ → Keep off the stoppers from a disc. → Move the slider (loading) ① for this side → Turn on the switch ⑭ → PLAY a disc

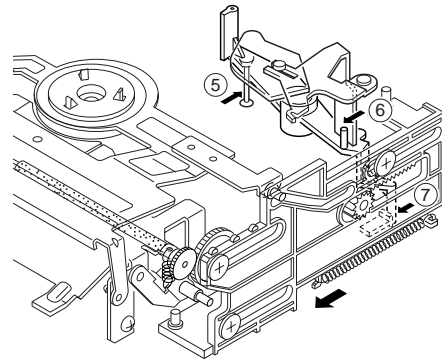
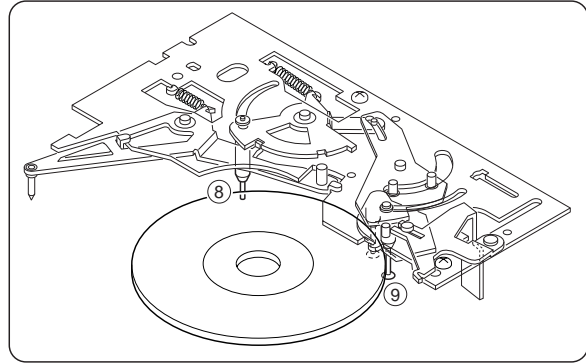

Note:  
Set the loading slider to full backward if reinstall it.

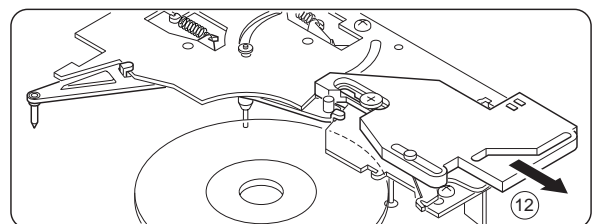
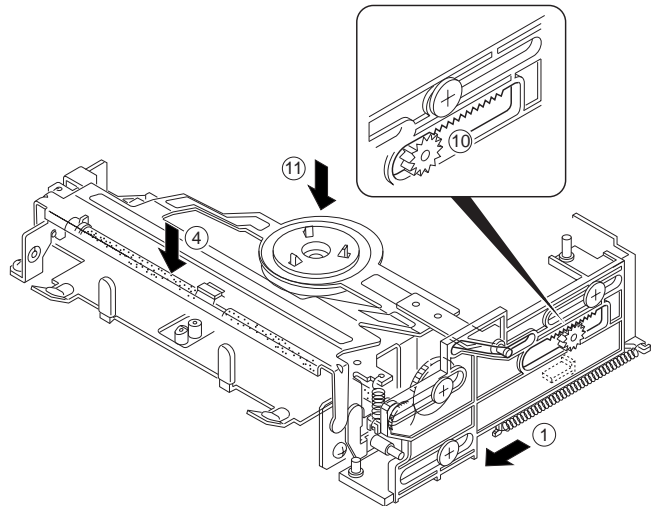
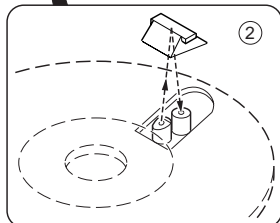
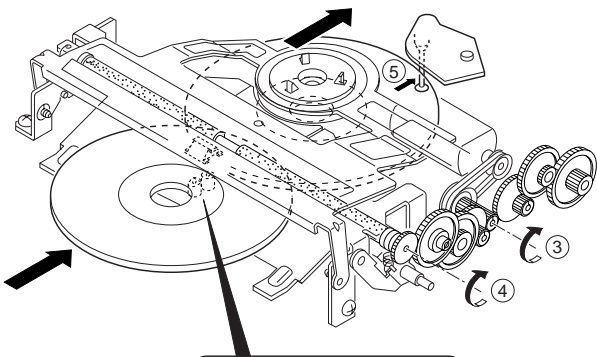
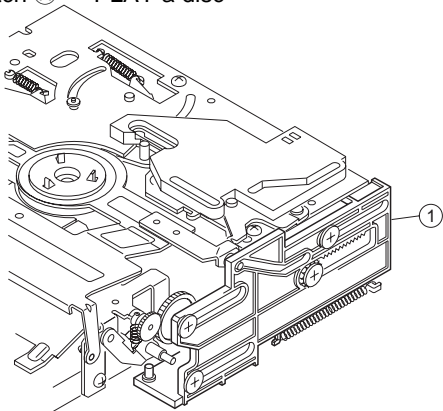

## CD MECHANISM DESCRIPTION

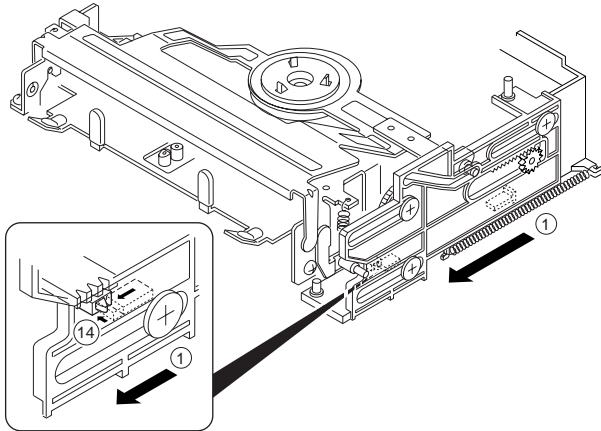
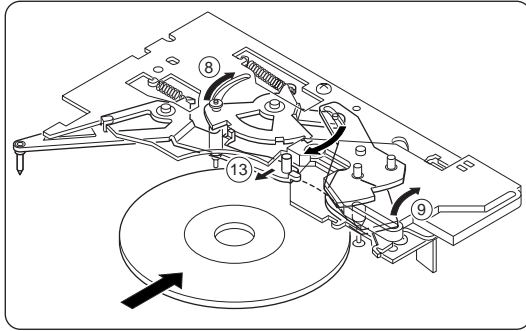

### 2. 12cm DISC loading in

- 1) The same 8cm DISC loading in
- 2) Push the arm assy (lock) 13 with a disc → Keep apart the lock of the arm assy(L) 8 → Decide PLAY position with the stoppers of the arm assy (L) 8 and the arm assy (R) 9 → Keep off the stoppers from a disc This time, move the arm (trigger) 7 with a disc.
- 3) The same 8cm DISC loading in
- 4) The same 8cm DISC loading in

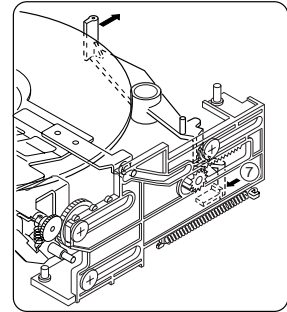
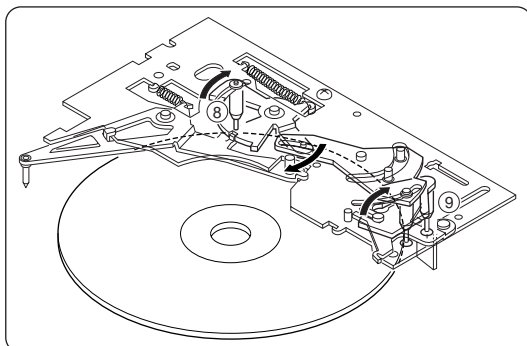
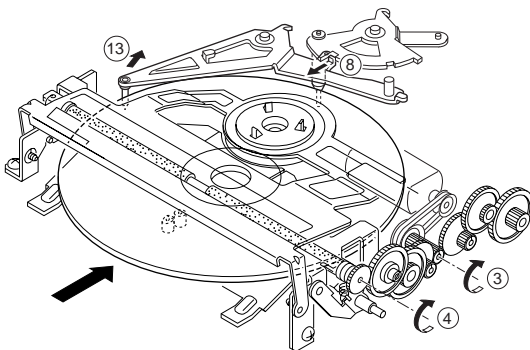

### 3. Loading out

This moving become contrary moving of loading in.  
Final, a disc touch the 8cm disc eject sensor 15 or the 12cm disc eject sensor 16 → Stop the loading motor 3  
→ Loading out finish

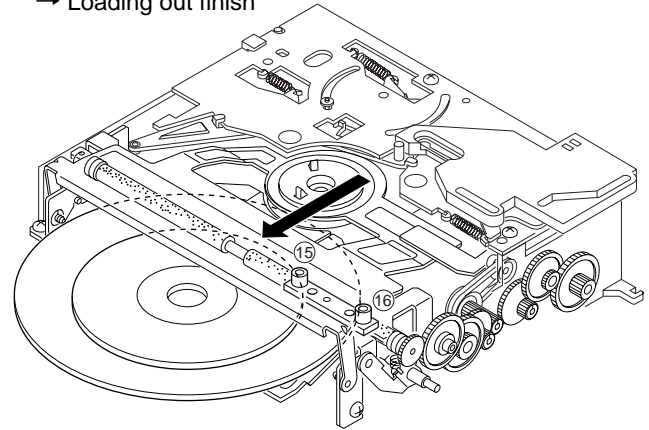

### 4. Lock and cancel of insulation mechanism

The initialization position of mechanism is the slider(loading) 1 position at the back most. This position become the insulation mechanism lock. Change the mechanism on this position normal.

Move the slider(loading) 1 for this side → Move the slider(chassis lock) 17 for right direction → Cancel the mechanism lock → The mechanism become the insulation effect

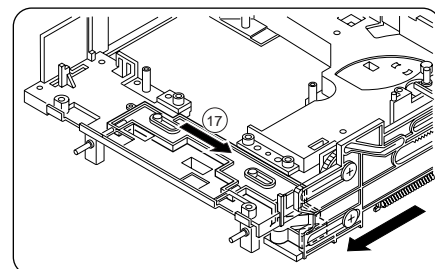
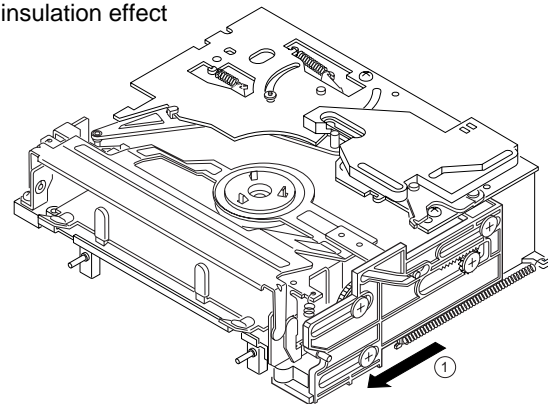

## ADJUSTMENT

## CD section

NO.	ITEM	INPUT SETTINGS	OUTPUT SETTINGS	CD PLAYER SETTINGS	ALIGNMENT	ALIGN FOR	FIG.
TEST MODE : While pressing the PLAY/PAUSE key ,plug the power cord into the AC power wall output. Insert TEST DISC.							
[1]	LASER CURRENT CHECK	Test disc type 4	Set the tester across R502(1Ω) on the PCB(X09:D/4) of CD mechanism .	Press the PLAY/PAUSE key to check that the display is 03 or 05.	-	50±20mA	
[2]	FOCUS ERROR BIAS (Set up vertically)	Test disc type 4	Connect an oscilloscope and jitter meter as follows. CH1:RF(CN402:7pin) CH2:FE1(CN402:6pin) GND:VC(CN402:4pin)	Press the PLAY/PAUSE key . Confirm that the display is 05.	FE BIAS VR401	Optimum eye pattern	
[3]	FOCUS ERROR BIAS (Set up vertically)	Test disc type 4	Connect an oscilloscope and jitter meter as follows. RF IN:RF(CN402:7pin) CH2:FE1(CN402:6pin) GND:VC(CN402:4pin)	Press the PLAY/PAUSE key . Confirm that the display is 05.	FE BIAS VR401	Jitter level minimum	
[4]	FOCUS ERROR BIAS (Set up horizontally)	Test disc type 4	Connect an oscilloscope and jitter meter as follows. CH1:RF(CN402:7pin) CH2:FE1(CN402:6pin) GND:VC(CN402:4pin)	Press the PLAY/PAUSE key . Confirm that the display is 05.	FE BIAS VR400	Optimum eye pattern	
[5]	FOCUS ERROR BIAS (Set up horizontally)	Test disc type 4	Connect an oscilloscope and jitter meter as follows. RF IN:RF(CN402:7pin) CH2:FE1(CN402:6pin) GND:VC(CN402:4pin)	Press the PLAY/PAUSE key . Confirm that the display is 05.	FE BIAS VR400	Jitter level minimum	

## Note:

- Type 4disc: SONY YDS-18 Test Disc or equivalent.
- This unit needs to be adjusted by Jitter meter.
- Keep the step of adjustment.

## PARTS DESCRIPTIONS

### CAPACITORS

CC 45 TH 1H 220 J  
 1 2 3 4 5 6

- 1 = Type ... ceramic, electrolytic, etc.
- 2 = Shape ... round, square, ect.
- 3 = Temp. coefficient
- 4 = Voltage rating
- 5 = Value
- 6 = Tolerance

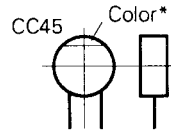

#### • Capacitor value

- 010 = 1pF
- 100 = 10pF
- 101 = 100pF
- 102 = 1000pF = 0.001μF
- 103 = 0.01μF

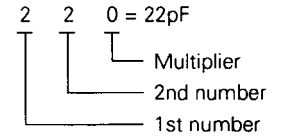

#### • Temperature coefficient

1st Word	C	L	P	R	S	T	U
Color*	Black	Red	Orange	Yellow	Green	Blue	Violet
ppm/°C	0	-80	-150	-220	-330	-470	-750

2nd Word	G	H	J	K	L
ppm/°C	±30	±60	±120	±250	±500

Example : CC45TH = -470 ± 60ppm/°C

#### • Tolerance (More than 10pF)

Code	C	D	G	J	K	M	X	Z	P	No code
(%)	±0.25	±0.5	±2	±5	±10	±20	+40 -20	+80 -20	+100 -0	More than 10μF - 10 ~ +50 Less than 4.7μF -10 ~ +75

#### (Less than 10pF)

Code	B	C	D	F	G
(pF)	±0.1	±0.25	±0.5	±1	±2

#### • Voltage rating

2nd word	A	B	C	D	E	F	G	H	J	K	V	
1st word	0	1.0	1.25	1.6	2.0	2.5	3.15	4.0	5.0	6.3	8.0	-
1	10	12.5	16	20	25	31.5	40	50	63	80	35	-
2	100	125	160	200	250	315	400	500	630	800	-	-
3	1000	1250	1600	2000	2500	3150	4000	5000	6300	8000	-	-

#### • Chip capacitors

(EX) C C 7 3 F S L 1 H 0 0 0 J  
 1 2 3 4 5 6 7

(Chip) (CH, RH, UJ, SL)

(EX) C K 7 3 F F 1 H 0 0 0 Z  
 1 2 3 4 5 6 7

(Chip) (B, F)

Refer to the table above.

- 1 = Type
- 2 = Shape
- 3 = Dimension
- 4 = Temp. coefficient
- 5 = Voltage rating
- 6 = Value
- 7 = Tolerance

#### Dimension (Chip capacitors)

Dimension code	L	W	T
Empty	5.6 ± 0.5	5.0 ± 0.5	Less than 2.0
A	4.5 ± 0.5	3.2 ± 0.4	Less than 2.0
B	4.5 ± 0.5	2.0 ± 0.3	Less than 2.0
C	4.5 ± 0.5	1.25 ± 0.2	Less than 1.25
D	3.2 ± 0.4	2.5 ± 0.3	Less than 1.5
E	3.2 ± 0.2	1.6 ± 0.2	Less than 1.25
F	2.0 ± 0.3	1.25 ± 0.2	Less than 1.25
G	1.6 ± 0.2	0.8 ± 0.2	Less than 1.0

### RESISTORS

#### • Chip resistor (Carbon)

(EX) R K 7 3 E B 2 B 0 0 0 J  
 1 2 3 4 5 6 7

(Chip) (B,F)

#### • Carbon resistor (Normal type)

(EX) R D 1 4 B B 2 C 0 0 0 J  
 1 2 3 4 5 6 7

- 1 = Type
- 2 = Shape
- 3 = Dimension
- 4 = Temp. coefficient
- 5 = Rating wattage
- 6 = Value
- 7 = Tolerance

#### Dimension

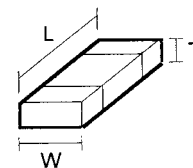

#### Dimension (Chip resistor)

Dimension code	L	W	T
E	3.2 ± 0.2	1.6 ± 0.2	1.0
F	2.0 ± 0.3	1.25 ± 0.2	1.0
G	1.6 ± 0.2	0.8 ± 0.2	0.5 ± 0.1

#### Rating wattage

Code	Wattage	Code	Wattage	Code	Wattage
1J	1/16W	2C	1/6W	3A	1W
2A	1/10W	2E	1/4W	3D	2W
2B	1/8W	2H	1/2W		

# PC BOARD (Component side view)

X14-4960-11 A/6: KMY 2-71: TE (J70-1306-21)

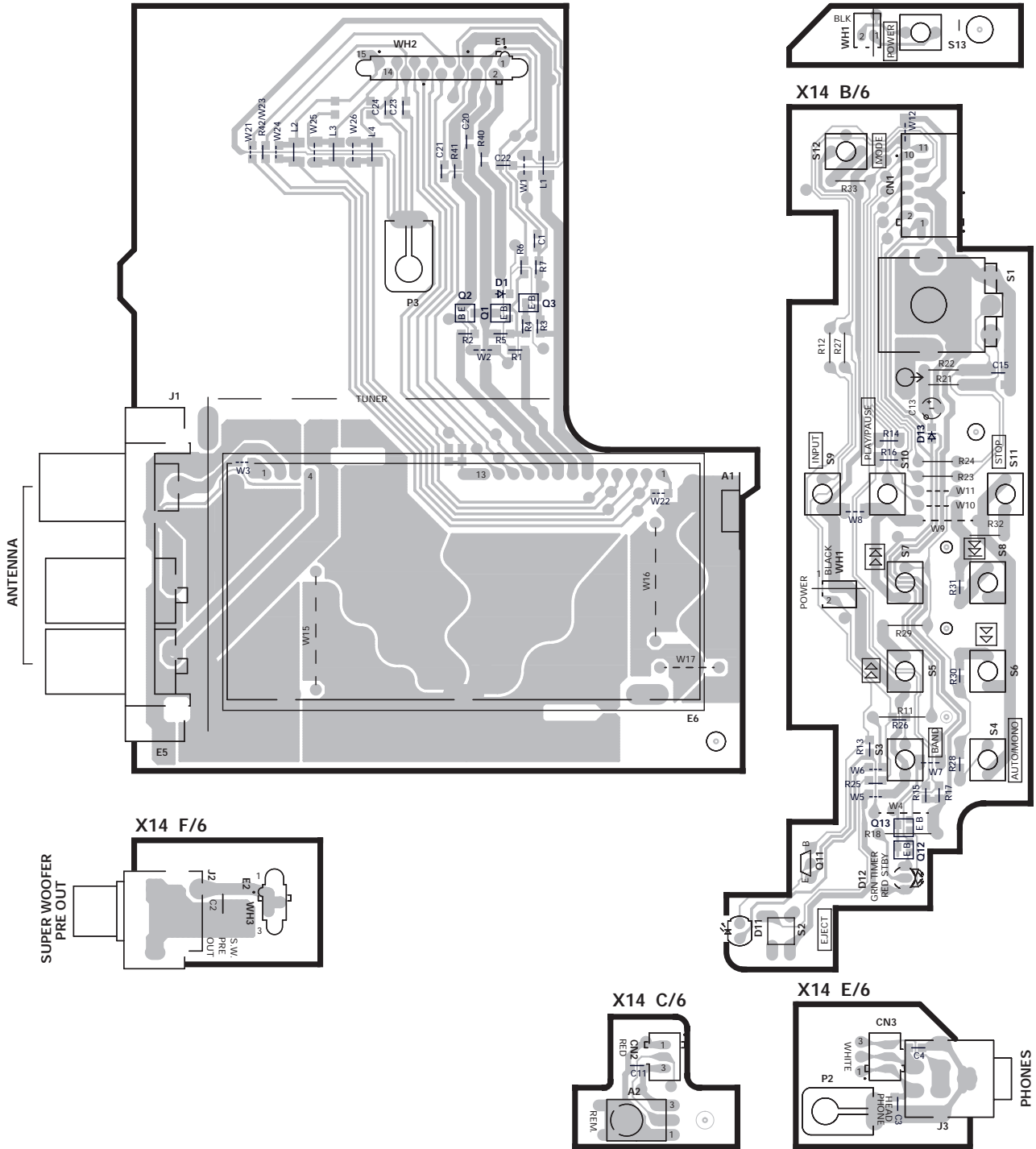



# PC BOARD (Component side view)

X09-6320-11 A/4: KY 0-21: M 2-71: TE (J70-1305-31)

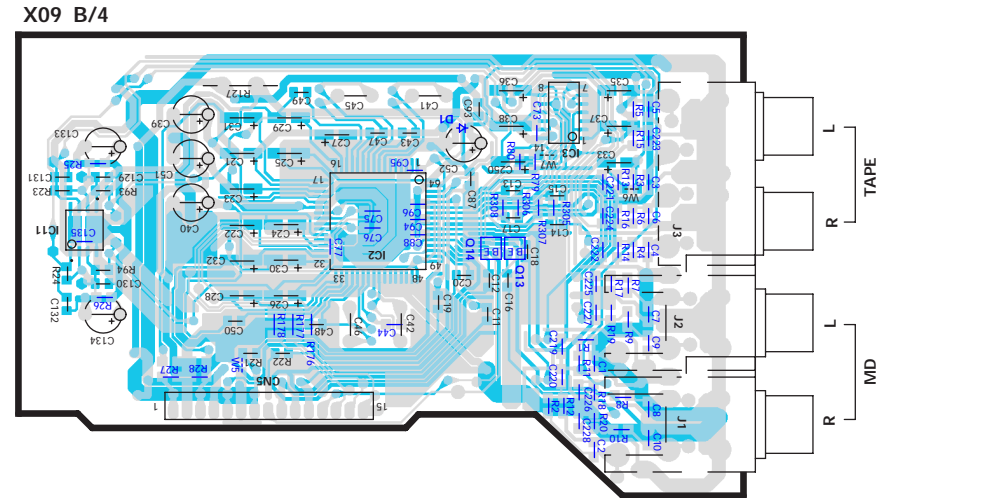
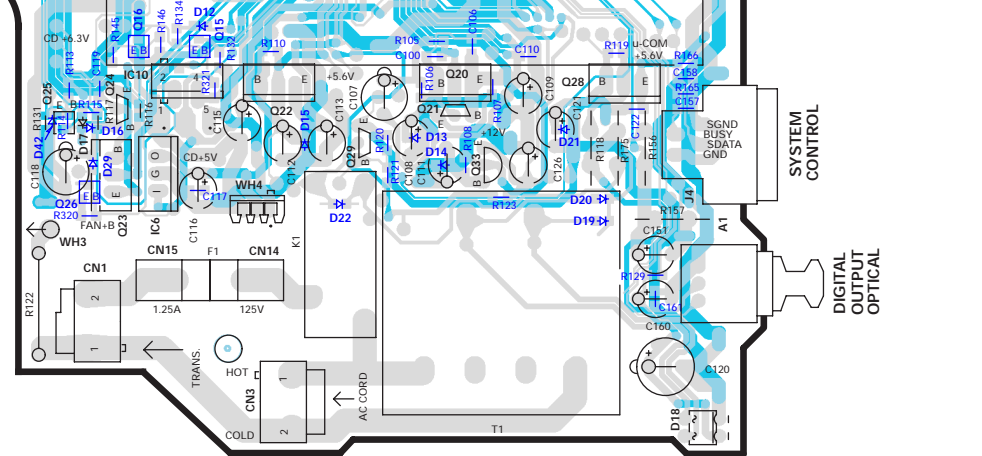
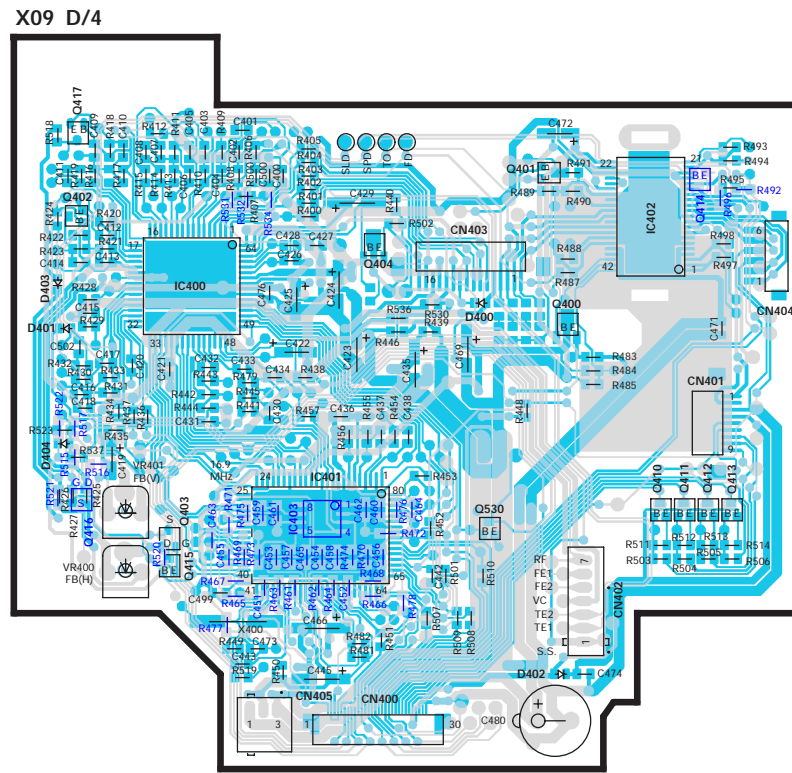
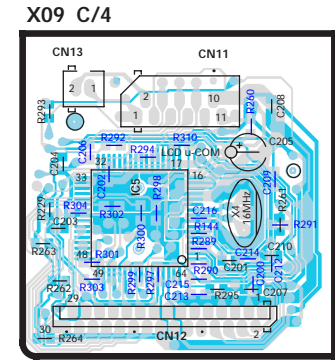
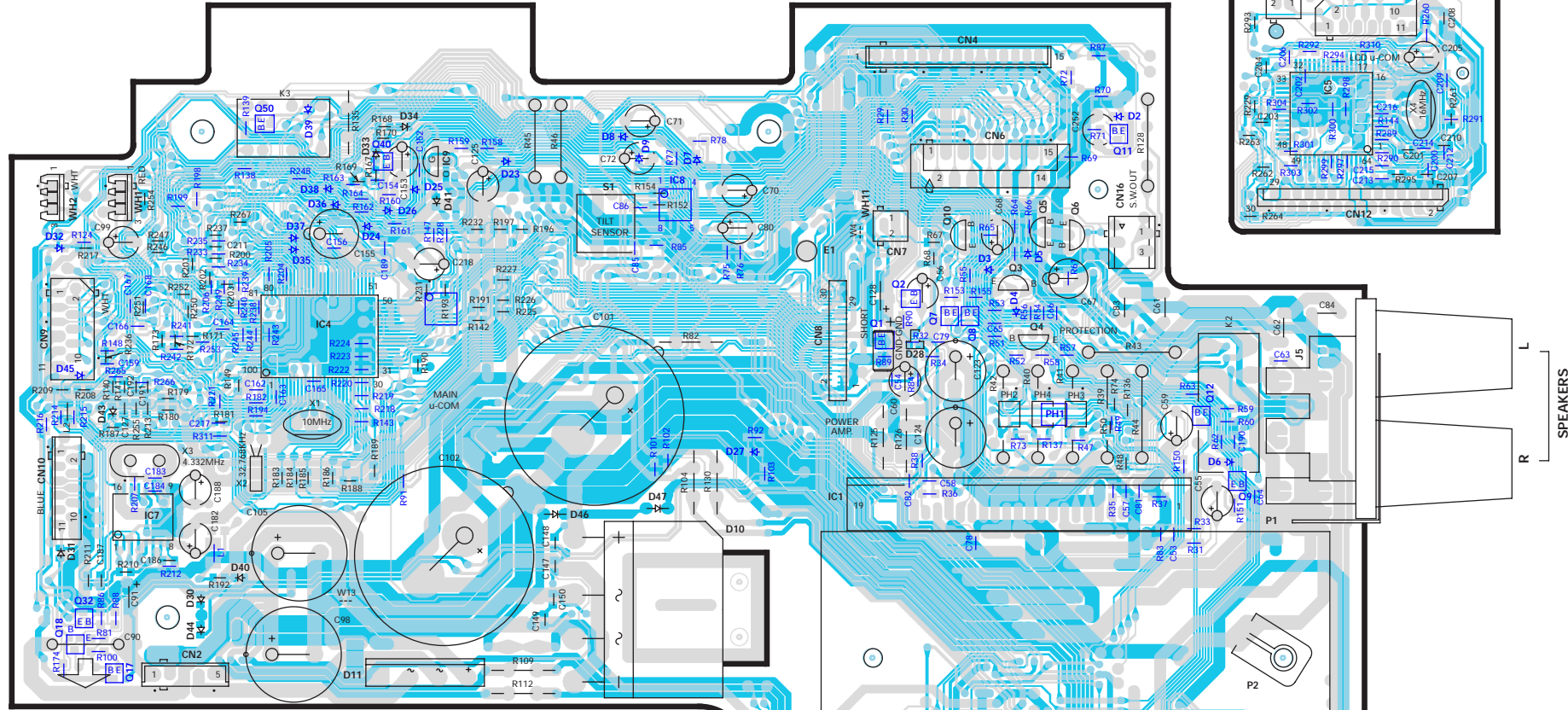

CD MECHANISM (D40-1638-05) / CDM-34

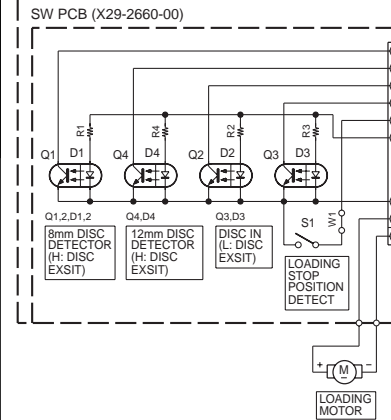
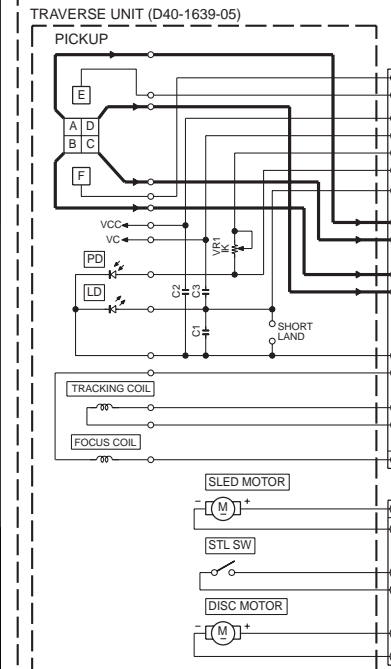

- IC400 : LA9241M
- IC401 : LC78628E
- IC402 : M56788FP
- IC403 : NJM2100M
- Q400,404 : 2SB1424(Q,R)
- Q401,530 : DTC124EUA or UN5212
- Q403,416 : 2SK209(Y,GR)
- Q410-413 : 2SA1576A(S)
- Q414,415 : UN5216 or DTC143TUA
- D400-404 : MA111

— SIGNAL LINE  
— GND LINE  
— +B LINE

**CAUTION:** For continued safety, replace safety critical components only with manufacturer's recommended parts (refer to parts list).  $\Delta$  indicates safety critical components. For continued protection against risk of fire, replace only with same type and rating fuse(s). To reduce the risk of electric shock, leakage-current or resistance measurements shall be carried out (exposed parts are acceptably insulated from the supply circuit) before the appliance is returned to the customer.

The DC voltage is an actual reading measured with a high impedance type voltmeter. The measurement value may vary depending on the measuring instruments used or on the product. Refer to the voltage during PLAY unless otherwise specified; The value shown in ( ) is the voltage measured at the moment of STOP.

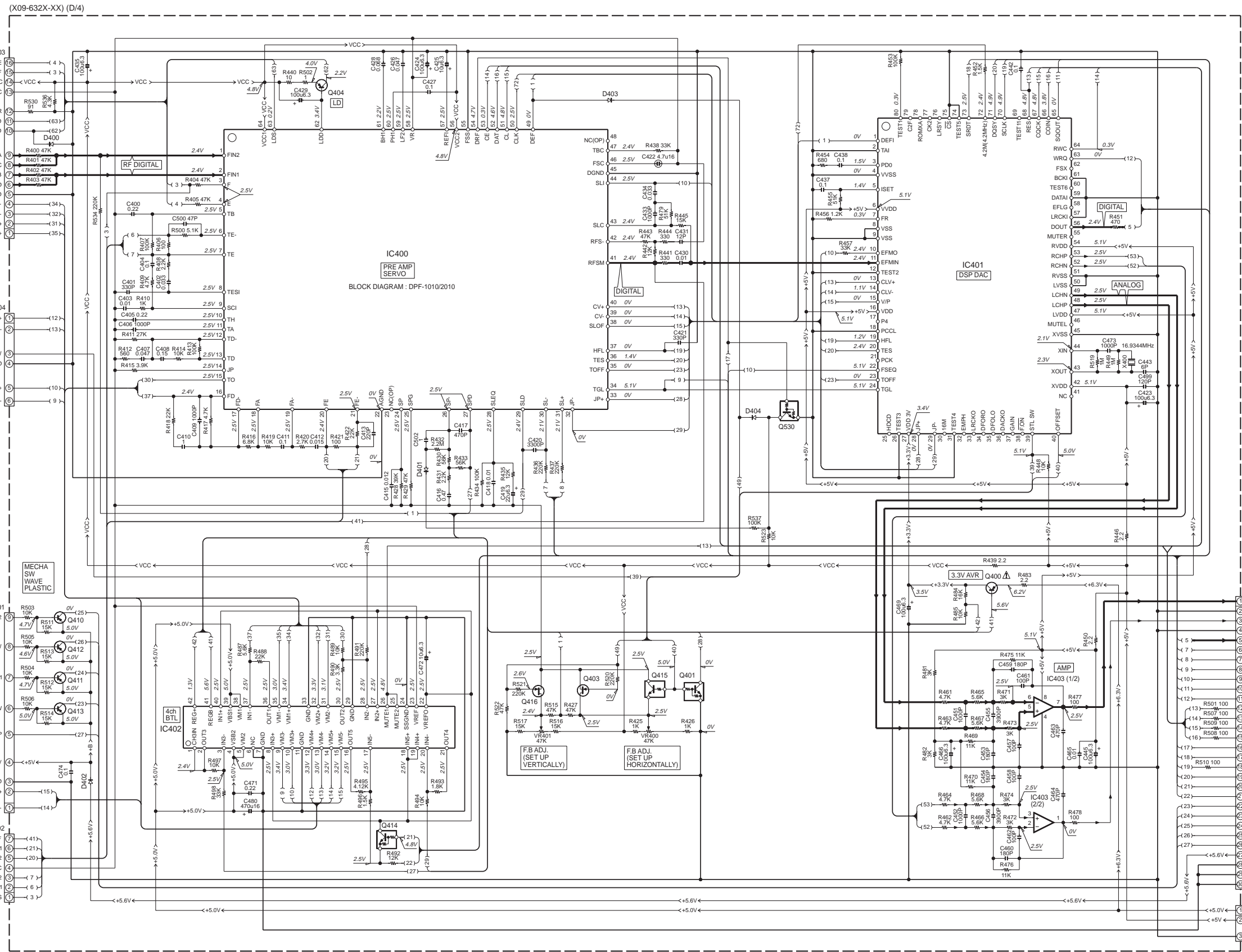

2SA992  
2SB764  
2SC1845

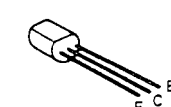

2SC2785

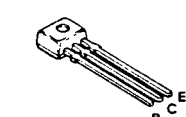

2SC1740S

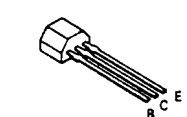

DTC143TUA  
UN5216  
UN5219  
2SA1576A  
2SA1586  
2SC4116

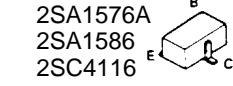

2SD2012  
2SD2495\*2



2SC4081

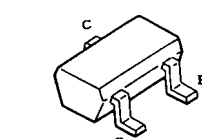

DTA124EUA  
DTC124EUA

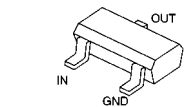

SAA6579T/R

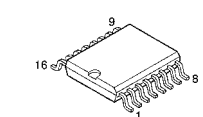

**RD-VH7**  
KENWOOD

Y39-3170-11

(X14-496X-XX) (A/6)

DESTINATION	COUNTRY	ABB.	UNIT No.	A1	W3	W21-26	R42	L2-4	C1	C20-24	P3
JAPAN	J		0-00	W02-2672-15	NO	YES	NO	NO	YES	NO	NO
JAPAN	J2										
U.S.A.	K		0-11	W02-2673-15	NO	YES	NO	NO	YES	NO	NO
PX	Y										
GENERAL MARKET	M										
U.K.	T		2-71	W02-2674-15	YES	NO	YES	YES	NO	YES	YES
EUROPE	E										

(X09-6320-00) (B/4)

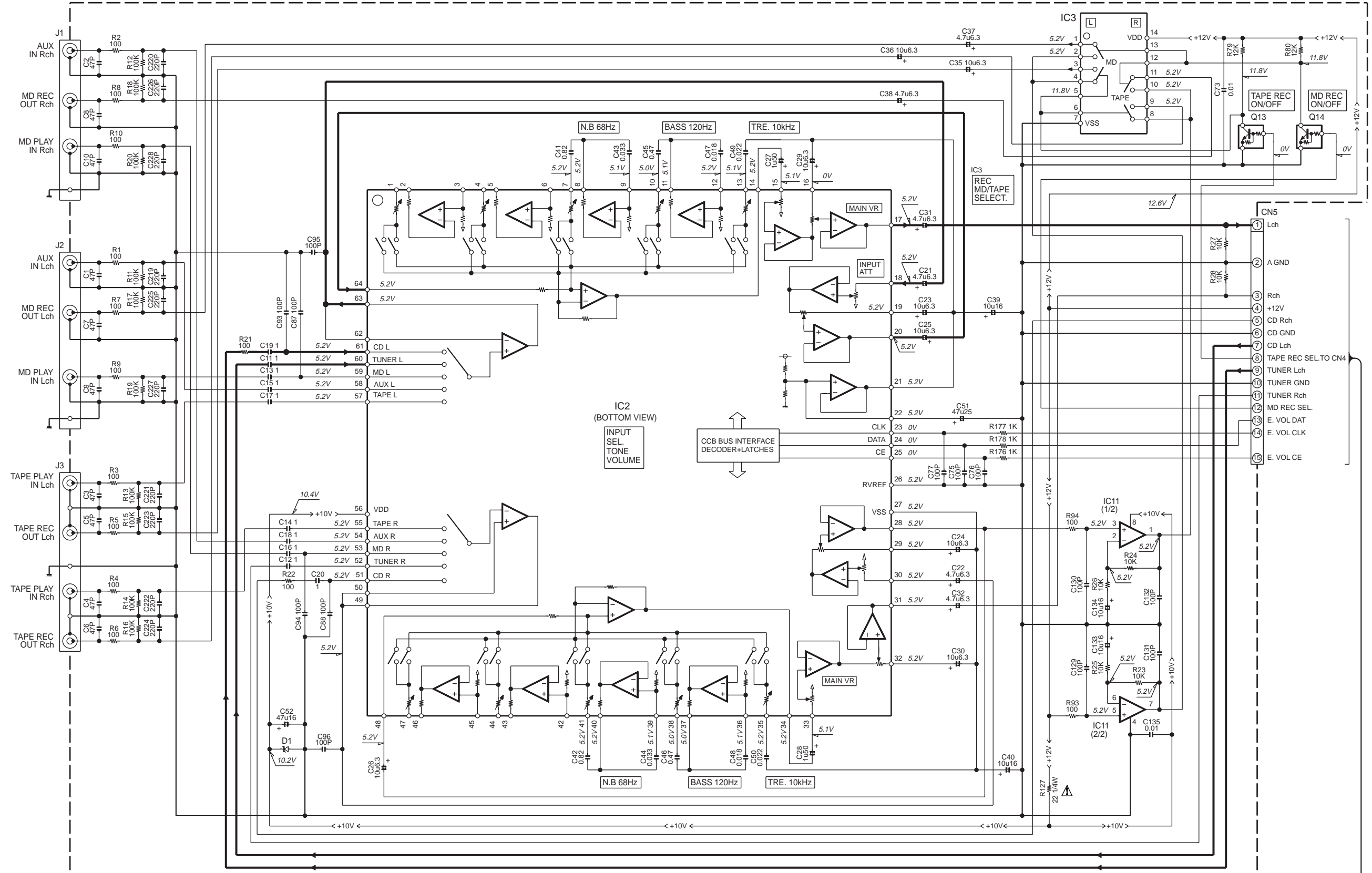

——— SIGNAL LINE  
 ——— GND LINE  
 <+B ← +B LINE  
 <-B ← -B LINE

IC2 : LC75396NE  
 IC3 : BU4066BCF  
 IC11 : NJM4565M  
 D1 : UDZ10B  
 Q13,14 : UN5219

(X14-496X-XX) (A/6)

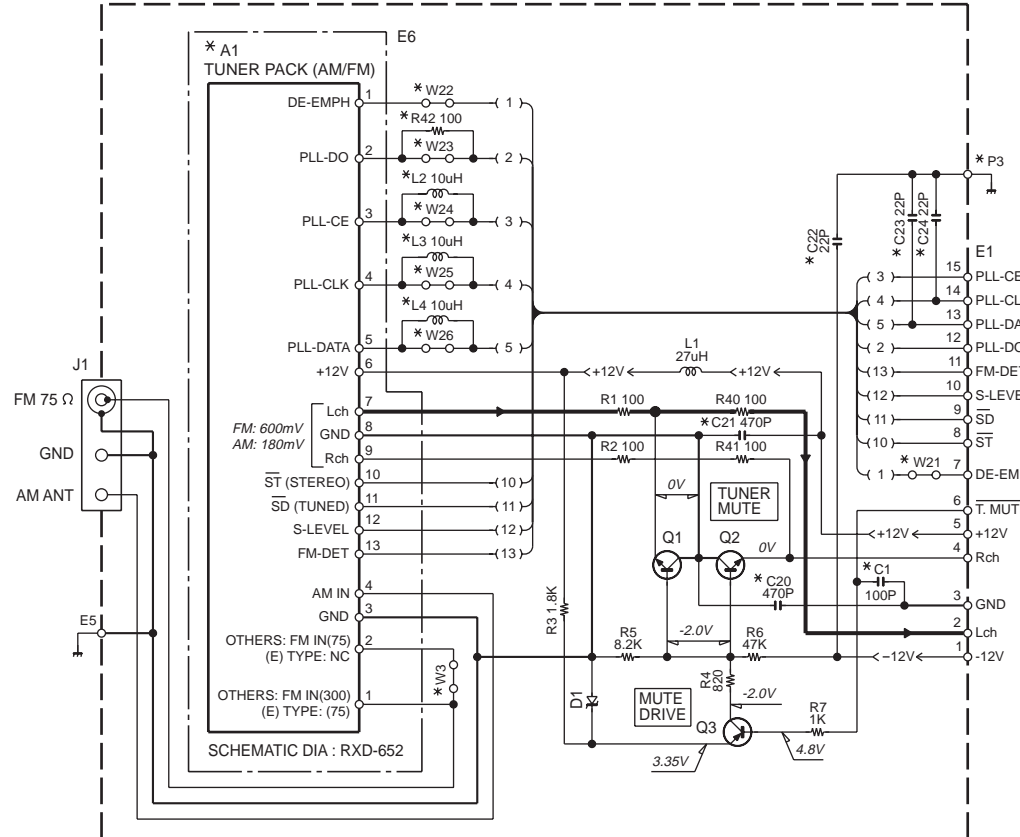

	PIN No.												
FM	0V	0.2V	5.0V	0.2V	11.9V	0.3V	5.4V	0.3V	3.6V	2.8V			
AM	0V	0.2V	5.0V	0.2V	12.0V	0.2V	5.4V	0.4V	0.2V	0.1V			

Q1,2 : 2SC4213(B)  
 Q3 : 2SA1611(M5,M6) or 2SA1586(Y,GR)  
 D1 : UDZ3.3B

(X14-496X-XX) (B/6)

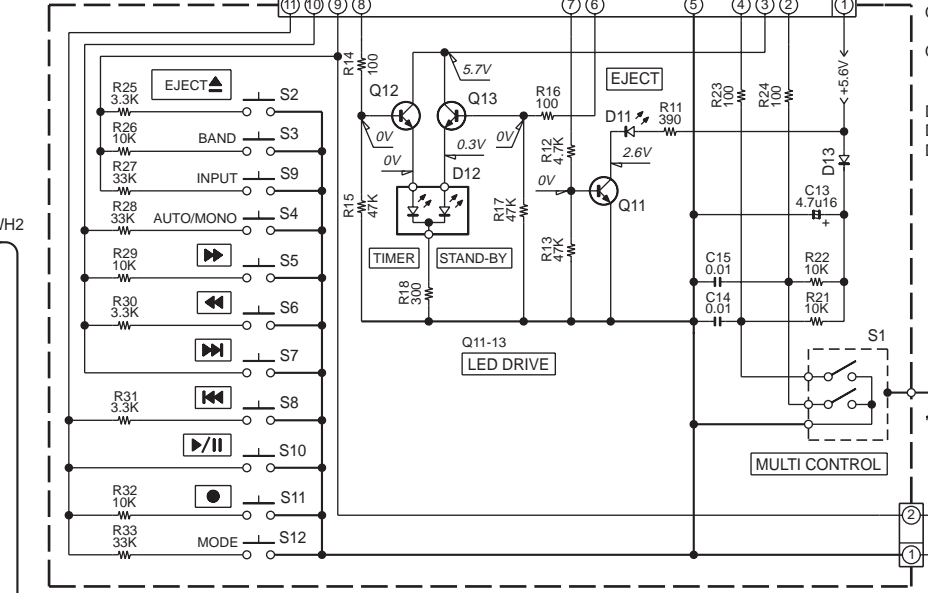

Q11 : 2SC1740S(Q,R) or 2SC2785(F,E)  
 Q12,13 : 2SC4081(R,S) or 2SC4116(Y,GR)  
 D11 : B30-2551-05  
 D12 : B30-2522-05  
 D13 : MA111

MODE	CARRIER	MODULATION		ANT INPUT
		FREQUENCY	DEVIATION	
FM	98MHz	1kHz	STEREO 67.5kHz 7.5kHz(Pilot)	60dB
AM	1000(999)kHz	400Hz	MONO 30% MOD	60dB

**CAUTION:** For continued safety, replace safety critical components only with manufacturer's recommended parts (refer to parts list).  $\Delta$  indicates safety critical components. For continued protection against risk of fire, replace only with same type and rating fuse(s). To reduce the risk of electric shock, leakage-current or resistance measurements shall be carried out (exposed parts are acceptably insulated from the supply circuit) before the appliance is returned to the customer.

The DC voltage is an actual reading measured with a high impedance type voltmeter as the AM/FM signal generator is specified to the conditions as shown in the list below. The measurement value may vary depending on the measuring instruments used or on the product. The value shown in ( ) is actual reading measured in the AM mode.

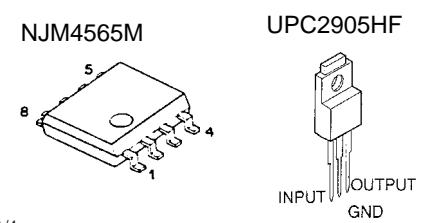
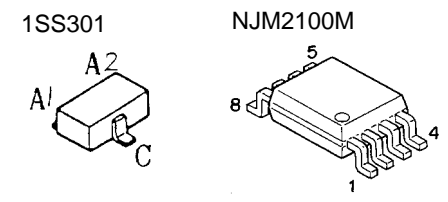
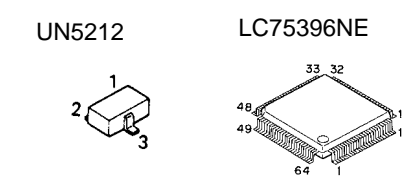
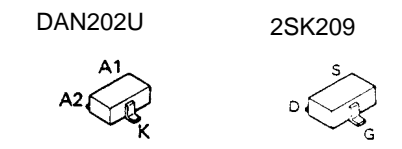
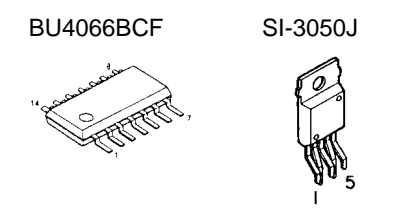

LCD DISPLAY ASS'Y (B30-0180- \* 5)

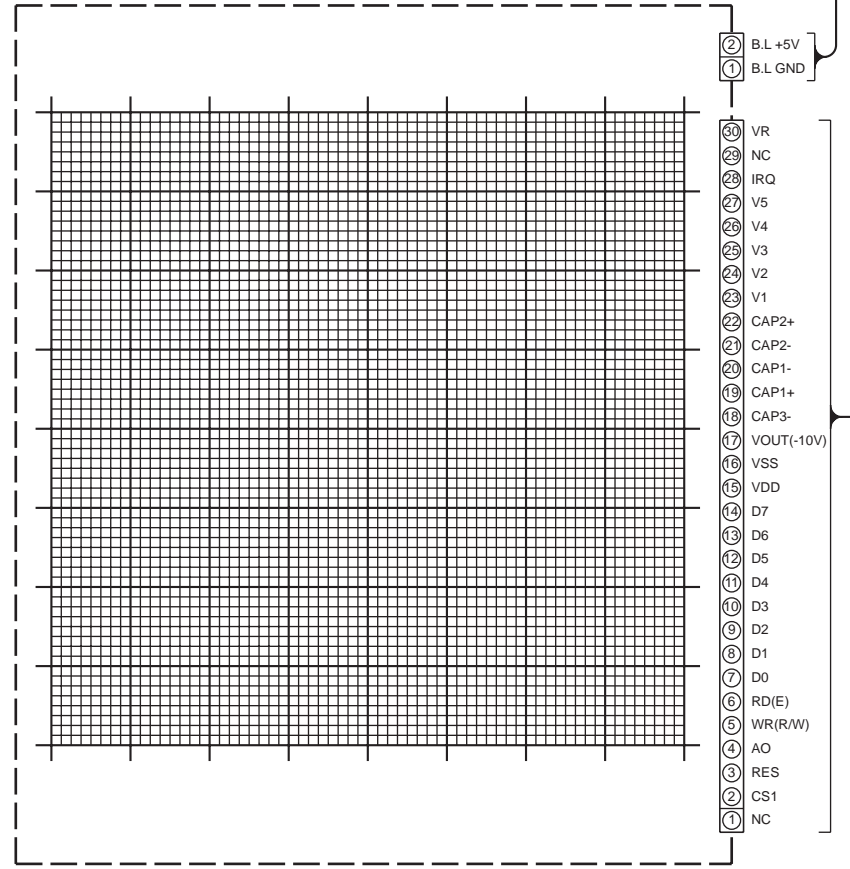

(X09-) (C/4)

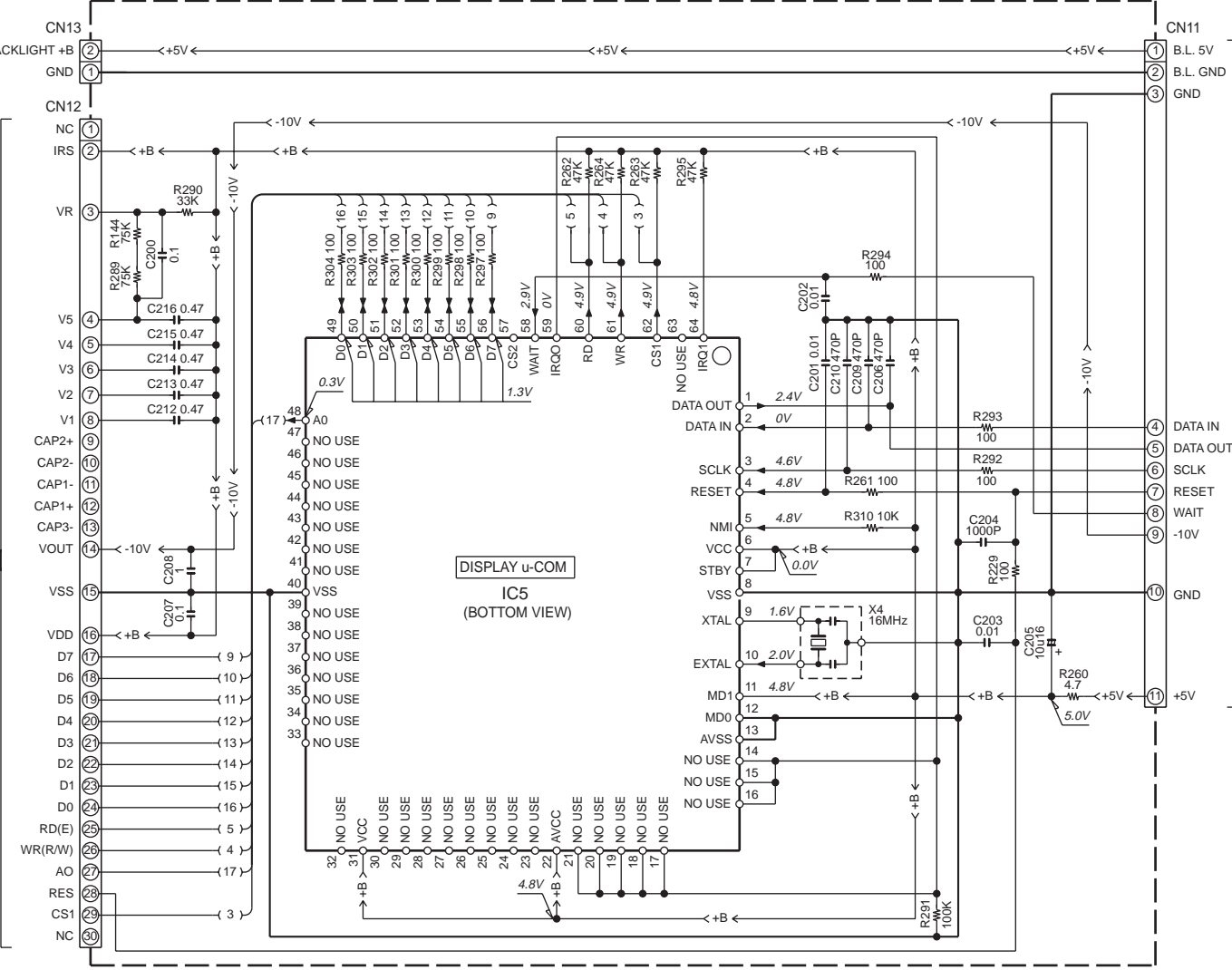

IC5 : HD6433297A17F

RD-VH7(K) (2/3)

X09-A/4 -CN9  
 3/3  
 C

X09-A/4 -CN6  
 3/3  
 D

X09-A/4 -CN10  
 3/3  
 E

X09-A/4 -CN4  
 3/3  
 F

Y39-3170-11

**RD-VH7**  
**KENWOOD**

(X09-632X-XX) (A/4)

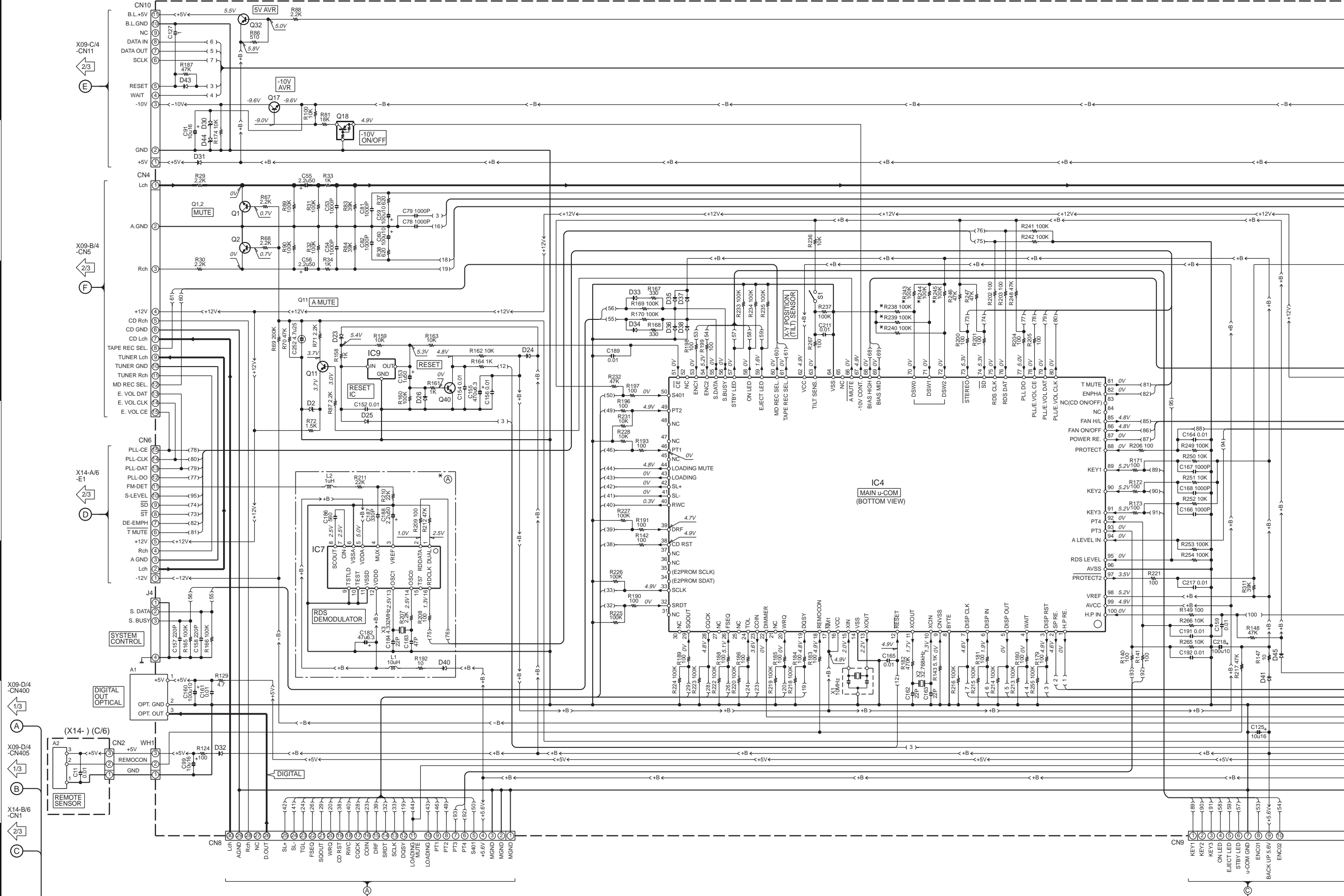

IC4  
MAIN u-COM  
(BOTTOM VIEW)

IC7  
RDS DEMODULATOR

SCOUT 8  
VSTLD 7  
VSSA 6  
TEST 5  
VDDA 4  
VSSD 3  
VDD 2  
VDD 1  
OSC1 13  
OSC2 14  
RDATA 15  
RDCLK DUAL 16

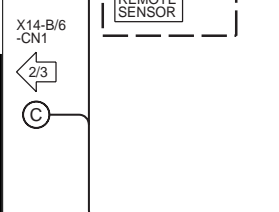
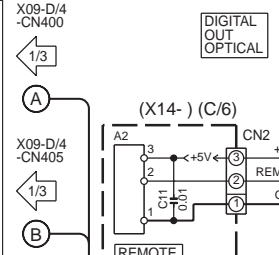
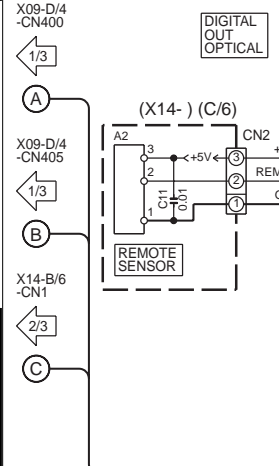

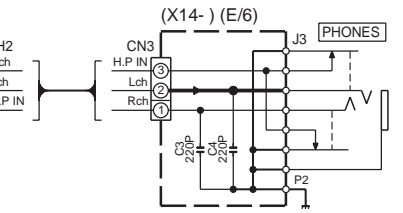
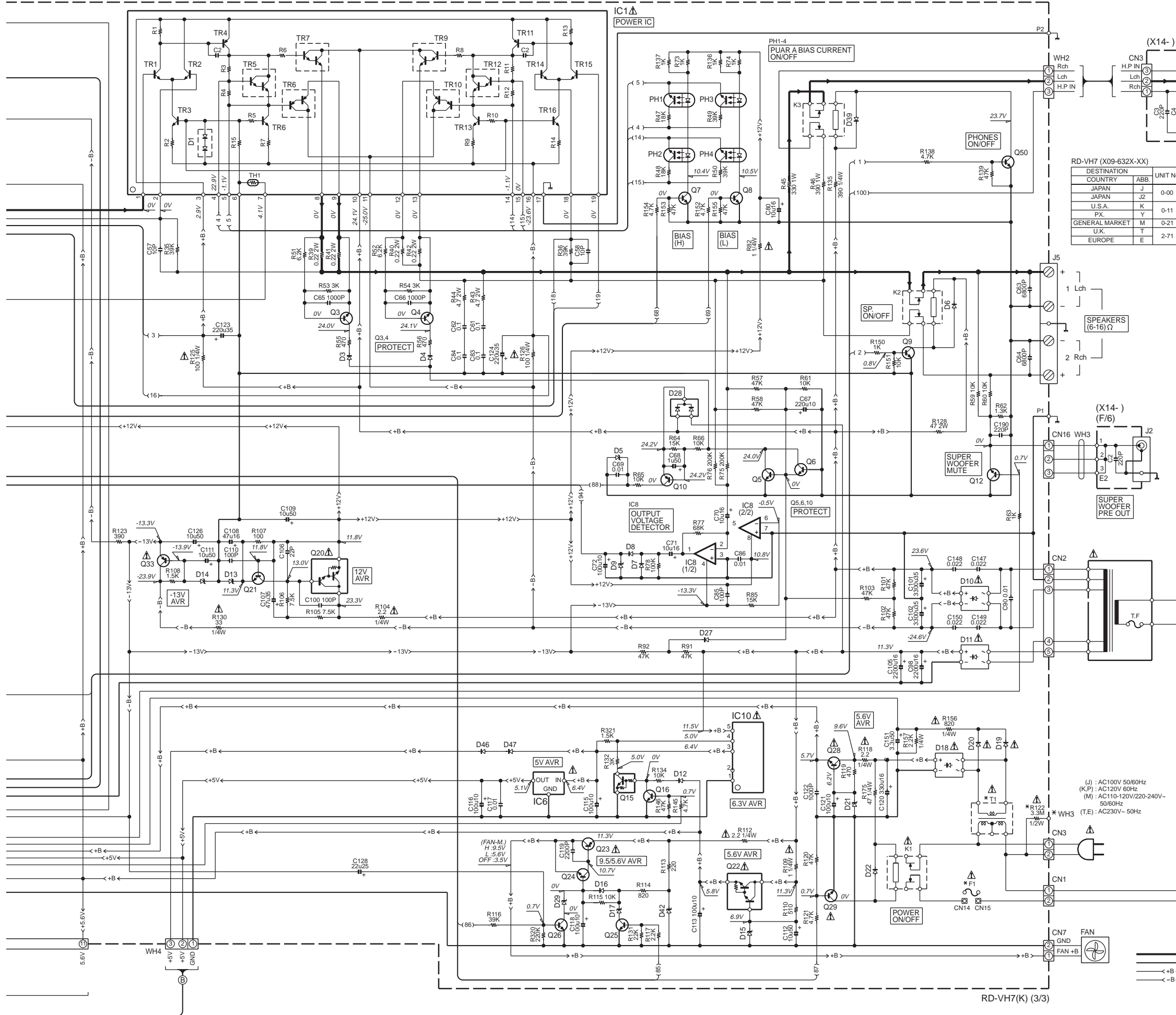

- IC1 : STK499-090
- IC4 : M30622MC-570FP
- IC6 : uPC2905HF
- IC7 : SAA659T/R
- IC8 : NJM4565M
- IC9 : S-806D-Z
- IC10 : SI-3050J

RD-VH7 (X09-632X-XX)

DESTINATION COUNTRY	ABB.	UNIT No.	(A)	R122	R238	R239	R240	R243	R244	R245	WH3	F1	T1
JAPAN	J	0-00		NO	YES	NO	NO	NO	YES	NO	NO	1.25A 125V	L07-2754-05
JAPAN	J2	0-00		NO	YES	NO	NO	NO	NO	NO	NO	1.25A 125V	L07-2755-05
U.S.A.	K	0-11	NO	YES	YES	YES	NO	NO	NO	NO	NO	1.800mA 250V	L07-2756-05
PX.	Y	0-21		NO	NO	NO	NO	NO	NO	NO	NO	1.800mA 250V	L07-2756-05
GENERAL MARKET	M	0-21		NO	NO	NO	NO	NO	NO	NO	NO	1.800mA 250V	L07-2756-05
U.K.	T	2-71	YES	NO	YES	NO	NO	NO	NO	YES	YES	T400mA 250V	L07-2757-05
EUROPE	E	2-71	YES	NO	YES	NO	NO	NO	NO	YES	YES	T400mA 250V	L07-2757-05

- Q1,2,12,26 : 2SC4213(B)
- Q3-6 : 2SC1845(F,E)
- Q7-9,16,17,25,26,40,50 : 2SC4177(L5,L6) or 2SC4116(Y,GR)
- Q10 : 2SA992(F,E)
- Q11,32 : 2SA1576A(S)
- Q15 : UN5219
- Q18 : DTA124EUA or UN5112
- Q20,22 : 2SD2495 x 2
- Q21,24,29 : 2SC1740S(Q,R)
- Q23 : 2SB1640
- Q28 : 2SD2012
- Q33 : 2SB764(E,F)
- D2,29 : UDZ3.9B
- D3,4,6-8,12,16,19,20,22-27,31-41,43,45 : MA111
- D5 : UDZ5.1B
- D9,30,44 : UDZ4.7B
- D10 : D5SBA20F02
- D11 : D2SBA20F03
- D13 : UDZ11B
- D14 : UDZ13B
- D15 : UDZ6.8B
- D17,21 : UDZ6.2B
- D18 : S1ZB20(4101)
- D28 : DAN202U or 1SS301
- D42 : UDZ10B
- D46,47 : S5688
- PH1-4 : T95-0163-05

**CAUTION:** For continued safety, replace safety critical components only with manufacturer's recommended parts (refer to parts list).  $\Delta$  indicates safety critical components. For continued protection against risk of fire, replace only with same type and rating fuse(s). To reduce the risk of electric shock, leakage-current or resistance measurements shall be carried out (exposed parts are acceptably insulated from the supply circuit) before the appliance is returned to the customer.

The DC voltage is an actual reading measured with a high impedance type voltmeter with no signal input. The measurement value may vary depending on the measuring instruments used or on the product.

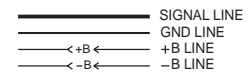

## EXPLODED VIEW (CD MECHANISM)

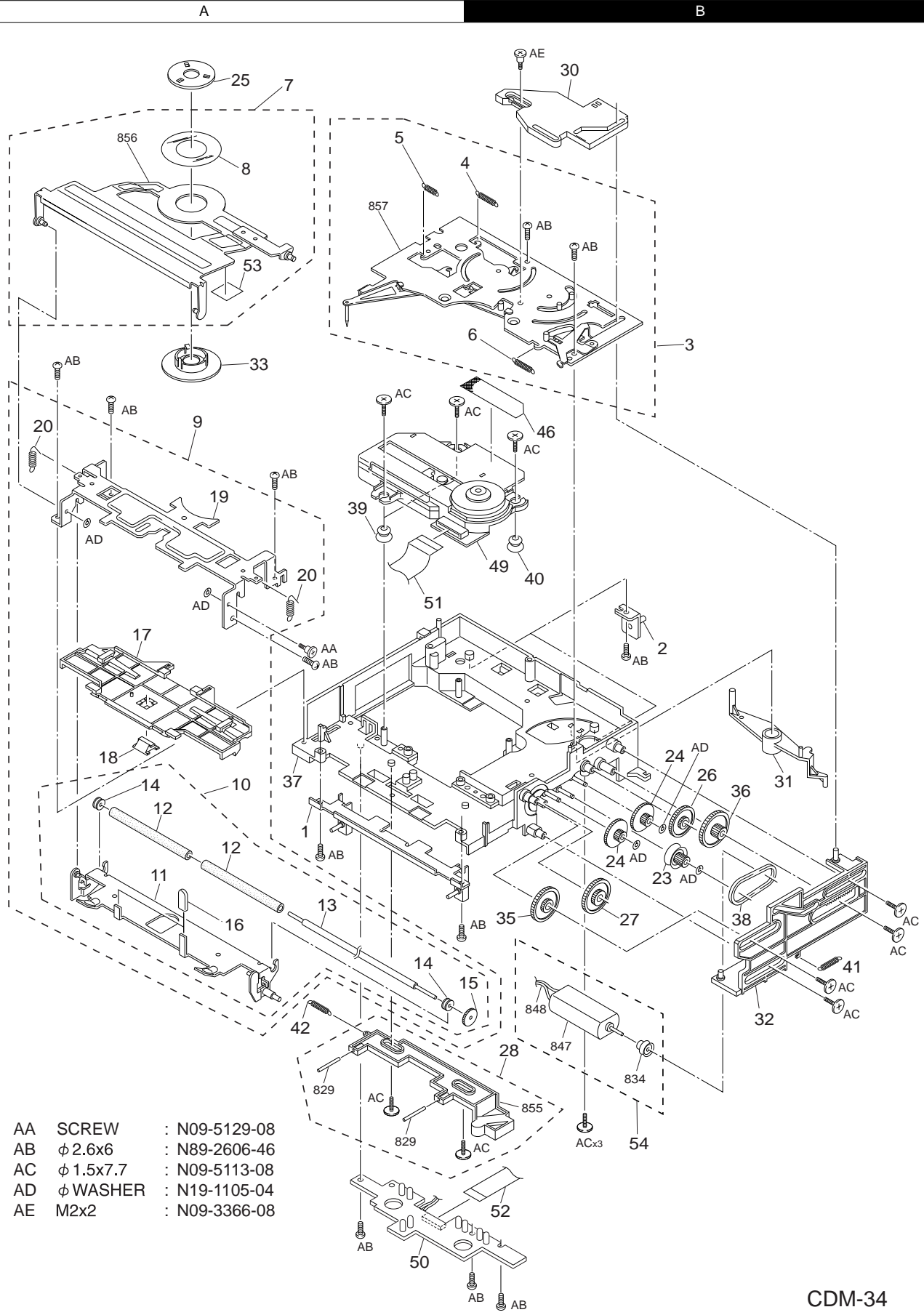

- |    |           |               |
|----|-----------|---------------|
| AA | SCREW     | : N09-5129-08 |
| AB | φ 2.6x6   | : N89-2606-46 |
| AC | φ 1.5x7.7 | : N09-5113-08 |
| AD | φ WASHER  | : N19-1105-04 |
| AE | M2x2      | : N09-3366-08 |

CDM-34

Parts with exploded numbers larger than 700 are not supplied.

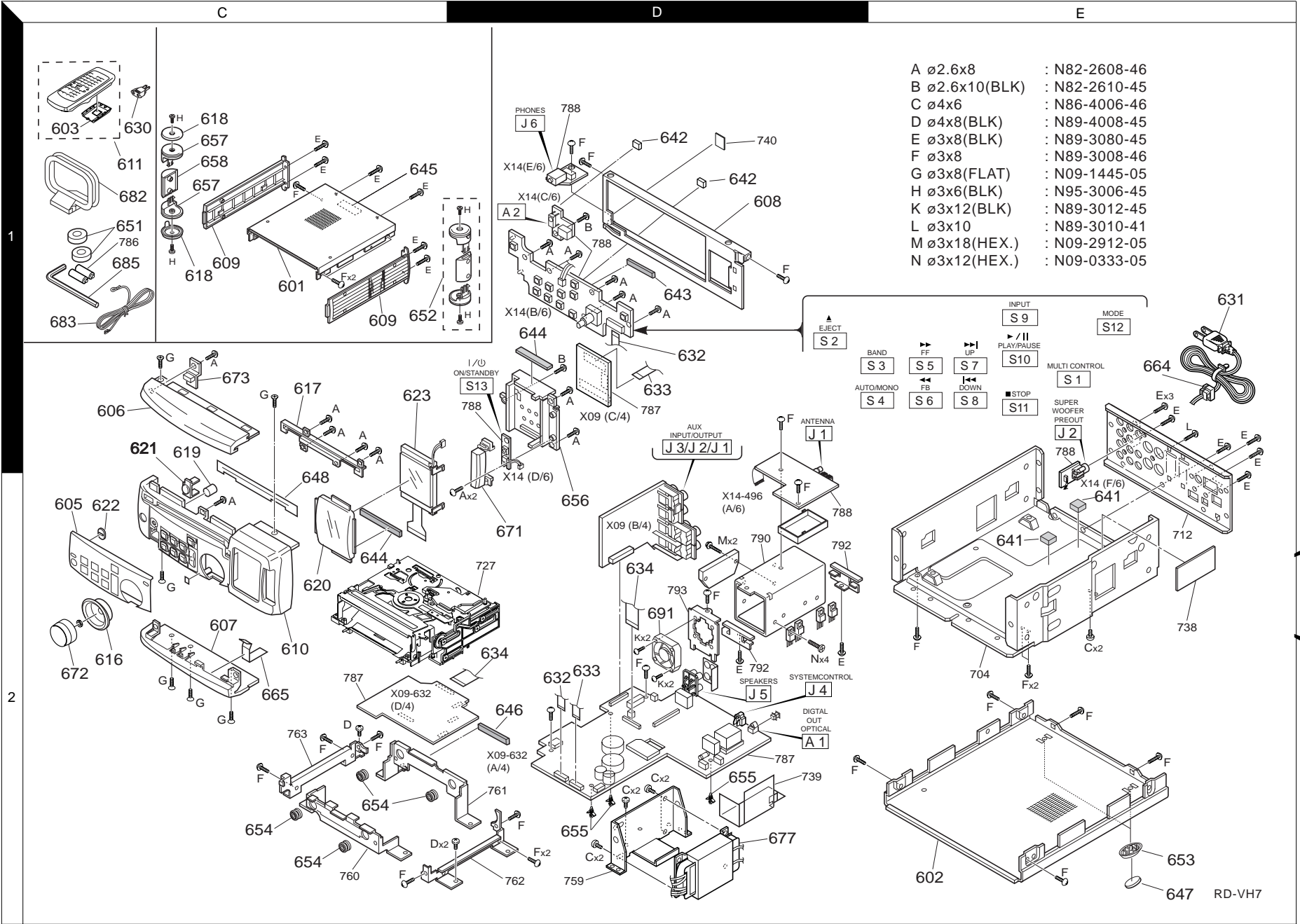

RD-VH7



\* New Parts  
Parts without **Parts No.** are not supplied.  
Les articles non mentionnés dans le **Parts No.** ne sont pas fournis.  
Teile ohne **Parts No.** werden nicht geliefert.

①

Ref. No	Address	New Parts	Parts No.	Description	Destination	Remarks
<b>RD-VH7</b>						
601	1C		A01-3696-01	METALLIC CABINET	KMY TE	
602	2E	*	A01-3697-01	METALLIC CABINET		
603	1C		A09-1148-08	CABINET		
605	2C	*	A21-3759-13	DRESSING PANEL		
605	2C	*	A21-3763-13	DRESSING PANEL		
606	1C	*	A21-3760-02	DRESSING PANEL		
607	2C	*	A21-3761-02	DRESSING PANEL		
608	1D	*	A22-1824-22	SUB PANEL		
609	1C	*	A50-1326-02	SIDE PLATE		
610	2C	*	A60-1647-11	PANEL		
611	1C	*	A70-1282-05	REMOTE CONTROLLER ASSY	KMY TE	
611	1C	*	A70-1283-05	REMOTE CONTROLLER ASSY		
616	2C	*	B07-2452-13	ESCUTCHEON		
617	1C	*	B07-2453-03	ESCUTCHEON		
618	1C		B09-0267-04	CAP		
619	1C		B09-0269-04	CAP		
620	1C		B10-3488-03	FRONT GLASS		
621	1C		B12-0360-04	INDICATOR		
622	1C	*	B12-0364-14	INDICATOR		
623	1C		B38-0180-05	LCD DISPLAY ASSY	TE KY	
-			B46-0310-03	WARRANTY CARD		
-			B46-0328-03	WARRANTY CARD		
-			B46-0346-00	QUESTIONNAIRE CARD	K	
-			B46-0347-03	WARRANTY CARD	K	
-		*	B58-1652-04	CAUTION CARD (120V)	Y	
-		*	B58-1653-04	CAUTION CARD	Y	
-			B59-1104-00	SERVICE DIRECTORY		
-		*	B59-1437-00	SUB-INSTRUCTION MANUAL		
-		*	B60-4280-00	INSTRUCTION MANUAL(EN)	KTY KE E E	
-		*	B60-4283-00	INSTRUCTION MANUAL(FR)		
-		*	B60-4284-00	INSTRUCTION MANUAL(GE)		
-		*	B60-4285-00	INSTRUCTION MANUAL(NE)		
-		*	B60-4286-00	INSTRUCTION MANUAL(IT)	E	
-		*	B60-4287-00	INSTRUCTION MANUAL(ES)	E	
-		*	B60-4288-00	INSTRUCTION MANUAL(TC)	M	
Δ 630	1C		E03-0115-05	AC PLUG ADAPTER	M ME T KY	
Δ 631	1E		E30-2788-05	AC POWER CORD		
Δ 631	1E		E30-2791-05	AC POWER CORD		
Δ 631	1E	*	E30-2924-05	AC POWER CORD		
Δ 632	1D,2D	*	E35-2354-05	FLAT CABLE		
633	1D,2D	*	E35-2379-05	FLAT CABLE		
634	2D	*	E35-2452-05	FLAT CABLE		
638	2E	*	F19-1101-04	SHIELDING PLATE		
641	2E		G11-2350-04	CUSHION		
642	1D		G11-2369-04	CUSHION		
643	1D		G11-2404-04	CUSHION		
644	1D,2C		G11-2272-04	SOFT TAPE		
645	1C	*	G11-2490-04	CUSHION (50X13X6)		
646	2D	*	G11-2495-04	CUSHION		
647	2E	*	G11-2496-04	CUSHION		
648	2C	*	G11-2465-14	CUSHION		

L : Scandinavia K : USA P : Canada R : Mexico C : China I : Malaysia  
Y : PX(Far East, Hawaii) T : Europe E : Europe G : Germany V : China (Shanghai)  
Y : AAFES(Europe) X : Australia Q : Russia H : Korea M : Other Areas Δ indicates safety critical components.

\* New Parts  
Parts without **Parts No.** are not supplied.  
Les articles non mentionnés dans le **Parts No.** ne sont pas fournis.  
Teile ohne **Parts No.** werden nicht geliefert.

②

Ref. No	Address	New Parts	Parts No.	Description	Destination	Remarks
-			H10-7574-02	POLYSTYRENE FOAMED FIXTURE	T M	
-			H10-7575-02	POLYSTYRENE FOAMED FIXTURE		
-			H12-2465-04	PACKING FIXTURE		
-			H20-0576-04	PROTECTION COVER		
-			H25-1595-04	PROTECTION BAG		
-		*	H25-1661-04	PROTECTION BAG	KTE Y	
-		*	H25-1661-04	PROTECTION BAG		
-		*	H30-0610-04	ADHESIVE DOUBLE-COATED TAPE		
-		*	H50-3364-24	ITEM CARTON CASE	KE M	
-		*	H50-3365-14	ITEM CARTON CASE		
-		*	H50-3366-14	ITEM CARTON CASE	T Y	
-		*	H50-3456-04	ITEM CARTON CASE		
651	1C		J02-0130-05	FOOT		
652	1C	*	J02-1444-24	INSULATOR ASSY		
653	2E		J02-1445-04	FOOT		
654	2C	*	J02-1449-04	INSULATOR		
655	2D		J19-5877-05	UNIT HOLDER		
656	2D	*	J19-5976-03	HOLDER		
657	1C	*	J19-5994-14	HOLDER		
658	1C	*	J19-5995-14	HOLDER		
Δ 664	1E		J42-0083-05	POWER CORD BUSHING		
665	2C	*	J69-0097-04	ADHESIVE TAPE		
-			J61-0098-05	WIRE BAND		
671	2D		K29-7554-04	KNOB		
672	2C	*	K29-7556-04	KNOB		
673	1C		K29-7557-03	KNOB	MTE KY	
673	1C		K29-7564-03	KNOB		
Δ 677	2D	*	L07-2723-05	POWER TRANSFORMER	KY M TE	
Δ 677	2D	*	L07-2724-05	POWER TRANSFORMER		
Δ 677	2D	*	L07-2725-05	POWER TRANSFORMER		
682	1C	*	T90-0842-05	LOOP ANTENNA		
683	1C		T90-0841-05	LEAD WIRE ANTENNA		
685	1C		W01-0084-05	HEXAGON WRENCH KEY		
<b>AUDIO UNIT (X09-632X-XX)</b>						
C1 -10			CC73FCH1H470J	CHIP C	47PF	J
C11 -20			CK73FF1C105Z	CHIP C	1.0UF	Z
C21 ,22		*	C92-0088-05	CHIP C	4.7UF	6.3WV
C23 -26			C92-0089-05	CHIP C	10UF	6.3WV
C27 ,28			C92-0023-05	CHIP-ELE	1.0UF	50WV
C29 ,30			C92-0089-05	CHIP C	10UF	6.3WV
C31 ,32		*	C92-0088-05	CHIP C	4.7UF	6.3WV
C35 ,36			C92-0089-05	CHIP C	10UF	6.3WV
C37 ,38		*	C92-0088-05	CHIP C	4.7UF	6.3WV
C39 ,40			CE04KW1C100M	ELECTRO	10UF	16WV
C41 ,42			CF92FV1H824J	MF-C	0.82UF	J
C43 ,44			CK73FB1E333KTA	CHIP C	0.033UF	K
C45 ,46			CF92FV1H474J	MF-C	0.47UF	J
C47 ,48			CK73FB1H183KTA	CHIP C	0.018UF	K
C49 ,50			CK73FB1H223KTA	CHIP C	0.022UF	K
C51			CE04KW1E470M	ELECTRO	47UF	25WV
C52			CE04KW1C470M	ELECTRO	47UF	16WV
C53 ,54			CK73FB1H102K	CHIP C	1000PF	K

L : Scandinavia K : USA P : Canada R : Mexico C : China I : Malaysia  
Y : PX(Far East, Hawaii) T : Europe E : Europe G : Germany V : China (Shanghai)  
Y : AAFES(Europe) X : Australia Q : Russia H : Korea M : Other Areas Δ indicates safety critical components.

PARTS LIST

RD-VH7

\* New Parts  
Parts without **Parts No.** are not supplied.  
Les articles non mentionnés dans le **Parts No.** ne sont pas fournis.  
Teile ohne **Parts No.** werden nicht geliefert.

3

Ref. No	Add-ress	New Parts	Parts No.	Description	Desti-nation	Re-marks
C55,56			CE04KW1H2R2M	ELECTRO	2.2UF	50WV
C57,58			CC73FCH1H100D	CHIP C	10PF	D
C59,60			CE04KW1A101M	ELECTRO	100UF	10WV
C61,62			CQ93FMG1H104J	MYLAR	0.10UF	J
C63,64			CK73FB1H682K	CHIP C	6800PF	K
C65,66			CK73FB1H102K	CHIP C	1000PF	K
C67			CE04KW1A221M	ELECTRO	220UF	10WV
C68			CE04KW1H010M	ELECTRO	1.0UF	50WV
C69			CK73FB1H103K	CHIP C	0.010UF	K
C70,71			CE04KW1C100M	ELECTRO	10UF	16WV
C72			CE04KW1A101M	ELECTRO	100UF	10WV
C73			CK73FB1H103K	CHIP C	0.010UF	K
C75-77			CC73FSL1H101J	CHIP C	100PF	J
C78,79			CK73FB1H102K	CHIP C	1000PF	K
C80			CE04KW1C100M	ELECTRO	10UF	16WV
C81,82			CK73FB1H102K	CHIP C	1000PF	K
C83,84			CQ93FMG1H104J	MYLAR	0.10UF	J
C85			CC73FSL1H101J	CHIP C	100PF	J
C86			CK73FB1H103K	CHIP C	0.010UF	K
C87,88			CC73FSL1H101J	CHIP C	100PF	J
C90			C91-0971-05	FILM	0.01UF	250WV
C91			C92-0037-05	CHIP-ELE	10UF	16WV
C93-96			CC73FSL1H101J	CHIP C	100PF	J
C98		*	C90-3858-05	ELECTRO	2200UF	16WV
C99			CE04KW1C100M	ELECTRO	10UF	16WV
C100			CC73FSL1H101J	CHIP C	100PF	J
C101,102		*	C90-3851-05	ELECTRO	3300UF	35WV
C105		*	C90-3858-05	ELECTRO	2200UF	16WV
C106			CC73FCH1H220J	CHIP C	22PF	J
C107			C90-3303-05	ELECTRO	47UF	35WV
C108			C90-3280-05	ELECTRO	47UF	16WV
C109			CE04KW1H100M	ELECTRO	10UF	50WV
C110			CC73FSL1H101J	CHIP C	100PF	J
C111,112			CE04KW1H100M	ELECTRO	10UF	50WV
C113			C90-3270-05	ELECTRO	100UF	10WV
C115,116			C90-3270-05	ELECTRO	100UF	10WV
C117			CK73FB1H103K	CHIP C	0.010UF	K
C118			CE04KW1A101M	ELECTRO	100UF	10WV
C119			CK73FB1H222K	CHIP C	2200PF	K
C120			CE04KW1C331M	ELECTRO	330UF	16WV
C121			C90-3270-05	ELECTRO	100UF	10WV
C122			CK73FB1H102K	CHIP C	1000PF	K
C123,124		*	C90-3305-05	ELECTRO	220UF	35WV
C125			CE04KW1C100M	ELECTRO	10UF	16WV
C126			CE04KW1H100M	ELECTRO	10UF	50WV
C127			CK73FF1C105Z	CHIP C	1.0UF	Z
C128			C92-0034-05	CHIP-ELE	22UF	25WV
C129-132			CC73FSL1H101J	CHIP C	100PF	J
C133,134			CE04KW1C100M	ELECTRO	10UF	16WV
C135			CK73FB1H103K	CHIP C	0.010UF	K
C147-150			CK73FB1H223KTA	CHIP C	0.022UF	K
C151			CE04KW1H3R3M	ELECTRO	3.3UF	50WV
C152			CK73FB1H103K	CHIP C	0.010UF	K
C153			CE04KW1H010M	ELECTRO	1.0UF	50WV
C154			CK73FB1H103K	CHIP C	0.010UF	K

L : Scandinavia K : USA P : Canada R : Mexico C : China I : Malaysia  
Y : PX(Far East, Hawaii) T : Europe E : Europe G : Germany V : China (Shanghai)  
Y : AAFES(Europe) X : Australia Q : Russia H : Korea M : Other Areas  $\Delta$  indicates safety critical components.

\* New Parts  
Parts without **Parts No.** are not supplied.  
Les articles non mentionnés dans le **Parts No.** ne sont pas fournis.  
Teile ohne **Parts No.** werden nicht geliefert.

4

Ref. No	Add-ress	New Parts	Parts No.	Description	Desti-nation	Re-marks
C155			CE04KW0J471M	ELECTRO	470UF	6.3WV
C156			CK73FB1H103K	CHIP C	0.010UF	K
C157,158			CC73FSL1H221J	CHIP C	220PF	J
C159			CK73FB1H103K	CHIP C	0.010UF	K
C160			CE04KW1A101M	ELECTRO	100UF	10WV
C161			CK73FB1H103K	CHIP C	0.010UF	K
C162,163			CC73FCH1H220J	CHIP C	22PF	J
C164,165			CK73FB1H103K	CHIP C	0.010UF	K
C165-168			CK73FB1H102K	CHIP C	1000PF	K
C182			CE04KW0J470M	ELECTRO	47UF	6.3WV
C183			CC73FCH1H470J	CHIP C	47PF	J
C184			CC73FCH1H220J	CHIP C	22PF	J
C186			CK73FB1H561K	CHIP C	560PF	K
C187			CC73FSL1H331J	CHIP C	330PF	J
C188			CE04KW1H2R2M	ELECTRO	2.2UF	50WV
C189			CK73FB1H103K	CHIP C	0.010UF	K
C190			CC73FSL1H221J	CHIP C	220PF	J
C191,192			CK73FB1H103K	CHIP C	0.010UF	K
C200			CK73FB1E104K	CHIP C	0.10UF	K
C201-203			CK73FB1H103K	CHIP C	0.010UF	K
C204			CK73FB1H102K	CHIP C	1000PF	K
C205			CE04KW1C100M	ELECTRO	10UF	16WV
C206			CK73FB1H471K	CHIP C	470PF	K
C207			CK73FB1E104K	CHIP C	0.10UF	K
C208			CK73FF1C105Z	CHIP C	1.0UF	Z
C209,210			CK73FB1H471K	CHIP C	470PF	K
C211			CK73FB1H103K	CHIP C	0.010UF	K
C212-216			CK73FF1E474Z	CHIP C	4.7UF	Z
C217			CK73FB1H103K	CHIP C	0.010UF	K
C218			CE04KW1A101M	ELECTRO	100UF	10WV
C219-228			CC73FSL1H221J	CHIP C	220PF	J
C252			CE04HW1E4R7M	NP-ELEC	4.7UF	25WV
C400			CK73FB1C224K	CHIP C	0.22UF	K
C401			CC73FSL1H331J	CHIP C	330PF	J
C402			CK73FB1H333K	CHIP C	0.033UF	K
C403			CK73FB1H103K	CHIP C	0.010UF	K
C404			CK73FB1E104K	CHIP C	0.10UF	K
C405			CK73FB1C224K	CHIP C	0.22UF	K
C406			CK73FB1H102K	CHIP C	1000PF	K
C407			CK73FB1H473K	CHIP C	0.047UF	K
C408			CK73FB1C154K	CHIP C	0.15UF	K
C409			CK73FB1H102K	CHIP C	1000PF	K
C410			CK73FF1C105Z	CHIP C	1.0UF	Z
C411			CK73FB1E104K	CHIP C	0.10UF	K
C412			CK73FB1H153K	CHIP C	0.015UF	K
C413			CC73FSL1H221J	CHIP C	220PF	J
C415			CK73FB1H123K	CHIP C	0.012UF	K
C416			CK73FB1C474K	CHIP C	0.47UF	K
C417			CC73FSL1H471J	CHIP C	470PF	J
C418			CK73FB1H103K	CHIP C	0.010UF	K
C419			C92-0090-05	CHIP C	22UF	6.3WV
C420			CK73FB1H332K	CHIP C	3300PF	K
C421			CC73FSL1H331J	CHIP C	330PF	J
C422		*	C92-0209-05	CHIP C	4.7UF	16WV
C423,424			C92-0093-05	CHIP C	100UF	6.3WV

L : Scandinavia K : USA P : Canada R : Mexico C : China I : Malaysia  
Y : PX(Far East, Hawaii) T : Europe E : Europe G : Germany V : China (Shanghai)  
Y : AAFES(Europe) X : Australia Q : Russia H : Korea M : Other Areas  $\Delta$  indicates safety critical components.

\* New Parts  
Parts without **Parts No.** are not supplied.  
Les articles non mentionnés dans le **Parts No.** ne sont pas fournis.  
Teile ohne **Parts No.** werden nicht geliefert.

5

Ref. No	Add-ress	New Parts	Parts No.	Description	Desti-nation	Re-marks
C425			C92-0089-05	CHIP C 10UF 6.3WV		
C426			CK73FB1H473K	CHIP C 0.047UF K		
C427			CK73FB1E104K	CHIP C 0.10UF K		
C428			CK73FB1H683K	CHIP C 0.068UF K		
C429			C92-0093-05	CHIP C 100UF 6.3WV		
C430			CK73FB1H103K	CHIP C 0.010UF K		
C431			CC73FCH1H120J	CHIP C 12PF J		
C433			CK73FB1H102K	CHIP C 1000PF K		
C434			CK73FB1H333K	CHIP C 0.033UF K		
C435			C92-0093-05	CHIP C 100UF 6.3WV		
C437,438			CK73FB1E104K	CHIP C 0.10UF K		
C442			CK73FB1E104K	CHIP C 0.10UF K		
C443			CC73FCH1H060D	CHIP C 6.0PF D		
C445			C92-0093-05	CHIP C 100UF 6.3WV		
C451,452			CK73FB1H102K	CHIP C 1000PF K		
C453,454			CC73FSL1H181J	CHIP C 180PF J		
C455,456			CK73FB1H392K	CHIP C 3900PF K		
C457,458			CC73FSL1H101J	CHIP C 100PF J		
C459,460			CC73FSL1H181J	CHIP C 180PF J		
C461,462			CC73FSL1H101J	CHIP C 100PF J		
C463,464			CC73FSL1H471J	CHIP C 470PF J		
C465			CK73FB1H103K	CHIP C 0.010UF K		
C466			C92-0093-05	CHIP C 100UF 6.3WV		
C469			C92-0093-05	CHIP C 100UF 6.3WV		
C471			CK73FB1C224K	CHIP C 0.22UF K		
C472			C92-0089-05	CHIP C 10UF 6.3WV		
C473			CK73FB1H102K	CHIP C 1000PF K		
C474			CK73FB1E104K	CHIP C 0.10UF K		
C480			CE04DW1C471M	ELECTRO 470UF 16WV		
C499			CC73FSL1H121J	CHIP C 120PF J		
C500			CC73FSL1H470J	CHIP C 47PF J		
C502			CK73FF1C105Z	CHIP C 1.0UF Z		
CN1			E40-4245-05	PIN ASSY		
CN2			E40-3240-05	PIN ASSY		
CN3			E40-4245-05	PIN ASSY		
CN4			E40-9848-05	PIN ASSY		
CN5			E40-9831-05	SOCKET FOR PIN ASSY		
CN6			E40-4609-05	PIN ASSY		
CN7			E40-3246-05	PIN ASSY		
CN8		*	E40-8465-05	FLAT CABLE CONNECTOR		
CN9			E40-4898-05	FLAT CABLE CONNECTOR		
CN10		*	E40-8466-05	FLAT CABLE CONNECTOR		
CN11			E40-4151-05	FLAT CABLE CONNECTOR		
CN12			E40-8200-05	FLAT CABLE CONNECTOR		
CN13			E40-3246-05	PIN ASSY		
CN16			E40-4293-05	FLAT CABLE CONNECTOR		
CN400		*	E40-8464-05	FLAT CABLE CONNECTOR		
CN401		*	E40-8406-05	FLAT CABLE CONNECTOR		
CN402			E40-3251-05	PIN ASSY		
CN403		*	E40-8395-05	FLAT CABLE CONNECTOR		
CN404		*	E40-8399-05	PIN ASSY		
CN405			E40-3261-05	PIN ASSY		
J1		*	E63-1088-05	PHONO JACK (3P RED)		
J2		*	E63-1089-05	PHONO JACK (3P WHT)		

L : Scandinavia K : USA P : Canada R : Mexico C : China I : Malaysia  
Y : PX(Far East, Hawaii) T : Europe E : Europe G : Germany V : China (Shanghai)  
Y : AAFES(Europe) X : Australia Q : Russia H : Korea M : Other Areas  $\Delta$  indicates safety critical components.

\* New Parts  
Parts without **Parts No.** are not supplied.  
Les articles non mentionnés dans le **Parts No.** ne sont pas fournis.  
Teile ohne **Parts No.** werden nicht geliefert.

6

Ref. No	Add-ress	New Parts	Parts No.	Description	Desti-nation	Re-marks
J3		*	E63-1082-05	PHONO JACK		
J4			E08-0311-05	RECTANGULAR RECEPTACLE		
J5		*	E70-0111-05	SCREW TERMINAL BOARD		
P1			E29-1625-04	LEAD PLATE		
691	2D	*	F09-0142-05	FAN		
$\Delta$ F1			F05-4016-05	FUSE (SEMKO) (250V T400MAL)	TE	
$\Delta$ F1			F05-8013-05	FUSE (SEMKO) (250V T800MAL)	M	
$\Delta$ F1			F50-0067-05	FUSE(5X20)	KY	
-		*	J19-6006-14	HOLDER		
CN14,15			J13-0075-05	FUSE CLIP		
CN14,15			J13-0092-05	FUSE CLIP		
E1			J11-0808-05	WIRE CLAMPER		
L1			L40-1001-31	SMALL FIXED INDUCTOR(10UH,K) TE		
L2			L40-1091-31	SMALL FIXED INDUCTOR(1UH,K) TE		
$\Delta$ T1		*	L07-2755-05	POWER TRANSFORMER	KY	
$\Delta$ T1		*	L07-2756-05	POWER TRANSFORMER	M	
$\Delta$ T1		*	L07-2757-05	POWER TRANSFORMER	TE	
X1			L78-0294-05	RESONATOR (10.000M)		
X2		*	L77-2256-05	CRYSTAL RESONATOR(32.768KHZ)		
X3		*	L77-2255-05	CRYSTAL RESONATOR(4.332MHZ)		
X4			L78-0696-05	RESONATOR (16.000MHZ)		
X400		*	L77-2257-05	CRYSTAL RESONATOR(16.9344MHZ)		
R1 -10			RK73FB2A101J	CHIP R 100 J 1/10W		
R11 -20			RK73FB2A104J	CHIP R 100K J 1/10W		
R21 ,22			RK73FB2A101J	CHIP R 100 J 1/10W		
R23 -28			RK73FB2A103J	CHIP R 10K J 1/10W		
R29 ,30			RK73FB2A222J	CHIP R 2.2K J 1/10W		
R31 ,32			RK73FB2A104J	CHIP R 100K J 1/10W		
R33 ,34			RK73FB2A102J	CHIP R 1.0K J 1/10W		
R35 ,36			RK73FB2A393J	CHIP R 39K J 1/10W		
R37 ,38			RK73FB2A621J	CHIP R 620 J 1/10W		
R39 -42			RS14KB3DR22J	FL-PROOF RS 0.22 J 2W		
R43 ,44			RS14KB3D4R7J	FL-PROOF RS 4.7 J 2W		
R45 ,46			RS14KB3A331J	FL-PROOF RS 330 J 1W		
R47 ,48			RK73FB2A183J	CHIP R 18K J 1/10W		
R49 ,50			RK73FB2A393J	CHIP R 39K J 1/10W		
R51 ,52			RK73FB2A622J	CHIP R 6.2K J 1/10W		
R53 ,54			RK73FB2A302J	CHIP R 3.0K J 1/10W		
R55 ,56			RK73FB2A471J	CHIP R 470 J 1/10W		
R57 ,58			RK73FB2A473J	CHIP R 47K J 1/10W		
R59 -61			RK73FB2A103J	CHIP R 10K J 1/10W		
R62			RK73FB2A132J	CHIP R 1.3K J 1/10W		
R63			RK73FB2A102J	CHIP R 1.0K J 1/10W		
R64			RK73FB2A153J	CHIP R 15K J 1/10W		
R65 ,66			RK73FB2A103J	CHIP R 10K J 1/10W		
R67 ,68			RK73FB2A222J	CHIP R 2.2K J 1/10W		
R69			RK73FB2A204J	CHIP R 200K J 1/10W		
R70			RK73FB2A473J	CHIP R 47K J 1/10W		
R71			RK73FB2A222J	CHIP R 2.2K J 1/10W		
R72			RK73FB2A152J	CHIP R 1.5K J 1/10W		
R73 ,74			RK73FB2A102J	CHIP R 1.0K J 1/10W		
R75 ,76			RK73FB2A204J	CHIP R 200K J 1/10W		
R77			RK73FB2A683J	CHIP R 68K J 1/10W		
R78			RK73FB2A104J	CHIP R 100K J 1/10W		

L : Scandinavia K : USA P : Canada R : Mexico C : China I : Malaysia  
Y : PX(Far East, Hawaii) T : Europe E : Europe G : Germany V : China (Shanghai)  
Y : AAFES(Europe) X : Australia Q : Russia H : Korea M : Other Areas  $\Delta$  indicates safety critical components.

PARTS LIST

RD-VH7

\* New Parts  
Parts without **Parts No.** are not supplied.  
Les articles non mentionnés dans le **Parts No.** ne sont pas fournis.  
Teile ohne **Parts No.** werden nicht geliefert.



Ref. No	Add-ress	New Parts	Parts No.	Description	Desti-nation	Re-marks
R79_80			RK73FB2A123J	CHIP R 12K J 1/10W		
R81			RK73FB2A183J	CHIP R 18K J 1/10W		
R82			RD14NB2E1R0J	RD 1 J 1/4W		
R83_84			RK73FB2A393J	CHIP R 39K J 1/10W		
R85			RK73FB2A153J	CHIP R 15K J 1/10W		
R86			RK73FB2A511J	CHIP R 510 J 1/10W		
R87_88			RK73FB2A222J	CHIP R 2.2K J 1/10W		
R89_90			RK73FB2A104J	CHIP R 100K J 1/10W		
R91_92			RK73FB2A473J	CHIP R 47K J 1/10W		
R93_94			RK73FB2A101J	CHIP R 100 J 1/10W		
R100			RK73FB2A103J	CHIP R 10K J 1/10W		
R101-103			RK73FB2A473J	CHIP R 47K J 1/10W		
R104			RD14NB2E2R2J	RD 2.2 J 1/4W		
R105,106			RK73FB2A752J	CHIP R 7.5K J 1/10W		
R107			RK73FB2A101J	CHIP R 100 J 1/10W		
R108			RK73FB2A152J	CHIP R 1.5K J 1/10W		
R109			RD14NB2E1R0J	RD 1 J 1/4W		
R110			RK73FB2A511J	CHIP R 510 J 1/10W		
R111		*	R92-1922-05	METAL FILM 0.22 J 1/2W		
R112			RD14NB2E2R2J	RD 2.2 J 1/4W		
R113			RK73FB2A221J	CHIP R 220 J 1/10W		
R114			RK73FB2A821J	CHIP R 820 J 1/10W		
R115			RK73FB2A103J	CHIP R 10K J 1/10W		
R116			RK73FB2A393J	CHIP R 39K J 1/10W		
R117			RK73FB2A222J	CHIP R 2.2K J 1/10W		
R118			RD14NB2E2R2J	RD 2.2 J 1/4W		
R119			RK73FB2A471J	CHIP R 470 J 1/10W		
R120			RK73FB2A473J	CHIP R 47K J 1/10W		
R121			RK73FB2A472J	CHIP R 4.7K J 1/10W		
R122			R92-1844-05	CARBON 3.3M J 1/2W	KY	
R123			RK73FB2A391J	CHIP R 390 J 1/10W		
R124			RK73FB2A101J	CHIP R 100 J 1/10W		
R125,126			RD14NB2E101J	RD 100 J 1/4W		
R127			RD14NB2E220J	RD 22 J 1/4W		
R128			RS14KB3D470J	FL-PROOF RS 47 J 2W		
R129			RK73FB2A4R7J	CHIP R 4.7 J 1/10W		
R130			RD14NB2E330J	RD 33 J 1/4W		
R131			RK73FB2A223J	CHIP R 22K J 1/10W		
R132			RK73FB2A113J	CHIP R 11K J 1/10W		
R134			RK73FB2A103J	CHIP R 10K J 1/10W		
R135			RD14NB2E391J	RD 390 J 1/4W		
R136,137			RK73FB2A102J	CHIP R 1.0K J 1/10W		
R138			RK73FB2A472J	CHIP R 4.7K J 1/10W		
R139			RK73FB2A473J	CHIP R 47K J 1/10W		
R140-142			RK73FB2A101J	CHIP R 100 J 1/10W		
R143			RK73FB2A512J	CHIP R 5.1K J 1/10W		
R144			RK73FB2A753J	CHIP R 75K J 1/10W		
R145			RK73FB2A472J	CHIP R 4.7K J 1/10W		
R146			RK73FB2A473J	CHIP R 47K J 1/10W		
R147			RK73FB2A100J	CHIP R 10 J 1/10W		
R148			RK73FB2A473J	CHIP R 47K J 1/10W		
R149			RK73FB2A101J	CHIP R 100 J 1/10W		
R150			RK73FB2A102J	CHIP R 1.0K J 1/10W		
R151			RK73FB2A103J	CHIP R 10K J 1/10W		
R152			RK73FB2A472J	CHIP R 4.7K J 1/10W		

L : Scandinavia K : USA P : Canada R : Mexico C : China I : Malaysia  
Y : PX(Far East, Hawaii) T : Europe E : Europe G : Germany V : China (Shanghai)  
Y : AAFES(Europe) X : Australia Q : Russia H : Korea M : Other Areas Δ indicates safety critical components.

PARTS LIST



\* New Parts  
Parts without **Parts No.** are not supplied.  
Les articles non mentionnés dans le **Parts No.** ne sont pas fournis.  
Teile ohne **Parts No.** werden nicht geliefert.

Ref. No	Add-ress	New Parts	Parts No.	Description	Desti-nation	Re-marks
R153			RK73FB2A473J	CHIP R 47K J 1/10W		
R154			RK73FB2A472J	CHIP R 4.7K J 1/10W		
R155			RK73FB2A473J	CHIP R 47K J 1/10W		
R156			RD14NB2E821J	RD 820 J 1/4W		
R157			RD14NB2E222J	RD 2.2K J 1/4W		
R158			RK73FB2A102J	CHIP R 1.0K J 1/10W		
R159			RK73FB2A103J	CHIP R 10K J 1/10W		
R160			RK73FB2A104J	CHIP R 100K J 1/10W		
R161			RK73FB2A102J	CHIP R 1.0K J 1/10W		
R162,163			RK73FB2A103J	CHIP R 10K J 1/10W		
R164			RK73FB2A102J	CHIP R 1.0K J 1/10W		
R165,166			RK73FB2A104J	CHIP R 100K J 1/10W		
R167,168			RK73FB2A331J	CHIP R 330 J 1/10W		
R169,170			RK73FB2A104J	CHIP R 100K J 1/10W		
R171-173			RK73FB2A101J	CHIP R 100 J 1/10W		
R174			RK73FB2A103J	CHIP R 10K J 1/10W		
R175			RD14NB2E470J	RD 47 J 1/4W		
R176-178			RK73FB2A102J	CHIP R 1.0K J 1/8W		
R179-181			RK73FB2A101J	CHIP R 100 J 1/10W		
R182			RK73FB2A474J	CHIP R 470K J 1/10W		
R183-186			RK73FB2A101J	CHIP R 100 J 1/10W		
R187			RK73FB2A473J	CHIP R 47K J 1/10W		
R188-191			RK73FB2A101J	CHIP R 100 J 1/10W		
R192			RK73FB2A100J	CHIP R 10 J 1/10W	TE	
R193			RK73FB2A101J	CHIP R 100 J 1/10W		
R196-206			RK73FB2A101J	CHIP R 100 J 1/10W		
R207			RK73FB2A222J	CHIP R 2.2K J 1/10W	TE	
R208,209			RK73FB2A101J	CHIP R 100 J 1/10W	TE	
R210,211			RK73FB2A223J	CHIP R 22K J 1/10W	TE	
R212			RK73FB2A473J	CHIP R 47K J 1/10W	TE	
R213-216			RK73FB2A104J	CHIP R 100K J 1/10W		
R217			RK73FB2A473J	CHIP R 47K J 1/10W		
R218-220			RK73FB2A104J	CHIP R 100K J 1/10W		
R221			RK73FB2A101J	CHIP R 100 J 1/10W		
R222-227			RK73FB2A104J	CHIP R 100K J 1/10W		
R228			RK73FB2A103J	CHIP R 10K J 1/10W		
R229			RK73FB2A101J	CHIP R 100 J 1/10W		
R231			RK73FB2A103J	CHIP R 10K J 1/10W		
R232			RK73FB2A473J	CHIP R 47K J 1/10W		
R233-235			RK73FB2A104J	CHIP R 100K J 1/10W		
R236			RK73FB2A103J	CHIP R 10K J 1/10W		
R237			RK73FB2A104J	CHIP R 100K J 1/10W		
R238			RK73FB2A104J	CHIP R 100K J 1/10W	KYTE	
R239			RK73FB2A104J	CHIP R 100K J 1/10W	KYM	
R240			RK73FB2A104J	CHIP R 100K J 1/10W	KY	
R241,242			RK73FB2A104J	CHIP R 100K J 1/10W		
R243			RK73FB2A104J	CHIP R 100K J 1/10W	M	
R244,245			RK73FB2A104J	CHIP R 100K J 1/10W	TE	
R246-248			RK73FB2A473J	CHIP R 47K J 1/10W		
R249			RK73FB2A104J	CHIP R 100K J 1/10W		
R250-252			RK73FB2A103J	CHIP R 10K J 1/10W		
R253-255			RK73FB2A104J	CHIP R 100K J 1/10W		
R260			RK73FB2A4R7J	CHIP R 4.7 J 1/10W		
R261			RK73FB2A101J	CHIP R 100 J 1/10W		
R262-264			RK73FB2A473J	CHIP R 47K J 1/10W		

L : Scandinavia K : USA P : Canada R : Mexico C : China I : Malaysia  
Y : PX(Far East, Hawaii) T : Europe E : Europe G : Germany V : China (Shanghai)  
Y : AAFES(Europe) X : Australia Q : Russia H : Korea M : Other Areas Δ indicates safety critical components.

\* New Parts

Parts without **Parts No.** are not supplied.  
Les articles non mentionnés dans le **Parts No.** ne sont pas fournis.  
Teile ohne **Parts No.** werden nicht geliefert.

9

Ref. No	Add-ress	New Parts	Parts No.	Description	Desti-nation	Re-marks
R265,266			RK73FB2A103J	CHIP R 10K J 1/10W		
R267			RK73FB2A101J	CHIP R 100 J 1/10W		
R289			RK73FB2A753J	CHIP R 75K J 1/10W		
R290			RK73FB2A333J	CHIP R 33K J 1/10W		
R291			RK73FB2A104J	CHIP R 100K J 1/10W		
R292-294			RK73FB2A101J	CHIP R 100 J 1/10W		
R295			RK73FB2A473J	CHIP R 47K J 1/10W		
R297-304			RK73FB2A101J	CHIP R 100 J 1/10W		
R310			RK73FB2A103J	CHIP R 10K J 1/10W		
R311			RK73FB2A393J	CHIP R 39K J 1/10W		
R320			RK73FB2A224J	CHIP R 220K J 1/10W		
R321			RK73FB2A152J	CHIP R 1.5K J 1/10W		
R400-405			RK73FB2A473J	CHIP R 47K J 1/10W		
R406			RK73FB2A101J	CHIP R 100 J 1/10W		
R407			RK73FB2A104J	CHIP R 100K J 1/10W		
R408			RK73FB2A222J	CHIP R 2.2K J 1/10W		
R409			RK73FB2A472J	CHIP R 4.7K J 1/10W		
R410			RK73FB2A102J	CHIP R 1.0K J 1/10W		
R411			RK73FB2A273J	CHIP R 27K J 1/10W		
R412			RK73FB2A561J	CHIP R 560 J 1/10W		
R413			RK73FB2A104J	CHIP R 100K J 1/10W		
R414			RK73FB2A103J	CHIP R 10K J 1/10W		
R415			RK73FB2A392J	CHIP R 3.9K J 1/10W		
R416			RK73FB2A682J	CHIP R 6.8K J 1/10W		
R417			RK73FB2A472J	CHIP R 4.7K J 1/10W		
R418			RK73FB2A223J	CHIP R 22K J 1/10W		
R419			RK73FB2A103J	CHIP R 10K J 1/10W		
R420			RK73FB2A272J	CHIP R 2.7K J 1/10W		
R421			RK73FB2A101J	CHIP R 100 J 1/10W		
R422			RK73FB2A223J	CHIP R 22K J 1/10W		
R425,426			RK73FB2A102J	CHIP R 1.0K J 1/10W		
R427			RK73FB2A473J	CHIP R 47K J 1/10W		
R428			RK73FB2A393J	CHIP R 39K J 1/10W		
R429			RK73FB2A473J	CHIP R 47K J 1/10W		
R430			RK73FB2A563J	CHIP R 56K J 1/10W		
R431			RK73FB2A222J	CHIP R 2.2K J 1/10W		
R432			RK73FB2A225J	CHIP R 2.2M J 1/10W		
R433			RK73FB2A563J	CHIP R 56K J 1/10W		
R434			RK73FB2A104J	CHIP R 100K J 1/10W		
R435			RK73FB2A123J	CHIP R 12K J 1/10W		
R436,437			RK73FB2A224J	CHIP R 220K J 1/10W		
R438			RK73FB2A333J	CHIP R 33K J 1/10W		
R439			RK73FB2A2R2J	CHIP R 2.2 J 1/10W		
R440			RK73FB2A100J	CHIP R 10 J 1/10W		
R441			RK73FB2A331J	CHIP R 330 J 1/10W		
R442			RK73FB2A123J	CHIP R 12K J 1/10W		
R443			RK73FB2A473J	CHIP R 47K J 1/10W		
R444			RK73FB2A331J	CHIP R 330 J 1/10W		
R445			RK73FB2A153J	CHIP R 15K J 1/10W		
R446			RK73FB2A2R2J	CHIP R 2.2 J 1/10W		
R448			RK73FB2A103J	CHIP R 10K J 1/10W		
R449			RK73FB2A105J	CHIP R 1.0M J 1/10W		
R450			RK73FB2A2R2J	CHIP R 2.2 J 1/10W		
R451			RK73FB2A471J	CHIP R 470 J 1/10W		
R452			RK73FB2A152J	CHIP R 1.5K J 1/10W		

L : Scandinavia K : USA P : Canada R : Mexico C : China I : Malaysia  
Y : PX(Far East, Hawaii) T : Europe E : Europe G : Germany V : China (Shanghai)  
Y : AAFES(Europe) X : Australia Q : Russia H : Korea M : Other Areas Δ indicates safety critical components.

\* New Parts

Parts without **Parts No.** are not supplied.  
Les articles non mentionnés dans le **Parts No.** ne sont pas fournis.  
Teile ohne **Parts No.** werden nicht geliefert.

10

Ref. No	Add-ress	New Parts	Parts No.	Description	Desti-nation	Re-marks
R453			RK73FB2A104J	CHIP R 100K J 1/10W		
R454			RK73FB2A681J	CHIP R 680 J 1/10W		
R455			RK73FB2A513J	CHIP R 51K J 1/10W		
R456			RK73FB2A122J	CHIP R 1.2K J 1/10W		
R457			RK73FB2A333J	CHIP R 33K J 1/10W		
R461-464			RK73FB2A472J	CHIP R 4.7K J 1/10W		
R465-468			RK73FB2A562J	CHIP R 5.6K J 1/10W		
R469,470			RK73FB2A113J	CHIP R 11K J 1/10W		
R471-474			RK73FB2A302J	CHIP R 3.0K J 1/10W		
R475,476			RK73FB2A113J	CHIP R 11K J 1/10W		
R477,478			RK73FB2A101J	CHIP R 100 J 1/10W		
R479			RK73FB2A393J	CHIP R 39K J 1/10W		
R481,482			RK73FB2A302J	CHIP R 3.0K J 1/10W		
R483			RK73FB2A2R2J	CHIP R 2.2 J 1/10W		
R484			RK73FB2A163J	CHIP R 16K J 1/10W		
R485			RK73FB2A103J	CHIP R 10K J 1/10W		
R487			RK73FB2A562J	CHIP R 5.6K J 1/10W		
R488			RK73FB2A223J	CHIP R 22K J 1/10W		
R489			RK73FB2A103J	CHIP R 10K J 1/10W		
R490			RK73FB2A332J	CHIP R 3.3K J 1/10W		
R491			RK73FB2A224J	CHIP R 220K J 1/10W		
R492			R92-1867-05	METAL 12K F 1/10W		
R493			RK73FB2A182J	CHIP R 1.8K J 1/10W		
R494			RK73FB2A103J	CHIP R 10K J 1/10W		
R495			R92-1915-05	METAL GLAZE 4.12K F 1/10W		
R496			R92-1839-05	CHIP R 1.5K F 1/10W		
R497			RK73FB2A103J	CHIP R 10K J 1/10W		
R498			RK73FB2A333J	CHIP R 33K J 1/10W		
R500			RK73FB2A512J	CHIP R 5.1K J 1/10W		
R501			RK73FB2A101J	CHIP R 100 J 1/10W		
R502			RK73FB2A1R0J	CHIP R 1 J 1/10W		
R503-506			RK73FB2A103J	CHIP R 10K J 1/10W		
R507-510			RK73FB2A101J	CHIP R 100 J 1/10W		
R511-514			RK73FB2A153J	CHIP R 15K J 1/10W		
R515			RK73FB2A473J	CHIP R 47K J 1/10W		
R516,517			RK73FB2A153J	CHIP R 15K J 1/10W		
R519			RK73FB2A105J	CHIP R 1.0M J 1/10W		
R520,521			RK73FB2A224J	CHIP R 220K J 1/10W		
R522			RK73FB2A473J	CHIP R 47K J 1/10W		
R523			RK73FB2A103J	CHIP R 10K J 1/10W		
R530			RK73FB2A910J	CHIP R 91 J 1/10W		
R537			RK73FB2A104J	CHIP R 100K J 1/10W		
VR400,401			R32-0040-05	SEMI FIXED VARIABLE RESISTOR		
W6 ,7			R92-0670-05	CHIP R 0 OHM		
Δ K1			S76-0091-05	MAGNETIC RELAY		
K2		*	S76-0092-05	MAGNETIC RELAY		
K3			S76-0027-05	MAGNETIC RELAY		
S1			S90-0129-05	SWITCH COMPONENT		
PH1 -4		*	T95-0163-05	OPTO ISOLATOR		
D1			UDZ10B	ZENER DIODE		
D2			UDZ3.9B	ZENER DIODE		
D3 ,4			MA111	DIODE		
D5			UDZ5.1B	ZENER DIODE		
D6 -8			MA111	DIODE		

L : Scandinavia K : USA P : Canada R : Mexico C : China I : Malaysia  
Y : PX(Far East, Hawaii) T : Europe E : Europe G : Germany V : China (Shanghai)  
Y : AAFES(Europe) X : Australia Q : Russia H : Korea M : Other Areas Δ indicates safety critical components.

PARTS LIST

RD-VH7

\* New Parts

Parts without **Parts No.** are not supplied.  
 Les articles non mentionnés dans le **Parts No.** ne sont pas fournis.  
 Teile ohne **Parts No.** werden nicht geliefert.

11

Ref. No	Add-ress	New Parts	Parts No.	Description	Desti-nation	Re-marks
Δ D9			UDZ4.7B	ZENER DIODE		
Δ D10		*	D5SBA20F02	DIODE		
Δ D11			D2SBA20F03	DIODE		
D12			MA111	DIODE		
D13			UDZ11B	ZENER DIODE		
D14			UDZ13B	ZENER DIODE		
D15			UDZ6.8B	ZENER DIODE		
D16			MA111	DIODE		
D17			UDZ6.2B	ZENER DIODE		
Δ D18			S1ZB20(4101)	DIODE		
Δ D19 ,20			MA111	DIODE		
D21			UDZ6.2B	ZENER DIODE		
D22 -27			MA111	DIODE		
D28			DAN202U	DIODE		
D28			1SS301	DIODE		
D29			UDZ3.9B	ZENER DIODE		
D30			UDZ4.7B	ZENER DIODE		
D31 -39			MA111	DIODE	TE	
D40			MA111	DIODE		
D41			MA111	DIODE		
D42			UDZ10B	ZENER DIODE		
D43			MA111	DIODE		
D44			UDZ4.7B	ZENER DIODE		
D45			MA111	DIODE		
D400-404			MA111	DIODE		
Δ IC1		*	STK499-090	HYBRID IC		
IC2			LC75396NE	ANALOGUE IC		
IC3			BU4066BCF	ANALOGUE IC		
IC4		*	M30622MC-570FP	MI-COM IC		
IC5			HD6433297A17F	MI-COM IC		
Δ IC6		*	UPC2905HF	ANALOGUE IC	TE	
IC7			SAA6579T/R	ANALOGUE IC		
IC8			NJM4565M	ANALOGUE IC		
Δ IC9			S-806D-Z	ANALOGUE IC		
Δ IC10			SI-3050J	ANALOGUE IC		
IC11			NJM4565M	ANALOGUE IC		
IC400			LA9241M	DI BI-POLAR IC		
IC401		*	LC78628E	MOS-IC		
IC402			M56788FP	ANALOGUE IC		
IC403			NJM2100M	IC(OP AMPLIFIER)		
Q1 ,2			2SC4213(B)	TRANSISTOR		
Q3 -6			2SC1845(F,E)	TRANSISTOR		
Q7 -9			2SC4116(Y,GR)	TRANSISTOR		
Q7 -9			2SC4177(L5,L6)	TRANSISTOR		
Q10			2SA992(F,E)	TRANSISTOR		
Q11		*	2SA1576A(S)	TRANSISTOR		
Q12			2SC4213(B)	TRANSISTOR		
Q13 -15			UN5219	DIGITAL TRANSISTOR		
Q16 ,17			2SC4116(Y,GR)	TRANSISTOR		
Q16 ,17			2SC4177(L5,L6)	TRANSISTOR		
Q18			DTA124EUA	DIGITAL TRANSISTOR		
Q18			UN5112	DIGITAL TRANSISTOR		
Δ Q20			2SD2495*2	TRANSISTOR		
Q21			2SC1740S(Q,R)	TRANSISTOR		
Δ Q22			2SD2495*2	TRANSISTOR		

L : Scandinavia K : USA P : Canada R : Mexico C : China I : Malaysia

Y : PX(Far East, Hawaii) T : Europe E : Europe G : Germany V : China (Shanghai)

Y : AAFES(Europe) X : Australia Q : Russia H : Korea M : Other Areas Δ indicates safety critical components.

\* New Parts

Parts without **Parts No.** are not supplied.  
 Les articles non mentionnés dans le **Parts No.** ne sont pas fournis.  
 Teile ohne **Parts No.** werden nicht geliefert.

12

Ref. No	Add-ress	New Parts	Parts No.	Description	Desti-nation	Re-marks
Δ Q23			2SB1640	TRANSISTOR		
Q24			2SC1740S(Q,R)	TRANSISTOR		
Q25 ,26			2SC4116(Y,GR)	TRANSISTOR		
Q25 ,26			2SC4177(L5,L6)	TRANSISTOR		
Δ Q28			2SD2012	TRANSISTOR		
Δ Q29			2SC1740S(Q,R)	TRANSISTOR		
Q32		*	2SA1576A(S)	TRANSISTOR		
Δ Q33			2SB764(E,F)	TRANSISTOR		
Q40			2SC4116(Y,GR)	TRANSISTOR		
Q40			2SC4177(L5,L6)	TRANSISTOR		
Q50			2SC4116(Y,GR)	TRANSISTOR		
Q50			2SC4177(L5,L6)	TRANSISTOR		
Δ Q400			2SB1424(Q,R)	TRANSISTOR		
Q401			DTC124EUA	DIGITAL TRANSISTOR		
Q401			UN5212	DIGITAL TRANSISTOR		
Q403			2SK209(Y,GR)	FET		
Q404			2SB1424(Q,R)	TRANSISTOR		
Q410-413		*	2SA1576A(S)	TRANSISTOR		
Q414,415			DTC143TUA	DIGITAL TRANSISTOR		
Q414,415			UN5216	DIGITAL TRANSISTOR		
Q416			2SK209(Y,GR)	FET		
Q530			DTC124EUA	DIGITAL TRANSISTOR		
Q530			UN5212	DIGITAL TRANSISTOR		
A1			W02-1114-15	OSCILLATING MODULE		
<b>DISPLAY UNIT (X14-496X-XX)</b>						
D11			B30-2551-05	LED(BLUE,PHAI 3)		
D12			B30-2522-05	LED(RED,GREEN,3MM)		
C1			CC73FCH1H101J	CHIP C	100PF	J KMY
C2			CC45FCH1H221J	CERAMIC	220PF	J
C3 ,4			CC73FCH1H221J	CHIP C	220PF	J
C11			CK73FB1H103K	CHIP C	0.010UF	K
C13			C90-2595-05	ELECTRO	4.7UF	16WV
C14 ,15			CK73FB1H103K	CHIP C	0.010UF	K
C20 ,21			CC73FCH1H471J	CHIP C	470PF	J
C22 -24			CC73FCH1H220J	CHIP C	22PF	J
CN1			E40-4936-05	FLAT CABLE CONNECTOR		
CN2			E40-4288-05	SOCKET FOR PIN ASSY		
CN3			E40-3247-05	PIN ASSY		
J1			E70-0052-05	LOCK TERMINAL BOARD		
J2			E63-0164-05	PHONO JACK		
J3		*	E11-0392-05	PHONE JACK (7P)		
E5		*	F10-1149-04	SHIELDING PLATE		
E6		*	F10-1146-04	SHIELDING PLATE		
L1		*	L40-2701-31	SMALL FIXED INDUCTOR(27UH)		
L2 -4			L40-1001-31	SMALL FIXED INDUCTOR(10UH,K) TE		
R1 ,2			RK73FB2A101J	CHIP R	100	J 1/10W
R3			RK73FB2A182J	CHIP R	1.8K	J 1/10W
R4			RK73FB2A821J	CHIP R	820	J 1/10W
R5			RK73FB2A822J	CHIP R	8.2K	J 1/10W
R6			RK73FB2A473J	CHIP R	47K	J 1/10W
R7			RK73FB2A102J	CHIP R	1.0K	J 1/10W

L : Scandinavia K : USA P : Canada R : Mexico C : China I : Malaysia

Y : PX(Far East, Hawaii) T : Europe E : Europe G : Germany V : China (Shanghai)

Y : AAFES(Europe) X : Australia Q : Russia H : Korea M : Other Areas Δ indicates safety critical components.

\* New Parts

Parts without **Parts No.** are not supplied.  
Les articles non mentionnés dans le **Parts No.** ne sont pas fournis.  
Teile ohne **Parts No.** werden nicht geliefert.

13

Ref. No	Add-ress	New Parts	Parts No.	Description	Desti-nation	Re-marks
R13			RK73FB2A473J	CHIP R 47K J 1/10W		
R14			RK73EB2B101J	CHIP R 100 J 1/8W		
R15			RK73FB2A473J	CHIP R 47K J 1/10W		
R16			RK73EB2B101J	CHIP R 100 J 1/8W		
R17			RK73FB2A473J	CHIP R 47K J 1/10W		
R25			RK73FB2A332J	CHIP R 3.3K J 1/10W		
R26			RK73FB2A103J	CHIP R 10K J 1/10W		
R40 ,41			RK73FB2A101J	CHIP R 100 J 1/10W	TE	
R42			RK73FB2A101J	CHIP R 100 J 1/10W		
W1 ,2			R92-0679-05	CHIP R 0 OHM		
W3			R92-0670-05	CHIP R 0 OHM	TE	
W5 ,6			R92-0670-05	CHIP R 0 OHM		
W7 ,8			R92-0679-05	CHIP R 0 OHM		
W12			R92-0679-05	CHIP R 0 OHM		
W21 -24			R92-0670-05	CHIP R 0 OHM	KMY	
W25 ,26			R92-0679-05	CHIP R 0 OHM	KMY	
S2			S70-0072-05	TACT SWITCH		
S3 -13			S70-0031-05	TACT SWITCH		
S1		*	T99-0619-05	ROTARY ENCODER		
D1			UDZ3.3B	ZENER DIODE		
D13			MA111	DIODE		
Q1 ,2			2SC4213(B)	TRANSISTOR		
Q3			2SA1586(Y,GR)	TRANSISTOR		
Q3			2SA1611(M5,M6)	TRANSISTOR		
Q11			2SC1740S(Q,R)	TRANSISTOR		
Q11			2SC2785(F,E)	TRANSISTOR		
Q12 ,13			2SC4081(R,S)	TRANSISTOR		
Q12 ,13			2SC4116(Y,GR)	TRANSISTOR		
A1		*	W02-2673-15	TUNER ASSY	KMY	
A1		*	W02-2674-15	TUNER ASSY	TE	
A2			W02-2571-05	OPTIC RECEIVING MODULE		
<b>CD MECHANISM (D40-1638-05)</b>						
1	2A	*	J21-6716-08	MOUNTING HARDWARE ASSY(FRONT)		
2	2B	*	J21-6718-08	MOUNTING HARDWARE ASSY(REAR)		
3	1B	*	A11-1162-08	SUB CHASSIS ASSY(DISC GUIDE)		
4	1B	*	G01-4133-08	EXTENSION SPRING(ARM L)		
5	1A	*	G01-4135-08	EXTENSION SPRING(LOCK)		
6	1B	*	G01-4136-08	EXTENSION SPRING(TRIGGER A)		
7	1A	*	A11-1160-08	SUB CHASSIS ASSY(CLAMP)		
8	1A	*	G16-0971-08	SHEET(CLAMP)		
9	1A	*	A11-1166-08	SUB CHASSIS ASSY(ROLLER UNIT)		
10	2A	*	A11-1157-08	SUB CHASSIS ASSY(ROLLER)		
11	3A	*	A11-1158-08	SUB CHASSIS CAULKING ASSY(ROLL	E	
12	2A	*	D14-0670-04	ROLLER		
13	3A	*	D10-3878-08	ROD		
14	3A	*	D23-0333-08	RETAINER		
15	3B	*	D13-1939-08	GEAR(ROLLER)		
16	3A	*	B09-0266-08	CAP		
17	2A	*	J90-0869-08	GUIDE(DISC)		
18	2A	*	W10-0704-04	PRISM		
19	2A	*	J21-6720-08	MOUNTING HARDWARE(GUIDE)		
20	1A,2A	*	G01-4134-08	EXTENSION SPRING(ROLLER)		

L : Scandinavia K : USA P : Canada R : Mexico C : China I : Malaysia  
Y : PX(Far East, Hawaii) T : Europe E : Europe G : Germany V : China (Shanghai)  
Y : AAFES(Europe) X : Australia Q : Russia H : Korea M : Other Areas Δ indicates safety critical components.

\* New Parts

Parts without **Parts No.** are not supplied.  
Les articles non mentionnés dans le **Parts No.** ne sont pas fournis.  
Teile ohne **Parts No.** werden nicht geliefert.

14

Ref. No	Add-ress	New Parts	Parts No.	Description	Desti-nation	Re-marks
23	2B	*	D13-1933-08	GEAR(PULLEY)		
24	2B	*	D13-1934-08	GEAR(A)		
25	1A	*	T50-1082-08	YOKE		
26	2B	*	D13-1935-08	GEAR(B)		
27	3B	*	D13-1936-08	GEAR(C)		
28	3B	*	D10-3875-08	SLIDER ASSY(CHASSIS LOCK)		
30	1B	*	D10-3888-08	SLIDER(DISC GUIDE)		
31	2B	*	D10-3877-08	ARM(TRIGGER)		
32	3B	*	D10-3873-08	SLIDER ASSY(LOADING)		
33	1A	*	J11-0845-08	CLAMPER		
35	3B	*	D13-1937-08	GEAR(IDLER)		
36	2B	*	D13-1938-08	GEAR(FINAL)		
37	2B	*	A10-3474-08	CHASSIS ASSY(MAIN)		
38	3B	*	D16-0729-08	BELT		
39	2A	*	J02-1448-05	INSULATOR(RED)		
40	2B	*	J02-1447-05	INSULATOR(GREEN)		
41	3B	*	G01-4131-08	EXTENSION SPRING(SLIDER)		
42	3A	*	G01-4132-08	EXTENSION SPRING(CHASSIS LOCK)		
46	1B	*	G16-0972-08	SHEET(TU)		
49	2B	*	D40-1639-05	TRAVERSE UNIT(KSM-770AAA)		
50	3A	*	J26-0096-08	PCB ASSY		
51	3A	*	J80-0024-08	FPC		
52	3B	*	E35-2353-05	FFC(9P)		
53	1A	*	G16-0973-08	SHEET		
54	3B	*	T42-0946-08	MOTOR ASSY		
AA		*	N09-5129-08	SCREW		
AB		*	N89-2606-46	SCREW		
AC		*	N09-5113-08	SCREW		
AD		*	N19-1105-04	WASHER	1.6X4X0.5	
AE		*	N09-3366-08	SCREW		

L : Scandinavia K : USA P : Canada R : Mexico C : China I : Malaysia  
Y : PX(Far East, Hawaii) T : Europe E : Europe G : Germany V : China (Shanghai)  
Y : AAFES(Europe) X : Australia Q : Russia H : Korea M : Other Areas Δ indicates safety critical components.

PARTS LIST

RD-VH7

## SPECIFICATIONS

### (For U.S.A. and U.S. military)

#### [Amplifier section]

Rated power output

Continuous rated power output (FTC)

15 watts per channel minimum RMS, both channels driven, at 6 Ω 60 Hz to 20,000 Hz with no more than 0.9 % total harmonic distortion.

Total harmonic distortion ..... 0.05 % (1 kHz, 10 W, 6 Ω)  
 Frequency response  
 Line (AUX, TAPE, MD) ..... 20 Hz ~ 50 kHz, +0 dB, -3 dB  
 Signal to noise ratio  
 Line (AUX, TAPE, MD) ..... 93 dB (IHF'66)  
 Tone control  
 BASS ..... ± 8 dB (at 120 Hz)  
 TREBLE ..... ± 8 dB (at 10 kHz)  
 Input sensitivity / Impedance  
 Line (AUX, TAPE, MD) ..... 210 mV / 47 kΩ  
 Output level / Impedance  
 TAPE REC (MD REC) ..... 210 mV / 100 Ω

#### [FM Tuner section]

Tuning frequency range ..... 87.5 MHz ~ 108 MHz  
 Usable sensitivity (MONO at 75 Ω)  
 ..... 2.0 μV / 17.2 dBf (75 kHz dev., SINAD, 30 dB)  
 50 dB quieting sensitivity (at 75 Ω)  
 STEREO ..... 35 μV / 42.2 dBf  
 Total harmonic distortion (at 1 kHz)  
 MONO ..... 0.6 % (65 dBf input)  
 STEREO ..... 0.7 % (65 dBf input)  
 Signal to noise ratio (at 1 kHz, 75 kHz Dev.)  
 MONO ..... 70 dB (75 kHz dev. 65 dBf input)  
 STEREO ..... 65 dB (75 kHz dev. 65 dBf input)  
 Stereo separation (1 kHz) ..... 38 dB  
 Frequency response (100 Hz ~ 15 kHz)  
 ..... +0.5 dB, -3.0 dB

#### [AM Tuner section]

Tuning frequency range ..... 530 kHz ~ 1700 kHz  
 Usable sensitivity (30 % mod., S/N 20 dB)  
 ..... 18 μV / (500 μV/m)  
 Signal to noise ratio (at 30 % mod., 1 mV input)  
 ..... 45 dB

#### [CD player section]

Laser ..... Semiconductor laser  
 Playing rotation ..... 200 rpm ~ 500 rpm (CLV)  
 Frequency response ..... 4 Hz ~ 20 kHz  
 Signal to noise ratio ..... More than 96 dB  
 Total harmonic distortion ..... Less than 0.01 % (at 1 kHz)  
 Channel separation ..... More than 92 dB (at 1 kHz)  
 Wow & Flutter ..... Unmeasurable Limit  
 Output level / Impedance  
 Fixed ..... 1.2 V / 1 kΩ

### (For U.K. and Europe)

#### [Amplifier section]

Rated power output

Effective output power (1 kHz, 6 Ω)(DIN)

..... 16 W + 16 W  
 Output power (1 kHz, 6 Ω, 10 %) (MRS)  
 ..... 20 W + 20 W  
 Total harmonic distortion ..... 0.05 % (1 kHz, 10 W, 6 Ω)  
 Frequency response  
 Line (AUX, TAPE, MD) ..... 20 Hz ~ 50 kHz, +0 dB, -3 dB  
 Signal to noise ratio  
 Line (AUX, TAPE, MD) ..... 93 dB (IHF'66)  
 Tone control  
 BASS ..... ± 8 dB (at 120 Hz)  
 TREBLE ..... ± 8 dB (at 10 kHz)  
 Input sensitivity / Impedance  
 Line (AUX, TAPE, MD) ..... 210 mV / 47 kΩ  
 Output level / Impedance  
 TAPE REC (MD REC) ..... 210 mV / 100 Ω

#### [FM Tuner section]

Tuning frequency range ..... 87.5 MHz ~ 108 MHz  
 Usable sensitivity (DIN at 75 Ω)  
 MONO ..... 1.6 μV / 14.2 dBf (40 kHz dev., S/N 26 dB)  
 STEREO ..... 45 μV / 44.2 dBf (46 kHz dev., S/N 46 dB)  
 Total harmonic distortion (DIN at 1 kHz)  
 MONO ..... 0.3 % (65.2 dBf input)  
 STEREO ..... 0.9 % (65.2 dBf input)  
 Signal to noise ratio (at 1 kHz, 75 kHz Dev.)  
 MONO ..... 65 dB (40 kHz dev., 65.2 dBf input)  
 STEREO ..... 59 dB (40 kHz dev., 65.2 dBf input)  
 Stereo separation (DIN) (1 kHz) ..... 36 dB  
 Selectivity (DIN ± 300 kHz) ..... 64 dB  
 Frequency response (100 Hz ~ 15 kHz)  
 ..... +0.5 dB, -3.0 dB  
 Stereo separation (1 kHz) ..... 38 dB

#### [AM Tuner section]

Tuning frequency range ..... 531 kHz ~ 1602 kHz  
 Usable sensitivity (30 % mod., S/N 20 dB)  
 ..... 18 μV / (700 μV/m)  
 Signal to noise ratio (at 30 % mod., 1 mV input)  
 ..... 45 dB  
 Total harmonic distortion ..... 1.0 %

Digital output

Optical ..... -15 dBm ~ -21 dBm  
 (wave length 660 nm)

#### [General]

Power consumption ..... 60 W  
 Dimensions  
 (Horizontal installation) ..... W: 247 mm (9-3/4 in.)  
 H: 96 mm (3-7/8 in.)  
 D: 291 mm (11-1/2 in.)  
 Weight (net) ..... 4.0 kg (8.1 lb)



1. KENWOOD follows a policy of continuous advancements in development. For this reason specifications may be changed without notice.
2. Sufficient performance may not be possible at very low temperatures (0°C or less).

#### Note:

Component and circuit are subject to modification to insure best operation under differing local conditions. This manual is based on Europe (E) standard, and provides information on regional circuit modification through use of alternate schematic diagrams, and information on regional component variations through use of parts list.

## KENWOOD CORPORATION

14-6, Dogenzaka 1-chome, Shibuya-ku, Tokyo, 150-8501 Japan

### KENWOOD SERVICE CORPORATION

P.O. BOX 22745, 2201 East Dominguez St., Long Beach, CA 90801-5745, U.S.A.