

STEREO INTEGRATED AMPLIFIER/TUNER
R-SG7/SG7G
 SERVICE MANUAL

KENWOOD

© 1999-7/B51-5549-00 (K/K) 2299

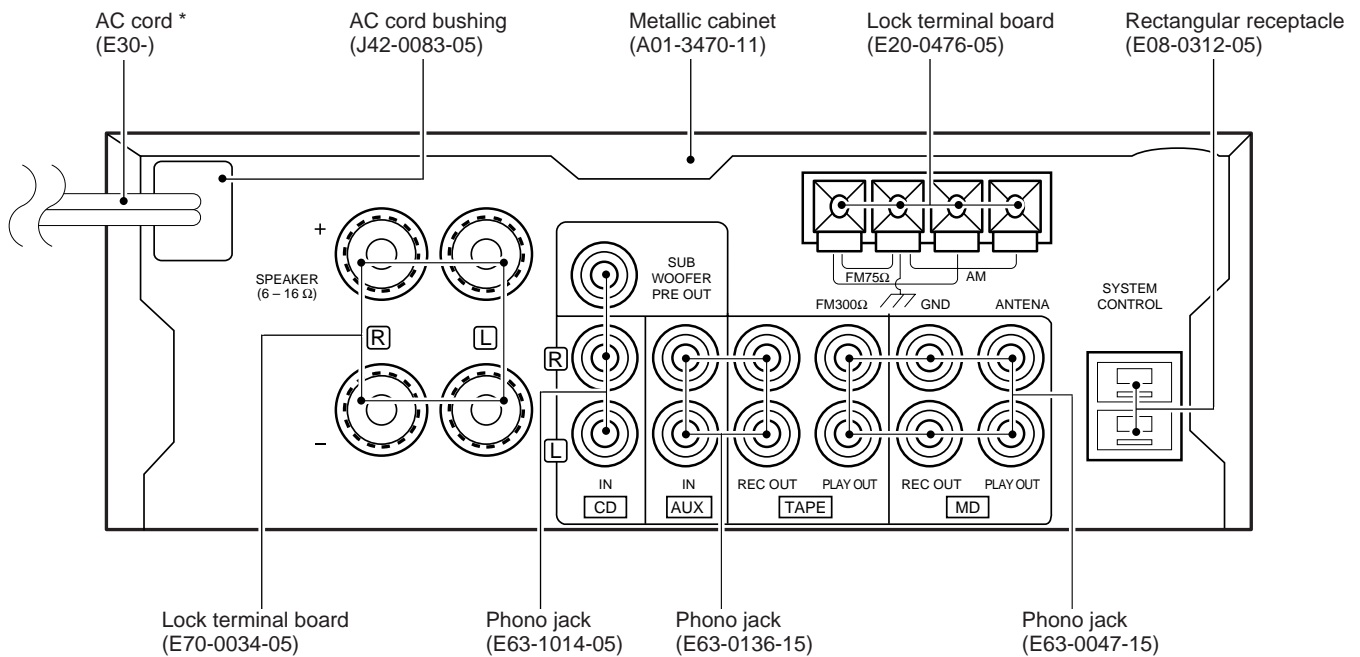
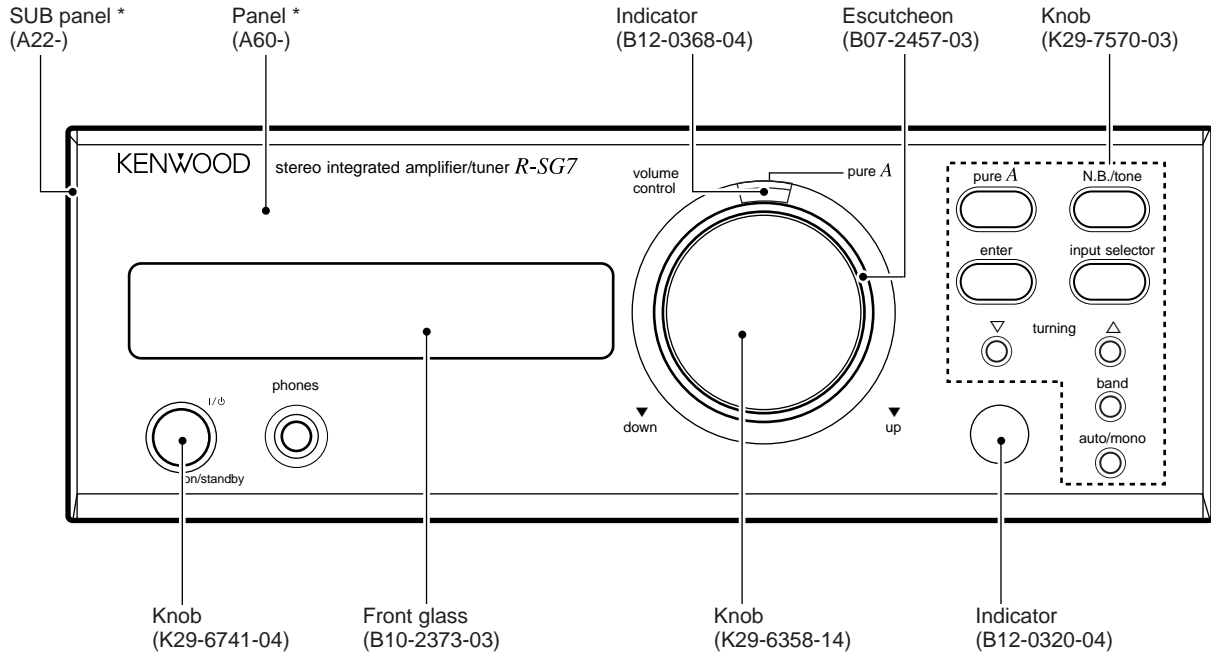

* Refer to parts list on page 23.



R-SG7/SG7G

CONTENTS / ACCESSORIES

Contents

CONTENTS / ACCESSORIES	2	SCHEMATIC DIAGRAM	11
CIRCUIT DESCRIPTION	3	EXPLODED VIEW	22
ADJUSTMENT	7	PARTS LIST	23
PC BOARD	8	SPECIFICATIONS	Back cover

Accessories

AM loop antenna (1)
(T90-0833-05)

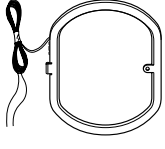

AM loop antenna stand (1)
(J19-3645-05)

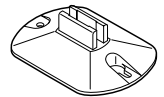

FM indoor antenna (1)
(T90-0801-15) : M
(T90-0809-05) : ET



Batteries (R6/AA) (2)

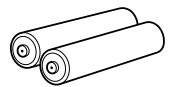

Audio cords (2)
(E30-0615-05)

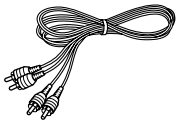

System control cord (1)
(E30-2628-05)

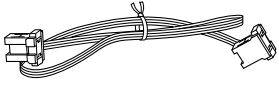

AC plug adaptor (1)
(E03-0115-05)

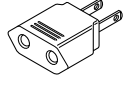

Remote control unit (1)
(A70-1154-05) : M RC-SE9
(A70-1155-05) : TE RC-SE9(E)

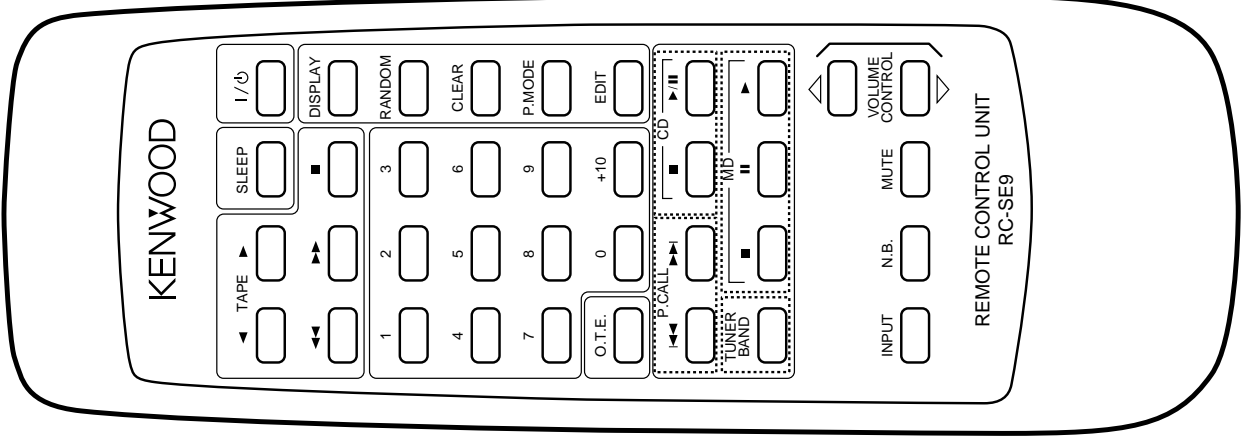

Battery cover (A09-0356-08)

Operation to reset

The microcomputer may fall into malfunction (impossibility to operate, erroneous display, etc.) when the power cord is unplugged while power is ON or due to an external factor. In this case, execute the following procedure to reset the microcomputer and return it to normal condition.

- Please note that resetting the microcomputer clears the contents stored in it returns it to condition when it left the factory.

R-SG7

Pull the power plug from the receptacle, and then plug it in again while keeping the "on/standby" key pressed.

CIRCUIT DESCRIPTION

1. INITIAL STATE

(1) AMP related block

- POWEROFF
- SELECTOR SOURCETUNER
- DISPLAY.....SELECTOR
- N.B.CIRCUITOFF
- A CLASS VOLUME VALUE
.....1.80 STEP
- AB CLASS VOLUME VALUE
.....9 STEP
- PURE A MODE.....NORMAL(AB CLASS)
- AUTO POWER SAVE.....OFF

(2) TUNER related block

- BAND.....FM
- P.CH MEMORYLAST FREQUENCY
- LAST P.CH01ch
- RDS DATA TABLE MEMORY
.....NO DATA
- RECEIVING FREQUENCY
.....LOWER LIMIT
VALUE OF
RECEIVING FREQUENCY
FM : 87.5MHz
AM : 531kHz
- AUTO/MANUAL.....AUTO
- EON THRUST RECEIVING MODE
.....OFF

(3) TIMER related block

- CLOCKSTOP(AM12:00)
- PROGR.....WORKIG MODE (OFF)
CONTENTS OF PROGRAM
.....ON=AM12:00
OFF=AM12:00
PLAY MODE=PLAY
SELECTOR=TUNER(1ch)
REC MODE=TAPE
- O.T.T.....WORKING MODE (OFF)
O.T.T.ON TIME.....AM7:00

2. INITIALIZING

2-1 The method of the initializing

The system is initialized when the power is turned on while pressing the [ON/STANDBY] key.

(1) Contents of the operation

- All the functions are initialized.

3. BACK UP

This function holds the current state of the unit even if the AC power of the receiver is turned OFF.

(1) Operation outline

The backup state set command(CE) of a microcomputer is set low when the AC power is turned OFF. The microcomputer detects the signal and enters the stop state.

The microcomputer is reset when the AC power is turned ON. The data for backup state confirmation is checked by reset processing. The microcomputer is initialized when the data was destroyed. If it is not destroyed, the microcomputer is started in the backup state.

- The data for backup state confirmation is written in a RAM area.
 - The microcomputer is set to the stop mode so as to save the power consumption.
 - A backup state set command signal is detected by a timer interrupt of 1 msec.
 - The backup guarantee period is set in a circuit.
- (2) Contents of backup data to be held

... .. AMP

- POWER ON/OFF
- DISPLAY MODE
- SELECTOR SOURCE
- N.B.CIRCUIT MODE
- A CLASS VOLUME VALUE
- AB CLASS VOLUME VALUE
- PURE A MODE
- AUTO POWER SAVE ON/OFF

... .. TUNER

- LAST BAND
- PRESET CHANNEL/RECEIVING FREQUENCY/PI/TA/PTY/PS
- LAST RECEIVING FREQUENCY AND PRESET CHANNEL (AM/FM)
- PRESET MEMORY DATA(1ch~40ch)
- AUTO/MANUAL
- EON THRUST RECEIVING FREQUENCY

... .. CLOCK/TIMER

- LAST CLOCK DATA
- PROGRAMMED CONTENTS/PROGRAM TIMER WORKING MODE ON/OFF
- O.T.T. SETTING TIME/WORKING MODE ON/OFF

4. CONDITIONS ACCORDING TO THE DESTINATION

4-1 Destination list of tuner

Desti- nation	Band	Receiving frequency range	Channel space	IF	PLL reference frequency	DIODE SW	
						DSW1 (D519)	DSW2 (D518)
E1	FM	87.5MHz~ 108.0MHz	50kHz	+10.7MHz	25kHz	0	1
	AM	531kHz~ 1602kHz	9kHz	+450kHz	9kHz		
E3 (RDS)	FM	87.5MHz~ 108.0MHz	50kHz	+10.7MHz	25kHz	1	0
	AM	531kHz~ 1602kHz	9kHz	+450kHz	9kHz		
M	E1 changes by only setting " DSW1". (DSW1 0,E1)					X	1

*DIODE SW(DSW) : 0 Without diode(when static, input low)
1 With diode(when static, input high)
X Switching transistor

R-SG7/SG7G

CIRCUIT DESCRIPTION

5. TEST MODE

5-1 AMP test mode using main unit's keys

- Entering the AMP test mode
Turn on the power while pressing the[BAND] key.
- Canceling the AMP test mode
By turning off the power, the system is initialized and the test mode is canceled.

5-1-1 Contents of AMP test mode

(1) Automatic on/standby ON

- The POWER ON state is entered when the power is turned on while pressing the [BAND]key. All functions are then initialized and activated in the all-lighting mode.
- Sub-clock oscillation diagnosis function
The oscillation diagnosis (existence of oscillation and measurement of period) of a sub-clock is performed before the test mode is entered. If the diagnosis result is OK,the system enters the test mode. If the diagnosis result is NG,the oscillation of the sub-clock is diagnosed again. If the result is OK, the system enters the test mode. If the diagnosis result is continuously NG five times, the system stops with ERR1 and ERR2 displayed.

(2) All- lighting mode

- All the fluorescent display indicators and LED lamps light when the power is turned on while pressing the [BAND] key. After that, all- lighting mode is canceled when any main unit's key is pressed. The normal display is obtained when the selector is set to TUNER then appears.

(3) Others

- The AMP test mode is not terminated even if the selector is set to positions other than TUNER.
- In the AMP test mode,the muting during mode selection is not controlled. However, the operation during the power-on sequence is the same as the normal operation.
- The SP protection operation is also the same as the normal operation.
- In the AMP test mode using main unit's keys,the keys below provide a special operation according to the position where the selector is set. The main unit key's except described below and the rotary encoder provide the normal operation.

(4) When selector is set toTUNER

Keys	Operation
PURE A	Increase the P.CALL every time this key is pressed.
N.B./TONE	Decrease the P.CALL every time this key is pressed.
ENTER	Selects the display cyclically in the order below every time this key is pressed.

- ① Write data in the unused area of E2PROM, then read the written data. If the read data is the same as the written data, RAM OK is displayed in the fluorescent display indicator. If the former is the different from the later, RAM NG is displayed.
- ② Set the TUNER ATT to OFF and display the S level in hexadecimal when the [ENTER] key is pressed . (ATT OFF * * is displayed in the fluorescent display indicator.)

- ③ Set the TUNER ATT to ON and the display S level in hexadecimal when the [ENTER] key is pressed. (ATT ON * * is displayed in the fluorescent display indicator.)

* The special display using the [ENTER] key is continued until the next operation is carried out. (* * : S LEVEL)
When keys other then ENTER are pressed in items ① to ③ above, the TUNER ATT is set to OFF and the normal display appears. The operation corresponding to the key that has been pressed performed in this case.

- (5) When selector is set to positions other than TUNER.

① ENTER and PURE A keys.

The master volume level is selected cyclically, while pressing the [ENTER] key.

Value of Master volume.	Press the ENTER key.	Press the PURE A key, then press the ENTER key.
MAX	86	16.00
MID	40	8.00
MIN	1	0.20

② AUTO/MONO key.

Selects the mute operation and equalizer cyclically in the order below for operation display every time this key is pressed.

KEY	OPERATION
AUTO/MONO	

*In the operation for except the AUTO key, become pre-condition equalizer.

*Pre -condition : The equalizer becomes the condition to be pushed the AUTO key before (include N.B. circuit).

③ BAND and tuning UP/DOWN keys.

KEYS	OPERATION
BAND	Every time this key is pressed, all the displays go off and the normal display is selected cyclically.
TUNING UP/DOWN	

CIRCUIT DESCRIPTION

6. Microprocessor : uPD78045FGF071(X09-IC11)

6-1 Microprocessor periphery block diagram

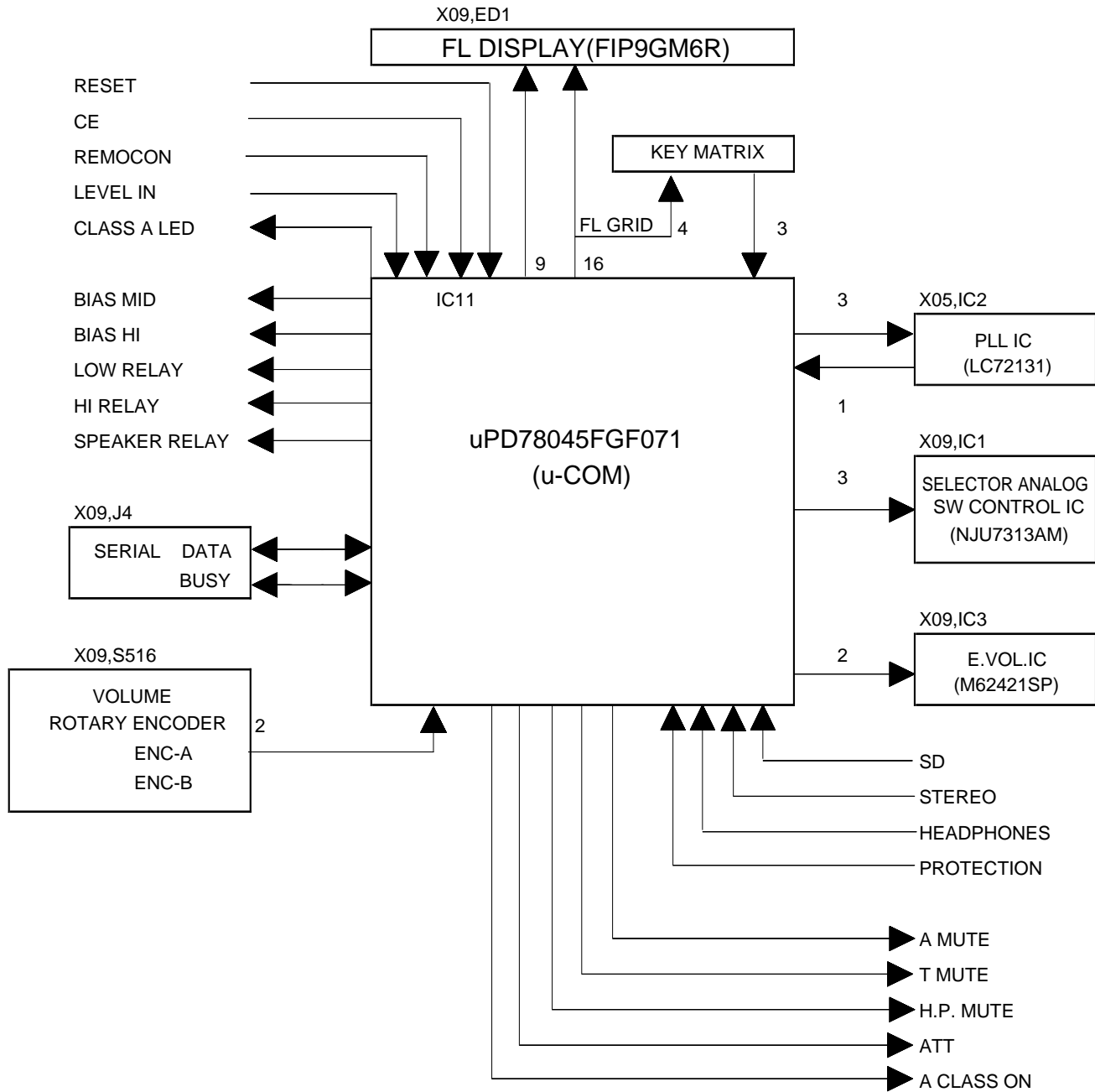

Key matrix

○ signifies pin number of microprocessor.

	KR0 (60)	KR1 (59)	KR2 (58)
KS0 (64)		DSW1(D519)	DSW2(D518)
KS1 (63)	POWER	AUTO/MONO	BAND
KS2 (62)	N.B. CIRCUIT	INPUT SEL.	TUNING UP
KS3 (61)	pure A	ENTER	TUNING DOWN

R-SG7/SG7G

CIRCUIT DESCRIPTION

6-2 Pin description

Pin No.	Pin Name	I/O	Description	Active
1~7	7G~1G	O	FL grid7~1.	
8	VDD	-	Microprocessor power supply (+5V).	
9	E2PROM SCL	I	E2PROM control clock.	
10	E2PROM SDA	I/O	E2PROM control data.	
11,12	NC	-	Unused.	
13	A CLASS ON	O	POWER ON/OFF control signal.	H : ON L : OFF
14	SEL STB	O	Strobe signal of selector IC.	
15	SEL/PLL/CLK	O	Control clock of SEL/PLL IC.	
16	SEL/PLL/DATA	O	Control data of SEL/PLL IC.	
17	RESET	I	Reset signal of microprocessor.	L : Reset
18	CE	I	Detection signal input for AC OFF.	
19	PLL DO	I	PLL IF count data.	
20	AVss	-	A/D power supply(GND).	
21	PLL CE	O	Chip enable control of PLL IC.	L : ON
22	T MUTE	O	Output terminal of muting signal for TUNER.	L : ON
23	STEREO	I	Stereo signal input for TUNER.	L : Stereo ON
24	SD	I	Synchronized signal detection input.	
25	VOL SCL	O	Control clock of E. volume IC.	
26	VOL DATA	O	Control data of E. volume IC.	L : CE
27	LEVEL IN	I	Volume level input.	H : ON L : OFF
28	S LEVEL	I	Signal level input.(E/T type only)	
29	A Vdd	-	A/D power supply(+5V).	
30	A VREF	-	A/D reference voltage(+5V).	
31	CLOCK	-	32.768kHz oscillator.	
32	CLOCK	-	32.768kHz oscillator.	
33	Vss	-	Microprocessor power supply(GND).	
34	MAIN COLCK	-	4.19MHz oscillator.	
35	MAIN COLCK	-	4.19MHz oscillator.	
36	S DATA	I/O	16 bit system data.	
37	S BUSY	I/O	16 bit system busy.	H : BUSY L : READY
38	H.P. MUTE	O	Muting signal input of headphones.	L : ON
39	ATT	O	Attenuator control.	L : ON
40	A MUTE	O	Audio muting signal control.	L : ON
41	LOW RELAY	O	Amplifier low relay control.	H : ON L : OFF
42	HI RELAY	O	Amplifier high relay control.	H : ON L : OFF
43	SP RELAY	O	Speaker relay control.	
44,45	NC	I	Unused.	
46	PROTECTION	I	Detection signal input of protection.	H : ON L : OFF
47	REMOCON	I	Remote control input.	
48	IC(VPP)GND	-	Connected to VSS.	
49	CLASS A LED	O	Control signal output of class A LED.	L : ON
50	BIAS A MID	O	Bias control signal(MID) output.	
51	BIAS B HI	O	Bias control signal(HI) of class A LED.	
52	Vdd	-	Microprocessor power supply(+5V).	
53	ENC A	I	Volume encoder (A) input.	
54	ENC B	I	Volume encoder (B) input.	
55	HEAD PHONES	I	Detection signal input of headphones.	H : ON L : OFF
56,57	-	O	Unused.	
58~60	KR2~KR0	I	Key return input(KR2~KR0).	H : Key ON
61~64	P16~13/KS3~0	O	FL segment(6~13)/key scan(KS3~KS0).	H : ON
65~70	P12~P7	O	FL segment(12~7) control.	H : ON
71	VLOAD	-	FL driver power supply(-30V).	
72~77	P6~P1	O	FL segment(6~1) control.	H : ON
78	NC	-	Unused.	
79,80	9G,8G	O	FL grid(9G,8G) control.	

ADJUSTMENT

FM SECTION SELECTION : FM X05-4882-70 (E/T TYPE)

NO.	ITEM	INPUT SETTINGS	OUTPUT SETTINGS	TUNER SETTINGS	ALIGNMENT POINTS	ALIGN FOR	FIG.
1	DISCRIMINATOR	(A) 98.0kHz 1kHz, ± 75 kHz dev. 60dB μ (ANT input)	Connect a DC voltmeter between Pin 1 and Pin 2 of CN 2.	MONO 98.0MHz	L 31	0V	(a)
					L 32	Minimum distortion.	
2	DISTORTION (STEREO)	(C) 98.0MHz 1kHz, ± 68.25 kHz dev. Pilot: ± 6.75 kHz dev. 60dB μ (ANT input)	(B)	AUTO 98.0MHz	IFT (A1)	Minimum distortion.	(a)

X05-488X(E/T)/486X(M)

No.	ITEM	INPUT SETTING	OUTPUT SETTING	TUNER SETTING	ALIGNMENT POINTS	ALIGN FOR	FIG.
1	TUNED LEVEL	(A) 98.0MHz MONO 1 kHz, ± 75 kHz dev. 30dBu ± 10 dB (ANT input)	(B)	MONO 98.0MHz	VR1	Adjust VR1 and stop at the point where EDI (TUNED) goes ON.	(a)

SYSTEM CONNECTIONS

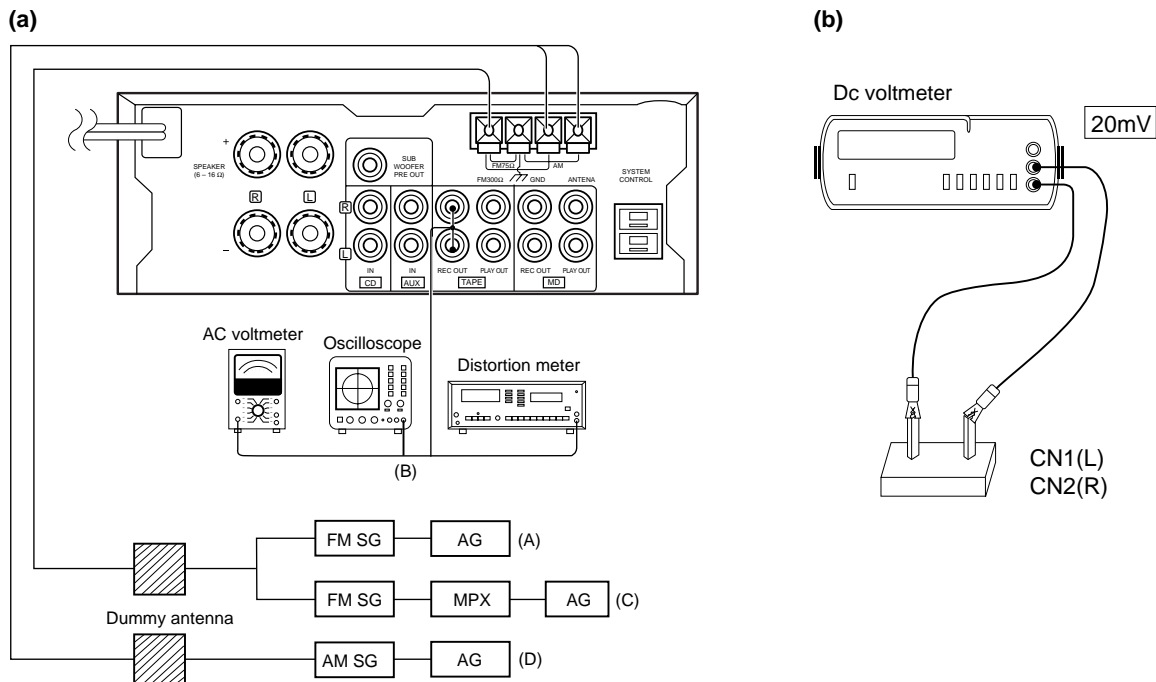

AUDIO SECTION (X09-496x-xx)

NO.	ITEM	INPUT SETTINGS	OUTPUT SETTINGS	AMP SETTINGS	ALIGNMENT POINTS	ALIGN FOR	FIG.
POWER: ON SELECTOR : AUX							
1	B CLASS IDLE CURRENT	-	Connect a DC voltmeter across CN1(L) CN2(R) (X09, A/7)	PURE A : OFF Volume : 0	VR1(L) VR2(R) (X09, A/7)	20mV	(b)

PC BOARD (Component side view)

TUNER UNIT (X05-4860-71) : M

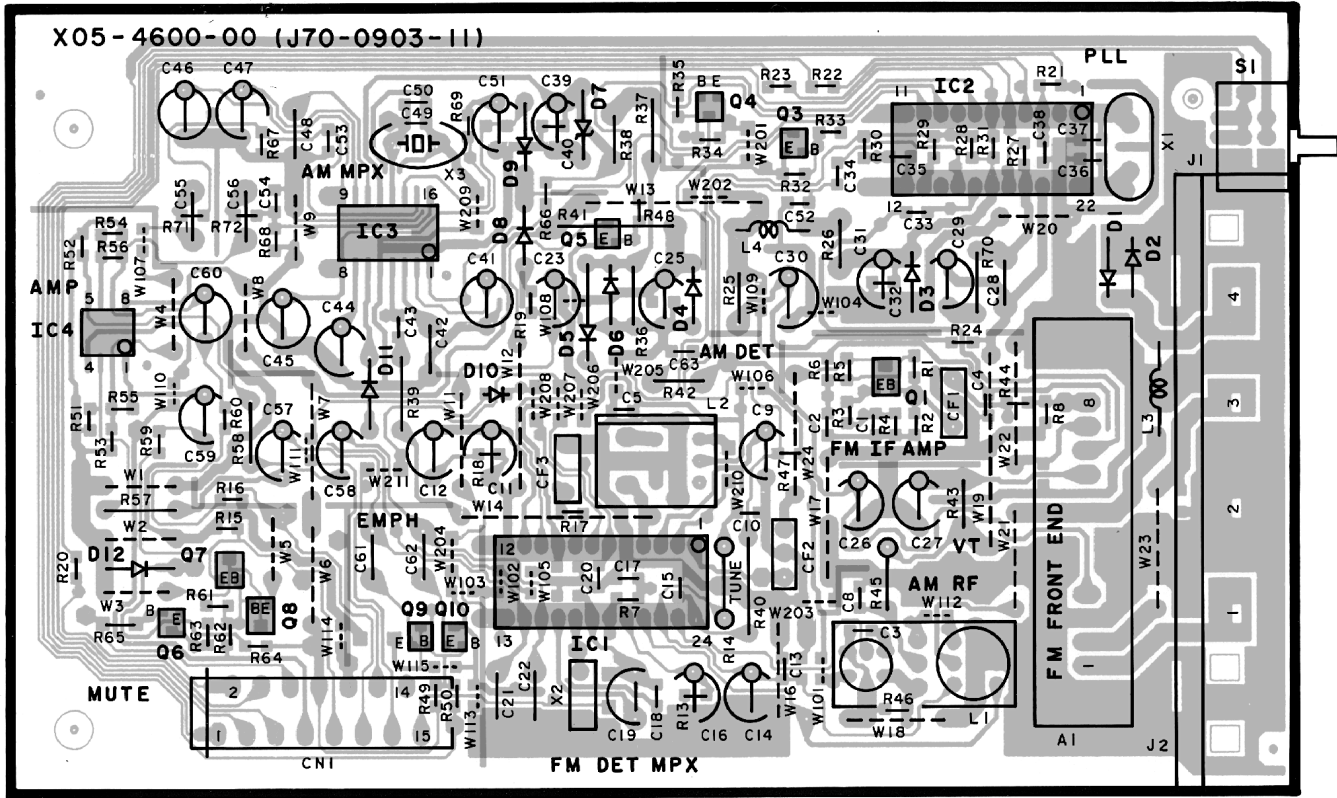

TUNER UNIT (X05-4882-70) : ET

DC voltmeter
Discriminator : 0V

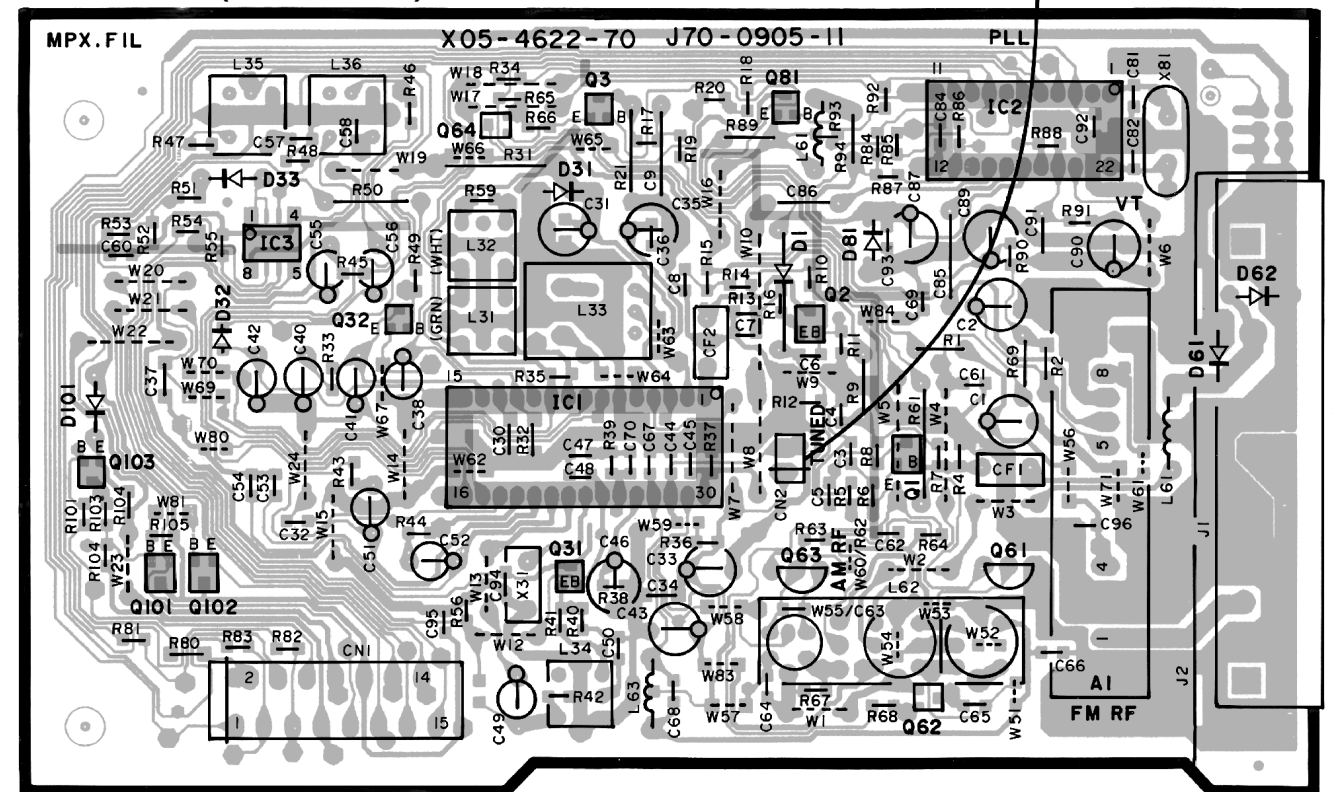

Refer to the schematic diagram for the value of resistors and capacitors.

PC BOARD(Component side view)

X09 E/7

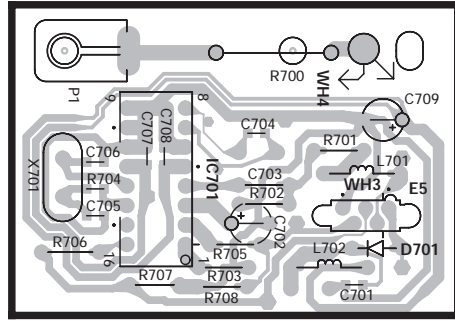

X09 D/7

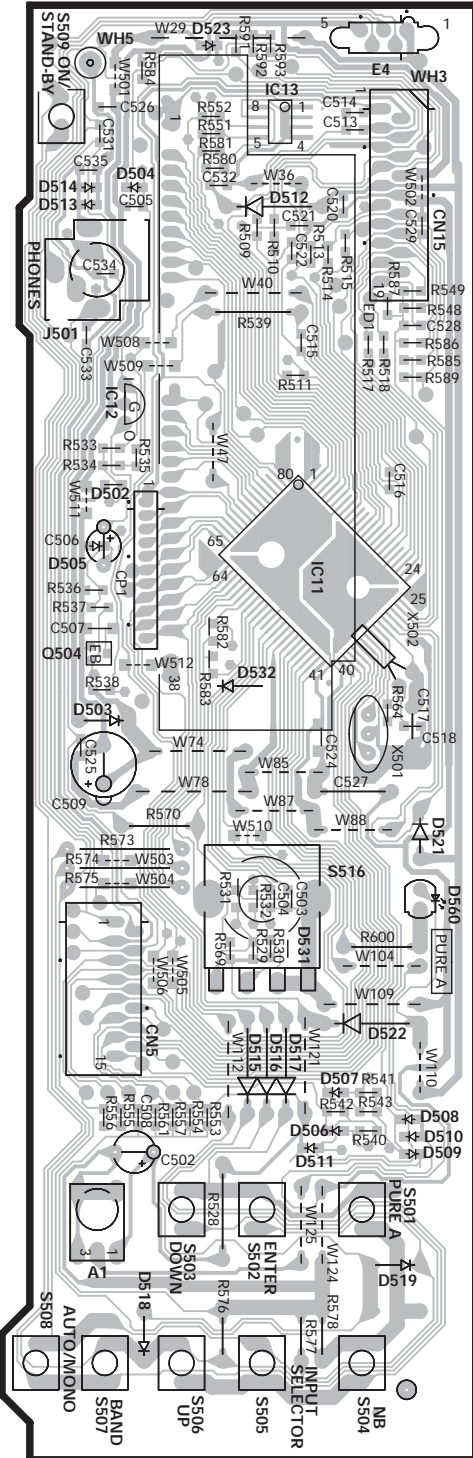

X09-4690-22 A/7 : M 2-72 : ET

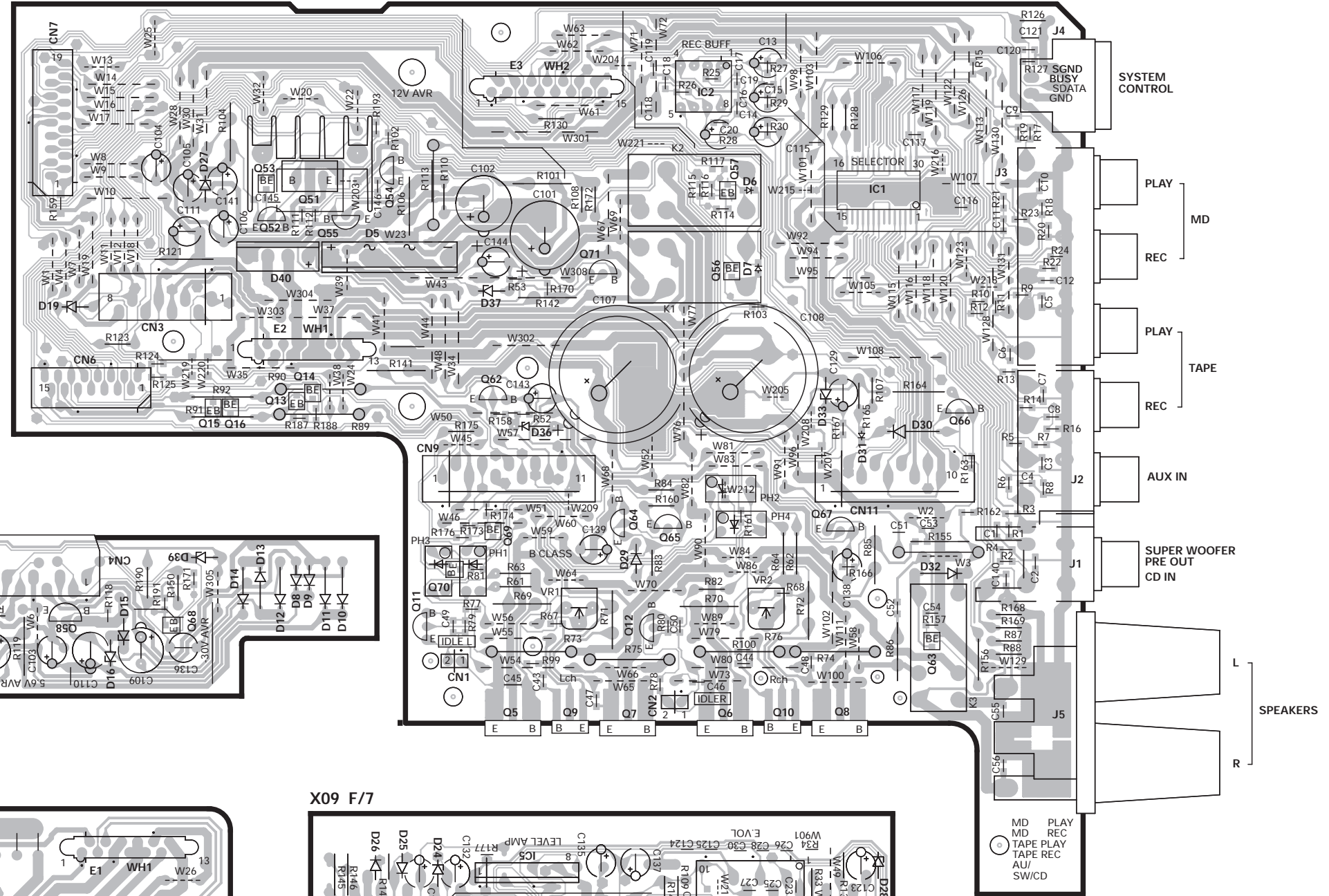

X09 C/7

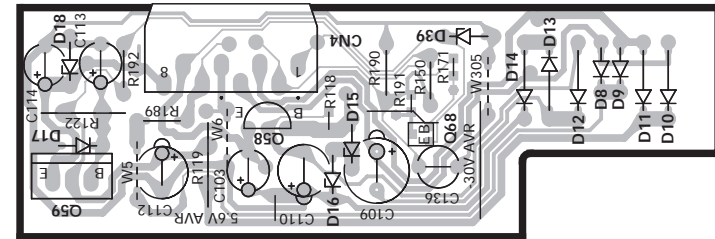

X09 B/7

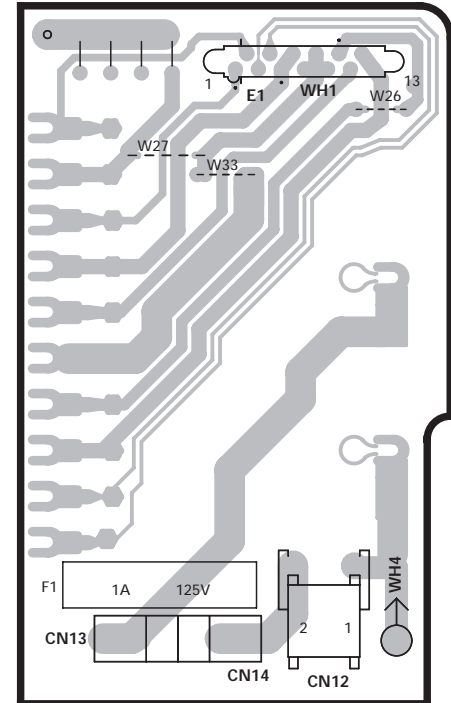

X09 F/7

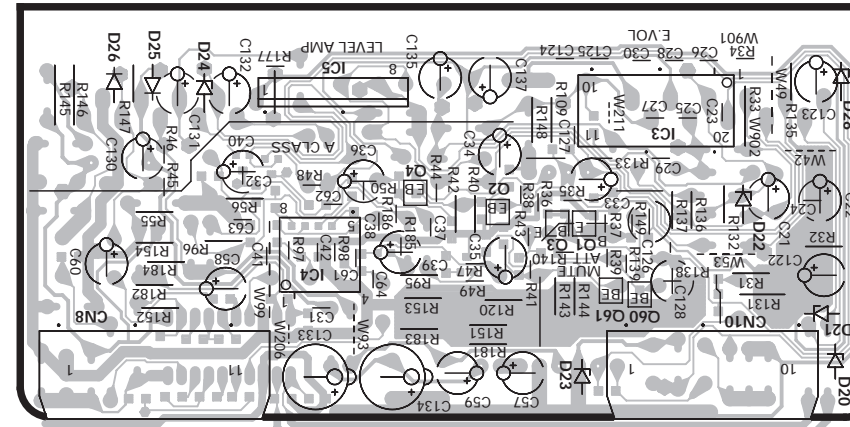

Refer to the schematic diagram for the value of resistors and capacitors.

TUNER UNIT (X05-4860-71) : M TYPE

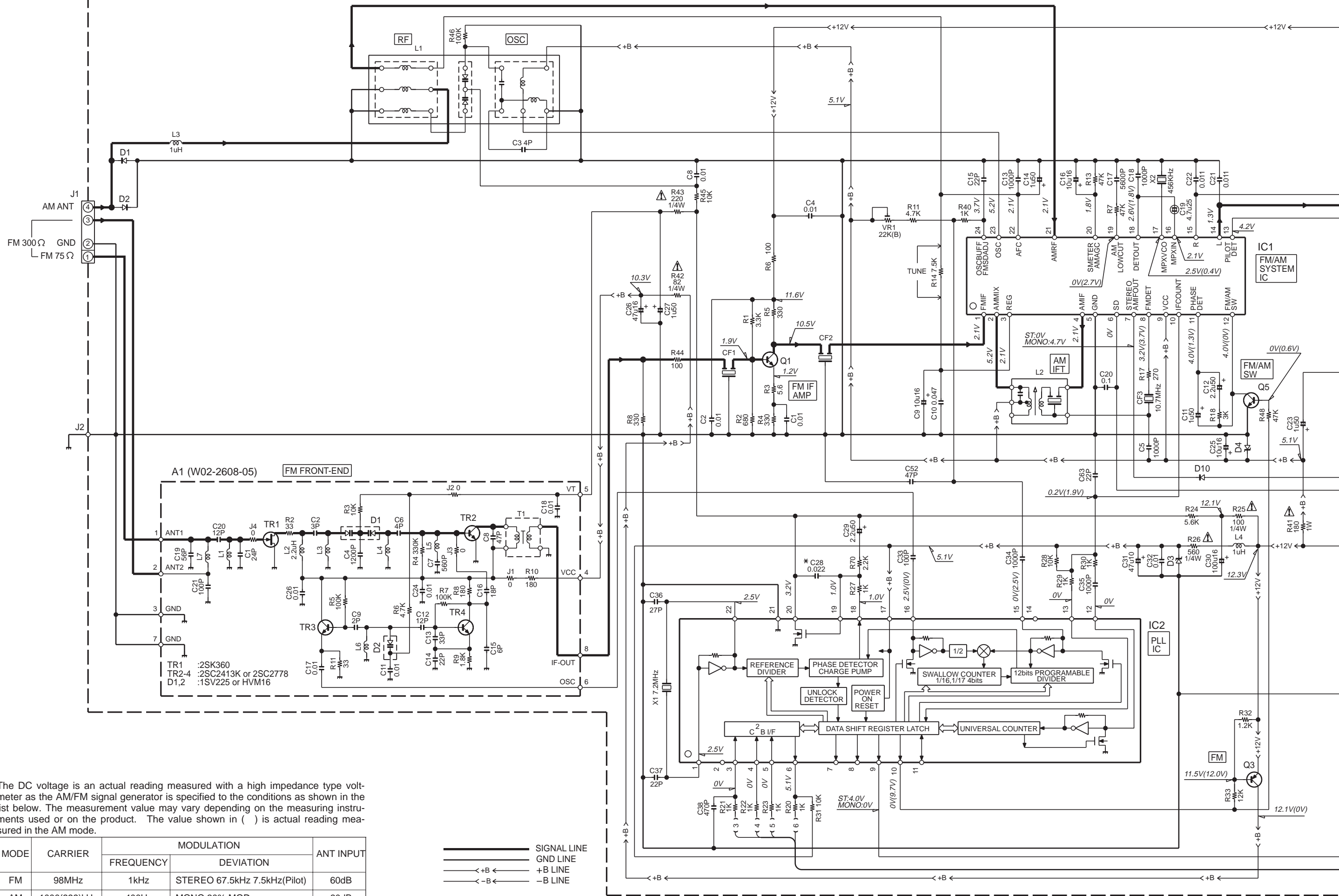

The DC voltage is an actual reading measured with a high impedance type voltmeter as the AM/FM signal generator is specified to the conditions as shown in the list below. The measurement value may vary depending on the measuring instruments used or on the product. The value shown in () is actual reading measured in the AM mode.

MODE	CARRIER	MODULATION		ANT INPUT
		FREQUENCY	DEVIATION	
FM	98MHz	1kHz	STEREO 67.5kHz 7.5kHz(Pilot)	60dB
AM	1000(999)kHz	400Hz	MONO 30% MOD	60dB

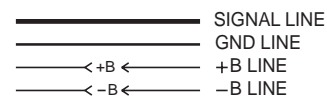

(X05-4860-71): M TYPE

- IC1 : LA1832
- IC2 : LC72131
- IC4 : NJM4565M
- Q1 : 2SC2714(R,O)
- Q3 : 2SB1218A(Q,R) or 2SA1576A(R,S)
- Q5 : 2SD1819A(Q,R) or 2SC4081(R,S)
- D1,2,8 : 1SS133 or HSS104
- D3,4 : MTZJ5.1(B) or HZS5.1NN(B2)
- D10 : MA111

- 2SA1534A
- 2SA954
- 2SA992
- 2SB764
- 2SC1845
- 2SC2003

- UN5219
- 2SA1576A
- 2SB1218A
- 2SC2714
- 2SD1819A

2SC4137

2SC4081

NJM4565D-D

M5219P

NJM4565M

M5223FP

LA1836

VT VOLTAGE
LF: LOW FREQUENCY
HF: HIGH FREQUENCY

BAND	FREQ.	VT VOLTAGE
FM	LF	1.7V
	HF	4.1V
AM	LF	1.2V
	HF	4.7V

LC72131

NJU7133AM

NJM4565L-D

LA1832

X24C04S

SAA6579

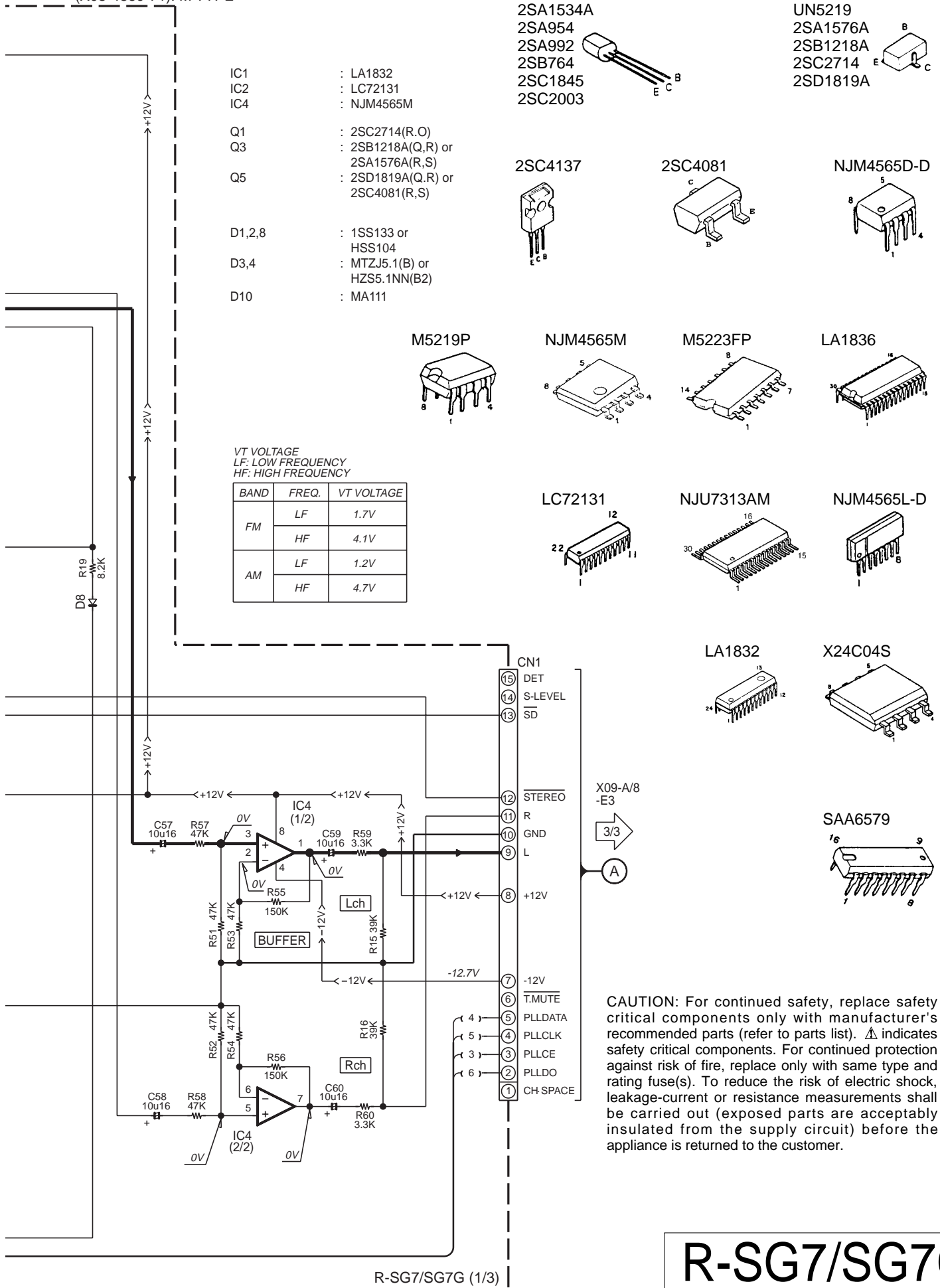

R-SG7/SG7G (1/3)

Y05-3960-21

R-SG7/SG7G

KENWOOD

TUNER UNIT (X05-4882-70) : (E,T)TYPE

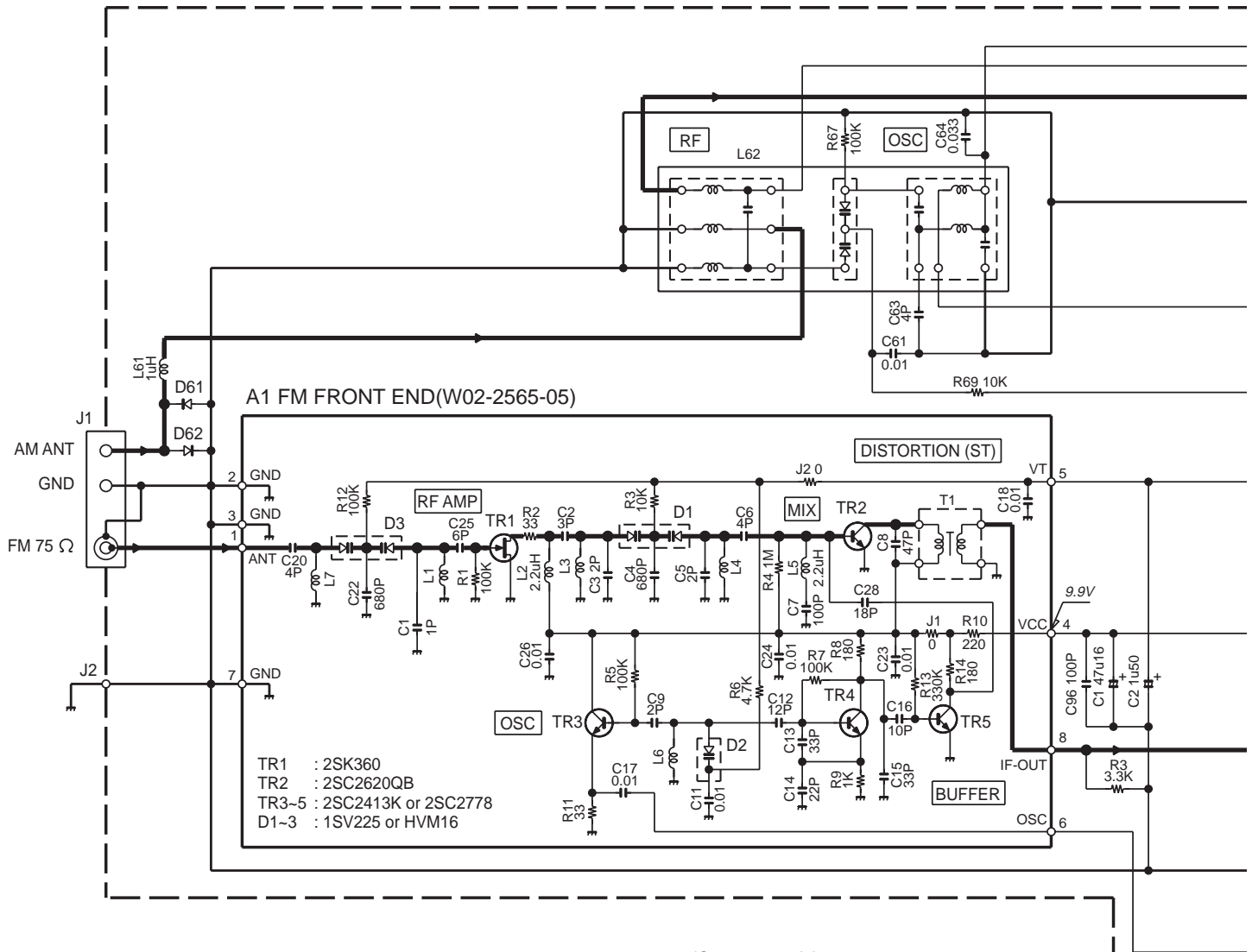

- TR1 : 2SK360
- TR2 : 2SC2620QB
- TR3-5 : 2SC2413K or 2SC2778
- D1-3 : 1SV225 or HVM16

VT VOLTAGE
LF: LOW FREQUENCY
HF: HIGH FREQUENCY

BAND	FREQ.	VOLTAGE(VT)
FM	LF	2.1V
	HF	7.5V
AM	LF	1.1V
	HF	4.6V

- IC1 : LA1836
- IC2 : LC72131
- IC3 : M5223FP
- Q1,2 : 2SC2714(R,O)
- Q3,81,103 : 2SB1218A(Q,R) or 2SA1576(R,S)
- Q31,32 : 2SD1819A(Q,R) or 2SC4081(R,S)
- Q101,102 : 2SD2114K
- D1,33,61,62 : 1SS133 or HSS104
- D31 : MTZJ8.2(B) or HZS8.2N(B2)
- D32 : MA111
- D81 : MTZJ5.1(B) or HZS5.1N(B2)
- D101 : MTZJ3.3(B) or HZS3.3N(B2)

CAUTION: For continued safety, replace safety critical components only with manufacturer's recommended parts (refer to parts list). Δ indicates safety critical components. For continued protection against risk of fire, replace only with same type and rating fuse(s). To reduce the risk of electric shock, leakage-current or resistance measurements shall be carried out (exposed parts are acceptably insulated from the supply circuit) before the appliance is returned to the customer.

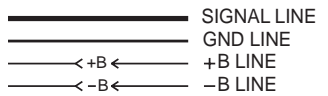

The DC voltage is an actual reading measured with a high impedance type voltmeter as the AM/FM signal generator is specified to the conditions as shown in the list below. The measurement value may vary depending on the measuring instruments used or on the product. The value shown in () is actual reading measured in the AM mode.

MODE	CARRIER	MODULATION		ANT INPUT
		FREQUENCY	DEVIATION	
FM	98MHz	1kHz	STEREO 67.5kHz 7.5kHz(Pilot)	60dB
AM	1000(999)kHz	400Hz	MONO 30% MOD	60dB

(X05-4882-70) : (E,T)TYPE

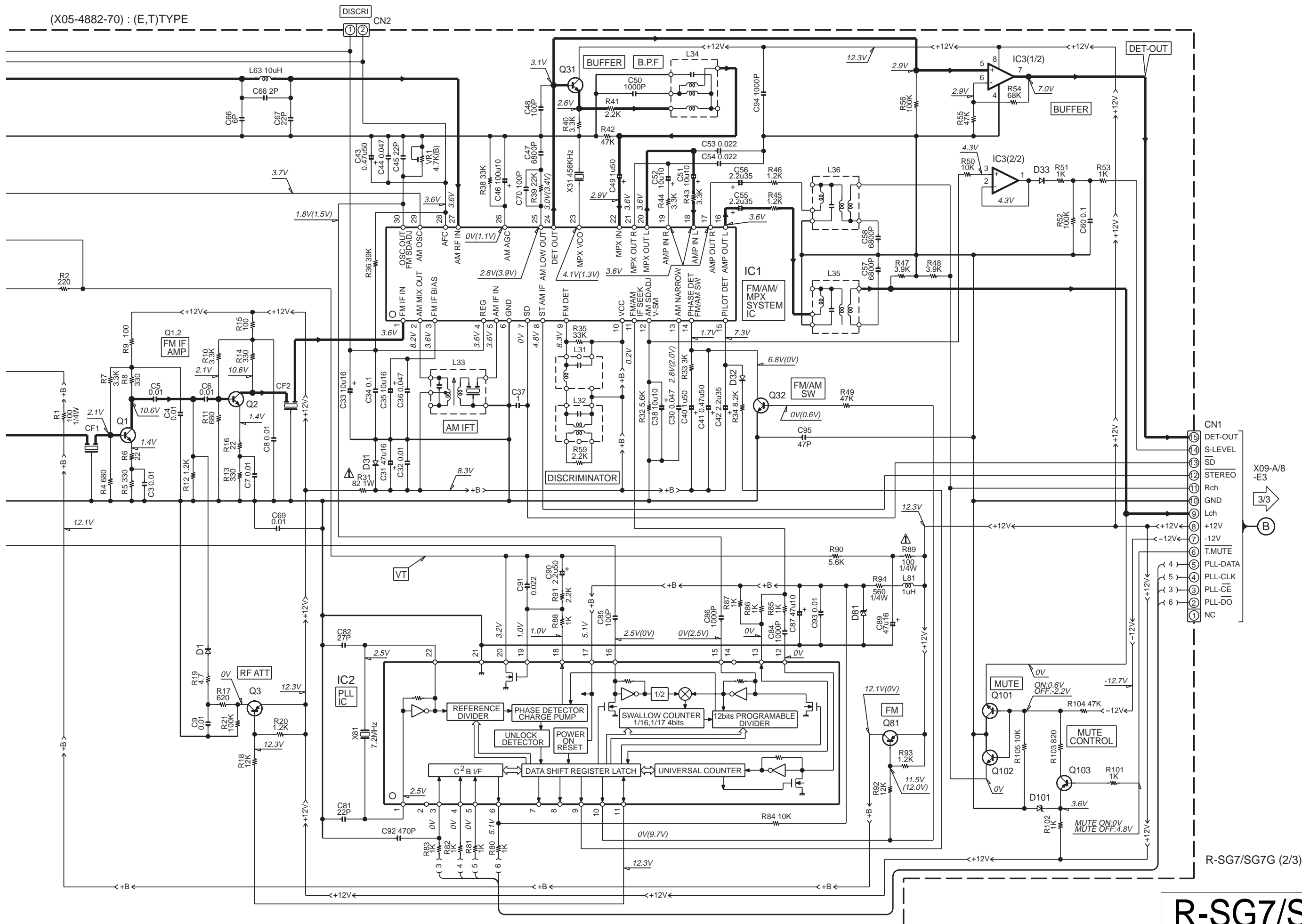

R-SG7/SG7G (2/3)

R-SG7/SG7G

KENWOOD

Y05-3960-21

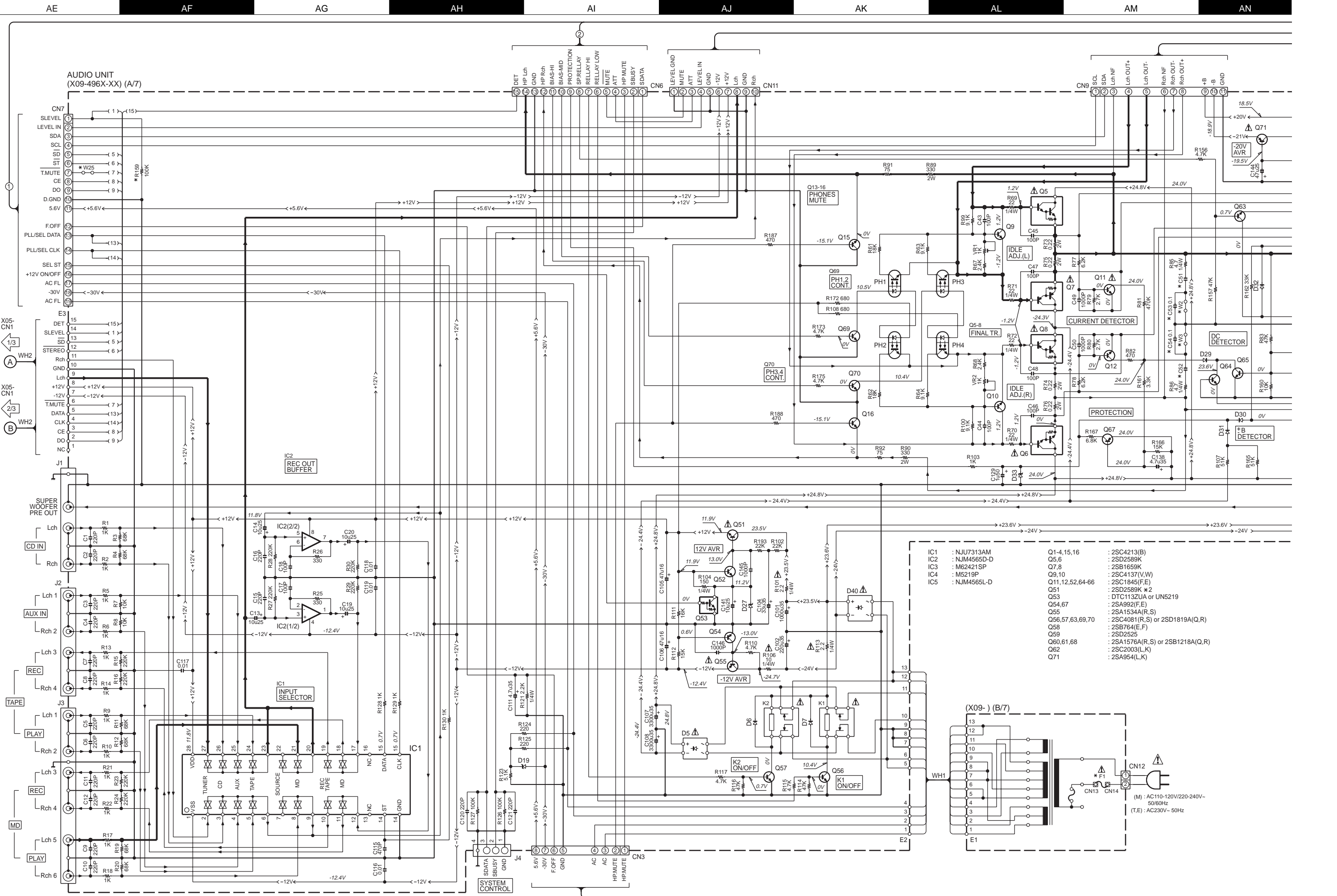

**AUDIO UNIT
(X09-496X-XX) (A/7)**

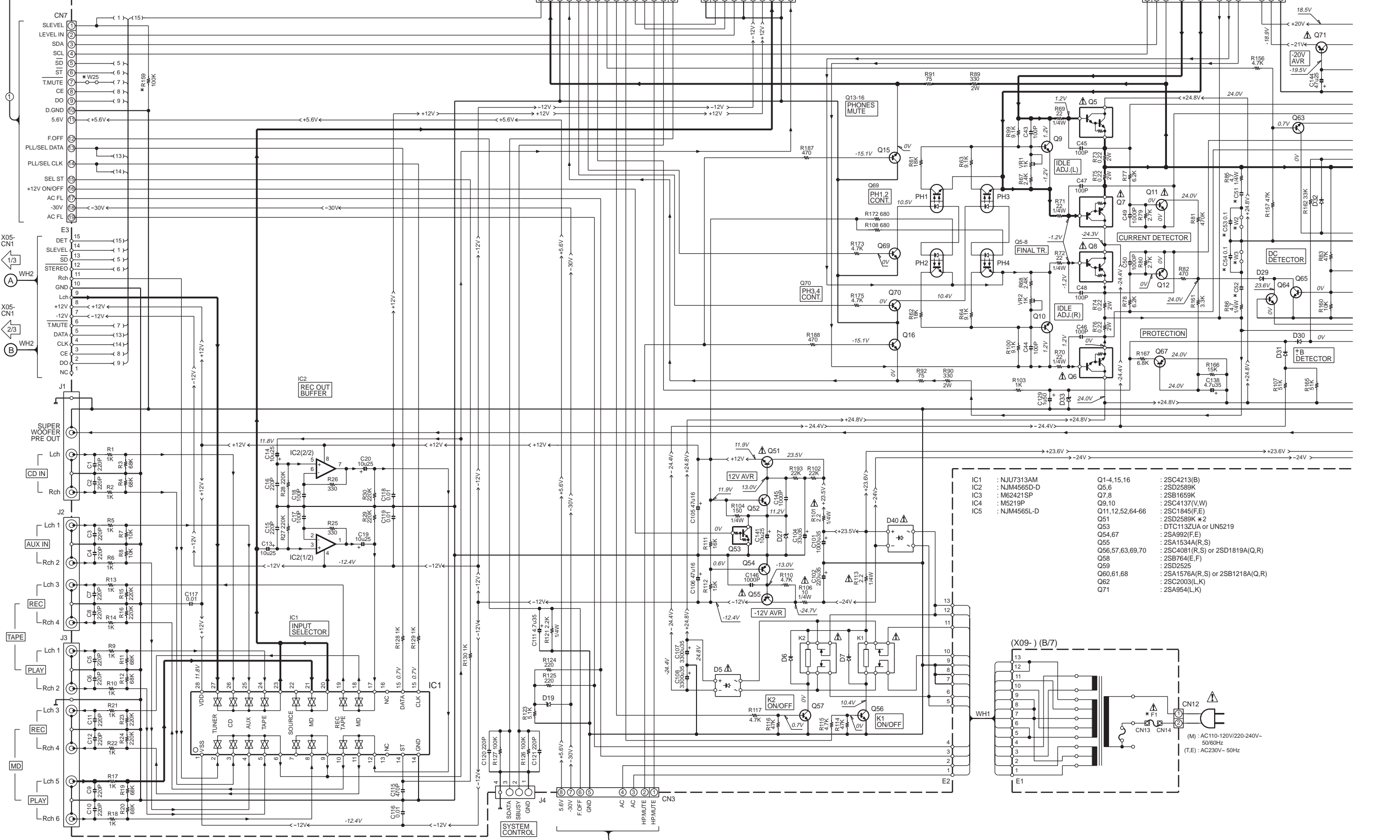

- | | | | |
|-----|--------------|-----------------|----------------------------------|
| IC1 | : NJU7313AM | Q1-4,15,16 | : 2SC4213(B) |
| IC2 | : NJM4565D-D | Q5,6 | : 2SD2589K |
| IC3 | : M62421SP | Q7,8 | : 2SB1659K |
| IC4 | : M5219P | Q9,10 | : 2SC4137(V,W) |
| IC5 | : NJM4565L-D | Q11,12,52,64-66 | : 2SC1845(F,E) |
| | | Q51 | : 2SD2589K *2 |
| | | Q53 | : DTC1132UA or UN5219 |
| | | Q54,67 | : 2SA992(F,E) |
| | | Q55 | : 2SA1534A(R,S) |
| | | Q56,57,63,69,70 | : 2SC4081(R,S) or 2SD1819A(Q,R) |
| | | Q58 | : 2SB764(E,F) |
| | | Q59 | : 2SD2525 |
| | | Q60,61,68 | : 2SA1576A(R,S) or 2SB1218A(Q,R) |
| | | Q62 | : 2SC2003(L,K) |
| | | Q71 | : 2SA954(L,K) |

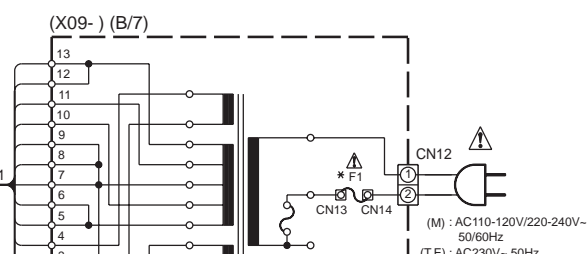

(M) : AC110-120V/220-240V-50/60Hz
(T,E) : AC230V-50Hz

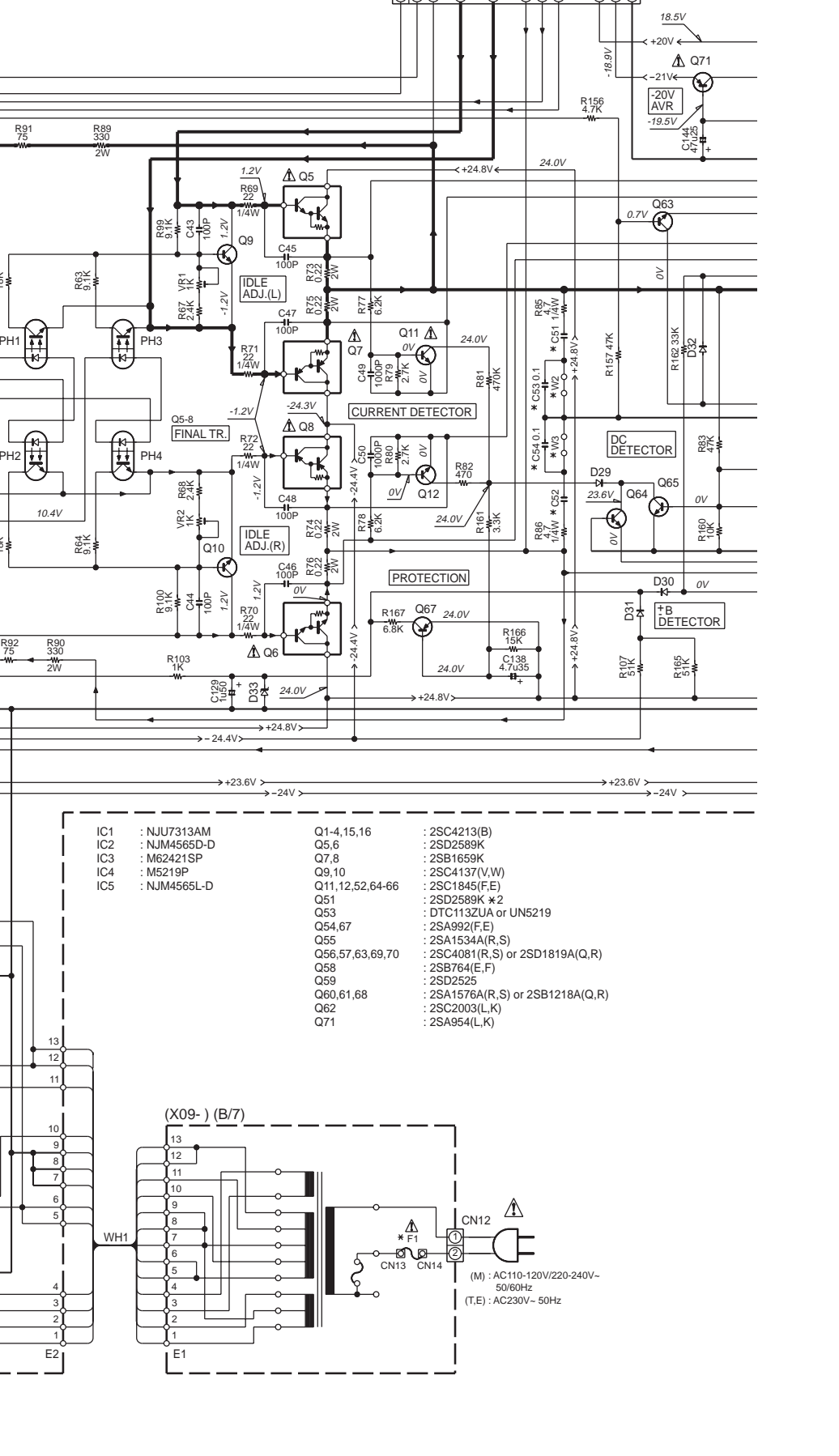
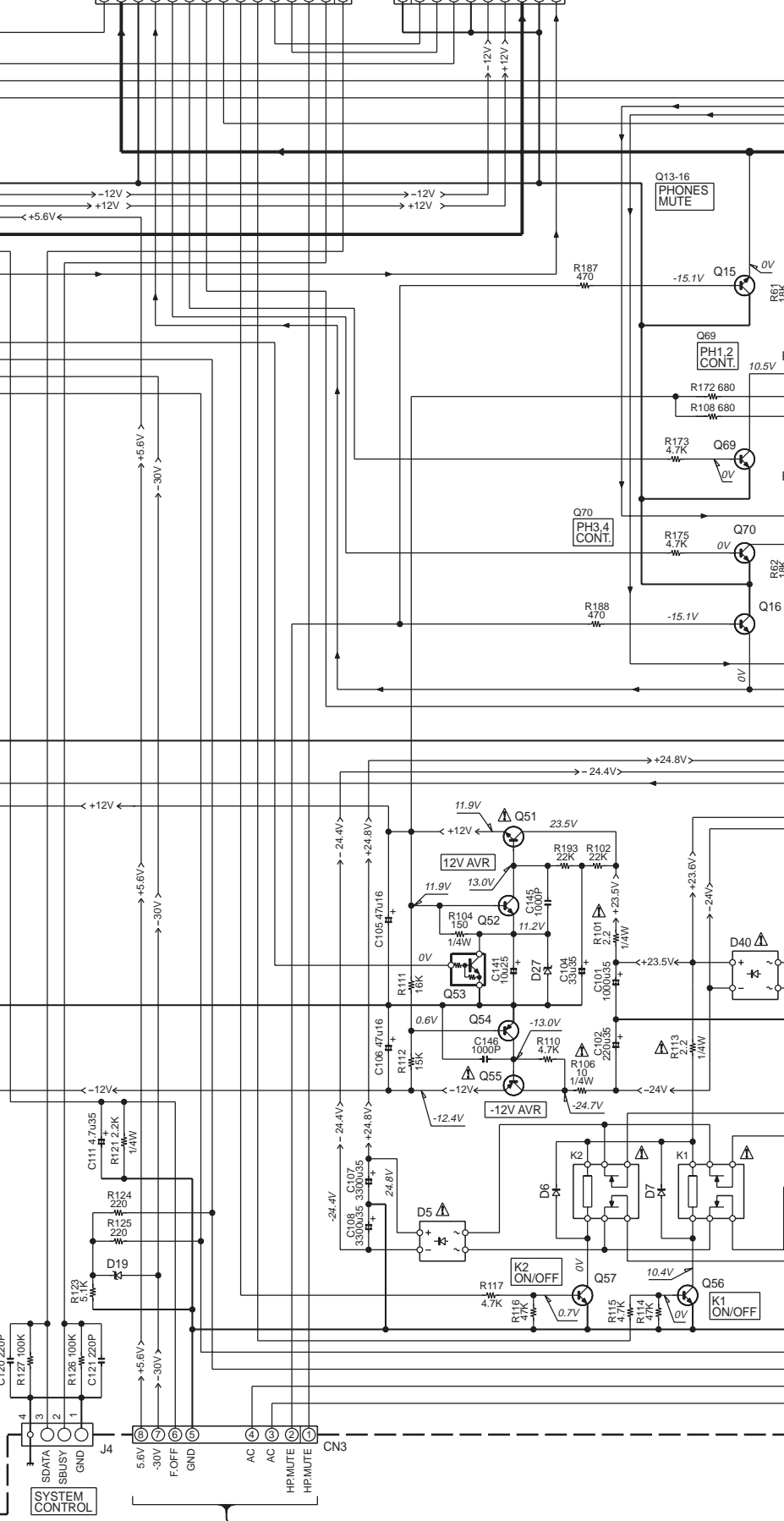
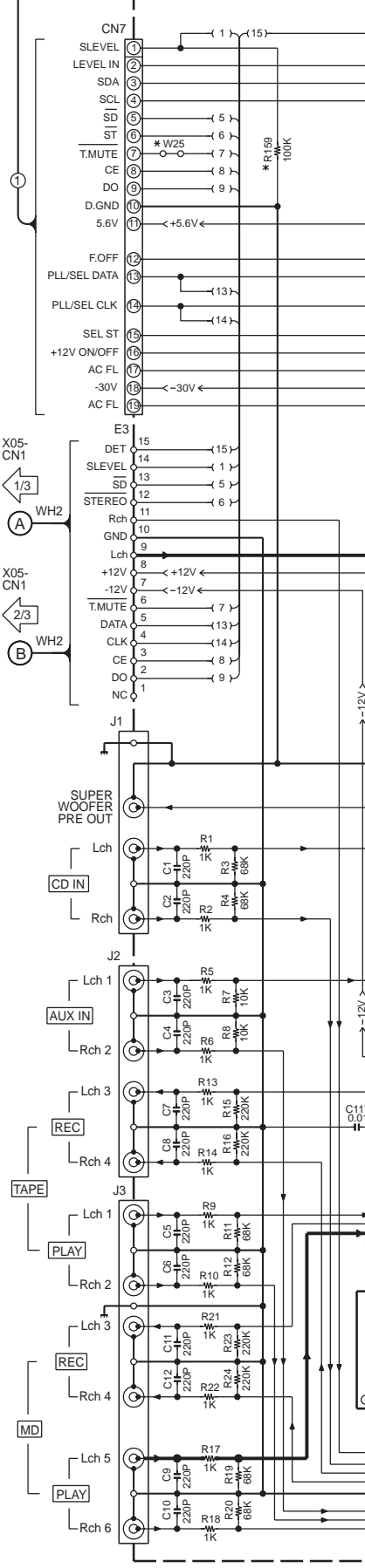

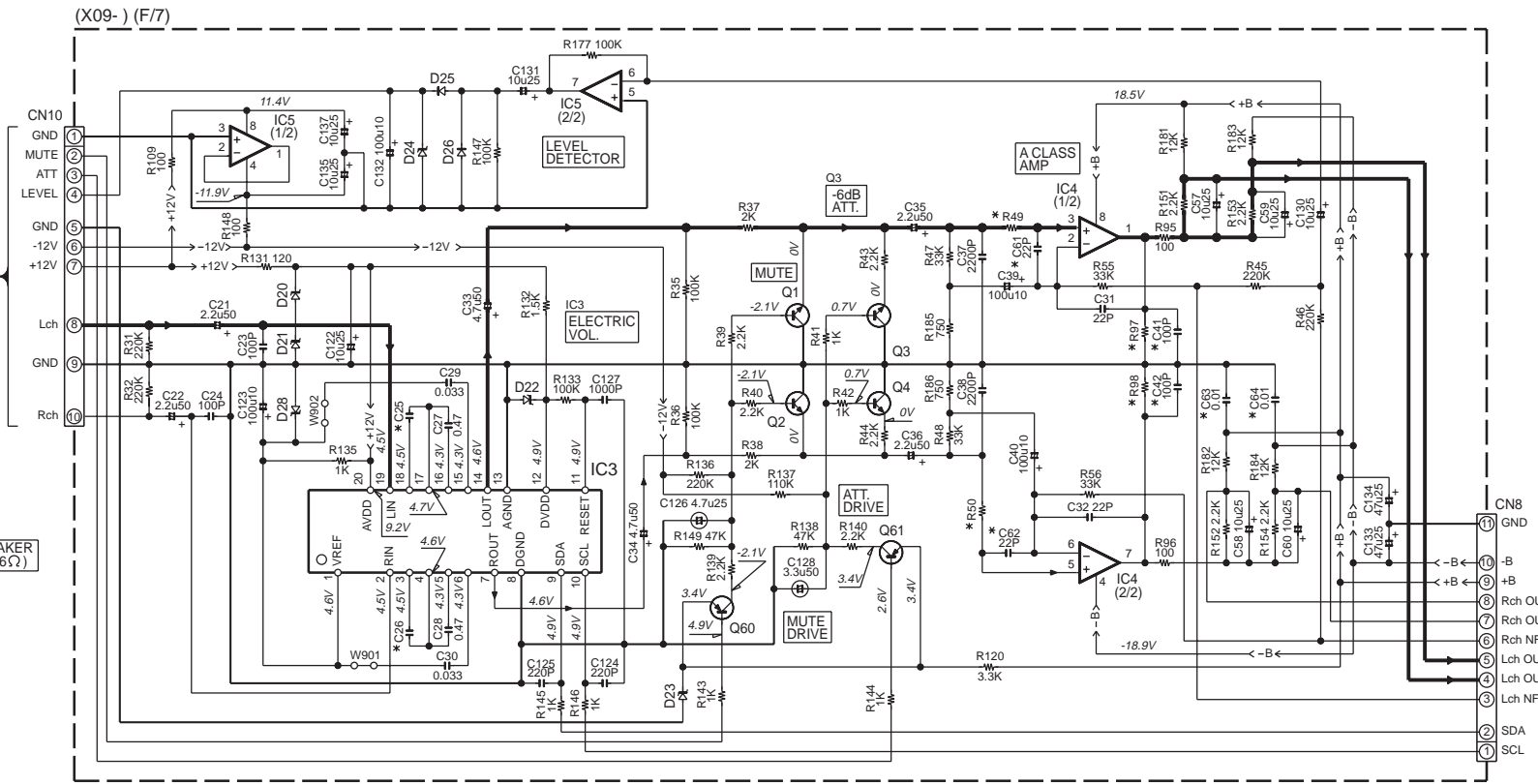
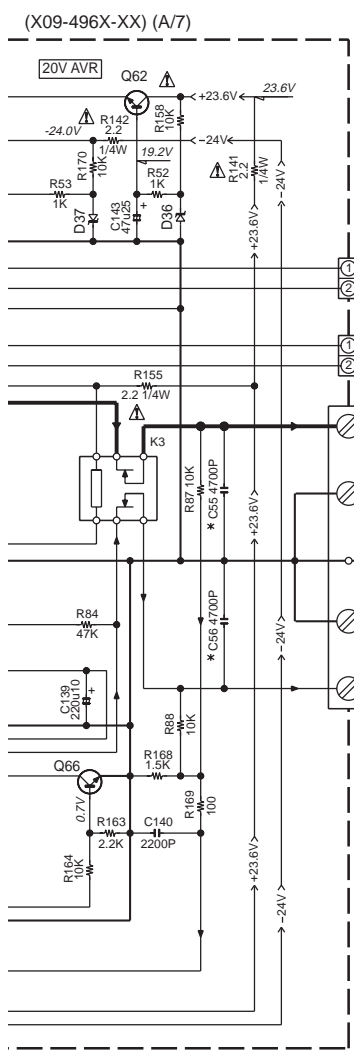

R-SG7 (X09-496X-XX)

DESTINATION	COUNTRY	ABB.	UNIT No.	W2,3	W25	C25, 26	C41, 42	C51, 52	C53-56, 61-64	R49, 50	R97, 98	R159	F1	J5
JAPAN	J	J	0-01	YES	NO	0.022	YES	0.047	NO	100	10K	YES	1A 125V	E70-0034
U.K.	T	T												
EUROPE	E	E	2-72	NO	YES	0.068	NO	0.1	YES	1K	3.3K	NO	T 400mA L 250V	E70-0061

R-SG7G (X09-496X-XX)

DESTINATION	COUNTRY	ABB.	UNIT No.	W2,3	W25	C25, 26	C41, 42	C51, 52	C53-56, 61-64	R49, 50	R97, 98	R159	F1	J5
JAPAN	J	J	0-01	YES	NO	0.022	YES	0.047	NO	100	10K	YES	1A 125V	E70-0034
GENERAL MARKET	M	M	0-22	YES	NO	0.022	YES	0.047	NO	100	3.3K	NO	800mA L 250V	E70-0061

- D5 : D3SBA20F03 or RBV-402LFA
- D6,7,31 : MA111
- D8,9 : 1SS131 or HSS104A
- D10-14 : S5688B or 1SR139-400
- D15,16 : MTZJ16(B) HZS16N(B2)
- D17,19 : MTZJ6.2(B) HZS6.2N(B2)
- D18 : MTZJ6.8(B) HZS6.8N(B2)
- D20,21,24,28,33 : MTZJ4.7(B) HZS4.7N(B)
- D22 : MTZJ5.1(B) HZS5.1N(B2)
- D23,39 : MTZJ3.9(B) HZS3.9N(B2)
- D25,26,29,30,32 : 1SS133 or HSS104
- D27 : MTZJ11(B) HZS11N(B2)
- D36,37 : MTZJ20 HZS20N(B)
- D40 : KBP02ML-6127

(X09-) (C/7)

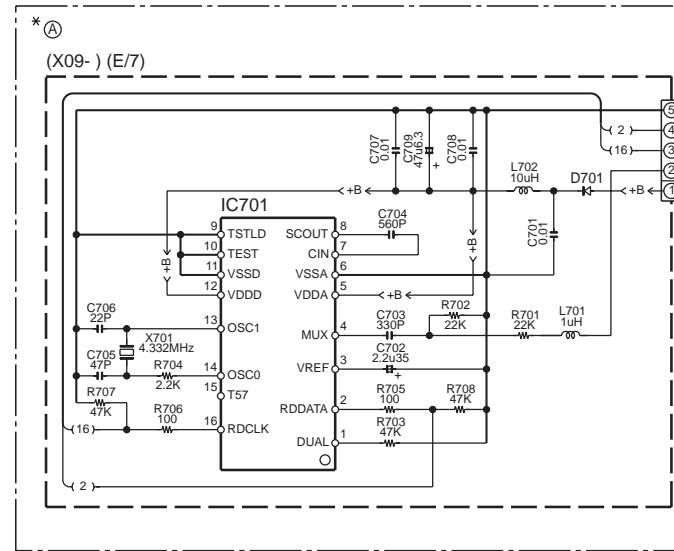
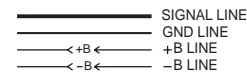
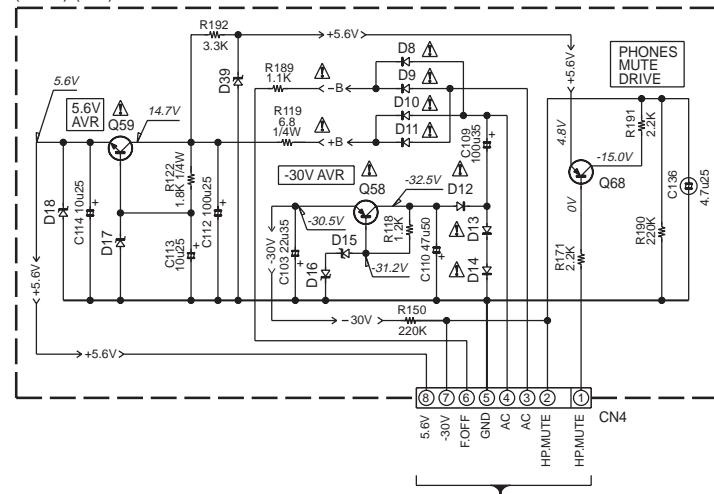

DISPLAY UNIT (X09-496X-XX) (D/7)

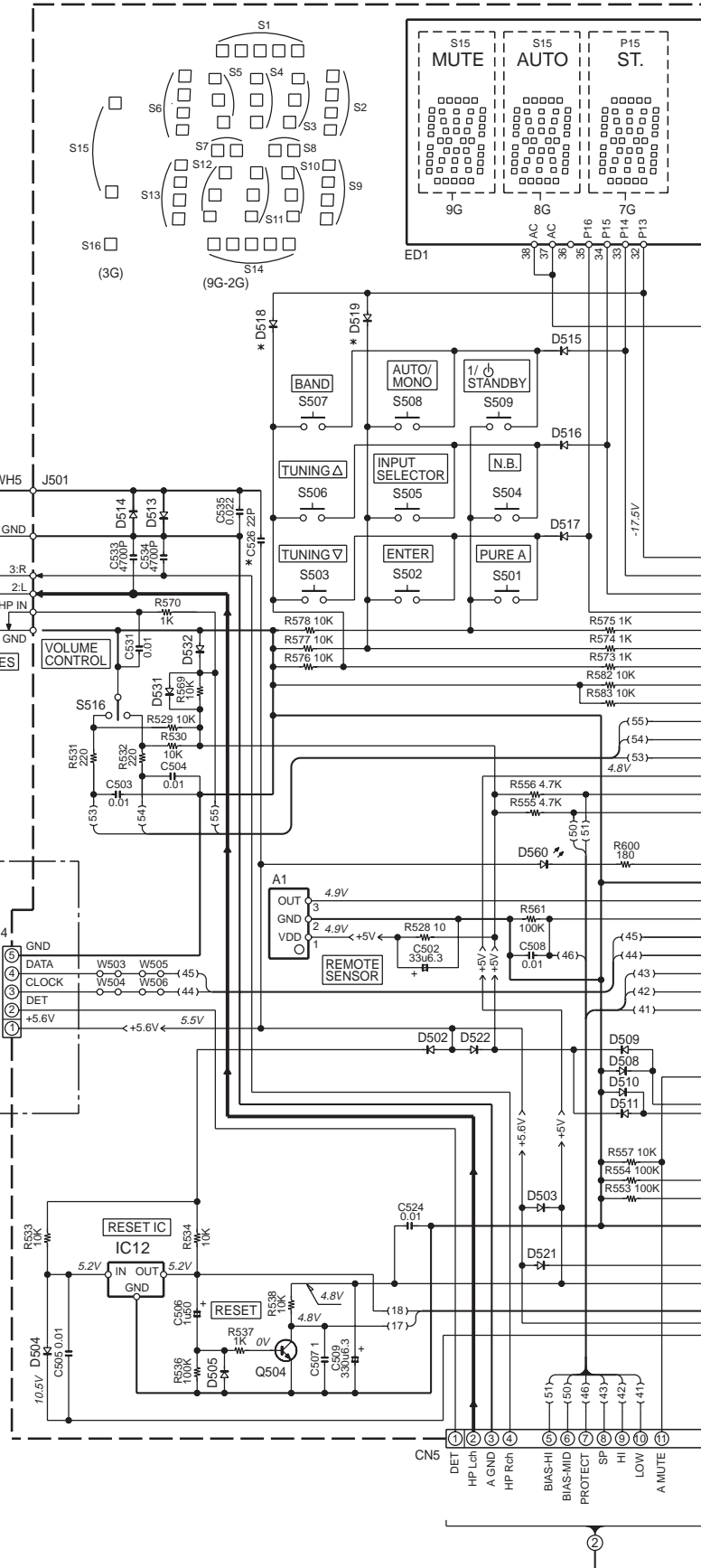

CAUTION: For continued safety, replace safety critical components only with manufacturer's recommended parts (refer to parts list). Δ indicates safety critical components. For continued protection against risk of fire, replace only with same type and rating fuse(s). To reduce the risk of electric shock, leakage-current or resistance measurements shall be carried out (exposed parts are acceptably insulated from the supply circuit) before the appliance is returned to the customer.

The DC voltage is an actual reading measured with a high impedance type voltmeter with a cassette loaded at playback mode. The measurement value may vary depending on the measuring instruments used or on the product. Bias circuit DC voltage is measured while in the record mode.

R-SG7 (X09-496X-XX)

DESTINATION	COUNTRY	ABB.	UNIT No.	(A)	(B)	D512, 519	D518	C526, 528	C529	W503-506
JAPAN	J		0-01	NO	NO	NO	NO	NO	NO	NO
JAPAN	J2		0-01	NO	NO	NO	NO	NO	NO	NO
U.K.	T		2-72	YES	YES	NO	NO	YES	YES	YES
EUROPE	E		2-72	YES	YES	NO	NO	YES	YES	YES

R-SG7G (X09-496X-XX)

DESTINATION	COUNTRY	ABB.	UNIT No.	(A)	(B)	D512, 519	D518	C526, 528	C529	W503-506
JAPAN	J		0-01	NO	NO	NO	NO	NO	NO	NO
GENERAL MARKET	M		0-22	NO	NO	YES	NO	NO	NO	NO

(X09-496X-XX) (D/7)

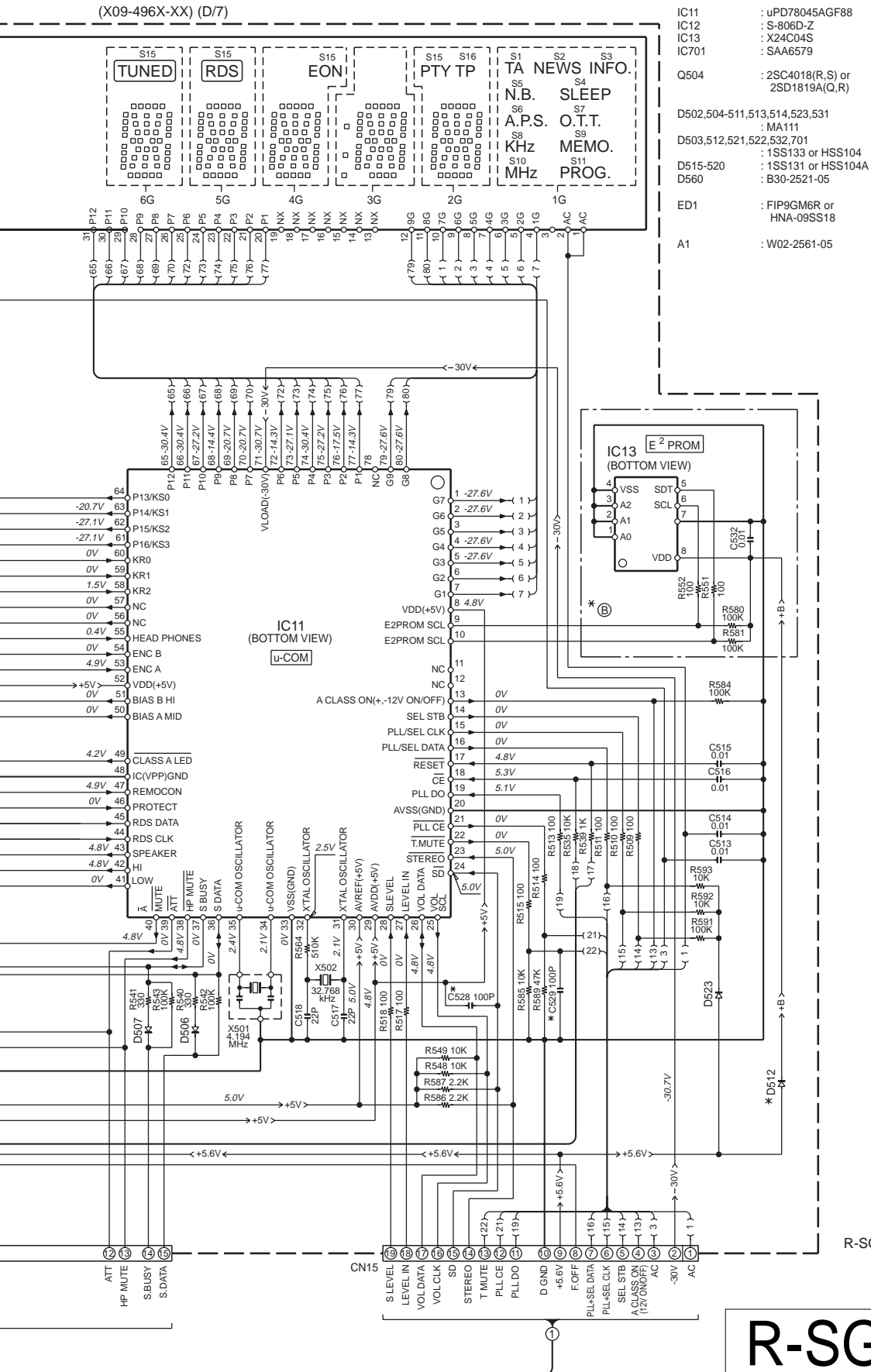

R-SG7/SG7G

Y05-3960-21

KENWOOD

Parts with exploded numbers larger than 700 are not supplied.

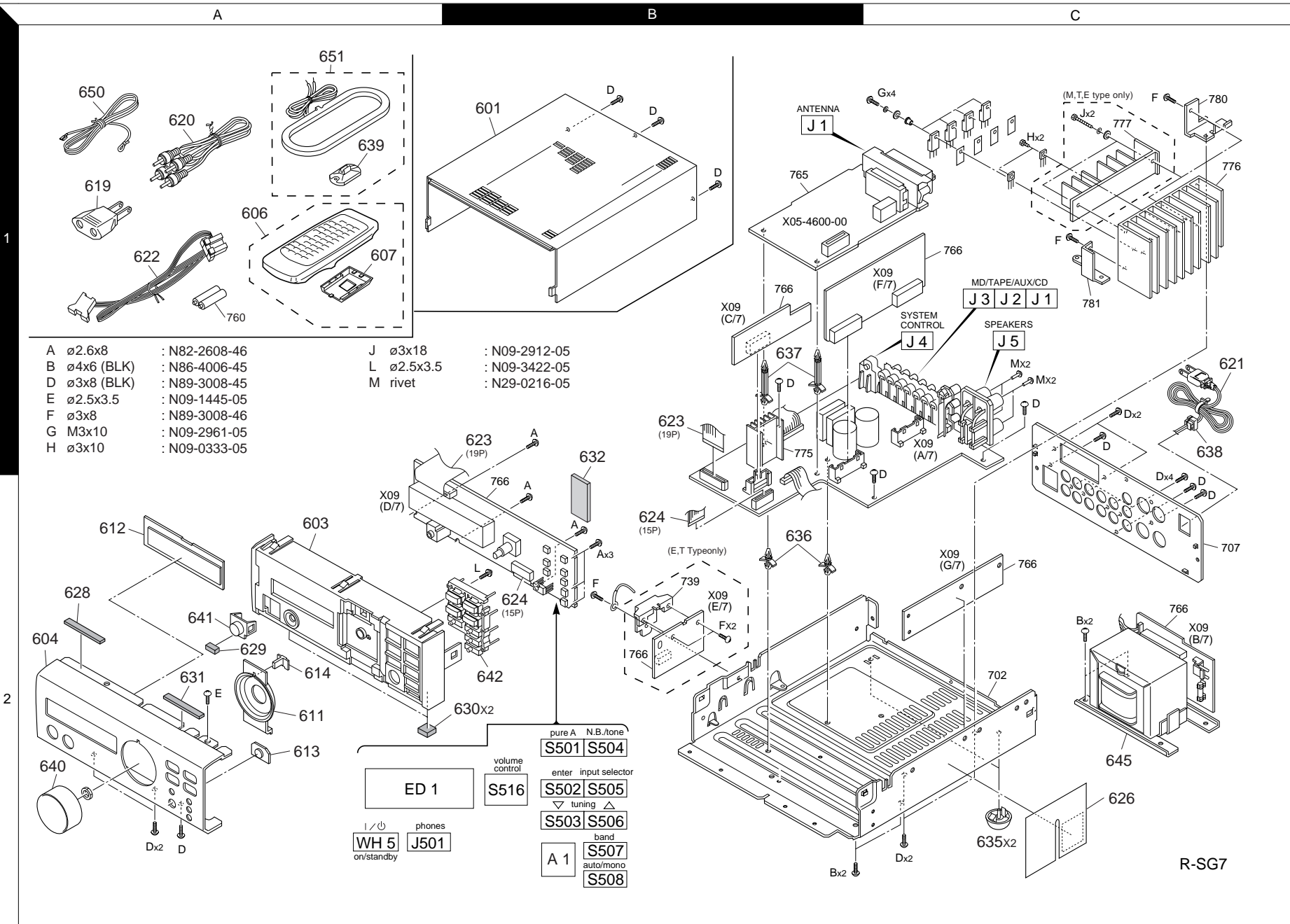

R-SG7

* New Parts
 Parts without **Parts No.** are not supplied.
 Les articles non mentionnés dans le **Parts No.** ne sont pas fournis.
 Teile ohne **Parts No.** werden nicht geliefert.

①

Ref. No	Add-ress	New Parts	Parts No.	Description	Desti-nation	Re-marks
R-SG7/SG7G M: R-SG7G						
601	1B	*	A01-3470-11	METALLIC CABINET		
603	2A		A22-1783-11	SUB PANEL	TE	
603	2A	*	A22-1826-01	SUB PANEL	M	
604	2A	*	A60-1677-03	PANEL	TE	
604	2A	*	A60-1678-03	PANEL	M	
606	1A		A70-1154-05	REMOTE CONTROLLER ASSY	M	
606	1A		A70-1155-05	REMOTE CONTROLLER ASSY	TE	
607	1A		A09-0356-08	BATTERY COVER		
611	2A	*	B07-2457-03	ESCUTCHEON		
612	2A		B10-2373-03	FRONT GLASS		
613	2A		B12-0320-04	INDICATOR		
614	2A	*	B12-0368-04	INDICATOR		
-			B46-0310-03	WARRANTY CARD	TE	
-		*	B58-1647-04	CAUTION CARD		
-		*	B60-4358-00	INSTRUCTION MANUAL(EN)	T	
-		*	B60-4359-00	INSTRUCTION MANUAL(FR)	E	
-		*	B60-4360-00	INSTRUCTION MANUAL(GE)	E	
-		*	B60-4361-00	INSTRUCTION MANUAL(NE)	E	
-		*	B60-4362-00	INSTRUCTION MANUAL(IT)	E	
-		*	B60-4363-00	INSTRUCTION MANUAL(ES)	E	
-		*	B60-4364-00	INSTRUCTION MANUAL(TC)	M	
Δ 619	1A		E03-0115-05	AC PLUG ADAPTER	M	
Δ 620	1A		E30-0615-05	AUDIO CORD		
Δ 621	1C		E30-2592-15	AC POWER CORD	ME	
Δ 621	1C		E30-2721-05	AC POWER CORD	T	
622	1A		E30-2628-05	CORD WITH CONNECTOR		
623	1B		E35-2007-05	FLAT CABLE (19P)	M	
623	1B		E35-2077-05	FLAT CABLE (19P)	TE	
624	2B		E35-2078-05	FLAT CABLE (15P)		
626	2C		F19-1080-04	SHIELDING PLATE		
628	2A		G11-2389-04	CUSHION		
629	2A		G11-2390-04	CUSHION		
630	2B		G11-2391-04	CUSHION		
631	2A		G11-2403-04	CUSHION		
632	1B		G11-2417-04	CUSHION		
-			H10-7462-02	POLYSTYRENE FOAMED FIXTURE		
-			H10-7463-02	POLYSTYRENE FOAMED FIXTURE		
-			H12-2298-14	PACKING FIXTURE		
-			H25-1579-04	PROTECTION BAG	T	
-			H25-1581-04	PROTECTION BAG	ME	
-			H25-1595-04	PROTECTION BAG	T	
-		*	H50-3414-04	ITEM CARTON CASE		
-		*	H50-3417-14	ITEM CARTON CASE	E	
-		*	H50-3453-04	ITEM CARTON CASE	M	
635	2C		J02-0370-05	FOOT	T	
636	2B		J19-3331-05	UNIT HOLDER		
637	1B		J19-5877-05	UNIT HOLDER		
638	1C		J42-0083-05	POWER CORD BUSHING		
639	1A		J19-3645-05	AMTENNA STAND		
-			J61-0307-05	WIRE BAND		

L : Scandinavia K : USA P : Canada R : Mexico C : China I : Malaysia
 Y : PX(Far East, Hawaii) T : England E : Europe G : Germany V : China (Shanghai)
 Y : AAFES(Europe) X : Australia Q : Russia H : Korea M : Other Areas Δ indicates safety critical components.

* New Parts
 Parts without **Parts No.** are not supplied.
 Les articles non mentionnés dans le **Parts No.** ne sont pas fournis.
 Teile ohne **Parts No.** werden nicht geliefert.

②

Ref. No	Add-ress	New Parts	Parts No.	Description	Desti-nation	Re-marks
640	2A		K29-6358-14	KNOB		
641	2A		K29-6741-04	KNOB		
642	2B	*	K29-7570-03	KNOB		
Δ 645	2C		L07-2386-05	POWER TRANSFORMER	TE	
Δ 645	2C		L07-2415-05	POWER TRANSFORMER	M	
650	1A		T90-0801-05	LEAD WIRE ANTENNA	M	
650	1A		T90-0809-05	LEAD WIRE ANTENNA	TE	
651	1A		T90-0833-05	LOOP ANTENNA		
TUNER UNIT (X05-4860-71)						
C1	.2		CK73FB1H103K	CHIP C	0.010UF	K
C3			CC73FCH1H040C	CHIP C	4.0PF	C
C4			CK73FB1H103K	CHIP C	0.010UF	K
C5			CK73FB1H102K	CHIP C	1000PF	K
C8			CK73FB1H103K	CHIP C	0.010UF	K
C9			CE04LW1C100M	ELECTRO	10UF	16WV
C10			CK73FB1H473K	CHIP C	0.047UF	K
C11			CE04LW1H010M	ELECTRO	1.0UF	50WV
C12			CE04LW1H2R2M	ELECTRO	2.2UF	50WV
C13			CK73FB1H102K	CHIP C	1000PF	K
C14			CE04LW1H010M	ELECTRO	1.0UF	50WV
C15			CC73FCH1H220J	CHIP C	22PF	J
C16			CE04LW1C100M	ELECTRO	10UF	16WV
C17			CK73FB1H562K	CHIP C	5600PF	K
C18			CK73FB1H102K	CHIP C	1000PF	K
C19			CE04HW1E4R7M	NP-ELEC	4.7UF	25WV
C20			CK73FB1E104K	CHIP C	0.10UF	K
C21	.22		CQ93FMG1H113J	MYLAR	0.011UF	J
C23			CE04LW1H010M	ELECTRO	1.0UF	50WV
C25			CE04LW1C100M	ELECTRO	10UF	16WV
C26			CE04LW1C470M	ELECTRO	47UF	16WV
C27			CE04LW1H010M	ELECTRO	1.0UF	50WV
C28			CQ93FMG1H223J	MYLAR	0.022UF	J
C29			CE04LW1H2R2M	ELECTRO	2.2UF	50WV
C30			CE04LW1C101M	ELECTRO	100UF	16WV
C31			CE04LW1A470M	ELECTRO	47UF	10WV
C32			CK73FB1H103K	CHIP C	0.010UF	K
C33			CC73FSL1H101J	CHIP C	100PF	J
C34	.35		CK73FB1H102K	CHIP C	1000PF	K
C36			CC73FCH1H270J	CHIP C	27PF	J
C37			CC73FCH1H220J	CHIP C	22PF	J
C38			CK73FB1H471K	CHIP C	470PF	K
C52			CC73FSL1H470J	CHIP C	47PF	J
C57	-60		CE04LW1C100M	ELECTRO	10UF	16WV
C63			CC73FCH1H220J	CHIP C	22PF	J
CN1			E40-4609-05	PIN ASSY		
J1			E20-0476-05	LOCK TERMINAL BOARD(4P)		
J1			E70-0051-05	LOCK TERMINAL BOARD		
J2			F10-0945-04	SHIELDING PLATE		
CF1	.2		L72-0531-05	CERAMIC FILTER		
CF3			L72-0593-05	CERAMIC FILTER		
L1			L39-1348-05	COMBINATION COIL		
L2			L30-0911-05	AM IFT		
L3	.4		L40-1091-17	SMALL FIXED INDUCTOR(1UH)		

L : Scandinavia K : USA P : Canada R : Mexico C : China I : Malaysia
 Y : PX(Far East, Hawaii) T : England E : Europe G : Germany V : China (Shanghai)
 Y : AAFES(Europe) X : Australia Q : Russia H : Korea M : Other Areas Δ indicates safety critical components.

PARTS LIST

R-SG7/SG7G

* New Parts

Parts without **Parts No.** are not supplied.Les articles non mentionnés dans le **Parts No.** ne sont pas fournis.Teile ohne **Parts No.** werden nicht geliefert.

③

Ref. No	Add-ress	New Parts	Parts No.	Description	Desti-nation	Re-marks
X1 X2			L77-1122-05 L78-0637-05	CRYSTAL RESONATOR(7.2MHZ) RESONATOR (456KHZ)		
R1			RK73FB2A332J	CHIP R 3.3K J 1/10W		
R2			RK73FB2A681J	CHIP R 680 J 1/10W		
R3			RK73FB2A5R6J	CHIP R 5.6 J 1/10W		
R4 ,5			RK73FB2A331J	CHIP R 330 J 1/10W		
R6			RK73FB2A101J	CHIP R 100 J 1/10W		
R7			RK73FB2A473J	CHIP R 47K J 1/10W		
R8			RK73FB2A331J	CHIP R 330 J 1/10W		
R11			RK73FB2A472J	CHIP R 4.7K J 1/10W		
R13			RK73FB2A473J	CHIP R 47K J 1/10W		
R15 ,16			RK73FB2A393J	CHIP R 39K J 1/10W		
R17			RK73FB2A271J	CHIP R 270 J 1/10W		
R18			RK73FB2A302J	CHIP R 3.0K J 1/10W		
R19			RK73FB2A822J	CHIP R 8.2K J 1/10W		
R20 -23			RK73FB2A102J	CHIP R 1.0K J 1/10W		
R24			RK73FB2A562J	CHIP R 5.6K J 1/10W		
Δ R25			RD14NB2E101J	RD 100 J 1/4W		
Δ R26			RD14NB2E561J	RD 560 J 1/4W		
R27			RK73FB2A102J	CHIP R 1.0K J 1/10W		
R28			RK73FB2A103J	CHIP R 10K J 1/10W		
R29 ,30			RK73FB2A102J	CHIP R 1.0K J 1/10W		
R31			RK73FB2A103J	CHIP R 10K J 1/10W		
R32			RK73FB2A122J	CHIP R 1.2K J 1/10W		
R33			RK73FB2A123J	CHIP R 12K J 1/10W		
Δ R41			RS14KB3A181J	FL-PROOF RS 180 J 1W		
Δ R42			RD14NB2E820J	RD 82 J 1/4W		
Δ R43			RD14NB2E221J	RD 220 J 1/4W		
R44			RK73FB2A101J	CHIP R 100 J 1/10W		
R46			RK73FB2A104J	CHIP R 100K J 1/10W		
R48			RK73FB2A473J	CHIP R 47K J 1/10W		
R51 -54			RK73FB2A473J	CHIP R 47K J 1/10W		
R55 ,56			RK73FB2A154J	CHIP R 150K J 1/10W		
R59 ,60			RK73FB2A332J	CHIP R 3.3K J 1/10W		
VR1			R32-0038-05	SEMI FIXED VARIABLE RESISTOR		
W101-106			R92-0670-05	CHIP R 0 OHM		
W108-114			R92-0670-05	CHIP R 0 OHM		
W118			R92-0670-05	CHIP R 0 OHM		
W121			R92-0670-05	CHIP R 0 OHM		
W201-211			R92-0679-05	CHIP R 0 OHM		
D1 ,2			HSS104	DIODE		
D1 ,2			1SS133	DIODE		
D3 ,4			HZS5.1N(B2)	ZENER DIODE		
D3 ,4			MTZJ5.1(B)	ZENER DIODE		
D8			HSS104	DIODE		
D8			1SS133	DIODE		
D10			MA111	DIODE		
IC1			LA1832	ANALOGUE IC		
IC2			LC72131	MOS-IC		
IC4			NJM4565M	ANALOGUE IC		
Q1			2SC2714(R,O)	TRANSISTOR		
Q3			2SA1576A(R,S)	TRANSISTOR		
Q3			2SB1218A(Q,R)	TRANSISTOR		
Q5			2SC4081(R,S)	TRANSISTOR		

L : Scandinavia K : USA P : Canada R : Mexico C : China I : Malaysia

Y : PX(Far East, Hawaii) T : England E : Europe G : Germany V : China (Shanghai)

Y : AAFES(Europe) X : Australia Q : Russia H : Korea M : Other Areas Δ indicates safety critical components.

* New Parts

Parts without **Parts No.** are not supplied.Les articles non mentionnés dans le **Parts No.** ne sont pas fournis.Teile ohne **Parts No.** werden nicht geliefert.

④

Ref. No	Add-ress	New Parts	Parts No.	Description	Desti-nation	Re-marks
Q5			2SD1819A(Q,R)	TRANSISTOR		
A1			W02-2608-05	FM FRONT-END ASSY		
TUNER UNIT (X05-4882-70)						
C1			CE04LW1C470M	ELECTRO 47UF 16WV		
C2			CE04LW1H010M	ELECTRO 1.0UF 50WV		
C3 -8			CK73FB1H103K	CHIP C 0.010UF K		
C9			C91-0769-05	CERAMIC 0.010UF K		
C30			CK73EB1E473K	CHIP C 0.047UF K		
C31			CE04LW1C470M	ELECTRO 47UF 16WV		
C32			CK73FB1H103K	CHIP C 0.010UF K		
C33			CE04LW1C100M	ELECTRO 10UF 16WV		
C34			CK73EB1E104K	CHIP C 0.10UF K		
C35			CE04LW1C100M	ELECTRO 10UF 16WV		
C36			CK73FB1E473K	CHIP C 0.047UF K		
C37			CK73EF1E105Z	CHIP C 1.0UF Z		
C38			C90-3217-05	ELECTRO 10UF 10WV		
C40			C90-3253-05	ELECTRO 1.0UF 50WV		
C41			C90-3251-05	ELECTRO 0.47UF 50WV		
C42			C90-3240-05	ELECTRO 2.2UF 35WV		
C43			CE04LW1HR47M	ELECTRO 0.47UF 50WV		
C44			CK73FB1E473K	CHIP C 0.047UF K		
C45			CC73FCH1H220J	CHIP C 22PF J		
C46			CE04LW1A101M	ELECTRO 100UF 10WV		
C47			CK73FB1H682K	CHIP C 6800PF K		
C48			CC73FSL1H101J	CHIP C 100PF J		
C49			C90-3253-05	ELECTRO 1.0UF 50WV		
C50			CK73FB1H102K	CHIP C 1000PF K		
C51 ,52			C90-3217-05	ELECTRO 10UF 10WV		
C53 ,54			CK73FB1H223K	CHIP C 0.022UF K		
C55 ,56			C90-3240-05	ELECTRO 2.2UF 35WV		
C57 ,58			CK73FB1H682K	CHIP C 6800PF K		
C60			CK73FB1E104K	CHIP C 0.10UF K		
C61			CK73FB1H103K	CHIP C 0.010UF K		
C63			CC73FCH1H040C	CHIP C 4.0PF C		
C64			CK73FB1H333K	CHIP C 0.033UF K		
C66			CC73FCH1H060D	CHIP C 6.0PF D		
C67			CC73FCH1H220J	CHIP C 22PF J		
C68			CC73FSL1H020C	CHIP C 2.0PF C		
C69			CK73FB1H103K	CHIP C 0.010UF K		
C70			CC73FSL1H101J	CHIP C 100PF J		
C81			CC73FCH1H220J	CHIP C 22PF J		
C82			CC73FCH1H270J	CHIP C 27PF J		
C84			CK73FB1H102K	CHIP C 1000PF K		
C85			C91-0745-05	CERAMIC 100PF K		
C86			C91-0757-05	CERAMIC 1000PF K		
C87			CE04LW1A470M	ELECTRO 47UF 10WV		
C89			CE04LW1C470M	ELECTRO 47UF 16WV		
C90			CE04LW1H2R2M	ELECTRO 2.2UF 50WV		
C91			CQ92FM1H223J	MYLAR 0.022UF J		
C92			CC73FSL1H471J	CHIP C 470PF J		
C93			CK73FB1H103K	CHIP C 0.010UF K		
C94			CK73FB1H102K	CHIP C 1000PF K		
C95			CC73FCH1H470J	CHIP C 47PF J		

L : Scandinavia K : USA P : Canada R : Mexico C : China I : Malaysia

Y : PX(Far East, Hawaii) T : England E : Europe G : Germany V : China (Shanghai)

Y : AAFES(Europe) X : Australia Q : Russia H : Korea M : Other Areas Δ indicates safety critical components.

* New Parts

Parts without **Parts No.** are not supplied.
Les articles non mentionnés dans le **Parts No.** ne sont pas fournis.
Teile ohne **Parts No.** werden nicht geliefert.

5

Ref. No	Add-ress	New Parts	Parts No.	Description	Desti-nation	Re-marks
C96			CC73FSL1H101J	CHIP C 100PF J		
CN1			E40-4609-05	PIN ASSY		
CN2			E40-4871-05	PIN ASSY		
J1			E20-0321-05	LOCK TERMINAL BOARD(2P,F)		
J1			E70-0052-05	LOCK TERMINAL BOARD		
J2			F10-1053-04	SHIELDING PLATE		
CF1 ,2			L72-0536-05	CERAMIC FILTER		
L31			L30-0929-05	FM IFT		
L32			L30-0930-05	FM IFT		
L33			L30-0911-05	AM IFT		
L34			L79-1237-05	LC FILTER		
L35 ,36			L79-1236-05	LC FILTER		
L61			L40-1091-17	SMALL FIXED INDUCTOR(1UH)		
L62			L39-1348-05	COMBINATION COIL		
L63			L40-1001-17	SMALL FIXED INDUCTOR(10UH,K)		
L81			L40-1091-17	SMALL FIXED INDUCTOR(1UH)		
X31			L78-0637-05	RESONATOR (456KHZ)		
X81			L77-1122-05	CRYSTAL RESONATOR(7.2MHZ)		
R1			RD14NB2E101J	RD 100 J 1/4W		
R2			RK73EB2B221J	CHIP R 220 J 1/8W		
R3			RK73FB2A332J	CHIP R 3.3K J 1/10W		
R4			RK73FB2A681J	CHIP R 680 J 1/10W		
R5			RK73FB2A331J	CHIP R 330 J 1/10W		
R6			RK73FB2A220J	CHIP R 22 J 1/10W		
R7			RK73FB2A332J	CHIP R 3.3K J 1/10W		
R8			RK73FB2A331J	CHIP R 330 J 1/10W		
R10			RK73FB2A332J	CHIP R 3.3K J 1/10W		
R11			RK73FB2A681J	CHIP R 680 J 1/10W		
R12			RK73FB2A122J	CHIP R 1.2K J 1/10W		
R13 ,14			RK73FB2A331J	CHIP R 330 J 1/10W		
R15			RK73FB2A101J	CHIP R 100 J 1/10W		
R16			RK73FB2A220J	CHIP R 22 J 1/10W		
R17			RK73FB2A621J	CHIP R 620 J 1/10W		
R18			RK73FB2A123J	CHIP R 12K J 1/10W		
R19			RK73FB2A4R7J	CHIP R 4.7 J 1/10W		
R20			RK73FB2A122J	CHIP R 1.2K J 1/10W		
R31			RS14KB3A820J	FL-PROOF RS 82 J 1W		
R32			RK73EB2B562J	CHIP R 5.6K J 1/8W		
R33			RK73FB2A302J	CHIP R 3.0K J 1/10W		
R34			RK73FB2A822J	CHIP R 8.2K J 1/10W		
R35			RK73FB2A333J	CHIP R 33K J 1/10W		
R36			RK73FB2A393J	CHIP R 39K J 1/10W		
R38			RK73FB2A333J	CHIP R 33K J 1/10W		
R39			RK73FB2A223J	CHIP R 22K J 1/10W		
R40			RK73FB2A332J	CHIP R 3.3K J 1/10W		
R41			RK73FB2A222J	CHIP R 2.2K J 1/10W		
R42			RK73FB2A473J	CHIP R 47K J 1/10W		
R43 ,44			RK73FB2A332J	CHIP R 3.3K J 1/10W		
R45 ,46			RK73FB2A122J	CHIP R 1.2K J 1/10W		
R47 ,48			RK73FB2A392J	CHIP R 3.9K J 1/10W		
R49			RK73FB2A473J	CHIP R 47K J 1/10W		
R51			RK73FB2A102J	CHIP R 1.0K J 1/10W		
R52			RK73FB2A104J	CHIP R 100K J 1/10W		

L : Scandinavia K : USA P : Canada R : Mexico C : China I : Malaysia
Y : PX(Far East, Hawaii) T : England E : Europe G : Germany V : China (Shanghai)
Y : AAFES(Europe) X : Australia Q : Russia H : Korea M : Other Areas Δ indicates safety critical components.

* New Parts

Parts without **Parts No.** are not supplied.
Les articles non mentionnés dans le **Parts No.** ne sont pas fournis.
Teile ohne **Parts No.** werden nicht geliefert.

6

Ref. No	Add-ress	New Parts	Parts No.	Description	Desti-nation	Re-marks
R53			RK73FB2A102J	CHIP R 1.0K J 1/10W		
R54			RK73FB2A683J	CHIP R 68K J 1/10W		
R55			RK73FB2A473J	CHIP R 47K J 1/10W		
R56			RK73FB2A104J	CHIP R 100K J 1/10W		
R59			RK73FB2A222J	CHIP R 2.2K J 1/10W		
R67			RK73FB2A104J	CHIP R 100K J 1/10W		
R80			RK73EB2B102J	CHIP R 1.0K J 1/8W		
R81 -83			RK73FB2A102J	CHIP R 1.0K J 1/10W		
R84			RK73FB2A103J	CHIP R 10K J 1/10W		
R85 -88			RK73FB2A102J	CHIP R 1.0K J 1/10W		
Δ R89			RD14NB2E101J	RD 100 J 1/4W		
R90			RK73FB2A562J	CHIP R 5.6K J 1/10W		
R91			RK73FB2A222J	CHIP R 2.2K J 1/10W		
R92			RK73FB2A123J	CHIP R 12K J 1/10W		
R93			RK73FB2A122J	CHIP R 1.2K J 1/10W		
R94			RD14NB2E561J	RD 560 J 1/4W		
R101,102			RK73FB2A102J	CHIP R 1.0K J 1/10W		
R103			RK73FB2A821J	CHIP R 820 J 1/10W		
R104			RK73FB2A473J	CHIP R 47K J 1/10W		
R105			RK73FB2A103J	CHIP R 10K J 1/10W		
VR1			R32-0036-05	SEMI FIXED VARIABLE RESISTOR		
W51 -54			R92-0670-05	CHIP R 0 OHM		
W56 -58			R92-0679-05	CHIP R 0 OHM		
W59 -61			R92-0670-05	CHIP R 0 OHM		
W62 -67			R92-0679-05	CHIP R 0 OHM		
W69 -71			R92-0679-05	CHIP R 0 OHM		
W77			R92-0670-05	CHIP R 0 OHM		
W80			R92-0670-05	CHIP R 0 OHM		
W81			R92-0679-05	CHIP R 0 OHM		
W83 ,84			R92-0679-05	CHIP R 0 OHM		
D1			HSS104	DIODE		
D1			1SS133	DIODE		
D31			HZS8.2N(B2)	ZENER DIODE		
D31			MTZJ8.2(B)	ZENER DIODE		
D32			MA111	DIODE		
D33			HSS104	DIODE		
D33			1SS133	DIODE		
D61 ,62			HSS104	DIODE		
D61 ,62			1SS133	DIODE		
D81			HZS5.1N(B2)	ZENER DIODE		
D81			MTZJ5.1(B)	ZENER DIODE		
D101			HZS3.3N(B2)	ZENER DIODE		
D101			MTZJ3.3(B)	ZENER DIODE		
IC1			LA1836	ANALOGUE IC		
IC2			LC72131	MOS-IC		
IC3			M5223FP	IC(OP AMP X4)		
Q1 ,2			2SC2714(R,O)	TRANSISTOR		
Q3			2SA1576(R,S)	TRANSISTOR		
Q3			2SB1218A(Q,R)	TRANSISTOR		
Q31 ,32			2SC4081(R,S)	TRANSISTOR		
Q31 ,32			2SD1819A(Q,R)	TRANSISTOR		
Q81			2SA1576(R,S)	TRANSISTOR		
Q81			2SB1218A(Q,R)	TRANSISTOR		
Q101,102			2SD2114K	TRANSISTOR		
Q103			2SA1576(R,S)	TRANSISTOR		

L : Scandinavia K : USA P : Canada R : Mexico C : China I : Malaysia
Y : PX(Far East, Hawaii) T : England E : Europe G : Germany V : China (Shanghai)
Y : AAFES(Europe) X : Australia Q : Russia H : Korea M : Other Areas Δ indicates safety critical components.

PARTS LIST

R-SG7/SG7G

* New Parts
 Parts without **Parts No.** are not supplied.
 Les articles non mentionnés dans le **Parts No.** ne sont pas fournis.
 Teile ohne **Parts No.** werden nicht geliefert.

7

Ref. No	Add-ress	New Parts	Parts No.	Description	Desti-nation	Re-marks
Q103			2SB1218A(Q,R)	TRANSISTOR		
A1			W02-2565-05	FM FRONT-END ASSY		
AUDIO UNIT (X09-496X-XX)						
D560			B30-2521-05	LED(YEL•PHAI 3)		
C1 -12			CC73FSL1H221J	CHIP C	220PF	J
C13 ,14			CE04KW1E100M	ELECTRO	10UF	25WV
C15 ,16			CC73FSL1H221J	CHIP C	220PF	J
C17 ,18			CC73FSL1H101J	CHIP C	100PF	J
C19 ,20			CE04KW1E100M	ELECTRO	10UF	25WV
C21 ,22			CE04KW1H2R2M	ELECTRO	2.2UF	50WV
C23 ,24			CC73FSL1H101J	CHIP C	100PF	J
C25 ,26			CK73FB1H223K	CHIP C	0.022UF	K
C25 ,26			CK73FB1H683K	CHIP C	0.068UF	K
C27 ,28			CK73FF1C474Z	CHIP C	0.47UF	Z
C29 ,30			CK73FB1H333K	CHIP C	0.033UF	K
C31 ,32			CC73FSL1H220J	CHIP C	22PF	J
C33 ,34			CE04KW1H4R7M	ELECTRO	4.7UF	50WV
C35 ,36			CE04KW1H2R2M	ELECTRO	2.2UF	50WV
C37 ,38			CK73FB1H222K	CHIP C	2200PF	K
C39 ,40			CE04KW1A101M	ELECTRO	100UF	10WV
C41 ,42			CC73FCH1H101J	CHIP C	100PF	J
C43 ,44			CC73FSL1H101J	CHIP C	100PF	J
C45			CC45FSL1H101JM	CERAMIC	100PF	J
C46 -48			CC73FSL1H101J	CHIP C	100PF	J
C49 ,50			CC73FSL1H102J	CHIP C	1000PF	J
C51 ,52			CK73FB1E104K	CHIP C	0.10UF	K
C51 ,52			CK73FB1E473KTA	CHIP C	0.047UF	K
C53 ,54			CK73FB1E104K	CHIP C	0.10UF	K
C55 ,56			CK73FB1H472K	CHIP C	4700PF	K
C57 -60			CE04KW1E100M	ELECTRO	10UF	25WV
C61 ,62			CC73FSL1H220J	CHIP C	22PF	J
C63 ,64			CK73FB1H103K	CHIP C	0.010UF	K
C101			CE04KW1V102M	ELECTRO	1000UF	35WV
C102			CE04DW1V221M	ELECTRO	220UF	35WV
C103			CE04KW1V220M	ELECTRO	22UF	35WV
C104			CE04KW1V330M	ELECTRO	33UF	35WV
C105,106			CE04KW1C470M	ELECTRO	47UF	16WV
C107,108			C90-3743-05	ELECTRO	3300UF	35WV
C109			CE04KW1V101M	ELECTRO	100UF	35WV
C110			CE04KW1H470M	ELECTRO	47UF	50WV
C111			CE04KW1V4R7M	ELECTRO	4.7UF	35WV
C112			CE04KW1E101M	ELECTRO	100UF	25WV
C113,114			CE04KW1E100M	ELECTRO	10UF	25WV
C115			CC73FSL1H471J	CHIP C	470PF	J
C116-119			CK73FB1H103K	CHIP C	0.010UF	K
C120			CC73FSL1H221J	CHIP C	220PF	J
C121			CC45FSL1H221JM	CERAMIC	220PF	J
C122			CE04KW1E100M	ELECTRO	10UF	25WV
C123			CE04KW1A101M	ELECTRO	100UF	10WV
C124,125			CC73FSL1H221J	CHIP C	220PF	J
C126			CE04HW1E4R7M	NP-ELEC	4.7UF	25WV
C127			CC73FSL1H102J	CHIP C	1000PF	J
C128			CE04HW1H3R3M	NP-ELEC	3.3UF	50WV

L : Scandinavia K : USA P : Canada R : Mexico C : China I : Malaysia
 Y : PX(Far East, Hawaii) T : England E : Europe G : Germany V : China (Shanghai)
 Y : AAFES(Europe) X : Australia Q : Russia H : Korea M : Other Areas Δ indicates safety critical components.

* New Parts
 Parts without **Parts No.** are not supplied.
 Les articles non mentionnés dans le **Parts No.** ne sont pas fournis.
 Teile ohne **Parts No.** werden nicht geliefert.

8

Ref. No	Add-ress	New Parts	Parts No.	Description	Desti-nation	Re-marks
C129			CE04KW1H010M	ELECTRO	1.0UF	50WV
C130,131			CE04KW1E100M	ELECTRO	10UF	25WV
C132			CE04KW1A101M	ELECTRO	100UF	10WV
C133,134			C90-3237-05	ELECTRO	47UF	25WV
C135			CE04KW1E100M	ELECTRO	10UF	25WV
C136			CE04HW1E4R7M	NP-ELEC	4.7UF	25WV
C137			CE04KW1E100M	ELECTRO	10UF	25WV
C138			CE04KW1V4R7M	ELECTRO	4.7UF	35WV
C139			CE04KW1A221M	ELECTRO	220UF	10WV
C140			CK73FB1H222K	CHIP C	2200PF	K
C141			CE04KW1E100M	ELECTRO	10UF	25WV
C143,144			CE04KW1E470M	ELECTRO	47UF	25WV
C145,146			CC73FSL1H102J	CHIP C	1000PF	J
C502			C90-3211-05	ELECTRO	33UF	6.3WV
C503-505			CK73FB1H103K	CHIP C	0.010UF	K
C506			C90-3253-05	ELECTRO	1.0UF	50WV
C507			CK73EF1C105Z	CHIP C	1.0UF	Z
C508			CK73FB1H103K	CHIP C	0.010UF	K
C509			C90-3216-05	ELECTRO	330UF	6.3WV
C513-516			CK73FB1H103K	CHIP C	0.010UF	K
C517			CC45FCH1H220JM	CERAMIC	22PF	J
C518			CC73FCH1H220J	CHIP C	22PF	J
C524			CK73EB1H103K	CHIP C	0.010UF	K
C526			CC73FSL1H220J	CHIP C	22PF	J
C528,529			CC73FCH1H101J	CHIP C	100PF	J
C531			CK73FB1H103K	CHIP C	0.010UF	K
C532			CK73FB1H103K	CHIP C	0.010UF	K
C533,534			CK73FB1H472K	CHIP C	4700PF	K
C535			CK73FB1H223K	CHIP C	0.022UF	K
C701			CK73FB1H103K	CHIP C	0.010UF	K
C702			C90-3240-05	ELECTRO	2.2UF	35WV
C703			C91-0751-05	CERAMIC	330PF	K
C704			CK73FB1H561K	CHIP C	560PF	K
C705			CC73FCH1H470J	CHIP C	47PF	J
C706			CC73FCH1H220J	CHIP C	22PF	J
C707,708			CK73FB1H103K	CHIP C	0.010UF	K
C709			C90-3212-05	ELECTRO	47UF	6.3WV
CN1 ,2			E40-4871-05	PIN ASSY		
CN3			E40-4809-05	PIN ASSY		
CN4			E40-4810-05	SOCKET FOR PIN ASSY		
CN5			E40-4940-05	FLAT CABLE CONNECTOR		
CN6			E40-4902-05	FLAT CABLE CONNECTOR		
CN7			E40-4906-05	FLAT CABLE CONNECTOR		
CN8			E40-8161-05	SOCKET FOR PIN ASSY		
CN9			E40-8160-05	PIN ASSY		
CN10			E40-8169-05	SOCKET FOR PIN ASSY		
CN11			E40-8164-05	PIN ASSY		
CN12			E40-4632-05	PIN ASSY		
CN15			E40-4906-05	FLAT CABLE CONNECTOR		
J1			E63-1014-05	PHONO JACK		
J2			E63-0136-15	PHONO JACK		
J3			E63-0047-15	PHONO JACK		
J4			E08-0312-05	RECTANGULAR RECEPTACLE		
J5			E70-0034-05	LOCK TERMINAL BOARD		

L : Scandinavia K : USA P : Canada R : Mexico C : China I : Malaysia
 Y : PX(Far East, Hawaii) T : England E : Europe G : Germany V : China (Shanghai)
 Y : AAFES(Europe) X : Australia Q : Russia H : Korea M : Other Areas Δ indicates safety critical components.

* New Parts
 Parts without **Parts No.** are not supplied.
 Les articles non mentionnés dans le **Parts No.** ne sont pas fournis.
 Teile ohne **Parts No.** werden nicht geliefert.



Ref. No	Add-ress	New Parts	Parts No.	Description	Desti-nation	Re-marks
J501			E11-0300-05	PHONE JACK		
Δ F1			F05-4016-05	FUSE (SEMKO) (250V T400MAL)	TE	
Δ F1			F05-8013-05	FUSE (SEMKO) (250V T800MAL)	M	
CN13,14			J13-0075-05	FUSE CLIP		
L701			L40-1091-17	SMALL FIXED INDUCTOR(1UH)	TE	
L702			L40-1001-17	SMALL FIXED INDUCTOR(10UH,K) T1E1		
X501			L78-0267-05	RESONATOR (4.194MHZ)		
X502			L77-2173-05	CRYSTAL RESONATOR(32.768KHZ)	TE	
X701			L77-2002-05	CRYSTAL RESONATOR(4.332MHZ)		
R1 ,2			RK73FB2A102J	CHIP R 1.0K J 1/10W		
R3 ,4			RK73FB2A683J	CHIP R 68K J 1/10W		
R5 ,6			RK73FB2A102J	CHIP R 1.0K J 1/10W		
R7 ,8			RK73FB2A103J	CHIP R 10K J 1/10W		
R9 ,10			RK73FB2A102J	CHIP R 1.0K J 1/10W		
R11 ,12			RK73FB2A683J	CHIP R 68K J 1/10W		
R13 ,14			RK73FB2A102J	CHIP R 1.0K J 1/10W		
R15 ,16			RK73FB2A224J	CHIP R 220K J 1/10W		
R17 ,18			RK73FB2A102J	CHIP R 1.0K J 1/10W		
R19 ,20			RK73FB2A683J	CHIP R 68K J 1/10W		
R21 ,22			RK73FB2A102J	CHIP R 1.0K J 1/10W		
R23 ,24			RK73FB2A224J	CHIP R 220K J 1/10W		
R25 ,26			RK73FB2A331J	CHIP R 330 J 1/10W		
R27 -30			RK73FB2A224J	CHIP R 220K J 1/10W		
R35 ,36			RK73FB2A104J	CHIP R 100K J 1/10W		
R37 ,38			RK73FB2A202J	CHIP R 2.0K J 1/10W		
R39			RK73FB2A222J	CHIP R 2.2K J 1/10W		
R41			RK73FB2A102J	CHIP R 1.0K J 1/10W		
R43 ,44			RK73FB2A222J	CHIP R 2.2K J 1/10W		
R45 ,46			RK73FB2A224J	CHIP R 220K J 1/10W		
R47 ,48			RK73FB2A333J	CHIP R 33K J 1/10W		
R49 ,50			RK73FB2A101J	CHIP R 100 J 1/10W	M	
R49 ,50			RK73FB2A102J	CHIP R 1.0K J 1/10W		
R52 ,53			RK73FB2A102J	CHIP R 1.0K J 1/10W		
R67 ,68			RK73FB2A242J	CHIP R 2.4K J 1/10W		
R69 -72			RD14NB2E220J	RD 22 J 1/4W		
R73 -76			RS14KB3DR22J	FL-PROOF RS 0.22 J 2W		
R77 ,78			RK73FB2A622J	CHIP R 6.2K J 1/10W		
R79 ,80			RK73FB2A272J	CHIP R 2.7K J 1/10W		
R81			RK73FB2A471J	CHIP R 470 J 1/10W		
R85 ,86			RD14NB2E4R7J	RD 4.7 J 1/4W		
R89 ,90			RS14KB3D331J	FL-PROOF RS 330 J 2W		
R97 ,98			RK73FB2A332J	CHIP R 3.3K J 1/10W		
R99 ,100			RK73FB2A912J	CHIP R 9.1K J 1/10W		
Δ R101			RD14NB2E2R2J	RD 2.2 J 1/4W		
R102			RK73FB2A223J	CHIP R 22K J 1/10W		
R103			RK73FB2A102J	CHIP R 1.0K J 1/10W		
R104			RD14NB2E151J	RD 150 J 1/4W		
Δ R106			RD14NB2E100J	RD 10 J 1/4W		
R111			RK73FB2A163J	CHIP R 16K J 1/10W		
R112			RK73FB2A153J	CHIP R 15K J 1/10W		
Δ R113			RD14GB2E2R2J	FL-PROOF RD 2.2 J 1/4W		
R114			RK73FB2A473J	CHIP R 47K J 1/10W		
R115			RK73FB2A472J	CHIP R 4.7K J 1/10W		

L : Scandinavia K : USA P : Canada R : Mexico C : China I : Malaysia
 Y : PX(Far East, Hawaii) T : England E : Europe G : Germany V : China (Shanghai)
 Y : AAFES(Europe) X : Australia Q : Russia H : Korea M : Other Areas Δ indicates safety critical components.

* New Parts
 Parts without **Parts No.** are not supplied.
 Les articles non mentionnés dans le **Parts No.** ne sont pas fournis.
 Teile ohne **Parts No.** werden nicht geliefert.



Ref. No	Add-ress	New Parts	Parts No.	Description	Desti-nation	Re-marks
R116			RK73FB2A473J	CHIP R 47K J 1/10W		
R117			RK73FB2A472J	CHIP R 4.7K J 1/10W		
R118			RK73FB2A122J	CHIP R 1.2K J 1/10W		
Δ R119			RD14NB2E6R8J	RD 6.8 J 1/4W		
R121			RD14NB2E222J	RD 2.2K J 1/4W		
R122			RD14NB2E182J	RD 1.8K J 1/4W		
R124 ,125			RK73FB2A221J	CHIP R 220 J 1/10W		
R127			RK73FB2A104J	CHIP R 100K J 1/10W		
R133			RK73FB2A104J	CHIP R 100K J 1/10W		
R138			RK73FB2A473J	CHIP R 47K J 1/10W		
R139 ,140			RK73FB2A222J	CHIP R 2.2K J 1/10W		
Δ R141 ,142			RD14NB2E2R2J	RD 2.2 J 1/4W		
R149			RK73FB2A473J	CHIP R 47K J 1/10W		
Δ R155			RD14NB2E2R2J	RD 2.2 J 1/4W		
R157			RK73FB2A473J	CHIP R 47K J 1/10W		
R158			RK73FB2A103J	CHIP R 10K J 1/10W		
R159			RK73EB2B104J	CHIP R 100K J 1/8W	M	
R161			RK73FB2A332J	CHIP R 3.3K J 1/10W		
R162			RK73FB2A333J	CHIP R 33K J 1/10W		
R163			RK73FB2A222J	CHIP R 2.2K J 1/10W		
R166			RK73FB2A153J	CHIP R 15K J 1/10W		
R167			RK73FB2A682J	CHIP R 6.8K J 1/10W		
R170			RK73FB2A103J	CHIP R 10K J 1/10W		
R171			RK73FB2A222J	CHIP R 2.2K J 1/10W		
R173			RK73FB2A472J	CHIP R 4.7K J 1/10W		
R177			RK73FB2A104J	CHIP R 100K J 1/10W		
R185 ,186			RK73FB2A751J	CHIP R 750 J 1/10W		
R187 ,188			RK73FB2A471J	CHIP R 470 J 1/10W		
R191			RK73FB2A222J	CHIP R 2.2K J 1/10W		
R193			RK73FB2A223J	CHIP R 22K J 1/10W		
R509-511			RK73FB2A101J	CHIP R 100 J 1/10W		
R513-515			RK73FB2A101J	CHIP R 100 J 1/10W		
R517 ,518			RK73FB2A101J	CHIP R 100 J 1/10W		
R529 ,530			RK73FB2A103J	CHIP R 10K J 1/10W		
R531 ,532			RK73FB2A221J	CHIP R 220 J 1/10W		
R533-535			RK73FB2A103J	CHIP R 10K J 1/10W		
R536			RK73FB2A104J	CHIP R 100K J 1/10W		
R537			RK73FB2A102J	CHIP R 1.0K J 1/10W		
R538			RK73FB2A103J	CHIP R 10K J 1/10W		
R540 ,541			RK73FB2A331J	CHIP R 330 J 1/10W		
R542 ,543			RK73FB2A104J	CHIP R 100K J 1/10W		
R548 ,549			RK73FB2A103J	CHIP R 10K J 1/10W		
R551 ,552			RK73FB2A101J	CHIP R 100 J 1/10W	TE	
R553 ,554			RK73FB2A104J	CHIP R 100K J 1/10W		
R555 ,556			RK73FB2A472J	CHIP R 4.7K J 1/10W		
R557			RK73FB2A103J	CHIP R 10K J 1/10W		
R561			RK73FB2A104J	CHIP R 100K J 1/10W		
R564			RK73FB2A514J	CHIP R 510K J 1/10W		
R569			RK73FB2A103J	CHIP R 10K J 1/10W		
R580 ,581			RK73FB2A104J	CHIP R 100K J 1/10W	TE	
R582 ,583			RK73FB2A103J	CHIP R 10K J 1/10W		
R584			RK73FB2A104J	CHIP R 100K J 1/10W		
R585			RK73FB2A103J	CHIP R 10K J 1/10W		
R586 ,587			RK73FB2A222J	CHIP R 2.2K J 1/10W		
R589			RK73FB2A473J	CHIP R 47K J 1/10W		

L : Scandinavia K : USA P : Canada R : Mexico C : China I : Malaysia
 Y : PX(Far East, Hawaii) T : England E : Europe G : Germany V : China (Shanghai)
 Y : AAFES(Europe) X : Australia Q : Russia H : Korea M : Other Areas Δ indicates safety critical components.

PARTS LIST

R-SG7/SG7G

* New Parts
 Parts without **Parts No.** are not supplied.
 Les articles non mentionnés dans le **Parts No.** ne sont pas fournis.
 Teile ohne **Parts No.** werden nicht geliefert.

11

Ref. No	Add-ress	New Parts	Parts No.	Description	Desti-nation	Re-marks
R591			RK73FB2A104J	CHIP R 100K J 1/10W	TE	
R592,593			RK73FB2A103J	CHIP R 10K J 1/10W		
R704			RK73FB2A222J	CHIP R 2.2K J 1/10W		
VR1 ,2			R12-1616-05	TRIMMING POT.(1K)		
W203-205			R92-0679-05	CHIP R 0 OHM		
W206			R92-0670-05	CHIP R 0 OHM		
W207-209			R92-0679-05	CHIP R 0 OHM		
W211			R92-0670-05	CHIP R 0 OHM		
W212			R92-0679-05	CHIP R 0 OHM		
W215,216			R92-0670-05	CHIP R 0 OHM		
W218-221			R92-0679-05	CHIP R 0 OHM	TE M	
W501-506			R92-0679-05	CHIP R 0 OHM		
W501,502			R92-0679-05	CHIP R 0 OHM		
W508-512			R92-0679-05	CHIP R 0 OHM		
W901			R92-0670-05	CHIP R 0 OHM		
Δ K1 ,2			S76-0075-15	MAGNETIC RELAY		
K3			S76-0056-05	MAGNETIC RELAY		
S501-509			S70-0031-05	TACT SWITCH		
PH1 -4			T95-0149-05	OPTO ISOLATOR		
S516			T99-0598-05	ROTARY ENCODER		
Δ D5			D3SBA20F03	DIODE		
Δ D5			RBV-402LFA	DIODE		
Δ D6 ,7			MA111	DIODE		
Δ D8 ,9			HSS104A	DIODE		
Δ D8 ,9			1SS131	DIODE		
Δ D10 -14			S5688B	DIODE		
Δ D10 -14			1SR139-400	DIODE		
D15 ,16			HZS16N(B2)	ZENER DIODE		
D15 ,16			MTZJ16(B)	ZENER DIODE		
D17			HZS6.2N(B2)	ZENER DIODE		
D17			MTZJ6.2(B)	ZENER DIODE		
D18			HZS6.8N(B2)	ZENER DIODE		
D18			MTZJ6.8(B)	ZENER DIODE		
D19			HZS6.2N(B2)	ZENER DIODE		
D19			MTZJ6.2(B)	ZENER DIODE		
D20 ,21			HZS4.7N(B2)	ZENER DIODE		
D20 ,21			MTZJ4.7(B)	ZENER DIODE		
D22			HZS5.1N(B2)	ZENER DIODE		
D22			MTZJ5.1(B)	ZENER DIODE		
D23			HZS3.9N(B2)	ZENER DIODE		
D23			MTZJ3.9(B)	ZENER DIODE		
D24			HZS4.7N(B2)	ZENER DIODE		
D24			MTZJ4.7(B)	ZENER DIODE		
D25 ,26			HSS104	DIODE		
D25 ,26			1SS133	DIODE		
D27			HZS11N(B2)	ZENER DIODE		
D27			MTZJ11(B)	ZENER DIODE		
D28			HZS4.7N(B2)	ZENER DIODE		
D28			MTZJ4.7(B)	ZENER DIODE		
D29 ,30			HSS104	DIODE		
D29 ,30			1SS133	DIODE		
D31			MA111	DIODE		
D32			HSS104	DIODE		
D32			1SS133	DIODE		

L : Scandinavia K : USA P : Canada R : Mexico C : China I : Malaysia
 Y : PX(Far East, Hawaii) T : England E : Europe G : Germany V : China (Shanghai)
 Y : AAFES(Europe) X : Australia Q : Russia H : Korea M : Other Areas Δ indicates safety critical components.

* New Parts
 Parts without **Parts No.** are not supplied.
 Les articles non mentionnés dans le **Parts No.** ne sont pas fournis.
 Teile ohne **Parts No.** werden nicht geliefert.

12

Ref. No	Add-ress	New Parts	Parts No.	Description	Desti-nation	Re-marks
D33			HZS4.7N(B2)	ZENER DIODE		
D33			MTZJ4.7(B)	ZENER DIODE		
D36 ,37			HZS20N(B)	ZENER DIODE		
D36 ,37			MTZJ20	ZENER DIODE		
D39			HZS3.9N(B2)	ZENER DIODE		
Δ D39			MTZJ3.9(B)	ZENER DIODE		
D40			KBP02ML-6127	DIODE		
D502			MA111	DIODE		
D503			HSS104	DIODE		
D503			1SS133	DIODE		
D504-511			MA111	DIODE	TE TE	
D512			HSS104	DIODE		
D512			1SS133	DIODE		
D513,514			MA111	DIODE		
D515-517			HSS104A	DIODE		
D515-517			1SS131	DIODE		
D518			HSS104	DIODE	M M TE TE	
D518			1SS133	DIODE		
D519			HSS104A	DIODE		
D519			1SS131	DIODE		
D521,522			HSS104	DIODE		
D521,522			1SS133	DIODE		
D523			MA111	DIODE		
D531			MA111	DIODE		
D532			HSS104	DIODE		
D532			1SS133	DIODE		
D701			HSS104	DIODE	TE TE	
D701			1SS133	DIODE		
ED1			FIP9GM6R	INDICATOR TUBE		
ED1		*	HNA-09SS18	INDICATOR TUBE		
IC1			NJU7313AM	ANALOGUE IC		
IC2			NJM4565D-D	IC(OP AMP X2)		
IC3		*	M62421SP	ANALOGUE IC		
IC4			M5219P	ANALOGUE IC		
IC5			NJM4565L-D	ANALOGUE IC		
IC11		*	UPD78045FGF088	MI-COM IC		
IC12			S-806D-Z	ANALOGUE IC		
IC13			X24C04S	MEMORY IC	TE TE	
IC701			SAA6579	ANALOGUE IC		
Q1 -4			2SC4213(B)	TRANSISTOR		
Δ Q5 ,6			2SD2589K	TRANSISTOR		
Δ Q7 ,8			2SB1659K	TRANSISTOR		
Q9 ,10			2SC4137(V,W)	TRANSISTOR		
Δ Q11 ,12			2SC1845(F,E)	TRANSISTOR		
Q15 ,16			2SC4213(B)	TRANSISTOR		
Δ Q51			2SD2589K*2	TRANSISTOR		
Q52			2SC1845(F,E)	TRANSISTOR		
Q53			DTC113ZUA	DIGITAL TRANSISTOR		
Q53			UN5219	DIGITAL TRANSISTOR		
Q54			2SA992(F,E)	TRANSISTOR		
Δ Q55			2SA1534A(R,S)	TRANSISTOR		
Q56 ,57			2SC4081(R,S)	TRANSISTOR		
Q56 ,57			2SD1819A(Q,R)	TRANSISTOR		
Δ Q58			2SB764(E,F)	TRANSISTOR		
Δ Q59			2SD2525	TRANSISTOR		

L : Scandinavia K : USA P : Canada R : Mexico C : China I : Malaysia
 Y : PX(Far East, Hawaii) T : England E : Europe G : Germany V : China (Shanghai)
 Y : AAFES(Europe) X : Australia Q : Russia H : Korea M : Other Areas Δ indicates safety critical components.

* New Parts
 Parts without **Parts No.** are not supplied.
 Les articles non mentionnés dans le **Parts No.** ne sont pas fournis.
 Teile ohne **Parts No.** werden nicht geliefert.



Ref. No	Add- ress	New Parts	Parts No.	Description	Desti- nation	Re- marks
Q60 ,61			2SA1576A(R,S)	TRANSISTOR		
Q60 ,61			2SB1218A(Q,R)	TRANSISTOR		
Δ Q62			2SC2003(L,K)	TRANSISTOR		
Q63			2SC4081(R,S)	TRANSISTOR		
Q63			2SD1819A(Q,R)	TRANSISTOR		
Q64 -66			2SC1845(F,E)	TRANSISTOR		
Q67			2SA992(F,E)	TRANSISTOR		
Q68			2SA1576A(R,S)	TRANSISTOR		
Q68			2SB1218A(Q,R)	TRANSISTOR		
Q69 ,70			2SC4081(R,S)	TRANSISTOR		
Q69 ,70			2SD1819A(Q,R)	TRANSISTOR		
Δ Q71			2SA954(L,K)	TRANSISTOR		
Q504			2SC4081(R,S)	TRANSISTOR		
Q504			2SD1819A(Q,R)	TRANSISTOR		
A1			W02-2561-05	ELECTRIC CIRCUIT MODULE		

PARTS LIST

R-SG7/SG7G

L : Scandinavia K : USA P : Canada R : Mexico C : China I : Malaysia
 Y : PX(Far East, Hawaii) T : England E : Europe G : Germany V : China (Shanghai)
 Y : AAFES(Europe) X : Australia Q : Russia H : Korea M : Other Areas Δ indicates safety critical components.

R-SG7/SG7G

SPECIFICATIONS

Receiver (R-SG7)

[Amplifier section]

Rated power output

Class AB operation

20 watts per channel minimum RMS, both channels driven, at 6 Ω , 1 kHz with no more than 10 % total harmonic distortion.

(DIN) 1 kHz at 6 Ω , 0.7 % T.H.D. 15 W + 15 W

Class A operation

7.5 watts per channel minimum RMS, both channels driven, at 6 Ω , 1 kHz with no more than 10 % total harmonic distortion.

Total harmonic distortion 0.02% (1 kHz, 10 W, 6 Ω)

Frequency response 20 Hz ~ 40 kHz, +0 dB, -3 dB

Input sensitivity / Impedance 200 mV / 47 k Ω

Output level / Impedance

SUPER WOOFER PRE OUT 2.0 V / 1 k Ω

TAPE REC 200 mV / 1 k Ω

Signal to noise ratio 96 dB (IHF'66)

[FM Tuner section]

Tuning frequency range 87.5 MHz ~ 108 MHz

Usable sensitivity (DIN)

MONO ... 1.2 μ V (75 Ω) / 13.2 dBf (40 kHz DEV., S/N 26 dB)

Signal to noise ratio

(DIN weighted at 1 kHz, 65.2 dBf input)

MONO 65 dB

STEREO 58 dB

Selectivity (DIN \pm 300 kHz) 64 dB

Stereo separation (DIN at 1 kHz) 35 dB

[AM Tuner section]

Tuning frequency range 531 kHz ~ 1,602 kHz

Usable sensitivity (30% mod., S/N 20 dB)

..... 15 μ V / (500 μ V/m)

Signal to noise ratio (at 30% mod., 1 mV input)

..... 48 dB

Output level / Impedance (30% mod., 1 mV input)

..... 0.18 V / 1 k Ω

General

Power consumption 45 W

Dimensions W: 200 mm

H: 77 mm

D: 278 mm

Weight (net) 3.0 kg

CD player (DP-SG7)

Laser Semiconductor laser

Playing rotation 200 rpm ~ 500 rpm (CLV)

Frequency response 4 Hz ~ 20 kHz, \pm 1.0 dB

Signal to noise ratio More than 100 dB

Dynamic range More than 96 dB

Total harmonic distortion

..... Less than 0.004 % (at 1 kHz)

Channel separation More than 92 dB (at 1 kHz)

Wow & Flutter Unmeasurable Limit

Output level / Impedance

Fixed 1.2 V / 1 k Ω

Digital output

Optical -15 dBm ~ -21 dBm
(wave length 660 nm)

General

Power consumption 10 W

Dimensions W: 200 mm

H: 77 mm

D: 249 mm

Weight (net) 2.0 kg

Cassette deck (X-SG7)

Track 4-track, 2-channel stereo

Recording system AC bias system
(Frequency: 105 kHz)

Heads

Playback / recording head 1

Erasing head 1

Motors 1

Wow and flutter 0.1 % (W.R.M.S.)

Fast winding time Approx. 110 seconds
(C-60 tape)

Frequency response

TYPE I tape 40 Hz to 18,000 Hz, \pm 3 dB

TYPE IV tape 40 Hz to 19,000 Hz, \pm 3 dB

Signal to noise ratio

Dolby B NR ON 67 dB (CrO2 tape)

Dolby C NR ON 73 dB (CrO2 tape)

Dolby NR OFF 60 dB (CrO2 tape)

Input sensitivity / Impedance 77.5 mV / 47 k Ω

Output level / Impedance 775 mV / 10 k Ω

General

Power consumption 14 W

Dimensions W: 200 mm

H: 77 mm

D: 249 mm

Weight (net) 2.2 kg



- 1.KENWOOD follows a policy of continuous advancements in development. For this reason specifications may be changed without notice.
- 2.Sufficient performance may not be possible at very low temperatures (under a water-freezing temperature).

Note:

Component and circuit are subject to modification to insure best operation under differing local conditions. This manual is based on Europe (E) standard, and provides information on regional circuit modification through use of alternate schematic diagrams, and information on regional component variations through use of parts list.

KENWOOD CORPORATION

14-6,Dogenzaka 1-chome, Shibuya-ku, Tokyo, 150-8501 Japan

KENWOOD SERVICE CORPORATION

P.O BOX 22745, 2201 East Dominguez St., Long Beach, CA 90801-5745, U.S.A.