

MINI HiFi COMPONENT SYSTEM
**RXD-251/301/301E/301W/
 351/351E/351W/371S/A3**
SERVICE MANUAL
 (XD-251~A3)**

KENWOOD

© 1998-7/B51-5454-00 (K/K) 3763

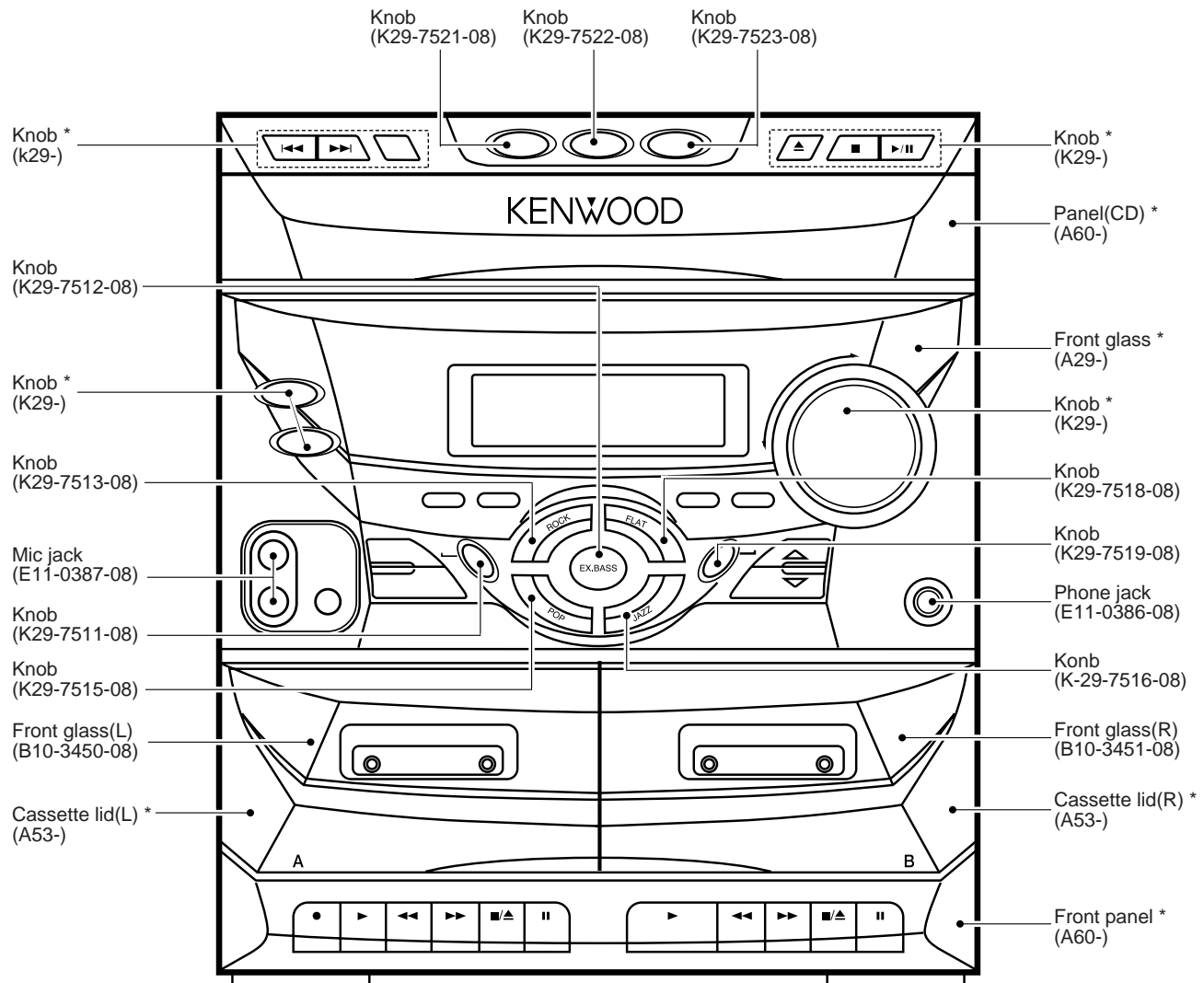

Illust. is RXD-351.

*** Refer to parts list on page 38.**

****Refer to page 2 if you want to know system configuration.**

In compliance with Federal Regulations, following are reproductions of labels on, or inside the product relating to laser product safety.

KENWOOD-Crop. certifies this equipment conforms to DHHS Regulations No. 21 DFR 1040. 10, Chapter 1, Subchapter J.

DANGER : Laser radiation when open and interlock defeated. AVOID DIRECT EXPOSURE TO BEAM

RXD-251/301/351/371S/A3

CONTENTS / ACCESSORIES

Contents

CONTENTS / ACCESSORIES	2	WIRING DIAGRAM	15
EXTERNAL VIEW	3	PARTS DESCRIPTIONS	16
CONTROLS	4	PC BOARD	17
BLOCK DIAGRAM	6	SCHEMATIC DIAGRAM	23
CIRCUIT DESCRIPTION	7	EXPLODED VIEW	37
CD MECHANISM OPERATION DESCRIPTION	9	PARTS LIST	38
ADJUSTMENT	11	SPECIFICATIONS	47

Accessories

FM indoor antenna (1)

Europe and U.K.
(T90-0836-05)
: E1E2E3E4T1T2Q1Q2

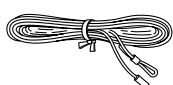

Other countries
(T90-0801-05)
: K1P1Y1M1M2M3X1X2X3

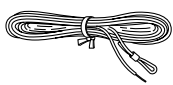

AC plug adaptor (1)
(E03-0115-05)

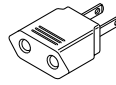

Use to adapt the plug on the power cord to the shape of the wall outlet.
(Accessory only for regions where use is necessary.)

Batteries (R6/AA) (2)

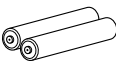

AM loop antenna (1)
(T90-0815-08)

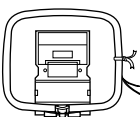

Remote control unit (1)
(A70-1260-08)

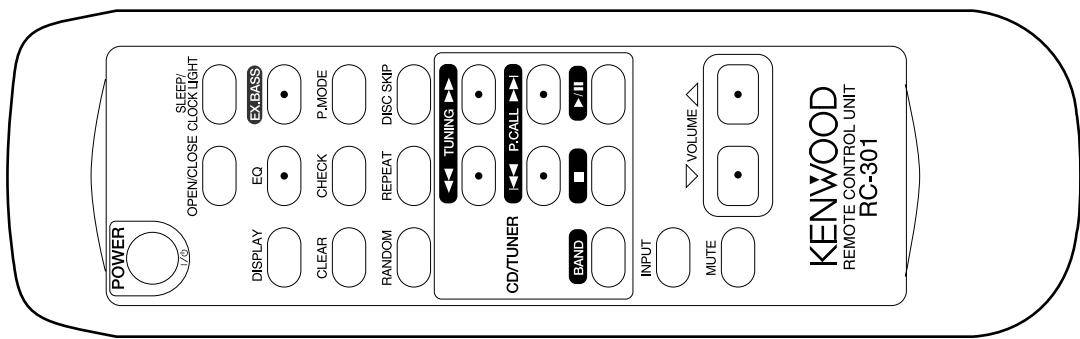

System configuration

SYSTEM	MAIN UNIT	DESTINATION	SPEAKER
XD-301	RXD-301	E3T2X3	LS-N301
XD-301E	RXD-301E	E4	LS-N301
XD-301W	RXD-301W	Q2	LS-N301
XD-351	RXD-351	E1T1	LS-N351
XD-351	RXD-351	M1X1Y1	LS-N371
XD-351E	RXD-351E	E2	LS-N351
XD-351W	RXD-351W	Q1	LS-N351
XD-A3	RXD-A3	K1P1	LS-N351
XD-371S	RXD-371S	M2	LS-N371
XD-251	RXD-251	M3X2	LS-N351

Cautions

Operation to reset

The microcomputer may fall into malfunction (impossibility to operate, erroneous display, etc.) when the power cord is unplugged while power is ON or due to an external factor. In this case, execute the following procedure to reset the microcomputer and return it to normal condition.

Press the "POWER" key while holding the Stop (■) key of the CD section pressed, to switch off the power, and then switch the power on again after a few seconds.

- Please note that resetting the microcomputer clears the contents stored in and returns and to condition when it left the factory.

RXD-251/301/351/371S/A3

EXTERNAL VIEW

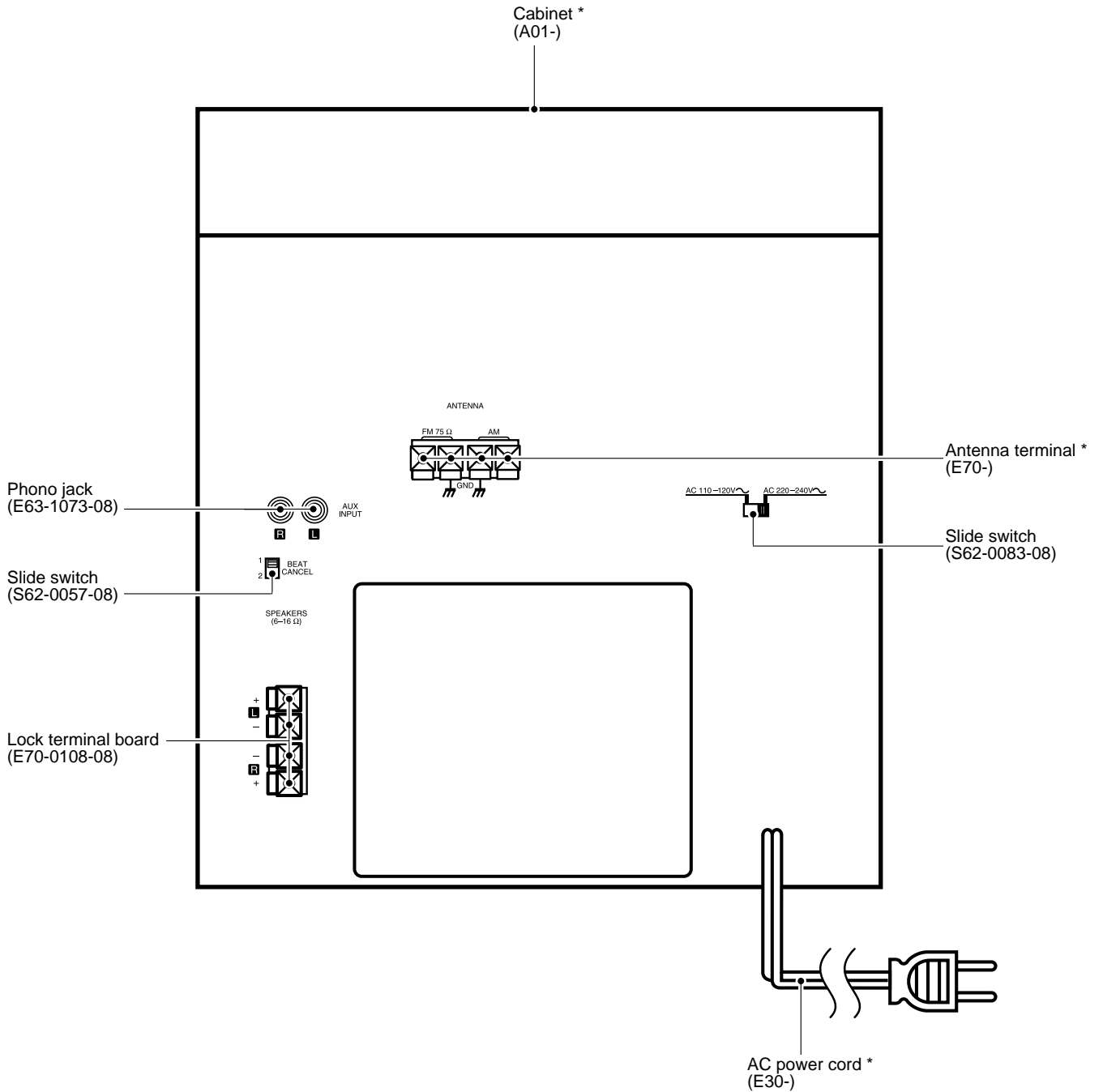

Illust. is RXD-351.

* Refer to parts list on page 38.

CONTROLS

CD unit

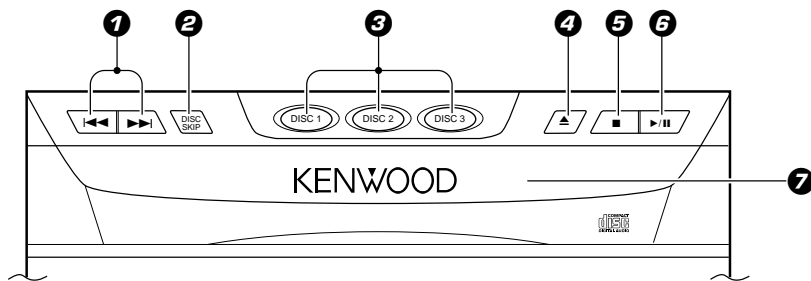

1 Skip (◀◀, ▶▶) keys

2 DISC SKIP key

Used to skip discs.

3 Disc selection keys

The disc number is selected directly and playback starts.

4 OPEN/CLOSE (▲) key

The disc tray is opened and closed.

5 Stop (■) key

6 Play/pause (▶/⏸) key

7 Disc tray

Three discs can be stored.

Receiver unit

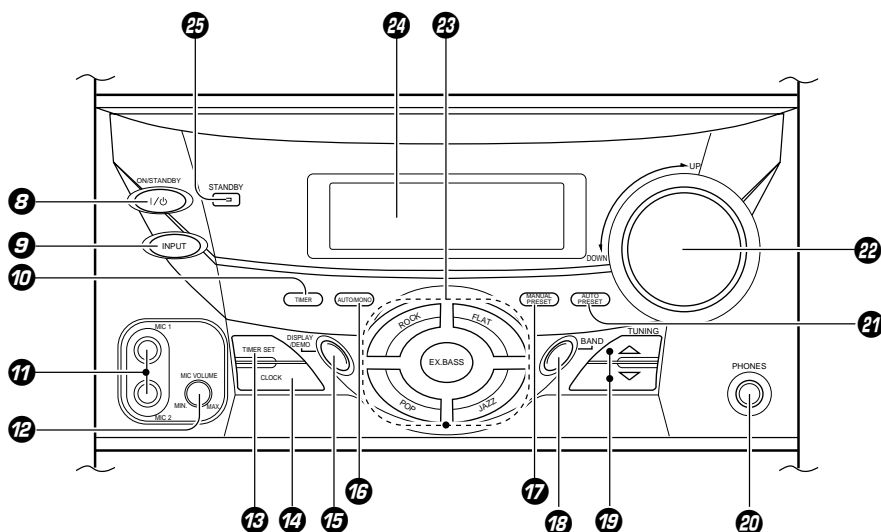

8 ON/STANDBY (I/O) key

9 INPUT key

Key for input switching.

10 TIMER key

Key for timer START/STOP switching.

11 MIC 1/MIC 2 jack (except for some areas)

12 MIC VOLUME knob (except for some areas)

13 TIMER SET key

Used for setting the timer ON/OFF time.

14 CLOCK key

Used to set the present time.

15 DISPLAY/DEMO key

Switches the display contents.

*Used for demonstration (DEMO) ON/OFF.

16 AUTO/MONO key

Switches the tuning mode.

17 MANUAL PRESET key

Used to memorize broadcasting stations in the desired order.

18 BAND key

Press to switch the receiving band.

19 TUNING/▲▼ keys

Used for tuning to broadcasting stations and for time settings.

20 PHONES terminal

For connection of a headphone (optional).

21 AUTO PRESET key

Used for automatic presetting of broadcasting stations.

22 VOLUME CONTROL knob

This is used for volume adjustment.

23 Sound selection keys

Used to select the desired sound type.

FLAT : For listening without changing the sound.

JAZZ : A sound quality curve suitable for jazz.

POP : A sound quality curve suitable for popular music.

ROCK : A sound quality curve suitable for rock-and-roll.

EX.BASS : For listening with abundant bass. (Can be used together with other sound selection keys.)

24 Display

25 STANDBY indicator (Except for some areas)

CONTROLS

Cassette deck unit

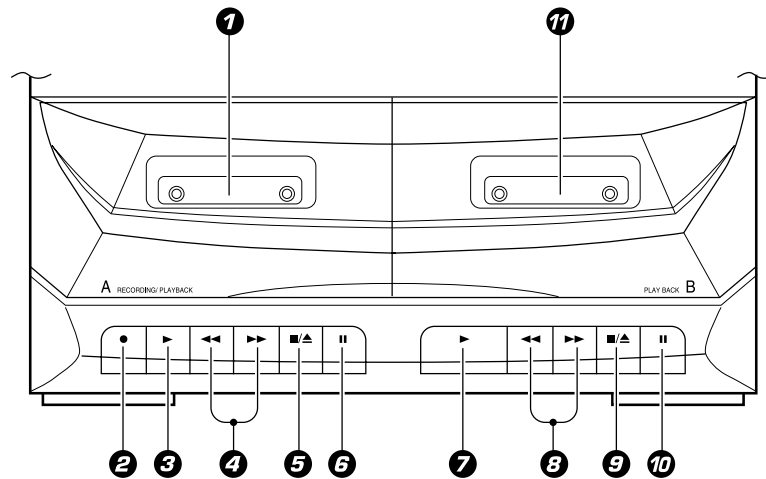

A deck

1 Cassette holder

Press the / key to remove and insert the tape.

2 REC (●)key

3 Play (▶) key

4 Fast forward and rewind (◀◀, ▶▶) keys

5 Stop/Eject (■/▲) key

6 Pause (||) key

B deck

7 Play (▶) key

8 Fast forward and rewind (◀◀, ▶▶) keys

9 Stop/Eject (■/▲) key

10 Pause (||) key

11 Cassette holder

Press the / key to remove and insert the tape.

Display

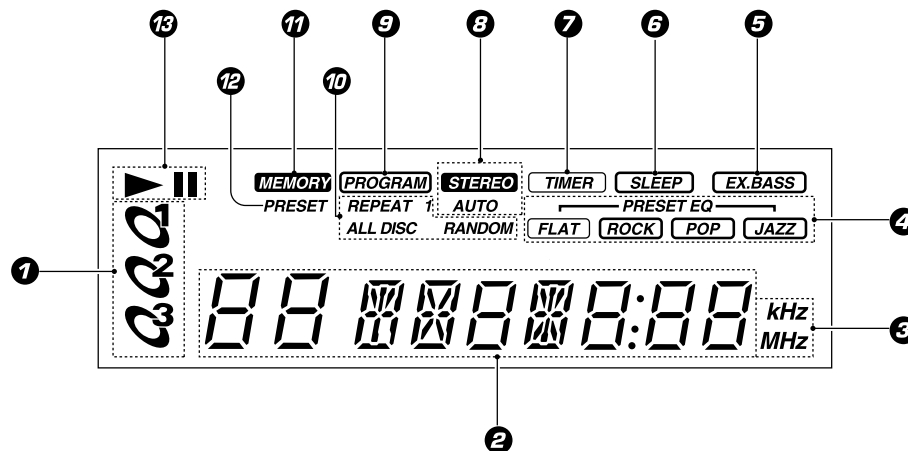

1 Disc display

When CD is selected, the numbers for which a disc has been set light.

2 Letter and number display

Title number, playback time, present time, etc. are displayed.

3 Reception frequency unit indication (kHz/MHz)

4 Sound selection indication

5 Extra bass (EX.BASS) indication

6 Sleep timer (SLEEP) indication

7 Timer (TIMER) indication

8 STEREO/AUTO indication

Indication of the reception mode for stereo broadcasts

9 PROGRAM indication

Lights at the time of program mode.

10 Repeat/Random mode indication

11 MEMORY indication

Shows when a broadcasting station is memorized.

12 PRESET indication

13 Playback (▶), Pause (||) indication

TUNER UNIT

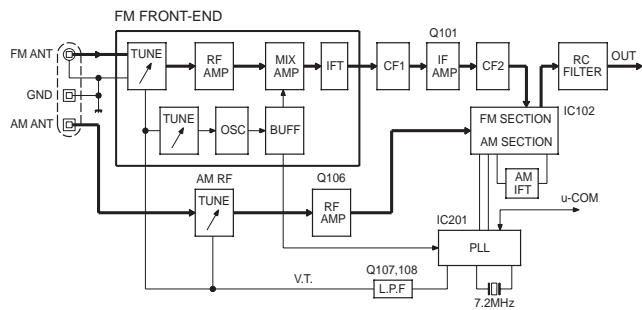

TUNER UNIT

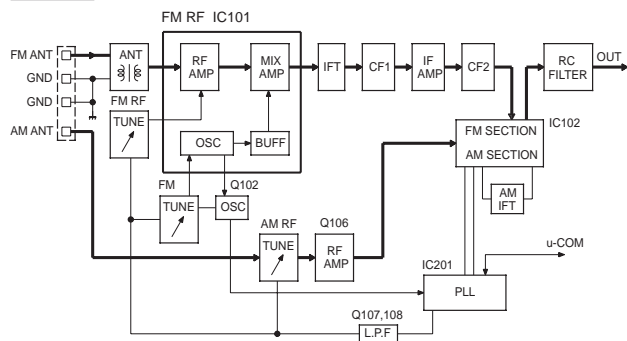

CD MECHA. UNIT

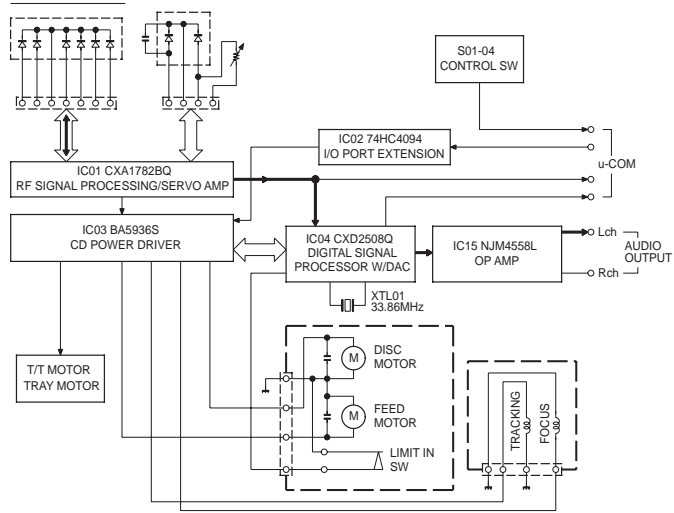

AUDIO UNIT/DISPLAY UNIT

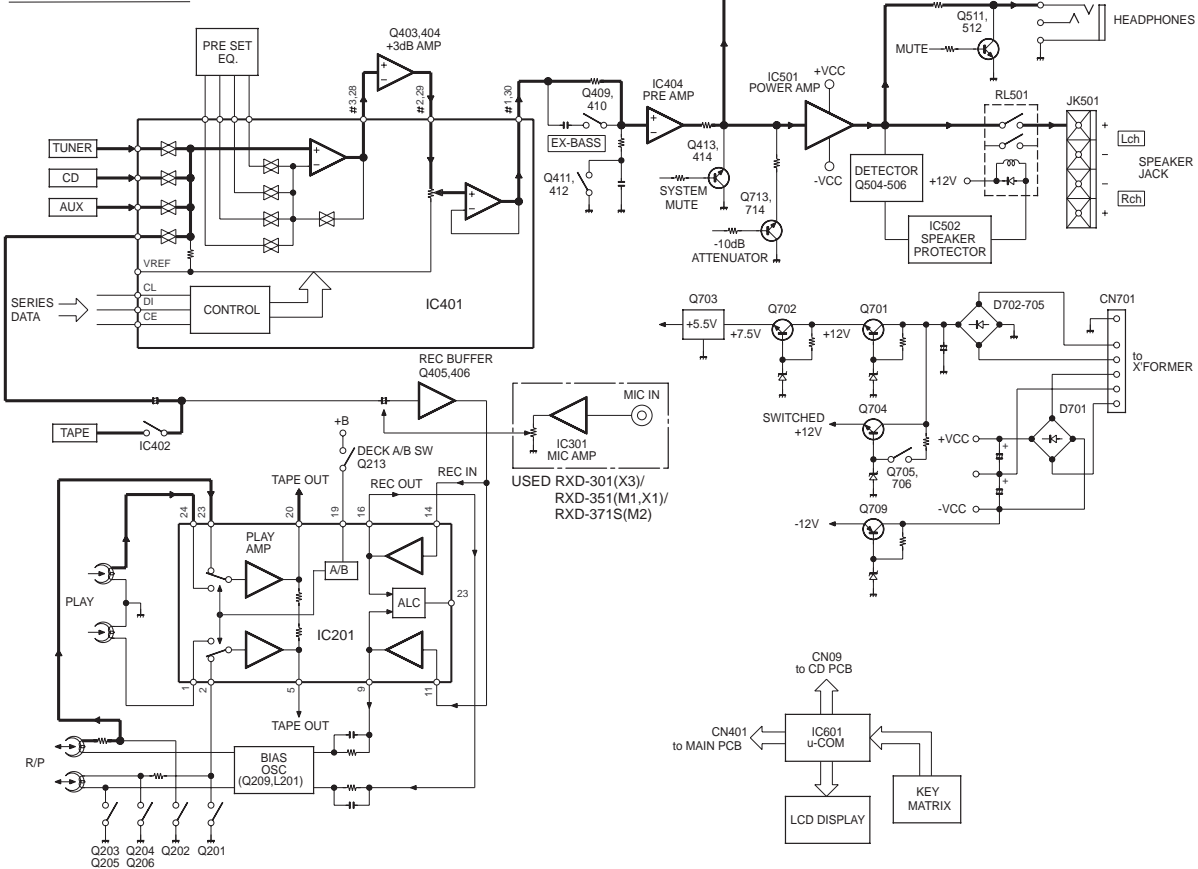

RXD-251/301/351/371S/A3

BLOCK DIAGRAM

CIRCUIT DESCRIPTION

1. Microprocessor : (IC601, LC867224A-5H71)

1-1 Pin description

No.	Name	I/O	Description	Active	
				H	L
1	CE	I	LC7218, LC75392 CE out		
2	ENABLE	-	No used		
3	DI	I	LC7218, LC75392, 74HC4094 data out		
4	DO	O	Data output to LC7218		
5	CLK	I	LC 7218, LC75392, 74HC4094 clock out		
6	DATA	O	Serial data out to CXD2508Q		
7	SQCO	I	Serial output of SUBQ 80BIT		
8	SQCK	O	Clock output		
9	XLAT	O	Latch output		
10	FOK	O	Focus OK output		
11	GND	-	GND		
12	RESET	I	Reset signal input		
13	POWER - DOWN	I	Power down input		
14	SENS	I	CXD2508Q sens		
15	VSS	-	Vss		
16	X1	-	Xtal 6.0MHz		
17	X2	-	Xtal 6.0MHz		
18	VDD1	-	Vdd		
19~22	K1~K4	I	Key input (K1~K4)		
23, 24	GND	-	GND		
25	MODE - SW2	I	Model discrimination (RXD-371S only)		
26	MODE - SW1	I	Model discrimination		
27	SCOR	I	CXD2508Q Sub - code synch detect		
28	COUNT	O	Track number count signal output		
29	REMOTE IN	I	Remote signal input		
30	VR +	I	VR encoder input A		
31	VR -	I	VR encoder input B		
32	PIC - UP	I	Pick - up SW		
33	PIC - DOWN	I	Pick - down SW		
34	DISC - COUNT	I	Disc counter SW		
35	TURNTABLE - SW	I	Turntable SW		
36	TRAY - OPEN	I	Tray open SW		
37	TRAY - CLOSE	I	Tray close SW		
38	N/C	-	No used		
39	VR - 1	O	VR step extend out	0, 1 step	others
40~51	N/C	-	No used		
52~55	S1 - S4	O	Segment out (1~4)		
56	VDD2	-	Vdd		
57	VSS2	-	Vss		
58~79	S5~S26	O	Segment out (5~26)		
80~82	BIAS 3~1	-	GND		
83~86	COM - 0~3	O	FL Common 0~3		
87	FM - STEREO	I	FM stereo signal input	Mono	Stereo
88	SYN REC	I	Synchro start input		
89	VSS3	-	Vss		

RXD-251/301/351/371S/A3

CIRCUIT DESCRIPTION

No.	Name	I/O	Description	Active	
				H	L
90	VDD3	–	Vdd		
91	POWER - SW	O	Power SW out	On	Off
92	SYS - MUT	O	System mute out	Off	On
93	TU - MUT	O	Tuner mute out	On	Off
94	MODE - SW - IN	I	No used		
95	FUNCTION - TAPE	O	Function tape out	Tape	Others
96	LCD - BACK - LIGHT	O	LCD back light control	On	Off
97	N/C	–	No used		
98	EX - BASS	O	EX - bass control	On	Off
99	LATCH	–	No used		
100	STB	O	74HC4094 strobe		

2. Key matrix

PORT	SW 1	SW 2	SW 3	SW 4	SW 5	SW 6	SW 7	SW 8	SW 9	SW 10
Pin 19 (K1)	Power	Input	Clock Set	Timer Mode	Timer Set	Display	EQ Off	Rock	Jazz	Pop
Pin 20 (K2)	Tuning Up	Tuning Down	Band	Auto/ Mono	Auto Preset	Manual Preset	EX Bass	–	–	–
Pin 21 (K3)	CD AMS +	AMS -	–	–	Disc Skip	Disc 1	Disc 2	Disc 3	Open Close	–
Pin 22 (K4)	CD Stop	CD Play Pause	FF	–	–	–	–	–	–	–

3. I/O port extension (CD mecha. unit)

IC02 (74HC4094)

PIN	NAME	I/O	DESCRIPTION	ACTIVE
4	MUTE	O	CXD2508Q Muting (DAC)	H : ON L : OFF
5	CONTROL	O	CXA1782BQ, CXD2508Q Vdd control	H : Others L : CD
6	XRST	O	CXD2508Q XRST	
7	T • T +	O	T • T/U • D Motor (+)	
11	CONTROL	O	T • T Motor speed Control	
12	TRAY -	O	Tray Motor Control (-)	
13	TRAY +	O	Tray Motor Control (+)	
14	T • T -	O	T • T/U • D Motor (-)	

4. All LCD light on mode

- The all LCD light up when the STOP key and TIMER SET key are pressed simultaneously, while the power is ON.
- When the ON/STANDBY key is pressed, the all LCD light on mode is canceled.

CD MECHANISM OPERATION DESCRIPTION

1. In case of disc 3 (Refer to figure 1 and 2)

- ① The rotary motor turns counterclockwise by pressing disc 3 key, therefore the turntable turns clockwise and disc 3 is detected by disc number detector switch.
- ② The turntable stops the position of ► marked as figure 2 and stop position of disc 3 is detected by sensor switch. At this time, the position of TR lock gear is as shown figure 1.
- ③ The rotary motor turns clockwise and the relay gear B also turns clockwise. By turning the relay gear B, the arm of relay gear B moves to arrow direction (◀ ■ ■ ■) and the TR lock gear will be locked. After that, the change gear separates from TR lock gear.
- ④ The UD reduce gear turns clockwise by turning the change gear.
- ⑤ The traverse moves up-side.
- ⑥ After finished the traverse operation, the disc motor turns and the disc 3 will be played.

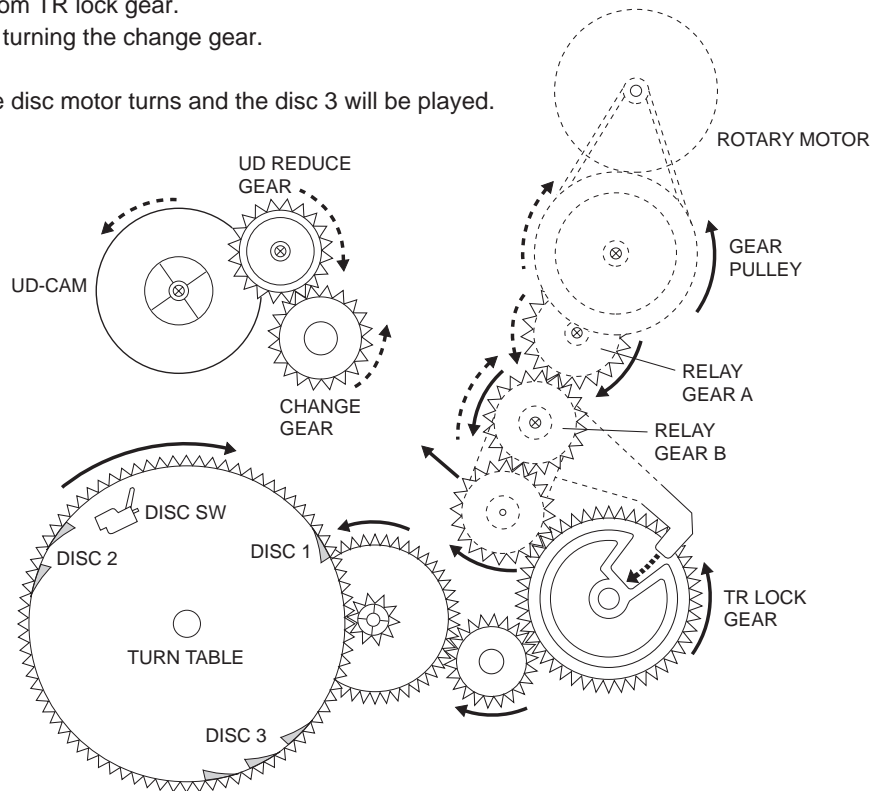

Fig.1

2. Open/Close operation of tray while playing the disc.

(Refer to figure 3)

- ① The tray motor turns clockwise by pressing open/close key while playing the disc.
- ② The change base moves to frontward by turning the TR gear.
- ③ Pushing switch C by change base, the tray motor stops.

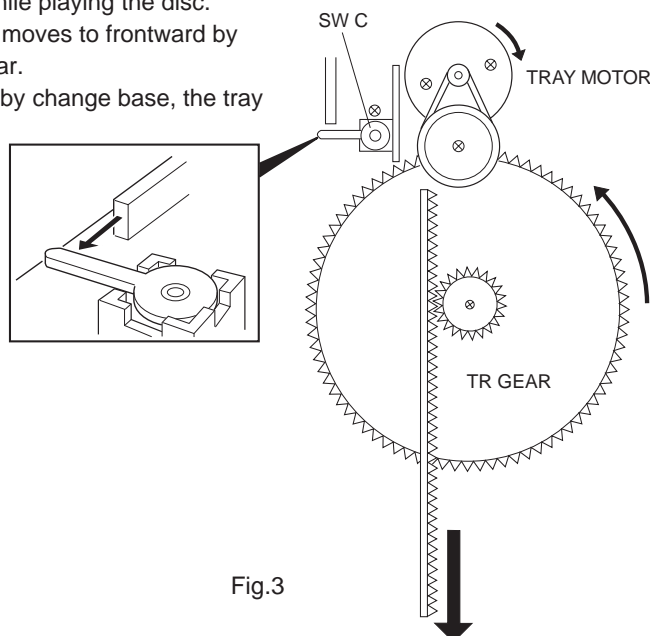

Fig.3

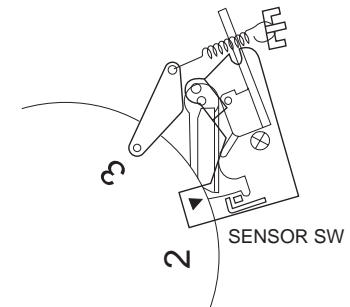

Fig.2
(STOP POSITION OF DISC 3)

RXD-251/301/351/371S/A3

CD MECHANISM OPERATION DESCRIPTION

※ How to replace the pick up. (Refer to figure 4~7)

1. Remove the screws (① x 4), top chassis and spring (② x 2).
2. Detach the traverse unit by removing shield (bottom side) and screws (③ x 2).
3. Short the short land and remove screws (④ x 4, ⑤ x 1).
4. Remove the rod and replace the pick up.

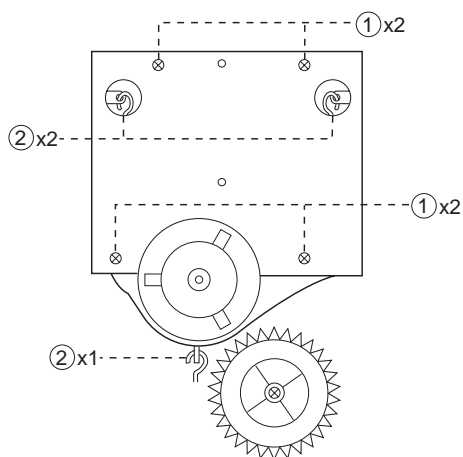

Fig.4

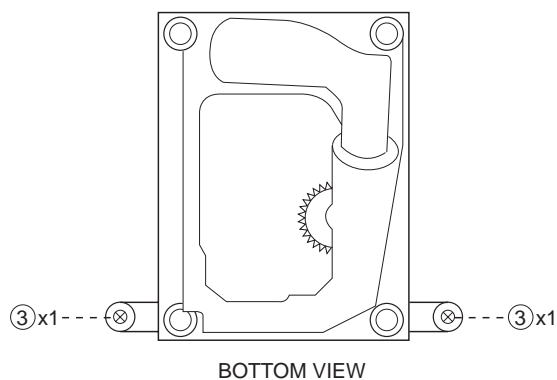

Fig.5

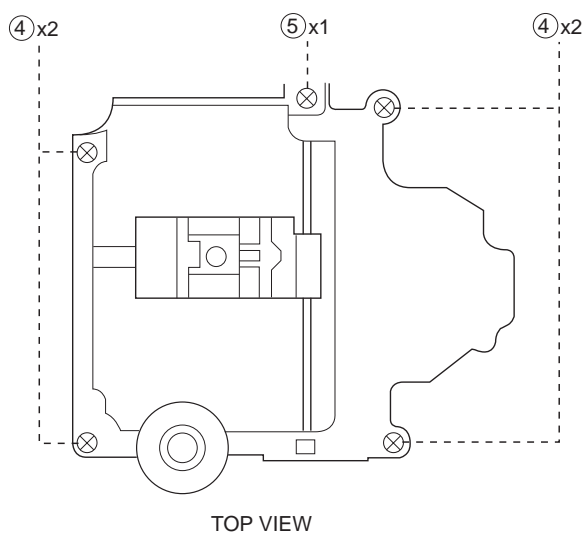

Fig.6

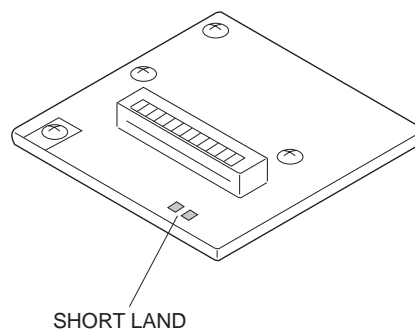

Fig.7

ADJUSTMENT

FM SECTION (Except for Europe version)

* Europe version no Adjustment

NO.	ITEM	INPUT SETTING	OUTPUT SETTING	TUNER SETTING	ALIGNMENT POINTS	ALIGN FOR	FIG.
1.	IF	(A) 98 MHz, 1 kHz MOD ±75 kHz (DEV) 60 dBu (ANT INPUT)	(B)	98MHz	T101	Maximum output (Minimum distortion)	
2.	LOWEND TRACKING	(A) 87MHz, 1 kHz MOD ±75 kHz (DEV) 35 dBu (ANT INPUT)	(B)	87MHz	L102	Maximum output	
3.	HIEND TRACKING	(A) 108MHz, 1 kHz MOD ±75 kHz (DEV) 35 dBu (ANT INPUT)	(B)	108MHz	TC101	Maximum output	
4.	VT	-	Connect the DC voltage meter to TP2.	87.5 MHz	L103	VT=1.0V±0.05V	
				108 MHz	-	Check the VT=7.0V±1.0V	

MW SECTION

NO.	ITEM	INPUT SETTING	OUTPUT SETTING	TUNER SETTING	ALIGNMENT POINTS	ALIGN FOR	FIG.
1.	IF	(A) 531 kHz or 530 kHz 1 kHz, 30% MOD 60 dBu (ANT INPUT)	(B)	531 kHz or 530 kHz	T102	Maximum output (Minimum distortion)	
2.	LOWEND TRACKING	(A) 531 kHz or 530 kHz 1 kHz, 30% MOD 30 dBu (ANT INPUT)	(B)	531 kHz or 530 kHz	L104	Maximum output	
3.	HIGHEND TRACKING	(A) 1602 kHz or 1610 kHz 1 kHz, 30% MOD 30 dBu (ANT INPUT)	(B)	1602 kHz or 1610 kHz	TC102	Maximum output	
4.	VT	-	Connect the DC voltage meter to TP2.	531 kHz	L105	VT=1.2V±0.05V	
				1602 kHz	-	Check the VT=7.3V±1.0V	

SW SECTION

NO.	ITEM	INPUT SETTING	OUTPUT SETTING	TUNER SETTING	ALIGNMENT POINTS	ALIGN FOR	FIG.
1.	IF	5.95 MHz 1 kHz, 30% MOD 60 dBu (ANT INPUT) (D)	(B)	5.95 MHz	T102	Maximum output (Minimum distortion)	
2.	LOWEND TRACKING	5.95 MHz 1 kHz, 30% MOD 30 dBu (ANT INPUT) (D)	(B)	5.95 MHz	L201	Maximum output	
3.	HIGHEND TRACKING	17.9 MHz 1 kHz, 30% MOD 30 dBu (ANT INPUT) (D)	(B)	17.9 MHz	TC201	Maximum output	
4.	VT	-	Connect the DC voltage meter to TP2.	5.95 MHz	L202	VT=1.0V±0.05V	
				17.9 MHz	-	Check the VT=8.4V±1V	

RXD-251/301/351/371S/A3

ADJUSTMENT

LW SECTION

NO.	ITEM	INPUT SETTING	OUTPUT SETTING	TUNER SETTING	ALIGNMENT POINTS	ALIGN FOR	FIG.
1.	IF	153 kHz 1 kHz, 30% MOD 60 dBu (ANT INPUT) (D)	(B)	153 kHz	T102	Maximum output (Minimum distortion)	
2.	LOW END TRACKING	153 kHz 1 kHz, 30% MOD 30 dBu (ANT INPUT) (D)	(B)	153 kHz	L201	Maximum output	
3.	HIGH END TRACKING	279 kHz 1 kHz, 30% MOD 30 dBu (ANT INPUT) (D)	(B)	279 kHz	TC201	Maximum output	
4.	VT	-	Connect the DC voltage meter to TP2.	153 kHz	L202	VT=1.0V±0.05V	
				279 kHz	-	Check the VT=5.0V±1.0V	

INSTRUMENTS CONNECTION

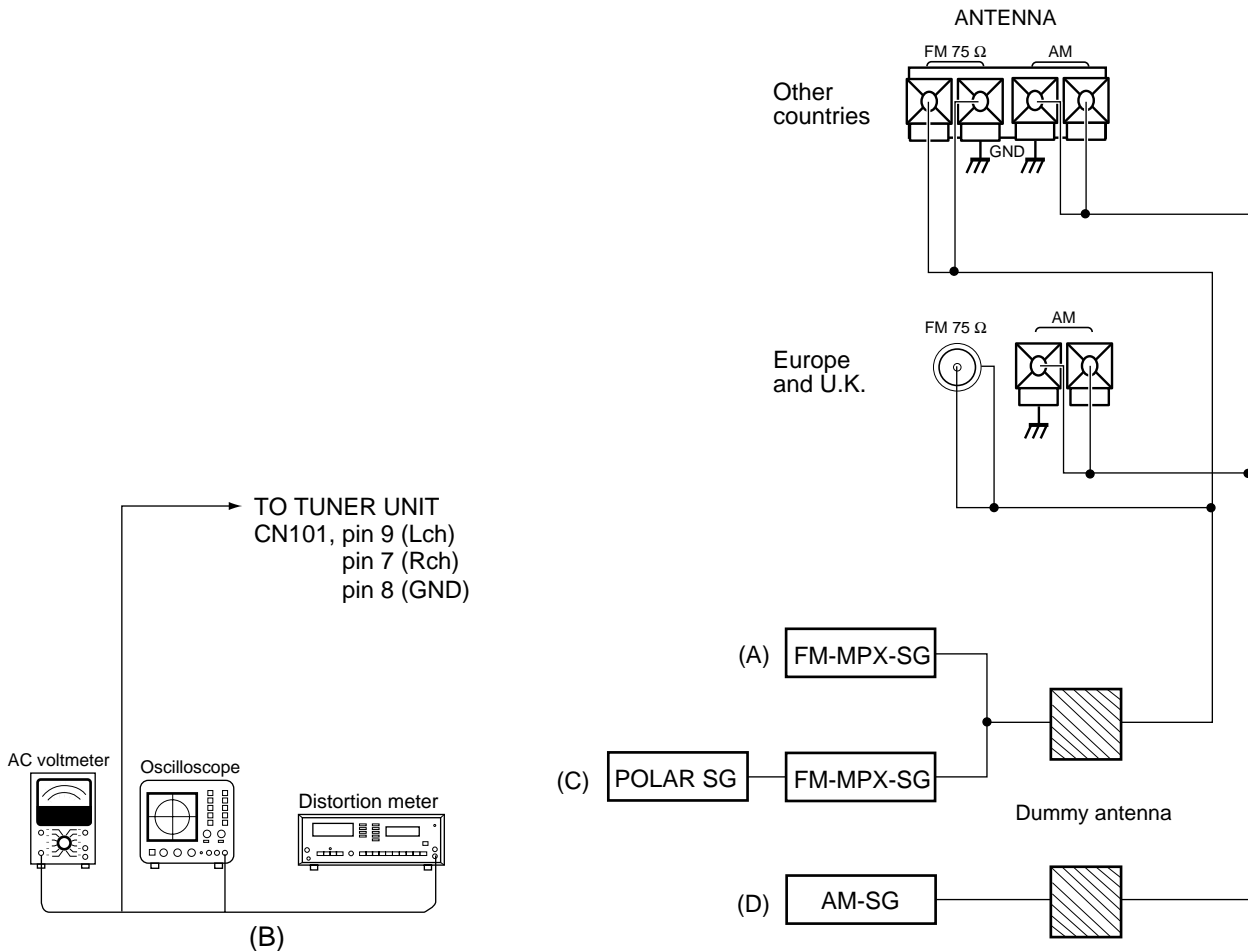

ADJUSTMENT

CASSETTE DECK SECTION

NO.	ITEM	INPUT SETTINGS	OUTPUT SETTINGS	CASSETTE TAPE DECK SETTINGS	ALIGNMENT POINT	ALGN FOR	FIG .
Unless otherwise specified : each ; switch should be set as follows : BEAT SW : OFF I. Cassette mechanism section (REC/PB head adjustment)							0dBs = 0.775V
[1]	Demagnetization and cleaning	-	-	Power OFF, demagnetization, cleaning play	REC/PB head, erase head, capstan, pinch roller	Demagnetize the REC/PB head by head eraser. Clean the REC/PB head, erase head capstan and pinch roller with a cotton swab immersed in alcohol.	
[2]	REC/PB head azimuth	MTT-114, TCC-153 SCC-1727 10 kHz, -10dB	(A)	PLAY	Azimuth adjustment screw	In a setting wher the output is maximized, adjust the azimuth adjustment screw so that the Lissajous figure appearing on the oscilloscope screen comes near to a line slanted45° Note : The head should be installed in such a manner that it approaches the tape face.	
II. PC board adjustment							
< 1 >	Tape speed	MTT-111 TCC-100 SCC-1727 3 kHz, -4 dB	(A)	PLAY	SFR201	Adjust so that Frequency is 3 kHz at the center of the tape.	
< 2 >	Playback level	TCC-120 315 Hz 0dB	(A)	PLAY		Approx. -5dBm ※ reference level	
< 3 >	Recording level	Put standard test tape (TCC-120) into B deck. Put standard blank tape into A deck.	(A)	Dubbing and playback.		Approx. -5dBm ※ reference level	

INSTRUMENTS CONNECTION

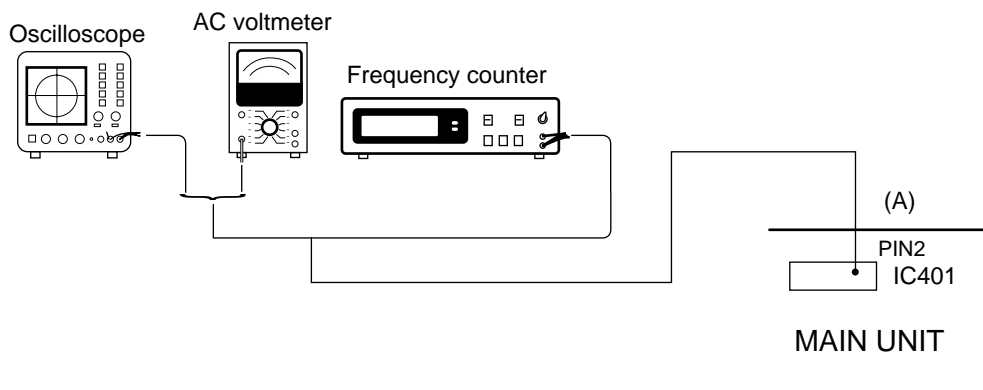

RXD-251/301/351/371S/A3

ADJUSTMENT

CD SECTION

No.	ITEM	INPUT SETTINGS	OUTPUT SETTINGS	PLAYER SETTINGS	ALIGNMENT POINTS	ALIGN FOR	FIG.
1	LASER POWER	—	Apply the sensor section of optical power meter on the pickup lens.	Press the PLAY/PAUSE key.	—	On the power from 0.08 to 0.15 mW, when the diffraction grating is correctly aligned with the RF level of 0.6 Vp-p or more.	(a)
2	FOCUS ERROR BIAS	Test disc Type 4	Connect an oscilloscope as follows. CH1 : RF (R07A) GND : VC (IC01, 48 pin)	Press the PLAY/PAUSE key.	FE BIAS VR01	Optimum eye pattern	

Note:
Type 4 disc : SONY YEDS-18 Test Disc or equivalent.(KTD-0*)

(a) Laser power

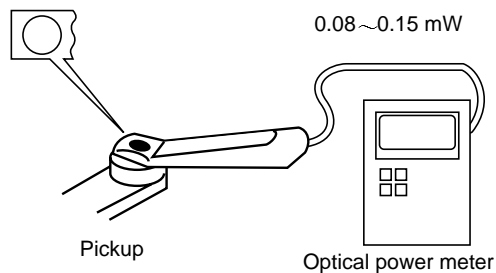

ALIGNMENT POINT

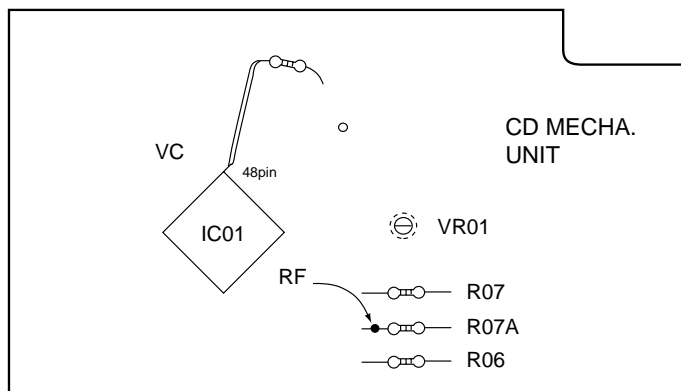

RXD-251/301/351/371S/A3

WIRING DIAGRAM

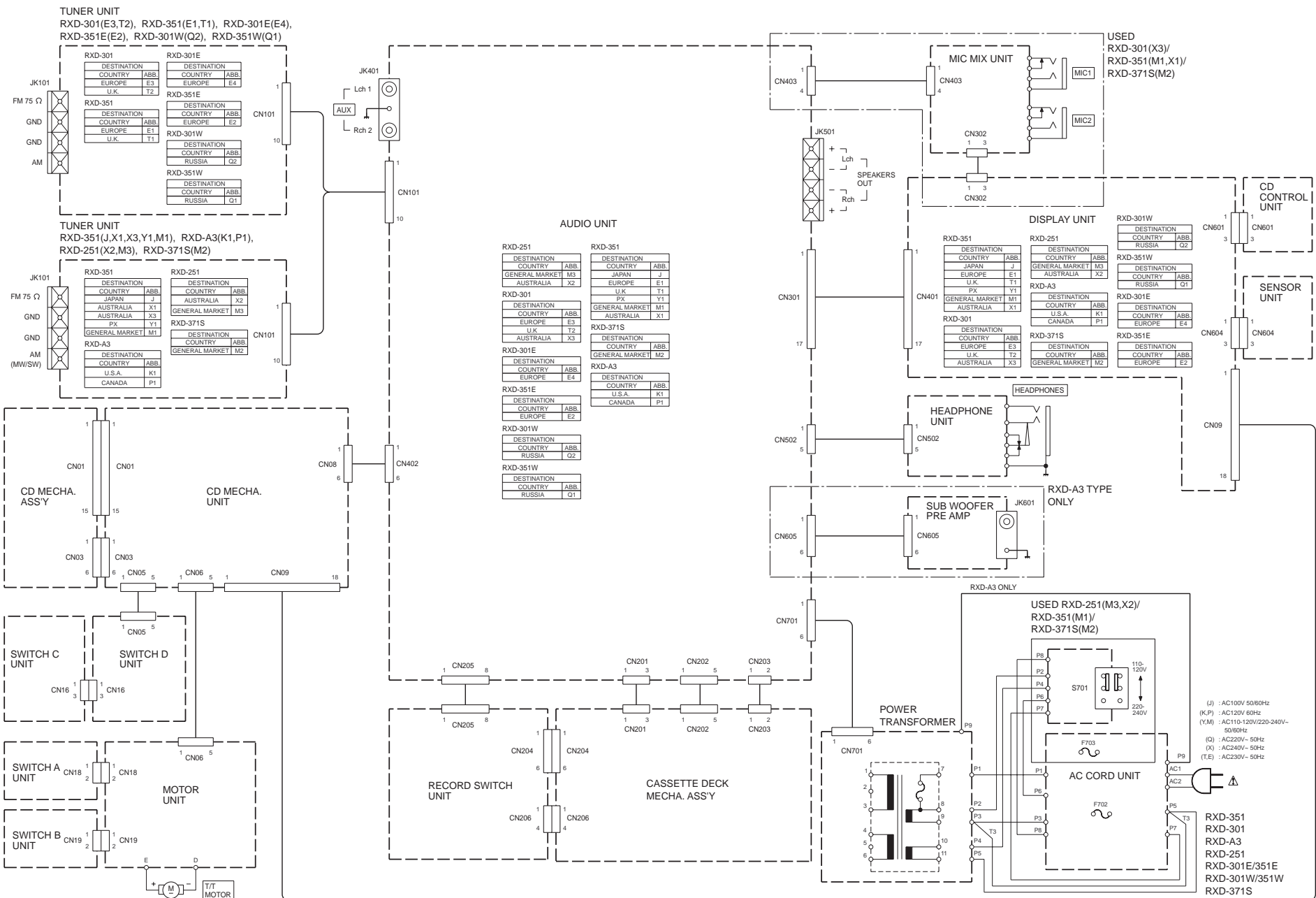

RXD-251/301/351/371S/A3

PARTS DESCRIPTIONS

CAPACITORS

CC 45 TH 1H 220 J
1 2 3 4 5 6

- 1 = Type ... ceramic, electrolytic, etc.
- 2 = Shape ... round, square, ect.
- 3 = Temp. coefficient
- 4 = Voltage rating
- 5 = Value
- 6 = Tolerance

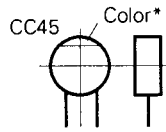

Capacitor value

- 010 = 1pF
- 100 = 10pF
- 101 = 100pF
- 102 = 1000pF = 0.001μF
- 103 = 0.01μF

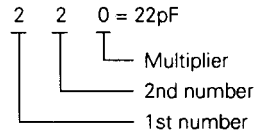

Temperature coefficient

1st Word	C	L	P	R	S	T	U
Color*	Black	Red	Orange	Yellow	Green	Blue	Violet
ppm/°C	0	-80	-150	-220	-330	-470	-750

2nd Word	G	H	J	K	L
ppm/°C	±30	±60	±120	±250	±500

Example : CC45TH = -470 ± 60ppm/°C

Tolerance (More than 10pF)

Code	C	D	G	J	K	M	X	Z	P	No code
(%)	±0.25	±0.5	±2	±5	±10	±20	+40	+80	+100	More than 10μF -10 ~ +50
							-20	-20	-0	Less than 4.7μF -10 ~ +75

(Less than 10pF)

Code	B	C	D	F	G
(pF)	±0.1	±0.25	±0.5	±1	±2

Voltage rating

2nd word	A	B	C	D	E	F	G	H	J	K	V
1st word											
0	1.0	1.25	1.6	2.0	2.5	3.15	4.0	5.0	6.3	8.0	-
1	10	12.5	16	20	25	31.5	40	50	63	80	35
2	100	125	160	200	250	315	400	500	630	800	-
3	1000	1250	1600	2000	2500	3150	4000	5000	6300	8000	-

Chip capacitors

(EX) C C 7 3 F S L 1 H 0 0 0 J
1 2 3 4 5 6 7

(Chip) (CH, RH, UJ, SL)

(EX) C K 7 3 F F 1 H 0 0 0 Z
1 2 3 4 5 6 7

(Chip) (B, F)

- 1 = Type
- 2 = Shape
- 3 = Dimension
- 4 = Temp. coefficient
- 5 = Voltage rating
- 6 = Value
- 7 = Tolerance

Dimension (Chip capacitors)

Dimension code	L	W	T
Empty	5.6 ± 0.5	5.0 ± 0.5	Less than 2.0
A	4.5 ± 0.5	3.2 ± 0.4	Less than 2.0
B	4.5 ± 0.5	2.0 ± 0.3	Less than 2.0
C	4.5 ± 0.5	1.25 ± 0.2	Less than 1.25
D	3.2 ± 0.4	2.5 ± 0.3	Less than 1.5
E	3.2 ± 0.2	1.6 ± 0.2	Less than 1.25
F	2.0 ± 0.3	1.25 ± 0.2	Less than 1.25
G	1.6 ± 0.2	0.8 ± 0.2	Less than 1.0

RESISTORS

Chip resistor (Carbon)

(EX) R K 7 3 E B 2 B 0 0 0 J
1 2 3 4 5 6 7

(Chip) (B,F)

Carbon resistor (Normal type)

(EX) R D 1 4 B B 2 C 0 0 0 J
1 2 3 4 5 6 7

- 1 = Type
- 2 = Shape
- 3 = Dimension
- 4 = Temp. coefficient
- 5 = Rating wattage
- 6 = Value
- 7 = Tolerance

Dimension

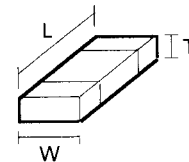

Dimension (Chip resistor)

Dimension code	L	W	T
E	3.2 ± 0.2	1.6 ± 0.2	1.0
F	2.0 ± 0.3	1.25 ± 0.2	1.0
G	1.6 ± 0.2	0.8 ± 0.2	0.5 ± 0.1

Rating wattage

Code	Wattage	Code	Wattage	Code	Wattage
1J	1/16W	2C	1/6W	3A	1W
2A	1/10W	2E	1/4W	3D	2W
2B	1/8W	2H	1/2W		

PC BOARD (Component side view)

TUNER UNIT (K1P1Y1M1X1X2M3X3)

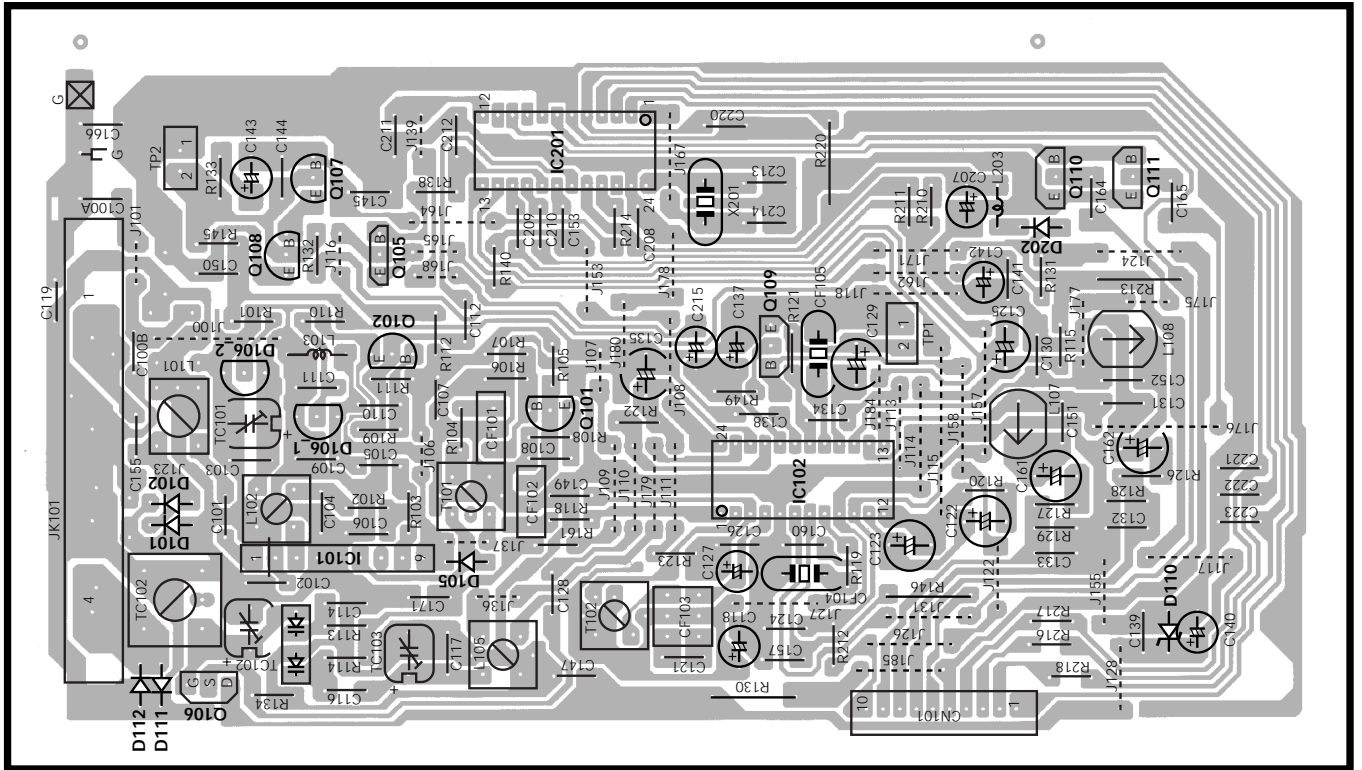

TUNER UNIT (E1T1Q1E2T2Q2E3E4)

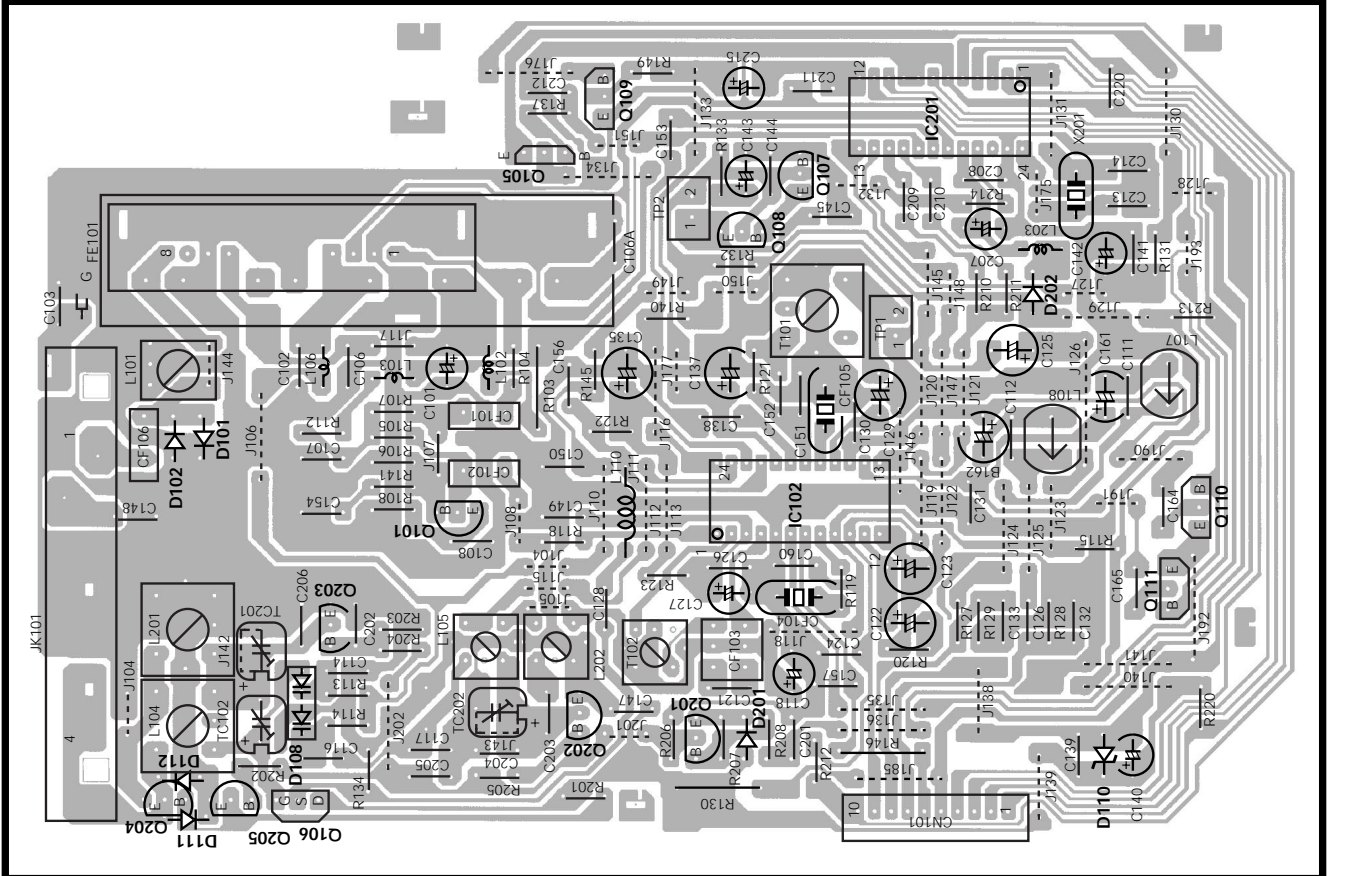

Refer to the schematic diagram for the value of resistors and capacitors.

PC BOARD (Component side view)

TUNER UNIT : RXD-371S (M2)

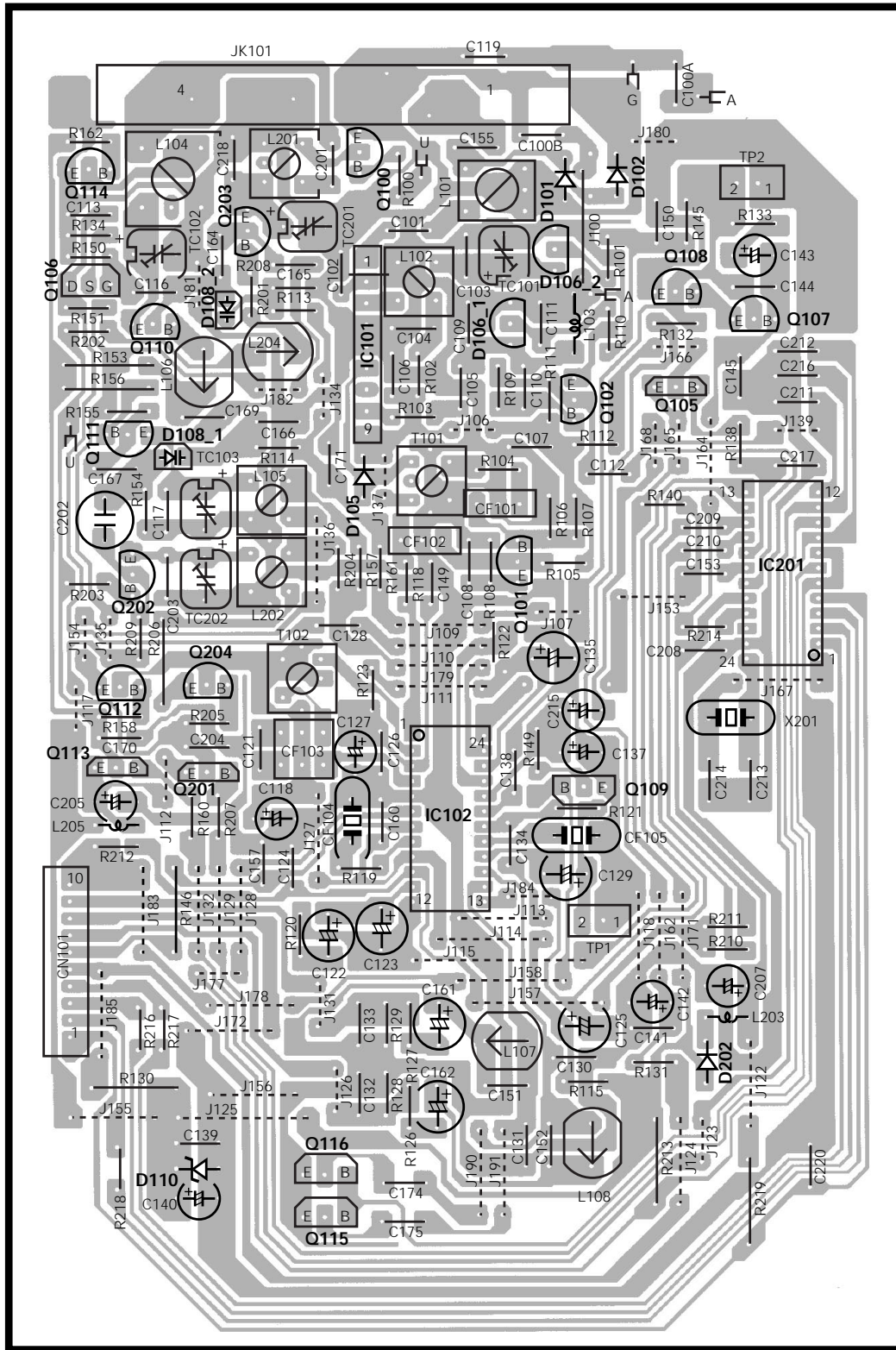

Refer to the schematic diagram for the value of resistors and capacitors.

PC BOARD (Component side view)

AUDIO UNIT

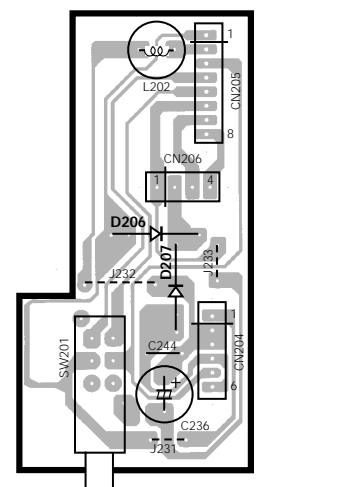
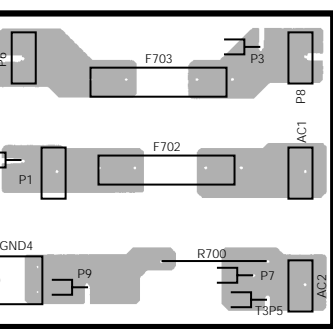
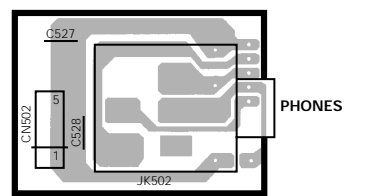
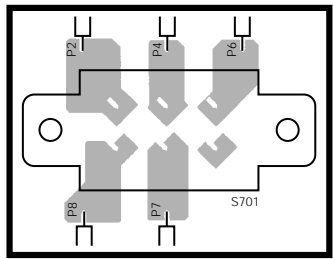
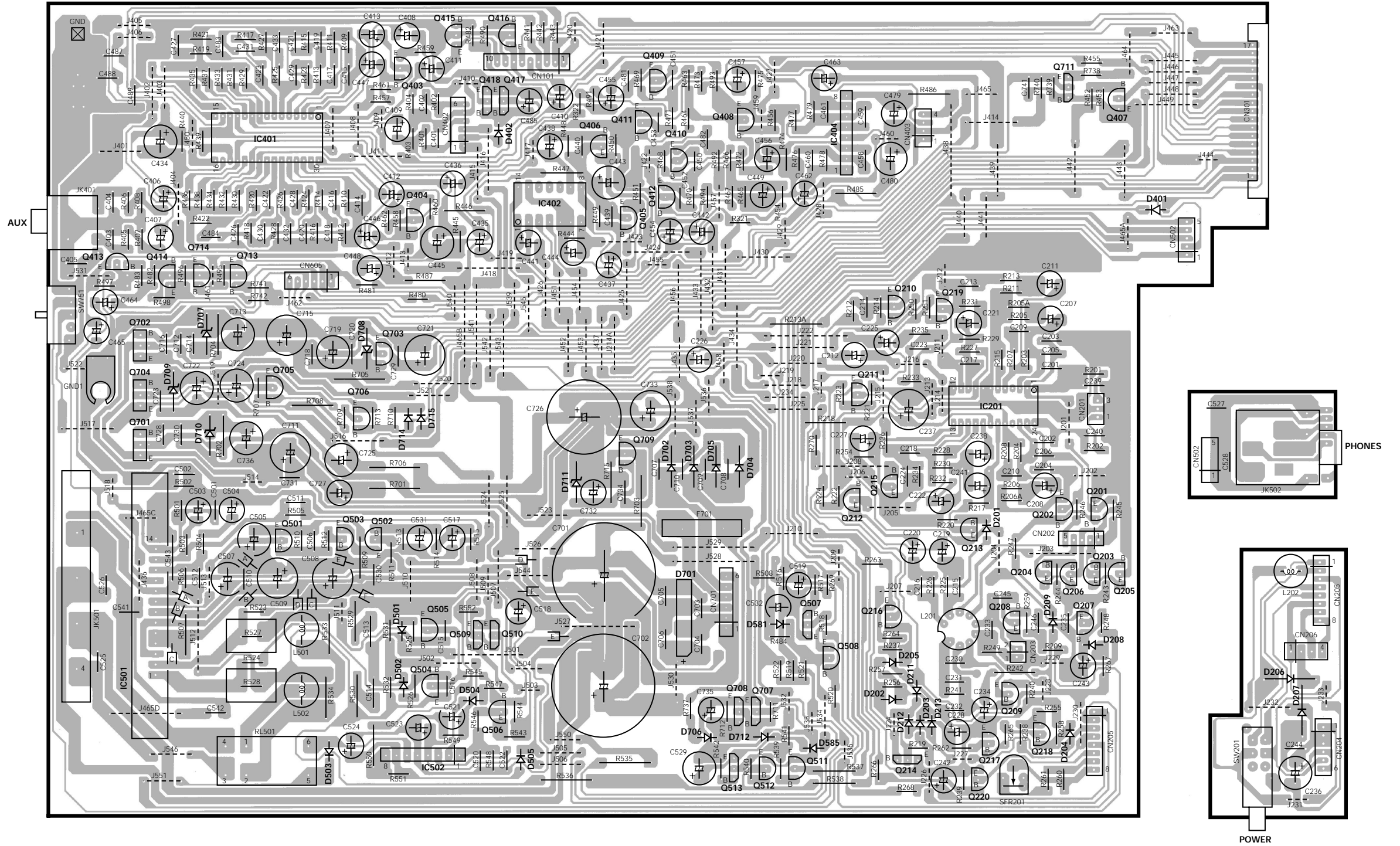

PC BOARD (Component side view)

DISPLAY UNIT

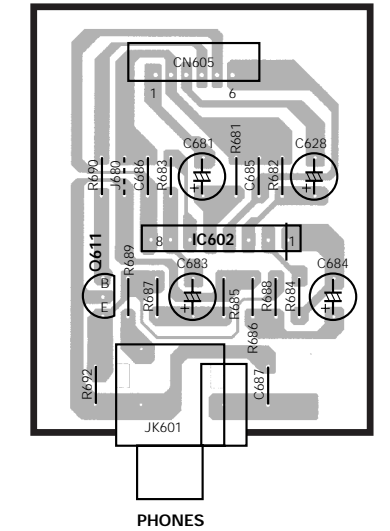
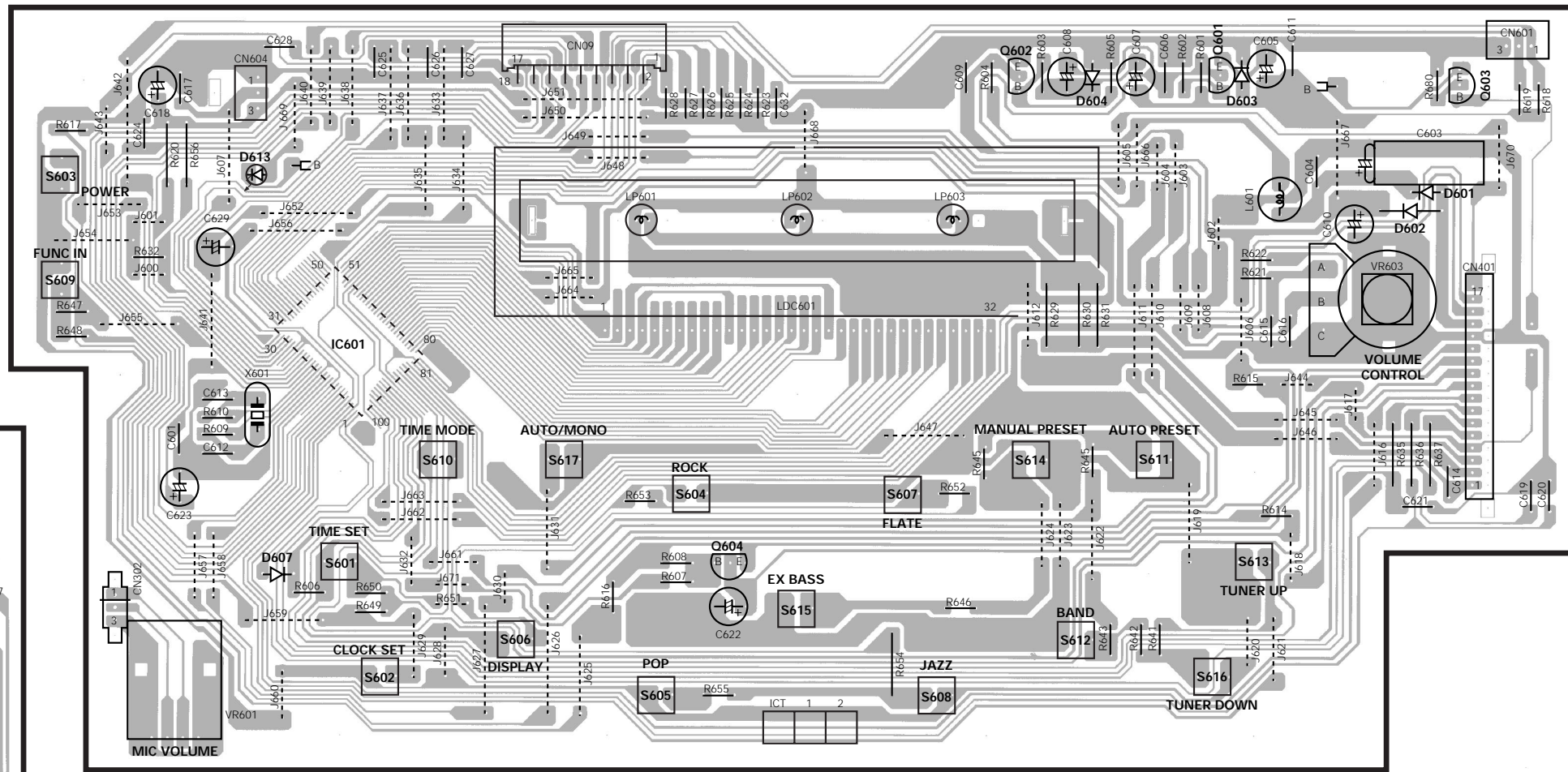
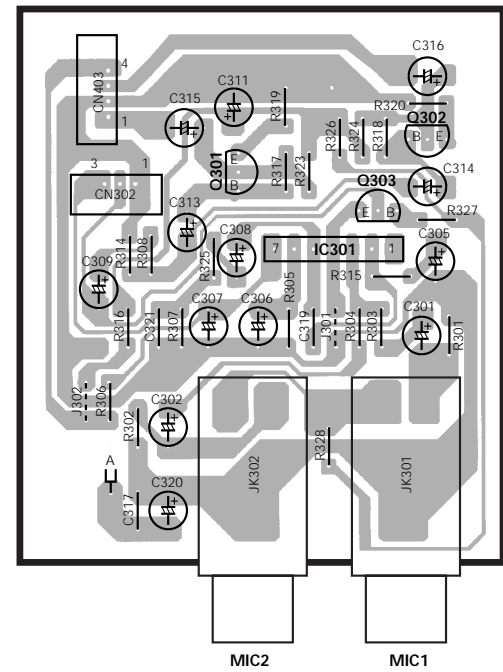
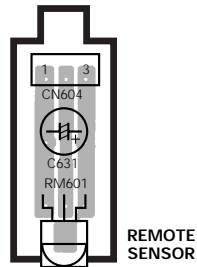
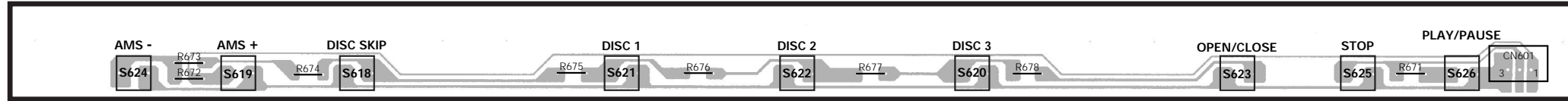

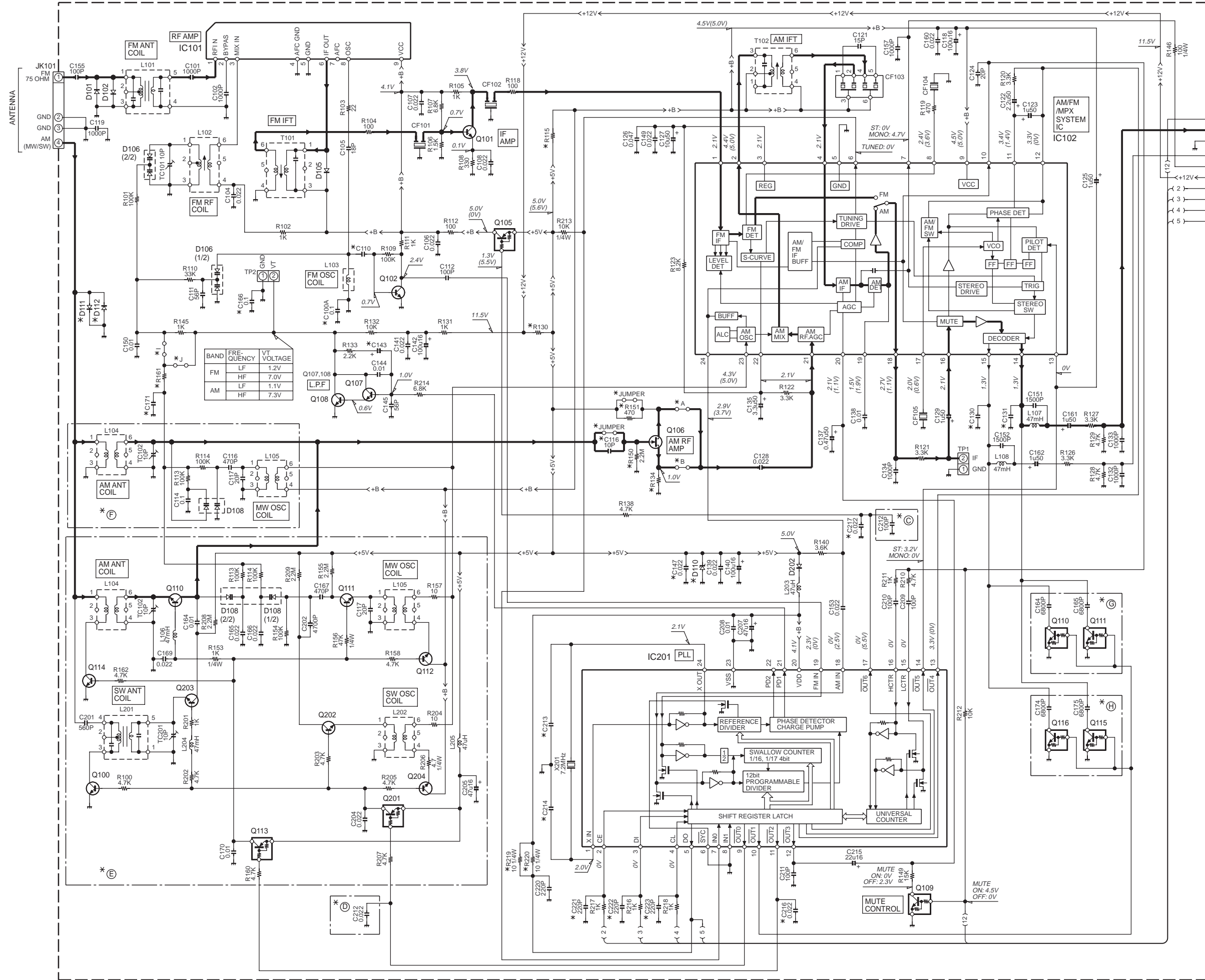

RXD-301/351

DESTINATION	COUNTRY	ABB.	A.D.E.	B.C.	F1	G	D110	D111, 112	C100A,147, 221-223	C110	C116	C117	C130, 131	C143	C166, 216,217	C171	C213, 214	R115	R130	R134	R150, 219	R151	R161	R220	Q110, 111	JUMPER
JAPAN	X1																									
AUSTRALIA	X3	NO	YES	NO	NO	NO	MT25.6B	YES	YES	2.2P	470P	20P	0.015	1u50	NO	0.1	24P	22	150 1/2W	3.3K	NO	NO	2.2K	YES	NO	YES
U.S.A.	K1																									
GENERAL MARKET	M1																									DTC114YS

RXD-A3

DESTINATION	COUNTRY	ABB.	A.D.E.	B.C.	F1	G	D110	D111, 112	C100A,147, 221-223	C110	C116	C117	C130, 131	C143	C166, 216,217	C171	C213, 214	R115	R130	R134	R150, 219	R151	R161	R220	Q110, 111	JUMPER
JAPAN	X1																									
AUSTRALIA	X3	NO	YES	NO	NO	NO	MT25.6B	YES	YES	2.2P	470P	20P	0.022	1u50	NO	0.1	24P	22	150 1/2W	3.3K	NO	NO	2.2K	YES	NO	YES
U.S.A.	K1																									
GENERAL MARKET	P1																									NO

RXD-251

DESTINATION	COUNTRY	ABB.	A.D.E.	B.C.	F1	G	D110	D111, 112	C100A,147, 221-223	C110	C116	C117	C130, 131	C143	C166, 216,217	C171	C213, 214	R115	R130	R134	R150, 219	R151	R161	R220	Q110, 111	JUMPER
JAPAN	X1																									
AUSTRALIA	X3	NO	YES	NO	NO	NO	MT25.6B	YES	YES	2.2P	470P	20P	0.015	1u50	NO	0.1	24P	22	150 1/2W	3.3K	NO	NO	2.2K	YES	NO	YES
U.S.A.	K1																									
GENERAL MARKET	M3																									NO

RXD-371S

DESTINATION	COUNTRY	ABB.	A.D.E.	B.C.	F1	G	D110	D111, 112	C100A,147, 221-223	C110	C116	C117	C130, 131	C143	C166, 216,217	C171	C213, 214	R115	R130	R134	R150, 219	R151	R161	R220	Q110, 111	JUMPER
JAPAN	X1																									
AUSTRALIA	X3	NO	YES	NO	NO	NO	MT26.2B	NO	NO	4.7P	10P	5.6P	0.015	3.3u50	YES	0.022	27P	47	100 1/2W	10	YES	YES	4.7K	NO	25C2878A	NO
U.S.A.	K1																									
GENERAL MARKET	M2																									NO

- IC101 : LA1186N
- IC102 : LA1831
- IC201 : LC7218
- Q100,114 : 2SC2001(L)
- Q101 : 2SC1675(L)
- Q102 : 2SC1674(L)
- Q105 : DTA114YS
- Q106 : 2SK161(GR)
- Q107,108 : 2SC945(Q)
- Q109,115,116 : DTC114YS
- Q110,111 : *
- Q112,202-204 : 2SC2878A
- Q113,201 : DTA144ES
- D101,102,105,111,112,202 : 1S5133
- D106 : KV1340A
- D108 : KV1581A
- D110 : *

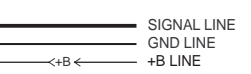

CAUTION: For continued safety, replace safety critical components only with manufacturer's recommended parts (refer to parts list). indicates safety critical components. For continued protection against risk of fire, replace only with same type and rating fuse(s). To reduce the risk of electric shock, leakage-current or resistance measurements shall be carried out (exposed parts are acceptably insulated from the supply circuit) before the appliance is returned to the customer.

The DC voltage is an actual reading measured with a high impedance type voltmeter as the AM/FM signal generator is specified to the conditions as shown in the list below. The measurement value may vary depending on the measuring instruments used or on the product. The value shown in () is actual reading measured in the AM mode.

MODE	CARRIER	MODULATION		ANT INPUT
		FREQUENCY	DEVIATION	
FM	98MHz	1kHz	STEREO 67.5kHz 7.5kHz(Pilot)	60dB
AM	1000(999)kHz	400Hz	MONO 30% MOD	60dB

RXD-351(J,X1,Y1,M1) (1/5)
 RXD-A3(K1,P1) (1/5)
 RXD-251(X2,M3) (1/5)
 RXD-371S(M2) (1/5)

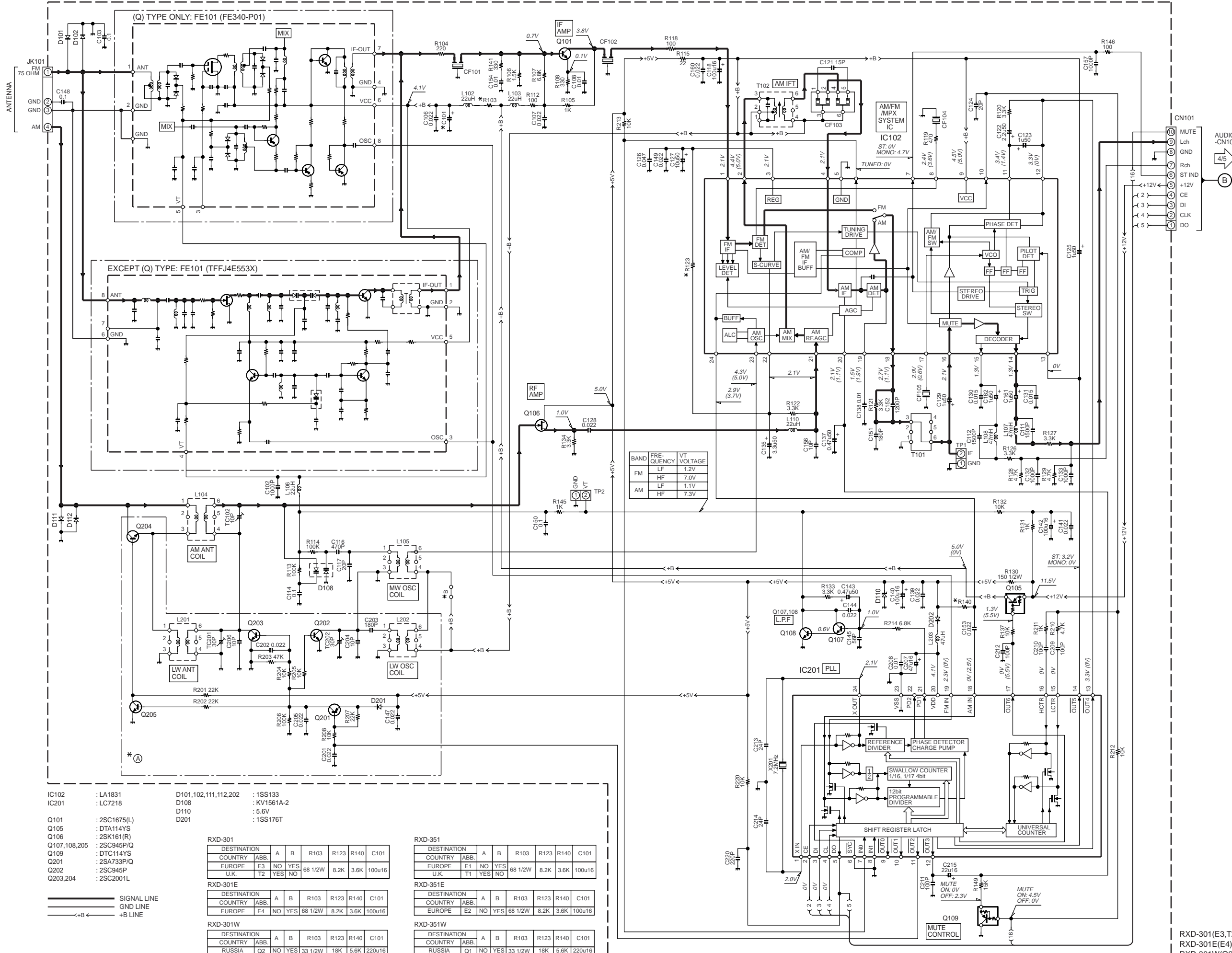

CAUTION: For continued safety, replace safety critical components only with manufacturer's recommended parts (refer to parts list). indicates safety critical components. For continued protection against risk of fire, replace only with same type and rating fuse(s). To reduce the risk of electric shock, leakage-current or resistance measurements shall be carried out (exposed parts are acceptably insulated from the supply circuit) before the appliance is returned to the customer.

The DC voltage is an actual reading measured with a high impedance type voltmeter as the AM/FM signal generator is specified to the conditions as shown in the list below. The measurement value may vary depending on the measuring instruments used or on the product. The value shown in () is actual reading measured in the AM mode.

MODE	CARRIER	MODULATION		ANT INPUT
		FREQUENCY	DEVIATION	
FM	98MHz	1kHz	STEREO 67.5kHz 7.5kHz(Pilot)	60dB
AM	1000(999)kHz	400Hz	MONO 30% MOD	60dB

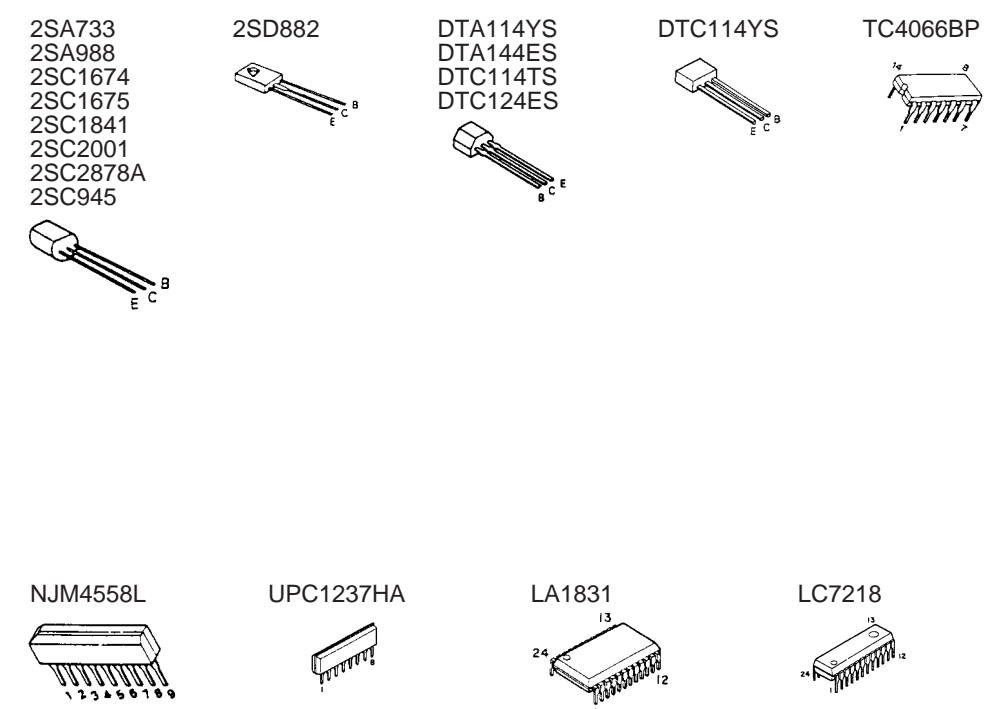

RXD-301(E3,T2)/351(E1,T1) (2/5)
 RXD-301E(E4)/351E(E2) (2/5)
 RXD-301W(Q2)/351W(Q1) (2/5)

Y39-2930-11

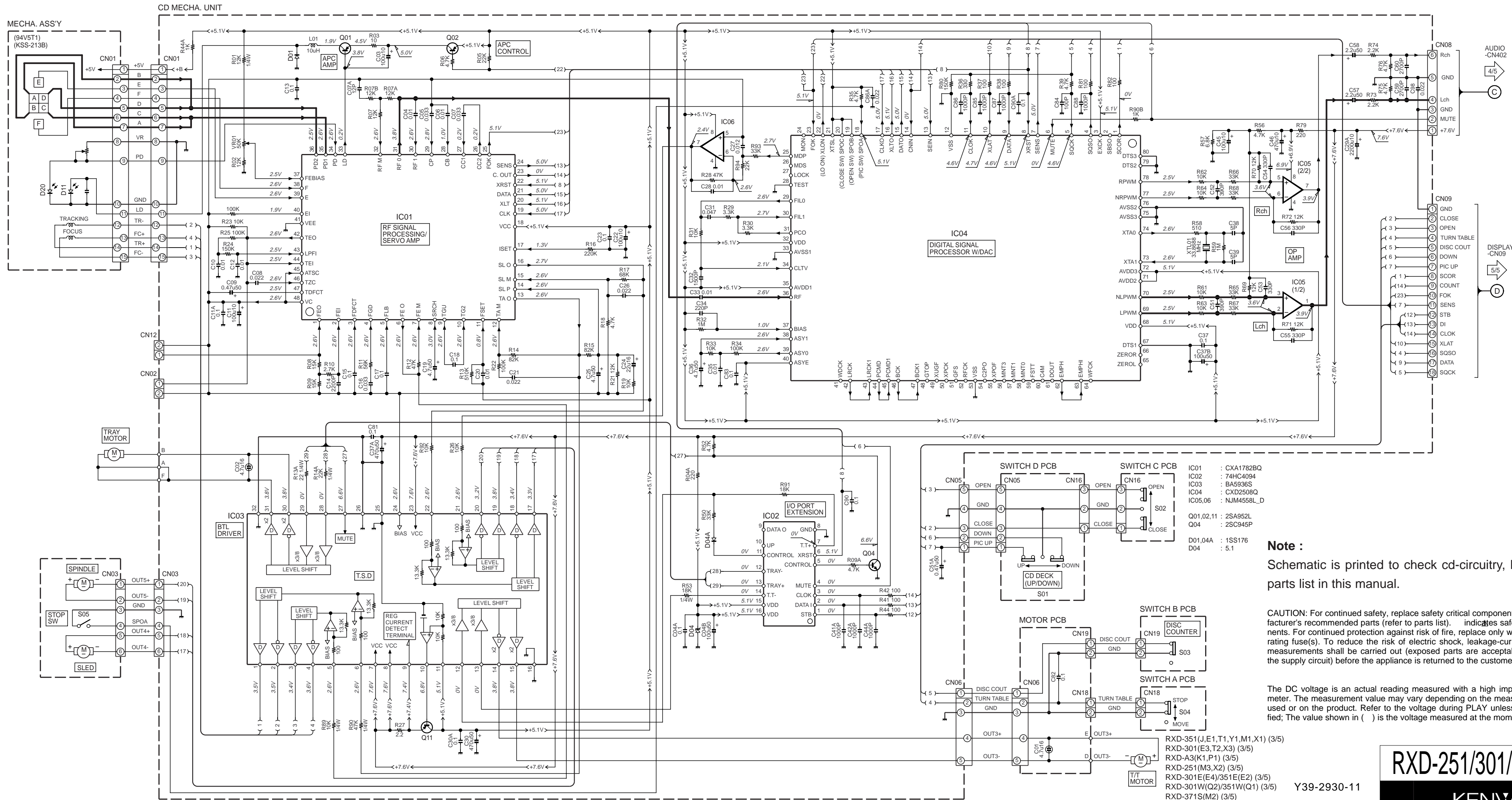

- IC01 : CXA1782BQ
- IC02 : 74HC4094
- IC03 : BA5936S
- IC04 : CXD2508Q
- IC05,06 : NJM4558L-D
- Q01,02,11 : 2SA952L
- Q04 : 2SC945P
- D01,04A : 1SS176
- D04 : 5.1

Note :
Schematic is printed to check cd-circuitry, however, no parts list in this manual.

CAUTION: For continued safety, replace safety critical components only with manufacturer's recommended parts (refer to parts list). indicates safety critical components. For continued protection against risk of fire, replace only with same type and rating fuse(s). To reduce the risk of electric shock, leakage-current or resistance measurements shall be carried out (exposed parts are acceptably insulated from the supply circuit) before the appliance is returned to the customer.

The DC voltage is an actual reading measured with a high impedance type voltmeter. The measurement value may vary depending on the measuring instruments used or on the product. Refer to the voltage during PLAY unless otherwise specified; The value shown in () is the voltage measured at the moment of STOP.

- RXD-351(J,E1,T1,Y1,M1,X1) (3/5)
- RXD-301(E3,T2,X3) (3/5)
- RXD-A3(K1,P1) (3/5)
- RXD-251(M3,X2) (3/5)
- RXD-301E(E4)/351E(E2) (3/5)
- RXD-301W(Q2)/351W(Q1) (3/5)
- RXD-371S(M2) (3/5)

Y39-2930-11

RXD-251/301/351/371S/A3

KENWOOD

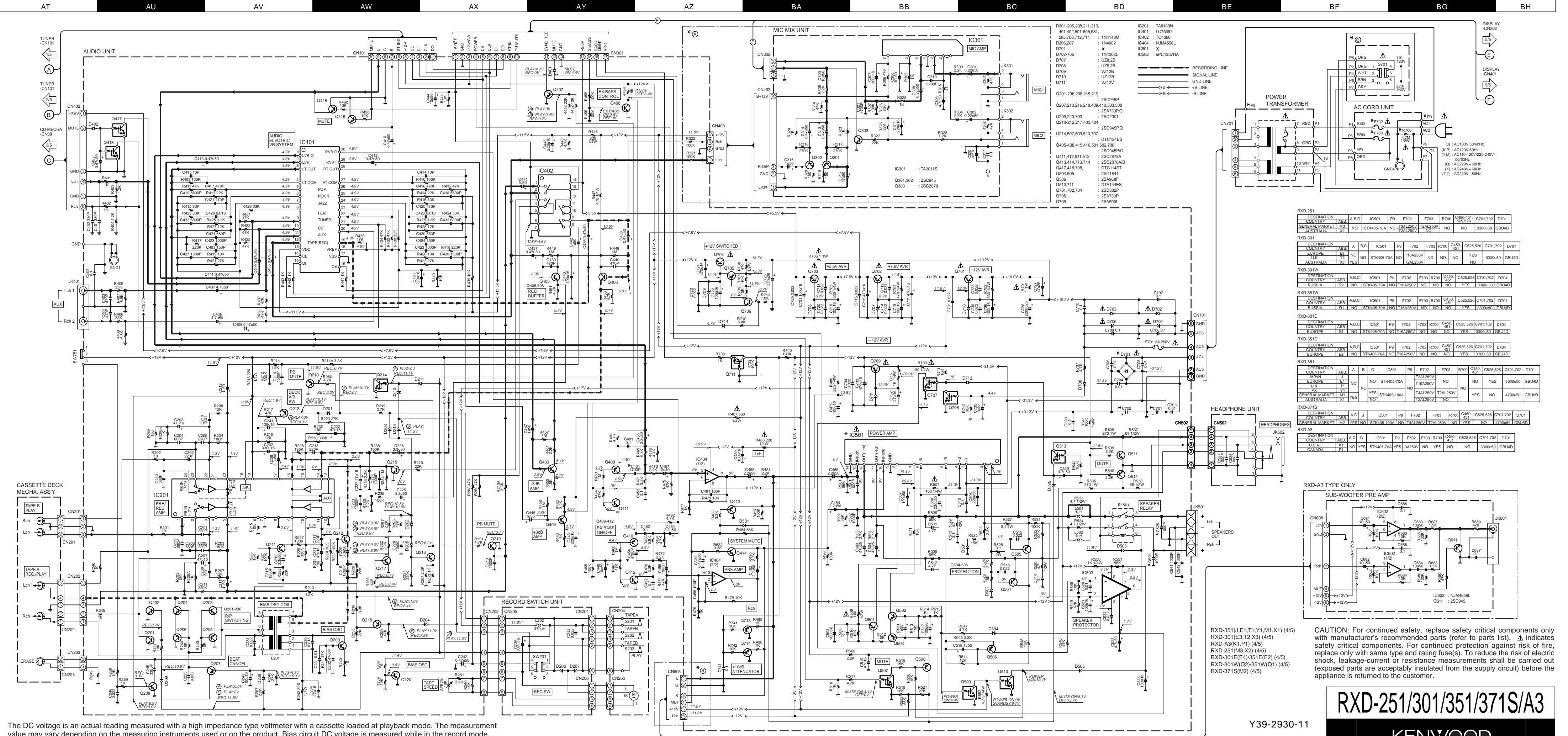

The DC voltage is an actual reading measured with a high impedance type voltmeter with a cassette loaded at playback mode. The measurement value may vary depending on the measuring instruments used or on the product. Bias circuit DC voltage is measured while in the record mode.

Y39-2930-11

RXD-251/301/351/371S/A3

KENWOOD

RXD-251														
DESTINATION	COUNTRY	ABB.	A	B	C	IC501	P9	F702	F703	R700	C450, C451	C525, C526	C701, C702	D701
GENERAL MARKET	M1	NO	NO	NO	NO	STK405-70A	NO	T2AL250V	NO	NO	NO	NO	3300u50	GBU4D
AUSTRALIA	X2	YES	NO	NO	NO	NO	NO	T2AL250V	NO	NO	NO	NO	NO	NO

RXD-301														
DESTINATION	COUNTRY	ABB.	A	B	C	IC501	P9	F702	F703	R700	C450, C451	C525, C526	C701, C702	D701
EUROPE	E3	NO	NO	NO	NO	STK405-70A	NO	T16A250V	NO	NO	NO	YES	3300u50	GBU4D
RUSSIA	G2	NO	NO	NO	NO	STK405-70A	NO	T2AL250V	NO	NO	NO	NO	NO	NO
AUSTRALIA	X3	YES	NO	NO	NO	NO	NO	T2AL250V	NO	NO	NO	NO	NO	NO

RXD-301W														
DESTINATION	COUNTRY	ABB.	A	B	C	IC501	P9	F702	F703	R700	C450, C451	C525, C526	C701, C702	D704
EUROPE	E4	NO	NO	NO	NO	STK405-70A	NO	T16A250V	NO	NO	NO	YES	3300u50	GBU4D
RUSSIA	G1	NO	NO	NO	NO	STK405-70A	NO	T16A250V	NO	NO	NO	NO	NO	NO

RXD-301E														
DESTINATION	COUNTRY	ABB.	A	B	C	IC501	P9	F702	F703	R700	C450, C451	C525, C526	C701, C702	D704
EUROPE	E4	NO	NO	NO	NO	STK405-70A	NO	T16A250V	NO	NO	NO	YES	3300u50	GBU4D
RUSSIA	E2	NO	NO	NO	NO	STK405-70A	NO	T16A250V	NO	NO	NO	NO	NO	NO

RXD-351														
DESTINATION	COUNTRY	ABB.	A	B	C	IC501	P9	F702	F703	R700	C450, C451	C525, C526	C701, C702	D701
JAPAN	J	NO	NO	NO	NO	STK405-70A	NO	T2AL250V	NO	NO	NO	NO	NO	NO
EUROPE	E1	NO	NO	NO	NO	STK405-70A	NO	T16A250V	NO	NO	NO	NO	NO	NO
U.K.	T1	NO	NO	NO	NO	NO	NO	T4AL250V	NO	NO	NO	NO	NO	NO
GENERAL MARKET	M1	YES	NO	NO	NO	STK405-100A	NO	T2AL250V	NO	NO	NO	YES	NO	4700u50
AUSTRALIA	X1	YES	NO	NO	NO	NO	NO	T2AL250V	NO	NO	NO	NO	NO	4700u50

RXD-371S														
DESTINATION	COUNTRY	ABB.	A	B	C	IC501	P9	F702	F703	R700	C450, C451	C525, C526	C701, C702	D701
GENERAL MARKET	M2	YES	NO	NO	NO	STK405-100A	NO	T4AL250V	NO	NO	NO	YES	NO	4700u50
EUROPE	E2	NO	NO	NO	NO	STK405-70A	YES	3A250V	NO	NO	NO	NO	NO	3300u50
CANADA	P1	NO	NO	NO	NO	NO	NO	T2AL250V	NO	NO	NO	NO	NO	3300u50

CAUTION: For continued safety, replace safety critical components only with manufacturer's recommended parts (refer to parts list). Δ indicates safety critical components. For continued protection against risk of fire, replace only with same type and rating fuse(s). To reduce the risk of electric shock, leakage-current or resistance measurements shall be carried out (exposed parts are acceptably insulated from the supply circuit) before the appliance is returned to the customer.

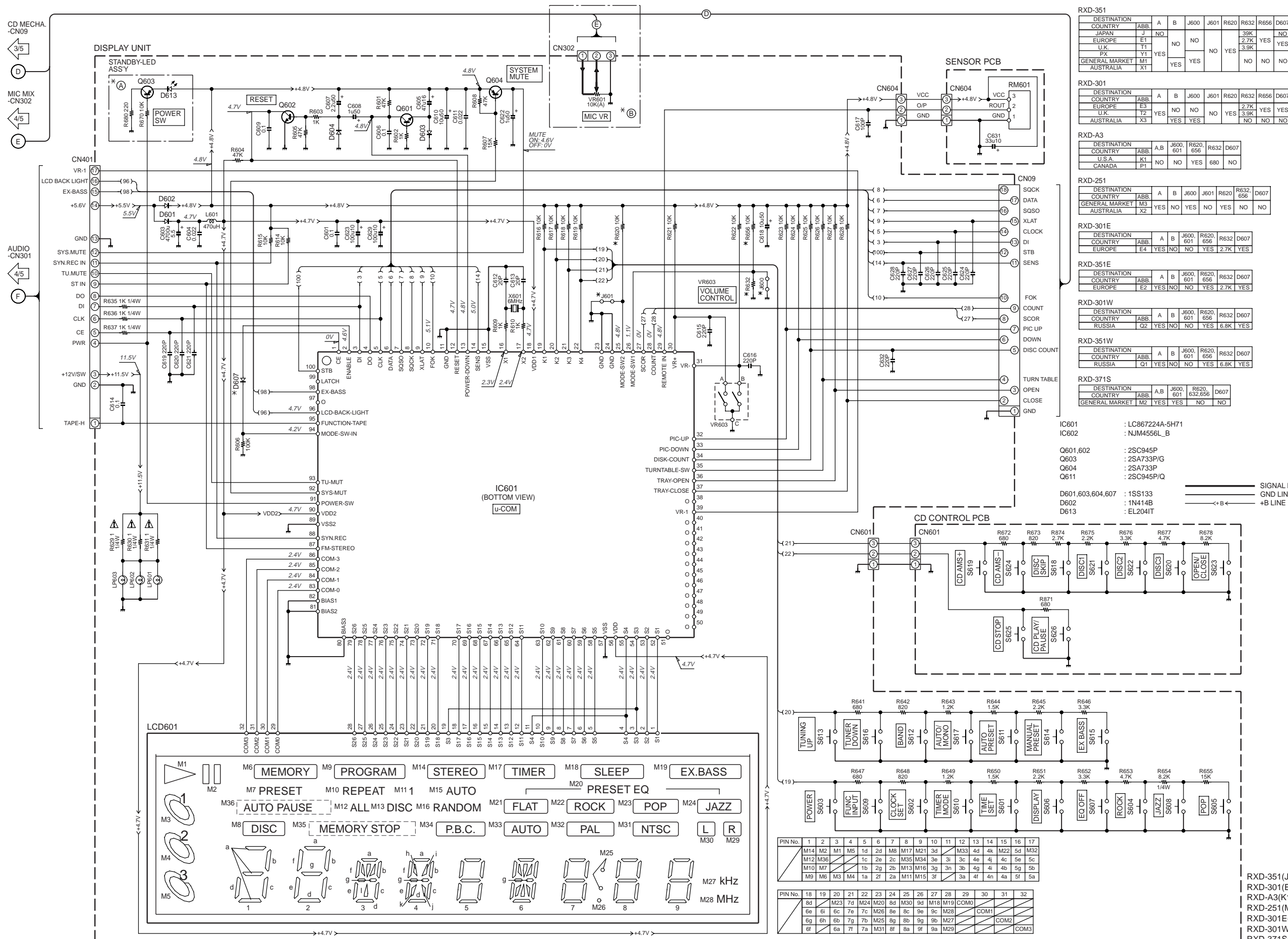

DESTINATION	COUNTRY	ABB.	A	B	J600	J601	R620	R632	R656	D607
JAPAN	J	NO	NO	NO	NO	NO	3.9K	2.7K	YES	NO
EUROPE	E1	NO	NO	NO	NO	NO	3.9K	2.7K	YES	YES
U.K.	T1	YES	NO	NO	NO	NO	3.9K	2.7K	YES	YES
FX	Y1	NO	NO	NO	NO	NO	NO	NO	NO	NO
GENERAL MARKET	M1	NO	NO	NO	NO	NO	NO	NO	NO	NO
AUSTRALIA	X1	YES	YES	YES	YES	YES	NO	NO	NO	NO

DESTINATION	COUNTRY	ABB.	A	B	J600	J601	R620	R632	R656	D607
JAPAN	J	NO	NO	NO	NO	NO	NO	NO	NO	NO
EUROPE	E3	NO	NO	NO	NO	NO	NO	NO	NO	NO
U.K.	T2	YES	NO	NO	NO	NO	NO	NO	NO	NO
AUSTRALIA	X3	YES	YES	YES	YES	YES	NO	NO	NO	NO

DESTINATION	COUNTRY	ABB.	A	B	J600	J601	R620	R632	D607
U.S.A.	K1	NO	NO	NO	NO	NO	NO	NO	NO
CANADA	P1	NO	NO	NO	NO	NO	680	NO	NO

DESTINATION	COUNTRY	ABB.	A	B	J600	J601	R620	R632	D607
JAPAN	J	NO	NO	NO	NO	NO	NO	NO	NO
EUROPE	E4	YES	NO	NO	NO	NO	NO	NO	NO
AUSTRALIA	X2	YES	NO	NO	NO	NO	NO	NO	NO

DESTINATION	COUNTRY	ABB.	A	B	J600	J601	R620	R632	D607
EUROPE	E4	YES	NO	NO	NO	NO	NO	2.7K	YES

DESTINATION	COUNTRY	ABB.	A	B	J600	J601	R620	R632	D607
EUROPE	E2	YES	NO	NO	NO	NO	NO	2.7K	YES

DESTINATION	COUNTRY	ABB.	A	B	J600	J601	R620	R632	D607
RUSSIA	Q2	YES	NO	NO	NO	NO	NO	6.8K	YES

DESTINATION	COUNTRY	ABB.	A	B	J600	J601	R620	R632	D607
RUSSIA	Q1	YES	NO	NO	NO	NO	NO	6.8K	YES

DESTINATION	COUNTRY	ABB.	A	B	J600	J601	R620	R632	D607
RUSSIA	M2	YES	YES	YES	YES	YES	NO	NO	NO

- IC601 : LC867224A-5H71
- IC602 : NJM4556L_B
- Q601,602 : 2SC945P
- Q603 : 2SA733P/G
- Q604 : 2SA733P
- Q611 : 2SC945P/Q
- D601,603,604,607 : 1SS133
- D602 : 1N414B
- D613 : EL204IT

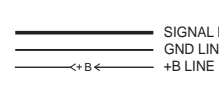

PIN No.	1	2	3	4	5	6	7	8	9	10	11	12	13	14	15	16	17
M14	M2	M1	M5	1d	2d	M8	M17	M21	3d	M33	4d	4k	M22	5d	M32		
M12	M36	1c	2c	M35	M34	3e	3i	3c	4e	4i	4c	5e	5c				
M10	M7	1b	2b	M13	M16	3g	3n	3b	4g	4i	4b	5g	5b				
M9	M6	M3	M4	1a	2i	2a	M11	M15	3f	3a	4f	4a	5f	5a			

PIN No.	18	19	20	21	22	23	24	25	26	27	28	29	30	31	32
8d	M23	7d	M24	M20	8d	M30	9d	M18	M19	COM0					
6e	6i	6c	7e	7c	M26	8e	8c	9e	9c	M28					
6g	6h	6b	7g	7b	M25	8g	8b	9g	9b	M27					
6f		6a	7i	7a	M31	8f	8a	9f	9a	M29					

- RXD-351(J,E,1,T,1,Y,1,M,1,X,1) (5/5)
- RXD-301(E,3,T,2,X,3) (5/5)
- RXD-A3(K,1,P,1) (5/5)
- RXD-251(M,3,X,2) (5/5)
- RXD-301E(E,4)/351E(E,2) (5/5)
- RXD-301W(Q,2)/351W(Q,1) (5/5)
- RXD-371S(M,2) (5/5)

CAUTION: For continued safety, replace safety critical components only with manufacturer's recommended parts (refer to parts list). Δ indicates safety critical components. For continued protection against risk of fire, replace only with same type and rating fuse(s). To reduce the risk of electric shock, leakage-current or resistance measurements shall be carried out (exposed parts are acceptably insulated from the supply circuit) before the appliance is returned to the customer.

The DC voltage is an actual reading measured with a high impedance type voltmeter with a cassette loaded at playback mode. The measurement value may vary depending on the measuring instruments used or on the product. Bias circuit DC voltage is measured while in the record mode.

RXD-251/301/351/371S/A3

EXPLODED VIEW (UNIT)

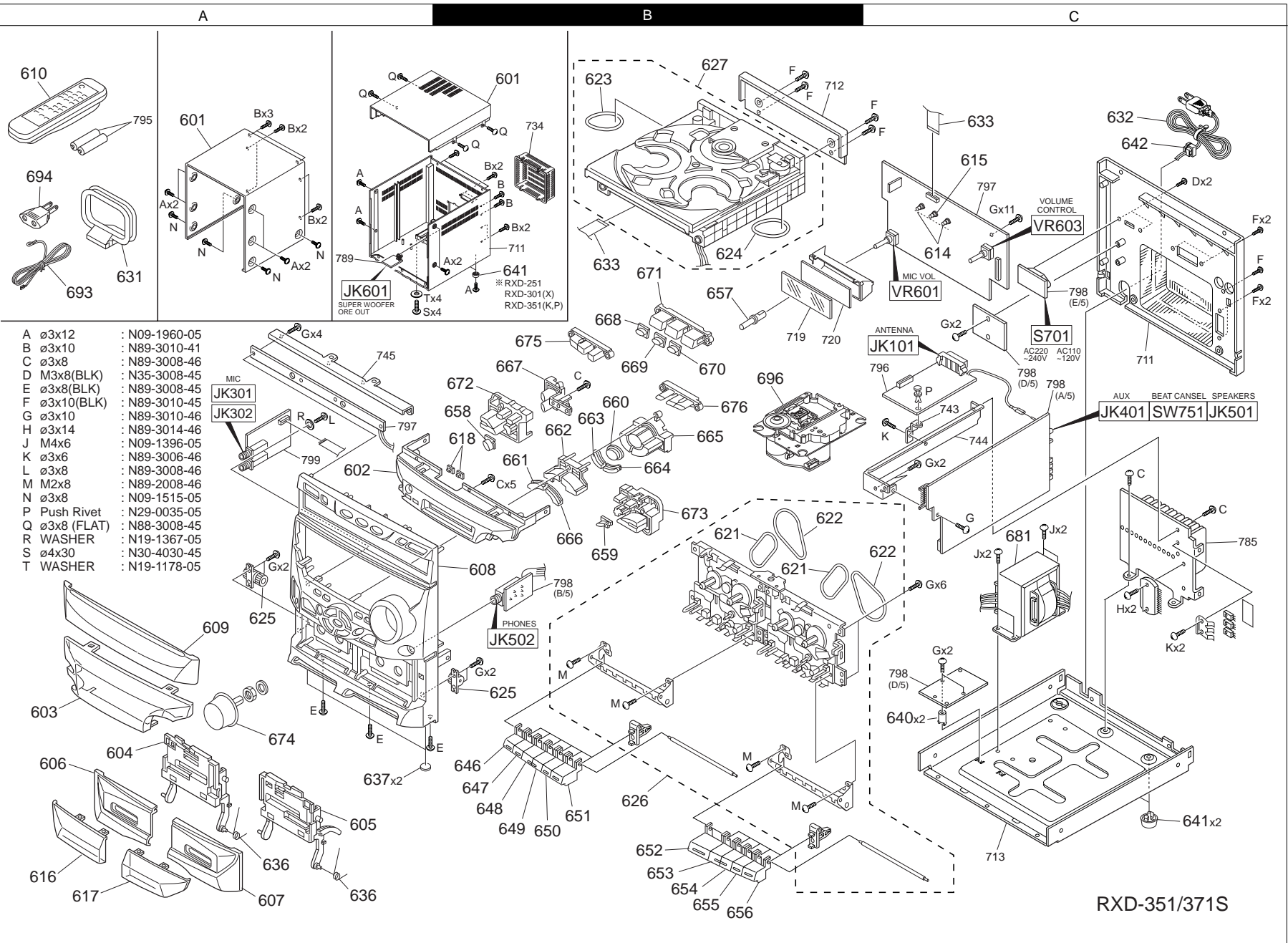

A	ø3x12	:	N09-1960-05
B	ø3x10	:	N89-3010-41
C	ø3x8	:	N89-3008-46
D	M3x8 (BLK)	:	N35-3008-45
E	ø3x8 (BLK)	:	N89-3008-45
F	ø3x10 (BLK)	:	N89-3010-45
G	ø3x10	:	N89-3010-46
H	ø3x14	:	N89-3014-46
J	M4x6	:	N09-1396-05
K	ø3x6	:	N89-3006-46
L	ø3x8	:	N89-3008-46
M	M2x8	:	N89-2008-46
N	ø3x8	:	N09-1515-05
P	Push Rivet	:	N29-0035-05
Q	ø3x8 (FLAT)	:	N88-3008-45
R	WASHER	:	N19-1367-05
S	ø4x30	:	N30-4030-45
T	WASHER	:	N19-1178-05

RXD-351/371S

* New Parts

Parts without **Parts No.** are not supplied.
Les articles non mentionnés dans le **Parts No.** ne sont pas fournis.
Teile ohne **Parts No.** werden nicht geliefert.

①

Ref. No	Add-ress	New Parts	Parts No.	Description	Desti-nation	Re-marks
RXD-251/301/301E/301W/351/351E/351W/371S/A5						
601	1A	*	A01-3676-08	CABINET BLACK	X3	B
601	1A	*	A01-3677-08	CABINET GRAY	K1P1X2 H	
601	1A	*	A01-3677-08	CABINET GRAY	M3 H	
601	1A	*	A01-3678-08	CABINET(METAL)SILVER	E2M2	S
601	1A	*	A01-3678-08	CABINET(METAL)SILVER	M1X1Y1	S
601	1A	*	A01-3678-08	CABINET(METAL)SILVER	T1E1Q1	S
601	1A	*	A01-3679-08	CABINET(METAL)BLACK	E4	B
601	1A	*	A01-3679-08	CABINET(METAL)BLACK	T2Q2E3	B
602	1A	*	A22-1817-08	SUB PANEL	K1P1	
602	1A	*	A22-1818-08	SUB PANEL	M1X1Y1	
602	1A	*	A22-1818-08	SUB PANEL	M2X2M3	
602	1A	*	A22-1818-08	SUB PANEL	T1E1Q1	
602	1A	*	A22-1818-08	SUB PANEL	T2E2Q2	
602	1A	*	A22-1818-08	SUB PANEL	X3E3E4	
603	2A	*	A29-1040-08	FRONT GLASS	K1P1	
603	2A	*	A29-1041-08	FRONT GLASS	E3E4	
603	2A	*	A29-1041-08	FRONT GLASS	T2Q2X3	
603	2A	*	A29-1042-08	FRONT GLASS	E2	
603	2A	*	A29-1042-08	FRONT GLASS	M1X1Y1	
603	2A	*	A29-1042-08	FRONT GLASS	T1E1Q1	
603	2A	*	A29-1043-08	FRONT GLASS	M2	
603	2A	*	A29-1044-08	FRONT GLASS	M3X2	
604	2A	*	A53-2097-08	CASSETTE HOLDER(L)		
605	2A	*	A53-2098-08	CASSETTE HOLDER(R)		
606	2A	*	A53-2099-08	CASSETTE LID(L) BLACK	E3E4	B
606	2A	*	A53-2099-08	CASSETTE LID(L) BLACK	T2Q2X3	B
606	2A	*	A53-2101-08	CASSETTE LID(L) SILVER	K1P1Y1	S
606	2A	*	A53-2101-08	CASSETTE LID(L) SILVER	M1M2M3	S
606	2A	*	A53-2101-08	CASSETTE LID(L) SILVER	Q1X1X2	S
606	2A	*	A53-2101-08	CASSETTE LID(L) SILVER	T1E1E2	S
607	2A	*	A53-2100-08	CASSETTE LID(R) BLACK	E3E4	B
607	2A	*	A53-2100-08	CASSETTE LID(R) BLACK	T2Q2X3	B
607	2A	*	A53-2102-08	CASSETTE LID(R) SILVER	K1P1Y1	S
607	2A	*	A53-2102-08	CASSETTE LID(R) SILVER	M1M2M3	S
607	2A	*	A53-2102-08	CASSETTE LID(R) SILVER	Q1X1X2	S
607	2A	*	A53-2102-08	CASSETTE LID(R) SILVER	T1E1E2	S
608	2B	*	A60-1570-08	FRONT PANEL BLACK	E4	B
608	2B	*	A60-1570-08	FRONT PANEL BLACK	T2Q2E3	B
608	2B	*	A60-1571-08	FRONT PANEL BLACK	X3	B
608	2B	*	A60-1572-08	FRONT PANEL SILVER	K1P1Y1	S
608	2B	*	A60-1572-08	FRONT PANEL SILVER	T1E1E2	S
608	2B	*	A60-1572-08	FRONT PANEL SILVER	X2M3Q1	S
608	2B	*	A60-1573-08	FRONT PANEL SILVER	M1X1M2	S
609	2A	*	A60-1576-08	PANEL(CD) BLACK	E3E4	B
609	2A	*	A60-1576-08	PANEL(CD) BLACK	X2Q2X3	B
609	2A	*	A60-1577-08	PANEL(CD) SILVER	E2X2M3	S
609	2A	*	A60-1577-08	PANEL(CD) SILVER	K1P1Y1	S
609	2A	*	A60-1577-08	PANEL(CD) SILVER	M1X1M2	S
609	2A	*	A60-1577-08	PANEL(CD) SILVER	T1E1Q1	S
610	1A	*	A70-1260-08	REMOTE CONTROLLER(RC-301)	S	
614	1C	*	B09-0262-08	LAMP CAP		
615	1C	*	B09-0263-08	LED COVER		
616	2A	*	B10-3450-08	FRONT GLASS(CASSETTE)L		

L : Scandinavia K : USA P : Canada R : Mexico C : China I : Malaysia
Y : PX(Far East, Hawaii) T : Europe E : Europe G : Germany V : China (Shanghai) B : BLACK S : SILVER H : GRAY
Y : AAFES(Europe) X : Australia Q : Russia H : Korea M : Other Areas Δ indicates safety critical components.

* New Parts

Parts without **Parts No.** are not supplied.
Les articles non mentionnés dans le **Parts No.** ne sont pas fournis.
Teile ohne **Parts No.** werden nicht geliefert.

②

Ref. No	Add-ress	New Parts	Parts No.	Description	Desti-nation	Re-marks
617	2A	*	B10-3451-08	FRONT GLASS(CASSETTE)R		
618	1B	*	B19-1602-08	LED LENS	E1E2E3	
618	1B	*	B19-1602-08	LED LENS	E4T1T2	
618	1B	*	B19-1602-08	LED LENS	M1M2M3	
618	1B	*	B19-1602-08	LED LENS	Q1Q2Y1	
618	1B	*	B19-1602-08	LED LENS	X1X2X3	
-	-	-	B46-0096-53	WARRANTY CARD	X1X2X3	
-	-	-	B46-0310-03	WARRANTY CARD	E1E2E3	
-	-	-	B46-0310-03	WARRANTY CARD	E4Q1Q2	
-	-	-	B46-0310-03	WARRANTY CARD	T1T2	
-	-	-	B46-0328-03	WARRANTY CARD	K1P1	
-	-	-	B46-0336-03	WARRANTY CARD	P1	
-	-	*	B60-3879-08	INSTRUCTION MANUAL(ENGLISH)	K1P1Y1	
-	-	*	B60-3879-08	INSTRUCTION MANUAL(ENGLISH)	M1X1T1	
-	-	*	B60-3879-08	INSTRUCTION MANUAL(ENGLISH)	M3X3E4	
-	-	*	B60-3879-08	INSTRUCTION MANUAL(ENGLISH)	Q1E2M2	
-	-	*	B60-3879-08	INSTRUCTION MANUAL(ENGLISH)	T2Q2X2	
-	-	*	B60-3880-08	INSTRUCTION MANUAL(FRENCH)	P1E1E3	
-	-	*	B60-3881-08	INSTRUCTION MANUAL(GERMAN)	E1E3	
-	-	*	B60-3882-08	INSTRUCTION MANUAL(DUTCH)	E1E3	
-	-	*	B60-3883-08	INSTRUCTION MANUAL(ITALIAN)	E1E3	
-	-	*	B60-3884-08	INSTRUCTION MANUAL(SPANISH)	E1M1M2	
-	-	*	B60-3884-08	INSTRUCTION MANUAL(SPANISH)	E3M3	
-	-	*	B60-3885-08	INSTRUCTION MANUAL(PH)	E2E4	
-	-	*	B60-3886-08	INSTRUCTION MANUAL(HG)	E2E4	
-	-	*	B60-3887-08	INSTRUCTION MANUAL(CZ)	E2E4	
-	-	*	B60-3888-08	INSTRUCTION MANUAL(R)	Q1Q2	
-	-	*	B60-3889-08	INSTRUCTION MANUAL(TAIWANESE)	M1M2	
621	2B	*	D16-0725-08	F BELT(CASSETTE)		
622	2B,2C	*	D16-0726-08	M BELT(CASSETTE)		
623	1B	*	D16-0727-08	LOADING BELT(CD)		
624	1B	*	D16-0728-08	LOADING GEAR BELT(CD)		
625	2A,2B	*	D39-0325-08	GEAR DAMPER		
626	2B	*	D40-1621-08	CASSETTE MECHANISM ASSY		
627	1B	*	D40-1622-08	CD MECHANISM ASSY		
Δ 631	1A	*	E03-0115-05	AC PLUG ADAPTER	M1M2M3	
Δ 632	1C	*	E30-2895-08	AC POWER CORD	K1P1	
Δ 632	1C	*	E30-2905-08	AC POWER CORD	T1T2	
Δ 632	1C	*	E30-2906-08	AC POWER CORD	M1E1Q1	
Δ 632	1C	*	E30-2906-08	AC POWER CORD	M2E2Q2	
Δ 632	1C	*	E30-2906-08	AC POWER CORD	M3E3E4	
Δ 632	1C	*	E30-2907-08	AC POWER CORD	Y1	
Δ 632	1C	*	E30-2908-08	AC POWER CORD	X1X2X3	
633	1B,1C	*	E35-2288-08	FLAT CABLE(18P)		
636	2A	*	G01-4106-08	EJECT SPRING		
637	2A	*	G11-2432-08	CUSHION(FOOT RUBBER)		
-	-	*	H10-7538-08	POLYSTYRENE FOAMED FIXTURE(L)		
-	-	*	H10-7539-08	POLYSTYRENE FOAMED FIXTURE(R)		
-	-	*	H21-0366-08	SOFT SHEET(1500X700X0.5)		
-	-	*	H25-1527-08	POLY BAG		
-	-	*	H50-2988-08	ITEM CARTON CASE	T2E3	
-	-	*	H50-2989-08	ITEM CARTON CASE	E4	
-	-	*	H50-2990-08	ITEM CARTON CASE	Q2	

L : Scandinavia K : USA P : Canada R : Mexico C : China I : Malaysia
Y : PX(Far East, Hawaii) T : Europe E : Europe G : Germany V : China (Shanghai) B : BLACK S : SILVER H : GRAY
Y : AAFES(Europe) X : Australia Q : Russia H : Korea M : Other Areas Δ indicates safety critical components.

PARTS LIST

RXD-251/301/351/371S/A3

* New Parts
Parts without **Parts No.** are not supplied.
Les articles non mentionnés dans le **Parts No.** ne sont pas fournis.
Teile ohne **Parts No.** werden nicht geliefert.



Ref. No	Add-ress	New Parts	Parts No.	Description	Desti-nation	Re-marks
-		*	H50-2992-08	ITEM CARTON CASE	T1E1	
-		*	H50-2993-08	ITEM CARTON CASE	E2	
-		*	H50-2994-08	ITEM CARTON CASE	Q1	
-		*	H50-2995-08	ITEM CARTON CASE	M1	
-		*	H50-2996-08	ITEM CARTON CASE	M2	
-		*	H50-3001-08	ITEM CARTON CASE	M3	
-		*	H60-0685-08	ITEM CARTON CASE	K1P1	
-		*	H60-0686-08	ITEM CARTON CASE	X3	
-		*	H60-0687-08	ITEM CARTON CASE	X1Y1	
-		*	H60-0771-08	ITEM CARTON CASE	X2	
640	2C	*	J19-5961-08	UNIT HOLDER	E1E2E3	
640	2C	*	J19-5961-08	UNIT HOLDER	E4Q1Q2	
640	2C	*	J19-5961-08	UNIT HOLDER	T1T2	
641	2C	*	J02-1433-08	FOOT(REAR)	E1E2E3	
641	2C	*	J02-1433-08	FOOT(REAR)	M1M2E4	
641	2C	*	J02-1433-08	FOOT(REAR)	Q1Q2X1	
641	2C	*	J02-1433-08	FOOT(REAR)	T1T2Y1	
641	2C	*	J02-1434-08	FOOT(REAR)	K1P1X2	
641	2C	*	J02-1434-08	FOOT(REAR)	M3X3	
Δ 642	1C	*	J42-0330-08	POWER CORD BUSHING	E1E2E3	
Δ 642	1C	*	J42-0330-08	POWER CORD BUSHING	E4Q1Q2	
Δ 642	1C	*	J42-0330-08	POWER CORD BUSHING	M1M2Y1	
Δ 642	1C	*	J42-0330-08	POWER CORD BUSHING	T1T2X1	
646	2B	*	K29-7487-08	CASSETTE RECORD BUTTON(A)	E3E4	B
646	2B	*	K29-7487-08	CASSETTE RECORD BUTTON(A)	T2Q2X3	B
646	2B	*	K29-7498-08	CASSETTE RECORD BUTTON(A)	K1P1Y1	H
646	2B	*	K29-7498-08	CASSETTE RECORD BUTTON(A)	M1M2M3	H
646	2B	*	K29-7498-08	CASSETTE RECORD BUTTON(A)	T1E1E2	H
646	2B	*	K29-7498-08	CASSETTE RECORD BUTTON(A)	X1X2Q1	H
647	2B	*	K29-7488-08	CASSETTE PLAY BUTTON(A)	E3E4	B
647	2B	*	K29-7488-08	CASSETTE PLAY BUTTON(A)	T2Q2X3	B
647	2B	*	K29-7499-08	CASSETTE PLAY BUTTON(A)	K1P1Y1	H
647	2B	*	K29-7499-08	CASSETTE PLAY BUTTON(A)	M1M2M3	H
647	2B	*	K29-7499-08	CASSETTE PLAY BUTTON(A)	T1E1E2	H
647	2B	*	K29-7499-08	CASSETTE PLAY BUTTON(A)	X1X2Q1	H
648	2B	*	K29-7489-08	CASSETTE REWIND BUTTON(A)	E3E4	B
648	2B	*	K29-7489-08	CASSETTE REWIND BUTTON(A)	T2Q2X3	B
648	2B	*	K29-7500-08	CASSETTE REWIND BUTTON(A)	K1P1Y1	H
648	2B	*	K29-7500-08	CASSETTE REWIND BUTTON(A)	M1M2M3	H
648	2B	*	K29-7500-08	CASSETTE REWIND BUTTON(A)	T1E1E2	H
648	2B	*	K29-7500-08	CASSETTE REWIND BUTTON(A)	X1X2Q1	H
649	2B	*	K29-7490-08	CASSETTE FASTFORWARD BUTTON(A)	E3E4	B
649	2B	*	K29-7490-08	CASSETTE FASTFORWARD BUTTON(A)	T2Q2X3	B
649	2B	*	K29-7501-08	CASSETTE FASTFORWARD BUTTON(A)	K1P1Y1	H
649	2B	*	K29-7501-08	CASSETTE FASTFORWARD BUTTON(A)	M1M2M3	H
649	2B	*	K29-7501-08	CASSETTE FASTFORWARD BUTTON(A)	T1E1E2	H
649	2B	*	K29-7501-08	CASSETTE FASTFORWARD BUTTON(A)	X1X2Q1	H
650	2B	*	K29-7491-08	CASSETTE STOP/EJECT BUTTON(A)	E3E4	B
650	2B	*	K29-7491-08	CASSETTE STOP/EJECT BUTTON(A)	T2Q2X3	B
650	2B	*	K29-7502-08	CASSETTE STOP/EJECT BUTTON(A)	K1P1Y1	H
650	2B	*	K29-7502-08	CASSETTE STOP/EJECT BUTTON(A)	M1M2M3	H
650	2B	*	K29-7502-08	CASSETTE STOP/EJECT BUTTON(A)	T1E1E2	H
650	2B	*	K29-7502-08	CASSETTE STOP/EJECT BUTTON(A)	X1X2Q1	H
651	2B	*	K29-7492-08	CASSETTE PAUSE BUTTON(A)	E3E4	B

L : Scandinavia K : USA P : Canada R : Mexico C : China I : Malaysia
Y : PX(Far East, Hawaii) T : Europe E : Europe G : Germany V : China (Shanghai) B : BLACK S : SILVER H : GRAY
Y : AAFES(Europe) X : Australia Q : Russia H : Korea M : Other Areas Δ indicates safety critical components.

* New Parts
Parts without **Parts No.** are not supplied.
Les articles non mentionnés dans le **Parts No.** ne sont pas fournis.
Teile ohne **Parts No.** werden nicht geliefert.



Ref. No	Add-ress	New Parts	Parts No.	Description	Desti-nation	Re-marks
651	2B	*	K29-7492-08	CASSETTE PAUSE BUTTON(A)	T2Q2X3	B
651	2B	*	K29-7503-08	CASSETTE PAUSE BUTTON(A)	K1P1Y1	H
651	2B	*	K29-7503-08	CASSETTE PAUSE BUTTON(A)	M1M2M3	H
651	2B	*	K29-7503-08	CASSETTE PAUSE BUTTON(A)	T1E1E2	H
651	2B	*	K29-7503-08	CASSETTE PAUSE BUTTON(A)	X1X2Q1	H
652	2B	*	K29-7493-08	CASSETTE PLAY BUTTON(B)	E3E4	B
652	2B	*	K29-7493-08	CASSETTE PLAY BUTTON(B)	T2Q2X3	B
652	2B	*	K29-7504-08	CASSETTE PLAY BUTTON(B)	K1P1Y1	H
652	2B	*	K29-7504-08	CASSETTE PLAY BUTTON(B)	M1M2M3	H
652	2B	*	K29-7504-08	CASSETTE PLAY BUTTON(B)	T1E1E2	H
652	2B	*	K29-7504-08	CASSETTE PLAY BUTTON(B)	X1X2Q1	H
653	2B	*	K29-7494-08	CASSETTE REWIND BUTTON(B)	E3E4	B
653	2B	*	K29-7494-08	CASSETTE REWIND BUTTON(B)	T2Q2X3	B
653	2B	*	K29-7505-08	CASSETTE REWIND BUTTON(B)	K1P1Y1	H
653	2B	*	K29-7505-08	CASSETTE REWIND BUTTON(B)	M1M2M3	H
653	2B	*	K29-7505-08	CASSETTE REWIND BUTTON(B)	T1E1E2	H
653	2B	*	K29-7505-08	CASSETTE REWIND BUTTON(B)	X1X2Q1	H
654	2B	*	K29-7495-08	CASSETTE FASTFORWARD BUTTON(B)	E3E4	B
654	2B	*	K29-7495-08	CASSETTE FASTFORWARD BUTTON(B)	T2Q2X3	B
654	2B	*	K29-7506-08	CASSETTE FASTFORWARD BUTTON(B)	K1P1Y1	H
654	2B	*	K29-7506-08	CASSETTE FASTFORWARD BUTTON(B)	M1M2M3	H
654	2B	*	K29-7506-08	CASSETTE FASTFORWARD BUTTON(B)	T1E1E2	H
654	2B	*	K29-7506-08	CASSETTE FASTFORWARD BUTTON(B)	X1X2Q1	H
655	2B	*	K29-7496-08	CASSETTE STOP/EJECT BUTTON(B)	E3E4	B
655	2B	*	K29-7496-08	CASSETTE STOP/EJECT BUTTON(B)	T2Q2X3	B
655	2B	*	K29-7507-08	CASSETTE STOP/EJECT BUTTON(B)	K1P1Y1	H
655	2B	*	K29-7507-08	CASSETTE STOP/EJECT BUTTON(B)	M1M2M3	H
655	2B	*	K29-7507-08	CASSETTE STOP/EJECT BUTTON(B)	T1E1E2	H
655	2B	*	K29-7507-08	CASSETTE STOP/EJECT BUTTON(B)	X1X2Q1	H
656	2B	*	K29-7497-08	CASSETTE PAUSE BUTTON(B)	E3E4	B
656	2B	*	K29-7497-08	CASSETTE PAUSE BUTTON(B)	T2Q2X3	B
656	2B	*	K29-7508-08	CASSETTE PAUSE BUTTON(B)	K1P1Y1	H
656	2B	*	K29-7508-08	CASSETTE PAUSE BUTTON(B)	M1M2M3	H
656	2B	*	K29-7508-08	CASSETTE PAUSE BUTTON(B)	T1E1E2	H
656	2B	*	K29-7508-08	CASSETTE PAUSE BUTTON(B)	X1X2Q1	H
657	1B	*	K29-7509-08	KNOB(MIC)	M1X1M2	H
657	1B	*	K29-7509-08	KNOB(MIC)	X3	H
658	1B	*	K29-7511-08	KNOB(DISPLAY/DEMO)		
659	2B	*	K29-7519-08	KNOB(BAND)		
660	1B	*	K29-7512-08	KNOB(EX.BASS)		
661	1A	*	K29-7513-08	KNOB(ROCK)		
662	1A	*	K29-7514-08	KNOB(BASE ROCK)		
663	1A	*	K29-7515-08	KNOB(POP)		
664	1A	*	K29-7516-08	KNOB(JAZZ)		
665	1A	*	K29-7517-08	KNOB(BASE JAZZ)		
666	2B	*	K29-7518-08	KNOB(FLAT)		
667	1B	*	K29-7520-08	KNOB(ON/STANDBY.INPUT)	E3E4	B
667	1B	*	K29-7520-08	KNOB(ON/STANDBY.INPUT)	T2Q2X3	B
667	1B	*	K29-7549-08	KNOB(ON/STANDBY.INPUT)	E1E2T1	H
667	1B	*	K29-7549-08	KNOB(ON/STANDBY.INPUT)	M1M2M3	H
667	1B	*	K29-7549-08	KNOB(ON/STANDBY.INPUT)	X1X2Q1	H
667	1B	*	K29-7549-08	KNOB(ON/STANDBY.INPUT)	Y1	H
667	1B	*	K29-7550-08	KNOB(POWER INPUT)	K1P1	H
668	1B	*	K29-7521-08	KNOB(DISC 1)		
669	1B	*	K29-7522-08	KNOB(DISC 2)		

L : Scandinavia K : USA P : Canada R : Mexico C : China I : Malaysia
Y : PX(Far East, Hawaii) T : Europe E : Europe G : Germany V : China (Shanghai) B : BLACK S : SILVER H : GRAY
Y : AAFES(Europe) X : Australia Q : Russia H : Korea M : Other Areas Δ indicates safety critical components.

PARTS LIST

RXD-251/301/351/371S/A3

* New Parts

Parts without **Parts No.** are not supplied.
Les articles non mentionnés dans le **Parts No.** ne sont pas fournis.
Teile ohne **Parts No.** werden nicht geliefert.

7

Ref. No	Add-ress	New Parts	Parts No.	Description	Desti-nation	Re-marks
C151,152			C91-0759-05	CERAMIC 1500PF M		
C153			C91-0085-05	CERAMIC 0.022UF N		
C155			C91-0745-05	CERAMIC 100PF K		
C157			C91-0757-05	CERAMIC 1000PF K		
C160			C91-0085-05	CERAMIC 0.022UF N		
C161,162			CE04KW1H010M	ELECTRO 1.0UF 50WV		
C164			CK45FB1H103Z	CERAMIC 0.010UF Z	M2	
C164			CQ93FMG1H682J	MYLAR 6800PF J	M1M2M3	
C164			CQ93FMG1H682J	MYLAR 6800PF J	Y1	
C165			CK45FB1H223Z	CERAMIC 0.022UF Z	M2	
C165			CQ93FMG1H682J	MYLAR 6800PF J	K1P1Y1	
C165			CQ93FMG1H682J	MYLAR 6800PF J	M1X1X2	
C165			CQ93FMG1H682J	MYLAR 6800PF J	M3X3	
C166			CK45FB1H223Z	CERAMIC 0.022UF Z	M2	
C167			CQ93FMG1H471J	MYLAR 470PF J	M2	
C169			C91-0085-05	CERAMIC 0.022UF N	M2	
C170			C91-0769-05	CERAMIC 0.010UF K	M2	
C171			CK45FB1H104Z	CERAMIC 0.10UF Z	K1P1Y1	
C171			CK45FB1H104Z	CERAMIC 0.10UF Z	M1X1X2	
C171			CK45FB1H104Z	CERAMIC 0.10UF Z	M3X3	
C171			CK45FB1H223Z	CERAMIC 0.022UF Z	M2	
C174,175			CQ92FM1H682J	MYLAR 6800PF J	M2	
C201			CK45FB1H561K	CERAMIC 560PF K	M2	
C202			CQ09S1H472J	POLYSTY 4700PF J	M2	
C204			C91-0085-05	CERAMIC 0.022UF N	M2	
C205			CE04KW1C470M	ELECTRO 47UF 16WV	M2	
C207			CE04KW1C470M	ELECTRO 47UF 16WV		
C208			C91-0769-05	CERAMIC 0.010UF K		
C209			C91-0745-05	CERAMIC 100PF K		
C210-212			C91-0745-05	CERAMIC 100PF K		
C212			C91-0085-05	CERAMIC 0.022UF N	M2	
C213,214			CC45FCH1H240J	CERAMIC 24PF J	K1P1Y1	
C213,214			CC45FCH1H240J	CERAMIC 24PF J	M1X1X2	
C213,214			CC45FCH1H240J	CERAMIC 24PF J	M3X3	
C213,214			CC45FCH1H270J	CERAMIC 27PF J	M2	
C215			CE04KW1C220M	ELECTRO 22UF 16WV		
C216			C91-0085-05	CERAMIC 0.022UF N	M2	
C217			C91-0085-05	CERAMIC 0.022UF N	M2	
C220			C91-0749-05	CERAMIC 220PF K		
C221-223			C91-0749-05	CERAMIC 220PF K	K1P1Y1	
C221-223			C91-0749-05	CERAMIC 220PF K	M1X1X2	
C221-223			C91-0749-05	CERAMIC 220PF K	M3X3	
TC101,102		*	C05-0238-08	TRIMMER CON 10PS TZ-03N100TR		
TC201		*	C05-0238-08	TRIMMER CON 10PS TZ-03N100TR	M2	
CN101		*	E40-8336-08	PIN ASSY (10P)		
JK101			E70-0070-08	ANTENNA TERMINAL (4P)		
CF101			L72-0591-08	CERAMIC F SFE10.7MA5 RED		
CF102			L72-0586-08	CERAMIC F SFE10.7MSG3GYM RED		
CF103			L72-0587-08	CERAMIC F SFZ450B		
CF104			L78-0651-08	RESONATOR CDA10.7MG43-A		
CF105			L78-0641-08	RESONATOR CSB456F15		
L101			L31-0622-08	FM ANT COIL PC-8474-1		
L102			L31-0623-08	FM RF COIL PC-8867		
L103			L32-0584-08	FM OSC COIL R22-F036X ORG		

L: Scandinavia K: USA P: Canada R: Mexico C: China I: Malaysia
Y: PX(Far East, Hawaii) T: Europe E: Europe G: Germany V: China (Shanghai) B: BLACK S: SILVER H: GRAY
Y: AAFES(Europe) X: Australia Q: Russia H: Korea M: Other Areas Δ indicates safety critical components.

* New Parts

Parts without **Parts No.** are not supplied.
Les articles non mentionnés dans le **Parts No.** ne sont pas fournis.
Teile ohne **Parts No.** werden nicht geliefert.

8

Ref. No	Add-ress	New Parts	Parts No.	Description	Desti-nation	Re-marks
L104			L31-0618-08	AM ANT COIL TWS-358-762		
L105			L32-0581-08	MW OSC COIL TWS-358-751		
L106			L39-1340-08	INDUCTANCE 473K	M2	
L107,108			L39-1340-08	INDUCTANCE 473K		
L201		*	L31-0634-08	SW ANT COIL	M2	
L202		*	L32-1005-08	SW OSC COIL	M2	
L203			L39-1344-08	P. COIL 470K-T		
L204			L39-1340-08	INDUCTANCE 473K	M2	
L205			L39-1344-08	P. COIL 470K-T	M2	
T101			L30-0926-08	FM IFT TWS-358-412		
T102			L30-0922-08	AM IFT R22-E792		
X201		*	L77-2243-08	X' TAL(7.2MHZ)		
R130			RS14GB2H101J	FL-PROOF RS 100 J 1/2W	M2	
R130		*	RD14GB2H151J	RD 150 J 1/2W	K1P1Y1	
R130		*	RD14GB2H151J	RD 150 J 1/2W	M1X1X2	
R130		*	RD14GB2H151J	RD 150 J 1/2W	M3X3	
D101,102			1SS133T	DIODE		
D105			1SS133T	DIODE		
D106		*	KV1340A-2	DIODE		
D108		*	KV1561A-2	DIODE		
D110			MTZ5.6B	ZENER DIODE	K1P1Y1	
D110			MTZ5.6B	ZENER DIODE	M1X1X2	
D110			MTZ5.6B	ZENER DIODE	M3X3	
D110			MTZ6.2B	ZENER DIODE	M2	
D111,112			1SS133T	DIODE	K1P1Y1	
D111,112			1SS133T	DIODE	M1X1X2	
D111,112			1SS133T	DIODE	M3X3	
D202			1SS133T	DIODE		
IC101			LA1186N	IC		
IC102			LA1831	IC(AM/FM TUNER)		
IC201			LC7218	IC(PLL FREQUENCY SYNTHESIZER)		
Q100			2SC2001L	TRANSISTOR	M2	
Q101			2SC1675(L)	TRANSISTOR		
Q102			2SC1674(L)	TRANSISTOR		
Q105			DTA114YS	TRANSISTOR		
Q106		*	2SK544F-T	FET		
Q107,108			2SC945	TRANSISTOR		
Q109			DTC114YS	TRANSISTOR		
Q110-111			DTC114YS	TRANSISTOR	M1Y1M3	
Q110-111			2SC2878A	TRANSISTOR	M2	
Q112			2SC2878A	TRANSISTOR	M2	
Q113			DTA144ES	TRANSISTOR	M2	
Q114			2SC2001L	TRANSISTOR	M2	
Q115,116			DTC114YS	TRANSISTOR	M2	
Q201			DTA144ES	TRANSISTOR	M2	
Q202,203			2SC2878A	TRANSISTOR	M2	
TUNER UNIT (E1T1Q1E2T2Q2E3E4)						
FE101		*	W02-2681-08	FM FRONT END	E1E2E3	
FE101		*	W02-2681-08	FM FRONT END	E4T1T2	
FE101		*	W02-2682-08	FM FRONT END	Q1Q2	
C101			CE04KW1C101M	ELECTRO 100UF 16WV		
C102			CK45FB1H102K	CERAMIC 1000PF K		
C103			CK45FB1H104K	CERAMIC 0.10UF K		
C106,107			CK45FB1E223Z	CERAMIC 0.022UF Z		

L: Scandinavia K: USA P: Canada R: Mexico C: China I: Malaysia
Y: PX(Far East, Hawaii) T: Europe E: Europe G: Germany V: China (Shanghai) B: BLACK S: SILVER H: GRAY
Y: AAFES(Europe) X: Australia Q: Russia H: Korea M: Other Areas Δ indicates safety critical components.

PARTS LIST

RXD-251/301/351/371S/A3

* New Parts
Parts without **Parts No.** are not supplied.
Les articles non mentionnés dans le **Parts No.** ne sont pas fournis.
Teile ohne **Parts No.** werden nicht geliefert.

9

Ref. No	Add-ress	New Parts	Parts No.	Description	Desti-nation	Re-marks
C108			CK45FB1C103K	CERAMIC 0.010UF K		
C111,112			CK45FB1C152K	CERAMIC 1500PF K		
C114			CK45FB1H104Z	CERAMIC 0.10UF Z		
C116			CQ93FMG1H471J	MYLAR 470PF J		
C117			CC45FSL1H200J	CERAMIC 20PF J		
C118			CE04KW1C101M	ELECTRO 100UF 16WV		
C121			CC45FSL1H150J	CERAMIC 15PF J		
C122			CE04KW1H2R2M	ELECTRO 2.2UF 50WV		
C123			CE04KW1H010M	ELECTRO 1.0UF 50WV		
C124			CC45FSL1H200J	CERAMIC 20PF J		
C125			CE04KW1H010M	ELECTRO 1.0UF 50WV		
C126			CK45FB1H473Z	CERAMIC 0.047UF Z		
C127			CE04KW1H100M	ELECTRO 10UF 50WV		
C128			CK45FB1E223Z	CERAMIC 0.022UF Z		
C129			CE04KW1H010M	ELECTRO 1.0UF 50WV		
C130,131			CQ92FM1H153J	MYLAR 0.015UF J		
C132,133			CQ92FM1H102J	MYLAR 1000PF J		
C135			CE04KW1H3R3M	ELECTRO 3.3UF 50WV		
C137			CE04KW1HR47M	ELECTRO 0.47UF 50WV		
C138			CK45FB1C103K	CERAMIC 0.010UF K		
C139			CK45FB1E223Z	CERAMIC 0.022UF Z		
C140			CE04KW1C101M	ELECTRO 100UF 16WV		
C141			CK45FB1E223Z	CERAMIC 0.022UF Z		
C142			CE04KW1C101M	ELECTRO 100UF 16WV		
C143			CE04KW1HR47M	ELECTRO 0.47UF 50WV		
C144			CK45FB1E223Z	CERAMIC 0.022UF Z		
C145			CC45FSL1H560J	CERAMIC 56PF J		
C147			CK45FB1E223Z	CERAMIC 0.022UF Z		
C148			CK45FB1H104Z	CERAMIC 0.10UF Z		
C149			CK45FB1E223Z	CERAMIC 0.022UF Z		
C150			CK45FB1H104Z	CERAMIC 0.10UF Z		
C151			CK45FB1H181K	CERAMIC 180PF K		
C152			CK45FB1E122K	CERAMIC 1200PF K		
C153			CK45FB1E223Z	CERAMIC 0.022UF Z		
C154			CK45FB1C103K	CERAMIC 0.010UF K		
C156			CC45FCH1H100J	CERAMIC 10PF J		
C157			CK45FB1H102K	CERAMIC 1000PF K		
C160			CK45FB1E223Z	CERAMIC 0.022UF Z		
C161,162			CE04KW1H010M	ELECTRO 1.0UF 50WV		
C201,202			CK45FB1E223Z	CERAMIC 0.022UF Z	T1T2	
C203			CQ93FMG1H181J	MYLAR 180PF J	T1T2	
C204			CC45FCH1H100J	CERAMIC 10PF J	T1T2	
C205			CK45FB1E223Z	CERAMIC 0.022UF Z	T1T2	
C206			CC45FCH1H100J	CERAMIC 10PF J	T1T2	
C207			CE04KW1C470M	ELECTRO 47UF 16WV		
C208			CK45FB1C103K	CERAMIC 0.010UF K		
C209-212			CK45FB1H101K	CERAMIC 100PF K		
C213,214			CC45FSL1H240J	CERAMIC 24PF J		
C215			CE04KW1C220M	ELECTRO 22UF 16WV		
C220			CK45FB1H221K	CERAMIC 220PF K		
TC102		*	C05-0238-08	TRIMMER 10P		
TC201,202		*	C05-0239-08	TRIMMER 30P	T1T2	
CN101		*	E40-8336-08	PIN ASSY(10P)		
JK101		*	E20-0321-05	ANTENNA TERMINAL(3P)		

L : Scandinavia K : USA P : Canada R : Mexico C : China I : Malaysia
Y : PX(Far East, Hawaii) T : Europe E : Europe G : Germany V : China (Shanghai) B : BLACK S : SILVER H : GRAY
Y : AAFES(Europe) X : Australia Q : Russia H : Korea M : Other Areas Δ indicates safety critical components.

* New Parts
Parts without **Parts No.** are not supplied.
Les articles non mentionnés dans le **Parts No.** ne sont pas fournis.
Teile ohne **Parts No.** werden nicht geliefert.

10

Ref. No	Add-ress	New Parts	Parts No.	Description	Desti-nation	Re-marks
TP1 ,2			E40-8111-08	40P PIN HEADER		
CF103			L72-0587-08	CERAMIC F		
CF104			L78-0651-08	RESONATOR		
CF105			L78-0641-08	RESONATOR		
L102,103			L39-1334-08	COIL		
L104			L31-0618-08	AM ANT COIL		
L105			L32-0581-08	MW OSC COIL		
L106			L39-1334-08	COIL		
L107,108			L39-1340-08	INDUCTANCE		
L110			L39-1332-08	COIL		
L201		*	L31-0635-08	ANT COIL		T1T2
L202			L32-0581-08	COIL(CHOKE) 470UH		E1E2E3
L202			L32-0581-08	COIL(CHOKE) 470UH		E4Q1Q2
L202		*	L32-1008-08	OSC COIL		T1T2
L203			L39-1344-08	COIL		
SF101,102		*	L72-0615-08	C.FILTER		
T101			L79-1229-08	FTZ L.P.F		
T102			L30-0922-08	AM IFT		
X201		*	L77-2243-08	CRYSTAL		
R103		*	RD14GB2H330J	RD 33 J 1/2W		Q1Q2
R103		*	RD14GB2H680J	RD 68 J 1/2W		E1E2E3
R103		*	RD14GB2H680J	RD 68 J 1/2W		E4T1T2
R130		*	RD14GB2H151J	RD 150 J 1/2W		
D101,102			1SS133T-77	DIODE		
D108		*	KV1561A-2	DIODE		
D110			MTZ5.6B	ZENER DIODE		
D111,112			1SS133T-77	DIODE		
D201			1SS133T-77	DIODE		T1T2
D202			1SS133T-77	DIODE		
IC102			LA1831A-KEN	IC(AM/FM/MPX SYSTEM IC)		
IC201			LC7218	IC(PLL FREQUENCY SYNTHESIZER)		
Q101			2SC1675(L)	TRANSISTOR		
Q105			DTA114YS	TRANSISTOR		
Q106		*	2SK544F-T	TRANSISTOR		
Q107,108			2SC945	TRANSISTOR		
Q109			DTC114YS	TRANSISTOR		
Q201			2SA733	TRANSISTOR		T1T2
Q202			2SC945	TRANSISTOR		T1T2
Q203,204			2SC2001(L)	TRANSISTOR		T1T2
Q205			2SC945	TRANSISTOR		T1T2
AUDIO UNIT						
C201,202			CK45FB1H221K	CERAMIC 220PF K		
C203,204			CK45FB1H681K	CERAMIC 680PF K		
C205,206			CK45FB1H221K	CERAMIC 220PF K		
C207,208			CE04KW1C470M	ELECTRO 47UF 16WV		
C209,210			CQ92FM1H103J	MYLAR 0.010UF J		
C211,212			CE04KW1H1R0M	ELECTRO 1.0UF 50WV		
C213,214			CK45FB1C152K	CERAMIC 1500PF K		
C215,216			C91-0758-05	CERAMIC 1200PF M		
C217,218			CK45FB1H221K	CERAMIC 220PF K		
C219,220			CE04KW1H3R3M	ELECTRO 3.3UF 50WV		
C221,222			CE04KW1C470M	ELECTRO 47UF 16WV		
C223,224			CK45FB1H102K	CERAMIC 1000PF K		

L : Scandinavia K : USA P : Canada R : Mexico C : China I : Malaysia
Y : PX(Far East, Hawaii) T : Europe E : Europe G : Germany V : China (Shanghai) B : BLACK S : SILVER H : GRAY
Y : AAFES(Europe) X : Australia Q : Russia H : Korea M : Other Areas Δ indicates safety critical components.

* New Parts

Parts without **Parts No.** are not supplied.
Les articles non mentionnés dans le **Parts No.** ne sont pas fournis.
Teile ohne **Parts No.** werden nicht geliefert.

11

Ref. No	Add-ress	New Parts	Parts No.	Description	Desti-nation	Re-marks
C225			CE04KW1H3R3M	ELECTRO 3.3UF 50WV		
C226			CE04KW1H3R3M	ELECTRO 3.3UF 50WV		
C227			CE04KW1C470M	ELECTRO 47UF 16WV		
C228			CE04KW1H100M	ELECTRO 10UF 50WV		
C230			CQ93FMG2A153J	MYLAR 0.015UF J		
C231			CQ92FM1H103J	MYLAR 0.010UF J		
C232			CQ92FM1H472J	MYLAR 4700PF J		
C233			CQ92FM1H223J	MYLAR 0.022UF J		
C234			CE04KW1C470M	ELECTRO 47UF 16WV		
C235			CK45FB1E223Z	CERAMIC 0.022UF Z		
C236			CE04KW1C221M	ELECTRO 220UF 16WV		
C237			CE04KW1C331M	ELECTRO 330UF 16WV		
C238			CE04KW1H3R3M	ELECTRO 3.3UF 50WV		
C239,240			CK45FB1H681K	CERAMIC 680PF K		
C241			CE04KW1A101M	ELECTRO 100UF 10WV		
C242			CE04KW1HR47M	ELECTRO 0.47UF 50WV	E1E2E3	
C242			CE04KW1HR47M	ELECTRO 0.47UF 50WV	E4T1T2	
C242			CE04KW1HR47M	ELECTRO 0.47UF 50WV	M1M2X1	
C242			CE04KW1HR47M	ELECTRO 0.47UF 50WV	Q1Q2X3	
C243			CE04KW1H2R2M	ELECTRO 2.2UF 50WV		
C244			CK45FB1E223Z	CERAMIC 0.022UF Z		
C245		*	CQ93FMG2A332J	MYLAR 3300PF J		
C246			CK45FB1E223Z	CERAMIC 0.022UF Z		
C301,302			CE04KW1HR22M	ELECTRO 0.22UF 50WV	M1M2X1	
C301,302			CE04KW1HR22M	ELECTRO 0.22UF 50WV	X3	
C305			CE04KW1H4R7M	ELECTRO 4.7UF 50WV	M1M2X1	
C305			CE04KW1H4R7M	ELECTRO 4.7UF 50WV	X3	
C306			CE04KW1H100M	ELECTRO 10UF 50WV	M1M2X1	
C306			CE04KW1H100M	ELECTRO 10UF 50WV	X3	
C307			CE04KW1C100M	ELECTRO 10UF 16WV	M1M2X1	
C307			CE04KW1C100M	ELECTRO 10UF 16WV	X3	
C308			CE04KW1HR22M	ELECTRO 0.22UF 50WV	M1M2X1	
C308			CE04KW1HR22M	ELECTRO 0.22UF 50WV	X3	
C309			CE04KW1H100M	ELECTRO 10UF 50WV	M1M2X1	
C309			CE04KW1H100M	ELECTRO 10UF 50WV	X3	
C311			CE04KW1C221M	ELECTRO 220UF 16WV	M1M2X1	
C311			CE04KW1C221M	ELECTRO 220UF 16WV	X3	
C313,314			CE04KW1HR47M	ELECTRO 0.47UF 50WV	M1M2X1	
C313,314			CE04KW1HR47M	ELECTRO 0.47UF 50WV	X3	
C315			CE04KW1H471M	ELECTRO 470UF 50WV	M1M2X1	
C316			CE04KW1H010M	ELECTRO 1.0UF 50WV	X3	
C317			CK45FB1H104Z	CERAMIC 0.10UF Z	M1M2X1	
C317			CK45FB1H104Z	CERAMIC 0.10UF Z	X3	
C319			CK45FB1H392K	CERAMIC 3900PF K	M1M2X1	
C319			CK45FB1H392K	CERAMIC 3900PF K	X3	
C320			CE04KW1H010M	ELECTRO 1.0UF 50WV	M1M2X1	
C320			CE04KW1H010M	ELECTRO 1.0UF 50WV	X3	
C321			CK45FB1E472K	CERAMIC 4700PF K	M1M2X1	
C321			CK45FB1E472K	CERAMIC 4700PF K	X3	
C401,402			CK45FB1H331K	CERAMIC 330PF K		
C403,404			CK45FB1H471K	CERAMIC 470PF K		
C405			C91-1525-08	CERAMIC 0.1UF Z		
C406,407			CE04KW1H4R7M	ELECTRO 4.7UF 50WV		
C408-413			CE04KW1HR47M	ELECTRO 0.47UF 50WV		
C414,415			CC45FSL1H100J	CERAMIC 10PF J		

L : Scandinavia K : USA P : Canada R : Mexico C : China I : Malaysia
Y : PX(Far East, Hawaii) T : Europe E : Europe G : Germany V : China (Shanghai) B : BLACK S : SILVER H : GRAY
Y : AAFES(Europe) X : Australia Q : Russia H : Korea M : Other Areas Δ indicates safety critical components.

* New Parts

Parts without **Parts No.** are not supplied.
Les articles non mentionnés dans le **Parts No.** ne sont pas fournis.
Teile ohne **Parts No.** werden nicht geliefert.

12

Ref. No	Add-ress	New Parts	Parts No.	Description	Desti-nation	Re-marks
C416,417			CK45FB1H471K	CERAMIC 470PF K		
C418,419			CQ92FM1H562J	MYLAR 5600PF J		
C420,421			CK45FB1H471K	CERAMIC 470PF K		
C422,423			CK45FB1H102K	CERAMIC 1000PF K		
C424			CE04KW1HR47M	ELECTRO 0.47UF 50WV	K1P1Y1	
C424			CE04KW1HR47M	ELECTRO 0.47UF 50WV	M3X2	
C426,427			CK45FB1C152K	CERAMIC 1500PF K		
C428,429			CQ92FM1H183J	MYLAR 0.018UF J		
C430,431			CK45FB1H681K	CERAMIC 680PF K		
C432,433			C91-0767-05	CERAMIC 6800PF M		
C434			CE04KW1C221M	ELECTRO 220UF 16WV		
C435-438			CE04KW1HR47M	ELECTRO 0.47UF 50WV		
C439,440			CK45FB1H471K	CERAMIC 470PF K		
C441,442			CE04KW1H1R0M	ELECTRO 1.0UF 50WV		
C443			CE04KW1C101M	ELECTRO 100UF 16WV		
C444			CE04KW1H100M	ELECTRO 10UF 50WV		
C445			CE04KW1A221M	ELECTRO 220UF 10WV		
C446,447			CE04KW1H1R0M	ELECTRO 1.0UF 50WV		
C448			CE04KW1C221M	ELECTRO 220UF 16WV		
C449			CE04KW1H100M	ELECTRO 10UF 50WV		
C450,451			CQ92FM1H472J	MYLAR 4700PF J	M1X1Y1	
C450,451			CQ92FM1H472J	MYLAR 4700PF J	M2	
C452,453			C91-1525-08	CERAMIC 0.1UF Z		
C454,455			CE04KW1H2R2M	ELECTRO 2.2UF 50WV		
C456,457			CE04KW1H100M	ELECTRO 10UF 50WV		
C458			CK45FB1H101K	CERAMIC 100PF K		
C461			CK45FB1H101K	CERAMIC 100PF K		
C462-465			CE04KW1H2R2M	ELECTRO 2.2UF 50WV		
C479,480			CE04KW1C101M	ELECTRO 100UF 16WV		
C481,482			C91-1525-08	CERAMIC 0.1UF Z		
C483,484			CK45FB1H151K	CERAMIC 150PF K		
C485			CE04KW1HR47M	ELECTRO 0.47UF 50WV		
C501,502			CK45FB1H102K	CERAMIC 1000PF K		
C503,504			CE04KW1E470M	ELECTRO 47UF 25WV		
C505			CE04KW1H101M	ELECTRO 100UF 50WV		
C506			C91-1525-08	CERAMIC 0.1UF Z		
C507			CE04KW1H101M	ELECTRO 100UF 50WV		
C508,509			CE04KW1H221M	ELECTRO 220UF 50WV		
C510			C91-1525-08	CERAMIC 0.1UF Z		
C511,512			C91-0717-05	CERAMIC 4.7PF K		
C513,514			CQ92FM1H104J	MYLAR 0.10UF J		
C515,516			CK45FB1E223Z	CERAMIC 0.022UF Z		
C517			CE04KW1H101M	ELECTRO 100UF 50WV		
C518			CE04KW1H1R0M	ELECTRO 1.0UF 50WV		
C519			CE04KW1C470M	ELECTRO 47UF 16WV		
C520			CK45FB1C103K	CERAMIC 0.010UF K		
C521			CE04KW1C101M	ELECTRO 100UF 16WV		
C522			CK45FB1E223Z	CERAMIC 0.022UF Z		
C523			CE04KW1H4R7M	ELECTRO 4.7UF 50WV		
C524			CE04KW1C101M	ELECTRO 100UF 16WV		
C525,526			CK45FB1H102K	CERAMIC 1000PF K	E1E2E3	
C525,526			CK45FB1H102K	CERAMIC 1000PF K	E4T1T2	
C525,526			CK45FB1H102K	CERAMIC 1000PF K	Q1Q2	
C527,528			CK45FB1H102K	CERAMIC 1000PF K		
C529			CE04KW1H4R7M	ELECTRO 4.7UF 50WV		

L : Scandinavia K : USA P : Canada R : Mexico C : China I : Malaysia
Y : PX(Far East, Hawaii) T : Europe E : Europe G : Germany V : China (Shanghai) B : BLACK S : SILVER H : GRAY
Y : AAFES(Europe) X : Australia Q : Russia H : Korea M : Other Areas Δ indicates safety critical components.

PARTS LIST

RXD-251/301/351/371S/A3

* New Parts
Parts without **Parts No.** are not supplied.
Les articles non mentionnés dans le **Parts No.** ne sont pas fournis.
Teile ohne **Parts No.** werden nicht geliefert.

13

Ref. No	Add-ress	New Parts	Parts No.	Description	Desti-nation	Re-marks
C530			C91-1525-08	CERAMIC	0.1UF	Z
C531			CE04KW1H1R0M	ELECTRO	1.0UF	50WV
C532			CE04HW1HR47M	NP-ELEC	0.47UF	50WV
C541, 542			CK45FB1H102K	CERAMIC	1000PF	K
C681-684			CE04KW1H100M	ELECTRO	10UF	50WV
C685-687			CK45FB1H104Z	CERAMIC	0.10UF	Z
C701,702			CE04KW1H332M	ELECTRO	3300UF	50WV
C701,702			CE04KW1H332M	ELECTRO	3300UF	50WV
C701,702			CE04KW1H332M	ELECTRO	3300UF	50WV
C701,702			CE04KW1H332M	ELECTRO	3300UF	50WV
C701,702			CE04KW1H332M	ELECTRO	3300UF	50WV
C701,702			CE04KW1H472M	ELECTRO	3300UF	50WV
C701,702			CE04KW1H472M	ELECTRO	3300UF	50WV
C703-706			CK45FB1E103Z	CERAMIC	0.010UF	Z
C707-710			C91-1525-08	CERAMIC	0.1UF	Z
C711			CE04KW1C471M	ELECTRO	470UF	16WV
C712			CK45FB1E223Z	CERAMIC	0.022UF	Z
C713			CE04KW1C101M	ELECTRO	100UF	16WV
C714			CK45FB1E223Z	CERAMIC	0.022UF	Z
C715			CE04KW1C471M	ELECTRO	470UF	16WV
C716			CK45FB1E223Z	CERAMIC	0.022UF	Z
C718			CK45FB1E223Z	CERAMIC	0.022UF	Z
C719			CE04KW1C101M	ELECTRO	100UF	16WV
C720			CK45FB1E223Z	CERAMIC	0.022UF	Z
C721,722			CE04KW1C101M	ELECTRO	100UF	16WV
C723			CK45FB1E223Z	CERAMIC	0.022UF	Z
C724			CE04KW1C471M	ELECTRO	470UF	16WV
C725			CE04KW1E221M	ELECTRO	220UF	25WV
C726			CE04KW1E222M	ELECTRO	2200UF	25WV
C727			CE04KW1E470M	ELECTRO	47UF	25WV
C728-731			CK45FB1E223Z	CERAMIC	0.022UF	Z
C732			CE04KW1C470M	ELECTRO	47UF	16WV
C733			CE04KW1C471M	ELECTRO	470UF	16WV
C734			CK45FB1E223Z	CERAMIC	0.022UF	Z
C735			CE04KW1H1R0M	ELECTRO	1.0UF	50WV
C736			CE04KW1C101M	ELECTRO	100UF	16WV
C741			C91-1525-08	CERAMIC	0.1UF	Z
CN201			E40-3247-05	PIN ASSY(3P)		
CN202			E40-3249-05	PIN ASSY(5P)		
CN203			E40-3246-05	PIN ASSY(2P)		
CN205			E40-9861-08	PIN ASSY(8P)		
CN301		*	E40-8350-08	PIN ASSY(17P)		
CN302		*	E40-8334-08	PIN ASSY(3P)	M1X1M2	X3
CN302		*	E40-8334-08	PIN ASSY(3P)		
CN402		*	E40-8351-08	PIN ASSY(6P)		
CN403		*	E40-8335-08	PIN ASSY(4P)	M1X1M2	X3
CN403		*	E40-8335-08	PIN ASSY(4P)		
CN605		*	E40-8351-08	PIN ASSY(6P)		
CN701		*	E40-8352-08	PIN ASSY(6P)		
JK301		*	E11-0387-08	JACK(MIC)	M1X1M2	X3
JK301		*	E11-0387-08	JACK(MIC)		
JK302		*	E11-0387-08	JACK(MIC)	M1X1M2	
JK302		*	E11-0387-08	JACK(MIC)		
JK401		*	E63-1073-08	PHONO JACK(2P)	X3	

L : Scandinavia K : USA P : Canada R : Mexico C : China I : Malaysia
Y : PX(Far East, Hawaii) T : Europe E : Europe G : Germany V : China (Shanghai) B : BLACK S : SILVER H : GRAY
Y : AAFES(Europe) X : Australia Q : Russia H : Korea M : Other Areas Δ indicates safety critical components.

* New Parts
Parts without **Parts No.** are not supplied.
Les articles non mentionnés dans le **Parts No.** ne sont pas fournis.
Teile ohne **Parts No.** werden nicht geliefert.

14

Ref. No	Add-ress	New Parts	Parts No.	Description	Desti-nation	Re-marks
JK501		*	E70-0108-08	LOCK TERMINAL BOARD(4P)		
JK502		*	E11-0386-08	JACK(H/P)		
JK601		*	E63-1074-08	PIN JACK(1P)	K1P1	
Δ F701			F04-2025-05	FUSE T2AL250V		K1P1
Δ F701			F06-2021-05	FUSE T2AL250V		E1E2E3
Δ F701			F06-2021-05	FUSE T2AL250V		M1M2M3
Δ F701			F06-2021-05	FUSE T2AL250V		Q1Q2Y1
Δ F701			F06-2021-05	FUSE T2AL250V		T1T2E4
Δ F701			F06-2021-05	FUSE T2AL250V		X1X2X3
Δ F702			F05-1623-05	FUSE T1.6AL250V		E1E2E3
Δ F702			F05-1623-05	FUSE T1.6AL250V		Q1Q2X3
Δ F702			F05-1623-05	FUSE T1.6AL250V		T1T2E4
Δ F702			F05-3121-05	FUSE T3.15AL250V		M3
Δ F702			F06-2021-05	FUSE T2AL250V		X1
Δ F702			F06-3027-05	FUSE T3AL250V		K1K2
Δ F703			F05-4025-05	FUSE T4AL250V		M1M2Y1
Δ F703			F06-2021-05	FUSE T2AL250V		M1M2Y1
Δ F703			F06-2021-05	FUSE T2AL250V		M3
L201		*	L32-1007-08	COIL(BIAS OSC)		
L201		*	L32-1007-08	COIL(BIAS OSC)		
L202		*	L39-1375-08	COIL(CHOKE 470UH)		
L501,502		*	L39-1341-08	COIL(SPRING) 1.0UH		
Δ R485,486			RD14BB2E221J	RD	220	J 1/4W
Δ R507			RD14BB2E101J	RD	100	J 1/4W
Δ R509			RS14GB2H101J	FL-PROOF RS	100	J 1/2W
R527,528		*	R92-1913-08	WIRE WOUND	0.1	K 2D
R529,530		*	RD14GB2H4R7J	RD	4.7	J 1/2W
R533,534		*	RD14GB2H4R7J	RD	4.7	J 1/2W
R535,536		*	RS14GB3A271J	FL-PROOF RS	270	J 1W
R537,538		*	RD14GB2H680J	RD	68	J 1/2W
Δ R700			RD14BB2H475J	RD	4.7M	J 1/2W
Δ R701			RS14GB3A1R0J	FL-PROOF RS	1	J 1W
Δ R703			RS14GB2H101J	FL-PROOF RS	100	J 1/2W
Δ R706			RS14GB3A1R0J	FL-PROOF RS	1	J 1W
R708			RS14GB2H471J	FL-PROOF RS	470	J 1/2W
SFR201			R32-0006-08	VR		
VR601		*	R31-0099-08	VR(MIC)		M1X1M2
VR601		*	R31-0099-08	VR(MIC)		X3
Δ RL501			S76-0048-08	MAGNETIC RELAY		
Δ S701		*	S62-0083-08	SLIDE SWITCH		M1Y1M2
Δ S701		*	S62-0083-08	SLIDE SWITCH		M3
SW201		*	S68-0114-08	SWITCH(REC SW)		
SW751		*	S62-0057-08	SLIDE SWITCH(BEAT CANCEL)		
D201-205			1SS133T-77	DIODE		
D206,207			1N4002	DIODE		
D208,209			1SS133T-77	DIODE		
D211-213			1SS133T-77	DIODE		
D401,402			1SS133T-77	DIODE		
D501-505			1SS133T-77	DIODE		
D581			1SS133T-77	DIODE		
D585			1SS133T-77	DIODE		
Δ D701		*	GBU4D	DIODE		E1E2E3

L : Scandinavia K : USA P : Canada R : Mexico C : China I : Malaysia
Y : PX(Far East, Hawaii) T : Europe E : Europe G : Germany V : China (Shanghai) B : BLACK S : SILVER H : GRAY
Y : AAFES(Europe) X : Australia Q : Russia H : Korea M : Other Areas Δ indicates safety critical components.

PARTS LIST

* New Parts
 Parts without **Parts No.** are not supplied.
 Les articles non mentionnés dans le **Parts No.** ne sont pas fournis.
 Teile ohne **Parts No.** werden nicht geliefert.

15

Ref. No	Address	New Parts	Parts No.	Description	Destination	Remarks
Δ D701		*	GBU4D	DIODE	E4T1T2	
Δ D701		*	GBU4D	DIODE	K1P1M3	
Δ D701		*	GBU4D	DIODE	Q1Q2X2	
Δ D701		*	GBU4D	DIODE	X3	
Δ D701		*	GBU6D	DIODE	M1M2X1	
Δ D701		*	GBU6D	DIODE	Y1	
Δ D702-705			1N4002L	DIODE		
D706			1SS133T-77	DIODE		
D707			MTZ8.2B	ZENER DIODE		
D708			MTZ6.2B	ZENER DIODE		
D709-711			MTZ12B	ZENER DIODE		
D712			1SS133T-77	DIODE		
D714			1SS133T-77	DIODE		
IC201			TA8189N	IC		
IC301			TA2011S	IC	M1X1M2	
IC301			TA2011S	IC	X3	
IC401		*	LC75392	IC		
IC402			TC4066BP	IC(ANALOG/ DIGITAL SW)		
IC404			NJM4558L	IC(OP AMP X2)		
Δ IC501		*	STK-405-100A	IC	M1M2X1	
Δ IC501		*	STK-405-100A	IC	Y1	
Δ IC501		*	STK-405-70A	IC	E1E2E3	
Δ IC501		*	STK-405-70A	IC	E4T1T2	
Δ IC501		*	STK-405-70A	IC	K1P1M3	
Δ IC501		*	STK-405-70A	IC	Q1Q2X2	
Δ IC501		*	STK-405-70A	IC	X3	
IC502			UPC1237HA	IC(POWER AMP)		
IC602			NJM4558L	IC(OP AMP X2)	K1P1	
Q201-206			2SC945	TRANSISTOR		
Q207			2SA733	TRANSISTOR		
Q208			2SC945	TRANSISTOR		
Q209			2SC2001L	TRANSISTOR		
Q210-212			2SC945	TRANSISTOR		
Q213			2SA733	TRANSISTOR		
Q214			DTC124ES	TRANSISTOR		
Q215			2SC945	TRANSISTOR		
Q216			2SA733	TRANSISTOR		
Q217			2SC945	TRANSISTOR		
Q218			2SA733	TRANSISTOR		
Q219			2SC945	TRANSISTOR		
Q220			2SC2001L	TRANSISTOR		
Q301,302			2SC945	TRANSISTOR		
Q403-408			2SC945	TRANSISTOR		
Q409,410			2SA733	TRANSISTOR		
Q411-414			2SC2878A	TRANSISTOR		
Q415,416			2SC945	TRANSISTOR		
Q417,418			DTC114TS	TRANSISTOR		
Q501,502			2SC945	TRANSISTOR		
Q503			2SA733	TRANSISTOR		
Q504,505			2SC1841	TRANSISTOR		
Q506			2SA988	TRANSISTOR		
Q507			DTC124ES	TRANSISTOR		
Q508			2SA733	TRANSISTOR		
Q509,510			DTC124ES	TRANSISTOR		
Q511,512			2SC2878A	TRANSISTOR		

L : Scandinavia K : USA P : Canada R : Mexico C : China I : Malaysia
 Y : PX(Far East, Hawaii) T : Europe E : Europe G : Germany V : China (Shanghai) B : BLACK S : SILVER H : GRAY
 Y : AAFES(Europe) X : Australia Q : Russia H : Korea M : Other Areas Δ indicates safety critical components.

* New Parts
 Parts without **Parts No.** are not supplied.
 Les articles non mentionnés dans le **Parts No.** ne sont pas fournis.
 Teile ohne **Parts No.** werden nicht geliefert.

16

Ref. No	Address	New Parts	Parts No.	Description	Destination	Remarks
Q513			DTA144ES	TRANSISTOR		
Q611			2SC945	TRANSISTOR	K1P1	
Δ Q701,702			2SD882(Q,P)	TRANSISTOR		
Δ Q703			2SC2001L	TRANSISTOR		
Δ Q704			2SD882(Q,P)	TRANSISTOR		
Q705			2SA733	TRANSISTOR		
Q706			2SC945	TRANSISTOR		
Q707			DTC124ES	TRANSISTOR		
Q708			DTC114TS	TRANSISTOR		
Δ Q709			2SA953(K)	TRANSISTOR		
Q711			DTA144ES	TRANSISTOR		
Q713,714			2SC2878A	TRANSISTOR		
DISPLAY UNIT						
LCD601		*	B38-0174-08	LCD DISPLAY		
LP601-603		*	B30-2539-08	PILOT LAMP		
C601			C91-1525-08	CERAMIC	0.1UF	Z
C603		*	C90-3824-08	ELECTRO	4700UF	5.5WV
C604			CK45FB1E223Z	CERAMIC	0.022UF	Z
C605			CE04KW1C470M	ELECTRO	47UF	16WV
C606			C91-1525-08	CERAMIC	0.1UF	Z
C607			CE04KW1H2R2M	ELECTRO	2.2UF	50WV
C608			CE04KW1H010M	ELECTRO	1.0UF	50WV
C609			C91-1525-08	CERAMIC	0.1UF	Z
C610			CE04KW1H100M	ELECTRO	10UF	50WV
C611			CK45FB1E223Z	CERAMIC	0.022UF	Z
C612,613			CC45CH1H200J	CERAMIC	20PF	J
C614			C91-1525-08	CERAMIC	0.1UF	Z
C615,616			C91-0749-05	CERAMIC	220PF	K
C617			CK45FB1H101K	CERAMIC	100PF	K
C618			CE04KW1H100M	ELECTRO	10UF	50WV
C619-621			C91-0749-05	CERAMIC	220PF	K
C622			CE04KW1H010M	ELECTRO	1.0UF	50WV
C623			CE04KW1A101M	ELECTRO	100UF	10WV
C624-628			C91-0749-05	CERAMIC	220PF	K
C629			CE04KW1A101M	ELECTRO	100UF	10WV
C631			CE04KW1A330M	ELECTRO	33UF	10WV
C632			C91-0749-05	CERAMIC	220PF	K
CN09		*	E40-8338-08	FFC PIN ASSY(18P)		
CN401		*	E40-8337-08	PIN ASSY 17P		
L601			L33-0521-08	CHOKE COIL		
X601		*	L77-2244-08	CRYSTAL		
VR603		*	T99-0616-08	VR ENCODER		
SW601-617			S70-0036-08	TACT SWITCH		
SW618-626			S70-0036-08	TACT SWITCH		
D601			1SS133T-77	DIODE		
D602			1N4148	DIODE		
D603,604			1SS133T-77	DIODE		
D607			1SS133T-77	DIODE		E1E2E3
D607			1SS133T-77	DIODE		E4T1T2
D607			1SS133T-77	DIODE		Q1Q2
D613		*	B30-2540-08	LED		E1E2E3

L : Scandinavia K : USA P : Canada R : Mexico C : China I : Malaysia
 Y : PX(Far East, Hawaii) T : Europe E : Europe G : Germany V : China (Shanghai) B : BLACK S : SILVER H : GRAY
 Y : AAFES(Europe) X : Australia Q : Russia H : Korea M : Other Areas Δ indicates safety critical components.

PARTS LIST

RXD-251/301/351/371S/A3

* New Parts
Parts without **Parts No.** are not supplied.
Les articles non mentionnés dans le **Parts No.** ne sont pas fournis.
Teile ohne **Parts No.** werden nicht geliefert.

17

Ref. No	Add-ress	New Parts	Parts No.	Description	Desti-nation	Re-marks
D613		*	B30-2540-08	LED	E4T1T2	
D613		*	B30-2540-08	LED	M1M2M3	
D613		*	B30-2540-08	LED	Q1Q2Y1	
D613		*	B30-2540-08	LED	X1X2X3	
IC601		*	LC867224A-5H71	IC		
Q601,602			2SC945	TRANSISTOR	E1E2E3	
Q603			2SA733	TRANSISTOR	E4T1T2	
Q603			2SA733	TRANSISTOR	M1M2M3	
Q603			2SA733	TRANSISTOR	Q1Q2Y1	
Q603			2SA733	TRANSISTOR		
Q603			2SA733	TRANSISTOR		
Q603			2SA733	TRANSISTOR		
Q604			2SA733	TRANSISTOR	X1X2X3	
Q604			2SA733	TRANSISTOR		
RM601		*	W02-2680-08	REMOTE RECEIVER		
SPEAKER						
		*	B06-0057-08	GRILLE ASSY(BLACK L)	E3E4	B
		*	B06-0057-08	GRILLE ASSY(BLACK L)	T2Q2X3	B
		*	B06-0058-08	GRILLE ASSY(BLACK R)	E3E4	B
		*	B06-0058-08	GRILLE ASSY(BLACK R)	T2Q2X3	B
		*	B06-0059-08	GRILLE ASSY(GRAY L)	E1E2T1	H
		*	B06-0059-08	GRILLE ASSY(GRAY L)	K1P1Y1	H
		*	B06-0059-08	GRILLE ASSY(GRAY L)	M1M2X1	H
		*	B06-0059-08	GRILLE ASSY(GRAY L)	Q1	H
		*	B06-0060-08	GRILLE ASSY(GRAY R)	E1E2T1	H
		*	B06-0060-08	GRILLE ASSY(GRAY R)	K1P1Y1	H
		*	B06-0060-08	GRILLE ASSY(GRAY R)	M1M2X1	H
		*	B06-0060-08	GRILLE ASSY(GRAY R)	Q1	H
		*	H50-2991-08	ITEM CARTON CASE(LS-N301)	E3E4T2	
		*	H50-2991-08	ITEM CARTON CASE(LS-N301)	Q2	
		*	H50-2997-08	ITEM CARTON CASE(LS-N351)	E2M3	
		*	H50-2997-08	ITEM CARTON CASE(LS-N351)	T1E1Q1	
		*	H50-2998-08	ITEM CARTON CASE(LS-N371S)	M1M2	
		*	T03-0505-08	TWEETER UNIT(MULTIPLE)		
		*	T10-1004-08	WOOFER UNIT(40W 5INCH)		
		*	T10-1005-08	WOOFER UNIT(60W 6.5INCH)		
		*	W03-5839-05L	SPEAKER(LS-N301)LEFT	E3E4	
		*	W03-5839-05R	SPEAKER(LS-N301)RIGHT	E3E4	
		*	W03-5839-05L	SPEAKER(LS-N301)LEFT	T2Q2X3	
		*	W03-5839-05R	SPEAKER(LS-N301)RIGHT	T2Q2X3	
		*	W03-5840-05L	SPEAKER(LS-N351)LEFT	K1P1Q1	
		*	W03-5840-05R	SPEAKER(LS-N351)RIGHT	K1P1Q1	
		*	W03-5840-05L	SPEAKER(LS-N351)LEFT	T1E1E2	
		*	W03-5840-05R	SPEAKER(LS-N351)RIGHT	T1E1E2	
		*	W03-5840-05L	SPEAKER(LS-N351)LEFT	X2M3	
		*	W03-5840-05R	SPEAKER(LS-N351)RIGHT	X2M3	
		*	W03-5841-05L	SPEAKER(LS-N371)LEFT	M1X1Y1	
		*	W03-5841-05R	SPEAKER(LS-N371)RIGHT	M1X1Y1	
		*	W03-5841-05L	SPEAKER(LS-N371)LEFT	M2	
		*	W03-5841-05R	SPEAKER(LS-N371)RIGHT	M2	

L : Scandinavia K : USA P : Canada R : Mexico C : China I : Malaysia
Y : PX(Far East, Hawaii) T : Europe E : Europe G : Germany V : China (Shanghai) B : BLACK S : SILVER H : GRAY
Y : AAFES(Europe) X : Australia Q : Russia H : Korea M : Other Areas Δ indicates safety critical components.

HOW TO READ THE PARTS LIST

ABBREVIATION OF MODEL AND MASS PRODUCTION'S DESTINATIONS

MODEL	ABB.	Australia	Canada	China	England	Europe	Germany	Korea	Malaysia
RXD-251	-	X2	-	-	-	-	-	-	-
RXD-301	-	X3	-	-	T2	E3	-	-	-
RXD-301E	-	-	-	-	-	E4	-	-	-
RXD-301W	-	-	-	-	-	-	-	-	-
RXD-351	-	X1	-	-	T1	E1	-	-	-
RXD-351E	-	-	-	-	-	E2	-	-	-
RXD-351W	-	-	-	-	-	-	-	-	-
RXD-371S	-	-	-	-	-	-	-	-	-
RXD-A3	-	-	P1	-	-	-	-	-	-
MODEL	ABB.	Mexico	PX/AAFES	Russia	Scandinavia	Shanghai	USA	Other area	
RXD-251	-	-	-	-	-	-	-	M3	-
RXD-301	-	-	-	-	-	-	-	-	-
RXD-301E	-	-	-	-	-	-	-	-	-
RXD-301W	-	-	-	Q2	-	-	-	-	-
RXD-351	-	-	Y1	-	-	-	-	M1	-
RXD-351E	-	-	-	-	-	-	-	-	-
RXD-351W	-	-	-	Q1	-	-	-	-	-
RXD-371S	-	-	-	-	-	-	-	M2	-
RXD-A3	-	-	-	-	-	-	K1	-	-

Note :

Every individual parts is not available for repair parts on cassette and cd mechanisms.

Schematic is printed to check cd-circuitry, however, no parts list in this manual.

SPECIFICATIONS

Main unit

[Amplifier section]

(XD-A3)

Rated power output (U.S.A. and Canada)

30 watts per channel minimum RMS, both channels driven, at 6 Ω from 40 Hz to 14 kHz with no more than 0.9 % total harmonic distortion.

Effective output power during STEREO operation

U.S.A. and Canada

1 kHz, 10 % T.H.D., 6 Ω 40 W + 40 W

(XD-251/XD-301)

Effective output power during STEREO operation

1 kHz, 10 % T.H.D., 6 Ω 40 W + 40 W

Rated output power during STEREO operation

Europe, U.K. and Russia

(DIN) 1 kHz, 0.7 % T.H.D., 6 Ω 30 W + 30 W

Other countries

1 kHz, 1.0 % T.H.D., 6 Ω 30 W + 30 W

(XD-351/XD-371S)

Effective output power during STEREO operation

Europe, U.K. and Russia.

1 kHz, 10 % T.H.D., 6 Ω 40 W + 40 W

Other countries

1 kHz, 10 % T.H.D., 6 Ω 60 W + 60 W

Rated output power during STEREO operation

Europe, U.K. and Russia

(DIN) 1 kHz, 0.7 % T.H.D., 6 Ω 30 W + 30 W

Other countries

1 kHz, 1.0 % T.H.D., 6 Ω 40 W + 40 W

Input sensitivity / impedance

AUX 300 mV / 40 k Ω

(XD-351/XD-371S)

MIC 1, 2 (Except for some areas) 2.5 mV / 2.2 k Ω

Output level / impedance

(XD-A3)

SUPER WOOFER PREOUT 1.8 V / 0.6 k Ω

[Tuner section]

FM tuner section

Tuning frequency range 87.5 MHz ~ 108 MHz

(For Russia) (87.5 MHz ~ 108 MHz

65.0 MHz ~ 74.0 MHz

AM (MW) Tuner section

Tuning frequency range

Europe, U.K. and Russia 531 kHz ~ 1,602 kHz

U.S.A. and Canada 530 kHz ~ 1,700 kHz

Other countries

9 kHz step 531 kHz ~ 1,602 kHz

10 kHz step 530 kHz ~ 1,610 kHz

LW Tuner section (For U. K.)

Tuning frequency range 153 kHz ~ 279 kHz

SW Tuner section (XD-371S)

Tuning frequency range 5.95 MHz ~ 17.9 MHz

[Cassette deck section]

Track 4-track, 2-channel stereo

Recording system AC bias system
(Frequency: 105 kHz)

Heads

A deck Playback / recording head 1

Erasing head 1

B deck Playback head 1

Motor 1

Fast winding time Approx. 100 seconds
(C-60 tape)

[CD player section]

Laser Semiconductor laser

Wow & Flutter Less than unmeasurable Limit

[General]

Power consumption (XD-A3/XD-251/XD-301) 150 W

(XD-351 for Europe 5 and U.K.) 150 W

(XD-371S) 180 W

Dimensions W: 280 mm (11")

H: 320 mm (12-5/8")

D: 405 mm (15-15/16")

Weight (net) (XD-A3/XD-251/XD-301) 6.9kg (15.2 lb)

(XD-351 for Europe and U.K.) 6.9kg (15.2 lb)

(XD-351 for other countries) 9.1kg (20.1 lb)

(XD-371S) 9.1kg (20.1 lb)

Speakers (LS-N301/LS-N351) XD-A3/XD-251/XD-351 (Europe,

U.K. and Russia)

Enclosure Bass-reflex type

Speaker configuration

Woofers 130 mm, cone type

Tweeter 50 mm, cone type

Impedance 6 Ω

Maximum input level 40 W

Dimensions W: 220 mm (8-11/16")

H: 320 mm (12-5/8")

D: 295 mm (11-5/8")

Weight (net) 3.3 kg (7.3 lb) (1 piece)

Speakers (LS-N371) XD-351 (other countries)/XD-371S

Enclosure Bass-reflex type

Speaker configuration

Woofers 160 mm, cone type

Tweeter 50 mm, cone type

Impedance 6 Ω

Maximum input level 60 W

Dimensions W: 220 mm (8-11/16")

H: 320 mm (12-5/8")

D: 295 mm (11-5/8")

Weight (net) 3.7 kg (8.2 lb) (1 piece)



1. KENWOOD follows a policy of continuous advancements in development. For this reason specifications may be changed without notice.
2. Sufficient performance may not be possible at very low temperatures (0°C or less).

RXD-251/301/351/371S/A3

Note:

Component and circuit are subject to modification to insure best operation under differing local conditions. This manual is based on Europe (E) standard, and provides information on regional circuit modification through use of alternate schematic diagrams, and information on regional component variations through use of parts list.

KENWOOD CORPORATION

14-6, Dogenzaka 1-chome, Shibuya-ku, Tokyo, 150-8501 Japan

KENWOOD SERVICE CORPORATION

P.O. BOX 22745, 2201 East Dominguez St., Long Beach, CA 90801-5745, U.S.A.

KENWOOD ELECTRONICS CANADA INC.

6070 Kestrel Road, Mississauga, Ontario, Canada L5T 1S8

KENWOOD ELECTRONICS LATIN AMERICA S.A.

P.O. BOX 55-2791, Piso 6 plaza Chase, Cl. 47 y Aquilino de la Guardia Panama, Republic de Panama

KENWOOD ELECTRONICS BRASIL LTDA.

Av Indianópolis, 628, 04062-001 Planalto Paulista São Paulo-SP-Brasil

KENWOOD ELECTRONICS U.K. LIMITED

KENWOOD House, Dwight Road, Watford, Herts., WD1 8EB., United Kingdom

KENWOOD ELECTRONICS BELGUM N.V.

Meachelsesteenweg 418, B-1930 Zaventem, Belgium

KENWOOD ELECTRONICS DEUTSCHLAND GMBH

Rembrücker Str. 15, 63150 Heusenstamm, Germany

KENWOOD ELECTRONICS FRANCE S.A.

13 Boulevard Ney, 75018 Paris, France

KENWOOD ELECTRONICS ITALIA S.p.A.

Via G. Sirtori, 7/9 20129, Milano, Italy

KENWOOD IBÉRICA S.A.

Bolivia, 239-08020 Barcelona, Spain

KENWOOD ELECTRONICS AUSTRALIA PTY. LTD.

(A.C.N. 001499 074)

P.O. Box 504, 8 Figtree Drive, Australia Centre, Homebush, N.S.W. 2140, Australia

KENWOOD & LEE ELECTRONICS, LTD.

Unit 3712-3724, Level 37, Tower 1, Metroplaza, 223 Hing Fong Road, Kwai Fong N.T., Hong Kong

KENWOOD ELECTRONICS GULF FZE

P.O. Box 61318, Jebel Ali, Dubai, U.A.E.

KENWOOD ELECTRONICS SINGAPORE PTE LTD.

No. 1 Genting Lane #02-02, KENWOOD Building, Singapore, 349544

KENWOOD ELECTRONICS (MALAYSIA) SDN BHD.

#4.01 Level 4, Wisma Academy Lot 4A, Jalan 19/1 46300 Petaling Jaya Selangor Darul Ehsan Malaysia

KENWOOD ELECTRONICS (THAILAND) CO., LTD.

573/111 Soi Ramkhamhaeng 39, Ramkhamhaeng Road, Wangthonglang, Bangkok, Bangkok 10301 Thailand