

Figure is RXD-701.

*** Refer to parts list on page41.**

In compliance with Federal Regulations, following are reproduction of labels on, or inside the product relating to laser product safety.

KENWOOD-Crop. certifies this equipment conforms to DHHS Regulations No.21 CFR 1040. 10, Chapter 1, subchapter J.

**DANGER : Laser radiation when open and interlock defeated.
AVOID DIRECT EXPOSURE TO BEAM.**







RXD-NV301/NV301E/NV701/NV701E

CONTENTS / ACCESSORIES / CAUTIONS

Contents

CONTENTS / ACCESSORIES / CAUTIONS.....	2	PC BOARD	14
EXTERNAL VIEW.....	3	SCHEMATIC DIAGRAM	21
DISASSEMBLY FOR REPAIR.....	4	EXPLODED VIEW	39
CIRCUIT DESCRIPTION.....	6	PARTS LIST.....	41
ADJUSTMENT.....	10	SPECIFICATIONS	51
WIRING DIAGRAM.....	12		

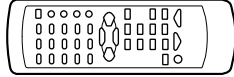
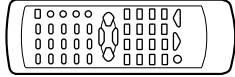
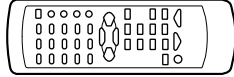
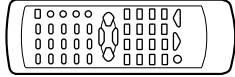
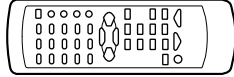
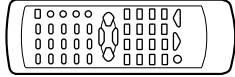
Accessories

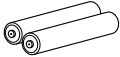
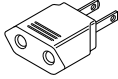
<p>FM indoor antenna(1) (T90-0830-08)</p> 	<p>AM loop antenna (1) (T90-0804-08)</p> 	<p>Remote control unit(1)</p> <table border="0"> <tr> <td>(A70-1459-08): ETE2 (A70-1475-08): KMX</td> <td>(A70-1460-08): ETE2 (A70-1461-08): KMX</td> </tr> <tr> <td></td> <td></td> </tr> <tr> <td>RC-NV301E RC-NV301</td> <td>RC-NV701E RC-NV701</td> </tr> </table>		(A70-1459-08): ETE2 (A70-1475-08): KMX	(A70-1460-08): ETE2 (A70-1461-08): KMX			RC-NV301E RC-NV301	RC-NV701E RC-NV701
(A70-1459-08): ETE2 (A70-1475-08): KMX	(A70-1460-08): ETE2 (A70-1461-08): KMX								
									
RC-NV301E RC-NV301	RC-NV701E RC-NV701								
<p>Speaker cords NV-301 (2) NV-701 (6)</p>  <p>(Speaker cords are provided in the speaker package. Be sure to check that the correct lengths have been provided.)</p>	<p>Batteries (R6/AA)</p> 	<p>AC plug adaptor (1) (E03-0115-05)</p>  <p>Use to adapt the plug on the power cord to the shape of the wall outlet. (Accessory only for regions where use is necessary.)</p>							

System configurations(RXD-NV301/NV701)

SYSTEM	MAIN UNIT	DESTINATION	SPEAKER	SP CORD PARTS No	SPEAKER	SP CORD PARTS No
NV-301	RXD-NV301	KMXTE	LS-NV701	E30-5500-05	-	-
NV-301E	RXD-NV301E	E2	LS-NV701	E30-5500-05	-	-
NV-701	RXD-NV701	KMXYTE	LS-NV701	E30-5500-05	CRW-NV701	E30-5858-05 E30-5859-05
NV-701E	RXD-NV701E	E2	LS-NV701	E30-5500-05	CRW-NV701	E30-5858-05 E30-5859-05

Cautions

Operation to reset

The microcomputer may fall into malfunction (impossibility to operate, erroneous display, etc.) if the power cord is unplugged while power is ON or due to an external factor. In this case, execute the following procedure to reset the microcomputer and return it to normal condition.

Unplug the power cord from the power outlet then, while holding the SET (●) key depressed, plug the power cord again

(Main unit only)

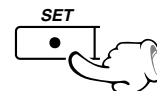

● Please note that resetting the microcomputer clears the stored contents and returns to the factory set condition.

EXTERNAL VIEW

RXD-NV701

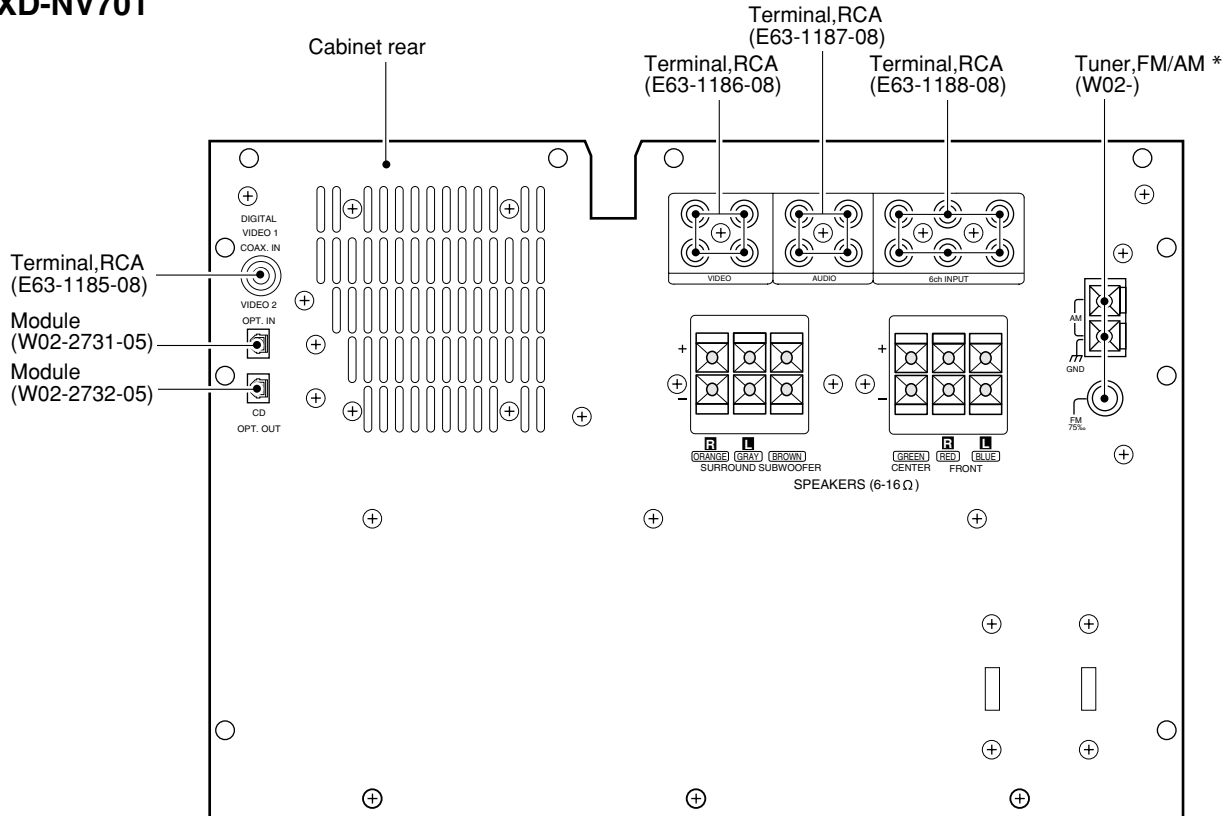

RXD-NV301

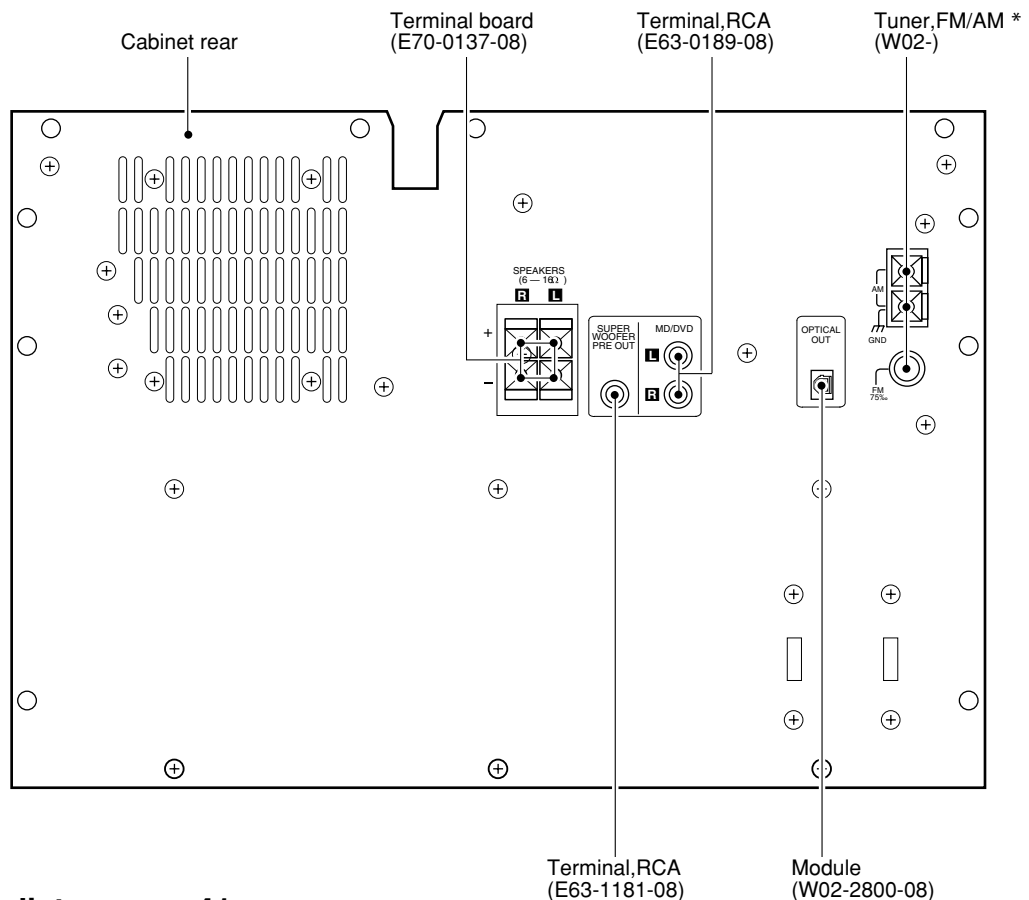

* Refer to parts list on page 41.

RXD-NV301/NV301E/NV701/NV701E

DISASSEMBLY FOR REPAIR

1. How to Remove the Front Panel

1. Remove screws (1)X2 and CD cover.
2. Remove screws (2)X4 and (3)X2.

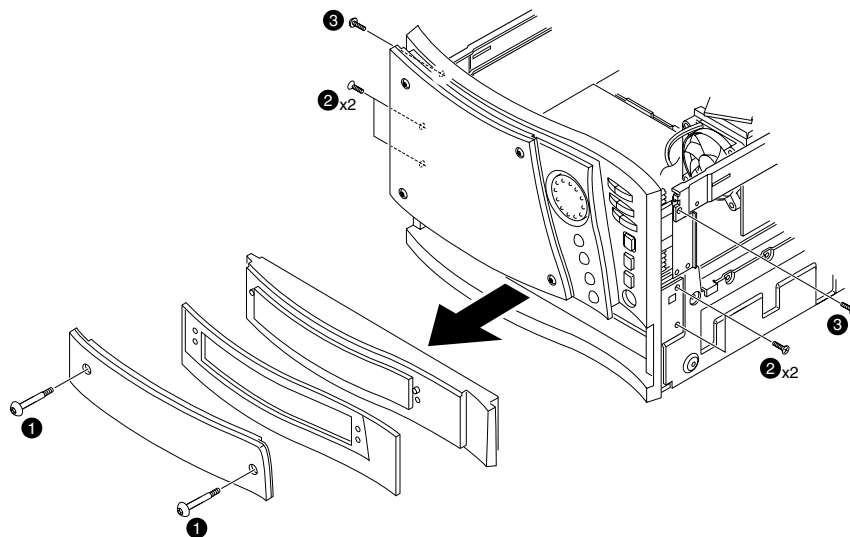

Fig 1.

3. Remove screws (4)X3 on the bottom plate.

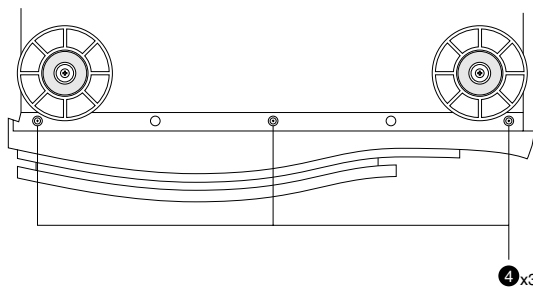

Fig 2.

4. Remove screws (5)X4.

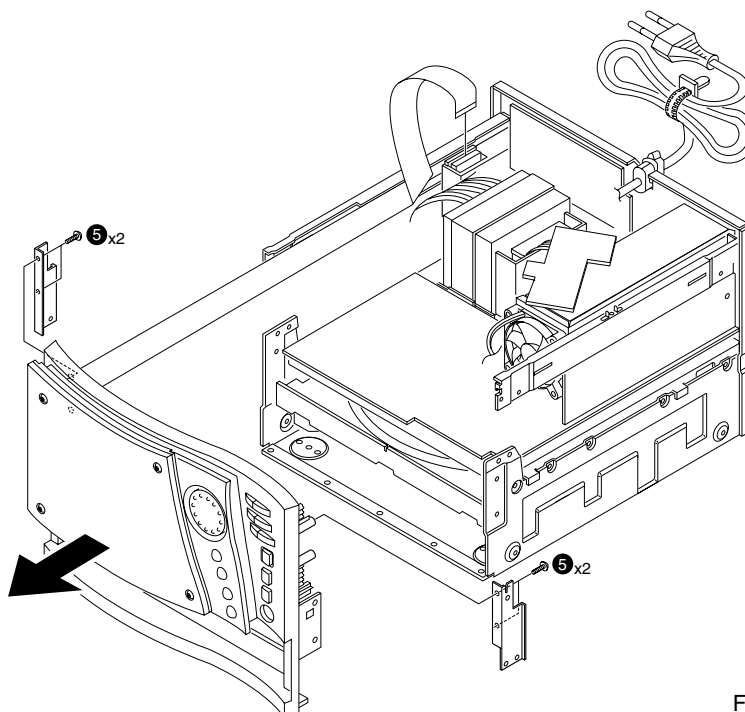
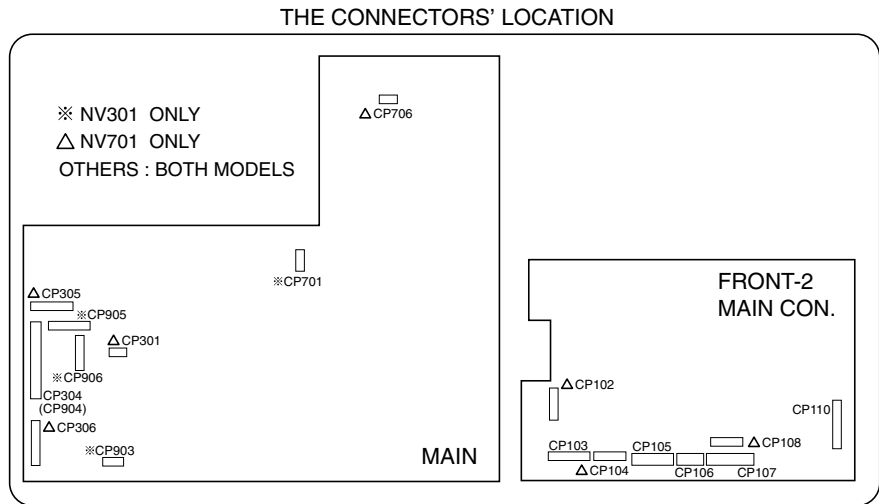

Fig 3.

DISASSEMBLY FOR REPAIR

5. To separate the front panel, remove connectors listed below.



2. How to Remove the CD Mechanism

1. Rear panel and main unit can be separated by removing screws (6)X3 and (7)X3.

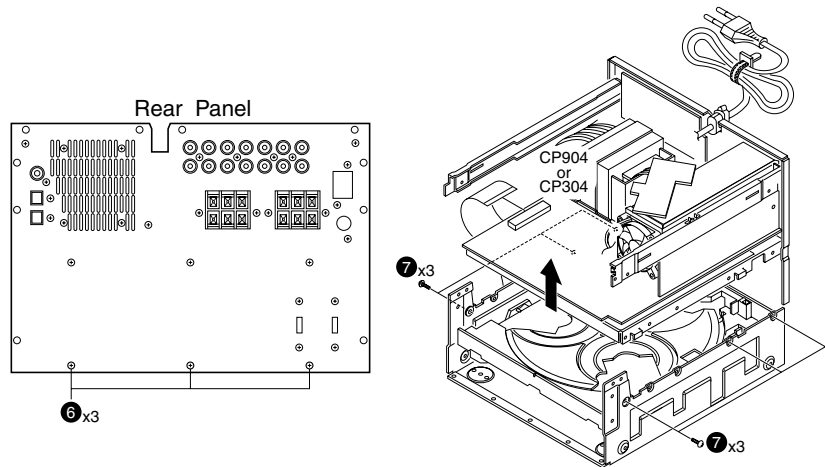

Fig 4.

2. Remove screws (8)X4 and CD mechanism.

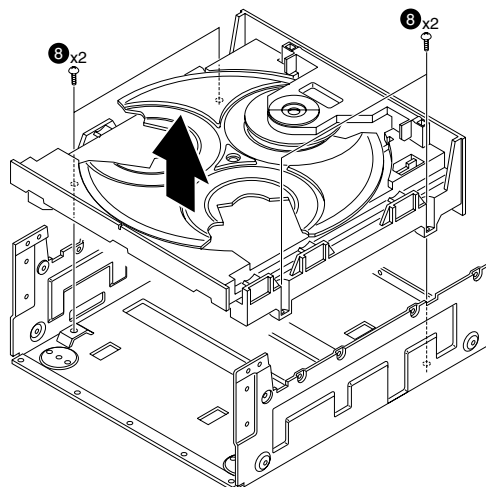

Fig 5.

CIRCUIT DESCRIPTION

1. Pin description of microprocessor : IC2

CXP82852-183Q(RXD-NV301)/CXP82860-185Q(RXD-NV701)

Pin No.	Pin Name	I/O	Description
1,2	NC	-	Unused.
3	VDD	-	Power supply.
4	POWER DOWN	I	Input port for power down.
5	VOLUME DOWN	I	Pulse input of volume encoder(down).
6	RDS CLK	I	RDS clock input.
7	VOLUME UP	I	Pulse input of volume encoder(up).
8	REMOCON	I	Remote control data input.
9	RDS DATA	I	RDS data input.
10,11	NC	-	Unused.
12	PROTECTION	I	Detection signal input for protection.
13	CrO2	I	Input port of CrO2 detection switch for deck.
14	REEL DATA	I	Input port of reel data.
15	AMS IN	I	AMS input.
16	SYS DATA	O	Data output to volume IC(IC313) for NV701. Data output to function IC(IC301) for NV301.
17	SYS CLK	O	Clock output to volume IC(IC313) for NV701. Clock output to function IC(IC301) for NV301.
18	DIGI 1	I/O	Communication with FL driver IC.
19	DIGI 2	I/O	Communication with FL driver IC.
20	H/P SENSE	I	Detection port of headphones jack.
21	912CSB NC	O -	Sub DSP chip select for NV701. Unused for NV301.
22	912SCK TUNER CLK	O O	Clock output to YSS912(IC603) for NV701. Clock output to PLL IC(IC2) for NV301.
23	912SO NC	O -	Serial data output to YSS912(IC603) for NV701. Unused for NV301.
24	912SI NC	I -	Serial data input from YSS912(IC603) for NV701. Unused for NV301.
25	912CS NC	O -	Chip select to YSS912(IC603) for NV701. Unused for NV301.
26	TUNED	I	Tuned input.
27	STEREO	I	Stereo signal input.
28	VREF	-	Reference voltage.
29,30	KEY1,KEY2	I	A/D key input.
31	VSM	I	Tuner signal meter A/D input.
32	TUNER DO	I	PLL IC data input.
33	MODE(DECK)	I	Deck mode switch input.
34	STATUS	I	Deck pack in/rec in/off sense port.
35	AREA SELECT	I	Selection of destination for tuner.
36	THERMAL PROTECT	I	Detection port of thermometer.
37	AVSS	-	Connected to ground.
38	RESET	I	Reset signal input.
39	EXTAL	I	Input port of crystal oscillator.
40	XTAL	O	Output port of crystal oscillator.
41	VSS	-	Connected to ground.
42	TX	-	Port for 32.768kHz crystal oscillation.
43	TEX	-	Port for 32.768kHz crystal oscillation.
44	VDD	-	Power supply.
45	VFDP	-	Connected to ground.
46	SOLENOID	O	Control port of solenoid for deck.
47	MOTOR ON	O	Control port of motor for deck.
48	DECK MUTE	O	Control port of deck mute.
49	REC MUTE	O	Control port of rec mute.
50	DOLBY	O	Dolby noise reduction output for deck.
51	BEAT CUT	O	Output port of AM beat cut for deck.
52	CrO2- REC	O	Control port of rec bias for deck.
53	REC/PB	O	Selection of recording and playback for deck.
54	CD POWER DOWN	O	Control port of CD power down.

CIRCUIT DESCRIPTION

Pin No.	Pin Name	I/O	Description
55	4226 CS NC	O -	Chip select to CS4226(IC602) for NV701. Unused for NV301.
56	4226 PDN NC	O -	Power down to CS4226(IC602) for NV701. Unused for NV301.
57	HIGH SPEED	O	Control port of high speed for deck.
58	62446 LATCH NC	O -	Latch control to M62446FP(IC313) for NV701. Unused for NV301.
59	TUNER MUTE	O	Muting control port for tuner.
60	7821 CLK NC	O -	Clock output to LC7821(IC311) for NV701. Unused for NV301.
61	7821 DI NC	O -	Data output to LC7821(IC311) for NV701. Unused for NV301.
62	7311 STB NC	O -	Strobe output to NJM7311AM(IC312) for NV701. Unused for NV301.
63	MAIN MUTE	O	Control port for main muting on/off.
64	PHONE MUTE	O	Control port for headphones muting on/off.
65	FRONT RLY	O	Control port for front relay.
66	STANDBY RLY	O	Control port for standby relay.
67	ATT	O	Control port for attenuation.
68	TUNER CE	O	Control port of chip enable for tuner.
69	TUNER DI	O	Data output to PLL IC.
70	7821CE NC	O -	Chip enable to LC7821(IC311) for NV701. Unused for NV301.
71	TUNER LED	O	Control port of tuner led on/off.
72	DECK LED	O	Control port of deck led on/off.
73	STANDBY RED	O	Control port of standby led(red) on/off.
74	STANDBY GREEN	O	Control port of standby led(green) on/off.
75	AUX LED	O O	Control port of video1/2,6ch led on/off for NV701. Control port of AUX led on/off for NV301.
76	CD LED	O	Control port of CD led on/off.
77	FAN CONTROL	O	Control port for fan.
78~88	NC	-	Unused.
89	VDD	-	Power supply.
90~100	NC	-	Unused.

2. Pin Description of DOLBY Digital /Prologic/DTS recording IC : YSS912(IC603)-NV701ONLY

Pin No.	Pin Name	I/O	Description
1	VDD	-	+5V power supply.
2	RAMCEN	-	Unused.
3,4	RAMA16,15	-	Unused.
5~7	SDIB0~2	I+	PCM input 0~2 to Sub DSP.
8	X1	I	Crystal oscillator connection (12.288MHz).
9	XO	O	Crystal oscillator connection.
10	VSS	-	Ground.
11	AVDD	-	+3.3V power supply (for PLL circuit).
12	SDIB3	-	Unused.
13,14	TEST	-	Unused.
15	OVFB	-	Unused.
16	DTSDATA	-	Unused.
17	AC3DATA	-	Unused.
18	SDOB3	-	Unused.
19	CPO	O	Output terminal for PLL, to be connected to ground through the external analog filter circuit.
20	AVSS	-	Ground (for PLL circuit).
21	VDD	-	+3.3V power supply (for core logic).
22~24	SDOA2~SDOA0	-	Unused.
25~29	RAMA14~RAMA10	-	Unused.
30	VSS	-	Ground.

CIRCUIT DESCRIPTION

Pin No.	Pin Name	I/O	Description
31	VDD	-	+5V power supply.
32	CEN MUTE	O	Muting control of center channel.
33	SURR MUTE	O	Muting control of surround channel.
34	C/SW RLY	O	Center/sub woofer relay control.
35	SURR RLY	O	Surround relay control.
36	SW MUTE	O	Muting control of sub woofer channel.
37	FRONT ON/OFF	O	Control port of front channel on/off.
38,39	OPORT6,7	-	Unused.
40	VSS	-	Ground.
41	VDD	-	+3.3V power supply (for core logic).
42~44	RAMA9~7	-	Unused.
45~47	SDOB2~0	O	PCM output from Sub DSP.
48	SDBCK1	I+	Bit clock input for SDOA, SDIB, SDOB.
49	SDWCK1	I+	Word clock input for SDOA, SDIB, SDOB.
50	VSS	-	Ground.
51	VDD	-	+3.3V power supply (for core logic).
52	NONPCM	-	Unused.
53	CRC	-	Unused.
54	MUTE	-	Unused.
55	KARAOKE	-	Unused.
56	SURENC	-	Unused.
57	SDBCK0	-	Unused.
58,59	RAMA6,5	-	Unused.
60	VSS	-	Ground.
61	RAMA4	-	Unused.
62	IC	I	Initial clear.
63	TEST	-	Unused.
64	RAMA3	-	Unused.
65	CSB	I	Sub DSP chip select.
66	CS	I	Microprocessor interface chip select input.
67	SO	O	Microprocessor interface serial data output.
68	SI	I	Microprocessor interface/Sub DSP serial data input.
69	SCK	I	Microprocessor interface/Sub DSP clock input.
70	RAMA2	-	Unused.
71	VDD	-	+5V power supply.
72~79	RAMD0~RAMD7	-	Unused.
80	VSS	-	Ground.
81	VDD	-	+3.3V power supply (for core logic).
82	SDWCK0	I	Word clock input for SDIA, SDOA, SDIB, SDOB.
83	SDBCK0	I	Bit clock input for SDIA, SDOA, SDIB, SDOB.
84,85	SDIA0,SDIA1	I	AC-3 bitstream (or PCM) data input for main DSP.
86,87	RAMA1,0	-	Unused.
88	RAMWEN	-	Unused.
89	RAMOEN	-	Unused.
90	VSS	-	Ground.
91	VDD	-	+3.3V power supply (for core logic).
92	IPOINT7	I+	Analog signal input connection for the right.
93,94	IPOINT6,5	I+	Analog signal input connections for the left channels.
95	IPOINT4	I+	OPT 1 input terminal.
96	IPOINT3	I+	Coaxial input terminal.
97	IPOINT2	I+	To be connected to pin 85.
98,99	IPOINT1,0	I+	Input terminal with a pull-up resistor.
100	VSS	-	Ground.

NOTE :I+ Input terminal with a pull-up resistor

CIRCUIT DESCRIPTION

3. Pin description of FL driver IC : CXP82832(IC101)

Pin No.	Pin Name	I/O	Description
1,2	15G,16G	O	Grid signal(15G,16G) output.
3	VDD	-	Power supply(+5.0V).
4	POWER DOWN	-	Connected to ground.
5	FOK	I	FOK data input.
6	SCOR	I	Sub code-Q read out timing input.
7,8	NC	-	Connected to ground.
9	SENSE	I	Sense signal input.
10~12	NC	-	Unused.
13	PLUSE	I	Input pulse to find CD numbering position.
14	XRST	O	Output for resetting CXD3017Q(IC501).
15	CD MUTE	O	Control port of mute on/off.(at L is active)
16	SYSTEM OFF	O	Control port of system off.
17	XLAT	O	Serial latch data output.
18	LD ON	O	Output to on/off laser.
19	TEST SW	-	Unused.
20	NC	-	Unused.
21	MPEG CS	-	Unused.
22	MPEG CLK	-	Unused.
23	MPEG DATA	-	Unused.
24	MPEG DATA	-	Unused.
25	SQCK	O	Clock data output for sub code-Q read out.
26	SQSO	I	Sub code-Q data input.
27	DATA	O	Serial data output.
28	VREF	-	Reference voltage(+5.0V).
29	DIG LINK	I/O	Communication with main microprocessor.
30	DIG LINK	I/O	Communication with main microprocessor.
31	DOWN SW	I	Input to detect that pick-up is down.
32	UP SW	I	Input to detect that pick-up is up.
33	OPEN SW	I	Input to detect that tray is opened.
34	CLOSE SW	I	Input to detect that tray is closed.
35,36	NC	-	Unused.
37	AVSS	-	Connected to ground.
38	RESET	I	Input port for resetting to CPU. (at L is active)
39	EXTAL	I	Input port of 10MHz crystal oscillator.
40	XTAL	O	Output port of 10MHz crystal oscillator.
41	VSS	-	Connected to ground.
42	NC	-	Unused.
43	VSS	-	Connected to ground.
44	VDD	-	Power supply(+5.0V).
45	VFD	-	Power supply(-30V) for FL display.
46	OPEN SW	O	Output to open the tray or down the pick-up.
47	CLOSE SW	O	Output to close the tray or up the pick-up.
48	RTL	O	Output to rotate the roulette ccw.
49	RTR	O	Output to rotate the roulette cw.
50	SPEED DOWN	O	Output to decrease roulette speed. (at H is active)
51,52	P1,P2	O	Segment signal output.
53	P3	O	Connected to ground.
54~85	P4~P35	O	Segment signal output.
86~88	1G~3G	O	Grid signal(1G,3G) output.
89	VDD	-	Power supply(+5.0V).
90~100	4G~14G	O	Grid signal(4G~14G) output.

4. Key Matrix

Input Voltage	OV	0.42V	0.84V	1.27V	1.74V	2.25V	2.63V
KEY 1 (29Pin)	STOP	SET	DOWN	UP	ENTER	MENU/DEMO	-
KEY2 (30Pin)	CD	TUNER	TAPE	MD/DVD	OPEN	DISC SKIP	1/⊕

() : Port of IC2(u-COM)

ADJUSTMENT

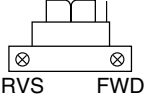
NO.	ITEM	INPUT SETTING	OUTPUT SETTING	CASSETTE TAPE DECK SETTING	ALIGNMENT POINTS	ALIGN FOR	FIG.
Unless otherwise specified, set the respective switches as follows TAPE: NORMAL DOLBY: OFF I Cassette mechanism unit (Adjustment of the REC / PLAY head)						0dBs = 0.775V	
(1)	Demagnetization and cleaning			Power : OFF Demagnetization, cleaning, PLAY	Recording head, erase head, capstan pinch roller	Demagnetize the REC / PLAY head with the head eraser. Clean the REC / PLAY head, erase head, capstan and pinch roller using a cotton swab slightly damped with alcohol.	
(2)	Azimuth of the REC / PLAY head	SCC-1727 TCC-153 MTT-114 10kHz, -10dB	TP401(L) TP402(R)	PLAY		Adjust the output to maximum and adjust the azimuth adjustment screw for the Lissajours waveform pattern of the oscilloscope to become close to a 45° straight line.	
II PC BOARD ADJUSTMENT							
(1)	TAPE SPEED (NORMAL)	TCC-110 MTT-111 SCC-1727 3KHZ	TP401(L) TP402(R)	PLAY	VR407	Adjust the tape speed so that 3kHz is obtained at the center of the tape.	
III PC board adjustment.							
(1)	PLAYBACK LEVEL	TCC-130 400Hz	TP401(L) TP402(R)	PLAY	VR401(L) VR402(R)	Adjust the playback output to -6dBs.	
(2)	SIGNAL CURRENT	(A) Adjust the AG for the output of the deck to be come -20dBs at 400Hz.	TP401(L) TP402(R)	REC PLAY	VR403(L) VR404(R)	-20dBs	
(3)	BIAS CURRENT	(A) 12.5kHz, -20dB Insert CrO2 blank TAPE	Connect a DC voltmeter as follows. TP405(Lch), TP404(Rch)	REC PAUSE	VR405(L) VR406(R)	7mV(NV701) 5.5mV(NV301)	

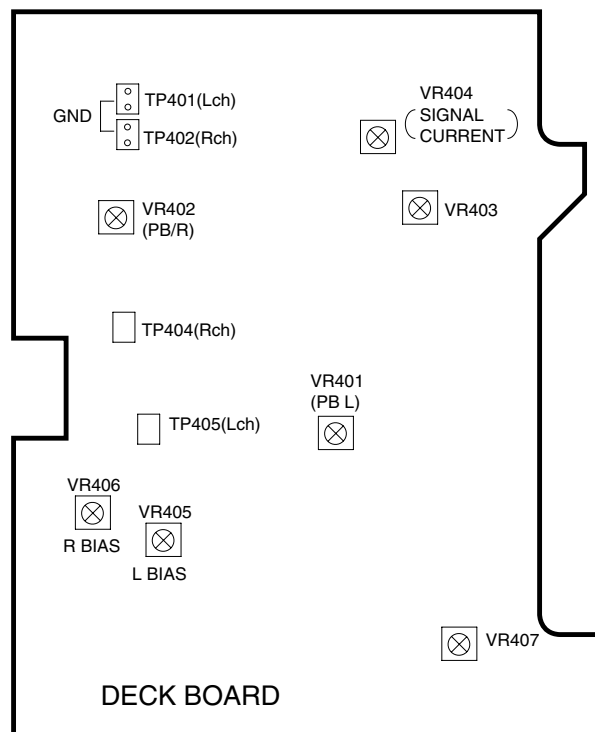

ADJUSTMENT

Measurement equipment connections

NV701

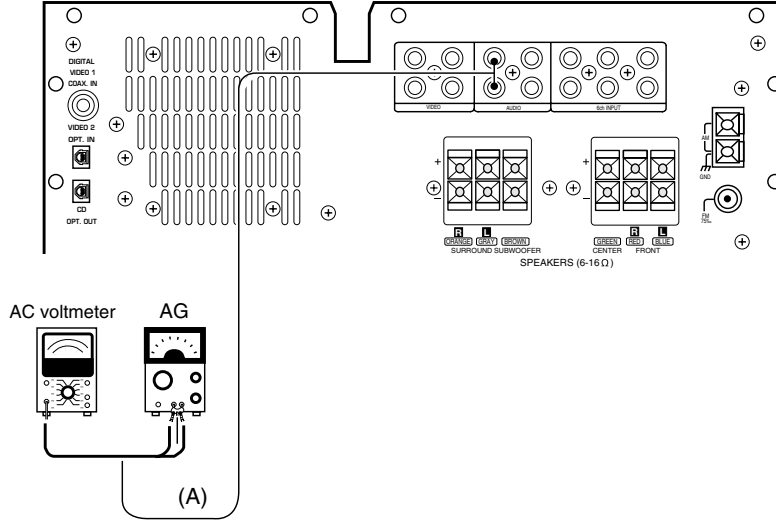

NV301

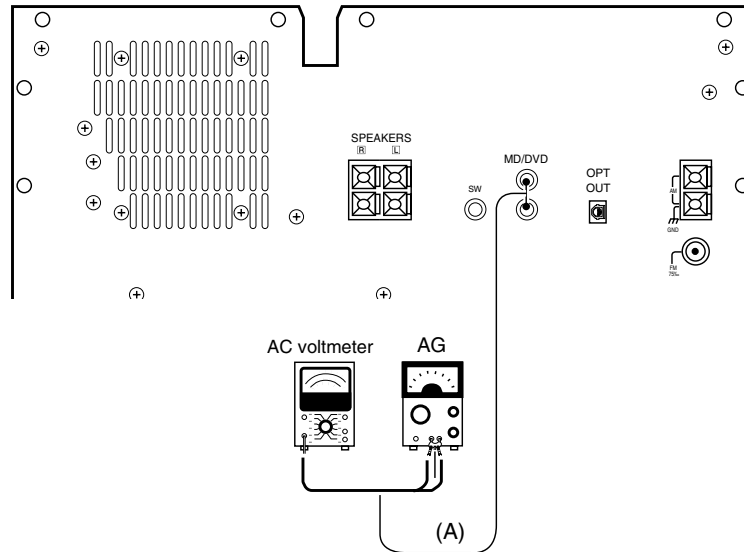

WIRING DIAGRAM

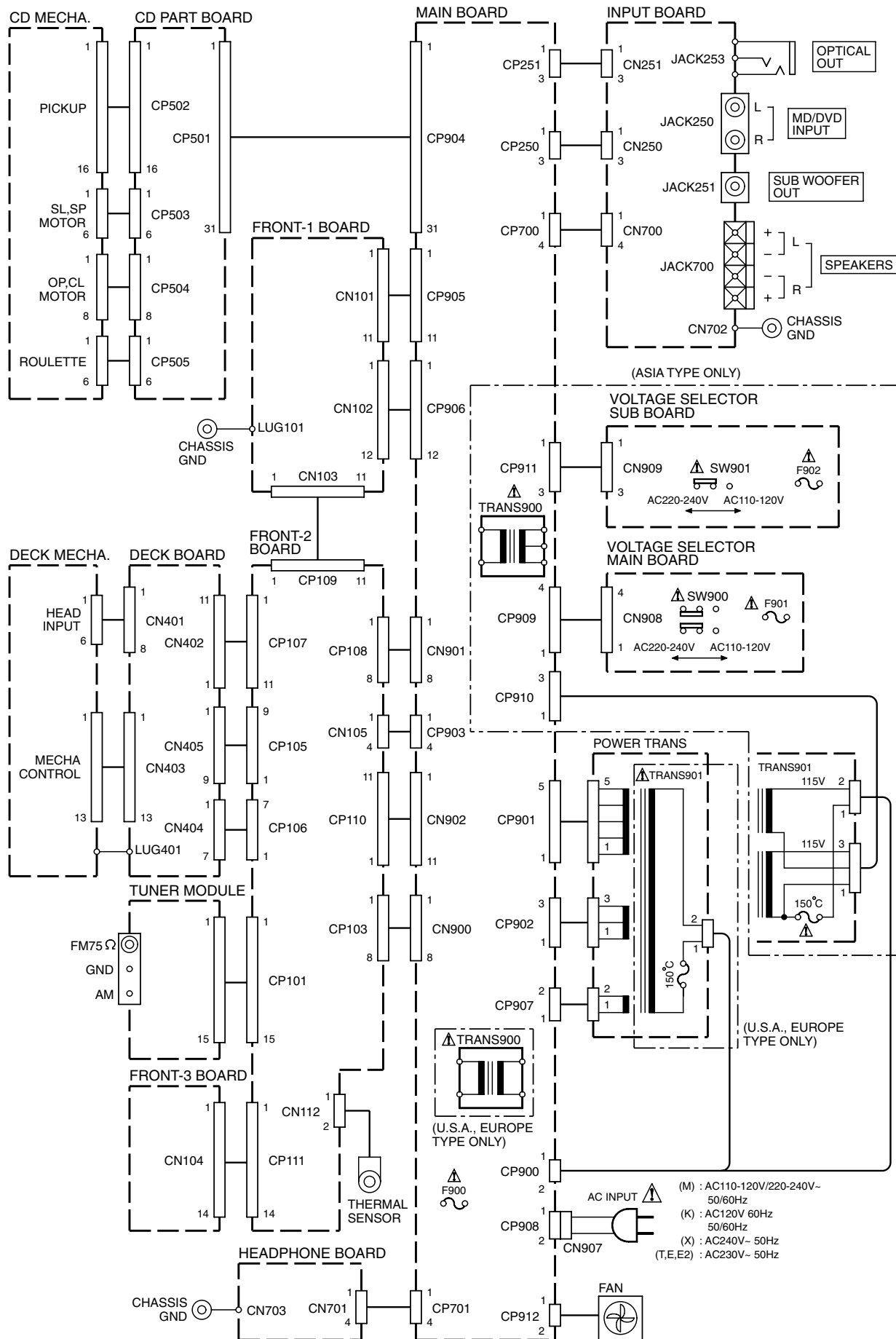

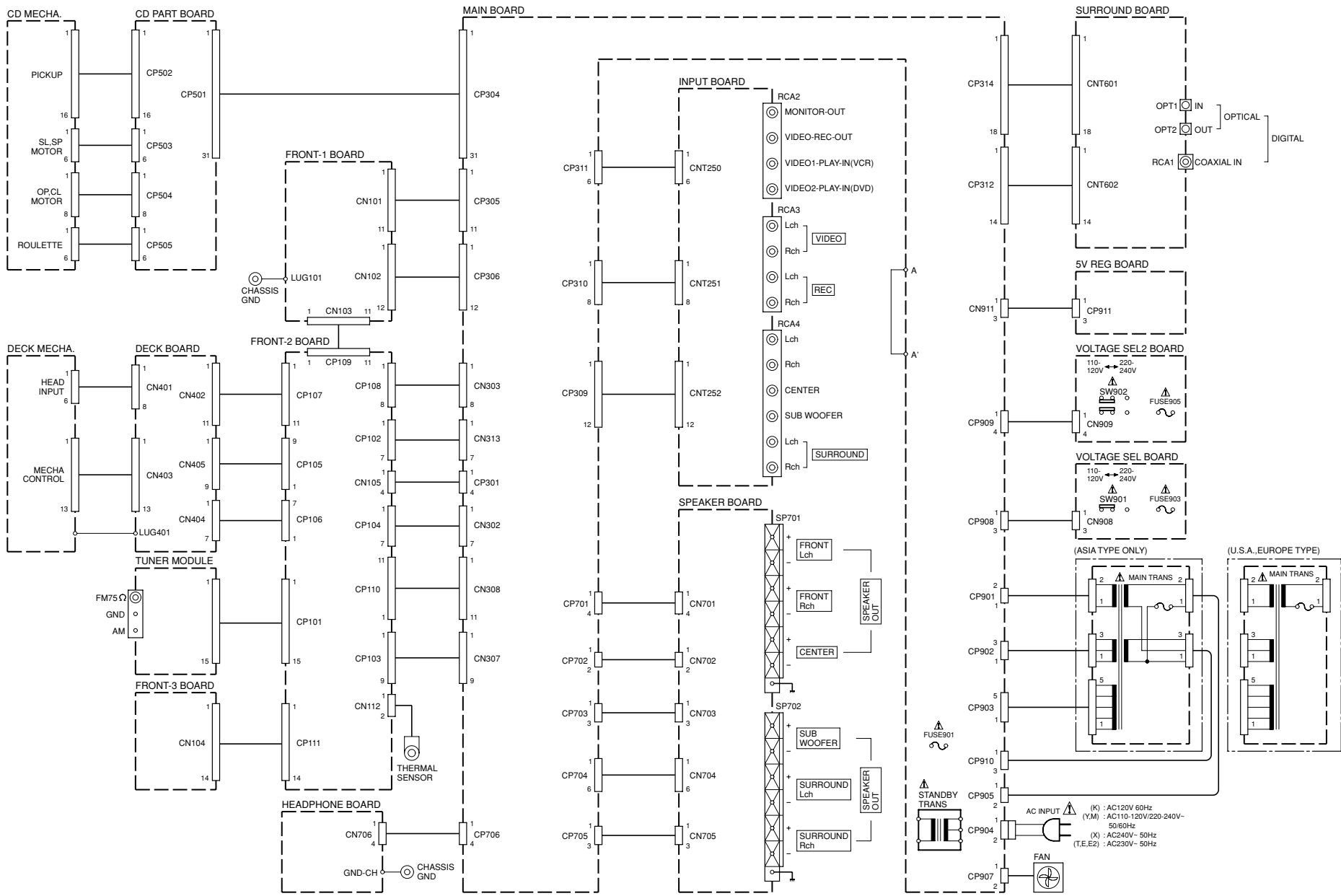

WIRING DIAGRAM

RXD-NV301/NV301E/NV701/NV701E

PC BOARD (Component side view): RXD-NV701

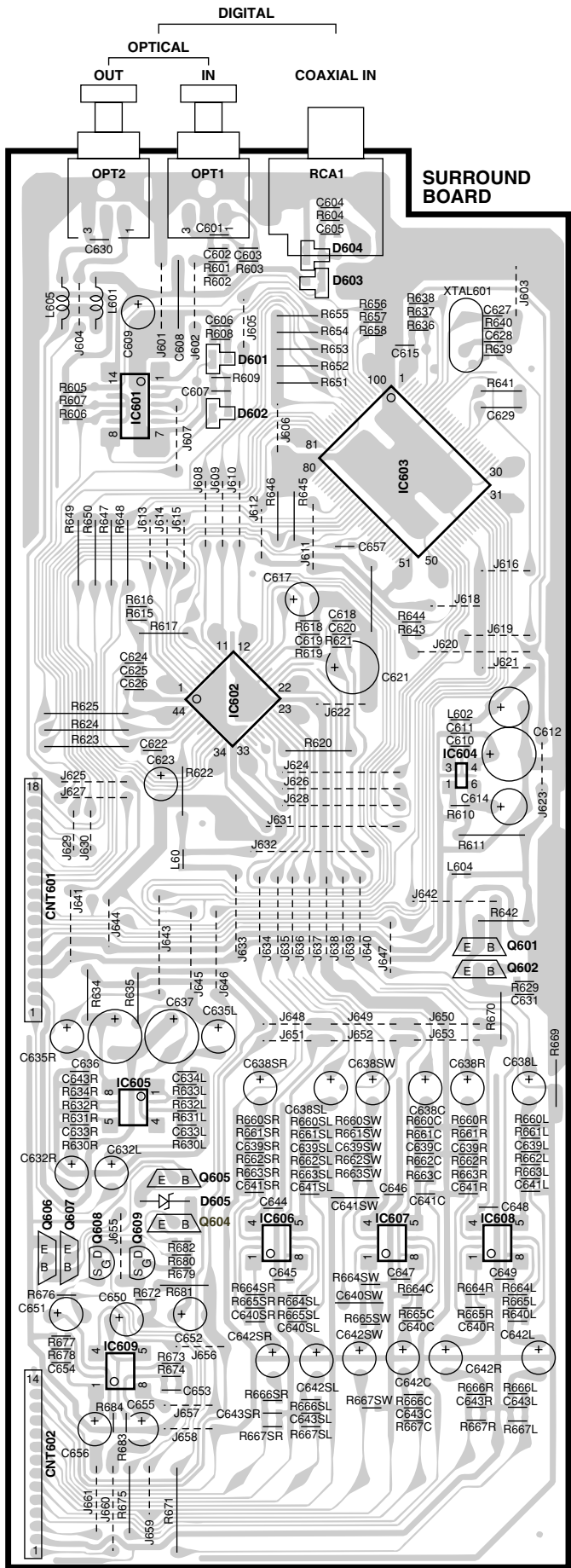
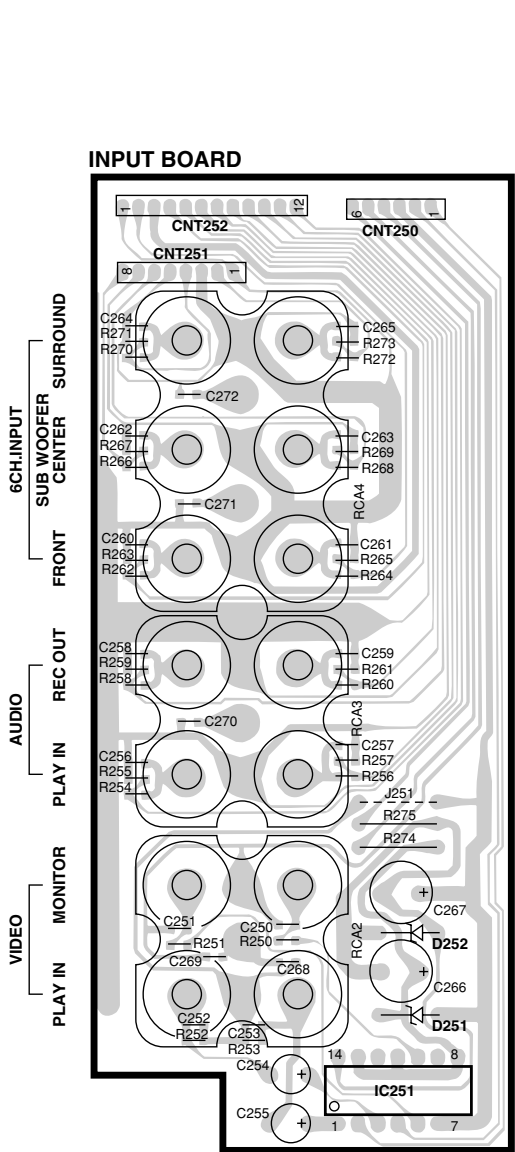

PC BOARD(Component side view)

FRONT-2 BOARD

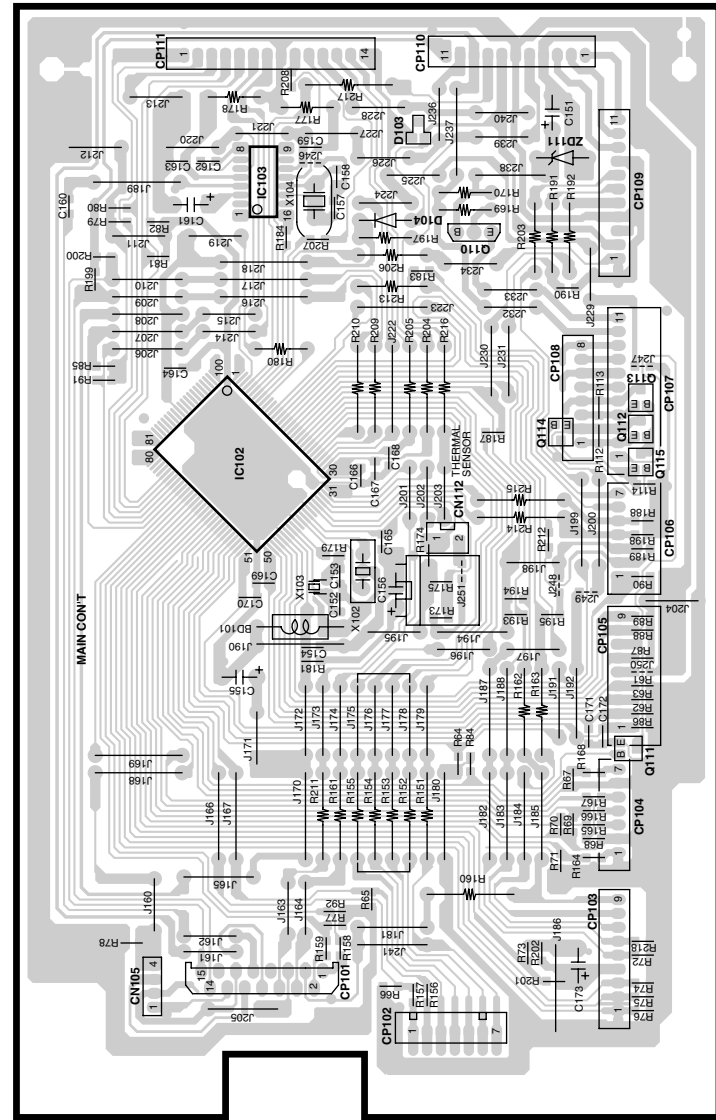

FRONT-1 BOARD

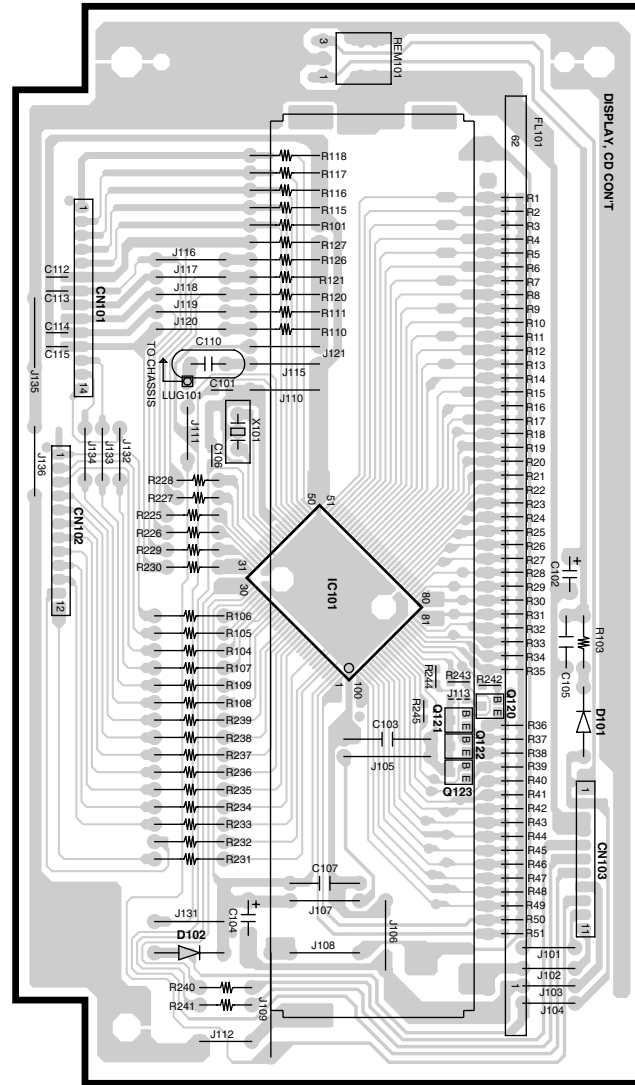

DECK BOARD

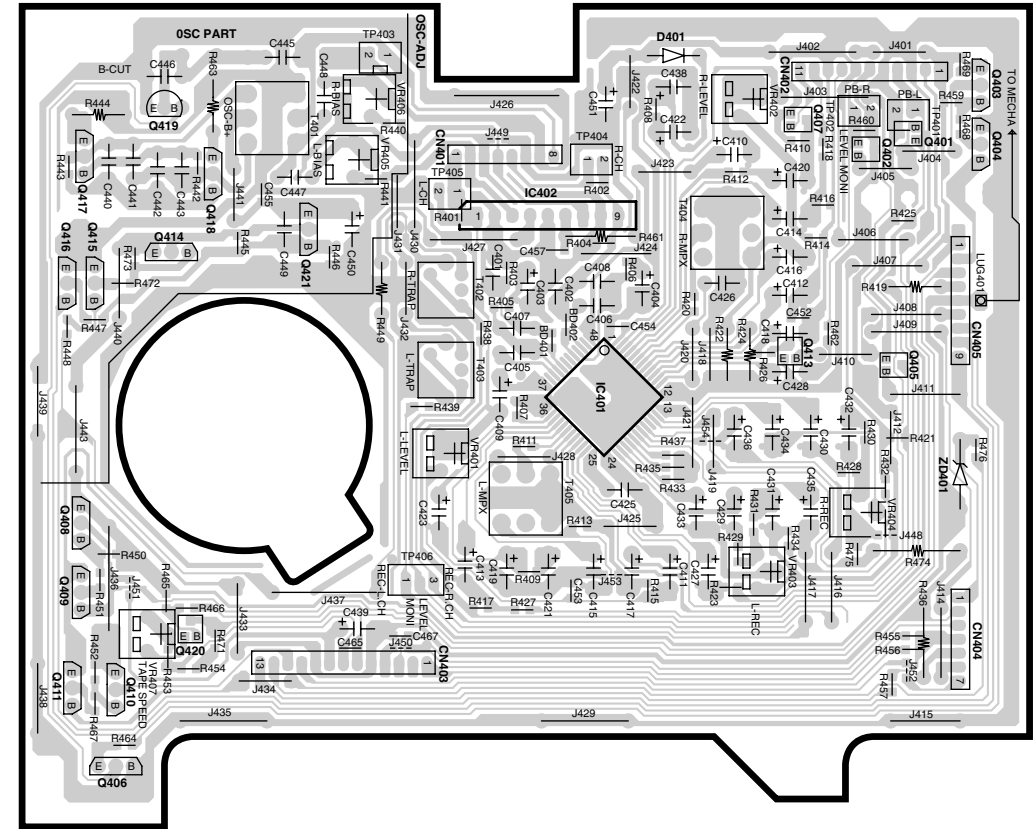

CD BOARD

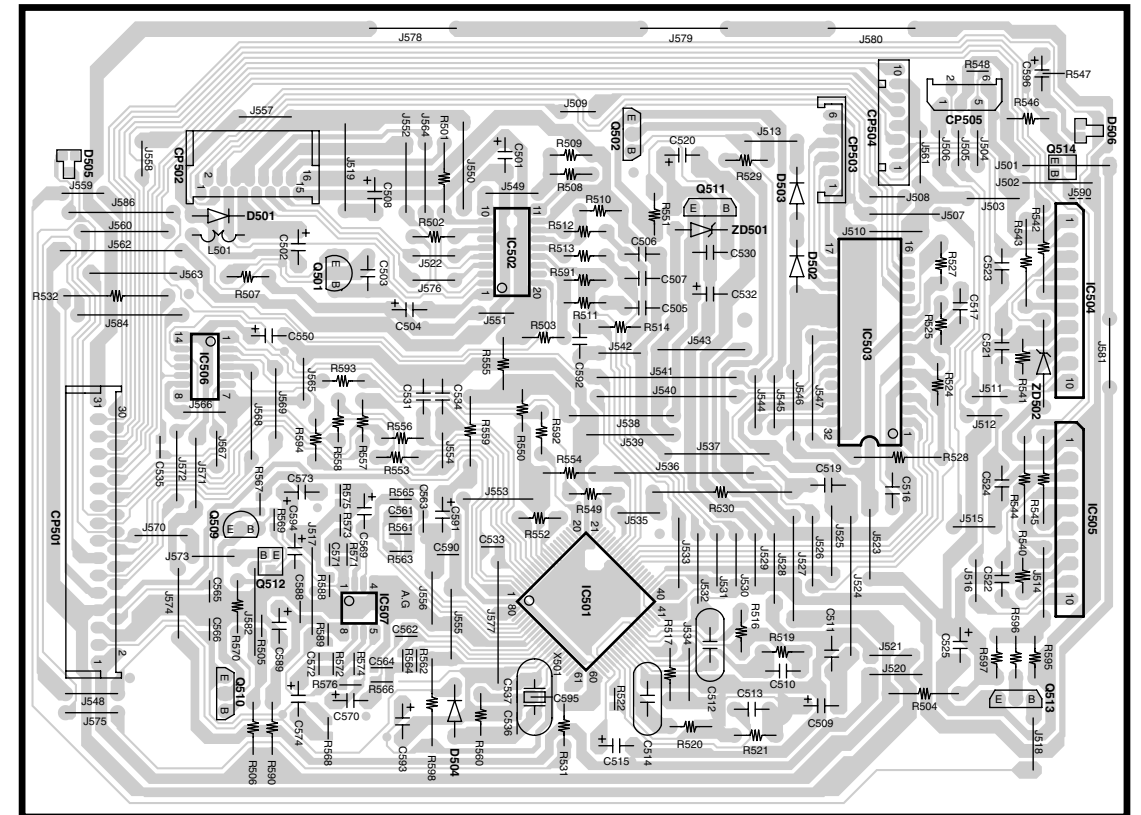

FRONT-3 BOARD

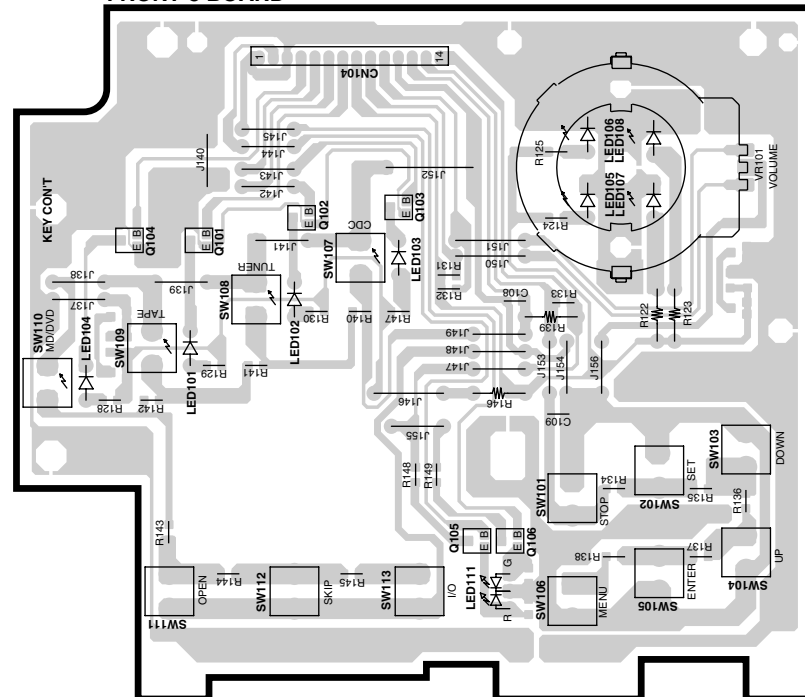

Refer to the schematic diagram for the value of resistors and capacitors.

PC BOARD(Component side view): RXD-NV301

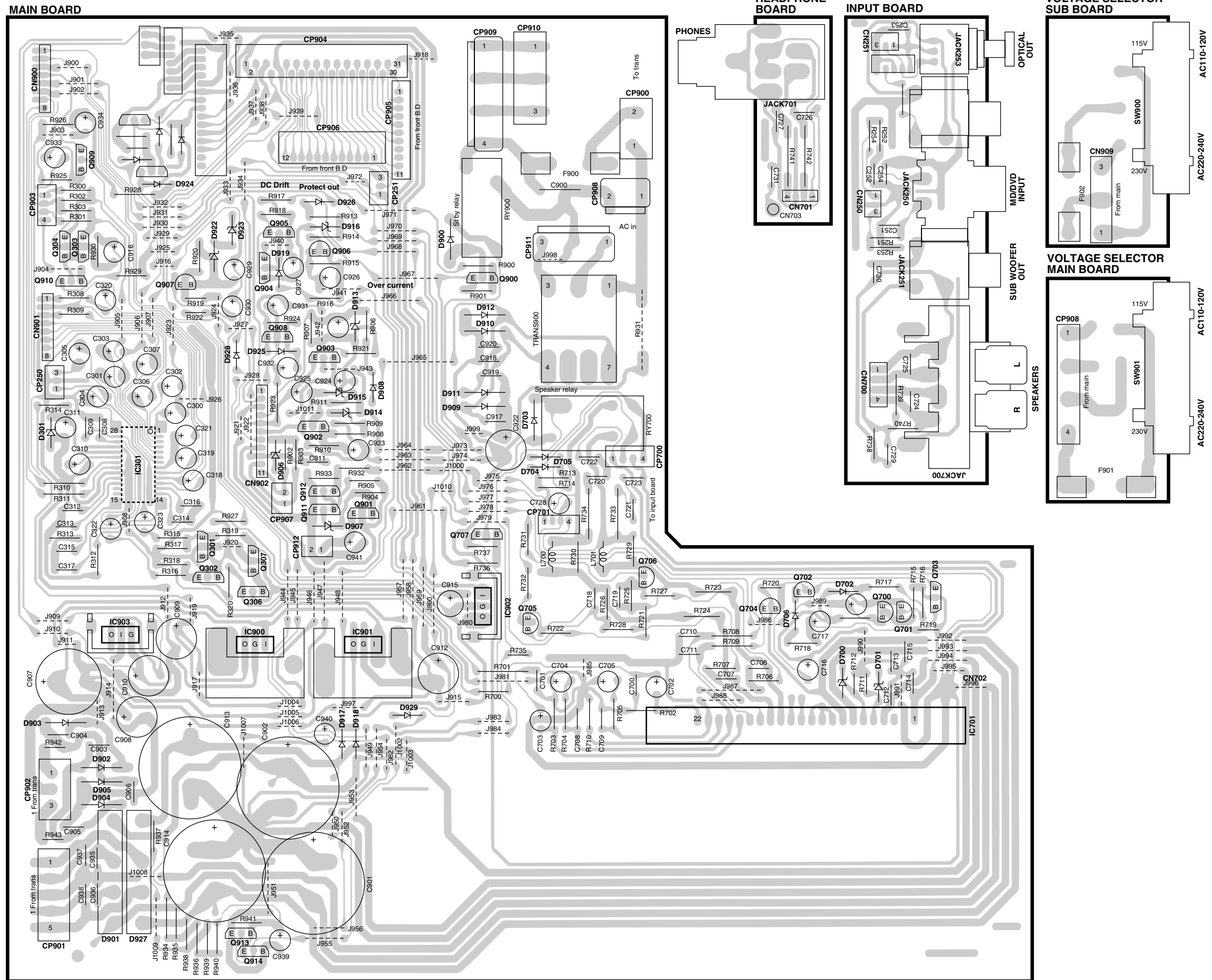

PC BOARD (Component side view): RXD-NV701

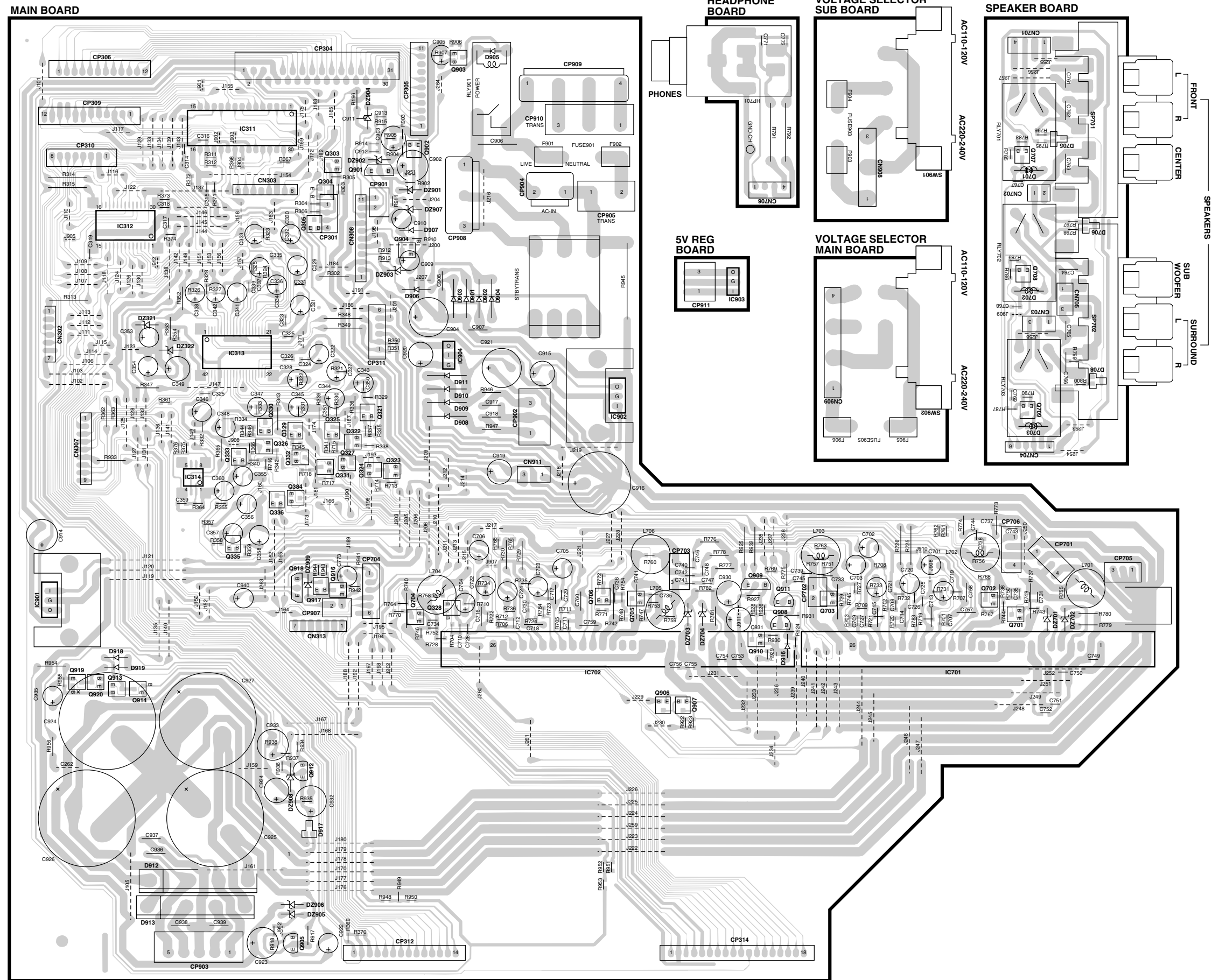

Refer to the schematic diagram for the value of resistors and capacitors.

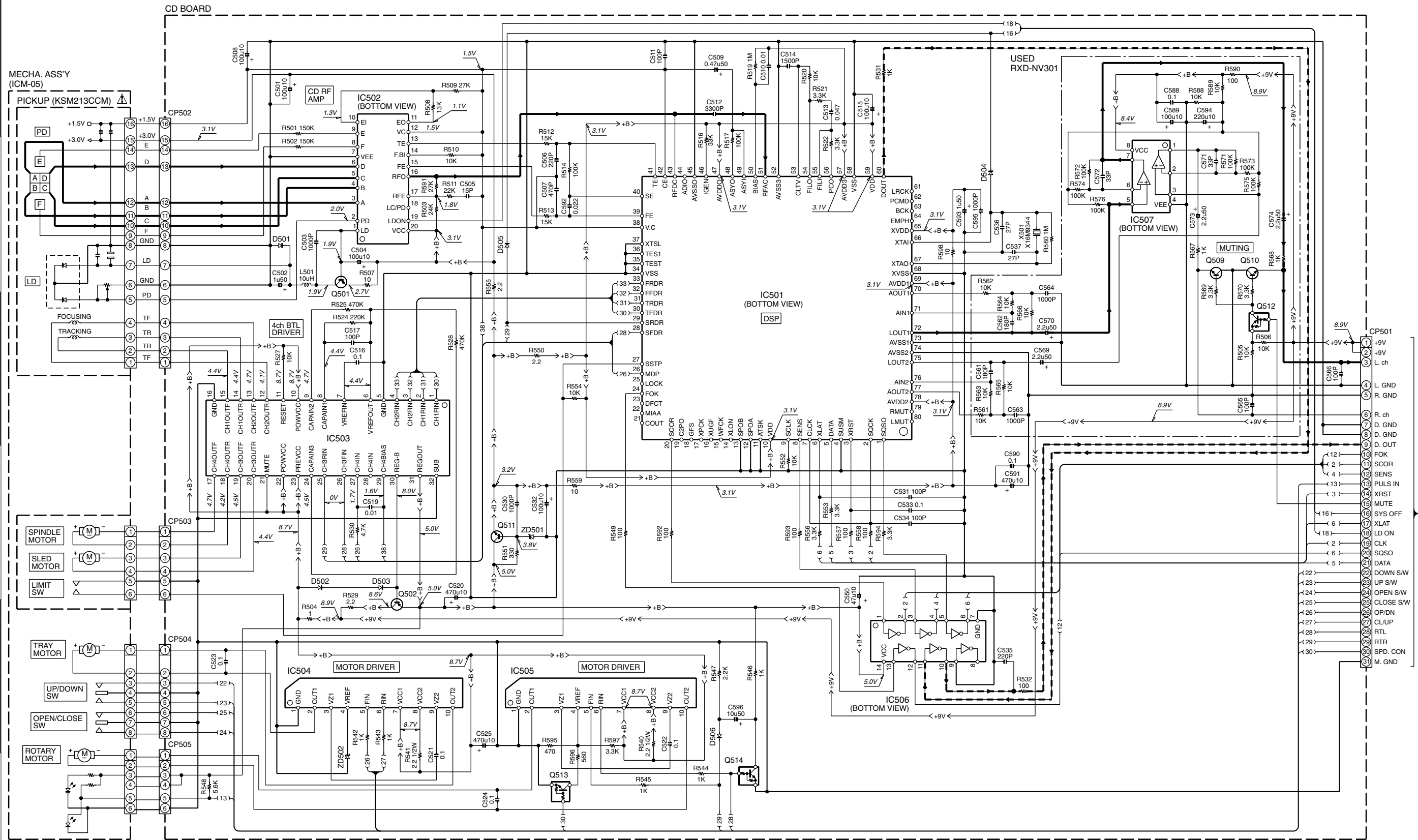

- - - DIGITAL LINE
 ——— SIGNAL LINE
 ——— GND LINE
 <-B- - +B LINE

IC501 : CXD3017Q	Q501 : 2SA1270(Y)	D501-504 : 1SS133	RXD-NV301(E,T,M,X,K,E2) (1/5)
IC502 : CXA1821M	Q502 : KTA1273Y	D505,506 : KDS226	RXD-NV701(E,T,M,X,K,E2,Y) (1/6)
IC503 : BA5979S	Q509,510 : KTC2874B	ZD501 : MTZJ3.9B	
IC504,505 : KA3082	Q511 : 2SC3205Y	ZD502 : MTZJ5.1B	
IC506 : TC74HCT7007AF	Q512 : DTA114EK		
IC507 : NJM4565MD	Q513 : DTC114YS		
	Q514 : DTC114EK		

CAUTION: For continued safety, replace safety critical components only with manufacturer's recommended parts (refer to parts list). Δ indicates safety critical components. For continued protection against risk of fire, replace only with same type and rating fuse(s). To reduce the risk of electric shock, leakage-current or resistance measurements shall be carried out (exposed parts are acceptably insulated from the supply circuit) before the appliance is returned to the customer.

The DC voltage is an actual reading measured with a high impedance type voltmeter. The measurement value may vary depending on the measuring instruments used or on the product. Refer to the voltage during PLAY unless otherwise specified; The value shown in () is the voltage measured at the moment of STOP.

RXD-NV301/NV301E/NV701/NV701E

Y39-3640-10

KENWOOD

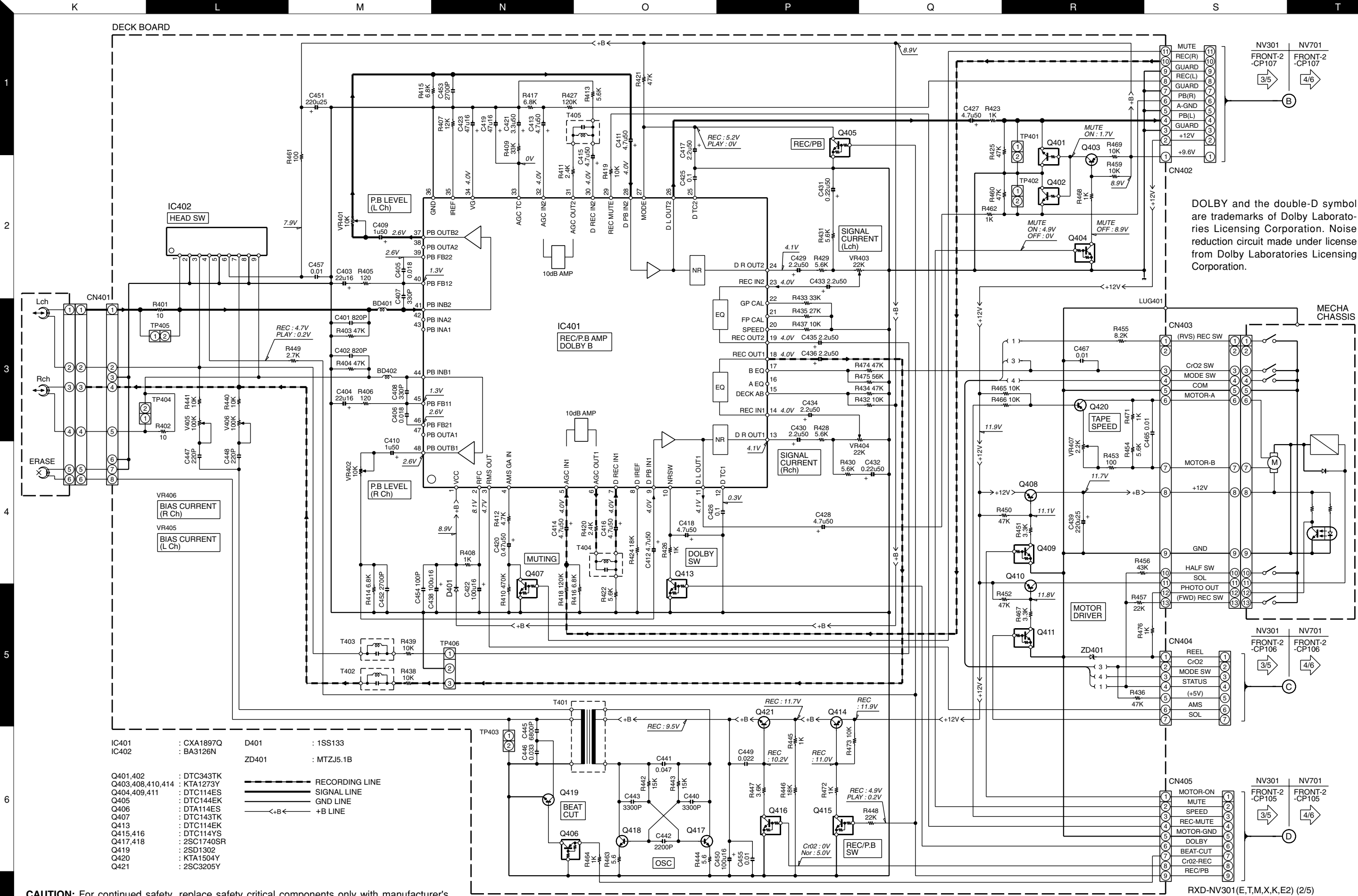

DOLBY and the double-D symbol are trademarks of Dolby Laboratories Licensing Corporation. Noise reduction circuit made under license from Dolby Laboratories Licensing Corporation.

- | | | | |
|-------|------------|-------|------------|
| IC401 | : CXA1897Q | D401 | : 1SS133 |
| IC402 | : BA3126N | ZD401 | : MTZJ5.1B |
-
- | | | | |
|------------------|-------------|------|----------------|
| Q401,402 | : DTC343TK | --- | RECORDING LINE |
| Q403,408,410,414 | : KTA1273Y | --- | SIGNAL LINE |
| Q404,409,411 | : DTC114ES | --- | GND LINE |
| Q405 | : DTC144EK | ←+B← | +B LINE |
| Q406 | : DTA114ES | | |
| Q407 | : DTC143TK | | |
| Q413 | : DTC114EK | | |
| Q415,416 | : DTC114YS | | |
| Q417,418 | : 2SC1740SR | | |
| Q419 | : 2SD1302 | | |
| Q420 | : KTA1504Y | | |
| Q421 | : 2SC3205Y | | |

CAUTION: For continued safety, replace safety critical components only with manufacturer's recommended parts (refer to parts list). Δ indicates safety critical components. For continued protection against risk of fire, replace only with same type and rating fuse(s). To reduce the risk of electric shock, leakage-current or resistance measurements shall be carried out (exposed parts are acceptably insulated from the supply circuit) before the appliance is returned to the customer.

The DC voltage is an actual reading measured with a high impedance type voltmeter with a cassette loaded at playback mode. The measurement value may vary depending on the measuring instruments used or on the product. Bias circuit DC voltage is measured while in the record mode.

Y39-3640-10

RXD-NV301/NV301E/NV701/NV701E

KENWOOD

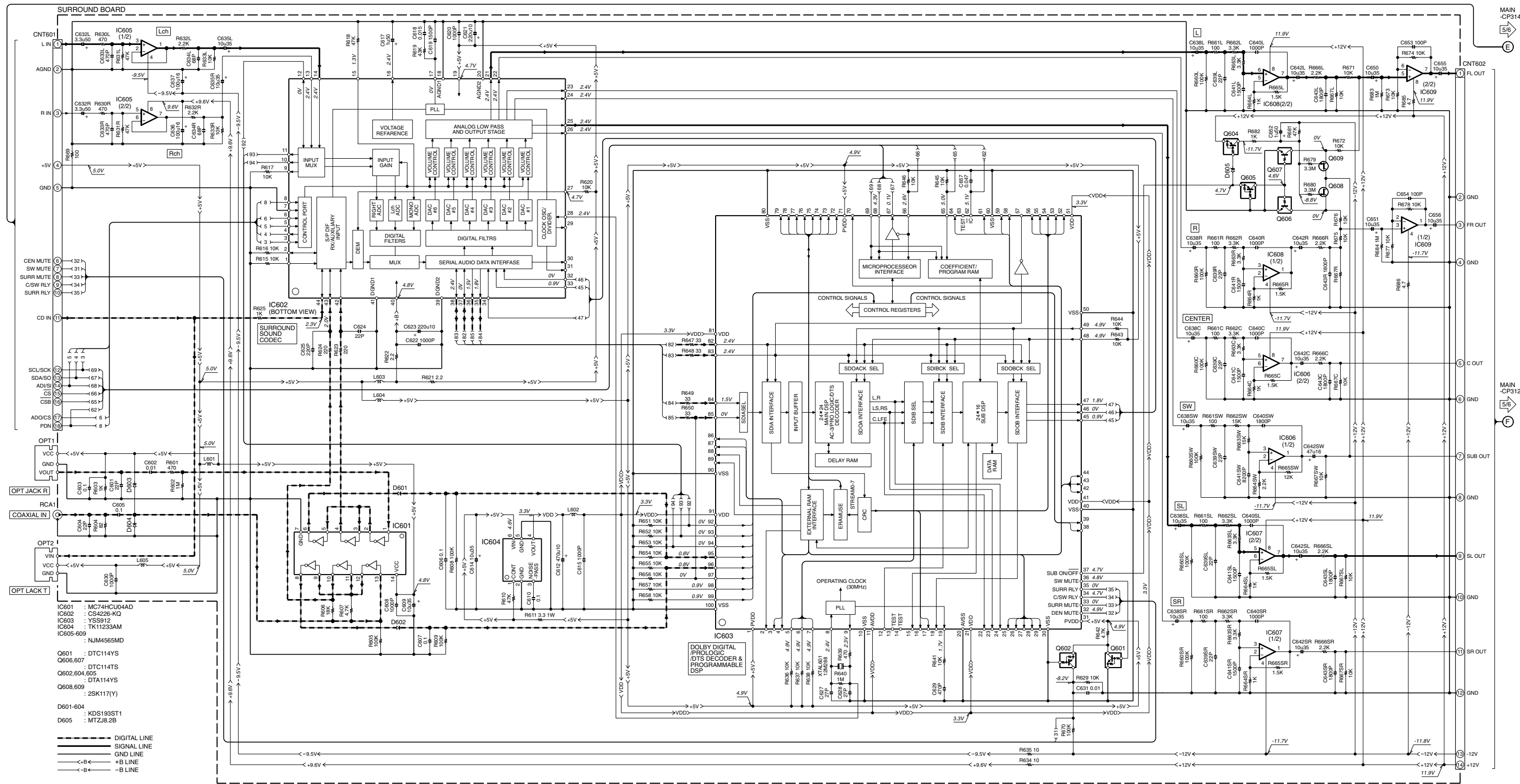

CAUTION: For continued safety, replace safety critical components only with manufacturer's recommended parts (refer to parts list). Δ indicates safety critical components. For continued protection against risk of fire, replace only with same type and rating fuse(s). To reduce the risk of electric shock, leakage-current or resistance measurements shall be carried out (exposed parts are acceptably insulated from the supply circuit) before the appliance is returned to the customer.

The DC voltage is an actual reading measured with a high impedance type voltmeter with a cassette loaded at playback mode. The measurement value may vary depending on the measuring instruments used or on the product. Bias circuit DC voltage is measured while in the record mode.

DOLBY and the double-D symbol are trademarks of Dolby Laboratories Licensing Corporation. Noise reduction circuit made under license from Dolby Laboratories Licensing Corporation.

RXD-NV701/NV701E

KENWOOD

2
3
4
5
6

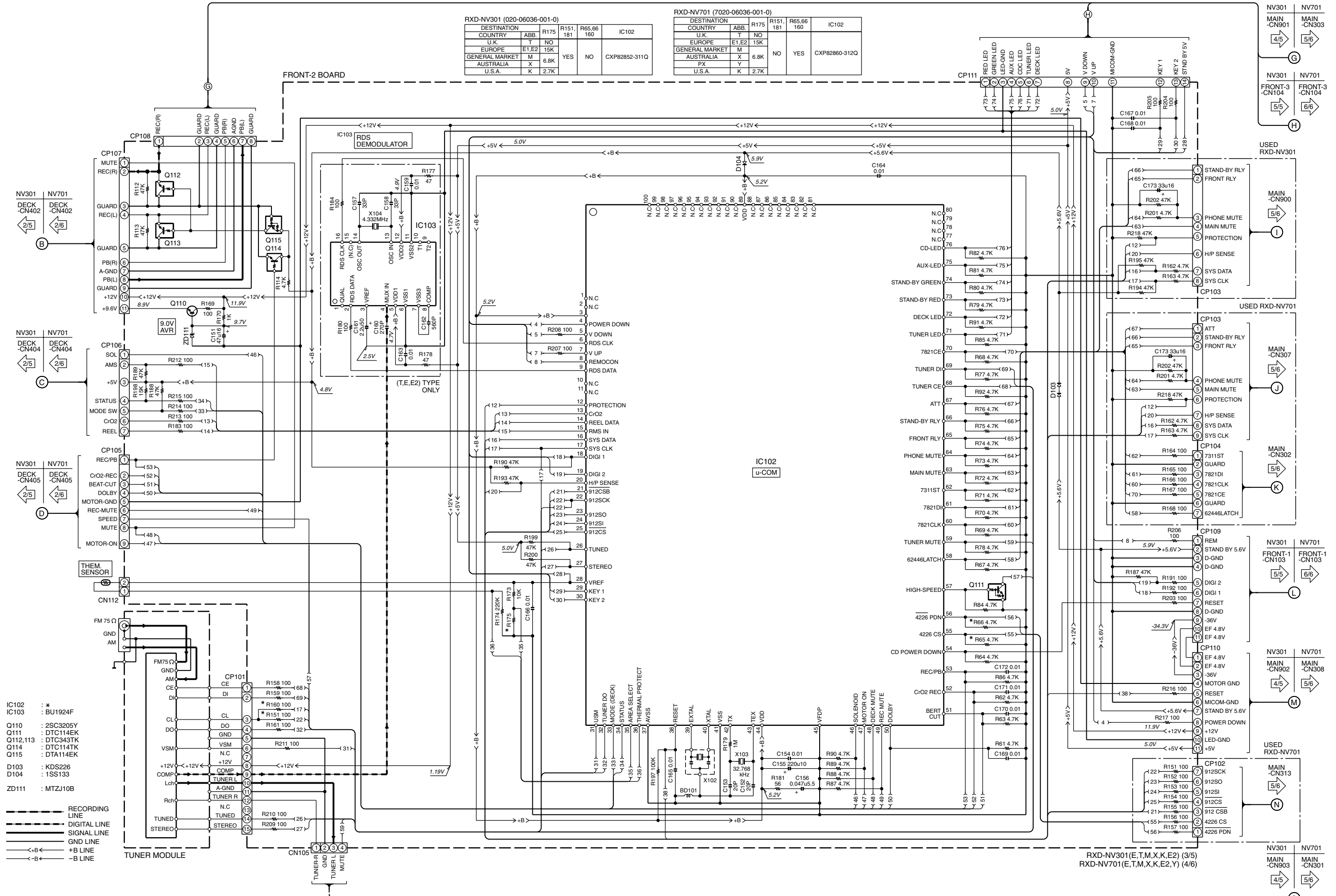

RXD-NV301 (020-06036-001-0)					
DESTINATION	ABB.	R175	R151, 181	R65,66 160	IC102
U.K.	T	NO			
EUROPE	E1,E2	15K			
GENERAL MARKET	M	6.8K	YES	NO	CXP82852-311Q
AUSTRALIA	X	6.8K			
U.S.A.	K	2.7K			

RXD-NV701 (7020-06036-001-0)					
DESTINATION	ABB.	R175	R151, 181	R65,66 160	IC102
U.K.	T	NO			
EUROPE	E1,E2	15K			
GENERAL MARKET	M	6.8K	NO	YES	CXP82860-312Q
AUSTRALIA	X	6.8K			
PX	Y				
U.S.A.	K	2.7K			

- IC102 : *
- IC103 : BU1924F
- Q110 : 2SC3205Y
- Q111 : DTC114EK
- Q112,113 : DTC343TK
- Q114 : DTC114TK
- Q115 : DTA114EK
- D103 : KDS226
- D104 : 1SS133
- ZD111 : MTZJ10B

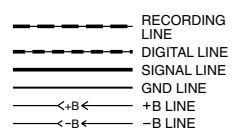

CAUTION: For continued safety, replace safety critical components only with manufacturer's recommended parts (refer to parts list). Δ indicates safety critical components. For continued protection against risk of fire, replace only with same type and rating fuse(s). To reduce the risk of electric shock, leakage-current or resistance measurements shall be carried out (exposed parts are acceptably insulated from the supply circuit) before the appliance is returned to the customer.

The DC voltage is an actual reading measured with a high impedance type voltmeter with no signal input. The measurement value may vary depending on the measuring instruments used or on the product.

Y39-3640-10

RXD-NV301/NV301E/NV701/NV701E

KENWOOD

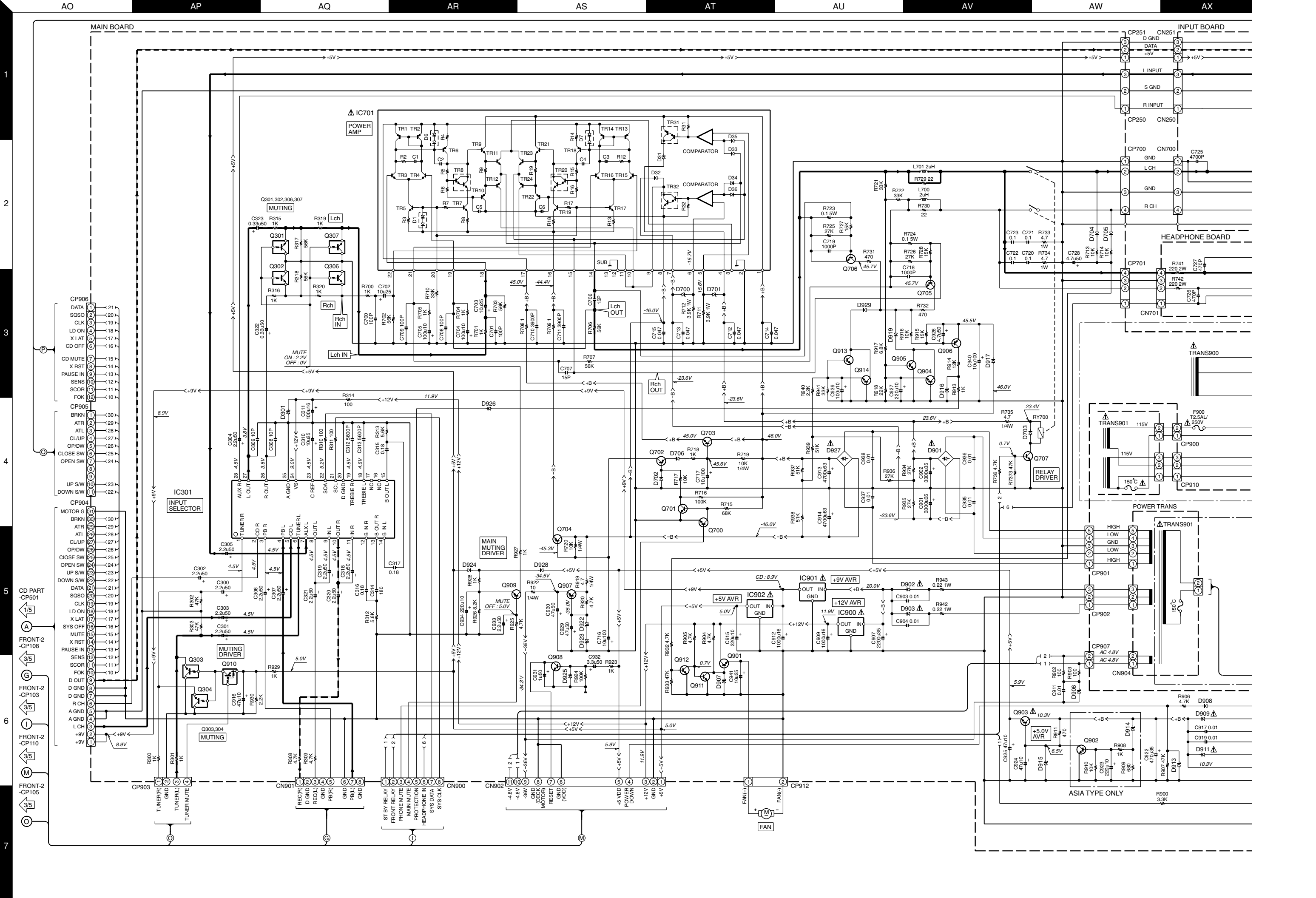

MAIN BOARD

INPUT BOARD

HEADPHONE BOARD

TRANS900

POWER TRANS

ASIA TYPE ONLY

IC701
POWER AMP

IC301
INPUT SELECTOR

MAIN MUTING DRIVER

MUTING DRIVER

MUTING

MUTING

ASIA TYPE ONLY

- CP906: DATA, SOSO, CLK, LD ON, X LAT, CD OFF, CD MUTE, X RST, PAUSE IN, SENS, SCOR, FOK
- CP905: BRKN, ATR, ATL, CLUP, OP/DW, CLOSE SW, OPEN SW, UP SW, DOWN SW
- CP904: MOTOR G, BRKN, ATR, ATL, CLUP, OP/DW, CLOSE SW, OPEN SW, UP SW, DOWN SW
- CD PART -CP501: DATA, SOSO, CLK, LD ON, X LAT, SYS OFF, MUTE, X RST, PAUSE IN, SENS, SCOR, D OUT, D GND, R CH, A GND, L CH
- FRONT-2 -CP108: DATA, SOSO, CLK, LD ON, X LAT, SYS OFF, MUTE, X RST, PAUSE IN, SENS, SCOR, D OUT, D GND, R CH, A GND, L CH
- FRONT-2 -CP103: DATA, SOSO, CLK, LD ON, X LAT, SYS OFF, MUTE, X RST, PAUSE IN, SENS, SCOR, D OUT, D GND, R CH, A GND, L CH
- FRONT-2 -CP110: DATA, SOSO, CLK, LD ON, X LAT, SYS OFF, MUTE, X RST, PAUSE IN, SENS, SCOR, D OUT, D GND, R CH, A GND, L CH
- FRONT-2 -CP105: DATA, SOSO, CLK, LD ON, X LAT, SYS OFF, MUTE, X RST, PAUSE IN, SENS, SCOR, D OUT, D GND, R CH, A GND, L CH

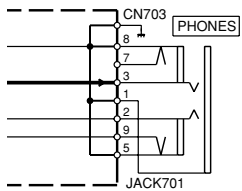
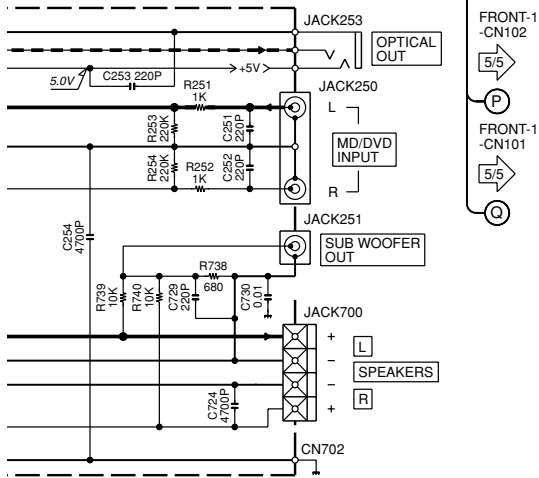

ASIA TYPE ONLY

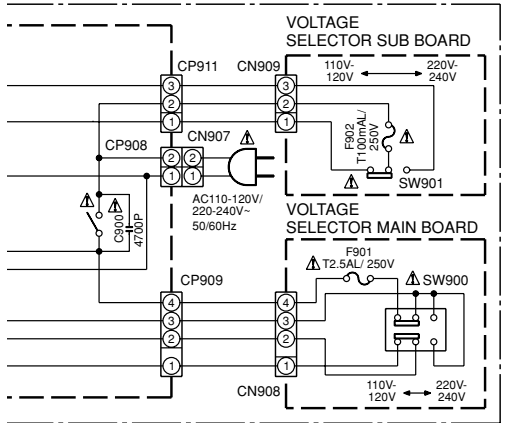

- | | |
|-------------------------|-----------------------|
| IC301 : TDA7440D | D301 : MTZJ9.1B |
| IC701 : STK411-210 | D700.701 : MTZJ8.2B |
| IC900 : NJM7812FA | D702.704-706,908,917, |
| IC901 : NJM7809FA | 919,924-926,928,929 |
| IC902 : NJM7805FA | : 1SS133 |
| | D703,900,902,903 |
| Q301-304,306,307 | 909-912 : IN4007 |
| : DTC343TS | D901,927 : DBF60C |
| Q700,701,705,706 | D906 : MTZJ6.2B |
| : 2SC1845F | D907 : MTZJ10B |
| Q702,704,907 : 2SA916Y | D913,916 : MTZJ5.1B |
| Q703,903 : 2SC3205Y | D914 : MTZJ16B |
| Q707,900-902,904,905, | D915 : MTZJ6.2B |
| 908,911-914 : 2SC1740SR | D922 : MTZJ18B |
| Q906 : 2SA992F | D923 : MTZJ20B |
| Q909 : 2SA933S | |
| Q910 : DTA114ES | |

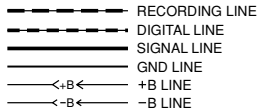

USED U.S.A., EUROPE TYPE

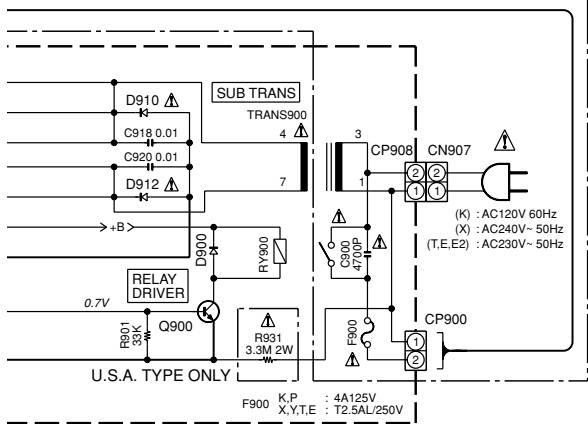

- | | | |
|---------|-----|---------------|
| F900 | K,P | : 4A125V |
| X,Y,T,E | | : T2.5AL/250V |

RXD-NV301(E,T,M,X,K,E2) (4/5)

2SD1302

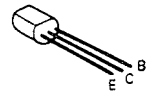

DTA114ES
 DTA114YS
 DTC114ES
 DTC343TS
 2SA933S

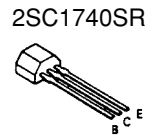

DTA114EK
 DTC114EK
 DTC114TK
 DTC143TK
 DTC144EK

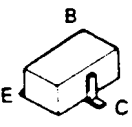

DTC114YS

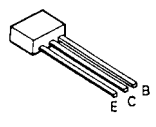

NJM2279D

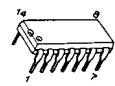

BA3126N

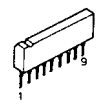

NJM4565MD

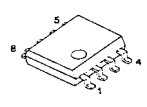

2SK117

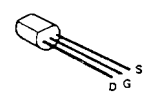

TC74HCT7007AF

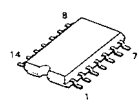

LC7821-IP30P

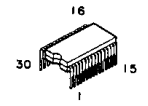

TK11233AM

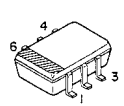

YSS912

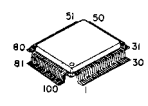

BA5979S

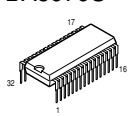

M62446FP

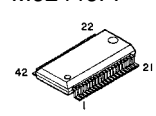

CXA1821M

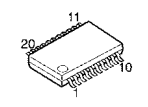

RXD-NV301/NV301E

KENWOOD

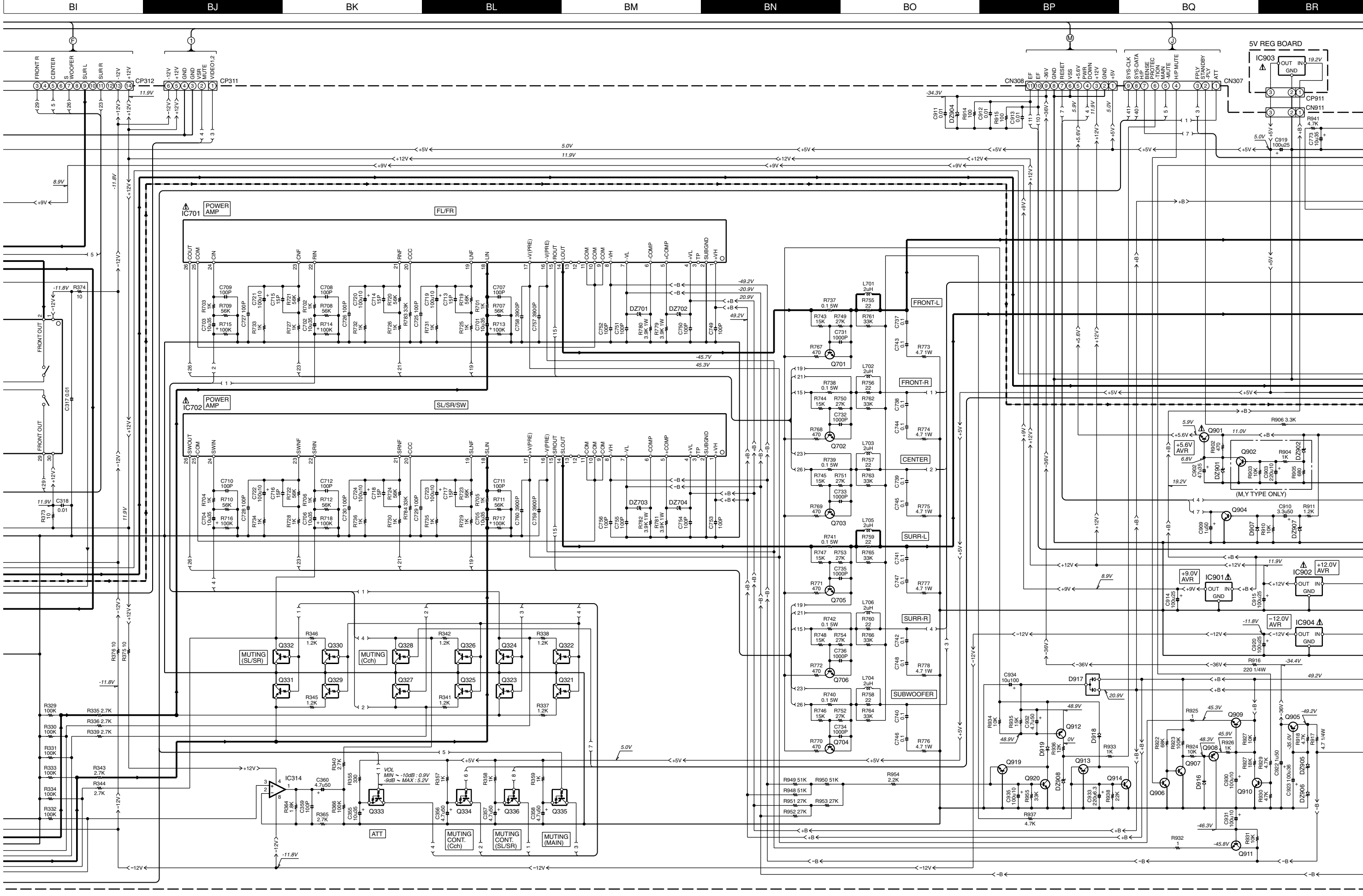

POWER AMP
IC701

FL/FR

POWER AMP
IC702

SL/SR/SW

MUTING (SL/SR)

MUTING (Cch)

ATT

MUTING CONT. (Cch)

MUTING CONT. (SL/SR)

MUTING (MAIN)

FRONT-L

FRONT-R

CENTER

SURR-L

SURR-R

SUBWOOFER

5V REG BOARD

IC903

+5.6V AVR
IC901

+12.0V AVR
IC902

+9.0V AVR
IC903

-12.0V AVR
IC904

+5.6V AVR
IC905

+12.0V AVR
IC906

+9.0V AVR
IC907

-12.0V AVR
IC908

+5.6V AVR
IC909

+12.0V AVR
IC910

+9.0V AVR
IC911

-12.0V AVR
IC912

+5.6V AVR
IC913

+12.0V AVR
IC914

+9.0V AVR
IC915

-12.0V AVR
IC916

+5.6V AVR
IC917

+12.0V AVR
IC918

+9.0V AVR
IC919

-12.0V AVR
IC920

+5.6V AVR
IC921

+12.0V AVR
IC922

+9.0V AVR
IC923

-12.0V AVR
IC924

+5.6V AVR
IC925

+12.0V AVR
IC926

+9.0V AVR
IC927

-12.0V AVR
IC928

+5.6V AVR
IC929

+12.0V AVR
IC930

+9.0V AVR
IC931

-12.0V AVR
IC932

+5.6V AVR
IC933

+12.0V AVR
IC934

+9.0V AVR
IC935

-12.0V AVR
IC936

+5.6V AVR
IC937

+12.0V AVR
IC938

+9.0V AVR
IC939

-12.0V AVR
IC940

+5.6V AVR
IC941

+12.0V AVR
IC942

+9.0V AVR
IC943

-12.0V AVR
IC944

+5.6V AVR
IC945

+12.0V AVR
IC946

+9.0V AVR
IC947

-12.0V AVR
IC948

+5.6V AVR
IC949

+12.0V AVR
IC950

+9.0V AVR
IC951

-12.0V AVR
IC952

+5.6V AVR
IC953

+12.0V AVR
IC954

+9.0V AVR
IC955

-12.0V AVR
IC956

+5.6V AVR
IC957

+12.0V AVR
IC958

+9.0V AVR
IC959

-12.0V AVR
IC960

+5.6V AVR
IC961

+12.0V AVR
IC962

+9.0V AVR
IC963

-12.0V AVR
IC964

+5.6V AVR
IC965

+12.0V AVR
IC966

+9.0V AVR
IC967

-12.0V AVR
IC968

+5.6V AVR
IC969

+12.0V AVR
IC970

+9.0V AVR
IC971

-12.0V AVR
IC972

+5.6V AVR
IC973

+12.0V AVR
IC974

+9.0V AVR
IC975

-12.0V AVR
IC976

+5.6V AVR
IC977

+12.0V AVR
IC978

+9.0V AVR
IC979

-12.0V AVR
IC980

+5.6V AVR
IC981

+12.0V AVR
IC982

+9.0V AVR
IC983

-12.0V AVR
IC984

+5.6V AVR
IC985

+12.0V AVR
IC986

+9.0V AVR
IC987

-12.0V AVR
IC988

+5.6V AVR
IC989

+12.0V AVR
IC990

+9.0V AVR
IC991

-12.0V AVR
IC992

+5.6V AVR
IC993

+12.0V AVR
IC994

+9.0V AVR
IC995

-12.0V AVR
IC996

+5.6V AVR
IC997

+12.0V AVR
IC998

+9.0V AVR
IC999

-12.0V AVR
IC1000

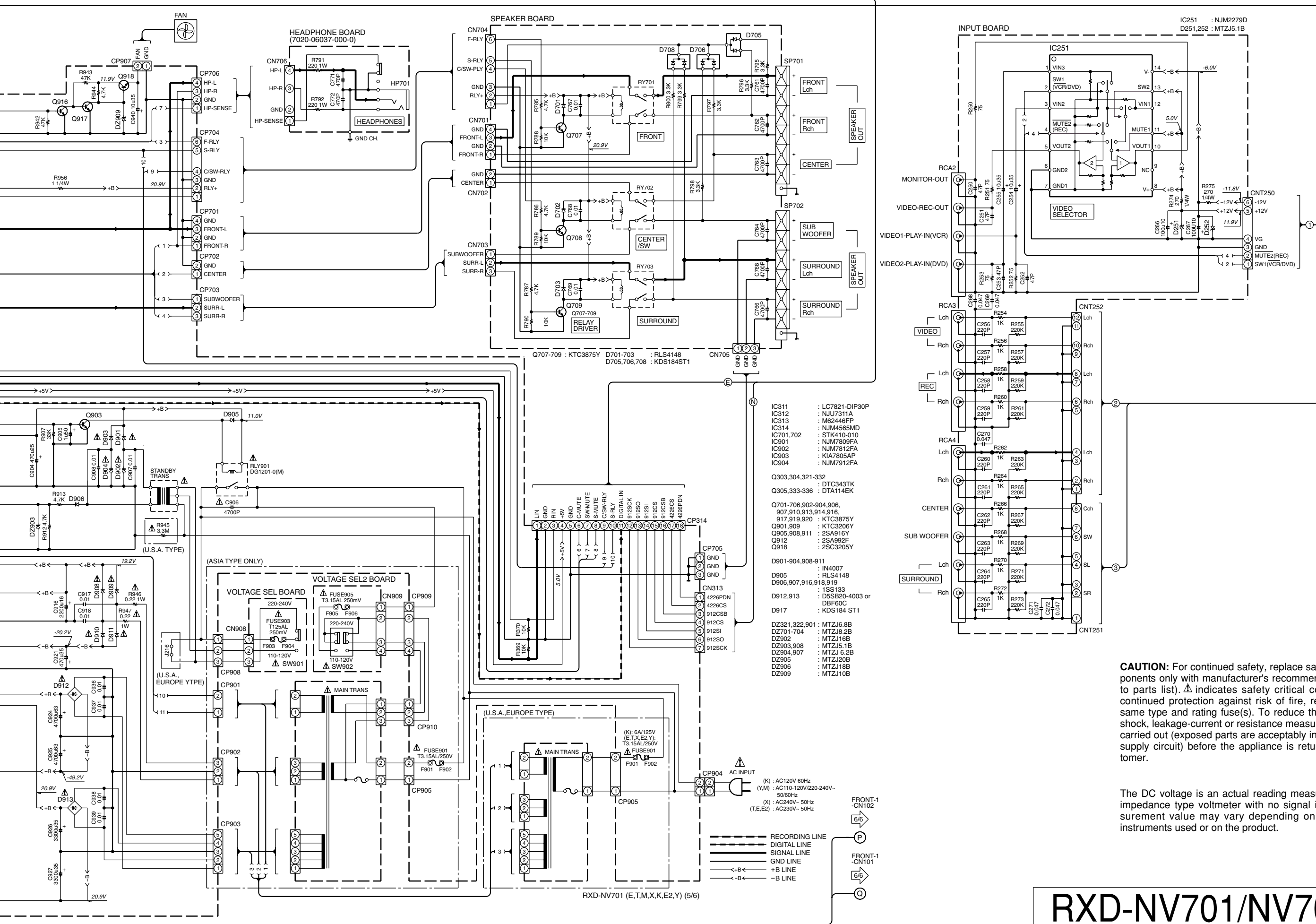

CAUTION: For continued safety, replace safety critical components only with manufacturer's recommended parts (refer to parts list). Δ indicates safety critical components. For continued protection against risk of fire, replace only with same type and rating fuse(s). To reduce the risk of electric shock, leakage-current or resistance measurements shall be carried out (exposed parts are acceptably insulated from the supply circuit) before the appliance is returned to the customer.

The DC voltage is an actual reading measured with a high impedance type voltmeter with no signal input. The measurement value may vary depending on the measuring instruments used or on the product.

RXD-NV701/NV701E

Y39-3640-10

KENWOOD

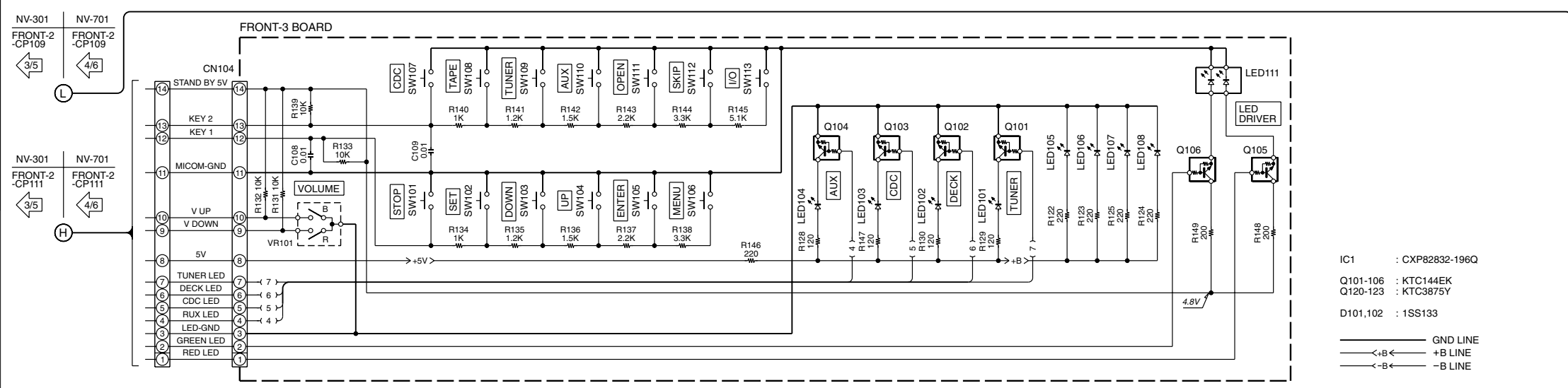

IC1 : CXP82832-196Q
 Q101-106 : KTC144EK
 Q120-123 : KTC3875Y
 D101,102 : 1SS133

— GND LINE
 — +B LINE
 — -B LINE

CAUTION: For continued safety, replace safety critical components only with manufacturer's recommended parts (refer to parts list). Δ indicates safety critical components. For continued protection against risk of fire, replace only with same type and rating fuse(s). To reduce the risk of electric shock, leakage-current or resistance measurements shall be carried out (exposed parts are acceptably insulated from the supply circuit) before the appliance is returned to the customer.

The DC voltage is an actual reading measured with a high impedance type voltmeter with no signal input. The measurement value may vary depending on the measuring instruments used or on the product.

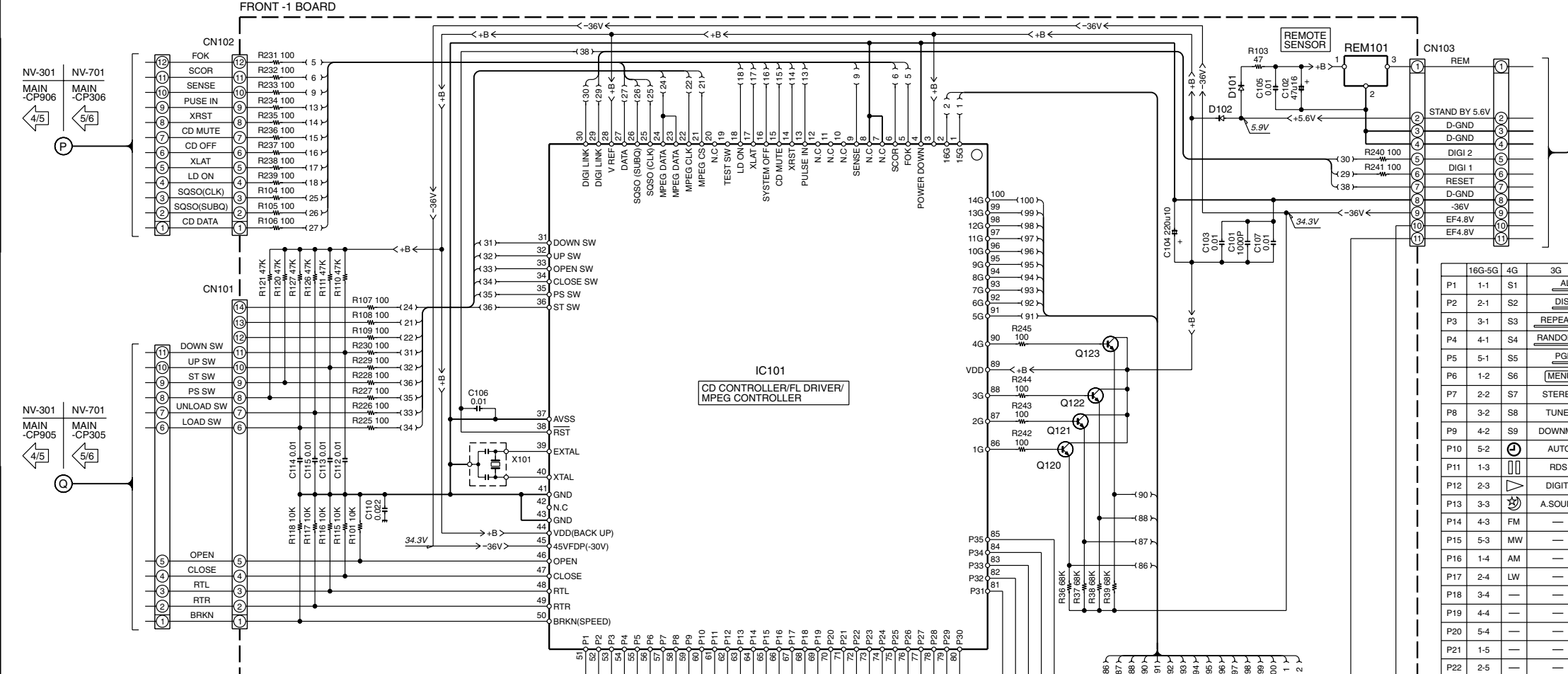

	16G-5G	4G	3G	2G	1G
P1	1-1	S1	ALL	P.B.C.	QR
P2	2-1	S2	DISC	BASS	▶
P3	3-1	S3	REPEAT	VIRTUAL)
P4	4-1	S4	RANDOM	DOLBY DIGITAL	(
P5	5-1	S5	PGM	3	NR
P6	1-2	S6	MENU	STEREO	L
P7	2-2	S7	STEREO	DTS	C
P8	3-2	S8	TUNED	DSP	R
P9	4-2	S9	DOWNMIX	PRO LOGIC	LFE
P10	5-2	⊕	AUTO	—	SW
P11	1-3	▶	RDS	—	LS
P12	2-3	▶	DIGITAL	—	S
P13	3-3	⊕	A.SOUND	—	RS
P14	4-3	FM	—	—	REC
P15	5-3	MW	—	—	▶
P16	1-4	AM	—	—	▶
P17	2-4	LW	—	—	▶
P18	3-4	—	—	—	▶
P19	4-4	—	—	—	▶
P20	5-4	—	—	—	▶
P21	1-5	—	—	—	▶
P22	2-5	—	—	—	▶
P23	3-5	—	—	—	▶
P24	4-5	—	—	—	▶
P25	5-5	—	—	—	▶
P26	1-6	—	—	—	▶
P27	2-6	—	—	—	▶
P28	3-6	—	—	—	▶
P29	4-6	—	—	—	▶
P30	5-6	—	—	—	▶
P31	1-7	—	—	—	▶
P32	2-7	—	—	—	▶
P33	3-7	—	—	—	▶
P34	4-7	—	—	—	▶
P35	5-7	—	—	—	▶

RXD-NV301 (E,T,M,X,K,E2) (5/5)
 RXD-NV701 (E,T,M,X,K,E2,Y) (6/6)

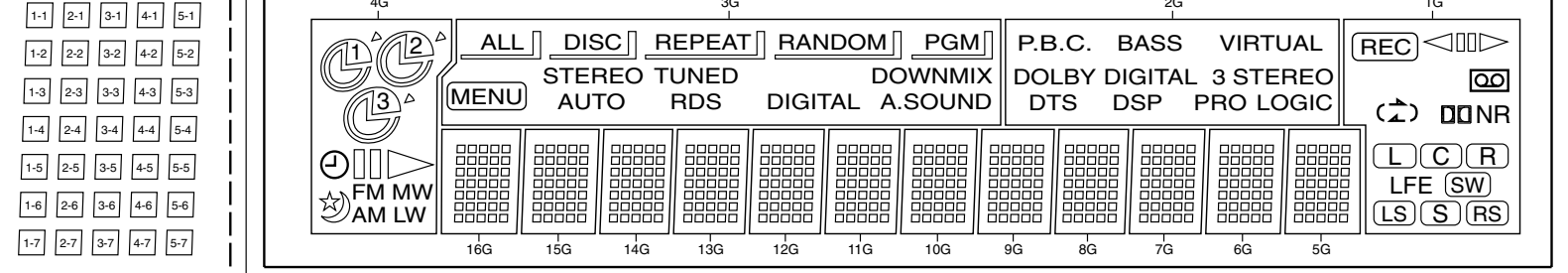
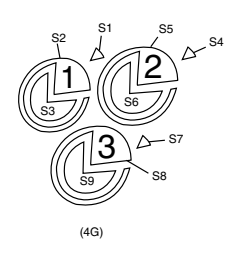

(16G-5G)

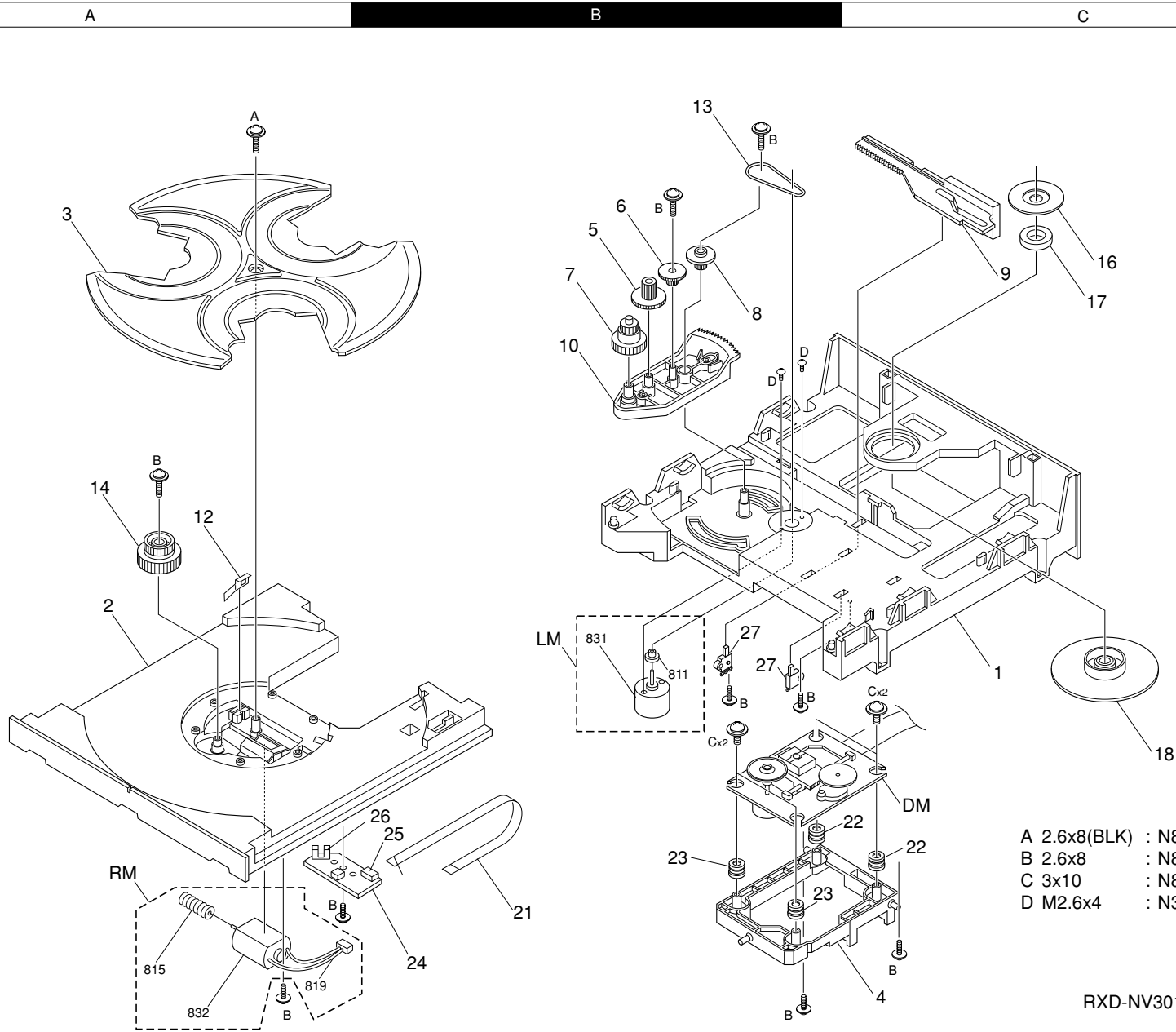

**RXD-NV301/NV301E/NV701/NV701E
EXPLODED VIEW(CD MECHANISM)**

Parts with exploded numbers larger than 700 are not supplied.

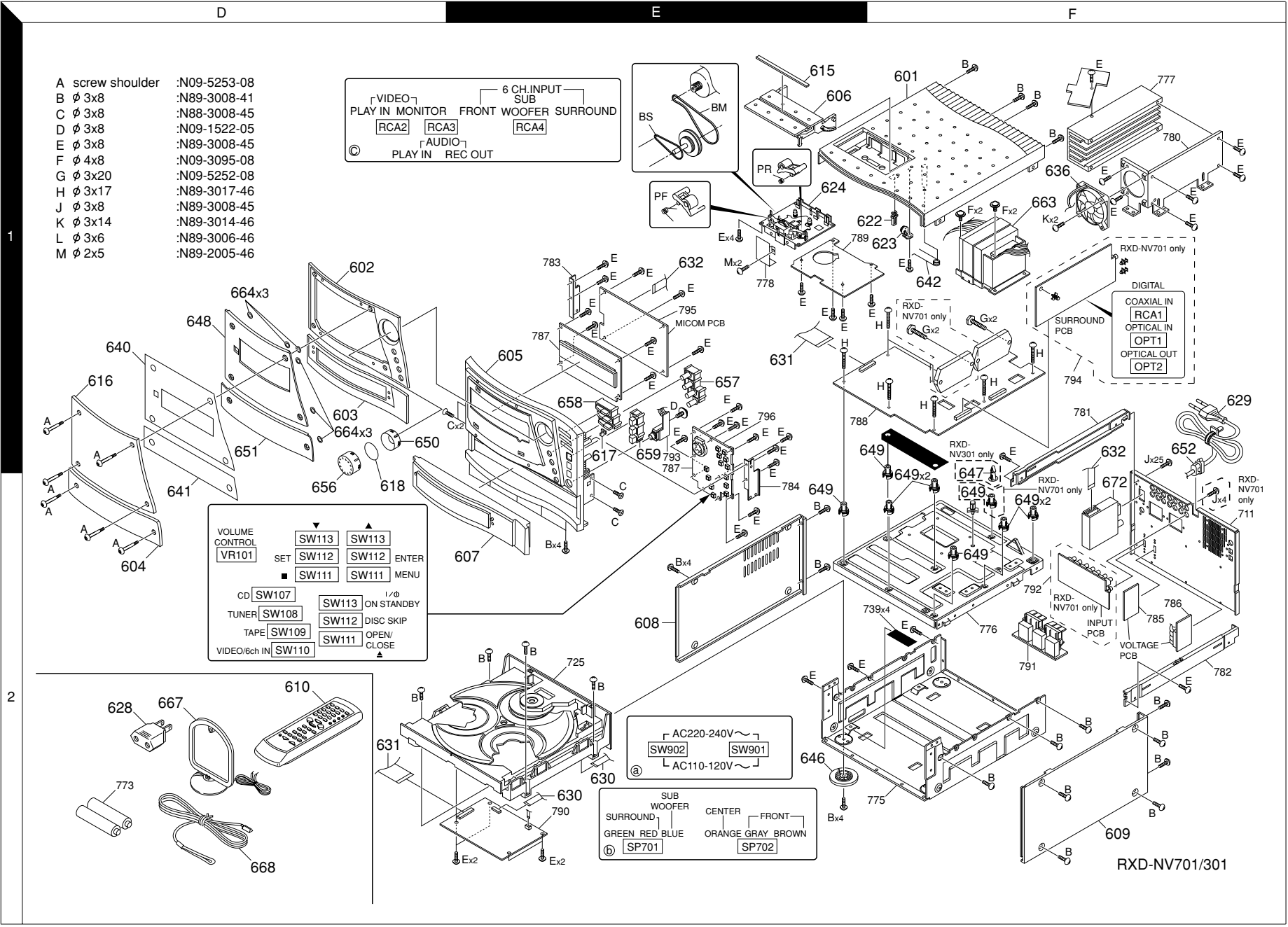

- A screw shoulder :N09-5253-08
- B ϕ 3x8 :N89-3008-41
- C ϕ 3x8 :N88-3008-45
- D ϕ 3x8 :N09-1522-05
- E ϕ 3x8 :N89-3008-45
- F ϕ 4x8 :N09-3095-08
- G ϕ 3x20 :N09-5252-08
- H ϕ 3x17 :N89-3017-46
- J ϕ 3x8 :N89-3008-45
- K ϕ 3x14 :N89-3014-46
- L ϕ 3x6 :N89-3006-46
- M ϕ 2x5 :N89-2005-46

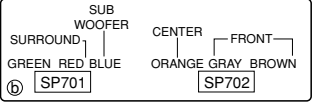
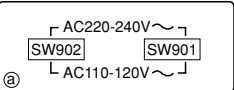
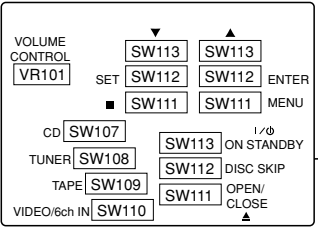
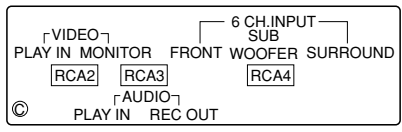

RXD-NV701/301

* New Parts

Parts without **Parts No.** are not supplied.
Les articles non mentionnés dans le **Parts No.** ne sont pas fournis.
Teile ohne **Parts No.** werden nicht geliefert.

①

Ref. No	Add-ress	New Parts	Parts No.	Description	Desti-nation	Re-marks
RXD-NV301/NV301E/NV701/NV701E						
601	1F	*	A02-2994-08	CABINET TOP		
602	1D	*	A21-3910-08	PANEL(BLUE)		3
602	1D	*	A21-3916-08	PANEL(BLUE)		7
603	1D	*	A21-3911-08	PANEL		
604	2D	*	A21-3912-08	PANEL	ET	3
604	2D	*	A21-3913-08	PANEL	MXKE2	3
604	2D	*	A21-3914-08	PANEL	ET	7
604	2D	*	A21-3915-08	PANEL	KMXYE2	7
605	1E	*	A21-3917-08	PANEL(FRONT)	MX	
605	1E	*	A21-3917-08	PANEL(FRONT)	TEE2	
605	1E	*	A21-3918-08	PANEL(FRONT)		
606	1E	*	A53-2232-08	DOOR(DECK)	K	
607	2E	*	A60-1971-08	COVER(TRAY)		
608	2E	*	A50-1391-08	CABINET SIDE L		
609	2F	*	A50-1392-08	CABINET SIDE R		
610	2D	*	A70-1459-08	REMOCON	ETE2	3
610	2D	*	A70-1460-08	REMOCON	ETE2	7
610	2D	*	A70-1461-08	REMOCON	KMXY	7
610	2D	*	A70-1475-08	REMOCON	KMX	3
615	1E	*	B03-3878-08	WINDOW		
616	1D	*	B10-3641-08	PANEL(FG)NV301		3
616	1D	*	B10-3642-08	PANEL(FG)		7
617	1E	*	B11-1518-08	LENS		
618	1D	*	B11-1519-08	FILTER		
-	-	*	B60-4755-08	INST MANUAL(EN)	MX	
-	-	*	B60-4755-08	INST MANUAL(EN)	TE2	
-	-	*	B60-4756-08	INST MANUAL(FR)	E	
-	-	*	B60-4757-08	INST MANUAL(GR)	E	
-	-	*	B60-4758-08	INST MANUAL(IT)	E	
-	-	*	B60-4759-08	INST MANUAL(ES)	E	
-	-	*	B60-4760-08	INST MANUAL(TC)	M	
-	-	*	B60-4761-08	INST MANUAL(AR)	M	
-	-	*	B60-4762-08	INST MANUAL(PO)	E2	
-	-	*	B60-4763-08	INST MANUAL(CH)	E2	
-	-	*	B60-4764-08	INST MANUAL(NE)	E	
-	-	*	B60-4765-08	INST MANUAL(HN)	E2	
-	-	*	B60-4766-08	INST MANUAL(RO)	E2	
622	1F	*	D32-0369-08	LEVER		
623	1F	*	D39-0328-08	GEAR DAMPER		
624	1E	*	D40-1713-08	DECK MECHA		
628	2D	*	E03-0115-05	AC PLUG ADAPTER	M	
629	1F	*	E30-2979-08	AC CORD ASSY	T	
629	2F	*	E30-2980-08	AC CORD ASSY	K	
629	1F	*	E30-2981-08	AC CORD ASSY	EME2Y	
629	1F	*	E30-2982-08	AC CORD ASSY	X	
630	2E	*	E35-2771-08	FCC (16P 150mm)		
631	2D,1E	*	E35-2772-08	FCC (31P 230mm)		
632	1E	*	E35-2773-08	FCC (15P 350mm)		
636	1F	*	F09-0155-08	FAN,DC		
640	1D	*	G16-1217-08	SHEET		
641	1D	*	G16-1218-08	SHEET		

L: Scandinavia K: USA P: Canada R: Mexico C: China I: Malaysia
Y: PX(Far East,Hawaii) T: England E: Europe G: Germany V: China(Shanghai)
Y: AAFES(Europe) X: Australia Q: Russia H: Korea M: Other Areas Δ indicates safety critical components.

* New Parts

Parts without **Parts No.** are not supplied.
Les articles non mentionnés dans le **Parts No.** ne sont pas fournis.
Teile ohne **Parts No.** werden nicht geliefert.

②

Ref. No	Add-ress	New Parts	Parts No.	Description	Desti-nation	Re-marks
642	1F	*	G02-1722-08	SPRING		
-	-	*	H10-7734-08	CUSHION,SNOW		
-	-	*	H25-1601-08	POLY BAG(260X390)		
-	-	*	H25-1677-08	POLY BAG(SET)		
-	-	*	H50-3888-08	BOX,GIFT	KX	3
-	-	*	H50-3889-08	BOX,GIFT	M	3
-	-	*	H50-3890-08	BOX,GIFT	T	3
-	-	*	H50-3891-08	BOX,GIFT	KXY	7
-	-	*	H50-3892-08	BOX,GIFT	M	7
-	-	*	H50-3893-08	BOX,GIFT	T	7
-	-	*	H50-3913-08	BOX,GIFT	E	3
-	-	*	H50-3914-08	BOX,GIFT	E2	3
-	-	*	H50-3915-08	BOX,GIFT	E	7
-	-	*	H50-3916-08	BOX,GIFT	E2	7
646	2E	*	J02-1506-08	FOOT ASSY		
647	2F	*	J19-6159-08	HOLDER		3
648	1D	*	J19-6160-08	SUPPORT		
649	2E,2F	*	J19-6161-08	UNIT HOLDER		
650	1D	*	J19-6162-08	INSERT(MULTIkey)		
651	1D	*	J19-6167-08	SUPPORTER		
652	1F	*	J42-0083-05	AC CORD BUSHING		
656	2D	*	K29-7901-08	KNOB		
657	1E	*	K29-7902-08	BUTTON		
658	1E	*	K29-7903-08	BUTTON		
659	1E	*	K29-7904-08	BUTTON		
Δ 663	1F	*	L07-2953-08	TRANS901	ETE2	3
Δ 663	1F	*	L07-2954-08	TRANS901	K	3
Δ 663	1F	*	L07-2955-08	TRANS901	M	3
Δ 663	1F	*	L07-2956-08	TRANS901	X	3
Δ 663	1F	*	L07-2957-08	MAIN TRANS	ETE2	7
Δ 663	1F	*	L07-2958-08	MAIN TRANS	K	7
Δ 663	1F	*	L07-2959-08	MAIN TRANS	MY	7
Δ 663	1F	*	L07-2960-08	MAIN TRANS	X	7
664	1D	*	N19-1515-08	SHEET WASHER		
A	*		N09-5253-08	SCREW(FRONT)		
F	*		N09-3095-08	SCREW 4X8 WASHER		
G	*		N09-5252-08	SCREW 3X20 HEX		
667	2D	*	T90-0804-08	ANTENNA,LOOP		
668	2D	*	T90-0830-08	ANTENNA,WIRE		
672	2F	*	W02-2789-08	TUNER,FM/AM		
672	2F	*	W02-2790-08	TUNER,FM/AM		
672	2F	*	W02-2791-08	TUNER,FM/AM		
672	2F	*	W02-2792-08	TUNER,FM/AM		
MAIN BOARD (RXD-NV301)						
C251-253			CC45FSL1H221J	CERAMIC	220PF	J
C254			CK45FB1H473Z	CERAMIC	0.047UF	Z
C300-307			CE04KW1H2R2M	ELECTRO	2.2UF	50WV
C308,309			CC45FSL1H100D	CERAMIC	10PF	D
C310			CE04KW1E100M	ELECTRO	10UF	25WV
C311			CE04KW1C101M	ELECTRO	100UF	16WV
C312,313			CQ92FM1H562J	MYLAR	5600PF	J
C314-317		*	C91-1604-08	MF	0.18UF	J

L: Scandinavia K: USA P: Canada R: Mexico C: China I: Malaysia
Y: PX(Far East,Hawaii) T: England E: Europe G: Germany V: China(Shanghai)
Y: AAFES(Europe) X: Australia Q: Russia H: Korea M: Other Areas Δ indicates safety critical components.

PARTS LIST

RXD-NV301/NV301E/NV701/NV701E

* New Parts
Parts without **Parts No.** are not supplied.
Les articles non mentionnés dans le **Parts No.** ne sont pas fournis.
Teile ohne **Parts No.** werden nicht geliefert.

③

Ref. No	Add-ress	New Parts	Parts No.	Description	Desti-nation	Re-marks
C318-321 C322,323 C700,701 C702,703 C704,705			CE04KW1H2R2M CE04KW1HR33M CC45FSL1H101J CE04KW1E100M CE04KW1A101M	ELECTRO 2.2UF 50WV ELECTRO 0.33UF 50WV CERAMIC 100PF J ELECTRO 10UF 25WV ELECTRO 100UF 10WV		
C706,707 C708,709 C710,711 C712-715 C716,717			CC45FSL1H150J CC45FSL1H101J CK45FB1H392K CK45FB1H473Z CE04KW2A100M	CERAMIC 15PF J CERAMIC 100PF J CERAMIC 3900PF K CERAMIC 0.047UF Z ELECTRO 10UF 100WV		
C718,719 C720-723 C724,725 C726,727 C728		*	CK45FB1H102K C91-1605-08 CQ92FM1H472J CC45FSL1H471J CE04KW1H477M	CERAMIC 1000PF K MYLAR 0.1F J MYLAR 4700PF J CERAMIC 470PF J ELECTRO 4.7UF 50WV		
C729 C730 C900 C901,902 C903,904		*	CC45FSL1H221J CK45FB1H103Z C91-1606-08 CE04KW1V332M CK45FB1H103K	CERAMIC 220PF J CERAMIC 0.010UF Z CERAMIC 4700PF J ELECTRO 3300UF 35WV CERAMIC 0.010UF K		
C907 C909 C911 C912 C913,914			CE04KW1V222M CE04KW1C102M CK45FB1H103K CE04KW1C102M CE04KW1J472M	ELECTRO 2200UF 35WV ELECTRO 1000UF 16WV CERAMIC 0.010UF K ELECTRO 1000UF 16WV ELECTRO 4700UF 63WV		
C915 C916 C917-920 C922 C923			CE04KW1A221M CE04KW1A470M CK45FB1H103K CE04KW1V471M CE04KW1A221M	ELECTRO 220UF 10WV ELECTRO 47UF 10WV CERAMIC 0.010UF K ELECTRO 470UF 35WV ELECTRO 220UF 10WV	M	
C924,925 C926 C927 C929,930 C931			CE04KW1A470M CE04KW1H4R7M CE04KW1A221M CE04KW1H470M CE04KW1H010M	ELECTRO 47UF 10WV ELECTRO 4.7UF 50WV ELECTRO 220UF 10WV ELECTRO 47UF 50WV ELECTRO 1.0UF 50WV		
C932 C933 C934 C935-938 C939			CE04KW1H3R3M CE04KW1H2R2M CE04KW1A221M CK45FB1H103K CE04KW1A101M	ELECTRO 3.3UF 50WV ELECTRO 2.2UF 50WV ELECTRO 220UF 10WV CERAMIC 0.010UF K ELECTRO 100UF 10WV		
C940 C941			CE04KW2A100M CE04KW1E100M	ELECTRO 10UF 100WV ELECTRO 10UF 25WV		
CP904 JACK250 JACK251 JACK253 JACK700		*	E40-8743-08 E63-0189-08 E63-1181-08 W02-2800-08 E70-0137-08	CN FFC 1.25MM31P L131120310020 TER,RCA 2PIN G601020044000 TER,RCA 1PIN SUPER WOOFER MODULE(OPTI OUT) E100155100010 TER,BOARD PUSH SPEAKER		
JACK701			E11-0908-08	JACK,D6.5 HEADPH G402207800500		
F900 F900 F901 F902			F50-0166-08 F50-0166-08 F50-0166-08 F05-1014-05	FUSE(250V T2.5A) G650252251160 FUSE(250V T2.5A) G650252251160 FUSE(250V T2.5A) G650252251160 FUSE(250V 100MA) G650101251160	KMX TEE2 M M	
F900A			J13-0084-08	HOLDER,FUSE G645000050010		

L : Scandinavia K : USA P : Canada R : Mexico C : China I : Malaysia
Y : PX(Far East,Hawaii) T : England E : Europe G : Germany V : China(Shanghai)
Y : AAFES(Europe) X : Australia Q : Russia H : Korea M : Other Areas ⚠ indicates safety critical components .

* New Parts
Parts without **Parts No.** are not supplied.
Les articles non mentionnés dans le **Parts No.** ne sont pas fournis.
Teile ohne **Parts No.** werden nicht geliefert.

④

Ref. No	Add-ress	New Parts	Parts No.	Description	Desti-nation	Re-marks
F900B			J13-0084-08	HOLDER,FUSE G645000050010		
L700,701 TRANS900 TRANS900 TRANS900 TRANS900			L39-1387-08 L07-1983-08 L07-1987-08 L07-2972-08 L07-2973-08	COIL,INDUCTOR D310200000000 STANBY TRANS 8200280001000 STANBY TRANS 8200280004000 STANBY TRANS 8200280690010 STANBY TRANS 8200350150020		X TEE2 K M
R36 -39 R72 -75 R711,712 R719,720 R723,724			RK73FB2A683J RK73FB2A472J RS14GB3A392J RN14BK2E1002F R92-1936-08	CHIP R 68K J 1/10W CHIP R 4.7K J 1/10W FL-PROOF RS 3.9K J 1W RN 10,0K F 1/4W CEMENT R 0.1 J 5W		
R733,734 R735 R741,742 R919 R922			RS14GB3A4R7J RN14BK2E4R70F RS14GB3D221J RD14GB2E4R7J RN14BK2E10R0F	FL-PROOF RS 4.7 J 1W RN 4.70 F 1/4W FL-PROOF RS 220 J 2W FL-PROOF RD 4.7 J 1/4W RN 10 F 1/4W		
R931 R942,943		*	R92-1980-08 R92-1979-08	METAL R 3.3M J 2W METAL R 0.22 J 1W		K
RY700 RY900 SW900 SW901		*	S76-0076-05 S76-0104-08 S62-0098-08 S62-0099-08	RELAY G680242000000 RELAY G680000130020 SLIDE SW G060040550010 SLIDE SW G060040540010		M M
D301 D700,701 D702 D703 D704-706		*	MTZJ9.1B MTZJ8.2B 1SS133 IN4007 1SS133	D,ZENER D,ZENER D,SWITCHING D,SWITCHING D,SWITCHING		
D900 D901 D901 D902,903 D906		*	IN4007 DBF60C D5SB20-4003 IN4007 MTZJ6.2B	D,SWITCHING D,RECTIFIER BRI D,RECTIFIER BRI D,SWITCHING D,ZENER		
D907 D908 D909-912 D913 D914		*	MTZJ10B 1SS133 IN4007 MTZJ5.1B MTZJ16B	D,ZENER D,SWITCHING D,SWITCHING D,ZENER D,ZENER		M
D915 D916 D917 D919 D922			MTZJ6.2B MTZJ5.1B 1SS133 1SS133 MTZJ18B	D,ZENER D,ZENER D,SWITCHING D,SWITCHING D,ZENER		
D923 D924-926 D927 D927 D928,929		*	MTZJ20B 1SS133 DBF60C D5SB20-4003 1SS133	D,ZENER D,SWITCHING D,RECTIFIER D,RECTIFIER D,SWITCHING		
IC301 IC701 IC900 IC901 IC902			TDA7440D STK411-210 NJM7812FA NJM7809FA NJM7805FA	IC,LINEAR EQ IC,LINEAR POWER IC(VOLTAGE REGULATOR/ +12V)16W IC,LINEAR-REGUL NJM7809FA,20W IC(VOLTAGE REGULATOR)805FA,16W		
Q301-304			DTC343TS	SEMI,BRT/NPN RC		

L : Scandinavia K : USA P : Canada R : Mexico C : China I : Malaysia
Y : PX(Far East,Hawaii) T : England E : Europe G : Germany V : China(Shanghai)
Y : AAFES(Europe) X : Australia Q : Russia H : Korea M : Other Areas ⚠ indicates safety critical components .

* New Parts

Parts without **Parts No.** are not supplied.
Les articles non mentionnés dans le **Parts No.** ne sont pas fournis.
Teile ohne **Parts No.** werden nicht geliefert.

5

Ref. No	Add-ress	New Parts	Parts No.	Description	Desti-nation	Re-marks
Q306,307 Q700,701 Q702 Q703 Q704			DTC343TS 2SC1845F 2SA916Y 2SC3205Y 2SA916Y	SEMI,BRT/NPN RC SEMI,TR/GE NPN SEMI,TR/GE PNP SEMI,TR/GE NPN SEMI,TR/GE PNP		KTC3205Y KSA916Y
Q705,706 Q707 Q900,901 Q902 Q903			2SC1845F 2SC1740SR 2SC1740SR 2SC1740SR 2SC3205Y	SEMI,TR/GE NPN SEMI,TR/GE NPN SEMI,TR/GE NPN SEMI,TR/GE NPN SEMI,TR/GE NPN	M	KSC1845F
Q904,905 Q906 Q907 Q908 Q909			2SC1740SR 2SA992F 2SA916Y 2SC1740SR 2SA933S	SEMI,TR/GE NPN SEMI,TR/GE PNP SEMI,TR/GE PNP SEMI,TR/GE NPN SEMI,TR/GE PNP		KSA992F KSA916Y
Q910 Q911-914			DTA114ES 2SC1740SR	SEMI,BRT/PNP RA SEMI,TR/GE NPN		
MAIN BOARD (RXD-NV701)						
C314 C315 C316 C317,318 C319			CC73FSL1H101J CK73FB1H103K CK73FB1H223K CK73FB1H103K CK73FSL1H101J	CHIP C CHIP C CHIP C CHIP C CHIP C		100PF J 0.010UF K 0.022UF K 0.010UF K 100PF J
C321,322 C323,324 C325,326 C327,328 C329,330			CE04KW1HR33M CK73FB1H153K CK73FB1H822K CE04KW1H3R3M CE04KW1H4R7M	ELECTRO CHIP C CHIP C ELECTRO ELECTRO		0.33UF 50WV 0.015UF K 8200PF K 3.3UF 50WV 4.7UF 50WV
C331,332 C333,334 C335,336 C337,338 C339			CC73FSL1H101J CE04KW1H4R7M CC73FSL1H101J CE04KW1H4R7M CC73FSL1H101J	CHIP C ELECTRO CHIP C ELECTRO CHIP C		100PF J 4.7UF 50WV 100PF J 4.7UF 50WV 100PF J
C341-348 C349 C350,351 C352 C353			CE04KW1H4R7M CE04KW1A221M CC73FSL1H101J CC73FSL1H221J CE04KW1V100M	ELECTRO ELECTRO CHIP C CHIP C ELECTRO		4.7UF 50WV 220UF 10WV 100PF J 220PF J 10UF 35WV
C354 C355 C356-358 C359 C360			CE04KW1H010M CE04KW1V100M CE04KW1H4R7M CC73FSL1H101J CE04KW1H4R7M	ELECTRO ELECTRO ELECTRO CHIP C ELECTRO		1.0UF 50WV 10UF 35WV 4.7UF 50WV 100PF J 4.7UF 50WV
C701-706 C707-712 C713-718 C719-724 C725-730			CE04KW1V100M CC73FSL1H101J CC45FSL1H150J CE04KW1A101M CC73FSL1H101J	ELECTRO CHIP C CERAMIC ELECTRO CHIP C		10UF 35WV 100PF J 15PF J 100UF 10WV 100PF J
C731-736 C737-748 C749-756 C757-760 C761-766			CC73FSL1H102J CK73FB1H104K CC73FSL1H101J CK45FB1H392K CK45FB1H472K	CHIP C CHIP C CHIP C CERAMIC CERAMIC		1000PF J 0.10UF K 100PF J 3900PF K 4700PF K
C767-769			CK73FB1H103K	CHIP C		0.010UF K

L : Scandinavia K : USA P : Canada R : Mexico C : China I : Malaysia
Y : PX(Far East,Hawaii) T : England E : Europe G : Germany V : China(Shanghai)
Y : AAFES(Europe) X : Australia Q : Russia H : Korea M : Other Areas Δ indicates safety critical components.

* New Parts

Parts without **Parts No.** are not supplied.
Les articles non mentionnés dans le **Parts No.** ne sont pas fournis.
Teile ohne **Parts No.** werden nicht geliefert.

6

Ref. No	Add-ress	New Parts	Parts No.	Description	Desti-nation	Re-marks
C771,772 C773 C902 C903 C904			CC73FSL1H471J CE04KW1V100M CE04KW1V470M CE04KW1A221M CE04KW1E471M	CHIP C ELECTRO ELECTRO ELECTRO ELECTRO		470PF J 10UF 35WV 47UF 35WV 220UF 10WV 470UF 25WV
Δ C905 C906 C907,908 C909 C910			CE04KW1H010M C91-1571-08 CK45FB2H103Z CE04KW1H010M CE04KW1H3R3M	ELECTRO CERAMIC CERAMIC ELECTRO ELECTRO		1.0UF 50WV 0.0047UF 250VAC 0.010UF Z 1.0UF 50WV 3.3UF 50WV
C911-913 C914,915 C916 C917,918 C919,920			CK73FB1H103K CE04KW1E101M CE04KW1V222M CK45FB2H103Z CE04KW1E101M	CHIP C ELECTRO ELECTRO CERAMIC ELECTRO		0.010UF K 100UF 25WV 2200UF 35WV 0.010UF Z 100UF 25WV
C921 C922 C923 C924,925 C926,927			CE04KW1V471M CE04KW1H010M CE04KW1V101M CE04KW1J472M CE04KW1V332M	ELECTRO ELECTRO ELECTRO ELECTRO ELECTRO		470UF 35WV 1.0UF 50WV 100UF 35WV 4700UF 63WV 3300UF 35WV
C930,931 C932 C933 C934 C935			CE04KW2A100M CE04KW1H4R7M CE04KW0J221M CE04KW2A100M CE04KW1A101M	ELECTRO ELECTRO ELECTRO ELECTRO ELECTRO		10UF 100WV 4.7UF 50WV 220UF 6.3WV 10UF 100WV 100UF 10WV
C936-939 C940			CK45FB2H103Z CE04KW1V100M	CERAMIC ELECTRO		0.010UF Z 10UF 35WV
CP304 HP701 SP701,702		*	E40-8743-08 E11-0908-08 E70-0136-08	FCC CONNECTOR31P JACK,D6.5 LOCK TERMINAL 6P		L131120310020 G402207800500 G596040340000
F901,902 F903-906 Δ FUSE901 Δ FUSE901 Δ FUSE901			J13-0084-08 J13-0084-08 F05-3121-05 F05-3121-05 F50-0075-05	HOLDER,FUSE HOLDER,FUSE FUSE(250V 3.15A) FUSE(250V 3.15A) FUSE(125V 6A)		G645000050010 G645000050010 G650312251160 G650312251160 G650602121150
Δ FUSE903 Δ FUSE905		*	F06-1211-05 F05-3121-05	FUSE(250V 125MA) FUSE(250V 3.15A)		G650121251160 G650312251160
Δ L701-706 Δ STBTRANS Δ STBTRANS Δ STBTRANS Δ STBTRANS			L39-1387-08 L07-1983-08 L07-1987-08 L07-2972-08 L07-2973-08	COIL,INDUCTOR 2UH POWER TRANS POWER TRANS POWER TRANS POWER TRANS		D310200000000 8200280001000 8200280004000 8200280960010 8200350150020
J901-912 J909 J951,952 R303,304 R305,306			RK73FB2A000J RK73FB2A000J RK73FB2A000J RK73FB2A152J RK73FB2A104J	CHIP R CHIP R CHIP R CHIP R CHIP R		0 J 1/10W 0 J 1/10W 0 J 1/10W 1.5K J 1/10W 100K J 1/10W
R311 R312 R321,322 R323-328 R329-334			RK73FB2A684J RK73FB2A103J RK73FB2A102J RK73FB2A224J RK73FB2A104J	CHIP R CHIP R CHIP R CHIP R CHIP R		680K J 1/10W 10K J 1/10W 1.0K J 1/10W 220K J 1/10W 100K J 1/10W
R335			RK73FB2A272J	CHIP R		2.7K J 1/10W

L : Scandinavia K : USA P : Canada R : Mexico C : China I : Malaysia
Y : PX(Far East,Hawaii) T : England E : Europe G : Germany V : China(Shanghai)
Y : AAFES(Europe) X : Australia Q : Russia H : Korea M : Other Areas Δ indicates safety critical components.

PARTS LIST

RXD-NV301/NV301E/NV701/NV701E

* New Parts

Parts without **Parts No.** are not supplied.Les articles non mentionnés dans le **Parts No.** ne sont pas fournis.Teile ohne **Parts No.** werden nicht geliefert.

7

Ref. No	Add-ress	New Parts	Parts No.	Description	Quantity	Unit	Desti-nation	Re-marks
R337,338			RK73FB2A122J	CHIP R	1.2K	J	1/10W	
R340			RK73FB2A272J	CHIP R	2.7K	J	1/10W	
R341,342			RK73FB2A122J	CHIP R	1.2K	J	1/10W	
R344			RK73FB2A272J	CHIP R	2.7K	J	1/10W	
R345,346			RK73FB2A122J	CHIP R	1.2K	J	1/10W	
R350,351			RK73FB2A473J	CHIP R	47K	J	1/10W	
R354			RK73FB2A272J	CHIP R	2.7K	J	1/10W	
R355			RK73FB2A331J	CHIP R	330	J	1/10W	
R357-359			RK73FB2A102J	CHIP R	1.0K	J	1/10W	
R361			RK73FB2A101J	CHIP R	100	J	1/10W	
R364			RK73FB2A182J	CHIP R	1.8K	J	1/10W	
R366			RK73FB2A104J	CHIP R	100K	J	1/10W	
R367,368			RK73FB2A472J	CHIP R	4.7K	J	1/10W	
R369,370			RK73FB2A103J	CHIP R	10K	J	1/10W	
R371-376			RK73FB2A100J	CHIP R	10	J	1/10W	
R701-706			RK73FB2A102J	CHIP R	1.0K	J	1/10W	
R707-712			RK73FB2A563J	CHIP R	56K	J	1/10W	
R713-718			RK73FB2A104J	CHIP R	100K	J	1/10W	
R719-724			RK73FB2A563J	CHIP R	56K	J	1/10W	
R727,728			RK73FB2A102J	CHIP R	1.0K	J	1/10W	
R731-736			RK73FB2A102J	CHIP R	1.0K	J	1/10W	
R737-742			R92-1936-08	CEMENT R	0.1	J	5W	
R743-748			RK73FB2A153J	CHIP R	15K	J	1/10W	
R749-754			RK73FB2A273J	CHIP R	27K	J	1/10W	
R755-760			RK73FB2A220J	CHIP R	22	J	1/10W	
R761-766			RK73FB2A333J	CHIP R	33K	J	1/10W	
R767-772			RK73FB2A471J	CHIP R	470	J	1/10W	
R773-778			RS14GB3A4R7J	FL-PROOF RS	4.7	J	1W	
R779-782			RS14GB3A392J	FL-PROOF RS	3.9K	J	1W	
R783,784			RK73FB2A333J	CHIP R	33K	J	1/10W	
R785-787			RK73FB2A472J	CHIP R	4.7K	J	1/10W	
R788-790			RK73FB2A103J	CHIP R	10K	J	1/10W	
R791,792			RS14GB3A221J	FL-PROOF RS	220	J	1W	
R795-800			RK73FB2A332J	CHIP R	3.3K	J	1/10W	
R902			RK73FB2A471J	CHIP R	470	J	1/10W	
R903			RK73FB2A103J	CHIP R	10K	J	1/10W	MY
R904			RK73FB2A102J	CHIP R	1.0K	J	1/10W	MY
R905			RK73FB2A681J	CHIP R	680	J	1/10W	MY
R906			RK73FB2A332J	CHIP R	3.3K	J	1/10W	
R907			RK73FB2A333J	CHIP R	33K	J	1/10W	
R910			RK73FB2A103J	CHIP R	10K	J	1/10W	
R911			RK73FB2A122J	CHIP R	1.2K	J	1/10W	
R912,913			RK73FB2A472J	CHIP R	4.7K	J	1/10W	
R914,915			RK73FB2A101J	CHIP R	100	J	1/10W	
R916			RN14BK2E2200F	RN	220	F	1/4W	
R917			RN14BK2E4R70F	RN	4.7	F	1/4W	
R918			RK73FB2A472J	CHIP R	4.7K	J	1/10W	
R922			RK73FB2A683J	CHIP R	68K	J	1/10W	
R923			RK73FB2A104J	CHIP R	100K	J	1/10W	
R924			RK73FB2A103J	CHIP R	10K	J	1/10W	
R926			RK73FB2A102J	CHIP R	1.0K	J	1/10W	
R927			RK73FB2A103J	CHIP R	10K	J	1/10W	
R928			RK73FB2A183J	CHIP R	18K	J	1/10W	
R929			RK73FB2A472J	CHIP R	4.7K	J	1/10W	
R930			RK73FB2A473J	CHIP R	47K	J	1/10W	

L : Scandinavia K : USA P : Canada R : Mexico C : China I : Malaysia

Y : PX(Far East,Hawaii) T : England E : Europe G : Germany V : China(Shanghai)

Y : AAFES(Europe) X : Australia Q : Russia H : Korea M : Other Areas Δ indicates safety critical components .

* New Parts

Parts without **Parts No.** are not supplied.Les articles non mentionnés dans le **Parts No.** ne sont pas fournis.Teile ohne **Parts No.** werden nicht geliefert.

8

Ref. No	Add-ress	New Parts	Parts No.	Description	Quantity	Unit	Desti-nation	Re-marks
R931			RK73FB2A103J	CHIP R	10K	J	1/10W	
R934			RK73FB2A103J	CHIP R	10K	J	1/10W	
R935			RK73FB2A153J	CHIP R	15K	J	1/10W	
R936			RK73FB2A123J	CHIP R	12K	J	1/10W	
R937			RK73FB2A472J	CHIP R	4.7K	J	1/10W	
R938			RK73FB2A223J	CHIP R	22K	J	1/10W	
R941			RK73FB2A472J	CHIP R	4.7K	J	1/10W	
R942,943			RK73FB2A473J	CHIP R	4.7K	J	1/10W	
R944			RK73FB2A472J	CHIP R	4.7K	J	1/10W	
Δ R945		*	R92-1980-08	METAL R	3.3M	J	2W	K
Δ R946,947		*	R92-1979-08	METAL R	0.22	J	1W	
R948-950			RK73FB2A513J	CHIP R	51K	J	1/10W	
R951-953			RK73FB2A273J	CHIP R	27K	J	1/10W	
R955			RK73FB2A333J	CHIP R	33K	J	1/10W	
R956			RD14GB2E1R0J	FL-POOF RD	1	J	1/4W	
RLY701-703			S76-0076-05	RELAY	G680242000000			
Δ RLY901		*	S76-0104-08	RELAY	G680000130020			MY
Δ SW901		*	S62-0098-08	SLIDE SW	G060040550010			MY
Δ SW902		*	S62-0099-08	SLIDE SW	G060040540010			MY
D701-703			RLS4148	D,SWITCHING-UNK				
D705,706		*	KDS184ST1	D,SWITCHING CHI				
D708		*	KDS184ST1	D,SWITCHING CHI				
Δ D901-904		*	IN4007	D,SWITCHING				
D905		*	RLS4148	D,SWITCHING-UNK				
D906,907			1SS133	D,SWITCHING				
Δ D908-911		*	IN4007	D,SWITCHING				
Δ D912,913		*	DBF60C	D,RECTIFIER BRI				
Δ D912,913		*	D5SB20-4003	D,RECTIFIER BRI				
D916		*	1SS133	D,SWITCHING				
D917		*	KDS184ST1	D,SWITCHING CHI				MY
D918,919			1SS133	D,SWITCHING				
DZ321,322			MTZJ6.8B	D,ZENER				
DZ701-704			MTZJ8.2B	D,ZENER				
DZ901			MTZJ6.8B	D,ZENER				
DZ902			MTZJ16B	D,ZENER				
DZ903			MTZJ5.1B	D,ZENER				
DZ904			MTZJ6.2B	D,ZENER				
DZ905			MTZJ20B	D,ZENER				
DZ906			MTZJ18B	D,ZENER				
DZ907			MTZJ6.2B	D,ZENER				
DZ908			MTZJ5.1B	D,ZENER				
DZ909			MTZJ10B	D,ZENER				
IC311			LC7821	IC(FUNCTION CONTROL SWITCH)				
IC312			NJU7311AM	IC,LOGIC				
IC313			M62446FP	IC(ELECTRIC TONE VOLUME)P/6CH				
IC314			NJM4565MD	IC(OP AMP X2)				
Δ IC701,702			STK410-010	IC,LINEAR POWER				
Δ IC901			NJM7809FA	IC,LINEAR-REGUL				
Δ IC902			NJM7812FA	IC(VOLTAGE REGULATOR/ +12V)16W				
Δ IC903			TA7805S	IC,LINEAR-REGUL KIA7805AP 20W				
Δ IC904			NJM7912FA	IC(VOLTAGE REGULATOR)912FA,16W				
Q303,304			DTC343TK	SEMI,CHIP TR/NP				
Q305			DTA114EK	SEMI,CHIP TR/PN				
Q321-332			DTC343TK	SEMI,CHIP TR/NP				

L : Scandinavia K : USA P : Canada R : Mexico C : China I : Malaysia

Y : PX(Far East,Hawaii) T : England E : Europe G : Germany V : China(Shanghai)

Y : AAFES(Europe) X : Australia Q : Russia H : Korea M : Other Areas Δ indicates safety critical components .

* New Parts
 Parts without **Parts No.** are not supplied.
 Les articles non mentionnés dans le **Parts No.** ne sont pas fournis.
 Teile ohne **Parts No.** werden nicht geliefert.

9

Ref. No	Addr- ress	New Parts	Parts No.	Description	Desti- nation	Re- marks
Q333-336 Q701-706 Q707-709 Q901 Q902		*	DTA114EK KTC3875Y KTC3875Y KTC3206Y KTC3875Y	SEMI,CHIP TR/PN SEMI,CHIP TR/NP SEMI,CHIP TR/NP SEMI,TR/GE NPN SEMI,TR/GE NPN	MY	
Q903,904 Q905 Q906,907 Q908 Q909		*	KTC3875Y 2SA916Y KTC3875Y 2SA916Y KTC3206Y	SEMI,CHIP TR/NP SEMI,TR/GE PNP SEMI,CHIP TR/NP SEMI,TR/GE PNP SEMI,TR/GE NPN		KSA916Y
Q910 Q911 Q912 Q913,914 Q916,917		*	KTC3875Y 2SA916Y 2SA992F KTC3875Y KTC3875Y	SEMI,CHIP TR/NP SEMI,TR/GE PNP SEMI,TR/GE PNP SEMI,CHIP TR/NP SEMI,CHIP TR/NP		KSA992F
Q918 Q919,920			2SC3205Y KTC3875Y	SEMI,TR/GE NPN SEMI,CHIP TR/NP		KTC3205Y
INPUT/SURROUND BOARD (RXD-NV701 only)						
C250-253 C254,255 C256-265 C266,267 C268-272			CC73FSL1H470J CE04KW1V100M CC73FSL1H221J CE04KW1A101M CK73FB1H473K	CHIP C ELECTRO CHIP C ELECTRO CHIP C		47PF J 10UF 35WV 220PF J 100UF 10WV 0.047UF K
C601 C602 C603 C604 C605-607			CC73FSL1H220J CK73FB1H103K CK73FB1H104K CC73FSL1H220J CK73FB1H104K	CHIP C CHIP C CHIP C CHIP C CHIP C		22PF J 0.010UF K 0.10UF K 22PF J 0.10UF K
C608 C609 C610 C612 C614			C91-0757-05 CE04KW1V100M CK73FB1H104K CE04KW1A471M CE04KW1H100M	CERAMIC ELECTRO CHIP C ELECTRO ELECTRO		1000PF K 10UF 35WV 0.10UF K 470UF 10WV 10UF 50WV
C615 C617 C618 C619 C620			CK73FB1H102K CE04KW1H010M CK73FB1H153K CK73FB1H152K CK73FB1H102K	CHIP C ELECTRO CHIP C CHIP C CHIP C		1000PF K 1.0UF 50WV 0.015UF K 1500PF K 1000PF K
C621 C622 C623 C624 C625			CE04KW1A221M CK73FB1H102K CE04KW1A221M CC73FSL1H220J CC73FSL1H221J	ELECTRO CHIP C ELECTRO CHIP C CHIP C		220UF 10WV 1000PF K 220UF 10WV 22PF J 220PF J
C627,628 C629 C630 C631 C632L			CC73FSL1H270J C91-0753-05 CK73FB1H102K CK73FB1H103K CE04KW1H3R3M	CHIP C CERAMIC CHIP C CHIP C ELECTRO		27PF J 470PF K 1000PF K 0.010UF K 3.3UF 50WV
C632R C633L C633R C634L C634R			CE04KW1H3R3M CC73FSL1H471J CC73FSL1H471J CC73FSL1H680J CC73FSL1H680J	ELECTRO CHIP C CHIP C CHIP C CHIP C		3.3UF 50WV 470PF J 470PF J 68PF J 68PF J
C635L			CE04KW1V100M	ELECTRO		10UF 35WV

L: Scandinavia K: USA P: Canada R: Mexico C: China I: Malaysia
 Y: PX(Far East,Hawaii) T: England E: Europe G: Germany V: China(Shanghai)
 Y: AAFES(Europe) X: Australia Q: Russia H: Korea M: Other Areas Δ indicates safety critical components.

* New Parts
 Parts without **Parts No.** are not supplied.
 Les articles non mentionnés dans le **Parts No.** ne sont pas fournis.
 Teile ohne **Parts No.** werden nicht geliefert.

10

Ref. No	Addr- ress	New Parts	Parts No.	Description	Desti- nation	Re- marks
C635R C636,637 C638C C638L C638R			CE04KW1V100M CE04KW1C101M CE04KW1V100M CE04KW1V100M CE04KW1V100M	ELECTRO ELECTRO ELECTRO ELECTRO ELECTRO		10UF 35WV 100UF 16WV 10UF 35WV 10UF 35WV 10UF 35WV
C638SL C638SR C638SW C639C C639L			CE04KW1V100M CE04KW1V100M CE04KW1V100M CC73FSL1H220J CC73FSL1H220J	ELECTRO ELECTRO ELECTRO CHIP C CHIP C		10UF 35WV 10UF 35WV 10UF 35WV 22PF J 22PF J
C639R C639SL C639SR C639SW C640C			CC73FSL1H220J CC73FSL1H220J CC73FSL1H220J CC73FSL1H220J CK73FB1H102K	CHIP C CHIP C CHIP C CHIP C CHIP C		22PF J 22PF J 22PF J 22PF J 1000PF K
C640L C640R C640SL C640SR C640SW			CK73FB1H102K CK73FB1H102K CK73FB1H102K CK73FB1H102K CQ93FMG1H182J	CHIP C CHIP C CHIP C CHIP C MYLAR		1000PF K 1000PF K 1000PF K 1000PF K 1800PF J
C641C C641L C641R C641SL C641SR			CK73FB1H152K CK73FB1H152K CK73FB1H152K CK73FB1H152K CK73FB1H152K	CHIP C CHIP C CHIP C CHIP C CHIP C		1500PF K 1500PF K 1500PF K 1500PF K 1500PF K
C641SW C642C C642L C642R C642SL			CQ93FMG1H822J CE04KW1V100M CE04KW1V100M CE04KW1V100M CE04KW1V100M	MYLAR ELECTRO ELECTRO ELECTRO ELECTRO		8200PF J 10UF 35WV 10UF 35WV 10UF 35WV 10UF 35WV
C642SR C642SW C643C C643L C643R			CE04KW1V100M CE04KW1C470M CK73FB1H182K CK73FB1H182K CK73FB1H182K	ELECTRO ELECTRO CHIP C CHIP C CHIP C		10UF 35WV 47UF 16WV 1800PF K 1800PF K 1800PF K
C643SL C643SR C650,651 C652 C653,654			CK73FB1H182K CK73FB1H182K CE04KW1V100M CE04KW1H010M CC73FSL1H101J	CHIP C CHIP C ELECTRO ELECTRO CHIP C		1800PF K 1800PF K 10UF 35WV 1.0UF 50WV 100PF J
C655,656 C657			CE04KW1V100M CK73FB1H473K	ELECTRO CHIP C		10UF 35WV 0.047UF K
RCA1 RCA2 RCA3 RCA4		*	E63-1185-08 E63-1186-08 E63-1187-08 E63-1188-08	TER,RCA 1PIN TER,RCA 4PIN TER,RCA 4PIN TER,RCA 6PIN		G600010003100 G602401170020 G602401170010 G603601180000
L601 L602,604 L605 XTAL601		*	L33-0574-08 L92-0523-08 L33-0574-08 L77-2325-08	COIL,FILTER-IND CHIP FERRITE COIL COIL,FILTER-IND CRYSTAL12.288MHZ		10UH 7611010000020 10UH E80012R288020
R250-253 R254 R255 R256			RK73FB2A750J RK73FB2A102J RK73FB2A224J RK73FB2A102J	CHIP R CHIP R CHIP R CHIP R		75 J 1/10W 1.0K J 1/10W 220K J 1/10W 1.0K J 1/10W

L: Scandinavia K: USA P: Canada R: Mexico C: China I: Malaysia
 Y: PX(Far East,Hawaii) T: England E: Europe G: Germany V: China(Shanghai)
 Y: AAFES(Europe) X: Australia Q: Russia H: Korea M: Other Areas Δ indicates safety critical components.

PARTS LIST

RXD-NV301/NV301E/NV701/NV701E

* New Parts
Parts without **Parts No.** are not supplied.
Les articles non mentionnés dans le **Parts No.** ne sont pas fournis.
Teile ohne **Parts No.** werden nicht geliefert.

11

Ref. No	Add-ress	New Parts	Parts No.	Description	Desti-nation	Re-marks
R257			RK73FB2A224J	CHIP R	220K	J 1/10W
R258			RK73FB2A102J	CHIP R	1.0K	J 1/10W
R259			RK73FB2A224J	CHIP R	220K	J 1/10W
R260			RK73FB2A102J	CHIP R	1.0K	J 1/10W
R261			RK73FB2A224J	CHIP R	220K	J 1/10W
R262			RK73FB2A102J	CHIP R	1.0K	J 1/10W
R263			RK73FB2A224J	CHIP R	220K	J 1/10W
R264			RK73FB2A102J	CHIP R	1.0K	J 1/10W
R265			RK73FB2A224J	CHIP R	220K	J 1/10W
R266			RK73FB2A102J	CHIP R	1.0K	J 1/10W
R267			RK73FB2A224J	CHIP R	220K	J 1/10W
R268			RK73FB2A102J	CHIP R	1.0K	J 1/10W
R269			RK73FB2A224J	CHIP R	220K	J 1/10W
R270			RK73FB2A102J	CHIP R	1.0K	J 1/10W
R271			RK73FB2A224J	CHIP R	220K	J 1/10W
R272			RK73FB2A102J	CHIP R	1.0K	J 1/10W
R273			RK73FB2A224J	CHIP R	220K	J 1/10W
R601			RK73FB2A471J	CHIP R	470	J 1/10W
R602			RK73FB2A105J	CHIP R	1.0M	J 1/10W
R603			RK73FB2A102J	CHIP R	1.0K	J 1/10W
R604			RK73FB2A820J	CHIP R	82	J 1/10W
R605			RK73FB2A104J	CHIP R	100K	J 1/10W
R606			RK73FB2A183J	CHIP R	18K	J 1/10W
R607			RK73FB2A472J	CHIP R	4.7K	J 1/10W
R608,609			RK73FB2A104J	CHIP R	100K	J 1/10W
R610			RK73FB2A473J	CHIP R	47K	J 1/10W
R611			RS14GB3A3R3J	FL-PROOF RS	3.3	J 1/W
R615,616			RK73FB2A103J	CHIP R	10K	J 1/10W
R618			RK73FB2A473J	CHIP R	47K	J 1/10W
R619			RK73FB2A433J	CHIP R	43K	J 1/10W
R621			RK73FB2A2R2J	CHIP R	2.2	J 1/10W
R629			RK73FB2A103J	CHIP R	10K	J 1/10W
R630L			RK73FB2A471J	CHIP R	470	J 1/10W
R630R			RK73FB2A471J	CHIP R	470	J 1/10W
R631L			RK73FB2A473J	CHIP R	47K	J 1/10W
R631R			RK73FB2A473J	CHIP R	47K	J 1/10W
R632L			RK73FB2A222J	CHIP R	2.2K	J 1/10W
R632R			RK73FB2A222J	CHIP R	2.2K	J 1/10W
R633L			RK73FB2A103J	CHIP R	10K	J 1/10W
R633R			RK73FB2A103J	CHIP R	10K	J 1/10W
R636-638			RK73FB2A103J	CHIP R	10K	J 1/10W
R639			RK73FB2A471J	CHIP R	470	J 1/10W
R640			RK73FB2A105J	CHIP R	1.0M	J 1/10W
R643,644			RK73FB2A103J	CHIP R	10K	J 1/10W
R656-658			RK73FB2A103J	CHIP R	10K	J 1/10W
R660C			RK73FB2A104J	CHIP R	100K	J 1/10W
R660L			RK73FB2A104J	CHIP R	100K	J 1/10W
R660R			RK73FB2A104J	CHIP R	100K	J 1/10W
R660SL			RK73FB2A104J	CHIP R	100K	J 1/10W
R660SR			RK73FB2A104J	CHIP R	100K	J 1/10W
R660SW			RK73FB2A104J	CHIP R	100K	J 1/10W
R661C			RK73FB2A101J	CHIP R	100	J 1/10W
R661L			RK73FB2A101J	CHIP R	100	J 1/10W
R661R			RK73FB2A101J	CHIP R	100	J 1/10W
R661SL			RK73FB2A101J	CHIP R	100	J 1/10W

L : Scandinavia K : USA P : Canada R : Mexico C : China I : Malaysia
Y : PX(Far East,Hawaii) T : England E : Europe G : Germany V : China(Shanghai)
Y : AAFES(Europe) X : Australia Q : Russia H : Korea M : Other Areas Δ indicates safety critical components .

* New Parts
Parts without **Parts No.** are not supplied.
Les articles non mentionnés dans le **Parts No.** ne sont pas fournis.
Teile ohne **Parts No.** werden nicht geliefert.

12

Ref. No	Add-ress	New Parts	Parts No.	Description	Desti-nation	Re-marks
R661SR			RK73FB2A101J	CHIP R	100	J 1/10W
R661SW			RK73FB2A101J	CHIP R	100	J 1/10W
R662C			RK73FB2A332J	CHIP R	3.3K	J 1/10W
R662L			RK73FB2A332J	CHIP R	3.3K	J 1/10W
R662R			RK73FB2A332J	CHIP R	3.3K	J 1/10W
R662SL			RK73FB2A332J	CHIP R	3.3K	J 1/10W
R662SR			RK73FB2A332J	CHIP R	3.3K	J 1/10W
R662SW			RK73FB2A153J	CHIP R	15K	J 1/10W
R663C			RK73FB2A332J	CHIP R	3.3K	J 1/10W
R663L			RK73FB2A332J	CHIP R	3.3K	J 1/10W
R663R			RK73FB2A332J	CHIP R	3.3K	J 1/10W
R663SL			RK73FB2A332J	CHIP R	3.3K	J 1/10W
R663SR			RK73FB2A332J	CHIP R	3.3K	J 1/10W
R663SW			RK73FB2A153J	CHIP R	15K	J 1/10W
R664C			RK73FB2A102J	CHIP R	1.0K	J 1/10W
R664L			RK73FB2A102J	CHIP R	1.0K	J 1/10W
R664R			RK73FB2A102J	CHIP R	1.0K	J 1/10W
R664SL			RK73FB2A102J	CHIP R	1.0K	J 1/10W
R664SR			RK73FB2A102J	CHIP R	1.0K	J 1/10W
R664SW			RK73FB2A222J	CHIP R	2.2K	J 1/10W
R665C			RK73FB2A152J	CHIP R	1.5K	J 1/10W
R665L			RK73FB2A152J	CHIP R	1.5K	J 1/10W
R665R			RK73FB2A152J	CHIP R	1.5K	J 1/10W
R665SL			RK73FB2A152J	CHIP R	1.5K	J 1/10W
R665SR			RK73FB2A152J	CHIP R	1.5K	J 1/10W
R665SW			RK73FB2A123J	CHIP R	12K	J 1/10W
R666C			RK73FB2A222J	CHIP R	2.2K	J 1/10W
R666L			RK73FB2A222J	CHIP R	2.2K	J 1/10W
R666R			RK73FB2A222J	CHIP R	2.2K	J 1/10W
R666SL			RK73FB2A222J	CHIP R	2.2K	J 1/10W
R666SR			RK73FB2A222J	CHIP R	2.2K	J 1/10W
R667C			RK73FB2A103J	CHIP R	10K	J 1/10W
R667L			RK73FB2A103J	CHIP R	10K	J 1/10W
R667R			RK73FB2A103J	CHIP R	10K	J 1/10W
R667SL			RK73FB2A103J	CHIP R	10K	J 1/10W
R667SR			RK73FB2A103J	CHIP R	10K	J 1/10W
R667SW			RK73FB2A103J	CHIP R	10K	J 1/10W
R672-674			RK73FB2A103J	CHIP R	10K	J 1/10W
R676-678			RK73FB2A103J	CHIP R	10K	J 1/10W
R679,680			RK73FB2A335J	CHIP R	3.3M	J 1/10W
R682			RK73FB2A102J	CHIP R	1.0K	J 1/10W
R683,684			RK73FB2A105J	CHIP R	1.0M	J 1/10W
R685,686			RK73FB2A4R7J	CHIP R	4.7	J 1/10W
D251,252			MTZJ5.1B	D,ZENER		
D601-604		*	KDS193ST1	D,SWITCHING CHI		
D605			MTZJ8.2B	D,ZENER		
IC251			NJM2279D	IC(VIDEO IC)		
IC601		*	MC74HC04AD	IC,LOGIC		
IC602			CS4226-KQ	IC(SURROUND)		
IC603			YSS912	IC(DOLBY DIGITAL(AC3),DTS)P100		
IC604			TK11233AM	IC(REGULATOR)UL		
IC605-609			NJM4565MD	IC(OP AMP X2)		
Q601			DTC114YS	SEMI,BRT/NPN RC		
Q602			DTA114YS	SEMI,BRT/PNP RA		

L : Scandinavia K : USA P : Canada R : Mexico C : China I : Malaysia
Y : PX(Far East,Hawaii) T : England E : Europe G : Germany V : China(Shanghai)
Y : AAFES(Europe) X : Australia Q : Russia H : Korea M : Other Areas Δ indicates safety critical components .

PARTS LIST

RXD-NV301/NV301E/NV701/NV701E

* New Parts

Parts without **Parts No.** are not supplied.

Les articles non mentionnés dans le **Parts No.** ne sont pas fournis.

Teile ohne **Parts No.** werden nicht geliefert.

13

Ref. No	Add-ress	New Parts	Parts No.	Description	Desti-nation	Re-marks
Q604,605 Q606,607 Q608,609			DTA114YS DTA114TS 2SK117(Y)	SEMI,BRT/PNP SEMI,BRT/NPN RC SEMI,FET/2SN 2KS117Y		
OPT1 OPT2			W02-2731-05 W02-2732-05	MODULE MODULE E100155100020 E100155100010		
FRONT BOARD						
FL101 LED101-108 LED111		*	B30-2591-08 B30-2592-08 B30-2593-08	DISPLAY,FLT LED,ROUND LED,ROUND K530167800010 K500036000020 K500032500020		
C101 C102 C103 C104 C105			CK73FB1H102K CE04KW1C470M C91-0769-05 CE04KW1A221M C91-0769-05	CHIP C ELECTRO CERAMIC ELECTRO CERAMIC 1000PF K 47UF 16WV 0.010UF K 220UF 10WV 0.010UF K		
C106 C107 C108,109 C110 C112-115			CK73FB1H103K C91-0769-05 CK73FB1H103K CQ92FM1H223J CK73FB1H103K	CHIP C CERAMIC CHIP C MYLAR CHIP C 0.010UF K 0.010UF K 0.022UF J 0.010UF K		
C151 C152,153 C154 C155 C156			CE04KW1C470M CC73FSL1H200J CK73FB1H103K CE04KW1A221M C90-3968-08	ELECTRO CHIP C CHIP C ELECTRO ELECTRO 47UF 16WV 20PF J 0.010UF K 220UF 10WV 0.047F 5.5WV		
C157,158 C159 C160 C161 C162		*	CC73FSL1H330J CK73FB1H103K CC73FSL1H271J CE04KW1H2R2M CC73FSL1H561J	CHIP C CHIP C CHIP C ELECTRO CHIP C 33PF J 0.010UF K 270PF J 2.2UF 50WV 560PF J	TEE2 TEE2 TEE2 TEE2 TEE2	
C163 C164-172 C173			CK73FB1H103K CK73FB1H103K CE04KW1C330M	CHIP C CHIP C ELECTRO 0.010UF K 0.010UF K 33UF 16WV	TEE2	
CP101 CP105 CP106 CP107		*	E40-8739-08 E40-8740-08 E40-8741-08 E40-8742-08	FFC CN 1.25MM15P L131837001500 PIN ASSY 2MM 9P L101530150910 PIN ASSY 2MM 7PP L101530150710 PIN ASSY 2MM 11P L101530151110		
BD101 X101 X102 X103 X104		*	L92-0017-05 L78-0294-05 L78-0294-05 L77-2318-08 L77-2319-08	FERRITE CORE RESONATOR,CERAM E830100000050 RESONATOR,CERAM E830100000050 RESONATOR,CERAM E800327680050 CRYSTAL4.332000M E800433200080	TEE2	
J113 J246 J247-251 R36-39 R61-64			RK73FB2A000J RK73FB2A000J RK73FB2A000J RK73FB2A683J RK73FB2A472J	CHIP R CHIP R CHIP R CHIP R CHIP R 0 J 1/10W 0 J 1/10W 0 J 1/10W 68K J 1/10W 4.7K J 1/10W	TEE2	7
R65,66 R67-82 R84-92 R112,113 R114			RK73FB2A472J RK73FB2A472J RK73FB2A472J RK73FB2A473J RK73FB2A472J	CHIP R CHIP R CHIP R CHIP R CHIP R 4.7K J 1/10W 4.7K J 1/10W 4.7K J 1/10W 47K J 1/10W 4.7K J 1/10W		7
R124,125 R128-130			RK73FB2A221J RK73FB2A121J	CHIP R CHIP R 220 J 1/10W 120 J 1/10W		

L : Scandinavia K : USA P : Canada R : Mexico C : China I : Malaysia
 Y : PX(Far East,Hawaii) T : England E : Europe G : Germany V : China(Shanghai)
 Y : AAFES(Europe) X : Australia Q : Russia H : Korea M : Other Areas Δ indicates safety critical components.

* New Parts

Parts without **Parts No.** are not supplied.

Les articles non mentionnés dans le **Parts No.** ne sont pas fournis.

Teile ohne **Parts No.** werden nicht geliefert.

14

Ref. No	Add-ress	New Parts	Parts No.	Description	Desti-nation	Re-marks
R131-133 R134 R135 R136 R137			RK73FB2A103J RK73FB2A102J RK73FB2A122J RK73FB2A152J RK73FB2A222J	CHIP R CHIP R CHIP R CHIP R CHIP R 10K J 1/10W 1.0K J 1/10W 1.2K J 1/10W 1.5K J 1/10W 2.2K J 1/10W		
R138 R140 R141 R142 R143			RK73FB2A332J RK73FB2A102J RK73FB2A122J RK73FB2A152J RK73FB2A222J	CHIP R CHIP R CHIP R CHIP R CHIP R 3.3K J 1/10W 1.0K J 1/10W 1.2K J 1/10W 1.5K J 1/10W 2.2K J 1/10W		
R144 R145 R147 R148,149 R156,157			RK73FB2A332J RK73FB2A512J RK73FB2A121J RK73FB2A201J RK73FB2A101J	CHIP R CHIP R CHIP R CHIP R CHIP R 3.3K J 1/10W 5.1K J 1/10W 120 J 1/10W 200 J 1/10W 100 J 1/10W		7
R158,159 R164-168 R173 R174 R175			RK73FB2A101J RK73FB2A101J RK73FB2A103J RK73FB2A224J RK73FB2A153J	CHIP R CHIP R CHIP R CHIP R CHIP R 100 J 1/10W 100 J 1/10W 10K J 1/10W 220K J 1/10W 15K J 1/10W		7 EE2
R175 R175 R179 R181 R183			RK73FB2A272J RK73FB2A682J RK73FB2A105J RK73FB2A560J RK73FB2A101J	CHIP R CHIP R CHIP R CHIP R CHIP R 2.7K J 1/10W 6.8K J 1/10W 1.0M J 1/10W 56 J 1/10W 100 J 1/10W	K MXY	
R184 R187-190 R193 R194,195 R198			RK73FB2A101J RK73FB2A473J RK73FB2A473J RK73FB2A473J RK73FB2A153J	CHIP R CHIP R CHIP R CHIP R CHIP R 100 J 1/10W 47K J 1/10W 47K J 1/10W 47K J 1/10W 15K J 1/10W	TEE2	3
R199,200 R201 R202 R207,208 R212			RK73FB2A473J RK73FB2A472J RK73FB2A473J RK73FB2A101J RK73FB2A101J	CHIP R CHIP R CHIP R CHIP R CHIP R 47K J 1/10W 4.7K J 1/10W 47K J 1/10W 100 J 1/10W 100 J 1/10W	TEE2	
R218 R242-245 VR101		*	RK73FB2A473J RK73FB2A101J R32-0098-08	CHIP R CHIP R SW,ENCODER 47K J 1/10W 100 J 1/10W G121000040010		
SW101-113			S70-0059-08	SW,TACT G180000210030		
D101,102 D103 D104 IC101 IC102			1SS133 KDS226 1SS133 CXP82832-196Q CXP82852-311Q	D,SWITCHING D,SWITCHING CHI D,SWITCHING IC,CPU MICRO PR IC,CPU MICRO PR		3
IC102 IC103 Q101-106 Q110 Q111		*	CXP82860-312Q BU1924F DTC144EK 2SC3205Y DTC144EK	IC,CPU MICRO PR IC,LINEAR RF SEMI,CHIP TR/NP SEMI,TR/GE NPN SEMI,CHIP TR/NP	TEE2	7
Q112,113 Q114 Q115 Q120-123 ZD111			DTC343TK DTC114TK DTA114EK KTC3875Y MTZJ10B	SEMI,CHIP TR/NP SEMI,CHIP TR/NP SEMI,CHIP TR/PN SEMI,CHIP TR/NP D,ZENER		

L : Scandinavia K : USA P : Canada R : Mexico C : China I : Malaysia
 Y : PX(Far East,Hawaii) T : England E : Europe G : Germany V : China(Shanghai)
 Y : AAFES(Europe) X : Australia Q : Russia H : Korea M : Other Areas Δ indicates safety critical components.

PARTS LIST

RXD-NV301/NV301E/NV701/NV701E

* New Parts
Parts without **Parts No.** are not supplied.
Les articles non mentionnés dans le **Parts No.** ne sont pas fournis.
Teile ohne **Parts No.** werden nicht geliefert.

15

Ref. No	Add-ress	New Parts	Parts No.	Description	Desti-nation	Re-marks
REM101		*	W02-2794-08	MODULE_REMOCONE940633800000		
DECK BOARD						
C401,402 C403,404 C405,406 C407,408 C409,410			CC45FSL1H821J CE04KW1C220M CQ92FM1H183J CC45FSL1H331J CE04KW1H010M	CERAMIC ELECTRO MYLAR CERAMIC ELECTRO	820PF 22UF 0.018UF 330PF 1.0UF	J 16WV J J 50WV
C411-416 C417 C418 C419 C420			CE04KW1H4R7M CE04KW1H2R2M CE04KW1H4R7M CE04KW1C470M CE04KW1HR47M	ELECTRO ELECTRO ELECTRO ELECTRO ELECTRO	4.7UF 2.2UF 4.7UF 47UF 0.47UF	50WV 50WV 50WV 16WV 50WV
C421 C422 C423 C425,426 C427,428			CE04KW1H3R3M CE04KW1C101M CE04KW1C470M CK45FB1H104Z CE04KW1H4R7M	ELECTRO ELECTRO ELECTRO CERAMIC ELECTRO	3.3UF 100UF 47UF 0.10UF 4.7UF	50WV 16WV 16WV Z 50WV
C429,430 C431,432 C433-436 C438 C439			CE04KW1H2R2M CE04KW1HR22M CE04KW1H2R2M CE04KW1C101M CE04KW1E221M	ELECTRO ELECTRO ELECTRO ELECTRO ELECTRO	2.2UF 0.22UF 2.2UF 100UF 220UF	50WV 50WV 50WV 16WV 25WV
C440 C441 C442 C443 C445			CQ92FM1H332J CQ92FM1H473J CQ92FM1H222J CQ92FM1H332J CQ92FM1H682J	MYLAR MYLAR MYLAR MYLAR MYLAR	3300PF 0.047UF 2200PF 3300PF 6800PF	J J J J J
C446 C447,448 C449 C450 C451			CQ92FM1H333J CC45FSL1H221J CQ92FM1H223J CE04KW1C101M CE04KW1E221M	MYLAR CERAMIC MYLAR ELECTRO ELECTRO	0.033UF 220PF 0.022UF 100UF 220UF	J J J 16WV 25WV
C452,453 C454 C455 C457 C465			CK73FB1H272K CC73FSL1H101J CK73FB1H103K CK73FB1H103K CK73FB1H103K	CHIP C CHIP C CHIP C CHIP C CHIP C	2700PF 100PF 0.010UF 0.010UF 0.010UF	K J K K K
C467 J444			CK73FB1H103K CF92FV1H682J	CHIP C MF-C	0.010UF 6800PF	K J
CN401 CN402 CN404 CN405		*	E40-8735-08 E40-8736-08 E40-8737-08 E40-8738-08	CN WIRE (6P)90 CN WIRE (11P)100 CN WIRE (7P)200 CN WIRE (9P)150	L000900060040 L000101110030 L000201070010 L000151090030	
BD401,402 T401 T402,403 T404,405		*	L92-0523-08 L32-1035-08 L39-1391-08 L35-0072-08	BEAD,COIL CHIP BIAS OSC COIL TRAP COIL MPX COIL	7611010000020 E080516900000 D302126522400 E401503000000	
J448-454 R401,402 R403,404 R405-406 R407			RK73FB2A000J RK73FB2A100J RK73FB2A473J RK73FB2A121J RK73FB2A123J	CHIP R CHIP R CHIP R CHIP R CHIP R	0 10 47K 120 12K	J J J 1/10W J 1/10W
R408			RK73FB2A102J	CHIP R	1.0K	J 1/10W

L : Scandinavia K : USA P : Canada R : Mexico C : China I : Malaysia
Y : PX(Far East,Hawaii) T : England E : Europe G : Germany V : China(Shanghai)
Y : AAFES(Europe) X : Australia Q : Russia H : Korea M : Other Areas Δ indicates safety critical components .

* New Parts
Parts without **Parts No.** are not supplied.
Les articles non mentionnés dans le **Parts No.** ne sont pas fournis.
Teile ohne **Parts No.** werden nicht geliefert.

16

Ref. No	Add-ress	New Parts	Parts No.	Description	Desti-nation	Re-marks
R409 R410 R411 R412 R413			RK73FB2A333J RK73FB2A474J RK73FB2A242J RK73FB2A472J RK73FB2A562J	CHIP R CHIP R CHIP R CHIP R CHIP R	33K 470K 2.4K 4.7K 5.6K	J J J J J 1/10W 1/10W 1/10W 1/10W 1/10W
R414-417 R418 R420 R421 R423			RK73FB2A682J RK73FB2A124J RK73FB2A242J RK73FB2A473J RK73FB2A102J	CHIP R CHIP R CHIP R CHIP R CHIP R	6.8K 120K 2.4K 47K 1.0K	J J J J J 1/10W 1/10W 1/10W 1/10W 1/10W
R425 R426 R427 R428-431 R432			RK73FB2A473J RK73FB2A102J RK73FB2A124J RK73FB2A562J RK73FB2A103J	CHIP R CHIP R CHIP R CHIP R CHIP R	47K 1.0K 120K 5.6K 10K	J J J J J 1/10W 1/10W 1/10W 1/10W 1/10W
R433 R434 R435 R437-441 R442,443			RK73FB2A333J RK73FB2A473J RK73FB2A273J RK73FB2A103J RK73FB2A153J	CHIP R CHIP R CHIP R CHIP R CHIP R	33K 47K 27K 10K 15K	J J J J J 1/10W 1/10W 1/10W 1/10W 1/10W
R445 R446 R447 R448 R450			RK73FB2A102J RK73FB2A183J RK73FB2A362J RK73FB2A223J RK73FB2A473J	CHIP R CHIP R CHIP R CHIP R CHIP R	1.0K 18K 3.6K 22K 47K	J J J J J 1/10W 1/10W 1/10W 1/10W 1/10W
R451 R452 R453 R454 R455			RK73FB2A332J RK73FB2A473J RK73FB2A101J RK73FB2A562J RK73FB2A822J	CHIP R CHIP R CHIP R CHIP R CHIP R	3.3K 47K 100 5.6K 8.2K	J J J J J 1/10W 1/10W 1/10W 1/10W 1/10W
R456 R457 R459 R460 R462			RK73FB2A433J RK73FB2A223J RK73FB2A103J RK73FB2A473J RK73FB2A102J	CHIP R CHIP R CHIP R CHIP R CHIP R	43K 22K 10K 47K 1.0K	J J J J J 1/10W 1/10W 1/10W 1/10W 1/10W
R464 R465,466 R467 R468 R469			RK73FB2A102J RK73FB2A103J RK73FB2A332J RK73FB2A102J RK73FB2A103J	CHIP R CHIP R CHIP R CHIP R CHIP R	1.0K 10K 3.3K 1.0K 10K	J J J J J 1/10W 1/10W 1/10W 1/10W 1/10W
R471,472 R473 R475 R476 VR401,402			RK73FB2A102J RK73FB2A103J RK73FB2A563J RK73FB2A102J R39-0025-08	CHIP R CHIP R CHIP R CHIP R VR,SEMI CERMET	1.0K 10K 56K 1.0K C544103015130	J J J J J 1/10W 1/10W 1/10W 1/10W
VR403,404 VR405,406 VR407		*	R12-3686-05 R32-0098-08 R32-0099-08	VR,SEMI CERMET SEMI VR R(100KB) SEMI VR R(2.2KB)	C544223015140 C544104015140 C544222015150	
D401 IC401 IC402 Q401,402 Q403			1SS133 CXA1897Q BA3126N DTC343TK KTA1273Y	D,SWITCHING IC,LINEAR EQ IC(HEAD SW) SEMI,CHIP TR/NP SEMI,TR/GE PNP		
Q404			DTC114ES	SEMI,BRT/NPN RC		

L : Scandinavia K : USA P : Canada R : Mexico C : China I : Malaysia
Y : PX(Far East,Hawaii) T : England E : Europe G : Germany V : China(Shanghai)
Y : AAFES(Europe) X : Australia Q : Russia H : Korea M : Other Areas Δ indicates safety critical components .

* New Parts
 Parts without **Parts No.** are not supplied.
 Les articles non mentionnes dans le **Parts No.** ne sont pas fournis.
 Teile ohne **Parts No.** werden nicht geliefert.

17

Ref. No	Add-ress	New Parts	Parts No.	Description	Desti-nation	Re-marks
Q405			DTC144EK	SEMI,CHIP TR/NP		
Q406			DTA114ES	SEMI,BRT/PNP RA		
Q407			DTC143TK	SEMI,CHIP TR/NP		
Q408			KTA1273Y	SEMI,TR/GE PNP		
Q409			DTC114ES	SEMI,BRT/NPN RC		
Q410			KTA1273Y	SEMI,TR/GE PNP		
Q411			DTC114ES	SEMI,BRT/NPN RC		
Q413			DTC114EK	SEMI,CHIP TR/NP		
Q414			KTA1273Y	SEMI,TR/GE PNP		
Q415,416			DTC114YS	SEMI,BRT/NPN RC		
Q417,418			2SC1740SR	SEMI,TR/GE NPN		
Q419			2SD1302	SEMI,TR/GE NPN	KTD1302B	
Q420			KTA1504Y	SEMI,CHIP TR/PN		
Q421			2SC3205Y	SEMI,TR/GE NPN	KTC3205Y	
ZD401			MTZJ5.1B	D,ZENER		
CD BOARD						
C501			CE04KW1A101M	ELECTRO	100UF	10WV
C502			CE04KW1H010M	ELECTRO	1.0UF	50WV
C503			CK45FB1H102K	CERAMIC	1000PF	K
C504			CE04KW1A101M	ELECTRO	100UF	10WV
C505			CC45FSL1H150J	CERAMIC	15PF	J
C506			CC45FSL1H221J	CERAMIC	220PF	J
C507			CC45FSL1H471J	CERAMIC	470PF	J
C508			CE04KW1A101M	ELECTRO	100UF	10WV
C509			CE04KW1HR47M	ELECTRO	0.47UF	50WV
C510			CQ92FM1H103J	MYLAR	0.010UF	J
C511			CC45FSL1H101J	CERAMIC	100PF	J
C512			CQ92FM1H332J	MYLAR	3300PF	J
C513			CQ92FM1H473J	MYLAR	0.047UF	J
C514			CQ92FM1H152J	MYLAR	1500PF	J
C515			CE04KW1A101M	ELECTRO	100UF	10WV
C516			CK45FB1H104Z	CERAMIC	0.10UF	Z
C517			CC45FSL1H101J	CERAMIC	100PF	J
C519			CQ92FM1H103J	MYLAR	0.010UF	J
C520			CE04KW1A471M	ELECTRO	470UF	10WV
C521-524			CK45FB1H104Z	CERAMIC	0.10UF	Z
C525			CE04KW1A471M	ELECTRO	470UF	10WV
C530			CK45FB1H102K	CERAMIC	1000PF	K
C531			CC45FSL1H101J	CERAMIC	100PF	J
C532			CE04KW1A101M	ELECTRO	100UF	10WV
C533			CK73FB1H104Z	CHIP C	0.10UF	Z
C534			CC45FSL1H101J	CERAMIC	100PF	J
C535			CC45FSL1H221J	CERAMIC	220PF	J
C536,537			CC73FSL1H270J	CHIP C	27PF	J
C550			CE04KW1A470M	ELECTRO	47UF	10WV
C561,562			CC73FSL1H181J	CHIP C	180PF	J
C563,564			CK73FB1H102K	CHIP C	1000PF	K
C565			CC73FSL1H101J	CHIP C	100PF	J
C566			CC73FSL1H101J	CHIP C	100PF	J
C569,570			CE04KW1H2R2M	ELECTRO	2.2UF	50WV
C571,572			CC73FSL1H330J	CHIP C	33PF	J
C573,574			CE04KW1H2R2M	ELECTRO	2.2UF	50WV
C588			CK73FB1H104Z	CHIP C	0.10UF	Z
C589			CE04KW1A101M	ELECTRO	100UF	10WV
C590			CK73FB1H104Z	CHIP C	0.10UF	Z

L : Scandinavia K : USA P : Canada R : Mexico C : China I : Malaysia
 Y : PX(Far East,Hawaii) T : England E : Europe G : Germany V : China(Shanghai)
 Y : AAFES(Europe) X : Australia Q : Russia H : Korea M : Other Areas Δ indicates safety critical components.

* New Parts
 Parts without **Parts No.** are not supplied.
 Les articles non mentionnes dans le **Parts No.** ne sont pas fournis.
 Teile ohne **Parts No.** werden nicht geliefert.

18

Ref. No	Add-ress	New Parts	Parts No.	Description	Desti-nation	Re-marks
C591			CE04KW1A471M	ELECTRO	470UF	10WV
C592			CK45FB1H223Z	CERAMIC	0.022UF	Z
C593			CE04KW1H010M	ELECTRO	1.0UF	50WV
C594			CE04KW1A221M	ELECTRO	220UF	10WV
C595			CK73FB1H102K	CHIP C	1000PF	K
C596			CE04KW1H100M	ELECTRO	10UF	50WV
CP501		*	E40-8743-08	CN FFC 1.25MM31P	L131120310020	
CP502			E40-8173-08	CN FFC 1.0MM16P	L130528071610	
L501			L33-0574-08	COIL,FILTER-IND	D330100700520	
X501		*	L77-2320-08	CRYSTAL16.9344MHZ	E80016R934420	
NS			RK73FB2A000J	CHIP R	0	J 1/10W
R505			RK73FB2A103J	CHIP R	10K	J 1/10W
R522			RK73FB2A332J	CHIP R	3.3K	J 1/10W
R540,541		*	R92-1978-08	FUSE METAL	2.2	J 1/2W
R547			RK73FB2A222J	CHIP R	2.2K	J 1/10W
R548			RK73FB2A562J	CHIP R	5.6K	J 1/10W
R561-566			RK73FB2A103J	CHIP R	10K	J 1/10W
R567,568			RK73FB2A102J	CHIP R	1.0K	J 1/10W
R569			RK73FB2A332J	CHIP R	3.3K	J 1/10W
R571-576			RK73FB2A104J	CHIP R	100K	J 1/10W
R588,589			RK73FB2A103J	CHIP R	10K	J 1/10W
D501-504			1SS133	D,SWITCHING		
D505,506			KDS226	D,SWITCHING CHI		
IC501			CXD3017Q	IC,OPTICAL-DSP		
IC502			CXA1821M	IC(CD RF AMPLIFIER)		
IC503			BA5979S	IC(4CH BTL)RIVER		
IC504,505		*	KA3082	IC,LINEAR-DRIVE		
IC506			TC74HCT7007AF	IC(HEX BUFFER)		
IC507			NJM4565MD	IC(OP AMP X2)		
Q501			2SA1270(Y)	SEMI,TR/GE PNP		
Q502			KTA1273Y	SEMI,TR/GE PNP		
Q509,510			KTC2874B	SEMI,TR/GE NPN		
Q511			2SC3205Y	SEMI,TR/GE NPN		
Q512			DTA114EK	SEMI,CHIP TR/PN		
Q513			DTC114YS	SEMI,BRT/NPN RC		
Q514			DTC114EK	SEMI,CHIP TR/NP		
ZD501			MTZJ3.9B	D,ZENER		
ZD502			MTZJ5.1B	D,ZENER		
CD MECHANISM						
1	2C	*	A10-3538-08	BODY MECHA	3410041411010	
2	2A	*	J99-0824-08	TRAY LOADING	4600040251010	
3	1A	*	J99-0825-08	ROULETTE TRAY	2720040071010	
4	2C	*	A15-0108-08	PU BASE DRIVE	3400041391010	
5	1B	*	D13-2526-08	GEAR CENTER A	2470040291010	
6	1B	*	D13-2527-08	GEAR CENTER B	2470040211010	
7	1B	*	D13-2528-08	GEAR TRAY	2470040683010	
8	1B	*	D13-2529-08	GEAR PULLEY	2470040341010	
9	1C	*	D10-3984-08	SLIDER FUNCTION	2640040031010	
10	1B	*	D13-2532-08	ARM GEAR	2540041133010	
12	1A	*	G02-1723-08	PLATE PRESSURE	4470043816010	
13	1B	*	D16-0758-08	BELT LOADING	2470040585010	
14	1A	*	D13-2530-08	GEAR W-WHEEL	2530041563010	

L : Scandinavia K : USA P : Canada R : Mexico C : China I : Malaysia
 Y : PX(Far East,Hawaii) T : England E : Europe G : Germany V : China(Shanghai)
 Y : AAFES(Europe) X : Australia Q : Russia H : Korea M : Other Areas Δ indicates safety critical components.

PARTS LIST

RXD-NV301/NV301E/NV701/NV701E

* New Parts
 Parts without **Parts No.** are not supplied.
 Les articles non mentionnés dans le **Parts No.** ne sont pas fournis.
 Teile ohne **Parts No.** werden nicht geliefert.

19

Ref. No	Add-ress	New Parts	Parts No.	Description	Desti-nation	Re-marks
16	1C	*	J11-0867-08	PLATE CLAMPER 4470004060000		
17	1C	*	T99-0645-08	MAGNET CORE 7800GZ3400L10		
18	2C		J11-0829-08	CLAMPER 4330020041010		
21	2B	*	E35-2779-08	FFC P1.25 L230 L301700370010		
22	2C		G11-2367-08	INSULATOR RED 1240020135020		
23	2B		G11-2368-08	INSULATOR GREEN 1240020135010		
24	2B	*	W02-2795-08	PCB SENSER 7020059840000		
25	2B	*	E40-8744-08	CN 6P HOUSING 4428606965000		
26	2B	*	W02-2793-08	PHOTO.SENSOR(CD) K611230000000		
27	2B	*	S64-0054-08	SW,LEVER(CD) G140040220010		
DM	2C		D40-1515-05	TRAVERSE UNIT 8030000900020		
LM	2B	*	T42-0996-08	LOADING MOTOR ASSY		
RM	2A	*	T42-0995-08	ROTARY MOTOR ASSY		

ABBREVIATION OF MODEL AND MASS PRODUCTION'S DESTINATIONS

MODEL	ABB.	Australia	Canada	China	England	Europe	Germany	Korea	Malaysia
RXD-NV301	3	X	-	-	T	E	-	-	-
RXD-NV301E	3	-	-	-	-	E2	-	-	-
RXD-701	7	X	-	-	T	E	-	-	-
RXD-701E	7	-	-	-	-	E2	-	-	-
MODEL	ABB.	Mexico	PX/AAFES	Russia	Scandinavia	Shanghai	USA	Other area	
RXD-NV301	3	-	-	-	-	-	K	M	-
RXD-NV301E	3	-	-	-	-	-	-	-	-
RXD-701	7	-	Y	-	-	-	K	M	-
RXD-701E	7	-	-	-	-	-	-	-	-

L : Scandinavia K : USA P : Canada R : Mexico C : China I : Malaysia
 Y : PX(Far East,Hawaii) T : England E : Europe G : Germany V : China(Shanghai)
 Y : AAFES(Europe) X : Australia Q : Russia H : Korea M : Other Areas Δ indicates safety critical components .

SPECIFICATIONS

Main unit (NV-701)

[Amplifier section]

Continuous rated power output during STEREO operation (FTC)
(Front channels only) (For U.S.A., Canada, and U.S. military)

50 watts per channel minimum RMS, all channels driven,
at 6 Ω from 40 Hz to 20,000 Hz with no more than 0.9 %
total harmonic distortion.

(U.K. and Europe)

1 kHz, 0.7 % T.H.D., 6 Ω (DIN) 35 W + 35 W

(Other countries)

1 kHz, 1 % T.H.D., 6 Ω (RMS) 38 W + 38 W

Effective output power during STEREO operation

(U.S.A. and Canada)

FRONT (1 kHz, 10 % T.H.D., 6 Ω)

.....(RMS) 50 W + 50 W

SUB WOOFER (65 Hz, 10 % T.H.D., 6 Ω)

.....(RMS) 50 W

(U.K. and Europe)

FRONT (1 kHz, 10 % T.H.D., 6 Ω)

.....(RMS) 50 W + 50 W

SUB WOOFER (65 Hz, 10 % T.H.D., 6 Ω)

.....(RMS) 50 W

(U.S. military)

FRONT (1 kHz, 10 % T.H.D., 6 Ω)

.....(RMS) 50 W + 50 W

SUB WOOFER (65 Hz, 10 % T.H.D., 6 Ω)

.....(RMS) 50 W

(Other countries) (Front channels only)

FRONT (1 kHz, 10 % T.H.D., 6 Ω)

.....(RMS) 70 W + 70 W

Effective output power during SURROUND operation

(One channel driven)

FRONT (1 kHz, 10 % T.H.D., 6 Ω)

.....(RMS) 50 W + 50 W

CENTER (1 kHz, 10 % T.H.D., 6 Ω)(RMS) 50 W

SURROUND (1 kHz, 10 % T.H.D., 6 Ω)

.....(RMS) 50 W + 50 W

SUB WOOFER (65 Hz, 10 % T.H.D., 6 Ω)

.....(RMS) 50 W

Signal to noise ratio

LINE (VIDEO) 90 dB (IHF' 66)

Input sensitivity / impedance

LINE (VIDEO) 400 mV / 47 k Ω

Output level / impedance

REC OUT (VIDEO1) 400 mV / 47 k Ω

[Video]

Input level / impedance

VIDEO (composite) 1 Vp-p / 75 Ω

Output level / impedance

VIDEO (composite) 1 Vp-p / 75 Ω

[Digital]

Sampling frequency 32 kHz, 44.1 kHz, 48 kHz

Input level / impedance

Coaxial (VIDEO 1) 0.5 Vp-p / 75 Ω

Optical (VIDEO 2) -15 dBm ~ -21 dBm (660 nm \pm 30nm)

Output level / impedance

Optical -15 dBm ~ -21 dBm (660 nm \pm 30nm)

[Cassette deck section]

Track system 4-track, 2-channel stereo

Recording system AC bias

(Frequency: 105 kHz)

Heads

Playback / recording head 1

Erasing head 1

Fast winding time Approx. 110 seconds

(C-60 tape)

[CD player section]

Laser wave length 770 to 795 nm

Wow & Flutter Less than measurable Limit

[Tuner section]

FM tuner section

Reception frequency range 87.5 MHz ~ 108 MHz

MW (AM) Tuner section

Reception frequency range

(U.S.A. and Canada) 530 kHz ~ 1700 kHz

(U.K. and Europe) 531 kHz ~ 1602 kHz

(Other countries)

9 kHz step 531 kHz ~ 1602 kHz

10 kHz step 530 kHz ~ 1610 kHz

LW Tuner section (For U.K.)

Reception frequency range 153 kHz ~ 279 kHz

[General]

Power consumption

(U.S.A. and Canada) 140 W

(U.K. and Europe) 140 W

(Australia) 140 W

(For U.S. military and other regions) 140 W

Dimension W: 285 mm (11-1/4 in.)

H: 210 mm (8-1/4 in.)

D: 355 mm (14 in.)

Weight (net) 10.7 kg (23 lbs. 9 oz.)

RXD-NV301/NV301E/NV701/NV701E

SPECIFICATIONS

Main unit (NV-301)

[Amplifier section]

Continuous rated power output during STEREO operation (FTC)
(U.S.A. and Canada)

70 watts per channel minimum RMS, all channels driven,
at 6 Ω from 40 Hz to 20,000 Hz with no more than 0.9 %
total harmonic distortion.

(U.K. and Europe)

1 kHz, 0.7 % T.H.D., 6 Ω (DIN) 53 W + 53 W

(Other countries)

1 kHz, 1 % T.H.D., 6 Ω (RMS) 55 W + 55 W

Effective output power during STEREO operation

(U.S.A. and Canada)

1 kHz, 10 % T.H.D., 6 Ω (RMS) 85 W + 85 W

(U.K. and Europe)

1 kHz, 10 % T.H.D., 6 Ω (RMS) 70 W + 70 W

(Other countries)

1 kHz, 10 % T.H.D., 6 Ω (RMS) 70 W + 70 W

Signal to noise ratio

Line (MD/DVD)90 dB (IHF' 66)

Input sensitivity / impedance

Line (MD/DVD) 400 mV / 47 k Ω

Output level / impedance

Super Woofer Preout.....2 V / 600 Ω

[Cassette deck section]

Track system4-track, 2-channel stereo

Recording systemAC bias
(Frequency: 105 kHz)

Heads

Playback / recording head1

Erasing head1

Fast winding time Approx. 110 seconds
(C-60 tape)

[CD player section]

Laser wave length770 to 795 nm

Laser power classclass1

Wow & Flutter..... Less than measurable Limit

Digital output (Optical)-15 dBm ~ -21 dBm
(Wave length 660 nm)

[Tuner section]

FM tuner section

Reception frequency range..... 87.5 MHz ~ 108 MHz

MW (AM) Tuner section

Reception frequency range

(U.S.A. and Canada).....530 kHz ~ 1700 kHz

(U.K. and Europe)531 kHz ~ 1602 kHz

(Other countries)

9 kHz step531 kHz ~ 1602 kHz

10 kHz step530 kHz ~ 1610 kHz

LW Tuner section (For U.K.)

Reception frequency range 153 kHz ~ 279 kHz

[General]

Power consumption

(U.S.A. and Canada)110 W

(U.K. and Europe)110 W

(Australia)110 W

(For U.S. military and other regions)110 W

DimensionsW : 285 mm (11-1/4 in.)

H : 210 mm (8-1/4 in.)

D : 355 mm (14 in.)

Weight (net)10.2 kg (22 lbs. 8 oz.)

Note:

1. KENWOOD follows a policy of continuous advancements in development. For this reason specifications may be changed without notice.
2. Sufficient performance may not be possible at very low temperatures (0 °C or less).

Note:

Component and circuit are subject to modification to insure best operation under differing local conditions. This manual is based on Europe (E) standard, and provides information on regional circuit modification through use of alternate schematic diagrams, and information on regional component variations through use of parts list.

KENWOOD CORPORATION

14-6, Dogenzaka 1-chome, Shibuya-ku, Tokyo, 150-8501 Japan

KENWOOD SERVICE CORPORATION

P.O. BOX 22745, 2201 East Dominguez St., Long Beach, CA 90801-5745, U.S.A.

KENWOOD ELECTRONICS CANADA INC.

6070 Kestrel Road, Mississauga, Ontario, Canada L5T 1S8

KENWOOD ELECTRONICS LATIN AMERICA S.A.

P.O. BOX 55-2791, Piso 6 plaza Chase, Cl. 47 y Aquilino de la Guardia Panama, Republic de Panama

KENWOOD ELECTRONICS BRASIL LTDA.

Av. Moema, 170-17, Andar-Cobertura "B", Ed. Maximum Service Center, 04077-020 Moema, São Paulo-SP-Brasil

KENWOOD ELECTRONICS U.K. LIMITED

KENWOOD House, Dwight Road, Watford, Herts., WD1 8EB., United Kingdom

KENWOOD ELECTRONICS BELGIUM N.V.

Meachelsesteenweg 418, B-1930 Zaventem, Belgium

KENWOOD ELECTRONICS DEUTSCHLAND GMBH

Rembrücker Str. 15, 63150 Heusenstamm, Germany

KENWOOD ELECTRONICS FRANCE S.A.

13 Boulevard Ney, 75018 Paris, France

KENWOOD ELECTRONICS ITALIA S.p.A.

Via G. Sirtori, 7/9 20129, Milano, Italy

KENWOOD IBÉRICA S.A.

Bolivia, 239-08020 Barcelona, Spain

KENWOOD ELECTRONICS AUSTRALIA PTY. LTD.

(A.C.N. 001 499 074)
16 Giffnock Avenue, North Ryde, N.S.W. 2113, Australia

KENWOOD ELECTRONICS (HONG KONG) LTD.

Unit 3712-3724, Level 37, Tower 1, Metroplaza, 223 Hing Fong Road, Kwai Fong N.T., Hong Kong

KENWOOD ELECTRONICS GULF FZE

P.O.Box 61318, Jebel Ali, Dubai, U.A.E.

KENWOOD ELECTRONICS SINGAPORE PTE LTD.

No. 1 Genting Lane #02-02, KENWOOD Building, Singapore, 349544

KENWOOD ELECTRONICS (MALAYSIA) SDN BHD.

#4.01 Level 4, Wisma Academy Lot 4A, Jalan 19/1 46300 Petaling Jaya Selangor Darul Ehsan Malaysia

KENWOOD ELECTRONICS (THAILAND) CO., LTD.

2019 New Pechburi Road, Bangkapi, Huaykwang, Bangkok, 10320 Thailand