

RXD-V323/LS-N323

SERVICE MANUAL

(XD-V323)

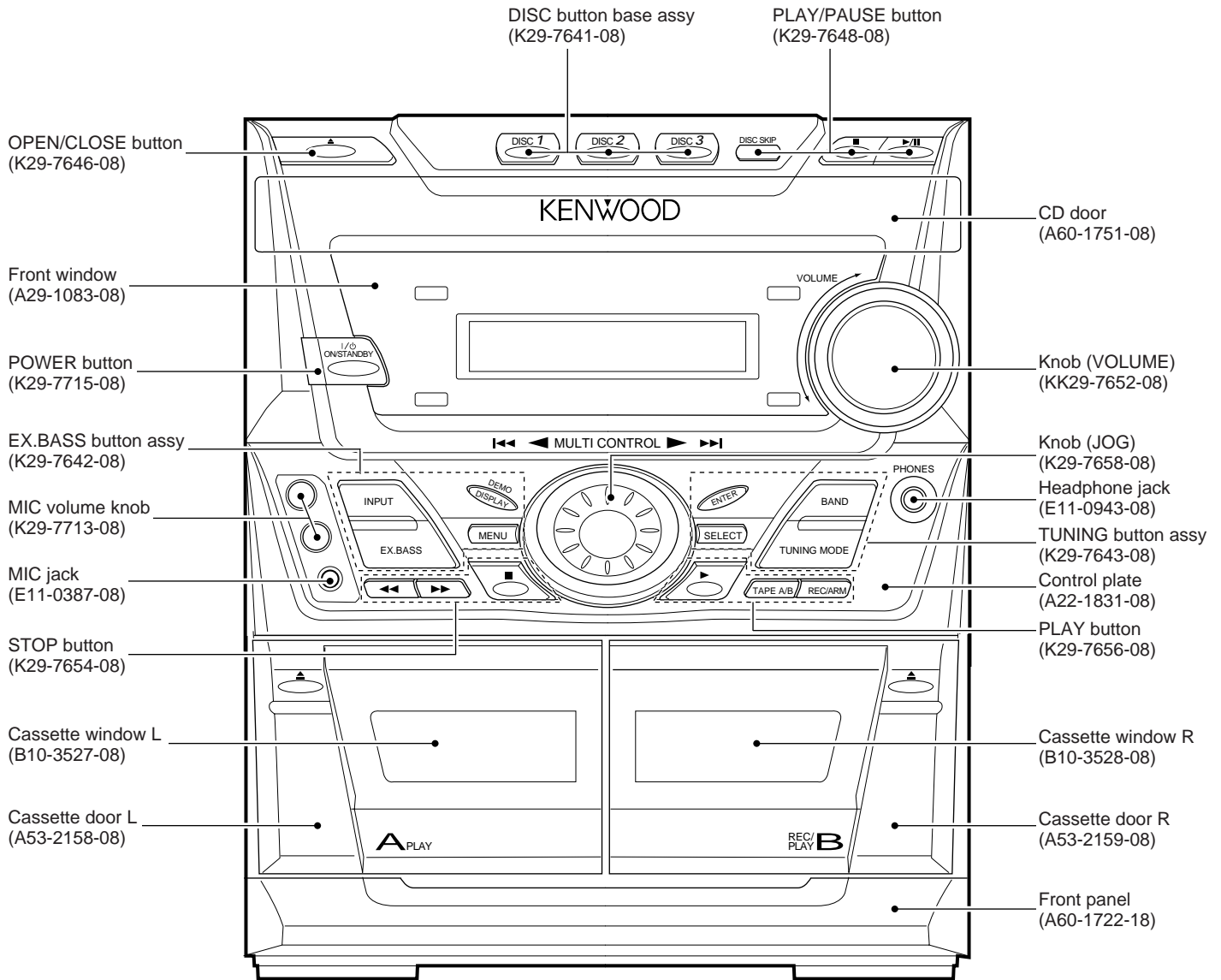

In compliance with Federal Regulations, following are reproductions of labels on, or inside the product relating to laser product safety.

Refer to RXD-251 service manual (B51-5454-00), if require to know the mechanism operation description in detail.

KENWOOD-Crop. certifies this equipment conforms to DHHS Regulations No. 21 DFR 1040. 10, Chapter 1, Subchapter J.

DANGER : Laser radiation when open and interlock defeated.
AVOID DIRECT EXPOSURE TO BEAM



RXD-V323

CONTENTS / ACCESSORIES / CAUTIONS

Contents

CONTENTS / ACCESSORIES / CAUTIONS.....	2	PC BOARD	11
EXTERNAL VIEW	3	SCHEMATIC DIAGRAM	17
BLOCK DIAGRAM	4	EXPLODED VIEW	31
CIRCUIT DESCRIPTION	5	PARTS LIST.....	33
ADJUSTMENT	8	SPECIFICATIONS	Back cover

Accessories

FM indoor antenna (1)
(T90-0847-08)

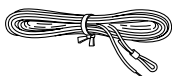

Batteries (R6/AA) (2)

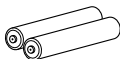

AM loop antenna (1)
(T90-0815-08)

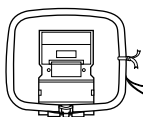

AC plug adaptor (1)
(E03-0115-05)

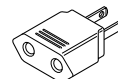

Use to adapt the plug on the power cord to the shape of the wall outlet.
(Accessory only for regions where use is necessary.)

Remote control unit (1)
(A70-1321-08) : RC-V323

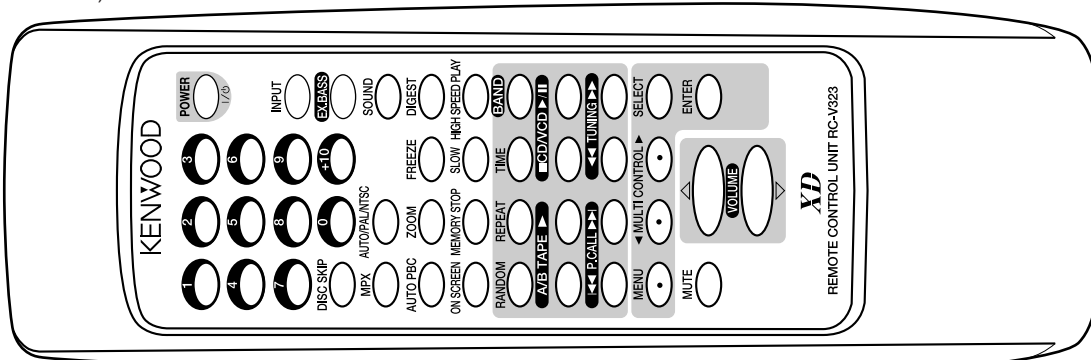

System configuration

SYSTEM	MAIN UNIT	SPEAKER
XD-V323	RXD-V323	❖LS-N323

❖ Reference number for LS-N323, refer to parts list on page 33.

Cautions

Operation to reset

The microcomputer may fall into malfunction (impossibility to operate, erroneous display, etc.) when the power cord is unplugged while power is ON or due to an external factor. In this case, execute the following procedure to reset the microcomputer and return it to normal condition.

Press the "POWER" key while holding the Stop (■) key of the CD section pressed, to switch off the power, and then switch the power on again after a few seconds.

- Please note that resetting the microcomputer clears the contents stored in and returns and to condition when it left the factory.

EXTERNAL VIEW

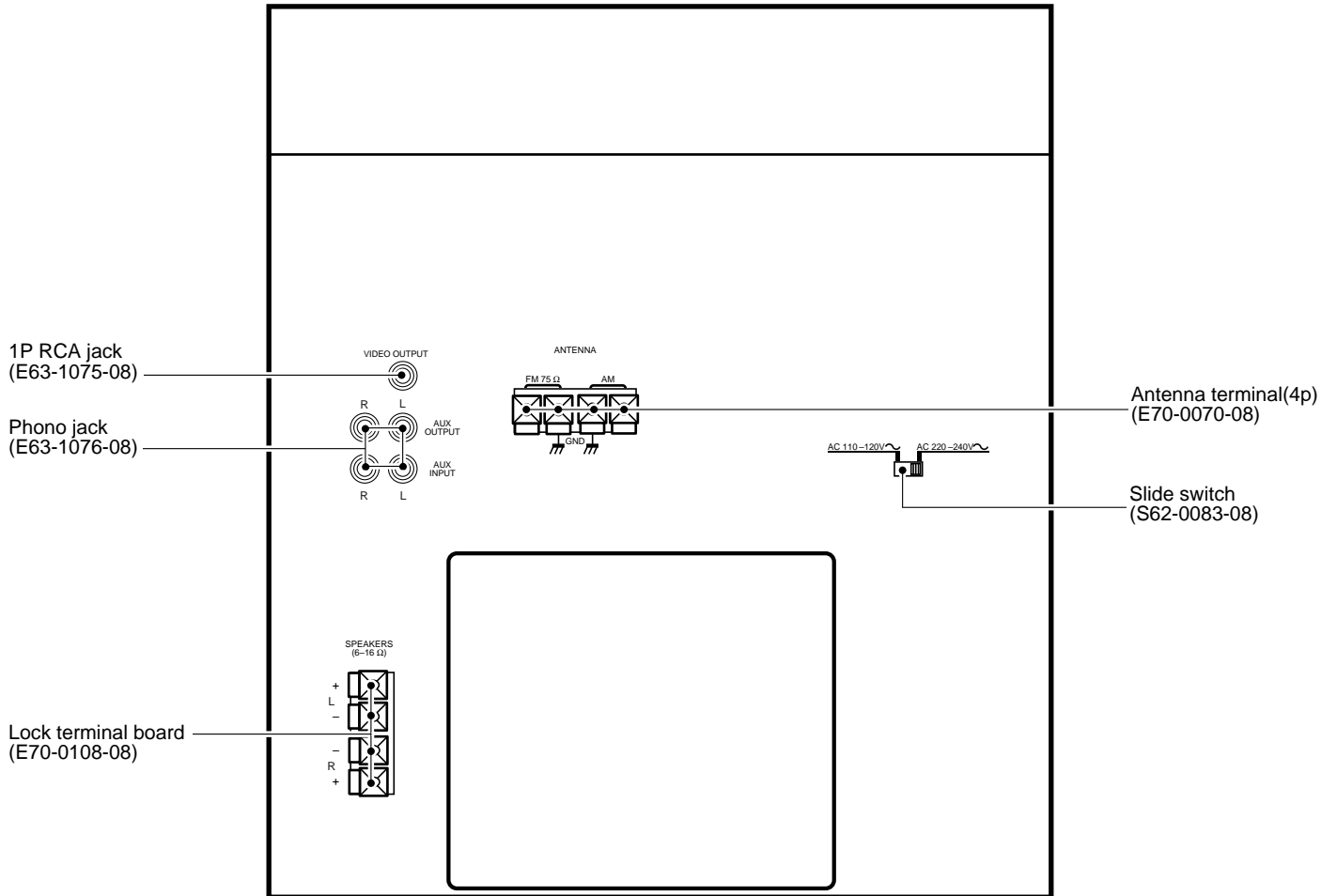

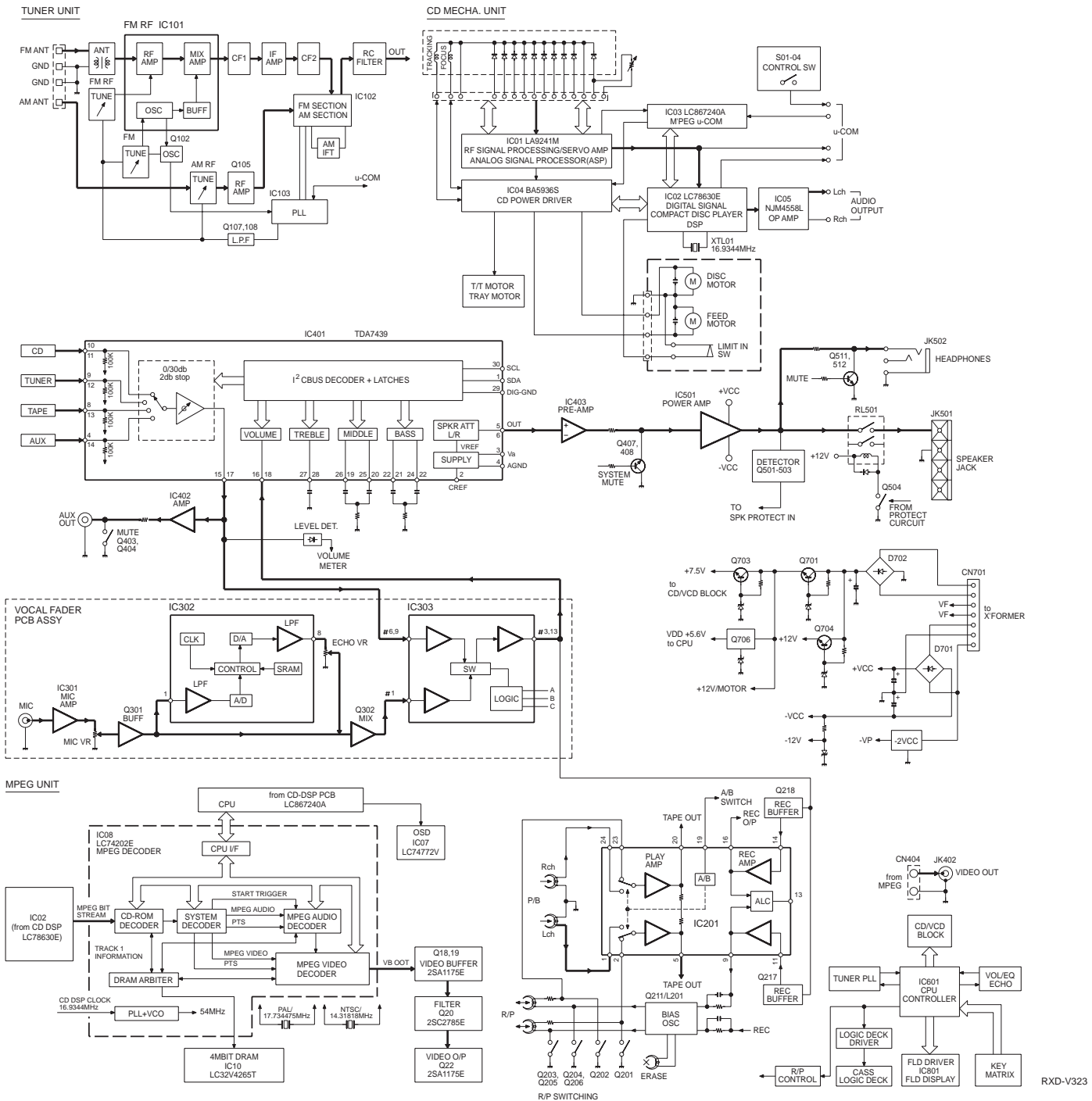

RXD-V323

BLOCK DIAGRAM

CIRCUIT DESCRIPTION

1. Reception Bands

Band	Tuning Range	Step	RF	IF
FM	87.50~108.00MHz	50kHz	25kHz	+10.7MHz
AM	531~1602kHz	9kHz	9kHz	+450kHz

2. TUNER preset frequency

M.ch	Frequency	M.ch	Frequency
1	FM 87.5MHz	16	FM 87.5MHz
2	FM 90.0MHz	17	FM 87.5MHz
3	FM 98.0MHz	18	FM 87.5MHz
4	FM 106.0MHz	19	FM 87.5MHz
5	FM 108.0MHz	20	FM 87.5MHz
6	AM 531kHz	21	FM 87.5MHz
7	AM 603kHz	22	FM 87.5MHz
8	AM 999kHz	23	FM 87.5MHz
9	AM 1404kHz	24	FM 87.5MHz
10	AM 1602kHz	25	FM 87.5MHz
11	FM 87.5MHz	26	FM 87.5MHz
12	FM 87.5MHz	27	FM 87.5MHz
13	FM 87.5MHz	28	FM 87.5MHz
14	FM 87.5MHz	29	FM 87.5MHz
15	FM 87.5MHz	30	FM 87.5MHz

3. Microprocessor : (IC601,LC867248A)

3-1. Pin description

Pin. No.	Name	I/O	Description	Active	
				H	L
1	CE	O	CE output to LC72131D(TUNER,IC103).		
2	RESET-OUT	I	LC867240A(CD,IC03) reset out.		O
3	DO	I	Data input from LC72131D(TUNER,IC103).		
4	DI	O	Data output to LC72131D(TUNER,IC03).		
5	CLK	O	Clock output to LC72131D and M66004SPA(FRONT,IC801).		
6	DATA-OUT	O	Sub CPU(CD PCB,IC03) interface data output.		
7	DATA-IN	I	Sub CPU(CD PCB,IC03) interface data input.		
8	CLK-OUT	O	Sub CPU(CD PCB,IC03) interface clock output.		
9	N/C	-	No used.		
10	STB-OUT	O	Strobe output.		
11	BUSY-IN	I	Busy input.		
12	RESET	I	Reset signal input.		O
13	POWER-DOWN	I	Power down input.		O
14	GND	-	Ground.		
15	VSS	-	Ground.		
16	X1	-	Xtal 6.0MHz .		
17	X2	-	Xtal 6.0MHz .		
18	VDD1	-	Power supply(+5.0V).		
19~21	K1~K3	I	Key input(K1~K3).		
22	K4	-	Connected to VCC.		
23	L/M	I	Level meter.		
24	EX.BASS	I	Extra bass ON/OFF signal input.		
25	DECK-MODE	I	Deck mode switch input.		
26	BAND-SW	I	Band switch input.		
27	GND	-	Ground.		
28	SP PR IN	I	Speaker protection input.	On	Off
29	REMOTE IN	I	Remocon signal input.		O
30	VR+	I	Volume encoder(VR801) input.		
31	VR-	I	Volume encoder(VR801) input.		
32	PIC-UP	I	Input port of up switch for pick up.		
33	PIC-DOWN	I	Input port of down switch for pick up.		
34	DISC-COUNT	I	Disc counter switch input.		
35	TURNTABLE SW	I	Turntable switch input.		
36	TRAY-OPEN	I	Tray open switch input.		
37	TRAY-CLOSE	I	Tray close switch input.		

RXD-V323

CIRCUIT DESCRIPTION

Pin. No.	Name	I/O	Description	Active	
				H	L
38	TURNTABLE MOTOR +	O	Turntable motor(+) control.		
39	TURNTABLE MOTOR -	O	Turntable motor(-) control.		
40	TRAY MOTOR +	O	Tray motor(+) control.		
41	TRAY MOTOR -	O	Tray motor(-) control.		
42	MOTOR SPEED	O	Motor speed control.		
43~45	-	-	No used.		
46	AUX	-	No used.		
47	TAPE	O	System muting control.		O
48	TUNER	-	No used.		
49	CD	-	No used.		
50,51	-	-	No used.		
52	LED STANDBY	O	Standby LED control.		O
53	TIMER	O	Timer LED control.		O
54	TAPE M/M SW A	I	Input port of mode switch for A deck mechanism.	Stop	Play
55	TAPE M/M SW B	I	Input port of mode switch for B deck mechanism.	Stop	Play
56	VDD	-	Power supply(+5.0V).		
57	VSS	-	Ground.		
58	TAPE M/H SW A	I	Half switch input of A deck mechanism.		
59	TAPE M/H SW B	I	Half switch input of B deck mechanism.		
60	REC.FWD SW	I	REC forward switch input.		
61	REC.RVS SW	I	REC reverse switch input.		
62	REEL PULS A	I	Reel pulse input of A deck.		
63	REEL PULS B	I	Reel pulse input of B deck.		
64	TAPE M.VCC	-	Power supply for deck mechanism.	Play	Stop
65	REC	O	Deck recording control.	Rec	Other
66	SOL.B	O	Control port of solenoid for deck B.	On	Off
67	DUBBING	O	Dubbing control.	Dubb	Nor
68	SOL.A	O	Control port of solenoid for deck A.	On	Off
69	REC.MUTE	O	REC mute control.	Other	Rec
70	BIAS	O	Deck bias control.	Rec	Other
71	A or B	O	Deck(A or B) control.	A	B
72	REC.BEAT CANCEL	O	REC beat cancel.	On	Off
73	TAPE MUTE	O	Muting control of deck line output.	On	Off
74~78	-	-	No used.		
79	SP SW OT	O	Speaker relay control.	On	Off
80	REM CODE	I	Ground.		
81,82	-	-	Ground.		
83	JOG ECD A	I	Input port of jog encoder(A).		O
84	JOG ECD B	I	Input port of jog encoder(B).		O
85	-	-	Ground.		
86	FM STEREO IN	I	FM stereo signal input.	Mono	Stereo
87	SDA	I/O	TDA7439(MAIN PCB,IC104) SDA.		
88	SCL	I/O	TDA7439(MAIN PCB,IC104) SCL.		
89	VSS2	-	Ground.		
90	VDD2	-	Power supply(+5.0V).		
91	POWER-SW	-	No used.		
92	SYS-MUTE	O	System muting control.	Off	On
93	TU-MUTE	O	Tuner muting control.	On	Off
94	LINE OUT MUTE	O	Muting control of line out.	On	Off
95	EX.BASS OUT	-	No used.		
96	V/CANCEL OUT	O	Voice cancel out.	Off	On
97	CS	O	M66004(FL driver) CS.		O
98	RESET	O	M66004(FL driver) reset.		O
99,100	-	-	No used.		

CIRCUIT DESCRIPTION

4. MPEG Microprocessor : LC867240(CD PCB,IC03)

4-1. Pin description

Pin.No.	Name	I/O	Description	Active	
				H	L
1	N/P SEL OUT	-	No used.		
2	RESET OUT	O	LC74202E(IC08),LC74772V(IC07) reset out.		O
3	DI	I	LC74772V(IC07) SIN.		
4	DO	O	No used.		
5	CL	I	LC74772V(IC07) clock.		
6	DATA OUT	O	Main CPU(IC601) interface data out.		
7	DATA IN	I	Main CPU(IC601) interface data in.		
8	SCK	I	Main CPU(IC601) interface clock.		
9	STB IN	I	Main CPU(IC601) interface STB in.		
10	BUSY OUT	O	Main CPU(IC601) interface STB out.		
11	MIRQ	I	LC74202E(IC08) IRQ.		
12	RESET	I	Reset input.		O
13,14	VSS	-	VSS		
15	VSS	-	VSS		
16,17	CF1/CF2	-	Xtal 6.0MHz.		
18	VDD	-	Power supply(+5.0V).		
19~29	VSS	-	VSS		
30	VIDEO LED	O	LED(VIDEO CD) control.		O
31	PBC	-	Playback control.		O
32~37	-	-	No used.		
38	VDD CONTROL	O	No used.		
39~55	N/C	-	No used.		
56	VDD	-	Power supply(+5.0V).		
57	VSS	-	VSS		
58~61	-	-	No used.		
62	CE	O	LC74202E(IC08) CE.		
63	CL	O	LC74202E(IC08) CL.		
64	DO	I/O	LC74202E(IC08) DO.		
65	-	-	No used.		
66	DI	I/O	LC74202E(IC08) DI.		
67~73	-	-	No used.		
74	SL +	O	Sled motor control(+).	O	
75	SL -	O	Sled motor control(-).	O	
76	SPEED B	O	Speed control terminal to IC01(LA9241).		
77	SPEED A	O	Speed control terminal to IC01(LA9241).		
78	AUDIO MUTE	O	Audio muting control.	On	Off
79	MUTE	O	BA5936S(IC04) muting control.	CD	Other
80	PIC LIMIT SW	I	Input port of pick up limit switch.		O
81~86	-	-	VSS		
87	CL	O	Command clock output to LC78630E(IC02) and LA9241(IC01).		
88	DAT	O	Command output to LC78630E(IC02) and LA9241(IC01).		
89	VSS	-	VSS		
90	VDD	-	Power supply(+5.0V).		
91	SQ OUT	I	Sub code Q input from LC78630E(IC02).		
92	RWC	O	LC78630E(IC02) RWC,LA9241(IC01) CE.		
93	RES	O	Chip reset output to LC78630E(IC02).		
94	DRF	I	DRF from LA9241(IC01).		
95,96	N/C	-	No used.		
97	CE	-	No used.		
98	VOC	-	No used.		
99	CS	O	CS to LC74772V(IC07).		
100	RESET OUT	-	No used.		

5. Key matrix

PORT	SW1	SW2	SW3	SW4	SW5	SW6	SW7	SW8
Pin 19 (K1)	Power	Input	EX Bass	Display /Demo	Menu	Select	Enter	
Pin 20 (K2)	Band	Tuning Mode	Tape Rec	A/B	Play	Stop	FF	REW
Pin 21 (K3)	CD Play Pause	Stop	Disc Skip	Disc 3	Disc2	Disc 1	Open Close	

RXD-V323

ADJUSTMENT

FM SECTION

NO.	ITEM	INPUT SETTING	OUTPUT SETTING	TUNER SETTING	ALIGNMENT POINTS	ALIGN FOR	FIG.
1	AUTO STOP LEVEL	(A) 98.0 MHz MONO 1kHz, ± 75 kHz dev 30dBu (ANT input)		AUTO 98.0MHz	SFR101	Adjust SFR101 and stop at the point where FLD801(∇) goes ON.	

MW SECTION

NO.	ITEM	INPUT SETTING	OUTPUT SETTING	TUNER SETTING	ALIGNMENT POINTS	ALIGN FOR	FIG.
1.	IF	(D) 531 kHz 1 kHz, 30% MOD 60 dBu (ANT INPUT)	(B)	531 kHz	T102	Maximum output (Minimum distortion)	
2.	LOW END TRACKING	(D) 531 kHz 1 kHz, 30% MOD 30 dBu (ANT INPUT)	(B)	531 kHz	T103	Maximum output	
3.	HIGH END TRACKING	(D) 1602 kHz 1 kHz, 30% MOD 30 dBu (ANT INPUT)	(B)	1602 kHz	TC101	Maximum output	
4.	VT	-	Connect the DC voltage meter to TP1.	531 kHz 1602 kHz	T104 -	VT=1.2V \pm 0.05V Check the VT=7.3V \pm 1.0V	

INSTRUMENTS CONNECTION

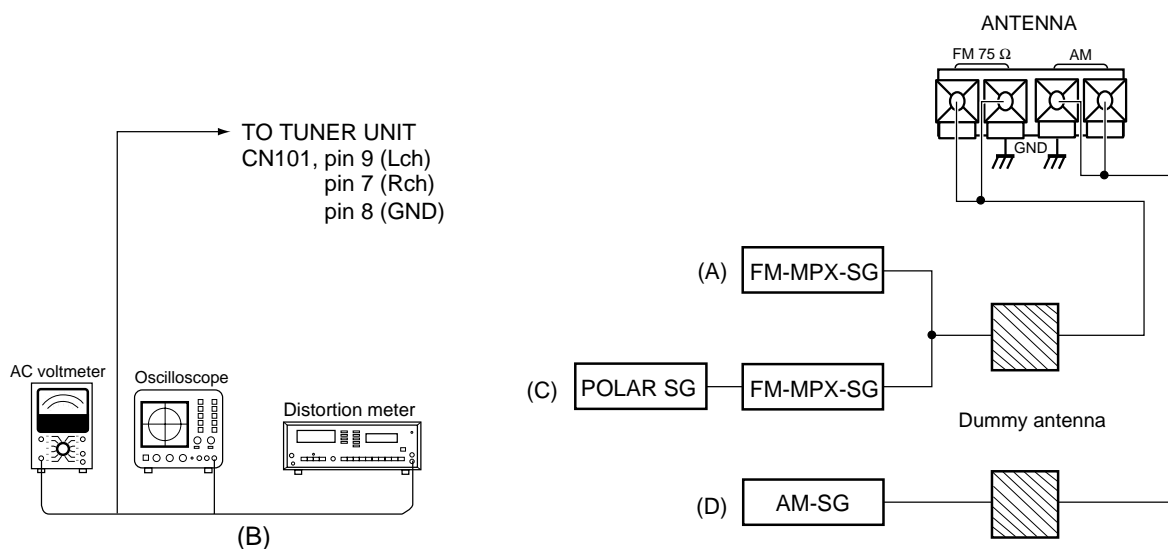

ADJUSTMENT

CASSETTE DECK SECTION

NO.	ITEM	INPUT SETTINGS	OUTPUT SETTINGS	CASSETTE TAPE DECK SETTINGS	ALIGNMENT POINT	ALIGN FOR	FIG.
Unless otherwise specified : each ; switch should be set as follows : BEAT SW : OFF I. Cassette mechanism section (REC/PB head adjustment)							0dBs = 0.775V
[1]	Demagnetization and cleaning	-	-	Power OFF, demagnetization, cleaning play	REC/PB head, erase head, capstan, pinch roller	Demagnetize the REC/PB head by head eraser. Clean the REC/PB head, erase head capstan and pinch roller with a cotton swab immersed in alcohol.	
[2]	REC/PB head azimuth	MTT-114, TCC-153 SCC-1727 10 kHz, -10dB	(A)	PLAY	Azimuth adjustment screw	In a setting wher the output is maximized, adjust the azimuth adjustment screw so that the Lissajous figure appearing on the oscilloscope screen comes near to a line slanted45° Note : The head should be installed in such a manner that it approaches the tape face.	
II. PC board adjustment							
< 1 >	Tape speed	MTT-111 TCC-100 SCC-1727 3 kHz, -4 dB	(A)	PLAY	SFR201	Adjust so that Frequency is 3 kHz at the center of the tape.	

INSTRUMENTS CONNECTION

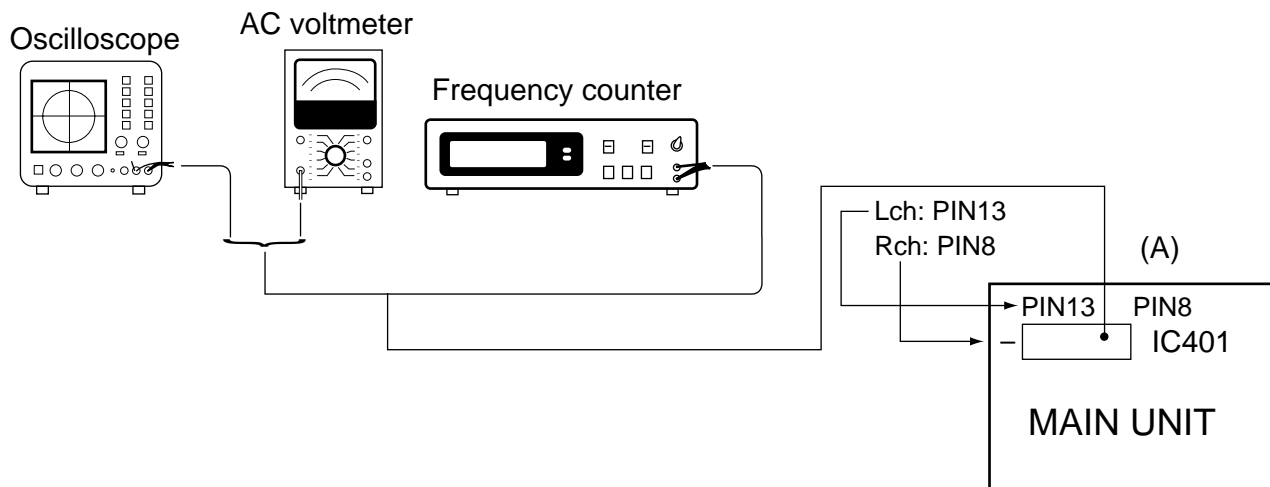

RXD-V323

ADJUSTMENT

CD SECTION

No.	ITEM	INPUT SETTINGS	OUTPUT SETTINGS	PLAYER SETTINGS	ALIGNMENT POINTS	ALIGN FOR	FIG.
1	LASER POWER	—	Apply the sensor section of optical power meter on the pickup lens.	Press the PLAY/PAUSE key.	—	On the power from 0.08 to 0.15 mW, when the diffraction grating is correctly aligned with the RF level of 0.6 Vp-p or more.	(a)

Note:

Type 4 disc : SONY YEDS-18 Test Disc or equivalent.(KTD-0*)

(a) Laser power

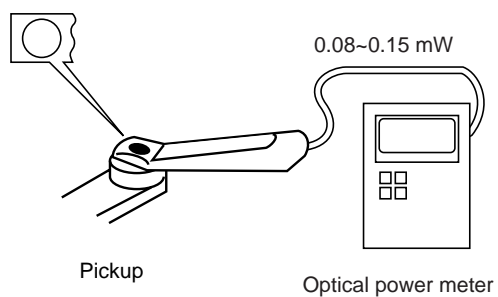

PC BOARD (Component side view)

TUNER PCB

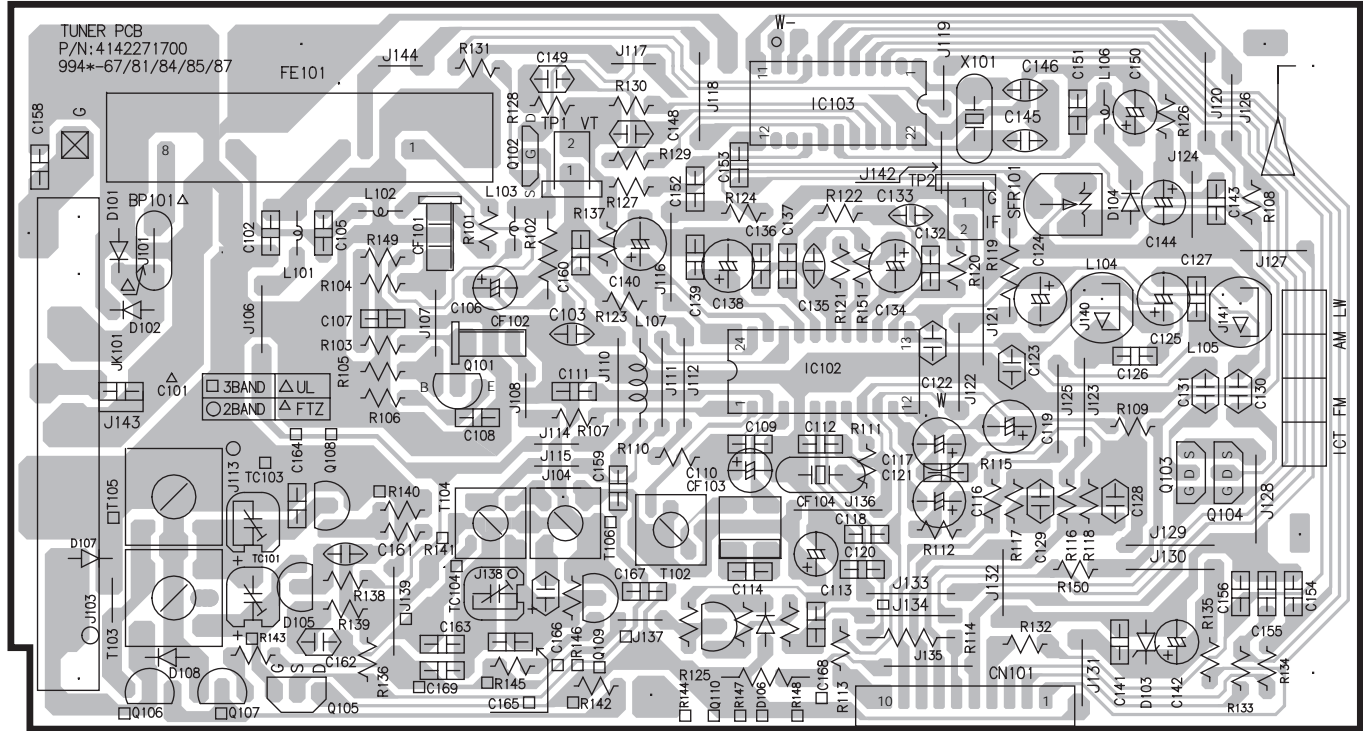

ECHO PCB

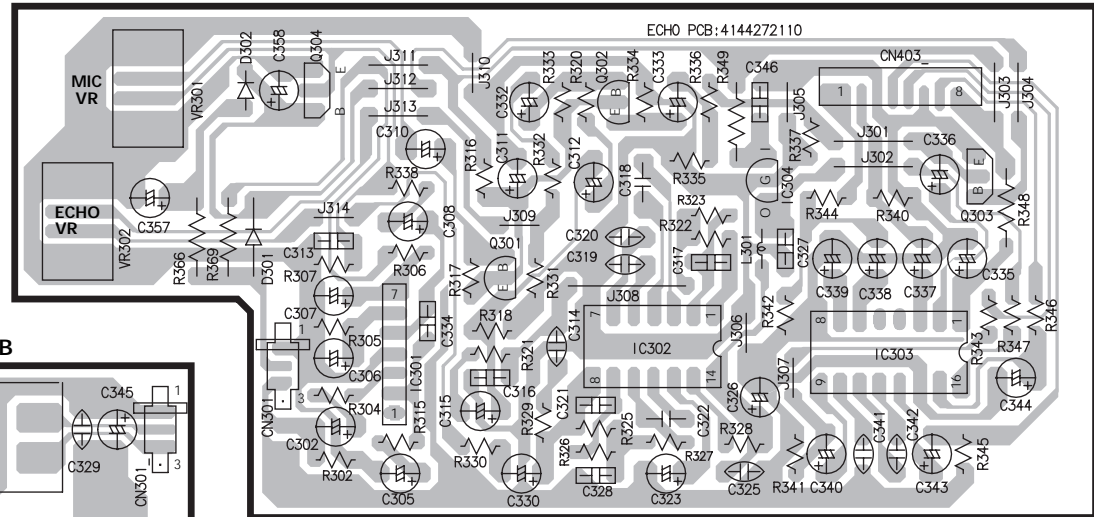

MIC JACK PCB

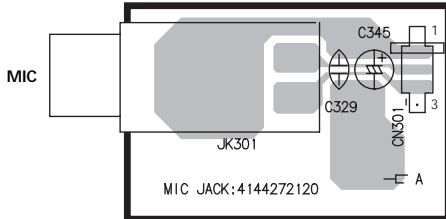

PC BOARD(Component side view)

MAIN PCB

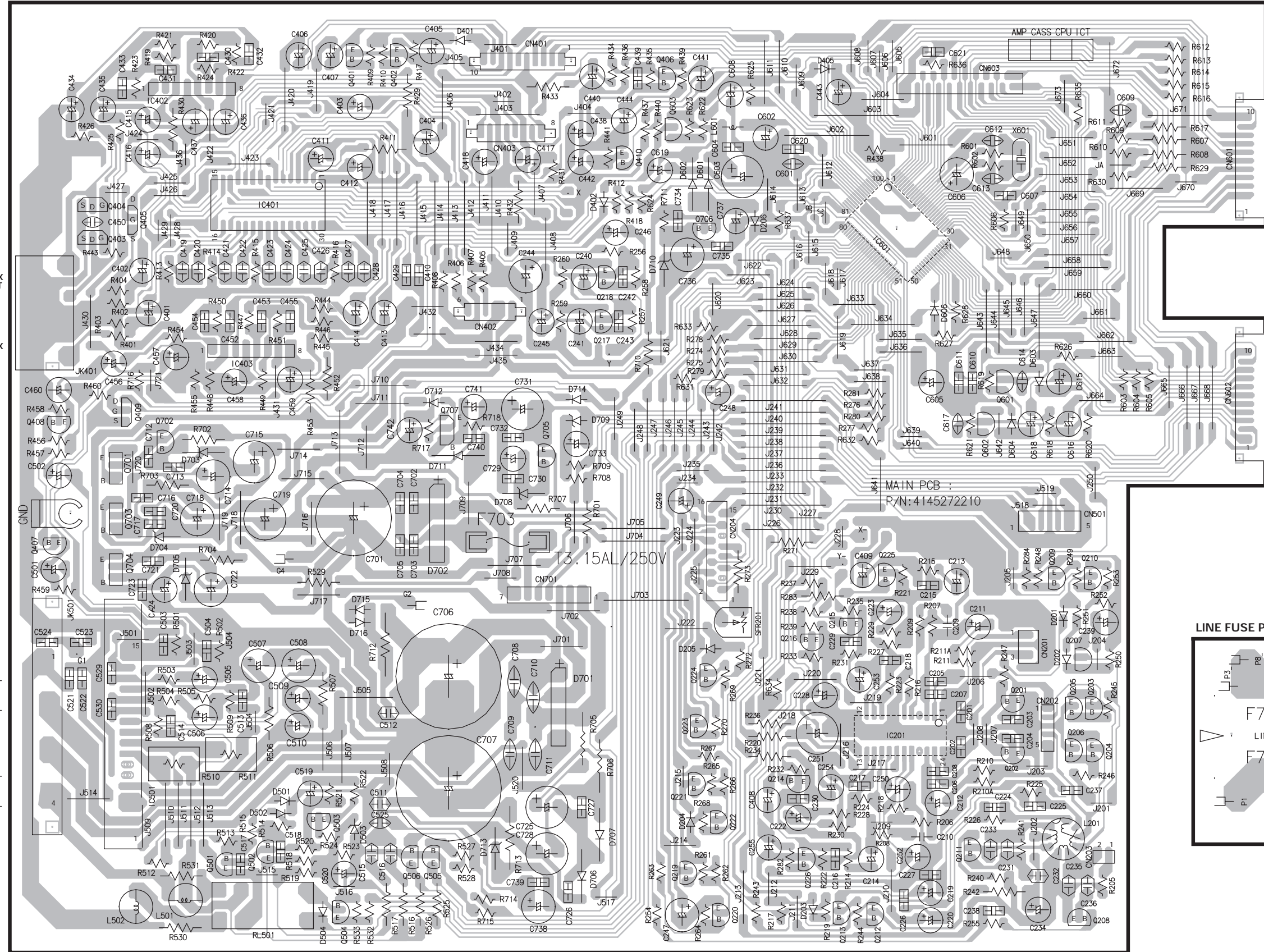

H/P PCB

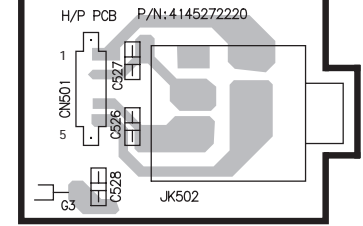

PHONES

VIDEO PCB

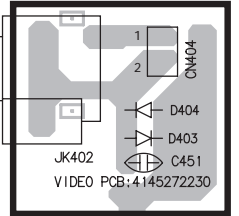

AC SELE. PCB

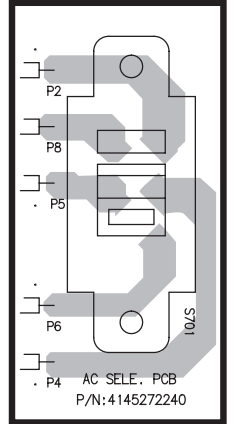

LINE FUSE PCB

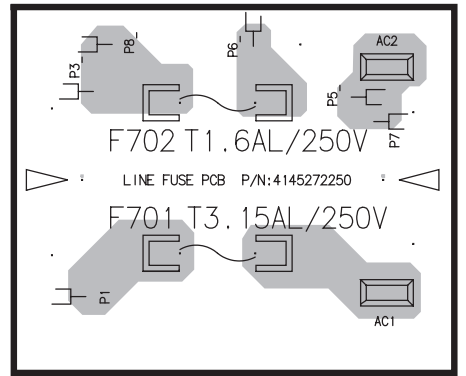

SPEAKERS

L

R

7

Refer to the schematic diagram for the value of resistors and capacitors.

PC BOARD(Component side view)

CD DECODER PCB

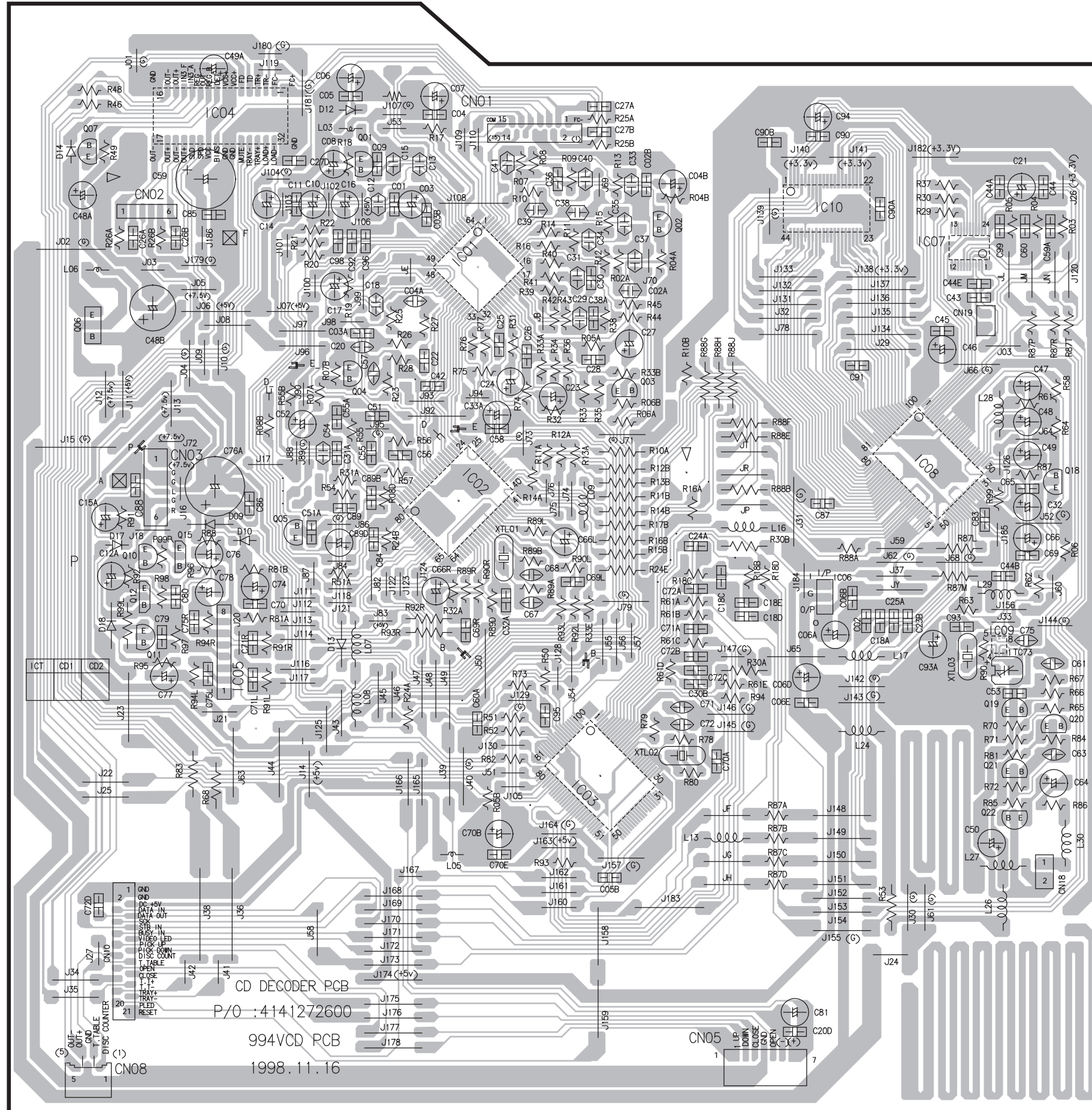

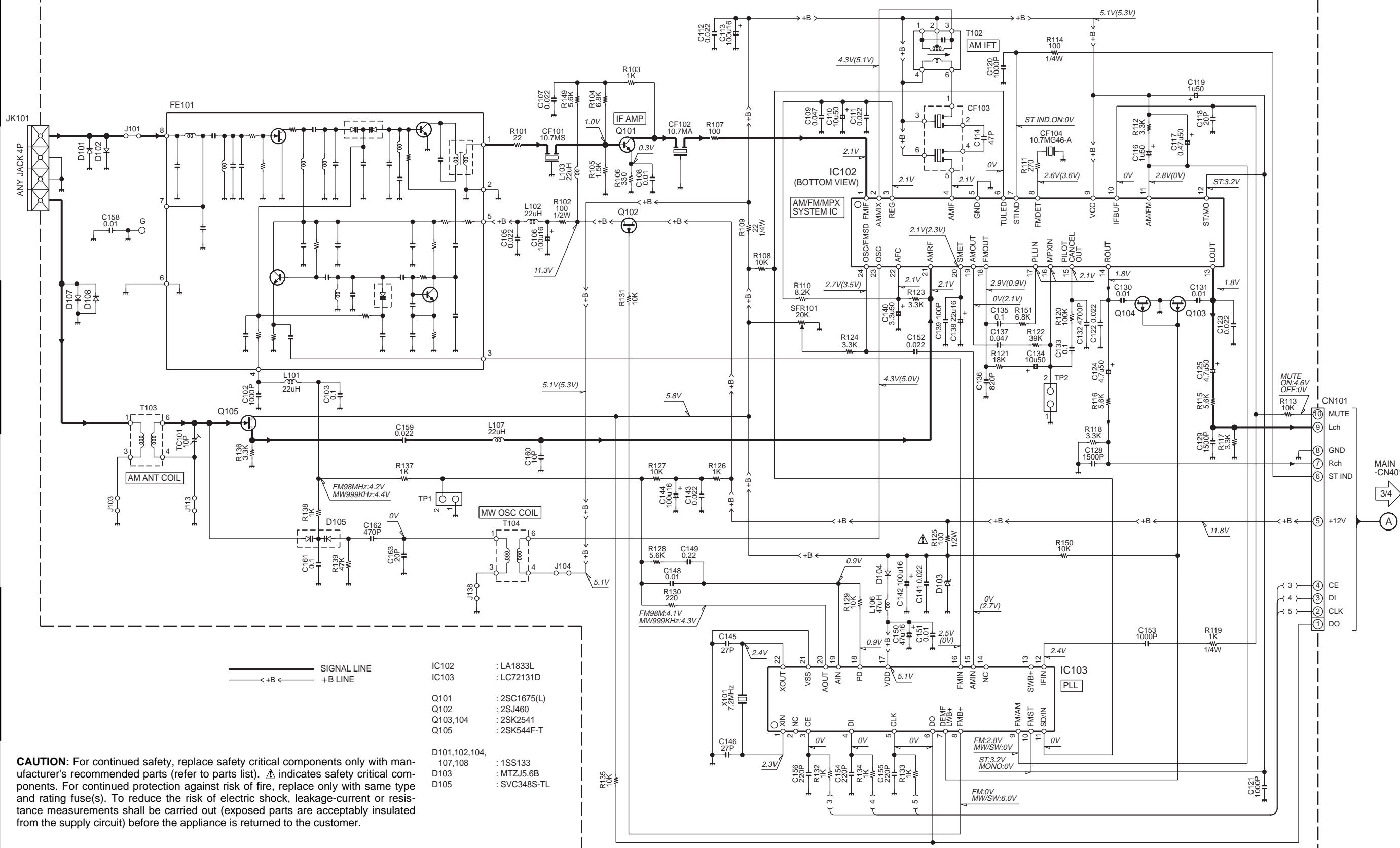

CAUTION: For continued safety, replace safety critical components only with manufacturer's recommended parts (refer to parts list). Δ indicates safety critical components. For continued protection against risk of fire, replace only with same type and rating fuse(s). To reduce the risk of electric shock, leakage-current or resistance measurements shall be carried out (exposed parts are acceptably insulated from the supply circuit) before the appliance is returned to the customer.

The DC voltage is an actual reading measured with a high impedance type voltmeter as the AM/FM signal generator is specified to the conditions as shown in the list below. The measurement value may vary depending on the measuring instruments used or on the product. The value shown in () is actual reading measured in the AM mode.

MODE	CARRIER	MODULATION		ANT INPUT
		FREQUENCY	DEVIATION	
FM	98MHz	1kHz	STEREO 67.5kHz 7.5kHz(Pilot)	60dB
AM	1000(999)kHz	400Hz	MONO 30% MOD	60dB

- IC102 : LA1833L
 IC103 : LC72131D
 Q101 : 2SC1675(L)
 Q102 : 2SJ460
 Q103,104 : 2SK2541
 Q105 : 2SK544F-T
 D101,102,104,107,108 : 1SS133
 D103 : MTZJ5.6B
 D105 : SVC348S-TL

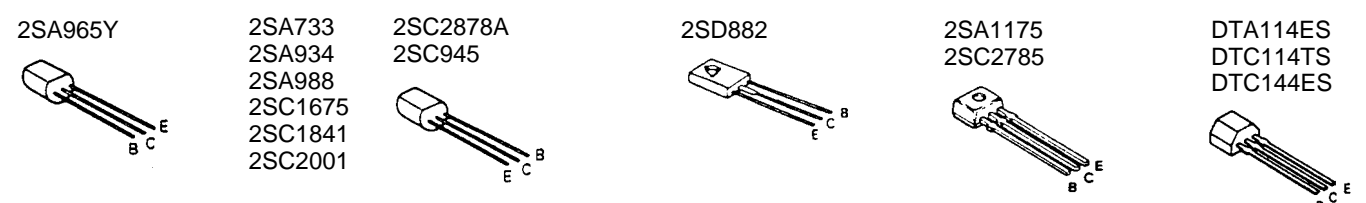

RXD-V323 (1/4)

RXD-V323

KENWOOD

Y39-3240-23

CD DECODER PCB

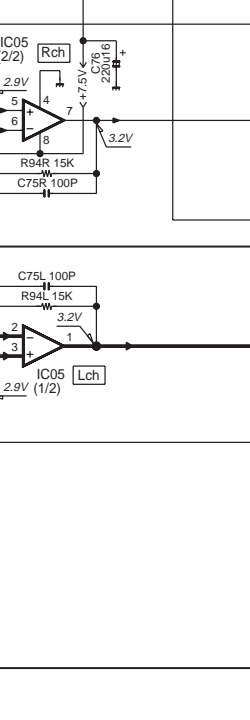
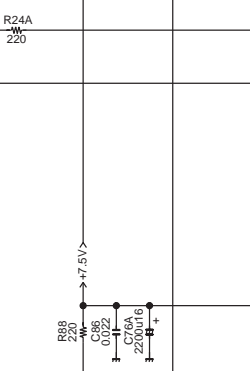
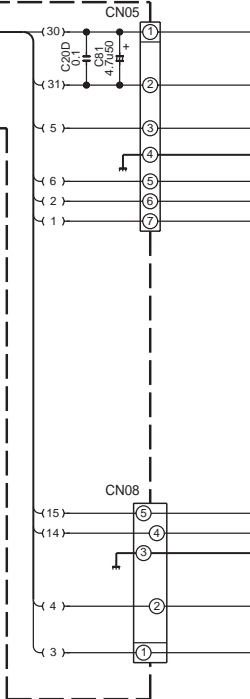
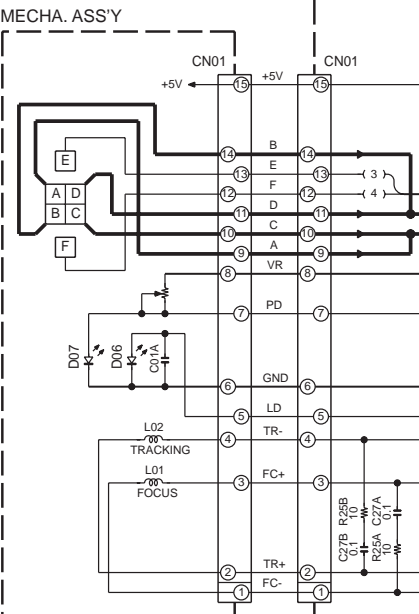
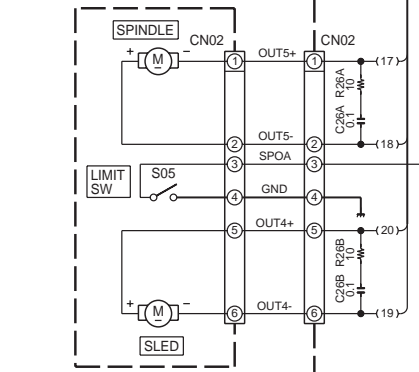
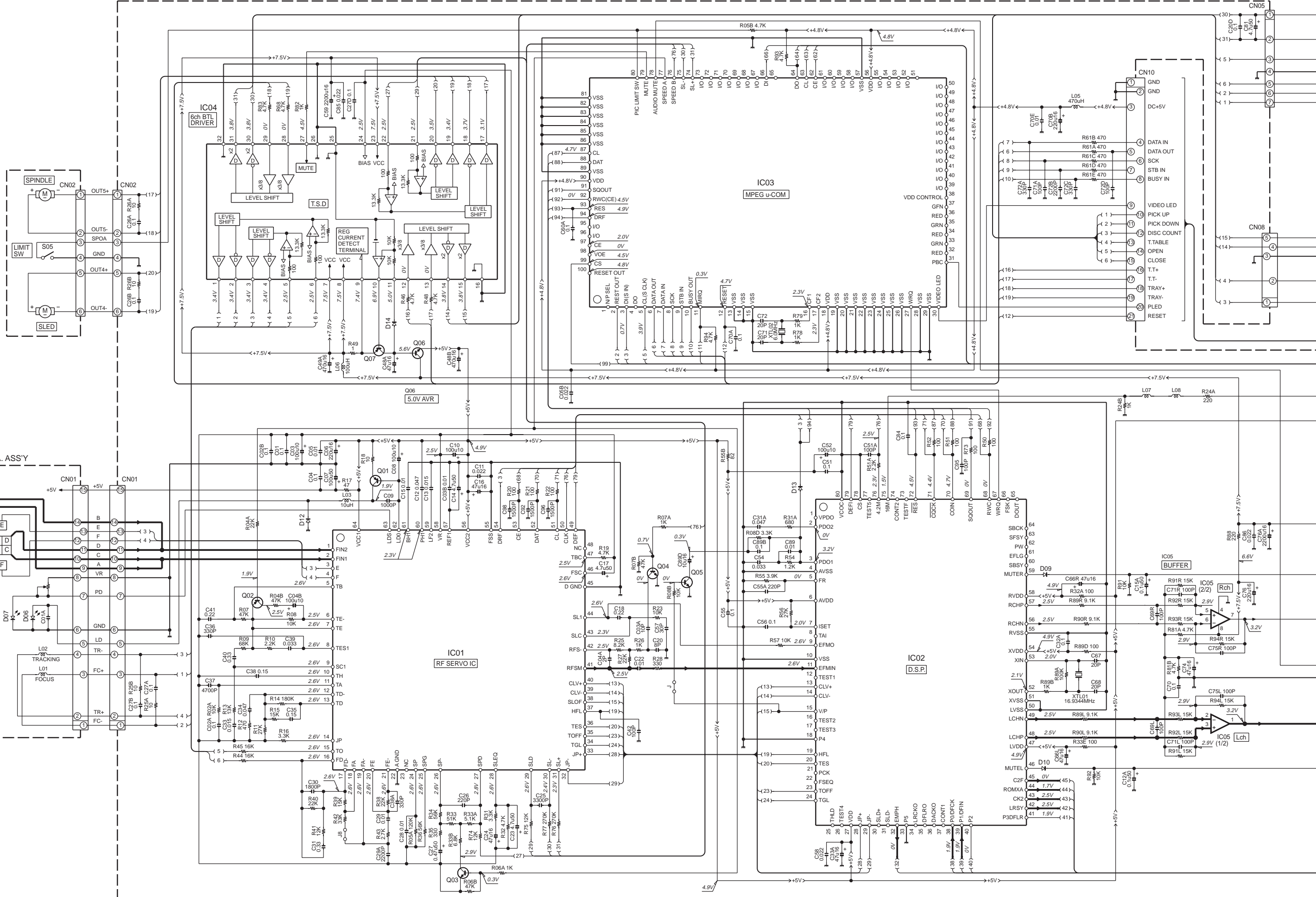

2

3

4

5

6

7

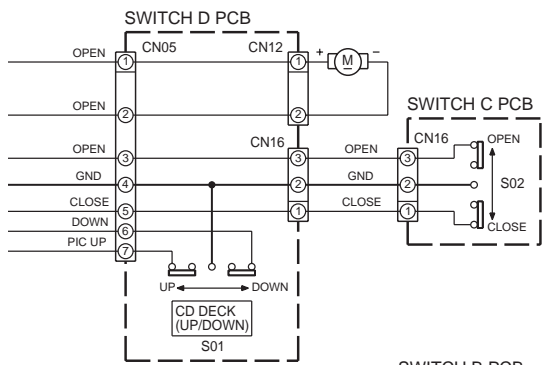

- | | | | |
|------|------------------|--------------|------------|
| IC01 | : LA9241 | Q01,02,05,07 | : 2SA952 |
| IC02 | : LC78630E | Q03,04,10,11 | : 2SC945 |
| IC03 | : LC867232A-5L82 | Q06 | : 2SD882 |
| IC04 | : BA5936S | Q12,15 | : DTA114TS |
| IC05 | : NJM4558L | Q18,19,21,22 | : 2SA1175 |
| IC06 | : BA0337/FP | Q20 | : 2SC2785 |
| IC07 | : LC7472V-SS0P24 | D09,13,18 | : 1N4148 |
| IC08 | : LC74202E | D10,12,14,17 | : 1SS133 |
| IC09 | : TC7WH04FU | | |
| IC10 | : LC32V4265T | | |

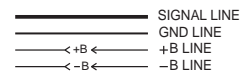

CAUTION: For continued safety, replace safety critical components only with manufacturer's recommended parts (refer to parts list). Δ indicates safety critical components. For continued protection against risk of fire, replace only with same type and rating fuse(s). To reduce the risk of electric shock, leakage-current or resistance measurements shall be carried out (exposed parts are acceptably insulated from the supply circuit) before the appliance is returned to the customer.

The DC voltage is an actual reading measured with a high impedance type voltmeter with a cassette loaded at playback mode. The measurement value may vary depending on the measuring instruments used or on the product. Bias circuit DC voltage is measured while in the record mode.

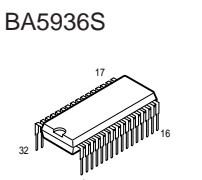
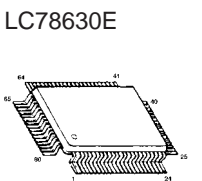
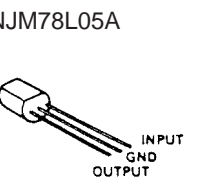
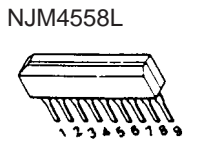
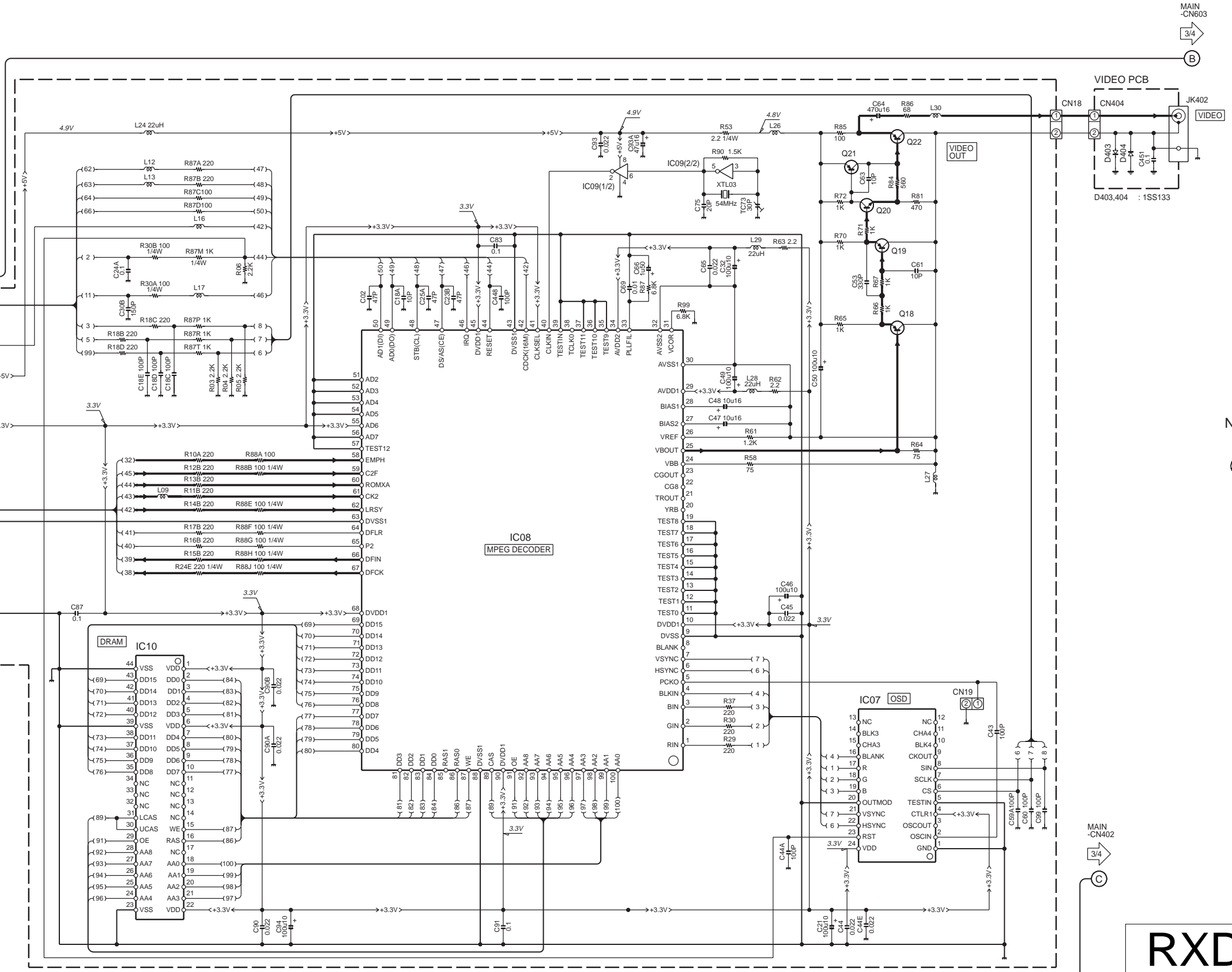
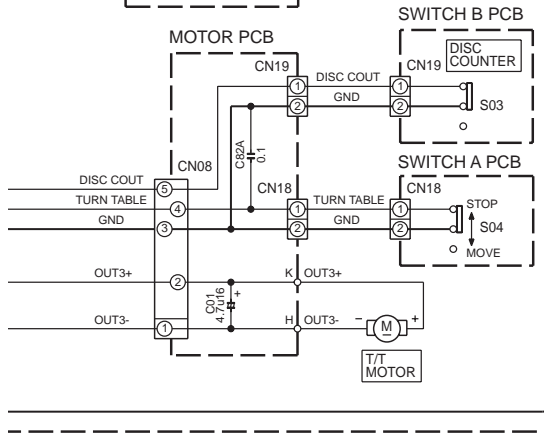

RXD-V323

KENWOOD

TUNER -CN101
1/4
A
CD DECODER -CN03
2/4
C

CASSETTE DECK MECHA. ASSY

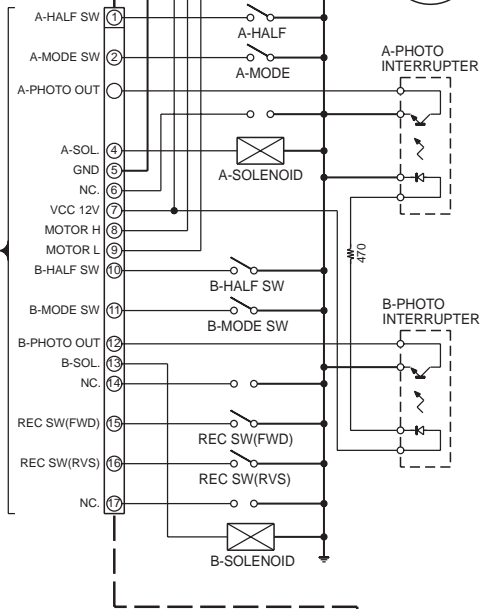

MAIN PCB

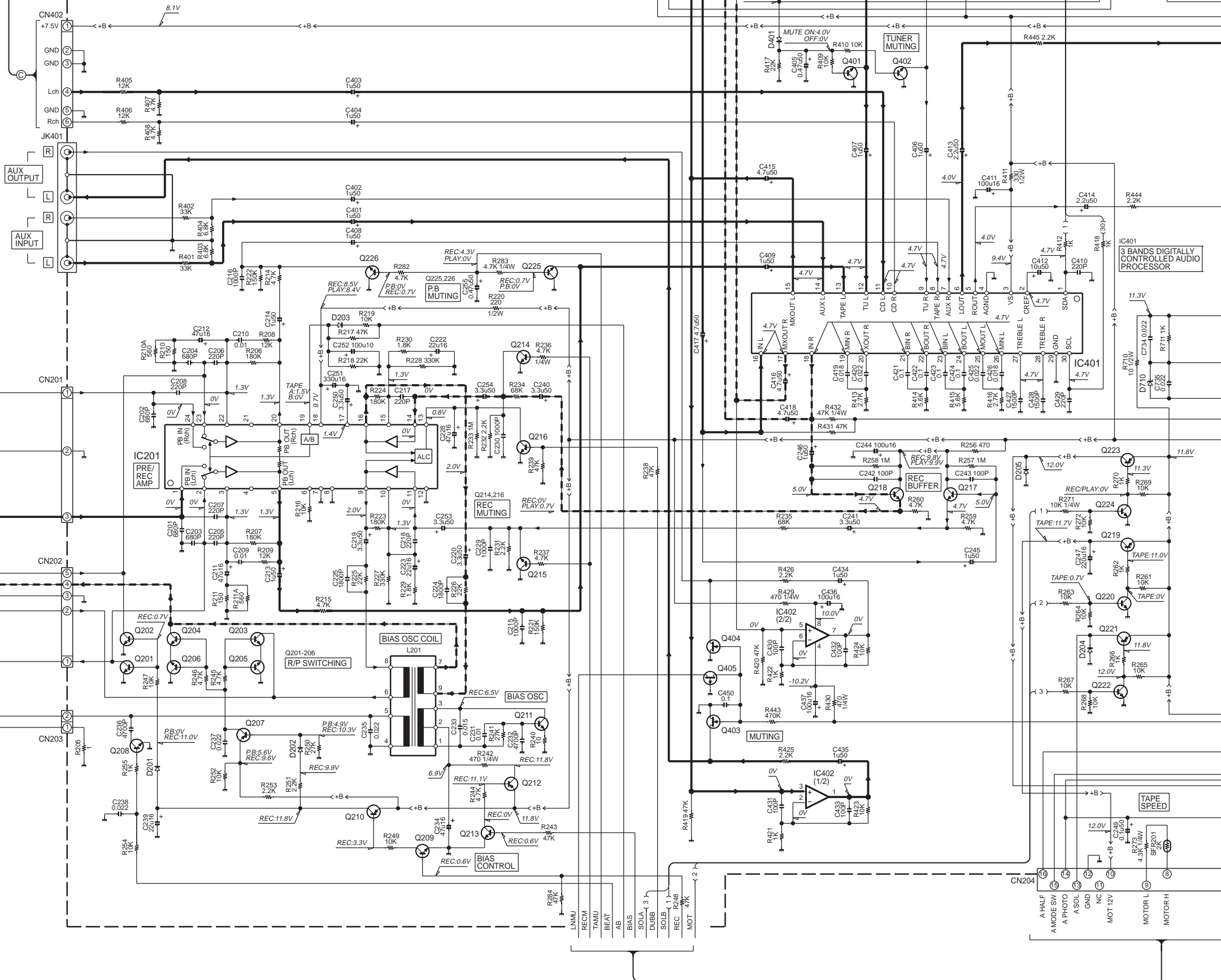

CD DECODER -CN10
2/4
B

7

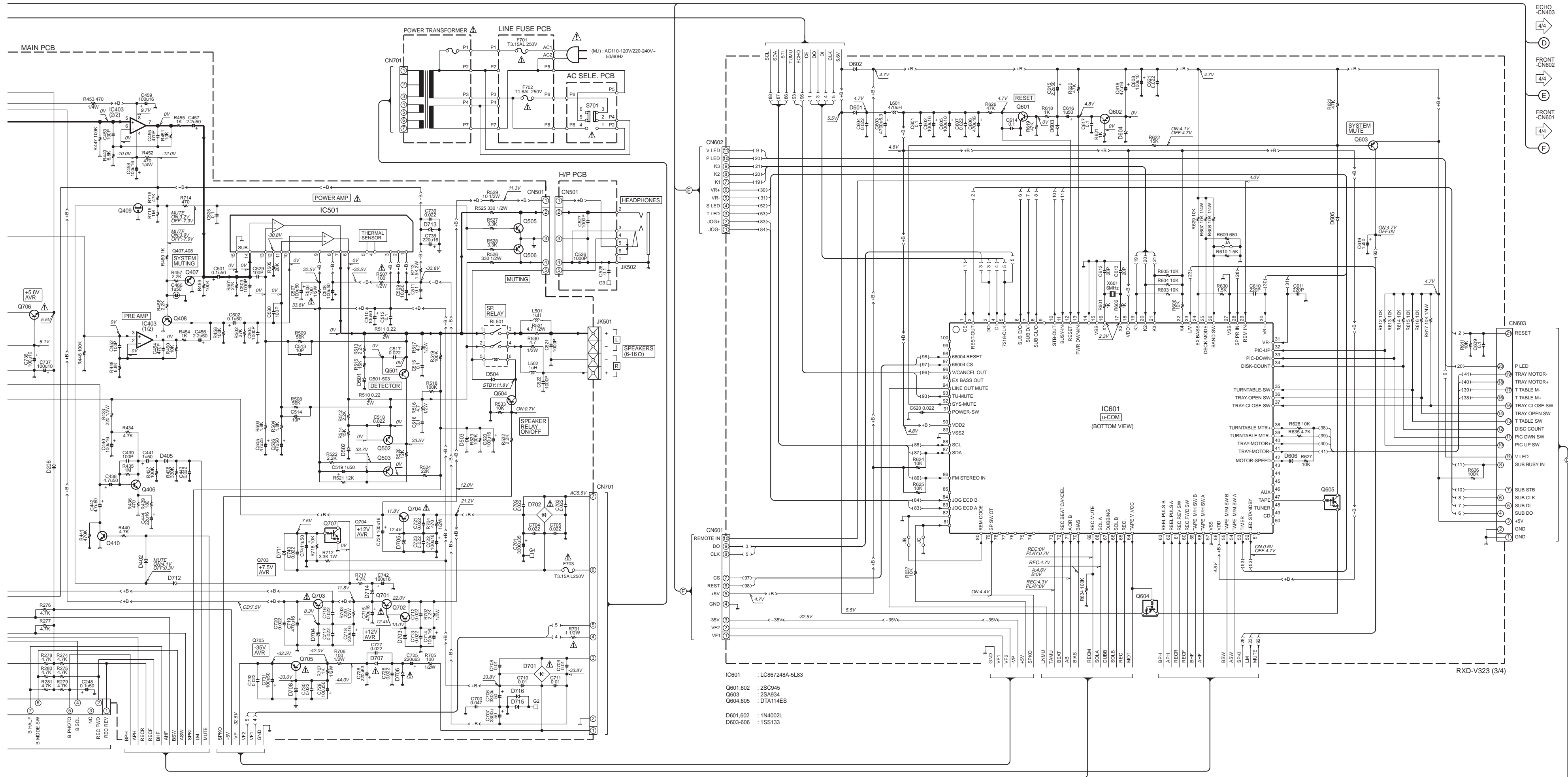

CAUTION: For continued safety, replace safety critical components only with manufacturer's recommended parts (refer to parts list). ⚠ indicates safety critical components. For continued protection against risk of fire, replace only with same type and rating fuse(s). To reduce the risk of electric shock, leakage-current or resistance measurements shall be carried out (exposed parts are acceptably insulated from the supply circuit) before the appliance is returned to the customer.

The DC voltage is an actual reading measured with a high impedance type voltmeter with a cassette loaded at playback mode. The measurement value may vary depending on the measuring instruments used or on the product. Bias circuit DC voltage is measured while in the record mode.

DOLBY and the double-D symbol are trademarks of Dolby Laboratories Licensing Corporation. Noise reduction circuit made under license from Dolby Laboratories Licensing Corporation.

- IC601 : LC867248A-5L83
 Q601,602 : 2SC945
 Q603 : 2SA934
 Q604,605 : DTA114ES
 D601,602 : 1N4002L
 D603-606 : 1SS133

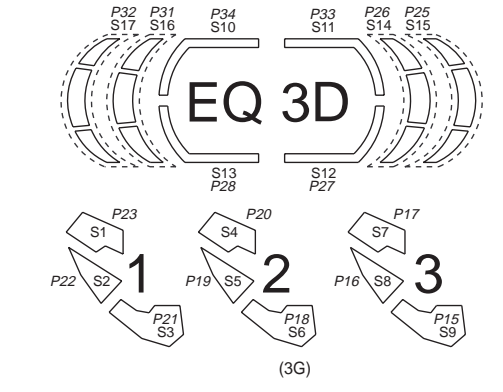
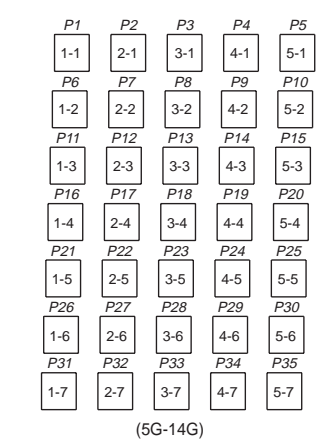
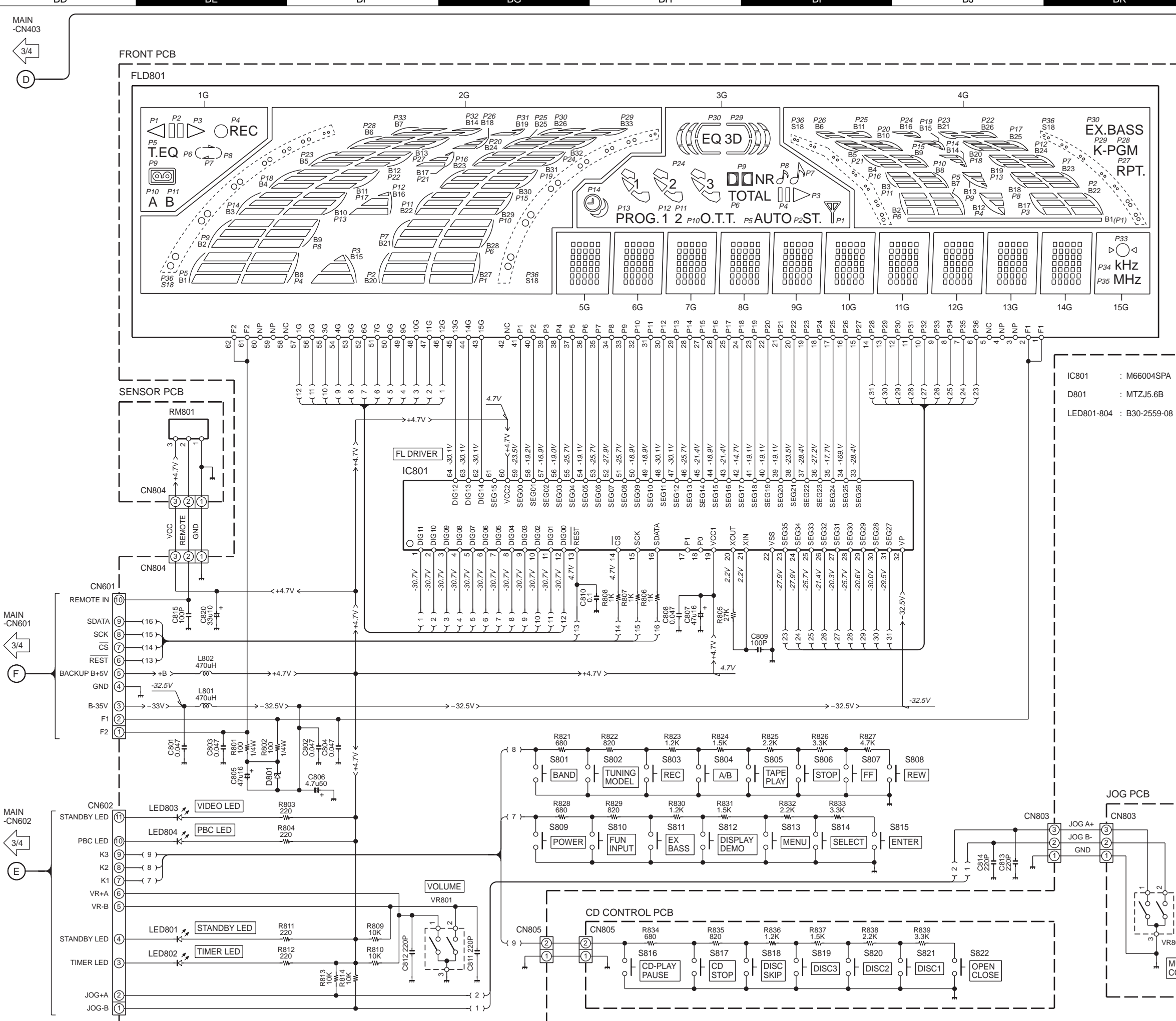

- RECORDING LINE
 - SIGNAL LINE
 - GND LINE
 - +B LINE
 - B LINE
- IC301 : TA2011S
 - IC302 : M65850P
 - IC303 : BA3837
 - IC304 : NJM78L05A
 - Q301,302 : 2SC945
 - Q303,304 : DTC114TS
 - D301 : 1N4148
 - D302 : 1SS133

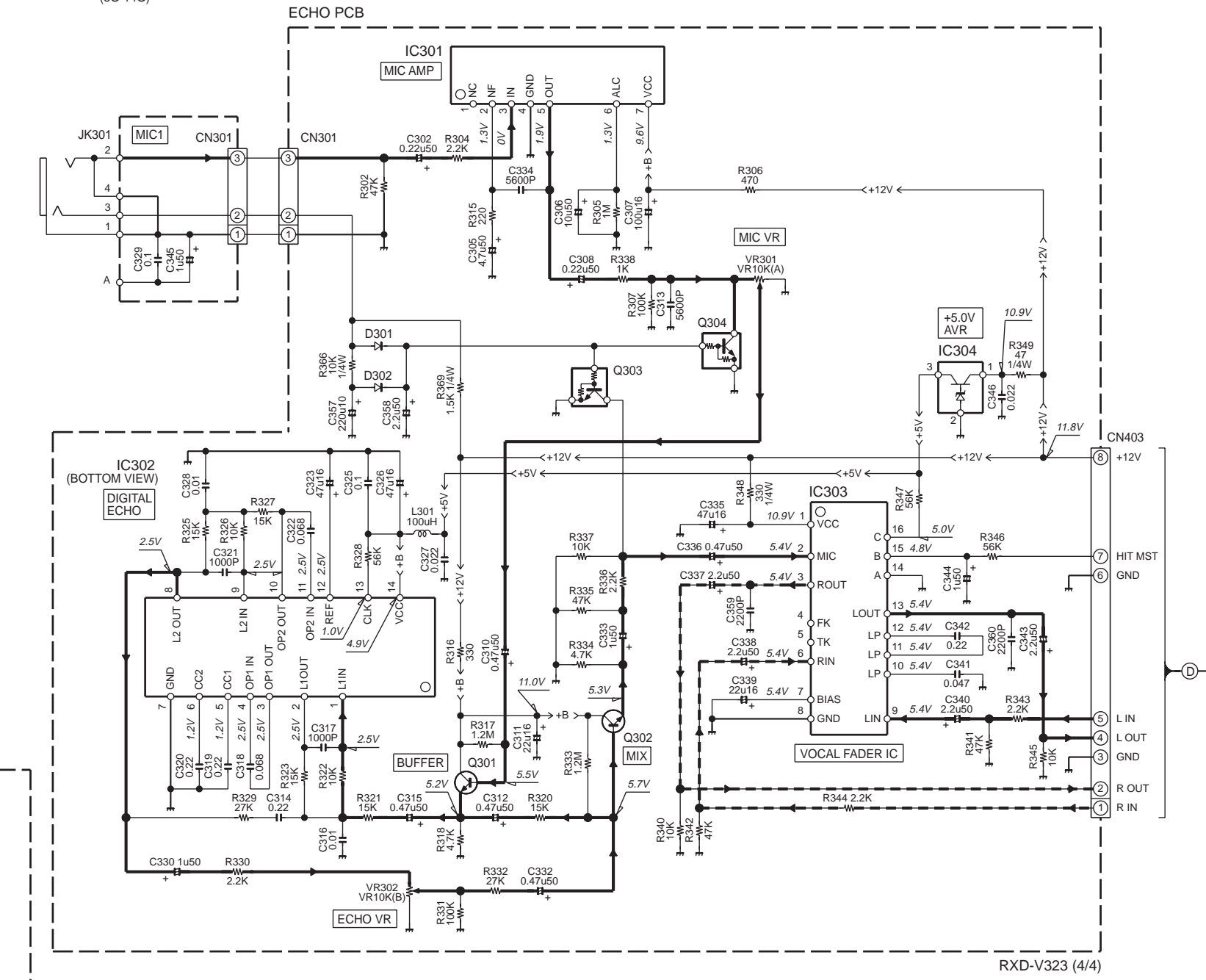

CAUTION: For continued safety, replace safety critical components only with manufacturer's recommended parts (refer to parts list). Δ indicates safety critical components. For continued protection against risk of fire, replace only with same type and rating fuse(s). To reduce the risk of electric shock, leakage-current or resistance measurements shall be carried out (exposed parts are acceptably insulated from the supply circuit) before the appliance is returned to the customer.

The DC voltage is an actual reading measured with a high impedance type voltmeter with no signal input. The measurement value may vary depending on the measuring instruments used or on the product.

EXPLODED VIEW (MECHANISM)

RXD-V323

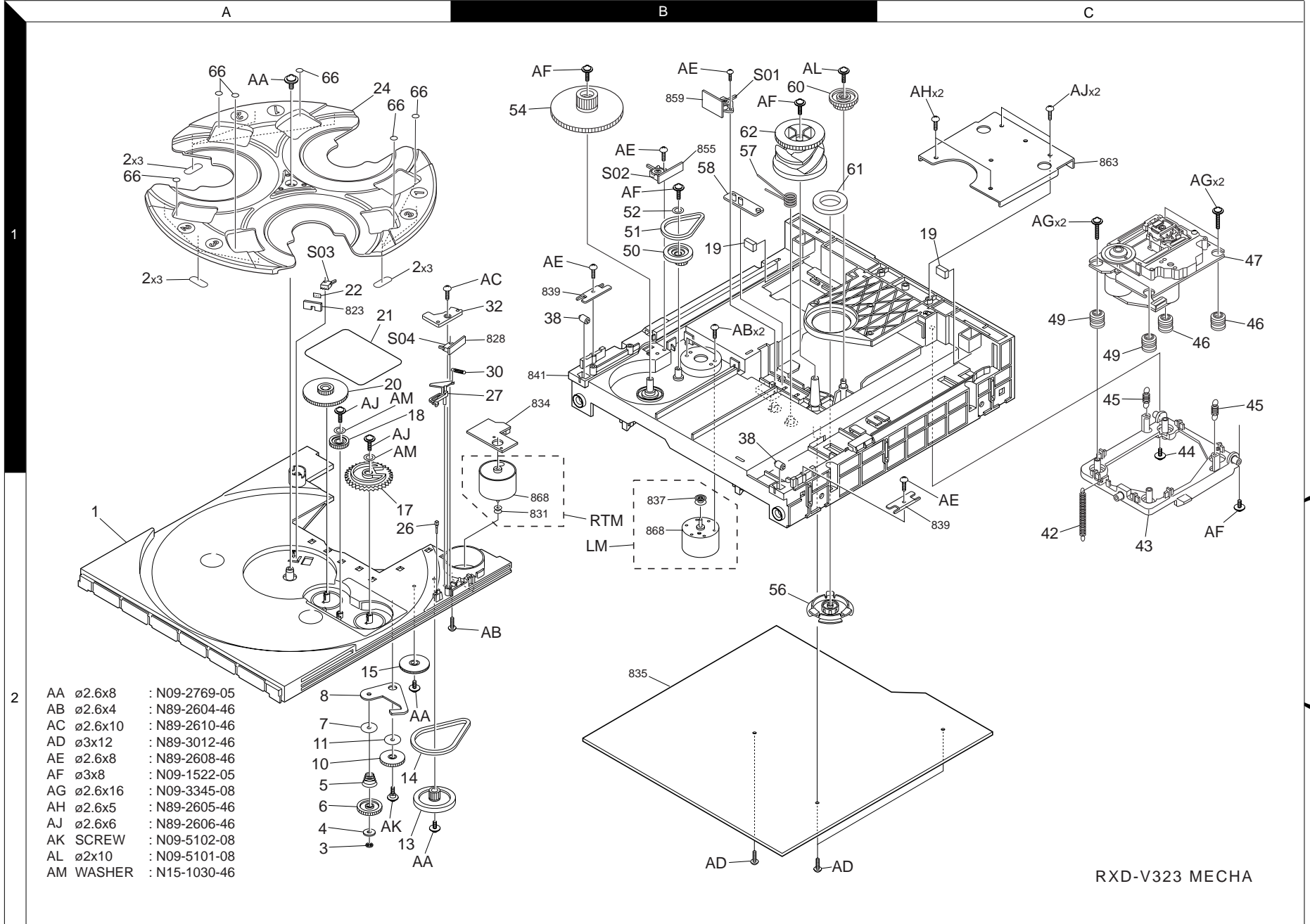

- AA \varnothing 2.6x8 : N09-2769-05
- AB \varnothing 2.6x4 : N89-2604-46
- AC \varnothing 2.6x10 : N89-2610-46
- AD \varnothing 3x12 : N89-3012-46
- AE \varnothing 2.6x8 : N89-2608-46
- AF \varnothing 3x8 : N09-1522-05
- AG \varnothing 2.6x16 : N09-3345-08
- AH \varnothing 2.6x5 : N89-2605-46
- AJ \varnothing 2.6x6 : N89-2606-46
- AK SCREW : N09-5102-08
- AL \varnothing 2x10 : N09-5101-08
- AM WASHER : N15-1030-46

RXD-V323 MECHA

- A \varnothing 3x12 : N09-1960-05
- B \varnothing 3x10 : N89-3010-41
- C \varnothing 3x8 : N82-3008-46
- D M3x8(BLK) : N35-3008-45
- E \varnothing 3x6(BLK) : N89-3006-45
- F \varnothing 3x10(BLK) : N89-3010-45
- G \varnothing 3x10 : N89-3010-46
- H \varnothing 3x8 : N89-3008-46
- J M4x6 : N09-1396-05
- K \varnothing 3x6 : N89-3006-46
- L \varnothing 3x12 : N89-3012-46
- M E-RING : N19-1498-08
- N \varnothing 3x8 : N09-1515-05
- P Push Rivet : N29-0035-05
- Q WASHER : N15-1040-46
- R WASHER : N19-1367-05

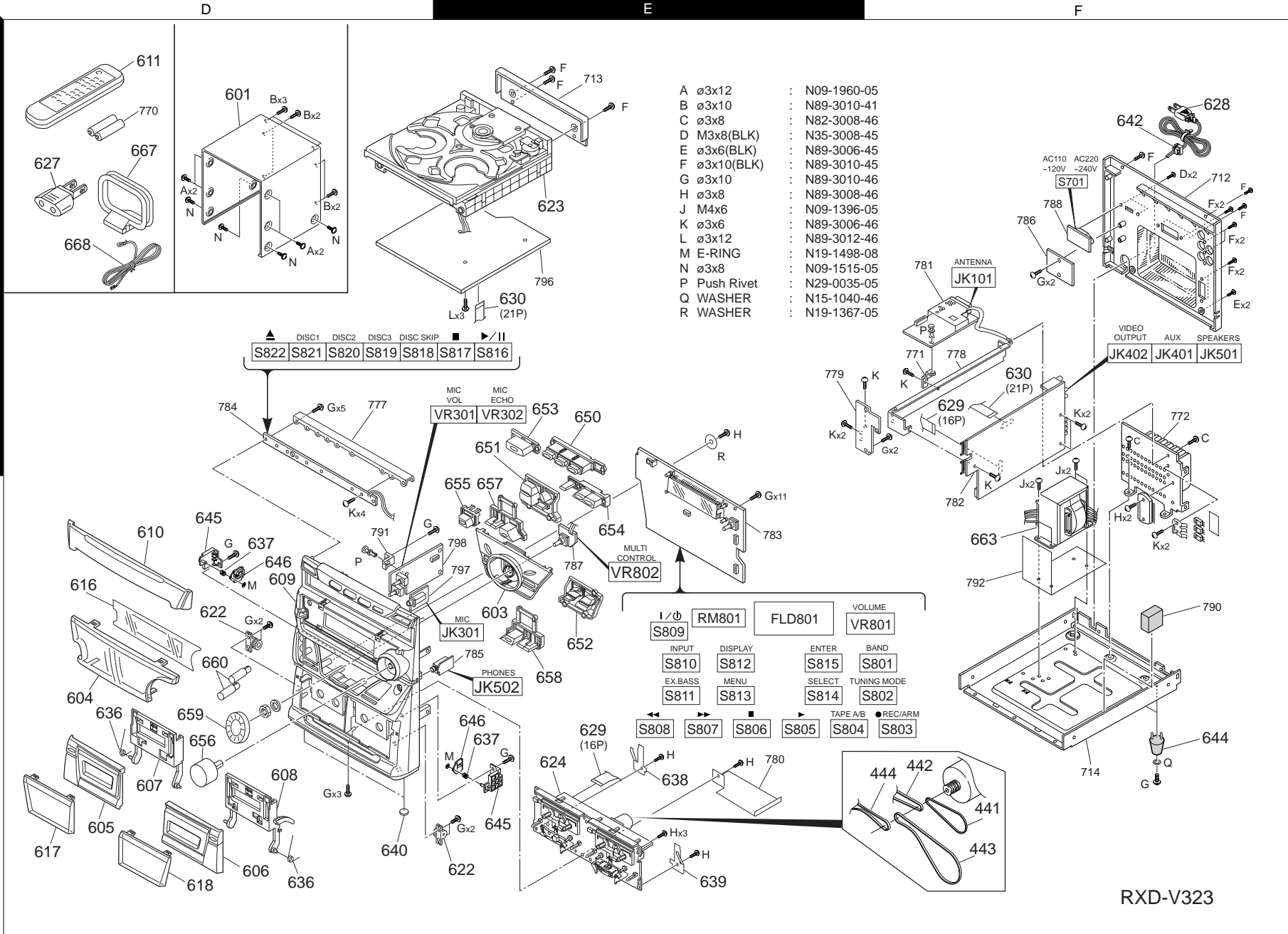

Parts with exploded view numbers larger than 700 are not supplied.

* New Parts

Parts without **Parts No.** are not supplied.
 Les articles non mentionnés dans le **Parts No.** ne sont pas fournis.
 Teile ohne **Parts No.** werden nicht geliefert.

①

Ref. No	Add-ress	New Parts	Parts No.	Description	Desti-nation	Re-marks
RXD-V323						
601	1D	*	A01-3711-08	TOP COVER(METAL)	100227984V	
603	2E		A22-1831-08	CONTROL PLATE	100207994S	
604	2D	*	A29-1083-08	FRONT WINDOW	100207994V	
605	2D		A53-2158-08	CASS. DOOR L	100507994S	
606	2D		A53-2159-08	CASS. DOOR R	100607994S	
607	2D	*	A53-2162-18	CASS.HOLDER L	200117994S	
608	2D	*	A53-2163-18	CASS.HOLDER R	200217994S	
609	2D	*	A60-1722-18	FRONT PANEL	100117994V	
610	2D		A60-1751-08	CD DOOR	100407994V	
611	1D		A70-1321-08	REMOTE CONT	715994V087	
616	2D	*	A29-1074-08	DISPLAY WNDW	100607994V	
617	2D		B10-3527-08	CASS. WINDOW L	100707994S	
618	2D		B10-3528-08	CASS. WINDOW R	100807994S	
622	2D,2E		D39-0325-08	GEAR DAMPER	200000126S	
623	1E	*	D40-1664-08	CD MECHA.ASSY	920F-C2	
624	2E		D40-1653-08	CASS.DECK CWL	4380605270	
627	1D		E03-0115-05	AC ADAPTER	4570901650	
628	1F		E30-0459-05	AC CORD	463221W065	
629	1E,1F	*	E35-2477-08	FFC 16P(240mm)	5421624100	
630	1E,1F	*	E35-2479-08	FFC 21P(200mm)	5422120100	
636	2D		G01-4155-08	EJECT SPRING	201007994S	
637	2D,2E		G01-4156-08	SPRING	2A20A79880	
638	2E		G02-1686-08	SPRING PLATE(L)	201507994S	
639	2E		G02-1687-08	SPRING PLATE(R)	201607994S	
640	2D		G11-2484-08	FOOT RUBBER	2M994S0010	
642	1F		J42-0330-08	CORD STOPPER	4580000021	
644	2F	*	J02-1458-08	FOOT(REAR)	100507994V	
645	2D,2E	*	J19-6047-08	EJECT HOLDER ASSY	0K01B7988B	
646	2D,2E	*	J19-6048-08	EJECT LEVER	2A16E79880	
650	1E		K29-7641-08	DISC BUT BASE ASSY	.003107994S	
651	1E		K29-7642-08	EX BASS BUT ASSY	.003207994S	
652	2E		K29-7643-08	TUNING BUT ASSY	003307994S	
653	1E		K29-7646-08	OPE/CLOSE BUT	100907994S	
654	2E		K29-7648-08	PLAY/PAUSE BUT,	101007994S	
655	2E	*	K29-7715-08	POWER BUTTON	103107994S	
656	2D		K29-7652-08	VOLUME KNOB	101707994S	
657	2E		K29-7654-08	STOP BUTTON	102207994S	
658	2E		K29-7656-08	PLAY BUTTON	102307994S	
659	2D		K29-7658-08	JOG KNOB	102607994S	
660	2D	*	K29-7713-08	MIC VOL KNOB	101607994S	
663	2F	*	L07-2780-08	POWER TRANS	420F769123	
667	1D		T90-0815-08	AM LOOP ANT	4300103380	
668	1D		T90-0847-08	FM ANTENNA	4591500275	
-			B60-4315-08	INST. MAN(EN)	9080025160	
-			B60-4316-08	INST. MAN(TC)	9080025170	
-			B60-4317-08	INST. MAN(ES)	9080025180	
-		*	H10-7612-18	SNOW BOX L	900117994S	
-		*	H10-7613-18	SNOW BOX R	900217994S	
-		*	H21-0366-08	SOFT SHEET(150X70)	9004079840	
-		*	H50-3406-08	MASTER CARTON	901907994V	
-			J19-5813-08	BIND TYPEA	2000000144	
-			9100022010	MADE IN M'SAI LABEL		
-			9100022410	POP LABEL(L/R)	9100022410	

L : Scandinavia K : USA P : Canada R : Mexico C : China I : Malaysia

Y : PX(Far East, Hawaii) T : England E : Europe G : Germany V : China (Shanghai)

Y : AAFES(Europe) X : Australia Q : Russia H : Korea M : Other Areas Δ indicates safety critical components.

* New Parts

Parts without **Parts No.** are not supplied.
 Les articles non mentionnés dans le **Parts No.** ne sont pas fournis.
 Teile ohne **Parts No.** werden nicht geliefert.

②

Ref. No	Add-ress	New Parts	Parts No.	Description	Desti-nation	Re-marks
-			9902304049	INST. BAG	9902304049	
M			N19-1498-08	E-RING		
ELECTRIC PARTS						
LED801-804			B30-2559-08	LED,LTL-87HCE	4120687HCE	
C01			CK45FB1H104Z	CERAMIC	0.10UF	Z
C02			C91-0737-05	CERAMIC	47PF	J
C02A			CQ92FM1H104J	MYLAR	0.10UF	J
C02B			CK45FB1H104Z	CERAMIC	0.10UF	Z
C03			CE04KW1A101M	ELECTRO	100UF	10WV
C03A			CC45FCH1H100J	CERAMIC	10PF	J
C03B			C91-0769-05	CERAMIC	0.010UF	K
C04			CK45FB1H104Z	CERAMIC	0.10UF	Z
C04A			CC45FCH1H020C	CERAMIC	2.0PF	C
C04B			CE04KW1A101M	ELECTRO	100UF	10WV
C05			C91-0769-05	CERAMIC	0.010UF	K
C05B			C91-0085-05	CERAMIC	0.022UF	N
C06			CE04KW1C221M	ELECTRO	220UF	16WV
C06A			CE04KW1C470M	ELECTRO	47UF	16WV
C06B			C91-0085-05	CERAMIC	0.022UF	N
C06D			CE04KW1A101M	ELECTRO	100UF	10WV
C06E			C91-0085-05	CERAMIC	0.022UF	N
C07			CE04KW1H101M	ELECTRO	100UF	50WV
C08			CE04KW1A101M	ELECTRO	100UF	10WV
C09			C91-0757-05	CERAMIC	1000PF	K
C10			CE04KW1A101M	ELECTRO	100UF	10WV
C11			C91-0085-05	CERAMIC	0.022UF	N
C12			CQ92FM1H473J	MYLAR	0.047UF	J
C12A			CE04KW1H0R1M	ELECTRO	0.1UF	50WV
C13			CQ92FM1H153J	MYLAR	0.015UF	J
C14			CE04KW1H4R7M	ELECTRO	4.7UF	50WV
C15			CQ92FM1H103J	MYLAR	0.010UF	J
C15A			CE04KW1H0R1M	ELECTRO	0.1UF	50WV
C16			CE04KW1C470M	ELECTRO	47UF	16WV
C17			CE04KW1H4R7M	ELECTRO	4.7UF	50WV
C18			CQ93FMG1H224J	MYLAR	0.22UF	J
C18A			C91-0721-05	CERAMIC	10PF	J
C18C-E			C91-0745-05	CERAMIC	100PF	K
C20			CC45FSL1H080DM	CERAMIC	8.0PF	D
C20D			C91-1525-08	CERAMIC	0.1UF	Z
C21			CE04KW1A101M	ELECTRO	100UF	10WV
C22			C91-0769-05	CERAMIC	0.010UF	K
C23			CE04KW1H4R7M	ELECTRO	4.7UF	50WV
C23B			C91-0737-05	CERAMIC	47PF	J
C24			CE04KW1C470M	ELECTRO	47UF	16WV
C24A			CK45FB1H104K	CERAMIC	0.10UF	K
C25			C91-0763-05	CERAMIC	3300PF	M
C25A			C91-0737-05	CERAMIC	47PF	J
C26			C91-0749-05	CERAMIC	220PF	K
C26A/B			CK45FB1H104Z	CERAMIC	0.10UF	Z
C27			CE04KW1HR47M	ELECTRO	0.47UF	50WV
C27A/B			CK45FB1H104Z	CERAMIC	0.10UF	Z
C27D			CK45FB1H104Z	CERAMIC	0.10UF	Z
C28			C91-0769-05	CERAMIC	0.010UF	K

L : Scandinavia K : USA P : Canada R : Mexico C : China I : Malaysia

Y : PX(Far East, Hawaii) T : England E : Europe G : Germany V : China (Shanghai)

Y : AAFES(Europe) X : Australia Q : Russia H : Korea M : Other Areas Δ indicates safety critical components.

* New Parts
Parts without **Parts No.** are not supplied.
Les articles non mentionnés dans le **Parts No.** ne sont pas fournis.
Teile ohne **Parts No.** werden nicht geliefert.

3

Ref. No	Add-ress	New Parts	Parts No.	Description	Desti-nation	Re-marks
C29			CQ92FM1H103J	MYLAR 0.010UF	J	
C29A			CQ92FM1H222J	MYLAR 2200PF	J	
C30			CK45FB1C182K	CERAMIC 1800PF	K	
C30B			C91-0747-05	CERAMIC 150PF	K	
C31			CQ92FM1H334K	MYLAR 0.33UF	K	
C31A			CK45FF1H473Z	CERAMIC 0.047UF	Z	
C32			CE04KW1A101M	ELECTRO 100UF	10WV	
C32A			CK45FB1H104Z	CERAMIC 0.10UF	Z	
C33			CQ92FM1H153J	MYLAR 0.015UF	J	
C33A			CE04KW1C470M	ELECTRO 47UF	16WV	
C34			CQ92FM1H473J	MYLAR 0.047UF	J	
C35			CQ92FM1H154J	MYLAR 0.15UF	J	
C36			C91-0751-05	CERAMIC 330PF	K	
C37			CQ92FM1H472J	MYLAR 4700PF	J	
C38			CQ93FMG1H154J	MYLAR 0.15UF	J	
C38A			C91-0751-05	CERAMIC 330PF	K	
C39			CQ92FM1H333J	MYLAR 0.033UF	J	
C40			CQ92FM1H334K	MYLAR 0.33UF	K	
C41			CQ93FMG1H224J	MYLAR 0.22UF	J	
C42 ,43			C91-0745-05	CERAMIC 100PF	K	
C44			C91-0085-05	CERAMIC 0.022UF	N	
C44A/B			C91-0745-05	CERAMIC 100PF	K	
C44E			C91-0085-05	CERAMIC 0.022UF	N	
C45			C91-0085-05	CERAMIC 0.022UF	N	
C46			CE04KW1A101M	ELECTRO 100UF	10WV	
C47 ,48			CE04KW1C100M	ELECTRO 10UF	16WV	
C48A			CE04KW1C470M	ELECTRO 47UF	16WV	
C48B			CE04KW1C471M	ELECTRO 470UF	16WV	
C49 ,50			CE04KW1A101M	ELECTRO 100UF	10WV	
C49A			CE04KW1C471M	ELECTRO 470UF	16WV	
C51			CK45FB1H104Z	CERAMIC 0.10UF	Z	
C51A			C91-0745-05	CERAMIC 100PF	K	
C52			CE04KW1A101M	ELECTRO 100UF	10WV	
C53			C91-0751-05	CERAMIC 330PF	K	
C54			CQ92FM1H333J	MYLAR 0.033UF	J	
C55			CK45FB1H104Z	CERAMIC 0.10UF	Z	
C55A			C91-0749-05	CERAMIC 220PF	K	
C56			CK45FB1H104K	CERAMIC 0.10UF	K	
C57			CC45FCH1H300J	CERAMIC 30PF	J	
C58			C91-0085-05	CERAMIC 0.022UF	N	
C59			CE04KW1C222M	ELECTRO 2200UF	16WV	
C59A			C91-0745-05	CERAMIC 100PF	K	
C60			C91-0745-05	CERAMIC 100PF	K	
C60A			CK45FB1H104K	CERAMIC 0.10UF	K	
C61			CC45FCH1H100J	CERAMIC 10PF	J	
C63			CC45FCH1H100J	CERAMIC 10PF	J	
C64			CE04KW1C471M	ELECTRO 470UF	16WV	
C65			C91-0085-05	CERAMIC 0.022UF	N	
C66			CE04KW1H010M	ELECTRO 1.0UF	50WV	
C66L/R			CE04KW1C470M	ELECTRO 47UF	16WV	
C67 ,68			CC45FCH1H200J	CERAMIC 20PF	J	
C69			C91-0769-05	CERAMIC 0.010UF	K	
C69L/R			C91-0745-05	CERAMIC 100PF	K	
C70			CK45FB1H104Z	CERAMIC 0.10UF	Z	
C70A			CK45FB1H104K	CERAMIC 0.10UF	K	

L : Scandinavia K : USA P : Canada R : Mexico C : China I : Malaysia
Y : PX(Far East, Hawaii) T : England E : Europe G : Germany V : China (Shanghai)
Y : AAFES(Europe) X : Australia Q : Russia H : Korea M : Other Areas Δ indicates safety critical components.

* New Parts
Parts without **Parts No.** are not supplied.
Les articles non mentionnés dans le **Parts No.** ne sont pas fournis.
Teile ohne **Parts No.** werden nicht geliefert.

4

Ref. No	Add-ress	New Parts	Parts No.	Description	Desti-nation	Re-marks
C70B			CE04KW1C221M	ELECTRO 220UF	16WV	
C70E			C91-0769-05	CERAMIC 0.010UF	K	
C71 ,72			CC45FCH1H200J	CERAMIC 20PF	J	
C71A			C91-0745-05	CERAMIC 100PF	K	
C71L/R			C91-0745-05	CERAMIC 100PF	K	
C72A			C91-0751-05	CERAMIC 330PF	K	
C72B			C91-0761-05	CERAMIC 2200PF	M	
C72C			C91-0751-05	CERAMIC 330PF	K	
C72D			C91-0745-05	CERAMIC 100PF	K	
C74			CE04KW1C470M	ELECTRO 47UF	16WV	
C75			CC45FCH1H200J	CERAMIC 20PF	J	
C75L/R			C91-0745-05	CERAMIC 100PF	K	
C76			CE04KW1C221M	ELECTRO 220UF	16WV	
C76A			CE04KW1C222M	ELECTRO 2200UF	16WV	
C77 ,78			CE04KW1H2R2M	ELECTRO 2.2UF	50WV	
C79 ,80			C91-0745-05	CERAMIC 100PF	K	
C81			CE04BP1H4R7M	NP-ELEC 4.7UF	50WV	
C83			CK45FB1H104Z	CERAMIC 0.10UF	Z	
C84			CK45FB1H104K	CERAMIC 0.10UF	K	
C85 ,86			C91-0085-05	CERAMIC 0.022UF	N	
C87 ,88			CK45FB1H104Z	CERAMIC 0.10UF	Z	
C89			C91-0769-05	CERAMIC 0.010UF	K	
C89B			CK45FB1H104K	CERAMIC 0.10UF	K	
C89D			CE04KW1C100M	ELECTRO 10UF	16WV	
C90			C91-0085-05	CERAMIC 0.022UF	N	
C90A/B			C91-0085-05	CERAMIC 0.022UF	N	
C91			CK45FB1H104Z	CERAMIC 0.10UF	Z	
C92			C91-0759-05	CERAMIC 1500PF	M	
C93			C91-0085-05	CERAMIC 0.022UF	N	
C93A			CE04KW1C470M	ELECTRO 47UF	16WV	
C94			CE04KW1A101M	ELECTRO 100UF	10WV	
C95			C91-0745-05	CERAMIC 100PF	K	
C96			C91-0759-05	CERAMIC 1500PF	M	
C98			C91-0759-05	CERAMIC 1500PF	M	
C99			C91-0745-05	CERAMIC 100PF	K	
C102			C91-0757-05	CERAMIC 1000PF	K	
C103			CK45FB1H104Z	CERAMIC 0.10UF	Z	
C105			C91-0085-05	CERAMIC 0.022UF	N	
C106			CE04KW1C101M	ELECTRO 100UF	16WV	
C107			C91-0085-05	CERAMIC 0.022UF	N	
C108			CQ92FM1H103J	MYLAR 0.010UF	J	
C109			CK45FB1H473Z	CERAMIC 0.047UF	Z	
C110			CE04KW1H100M	ELECTRO 10UF	50WV	
C111,112			C91-0085-05	CERAMIC 0.022UF	N	
C113			CE04KW1C101M	ELECTRO 100UF	16WV	
C114			C91-0737-05	CERAMIC 47PF	J	
C116			CE04KW1H010M	ELECTRO 1.0UF	50WV	
C117			CE04KW1HR47M	ELECTRO 0.47UF	50WV	
C118			CC45FCH1H200J	CERAMIC 20PF	J	
C119			CE04KW1H010M	ELECTRO 1.0UF	50WV	
C120,121			C91-0757-05	CERAMIC 1000PF	K	
C122,123			CQ92FM1H223J	MYLAR 0.022UF	J	
C124,125			CE04KW1H4R7M	ELECTRO 4.7UF	50WV	
C128,129			CQ92FM1H152J	MYLAR 1500PF	J	
C130,131			CQ92FM1H103J	MYLAR 0.010UF	J	

L : Scandinavia K : USA P : Canada R : Mexico C : China I : Malaysia
Y : PX(Far East, Hawaii) T : England E : Europe G : Germany V : China (Shanghai)
Y : AAFES(Europe) X : Australia Q : Russia H : Korea M : Other Areas Δ indicates safety critical components.

* New Parts

Parts without **Parts No.** are not supplied.
Les articles non mentionnés dans le **Parts No.** ne sont pas fournis.
Teile ohne **Parts No.** werden nicht geliefert.

5

Ref. No	Add-ress	New Parts	Parts No.	Description	Desti-nation	Re-marks
C132			C91-0765-05	CERAMIC 4700PF	J	
C133			CK45FB1H104Z	CERAMIC 0.10UF	Z	
C134			CE04KW1H100M	ELECTRO 10UF	50WV	
C135			CK45FB1H104Z	CERAMIC 0.10UF	Z	
C136			C91-0756-05	CERAMIC 820PF	K	
C137			CK45FB1H473Z	CERAMIC 0.047UF	Z	
C138			CE04KW1C220M	ELECTRO 22UF	16WV	
C139			C91-0745-05	CERAMIC 100PF	K	
C140			CE04KW1H3R3M	ELECTRO 3.3UF	50WV	
C141			C91-0085-05	CERAMIC 0.022UF	N	
C142			CE04KW1C101M	ELECTRO 100UF	16WV	
C143			C91-0085-05	CERAMIC 0.022UF	N	
C144			CE04KW1C101M	ELECTRO 100UF	16WV	
C145,146			CC45FCH1H270J	CERAMIC 27PF	J	
C148			CQ92FM1H103J	MYLAR 0.010UF	J	
C149			CQ93FMG1H224J	MYLAR 0.22UF	J	
C150			CE04KW1C470M	ELECTRO 47UF	16WV	
C151			C91-0769-05	CERAMIC 0.010UF	K	
C152			C91-0085-05	CERAMIC 0.022UF	N	
C153			C91-0757-05	CERAMIC 1000PF	K	
C154-156			C91-0749-05	CERAMIC 220PF	K	
C158			C91-0769-05	CERAMIC 0.010UF	K	
C159			C91-0085-05	CERAMIC 0.022UF	N	
C160			C91-0721-05	CERAMIC 10PF	J	
C161			CK45FB1H104Z	CERAMIC 0.10UF	Z	
C162			CF92FV1H471J	MF-C 470PF	J	
C163			CC45FCH1H200J	CERAMIC 20PF	J	
C201-204			C91-0755-05	CERAMIC 680PF	K	
C205-208			C91-0749-05	CERAMIC 220PF	K	
C209,210			CK45FB1H103K	CERAMIC 0.010UF	K	
C211,212			CE04KW1C470M	ELECTRO 47UF	16WV	
C213,214			CE04KW1H010M	ELECTRO 1.0UF	50WV	
C215,216			C91-0757-05	CERAMIC 1000PF	K	
C217,218			C91-0749-05	CERAMIC 220PF	K	
C219,220			CE04KW1H3R3M	ELECTRO 3.3UF	50WV	
C222,223			CE04KW1C220M	ELECTRO 22UF	16WV	
C224,225			CK45FB1H182K	CERAMIC 1800PF	K	
C228			CE04KW1C470M	ELECTRO 47UF	16WV	
C229,230			C91-0757-05	CERAMIC 1000PF	K	
C231			CQ92FM1H103J	MYLAR 0.010UF	J	
C232			CQ92FM1H472J	MYLAR 4700PF	J	
C233			CQ92FM1H153J	MYLAR 0.015UF	J	
C234			CE04KW1C470M	ELECTRO 47UF	16WV	
C235			CF92FV1H223J	MF-C 0.022UF	J	
C236			CQ92FM1H472J	MYLAR 4700PF	J	
C237,238			C91-0085-05	CERAMIC 0.022UF	N	
C239			CE04KW1C220M	ELECTRO 22UF	16WV	
C240,241			CE04KW1H3R3M	ELECTRO 3.3UF	50WV	
C242,243			C91-0745-05	CERAMIC 100PF	K	
C244			CE04KW1C101M	ELECTRO 100UF	16WV	
C245,246			CE04KW1H010M	ELECTRO 1.0UF	50WV	
C247			CE04KW1C221M	ELECTRO 220UF	16WV	
C248,249			CE04KW1H0R1M	ELECTRO 0.1UF	50WV	
C250			CE04KW1H3R3M	ELECTRO 3.3UF	50WV	
C251			CE04KW1C331M	ELECTRO 330UF	16WV	

L : Scandinavia K : USA P : Canada R : Mexico C : China I : Malaysia
Y : PX(Far East, Hawaii) T : England E : Europe G : Germany V : China (Shanghai)
Y : AAFES(Europe) X : Australia Q : Russia H : Korea M : Other Areas Δ indicates safety critical components.

* New Parts

Parts without **Parts No.** are not supplied.
Les articles non mentionnés dans le **Parts No.** ne sont pas fournis.
Teile ohne **Parts No.** werden nicht geliefert.

6

Ref. No	Add-ress	New Parts	Parts No.	Description	Desti-nation	Re-marks
C252			CE04KW1C101M	ELECTRO 100UF	16WV	
C253,254			CE04KW1H3R3M	ELECTRO 3.3UF	50WV	
C255			CE04KW1HR47M	ELECTRO 0.47UF	50WV	
C302			CE04KW1HR22M	ELECTRO 0.22UF	50WV	
C305			CE04KW1H4R7M	ELECTRO 4.7UF	50WV	
C306			CE04KW1H100M	ELECTRO 10UF	50WV	
C307			CE04KW1C101M	ELECTRO 100UF	16WV	
C308			CE04KW1HR22M	ELECTRO 0.22UF	50WV	
C310			CE04KW1HR47M	ELECTRO 0.47UF	50WV	
C311			CE04KW1C220M	ELECTRO 22UF	16WV	
C312			CE04KW1HR47M	ELECTRO 0.47UF	50WV	
C313			CK45FB1H562K	CERAMIC 5600PF	K	
C314			CF92FV1H224J	MF-C 0.22UF	J	
C315			CE04KW1HR47M	ELECTRO 0.47UF	50WV	
C316			C91-0769-05	CERAMIC 0.010UF	K	
C317			C91-0757-05	CERAMIC 1000PF	K	
C318			CK45FB1H683K	CERAMIC 0.068UF	K	
C319,320			CF92FV1H224J	MF-C 0.22UF	J	
C321			C91-0757-05	CERAMIC 1000PF	K	
C322			CK45FB1H683K	CERAMIC 0.068UF	K	
C323			CE04KW1C470M	ELECTRO 47UF	16WV	
C325			CK45FB1H104Z	CERAMIC 0.10UF	Z	
C326			CE04KW1C470M	ELECTRO 47UF	16WV	
C327			C91-0085-05	CERAMIC 0.022UF	N	
C328			C91-0769-05	CERAMIC 0.010UF	K	
C329			CK45FB1H104Z	CERAMIC 0.10UF	Z	
C330			CE04KW1H010M	ELECTRO 1.0UF	50WV	
C332			CE04KW1HR47M	ELECTRO 0.47UF	50WV	
C333			CE04KW1H010M	ELECTRO 1.0UF	50WV	
C334			CK45FB1H562K	CERAMIC 5600PF	K	
C335			CE04KW1C470M	ELECTRO 47UF	16WV	
C336			CE04KW1HR47M	ELECTRO 0.47UF	50WV	
C337,338			CE04KW1H2R2M	ELECTRO 2.2UF	50WV	
C339			CE04KW1C220M	ELECTRO 22UF	16WV	
C340			CE04KW1H2R2M	ELECTRO 2.2UF	50WV	
C341			CK45FB1H473Z	CERAMIC 0.047UF	Z	
C342			CF92FV1H224J	MF-C 0.22UF	J	
C343			CE04KW1H2R2M	ELECTRO 2.2UF	50WV	
C344			CE04KW1H010M	ELECTRO 1.0UF	50WV	
C345			CE04KW1H010M	ELECTRO 1.0UF	50WV	
C346			C91-0085-05	CERAMIC 0.022UF	N	
C357			CE04KW1C221M	ELECTRO 220UF	16WV	
C358			CE04KW1H2R2M	ELECTRO 2.2UF	50WV	
C359,360			C91-0761-05	CERAMIC 2200PF	M	
C401-404			CE04KW1H010M	ELECTRO 1.0UF	50WV	
C405			CE04KW1HR47M	ELECTRO 0.47UF	50WV	
C406-409			CE04KW1H010M	ELECTRO 1.0UF	50WV	
C410			C91-0749-05	CERAMIC 220PF	K	
C411			CE04KW1C101M	ELECTRO 100UF	16WV	
C412			CE04KW1H100M	ELECTRO 10UF	50WV	
C413,414			CE04KW1H2R2M	ELECTRO 2.2UF	50WV	
C415-418			CE04KW1H4R7M	ELECTRO 4.7UF	50WV	
C419			CQ92FM1H183J	MYLAR 0.018UF	J	
C420			CQ92FM1H223J	MYLAR 0.022UF	J	
C421-424			CQ93FMG1H104J	MYLAR 0.10UF	J	

L : Scandinavia K : USA P : Canada R : Mexico C : China I : Malaysia
Y : PX(Far East, Hawaii) T : England E : Europe G : Germany V : China (Shanghai)
Y : AAFES(Europe) X : Australia Q : Russia H : Korea M : Other Areas Δ indicates safety critical components.

PARTS LIST

RXD-V323

* New Parts

Parts without **Parts No.** are not supplied.
Les articles non mentionnés dans le **Parts No.** ne sont pas fournis.
Teile ohne **Parts No.** werden nicht geliefert.

7

Ref. No	Add-ress	New Parts	Parts No.	Description	Desti-nation	Re-marks
C425			CQ92FM1H223J	MYLAR 0.022UF	J	
C426			CQ92FM1H183J	MYLAR 0.018UF	J	
C427,428			CQ92FM1H152J	MYLAR 1500PF	J	
C429			C91-0749-05	CERAMIC 220PF	K	
C430-433			C91-0745-05	CERAMIC 100PF	K	
C434,435			CE04KW1H010M	ELECTRO 1.0UF	50WV	
C436,437			CE04KW1C101M	ELECTRO 100UF	16WV	
C438			CE04KW1H4R7M	ELECTRO 4.7UF	50WV	
C439			C91-0745-05	CERAMIC 100PF	K	
C440			CE04KW1C101M	ELECTRO 100UF	16WV	
C441			CE04KW1H010M	ELECTRO 1.0UF	50WV	
C442			CE04KW1H4R7M	ELECTRO 4.7UF	50WV	
C443			CQ92FM1H223J	MYLAR 0.022UF	J	
C444			CE04KW1C220M	ELECTRO 22UF	16WV	
C450,451			CK45FB1H104Z	CERAMIC 0.10UF	Z	
C452,453			C91-0745-05	CERAMIC 100PF	K	
C454,455			C91-0753-05	CERAMIC 470PF	K	
C456,457			CE04KW1H2R2M	ELECTRO 2.2UF	50WV	
C458,459			CE04KW1C101M	ELECTRO 100UF	16WV	
C460			CE04BP1H010M	NP-ELEC 1.0UF	50WV	
C501,502			CE04KW1H0R1M	ELECTRO 0.1UF	50WV	
C503,504			C91-0757-05	CERAMIC 1000PF	K	
C505,506			CE04KW1H470M	ELECTRO 47UF	50WV	
C507,508			CE04KW1H101M	ELECTRO 100UF	50WV	
C509,510			CE04KW1H100M	ELECTRO 10UF	50WV	
C511,512			CQ93FMG1H104J	MYLAR 0.10UF	J	
C513,514			C91-0721-05	CERAMIC 10PF	J	
C515,516			CQ93FMG1H104J	MYLAR 0.10UF	J	
C517,518			C91-0085-05	CERAMIC 0.022UF	N	
C519			CE04KW1H010M	ELECTRO 1.0UF	50WV	
C520			CE04KW1C101M	ELECTRO 100UF	16WV	
C521,522			C91-0757-05	CERAMIC 1000PF	K	
C525			CK45FB1H104Z	CERAMIC 0.10UF	Z	
C526,527			C91-0757-05	CERAMIC 1000PF	K	
C528			CK45FB1H104Z	CERAMIC 0.10UF	Z	
C529,530			C91-0745-05	CERAMIC 100PF	K	
C601			CK45FB1H104Z	CERAMIC 0.10UF	Z	
C602			CE04KW1C101M	ELECTRO 100UF	16WV	
C603		*	CE04KW0J472M	ELECTRO 4700UF	6.3WV	
C604			C91-0085-05	CERAMIC 0.022UF	N	
C605			CE04KW1A101M	ELECTRO 100UF	10WV	
C606			CE04KW1C471M	ELECTRO 470UF	16WV	
C607			C91-0085-05	CERAMIC 0.022UF	N	
C608			CE04KW1A101M	ELECTRO 100UF	10WV	
C609			CK45FB1H104Z	CERAMIC 0.10UF	Z	
C610,611			C91-0749-05	CERAMIC 220PF	K	
C612,613			CC45FCH1H200J	CERAMIC 20PF	J	
C614			CK45FB1H104Z	CERAMIC 0.10UF	Z	
C615			CE04KW1H2R2M	ELECTRO 2.2UF	50WV	
C616			CE04KW1H010M	ELECTRO 1.0UF	50WV	
C617			CK45FB1H104Z	CERAMIC 0.10UF	Z	
C618			CE04KW1C470M	ELECTRO 47UF	16WV	
C619			CE04KW1H010M	ELECTRO 1.0UF	50WV	
C620,621			C91-0085-05	CERAMIC 0.022UF	N	
C700			CK14F1H473Z	CERAMIC 0.047UF	Z	

L : Scandinavia K : USA P : Canada R : Mexico C : China I : Malaysia
Y : PX(Far East, Hawaii) T : England E : Europe G : Germany V : China (Shanghai)
Y : AAFES(Europe) X : Australia Q : Russia H : Korea M : Other Areas Δ indicates safety critical components.

* New Parts

Parts without **Parts No.** are not supplied.
Les articles non mentionnés dans le **Parts No.** ne sont pas fournis.
Teile ohne **Parts No.** werden nicht geliefert.

8

Ref. No	Add-ress	New Parts	Parts No.	Description	Desti-nation	Re-marks
C701			CE04KW1V332M	ELECTRO 3300UF	35WV	
C702-705			C91-0085-05	CERAMIC 0.022UF	N	
C706,707			CE04KW1H332M	ELECTRO 3300UF	50WV	
C708-711			CK45FB1H103Z	CERAMIC 0.010UF	Z	
C712,713			C91-0085-05	CERAMIC 0.022UF	N	
C714			CE04KW1C101M	ELECTRO 100UF	16WV	
C715			CE04KW1C471M	ELECTRO 470UF	16WV	
C716,717			C91-0085-05	CERAMIC 0.022UF	N	
C718			CE04KW1C221M	ELECTRO 220UF	16WV	
C719			CE04KW1C471M	ELECTRO 470UF	16WV	
C720,721			C91-0085-05	CERAMIC 0.022UF	N	
C722			CE04KW1C101M	ELECTRO 100UF	16WV	
C723			C91-0085-05	CERAMIC 0.022UF	N	
C724			CE04KW1C101M	ELECTRO 100UF	16WV	
C725			CE04KW1J221M	ELECTRO 220UF	63WV	
C726,727			C91-0085-05	CERAMIC 0.022UF	N	
C728			CE04KW1J221M	ELECTRO 220UF	63WV	
C729			CE04KW1H101M	ELECTRO 100UF	50WV	
C730			C91-0085-05	CERAMIC 0.022UF	N	
C731			CE04KW1H101M	ELECTRO 100UF	50WV	
C732			C91-0085-05	CERAMIC 0.022UF	N	
C734,735			C91-0085-05	CERAMIC 0.022UF	N	
C736,737			CE04KW1A101M	ELECTRO 100UF	10WV	
C738			CE04KW1C221M	ELECTRO 220UF	16WV	
C739,740			C91-0085-05	CERAMIC 0.022UF	N	
C741			CE04KW1H010M	ELECTRO 1.0UF	50WV	
C742			CE04KW1C101M	ELECTRO 100UF	16WV	
C801-804			CK45FB1H473Z	CERAMIC 0.047UF	Z	
C805			CE04KW1C470M	ELECTRO 47UF	16WV	
C806			CE04KW1H4R7M	ELECTRO 4.7UF	50WV	
C807			CE04KW1C470M	ELECTRO 47UF	16WV	
C808			CK45FB1H473Z	CERAMIC 0.047UF	Z	
C809			C91-0745-05	CERAMIC 100PF	K	
C810			CK45FB1H104Z	CERAMIC 0.10UF	Z	
C811-814			C91-0749-05	CERAMIC 220PF	K	
C815			C91-0745-05	CERAMIC 100PF	K	
C820			C90-3219-05	ELECTRO 33UF	10WV	
TC73			C05-0239-08	TRIMMER CAP.	5010300045	
TC101			C05-0231-08	TRIMMER CAP.	5010100045	
CN01		*	E40-8525-08	FFC 15P, TOP BASE, 4491500311		
CN02			E35-2340-08	6P CON, ASSY C48P061611		
CN05			E40-8413-08	PH 7P, SIDE BASE, 4490701005		
CN08			E40-8415-08	FFC 5P, SIDE BASE, 4490500265		
CN10			E40-8370-08	FFC 21P, TOP BASE, 4492100263		
CN19			E40-8111-08	2P PIN HEADER, 4494000267		
CN101			E40-8336-08	10P FIW, TOP BASE, 4491000270		
CN201			E40-3261-05	PH 3P 4490301004		
CN202,203			E35-2442-08	7P CON ASSY C488071838		
CN204			E35-2435-08	FFC 16P, TOP BASE, 4491600263		
CN403			E40-9861-08	8P FTW TOP BASE, 4490800270		
CN601			E40-8453-08	10P HEAD 4491000306		
CN601			E40-8454-08	10P BASE 4491000307		
CN602			E40-8455-08	11P HEAD 4491100306		
CN602			E40-8456-08	11P BASE 4491100307		

L : Scandinavia K : USA P : Canada R : Mexico C : China I : Malaysia
Y : PX(Far East, Hawaii) T : England E : Europe G : Germany V : China (Shanghai)
Y : AAFES(Europe) X : Australia Q : Russia H : Korea M : Other Areas Δ indicates safety critical components.

PARTS LIST

RXD-V323

* New Parts
 Parts without **Parts No.** are not supplied.
 Les articles non mentionnés dans le **Parts No.** ne sont pas fournis.
 Teile ohne **Parts No.** werden nicht geliefert.



Ref. No	Add-ress	New Parts	Parts No.	Description	Desti-nation	Re-marks
CN603			E40-8370-08	FFC 21P, TOP BASE, 4492100263		
CN803			E40-8334-08	3P FTW TOP BASE, 4490300270		
JK101			E70-0070-08	4P ANT TERMINAL, 4560004086		
JK301			E11-0387-08	MIC JACK 4500500460		
JK401			E63-1076-08	4P RCA JACK 4500800421		
JK402			E63-1075-08	1P RCA JACK 4500800432		
JK501			E70-0108-08	4P SPEAKER TER, 4560004076		
JK502		*	E11-0943-08	H/P JACK 4500700419		
TP1_2			E40-8111-08	40P PIN HEADER 4494000297		
Δ F701,703			F05-3121-05	FUSE T3.15AL250V, 5267315L62		
Δ F702			F05-1623-05	FUSE T1.6AL250V, 5267160L62		
F701,702			J13-0089-08	FUSE HOLDER 4692000034		
F703			J13-0089-08	FUSE HOLDER		
CF101			L72-0586-08	CERAMIC FILTER 4160220044		
CF102			L72-0591-08	CERAMIC FILTER 4160200003		
CF103			L72-0587-08	CERAMIC FILTER 4160500089		
CF104			L78-0706-08	CERAMIC FILTER 4160200293		
L03			L39-1376-08	P COIL 4325010093		
L05		*	L39-1386-08	CHOKO COIL 4327471150		
L06			L39-1383-08	MOTOR CHOKE 4320101156		
L07_09		*	L39-1385-08	FERRITE CORE 7089200001		
L12_13		*	L39-1385-08	FERRITE CORE 7089200001		
L16_17		*	L39-1385-08	FERRITE CORE 7089200001		
L24			L39-1332-08	P COIL 4325022092		
L26_27		*	L39-1385-08	FERRITE CORE 7089200001		
L28_29			L39-1332-08	P COIL 4325022092		
L30		*	L39-1385-08	FERRITE CORE 7089200001		
L101-103			L39-1334-08	P COIL 4325022093		
L106			L39-1344-08	P COIL 4625047093		
L107			L39-1332-08	P COIL 4325022092		
L201			L32-1007-08	BIAS OSC COIL 4330802060		
L301			L39-1377-08	P COIL 4325010193		
L501,502			L39-1341-08	SPEAKER COIL 4299500026		
L601		*	L39-1386-08	CHOKO COIL 4327471150		
L801,802			L39-1375-08	MOTOR CHOKE 4328247186		
T102			L30-0922-08	AM IFT 4340101240		
T103			L31-0618-08	AM ANT COIL 4300103280		
T104			L32-0581-08	MW OSC COIL 4330102020		
X101			L77-2243-08	CRYSTAL(7.2MHZ) 410090720M		
X601			L77-2244-08	CRYSTAL(6.00MHZ)410090600M		
XTL01			L77-2166-08	CRYSTAL(16.9344MHZ)410091693M		
XTL02			L77-2244-08	CRYSTAL(6.00MHZ)410090600M		
XTL03		*	L77-2272-08	CRYSTAL(54MHZ) 4100900540		
R102			RS14DB2H101J	FL-PROOF RS 100 J 1/2W		
R125			RS14DB2H101J	FL-PROOF RS 100 J 1/2W		
R220			RS14AB3A221J	FL-PROOF RS 220 J 1W		
R411			RS14AB3A331J	FL-PROOF RS 330 J 1W		
Δ R506,507			RS14DB2H101J	FL-PROOF RS 100 J 1/2W		
R510,511			R92-1923-08	CEMENT R 0.22 J 2W		
R516,517			RS14GB2H4R7J	FL-PROOF RS 4.7 J 1/2W		
R525,526			RS14AB3A331J	FL-PROOF RS 330 J 1W		
R529			RS14AB3A100J	FL-PROOF RS 10 J 1W		
R530,531			RS14GB2H4R7J	FL-PROOF RS 4.7 J 1/2W		

L : Scandinavia K : USA P : Canada R : Mexico C : China I : Malaysia
 Y : PX(Far East, Hawaii) T : England E : Europe G : Germany V : China (Shanghai)
 Y : AAFES(Europe) X : Australia Q : Russia H : Korea M : Other Areas Δ indicates safety critical components.

* New Parts
 Parts without **Parts No.** are not supplied.
 Les articles non mentionnés dans le **Parts No.** ne sont pas fournis.
 Teile ohne **Parts No.** werden nicht geliefert.



Ref. No	Add-ress	New Parts	Parts No.	Description	Desti-nation	Re-marks
Δ R701			RS14AB3A1R0J	FL-PROOF RS 1 J 1W		
R703			RS14AB3A221J	FL-PROOF RS 220 J 1W		
R704			RS14GB2H471J	FL-PROOF RS 470 J 1/2W		
R705,706			RS14DB3A101J	FL-PROOF RS 100 J 1W		
R707			RS14KB3A102J	FL-PROOF RS 1.0K J 1W		
R710			RS14KB3A100J	FL-PROOF RS 10 J 1W		
R712			RS14GB3A332J	FL-PROOF RS 3.3K J 1W		
R713			RS14GB3D152J	FL-PROOF RS 1.5K J 2W		
SFR101			R32-0087-08	TRIMMING POT 5226223177		
SFR201			R32-0088-08	TRIMMING POT 5226202177		
VR301		*	R31-0104-08	VR 5021114327		
VR302		*	R31-0105-08	VR 5021114328		
VR801			T99-0616-08	VR ENCODER 5020100311		
VR802			T99-0626-08	VR ENCODER 5020100312		
Δ RL501			S76-0048-08	RELAY 4390000062		
S701			S62-0083-08	SLIDE SWITCH 4410206199		
S801-815			S70-0076-08	TACT SWITCH 440A0000160		
S816-822			S70-0076-08	TACT SWITCH 44A0000160		
D09			1N4148	DIODE 4121141480		
D10			1SS133	DIODE		
D12			1SS133	DIODE		
D13			1N4148	DIODE 4121141480		
D14			1SS133	DIODE		
D17			1SS133	DIODE		
D18			1N4148	DIODE 4121141480		
D101,102			1SS133	DIODE		
D103			MTZJ5.6B	ZENER DIODE		
D104			1SS133	DIODE		
D105			SVC348S-TL	DIODE		
D107,108			1SS133	DIODE		
D201-206			1SS133	DIODE		
D301			1N4148	DIODE		
D302			1SS133	DIODE		
D401,402			1SS133	DIODE		
D403,404			1SS133	DIODE		
D405			1SS133	DIODE		
D501,502			1SS133	DIODE		
D503			MTZJ5.1B	ZENER DIODE		
D504			1SS133	DIODE		
D601,602			1N4002L	DIODE		
D603-606			1SS133	DIODE		
Δ D701,702			GBU4D	DIODE 41300GBU4D		
D703			MTZJ13B	ZENER DIODE		
D704			MTZJ8.2B	ZENER DIODE		
D705			MTZJ12B	ZENER DIODE		
Δ D706,707			1N4002L	DIODE		
D708			MTZJ33B	ZENER DIODE		
D710			MTZJ6.2B	ZENER DIODE		
D711			1N4002L	DIODE		
D712			1SS133	DIODE		
D713			MTZJ12B	ZENER DIODE		
D714-716			1SS133	DIODE		
D801			MTZJ5.6B	ZENER DIODE		
FLD801			BJ665GK	FLD DISPLAY 4110540262		

L : Scandinavia K : USA P : Canada R : Mexico C : China I : Malaysia
 Y : PX(Far East, Hawaii) T : England E : Europe G : Germany V : China (Shanghai)
 Y : AAFES(Europe) X : Australia Q : Russia H : Korea M : Other Areas Δ indicates safety critical components.

PARTS LIST

RXD-V323

* New Parts
 Parts without **Parts No.** are not supplied.
 Les articles non mentionnés dans le **Parts No.** ne sont pas fournis.
 Teile ohne **Parts No.** werden nicht geliefert.

11

* New Parts
 Parts without **Parts No.** are not supplied.
 Les articles non mentionnés dans le **Parts No.** ne sont pas fournis.
 Teile ohne **Parts No.** werden nicht geliefert.

12

Ref. No	Add-ress	New Parts	Parts No.	Description	Desti-nation	Re-marks
IC01			LA9241	IC 4152092410		
IC02			LC78630E	IC(SERVO,DSP (CD-ROM))30E		
IC03		*	LC867232A-5L82	IC 415286240Z		
IC04			BA5936S	IC(BTL DRIVER)		
IC05			NJM4558L	IC(OP AMP X2)		
IC06		*	BA033T/FP	IC 4159033TFP		
IC07		*	LC74772V-SS0P24	IC 415274772V		
IC08		*	LC74202E	IC 415274202E		
IC09			TC7WH04FU	IC 41537WH04F		
IC10		*	LC32V4265T	IC 4152324265		
IC102			LA1833L	IC		
IC103			LC72131D	IC		
IC201			TA8189N	IC 415308189N		
IC301			TA2011S	IC		
IC302			M65850P	IC		
IC303			BA3837	IC		
IC304			NJM78L05A	IC(VOLTAGE REGULATOR/ +5V)		
IC401			TDA7439	IC 415D074390		
IC402,403			NJM4558L	IC(OP AMP X2)		
IC501			STK407-040	IC 4152040740		
IC601		*	LC867248A-5L83	IC 415286240Y		
IC801			M66004SPA	IC 415966004P		
Q01 ,02			2SA952	TRANSISTOR 410500952L		
Q03 ,04			2SC945	TRANSISTOR 410520945P		
Q05			2SA952	TRANSISTOR 410500952L		
Q06			2SD882	TRANSISTOR		
Q07			2SA952	TRANSISTOR 410500952L		
Q10 ,11			2SC945	TRANSISTOR 410520945P		
Q12			DTA114TS	TRANSISTOR 410910114T		
Q15			DTA114TS	TRANSISTOR 410910114T		
Q18 ,19			2SA1175	TRANSISTOR 410501175E		
Q20			2SC2785	TRANSISTOR 410522785E		
Q21 ,22			2SA1175	TRANSISTOR 410501175E		
Q101			2SC1675(L)	TRANSISTOR 410521675L		
Q102			2SJ460	FET 4107004600		
Q103,104			2SK2541	FET 4106502541		
Q105			2SK544F-T	FET 410650544F		
Q201,202			2SC945	TRANSISTOR		
Q203-206			2SC2001	TRANSISTOR		
Q207			2SA733	TRANSISTOR		
Q210			2SA733	TRANSISTOR		
Q211			2SC2001	TRANSISTOR		
Q212			2SA733	TRANSISTOR		
Q213-218			2SC945	TRANSISTOR		
Q219			2SA934	TRANSISTOR		
Q220			2SC945	TRANSISTOR		
Q221			2SA934	TRANSISTOR		
Q222			2SC945	TRANSISTOR		
Q223			2SA934	TRANSISTOR		
Q224-226			2SC945	TRANSISTOR		
Q301,302			2SC945	TRANSISTOR		
Q303,304			DTC114TS	TRANSISTOR		
Q401,402			2SC945	TRANSISTOR		
Q403,404			2SK2541	FET		
Q405			2SJ460	FET		

L : Scandinavia K : USA P : Canada R : Mexico C : China I : Malaysia
 Y : PX(Far East, Hawaii) T : England E : Europe G : Germany V : China (Shanghai)
 Y : AAFES(Europe) X : Australia Q : Russia H : Korea M : Other Areas Δ indicates safety critical components.

Ref. No	Add-ress	New Parts	Parts No.	Description	Desti-nation	Re-marks
Q406			2SC945	TRANSISTOR		
Q407,408			2SC2878A	TRANSISTOR		
Q409			2SJ460	FET		
Q410			2SC945	TRANSISTOR		
Q501,502			2SC1841	TRANSISTOR		
Q503			2SA988	TRANSISTOR		
Q504			2SC945	TRANSISTOR		
Q505,506			2SC2878A	TRANSISTOR		
Q601,602			2SC945	TRANSISTOR		
Q603			2SA934	TRANSISTOR		
Q604,605			DTA114ES	TRANSISTOR		
Q701			2SD313E	TRANSISTOR 410030313E		
Q702			2SC945	TRANSISTOR		
Q703,704			2SD313E	TRANSISTOR 410030313E		
Q705			2SA965Y	TRANSISTOR		
Q706			2SC2001	TRANSISTOR		
Q707			DTC144ES	TRANSISTOR		
FE101			W02-2709-08	FRONT END 716J2U573A		
RM801			W02-2710-08	REMOTE RECEIVER, 714SPS4472		
MOTOR PCB						
C01			CE04KW1C4R7M	ELECTRO 4.7UF 16VV		
C82A			C91-1525-08	CERAMIC 0.1UF Z		
CD MECHANISM						
1	2A		J99-0810-08	CHANGER BASE		
2	1A		G16-0953-08	TRAY SHEET(BLK)		
3	2A		N19-1489-08	E-RING (2.5Q)		
4	2A		N19-1485-08	CHANGE GEAR WASHER		
5	2A	*	G01-4181-08	CHANGE GEAR SPRING 2A13B49100		
6	2A		D13-1925-08	CHANGE GEAR		
7	2A		N19-1486-08	POLY WASHER (Q1.4XQ4.1X0.3T)		
8	2A		J19-5990-08	CHANGE PLATE ASSEMBLY		
10	2A		D13-1926-08	RELAY GEAR B		
11	2A		N19-1487-08	CHANGE PLATE WASHER		
13	2A		D15-0415-08	GEAR PULLEY		
14	2A		D16-0727-08	LOADING BELT		
15	2A		D13-1927-08	RELAY GEAR A		
17	2A	*	D13-1974-08	TR LOCK GEAR 2A14C49100		
18	1A		D13-1929-08	RELAY GEAR C		
19	1B,1C		G16-0954-08	CUSHION (12X8X4.2T) 2058049100		
20	1A		D13-1930-08	TR GEAR		
21	1A		F07-1671-08	BLIND SHEET		
22	1A		J30-0493-08	SWITCH FIBER		
24	1A		J99-0812-08	TURNTABLE (TRAY)		
26	2A		G13-0596-08	SWITCH LEVER CUSHION		
27	1B		D10-3871-08	SENSOR SWITCH LEVER		
30	1B		G01-4126-08	SENSOR SWITCH LEVER SPRING		
32	1B		J90-0868-08	TURNTABLE FIXING PLATE		
38	1B		D14-0806-08	ROLLER		
42	2C		G01-4127-08	MECHA BASE SPRING (A)		
43	2C	*	J19-6049-08	MECHA BASE KSM 2A01C49100		
45	1C		G01-4128-08	MECHA BASE SPRING		
46	1C		D39-0340-08	DUMPER (RED)		
47	1C	*	D40-1665-08	CD MECHANISM (DA11) C486040443		

L : Scandinavia K : USA P : Canada R : Mexico C : China I : Malaysia
 Y : PX(Far East, Hawaii) T : England E : Europe G : Germany V : China (Shanghai)
 Y : AAFES(Europe) X : Australia Q : Russia H : Korea M : Other Areas Δ indicates safety critical components.

* New Parts
 Parts without **Parts No.** are not supplied.
 Les articles non mentionnés dans le **Parts No.** ne sont pas fournis.
 Teile ohne **Parts No.** werden nicht geliefert.

13

Ref. No	Add-ress	New Parts	Parts No.	Description	Desti-nation	Re-marks
49	1C		D39-0341-08	DUMPER (GREEN)		
50	1B		D15-0416-08	GEAR PULLEY (B)		
51	1B		D16-0728-08	LOADING GEAR BELT		
52	1B		N19-1488-08	POLY WASHER		
54	1B		D13-1931-08	SLIDE GEAR		
56	2B		J11-0844-08	MAGNET HOLDER 2A38A49100		
57	1B		G01-4129-08	CAM BRAKE SPRING		
58	1B		D10-3872-08	SWITCH LEVER		
60	1B		D13-1932-08	UD REDUCE GEAR		
61	1B		T99-0620-08	MAGNET		
62	1B		D12-0160-08	UD CAM		
66	1A	*	A01-3743-08	TURNTABLE PROTECTOR 2M994S0060		
AG			N09-3345-08	SCREW TAPTITE CUP2618 (2.6X16)		
AK			N09-5102-08	RELAY GEAR (B) SCREW		
AL			N09-5101-08	SCREW TAPTITE CUP2010 (2X10)		
S01 ,S02	1B		S64-0028-05	LEVER SWITCH		
S03 ,S04	1A		S64-0043-08	SWITCH MSS-813		
LM	2B		T42-0944-08	MOTOR PULLEY ASSY		
RTM	2B		T42-0945-08	MOTOR PULLEY ASSY		
CASSETTE MECHANISM (D40-1653-08)						
441	2F		D16-0735-08	BELT (B)MECHA SMALL		
442	2F		D16-0736-08	BELT (A)MECHA SMALL		
443	2F		D16-0737-08	BELT (B)MECHA LARGE		
444	2F		D16-0738-08	BELT (A)MECHA LARGE		
SPEAKER (LS-N323)						
-			T03-0505-08	TWEETER UNIT		
-			T10-1006-08	WOOFER UNIT		
-		*	T19-0211-08	SPEAKER BOX AASY 008707994V		

PARTS LIST

RXD-V323

L : Scandinavia K : USA P : Canada R : Mexico C : China I : Malaysia
 Y : PX(Far East, Hawaii) T : England E : Europe G : Germany V : China (Shanghai)
 Y : AAFES(Europe) X : Australia Q : Russia H : Korea M : Other Areas Δ indicates safety critical components.

RXD-V323

SPECIFICATIONS

[Amplifier section]

Effective output power during STEREO operation	
1 kHz, 10 % T.H.D., 6 Ω	43 W + 43 W
Rated output power during STEREO operation	
1 kHz, 1.0 % T.H.D., 6 Ω	30 W + 30 W
Input sensitivity / impedance	
AUX	300 mV / 40 kΩ
MIC	2.5 mV / 2.2 kΩ
Output level / impedance	
AUX	200 mV / 2.2 kΩ

[Tuner section]

FM tuner section	
Tuning frequency range	87.5 MHz ~ 108 MHz
AM Tuner section	
Tuning frequency range	
9 kHz step	531 kHz ~ 1,602 kHz
10 kHz step	530 kHz ~ 1,610 kHz

[Cassette deck section]

Track	4-track, 2-channel stereo
Recording system	AC bias system (Frequency: 105 kHz)
Heads	
A deck Playback head	1
B deck Playback / recording head	1
Erasing head	1
Motor	1

[CD/VIDEO CD player section]

Laser	Semiconductor laser
Wow & Flutter	Less than unmeasurable Limit
Video output format	NTSC/PAL
Composit video output level	1 Vp-p (75 Ω negativ sync)
Compression format	MPEG1

[General]

Power consumption	150 W
Dimensions	W: 280 mm (11") H: 330 mm (13") D: 405 mm (15-15/16")
Weight (net)	8.3 kg (18.3 lb)

Speakers (LS-N323)

Enclosure	Bass-reflex type
Speaker configuration	
Woofers	130 mm, cone type
Tweeter	50 mm, cone type
Impedance	6 Ω
Maximum input level	43 W
Dimensions	W: 220 mm (8-11/16") H: 330 mm (13") D: 245 mm (9-5/8")
Weight (net)	3.2 kg (7.1 lb) (1 piece)



1. KENWOOD follows a policy of continuous advancements in development. For this reason specifications may be changed without notice.
2. Sufficient performance may not be possible at very low temperatures (0°C or less).

Note:

Component and circuit are subject to modification to insure best operation under differing local conditions. This manual is based on Europe (E) standard, and provides information on regional circuit modification through use of alternate schematic diagrams, and information on regional component variations through use of parts list.

KENWOOD CORPORATION

14-6, Dogenzaka 1-chome, Shibuya-ku, Tokyo, 150-8501 Japan

KENWOOD SERVICE CORPORATION

P.O BOX 22745, 2201 East Dominguez St., Long Beach, CA 90801-5745, U.S.A.

KENWOOD ELECTRONICS CANADA INC.

6070 Kestrel Road, Mississauga, Ontario, Canada L5T 1S8

KENWOOD ELECTRONICS LATIN AMERICA S.A.

P.O BOX 55-2791, Piso 6 plaza Chase, Cl. 47 y Aquilino de la Guardia Panama, Republic de Panama

KENWOOD ELECTRONICS BRASIL LTDA.

Av. Moema, 170-17, Andar-Cobertura "B", Ed. Maximum Service Center, 04077-020 Moema, São Paulo-SP-Brasil

KENWOOD ELECTRONICS U.K. LIMITED

KENWOOD House, Dwight Road, Watford, Herts., WD1 8EB., United Kingdom

KENWOOD ELECTRONICS BELGIUM N.V.

Meachelsesteenweg 418, B-1930 Zaventem, Belgium

KENWOOD ELECTRONICS DEUTSCHLAND GMBH

Rembrücker Str. 15, 63150 Heusenstamm, Germany

KENWOOD ELECTRONICS FRANCE S.A.

13 Boulevard Ney, 75018 Paris, France

KENWOOD ELECTRONICS ITALIA S.p.A.

Via G. Sirtori, 7/9 20129, Milano, Italy

KENWOOD IBÉRICA S.A.

Bolivia, 239-08020 Barcelona, Spain

KENWOOD ELECTRONICS AUSTRALIA PTY. LTD.

(A.C.N. 001499 074)
P.O Box 504, 8 Figtree Drive, Australia Centre, Homebush, N.S.W. 2140, Australia

KENWOOD & LEE ELECTRONICS, LTD.

Unit 3712-3724, Level 37, Tower 1, Metroplaza, 223 Hing Fong Road, Kwai Fong N.T., Hong Kong

KENWOOD ELECTRONICS GULF FZE

P.O.Box 61318, Jebel Ali, Dubai, U.A.E.

KENWOOD ELECTRONICS SINGAPORE PTE LTD.

No. 1 Genting Lane #02-02, KENWOOD Building, Singapore, 349544

KENWOOD ELECTRONICS (MALAYSIA) SDN BHD.

#4.01 Level 4, Wisma Academy Lot 4A, Jalan 19/1 46300 Petaling Jaya Selangor Darul Ehsan Malaysia

KENWOOD ELECTRONICS (THAILAND) CO., LTD.

2019 New Pechburi Road, Bangkapi, Huaykwang, Bangkok, 10320 Thailand