



SW-505D-S/505D-W

CONTENTS / ACCESSORIES

Contents

SPECIFICATIONS	Front cover	SCHEMATIC DIAGRAM	5
CONTENTS / ACCESSORIES	2	EXPLODED VIEW	8
ADJUSTMENT	2	PARTS LIST	9
PC BOARD	3		

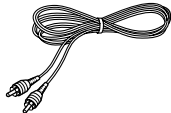
Accessories

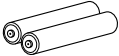
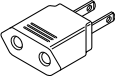
<p>Pin-plug cord (1) (E30-5860-08)</p> 	<p>Remote control unit (1) (A70-0409-08)</p> 	<p>Batteries (R03/ AAA)</p> 	<p>AC plug adaptor (1) (E03-0115-05)</p>  <p>* Use to adapt the plug on the power cord to the shape of the wall outlet. (Accessory only for regions where use is necessary)</p>
--	--	---	--

ADJUSTMENT

No.	ITEM	INPUT SETTINGS	OUTPUT SETTINGS	AMPLIFIER SETTINGS	ALIGNMENT POINT	ALIGN FOR	FIG.
1	OFF SET	—	Connect a DC voltmeter to speaker terminal.	VOLUME: 0	VR201	0 mV	

PC BOARD (Component side view)

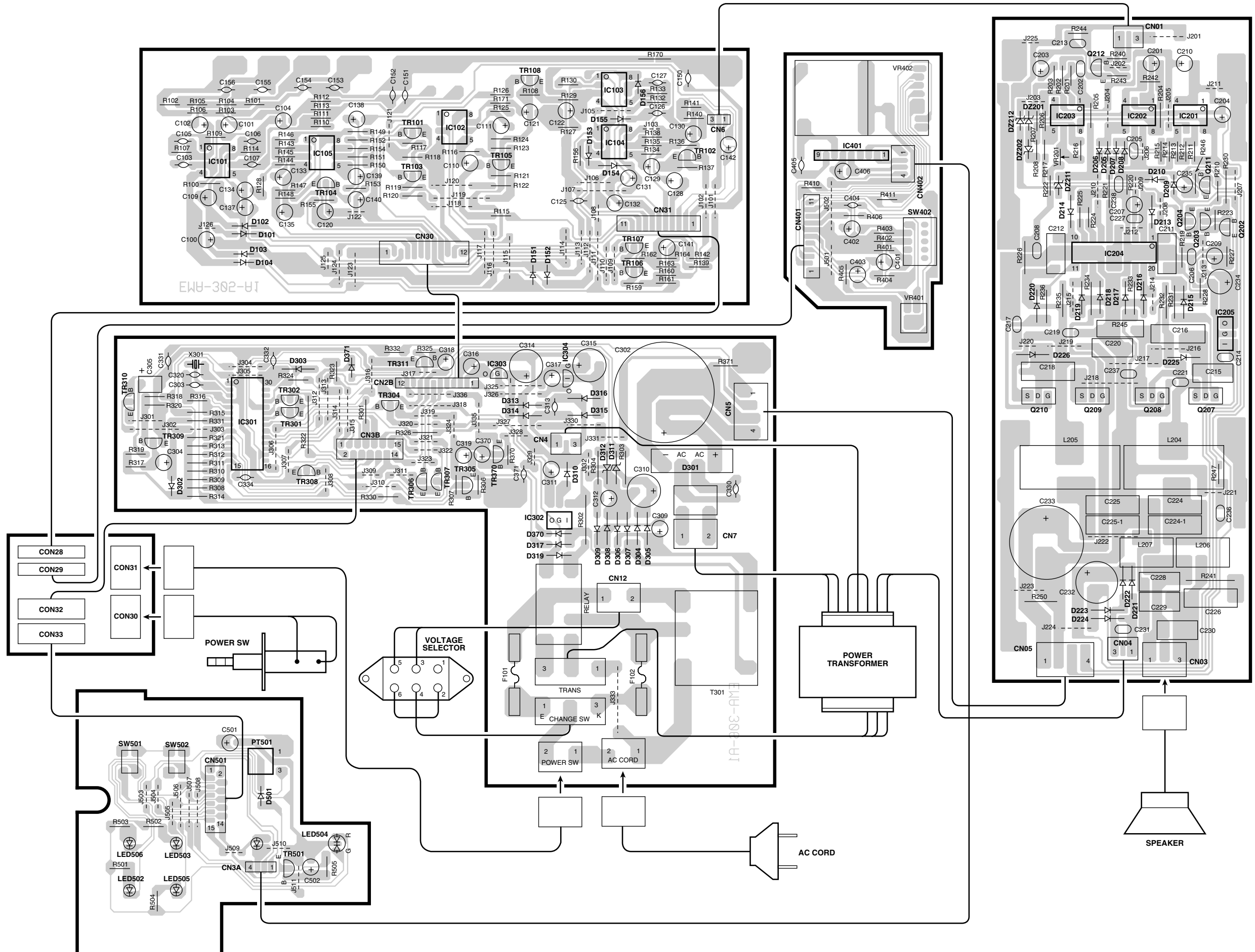

Refer to the schematic diagram for the value of resistors and capacitors.

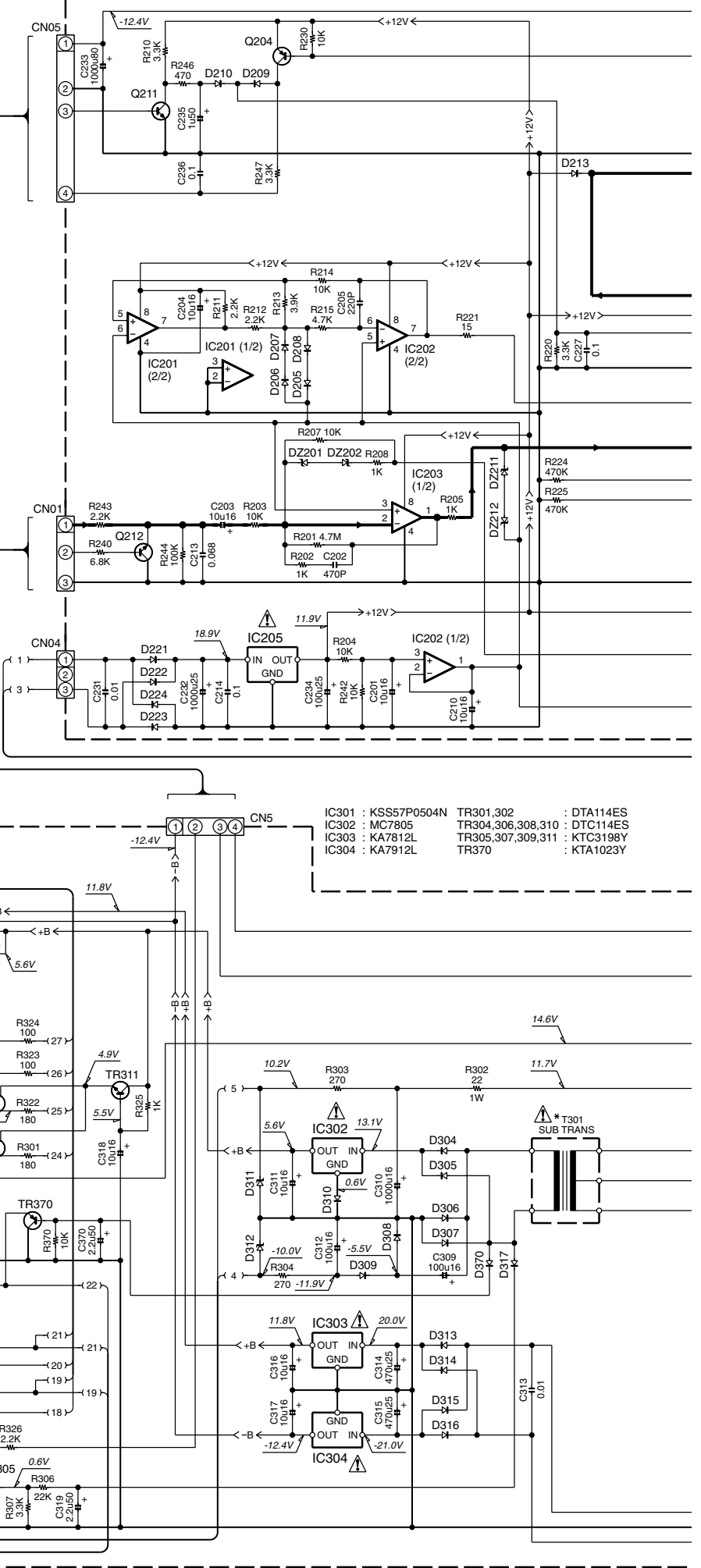
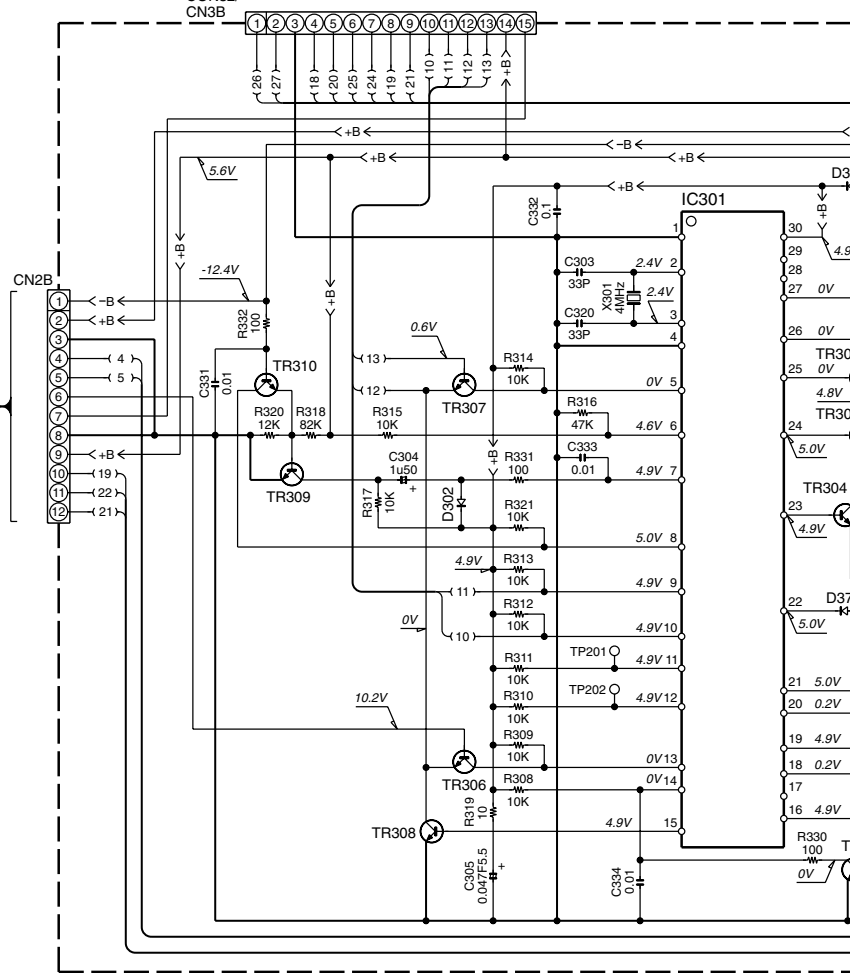
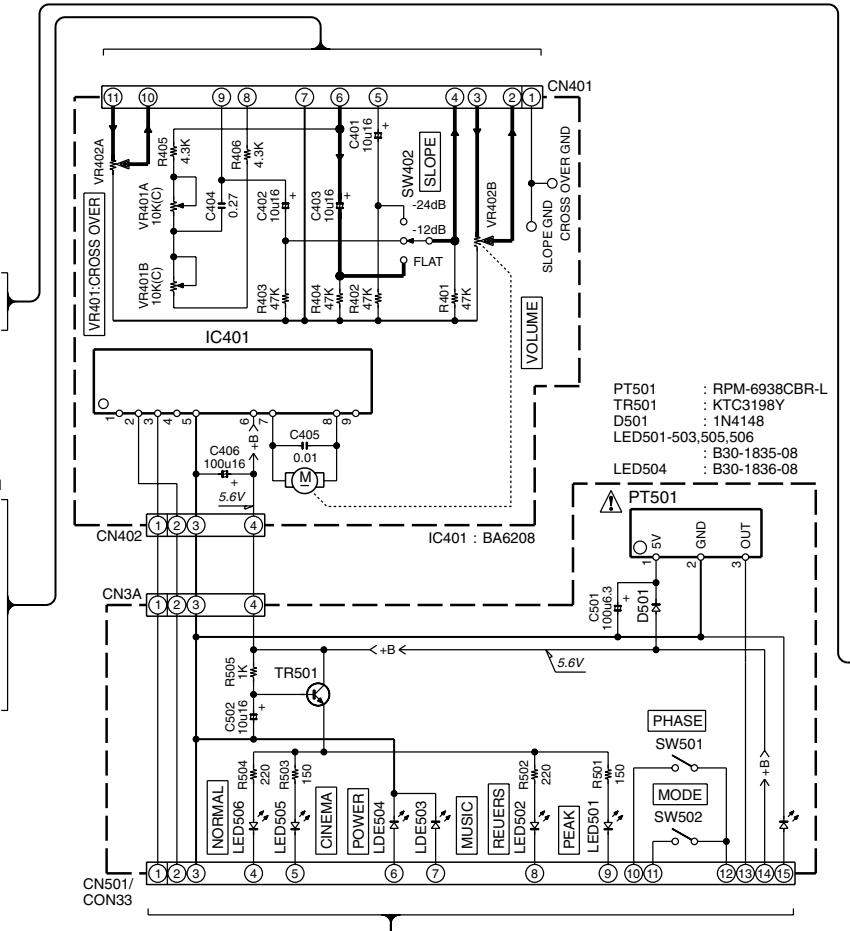
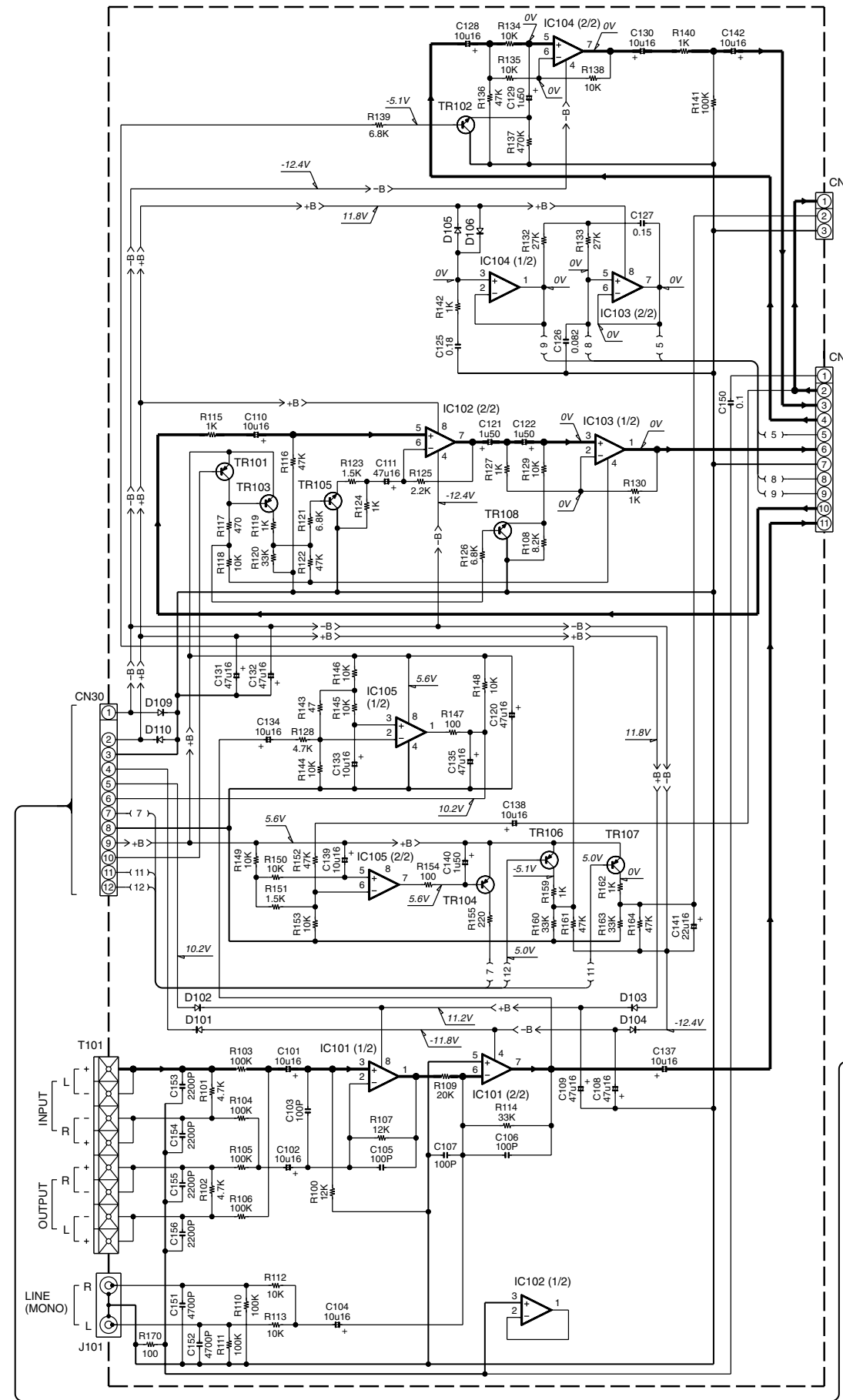

— SIGNAL LINE
 — GND LINE
 — +B LINE
 — -B LINE

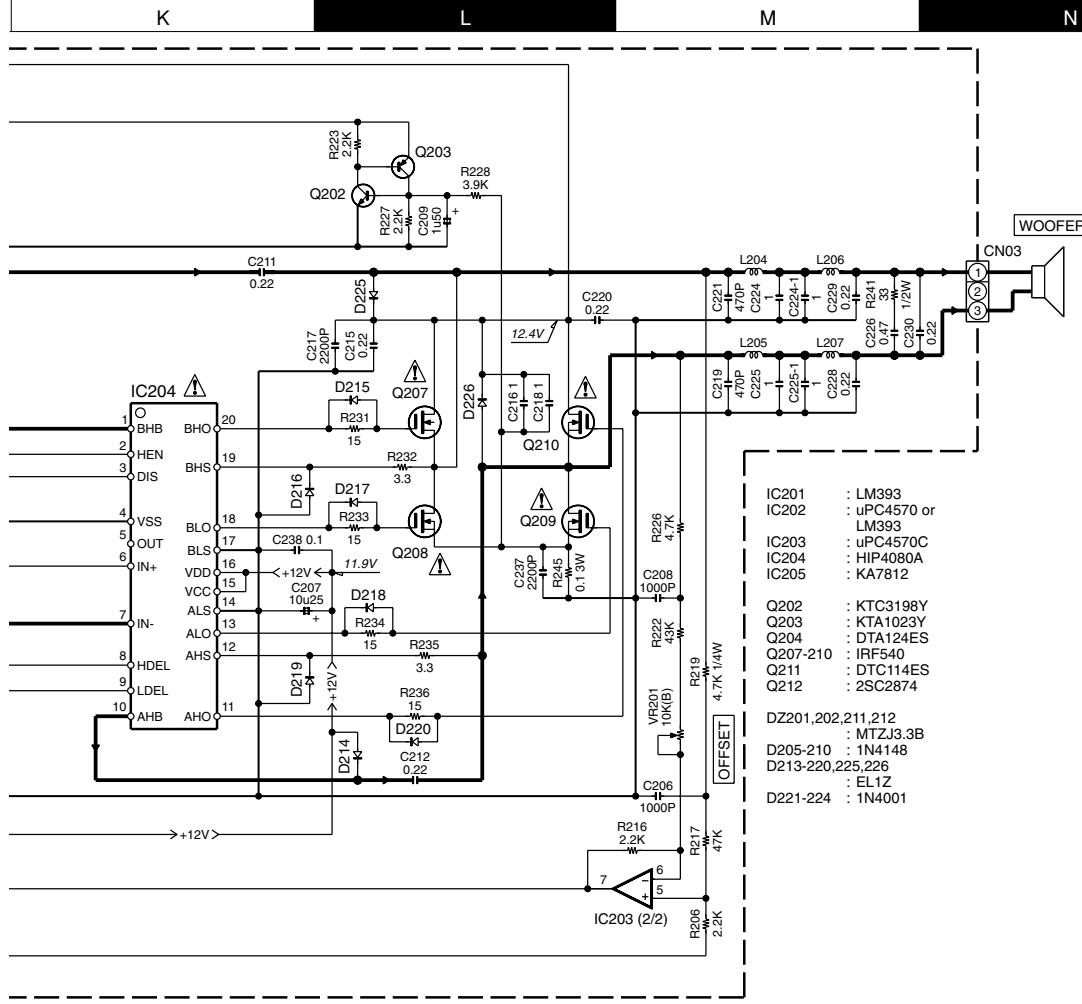

DTA114ES
 DTA124ES
 DTC114ES

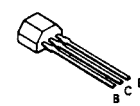

UPC4570C

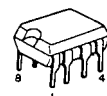

BA4558N

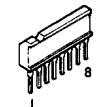

CAUTION: For continued safety, replace safety critical components only with manufacturer's recommended parts (refer to parts list). Δ indicates safety critical components. For continued protection against risk of fire, replace only with same type and rating fuse(s). To reduce the risk of electric shock, leakage-current or resistance measurements shall be carried out (exposed parts are acceptably insulated from the supply circuit) before the appliance is returned to the customer.

The DC voltage is an actual reading measured with a high impedance type voltmeter with no signal input. The measurement value may vary depending on the measuring instruments used or on the product.

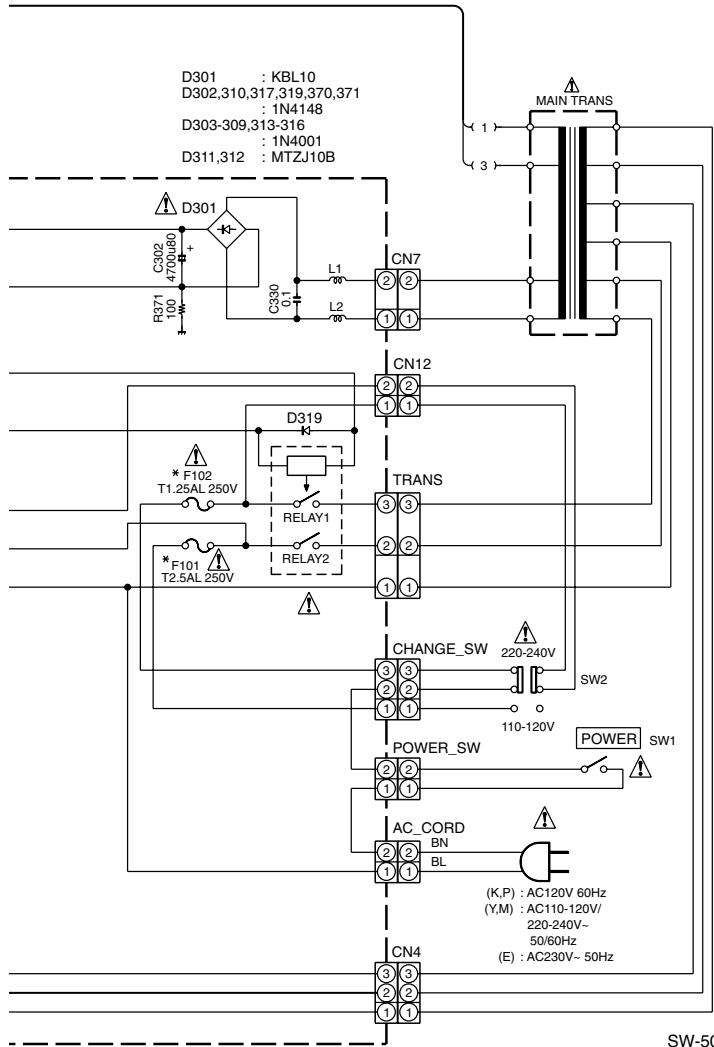

DESTINATION COUNTRY	ABB.	F101	F102	T301	SW2
U.S.A.	K		NO		NO
CANADA	P		NO		NO
PX	Y	YES		L07-3036-08	YES
GENERAL MARKET	M		YES		YES
EUROPE	E	NO		L07-3037-08	NO

SW-505D-S/505D-W

SW-505D-S/505D-W

EXPLODED VIEW (UNIT)

A

B

C

- A ϕ 3x8 (BLK) :N50-3008-45
- B ϕ 3x10 (BLK) :N50-3010-45
- C ϕ 4x18 (BLK) :N50-4018-45
- D ϕ 4x14 (BLK) :N50-4014-45
- E M4x18 (BLK) :N50-4018-45
- F ϕ 4x12 (BLK) :N30-4012-45
- G ϕ 3x6 (BLK) :N50-3006-45
- H ϕ 2.6x8 (BLK) :N50-2608-45
- J M4 :N11-0040-46
- K M3x10 (BLK) :N30-3010-45
- L M3 :N11-0030-45
- M 3x12(BLK) :N50-3012-45

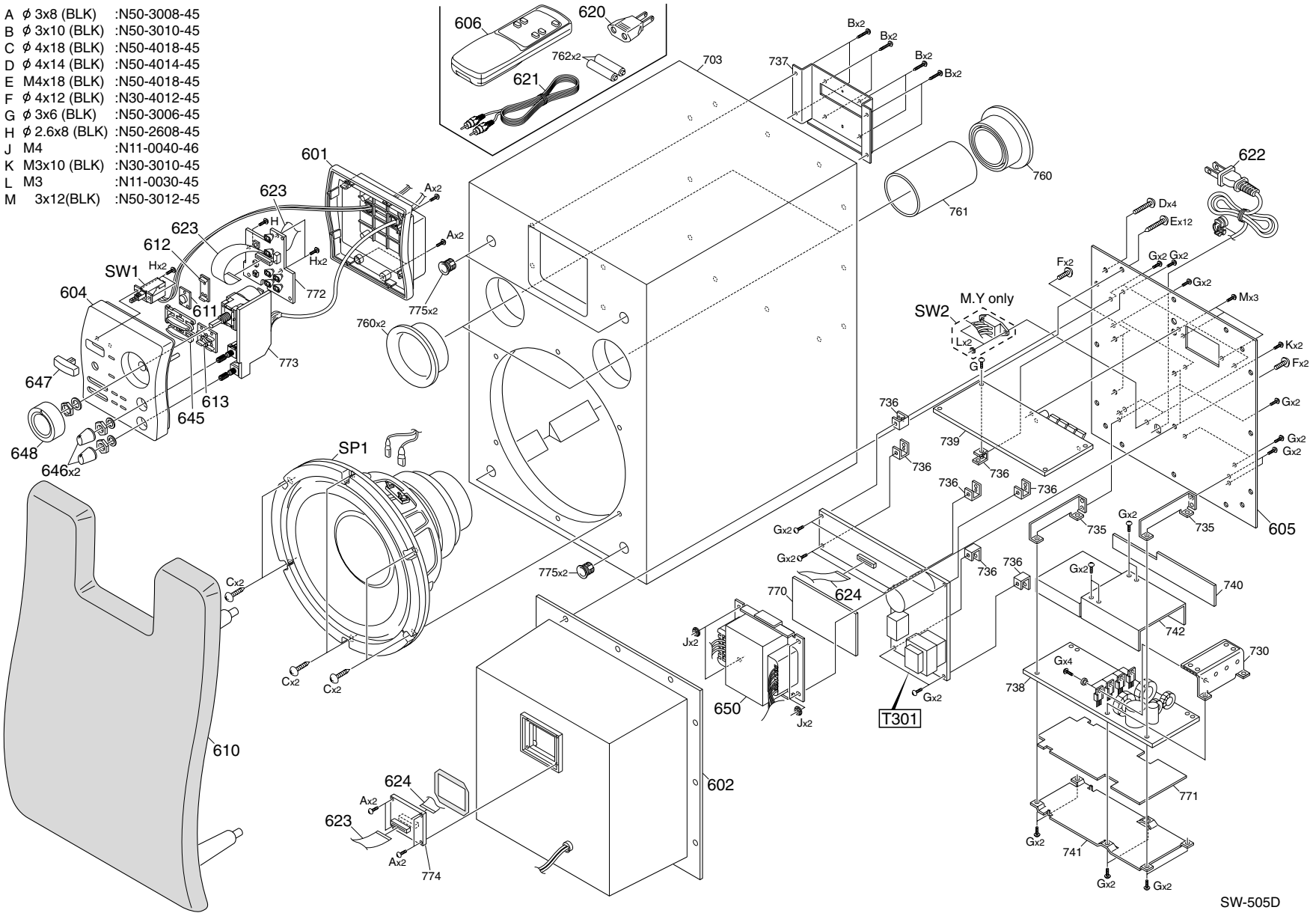

SW-505D

Parts with exploded numbers larger than 700 are not supplied.

* New Parts
Parts without **Parts No.** are not supplied.
Les articles non mentionnés dans le **Parts No.** ne sont pas fournis.
Teile ohne **Parts No.** werden nicht geliefert.

①

Ref. No	Add-ress	New Parts	Parts No.	Description	Desti-nation	Re-marks
SW-505D W:WHITE/B:BLACK						
601	1A	*	A02-2538-08	CONTROL BOX	BDCC-0006-01	B
601	1A	*	A02-2541-08	CONTROL BOX	BDCC-0007-01	W
602	2B	*	A02-2539-08	AMP BOX	BDCC-0003-01	
604	1A	*	A21-3341-08	CONTROL PANEL	BDCC-0004-01	B
604	1A	*	A21-3343-08	CONTROL PANEL	BDCC-0005-01	W
605	2C	*	A23-5507-08	CHASSIS/REAR	BCCS-0571-01	KP
605	2C	*	A23-5508-08	CHASSIS/REAR	BCCS-0572-02	Y
605	2C	*	A23-5509-08	CHASSIS/REAR	BCCS-0572-01	M
605	2C	*	A23-5510-08	CHASSIS/REAR	BCCS-0571-02	E
606	1B	*	A70-0409-08	REMOTE CONTROL		
610	2A	*	B06-1497-08	GRILLE ASSY		B
610	2A	*	B06-1498-08	GRILLE ASSY		W
611	1A	*	B19-1289-08	SENSOR LENS	BDDS-0111-01	
612	1A	*	B19-1290-08	POWER/PEAK LENS,BDDS-0110-01		
613	1A	*	B19-1291-08	CINEMA/NORM LENS,BDDS-0112-01		
△ 620	1B	*	E03-0115-05	AC PLUG ADAPTER		M
621	1B	*	E30-5860-08	AUDIO CORD		KP
△ 622	1C	*	E30-5863-05	POWER CORD	WPLU-HPC30008	Y
△ 622	1C	*	E30-5864-05	POWER CORD	WPLU-HPC30007	ME
△ 622	1C	*	E30-5865-05	POWER CORD	WPLU-HPC30005	
623	1A,2A	*	E36-0367-08	CARD CABLE	WFCB-FPC01503	
624	2A,2B	*	E36-0368-08	CARD CABLE	WFCB-FPC01504	
645	1A	*	K29-0587-08	CONTROL BUTTON	BDBT-0015-01	B
645	1A	*	K29-0588-08	CONTROL BUTTON	BDBT-0014-01	W
646	2A	*	K23-0542-08	CONTROL KNOB	BDBT-0013-01	B
646	2A	*	K23-0546-08	CONTROL KNOB	BDBT-0012-01	W
647	1A	*	K29-0585-08	POWER BUTTON	BDBT-0012-01	B
647	1A	*	K29-0589-08	POWER BUTTON	BDBT-0013-01	W
648	2A	*	K29-0586-08	VOLUME KNOB	BDBT-0018-01	B
648	2A	*	K29-0591-08	VOLUME KNOB	BDBT-0019-01	W
△ 650	2B	*	L07-3032-05	MAIN TRANS	TTG2-EPT60010	KPMY
△ 650	2B	*	L07-3035-05	MAIN TRANS	TTG2-EPT60011	E
-	-	*	B46-0310-03	WARRANTY CARD		E
-	-	*	B46-0328-03	WARRANTY CARD		KY
-	-	*	B46-0347-03	WARRANTY CARD		P
-	-	*	B59-1104-00	SERVICE STATIONS' LIST		Y
-	-	*	B61-1083-10	INSTRUCTION MANUAL		KPE
-	-	*	B61-1084-00	INSTRUCTION MANUAL		YM
-	-	*	H10-8176-08	POLYSTYRENE FIXTURE, TOP, FRNT		
-	-	*	H10-8177-08	POLYSTYRENE FIXTURE, BTM, FRNT		
-	-	*	H10-8189-08	POLYSTYRENE FIXTURE, TOP, REAR		
-	-	*	H10-8190-08	POLYSTYRENE FIXTURE, BTM, REAR		
-	-	*	H51-1527-08	ITEM CARTON CASE		KPYE
-	-	*	H51-1528-08	ITEM CARTON CASE		M
SP1	2A	*	T10-0962-05	WOOFER		
△ SW1	1A	*	S90-0203-08	POWER SWITCH	ESPP-KDCA04	
△ SW2	1C	*	S62-0214-08	SLIDE SWITCH	ESSL-SSB040	MY
ELECTRICAL PARTS						
LED501-3		*	B30-1835-08	LED	SDLB-SLR34V3	
LED504		*	B30-1836-08	LED	SDLB-SPR39MV	
LED505,6		*	B30-1835-08	LED	SDLB-SLR34V3	
C101,2			CE04CW1C100M	ELECTRO	10UF 16WV	

L : Scandinavia K : USA P : Canada R : Mexico C : China I : Malaysia
Y : PX(Far East,Hawaii) T : England E : Europe G : Germany V : China(Shanghai)
Y : AAFES(Europe) X : Australia Q : Russia H : Korea M : Other Areas △ indicates safety critical components .

* New Parts
Parts without **Parts No.** are not supplied.
Les articles non mentionnés dans le **Parts No.** ne sont pas fournis.
Teile ohne **Parts No.** werden nicht geliefert.

②

Ref. No	Add-ress	New Parts	Parts No.	Description	Desti-nation	Re-marks
C103			CK45FB1H101K	CERAMIC	100PF	K
C104			CE04CW1C100M	ELECTRO	10UF	16WV
C105-7			CK45FB1H101K	CERAMIC	100PF	K
C108			CE04CW1C470M	ELECTRO	47UF	16WV
C109			CE04CW1C470M	ELECTRO	47UF	16WV
C110			CE04CW1C100M	ELECTRO	10UF	16WV
C111			CE04CW1C470M	ELECTRO	47UF	16WV
C120			CE04CW1C470M	ELECTRO	47UF	16WV
C121,2			CE04CW1H010M	ELECTRO	1.0UF	50WV
C125			C91-0213-08	FILM	0.18UF	63WV
C126		*	C90-5132-08	FILM	0.082UF	63WV
C127		*	C90-5133-08	FILM	0.15UF	63WV
C128			CE04CW1C100M	ELECTRO	10UF	16WV
C129			CE04CW1H010M	ELECTRO	1.0UF	50WV
C130			CE04CW1C100M	ELECTRO	10UF	16WV
C131,2			CE04CW1C470M	ELECTRO	47UF	16WV
C133,4			CE04CW1C100M	ELECTRO	10UF	16WV
C135			CE04CW1C470M	ELECTRO	47UF	16WV
C137-9			CE04CW1C100M	ELECTRO	10UF	16WV
C140			CE04CW1H010M	ELECTRO	1.0UF	50WV
C141			CE04CW1C220M	ELECTRO	22UF	16WV
C142			CE04CW1C100M	ELECTRO	10UF	16WV
C150			CK45FB1H104K	CERAMIC	0.10UF	K
C151,2			CK45FF1H472Z	CERAMIC	4700PF	Z
C153-6			CK45FB1H222K	CERAMIC	2200PF	K
C201			CE04CW1C100M	ELECTRO	10UF	16WV
C202			CK45FB1H471K	CERAMIC	470PF	K
C203,4			CE04CW1C100M	ELECTRO	10UF	16WV
C205			CK45FB1H221K	CERAMIC	220PF	K
C206			CK45FB1H102K	CERAMIC	1000PF	K
C207			CE04CW1E100M	ELECTRO	10UF	25WV
C208			CK45FB1H102K	CERAMIC	1000PF	K
C209			CE04CW1H010M	ELECTRO	1.0UF	50WV
C210			CE04CW1C100M	ELECTRO	10UF	16WV
C211,2		*	C90-5135-08	FILM	0.22UF	250WV
C213		*	C90-5136-08	FILM	0.068UF	250WV
C214		*	CK45FB1H104K	CERAMIC	0.10UF	K
C215		*	C90-5135-08	FILM	0.22UF	250WV
C216		*	C90-5137-08	FILM	1UF	250WV
C217		*	CK45FB1H222K	CERAMIC	2200PF	K
C218		*	C90-5137-08	FILM	1UF	250WV
C219		*	CK45FB1H471K	CERAMIC	470PF	K
C220		*	C90-5135-08	FILM	0.22UF	250WV
C221		*	CK45FB1H471K	CERAMIC	470PF	K
C224-1		*	C90-5137-08	FILM	1UF	250WV
C224,5		*	C90-5137-08	FILM	1UF	250WV
C225-1		*	C90-5137-08	FILM	1UF	250WV
C226		*	C90-5138-08	FILM	0.47UF	250WV
C227		*	CK45FB1H104K	CERAMIC	0.10UF	K
C228,-30		*	C90-5135-08	FILM	0.22UF	250WV
C231			CK45FB1H103K	CERAMIC	0.010UF	K
C232			CE04DW1E102M	ELECTRO	1000UF	25WV
C233		*	C90-5139-08	ELECTRO	1000UF	80WV
C234			CE04CW1E101M	ELECTRO	100UF	25WV
C235			CE04CW1H010M	ELECTRO	1.0UF	50WV

L : Scandinavia K : USA P : Canada R : Mexico C : China I : Malaysia
Y : PX(Far East,Hawaii) T : England E : Europe G : Germany V : China(Shanghai)
Y : AAFES(Europe) X : Australia Q : Russia H : Korea M : Other Areas △ indicates safety critical components .

SW-505D-S/505D-W

PARTS LIST

* New Parts
Parts without **Parts No.** are not supplied.
Les articles non mentionnés dans le **Parts No.** ne sont pas fournis.
Teile ohne **Parts No.** werden nicht geliefert.

Ref. No	Add-ress	New Parts	Parts No.	Description	Desti-nation	Re-marks
D205-10			1N4148	DIODE		
D213-20			EL1Z	DIODE		SDFB-EL1Z
D221-4			1N4001	DIODE		
D225,6			EL1Z	DIODE		SDFB-EL1Z
D301			KBL10	DIODE		
D302			1N4148	DIODE		
D303-9			1N4001	DIODE		
D310			1N4148	DIODE		
D311,2			MTZJ10B	ZENER DIODE		
D313-6			1N4001	DIODE		
D317			1N4148	DIODE		
D319			1N4148	DIODE		
D370,1			1N4148	DIODE		
D501			1N4148	DIODE		
DZ201,2			MTZJ3.3B	ZENER DIODE		
DZ211,2			MTZJ3.3B	ZENER DIODE		
IC101-4			BA4558N	IC(OP AMP X2)		
IC105			LM393	IC		
IC201			LM393	IC		
IC202,3			UPC4570C	IC(OP AMP X2)		
△ IC204		*	HIP4080A	IC		
△ IC205		*	KA7812	IC		
IC301		*	KS57P0504N	IC		
△ IC302		*	MC7805	IC		
△ IC303		*	KA7812L	IC		
△ IC304		*	KA7912L	IC		
IC401			BA6208	IC(MOTOR DRIVER)		
△ PT501		*	RPM-6938CBR-L	IC		
Q202			KTC3198Y	TRANSISTOR		
Q203			KTA1023Y	TRANSISTOR		
△ Q204		*	DTA124ES	TRANSISTOR		
Q207-10		*	IRF540	FET		
Q211		*	DTC114ES	TRANSISTOR		
Q212		*	2SC2874	TRANSISTOR		
TR101		*	DTA114ES	TRANSISTOR		
TR102		*	2SC2874	TRANSISTOR		
TR103,4		*	DTA114ES	TRANSISTOR		
TR105		*	2SC2874	TRANSISTOR		
TR106,7		*	DTA114ES	TRANSISTOR		
TR108		*	2SC2874	TRANSISTOR		
TR301,2			DTA114ES	TRANSISTOR		
TR304			DTC114ES	TRANSISTOR		
TR305			KTC3198Y	TRANSISTOR		
TR306			DTC114ES	TRANSISTOR		
TR307			KTC3198Y	TRANSISTOR		
TR308			DTC114ES	TRANSISTOR		
TR309			KTC3198Y	TRANSISTOR		
TR310			DTC114ES	TRANSISTOR		
TR311			KTC3198Y	TRANSISTOR		
TR370			KTA1023Y	TRANSISTOR		
TR501			KTC3198Y	TRANSISTOR		

L : Scandinavia K : USA P : Canada R : Mexico C : China I : Malaysia
Y : PX(Far East,Hawaii) T : England E : Europe G : Germany V : China(Shanghai)
Y : AAFES(Europe) X : Australia Q : Russia H : Korea M : Other Areas △ indicates safety critical components .

* New Parts
Parts without **Parts No.** are not supplied.
Les articles non mentionnés dans le **Parts No.** ne sont pas fournis.
Teile ohne **Parts No.** werden nicht geliefert.

Ref. No	Add-ress	New Parts	Parts No.	Description	Desti-nation	Re-marks
C236			CK45FB1H104K	CERAMIC 0.10UF K		
C237			CK45FB1H222K	CERAMIC 2200PF K		
C238			CK45FB1H104K	CERAMIC 0.10UF K		
C302		*	C90-5140-08	ELECTRO 4700UF 80WV		
C303			CC45FCH1H330J	CERAMIC 33PF J		
C304		*	CE04CW1H010M	ELECTRO 1.0UF 50WV		
C305			C90-5141-08	BACKUP C 0.047F 5.5WV		
C309			CE04CW1C101M	ELECTRO 100UF 16WV		
C310			CE04CW1C102M	ELECTRO 1000UF 16WV		
C311			CE04CW1C100M	ELECTRO 10UF 16WV		
C312			CE04CW1C101M	ELECTRO 100UF 16WV		
C313			CK45FB1H103K	CERAMIC 0.010UF K		
C314,5			CE04KW1E471M	ELECTRO 470UF 25WV		
C316-8			CE04CW1C100M	ELECTRO 10UF 16WV		
C319			CE04CW1H2R2M	ELECTRO 2.2UF 50WV		
C320			CC45FCH1H330J	CERAMIC 33PF J		
C330			CK45FB1H104K	CERAMIC 0.10UF K		
C331			CK45FB1H103K	CERAMIC 0.010UF K		
C332			CK45FB1H104K	CERAMIC 0.10UF K		
C333,4			CK45FB1H103K	CERAMIC 0.010UF K		
C370			CE04CW1H2R2M	ELECTRO 2.2UF 50WV		
C401-3			CE04CW1C100M	ELECTRO 10UF 16WV		
C404		*	C90-5142-08	FILM 0.27UF 63WV		
C405			CK45FB1H103K	CERAMIC 0.010UF K		
C406			CE04CW1C100M	ELECTRO 10UF 16WV		
C501			CE04CW0J101M	ELECTRO 100UF 6.3WV		
C502			CE04CW1C100M	ELECTRO 10UF 16WV		
CN3B		*	E41-0502-08	FPC CONNECTOR HFPC-8370-157		
CN501		*	E41-0502-08	FPC CONNECTOR HFPC-8370-157		
CON32,3		*	E41-0502-08	FPC CONNECTOR HFPC-8370-157		
J101		*	E63-0205-08	RCA JACK JJR2-JE020059		
T101		*	E70-0205-08	SCREW TERMINAL FTS8-PPT00803		
△ F101			F53-0224-08	FUSE 2.5A FFAD-CUL522R5	KPMY	
△ F102			F53-0223-08	FUSE 1.25A FFAD-CUL521R2	MEY	
L1 ,2		*	L90-0404-08	MOIDED TYPE COIL.ICCM-EMI1630		
L204,5		*	L90-0405-08	COIL ICCR-ERC02704		
L206,7		*	L90-0406-08	COIL ICCR-ERC01802		
△ T301	2C	*	L07-3036-08	SUB TRANS TTG2-EPT60012	KPYM	
△ T301	2C	*	L07-3037-08	SUB TRANS TTG2-EPT60013	E	
X301		*	L71-0102-08	CRYSTAL,4MHZ EXVB-4R000		
R241			RD14BB2H330J	RD 33 J 1/2W		
R245			RS14GB3F0R1K	FL-PROOF RS 0.1 K 3W		
R302			RD14BB3A220J	RD 22 J 1W		
VR201		*	R32-0403-08	TRIMMING POT RSVB-CET68103		
VR401		*	R31-0420-08	POTENTIOMETER RVRM-SBR2060		
VR402		*	R31-0421-08	POTENTIOMETER RVRM-SBR2001		
△ RELAY		*	S76-0209-08	RELAY ER22-G5PA2-12		
SW402		*	S60-0203-08	ROTARY ESRL-10H13NS2		
SW501,2		*	S70-0204-08	TACT SWITCH ESTS-KHH10910		
D101-6			1N4148	DIODE		
D109,10			1N4148	DIODE		
D151-6			1N4148	DIODE		

L : Scandinavia K : USA P : Canada R : Mexico C : China I : Malaysia
Y : PX(Far East,Hawaii) T : England E : Europe G : Germany V : China(Shanghai)
Y : AAFES(Europe) X : Australia Q : Russia H : Korea M : Other Areas △ indicates safety critical components .

Note:
Component and circuit are subject to modification to insure best operation under dif-fering local conditions. This manual is based on Europe (E) standard, and provides information on regional circuit modification through use of alternate schematic dia-grams, and information on regional component variations through use of parts list.

KENWOOD CORPORATION

14-6,Dogenzaka 1-chome, Shibuya-ku, Tokyo, 150-8501 Japan
KENWOOD SERVICE CORPORATION
P.O BOX 22745, 2201 East Dominguez St., Long Beach, CA 90801-5745, U.S.A.