

T-93/93L

SERVICE MANUAL

KENWOOD

©1989-8 PRINTED IN JAPAN
B51-3958-00(T)1702

64818

30K2

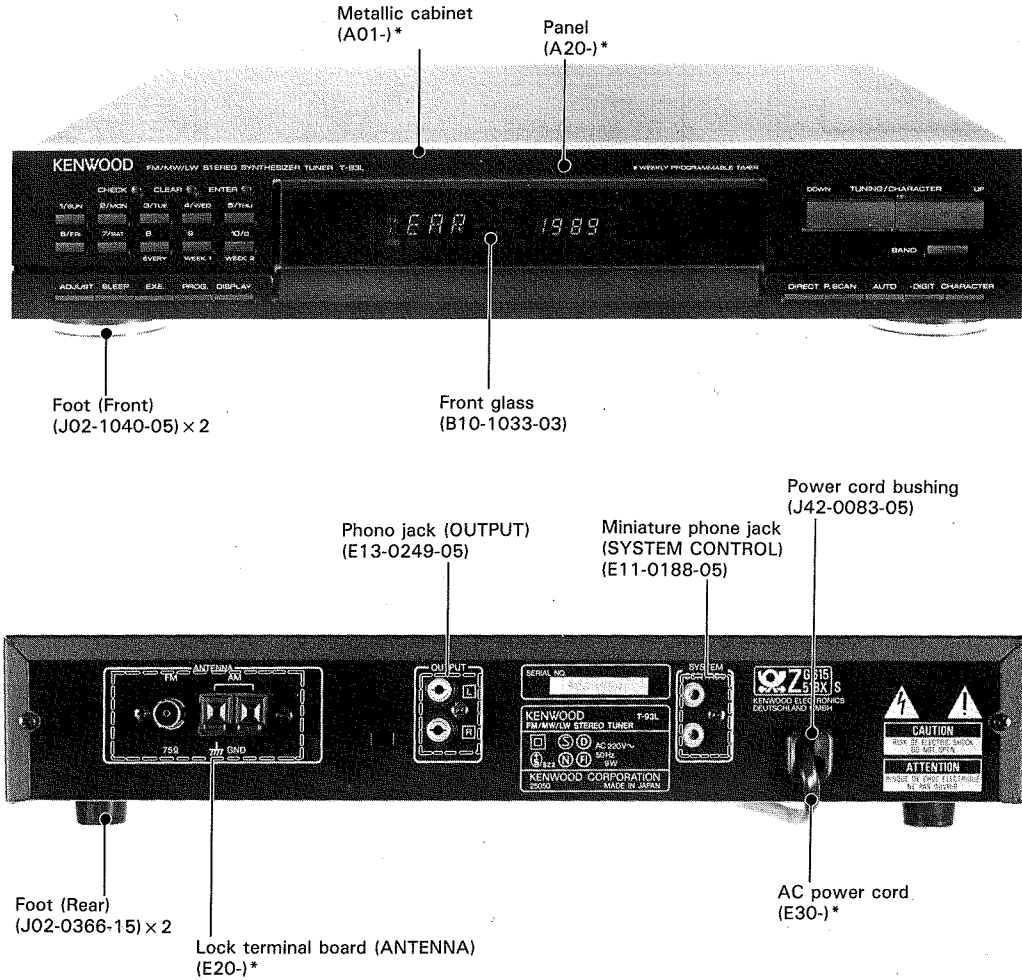

* Refer to Parts List on page 44.
Photo is T-93L

MODEL NAME	TYPE	TUNER UNIT (X05)	DISPLAY UNIT (X14)	POWER TRANSFORMER (L01)	FRONT END (X86)
T-93 (J)	M	X05-3780-20	X14-2620-21	L01-5454-15	X86-1040-10
T-93 (J)	X	X05-3780-71	X14-2620-71	L01-5452-05	X86-1040-10
T-93L (J)	T,E	X05-3782-71	X14-2622-71	L01-5452-05	X86-1052-70
T-93L (J)	EF,TF	X05-3782-72	X14-2622-72	L01-5452-05	X86-1052-70
T-93 (S)	M	X05-3780-21	X14-2630-20	L01-9004-05	X86-1130-10
T-93 (S)	X	X05-3780-72	X14-2630-71	L01-9002-05	X86-1130-10
T-93L (S)	T,E	X05-3782-73	X14-2632-71	L01-9002-05	X86-1122-70

CONTENTS

CONTROLS AND INDICATORS.....	3	REGLAGES	16
ANTENNA CONNECTION	4	ABGLEICH	17
BLOCK DIAGRAM	5	VOLTAGE TABLES	18
FUNCTION OF EACH IC's.....	6	PC BOARD (T-93).....	19
CIRCUIT DESCRIPTION.....	7	PC BOARD (T-93L).....	27
Operation specification.....	7	SCHEMATIC DIAGRAM (T-93).....	35
IC1: CXP50112-010Q (X14-).....		SCHEMATIC DIAGRAM (T-93L).....	39
MICROPROCESSOR	8	EXPLODED VIEW	43
IC1: LM7001 (X05-378X-XX).....		PARTS LIST.....	44
PLL CONTROL DATA.....	12	SPECIFICATIONS.....	Back cover
ADJUSTMENT.....	15		

CONTROLS AND INDICATORS

Tuner

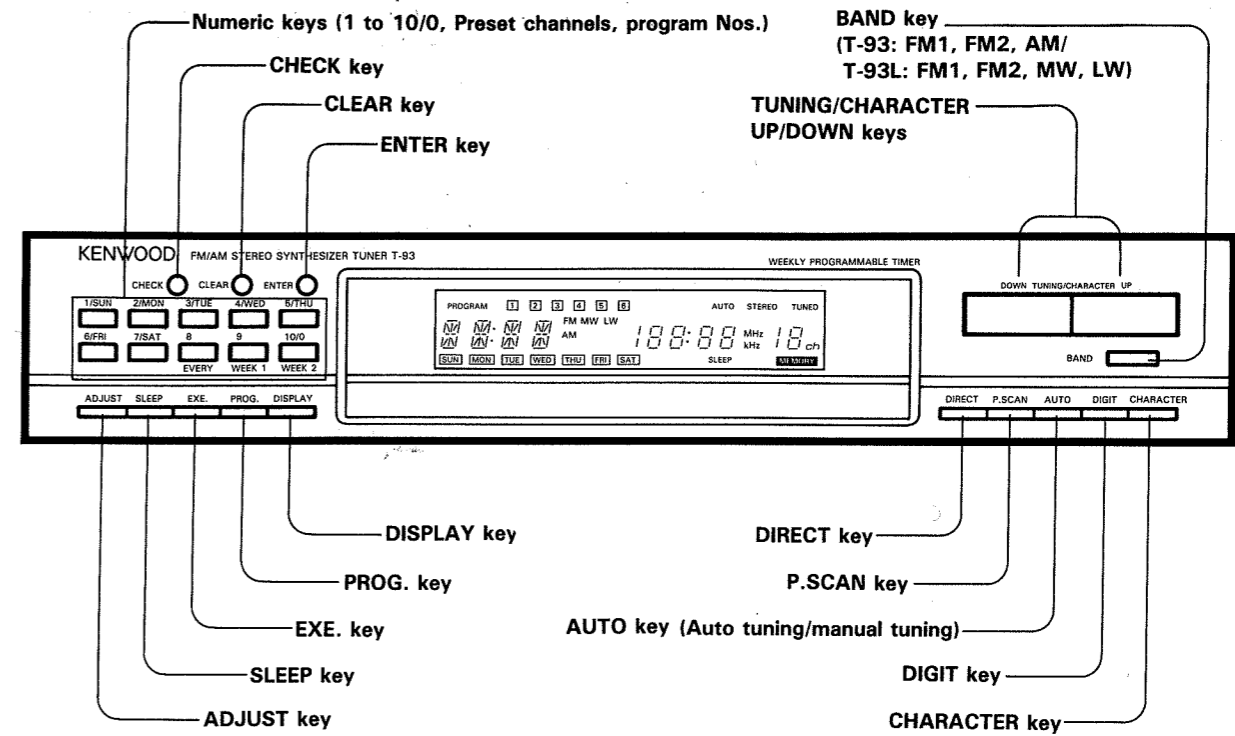

Display panel

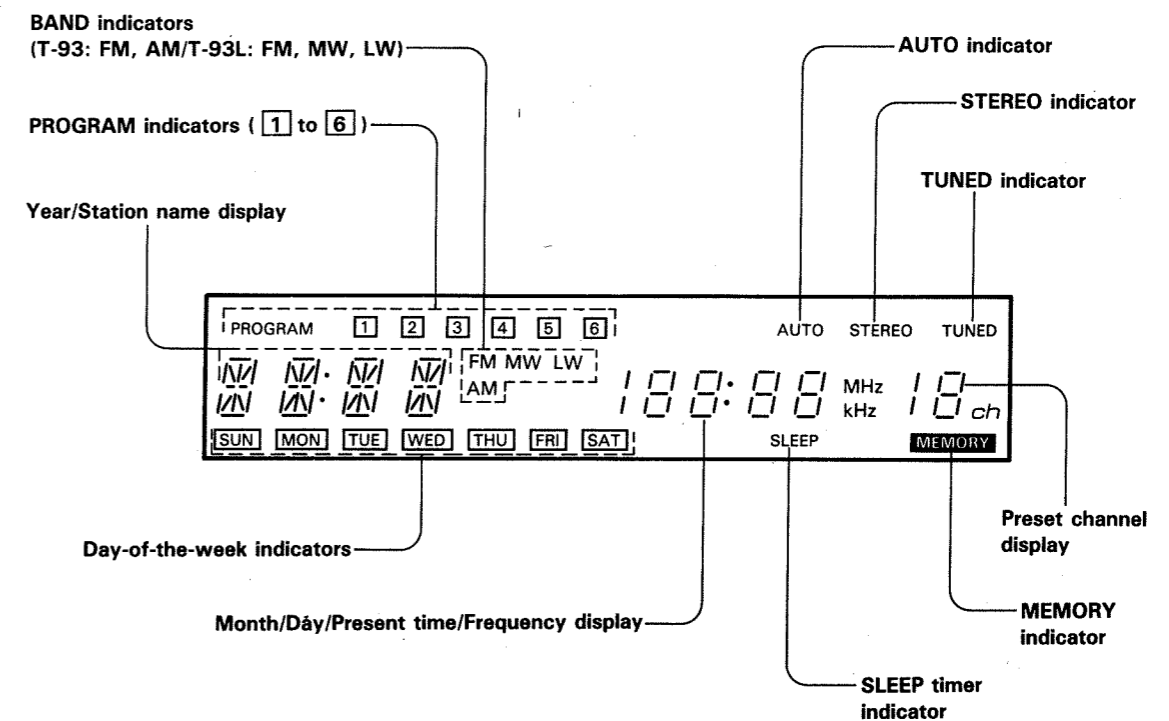

ANTENNA CONNECTION

Antenna connections

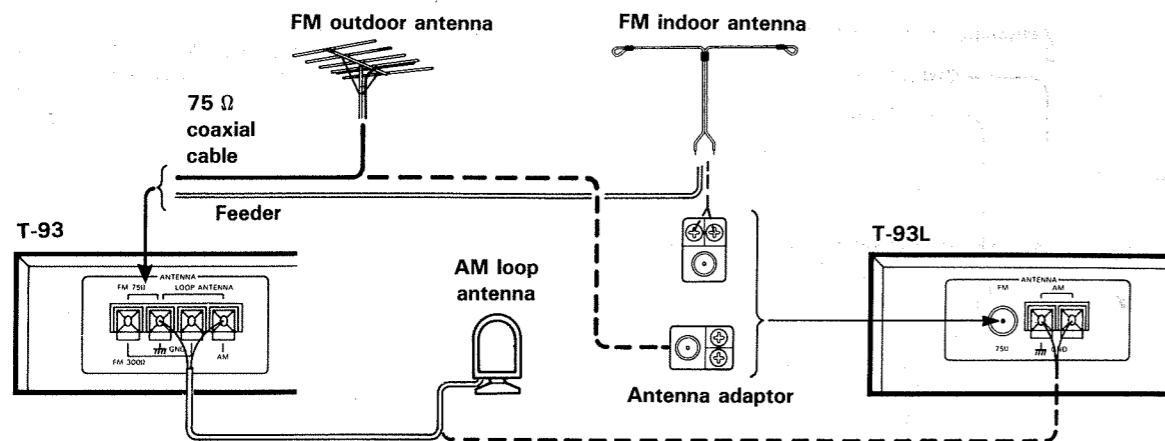

AM (MW, LW) loop antenna

Install the AM (MW, LW) loop antenna on the supplied loop antenna stand and place it on a shelf, etc., or install it on the rack or wall with screws. Rotate the AM (MW, LW) loop antenna to the right or left for best reception.

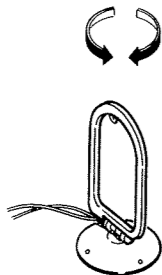

Keep the speaker leads and AC cords away from the AM loop antenna.

Note:
Do not place the AM (MW, LW) loop antenna on the unit. As this unit employs a computing device, placing the AM (MW, LW) loop antenna on the unit may result in noise generation. Place the AM (MW, LW) loop antenna away from the unit.

AM (MW, LW) outdoor antenna

In steel buildings or at a great distance from the transmitter, it may be necessary to install an outside longwire antenna. The end of this wire should be stripped of insulation and connected to the AM terminal. At this time, keep the loop antenna connected.

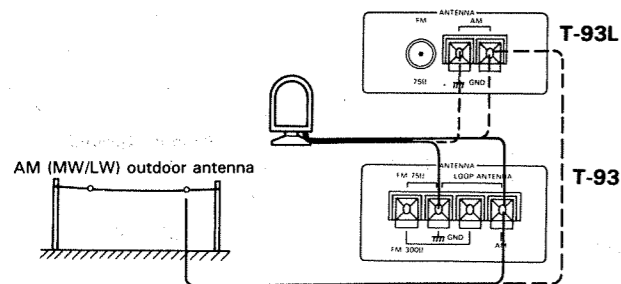

FM outdoor antenna

It is recommended to install an exclusive FM outdoor antenna to capture FM broadcasts with high sound quality. Use a coaxial cable for the connection between the outdoor antenna and FM ANTENNA terminal on the rear panel. For the connection between the coaxial cable and FM ANTENNA terminal, please refer to the illustration above.

FM indoor antenna

In areas where FM waves are strong, FM broadcasts can be received by connecting the supplied T-shaped antenna as shown in the illustration above. However, as FM waves are susceptible to external radio interference causing distortion, it is recommended to use an exclusive FM outdoor antenna.

- To minimize auto-ignition noise, locate the antenna as far from heavy traffic as possible.
- Keep the feeder or coaxial cable as short as possible. Do not bundle or roll up excess cable.
- The antenna should be at least two meters (6.6 feet) from reinforced concrete walls, or metal structures.

FM outdoor antenna setting

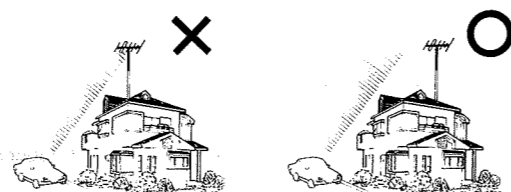

BLOCK DIAGRAM

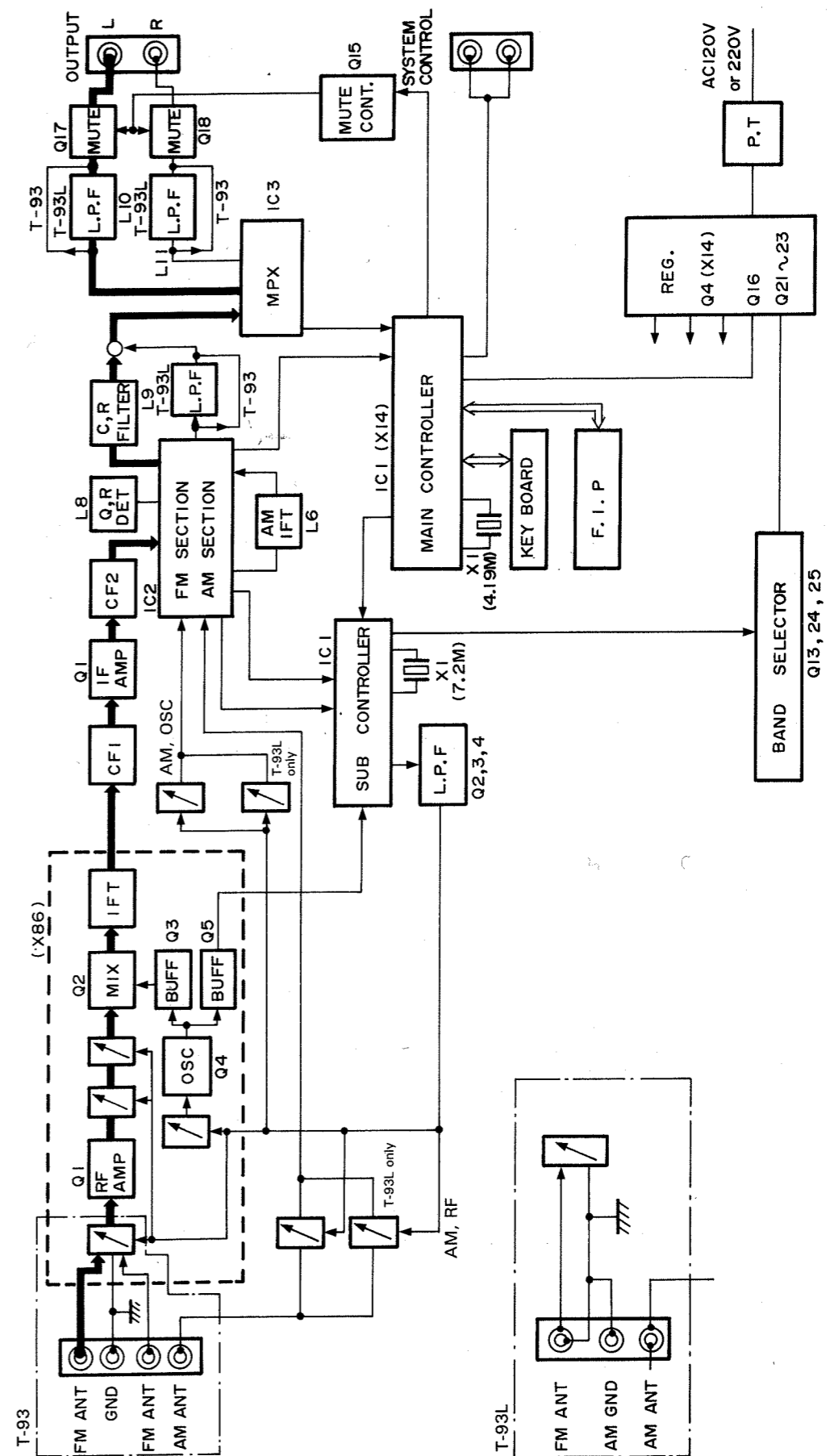

FUNCTION OF EACH IC's

CIRCUIT DESCRIPTION

TUNER UNIT (X05-378X-XX)

Ref. No.	Components	Use/Function	Operation/Condition/Compatibility
IC1	LM7001	PLL IC	Electronic tuning PLL
IC2	LA1265	FM/AM system IC	FM IF amplification, detection, and AM MIX, IF amplification, detection, control
IC3	AN7470	FM MPX IC	MPX demodulation
Q1	2SC1923	FM IF amplifier	10.7 MHz amplification
Q2	2SC1740S	L.P.F.	PLL low-pass filter JC501/2SC945(A)
Q3	2SC1845	L.P.F.	PLL low-pass filter
Q4 (T-93L)	2SK163	L.P.F. switch	Time constant selection for LW mode 2SK364
Q6 (T-93L)	2SC1740S	L.P.F. control	Control over Q4. LW position with switch ON JC501/2SC945(A)
Q7 (T-93L)	2SC1740S	Antenna coil selection	LW/MW electronic selectionz JC501/2SC945(A)
Q8 (T-93L)	2SC1740S		
Q11 (T-93L)	2SC1740S	Buffer	Impedance change JC501/2SC945(A)
Q13	2SA733(A)	Tuner band selection	FM/MW/LW power selection JA101/2SA933S
Q24	2SA733(A)		
Q25	2SA733(A)		
Q15	2SA733(A)	Mute control	Mute ON with signal "L" from microprocessor 2SA933S
Q16	2SC2003	Constant voltage	+ 5.6 V regulated
Q17	2SD1302	Mute switch	ON in function selection
Q18	2SD1302		
Q19 (T-93)	2SC1740S	Deemphasis selection	Deemphasis time constant selection for FM mode 2SC945(A)
Q20 (T-93)	2SC1740S		
Q21	2SD1266	Constant voltage	+ 13 V regulated
Q22	2SA733(A)	Power switch	Power ON/OFF operation 2SA933S/JA101
Q23	2SC1740S	Control	Power ON with signal "H" from microprocessor JC501/2SC945(A)

**DISPLAY UNIT (X14-262X-XX) JAPAN MADE
(X14-263X-XX) SINGAPORE MADE**

Ref. No.	Components	Use/Function	Operation/Condition/Compatibility
IC1	CXP50112-010Q	4-bit microprocessor	Controller for PLL and display, etc.
Q1	2SC1740S	FIP Driver	FIP Indication (STEREO, TUNED, ch etc.) JC501/2SC945(A)
Q2	2SC1740S	FIP Driver	FIP Indication (FM, AM, etc.) JC501/2SC945(A)
Q3	2SA733(A)	Tr. SW	CHANNEL SPACE select 2SA933S
Q4	2SA733(A)	Constant voltage	For +5 V JA101/2SA933S
Q5	2SC1740S	Microprocessor Reset	Suplies reset pulse to microprocessor JC501/2SC945(A)

OPERATION SPECIFICATION

Functions

(1) Tuner section

a) Auto tuning

When the "AUTO" display is lighting, the tuning operation starts with the UP or DOWN key pressed. This operation continues in the direction of increasing or decreasing frequency at a rate of approx. 125 msec/step until the SD terminal becomes "L" (in which "TUNED" lights). When an input is obtained, the operation is stopped, after which, 0.5 sec later, muting is turned OFF.

b) Manual tuning

When the "AUTO" display is off, when the UP or DOWN key is pressed, the tuning operation goes in the direction of increasing or decreasing frequency at a rate of one step per key pressure.

When the UP or DOWN key is pressed continuously for more than 0.5 sec, the tuning operation continues in the direction of increasing or decreasing direction at a rate of 125 msec/step irrespective of the SD terminal level until the key is released from the finger pressure.

c) Direct tuning

The frequency whose data has been directly input from numeral keys is received. About how to input the frequency data, press the DIRECT key, then input the frequency value from numeral keys.

When the input frequency is within the specified band, this frequency is received soon after the input of its final digit, While when it is without the specified band, an error display appears for 5 seconds, after that the original display is restored.

d) Preset memory

For each band, 10 stations can be preset. Their station names, each consisting of up to 4 characters, can all be memorized at the same time.

Only the FM mode permits memory of 10 more stations. In this case, however, their station names cannot be input.

e) Preset scan

This function is to receive the preset stations successively. With a tuning signal, muting is turned OFF for 5 seconds, while with no tuning signal, the tuning operation shifts to the next station after 1 second.

f) Station name display

For a preset memory, up to 4 characters can be input for a station name. When the wanted one is called from the preset memory, that station name is displayed. Inputtable characters are alphanumeric A to Z and 0 to 9, and 6 special characters including "--" (blank). In addition, FM2 does not permit input.

(2) Timer section

a) Day timer

A timer function with the unit count of 7.8125 msec is provided. The time value is displayed in the 24-hour mode without flickering of the colon ":" after which the second data is displayed.

At first, when AC is applied, the display is initialized to "0:00".

When the power fails, all digits inclusive of the colon flicker to warn for readjustment.

b) Calendar

An auto calendar function of from January 1, 1900 to December 31, 2099 is provided. With year, month and day data is input, day-of-week setting is automatically made. When initialized, January 1 (Sunday)/1989 is engaged.

c) Calendar check

When year, month and day data is input, it is possible to know what day of the week that day is.

The inputtable range of data is the same as that for the calendar function.

d) Programmable timer

Six timer systems are provided to set the day of week, ON time, OFF time, band and preset channel, independently. As to the day of week, selection is possible from 10 patterns such as each day of week of Sunday to Saturday, every day, Monday to Saturday, and Monday to Friday.

e) Sleep timer

The sleep timer is an auto OFF timer of max. 90 minutes, which is capable of setting in units of 10 minutes. During the sleep timer operation, the "SLEEP" display is lighting. This timer is given priority over the programmable timer. The sleep timer is operable even when the day timer is not set.

CIRCUIT DESCRIPTION

IC1: CXP50112-010Q (X14-)
4-bit MICROPROCESSOR
Pin Connections (Top View)

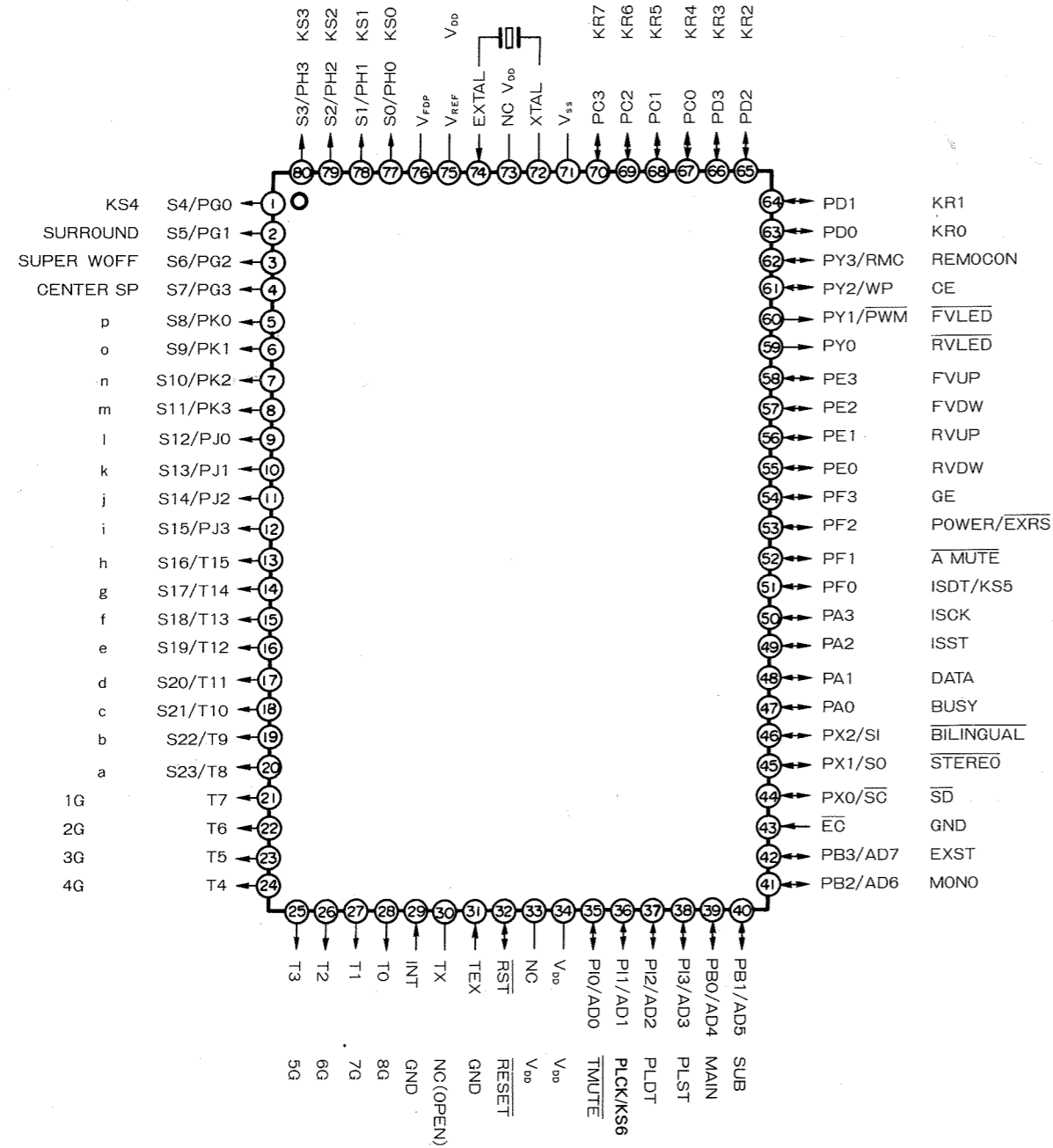

Note: The NC pins, pins 33 and 73, should be set to VDD.

CIRCUIT DESCRIPTION

Pin Functions:

Pin No.	Pin name	I/O	Name	Operation description	
1	S4/PG0	O	KS4	Key scan output	H: ON L: OFF
2	S5/PG1	O	SURROUND	SURROUND ON/OFF	H: ON L: OFF
3	S6/PG2	O	SUPER WOFFER	SUPER WOFFER ON/OFF	H: ON L: OFF
4	S7/PG3	O	CENTER	CENTER OUTPUT ON/OFF	H: ON L: OFF
5	S8/PK0	O	S8	FL segment output	p H: ON L: OFF
6	S9/PK1	O	S9	FL segment output	o H: ON L: OFF
7	S10/PK2	O	S10	FL segment output	n H: ON L: OFF
8	S11/PK3	O	S11	FL segment output	m H: ON L: OFF
9	S12/PJ0	O	S12	FL segment output	l H: ON L: OFF
10	S13/PJ1	O	S13	FL segment output	k H: ON L: OFF
11	S14/PJ2	O	S14	FL segment output	j H: ON L: OFF
12	S15/PJ3	O	S15	FL segment output	i H: ON L: OFF
13	S16/T15	O	S16	FL segment output	h H: ON L: OFF
14	S17/T14	O	S17	FL segment output	g H: ON L: OFF
15	S18/T13	O	S18	FL segment output	f H: ON L: OFF
16	S19/T12	O	S19	FL segment output	e H: ON L: OFF
17	S20/T11	O	S20	FL segment output	d H: ON L: OFF
18	S21/T10	O	S21	FL segment output	c H: ON L: OFF
19	S22/T9	O	S22	FL segment output	b H: ON L: OFF
20	S23/T8	O	S23	FL segment output	a H: ON L: OFF
21	T7	O	T7	FL grid output	G1 H: ON L: OFF
22	T6	O	T6	FL grid output	G2 H: ON L: OFF
23	T5	O	T5	FL grid output	G3 H: ON L: OFF
24	T4	O	T4	FL grid output	G4 H: ON L: OFF
25	T3	O	T3	FL grid output	G5 H: ON L: OFF
26	T2	O	T2	FL grid output	G6 H: ON L: OFF
27	T1	O	T1	FL grid output	G7 H: ON L: OFF
28	T0	O	T0	FL grid output	G8 H: ON L: OFF
29	INT	I	INT	External interrupt pin... unused	
30	TX	O	TX	Timer oscillation pin... unused	
31	TEX	I	TEX	Timer oscillation pin... unused	
32	RST	I	RESET	Reset input	H: Normal L: Reset
33	NC		NC		
34	VDD			Power supply pin	
35	PI0/AD0	O	TMUTE	Tuner section mute output	H: Mute OFF L: Mute ON
36	PI1/AD1	O	PLCK/KS6	Clock to PLL and extension IC, and key scan (for diode SW)	
37	PI2/AD2	O	PLDT	Data output to PLL and extension IC	
38	PI3/AD3	O	PLST	PLL chip enable output	
39	PB0/AD4	O	PMAIN	TV sound multiplex selection output	
40	PB1/AD5	O	PSUB	TV sound multiplex selection output	
41	PB2/AD6	O	PMONO	Stereo/mono selection	H: Mono L: Stereo
42	PB3/AD7	O	EXIO	Extension IC strobe signal	
43	EC	I	EC	Even counter input... unused	
44	PX0/SC	I	SD	Tuning signal input	H: OFF L: Tuned
45	PX1/SO	I	ST	Stereo signal input	H: Mono L: Stereo

CIRCUIT DESCRIPTION

Pin No.	Pin name	I/O	Name	Operation description	
46	PX2/SI	I	BIL	Bilingual signal input	H: Normal L: Bilingual
47	PA0	I/O	BUSY	System control busy	
48	PA1	I/O	DATA	System control data	
49	PA2	O	ISST	Input selector IC strobe output	
50	PA3	O	ISCK	Input selector IC clock output	
51	PF0	O	ISDT/KS5	Input selector IC data/key scan	
52	PF1	O	AMUTE	Amplifier section mute output	H: Mute OFF L: Mute ON
53	PF2	O	POWER/EXRS	Power control/extension IC reset output	H: ON (reset OFF) L: OFF (reset ON)
54	PF3	O	GE	Graphic equalizer display output	H: Graphic equalizer ON L: Graphic equalizer OFF
55	PE0	O	RVDW	Rear volume down	H: Down L: -
56	PE1	O	RVUP	Rear volume up	H: Up L: -
57	PE2	O	FVDW	Master volume down	H: Down L: -
58	PE3	O	FVUP	Master volume up	H: Up L: -
59	PY0	O	RVLED	Rear volume LED	H: OFF L: ON
60	PY1/PWM	O	FVLED	Master volume LED	H: OFF L: ON
61	PY2/WP	I	CE	AC ON/OFF detection input	H: ON L: OFF
62	PY3/RMC	I	RMCN	Remote control input	
63	PD0	I	KR0	Key return input	H: With input L: Without input
64	PD1	I	KR1	Key return input	H: With input L: Without input
65	PD2	I	KR2	Key return input	H: With input L: Without input
66	PD3	I	KR3	Key return input	H: With input L: Without input
67	PC0	I	KR4	Key return input	H: With input L: Without input
68	PC1	I	KR5	Key return input	H: With input L: Without input
69	PC2	I	KR6	Key return input	H: With input L: Without input
70	PC3	I	KR7	Key return input	H: With input L: Without input
71	Vss			GND pin	
72	XTAL	O	XTAL	Oscillator pin	
73	NC				
74	EXTAL	I	EXTAL	Oscillator pin	
75	VREF			Voltage detection reset pin... unused	
76	VFDP		VFDP	FL pin pull-down resistor power	
77	S0/PH0	O	KS0	Key scan output	H: ON L: OFF
78	S1/PH1	O	KS1	Key scan output	H: ON L: OFF
79	S2/PH2	O	KS2	Key scan output	H: ON L: OFF
80	S3/PH3	O	KS3	Key scan output	H: ON L: OFF

CIRCUIT DESCRIPTION

Blockdiagram of surrounding microprocessor

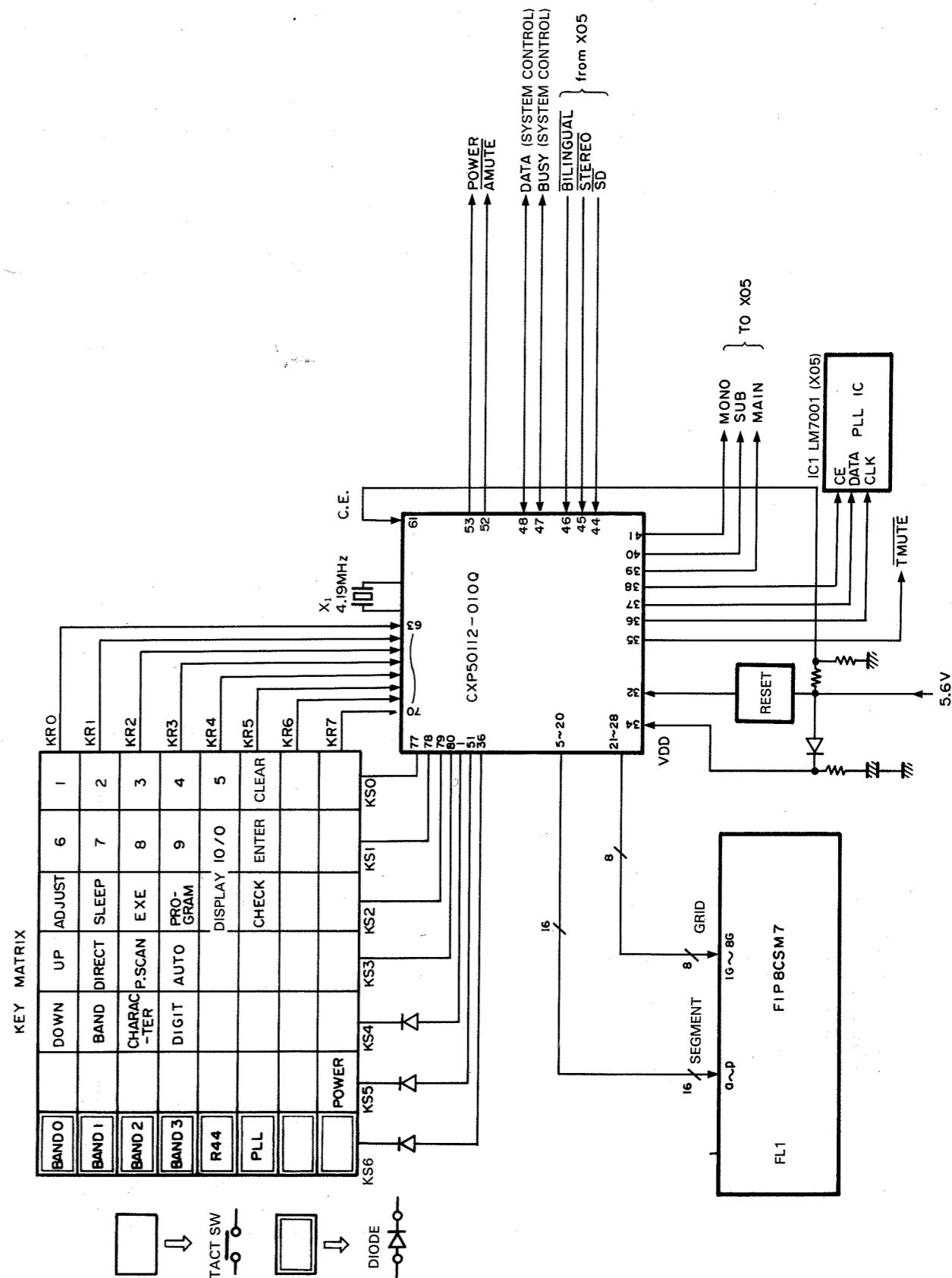

CIRCUIT DESCRIPTION

IC1: LM7001 (X05-378X-XX)
PLL CONTROL DATA

Band	Destination	Destination SW	Reception frequency range	Channel space	PLL reference frequency	Local OSC frequency	PLL input terminal	PLL port					P divider division ratio	Output data to PLL	Microprocessor memory data
								O0	O3	O4	O5	O6			
FM	J	0000	76.0 MHz 90.0 MHz	100 kHz	25 kHz	f - 10.7 MHz	FM IN, 1/2 prescaler inside and outside						28DH 319H	01407028DH 014070319H	0 ~ 118H
	K	10XX	87.5 MHz		25 kHz	f + 10.7 MHz	FM IN, 1/2 prescaler inside		1	1	1		7ACH 946H	0140707ACH 014070946H	0 ~ 19AH
	E	11XX	108.0 MHz	50 kHz	9 kHz								6DH 0E4H	0090E06D0H 0090E0E40H	0 ~ 77H
AM	J	0000	531 kHz 1602 kHz	9 kHz	9 kHz										
	E	11XX	1602 kHz		10 kHz	f + 450 kHz	AM IN	1	0	1	1		62H 0CEH	0080E0620H 0080E0CE0H	0 ~ 6CH
	K1	1000	530 kHz 1610 kHz	10 kHz	10 kHz								62H 0D7H	0080E0620H 0080E0D70H	0 ~ 75H
LW	E	1101	153 kHz 281 kHz	1 kHz	1 kHz	f + 450 kHz	AM IN	1	1	0	1		25BH 2DBH	00D1025B0H 00D102DB0H	0 ~ 80H
			95.75 MHz 107.75 MHz 175.75 MHz 221.75 MHz	6 MHz	12.5 kHz	f - 10.7 MHz	FM IN, 1/2 prescaler inside and outside	1	1	0	1		6A5H 795H	0121606A5H 012160795H	0 ~ 2H
TV (VH) 1~3			475.75 MHz 769.75 MHz		3.125 MHz		FM IN, 1/2 prescaler inside and 1/8 prescaler outside	1	1	1	0		0CE5H 107DH	012260CE5H 01226107DH	3H ~ BH
													2455H 3B4DH	016462455H 016463B4DH	0CH ~ 3DH

The output data to PLL refers to the stereo mode for FM/AM, to either the stereo or the monaural mode for TV, and to the monaural mode for LW.

CIRCUIT DESCRIPTION

Test mode

Tuner mode

- Method of setting**
While pressing the DOWN key, turn AC ON.
- Contents**
Power ON
FLL all lit
Test frequency setting (Table below)
- Method of canceling**
Clearing the FLL all lit state is performed by numeral key, band key, UP/DOWN key or POWER key.

Initial status setting (reset)

- Method**
While pressing the ENTER key, turn AC ON.
- Contents**
The all memory is cleared and the initial status is fully restored. At this time, however, test frequency is newly memorized in the preset memory. (This is the same as when backup data is not good.)

Band	Destination	Pch	J	K	E
FM (FM1)		1	76.0 MHz	87.5 MHz	87.5 MHz
		2	78.0 MHz	89.1 MHz	89.1 MHz
		3	80.0 MHz	90.0 MHz	90.0 MHz
		4	82.0 MHz	92.0 MHz	92.0 MHz
		5	83.0 MHz	94.0 MHz	94.0 MHz
		6	83.5 MHz	98.0 MHz	98.0 MHz
		7	86.0 MHz	100.1 MHz	100.1 MHz
		8	88.0 MHz	102.0 MHz	102.0 MHz
		9	89.1 MHz	106.0 MHz	106.0 MHz
		10	90.0 MHz	108.0 MHz	108.0 MHz
AM		1	531 kHz	530 kHz	531 kHz
		2	630 kHz	630 kHz	630 kHz
		3	990 kHz	990 kHz	990 kHz
		4	1440 kHz	1440 kHz	1440 kHz
		5	1602 kHz	1610 kHz	1602 kHz
		6	—	(1700 kHz)	—
TV/LW		1	1ch	—	153 kHz
		2	3ch	—	162 kHz
		3	4ch	—	216 kHz
		4	8ch	—	270 kHz
		5	12ch	—	281 kHz
		6	13ch	—	—
		7	35ch	—	—
		8	62ch	—	—

CIRCUIT DESCRIPTION

Time chart:

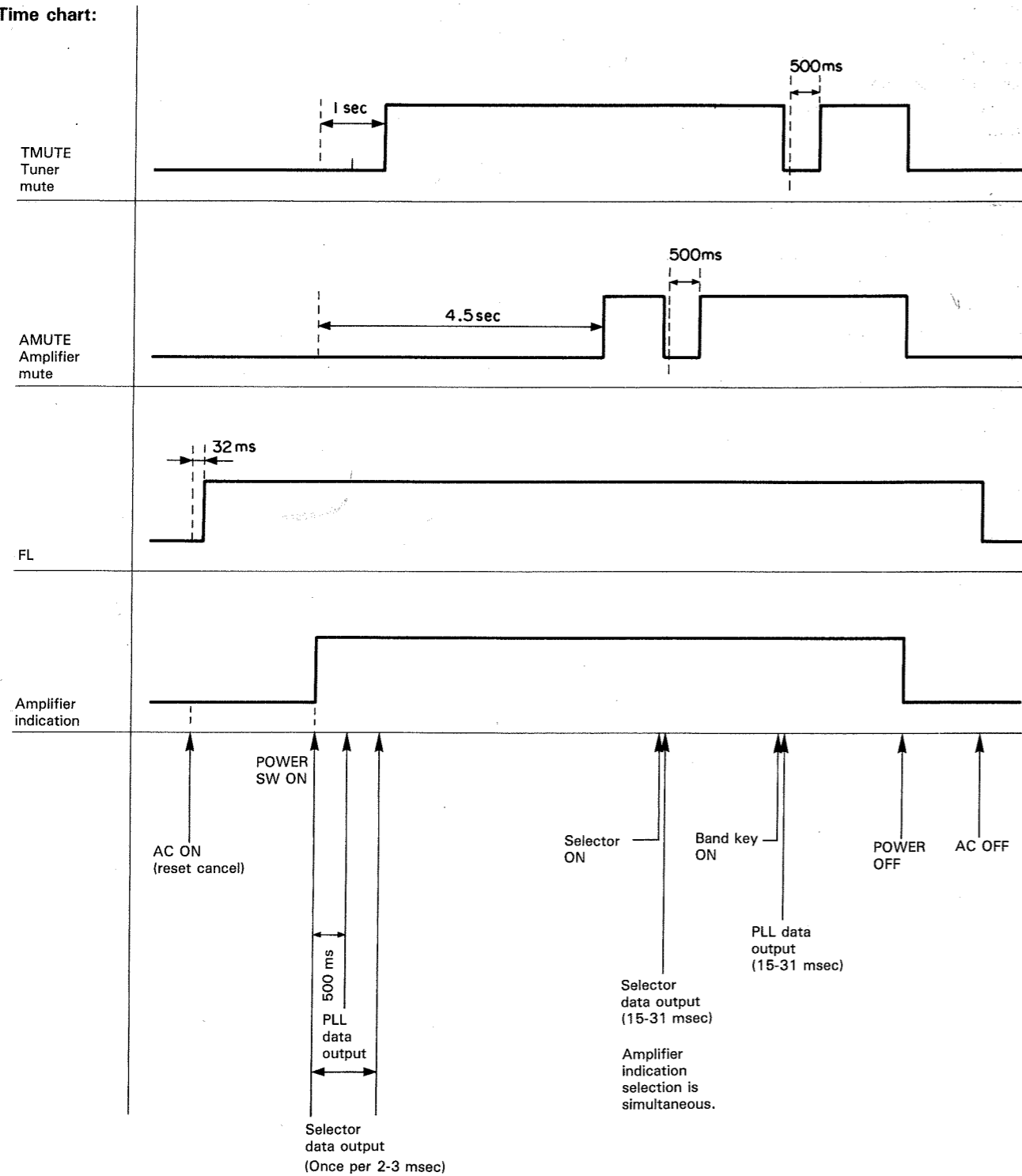

ADJUSTMENT

No.	ITEM	INPUT SETTINGS	OUTPUT SETTINGS	TUNER SETTINGS	ALIGNMENT POINTS	ALIGN FOR	FIG.
FM SECTION Unless otherwise specified, the individual switches should be set as following: SELECTOR: FM MODE: FM MODE/MUTING ON							
1	BAND EDGE (1)	-	Connect a DC voltmeter between TP5 (VT) and TP6 (GND).	87.5MHz	L7 (Front end)	2.5V	(a)
2	BAND EDGE (2)	-	Connect a DC voltmeter between TP5 (VT) and TP6 (GND).	108.0MHz	TC1 (Front end)	8.0V	(a)
Repeat alignments 1 and 2 several times.							
3	RF ALIGNMENT	(A) 98.0MHz 1kHz, ±75kHz dev	(B)	MONO 98.0MHz	L2,3,5* (Front end)	Maximum amplitude and symmetry of the oscilloscope display.	
4	DISCRIMINATOR	(A) 98.0MHz 1kHz, ±75kHz dev 60dBμ (ANT input)	Connect a DC voltmeter between TP7 and TP8.	MONO 98.0MHz	L8	0V	(b)
5	VCO	(A) 98.0MHz 0 dev 60dBμ (ANT input)	Connect a 330kΩ resistor to TP11. Connect a frequency counter to the resistor via an AC voltmeter.	98.0MHz	VR3	19.00kHz	(c)
6	DISTORTION (STEREO)	(C) 98.0MHz 1kHz, ±68.25kHz dev Selector: L or R 60dBμ (ANT input)	(B)	98.0MHz	L6 (Front end)	Minimum distortion. (L or R)	
7	TUNING LEVEL	(A) 98.0MHz 0 dev 18dBμ (ANT input)	-	98.0MHz	VR2	Adjust VR2 so that FL1(TUNED) goes off. Then, adjust VR2 and stop at the point where FL1(TUNED) goes on.	
AM-MW SECTION Keep the AM loop antenna installed. SELECTOR: AM(T-93) or MW(T-93L)							
(1)	BAND EDGE (1)	-	Connect a DC voltmeter between TP5 (VT) and TP6 (GND).	530kHz (531kHz)	L5	1.5V	(a)
(2)	BAND EDGE (2)	-	Connect a DC voltmeter between TP5 (VT) and TP6 (GND).	1610kHz (1602kHz)	TC4	8.0V	(a)
Repeat alignments (1) and (2) several times.							
(3)	RF ALIGNMENT (1)	(D) 630kHz 400Hz, 30% mod	(B)	630kHz	L3	Maximum amplitude and symmetry of the oscilloscope display.	
(4)	RF ALIGNMENT (2)	(D) 1440kHz 400Hz, 30% mod	(B)	1440kHz	TC2	Maximum amplitude and symmetry of the oscilloscope display.	
Repeat alignments (3) and (4) several times.							
AM-LW SECTION (T-93L only) Keep the AM loop antenna installed. SELECTOR: LW							
(5)	BAND EDGE (1)	-	Connect a DC voltmeter between TP5 (VT) and TP6 (GND).	153kHz	L4	1.5V	(a)
(6)	BAND EDGE (2)	-	Connect a DC voltmeter between TP5 (VT) and TP6 (GND).	281kHz	TC3	8.0V	(a)
Repeat alignments (5) and (6) several times.							
(7)	RF ALIGNMENT (1)	(D) 162kHz 400Hz, 30% mod	(B)	162kHz	L2	Maximum amplitude and symmetry of the oscilloscope display.	
(8)	RF ALIGNMENT (2)	(D) 270kHz 400Hz, 30% mod	(B)	270kHz	TC1	Maximum amplitude and symmetry of the oscilloscope display.	
Repeat alignments (7) and (8) several times.							

* L5: T-93L only

REGLAGES

N°	ITEM	REGLAGE DE L'ENTREE	REGLAGE DE LA SORTIE	REGLAGE DU TUNER	POINT DE L'ALIGNEMENT	ALIGNER POUR	FIG.
SECTION MF Sauf en cas d'indications spéciales, régler chaque commutateur comme suit: SELECTEUR: FM MODE: FM MODE/MUTING ON							
1	BORD DE BANDE (1)	-	Relier un voltmètre CC entre les TP5 (VT) et TP6 (GND).	87,5MHz	L7 (Contrôle)	2,5V	(a)
2	BORD DE BANDE (2)	-	Relier un voltmètre CC entre les TP5 (VT) et TP6 (GND).	108,0MHz	TC1 (Contrôle)	8,0V	(a)
Répéter les points 1 et 2 plusieurs fois.							
3	ALIGNEMENT HT	(A) 98,0MHz 1kHz. ±75kHz dév	(B)	MONO 98,0MHz	L2,3,5* (Contrôle)	Amplitude et symétrie maximale de l'affichage de l'oscilloscope.	
4	DISCRIMINATEUR	(A) 98,0MHz 1kHz. ±75kHz dév 60dBμ(Entrée ANT)	Relier un voltmètre CC entre les TP7 et TP8.	MONO 98,0MHz	L8	0V	(b)
5	VCO	(A) 98,0MHz 0 dév 60dBμ(Entrée ANT)	Relier une résistance de 330kΩ à TP11. Raccorder un compteur de fréquence à une résistance par l'intermédiaire d'un voltmètre CA.	98,0MHz	VR3	19,00kHz	(c)
6	DISTORSION (STEREO)	(C) 98,0MHz 1kHz. ±68,25kHz dév Selection: L ou R 60dBμ(Entrée ANT)	(B)	98,0MHz	L6 (Contrôle)	Distorsion minimale. (L ou R)	
7	NIVEAU D'ACCORDER	(A) 98,0MHz 0 dév 18dBμ(Entrée ANT)		98,0MHz	VR2	Ajuster VR2 que FL1(TUNED) est non allumé. Alors, ajuster VR2 et arrêter le mouvement de VR1 au moment où le FL1(TUNED) s'allume.	
SECTION MA Laisser l'antenne bouche MA installée. SELECTEUR: AM(T-93) ou MW(T-93L)							
(1)	BORD DE BANDE (1)		Relier un voltmètre CC entre les TP5 (VT) et TP6 (GND).	530kHz (531kHz)	L5	1,5V	(a)
(2)	BORD DE BANDE (2)		Relier un voltmètre CC entre les TP5 (VT) et TP6 (GND).	1610kHz (1602kHz)	TC4	8,0V	(a)
Répéter les points (1) et (2) plusieurs fois.							
(3)	ALIGNEMENT HT (1)	(D) 630kHz 400Hz. 30% mod	(B)	630kHz	L3	Amplitude et symétrie maximale de l'affichage de l'oscilloscope.	
(4)	ALIGNEMENT HT (2)	(D) 1440kHz 400Hz. 30% mod	(B)	1440kHz	TC2	Amplitude et symétrie maximale de l'affichage de l'oscilloscope.	
Répéter les points (3) et (4) plusieurs fois.							
SECTION GO(T-93L seulement) Laisser l'antenne bouche MA installée. SELECTEUR: LW							
(5)	BORD DE BANDE (1)		Relier un voltmètre CC entre les TP5 (VT) et TP6 (GND).	153kHz	L4	1,5V	(a)
(6)	BORD DE BANDE (2)		Relier un voltmètre CC entre les TP5 (VT) et TP6 (GND).	281kHz	TC3	8,0V	(a)
Répéter les points (5) et (6) plusieurs fois.							
(7)	ALIGNEMENT HT (1)	(D) 162kHz 400Hz. 30% mod	(B)	162kHz	L2	Amplitude et symétrie maximale de l'affichage de l'oscilloscope.	
(8)	ALIGNEMENT HT (2)	(D) 270kHz 400Hz. 30% mod	(B)	270kHz	TC1	Amplitude et symétrie maximale de l'affichage de l'oscilloscope.	
Répéter les point (7) et (8) plusieurs fois.							

* L5: T-93L seulement

ABGLEICH

NR.	GEGENSTAND	EINGANGS-EINSTELLUNG	AUSGANGS-EINSTELLUNG	TUNER-EINSTELLUNG	ABGLEICH-PUNKTE	ABGLEICHEN FÜR	ABB.
UKW - EMPFANGSABTEILUNG Außer wenn anders angegeben, die verschiedenen Schalter wie folgt einstellen: SELECTOR: FM MODE: FM MODE/MUTING ON							
1	BANDKANTE (1)	-	Einen Gleichspannungsmesser zwischen TP5 (VT) und TP6 (GND) anschließen.	87,5MHz	L7 (Eingangsstufe)	2,5V	(a)
2	BANDKANTE (2)	-	Einen Gleichspannungsmesser zwischen TP5 (VT) und TP6 (GND) anschließen.	108,0MHz	TC1 (Eingangsstufe)	8,0V	(a)
Abstimmungen 1 und 2 mehrere Male wiederholen.							
3	EMPFANGSBEREICH-ABSTIMMUNGEN	(A) 98,0MHz 1kHz. ±75kHz Hub	(B)	MONO 98,0MHz	L2,3,5* (Eingangsstufe)	Maximal Amplitude und Symmetrie des Oszilloskopbildes.	
4	DISKRIMINATOR	(A) 98,0MHz 1kHz. ±75kHz Hub 60dBμ(ANT Eingang)	Einen Gleichspannungsmesser zwischen TP8 und TP7 anschließen.	MONO 98,0MHz	L8	0V	(b)
5	SPANNUNGS-GEREGELTER OSZILLATOR	(A) 98,0MHz 0 Hub 60dBμ(ANT Eingang)	Einen 330kΩ Widerstand zu TP11 anschließen. Einen Frequenzzähler über einen Wechselspannungsmesser an den Widerstand anschließen.	98,0MHz	VR3	19,00kHz	(c)
6	KLIRRFaktor (STEREO)	(C) 98,0MHz 1kHz. ±68,25kHz Hub Wähler: L oder R 60dBμ(ANT-Eingang)	(B)	98,0MHz	L6 (Eingangsstufe)	Minimal Klirrfactor. (L oder R)	
7	ABSTIMM PEGEL	(A) 98,0MHz 0 Hub 18dBμ(ANT-Eingang)		98,0MHz	VR2	Den Pegel widerstand VR2 so einstellen, daß der FL1(TUNED)anzeiger nicht leuchtet. Dann der Pegel widerstand aufdrehen. und dem VR2 Halt geben wobei den FL1(TUNED) anzeiger leuchtet wird.	
MW - EMPFANGSABTEILUNG Die MW-Rahmenantenne angebracht lassen. SELECTOR: AM(T-93) oder MW(T-93L)							
(1)	BANDKANTE (1)	-	Einen Gleichspannungsmesser zwischen TP5 (VT) und TP6 (GND) anschließen.	530kHz (531kHz)	L5	1,5V	(a)
(2)	BANDKANTE (2)	-	Einen Gleichspannungsmesser zwischen TP5 (VT) und TP6 (GND) anschließen.	1610kHz (1602kHz)	TC4	8,0V	(a)
Abstimmungen (1) und (2) mehrere Male wiederholen.							
(3)	HF-ABGLEICH (1)	(D) 630kHz 400Hz. 30% mod	(B)	630kHz	L3	Maximal Amplitude und Symmetrie des Oszilloskopbildes.	
(4)	HF-ABGLEICH (2)	(D) 1440kHz 400Hz. 30% mod	(B)	1440kHz	TC2	Maximal Amplitude und Symmetrie des Oszilloskopbildes.	
Abstimmungen (3) und (4) mehrere Male wiederholen.							
LW - EMPFANGSABTEILUNG (nur T-93L) Die MW-Rahmenantenne angebracht lassen. SELECTOR: LW							
(5)	BANDKANTE (1)	-	Einen Gleichspannungsmesser zwischen TP5 (VT) und TP6 (GND) anschließen.	153kHz	L4	1,5V	(a)
(6)	BANDKANTE (2)	-	Einen Gleichspannungsmesser zwischen TP5 (VT) und TP6 (GND) anschließen.	281kHz	TC3	8,0V	(a)
Abstimmungen (5) und (6) mehrere Male wiederholen.							
(7)	HF-ABGLEICH (1)	(D) 162kHz 400Hz. 30% mod	(B)	162kHz	L2	Maximal Amplitude und Symmetrie des Oszilloskopbildes.	
(8)	HF-ABGLEICH (2)	(D) 270kHz 400Hz. 30% mod	(B)	270kHz	TC1	Maximal Amplitude und Symmetrie des Oszilloskopbildes.	
Abstimmungen (7) und (8) mehrere Male wiederholen.							

* L5: nur T-93L

T-93/93L

ADJUSTMENT/REGLAGES/ARGLEICH

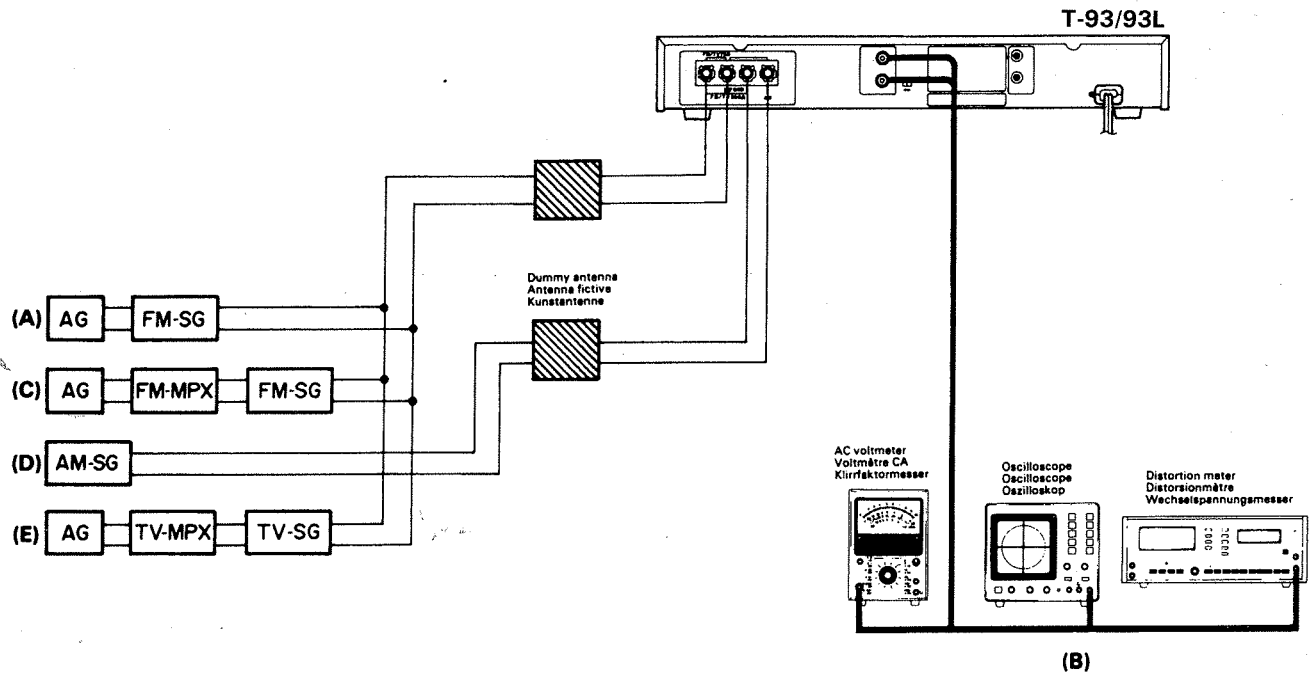

VOLTAGE TABLES

TUNER UNIT (X05-378X-XX)

IC1

1	1.1V
2	1.6V
3-6	0V
7	12.4V
8	12.5V
9	0.2V
10	0.06V
11	2.7V
12, 13	5.0V
14	1.1V
15	0.9V
16	0V

IC2

1-3	2.2V
4	0V
5-7	10.4V
8	0.02V
9	3.7V
10	3.0V
11, 12	1.4V
13, 14	0V
15	2.2V
16	1.4V
17	0V
18, 19	0.05V
20	3.8V
21	2.2V
22	1.2V

IC3

1	10.7V
2	2.5V
3	5.9V
4, 5	8.5V
6, 7	3.8V
8	0V
9	0.9V
10-14	2.5V
15	3.2V
16	0V

X05-378X-XX

Q1

E	1.2V
C	10.6V
B	1.9V

Q2

E	0V
C	2.5V
B	0.6V

Q3

E	0.6V
C	2.5V
B	1.1V

Q4 (T-93L only)

G	5.1V
D	2.5V
S	2.5V

Q6 (T-93L only)

E	0V
C	12.4V
B	0V

Q7 (T-93L only)

E	0V
C	12.5V
B	0V

Q8 (T-93L only)

E	0V
C	12.5V
B	0.07V

Q11 (T-93 only)

E	-
C	12.5V
B	3.0V

Q13

E	12.5V
C	12.3V
B	11.7V

Q15

E	3.5V
C	-1.4V
B	4.9V

Q16

E	5.5V
C	10.2V
B	6.1V

Q17, 18

E	0V
C	0V
B	-1.4V

Q21

E	12.5V
C	16.5V
B	13.1V

Q22

E	16.5V
C	16.5V
B	15.8V

Q23

E	0V
C	0.01V
B	0.6V

Q24

E	12.5V
C	0.06V
B	12.5V

Q25 (T-93L only)

E	12.5V
C	0V
B	12.5V

DISPLAY UNIT X14-262X-XX JAPAN MADE X14-263X-XX SINGAPORE MADE

Q1

E	-27.9V
C	5.7V
B	-27.9V

Q2

E	-27.9V
C	5.7V
B	-27.9V

Q3

E	
C	
B	

Q4

E	5.7V
C	5.6V
B	4.9V

Q5

E	0V
C	4.9V
B	0V

FM-FRONT END UNIT X86-1052-70 (T-93L), X86-1040-10 (T-93) JAPAN MADE X86-1122-70 (T-93L), X86-1130-10 (T-93) SINGAPORE MADE

Q1

G	-
D	9V
S	-

Q2

G1	-
G2	-
D	11.5V
S	-

Q3 (T-93L only)

G	-
D	7V
S	-

Q4

E	5V
C	11.5V
B	-

Q5

E	-
C	-
B	-

PC BOARD (Component side view) (T-93)

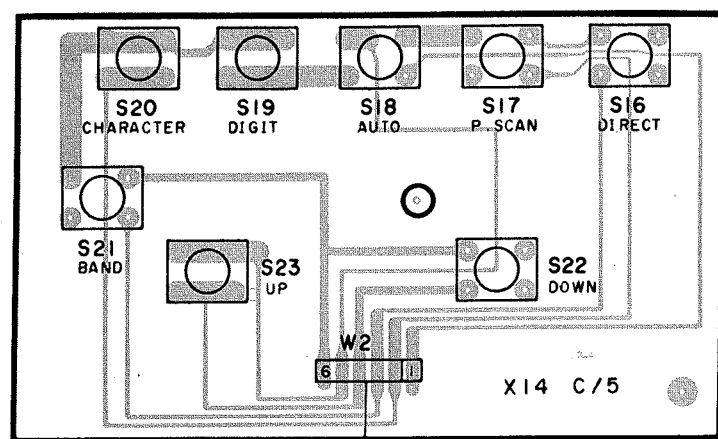

DISPLAY UNIT
 (X14-2620-21) (Japan made)
 (X14-2630-20) (Singapore made)

DISPLAY UNIT
 (X14-2620-21) (Japan made)
 (X14-2630-20) (Singapore made)

Ref. No.	IC	Q	Address
		1	1I
		2	2I
		3	5F
		4	3I
		5	2I
1			2H

FRONT END UNIT
 (X86-1040-10) (Japan made)
 (X86-1130-10) (Singapore made)

Ref. No.	IC	Q	Address
		1	5K
		2	4K
		4	4K
		5	4J

TUNER UNIT
 (X05-378X-XX)

Ref. No.	IC	Q	Address
		1	5N
		2	3L
		3	4L
		4	-
		6	-
		7	-
		8	-
		11	-
		13	4N
		15	6Q
		16	3O
		17	6Q
		18	6Q
		19	6R
		20	5R
		21	4P
		22	4P
		23	4O
		24	4M
		25	-
1			3M
2			5P
3			3Q

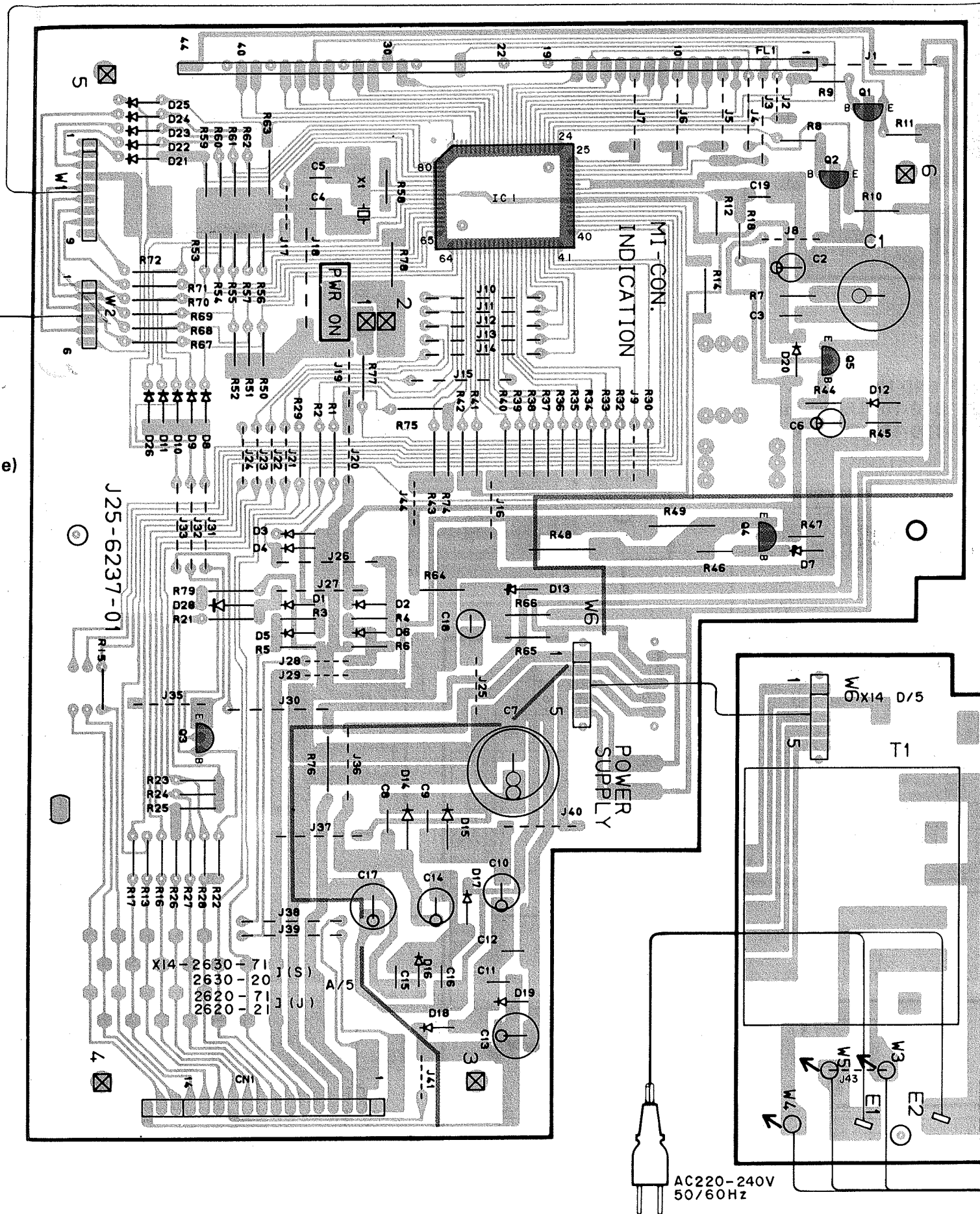

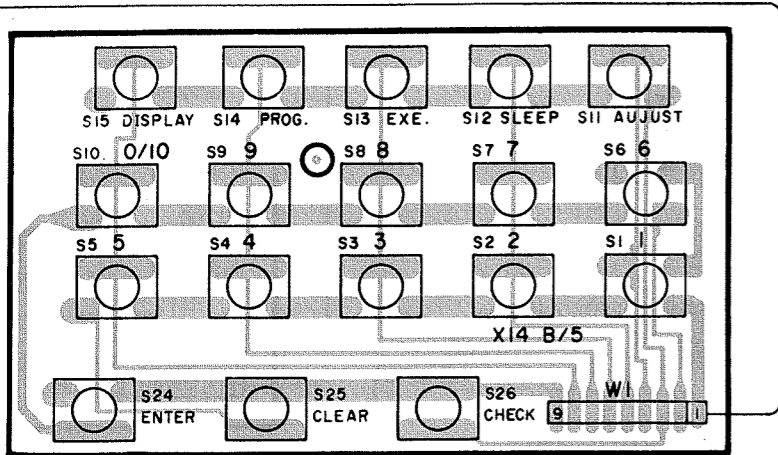

FRONT ↑

(a) BAND EDGE

DC voltmeter	FM1	2.5 V
	FM2	8.0 V
	AM1	1.5 V
	AM2	8.0 V

(b) DISCRIMINATOR
0 V
DC voltmeter

(c) VCO
19.00 kHz
Frequency counter

TUNER UNIT (X05-378X-XX)

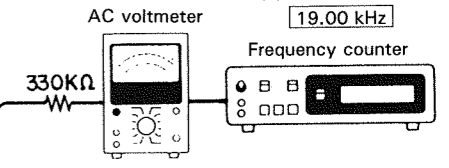

FRONT END UNIT
(X86-1040-10) (Japan made)
(X86-1130-10) (Singapore made)
X86-1040-10(J)
1130-10(S)

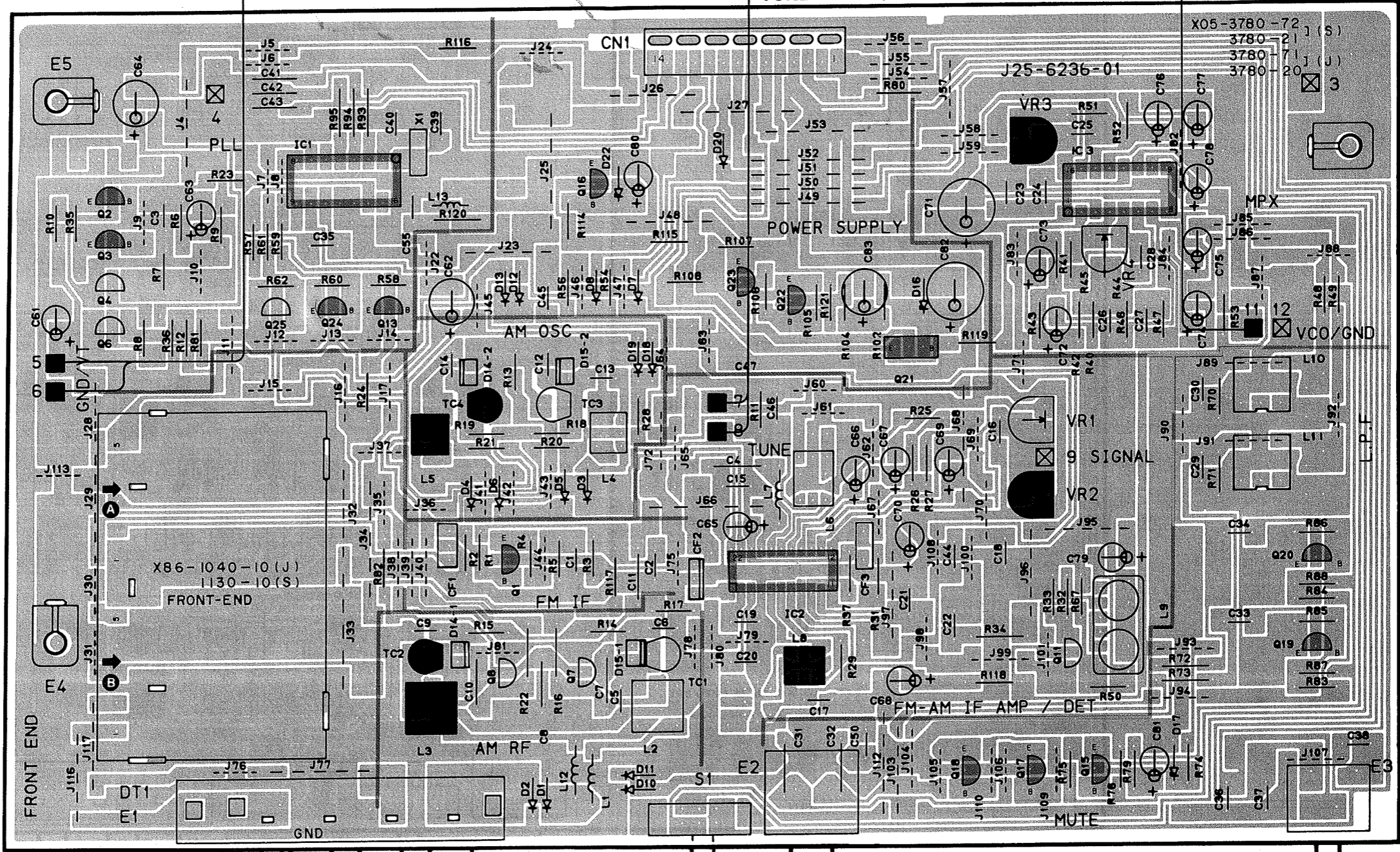
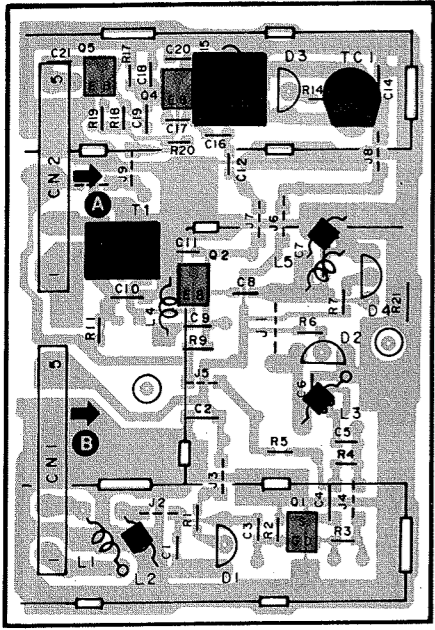

X14-2630-20(S)
2620-21(J) E/5

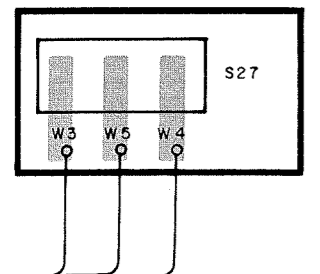

FM 75Ω FM 300Ω AM EMPHISIS & CH SPACE OUTPUT

SYSTEM CONTROL T-93(M)

Refer to the schematic diagram for the values of resistors and capacitors.

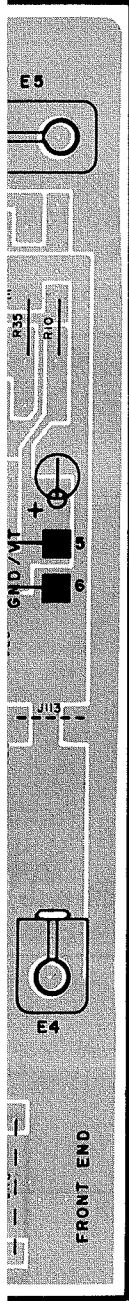
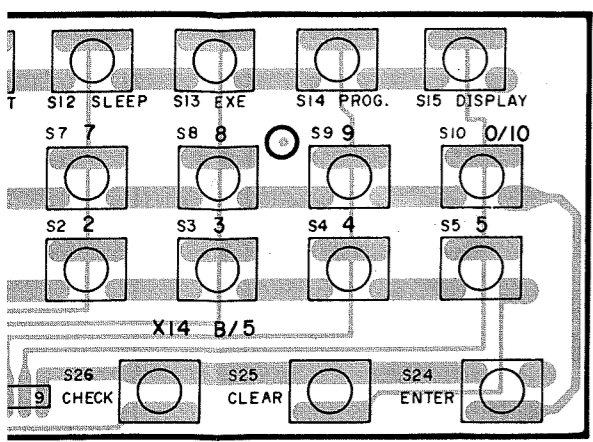

FRONT END UNIT
 (X86-1040-10) (Japan made)
 (X86-1130-10) (Singapore made)

X86-1040-10 (J)
 1130-10 (S)

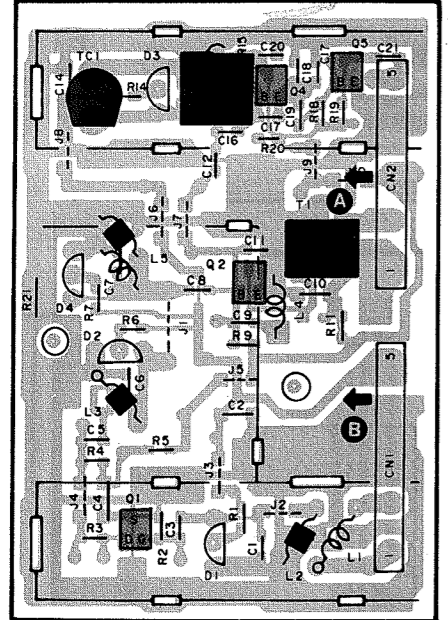

X14-2630-20 (S)
 2620-21 (J) E/5

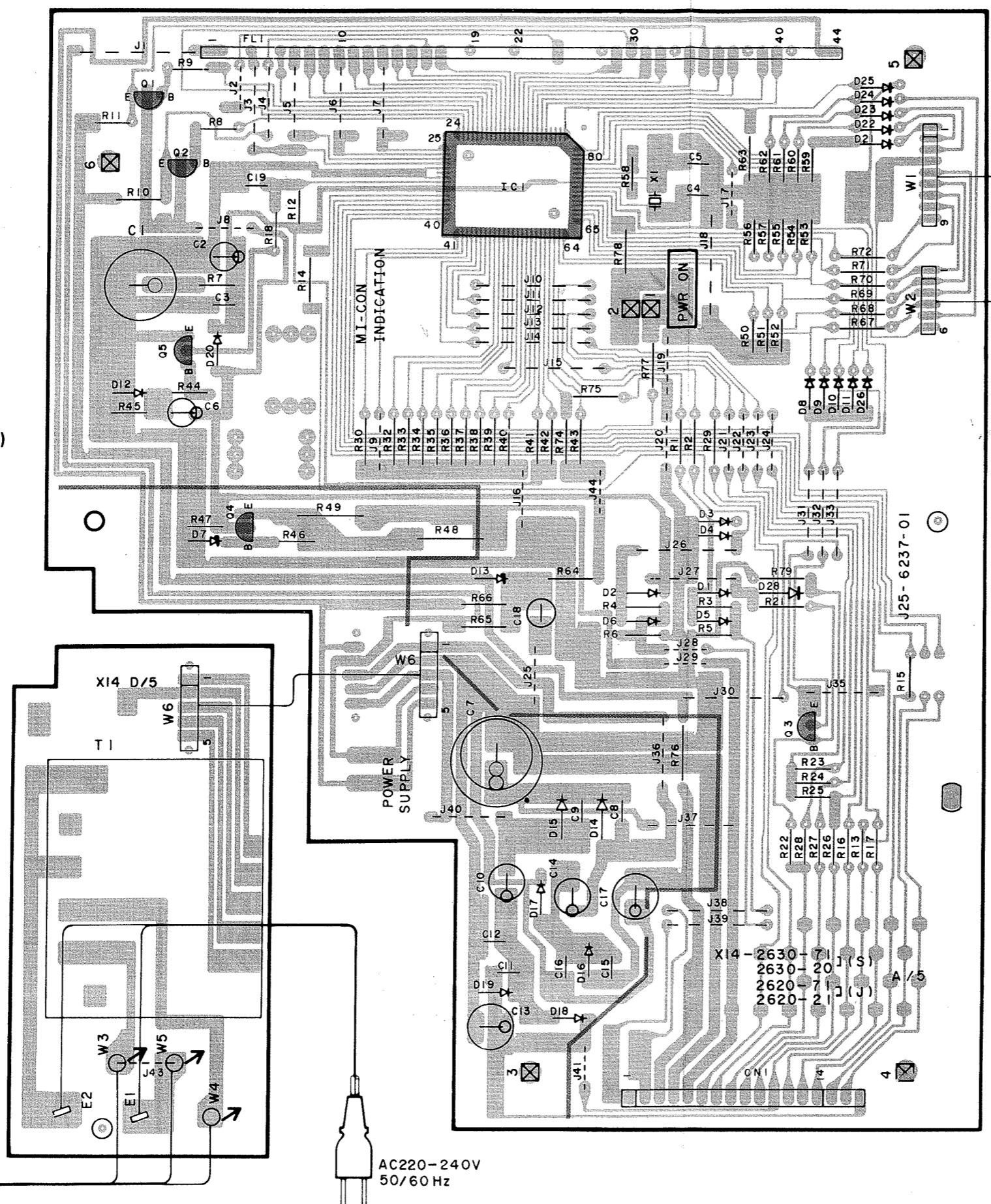
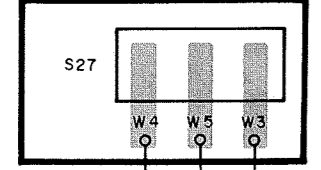

AC220-240V
 50/60 Hz

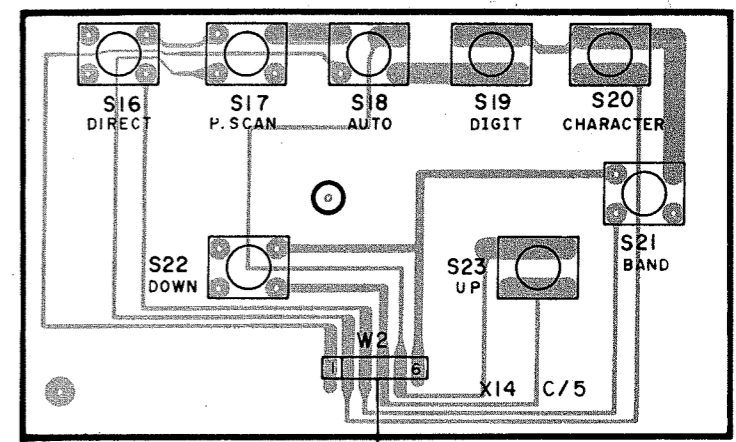

DISPLAY UNIT
 (X14-2620-21) (Japan made)
 (X14-2630-20) (Singapore made)

DISPLAY UNIT
 (X14-2620-21) (Japan made)
 (X14-2630-20) (Singapore made)

Ref. No.	IC	Q	Address
1		1	1AE
2		2	2AE
3		3	4AH
4		4	3AF
5		5	2AE
1		1	2AG

FRONT END UNIT
 (X86-1040-10) (Japan made)
 (X86-1130-10) (Singapore made)

Ref. No.	IC	Q	Address
1		1	5AC
2		2	4AD
4		4	4AD
5		5	3AD

TUNER UNIT
 (X05-378X-XX)

Ref. No.	IC	Q	Address
1		1	5Z
2		2	3AB
3		3	3AB
4		4	-
6		6	-
7		7	-
8		8	-
11		11	-
13		13	4AA
15		15	6W
16		16	3Z
17		17	6W
18		18	6X
19		19	6V
20		20	5V
21		21	4X
22		22	4Y
23		23	4Y
24		24	4AA
25		25	-
1		1	3AA
2		2	5Y
3		3	3W

T-93 (M)

Refer to the schematic diagram for the values of resistors and capacitors.

PC BOARD (Foil side view) (T-93)

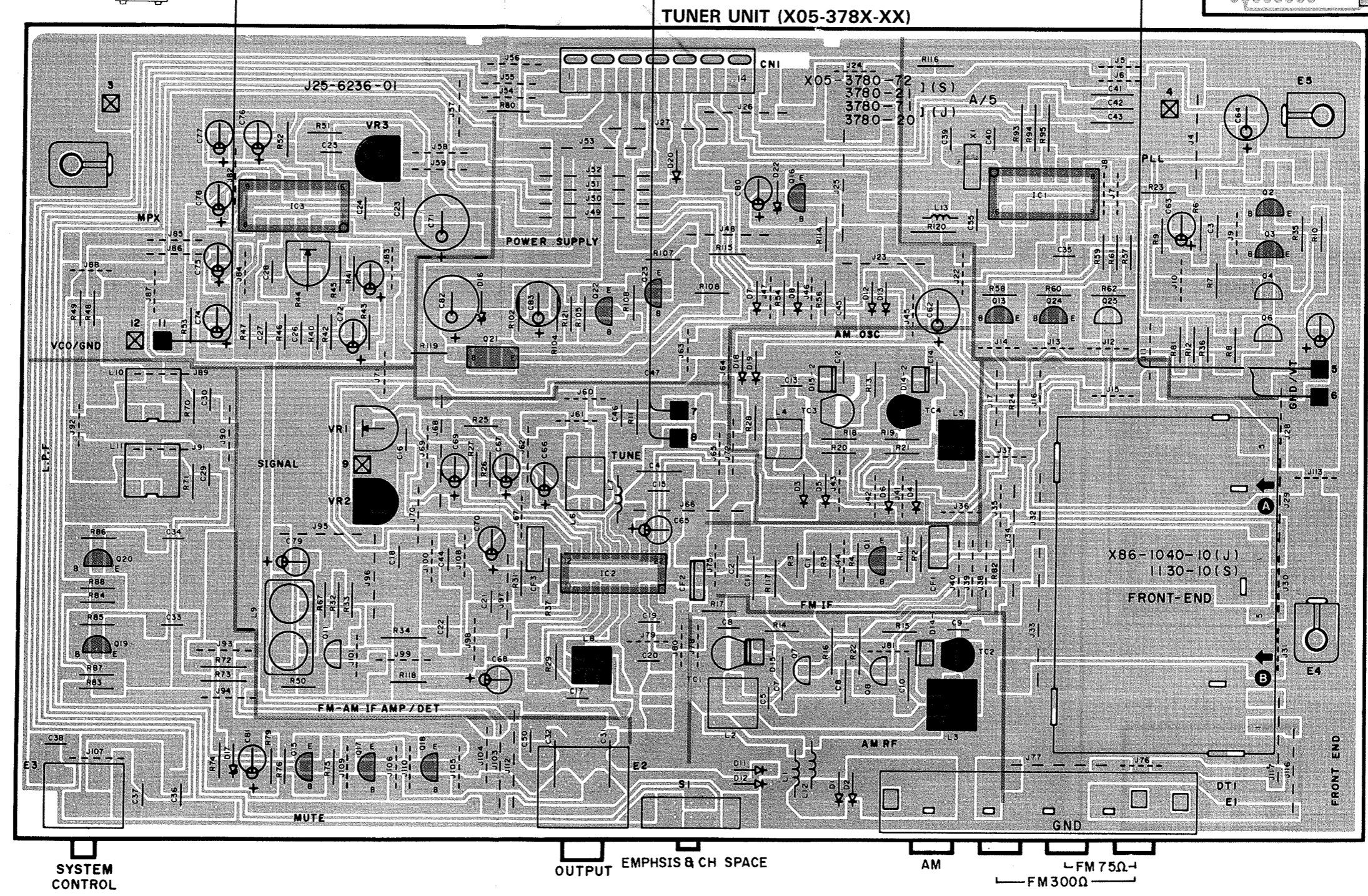
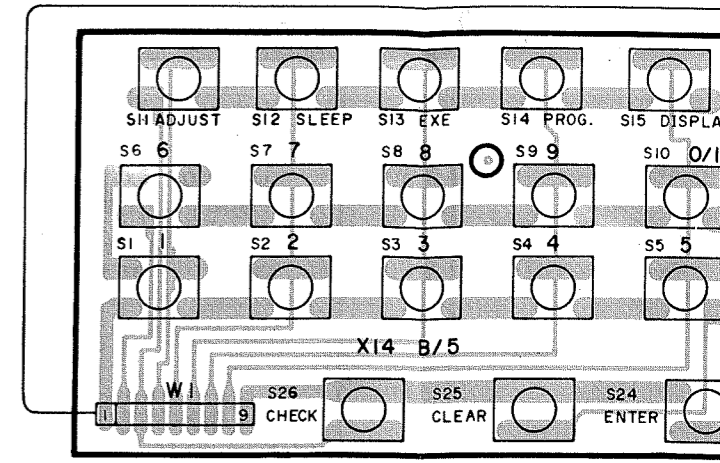
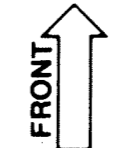
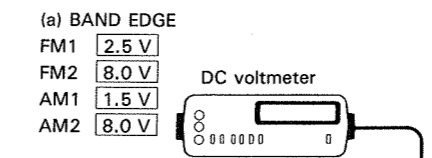
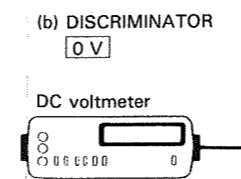
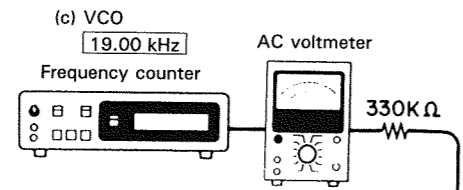

FRONT END UNIT
(X86-1040-10) (Japan m)
(X86-1130-10) (Singapore)
X86-1040-10 (J)
1130-10 (S)

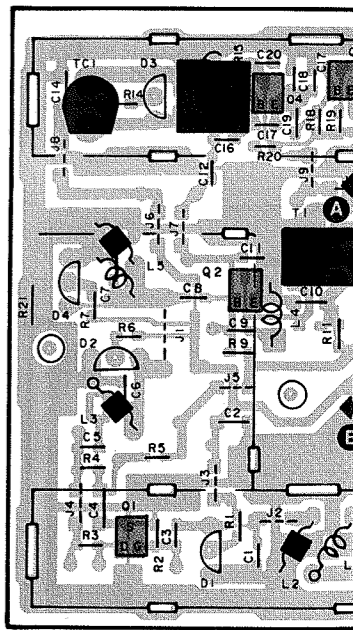

X14-2630-20 (S)
2620-21 (J) E/5

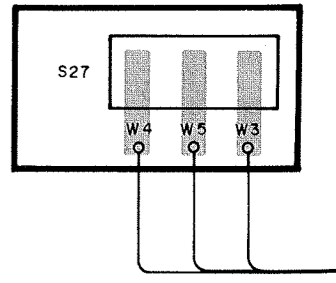

PC BOARD (Component side view) (T-93L)

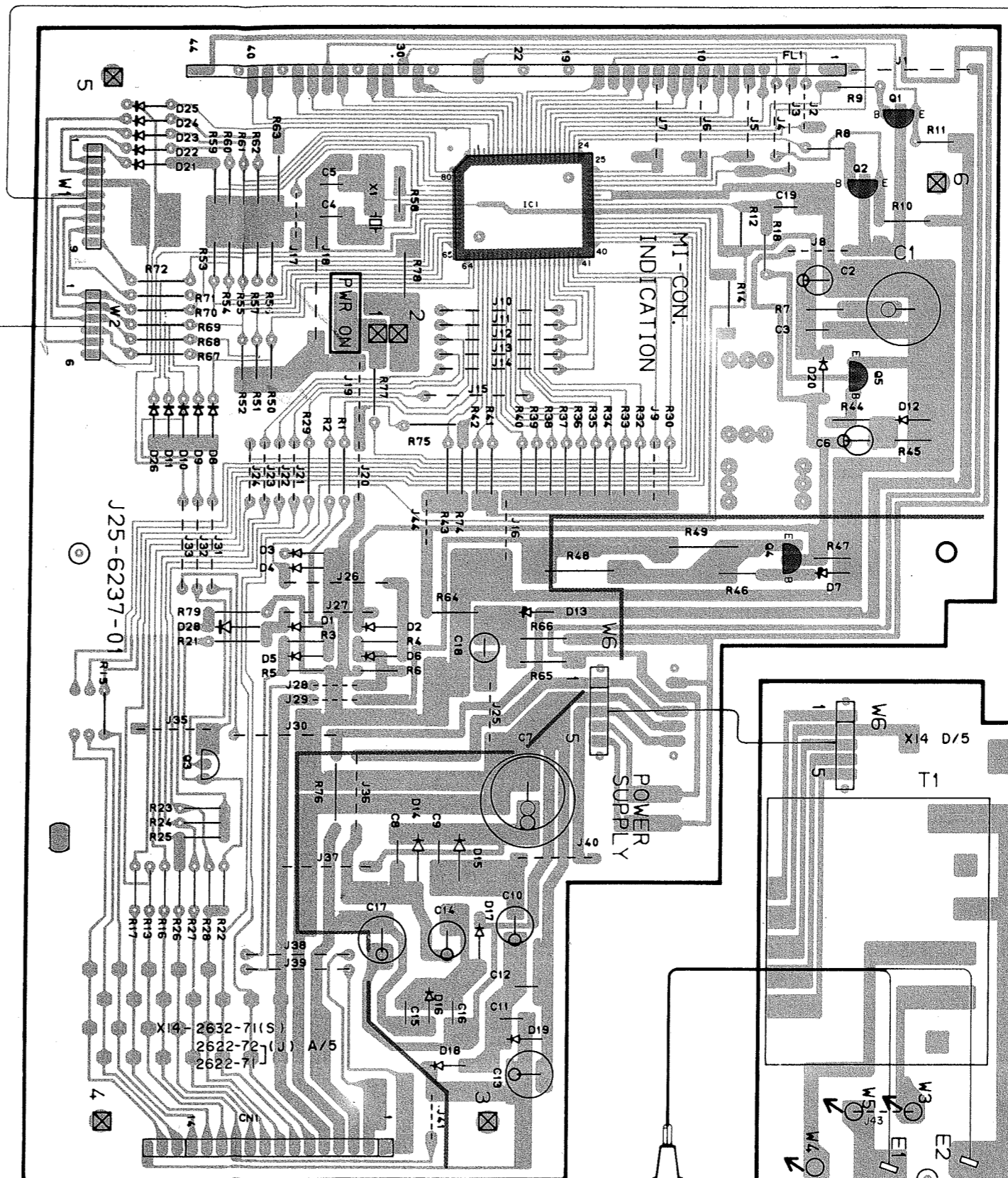
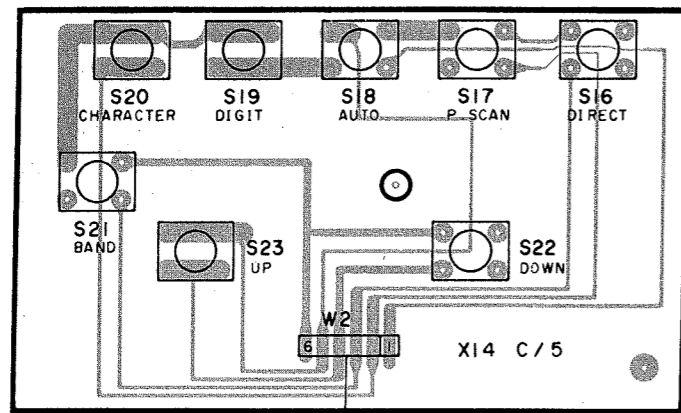

DISPLAY UNIT (X14-262X-XX) (Japan made)
(X14-263X-XX) (Singapore made)

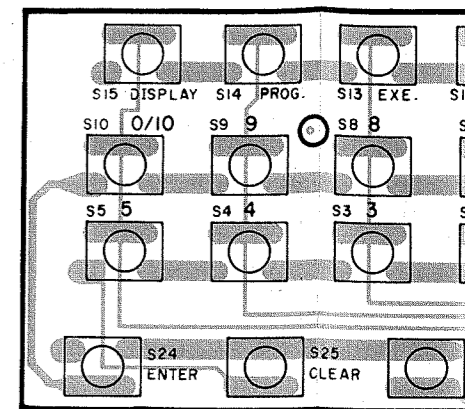

X86-1052-70(J)
1122-70(S)

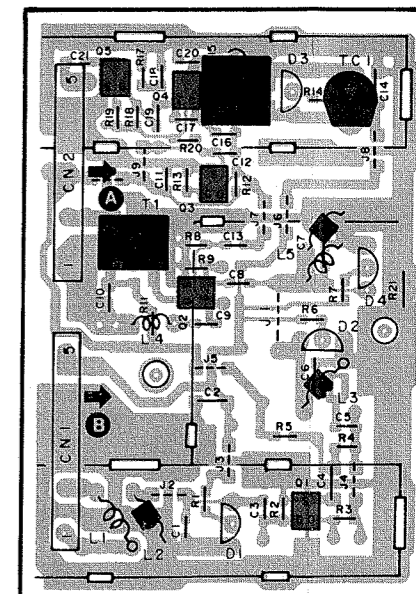

FRONT END UNIT
(X86-1052-70) (Japan made)
(X86-1122-70) (Singapore made)

AC220V
50Hz

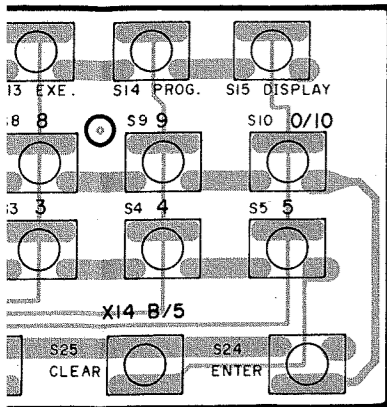

(86-1052-70 (J))
1122-70 (S)

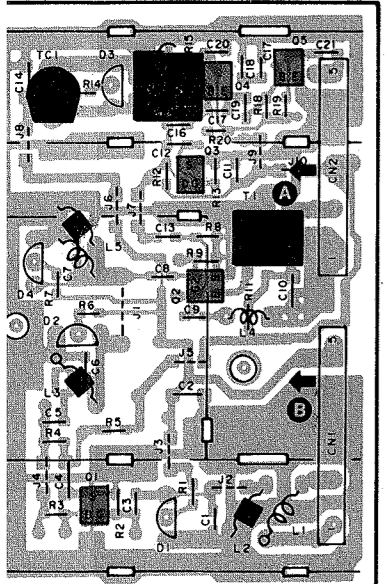

FRONT END UNIT
6-1052-70 (Japan made)
6-1122-70 (Singapore made)

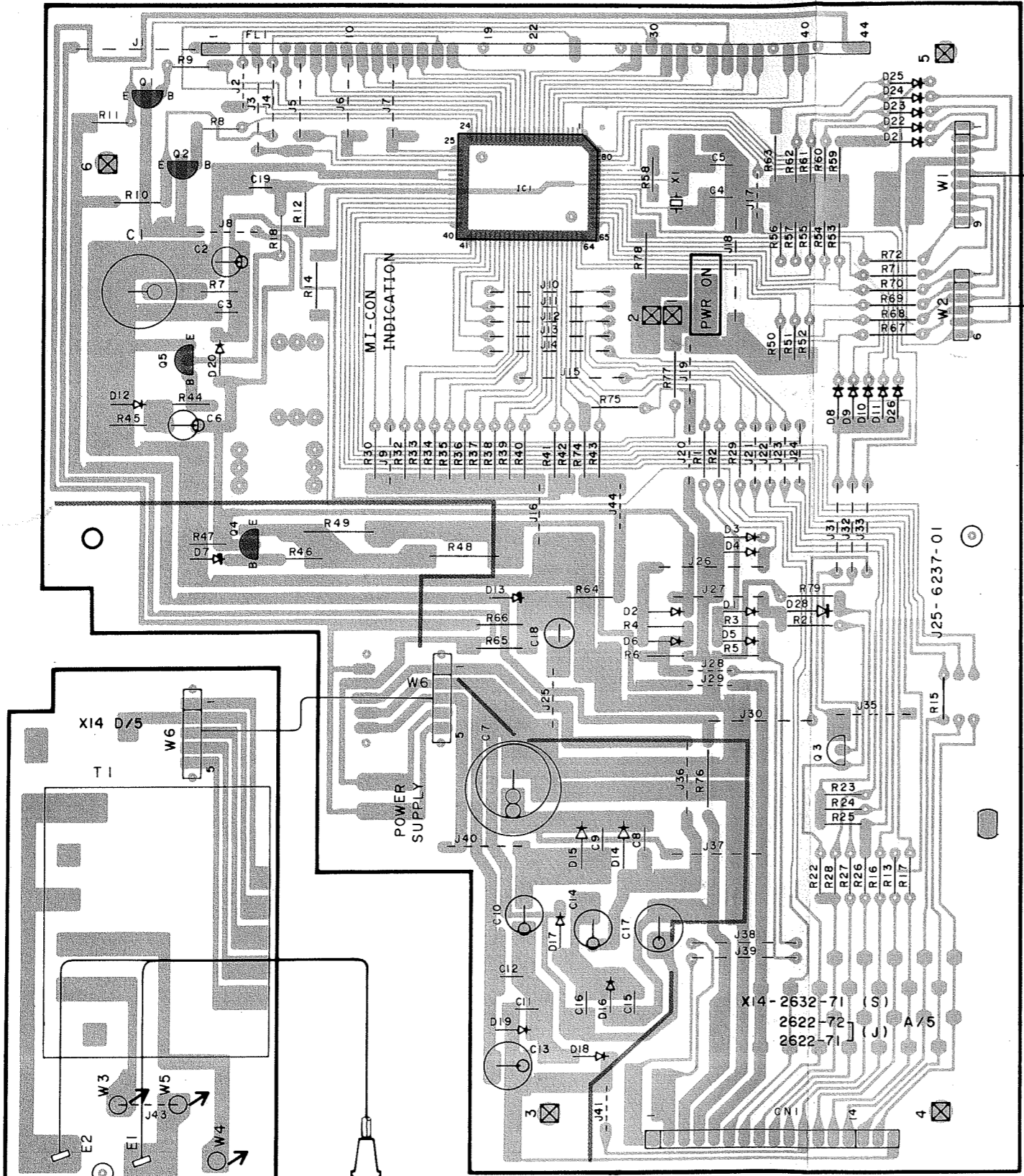

DISPLAY UNIT (X14-262X-XX) (Japan made)
(X14-263X-XX) (Singapore made)

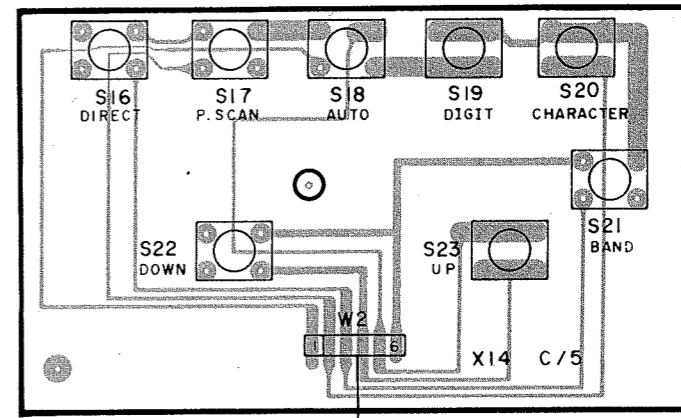

T-93L (E)

Refer to the schematic diagram for the values of resistors and capacitors.

PC BOARD (Foil side view) (T-93L)

TUNER UNIT (X05-378X-XX)

Ref. No.	IC	Q	Address
	1		5BL
	2		3BN
	3		4BN
	4		4BN
	6		4BN
	7		6BL
	8		6BL
	11		6BI
	13		4BM
	15		6BI
	16		3BL
	17		6BI
	18		6BJ
	19		6BH
	20		5BH
	21		4BJ
	22		4BK
	23		4BK
	24		4BM
	25		4BM
1			3BM
2			5BK
3			3BI

DISPLAY UNIT (X14-262X-XX) (Japan made) (X14-263X-XX) (Singapore made)

Ref. No.	IC	Q	Address
	1		1BQ
	2		2BQ
	3		4BT
	4		3BQ
	5		3BQ
1			2BR

FRONT END UNIT (X86-1052-70) (J) (X86-1122-70) (S)

Ref. No.	IC	Q	Address
	1		5BO
	2		4BO
	3		4BO
	4		4BO
	5		4BP

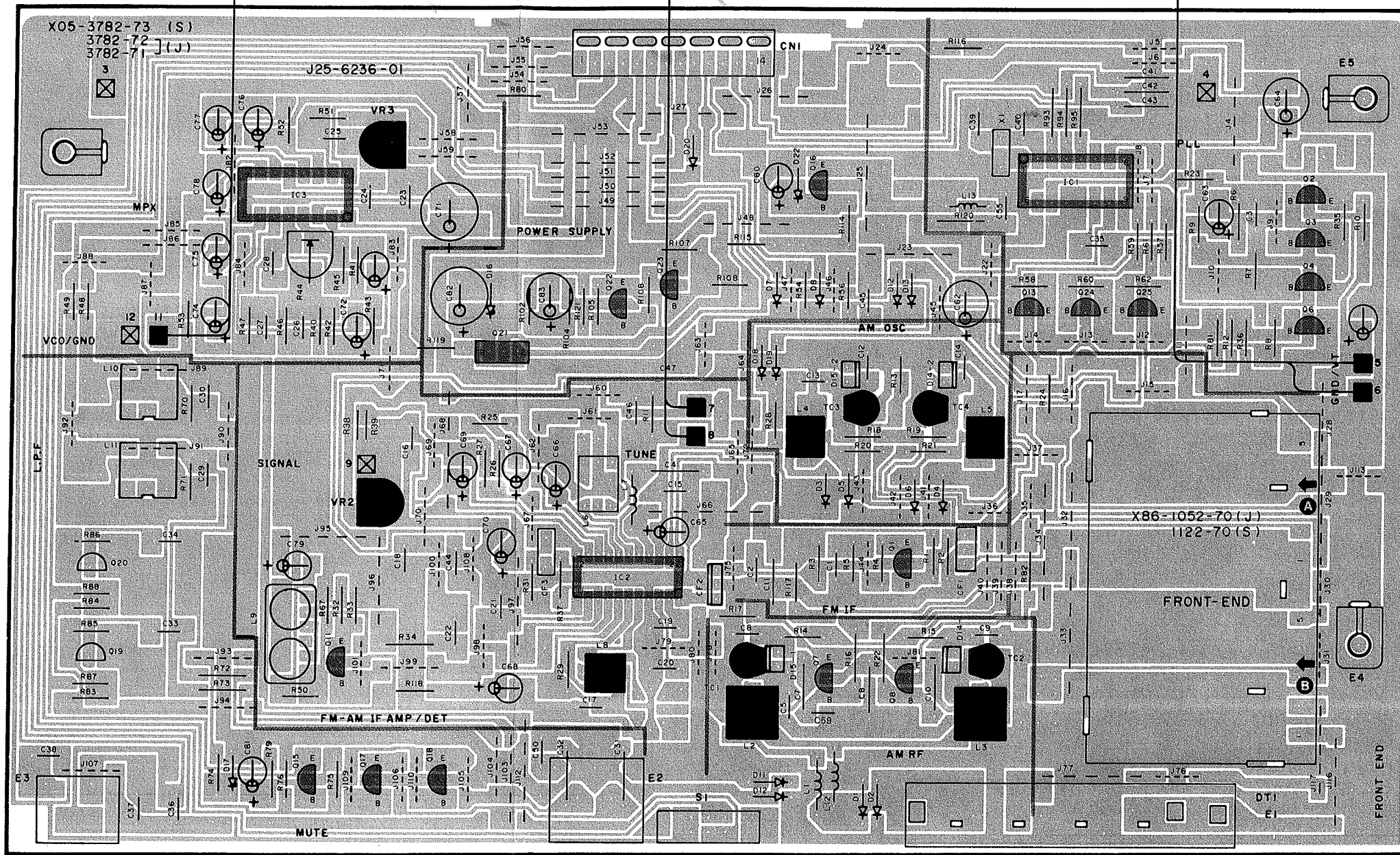
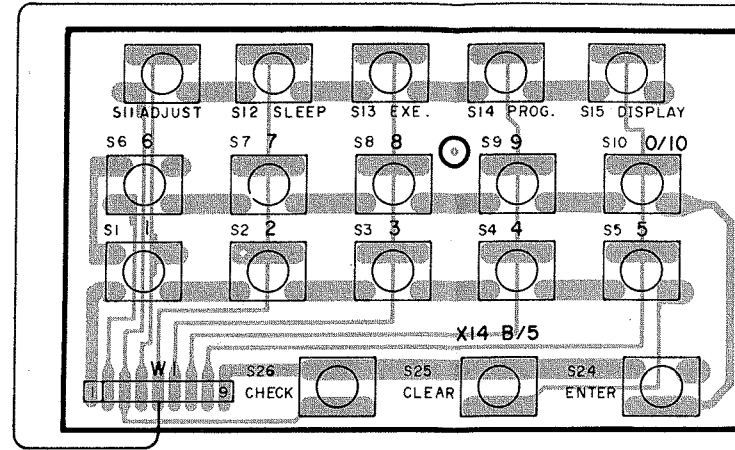
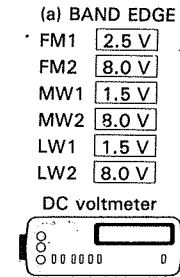
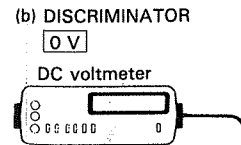
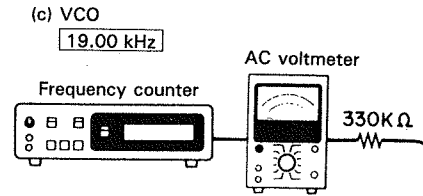

X86-1052-70 (J) 1122-70 (S)

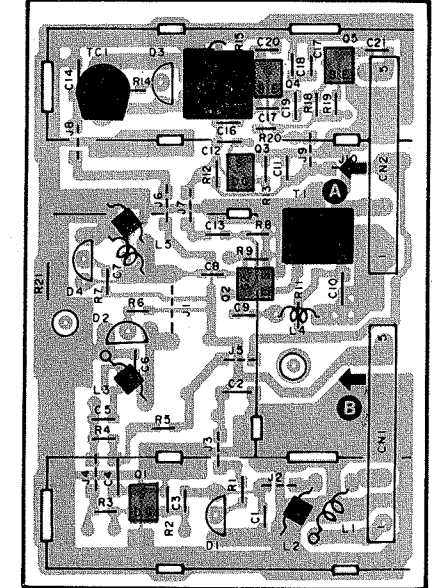

FRONT END UNIT (X86-1052-70) (Japan made) (X86-1122-70) (Singapore made)



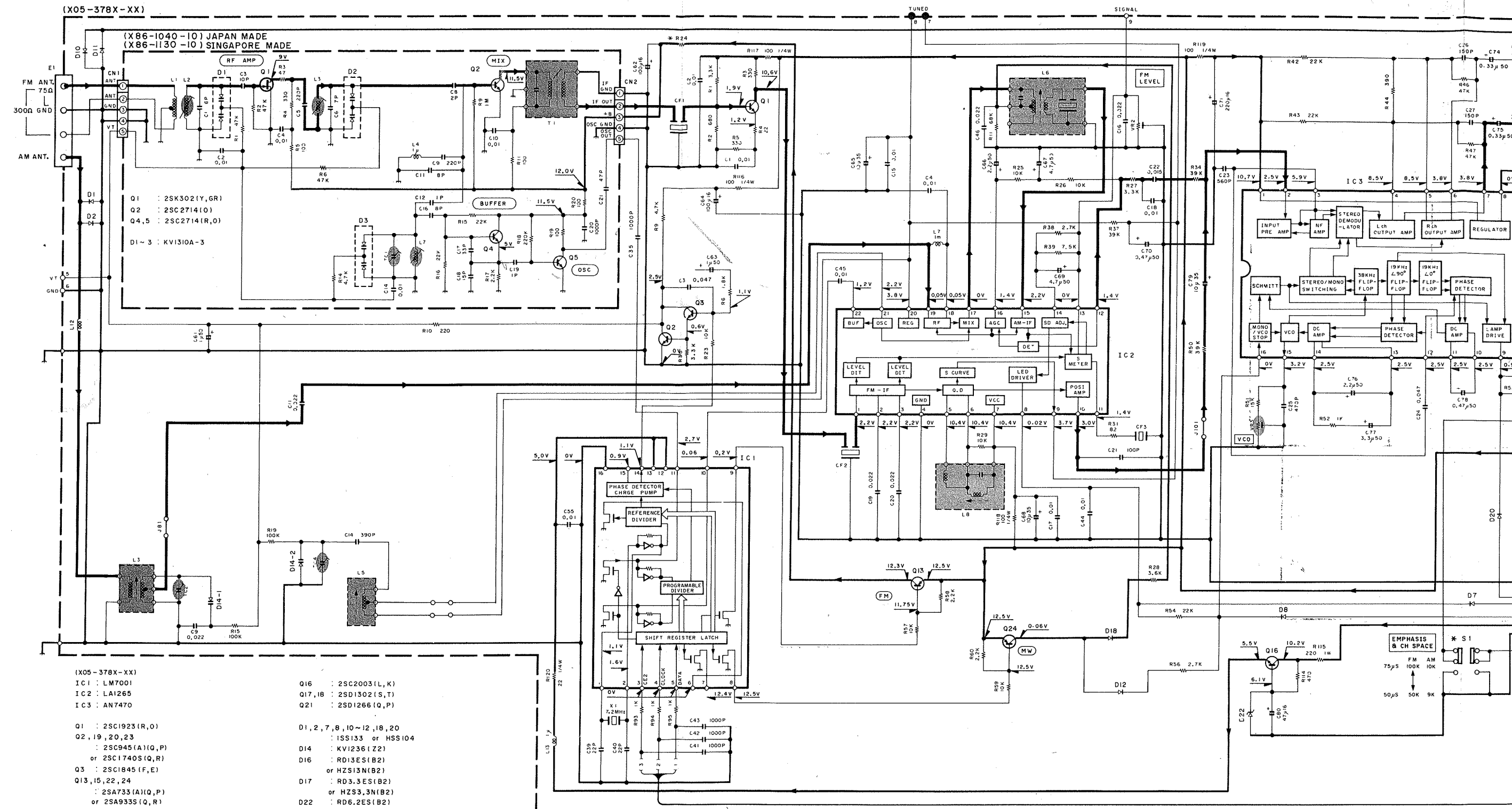

- (X05-378X-XX)
- IC 1 : LM7001
 IC 2 : LA1265
 IC 3 : AN7470
- Q1 : 2SC1923 (R, O)
 Q2, 19, 20, 23 : 2SC945 (A) (Q, P) or 2SC1740S (Q, R)
 Q3 : 2SC1845 (F, E)
 Q13, 15, 22, 24 : 2SA733 (A) (Q, P) or 2SA9335 (Q, R)
- Q16 : 2SC2003 (L, K)
 Q17, 18 : 2SD1302 (S, T)
 Q21 : 2SD1266 (Q, P)
- D1, 2, 7, 8, 10 ~ 12, 18, 20 : 1SS133 or HSS104
 D14 : KV1236 (Z2)
 D16 : RD13ES (B2) or HZS13N (B2)
 D17 : RD3.3ES (B2) or HZS3.3N (B2)
 D22 : RD6.2ES (B2) or HZS6.2N (B2)

(X05-378X-XX)

(X) TYPE	SINGAPORE MADE	JAPAN MADE	C33,34	R24	R83~88	Q19,20	S1
(X) TYPE	0-72	0-71	NO	47	NO	NO	NO
(M) TYPE	0-21	0-20	YES	56	YES	YES	YES

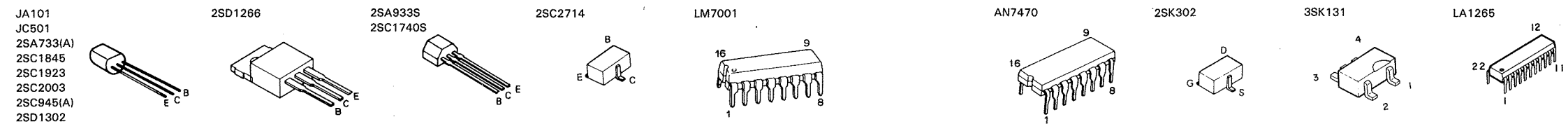

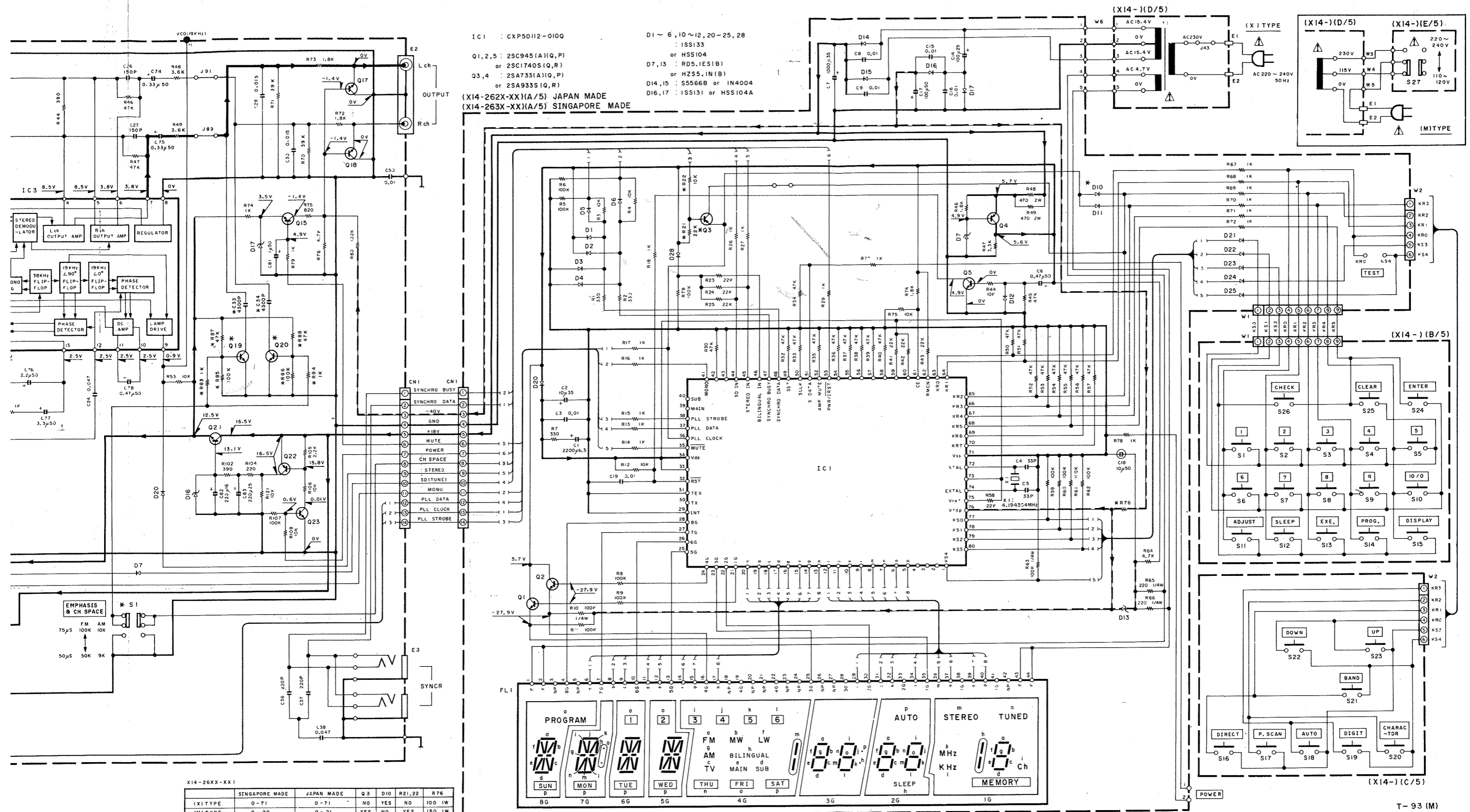

IC1 : CXPS0112-0100
 Q1,2,5 : 2SC945 (A)(Q,P)
 or 2SC1740S (Q,R)
 Q3,4 : 2SA733(A)(Q,P)
 or 2SA933S (Q,R)

D1 ~ 6, 10 ~ 12, 20 ~ 25, 28 : ISS133
 or HSS104
 D7, 13 : R05.1ES (B)
 or HZ55.1N (B)
 D14, 15 : S5566B or IN4004
 D16, 17 : ISS131 or HSS104A

(X14-262X-XX)(A/5) JAPAN MADE
 (X14-263X-XX)(A/5) SINGAPORE MADE

X14-26XX-XX1						
	SINGAPORE MADE	JAPAN MADE	Q3	D10	R21,22	R76
(X1)TYPE	0-71	0-71	NO	YES	NO	100 IW
(M1)TYPE	0-20	0-21	YES	NO	YES	150 IW

DC voltages are as measured with a high-impedance voltmeter during reception of the FM broadcast signal (with a signal strength of 60 dB at the ANT terminal). Values may vary slightly due to variations between individual instruments or/and units. Values in parentheses are as measured during reception of the AM broadcast signal (with a signal strength of 60 dB at the ANT terminal).

Les tensions c.c. doivent être mesurées avec un voltmètre à haute impédance pendant la réception d'un signal de programme FM (avec une force de signal de 60 dB à la borne ANT). Les valeurs peuvent différer légèrement du fait de variations inhérentes aux appareils et aux instruments de mesure individuels. Les valeurs entre parenthèses doivent être mesurées pendant la réception d'un signal de programme AM avec une force de signal de 60 dB à la borne ANT).

Die angegebenen Gleichspannungswerte wurden mit einem hochohmigen Spannungsmesser bei Empfang eines UKW-Signals (mit einer Feldstärke von 60 dB am Antennenanschluß) gemessen. Dabei schwanken die Meßwerte aufgrund von Unterschieden zwischen einzelnen Instrumenten oder Geräten u.U. geringfügig. Die eingeklammerten Gleichspannungswerte wurden bei Empfang eines MW-Signals (mit einer Feldstärke von 60 dB am Antennenanschluß) gemessen.

CAUTION: For continued safety, replace safety critical components only with manufacturer's recommended parts (refer to parts list). Indicates safety critical components. To reduce the risk of electric shock, leakage-current or resistance measurements shall be carried out (exposed parts are acceptably insulated from the supply circuit) before the appliance is returned to the customer.

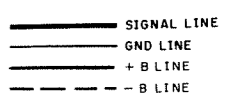

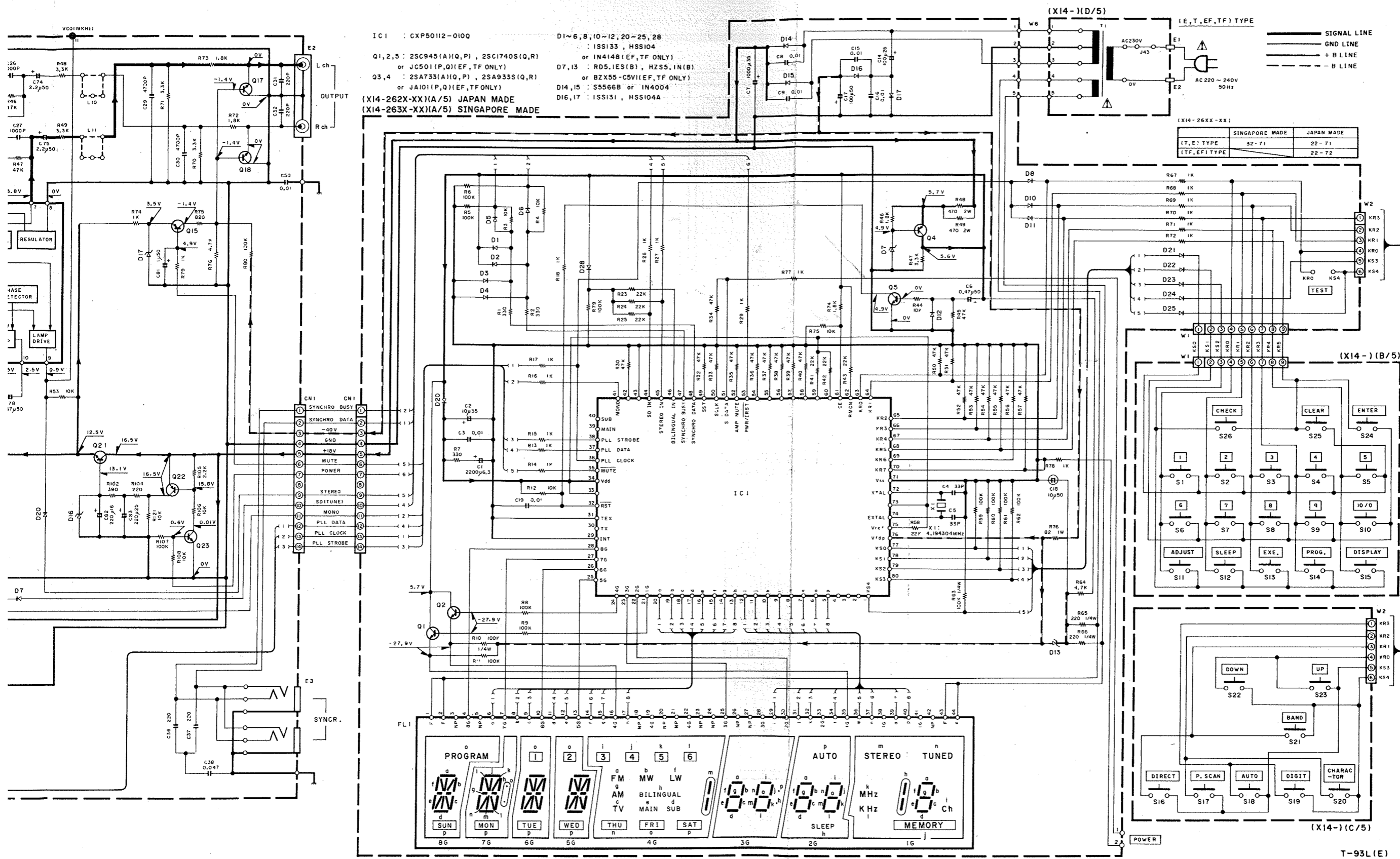

DC voltages are as measured with a high-impedance voltmeter during reception of the FM broadcast signal (with a signal strength of 60 dB at the ANT terminal). Values may vary slightly due to variations between individual instruments or/and units. Values in parentheses are as measured during reception of the AM broadcast signal (with a signal strength of 60 dB at the ANT terminal).

Les tensions c.c. doivent être mesurées avec un voltmètre à haute impédance pendant la réception d'un signal de programme FM (avec une force de signal de 60 dB à la borne ANT). Les valeurs peuvent différer légèrement du fait des variations inhérentes aux appareils et aux instruments de mesure individuels. Les valeurs entre parenthèses doivent être mesurées pendant la réception d'un signal de programme AM avec une force de signal de 60 dB à la borne ANT).

Die angegebenen Gleichspannungswerte wurden mit einem hochohmigen Spannungsmesser bei Empfang eines UKW-Signals (mit einer Feldstärke von 60 dB am Antennenanschluß) gemessen. Dabei schwanken die Meßwerte aufgrund von Unterschieden zwischen einzelnen Instrumenten oder Geräten u.U. geringfügig. Die eingeklammerten Gleichspannungswerte wurden bei Empfang eines MW-Signals (mit einer Feldstärke von 60 dB am Antennenanschluß) gemessen.

CAUTION: For continued safety, replace safety critical components only with manufacturer's recommended parts (refer to parts list). Indicates safety critical components. To reduce the risk of electric shock, leakage-current or resistance measurements shall be carried out (exposed parts are acceptably insulated from the supply circuit) before the appliance is returned to the customer.



(X05-378X-XX)

(X86-1052-70) JAPAN MADE
(X86-1122-70) SINGAPORE MADE

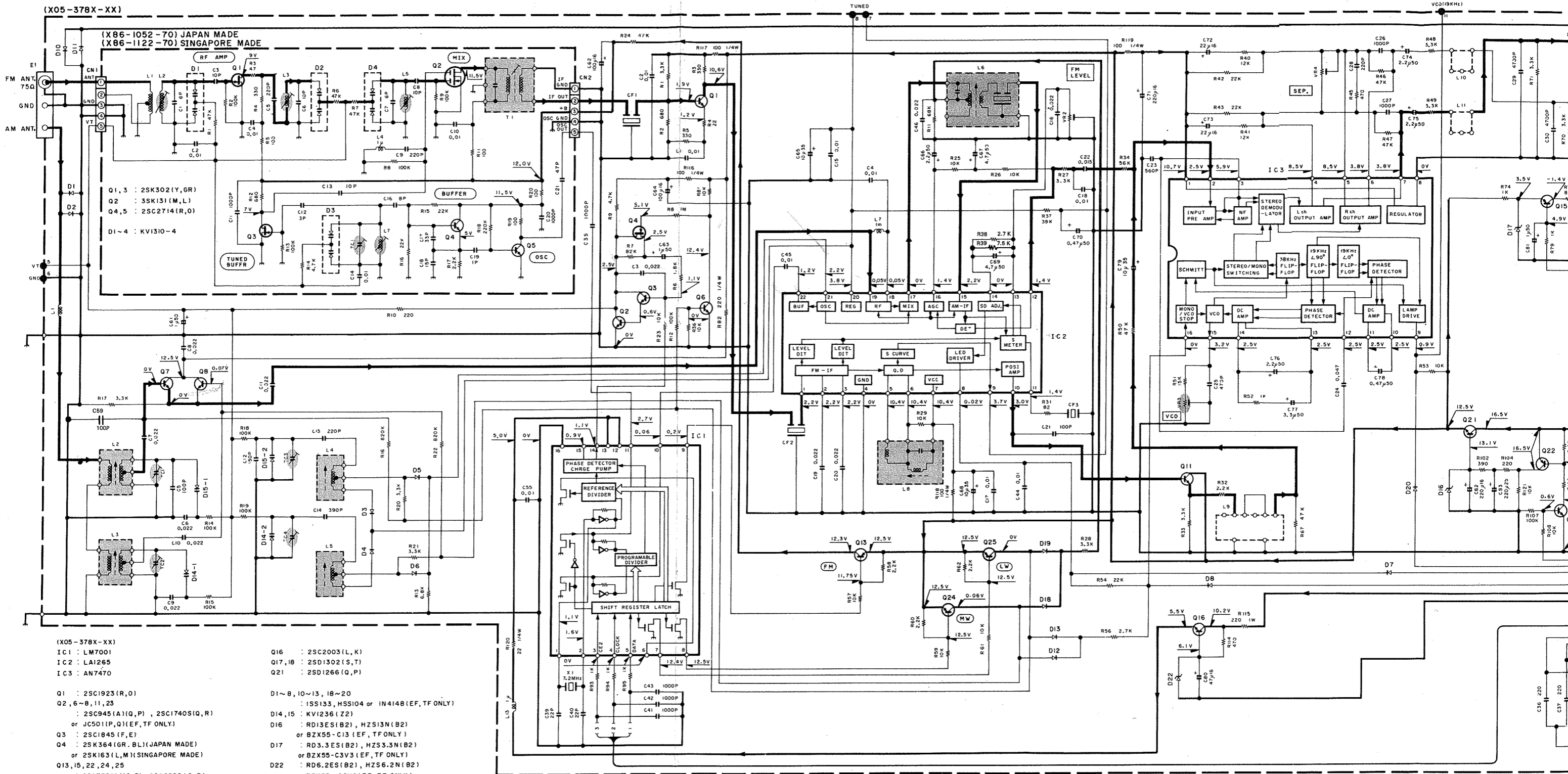

(X05-378X-XX)

IC1 : LM7001
IC2 : LA1265
IC3 : AN7470

Q1 : 2SC1923 (R, O)
 Q2, 6~8, 11, 23 : 2SC945 (A) (Q, P), 2SC1740S (Q, R) or JC501 (P, Q) (EF, TF ONLY)
 Q3 : 2SC1845 (F, E)
 Q4 : 2SK364 (GR. BL) (JAPAN MADE) or 2SK163 (L, M) (SINGAPORE MADE)
 Q13, 15, 22, 24, 25 : 2SA733 (A) (Q, P), 2SA933S (Q, R) or JA101 (P, Q) (EF, TF ONLY)

Q16 : 2SC2003 (L, K)
 Q17, 18 : 2SD1302 (S, T)
 Q21 : 2SD1266 (Q, P)
 D1~8, 10~13, 18~20 : 1SS133, HSS104 or IN4148 (EF, TF ONLY)
 D14, 15 : KV1236 (Z2)
 O16 : RD13ES (B2), HZS13N (B2) or BZX55-C13 (EF, TF ONLY)
 D17 : RD3.3ES (B2), HZS3.3N (B2) or BZX55-C3V3 (EF, TF ONLY)
 D22 : RD6.2ES (B2), HZS6.2N (B2) or BZX55-C6V2 (EF, TF ONLY)

(X05-378X-XX)		
	SINGAPORE MADE	JAPAN MADE
1E, T1 TYPE	2-73	2-71
1EF, TF TYPE		2-72

JA101
 JC501
 2SA733(A)
 2SC1845
 2SC1923
 2SC2003
 2SC945(A)
 2SD1302

2SD1266

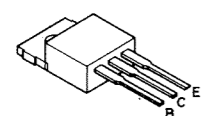

2SA933S
2SC1740S

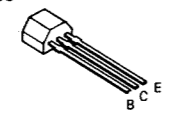

2SC2714

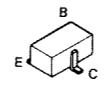

LM7001

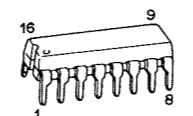

AN7470

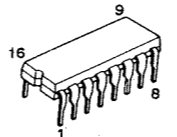

2SK163
2SK364

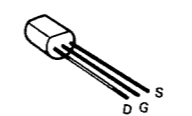

2SK302

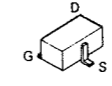

3SK131

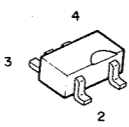

LA1265

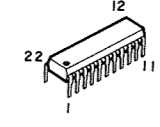

EXPLODED VIEW

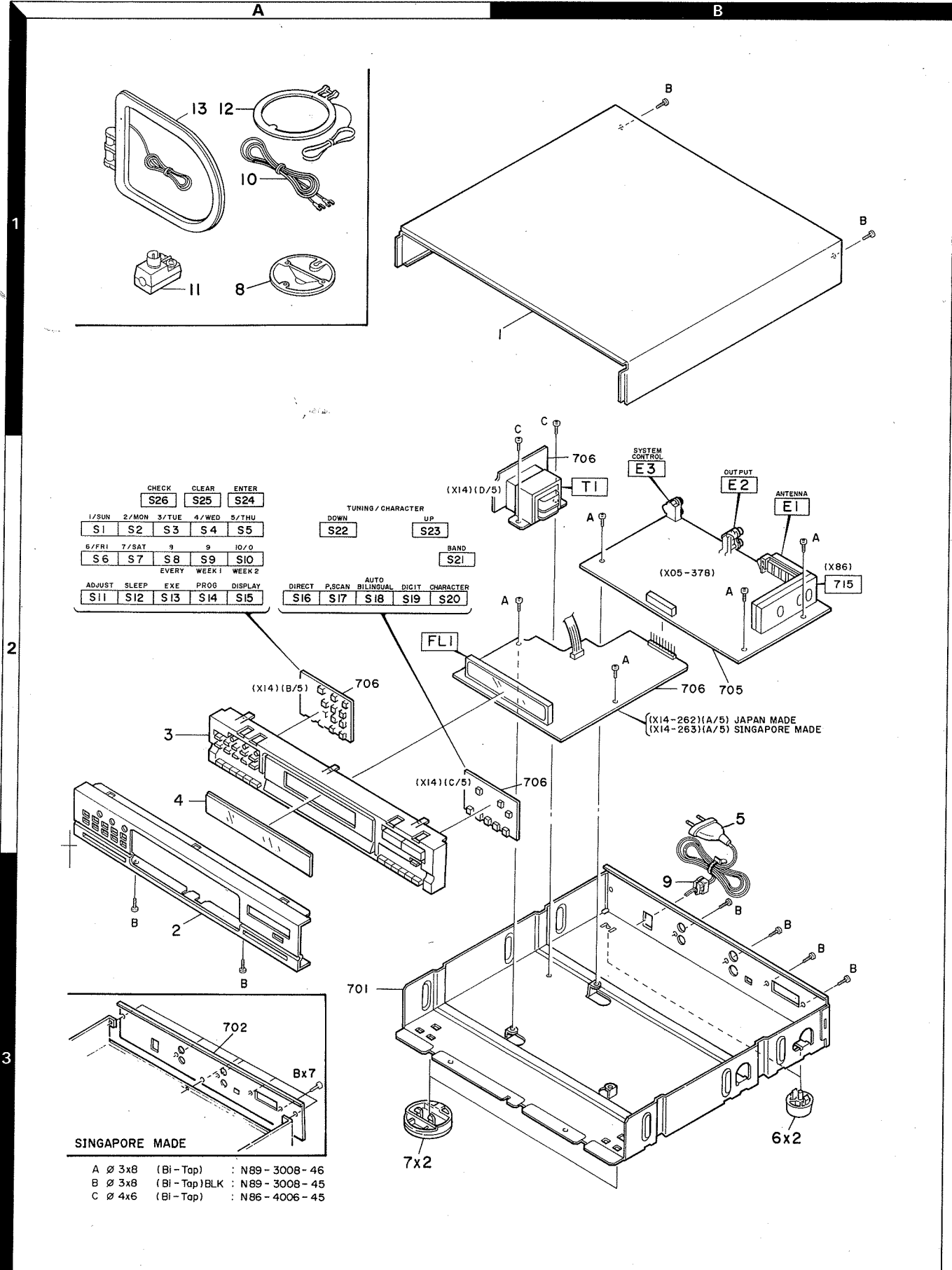

PARTS LIST

* New Parts

Parts without Parts No. are not supplied.

Les articles non mentionnes dans le Parts No. ne sont pas fournis.

Telle ohne Parts No. werden nicht geliefert.

Ref. No. 参照番号	Address 位置	New Parts	Parts No. 部品番号	Description 部品名/規格	Desti- nation 仕向	Re- marks 備考
T-93/93L						
1	1B		A01-1683-01	METALLIC CABINET	MXTE	J
1	1B		A01-1699-01	METALLIC CABINET	TPEF	J
1	1B		A01-1714-01	METALLIC CABINET		S
2	3A	*	A20-5885-02	PANEL	MX	
2	3A	*	A20-5886-02	PANEL	TETPEF	
3	2A		A22-1109-01	SUB PANEL		
4	2A		B10-1033-03	FRONT GLASS		
-			B46-0096-13	WARRANTY CARD	X	
-			B46-0122-13	WARRANTY CARD	E	
-			B46-0129-03	WARRANTY CARD	EF	J
-			B46-0143-03	WARRANTY CARD	T	
-		*	B46-0184-03	WARRANTY CARD	TF	J
-			B58-0803-13	CAUTION CARD	EEF	
△ △ △ 5	2B		E30-0459-05	AC POWER CORD	MEEF	
5	2B		E30-1341-05	AC POWER CORD	X	
5	2B		E30-1416-05	AC POWER CORD	TTF	
-		*	H01-8589-04	ITEM CARTON CASE	MX	J
-		*	H01-8590-04	ITEM CARTON CASE	TE	J
-		*	H01-8591-04	ITEM CARTON CASE	EFTF	J
-		*	H01-8593-04	ITEM CARTON CASE	MX	S
-		*	H01-8594-04	ITEM CARTON CASE	T	S
-		*	H01-8595-04	ITEM CARTON CASE	E	S
-		*	H10-3859-02	POLYSTYRENE FOAMED FIXTURE	MXTE	J
-		*	H10-3860-02	POLYSTYRENE FOAMED FIXTURE	EFTF	J
-		*	H10-3861-02	POLYSTYRENE FOAMED FIXTURE		S
-			H25-0224-04	PROTECTION BAG (800X400X0.03)		
-			H25-0232-04	PROTECTION BAG (235X350X0.03)		
6	3B		J02-0366-15	FOOT (REAR)		
7	3A		J02-1040-05	FOOT (FRONT)		
8	1A		J19-2815-04	ANTENNA HOLDER		
9	3B		J42-0083-05	POWER CORD BUSHING		
-			J61-0307-05	WIRE BAND	XTTF	
A	2B		N89-3008-46	BINDING HEAD TAPTITE SCREW		
B	3A, 3B		N89-3008-45	BINDING HEAD TAPTITE SCREW		
C	2B		N86-4006-45	BINDING HEAD TAPTITE SCREW		
10	1A		T90-0121-05	T TYPE ANTENNA		S
10	1A		T90-0132-05	T TYPE ANTENNA		J
11	1A		T90-0136-05	ANTENNA ADAPTOR	TEBFTF	
12	1A		T90-0153-05	LOOP ANTENNA	EFTF	J
13	1A		T90-0173-05	LOOP ANTENNA	MXTE	J
13	1A		T90-0174-05	LOOP ANTENNA	MXTE	S
TUNER UNIT (X05-378X-XX)						
C1	,2		CK45FF1H103Z	CERAMIC	0.010UF	Z
C3			CF92FV1H223J	MF	0.022UF	J
C3			CF92FV1H473J	MF	0.047UF	J
C4			C91-0769-05	CERAMIC	0.01UF	M
C5			CC45FTH1H101J	CERAMIC	100PF	J
C6			CK45FF1H223Z	CERAMIC	0.022UF	Z
C7	,8		C91-0085-05	CERAMIC	0.022UF	N
C9			CK45FF1H223Z	CERAMIC	0.022UF	Z

E: Scandinavia & Europe K: USA P: Canada

U: PX(Far East, Hawaii) T: England M: Other Areas

UE: AAFES(Europe) X: Australia

J: Japan Made

S: Singapore Made

△ indicates safety critical components.

PARTS LIST

* New Parts

Parts without Parts No. are not supplied.

Les articles non mentionnes dans le Parts No. ne sont pas fournis.

Telle ohne Parts No. werden nicht geliefert.

Ref. No. 参照番号	Address 位置	New Parts	Parts No. 部品番号	Description 部品名/規格	Desti- nation 仕向	Re- marks 備考
C10	,11		C91-0085-05	CERAMIC	0.022UF	N
C11			C91-0085-05	CERAMIC	0.022UF	N
C12			CC45FCH1H151J	CERAMIC	150PF	J
C13			CC93FCH1H221J	CERAMIC	220PF	J
C14			CC93FCH1H391J	CERAMIC	390PF	J
C15			CK45FF1H103Z	CERAMIC	0.010UF	Z
C16			CK45FF1H223Z	CERAMIC	0.022UF	Z
C17	,18		CK45FF1H103Z	CERAMIC	0.010UF	Z
C19	,20		CK45FF1H223Z	CERAMIC	0.022UF	Z
C21			CC45FSL1H101J	CERAMIC	100PF	J
C22			CF92FV1H153J	MF	0.015UF	J
C23			CK45FB1H561K	CERAMIC	560PF	K
C24			CF92FV1H473J	MF	0.047UF	J
C25			CC93FCH1H471J	CERAMIC	470PF	J
C26	,27		CC45FSL1H151J	CERAMIC	150PF	J
C26	,27		CK45FB1H102K	CERAMIC	1000PF	K
C28			CC45FSL1H221J	CERAMIC	220PF	J
C29	,30		CF92FV1H153J	MF	0.015UF	J
C29	,30		CF92FV1H472J	MF	4700PF	J
C31	,32		C91-0749-05	CERAMIC	220PF	K
C33	,34		CF92FV1H432J	MF	4300PF	J
C35			CK45FB1H102K	CERAMIC	1000PF	K
C36	,37		CC45FSL1H221J	CERAMIC	220PF	J
C38			CK45FF1H473Z	CERAMIC	0.047UF	Z
C39	,40		CC45FCH1H220J	CERAMIC	22PF	J
C41	-43		C91-0757-05	CERAMIC	1000PF	K
C44	,45		CK45FF1H103Z	CERAMIC	0.010UF	Z
C46			CK45FF1H223Z	CERAMIC	0.022UF	Z
C50			CK45FF1H103Z	CERAMIC	0.010UF	Z
C55			CK45FF1H103Z	CERAMIC	0.010UF	Z
C59			CC45FSL1H101J	CERAMIC	100PF	J
C61			CE04KW1H010M	ELECTRO	1.0UF	50WV
C62			CE04KW1C101M	ELECTRO	100UF	16WV
C63			CE04KW1H010M	ELECTRO	1.0UF	50WV
C64			CE04KW1C101M	ELECTRO	100UF	16WV
C65			CE04KW1V100M	ELECTRO	10UF	35WV
C66			CE04KW1H2R2M	ELECTRO	2.2UF	50WV
C67			CE04KW1H4R7M	ELECTRO	4.7UF	50WV
C68			CE04KW1V100M	ELECTRO	10UF	35WV
C69			CE04KW1H4R7M	ELECTRO	4.7UF	50WV
C70			CE04KW1HR47M	ELECTRO	0.47UF	50WV
C71			CE04KW1C221M	ELECTRO	220UF	16WV
C72	,73		CE04KW1C220M	ELECTRO	22UF	16WV
C74	-76		CE04KW1H2R2M	ELECTRO	2.2UF	50WV
C74	,75		CE04KW1HR33M	ELECTRO	0.33UF	50WV
C76			CE04KW1H2R2M	ELECTRO	2.2UF	50WV
C77			CE04KW1H3R3M	ELECTRO	3.3UF	50WV
C78			CE04KW1HR47M	ELECTRO	0.47UF	50WV
C79			CE04KW1V100M	ELECTRO	10UF	35WV
C80			CE04KW1C470M	ELECTRO	47UF	16WV
C81			CE04KW1H010M	ELECTRO	1.0UF	50WV
C82			CE04KW1C221M	ELECTRO	220UF	16WV
C83			CE04KW1E221M	ELECTRO	220UF	25WV
TC1			C05-0097-05	CERAMIC	TRIMMER CAPACITOR	(30PF)
TC2			C05-0303-05	CERAMIC	TRIMMER CAPACITOR	(20PF)

E: Scandinavia & Europe K: USA P: Canada

U: PX(Far East, Hawaii) T: England M: Other Areas

UE: AAFES(Europe) X: Australia

J: Japan Made

S: Singapore Made

△ indicates safety critical components.

PARTS LIST

× New Parts
 Parts without Parts No. are not supplied.
 Les articles non mentionnés dans le Parts No. ne sont pas fournis.
 Teile ohne Parts No. werden nicht geliefert.

Ref. No. 参照番号	Address 位置	New Parts	Parts No. 部品番号	Description 部品名/規格	Desti- nation 仕 向	Re- marks 備考
TC3 TC4			C05-0097-05 C05-0303-05	CERAMIC TRIMMER CAPACITOR(30PF) CERAMIC TRIMMER CAPACITOR(20PF)	TEEFTF	
E1 E1 E2 E3	2B 2B 2B 2B		E20-0321-05 E20-0476-05 E13-0249-05 E11-0188-05	LOCK TERMINAL BOARD(ANTENNA) LOCK TERMINAL BOARD(ANTENNA) PHONE JACK (OUTPUT) MINIATURE PHONE JACK	TEEFTF MX	
CF1 ,2 CF1 ,2 CF3 L1 L2			L72-0531-05 L72-0536-05 L72-0096-05 L40-1091-17 L31-0596-05	CERAMIC FILTER CERAMIC FILTER CERAMIC FILTER SMALL FIXED INDUCTOR LW-RF COIL	MX TEEFTF	
L3 L4 L5 L6 L7		*	L31-0509-05 L32-0288-05 L32-0277-15 L30-0454-15 L40-1021-14	MW-RF COIL LW OSCILLATING COIL MW OSCILLATING COIL AM IFT SMALL FIXED INDUCTOR(1.0mH,K)	TEEFTF	
L8 L9 L10 ,11 L12 ,13 L13		*	L30-0439-25 L79-0125-05 L79-0790-05 L40-1091-17 L40-1091-17	FM IFT LC FILTER (B.P.F) LC FILTER SMALL FIXED INDUCTOR(1uH) SMALL FIXED INDUCTOR(1uH)	TEEFTF TEEFTF MX TEEFTF	
X1			L77-1122-05	CRYSTAL RESONATOR(7.2MHz)		
R82 R115 R116-119 R120 VR2			RD14GB2E221J RS14KB3A221J RD14GB2E101J RD14GB2E220J R12-3130-05	FL-PROOF RD 220 J 1/4W FL-PROOF RS 220 J 1W FL-PROOF RD 100 J 1/4W FL-PROOF RD 22 J 1/4W TRIMMING POT.(33K,7t)	TEEFTF	
VR3 VR4			R12-1089-05 R12-5060-05	TRIMMING POT.(4.7K 7t) TRIMMING POT.(220K,7t)	TEEFTF	
S1			S31-2094-05	SLIDE SWITCH(EMPHASIS,CH SPACE)	M	
D1 -8 D1 -8 D1 -8 D1 ,2 D1 ,2			HSS104 1N4148 1SS133 HSS104 1SS133	DIODE DIODE DIODE DIODE DIODE	TE EFTF TE MX MX	J
D7 ,8 D7 ,8 D10 -12 D10 -12 D10 -13			HSS104 1SS133 HSS104 1SS133 HSS104	DIODE DIODE DIODE DIODE DIODE	MX MX MX MX TE	
D10 -13 D10 -13 D14 D14 ,15 D16			1N4148 1SS133 KV1236(Z2) KV1236(Z2) BZX55-C13	DIODE DIODE VARIABLE CAPACITANCE DIODE VARIABLE CAPACITANCE DIODE DIODE	EFTF TE MX TEEFTF EFTF	J J
D16 D16 D17 D17 D17		*	HZS13N(B2) RD13ES(B2) BZX55-C3V3 HZS3.3N(B2) RD3.3ES(B2)	ZENER DIODE ZENER DIODE ZENER DIODE ZENER DIODE ZENER DIODE	MXTE MXTE EFTF MXTE MXTE	J
D18 D18			HSS104 1SS133	DIODE DIODE	MX MX	

E: Scandinavia & Europe K: USA P: Canada
 U: PX(Far East, Hawaii) T: England M: Other Areas
 UE: AAFES(Europe) X: Australia

J: Japan Made
 S: Singapore Made

△ indicates safety critical components.

PARTS LIST

× New Parts
 Parts without Parts No. are not supplied.
 Les articles non mentionnés dans le Parts No. ne sont pas fournis.
 Teile ohne Parts No. werden nicht geliefert.

Ref. No. 参照番号	Address 位置	New Parts	Parts No. 部品番号	Description 部品名/規格	Desti- nation 仕 向	Re- marks 備考
D18 -20 D18 -20 D18 -20 D20 D20			HSS104 1N4148 1SS133 HSS104 1SS133	DIODE DIODE DIODE DIODE DIODE	TE EFTF TE MX MX	J
D22 D22 D22 IC1 IC2			BZX55-C6V2 HZS6.2N(B2) RD6.2ES(B2) LM7001 LA1265	DIODE ZENER DIODE ZENER DIODE IC(PLL FREQUENCY SYNTHESIZER) IC(FM/AM TUNER)	EFTF MXTE MXTE	J
IC3 Q1 Q2 Q2 Q2			AN7470 2SC1923(R,0) JC501(P,Q) 2SC1740S(Q,R) 2SC945(A)(Q,P)	IC(FM MPX) TRANSISTOR TRANSISTOR TRANSISTOR TRANSISTOR	EFTF MXTE MXTE	J
Q3 Q4 Q4 Q6 -8 Q6 -8			2SC1845(F,E) 2SK163(L,M) 2SK364(GR,BL) JC501(P,Q) 2SC1740S(Q,R)	TRANSISTOR FET FET TRANSISTOR TRANSISTOR	TE TEEFTF EFTF TE	S J J
Q6 -8 Q11 Q11 Q11 Q13			2SC945(A)(Q,P) JC501(P,Q) 2SC1740S(Q,R) 2SC945(A)(Q,P) JA101(P,Q)	TRANSISTOR TRANSISTOR TRANSISTOR TRANSISTOR TRANSISTOR	TE EFTF TE TE EFTF	J J
Q13 Q13 Q15 Q15 Q15			2SA733(A)(Q,P) 2SA933S(Q,R) JA101(P,Q) 2SA733(A)(Q,P) 2SA933S(Q,R)	TRANSISTOR TRANSISTOR TRANSISTOR TRANSISTOR TRANSISTOR	MXTE MXTE EFTF MXTE MXTE	J
Q16 Q17 ,18 Q19 ,20 Q19 ,20 Q21			2SC2003(L,K) 2SD1302(S,T) 2SC1740S(Q,R) 2SC945(A)(Q,P) 2SD1266(Q,P)	TRANSISTOR TRANSISTOR TRANSISTOR TRANSISTOR TRANSISTOR	M M	
Q22 Q22 Q22 Q23 Q23			JA101(P,Q) 2SA733(A)(Q,P) 2SA933S(Q,R) JC501(P,Q) 2SC1740S(Q,R)	TRANSISTOR TRANSISTOR TRANSISTOR TRANSISTOR TRANSISTOR	EFTF MXTE MXTE EFTF MXTE	J
Q23 Q24 Q24 ,25 Q24 ,25			2SC945(A)(Q,P) 2SA733(A)(Q,P) 2SA933S(Q,R) JA101(P,Q) 2SA733(A)(Q,P)	TRANSISTOR TRANSISTOR TRANSISTOR TRANSISTOR TRANSISTOR	MXTE MX MX EFTF TE	J
Q24 ,25			2SA933S(Q,R)	TRANSISTOR	TE	
DISPLAY UNIT (X14-262X-XX: Japan Made, X14-263X-XX: Singapore Made)						
C1 C2 C3 C4 ,5 C6			CE04KW0J222M CE04KW1V100M CK45FF1H103Z CC45FCH1H330J CE04KW1HR47M	ELECTRO ELECTRO CERAMIC CERAMIC ELECTRO	2200UF 6.3WV 10UF 35WV 0.010UF Z 33PF J 0.47UF 50WV	
C7 C8 ,9			CE04KW1V102M CK45FF1H103Z	ELECTRO CERAMIC	1000UF 35WV 0.010UF Z	

E: Scandinavia & Europe K: USA P: Canada
 U: PX(Far East, Hawaii) T: England M: Other Areas
 UE: AAFES(Europe) X: Australia

J: Japan Made
 S: Singapore Made

△ indicates safety critical components.

PARTS LIST

× New Parts
 Parts without Parts No. are not supplied.
 Les articles non mentionnés dans le Parts No. ne sont pas fournis.
 Teile ohne Parts No. werden nicht geliefert.

Ref. No. 参照番号	Address 位置	New Parts 新	Parts No. 部品番号	Description 部品名 / 規格	Desti- nation 仕 向	Re- marks 備考
C14 C15 ,16 C17 C18 C19			CE04KW1E101M CK45FF1H103Z CE04KW1H101M C90-1400-05 CK45FF1H103Z	ELECTRO 100UF 25WV CERAMIC 0.010UF Z ELECTRO 100UF 50WV NP-ELEC 10UF 50WV CERAMIC 0.010UF Z		
T1 T1 T1 T1 T1	2B 2B 2B 2B 2B	* * * *	L01-5452-05 L01-5452-05 L01-5454-15 L01-9002-05 L01-9004-05	POWER TRANSFORMER POWER TRANSFORMER POWER TRANSFORMER POWER TRANSFORMER POWER TRANSFORMER	XTEBF TF M XTE M	J J J S S
X1			L77-1175-05	CRYSTAL RESONATOR(4.194304MHZ)		
R48 ,49 R76 R76 R76			RS14KB3D471J RS14KB3A101J RS14KB3A151J RS14KB3A820J	FL-PROOF RS 470 J 2W FL-PROOF RS 100 J 1W FL-PROOF RS 150 J 1W FL-PROOF RS 82 J 1W	X M TEBTF	
S1 -26 S27	2A		S40-1064-05 S31-2128-05	PUSH SWITCH (1-10/0,ADJ. SLIDE SWITCH (POWER TYPE)	M	
D1 -6 D1 -6 D1 -6 D7 D7			HSS104 1N4148 1SS133 BZX55-C5V1 HZS5.1N(B)	DIODE DIODE DIODE ZENER DIODE ZENER DIODE	MXTE EFTF MXTE EFTF MXTE	J J J
D7 D8 D8 D8 D10 -12			RD5.1ES(B) HSS104 1N4148 1SS133 HSS104	ZENER DIODE DIODE DIODE DIODE DIODE	MXTE TE EFTF TE XTE	J
D10 -12 D10 -12 D11 ,12 D11 ,12 D13			1N4148 1SS133 HSS104 1SS133 BZX55-C5V1	DIODE DIODE DIODE DIODE ZENER DIODE	EFTF XTE M M EFTF	J J
D13 D13 D14 -17 D14 ,15 D16 ,17			HZS5.1N(B) RD5.1ES(B) 1N4004 S5566B HSS104A	ZENER DIODE ZENER DIODE DIODE DIODE DIODE	MXTE MXTE EFTF MXTE MXTE	J
D16 ,17 D20 -25 D20 -25 D20 -25 D28			1SS131 HSS104 1N4148 1SS133 HSS104	DIODE DIODE DIODE DIODE DIODE	MXTE MXTE EFTF MXTE MXTE	J
D28 D28 FL1 IC1 Q1 ,2	2A		1N4148 1SS133 FIP8CSM7 CXP50112-010Q JC501(P,Q)	DIODE DIODE FLUORESCENT INDICATOR TUBE IC(MICROPROCESSOR) TRANSISTOR	EFTF MXTE	J
Q1 ,2 Q1 ,2 Q3 ,4 Q3 ,4 Q4			2SC1740S(Q,R) 2SC945(A)(Q,P) 2SA733(A)(Q,P) 2SA933S(Q,R) JA101(P,Q)	TRANSISTOR TRANSISTOR TRANSISTOR TRANSISTOR TRANSISTOR	MXTE MXTE M M EFTF	J
Q4			2SA733(A)(Q,P)	TRANSISTOR	XTE	

E: Scandinavia & Europe K: USA P: Canada
 U: PX(Far East, Hawaii) T: England M: Other Areas
 UE: AAFES(Europe) X: Australia

J: Japan Made
 S: Singapore Made

⚠ indicates safety critical components.

PARTS LIST

× New Parts
 Parts without Parts No. are not supplied.
 Les articles non mentionnés dans le Parts No. ne sont pas fournis.
 Teile ohne Parts No. werden nicht geliefert.

Ref. No. 参照番号	Address 位置	New Parts 新	Parts No. 部品番号	Description 部品名 / 規格	Desti- nation 仕 向	Re- marks 備考
Q4 Q5 Q5 Q5			2SA933S(Q,R) JC501(P,Q) 2SC1740S(Q,R) 2SC945(A)(Q,P)	TRANSISTOR TRANSISTOR TRANSISTOR TRANSISTOR	XTE EFTF MXTE MXTE	J
T-93 FRONT END UNIT (X86-1040-10: Japan Made, X86-1130-10: Singapore Made)						
C1 C2 C3 C4 C5			CC41FSL1H060D C93-0012-05 CC41FSL1H100D C93-0012-05 CK41FB1H221K	CYLND CHIP C 6.0PF D CYLND CHIP C 0.01UF M CYLND CHIP C 10PF D CYLND CHIP C 0.01UF M CYLND CHIP C 220PF K		MX MX MX MX MX
C6 C8 C9 C10 C11			CC41FSL1H070D CC41FSL1H020C CK41FB1H221K C93-0012-05 CC41FSL1H080D	CYLND CHIP C 7.0PF D CYLND CHIP C 2.0PF C CYLND CHIP C 220PF K CYLND CHIP C 0.01UF M CYLND CHIP C 8.0PF D		MX MX MX MX MX
C12 C14 C16 C17 C18			CC41FSL1H010C C93-0012-05 CC41FSL1H080D CC41FSL1H330J CC41FSL1H150J	CYLND CHIP C 1.0PF C CYLND CHIP C 0.01UF M CYLND CHIP C 8.0PF D CYLND CHIP C 33PF J CYLND CHIP C 15PF J		MX MX MX MX MX
C19 C20 C21 TC1			CC41FSL1H010C CK41FY1E102M CC41FSL1H470J C05-0302-05	CYLND CHIP C 1.0PF C CYLND CHIP C 1000PF M CYLND CHIP C 47PF J CERAMIC TRIMMER CAPACITOR(11PF)		MX MX MX MX
L1 L2 L3 L4 L7			L31-0551-05 L31-0552-05 L31-0553-05 L40-1092-16 L32-0318-05	FM-RF COIL FM-RF COIL FM-RF COIL SMALL FIXED INDUCTOR(1UH,M) FM OSCILLATING COIL		MX MX MX MX MX
T1			L30-0427-15	FM IFT		MX
R1 ,2 R3 R4			R92-0338-05 R92-0350-05 RD41FB2B473J RD41FB2B470J RD41FB2B331J	CLYND CHIP R 0 OHM JUMPER WIRE (RESISTOR TYPE) CYLND CHIP R 47K J 1/8W CYLND CHIP R 47 J 1/8W CYLND CHIP R 330 J 1/8W		MX MX MX MX
R5 R6 R9 R11 R14			RD41FB2B101J RD41FB2B473J RD41FB2B105J RD41FB2B101J RD41FB2B472J	CYLND CHIP R 100 J 1/8W CYLND CHIP R 47K J 1/8W CYLND CHIP R 1.0M J 1/8W CYLND CHIP R 100 J 1/8W CYLND CHIP R 4.7K J 1/8W		MX MX MX MX MX
R15 ,16 R17 R18 R19 ,20			RD41FB2B223J RD41FB2B222J RD41FB2B224J RD41FB2B101J	CYLND CHIP R 22K J 1/8W CYLND CHIP R 2.2K J 1/8W CYLND CHIP R 220K J 1/8W CYLND CHIP R 100 J 1/8W		MX MX MX MX
D1 -3 Q1 Q2 Q4 ,5			KV1310A-3 2SK302(Y,GR) 2SC2714(O) 2SC2714(R,O)	VARIABLE CAPACITANCE DIODE FET TRANSISTOR TRANSISTOR		MX MX MX MX
T-93L FRONT END UNIT (X86-1052-70: Japan Made, X86-1122-70: Singapore Made)						
C1 C2			CC41FSL1H060D C93-0012-05	CYLND CHIP C 6.0PF D CYLND CHIP C 0.01UF M	TEBTF TEBTF	

E: Scandinavia & Europe K: USA P: Canada
 U: PX(Far East, Hawaii) T: England M: Other Areas
 UE: AAFES(Europe) X: Australia

J: Japan Made
 S: Singapore Made

⚠ indicates safety critical components.

PARTS LIST

※ New Parts

Parts without Parts No. are not supplied.

Les articles non mentionnés dans le Parts No. ne sont pas fournis.

Telle ohne Parts No. werden nicht geliefert.

Ref. No. 参照番号	Address 位置	New Parts 新	Parts No. 部品番号	Description 部品名 / 規格	Desti- nation 仕向	Re- marks 備考
C3			CC41FSL1H100D	CYLND CHIP C 10PF D	TEEFTF	
C4			C93-0012-05	CYLND CHIP C 0.01UF M	TEEFTF	
C5			CK41FB1H221K	CYLND CHIP C 220PF K	TEEFTF	
C6			CC41FSL1H100D	CYLND CHIP C 10PF D	TEEFTF	
C7			CC41FSL1H060D	CYLND CHIP C 6.0PF D	TEEFTF	
C8			CC41FSL1H100D	CYLND CHIP C 10PF D	TEEFTF	
C9			CK41FB1H221K	CYLND CHIP C 220PF K	TEEFTF	
C10			C93-0012-05	CYLND CHIP C 0.01UF M	TEEFTF	
C11			CK41FY1E102M	CYLND CHIP C 1000PF M	TEEFTF	
C12			CC41FSL1H030C	CYLND CHIP C 3.0PF C	TEEFTF	
C13			CC41FSL1H100D	CYLND CHIP C 10PF D	TEEFTF	
C14			C93-0012-05	CYLND CHIP C 0.01UF M	TEEFTF	
C16			CC41FSL1H080D	CYLND CHIP C 8.0PF D	TEEFTF	
C17			CC41FSL1H330J	CYLND CHIP C 33PF J	TEEFTF	
C18			CC41FSL1H150J	CYLND CHIP C 15PF J	TEEFTF	
C19			CC41FSL1H010C	CYLND CHIP C 1.0PF C	TEEFTF	
C20			CK41FY1E102M	CYLND CHIP C 1000PF M	TEEFTF	
C21			CC41FSL1H470J	CYLND CHIP C 47PF J	TEEFTF	
TC1			C05-0302-05	CERAMIC TRIMMER CAPACITOR(11PF)	TEEFTF	
L1			L31-0551-05	FM-RF COIL	TEEFTF	
L2			L31-0552-05	FM-RF COIL	TEEFTF	
L3			L31-0553-05	FM-RF COIL	TEEFTF	
L4			L40-1092-16	SMALL FIXED INDUCTOR(1UH,M)	TEEFTF	
L5			L31-0554-05	FM-RF COIL	TEEFTF	
L7			L32-0318-05	FM OSCILLATING COIL	TEEFTF	
T1			L30-0427-15	FM IFT	TEEFTF	
			R92-0338-05	CYLND CHIP R 0 OHM	TEEFTF	
			R92-0350-05	JUMPER WIRE (RESISTOR TYPE)	TEEFTF	
R1			RD41FB2B473J	CYLND CHIP R 47K J 1/8W	TEEFTF	
R2			RD41FB2B104J	CYLND CHIP R 100K J 1/8W	TEEFTF	
R3			RD41FB2B470J	CYLND CHIP R 47 J 1/8W	TEEFTF	
R4			RD41FB2B331J	CYLND CHIP R 330 J 1/8W	TEEFTF	
R5			RD41FB2B101J	CYLND CHIP R 100 J 1/8W	TEEFTF	
R6 ,7			RD41FB2B473J	CYLND CHIP R 47K J 1/8W	TEEFTF	
R8 ,9			RD41FB2B104J	CYLND CHIP R 100K J 1/8W	TEEFTF	
R11			RD41FB2B101J	CYLND CHIP R 100 J 1/8W	TEEFTF	
R12			RD41FB2B681J	CYLND CHIP R 680 J 1/8W	TEEFTF	
R13			RD41FB2B104J	CYLND CHIP R 100K J 1/8W	TEEFTF	
R14			RD41FB2B472J	CYLND CHIP R 4.7K J 1/8W	TEEFTF	
R15 ,16			RD41FB2B223J	CYLND CHIP R 22K J 1/8W	TEEFTF	
R17			RD41FB2B222J	CYLND CHIP R 2.2K J 1/8W	TEEFTF	
R18			RD41FB2B224J	CYLND CHIP R 220K J 1/8W	TEEFTF	
R19 ,20			RD41FB2B101J	CYLND CHIP R 100 J 1/8W	TEEFTF	
D1 -4			KV1310-4	VARIABLE CAPACITANCE DIODE	TEEFTF	
Q1			2SK302(Y,GR)	FET	TEEFTF	
Q2			3SK131(M,L)	FET	TEEFTF	
Q3			2SK302(Y,GR)	FET	TEEFTF	
Q4 ,5			2SC2714(R,Ø)	TRANSISTOR	TEEFTF	

E: Scandinavia & Europe K: USA

P: Canada

U: PX(Far East, Hawaii)

T: England

M: Other Areas

UE: AAFES(Europe)

X: Australia

J: Japan Made

S: Singapore Made

 indicates safety critical components.

T-93/93L

SPECIFICATIONS

T-93L

FM tuner section

Tuning frequency range87.5 MHz~108 MHz

Usable sensitivity (DIN at 75 Ω)

MONO0.8 μ V

STEREO28.1 μ V

Total harmonic distortion (DIN at 1 kHz, 65.2 dBf input)

MONO0.2%

STEREO0.5%

Signal to noise ratio (DIN weighted at 1 kHz, 65.2 dBf input)

MONO67 dB

STEREO63 dB

Stereo separation (DIN at 1 kHz)....46 dB

Alternate channel selectivity

(DIN \pm 300 kHz)67 dB

Frequency response

(30 Hz ~ 15 kHz)+0.5 dB, -2.5 dB

Output level/Impedance

(at 75 kHz dev.).....0.6 V/3.3 k Ω

MW Tuner Section

Tuning frequency range531 kHz~1,602 kHz

Usable sensitivity17 μ V/800 μ V/m

Signal to noise ratio

(at 30% mod. 1 mV input).....49 dB

LW Tuner section

Tuning frequency range153 kHz~281 kHz

Usable sensitivity20 μ V/1000 μ V/m

Signal to noise ratio

(at 30% mod. 1 mV input).....47 dB

General

Power consumption.....9 W

DimensionW: 360 mm

H: 70 mm

D: 354 mm

Weight.....2.7 kg

T-93

FM tuner section

Tuning frequency range87.5 MHz~108 MHz

Usable sensitivity (IHF at 75 Ω).....0.95 μ V/10.8 dBf

Total harmonic distortion (at 1 kHz, 65 dBf input)

MONO0.4%

STEREO0.45%

Signal to noise ratio (at 1 kHz, 65 dBf input)

MONO78 dB

STEREO71 dB

Stereo separation (at 1 kHz).....40 dB

Alternate channel selectivity

(\pm 400 kHz).....56 dB

Frequency response

(30 Hz ~ 15 kHz)+0.5 dB, -2.5 dB

Output level/Impedance

(at 75 kHz dev.).....0.6 V/3.3 k Ω

AM Tuner Section

Tuning frequency range

531 kHz ~ 1,602 kHz9 kHz step

530 kHz ~ 1,610 kHz10 kHz step

Usable sensitivity17 μ V/800 μ V/m

Signal to noise ratio

(at 30% mod. 1 mV input).....49 dB

General

Power consumption.....9 W

DimensionW: 360 mm

H: 70 mm

D: 354 mm

Weight.....2.7 kg

KENWOOD follows a policy of continuous advancements in development. For this reason specifications may be changed without notice.

KENWOOD poursuit une politique de progrès constants en ce qui concerne le développement. Pour cette raison, les spécifications sont sujettes à modifications sans préavis.

KENWOOD strebt ständige, Verbesserungen in der Entwicklung an. Daher bleiben Änderungen der technischen Daten jederzeit vorbehalten.

KENWOOD CORPORATION

Shionogi Shibuya Building, 17-5, 2-chome Shibuya, Shibuya-ku, Tokyo 150, Japan

KENWOOD U.S.A. CORPORATION

2201 East Dominguez Street, Long Beach, CA 90810;

550 Clark Drive, Mount Olive, NJ 07828, U.S.A.

KENWOOD ELECTRONICS CANADA INC.

P.O. BOX 1075, 959 Gana Court, Mississauga, Ontario, Canada L4T 4C2

TRIO-KENWOOD U.K. LIMITED

17 Bristol Road, The Metropolitan Centre, Greenford, Middx. UB6 8UP England

KENWOOD ELECTRONICS BENELUX N.V.

Mechelsesteenweg 418 B-1930 Zaventem, Belgium

KENWOOD ELECTRONICS DEUTSCHLAND GMBH

Rembrücker-Str. 15, 6056 Heusenstamm, West Germany

TRIO-KENWOOD FRANCE S.A.

13 Boulevard Ney, 75018 Paris, France

KENWOOD LINEAR S.p.A.

20125, MILANO-VIA ARBE, 50, ITALY

KENWOOD ELECTRONICS AUSTRALIA PTY. LTD. (INCORPORATED IN N.S.W.)

4E Woodcock Place, Lane Cove, N.S.W. 2066, Australia

KENWOOD & LEE ELECTRONICS, LTD.

Wang Kee Building, 4th Floor, 34-37, Connaught Road, Central, Hong Kong