

KRF-X9995D/X9995D-S

VR-5700/5900

SERVICE MANUAL

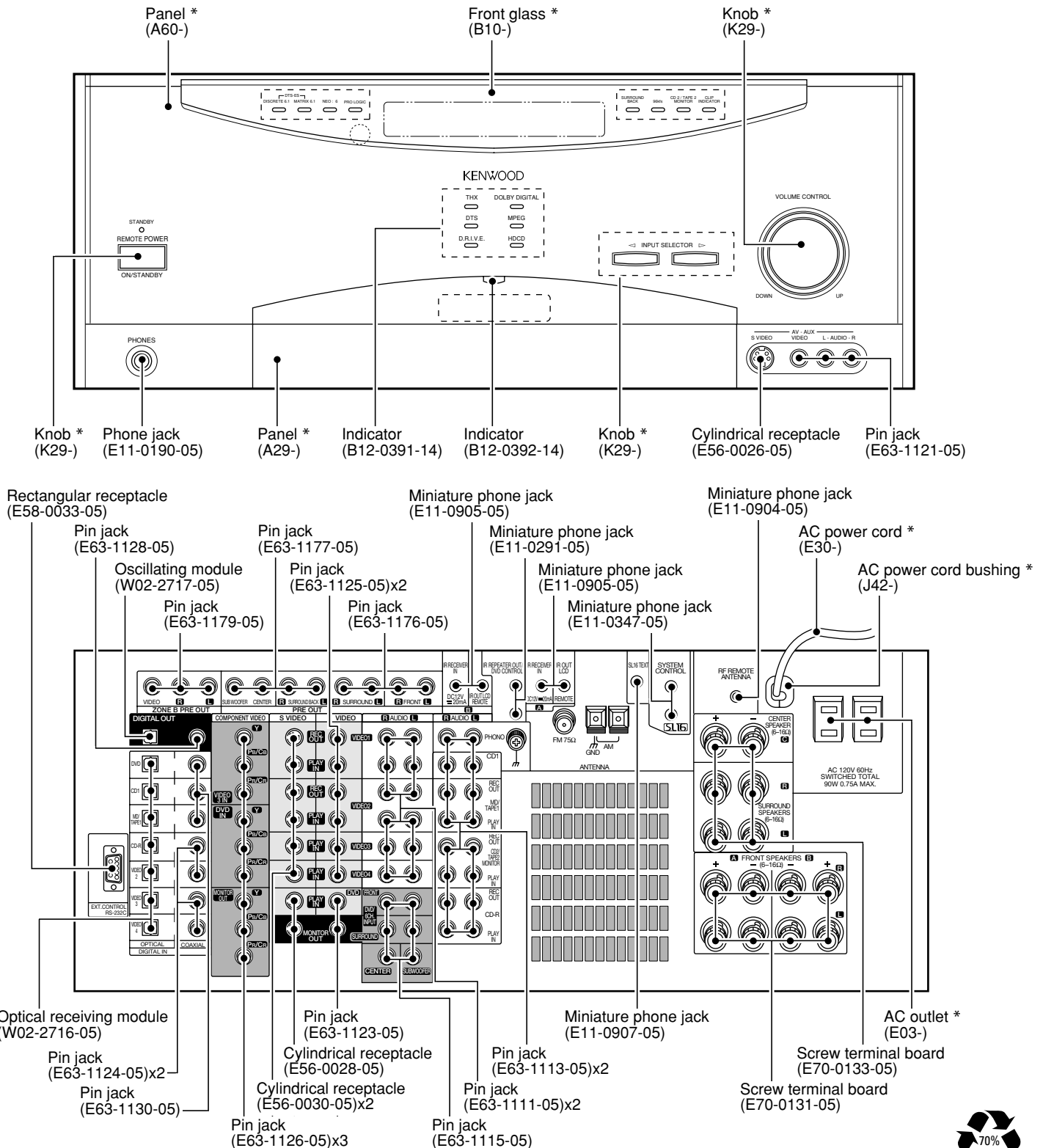

Illust is VR-5700.

* Refer to parts list on page 62.









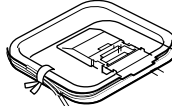

CONTENTS / ACCESSORIES

Contents

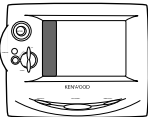
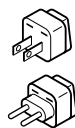
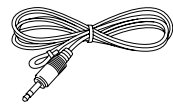
CONTENTS / ACCESSORIES	2	PC BOARD	17
DISASSEMBLY FOR REPAIR	3	SCHEMATIC DIAGRAM	30
BLOCK DIAGRAM	5	EXPLODED VIEW	60
ADJUSTMENT	14	PARTS LIST	62
WIRING DIAGRAM	16	SPECIFICATIONS	88

Accessories

<p>Remote control unit (A70-1453-05): RC-R0913</p>  <p>Battery cover(A09-1166-08)</p>	<p>Batteries</p> 	<p>AM Loop Antenna (T90-0852-05)</p> 	<p>FM Antenna (T90-0855-05)</p> 
<p>Remote control unit (PowerTouch) (A70-1456-05): RC-R1111 (A70-1457-05): RC-R1012 (A70-1458-05): RC-R1013</p>  <p>Battery cover(A09-1177-08) Pen(W01-0976-08)</p>	<p>AC plug adaptor *..... (1)</p>  <p>Use to adapt the plug on the power cord to the shape of the wall outlet. (Accessory only for regions where use is necessary.)</p> <p>* Refer to parts list.</p>		<p>Antenna ass'y (T90-0850-05) U.S.A. only</p> 

	
<p>Manufactured under license from Dolby Laboratories. Dolby , Pro Logic , AC-3 , and the double-D symbol are trademarks of Dolby Laboratories. Confidential Unpublished Works. ' 1992-1997 Dolby Laboratories. All rights reserved.</p>	
	
<p>Manufactured under license from Digital Theater Systems, Inc. US Pat. No. 5,451,942 and other worldwide patents issues and pending. DTS and DTS Digital Surround are trademarks of Digital Theater Systems, Inc. ' 1996 Digital Theater Systems, Inc. All rights reserved.</p>	



<p>[HDCD], HDCD[®], High Definition Compatible Digital[®] and Pacific Microsonics[™] are either registered trademarks or trademarks of Pacific Microsonics, Inc. in the United States and/or other countries. HDCD system manufactured under license from Pacific Microsonics, Inc. This product is covered by one or more of the following: IN the USA: 5,479,168, 5,638,074, 5,640,161, 5,808,574, 5,838,274, 5,854,600, 5,864,311, 5,872,531, and in Australia: 669114. Other patents pending.</p>

DISASSEMBLY FOR REPAIR

How to Remove the Front Panel and the Motor Assy

1. How to Remove the Front Panel

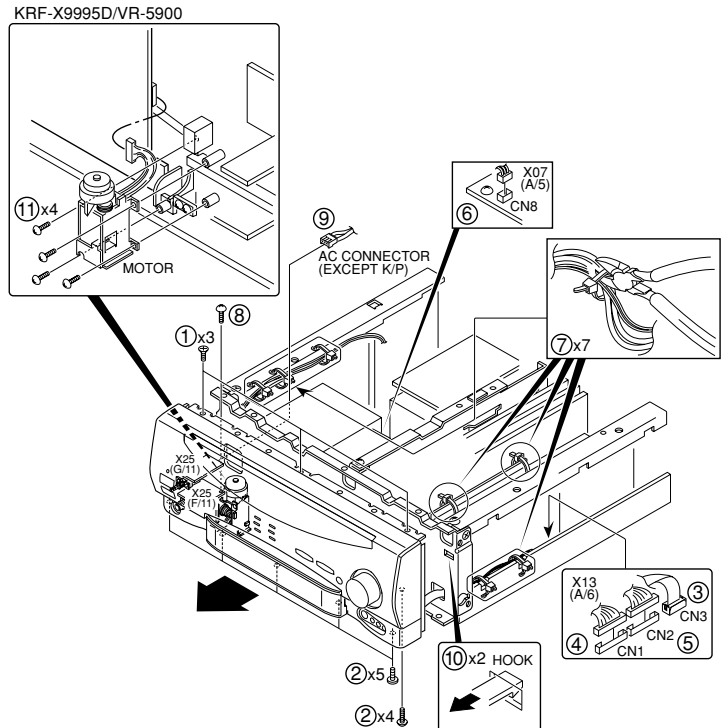
1. Remove the screws (①X3) on top of the panel.
2. Remove the screws (②X9) located at the the bottom of the panel.
3. Disconnect the cable (③) and connectors (④,⑤) on the X13 A/6.
4. Disconnect the connector (⑥) on the X07 A/5.
5. Cut the tie band (⑦X7) as shown in the figure.
6. Remove the screw (⑧X1) on the X25 F/11.
7. Disconnect the connector (⑨) on the X25 G/11.(Except K/P type)
8. Remove the hooks (⑩X2) on the sub panel.
9. Remove the front panel in the direction of arrow.



2. How to Remove the Motor Assy

1. The motor assy can be separated by removing screws (⑪X4).

Disassembling the Rear Panel and How to Replace the Power Transistor

1. Disconnect the CN10 on the X07 C/5.
2. Remove all of screws (①X61) and digital caps (②X8) on the rear panel.
(The number of screws and caps are vary according to the models).
3. Disconnect the cable CN16 (③) on the X13 A/6.
4. Disconnect the flexible cables CN101(④) on the X25 C/11, CN102 (⑤) and * CN103 (⑥)on the X25 B/11.
* (K/P type only).
5. Remove the rear panel in the direction of arrow.
6. Remove the screw (⑦), then remove the X25 B/11.

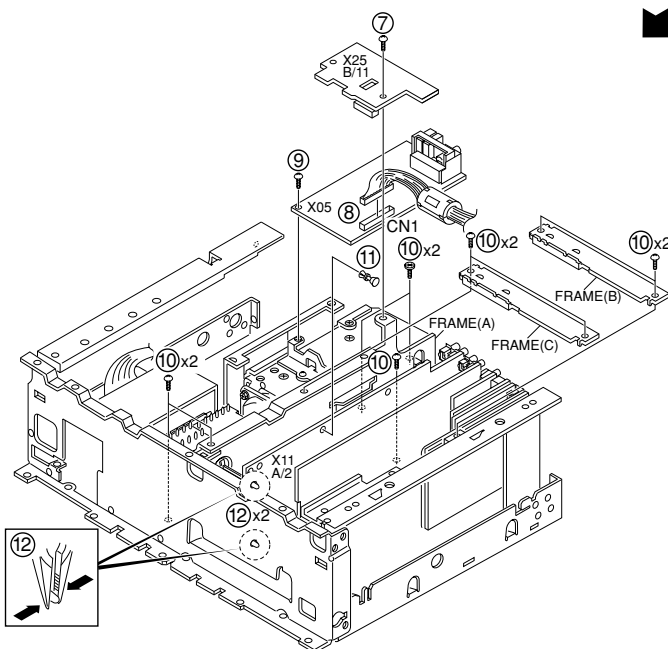
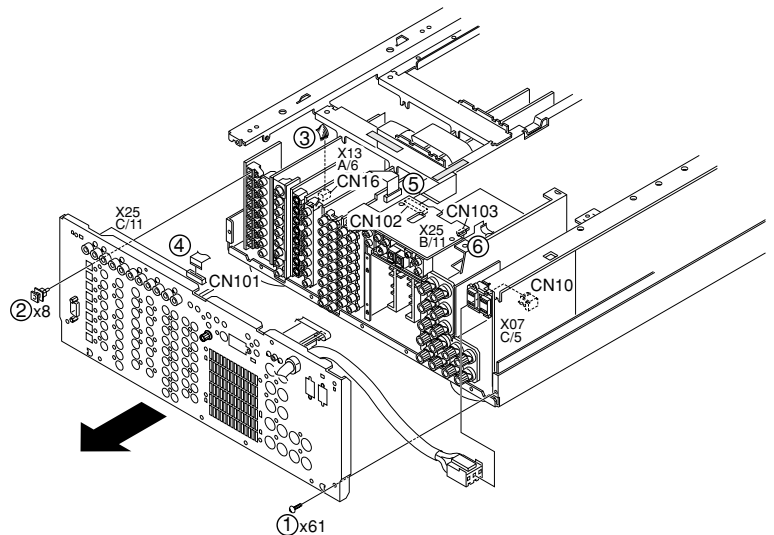

7. To remove the tuner unit, disconnect the CN1 (⑧) and remove a screw (⑨).
8. Remove the screws (⑩X9) on the frames (A/B/C), push rivet (⑪) and PC support (⑫x2)on the X11 A/2.

DISASSEMBLY FOR REPAIR

- To remove the frame A rearward, cut the tie bands (13X4) on the frames.
- Remove a screw (14), then remove a thermostat.

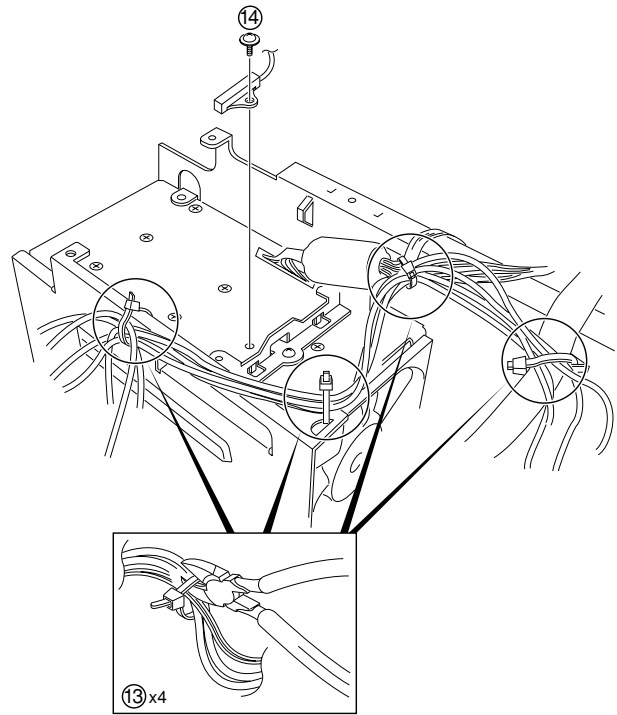

- Remove the screws (15X10), then remove a frame (D), a cover and X07 B/5.
- To remove a power amplifier unit (X07 A/5), remove the screws (16x4), and a PC support (17x2).
- Set up the X07 A/5 in the direction of arrow as shown in the figure.
- Replace the defective transistor.

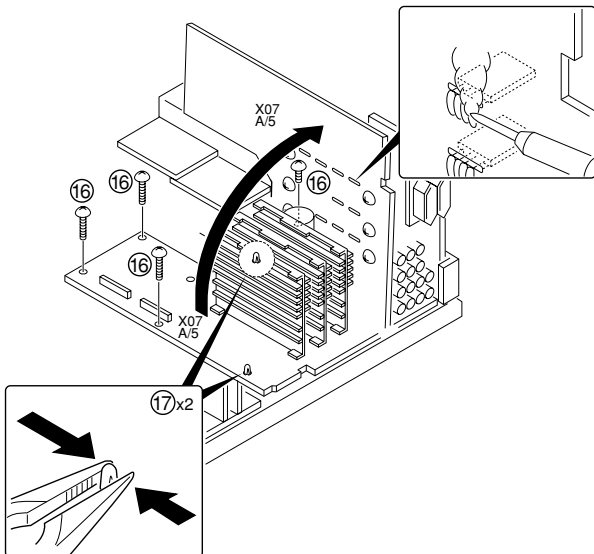
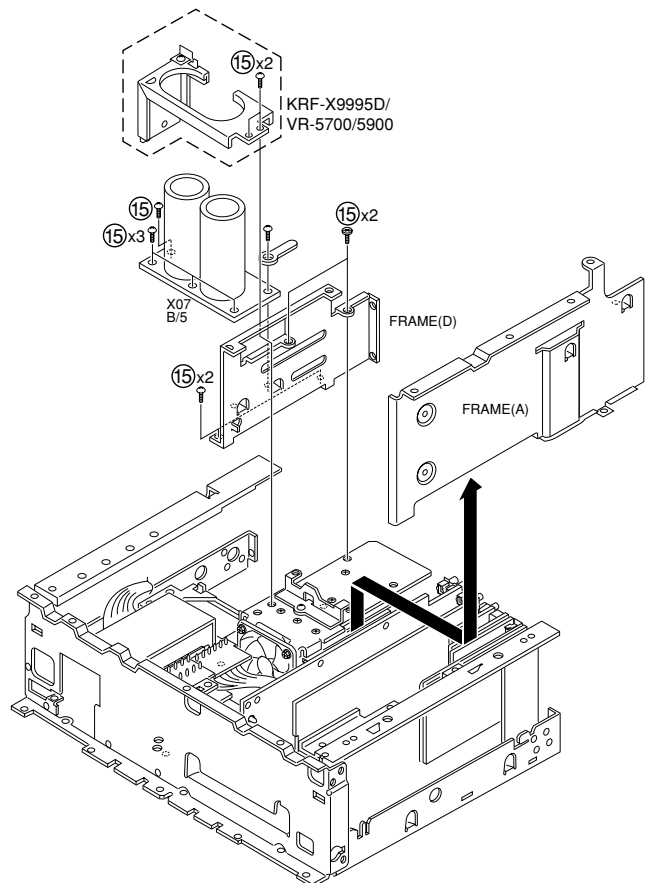

BLOCK DIAGRAM

KRF-X9995D/X9995D-S/VR-5700/5900

VIDEO SECTION

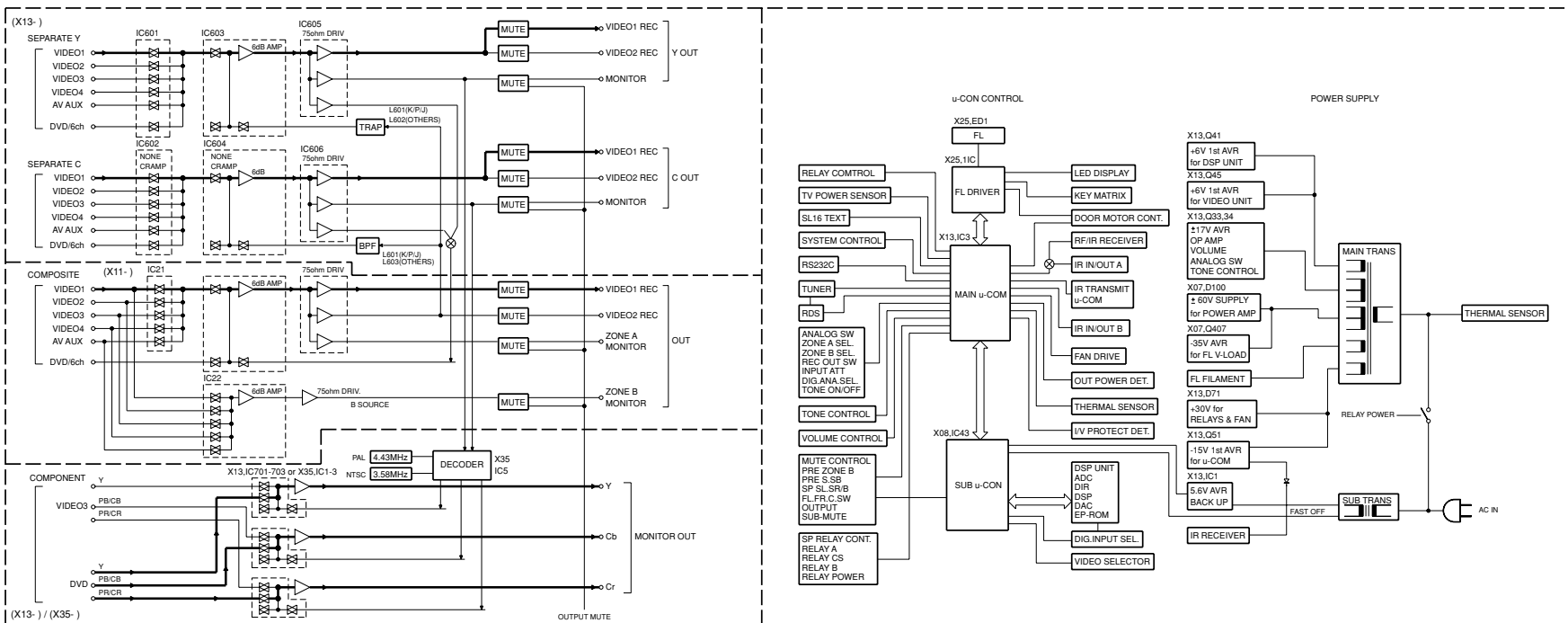

(X13-)/(X35-)

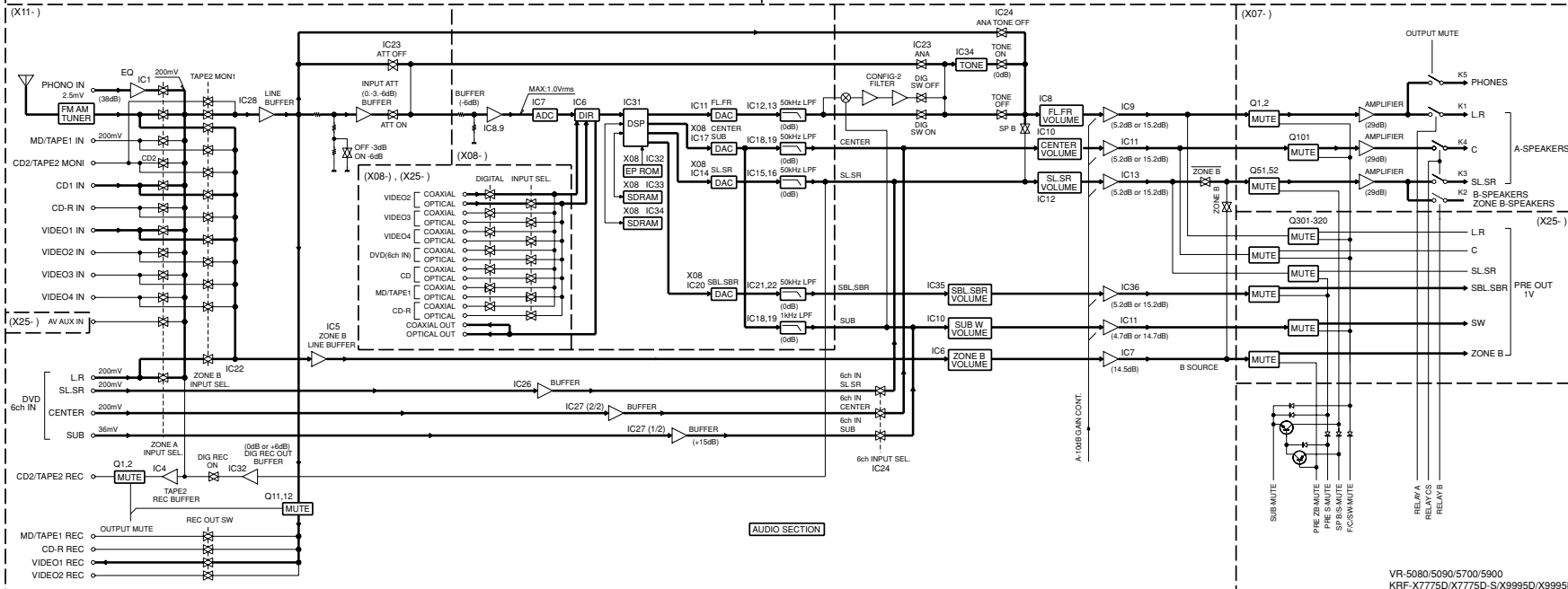

AUDIO SECTION

VR-5080/5090/5700/5900
KRF-X7775D/X7775D-S/X9995D/X9995D-S

CIRCUIT DESCRIPTION

1. Initialization

1-1 The Initial Setting

- Insert the power cord to AC wall outlet by pressing the "POWER" key ON/STANDBY.

2. Destination List of Tuner

0 : Pull down, 1: Pull up

SET TYPE	TYPE	BAND	RECEIVING FREQUENCY RANGE	CHANNEL SPACE	IF	PLL	DIODE SW(X13) ※1			
							DSW3 (R282,R285)	DSW2 (R292,R279)	DSW1 (R296,R284)	DSW0 (R297,R288)
K, P, R	K1 1700	FM	87.5MHz-108.0MHz	100kHz	+10.7MHz	25kHz	0	0	0	0
		AM	530kHz-1700kHz	10kHz	+450kHz	10kHz				
Y, M, I, C, V	K2 1610	FM	87.5MHz-108.0MHz	100kHz	+10.7MHz	25kHz	0	0	1	1
		AM	530kHz-1610kHz	10kHz	+450kHz	10kHz				
K, P	K4 1700 RBDS	FM	87.5MHz-108.0MHz	100kHz	+10.7MHz	25kHz	1	0	1	0
		AM	530kHz-1700kHz	10kHz	+450kHz	10kHz				
Y, M, I, C, V, E, X, H	E1	FM	87.5MHz-108.0MHz	50kHz	+10.7MHz	25kHz	0	0	0	1
		AM	531kHz-1602kHz	9kHz	+450kHz	9kHz				
E, T	E3 RDS	FM	87.5MHz-108.0MHz	50kHz	+10.7MHz	25kHz	0	1	0	1
		AM	531kHz-1602kHz	9kHz	+450kHz	9kHz				
Y, M, I, C, V	M	K2/E1 are switched by DSW1. (DSW1 = 1:K2type, 0: E1type)					0	0	X	1

※1 DIODE SW(DSWx) : 0 = NO DIOE(1 = WITH DIODE
X = TRANSISTOR SW(0=OFF/1=ON)

3. Conditions according to the models or destination

3-1 Distinction of Destination : u-com (X13,IC3) Port 54

Type	Voltage : Max 5.0V
K2	0~0.52
K1	1.61~2.49
K4(RBDS)	2.51~3.39
E3(RDS)	3.41~4.45
E1	4.47~5.00

3-2 Distinction of Models : u-com (X13,IC3) Port 53

Models	*	Voltage : Max 5.0V
VR-5080	NO	0~0.37
VR-5090	YES	0.39~1.10
VR-5700	YES	1.12~1.84
VR-5900-S	YES	1.86~2.49
KRF-X9995D/D-S	YES	2.51~3.14
KRF-X7775D/D-S	YES	3.16~3.88
KRF-X9995D-S (M/X TYPE)	NO	3.90~4.61
KRF-X7775D-S (M/X/V TYPE)	NO	4.63~5.00

* Switching of RF or Front IR and Rear IR Receiver Terminal.

4. Tuner Preset Memory

P.ch	K1	K2	K4	E1	E3	P.ch	K1	K2	K4	E1	E3
1	FM 98.3M	FM 98.3M	FM 98.3M	FM 98.3M	FM 98.3M	21	AM 530K	AM 530K	AM 530K	AM 531K	AM 531K
2	FM 87.5M	FM 87.5M	FM 87.5M	FM 87.5M	FM 87.5M	22	FM 87.5M	FM 87.5M	FM 87.5M	FM 87.5M	FM 87.5M
3	FM 89.1M	FM 89.1M	FM 89.1M	FM 89.1M	FM 89.1M	23	FM 87.5M	FM 87.5M	FM 87.5M	FM 87.5M	FM 87.5M
4	FM 108.0M	FM 108.0M	FM 108.0M	FM 108.0M	FM 108.0M	24	FM 87.5M	FM 87.5M	FM 87.5M	FM 87.5M	FM 87.5M
5	FM 90.0M	FM 90.0M	FM 90.0M	FM 90.0M	FM 90.0M	25	FM 87.5M	FM 87.5M	FM 87.5M	FM 87.5M	FM 87.5M
6	FM 87.5M	FM 87.5M	FM 87.5M	FM 87.5M	FM 87.5M	26	FM 87.5M	FM 87.5M	FM 87.5M	FM 87.5M	FM 87.5M
7	FM 87.5M	FM 87.5M	FM 87.5M	FM 87.5M	FM 87.5M	27	FM 87.5M	FM 87.5M	FM 87.5M	FM 87.5M	FM 87.5M
8	AM 1610K	FM 87.5M	AM 1610K	FM 87.5M	FM 87.5M	28	FM 87.5M	FM 87.5M	FM 87.5M	FM 87.5M	FM 87.5M
9	AM 1700K	AM 1610K	AM 1700K	AM 1602K	AM 1602K	29	FM 87.5M	FM 87.5M	FM 87.5M	FM 87.5M	FM 87.5M
10	AM 1000K	AM 1000K	AM 1000K	AM 999K	AM 999K	30	FM 106.0M	FM 106.0M	FM 106.0M	FM 106.0M	FM 106.0M
11	AM 630K	AM 630K	AM 630K	AM 630K	AM 630K	31	FM 87.5M	FM 87.5M	FM 87.5M	FM 87.5M	FM 87.5M
12	AM 1440K	AM 1440K	AM 1440K	AM 1440K	AM 1440K	32	FM 87.5M	FM 87.5M	FM 87.5M	FM 87.5M	FM 87.5M
13	FM 106.0M	FM 106.0M	FM 106.0M	FM 106.0M	FM 106.0M	33	FM 87.5M	FM 87.5M	FM 87.5M	FM 87.5M	FM 87.5M
14	AM 530K	AM 530K	AM 530K	AM 531K	AM 531K	34	FM 87.5M	FM 87.5M	FM 87.5M	FM 87.5M	FM 87.5M
15	FM 87.5M	FM 87.5M	FM 87.5M	FM 87.5M	FM 87.5M	35	FM 87.5M	FM 87.5M	FM 87.5M	FM 87.5M	FM 87.5M
16	FM 98.0M	FM 98.0M	FM 98.0M	FM 98.0M	FM 98.0M	36	FM 87.5M	FM 87.5M	FM 87.5M	FM 87.5M	FM 87.5M
17	FM 98.5M	FM 98.5M	FM 98.5M	FM 98.5M	FM 98.5M	37	FM 87.5M	FM 87.5M	FM 87.5M	FM 87.5M	FM 87.5M
18	FM 87.5M	FM 87.5M	FM 87.5M	FM 87.5M	FM 87.5M	38	FM 87.5M	FM 87.5M	FM 87.5M	FM 87.5M	FM 87.5M
19	AM 990K	AM 990K	AM 990K	AM 990K	AM 990K	39	FM 108.0M	FM 108.0M	FM 108.0M	FM 108.0M	FM 108.0M
20	FM 97.4M	FM 97.4M	FM 97.4M	FM 97.7M	FM 97.7M	40	AM 1000K	AM 1000K	AM 1000K	AM 945K	AM 945K

CIRCUIT DESCRIPTION

5. Test Mode

5-1 Setting Method of the Test Mode

•Turn on the power supply while pressing the "INPUT SELECTOR DOWN" key, to make a set in test mode.

5-2 Canceling the Test Mode

•The system is initialized and the test mode is cancelled if unplug the AC power cord from an AC power wall outlet.

5-3 Contents of the Test Mode

* The following operation is available when the FL is all lighting up mode only.

Key	Operation	Display
SOUND	Set up the RF frequency to 428MHz.	RF BAND
LISTEN MODE	Set up the RF frequency to 422MHz.	RF BAND
THX	Indicated the tuner destination in the FL.	EX. TYPE E1
MEMORY	Changed the dimmer off/1/2 cyclically.	ALL FL Light ON

6. Main Microcomputer: uPD784217A518 (X13, IC3)

6-1 Main Microcomputer Periphery block diagram

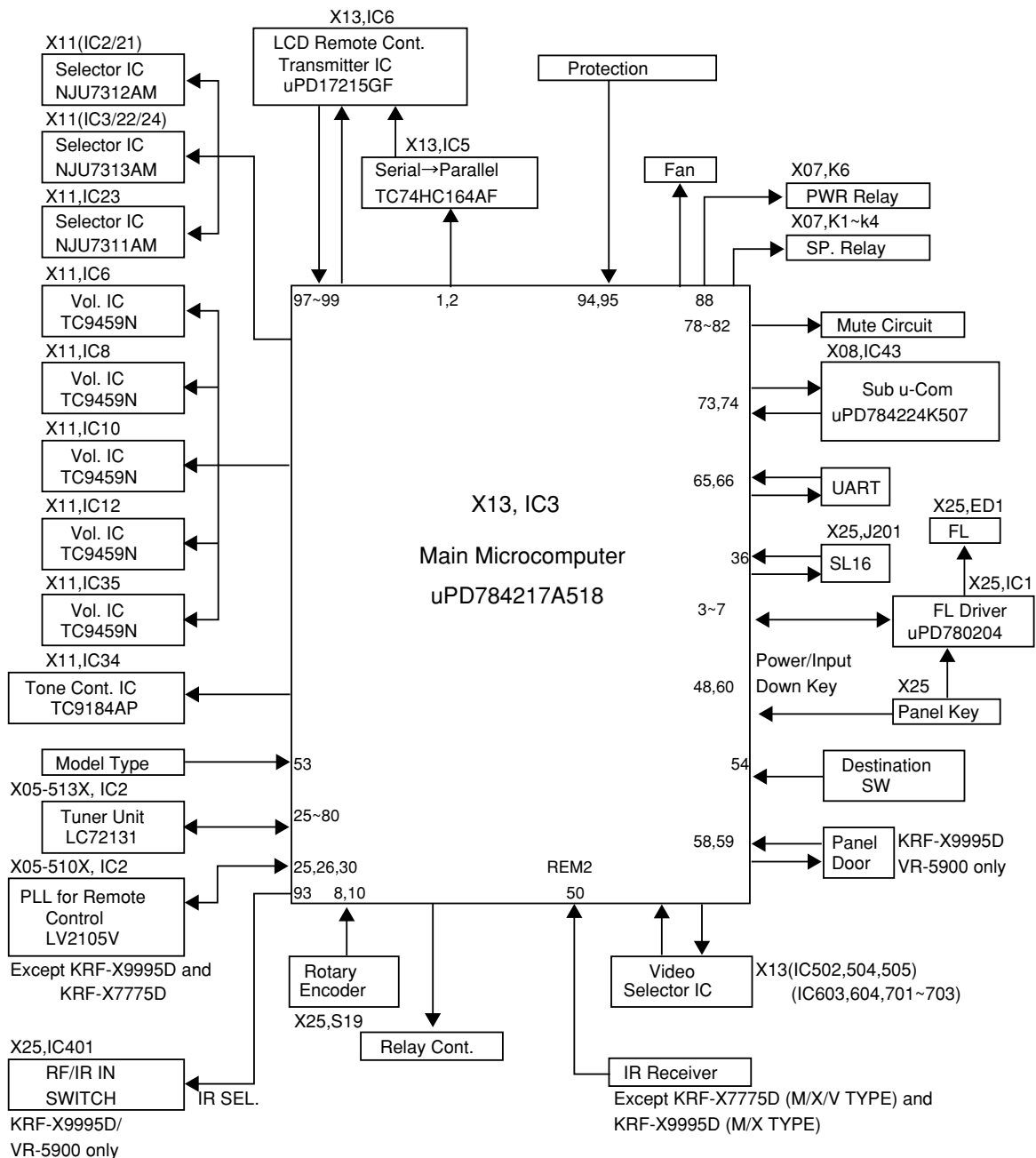

CIRCUIT DESCRIPTION

6-2 Port Description of Main Microcomputer : uPD784217A518 (X13, IC3)

Port No.	Port Name	I/O	Function
1	REM DA	O	IR transmitter IC(X13,IC5) control data output.
2	REM CK	O	IR transmitter IC(X13,IC5) control clock output.
3	FL CLK	O	Clock output to FL driver.
4	FL DIN	I	Data input from FL driver.
5	FL DOUT	O	Data output to FL driver.
6	FL STB	O	Strobe output to FL driver.
7	FL RST	O	Reset output to FL driver.
8	ENC B	I	Input port of volume encoder.
9	VDD	-	+5V power supply.
10	ENC A	I	Input port of volume encoder.
11	SEL CLK	O	Clock output to selector IC.
12	SEL DATA	O	Data output to selector IC.
13~15	SEL STB1~3	O	Strobe (1~3) output to selector IC.
16	TONE CLK	O	Clock output to tone control / selector IC.
17	TONE DATA	O	Data output to tone control / selector IC.
18	TONE STB	O	Strobe output to tone control IC.
19	VOL CLK	O	Clock output to volume IC.
20	VOL DATA	O	Data output to volume IC.
21	VOL STB2	O	Strobe 2 output to volume IC.
22	TEST/VPP	-	Connected to GND.
23	STEREO	I	Tuner stereo signal detection port.
24	SD	I	Tuner SD signal detection port.
25	RF PLL CLK	O	Clock output to PLL (LC72131) IC. * Clock output to PLL IC (LV2105V) for RF remote controller. * Except KRF-X7775D/9995D
26	RF PLL DATA	O	Data output to PLL(LC72131) IC. * Data output to PLL IC (LV2105V) for RF remote controller. * Except KRF-X7775D/9995D
27	PLL DO	I	Data input from PLL (LC72131)IC.
28	PLL CE	O	Chip enable to PLL (LC72131) IC.
29	T MUTE	O	Mute control to tuner.
30	RF PLL CE	O	PLL (LV2105V)CE for RF remote controller. (VR series only)
31~33	P MACRO A~C	O	Output port for perfect macro (A~C). (Refer to 7-6)
34	TV SENS	I	Detection port of TV signal. (Refer to 7-7)
35	VOL STB1	O	Strobe 1 output to volume IC.
36	S DATA	I/O	SL16 data input/output.
37	VDD	-	+5V power supply
38	X2	-	Crystal resonator (12.5MHz) connection.
39	X1	-	Crystal resonator (12.5MHz) connection.
40	VSS	-	Connected to GND.
41	XT2	-	Unused.
42	XT1	-	Unused.
43	RESET	I	Reset signal input for main microcomputer.
44	CE	I	Detection port of chip enable.
45	S BUSY	I/O	Busy signal input/output.
46	232C DET	I	Detection port of RS232C communication. (Except KRF-X7775D)
47	RDS CLK	I	Clock input of RDS demodulator IC. (E/T type only)
48	POWER KEY IN	I	Detection port for power key.
49	REM1	I	Remote control signal input 1 (front panel).
50	REM2	I	Remote control signal input 2 (IR receiver). Except KRF-X7775D (X/M/V)and KRF-X9995D (M/X)

CIRCUIT DESCRIPTION

Port No.	Port Name	I/O	Function
51	VDD	-	+5V power supply
52	AVREF	-	Reference voltage input.
53	MODEL SEL	I	Discrimination port for model type.
54	DSW0	I	Detection port for tuner destination SW 0.
55	THERM SW	I	Detection port for thermal switch. (Refer to 7-1)
56	S LEVEL	I	RDS signal level input. (E/T type only)
57	RDS DATA	I	Data input of RDS demodulator IC. (E/T type only)
58	CLOSE SENS	I	Detection port of close sensor for panel door. (Refer to 7-3) (KRF-X9995D/VR-5900 only)
59	OPEN SENS	I	Detection port of open sensor for panel door. (Refer to 7-3) (KRF-X9995D/VR5900 only)
60	INPUT DOWN KEY IN	I	Detection port of input down key.
61	AVSS	-	Connected to GND.
62	P MACRO IN	I	Input port of perfect macro. (Refer to 7-7)
63	RELAY CONT	O	Relay control output. (Refer to 7-4)
64	AVREF1	-	Reference voltage input.
65	1394/TEXT RX	I	CD TEXT UTRA communication data input.
66	1394/TEXT TX	O	CD TEXT UTRA communication data output.
67	SUB RESET	O	Reset signal output to sub microcomputer.
68	RS RX1	I	RS232C communication data input 1. (Except KRF-X7775D)
69	RS TX1	O	RS232C communication data output 1. (Ditto)
70	RS RX2	I	RS232C communication data input 2. (Ditto)
71	RS TX2	O	RS232C communication data output 2. (Ditto)
72	LED	O	Control port for pro logic2 led.
73	SDT	I	Communication data input from sub microcomputer.
74	MDT	O	Communication data output to sub microcomputer.
75	MCK	O	Clock output to sub microcomputer.
76	MREQ	O	Communication master request.
77	SREQ	I	Communication slave request.
78	F/CSW MUTE	O	Mute control port for room A.
79	PRE S/B MUTE	O	Mute control port for pre out surround.
80	SP S/B MUTE	O	Mute control port for S/B speakers.
81	PRE ZB MUTE	O	Mute control port for pre out B (zone B).
82	V/RECMUTE	O	Mute control port for video rec out.
83	10dB GAIN	O	Switching port for +10dB amplifier.
84	RELAY CS	O	Mute control port for center/surround speakers.
85	RELAY B	O	Relay control port for speaker B.
86	RELAY A	O	Relay control port for speaker A.
87	RELAY TR	O	Switching port for transformer tap.
88	POWER	O	Power relay control port.
* 89	FAN H/L	O	Control port for fan motor (H/L).
* 90	FAN ON/OFF	O	Control port for fan motor (on/off).
* 91	10W	I	10W detection port for fan control.
* 92	1W	I	1W detection port for fan control.
93	IR SELECT	O	RF/IR IN switch control. (Refer to 7-5), KRF-X9995D/VR-5900 only
94	V PROT	I	Detection port of protection signal.
95	I PROT	I	Detection port of protection signal.
96	STBY LED	O	Control port for standby led.
97	REM RWR	I	RWR from LCD remote controller.
98	REM ENB	I	Chip enable from LCD remote controller.
99	REM REQ	O	Request to LCD remote controller.
100	VSS	-	GND

* Refer to 7-1

CIRCUIT DESCRIPTION

7. Description of the Circuit Control

7-1 Fan Control (X13,IC3)

Fan	10W(91Pin)	1W(92Pin)	THERMAL SW(55Pin)	FAN ON/OFF(90Pin)	FAN H/L(89Pin)
FAN STOP	H	H	L	0	1
FAN LOW SPEED	H	L	L	1	1
FAN HI SPEED	L	L	L	1	0
FAN LOW SPEED	H	H	H	1	1
	H	L	H	1	1
FAN HI SPEED	L	L	H	1	0

7-2 Door Open/Close Control : FL Driver(X25,IC1)

KRF-X9995D/VR-5900 only

	DOOR OUT1(42Pin)	DOOR OUT2(41Pin)
OPEN	1	0
CLOSE	0	1
STOP	0	0
BREAK	1	1

7-3 Open Close Sensor(X13,IC3 : Main u-com)

KRF-X9995D/VR-5900 only

	OPEN SENS(59Pin)	CLOSE SENS(58Pin)
END OF OPEN ACTION	0	1
END OF CLOSE ACTION	1	0

7-4 Relay Control : X13,IC3(Main u-com)

SELECTOR	RELAY CONT.(63Pin)
PHONO	0
TUNER	
CD1	
MD/TAPE1	
CD-R	
CD2/TAPE2 MONITOR	1
VIDEO1	
VIDEO2	
VIDEO3	
VIDEO4	
DVD	
AV/AUX	

7-5 IR Remote Control

		X25,IC401 RF IN (7Pin)	X25,IC401 IR IN (6Pin)	IR SELECT X13,IC3 (93Pin)
WITH RF VERSION	RF ON	X	O	0
	RF OFF	O	X	1
WITHOUT RF VERSION	FRONT IR ON	X	O	0
	FRONT IR OFF	O	X	1

7-6 P Macro Video Switch(X13,IC505)

SELECTOR	P MACRO A(3Pin)	P Macro B(4Pin)	P Macro C(5Pin)
VIDEO1	0	0	0
VIDEO2	0	1	0
VIDEO3	1	0	0
VIDEO4	1	1	0
DVD	0	0	1

7-7 Video/TV Detection : X13,IC3

Video Detection

Video Signal	P Macro IN(62Pin)
Yes	H
No	L

TV Detection

TV POWER	TV SENS.(34Pin)
ON	H
OFF	L

8. Sub microcomputer: uPD784224K507(X08, IC43)

8-1 Sub microcomputerperiphery block diagram

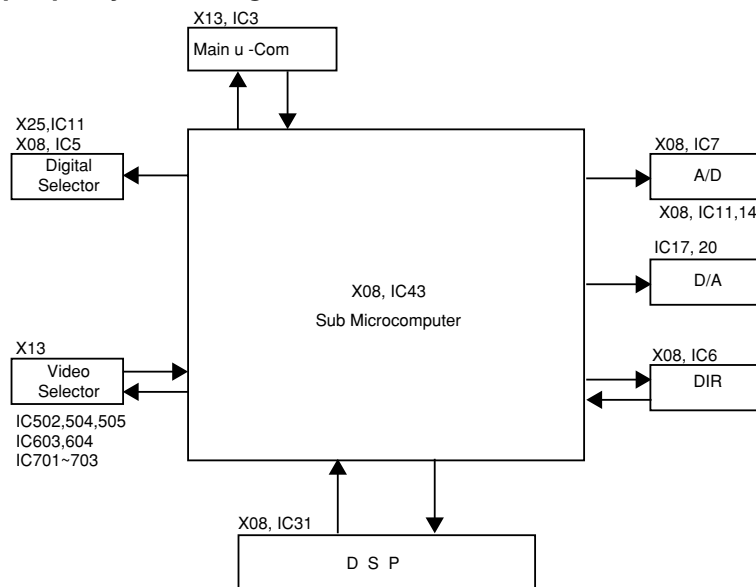

CIRCUIT DESCRIPTION

8-2 Port Description of Sub Microcomputer : uPD784224K506 (X08,IC43)

Port No.	Port Name	I/O	Function	ACTIVE	
				H	L
1	ERF	I	D.I.R. (X08, IC6) error flag.		
2	FS96 DET	I	96KHz fs detection. H : fs>88.1kHz detection		
3	AUTO	I	Non-PCM detection. H : Non-PCM detection		
4	AVSS	-	GND		
5	DIR PD	O	Power down for D.I.R. (X08, IC6). L : DIR power down and reset		
6	DIR CS	O	Chip select for D.I.R. (X08, IC6). L : Chip selection		
7	AVREF	-	Reference voltage.		
8	DIR DIN	I	Data input from D.I.R. (X08, IC6).		
9	DIR DOUT	O	Data output for D.I.R. (X08, IC6).		
10	DIR CLK	O	Clock output for D.I.R. (X08, IC6).		
11	D MUTE	O	Mute signal output for D.I.R. (X08, IC6).		Data mute
12	DAC PD	O	Power down for D/A converter (X08, IC11/14/17/20).		Power down
13	DAC 96K	O	Double speed sampling mode for D/A converter speed mode (X08, IC11/14/17/20). H : Double		
14	DAC MUTE	O	Mute signal output for D/A converter (X08, IC11/14/17/20).	Mute	
15	ADC RST	O	Reset signal output for A/D converter (X08, IC7).		Reset
16	MDT	I	Main microcomputer master data.		
17	SDT	O	Sub microcomputer data output.		
18	MCK	I	Main microcomputer control data clock		
19	MREQ	I	Main microcomputer master request.		
20	SREQ	O	Main microcomputer slave request.		
21	REC 6dB	O	Rec gain control when HDCD +6dB.	+6dB on	
22~24	DSEL A~C	O	Control port for digital input selector (A~C).		
25	DSP POWER	O	Power supply for DSP/DAC/ADC/DIR.		
26	DSP RESET	O	Reset signal output for DSP.		
27~32	DSP D0~D5	I/O	DSP control data.		
33	VSS	-	GND		
34,35	DSP D6,7	I/O	DSP control data.		
36	DSP REQ	O	DSP communication request.		Request
37	DSP ACK	I	Input port of command data reading from DSP.		Ack.
38	DSP BUSY	I	DSP status busy.	Busy	
39	DSP WRT	O	DSP Write	Data write	Data read
40	DTS DET	I	DSP DTS detection.	DTS	
41	PCM ZERO	I	PCM zero data detection.	PCM 0	
42	HDCD DET	I	DSP HDCD sync. Detection.	HDCD	
43	HDCD 6dB DET	I	DSP HDCD +6dB detection. (KPCM)	+6dB	
44	OVER LEVEL	I	DSP over level detection.	Over level	
45	PCM MUTE	O	DSP mute control (PCM).		Fixed
46	DRIVE	O	DSP D.R.I.V.E. /HDCD control (PCM).		D.R.I.V.E/ HDCD ON
47	SUB MUTE	O	Sub microcomputer analog mute.		Mute on
48~50	C ROOMB(C/B/A)	O	Zone B video selector control.		
51,52	YC SEL(B, A)	O	Zone A video selector control.		
53~59	C ROOMA(A~G)	O	Zone A video selector control.		
60	RESET	I	Reset signal input.		
61	YC MUTE	O	Zone A video selector (Y/C) mute control.		
62	FSC CTRL	O	Zone A video selector FSC control.		
63	VSEL	O	Zone A video selector control.		
64	CTRL A2	O	Zone A video selector control A2.		
65	CTRL B	O	Zone A video selector control B.		
66	CTRL A	O	Zone A video selector control A.		

CIRCUIT DESCRIPTION

Port No.	Port Name	I/O	Function	ACTIVE	
				H	L
67	VSS	-	GND		
68	VDD	-	Power supply (+3.3V).		
69	X2	-	Crystal resonator (6MHz) connection.		
70	X1	I	Crystal resonator (6MHz) connection.		
71	TEST	-	Pull down port.		
72	XT2	-	Unused.		
73	XT1	-	GND		
74	VDD	-	Power supply (+3.3V).		
75	AVDD	-	Power supply (+3.3V).		
76	NC	-	Unused.		
77	C DET	I	Zone A component signal detection.		Detection
78	Y DET	I	Zone A S-terminal signal detection.		Detection
79	CK DET	I	Zone A color killer detection.		
80	OPT DET	I	Optical digital input detection.		

9. Description of the Circuit Control

* The number in the () is pin number of sub microcomputer.

9-1 Digital Selector

• VR-5700/5900/5090/KRF-X9995D(for OPT and COAX)

INPUT	DSEL A(Pin22)	DSEL B(Pin23)	DSEL C(Pin24)
CD1	L	H	L
MD/TAPE1	H	H	L
CD-R	L	L	H
VIDEO2	H	L	H
VIDEO3	L	H	H
VIDEO4	H	H	H
DVD	H	L	L
OTHERS	L	L	L

• VR-5080/KRF-X7775D

INPUT	DSEL A (Pin22)	DSEL B (Pin23)	DSEL C (Pin24)
CD1(OPT)	L	H	L
VIDEO2(COAX)	L	H	L
VIDEO3(COAX)	H	H	L
DVD(OPT/COAX)	H	L	L
OTHERS	L	L	L

9-2 Video Selector

(BA7649AF,BA7611AF,BA7612F,BA7613F)

① VSEL

INPUT	VSEL(Pin63)
VIDEO1	L
VIDEO2	L
VIDEO3	L
VIDEO4	L
AV-AUX	L
DVD	H
V MUTE	L

② Y C Select

② -1 Y Detect(Pin78) = H

INPUT	Y C SEL A (Pin52)	Y C SEL B (Pin51)
VIDEO1	L	H
VIDEO2	L	H
VIDEO3	L	H
VIDEO4	L	H
AV-AUX	L	H
DVD	H	L
V MUTE	H	H

③ CTRL A, CTRL A2, CTRL B

③ -1 C Detect(Pin77) = L

VR-5900/5090/KRF-X9995D

② -2 Y Detect(Pin78) = L

INPUT	Y C SEL A (Pin52)	Y C SEL B (Pin51)
VIDEO1	L	L
VIDEO2	L	L
VIDEO3	L	L
VIDEO4	L	L
AV-AUX	L	L
DVD	L	L
V MUTE	H	H

INPUT	CTRL A (Pin66)	CTRL A2 (Pin64)	CTRL B (Pin65)
VIDEO1	L	L	H
VIDEO2	L	L	H
VIDEO3	L	L	L
VIDEO4	L	L	H
AV-AUX	L	L	H
DVD	H	H	L
V MUTE	H	H	H

CIRCUIT DESCRIPTION

③ -2 C Detect(Pin77) = H

- CK DET(Pin79) = L
- VR-5900/5090/KRF-X9995D

INPUT	CTRL A (Pin66)	CTRL A2 (Pin64)	CTRL B (Pin65)
VIDEO1	L	L	H
VIDEO2	L	L	H
VIDEO3	L	L	H
VIDEO4	L	L	H
AV-AUX	L	L	H
DVD	L	L	H
V MUTE	H	H	H

③ -3 CK DET(Pin79) = H

VR-5900/5090/KRF-X9995D

INPUT	CTRL A (Pin66)	CTRL A2 (Pin64)	CTRL B (Pin65)
VIDEO1	L	H	H
VIDEO2	L	H	H
VIDEO3	L	H	H
VIDEO4	L	H	H
AV-AUX	L	H	H
DVD	L	H	H
V MUTE	H	H	H

④ CPST A(Pin53~59)

④ -1 Y Detect(Pin78) = H

INPUT	CPST AA (Pin59)	CPST AB (Pin58)	CPST AC (Pin57)	CPST AD (Pin56)	CPST AE (Pin55)	CPST AF (Pin54)	CPST AG (Pin53)
VIDEO1	L	L	L	L	L	L	L
VIDEO2	H	H	H	H	L	L	L
VIDEO3	L	H	L	L	L	L	L
VIDEO4	L	H	H	L	L	L	L
AV-AUX	H	L	L	L	L	L	L
DVD	L	H	L	L	H	L	L
V MUTE	L	H	L	L	H	H	H

④ -2 Y Detect(Pin78) = L

INPUT	CPST AA (Pin59)	CPST AB (Pin58)	CPST AC (Pin57)	CPST AD (Pin56)	CPST AE (Pin55)	CPST AF (Pin54)	CPST AG (Pin53)
VIDEO1	L	L	L	L	L	L	H
VIDEO2	H	H	H	H	L	L	H
VIDEO3	L	H	L	L	L	L	H
VIDEO4	L	H	H	L	L	L	H
AV-AUX	H	L	L	L	L	L	H
DVD	L	H	L	L	H	H	L
V MUTE	L	H	L	L	H	H	H

⑤ CPST B(Pin48~50)

INPUT	CPST BA (Pin50)	CPST BB (Pin49)	CPST BC (Pin48)
VIDEO1	L	L	L
VIDEO2	L	H	L
VIDEO3	H	L	L
VIDEO4	H	H	L
DVD	L	H	H

10. Key Matrix

* The number in the () is pin number of FL driver (X25,IC1).

* KRF-X9995D/VR-5900 only

Key		
Key 1(Pin26)	INPUT UP	* OPEN/CLOSE
Key 2(Pin27)	AUTO	BAND
Key 3(Pin28)	P. CALL UP	MEMORY
Key 4(Pin29)	P. CALL DOWN	MULTI CONT. UP
Key 5(Pin30)	SOUND/SET UP	MULTI CONT. DOWN
Key 6(Pin31)	LISTEN MODE	THX
Key 7(Pin32)	INPUT MODE	CD2/TAPE2 MONI.
Key 8(Pin33)	SPEAKER A	SPEAKER B

ADJUSTMENT

No.	ITEM	INPUT SETTINGS	OUTPUT SETTINGS	RECEIVER SETTINGS	ALIGNMENT POINTS	ALIGN FOR	FIG.
FM SECTION :		SELECTOR : FM		*Adjust NO.1 and NO.2 repeatedly.			
1	DISCRIMINATOR	(A) 98.0MHz 1kHz, ±40kHz dev. 70dBf (ANT. input)	Connect a DC voltmeter between CN2 ① and CN2 ② (X05)	MONO 98.0MHz	L4 (X05-)	0V	
2	DISTORTION (MONO)	(A) 98.0MHz 1kHz, ±40kHz dev. MONO 70dBf (ANT. input)	(B)	MONO 98.0MHz	L5 (X05-)	Minimum distortion	
3	DISTORTION (STEREO)	(C) 98.0MHz 1kHz, ±40kHz dev. Selector : L or R Pilot : ±6kHz dev. 70dBf (ANT. input)	(B)	AUTO 98.0MHz	IFT(RF FRONT END : A1) (X05-)	Minimum distortion (L or R)	
4	TUNING LEVEL	(A) 98.0MHz MONO 1kHz, ±40kHz dev. 30dBf (ANT. input)	-	MONO 98.0MHz	VR1 (X05-)	Adjust VR1 and stop at the point where ED1 (TUNED) goes on.	
AUDIO SECTION		SPEAKER : A		PREOUT : OFF		PROLOGIC : ON	
<1>	IDLE CURRENT	-	Connect a DC voltmeter across each T.P. CN1(9, 10) FLch CN1(5, 6) Cch CN1(7, 8) FRch CN1(1, 2) SRch CN1(3, 4) SRch X07(A/5)	(FRONT 2ch MODE) Volume: Minimum	VR1(FL) VR2(FR) VR3(SL) VR4(SR) VR5(CENTER) X07(A/5)	Adjust every potentiometer 10 minutes later after turned the power on.	

SYSTEM CONNECTIONS

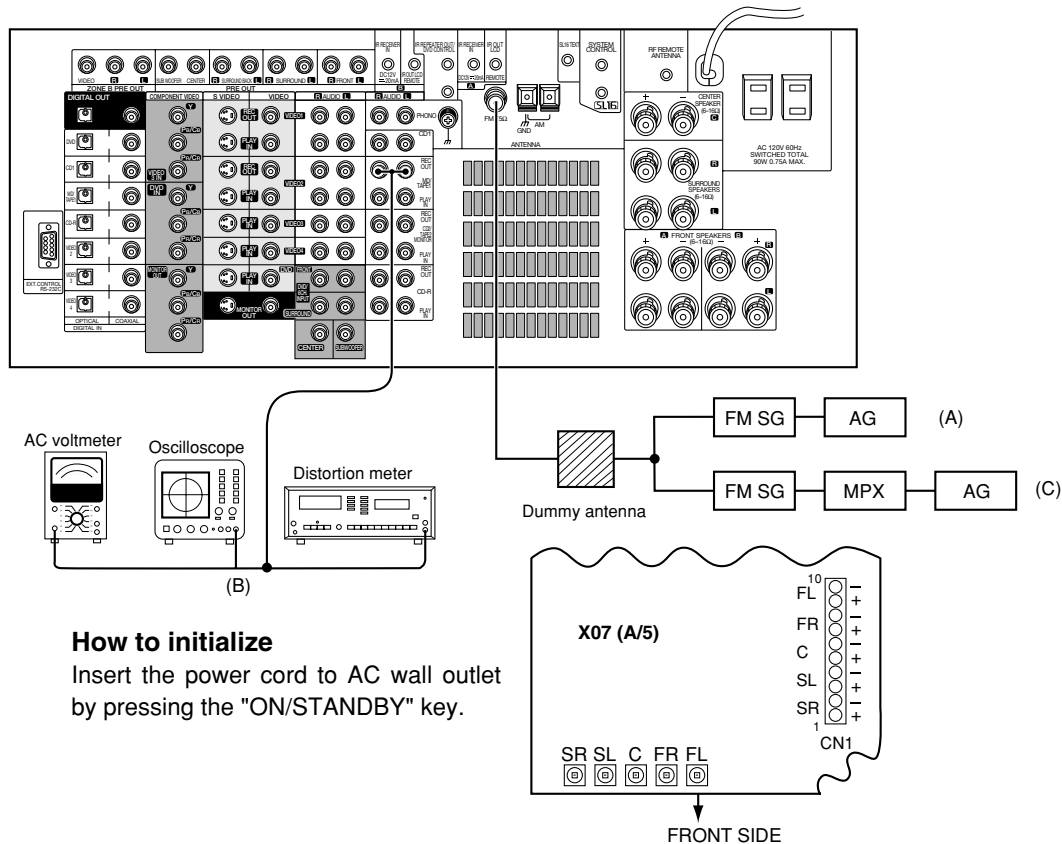

ADJUSTMENT

Adjustment of Sub Color and Contrast (X35, VR1, VR2)

Except KRF-X7775D/VR-5080

No.	ITEM	INPUT SETTINGS	OUTPUT SETTINGS	ALIGNMENT POINTS	ALIGNMENT FOR	FIG.
1	SUB COLOR	PAL 75% COLOR BAR (NO SET UP)	Connect a component video output(Y) to oscilloscope with 75Ω.	VR2	(Adjust an amplitude of video signal.) 0.825Vp - p	FIG.1
2	CONTRAST	PAL 75% COLOR BAR (NO SET UP)	Connect a component video output(Cb,Cr) to oscilloscope with 75Ω.	VR1	(Adjust an amplitude of video signal.) ±0.525Vp - p	FIG.2

INSTRUMENTS CONNECTION

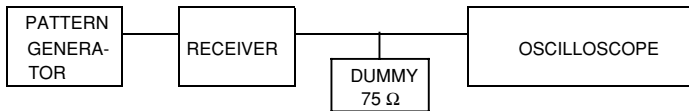

INPUT SIGNAL : 75% COLOR BAR SIGNAL

PARAMETER		WHITE	YELLOW	CYAN	GREEN	MAGENTA	RED	BLUE
LUMINANCE LEVEL	mV	525	465	368	308	217	157	60
	IRE							
CHROMA LEVEL	mV	0	470	664	620	620	664	470
	IRE							
CHROMA PHASE (deg)	+V		167	283	241	61	103	347
	-V		193	77	119	299	257	13

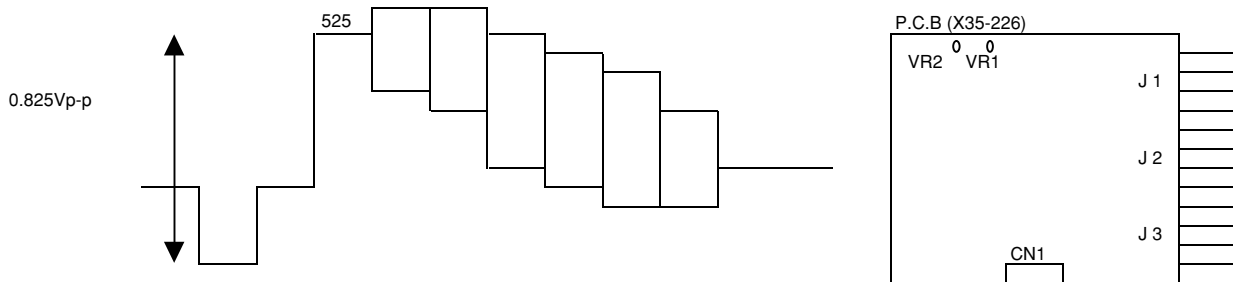

ADJUSTMENT OUTPUT SIGNAL :

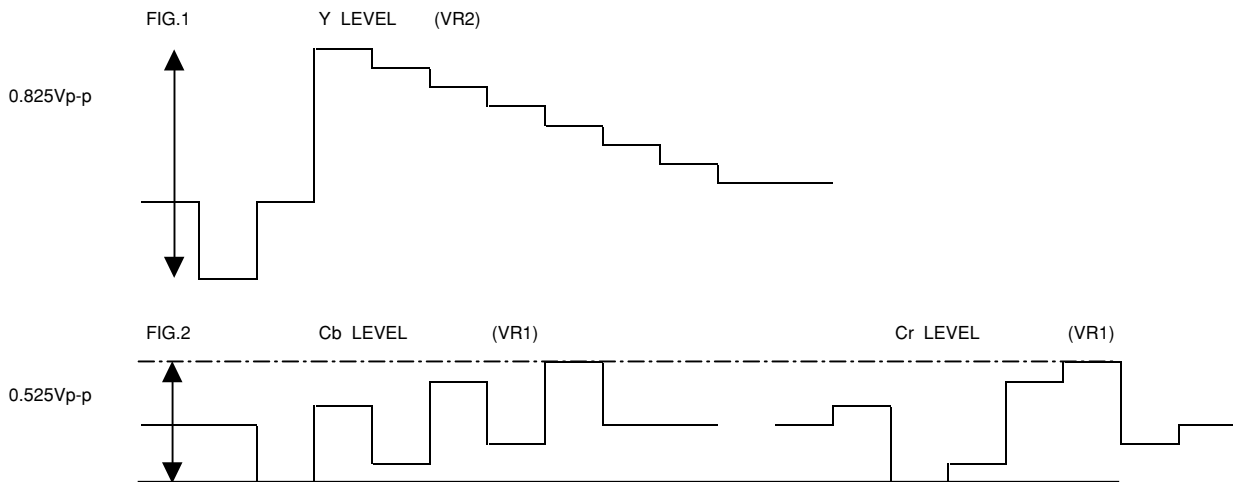

WIRING DIAGRAM

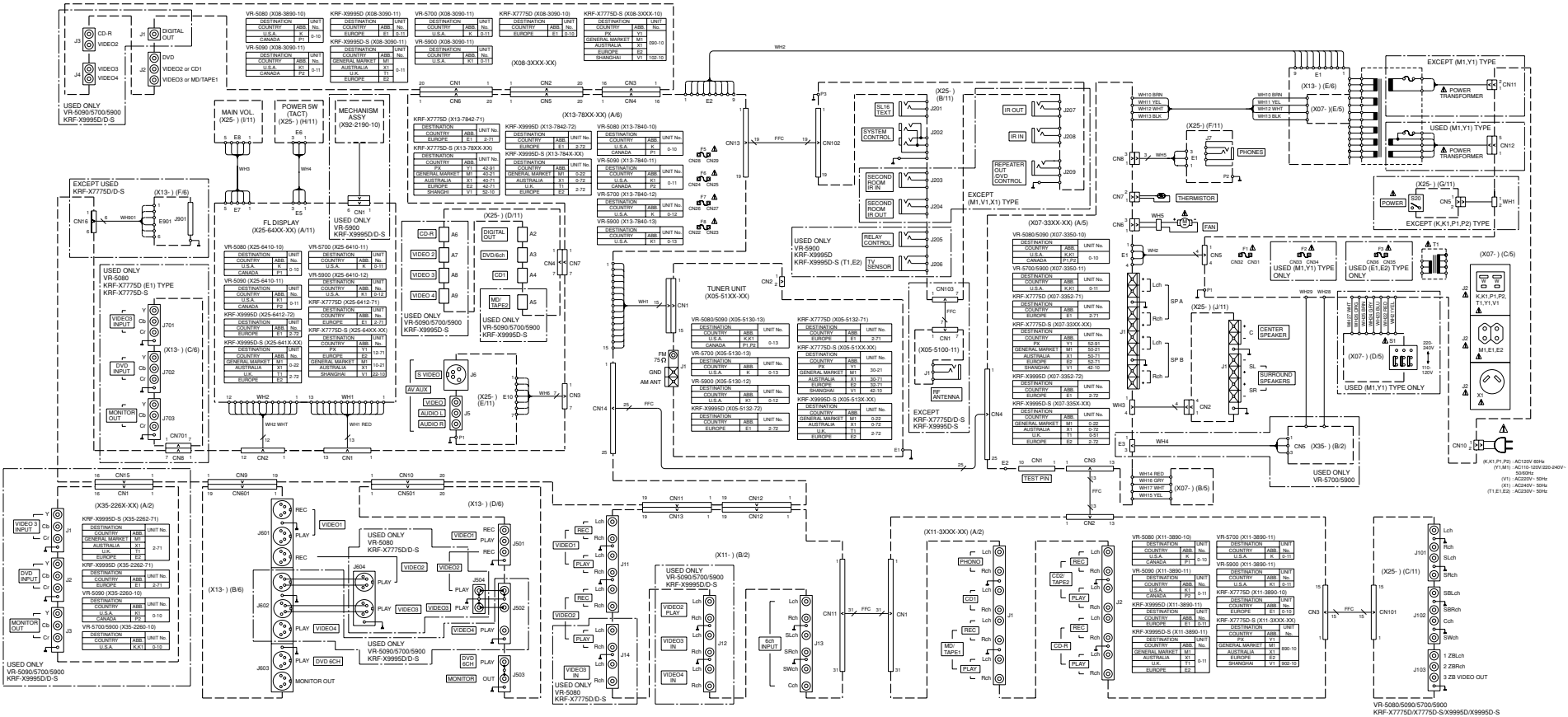

VR-5880/5900/5700/5900 KRF-X7775D/X7775D-S/K9995D/X9995D-S

PC BOARD (Component side view)

X07 C/5

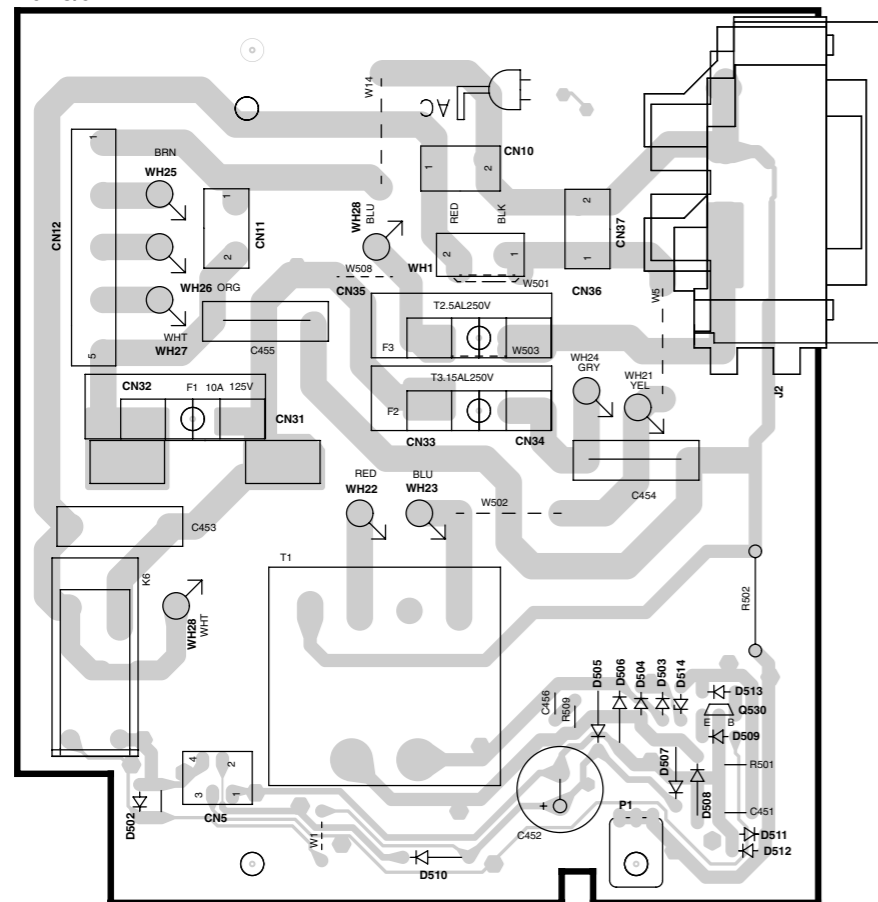

X07 B/5

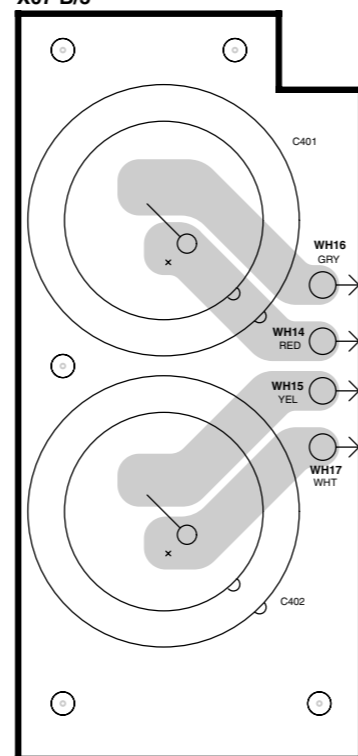

X07-3350-11 A/5 (J70-1481-11)

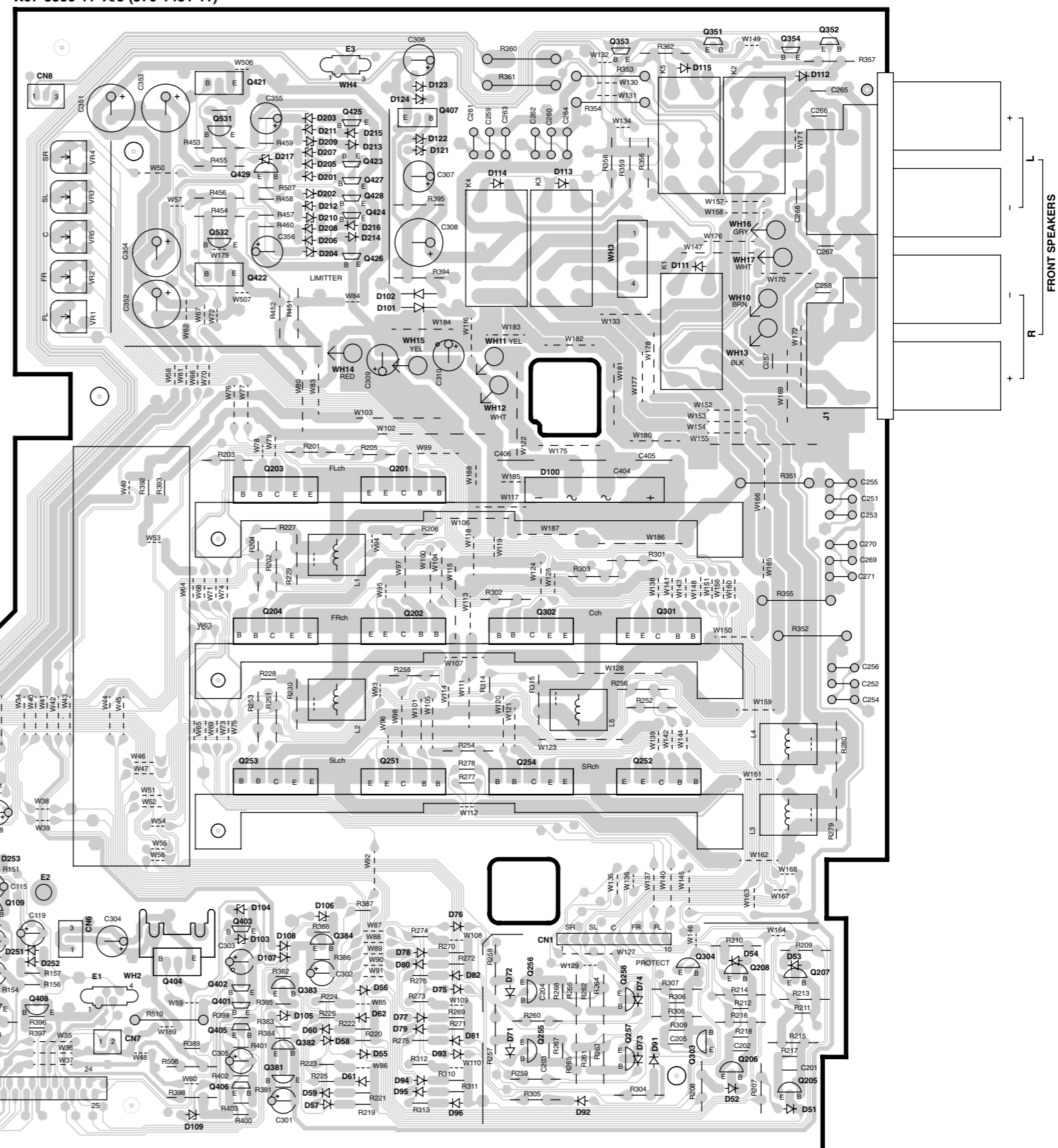

X07 D/5

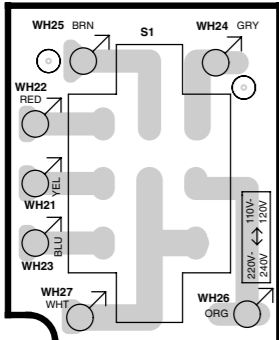

X07 E/5

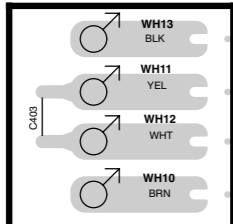

FRONT SPEAKERS

PC BOARD (Component side view)

X08-3090-11 (J70-1482-12)

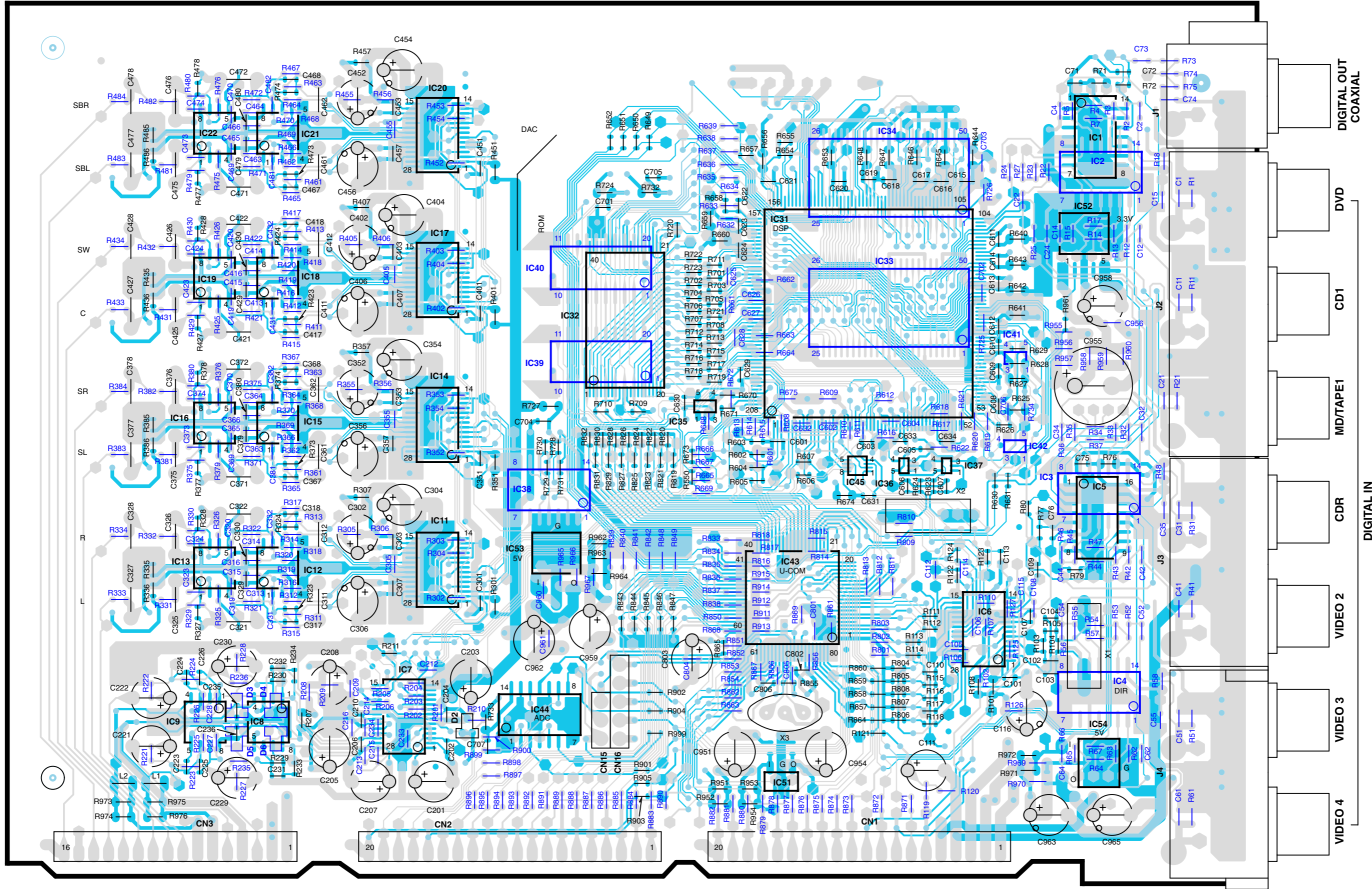

PC BOARD (Component side view)

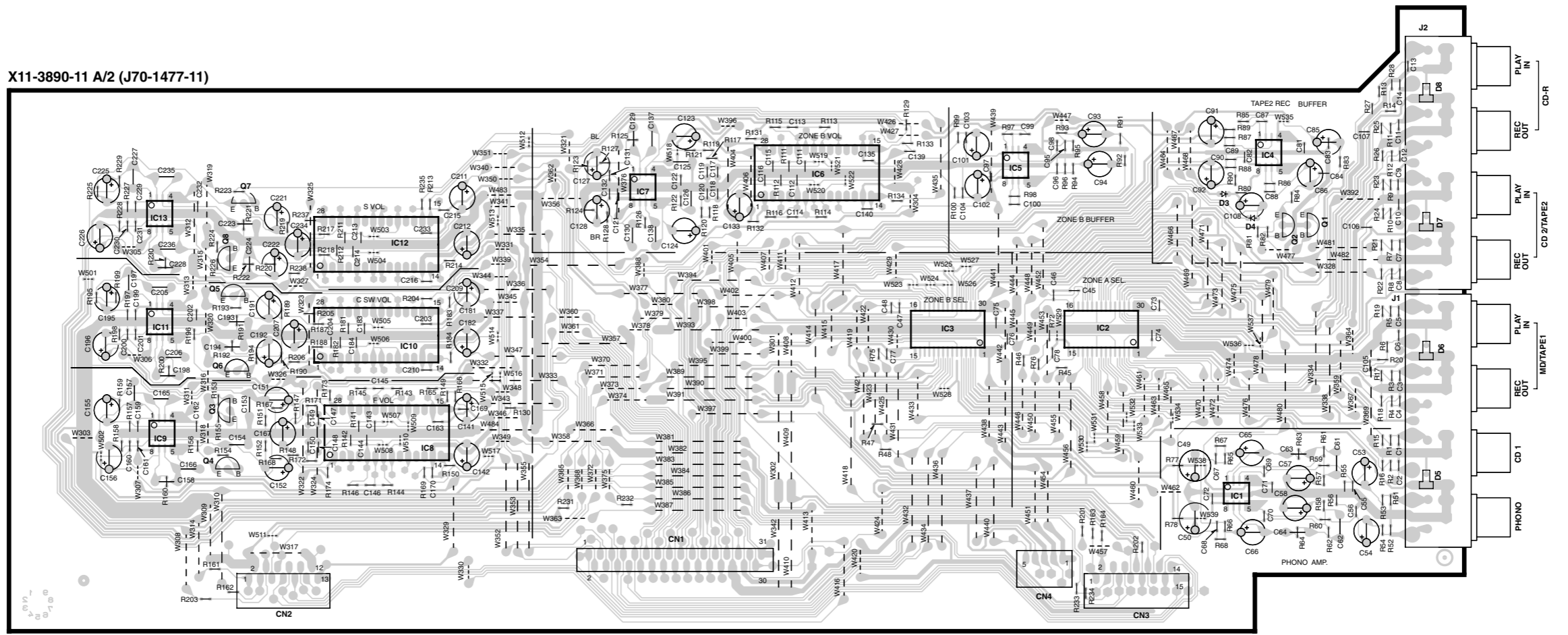
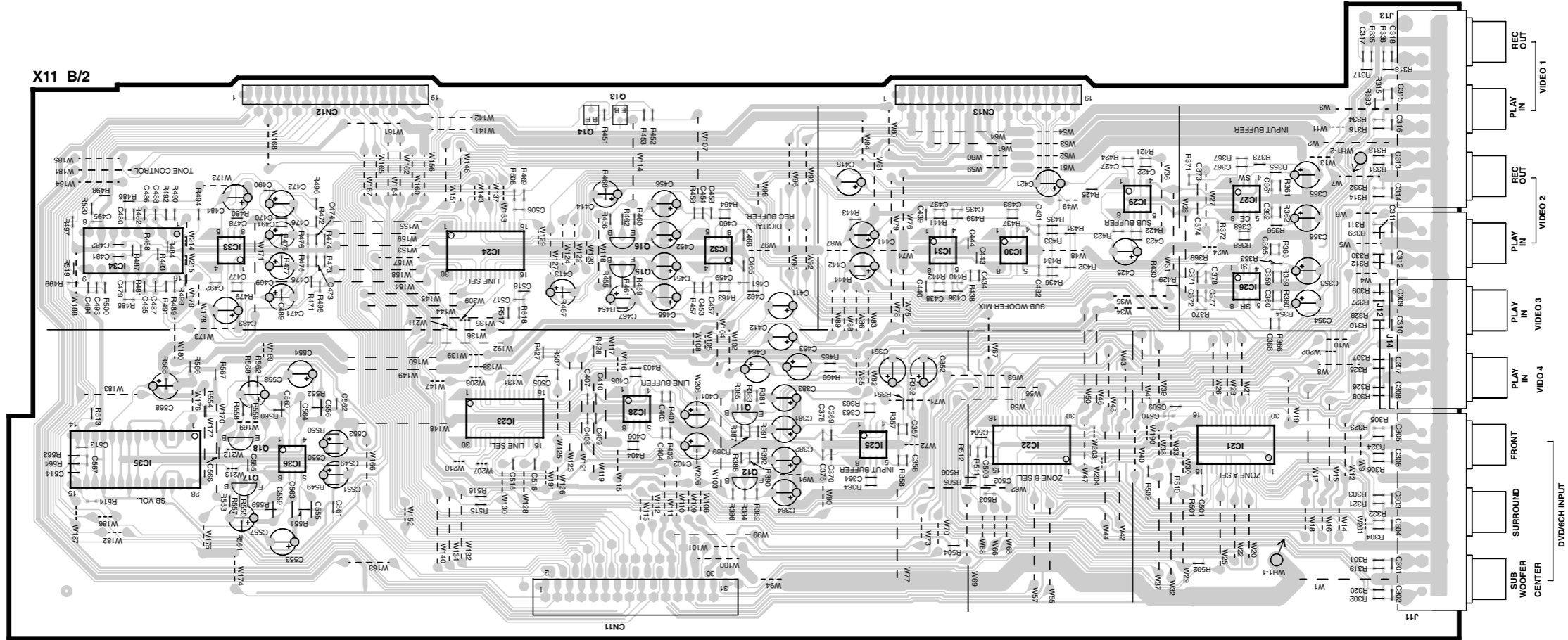

PC BOARD (Component side view)

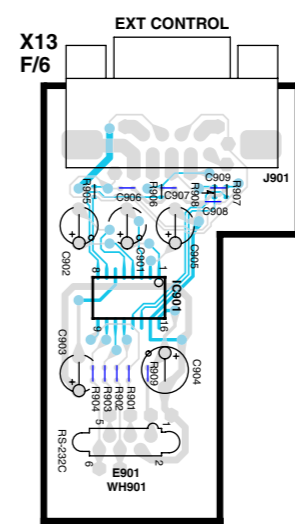
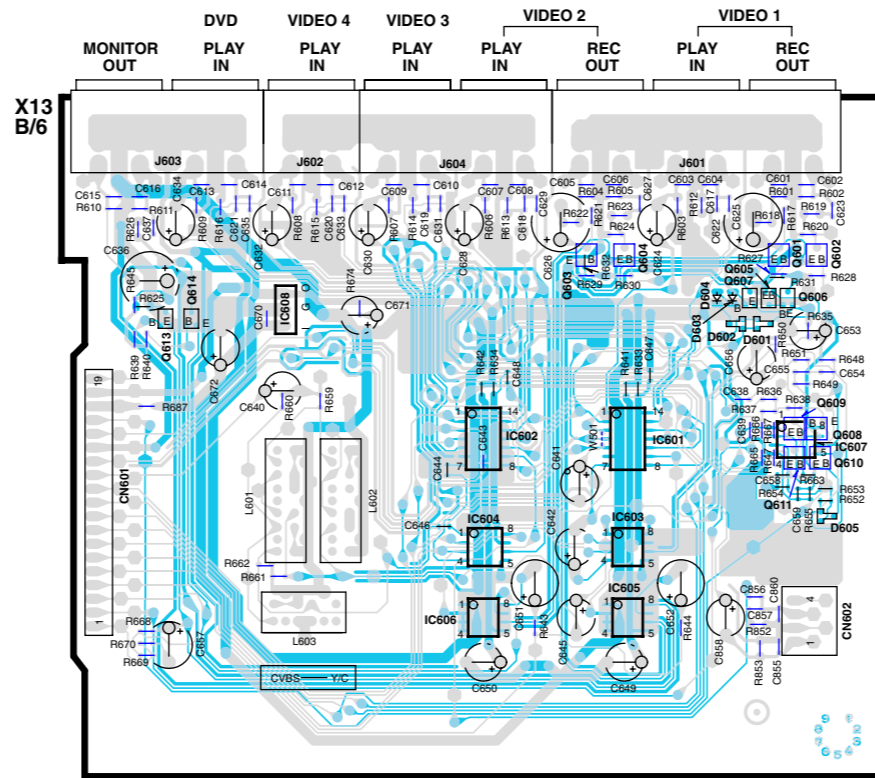
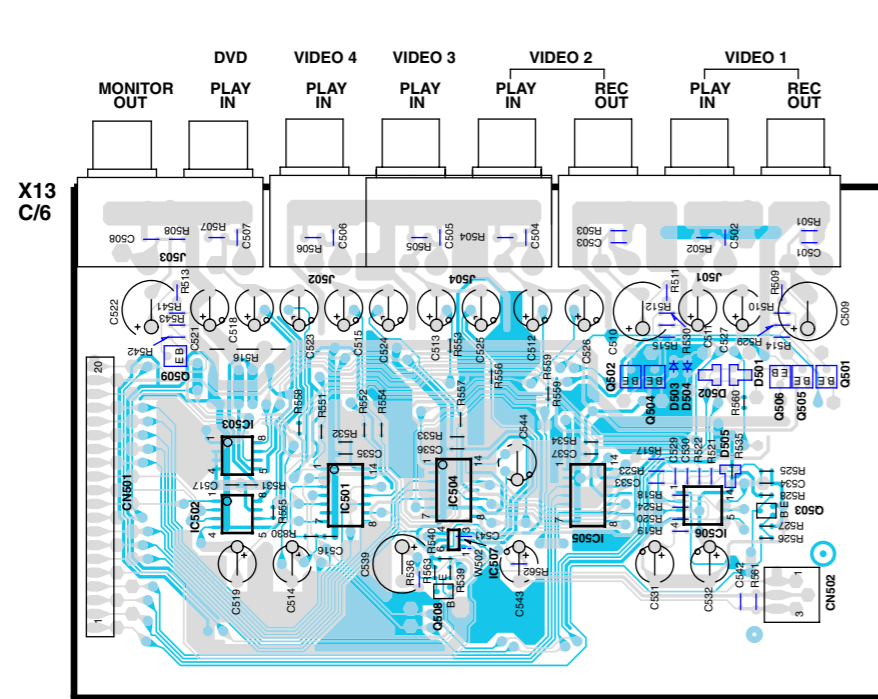

X13-7840-13 A/6 (J70-1472-11)

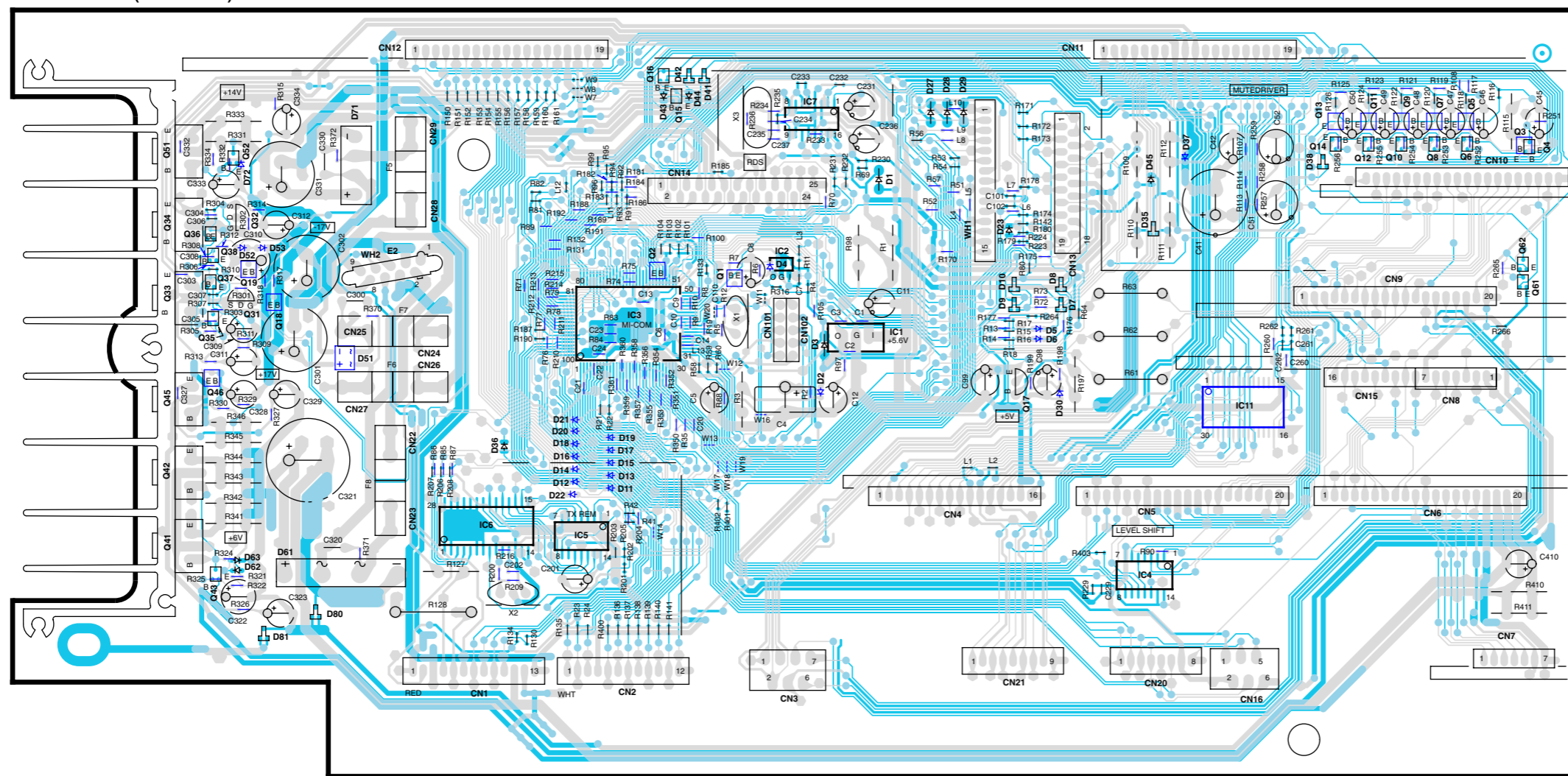

X13 E/6

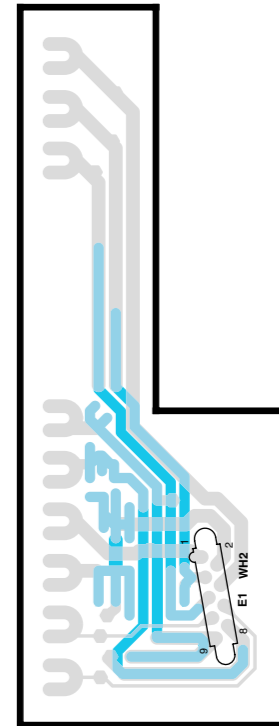

PC BOARD (Component side view)

X25 C/11

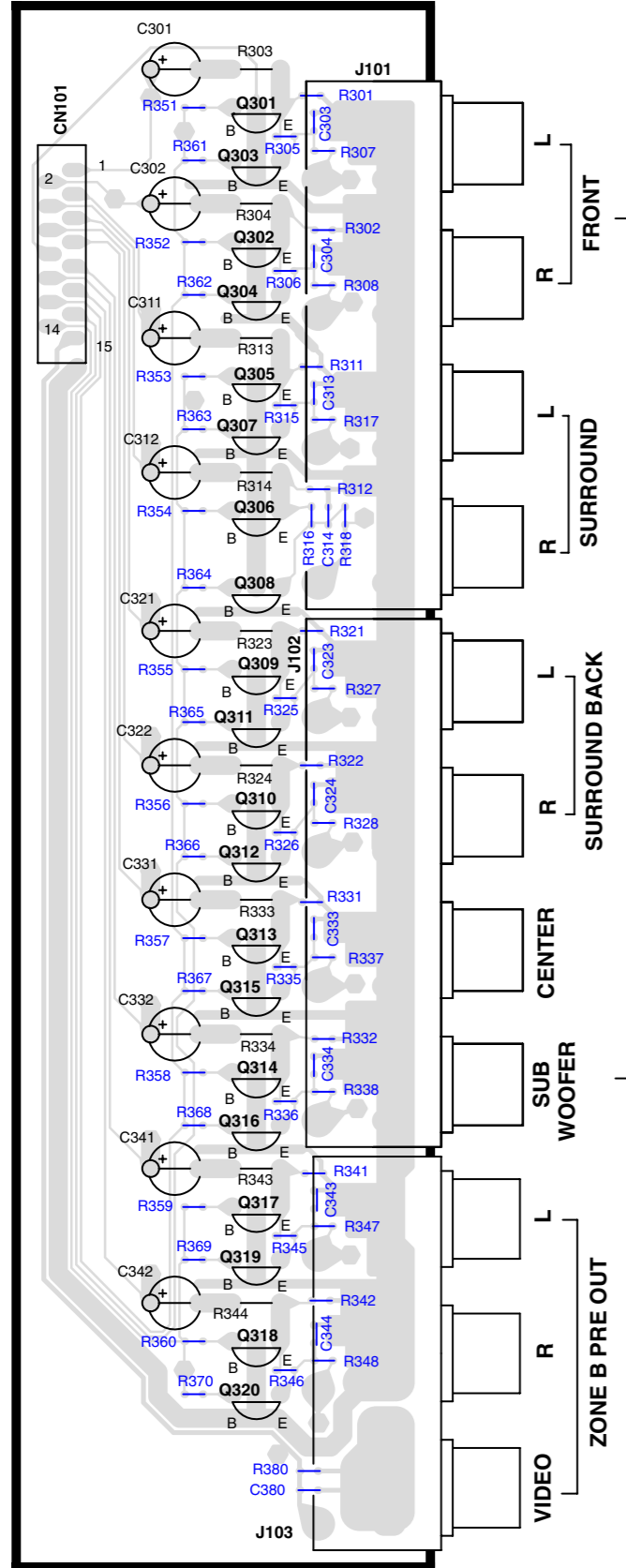

X25 J/11

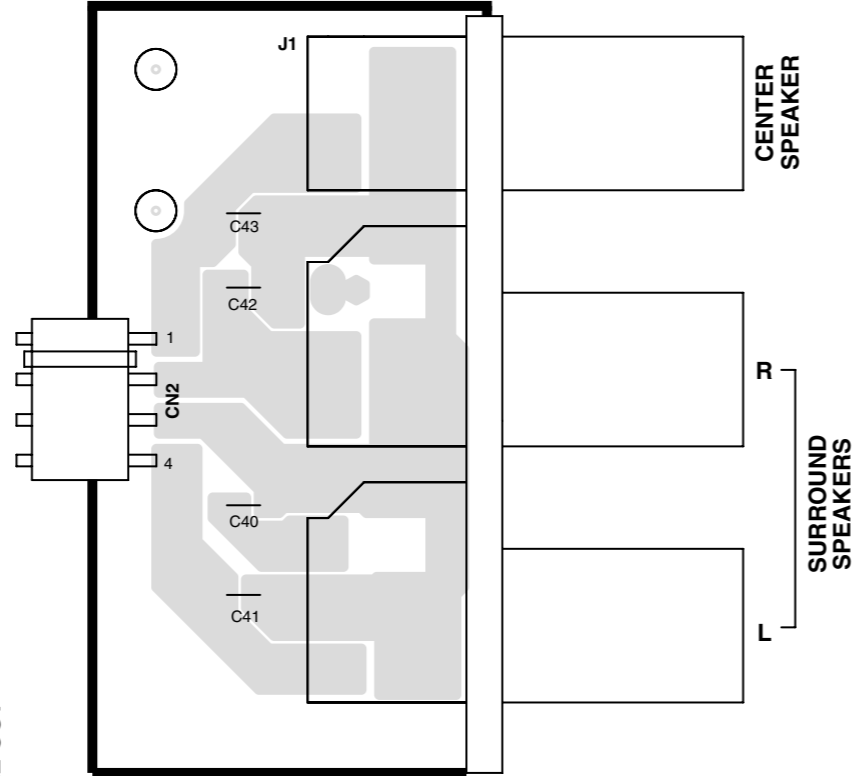

X25 G/11

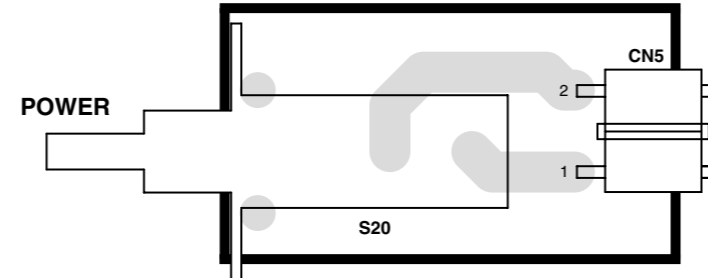

X25 F/11

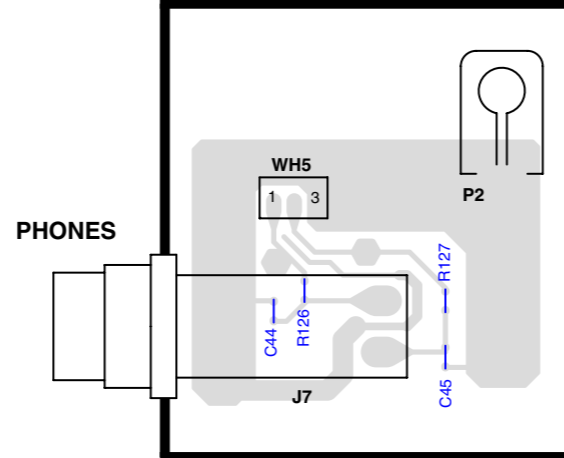

**X35-2260-12 A/2
(J70-1475-11)**

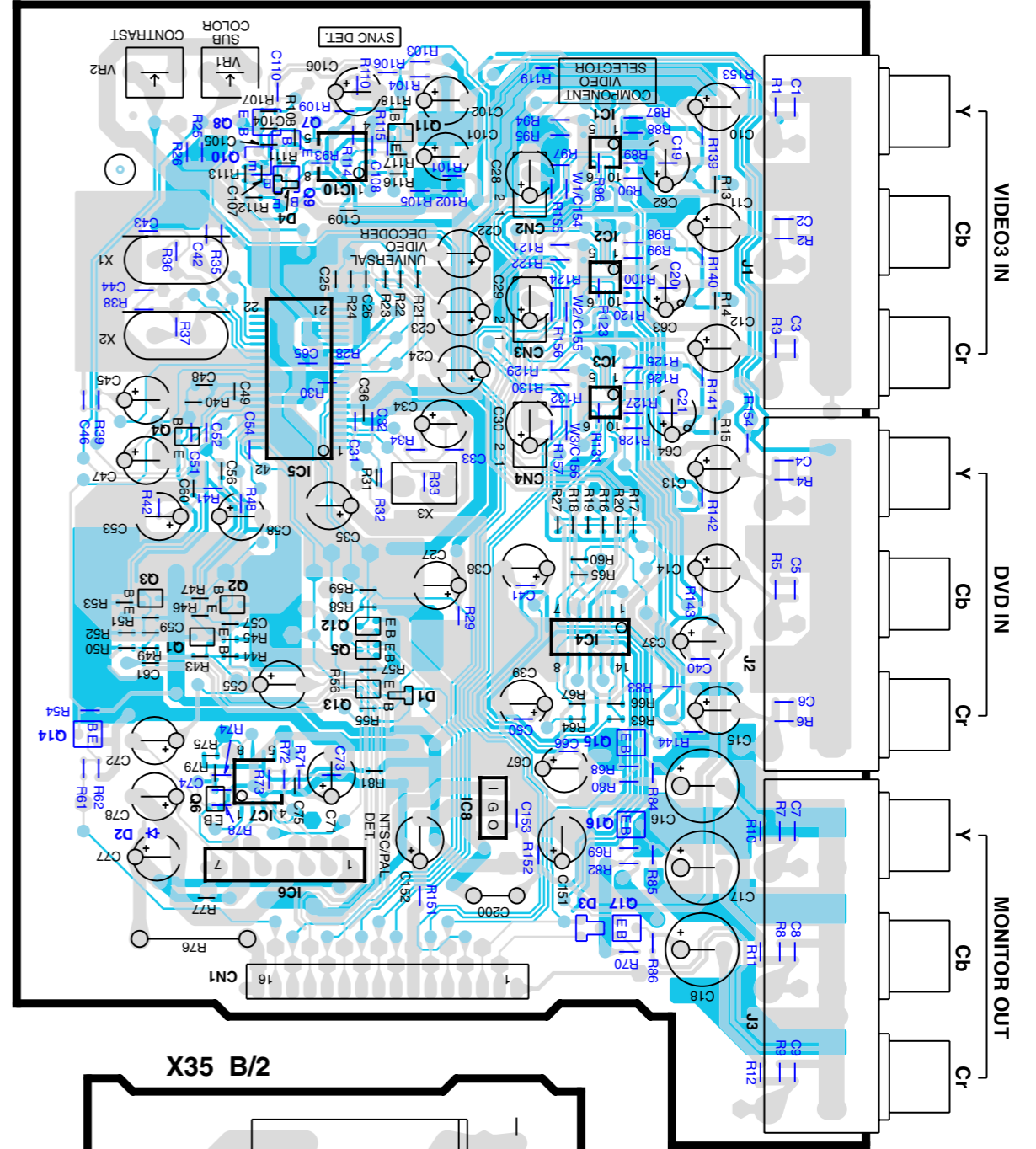

X35 B/2

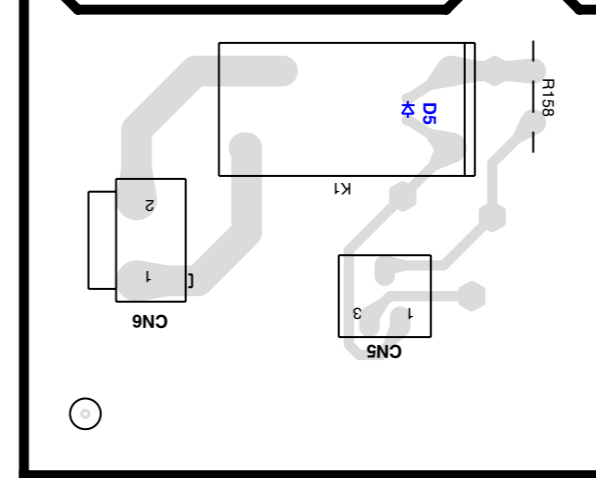

PC BOARD (Component side view)

X05-5130-13 (J70-1381-11)

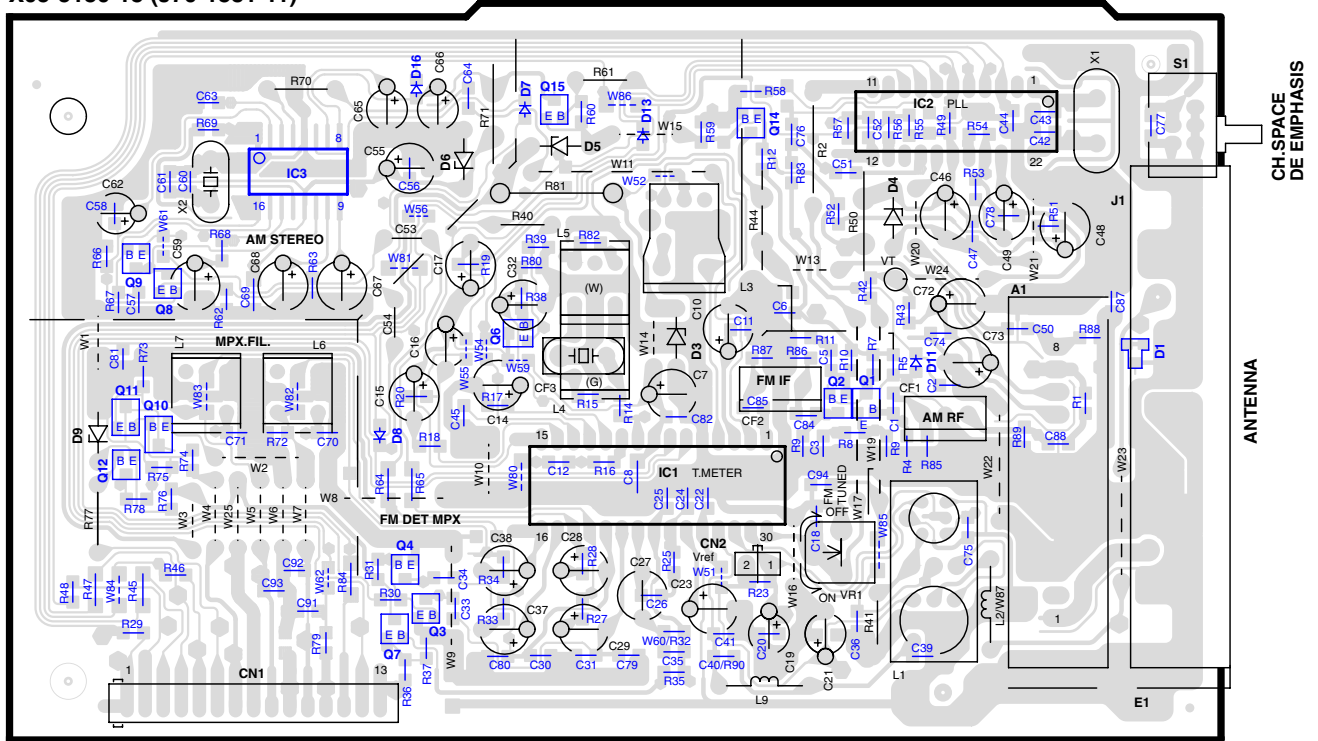

X05-5100-11 (J70-1411-32)

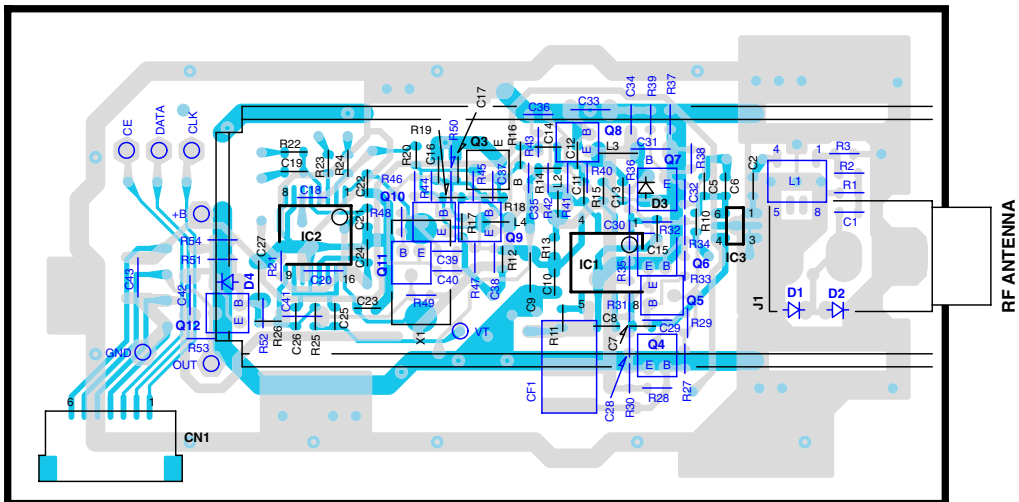

TUNER UNIT (X05-51XX-XX)

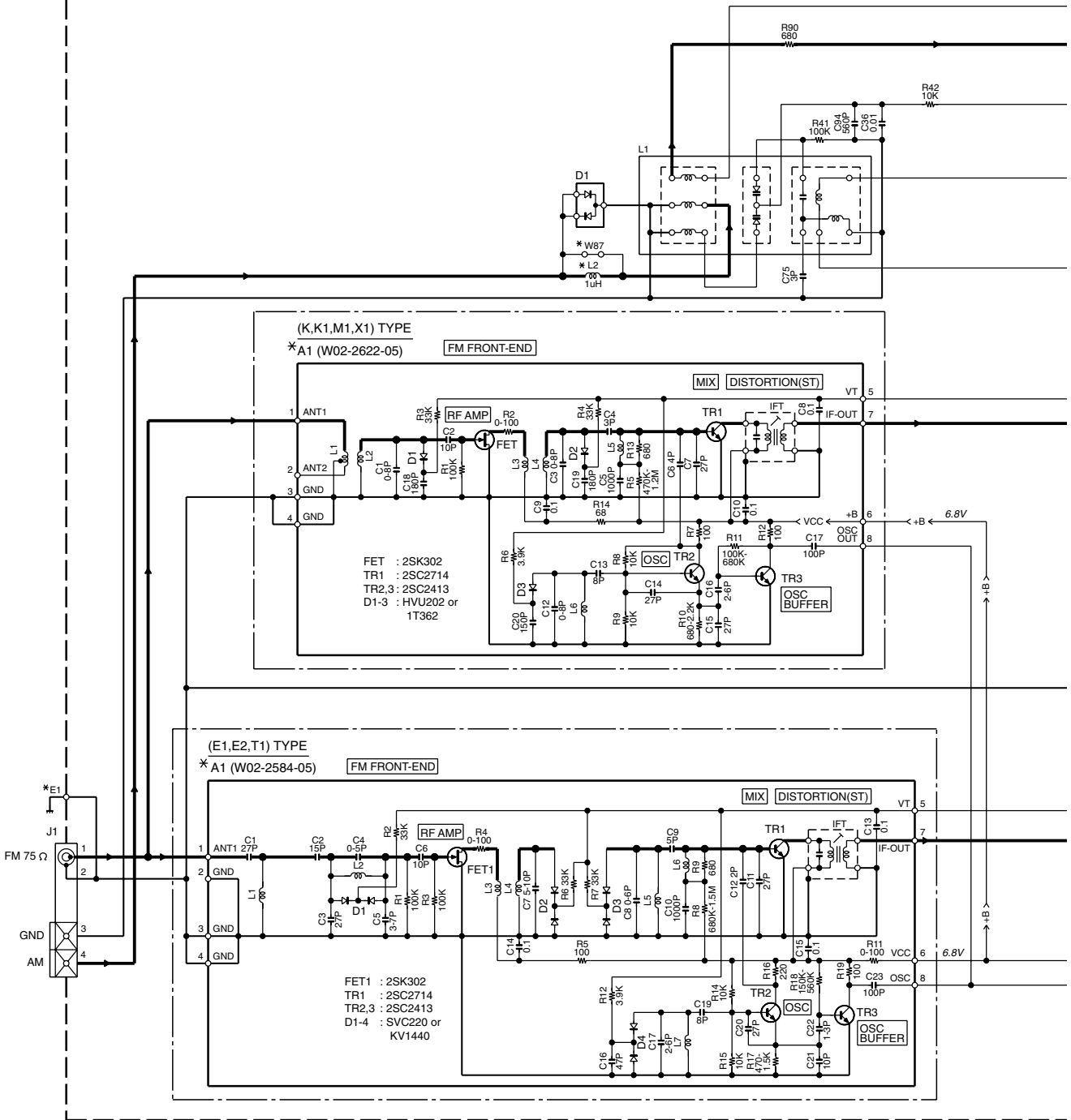

VR-5700 (X05-5130-13)

DESTINATION	UNIT No.	(A)	(B)	(C)	(E)	A1	C70, 71,77	C25	C30, 31	C74, 92,93	C79, 80	CF1,2	E1	L2, 6,7	R8, 11	R23	R25	R27, 28	R29	R72, 73	S1	W56	W82, 83,87	
COUNTRY	ABB.																							
U.S.A.	K	0-13	NO			W02-2622	NO	180P	0.033	YES	1000P	L72-0596(MS2)	F10-1108	NO	33	4.7K	18K	6.8K	NO	33K	NO	NO	NO	YES

VR-5900 (X05-5130-12)

DESTINATION	UNIT No.	(A)	(C)	(F)	(B)	A1	C70, 71,77	C25	C30, 31	C74, 92,93	C79, 80	CF1,2	E1	L2, 6,7	R8, 11	R23	R25	R27, 28	R29	R72, 73	S1	W56	W82, 83,87	
COUNTRY	ABB.																							
U.S.A.	K1	0-12	YES			W02-2622	NO	180P	0.033	YES	1000P	L72-0596(MS2)	F10-1108	NO	33	4.7K	18K	6.8K	NO	33K	NO	NO	NO	YES

KRF-X9995D (X05-5132-72)

DESTINATION	UNIT No.	(A)	(C)	(F)	(B)	A1	C74, 77,92,93	C25	C30, 31	C70, 71	C79, 80	CF1,2	E1	L2, 6,7	R8	R11	R23	R25	R27, 28	R29	R72, 73	S1	W56,82, 83,87	
COUNTRY	ABB.																							
EUROPE	E1	2-72	YES			W02-2584	NO	180P	0.022	YES	4700P	L72-0536(MS3)	F10-1109	YES	10	22	15K	27K	4.3K	NO	3.9K	NO	NO	NO

KRF-X9995D-S (X05-513X-XX)

DESTINATION	UNIT No.	(A)	(C)	(F)	(B)	A1	C25	C30, 31	C70, 71	C74, 92,93	C77	C79, 80	CF1,2	E1	L2, 6,7	R8	R11	R23	R25	R27, 28	R29	R72, 73	S1	W56	W82, 83,87
COUNTRY	ABB.																								
GENERAL MARKET	M1	0-22	NO		YES	W02-2622	330P		NO	YES	YES	1500P 1200P	L72-0531(MA5)	F10-1108	NO	33	33	4.7K 6.8K	18K	6.8K	YES	33K	YES	YES	YES
AUSTRALIA	X1	0-72					0.022																		
U.K.	T1																								
EUROPE	E2	2-72	YES		NO	W02-2584	180P		YES	NO	NO	4700P	L72-0536(MS3)	F10-1109	YES	10	22	15K	27K	4.3K	NO	3.9K	NO	NO	NO

CAUTION: For continued safety, replace safety critical components only with manufacturer's recommended parts (refer to parts list). Δ indicates safety critical components. For continued protection against risk of fire, replace only with same type and rating fuse(s). To reduce the risk of electric shock, leakage-current or resistance measurements shall be carried out (exposed parts are acceptably insulated from the supply circuit) before the appliance is returned to the customer.

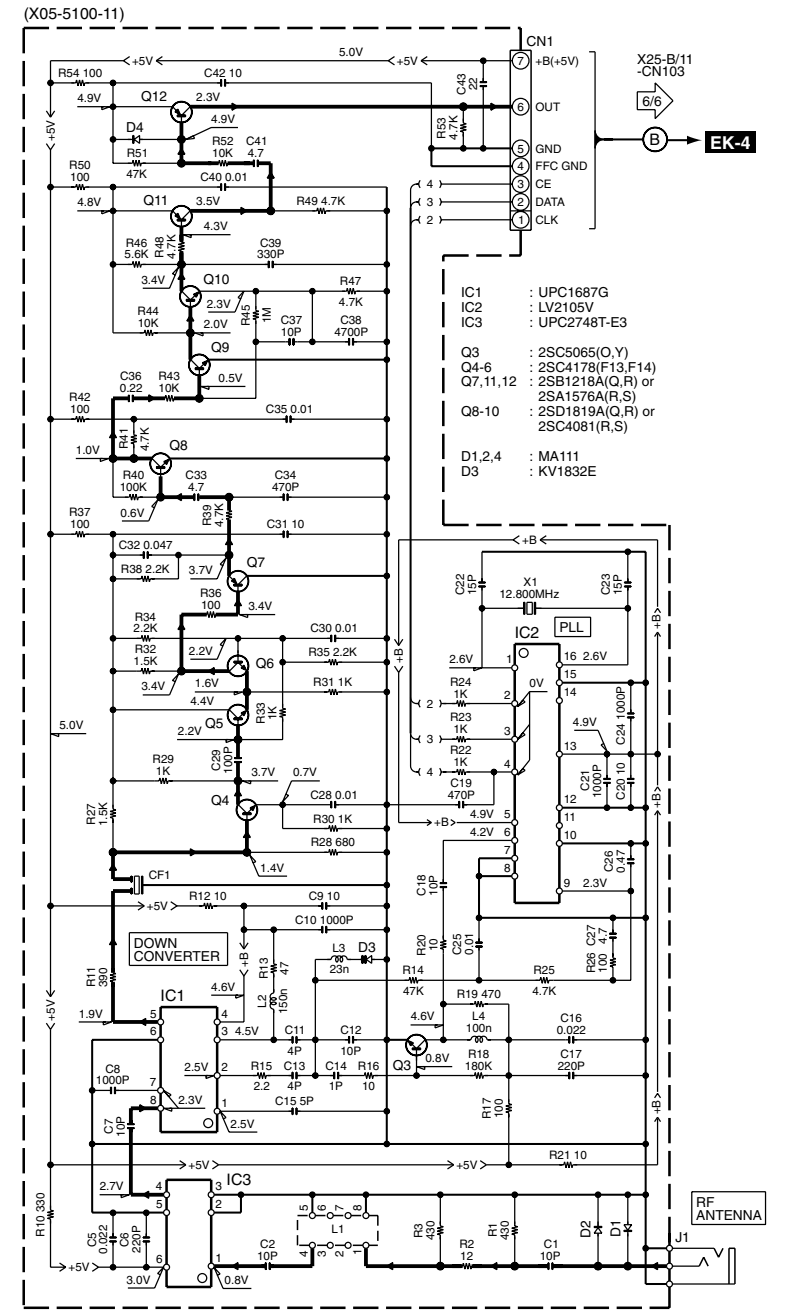
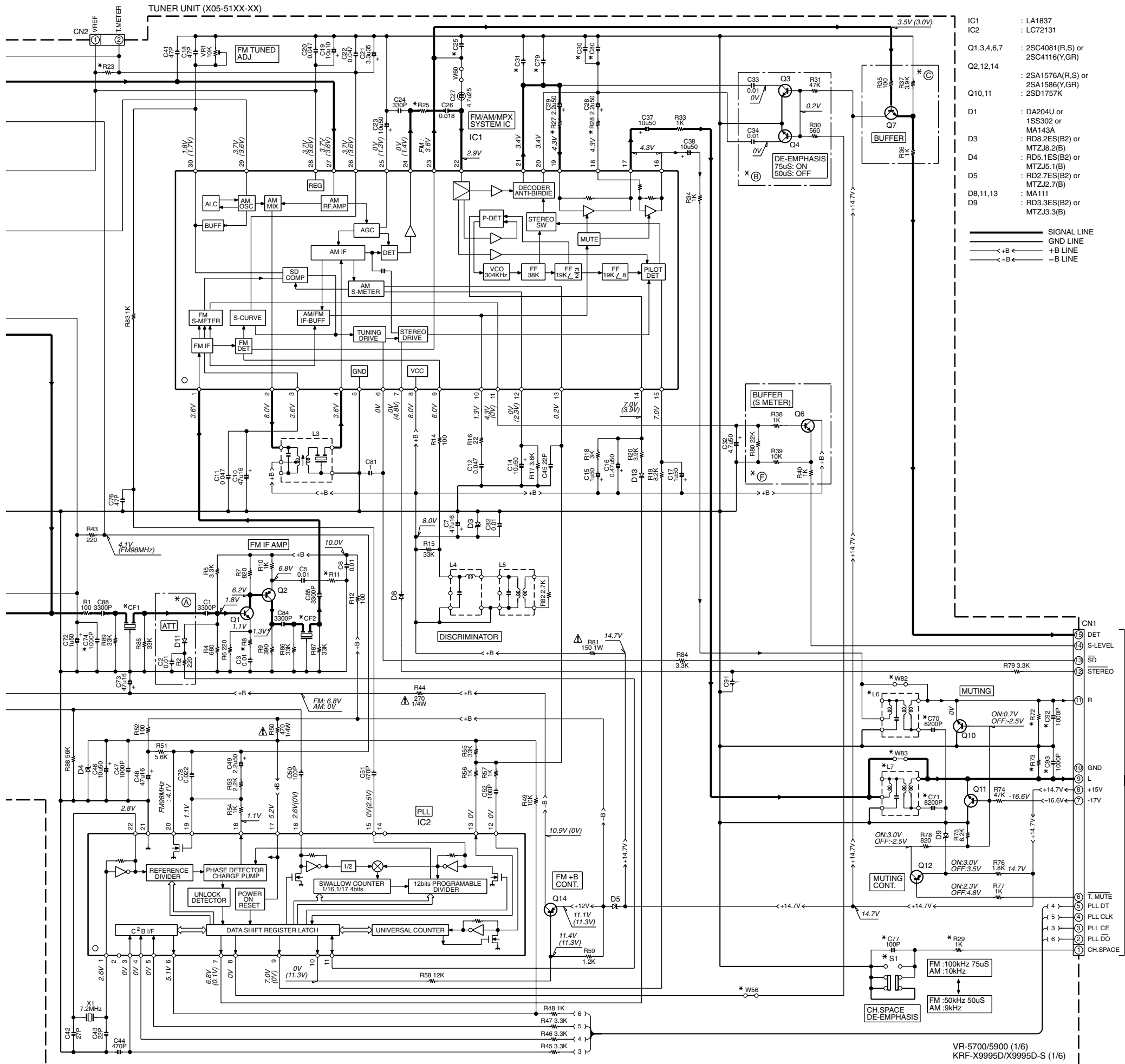

CH13-A/6 -WH1

CHANNEL FREQUENCY (MHz)			
CHANNEL	1	2	3
OSC FREQUENCY	417.3	414.3	411.3

VT VOLTAGE

CHANNEL			
CHANNEL	1	2	3
VT VOLTAGE	2.40 ± 0.5	2.35 ± 0.5	2.30 ± 0.5

The DC voltage is an actual reading measured with a high impedance type voltmeter as the AM/FM signal generator is specified to the conditions as shown in the list below. The measurement value may vary depending on the measuring instruments used or on the product. The value shown in () is actual reading measured in the AM mode.

MODE	CARRIER	MODULATION		ANT INPUT
		FREQUENCY	DEVIATION	
FM	98MHz	1kHz	STEREO 67.5kHz 7.5kHz(Pilot)	60dB
AM	1000(999)kHz	400Hz	MONO 30% MOD	60dB

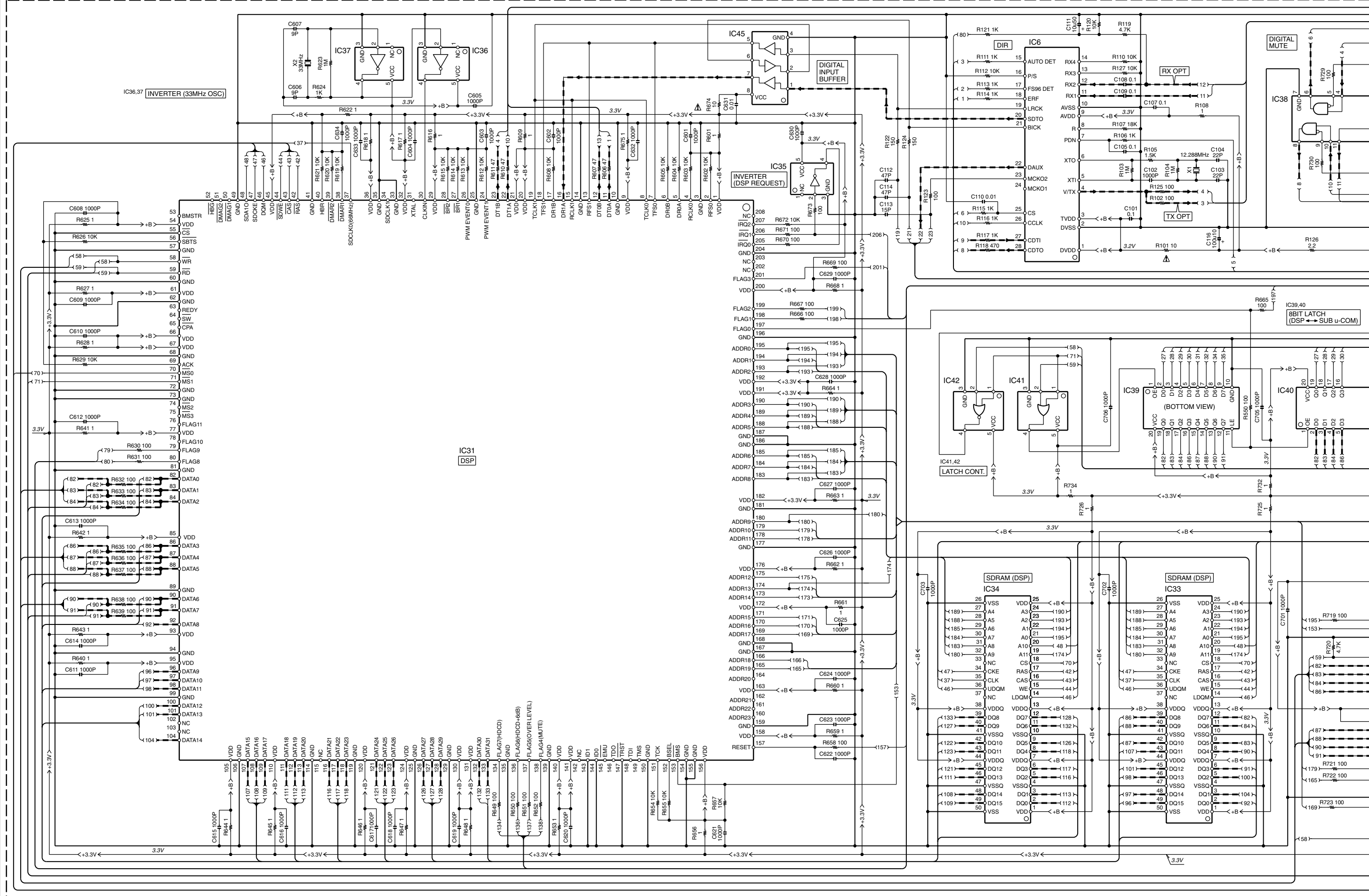

The DC voltage is an actual reading measured with a high impedance type voltmeter with a cassette loaded at playback mode. The measurement value may vary depending on the measuring instruments used or on the product. Bias circuit DC voltage is measured while in the record mode.

DOLBY and the double-D symbol are trademarks of Dolby Laboratories Licensing Corporation. Noise reduction circuit made under license from Dolby Laboratories Licensing Corporation.

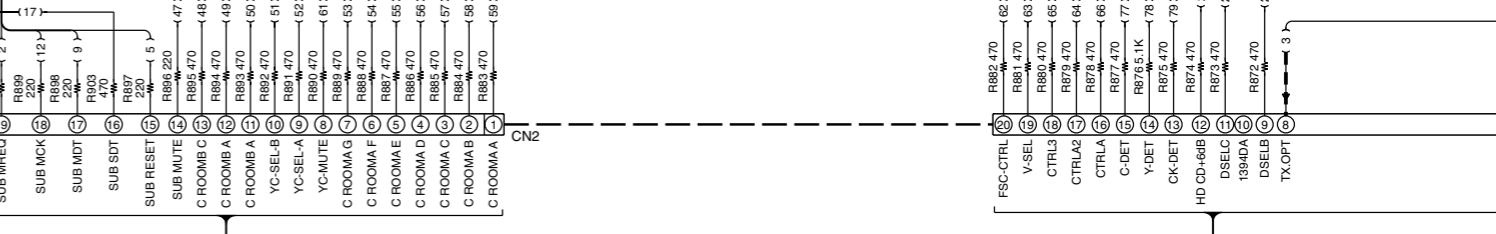
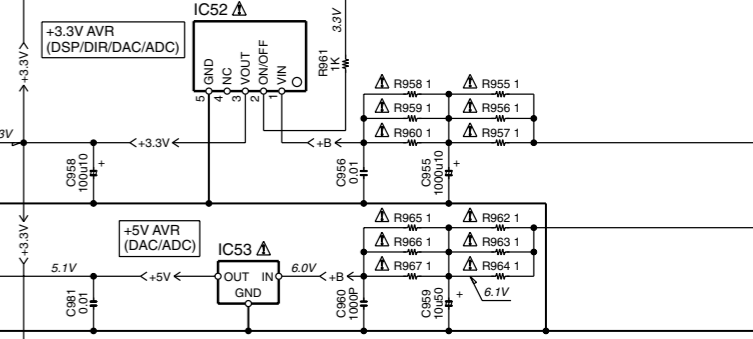
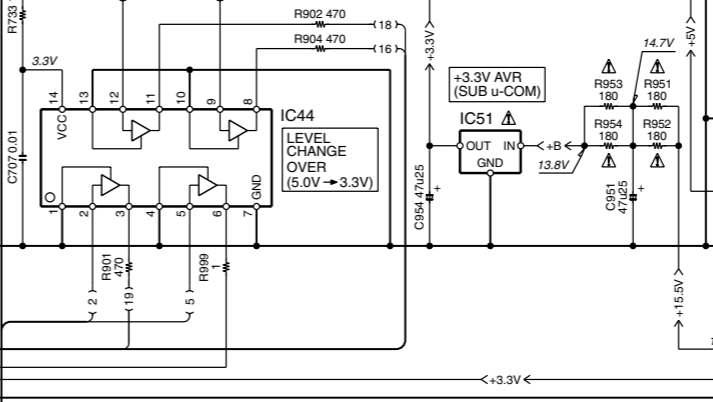
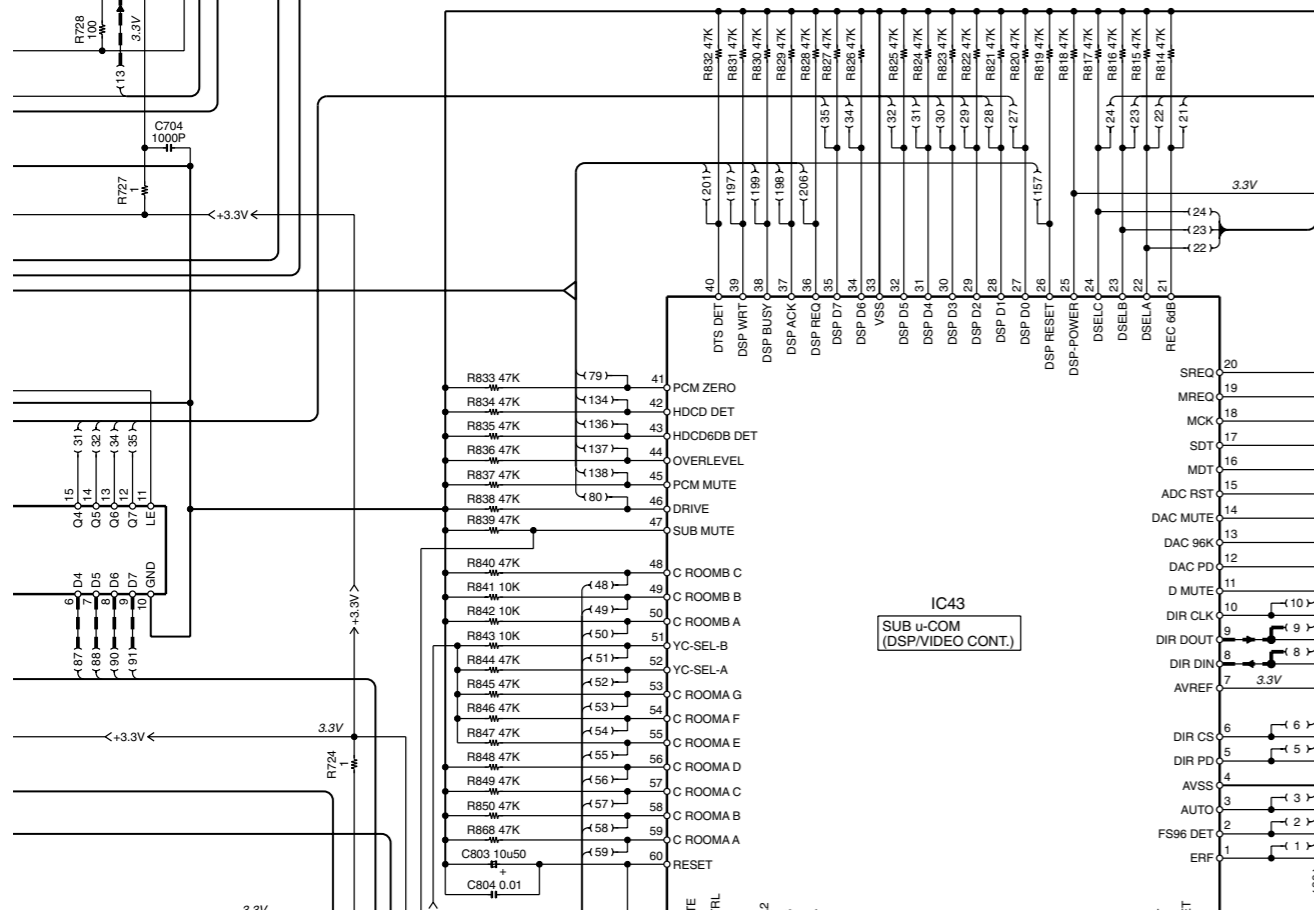
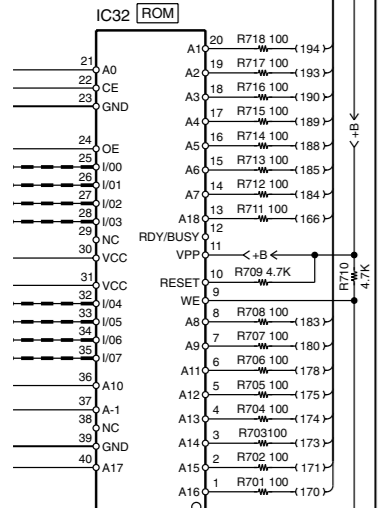
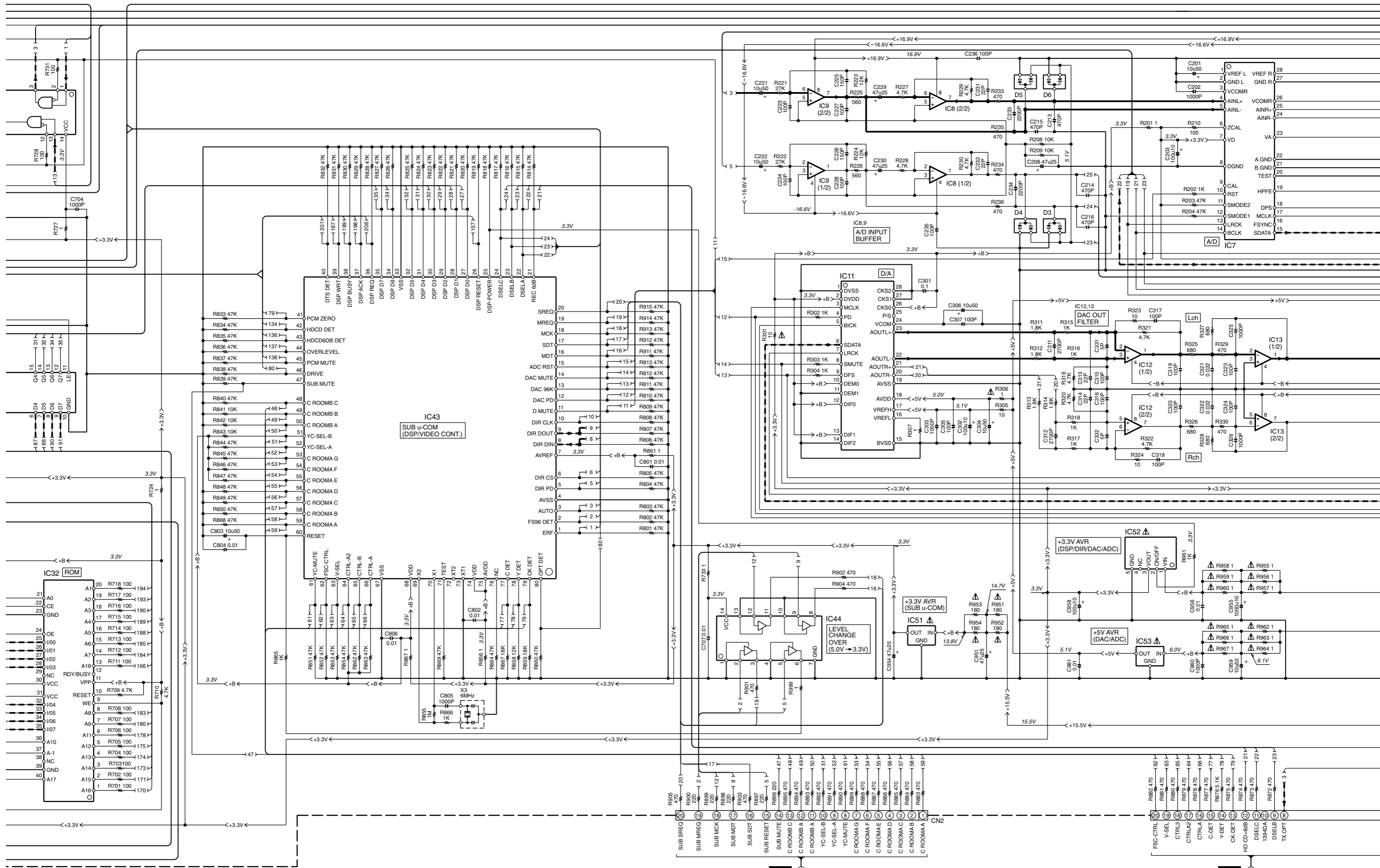

(X08-3090-11)

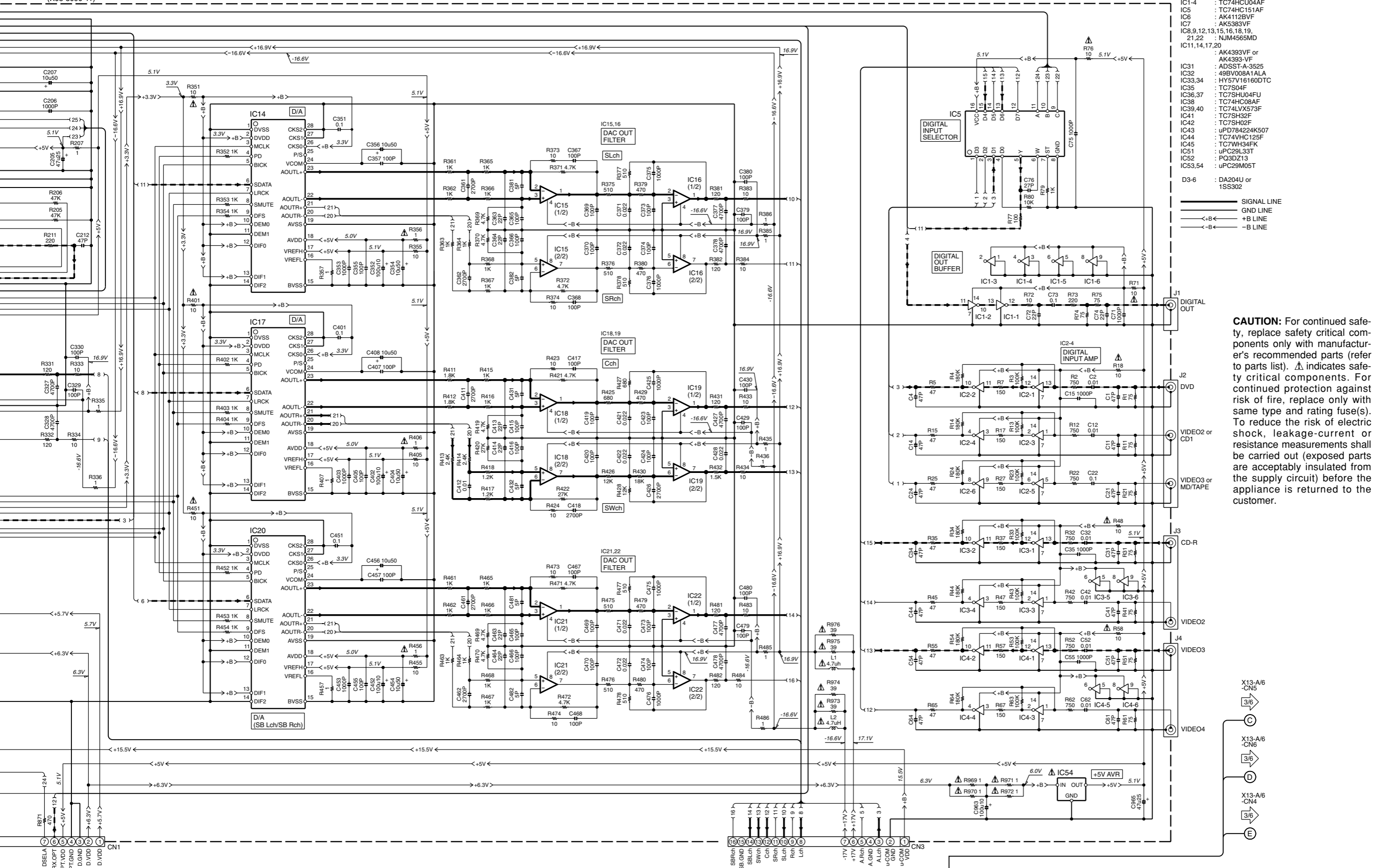

- IC1-4 : TC74HC04AF
- IC5 : TC74HC151AF
- IC6 : AK4112BVF
- IC7 : AK5383VF
- IC8,9,12,13,15,16,18,19,21,22 : NJM4565MD
- IC11,14,17,20 : AK4393VF or AK4393-VF
- IC31 : ADSST-A-3525
- IC32 : 49BV008A1ALA
- IC33,34 : HY57V16160DTC
- IC35 : TC7S04F
- IC36,37 : TC7SHU04FU
- IC38 : TC74HC08AF
- IC39,40 : TC74LVX573F
- IC41 : TC7SH02F
- IC42 : uPD784224K507
- IC44 : TC74VHC125F
- IC45 : TC7WH34FK
- IC51 : PC29L33T
- IC52 : PQ3DZ13
- IC53,54 : uPC29M05T

D3-6 : DA204U or 1SS302

— SIGNAL LINE
 — GND LINE
 — +B LINE
 — -B LINE

CAUTION: For continued safety, replace safety critical components only with manufacturer's recommended parts (refer to parts list). Δ indicates safety critical components. For continued protection against risk of fire, replace only with same type and rating fuse(s). To reduce the risk of electric shock, leakage-current or resistance measurements shall be carried out (exposed parts are acceptably insulated from the supply circuit) before the appliance is returned to the customer.

BJ-3 VR-5700/5900 (2/6)
 KRF-X9995D/X9995D-S (2/6)

Y05-4220-10

KRF-X9995D/X9995D-S/VR-5700/5900

KENWOOD

X05-513/514 -CN1
1/6
A
X08-CN3
2/6
E
2
3
4
5
6
X08-CN2
2/6
C
X08-CN1
2/6
D
7

- IC1 : TA7805TS
IC2 : S-80740AL-A4 or S-80840ALUP
IC3 : UPD784217A516
IC4 : TC74HCT7007AF
IC5 : TC74HC164AF
IC6 : UPD17215GT-737
IC7 : LC72723M
- Q1,35,37,43,46,52 : 2SC4081(R,S) or 2SC4116(Y,G,R)
Q2,16,61 : DTC124EUA or UN5212
Q3,5,7,9,11,13 : DTA1132UA or UN5119
Q4,6,8,10,12,14 : DTC143TUA or UN5216
Q15,18,82 : DTA143TUA or UN5116
Q17 : 2SC3940A(R,S)
Q19 : 2SC4213(B)
Q31,32 : 2SK246(Y,G,R)
Q33,34,41,42,45 : 2S81375
Q36,38 : 2SA1576A(R,S) or 2SA1586(Y,G,R)
Q51 : 2SD2012
- D1,3,27-29 : U1BC44
D2,4-6,11-23,36,37,43-45,63 : MA111
D7,9,35,38 : DAN202U or 1SS301
D8,10,41,42 : DAP202U or 1SS300
D30 : UDZS5.6B or UDZ5.6B
D51 : S1ZB20(4072)
D52 : UDZS8.2B or UDZ8.2B
D53 : UDZ37.5B or UDZ7.5B
D61 : D4SBL20UF03
D62 : UDZS6.2B or UDZ6.2B
D71 : KBP02ML-6127
D72 : UDZ16B
D80,81 : DA204U or 1SS302
- ES-4
ON STANDBY KEY
MOTOR GND
VCC +6V
U-COM GND
CN1
IR +14V
U-COM VDD
IR GND
AC1
AC2
OPEN SENS
CLOSE SENS
ON STANDBY KEY
SB LED
ENC.B
ENC.A
U-COM GND
INPUT DOWN KEY
TX REM(455KHz)
FL CLK
FL DI
FL DO
FL ST
FL RST
F IR
- ES-3
CN2
STANBY(LED)
ENC.B
ENC.A
U-COM GND
INPUT DOWN KEY
TX REM(455KHz)
FL CLK
FL DI
FL DO
FL ST
FL RST
F IR

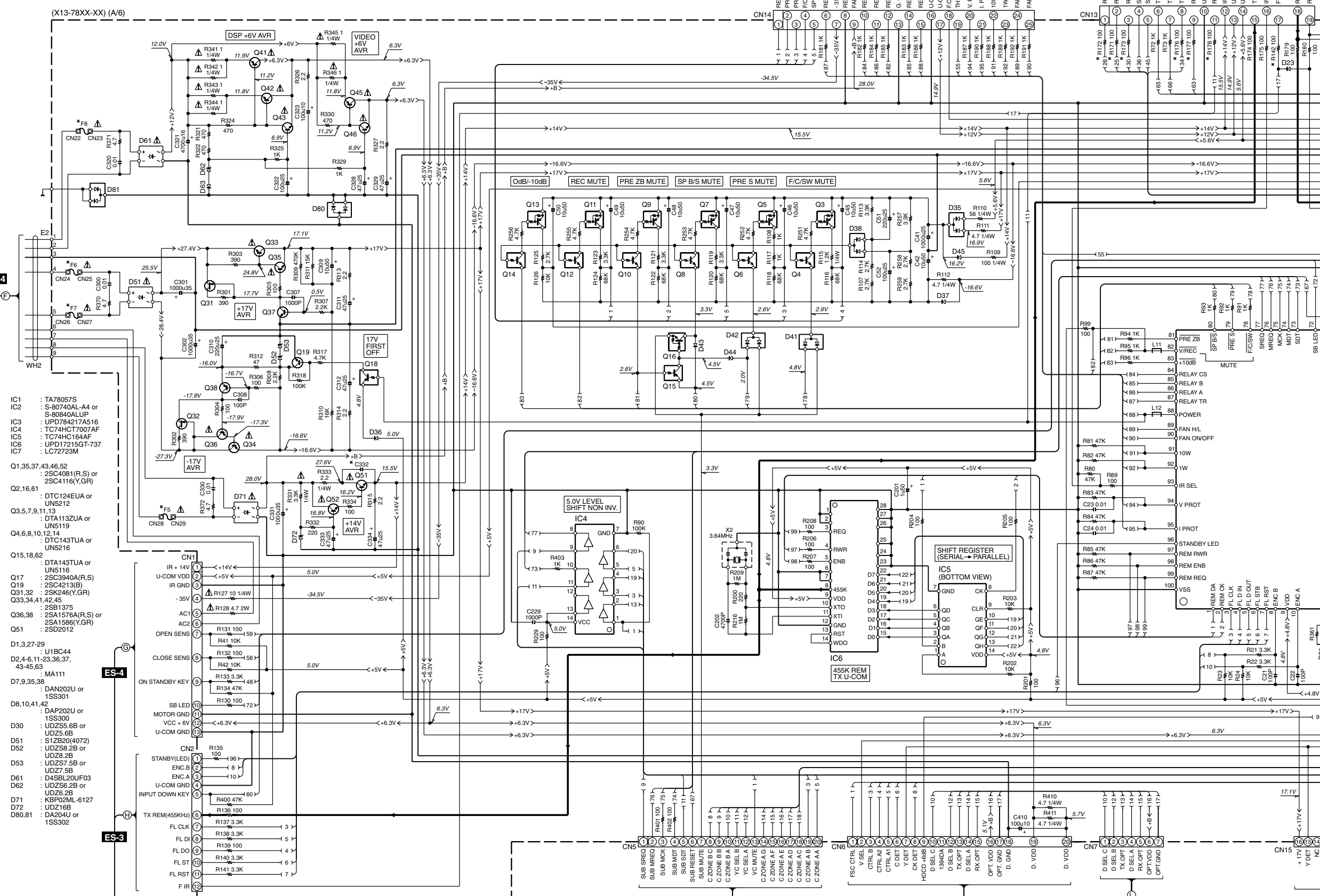
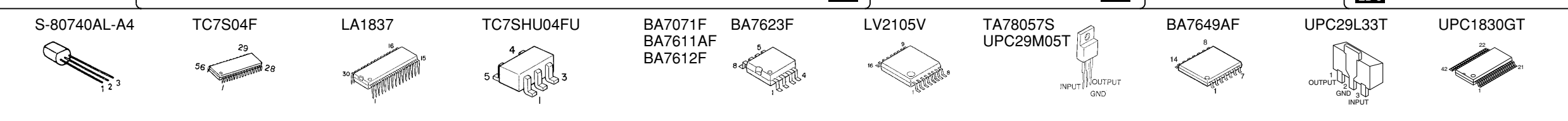

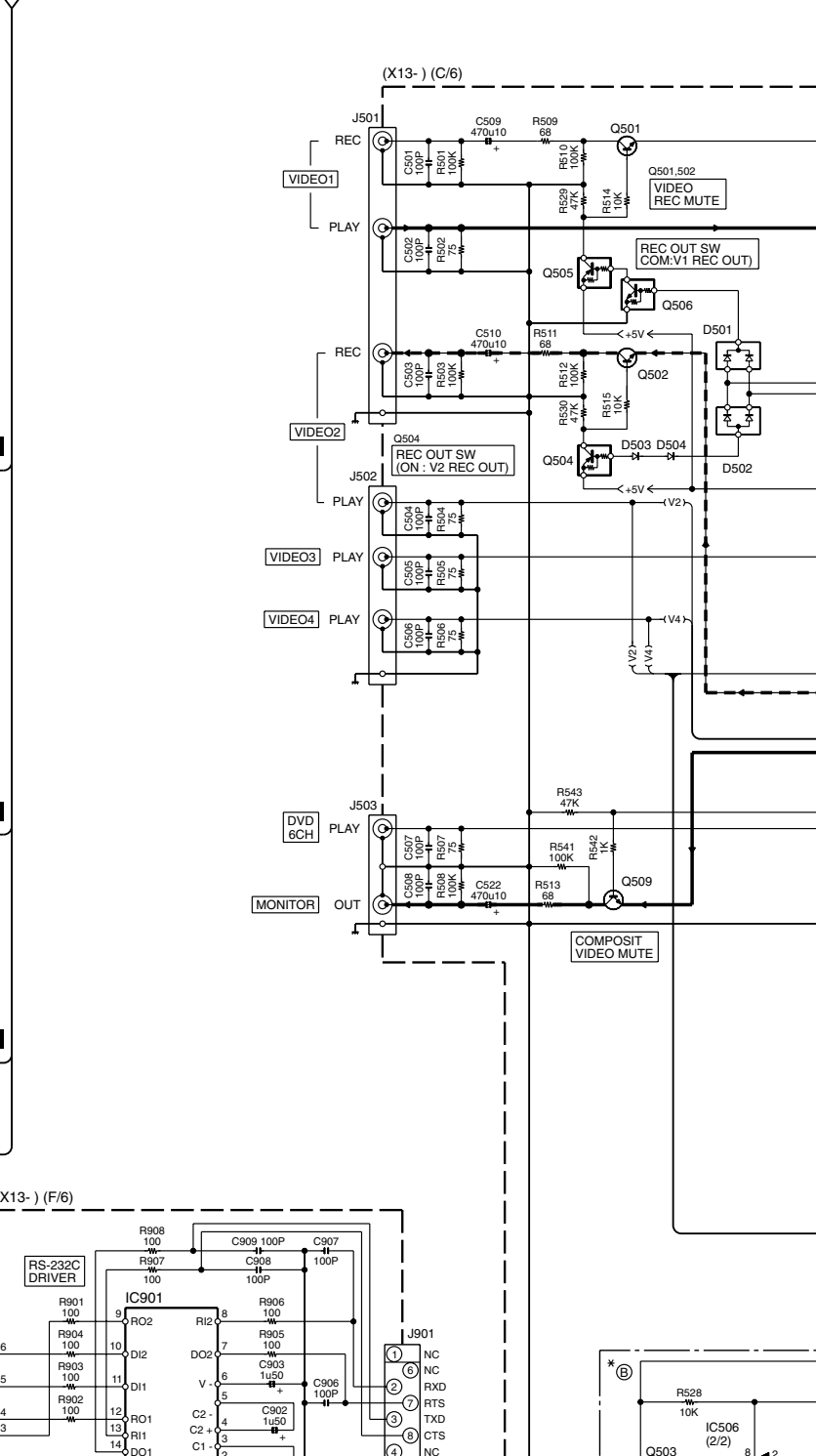
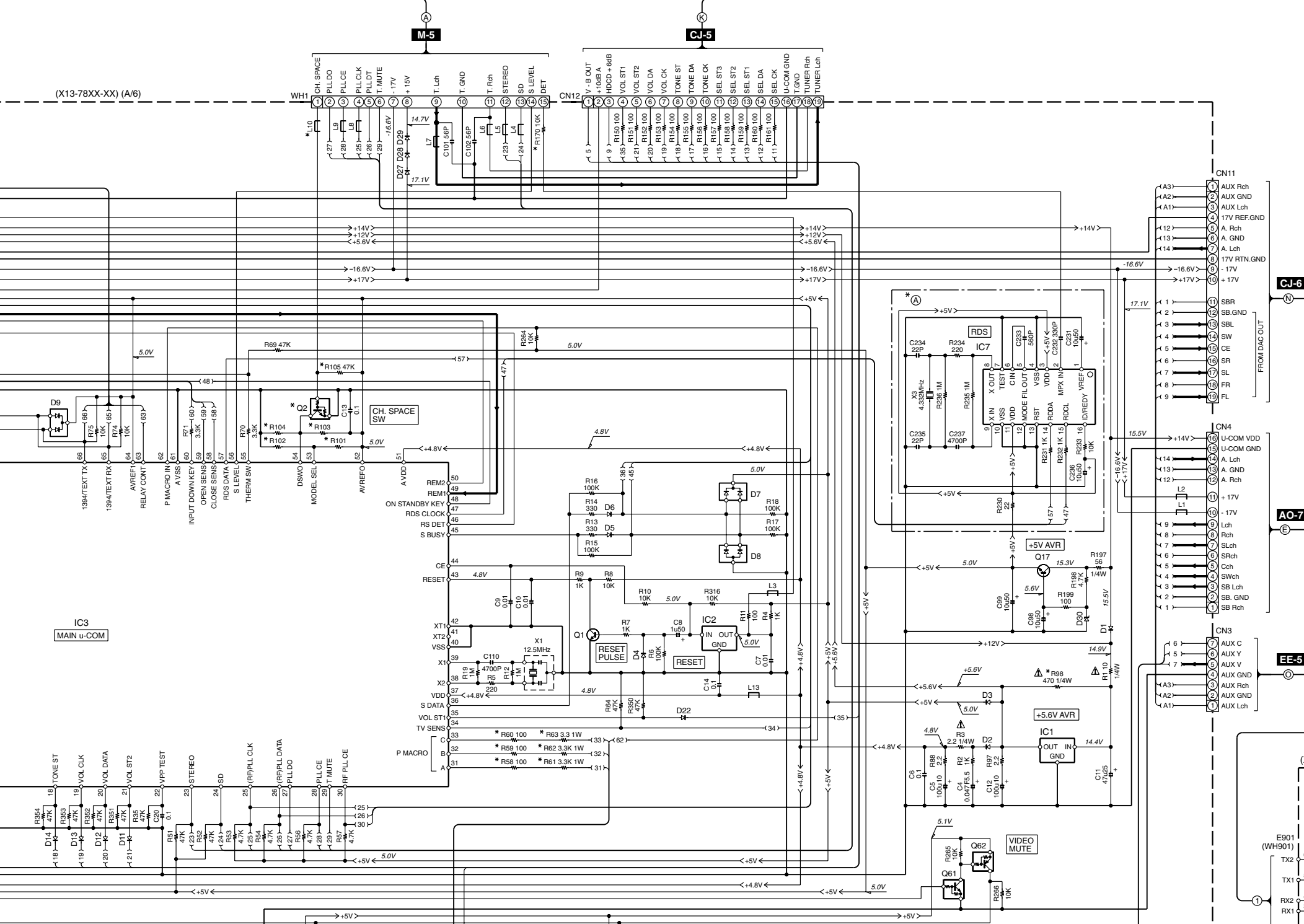

VR-5700 (X13-7840-12) (A/6)

DESTINATION	COUNTRY	ABB.	UNIT No.	F5-7	F8	L10	Q2	R58-63,105,142,170,176-178	R98,171-173,212,213	R101	R102	R103	R104
U.S.A.	K	0-12	NO	1.25A 125V	3.15A 125V	NO	NO	NO	YES	8.2K	3.3K	6.2K	4.7K

VR-5900 (X13-7840-13) (A/6)

DESTINATION	COUNTRY	ABB.	UNIT No.	F5-7	F8	L10	Q2	R58-63,98,170-173,176-178,212,213	R101	R102	R104	R105	R142
U.S.A.	K1	0-13	YES	1.25A 125V	3.15A 125V	NO	NO	YES	5.6K	4.7K	6.2K	NO	NO

KRF-X9995D (X13-784X-XX) (A/6)

DESTINATION	COUNTRY	ABB.	UNIT No.	F5-7	F8	L10	Q2	R58-63,142,170,176-178,212,213	R98,105,171-173	R101	R102	R103	R104
EUROPE	E1	2-72	YES	T1A1 250V	T3.15A1 250V	NO	NO	YES	NO	4.7K	5.6K	2.2K	8.2K

KRF-X9995D-S (X13-784X-XX) (A/6)

DESTINATION	COUNTRY	ABB.	UNIT No.	F5-7	F8	L10	Q2	R58-63,212,213	R98,171-173	R101	R102	R103	R104	R105	R142,170,176-178
GENERAL MARKET	M1	0-22	NO	NO	YES	YES	NO	NO	NO	1.8K	10K	10K	NO	YES	NO
AUSTRALIA	X1	0-72	NO	T1A1 250V	T3.15A1 250V	NO	NO	YES	NO	4.7K	5.6K	2.2K	8.2K	NO	NO
U.K.	T1	NO	NO	NO	NO	NO	NO	NO	NO	NO	NO	NO	NO	NO	NO
EUROPE	E2	2-72	YES	T1A1 250V	T3.15A1 250V	NO	NO	YES	NO	4.7K	5.6K	2.2K	8.2K	NO	YES

VR-5700 (X13-7840-12)

DESTINATION	COUNTRY	ABB.	UNIT No.	L601	L602	603
U.S.A.	K	0-12	NO	YES	NO	NO

VR-5900 (X13-7840-13)

DESTINATION	COUNTRY	ABB.	UNIT No.	L601	L602	603
U.S.A.	K1	0-13	YES	YES	YES	NO

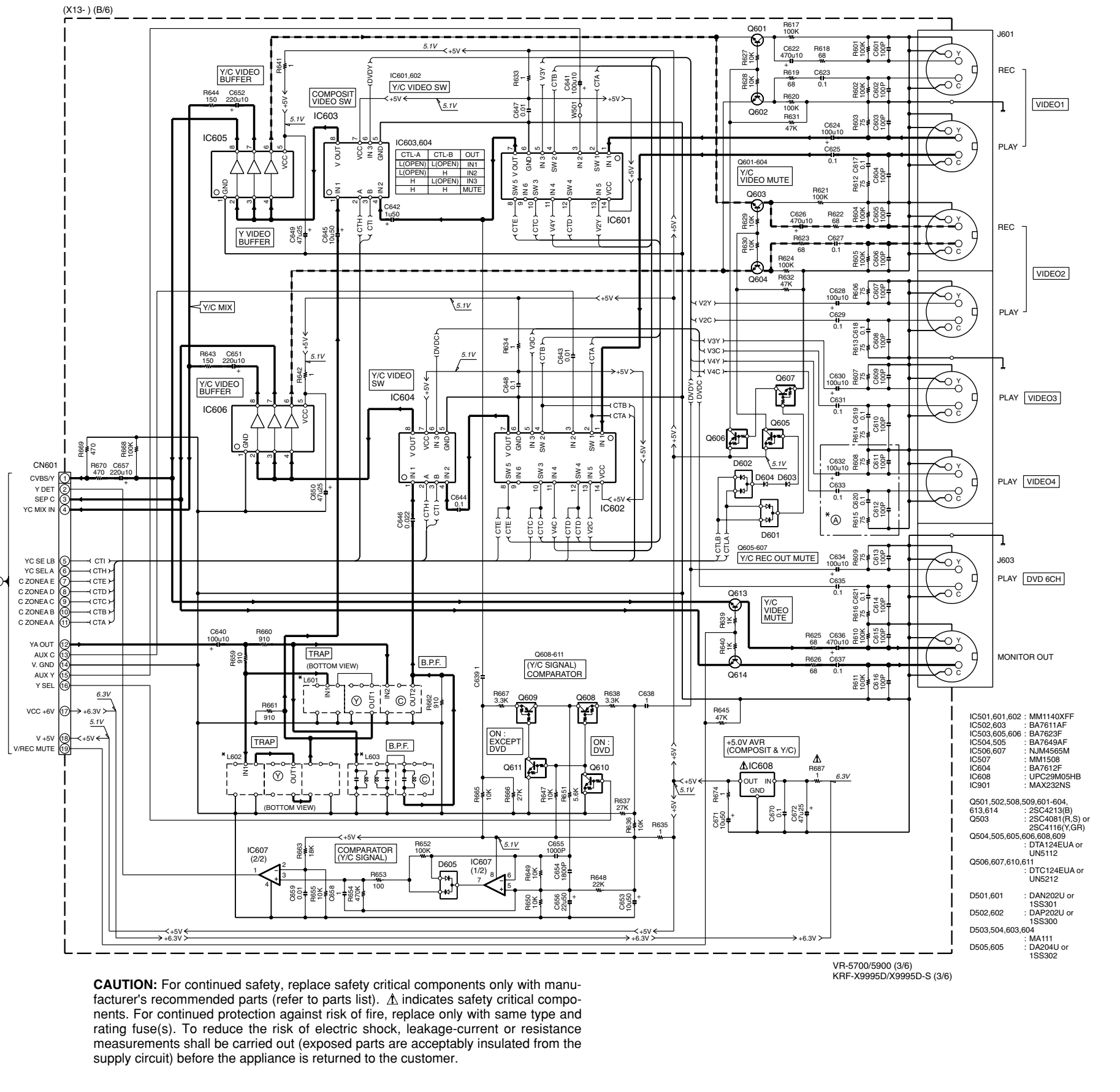
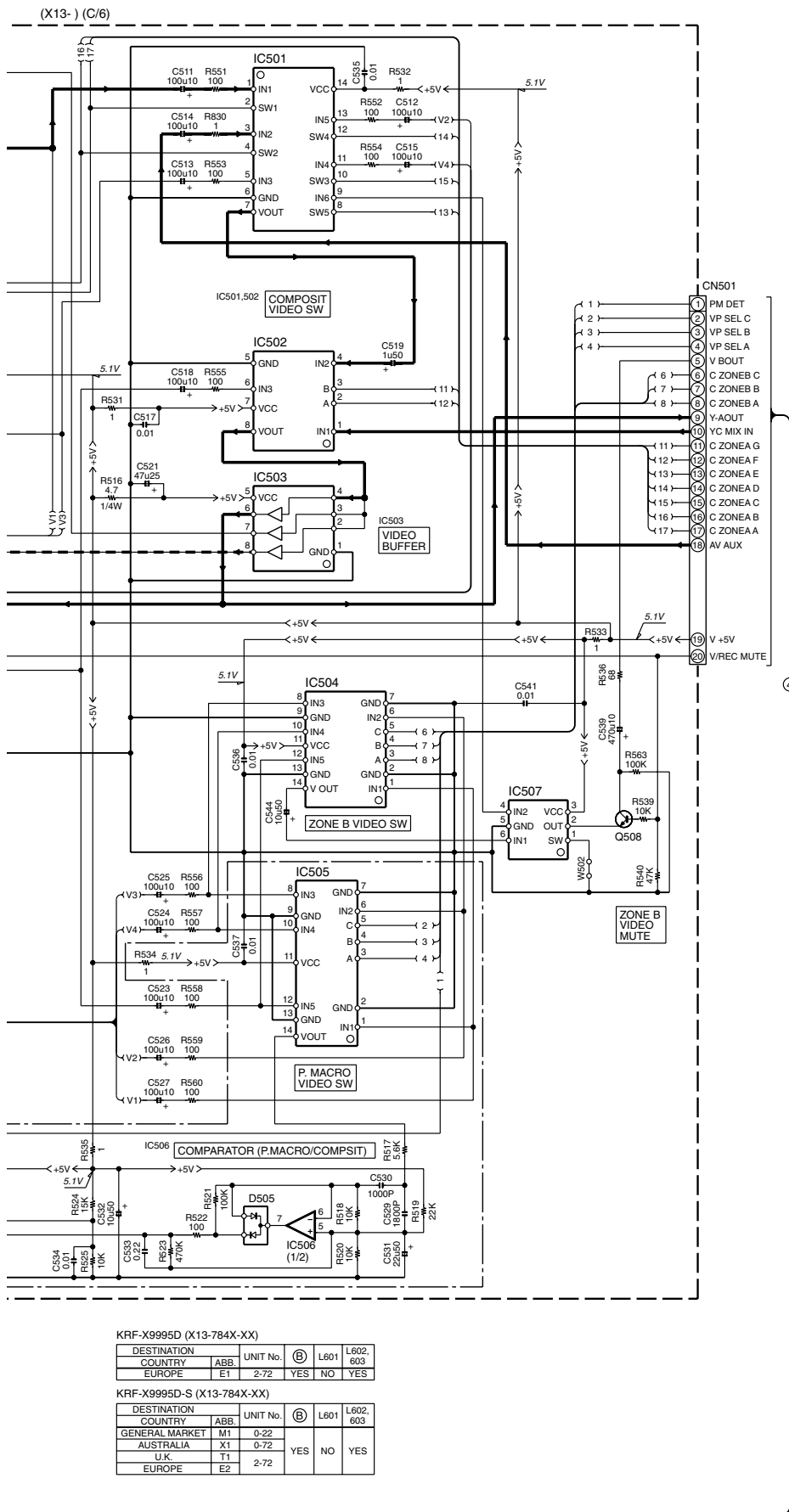

The DC voltage is an actual reading measured with a high impedance type voltmeter with a cassette loaded at playback mode. The measurement value may vary depending on the measuring instruments used or on the product. Bias circuit DC voltage is measured while in the record mode.

DOLBY and the double-D symbol are trademarks of Dolby Laboratories Licensing Corporation. Noise reduction circuit made under license from Dolby Laboratories Licensing Corporation.

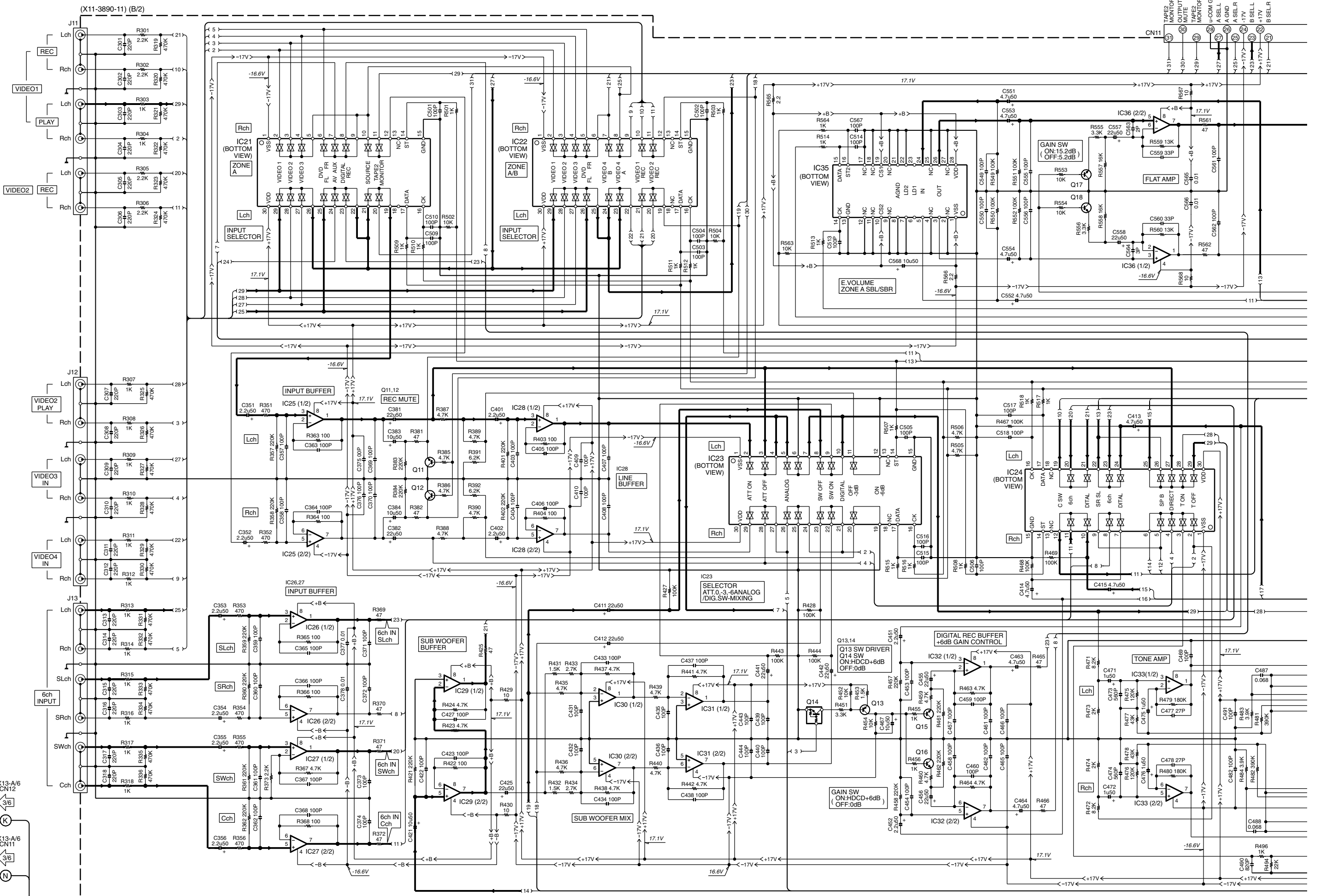

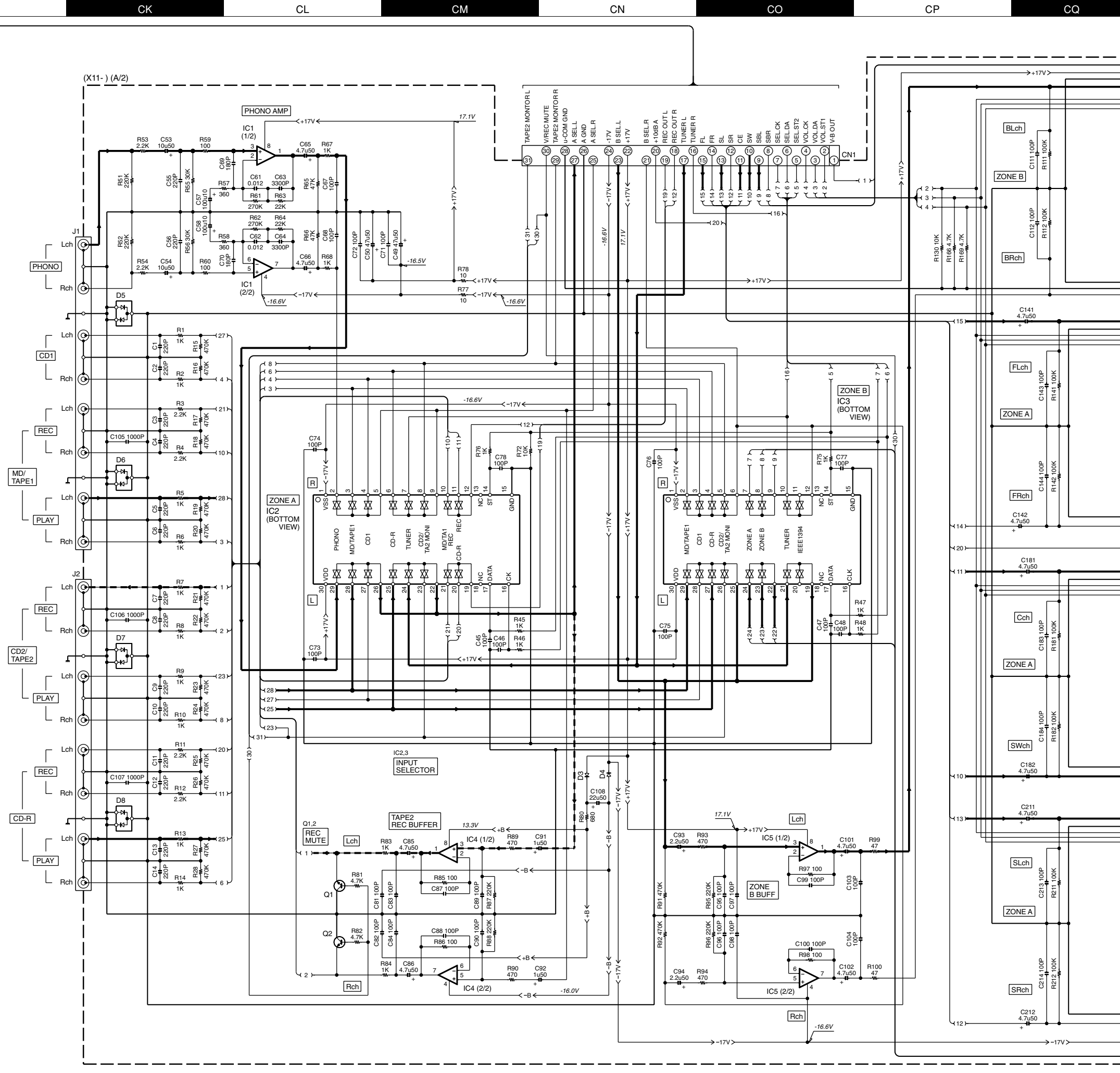
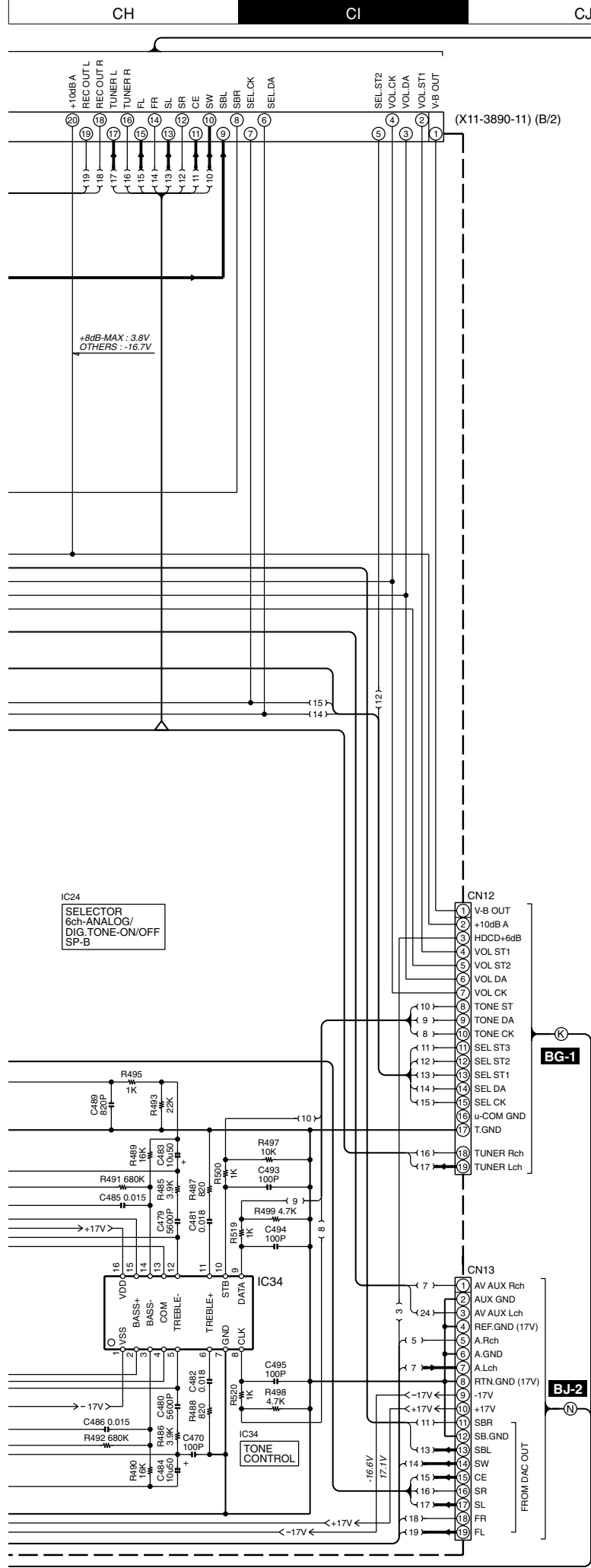

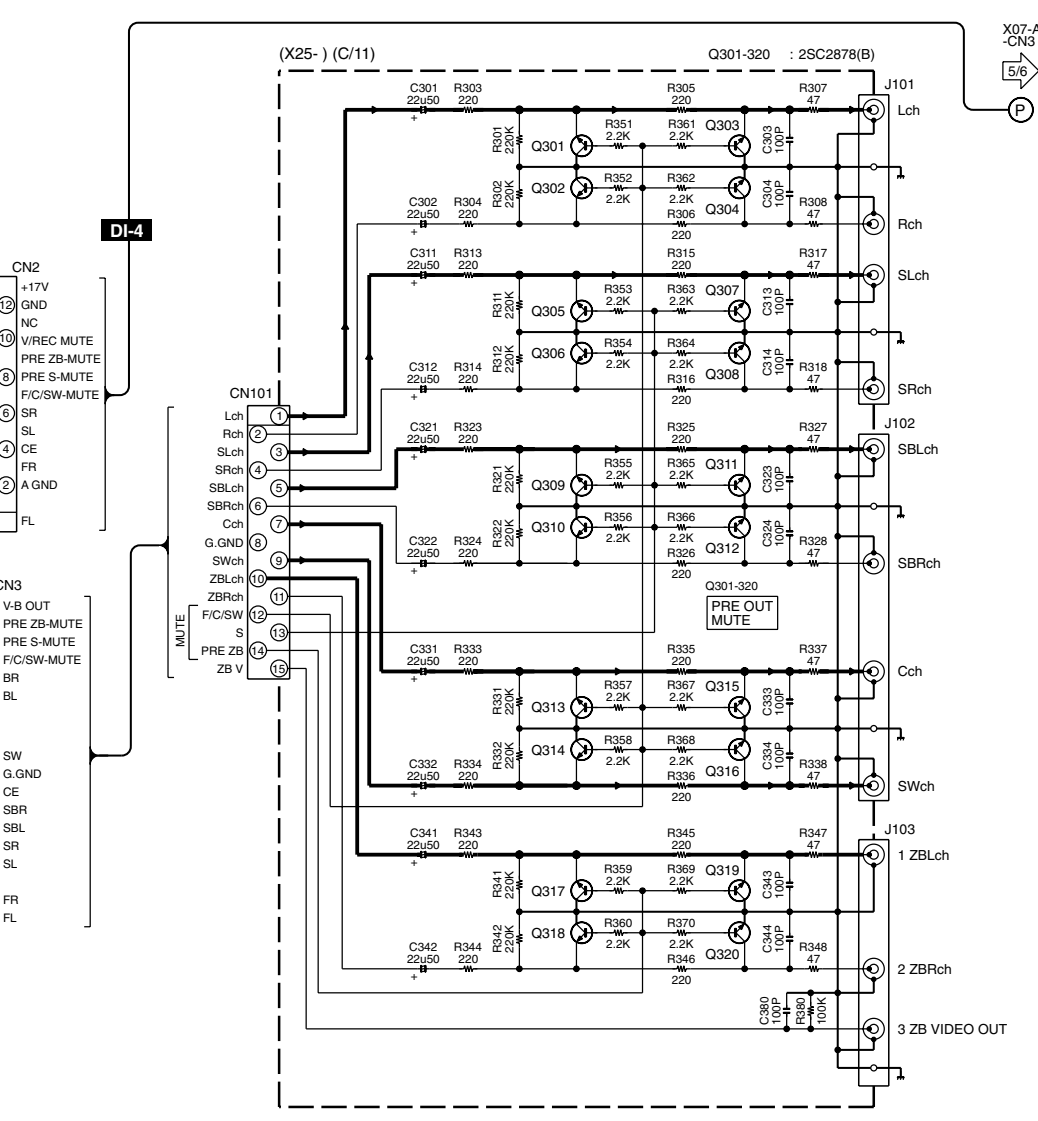
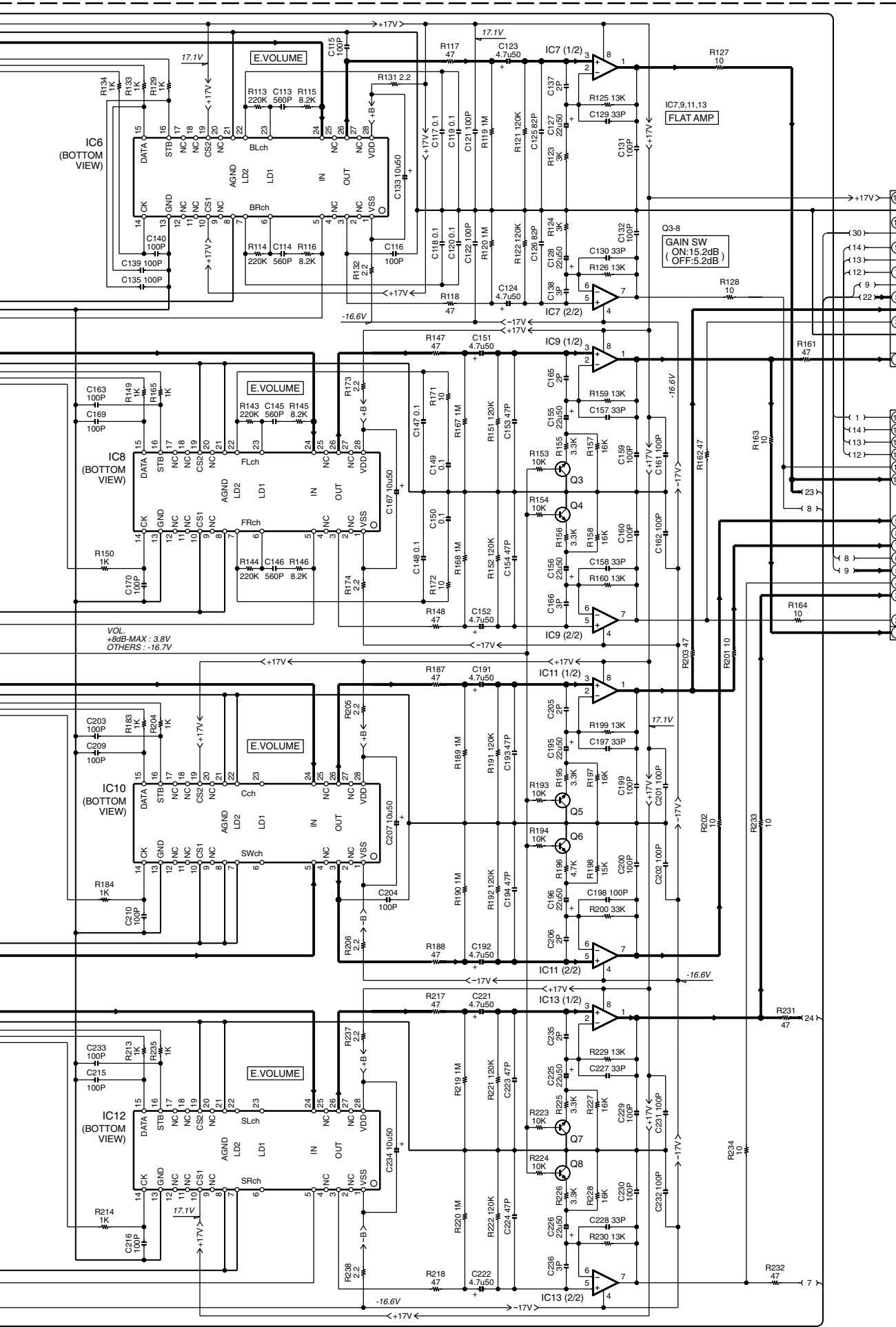

CAUTION: For continued safety, replace safety critical components only with manufacturer's recommended parts (refer to parts list). Δ indicates safety critical components. For continued protection against risk of fire, replace only with same type and rating fuse(s). To reduce the risk of electric shock, leakage-current or resistance measurements shall be carried out (exposed parts are acceptably insulated from the supply circuit) before the appliance is returned to the customer.

The DC voltage is an actual reading measured with a high impedance type voltmeter with a cassette loaded at playback mode. The measurement value may vary depending on the measuring instruments used or on the product. Bias circuit DC voltage is measured while in the record mode.

- 2SA1123
- 2SA992
- 2SC1845
- 2SC2003
- 2SC2631
- 2SC2878
- 2SC3940A
- 2SA1110
- DTA143TSA
- DTC124ESA
- UN4116
- 2SA1048
- 2SC1740S
- 2SC2458
- 2SK246
- 1SS301
- DTC143TUA
- UN5116
- UN5119
- UN5216
- 2SA1576A
- 2SA1586
- 2SB1218A
- 2SC4116
- 2SD1819A

- 2SA1535A
- 2SC3944A
- UN4212
- UN4219
- 2SB1375
- 2SD2012
- 2SC4081
- 2SD1757K
- DTA124EUA
- DTA143TUA
- DTC124EUA
- AN5560
- TC9184AP
- TA8409S
- NJM4565M
- NJM4565MD
- NJM4580ED
- TC4W53FU
- DAN202U
- DAP202U
- DA204U
- UN5212
- TC74HCT7007AF
- TC74HCU04AF
- TC74HC08AF
- TC74VHC125F
- LC72131
- NJU7311AM
- NJU7312AM
- NJU7313AM
- AK4393-VF
- UPC29M05HB
- UPC1687G

- IC1 : NJM4580ED
- IC2,21 : NJU7312AM
- IC3,22,24 : NJU7313AM
- IC4,5,7,27,33,36 : NJM4565M
- IC6,8,10,12 : TC9459N
- IC9,11,13,25,28 : NJM4565MD
- IC23 : NJU7311AM
- IC34 : TC9184AP
- IC35 : TC9459N
- Q1-8,11,12,15-18 : 2SC2878 (B)
- Q13 : 2SA1576A (R,S) or 2SA1586 (Y,GR) or DTC124EUA or UN5212
- D3,4 : MA111
- D5-8 : DA204U or 1SS302

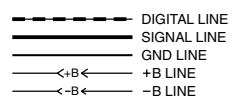

VR-5700/5900 (4/6)
KRF-X9995D/X9995D-S (4/6)

Y05-4220-10

KRF-X9995D/X9995D-S/VR-5700/5900

KENWOOD

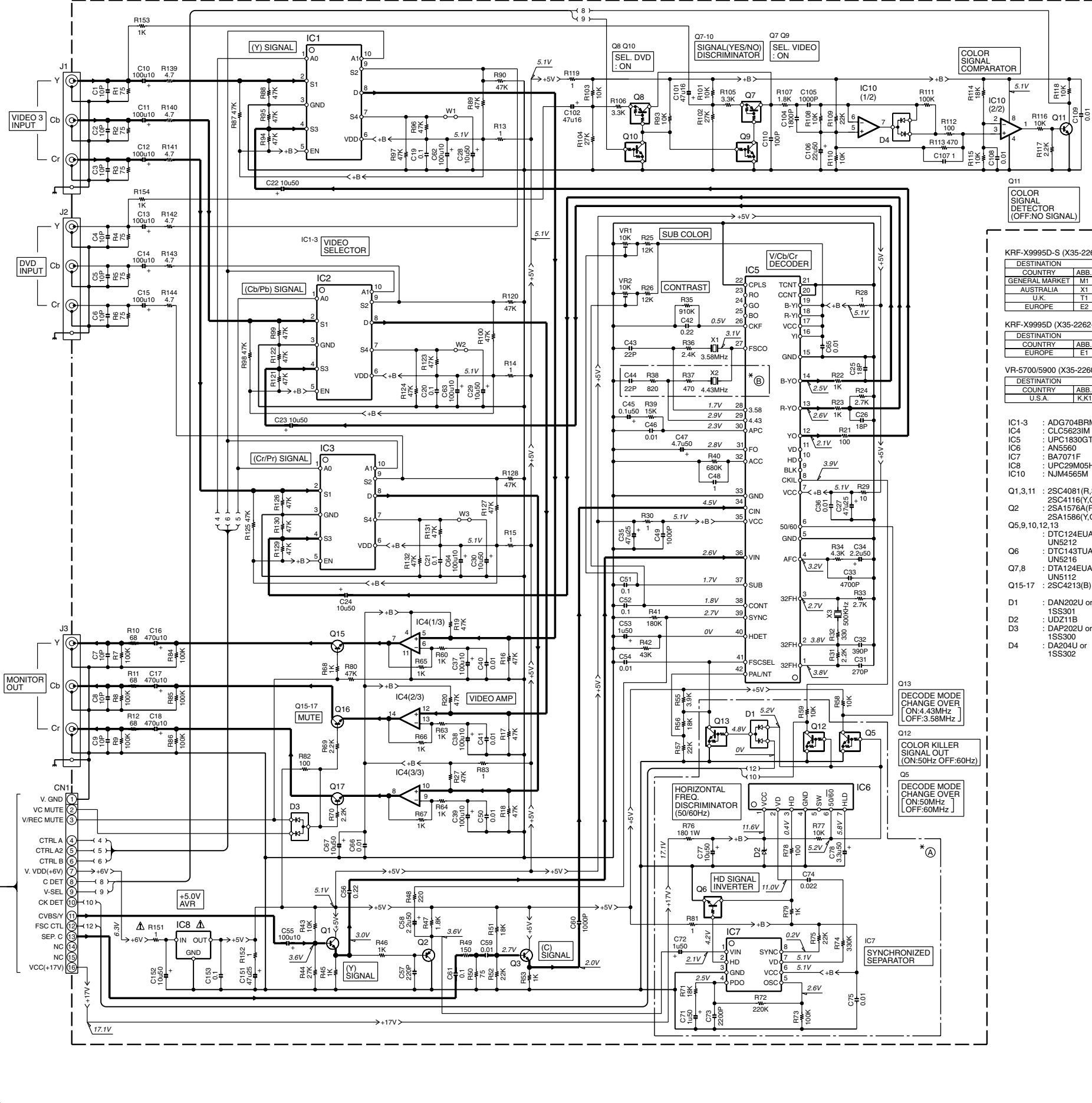

KRF-X9995D-S (X35-2262-71)

DESTINATION	COUNTRY	ABB.	UNIT No.	(A)	(B)
AUSTRALIA	T1	X1	2-71	YES	
				NO	YES
U.K.	X1	T1	2-71	YES	
				NO	YES
EUROPE	E2	X1	2-71	YES	
				NO	YES

KRF-X9995D (X35-2262-71)

DESTINATION	COUNTRY	ABB.	UNIT No.	(A)	(B)
EUROPE	E1	T1	2-71	YES	
				NO	YES

VR-5700/5900 (X35-2260-10)

DESTINATION	COUNTRY	ABB.	UNIT No.	(A)	(B)
U.S.A.	K,K1	0-10		NO	
				NO	NO

- IC1-3 : ADG7048RM
- IC4 : CLC5623M
- IC5 : UPC1830GT
- IC6 : AN5560
- IC7 : BA7071F
- IC8 : UPC29M05HB
- IC10 : NJM4565M
- Q1,3,11 : 2SC4081(R,S) or 2SC4116(Y,GR) or 2SA1576A(R,S) or 2SA1586(Y,GR)
- Q2 : DTC143TUA or UN5212
- Q6 : DTC143TUA or UN5216
- Q7,8 : DTA124EUA or UN5112
- Q15-17 : 2SC4213(B)
- D1 : DAN202U or ISS301
- D2 : UDZ11B
- D3 : DAP202U or ISS300
- D4 : DA204U or ISS302

CV-2

2

3

4

5

6

7

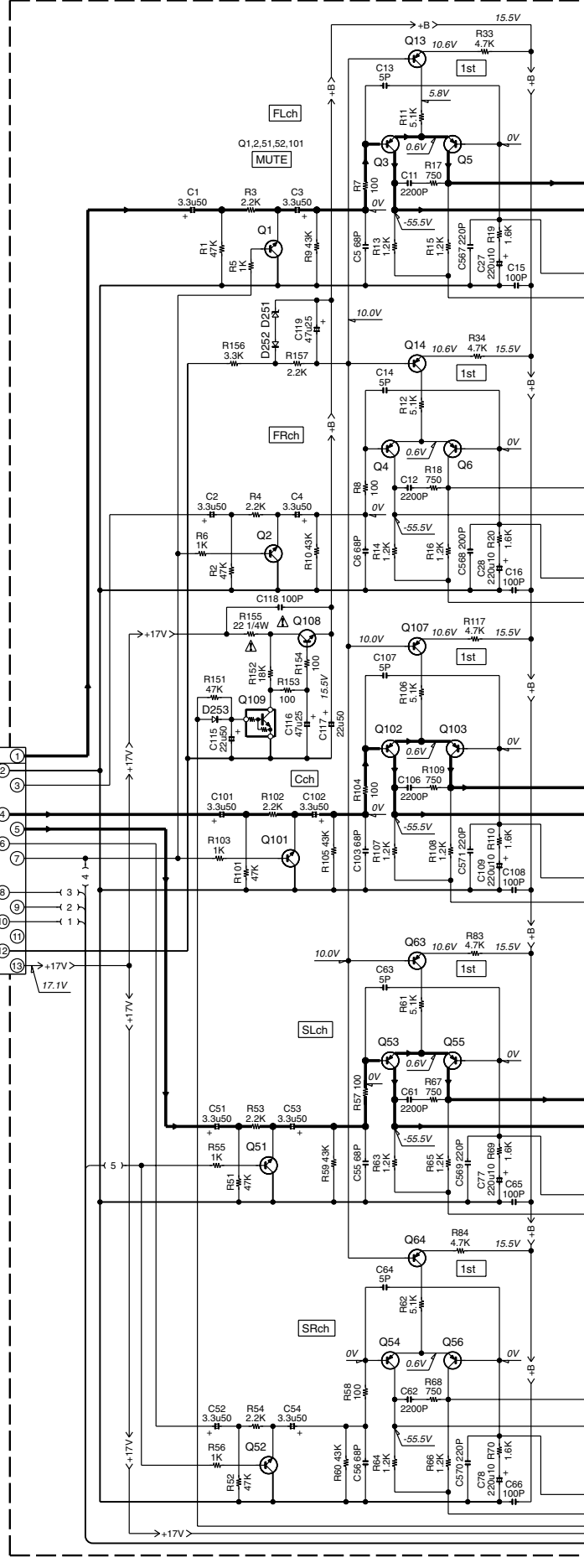
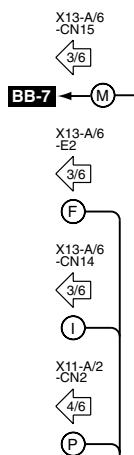

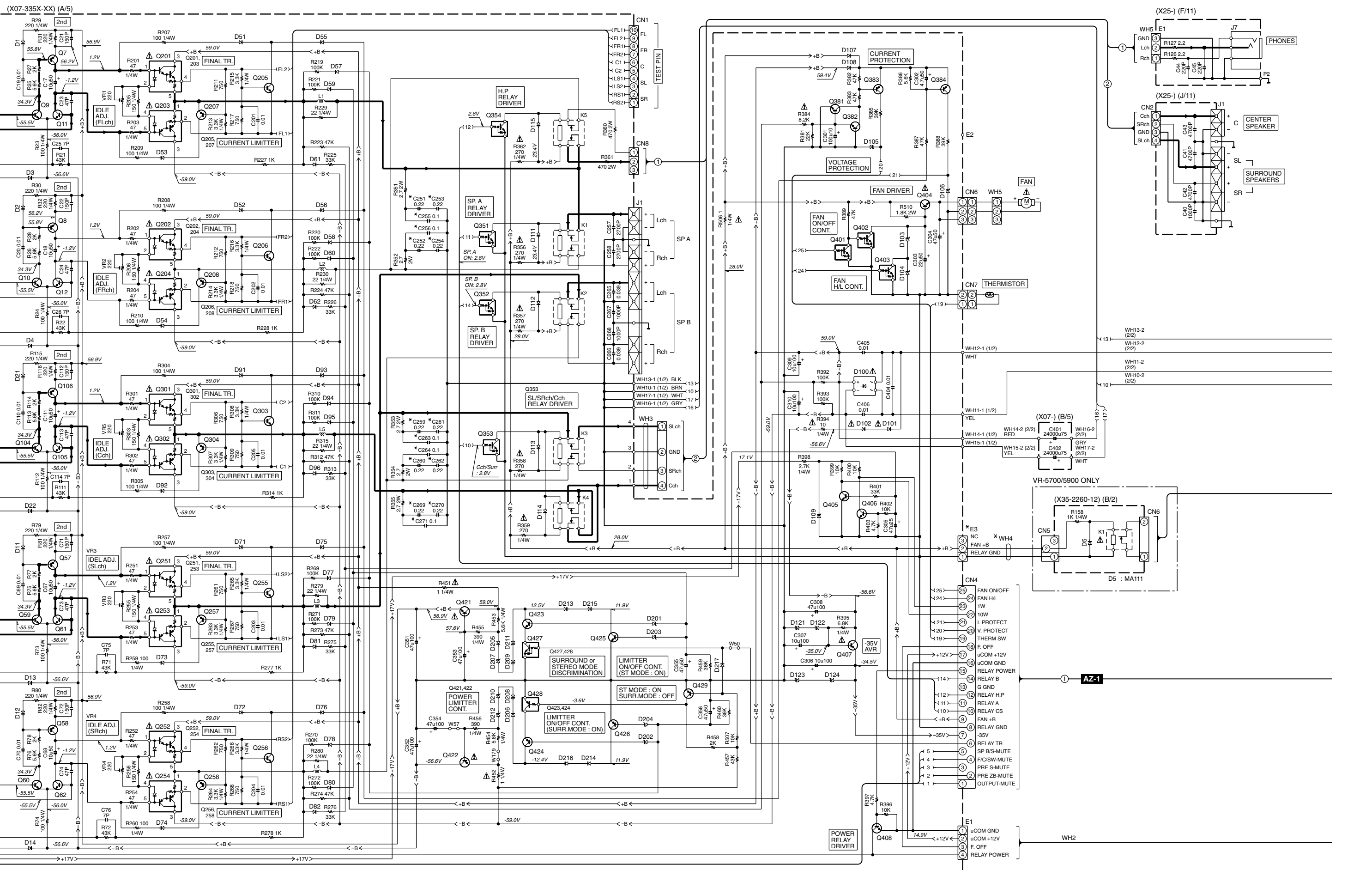

CAUTION: For continued safety, replace safety critical components only with manufacturer's recommended parts (refer to parts list). Δ indicates safety critical components. For continued protection against risk of fire, replace only with same type and rating fuse(s). To reduce the risk of electric shock, leakage-current or resistance measurements shall be carried out (exposed parts are acceptably insulated from the supply circuit) before the appliance is returned to the customer.

The DC voltage is an actual reading measured with a high impedance type voltmeter with a cassette loaded at playback mode. The measurement value may vary depending on the measuring instruments used or on the product. Bias circuit DC voltage is measured while in the record mode.

VR-5700/5900 (X07-3350-11)

DESTINATION		UNIT No.	J2	WH1 21-27	WH4 28	F1	F2,3	S1	C251-254,259- 262,269,270,454	C255,256,263, 264,271,404
COUNTRY	ABB.									
U.S.A.	K,K1	0-11	E03-0148-05	NO	YES	250V 12A	NO	NO	NO	YES

DESTINATION		CN11	CN12, 33-36	CN31, 32	E3	W501-503	W508	R502	K6	T1
COUNTRY	ABB.									
U.S.A.	K,K1	YES	NO	J13-0041-05	YES	YES	NO	YES	S76-0122-05	L07-2939-05

KRF-X9995D (X07-3352-72)

DESTINATION		UNIT No.	J2	WH1 21-28	WH4 29	F1	F2	F3	S1	C251-254,259- 262,269,270	C255,256,263, 264,271,404,454
COUNTRY	ABB.										
EUROPE	E1	2-72	E03-0149-05	YES	NO	250V T5AL	NO	250V T2,5AL	NO	YES	NO

DESTINATION		CN11, 35,36	CN12,33, 34	CN31, 32	E3	W501, 503	W502, 508	R502	K6	T1
COUNTRY	ABB.									
EUROPE	E1	YES	NO	J13-0075-05	NO	NO	YES	NO	S76-0106-05	L07-2936-05

KRF-X9995D-S (X07-335X-XX)

DESTINATION		UNIT No.	J2	WH1 28	WH21- 27	F1	F2	F3	S1	C251-254,259- 262,269,270	C255,256,263, 264,271,404	C454
COUNTRY	ABB.											
GENERAL MARKET	M1	0-22	E03-0149-05	NO	YES	250V T5AL	NO	NO	YES	YES	NO	YES
AUSTRALIA	X1	0-72	E03-0325-05	YES	NO	250V T5AL	NO	NO	NO	YES	NO	NO
U.K.	T1	0-51	E03-0310-05	NO	NO	250V T5AL	NO	NO	NO	NO	NO	NO
EUROPE	E2	2-72	E03-0149-05	NO	NO	250V T2,5AL	NO	NO	NO	NO	NO	NO

DESTINATION		CN11	CN12, 33,34	CN31, 32	CN35, 36	E3	W501	W502	W503	W508	R502	K6	T1
COUNTRY	ABB.												
GENERAL MARKET	M1	NO	YES	J13-0075-05	NO	NO	NO	NO	NO	YES	NO	S76-0106-05	L07-2937-05
AUSTRALIA	X1	NO	NO	J13-0075-05	NO	NO	NO	NO	NO	YES	NO	S76-0106-05	L07-2936-05
U.K.	T1	YES	NO	J13-0075-05	NO	NO	NO	NO	NO	NO	NO	S76-0106-05	L07-2936-05
EUROPE	E2	NO	NO	J13-0075-05	NO	NO	NO	NO	NO	NO	NO	S76-0106-05	L07-2936-05

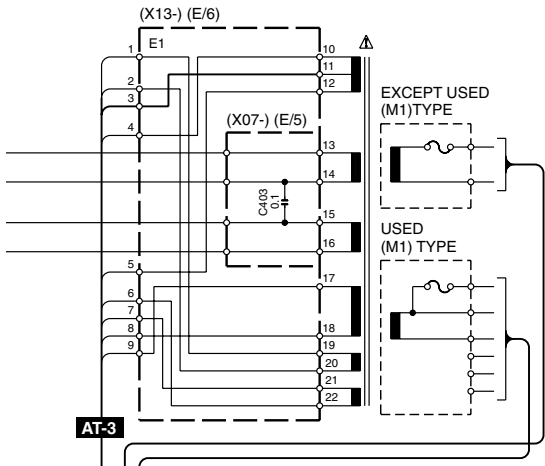

- Q1,2,51,52,101 : 2SC2878(B)
 - Q3,6,53-56,102,103,207,208, 257,258,304,383,384,429 : 2SA992(F,E)
 - Q7,8,57,58,106 : 2SA1123(R,S)
 - Q9-12,59-62,104,105 : 2SC2631(R,S)
 - Q13,14,63,64,107,424,426,530 : 2SA933A(S,Q,R) or 2SA1048(Y,GR) or 2SC1740S(Q,R) or 2SC2458(Y,GR)
 - Q108,405,406,423,425 : DTC124ESA or UN4212
 - Q109,401,427 : TRAIT7P * 5
 - Q201,202,251,252,301 : TRAIT7P * 5
 - Q203,204,253,254,302 : 2SC1845(F,E)
 - Q205,206,255,256,303,381,382 : DTC113ZSA or UN4219
 - Q351-354,402,403 : 2SD2012
 - Q404 : 2SA1110(R,S)
 - Q407 : 2SC2003(L,K)
 - Q408 : 2SC3944A
 - Q421 : 2SA1535A
 - Q422 : DTA143TSA or UN4116
 - Q428
- D1-4,11-14,21,22,53-62,73-82, 92-96,107,108,111-115,205,206, 213-216,252,253,502,509,511-513 : SSS133 or HSS104A
 - D51,52,71,72,91 : 1SS244
 - D100 : RBV-2506LFA
 - D101,102,503-508,510 : S5688B
 - D103,211,212 : MTZJ13(B) or RD13ES(B2)
 - D104 : MTZJ15(B) or RD15ES(B2)
 - D105,106,514 : MTZJ4.7(B) or RD4.7ES(B2)
 - D109,251 : MTZJ5.1(B) or RD5.1ES(B2)
 - D121,122 : MTZJ18(B) or RD18ES(B2)
 - D123,124 : MTZJ20(B) or RD20ES(B2)
 - D201-204 : MTZJ6.2(B) or RD6.2ES(B2)
 - D207,208 : MTZJ24(B) or RD24ES(B2)
 - D209,210 : MTZJ10(B) or RD10ES(B2)
 - D217 : MTZJ2.7(B) or RD2.7ES(B2)

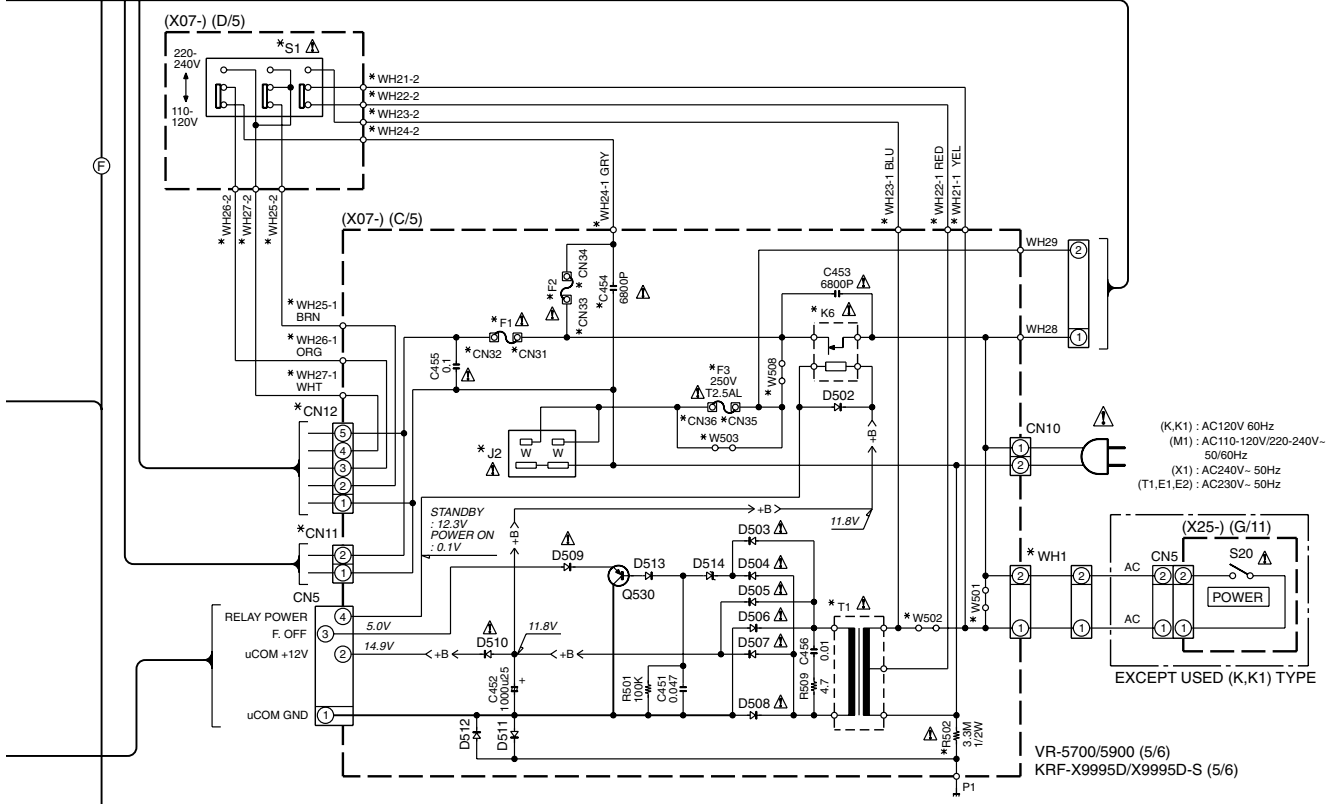
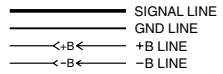

- (K,K1) : AC120V 60Hz
- (M1) : AC110-120V/220-240V-50/60Hz
- (X1) : AC240V - 50Hz
- (T1,E1,E2) : AC230V - 50Hz

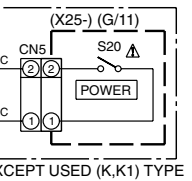

VR-5700/5900 (5/6)
KRF-X9995D/X9995D-S (5/6)

KRF-X9995D/X9995D-S/VR-5700/5900

1

2

3

4

5

6

7

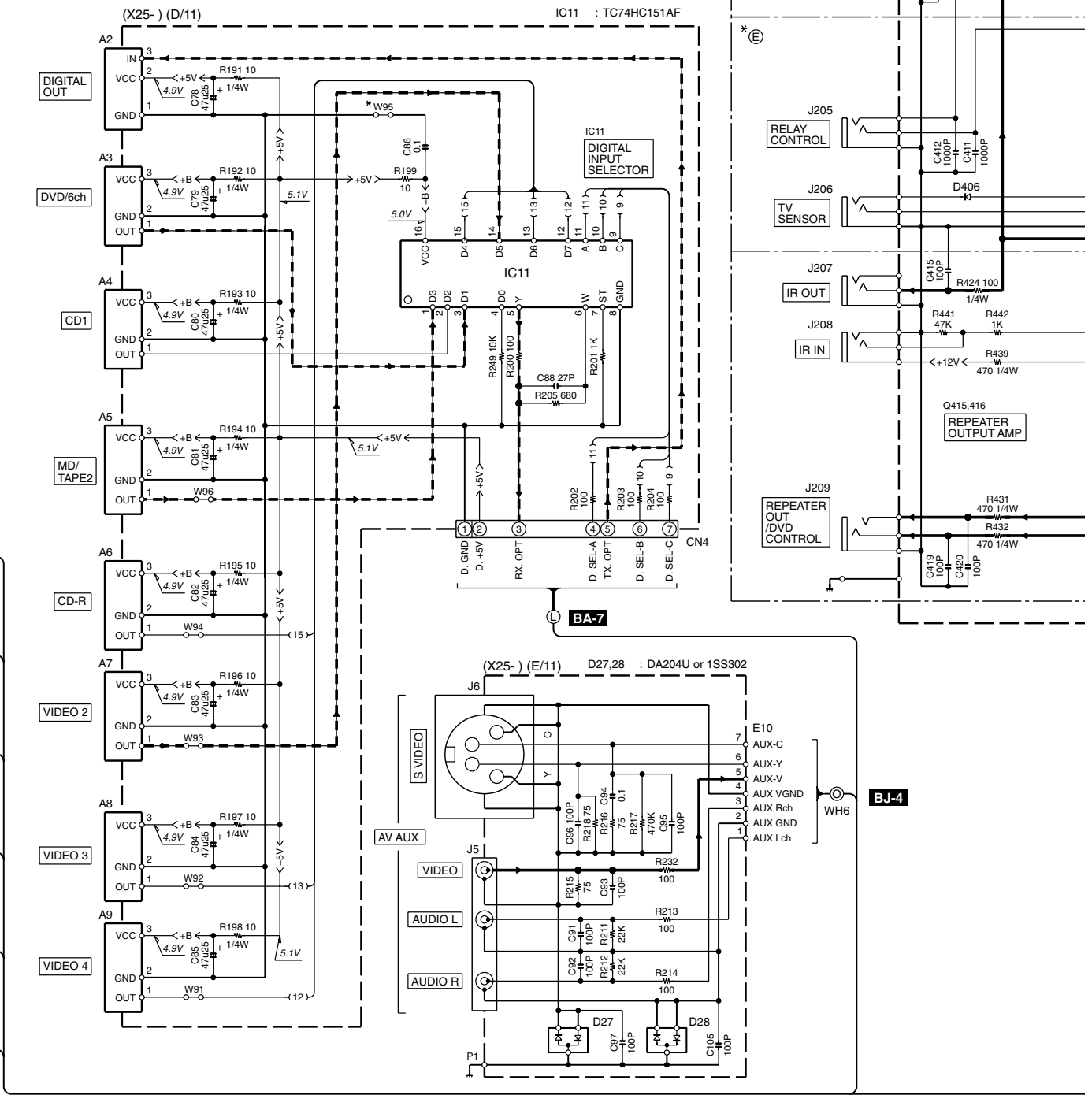

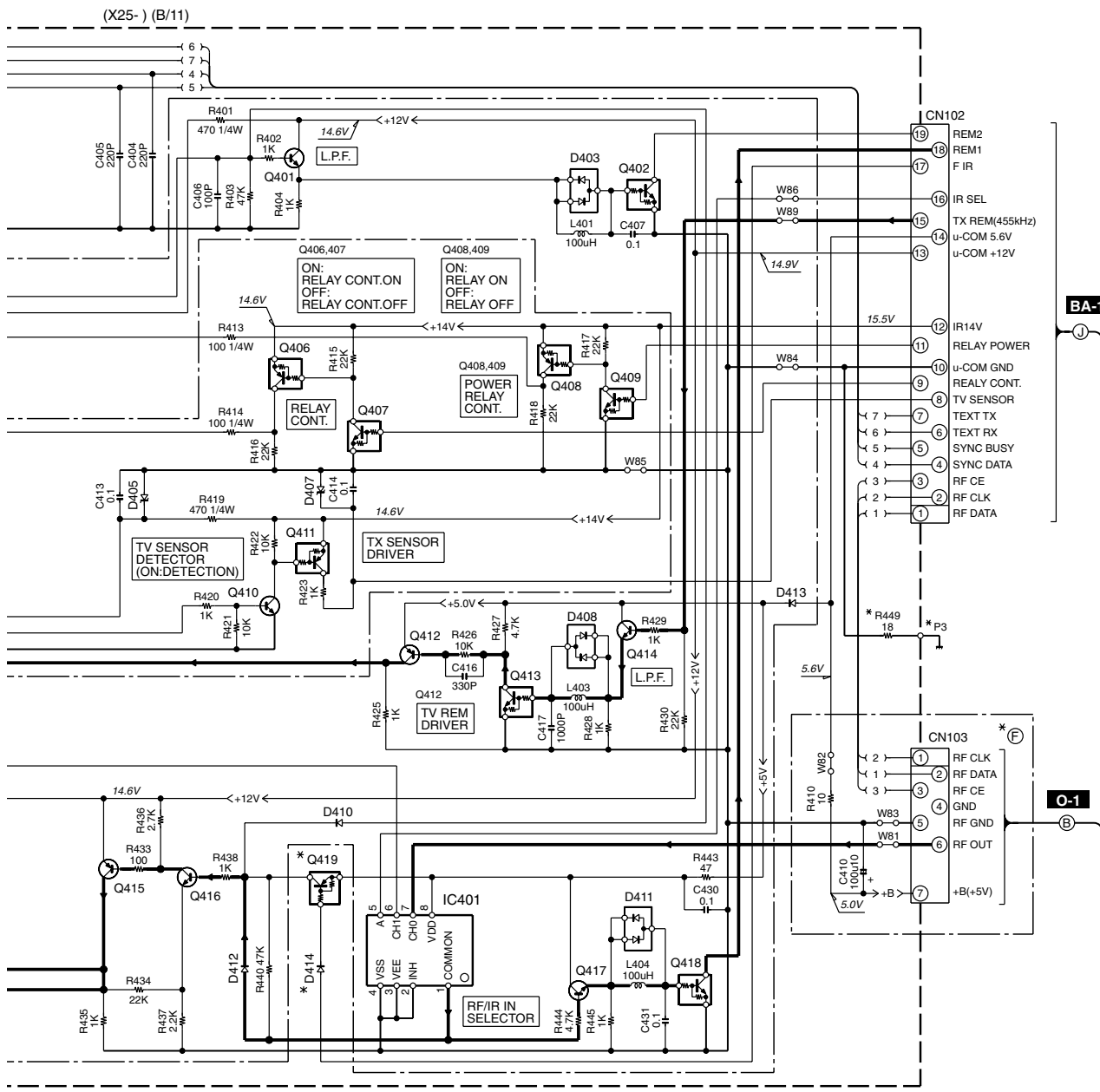

KRF-X9995D (X25-6412-72)

DESTINATION	UNIT No.	(A)	(D)	(E)	(F)	D11	D15-18, 24,25	D414	P3	Q419	R6,82-85, 91,92	R125	R449	S18	W95
EUROPE	E1	2-72	YES	NO	NO	B30-2571-05 (BLUE)	B30-2571-05 (BLUE)	YES	NO	YES	220	YES	NO	YES	NO

KRF-X9995D-S (X25-641X-XX)

DESTINATION	UNIT No.	(A)	(D)	(E)	(F)	D11	D15-18, 24,25	D414	P3	Q419	R6,82-85, 91,92	R125	R449	S18	W95
GENERAL MARKET	M1	0-22	NO	NO	NO	B30-2571-05 (BLUE)	B30-2571-05 (BLUE)	NO	YES	NO	220	YES	YES	NO	NO
AUSTRALIA	X1	0-22	NO	NO	NO	B30-2571-05 (BLUE)	B30-2571-05 (BLUE)	NO	YES	NO	220	YES	YES	NO	NO
U.K.	T1	2-72	YES	NO	NO	B30-2571-05 (BLUE)	B30-2571-05 (BLUE)	YES	NO	YES	220	YES	NO	YES	NO
EUROPE	E2	2-72	YES	YES	NO	B30-2571-05 (BLUE)	B30-2571-05 (BLUE)	YES	NO	YES	220	YES	NO	YES	NO

VR-5700 (X25-6410-11)

DESTINATION	UNIT No.	(A)	(E)	(D)	(F)	D11	D15-18, 24,25	D414	P3	Q419	R6	R82-85, 91,92	R125	R449	S18	W95
U.S.A.	K	0-11	NO	YES	NO	B30-2548-05 (GREEN)	B30-2573-05 (GREEN)	NO	YES	NO	150	270	NO	YES	NO	NO

VR-5900 (X25-6410-12)

DESTINATION	UNIT No.	(A)	(D)	(E)	(F)	D11	D15-18, 24,25	D414	P3	Q419	R6,82-85, 91,92	R125	S18	W95
U.S.A.	K1	0-12	YES	YES	NO	B30-2571-05 (BLUE)	B30-2571-05 (BLUE)	NO	YES	NO	220	YES	YES	NO

- IC401 : TC4W53FU
- Q401,410,414,416,417 : 2SC4081(R,S) or 2SC4116(Y,GR)
- Q402,407,409,413,418 : DTC124EUA or UN5212
- Q406,408,419 : DTA124EUA or UN5112
- Q411 : DTA113ZUA or UN5119
- Q412,415 : 2SA1576A(R,S) or 2SA1586(Y,GR)
- D403,408,411 : DA204U or 1SS302
- D405 : MTZJ5.6(B) or RD5.6ES(B2)
- D406,410,412-414 : 1SS133 or HSS104A
- D407 : MTZJ5.1(B) or RD5.1ES(B2)

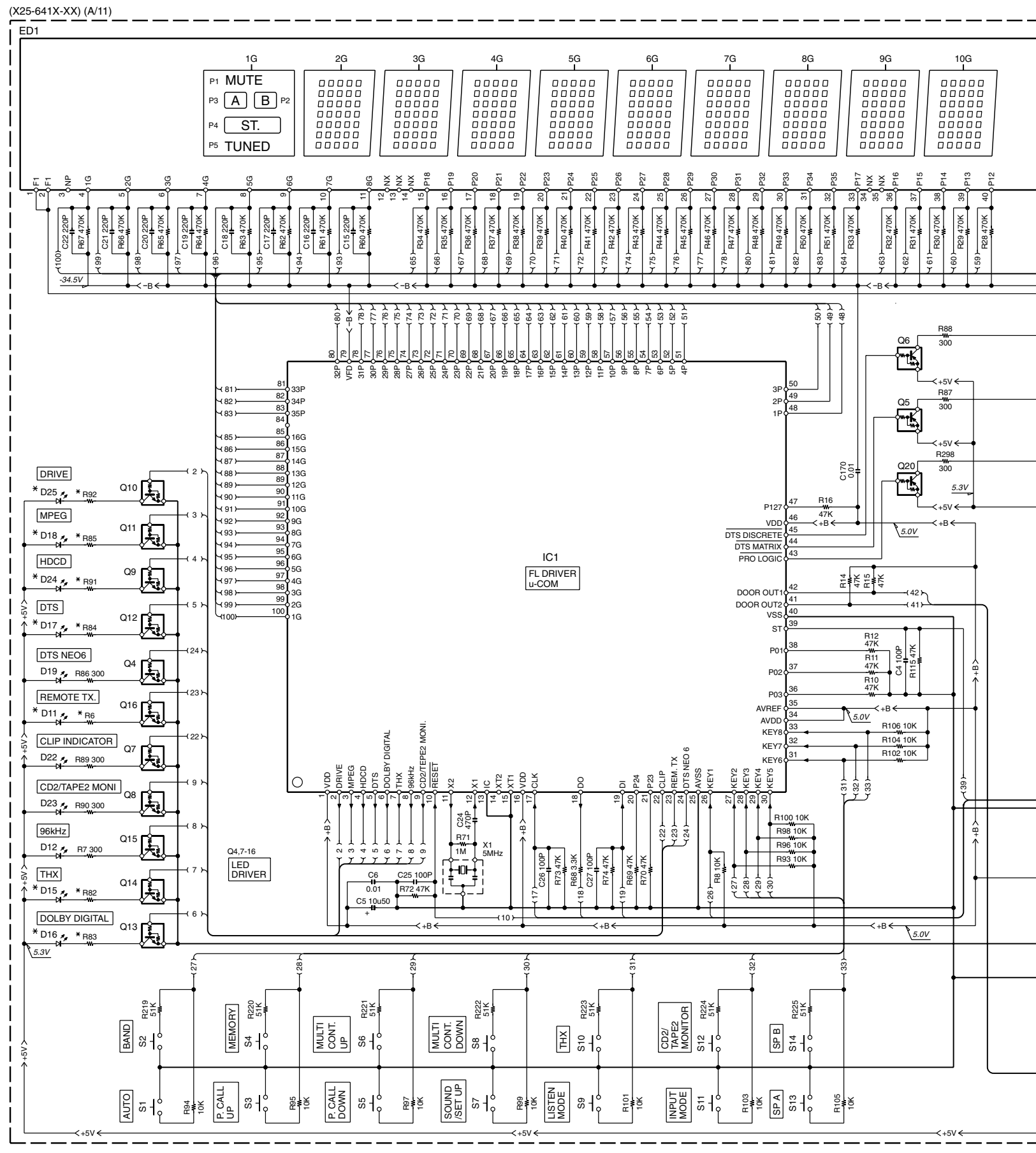

CAUTION: For continued safety, replace safety critical components only with manufacturer's recommended parts (refer to parts list). Δ indicates safety critical components. For continued protection against risk of fire, replace only with same type and rating fuse(s). To reduce the risk of electric shock, leakage-current or resistance measurements shall be carried out (exposed parts are acceptably insulated from the supply circuit) before the appliance is returned to the customer.

The DC voltage is an actual reading measured with a high impedance type voltmeter with a cassette loaded at playback mode. The measurement value may vary depending on the measuring instruments used or on the product. Bias circuit DC voltage is measured while in the record mode.

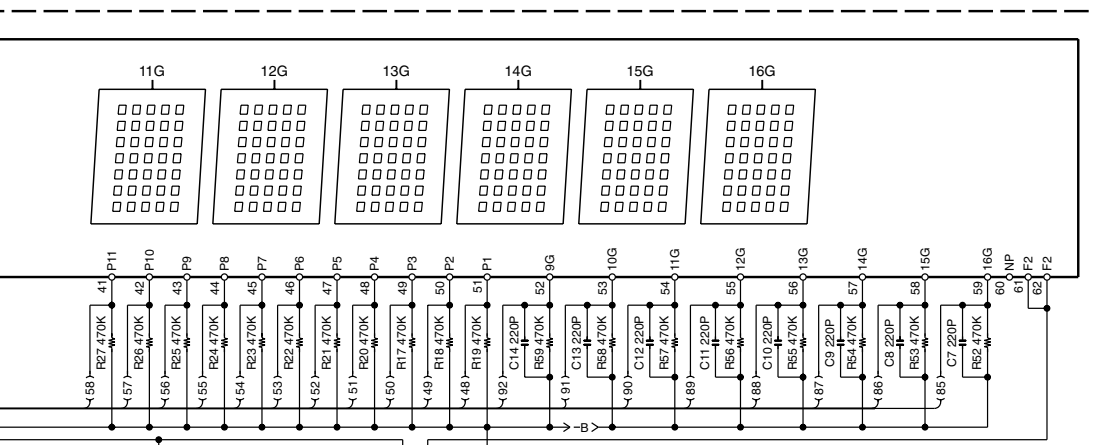

- IC1 : UPD780204-038
- IC2 : TA8409S
- Q1-3 : 2SC3940A(R,S)
- Q4,7-16,21 : DTC124EUA or UN5212
- Q5,6,20 : DTA124EUA or UN5112
- D1,2,29 : MTZJ3.3(B) or RD3.3ES(B2)
- D3-10 : B30-2532-05
- D11 : *
- D12,19-23,30,31 : B30-2430-05
- D13 : MTZJ5.1(B) or RD5.1ES(B2)
- D14 : MTZJ5.6(B) or RD5.6ES(B2)
- D15-18,24,25 : *
- D26 : B30-2597-05
- ED1 : 16-MT-62GK

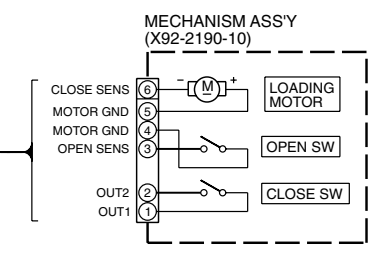
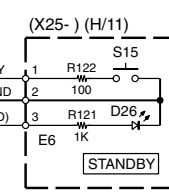
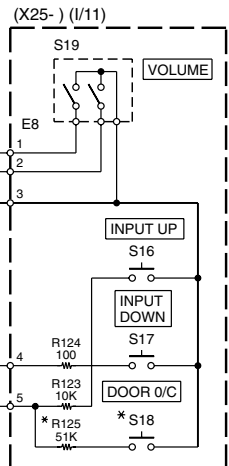
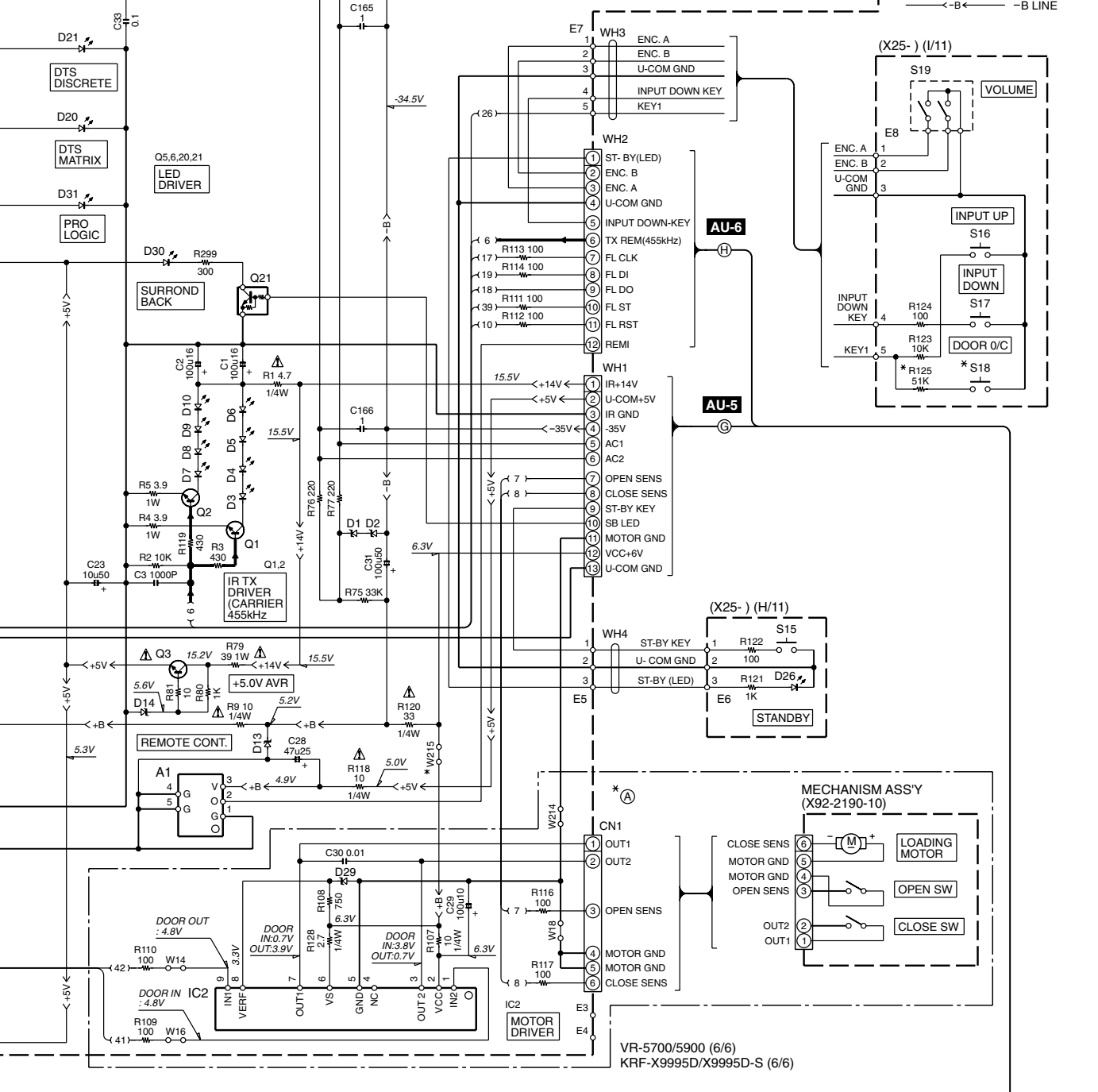
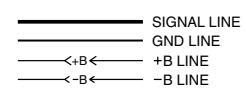

VR-5700/5900 (6/6)
KRF-X9995D/X9995D-S (6/6)

KRF-X9995D/X9995D-S/VR-5700/5900

Y05-4220-10

KENWOOD

EXPLODED VIEW (UNIT)

Parts with exploded numbers larger than 700 are not supplied.

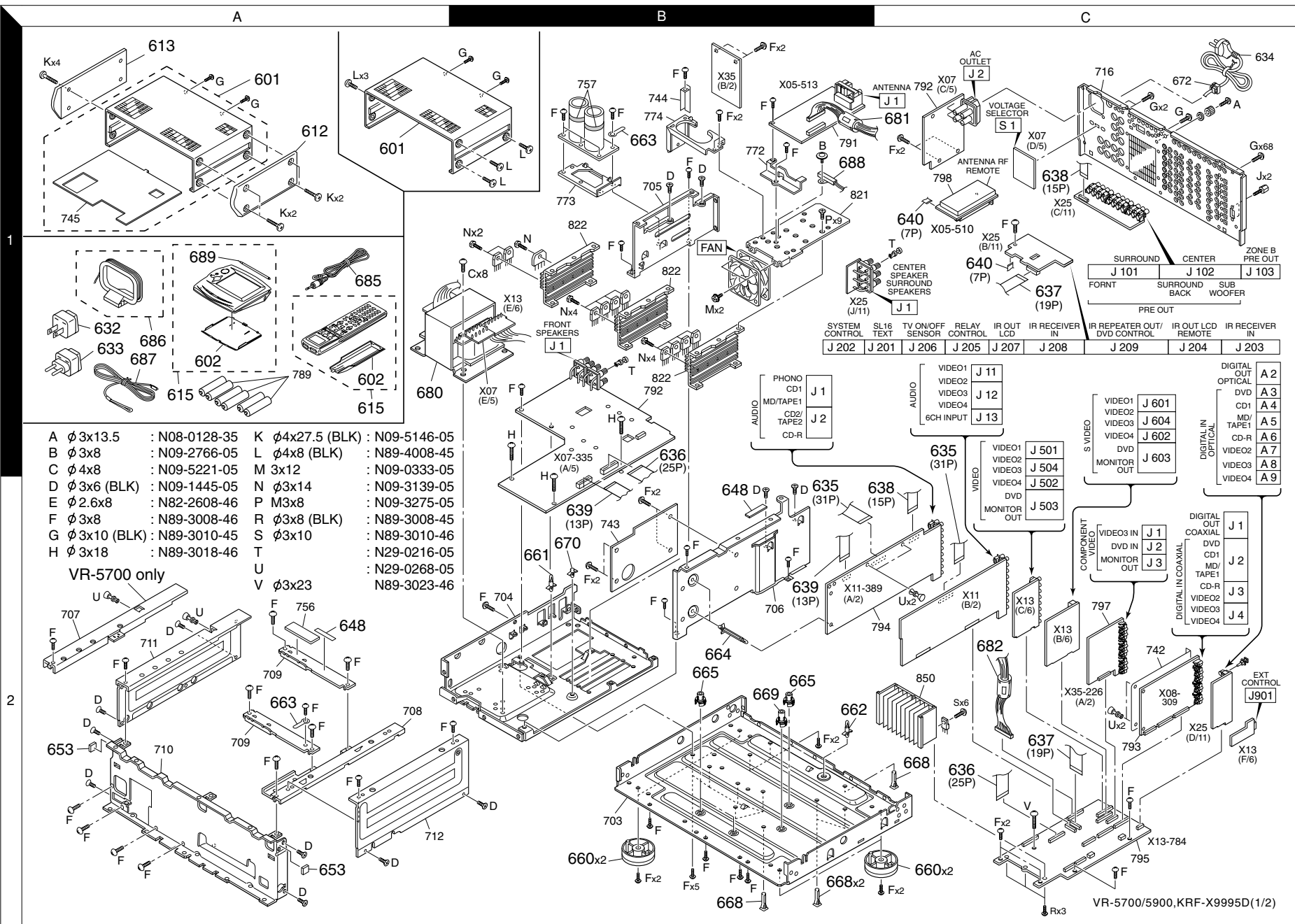

VR-5700/5900, KRF-X9995D(1/2)

Parts with exploded numbers larger than 700 are not supplied.

D

E

F

KRF-X9995D/VR-5900

- D ϕ 3x6 (BLK) : N09-1445-05
- E ϕ 2.6x8 : N82-2608-46
- F ϕ 3x8 : N89-3008-46

REMOTE CONTROL
A1 ED1

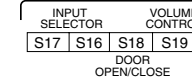
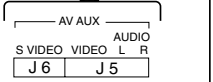
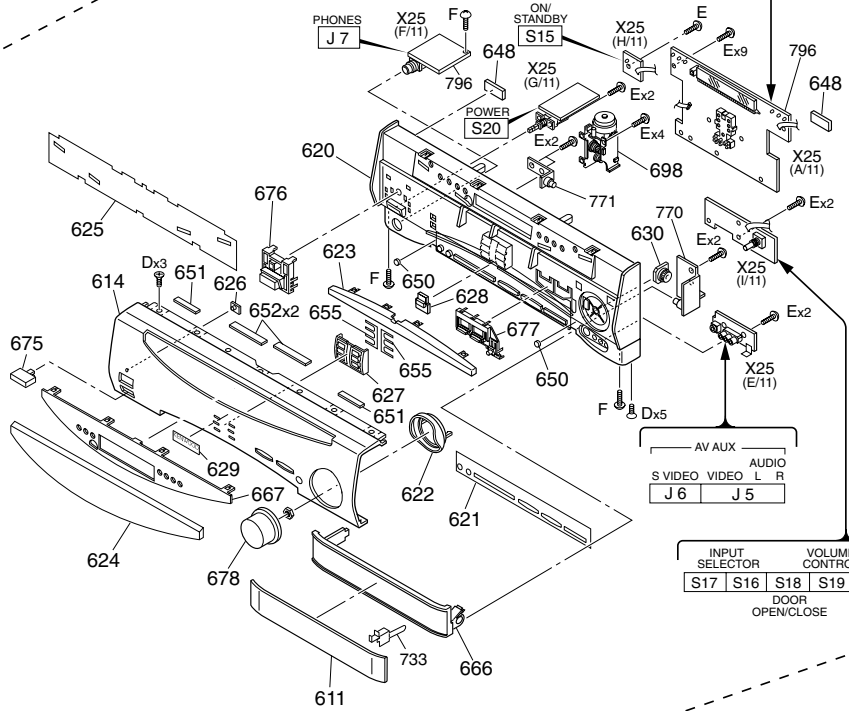
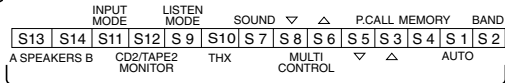

VR-5700

REMOTE CONTROL
A1 ED1

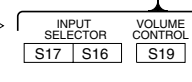
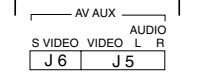
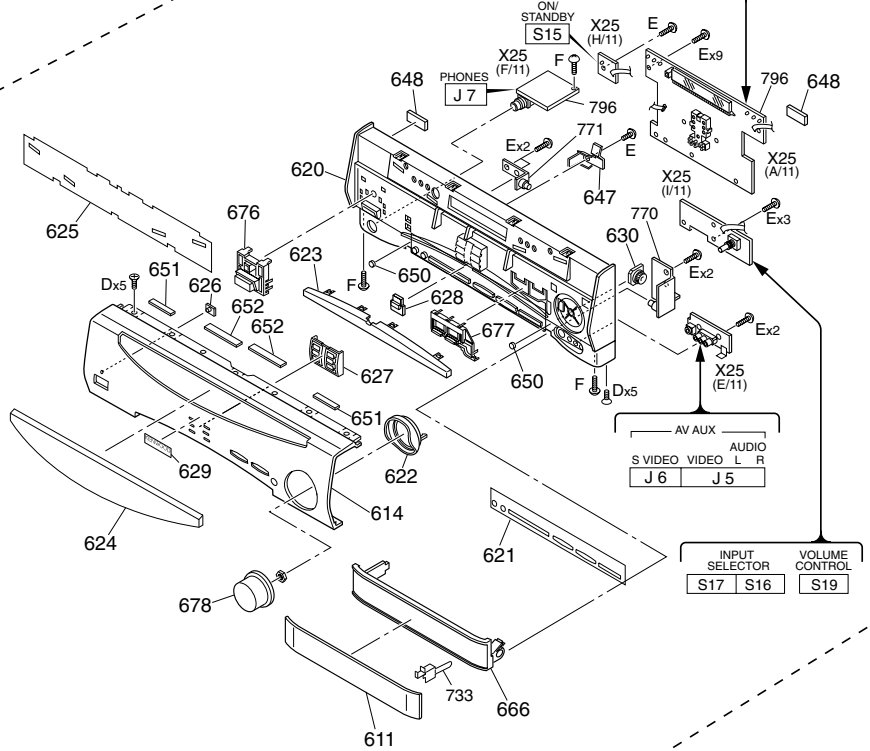
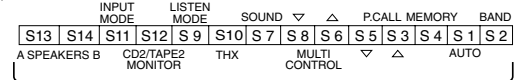

VR-5700/5900, KRF-X9995D (2/2)

EXPLODED VIEW (UNIT)

KRF-X9995D/X9995D-S/VR-5700/5900

* New Parts
Parts without **Parts No.** are not supplied.
Les articles non mentionnés dans le **Parts No.** ne sont pas fournis.
Teile ohne **Parts No.** werden nicht geliefert.

①

Ref. No	Add-ress	New Parts	Parts No.	Description	Desti-nation	Re-marks
KRF-X9995D/VR-5700/VR-5900						
601	1A	*	A01-3804-01	METALLIC CABINET	K	
601	1A	*	A01-3813-01	METALLIC CABINET ASSY	K1E1	
601	1A	*	A01-3814-01	METALLIC CABINET ASSY	M1X1	
601	1A	*	A01-3822-01	METALLIC CABINET ASSY	T1E2	
602	1A		A09-1166-08	BATTERY COVER	K	
602	1A		A09-1177-08	BATTERY COVER	K1E1M1	
602	1A		A09-1177-08	BATTERY COVER	X1T1E2	
611	2D	*	A29-1137-03	PANEL	M1X1	
611	2F	*	A29-1138-03	PANEL	K	
611	2D	*	A29-1139-03	PANEL	T1E2	
611	2D	*	A29-1140-03	PANEL	K1E1	
612	1A		A50-1344-02	SIDE PLATE R	M1X1	
613	1A		A50-1345-02	SIDE PLATE L	M1X1	
614	2F	*	A60-1964-02	PANEL	K	
614	1D	*	A60-1965-02	PANEL	K1	
614	1D	*	A60-2009-02	PANEL	E2	
614	1D	*	A60-2009-02	PANEL	M1X1T1	
614	1D	*	A60-2010-02	PANEL	E1	
615	1A	*	A70-1453-05	REMOTE CONTROL(RC-R0913)	K	
615	1A	*	A70-1456-05	REMOTE CONTROL(RC-R1111)	K1	
615	1A	*	A70-1457-05	REMOTE CONTROL(RC-R1012)	M1X1	
615	1A	*	A70-1458-05	REMOTE CONTROL(RC-R1013)	E1T1E2	
620	1D,1F	*	B01-0543-11	PANEL ESCUTCHEON	KK1E1	
620	1D	*	B01-0544-11	PANEL ESCUTCHEON	E2	
620	1D	*	B01-0544-11	PANEL ESCUTCHEON	M1X1T1	
621	2D,2F	*	B03-3874-03	DRESSING PLATE	KK1	
621	2D	*	B03-3875-03	DRESSING PLATE	E2	
621	2D	*	B03-3875-03	DRESSING PLATE	M1X1T1	
621	2D	*	B03-3877-03	DRESSING PLATE	E1	
622	2D		B07-2495-04	ESCUTCHEON	E2	
622	2D		B07-2495-04	ESCUTCHEON	M1X1T1	
622	2D,2F		B07-2496-04	ESCUTCHEON	KK1E1	
623	1D,1F		B10-3570-03	FRONT GLASS		
624	2E	*	B10-3639-02	FRONT GLASS	K	
624	2D	*	B10-3640-02	FRONT GLASS	K1E1M1	
624	2D	*	B10-3640-02	FRONT GLASS	X1T1E2	
625	1D		B11-1505-03	COLOR FILTER	K1E1M1	
625	1D		B11-1505-03	COLOR FILTER	X1T1E2	
625	1E	*	B11-1528-03	COLOR FILTER	K	
626	1D,1E		B12-0390-04	INDICATOR		
627	2D,2F		B12-0391-14	INDICATOR		
628	1D,1F		B12-0392-14	INDICATOR		
629	2D,2E	*	B43-0322-04	KENWOOD BADGE	KK1	
-			B46-0096-53	WARRANTY CARD	X1	
-			B46-0310-03	WARRANTY CARD	E1T1E2	
-		*	B46-0331-03	WARRANTY CARD	KK1	
-			B46-0347-03	WARRANTY CARD	KK1	
-			B46-0350-00	QUESTIONNAIRE CARD	T1	
-			B46-0351-00	QUESTIONNAIRE CARD	KK1	
-			B58-0945-03	CAUTION CARD	T1	
-			B58-0965-13	CAUTION CARD (PL)	X1T1	
-			B58-0966-13	CAUTION CARD (PL)	E1M1E2	

L : Scandinavia K : USA P : Canada R : Mexico C : China I : Malaysia
Y : PX(Far East,Hawaii) T : England E : Europe G : Germany V : China(Shanghai)
Y : AAFES(Europe) X : Australia Q : Russia H : Korea M : Other Areas Δ indicates safety critical components .

* New Parts
Parts without **Parts No.** are not supplied.
Les articles non mentionnés dans le **Parts No.** ne sont pas fournis.
Teile ohne **Parts No.** werden nicht geliefert.

②

Ref. No	Add-ress	New Parts	Parts No.	Description	Desti-nation	Re-marks
-			B58-0967-03	CAUTION CARD (PL)	KK1	
-		*	B60-4861-00	INSTRUCTION MANUAL(EN1)	K	
-		*	B60-4862-00	INSTRUCTION MANUAL(FR1)	K	
-		*	B60-4872-00	INSTRUCTION MANUAL(EN2)	K	
-		*	B60-4873-00	INSTRUCTION MANUAL(FR2)	K	
-		*	B60-4883-00	INSTRUCTION MANUAL(EN1)	K1	
-		*	B60-4884-00	INSTRUCTION MANUAL(FR1)	K1	
-		*	B60-4885-00	INSTRUCTION MANUAL(EN1)	M1X1T1	
-		*	B60-4886-00	INSTRUCTION MANUAL(FR1)	E2	
-		*	B60-4887-00	INSTRUCTION MANUAL(GE1)	E1E2	
-		*	B60-4888-00	INSTRUCTION MANUAL(NE1)	E2	
-		*	B60-4889-00	INSTRUCTION MANUAL(IT1)	E2	
-		*	B60-4890-00	INSTRUCTION MANUAL(ES1)	E2	
-		*	B60-4891-00	INSTRUCTION MANUAL(TC1)	M1	
-		*	B60-4892-00	INSTRUCTION MANUAL(AR1)	M1	
-		*	B60-5016-00	INSTRUCTION MANUAL(EN2)	K1	
-		*	B60-5017-00	INSTRUCTION MANUAL(FR2)	K1	
-		*	B60-5018-00	INSTRUCTION MANUAL(EN2)	M1X1T1	
-		*	B60-5019-00	INSTRUCTION MANUAL(FR2)	E2	
-		*	B60-5020-00	INSTRUCTION MANUAL(GE2)	E1E2	
-		*	B60-5021-00	INSTRUCTION MANUAL(NE2)	E2	
-		*	B60-5022-00	INSTRUCTION MANUAL(IT2)	E2	
-		*	B60-5023-00	INSTRUCTION MANUAL(ES2)	E2	
-		*	B60-5024-00	INSTRUCTION MANUAL(TC2)	M1	
-		*	B60-5025-00	INSTRUCTION MANUAL(AR2)	M1	
630	1E		D39-0334-15	DAMPER	K1E1M1	
630	1E		D39-0334-15	DAMPER	X1T1E2	
630	1F		D39-0347-05	DAMPER	K	
Δ 632	1A	*	E03-0382-05	AC PLUG ADAPTER(WA-6)	M1	
Δ 633	1A	*	E03-0383-05	AC PLUG ADAPTER(WA-9C)	M1	
Δ 634	1C		E30-2790-05	AC POWER CORD	X1	
Δ 634	1C		E30-2791-05	AC POWER CORD	T1	
Δ 634	1C		E30-2943-05	AC POWER CORD	E1E2	
Δ 634	1C	*	E30-7215-05	AC POWER CORD	KK1	
Δ 634	1C	*	E30-7225-05	AC POWER CORD	M1	
635	2B,1C	*	E35-2757-05	FLAT CABLE 31P		
636	2B,2C	*	E35-2758-05	FLAT CABLE 25P		
637	1C,2C	*	E35-2759-05	FLAT CABLE 19P		
638	1C,2C	*	E35-2760-05	FLAT CABLE 15P		
639	2B	*	E35-2761-05	FLAT CABLE 13P		
640	1C	*	E35-2762-05	FLAT CABLE 7P	KK1	
647	1F		G02-1701-04	FLAT SPRING		
648	1D,1E		G10-0541-04	NON-WOVEN FABRIC,10X50		
650	1D,1F		G11-2719-04	CUSHION DOOR		
651	1D,1F		G11-2730-04	SOFT TAPE		
652	1D,1E		G11-2731-04	SOFT TAPE BRIDGE		
653	2A		G11-2743-14	CUSHION SUB PANEL	KK1E1	
653	2A		G11-2743-14	CUSHION SUB PANEL	T1E2	
655	1D,2D		G11-2762-04	CUSHION INDICATOR	K1E1M1	
655	1D,2D		G11-2762-04	CUSHION INDICATOR	X1T1E2	
-		*	H10-7638-22	POLYSTYRENE FOAMED FIXTURE,L	M1X1	
-		*	H10-7639-22	POLYSTYRENE FOAMED FIXTURE,R	M1X1	
-			H10-7664-12	POLYSTYRENE FOAMED FIXTURE,RC	K1E1M1	
-			H10-7664-12	POLYSTYRENE FOAMED FIXTURE,RC	X1T1E2	

L : Scandinavia K : USA P : Canada R : Mexico C : China I : Malaysia
Y : PX(Far East,Hawaii) T : England E : Europe G : Germany V : China(Shanghai)
Y : AAFES(Europe) X : Australia Q : Russia H : Korea M : Other Areas Δ indicates safety critical components .

* New Parts
Parts without **Parts No.** are not supplied.
Les articles non mentionnés dans le **Parts No.** ne sont pas fournis.
Teile ohne **Parts No.** werden nicht geliefert.

3

Ref. No	Add-ress	New Parts	Parts No.	Description	Desti-nation	Re-marks
-	-	*	H10-7755-12	POLYSTYRENE FOAMED FIXTURE,L	KK1E1	
-	-	*	H10-7755-12	POLYSTYRENE FOAMED FIXTURE,L	T1E2	
-	-	*	H10-7756-12	POLYSTYRENE FOAMED FIXTURE,R	KK1E1	
-	-	*	H10-7756-12	POLYSTYRENE FOAMED FIXTURE,R	T1E2	
-	-	*	H11-0099-04	POLYSTYRENE FOAMED BOARD	E1M1X1	
-	-		H11-0099-04	POLYSTYRENE FOAMED BOARD	T1E2	
-	-		H12-3440-04	PACKING FIXTURE	K1E1M1	
-	-		H12-3440-04	PACKING FIXTURE	X1T1E2	
-	-	*	H12-3527-04	PACKING FIXTURE	KK1E1	
-	-	*	H12-3527-04	PACKING FIXTURE	T1E2	
-	-	*	H13-0050-04	CARTON BOARD	M1E2	
-	-	*	H13-0330-14	CARTON BOARD	K	
-	-	*	H13-0342-04	CARTON BOARD	K	
-	-	*	H13-0343-04	CARTON BOARD	K1	
-	-	*	H20-0617-04	PROTECTION COVER	M1	
-	-	*	H21-0388-04	PROTECTION SHEET	E2	
-	-	*	H21-0388-04	PROTECTION SHEET	M1X1T1	
-	-	*	H25-0232-04	PROTECTION BAG (235X350X0.03)	KK1E1	
-	-	*	H25-0232-04	PROTECTION BAG (235X350X0.03)	X1	
-	-	*	H25-0232-04	PROTECTION BAG	M1E2	
-	-	*	H25-0651-04	PROTECTION BAG	T1	
-	-	*	H25-0692-04	PROTECTION BAG	KK1E1	
-	-	*	H25-0692-04	PROTECTION BAG	T1E2	
-	-	*	H25-1671-04	PROTECTION BAG	X1	
-	-	*	H50-3946-04	ITEM CARTON CASE	K	
-	-	*	H50-3947-04	ITEM CARTON CASE	K1	
-	-	*	H50-3948-04	ITEM CARTON CASE	M1	
-	-	*	H50-3949-04	ITEM CARTON CASE	X1	
-	-	*	H50-4075-04	ITEM CARTON CASE	E1	
-	-	*	H50-4171-04	ITEM CARTON CASE	E2	
-	-	*	H50-4172-04	ITEM CARTON CASE	T1	
660	2B,2C		J02-1467-03	FOOT (D=60,H=21.5)		
661	2B		J19-5910-05	UNIT HOLDER X07,H=8.4		
662	2B		J19-5911-05	UNIT HOLDER X07,H=11.6		
663	2A,1B		J19-0306-05	LEAD HOLDER ELECTRO-C		
664	2B		J19-5919-05	UNIT HOLDER X11,H=36.8		
665	2B		J19-6002-04	UNIT HOLDER X07		
666	2D		J19-6053-12	HOLDER DOOR	E2	
666	2D		J19-6053-12	HOLDER DOOR	M1X1T1	
666	2D,2F		J19-6068-12	HOLDER DOOR	KK1E1	
667	2D	*	J19-6181-02	HOLDER	K1E1M1	
667	2D	*	J19-6181-02	HOLDER	X1T1E2	
668	2B,2C	*	J19-6163-05	HOLDER H=16		
669	2B	*	J19-6203-04	UNIT HOLDER H=16.4		
670	2B	*	J19-6080-05	UNIT HOLDER X07,FAN		
Δ 672	1C	*	J42-0083-05	POWER CORD BUSHING	X1T1	
Δ 672	1C		J42-0157-05	POWER CORD BUSHING	KK1E1	
Δ 672	1C		J42-0157-05	POWER CORD BUSHING	M1E2	
-	-		J61-0307-05	WIRE BAND		
675	2D		K27-2388-04	KNOB (BUTTON)	E2	
675	2D		K27-2388-04	KNOB (BUTTON)	M1X1T1	
675	2D		K27-2398-04	KNOB (BUTTON)	E1	
676	1D		K29-7727-04	KNOB	E2	
676	1D		K29-7727-04	KNOB	M1X1T1	

L : Scandinavia K : USA P : Canada R : Mexico C : China I : Malaysia
Y : PX(Far East,Hawaii) T : England E : Europe G : Germany V : China(Shanghai)
Y : AAFES(Europe) X : Australia Q : Russia H : Korea M : Other Areas Δ indicates safety critical components .

* New Parts
Parts without **Parts No.** are not supplied.
Les articles non mentionnés dans le **Parts No.** ne sont pas fournis.
Teile ohne **Parts No.** werden nicht geliefert.

4

Ref. No	Add-ress	New Parts	Parts No.	Description	Desti-nation	Re-marks
676	1D,1E		K29-7729-04	KNOB	KK1E1	
677	2D		K29-7728-13	KNOB	E2	
677	2D		K29-7728-13	KNOB	M1X1T1	
677	1F		K29-7740-13	KNOB	K	
677	2D	*	K29-7953-03	KNOB	K1E1	
678	2D	*	K29-7742-04	KNOB	E2	
678	2D	*	K29-7742-04	KNOB	M1X1T1	
678	2D,2E	*	K29-7743-04	KNOB	KK1E1	
Δ 680	1A	*	L07-2946-05	POWER TRANSFORMER	KK1	
Δ 680	1A	*	L07-2947-05	POWER TRANSFORMER	E1T1E2	
Δ 680	1A	*	L07-2948-05	POWER TRANSFORMER	M1	
Δ 680	1A	*	L07-2949-05	POWER TRANSFORMER	X1	
681	1B	*	L92-0533-05	FERRITE CORE LARGE		
682	2C	*	L92-0531-05	FERRITE CORE SMALL		
685	1A		T90-0850-05	ANTENNA ASSY	KK1	
686	1A		T90-0852-05	LOOP ANTENNA		
687	1A		T90-0855-05	LEAD WIRE ANTENNA		
688	1B	*	DP40203SG270	THERMISTOR		
689	1A		W01-0976-08	PEN	E1E2T1	
689	1A		W01-0976-08	PEN	K1M1X1	
698	1E		X92-2190-10	MECHANISM ASSY	K1E1M1	
698	1E		X92-2190-10	MECHANISM ASSY	X1T1E2	
RF-RC (X05-5100-11) U.S.A only						
C1	.2		CC73GCH1H100D	CHIP C	10PF	D
C5			CK73GB1E223K	CHIP C	0.022UF	K
C6			CC73GCH1H221J	CHIP C	220PF	J
C7			CC73GCH1H100D	CHIP C	10PF	D
C8			CK73GB1H102K	CHIP C	1000PF	K
C9			C93-0037-05	CERAMIC	10UF	10WV
C10			CK73GB1H102K	CHIP C	1000PF	K
C11			CC73GCH1H040C	CHIP C	4.0PF	C
C12			CC73GCH1H100D	CHIP C	10PF	D
C13			CC73GCH1H040C	CHIP C	4.0PF	C
C14			CC73GCH1H010C	CHIP C	1.0PF	C
C15			CC73GCH1H050C	CHIP C	5.0PF	C
C16			CK73GB1E223K	CHIP C	0.022UF	K
C17			CC73GCH1H221J	CHIP C	220PF	J
C18			CC73GCH1H100D	CHIP C	10PF	D
C19			CC73GCH1H471J	CHIP C	470PF	J
C20			C93-0037-05	CERAMIC	10UF	10WV
C21			CK73GB1H102K	CHIP C	1000PF	K
C22	.23		CC73GCH1H150J	CHIP C	15PF	J
C24			CK73GB1H102K	CHIP C	1000PF	K
C25			CK73GB1E103K	CHIP C	0.010UF	K
C26			CK73GF1A474Z	CHIP C	0.47UF	Z
C27			C93-0036-05	CHIP-C	4.7UF	Z
C28			CK73GB1E103K	CHIP C	0.010UF	K
C29			CC73GCH1H101J	CHIP C	100PF	J
C30			CK73GB1E103K	CHIP C	0.010UF	K
C31			C93-0037-05	CERAMIC	10UF	10WV
C32			CK73GB1C473K	CHIP C	0.047UF	K
C33			C93-0036-05	CHIP-C	4.7UF	Z

L : Scandinavia K : USA P : Canada R : Mexico C : China I : Malaysia
Y : PX(Far East,Hawaii) T : England E : Europe G : Germany V : China(Shanghai)
Y : AAFES(Europe) X : Australia Q : Russia H : Korea M : Other Areas Δ indicates safety critical components .

PARTS LIST

KRF-X9995D/X9995D-S/VR-5700/5900

* New Parts
Parts without **Parts No.** are not supplied.
Les articles non mentionnés dans le **Parts No.** ne sont pas fournis.
Teile ohne **Parts No.** werden nicht geliefert.

5

Ref. No	Add-ress	New Parts	Parts No.	Description	Desti-nation	Re-marks
C34			CC73GCH1H471J	CHIP C 470PF	J	
C35			CK73GB1E103K	CHIP C 0.010UF	K	
C36			CK73GF1C224Z	CHIP C 0.22UF	Z	
C37			CC73GCH1H100D	CHIP C 10PF	D	
C38			CK73GB1H472K	CHIP C 4700PF	K	
C39			CC73GCH1H331J	CHIP C 330PF	J	
C40			CK73GB1E103K	CHIP C 0.010UF	K	
C41			C93-0036-05	CHIP-C 4.7UF	Z	
C42			C93-0037-05	CERAMIC 10UF	10WV	
C43			C93-0039-05	CERAMIC 22UF	10WV	
CN1			E40-8530-05	FLAT CABLE CONNECTOR		
J1			E11-0904-05	MINIATURE PHONE JACK(STEREO MI)		
CF1			L72-0626-05	CERAMIC FILTER		
L1		*	L79-1269-05	LC FILTER		
L2			L40-1585-67	SMALL FIXED INDUCTOR(150N,J,20)		
L3			L32-1021-05	FM OSCILLATING COIL		
L4			L40-1085-67	SMALL FIXED INDUCTOR(100N,J,20)		
X1			L77-2274-05	CRYSTAL RESONATOR		
R1			RK73GB1J431J	CHIP R 430	J 1/16W	
R2			RK73GB1J120J	CHIP R 12	J 1/16W	
R3			RK73GB1J431J	CHIP R 430	J 1/16W	
R10			RK73GB1J331J	CHIP R 330	J 1/16W	
R11			RK73GB1J391J	CHIP R 390	J 1/16W	
R12			RK73GB1J100J	CHIP R 10	J 1/16W	
R13			RK73GB1J470J	CHIP R 47	J 1/16W	
R14			RK73GB1J473J	CHIP R 47K	J 1/16W	
R15			RK73GB1J2R2J	CHIP R 2.2	J 1/16W	
R16			RK73GB1J100J	CHIP R 10	J 1/16W	
R17			RK73GB1J101J	CHIP R 100	J 1/16W	
R18			RK73GB1J184J	CHIP R 180K	J 1/16W	
R19			RK73GB1J471J	CHIP R 470	J 1/16W	
R20 ,21			RK73GB1J100J	CHIP R 10	J 1/16W	
R22 -24			RK73GB1J102J	CHIP R 1.0K	J 1/16W	
R25			RK73GB1J472J	CHIP R 4.7K	J 1/16W	
R26			RK73GB1J101J	CHIP R 100	J 1/16W	
R27			RK73GB1J152J	CHIP R 1.5K	J 1/16W	
R28			RK73GB1J681J	CHIP R 680	J 1/16W	
R29 -31			RK73GB1J102J	CHIP R 1.0K	J 1/16W	
R32			RK73GB1J152J	CHIP R 1.5K	J 1/16W	
R33			RK73GB1J102J	CHIP R 1.0K	J 1/16W	
R34 ,35			RK73GB1J222J	CHIP R 2.2K	J 1/16W	
R36 ,37			RK73GB1J101J	CHIP R 100	J 1/16W	
R38			RK73GB1J222J	CHIP R 2.2K	J 1/16W	
R39			RK73GB1J472J	CHIP R 4.7K	J 1/16W	
R40			RK73GB1J104J	CHIP R 100K	J 1/16W	
R41			RK73GB1J472J	CHIP R 4.7K	J 1/16W	
R42			RK73GB1J101J	CHIP R 100	J 1/16W	
R43 ,44			RK73GB1J103J	CHIP R 10K	J 1/16W	
R45			RK73GB1J105J	CHIP R 1.0M	J 1/16W	
R46			RK73GB1J562J	CHIP R 5.6K	J 1/16W	
R47 -49			RK73GB1J472J	CHIP R 4.7K	J 1/16W	
R50			RK73GB1J101J	CHIP R 100	J 1/16W	
R51			RK73GB1J473J	CHIP R 47K	J 1/16W	

L : Scandinavia K : USA P : Canada R : Mexico C : China I : Malaysia
Y : PX(Far East,Hawaii) T : England E : Europe G : Germany V : China(Shanghai)
Y : AAFES(Europe) X : Australia Q : Russia H : Korea M : Other Areas Δ indicates safety critical components .

* New Parts
Parts without **Parts No.** are not supplied.
Les articles non mentionnés dans le **Parts No.** ne sont pas fournis.
Teile ohne **Parts No.** werden nicht geliefert.

6

Ref. No	Add-ress	New Parts	Parts No.	Description	Desti-nation	Re-marks
R52			RK73GB1J103J	CHIP R 10K	J 1/16W	
R53			RK73GB1J472J	CHIP R 4.7K	J 1/16W	
R54			RK73GB1J101J	CHIP R 100	J 1/16W	
D1 ,2			MA111	DIODE		
D3			KV1832E	VARIABLE CAPACITANCE DIODE		
D4			MA111	DIODE		
IC1			UPC1687G	ANALOGUE IC		
IC2			LV2105V	MOS-IC		
IC3			UPC2748T-E3	ANALOGUE IC		
Q3			2SC5065(O,Y)	TRANSISTOR		
Q4 -6			2SC4178(F13,14)	TRANSISTOR		
Q7			2SA1576A(R,S)	TRANSISTOR		
Q7			2SB1218A(Q,R)	TRANSISTOR		
Q8 -10			2SC4081(R,S)	TRANSISTOR		
Q8 -10			2SD1819A(Q,R)	TRANSISTOR		
Q11 ,12			2SA1576A(R,S)	TRANSISTOR		
Q11 ,12			2SB1218A(Q,R)	TRANSISTOR		
TUNER (X05-5130-13)						
C1			CK73FB1H332K	CHIP C 3300PF	K	
C2			CK73FB1H103K	CHIP C 0.010UF	K	E2
C2			CK73FB1H103K	CHIP C 0.010UF	K	K1E1T1
C3			CK73FB1H103K	CHIP C 0.010UF	K	
C5 ,6			CK73FB1H103K	CHIP C 0.010UF	K	
C7			CE04KW1C470M	ELECTRO 47UF	16WV	
C10			CE04KW1C470M	ELECTRO 47UF	16WV	
C11 ,12			CK73FB1H473K	CHIP C 0.047UF	K	
C14			CE04KW1H100M	ELECTRO 10UF	50WV	
C15			CE04KW1H010M	ELECTRO 1.0UF	50WV	
C16			CE04RW1HR47M	ELECTRO 0.47UF	50WV	
C17			CE04KW1H010M	ELECTRO 1.0UF	50WV	
C18			CC73FCH1H470J	CHIP C 47PF	J	
C19			CE04RW1A100M	ELECTRO 10UF	10WV	
C20			CK73FB1H473K	CHIP C 0.047UF	K	
C21			CE04RW1V3R3M	ELECTRO 3.3UF	35WV	
C22			CK73FB1H473K	CHIP C 0.047UF	K	
C23			CE04KW1H100M	ELECTRO 10UF	50WV	
C24			CC73FCH1H331J	CHIP C 330PF	J	
C25			CC73FCH1H181J	CHIP C 180PF	J	KK1E1
C25			CC73FCH1H181J	CHIP C 180PF	J	T1E2
C25			CC73FCH1H331J	CHIP C 330PF	J	M1X1
C26			CK73FB1H183K	CHIP C 0.018UF	K	
C27			CE04HW1E4R7M	NP-ELEC 4.7UF	25WV	
C28 ,29			CE04KW1H2R2M	ELECTRO 2.2UF	50WV	
C30 ,31			CK73FB1H223K	CHIP C 0.022UF	K	E1M1X1
C30 ,31			CK73FB1H223K	CHIP C 0.022UF	K	T1E2
C30 ,31			CK73FB1H333K	CHIP C 0.033UF	K	KK1
C32			CE04KW1H4R7M	ELECTRO 4.7UF	50WV	
C33 ,34			CK73FB1H103K	CHIP C 0.010UF	K	M1
C36			CK73FB1H103K	CHIP C 0.010UF	K	
C37 ,38			CE04KW1H100M	ELECTRO 10UF	50WV	
C41			CC73FCH1H470J	CHIP C 47PF	J	
C42			CC73FCH1H270J	CHIP C 27PF	J	
C43			CC73FCH1H220J	CHIP C 22PF	J	
C44			CC73FCH1H471J	CHIP C 470PF	J	

L : Scandinavia K : USA P : Canada R : Mexico C : China I : Malaysia
Y : PX(Far East,Hawaii) T : England E : Europe G : Germany V : China(Shanghai)
Y : AAFES(Europe) X : Australia Q : Russia H : Korea M : Other Areas Δ indicates safety critical components .

* New Parts
 Parts without **Parts No.** are not supplied.
 Les articles non mentionnés dans le **Parts No.** ne sont pas fournis.
 Teile ohne **Parts No.** werden nicht geliefert.

7

Ref. No	Add-ress	New Parts	Parts No.	Description	Desti-nation	Re-marks
C45			CC73FCH1H220J	CHIP C 22PF	J	
C46			CE04KW1H100M	ELECTRO 10UF 50WV	J	
C47			CK73FB1H102K	CHIP C 1000PF	K	
C48			CE04KW1C470M	ELECTRO 47UF 16WV	J	
C49			CE04KW1H2R2M	ELECTRO 2.2UF 50WV	J	
C50			CC73FCH1H101J	CHIP C 100PF	J	
C51			CC73FCH1H471J	CHIP C 470PF	J	
C52			CC73FCH1H101J	CHIP C 100PF	J	
C70 ,71			CK73FB1H822K	CHIP C 8200PF	K	E1T1E2
C72			CE04KW1H010M	ELECTRO 1.0UF 50WV	J	
C73			CE04KW1C470M	ELECTRO 47UF 16WV	J	
C74			CK73FB1H102K	CHIP C 1000PF	K	KK1M1
C74			CK73FB1H102K	CHIP C 1000PF	K	X1
C75			CC73FCH1H030C	CHIP C 3.0PF	C	
C76			CC73FCH1H470J	CHIP C 47PF	J	
C77			CC73FCH1H101J	CHIP C 100PF	J	M1
C78			CK73FB1H223K	CHIP C 0.022UF	K	
C79 ,80			CK73FB1H102K	CHIP C 1000PF	K	KK1
C79 ,80			CK73FB1H122K	CHIP C 1200PF	K	X1
C79 ,80			CK73FB1H152K	CHIP C 1500PF	K	M1
C79 ,80			CK73FB1H472K	CHIP C 4700PF	K	E1T1E2
C81			CK73FF1C105Z	CHIP C 1.0UF	Z	
C82			CK73FB1H103K	CHIP C 0.010UF	K	
C84 ,85			CK73FB1H332K	CHIP C 3300PF	K	
C88			CK73FB1H332K	CHIP C 3300PF	K	
C91			CK73FF1C105Z	CHIP C 1.0UF	Z	
C92 ,93			CK73FB1H102K	CHIP C 1000PF	K	KK1M1
C92 ,93			CK73FB1H102K	CHIP C 1000PF	K	X1
C94			CK73FB1H561K	CHIP C 560PF	K	
CN1			E40-3259-05	PIN ASSY		
CN2			E40-4871-05	PIN ASSY		
J1		*	E70-0141-05	LOCK TERMINAL BOARD		
CF1 ,2			L72-0531-05	CERAMIC FILTER		M1X1
CF1 ,2			L72-0536-05	CERAMIC FILTER		E1T1E2
CF1 ,2			L72-0596-05	CERAMIC FILTER		KK1
L1			L39-1384-05	COMBINATION COIL		
L2			L40-1091-82	SMALL FIXED INDUCTOR(1.0UH)		E1T1E2
L3			L30-0911-05	AM IFT		
L4			L30-0950-05	FM IFT		
L5			L30-0951-05	FM IFT		
L6 ,7			L79-1239-05	LC FILTER		E1T1E2
X1			L77-2187-05	CRYSTAL RESONATOR(7.2MHZ)		
R1			RK73FB2A101J	CHIP R 100	J	1/10W
R4			RK73FB2A681J	CHIP R 680	J	1/10W
R5			RK73FB2A332J	CHIP R 3.3K	J	1/10W
R6			RK73FB2A221J	CHIP R 220	J	1/10W
R7			RK73FB2A821J	CHIP R 820	J	1/10W
R8			RK73FB2A100J	CHIP R 10	J	1/10W
R8			RK73FB2A330J	CHIP R 33	J	1/10W
R8			RK73FB2A330J	CHIP R 33	J	1/10W
R9			RK73FB2A391J	CHIP R 390	J	1/10W
R10			RK73FB2A102J	CHIP R 1.0K	J	1/10W
R11			RK73FB2A220J	CHIP R 22	J	1/10W
R11			RK73FB2A330J	CHIP R 33	J	1/10W

L : Scandinavia K : USA P : Canada R : Mexico C : China I : Malaysia
 Y : PX(Far East,Hawaii) T : England E : Europe G : Germany V : China(Shanghai)
 Y : AAFES(Europe) X : Australia Q : Russia H : Korea M : Other Areas Δ indicates safety critical components .

* New Parts
 Parts without **Parts No.** are not supplied.
 Les articles non mentionnés dans le **Parts No.** ne sont pas fournis.
 Teile ohne **Parts No.** werden nicht geliefert.

8

Ref. No	Add-ress	New Parts	Parts No.	Description	Desti-nation	Re-marks
R11			RK73FB2A330J	CHIP R 33	J	1/10W
R12			RK73FB2A101J	CHIP R 100	J	1/10W
R14			RK73FB2A101J	CHIP R 100	J	1/10W
R15			RK73FB2A333J	CHIP R 33K	J	1/10W
R16			RK73FB2A220J	CHIP R 22	J	1/10W
R17			RK73FB2A362J	CHIP R 3.6K	J	1/10W
R18			RK73FB2A302J	CHIP R 3.0K	J	1/10W
R19			RK73FB2A822J	CHIP R 8.2K	J	1/10W
R20			RK73FB2A392J	CHIP R 3.9K	J	1/10W
R23			RK73FB2A153J	CHIP R 15K	J	1/10W
R23			RK73FB2A472J	CHIP R 4.7K	J	1/10W
R23			RK73FB2A682J	CHIP R 6.8K	J	1/10W
R25			RK73FB2A183J	CHIP R 18K	J	1/10W
R25			RK73FB2A183J	CHIP R 18K	J	1/10W
R25			RK73FB2A273J	CHIP R 27K	J	1/10W
R27 ,28			RK73FB2A432J	CHIP R 4.3K	J	1/10W
R27 ,28			RK73FB2A682J	CHIP R 6.8K	J	1/10W
R27 ,28			RK73FB2A682J	CHIP R 6.8K	J	1/10W
R29			RK73FB2A102J	CHIP R 1.0K	J	1/10W
R30			RK73FB2A561J	CHIP R 560	J	1/10W
R31			RK73FB2A473J	CHIP R 47K	J	1/10W
R33 ,34			RK73FB2A102J	CHIP R 1.0K	J	1/10W
R35			RK73FB2A101J	CHIP R 100	J	1/10W
R35			RK73FB2A101J	CHIP R 100	J	1/10W
R36			RK73FB2A102J	CHIP R 1.0K	J	1/10W
R36			RK73FB2A102J	CHIP R 1.0K	J	1/10W
R37			RK73FB2A392J	CHIP R 3.9K	J	1/10W
R37			RK73FB2A392J	CHIP R 3.9K	J	1/10W
R38			RK73FB2A102J	CHIP R 1.0K	J	1/10W
R38			RK73FB2A102J	CHIP R 1.0K	J	1/10W
R39			RK73FB2A103J	CHIP R 10K	J	1/10W
R39			RK73FB2A103J	CHIP R 10K	J	1/10W
R42			RK73FB2A103J	CHIP R 10K	J	1/10W
R43			RK73FB2A221J	CHIP R 220	J	1/10W
R44			RD14NB2E271J	RD 270	J	1/4W
R45			RK73EB2B332J	CHIP R 3.3K	J	1/8W
R46			RK73FB2A332J	CHIP R 3.3K	J	1/10W
R47			RK73EB2B332J	CHIP R 3.3K	J	1/8W
R48			RK73FB2A102J	CHIP R 1.0K	J	1/10W
R49			RK73FB2A103J	CHIP R 10K	J	1/10W
R50			RD14NB2E471J	RD 470	J	1/4W
R51			RK73FB2A562J	CHIP R 5.6K	J	1/10W
R52			RK73FB2A101J	CHIP R 100	J	1/10W
R53			RK73FB2A222J	CHIP R 2.2K	J	1/10W
R54			RK73FB2A102J	CHIP R 1.0K	J	1/10W
R55			RK73FB2A333J	CHIP R 33K	J	1/10W
R56 ,57			RK73FB2A102J	CHIP R 1.0K	J	1/10W
R58			RK73FB2A123J	CHIP R 12K	J	1/10W
R59			RK73FB2A122J	CHIP R 1.2K	J	1/10W
R72 ,73			RK73FB2A333J	CHIP R 33K	J	1/10W
R72 ,73			RK73FB2A333J	CHIP R 33K	J	1/10W
R72 ,73			RK73FB2A392J	CHIP R 3.9K	J	1/10W
R74			RK73FB2A473J	CHIP R 47K	J	1/10W
R75			RK73FB2A822J	CHIP R 8.2K	J	1/10W
R76			RK73FB2A182J	CHIP R 1.8K	J	1/10W

L : Scandinavia K : USA P : Canada R : Mexico C : China I : Malaysia
 Y : PX(Far East,Hawaii) T : England E : Europe G : Germany V : China(Shanghai)
 Y : AAFES(Europe) X : Australia Q : Russia H : Korea M : Other Areas Δ indicates safety critical components .

PARTS LIST

KRF-X9995D/X9995D-S/VR-5700/5900

* New Parts
Parts without **Parts No.** are not supplied.
Les articles non mentionnés dans le **Parts No.** ne sont pas fournis.
Teile ohne **Parts No.** werden nicht geliefert.



Ref. No	Add-ress	New Parts	Parts No.	Description	Desti-nation	Re-marks
R78			RK73FB2A821J	CHIP R 820 J 1/10W		
R79			RK73FB2A332J	CHIP R 3.3K J 1/10W		
R80			RK73FB2A223J	CHIP R 22K J 1/10W	E2	
R80			RK73FB2A223J	CHIP R 22K J 1/10W	K1E1T1	
R81			RS14KB3A151J	FL-PROOF RS 150 J 1W		
R82			RK73FB2A272J	CHIP R 2.7K J 1/10W		
R83			RK73FB2A102J	CHIP R 1.0K J 1/10W		
R84			RK73EB2B332J	CHIP R 3.3K J 1/8W		
R85 -87			RK73FB2A333J	CHIP R 33K J 1/10W		
R88			RK73FB2A563J	CHIP R 56K J 1/10W		
R89			RK73FB2A333J	CHIP R 33K J 1/10W		
R90			RK73FB2A681J	CHIP R 680 J 1/10W		
VR1			R32-0037-05	SEMI FIXED VARIABLE RESISTOR		
W51 ,52			R92-0670-05	CHIP R 0 OHM	M1	
W54 -56			R92-0670-05	CHIP R 0 OHM		
W54 ,55			R92-0670-05	CHIP R 0 OHM	KK1E1	
W54 ,55			R92-0670-05	CHIP R 0 OHM	X1T1E2	
W59 ,60			R92-0670-05	CHIP R 0 OHM		
W62			R92-0670-05	CHIP R 0 OHM		
W80			R92-0679-05	CHIP R 0 OHM		
W82 -85			R92-0679-05	CHIP R 0 OHM	KK1M1	
W82 -85			R92-0679-05	CHIP R 0 OHM	X1	
W84 ,85			R92-0679-05	CHIP R 0 OHM	E1T1E2	
S1			S62-0034-05	SLIDE SWITCH	M1	
D1			DA204U	DIODE		
D1			MA143A	DIODE		
D1			1SS302	DIODE		
D3			MTZJ8.2(B)	ZENER DIODE		
D3			RD8.2ES(B2)	ZENER DIODE		
D4			MTZJ5.1(B)	ZENER DIODE		
D4			RD5.1ES(B2)	ZENER DIODE		
D5			MTZJ2.7(B)	ZENER DIODE		
D5			RD2.7ES(B2)	ZENER DIODE		
D8			MA111	DIODE		
D9			MTZJ3.3(B)	ZENER DIODE		
D9			RD3.3ES(B2)	ZENER DIODE		
D11			MA111	DIODE	E2	
D11			MA111	DIODE	K1E1T1	
D13			MA111	DIODE		
IC1			LA1837	ANALOGUE IC		
IC2			LC72131	MOS-IC		
Q1			2SC4081(R,S)	TRANSISTOR		
Q1			2SC4116(Y,GR)	TRANSISTOR		
Q2			2SA1576A(R,S)	TRANSISTOR		
Q2			2SA1586(Y,GR)	TRANSISTOR		
Q3 ,4			2SC4081(R,S)	TRANSISTOR	M1	
Q3 ,4			2SC4116(Y,GR)	TRANSISTOR	M1	
Q6 ,7			2SC4081(R,S)	TRANSISTOR	E2	
Q6 ,7			2SC4081(R,S)	TRANSISTOR	K1E1T1	
Q6 ,7			2SC4116(Y,GR)	TRANSISTOR	E2	
Q6 ,7			2SC4116(Y,GR)	TRANSISTOR	K1E1T1	
Q10 ,11			2SD1757K	TRANSISTOR		
Q12			2SA1576A(R,S)	TRANSISTOR		
Q12			2SA1586(Y,GR)	TRANSISTOR		

L : Scandinavia K : USA P : Canada R : Mexico C : China I : Malaysia
Y : PX(Far East,Hawaii) T : England E : Europe G : Germany V : China(Shanghai)
Y : AAFES(Europe) X : Australia Q : Russia H : Korea M : Other Areas indicates safety critical components .

* New Parts
Parts without **Parts No.** are not supplied.
Les articles non mentionnés dans le **Parts No.** ne sont pas fournis.
Teile ohne **Parts No.** werden nicht geliefert.



Ref. No	Add-ress	New Parts	Parts No.	Description	Desti-nation	Re-marks
Q14			2SA1576A(R,S)	TRANSISTOR		
Q14			2SA1586(Y,GR)	TRANSISTOR		
A1			W02-2584-05	FM FRONT-END ASSY	E1T1E2	
A1			W02-2622-05	FM FRONT-END ASSY	KK1M1	
A1			W02-2622-05	FM FRONT-END ASSY	X1	
POWER AMP (X07-3350-11)						
C1 -4			CE04KW1H3R3M	ELECTRO 3.3UF	50WV	
C5 ,6			CC45FSL1H680J	CERAMIC 68PF	J	
C11 ,12			CK45FB1H222K	CERAMIC 2200PF	K	
C13 ,14			CC45FCH1H050C	CERAMIC 5.0PF	C	
C15 ,16			CC45FSL1H101J	CERAMIC 100PF	J	
C17 ,18			CE04KW1H100M	ELECTRO 10UF	50WV	
C19 ,20			CK45FF1H103Z	CERAMIC 0.010UF	Z	
C21 ,22			CC45FSL1H151J	CERAMIC 150PF	J	
C23 ,24			CC45FSL2H470J	CERAMIC 47PF	J	
C25 ,26			CC45FSL1H070D	CERAMIC 7.0PF	D	
C27 ,28			CE04KW1A221M	ELECTRO 220UF	10WV	
C51 -54			CE04KW1H3R3M	ELECTRO 3.3UF	50WV	
C55 ,56			CC45FSL1H680J	CERAMIC 68PF	J	
C61 ,62			CK45FB1H222K	CERAMIC 2200PF	K	
C63 ,64			CC45FCH1H050C	CERAMIC 5.0PF	C	
C65 ,66			CC45FSL1H101J	CERAMIC 100PF	J	
C67 ,68			CE04KW1H100M	ELECTRO 10UF	50WV	
C69 ,70			CK45FF1H103Z	CERAMIC 0.010UF	Z	
C71 ,72			CC45FSL1H151J	CERAMIC 150PF	J	
C73 ,74			CC45FSL2H470J	CERAMIC 47PF	J	
C75 ,76			CC45FSL1H070D	CERAMIC 7.0PF	D	
C77 ,78			CE04KW1A221M	ELECTRO 220UF	10WV	
C101,102			CE04KW1H3R3M	ELECTRO 3.3UF	50WV	
C103			CC45FSL1H680J	CERAMIC 68PF	J	
C106			CK45FB1H222K	CERAMIC 2200PF	K	
C107			CC45FCH1H050C	CERAMIC 5.0PF	C	
C108			CC45FSL1H101J	CERAMIC 100PF	J	
C109			CE04KW1A221M	ELECTRO 220UF	10WV	
C110			CK45FF1H103Z	CERAMIC 0.010UF	Z	
C111			CE04KW1H100M	ELECTRO 10UF	50WV	
C112			CC45FSL1H151J	CERAMIC 150PF	J	
C113			CC45FSL2H470J	CERAMIC 47PF	J	
C114			CC45FSL1H070D	CERAMIC 7.0PF	D	
C115			CE04KW1H220M	ELECTRO 22UF	50WV	
C116			CE04KW1E470M	ELECTRO 47UF	25WV	
C117			CE04KW1H220M	ELECTRO 22UF	50WV	
C118			CC45FSL1H101J	CERAMIC 100PF	J	
C119			CE04KW1E470M	ELECTRO 47UF	25WV	
C201-205			CK45FF1H103Z	CERAMIC 0.010UF	Z	
C251-254			CF92FV1H224J	MF-C 0.22UF	J	E1M1X1
C251-254			CF92FV1H224J	MF-C 0.22UF	J	T1E2
C255,256			CF92FV1H104J	MF-C 0.10UF	J	KK1
C257,258			CQ93FMG1H272J	MYLAR 2700PF	J	
C259-262			CF92FV1H224J	MF-C 0.22UF	J	E1M1X1
C259-262			CF92FV1H224J	MF-C 0.22UF	J	T1E2
C263,264			CF92FV1H104J	MF-C 0.10UF	J	KK1
C265,266			CQ93FMG1H393J	MYLAR 0.039UF	J	
C267,268			CK45FB1H102K	CERAMIC 1000PF	K	

L : Scandinavia K : USA P : Canada R : Mexico C : China I : Malaysia
Y : PX(Far East,Hawaii) T : England E : Europe G : Germany V : China(Shanghai)
Y : AAFES(Europe) X : Australia Q : Russia H : Korea M : Other Areas indicates safety critical components .

* New Parts

Parts without **Parts No.** are not supplied.

Les articles non mentionnés dans le **Parts No.** ne sont pas fournis.

Teile ohne **Parts No.** werden nicht geliefert.

11

Ref. No	Add-ress	New Parts	Parts No.	Description	Desti-nation	Re-marks
C269,270			CF92FV1H224J	MF-C 0.22UF	J	E1M1X1
C269,270			CF92FV1H224J	MF-C 0.22UF	J	T1E2
C271			CF92FV1H104J	MF-C 0.10UF	J	KK1
C301			CE04KW1A101M	ELECTRO 100UF	10WV	
C302			CE04KW1H4R7M	ELECTRO 4.7UF	50WV	
C303			CE04KW1H220M	ELECTRO 22UF	50WV	
C304			CE04KW1H470M	ELECTRO 47UF	50WV	
C305			CE04KW1E470M	ELECTRO 47UF	25WV	
C306,307			CE04KW2A100M	ELECTRO 10UF	100WV	
C308			CE04KW2A470M	ELECTRO 47UF	100WV	
C309,310			CE04KW2A100M	ELECTRO 10UF	100WV	
C351-354			CE04KW2A470M	ELECTRO 47UF	100WV	
C355,356			CE04KW1H470M	ELECTRO 47UF	50WV	
C401,402		*	C90-3951-05	ELECTRO 24000UF	75WV	
C403			C91-1422-05	MP	250WV	
C404			CK45FE2H103P	CERAMIC 0.010UF	P	KK1
C405,406			CK45FE2H103P	CERAMIC 0.010UF	P	
C451			CQ93FMG1H473J	MYLAR 0.047UF	J	
C452			CE04KW1E102M	ELECTRO 1000UF	25WV	
C453			C91-1488-05	MF 6800PF	250VAC	
C454		*	C91-1488-05	MF 6800PF	250VAC	M1
C455			C91-1627-05	POLYESTE 0.1UF	250VAC	
C456			CK45FF1H103Z	CERAMIC 0.010UF	Z	
C567-571			CC45FSL1H221J	CERAMIC 220PF	J	
CN1			E40-4879-05	PIN ASSY		
CN3			E40-8251-05	FLAT CABLE CONNECTOR		
CN4			E40-8255-05	FLAT CABLE CONNECTOR		
CN5			E40-4294-05	FLAT CABLE CONNECTOR		
CN6			E40-3247-05	PIN ASSY		
CN7			E40-3246-05	PIN ASSY		
CN8			E40-3247-05	PIN ASSY		
CN10			E40-4245-05	PIN ASSY		
CN11			E40-4245-05	PIN ASSY		KK1E1
CN11			E40-4245-05	PIN ASSY		X1T1E2
CN12		*	E40-4281-05	PIN ASSY		M1
J1			E70-0131-05	SCREW TERMINAL BOARD		
J2			E03-0148-05	AC OUTLET		KK1
J2			E03-0149-05	AC OUTLET		E1M1E2
J2			E03-0310-05	AC OUTLET		T1
J2			E03-0325-05	AC OUTLET		X1
F1			F05-5025-05	FUSE (SEMKO) (250V T5A L)		E1X1T1
F1			F05-5025-05	FUSE (SEMKO) (250V T5A L)		E2M1
F1			F51-0066-05	FUSE(6X30)		KK1
F2			F05-5025-05	FUSE (SEMKO) (250V T5A L)		M1
F3			F05-2525-05	FUSE (SEMKO) (250V T2.5AL)		E1E2
FAN	1B		F09-0139-05	FAN		
CN31,32			J13-0041-05	FUSE CLIP		KK1
CN31,32			J13-0075-05	FUSE CLIP		E1X1T1
CN31,32			J13-0075-05	FUSE CLIP		E2M1
CN33,34			J13-0075-05	FUSE CLIP		M1
CN35,36			J13-0075-05	FUSE CLIP		E1E2
E2			J11-0808-05	WIRE CLAMPER		

L : Scandinavia K : USA P : Canada R : Mexico C : China I : Malaysia

Y : PX(Far East,Hawaii) T : England E : Europe G : Germany V : China(Shanghai)

Y : AAFES(Europe) X : Australia Q : Russia H : Korea M : Other Areas Δ indicates safety critical components .

* New Parts

Parts without **Parts No.** are not supplied.

Les articles non mentionnés dans le **Parts No.** ne sont pas fournis.

Teile ohne **Parts No.** werden nicht geliefert.

12

Ref. No	Add-ress	New Parts	Parts No.	Description	Desti-nation	Re-marks
L1 -5			L39-0085-05	PHASE COMPENSATION COIL		
T1			L07-2936-05	POWER TRANSFORMER		E1X1T1
T1			L07-2936-05	POWER TRANSFORMER		E2
T1			L07-2937-05	POWER TRANSFORMER		M1
T1			L07-2939-05	POWER TRANSFORMER		KK1
R23 ,24			RD14NB2E101J	RD 100	J	1/4W
R29 -32			RD14NB2E221J	RD 220	J	1/4W
R73 ,74			RD14NB2E101J	RD 100	J	1/4W
R79 -82			RD14NB2E221J	RD 220	J	1/4W
R112			RD14NB2E101J	RD 100	J	1/4W
R115,116			RD14NB2E221J	RD 220	J	1/4W
R155			RD14NB2E220J	RD 22	J	1/4W
R201-204			RD14NB2E470J	RD 47	J	1/4W
R205,206			RD14NB2E151J	RD 150	J	1/4W
R207-210			RD14NB2E101J	RD 100	J	1/4W
R213-216			RD14NB2E332J	RD 3.3K	J	1/4W
R229,230			RD14NB2E220J	RD 22	J	1/4W
R251-254			RD14NB2E470J	RD 47	J	1/4W
R255,256			RD14NB2E151J	RD 150	J	1/4W
R257-260			RD14NB2E101J	RD 100	J	1/4W
R263-266			RD14NB2E332J	RD 3.3K	J	1/4W
R279,280			RD14NB2E220J	RD 22	J	1/4W
R301,302			RD14NB2E470J	RD 47	J	1/4W
R303			RD14NB2E151J	RD 150	J	1/4W
R304,305			RD14NB2E101J	RD 100	J	1/4W
R307,308			RD14NB2E332J	RD 3.3K	J	1/4W
R315			RD14NB2E220J	RD 22	J	1/4W
R351-355			RS14KB3D2R7J	FL-PROOF RS 2.7	J	2W
R356-359			RD14NB2E271J	RD 270	J	1/4W
R360,361			RS14KB3D471J	FL-PROOF RS 470	J	2W
R362			RD14NB2E271J	RD 270	J	1/4W
R394			RD14NB2E100J	RD 10	J	1/4W
R395			RD14NB2E682J	RD 6.8K	J	1/4W
R398			RD14NB2E272J	RD 2.7K	J	1/4W
R451,452			RD14NB2E1R0J	RD 1	J	1/4W
R453,454			RD14NB2E562J	RD 5.6K	J	1/4W
R455,456			RD14NB2E391J	RD 390	J	1/4W
R502			R92-1844-05	CARBON 3.3M	J	1/2W
R506			RD14NB2E1R0J	RD 1	J	1/4W
R510			RS14KB3D182J	FL-PROOF RS 1.8K	J	2W
VR1 -5			R32-0030-05	SEMI FIXED VARIABLE RESISTOR		
K1 -5			S76-0076-05	MAGNETIC RELAY		
K6			S76-0106-05	MAGNETIC RELAY		E1M1X1
K6			S76-0106-05	MAGNETIC RELAY		T1E2
K6		*	S76-0122-05	MAGNETIC RELAY		KK1
S1			S31-3010-05	SLIDE SWITCH		M1
D1 -4			HSS104A	DIODE		
D1 -4			1SS133	DIODE		
D11 -14			HSS104A	DIODE		
D11 -14			1SS133	DIODE		
D21 ,22			HSS104A	DIODE		
D21 ,22			1SS133	DIODE		
D51 ,52			1SS244	DIODE		
D53 -62			HSS104A	DIODE		

L : Scandinavia K : USA P : Canada R : Mexico C : China I : Malaysia

Y : PX(Far East,Hawaii) T : England E : Europe G : Germany V : China(Shanghai)

Y : AAFES(Europe) X : Australia Q : Russia H : Korea M : Other Areas Δ indicates safety critical components .

PARTS LIST

KRF-X9995D/X9995D-S/VR-5700/5900

* New Parts
Parts without **Parts No.** are not supplied.
Les articles non mentionnés dans le **Parts No.** ne sont pas fournis.
Teile ohne **Parts No.** werden nicht geliefert.

13

Ref. No	Add-ress	New Parts	Parts No.	Description	Desti-nation	Re-marks
D53 -62			1SS133	DIODE		
D71 ,72			1SS244	DIODE		
D73 -82			HSS104A	DIODE		
D73 -82			1SS133	DIODE		
D91			1SS244	DIODE		
D92 -96			HSS104A	DIODE		
D92 -96			1SS133	DIODE		
△ D100		*	RBV-2506LFA	DIODE		
△ D101,102			S5688B	DIODE		
D103			MTZJ13(B)	ZENER DIODE		
D103			RD13ES(B2)	ZENER DIODE		
D104			MTZJ15(B)	ZENER DIODE		
D104			RD15ES(B2)	ZENER DIODE		
D105,106			MTZJ4.7(B)	ZENER DIODE		
D105,106			RD4.7ES(B2)	ZENER DIODE		
D107,108			HSS104A	DIODE		
D107,108			1SS133	DIODE		
D109			MTZJ5.1(B)	ZENER DIODE		
D109			RD5.1ES(B2)	ZENER DIODE		
D111-115			HSS104A	DIODE		
D111-115			1SS133	DIODE		
D121,122			MTZJ18(B)	ZENER DIODE		
D121,122			RD18ES(B2)	ZENER DIODE		
D123,124			MTZJ20(B)	ZENER DIODE		
D123,124			RD20ES(B2)	ZENER DIODE		
D201-204			MTZJ6.2(B)	ZENER DIODE		
D201-204			RD6.2ES(B2)	ZENER DIODE		
D205,206			HSS104A	DIODE		
D205,206			1SS133	DIODE		
D207,208			MTZJ24(B)	ZENER DIODE		
D207,208			RD24ES(B2)	ZENER DIODE		
D209,210			MTZJ10(B)	ZENER DIODE		
D209,210			RD10ES(B2)	ZENER DIODE		
D211,212			MTZJ13(B)	ZENER DIODE		
D211,212			RD13ES(B2)	ZENER DIODE		
D213-216			HSS104A	DIODE		
D213-216			1SS133	DIODE		
D217			MTZJ2.7(B)	ZENER DIODE		
D217			RD2.7ES(B2)	ZENER DIODE		
D251			MTZJ5.1(B)	ZENER DIODE		
D251			RD5.1ES(B2)	ZENER DIODE		
D252,253			HSS104A	DIODE		
D252,253			1SS133	DIODE		
D502			HSS104A	DIODE		
D502			1SS133	DIODE		
△ D503-508			S5688B	DIODE		
△ D509			HSS104A	DIODE		
△ D509			1SS133	DIODE		
△ D510			S5688B	DIODE		
△ D511-513			HSS104A	DIODE		
D511-513			1SS133	DIODE		
D514			MTZJ4.7(B)	ZENER DIODE		
D514			RD4.7ES(B2)	ZENER DIODE		
Q1 ,2			2SC2878(B)	TRANSISTOR		
Q3 -6			2SA992(F,E)	TRANSISTOR		

L : Scandinavia K : USA P : Canada R : Mexico C : China I : Malaysia
Y : PX(Far East,Hawaii) T : England E : Europe G : Germany V : China(Shanghai)
Y : AAFES(Europe) X : Australia Q : Russia H : Korea M : Other Areas △ indicates safety critical components .

* New Parts
Parts without **Parts No.** are not supplied.
Les articles non mentionnés dans le **Parts No.** ne sont pas fournis.
Teile ohne **Parts No.** werden nicht geliefert.

14

Ref. No	Add-ress	New Parts	Parts No.	Description	Desti-nation	Re-marks
Q7 ,8			2SA1123(R,S)	TRANSISTOR		
Q9 -12			2SC2631(R,S)	TRANSISTOR		
Q13 ,14			2SA1048(Y,GR)	TRANSISTOR		
Q13 ,14			2SA933AS(Q,R)	TRANSISTOR		
Q51 ,52			2SC2878(B)	TRANSISTOR		
Q53 -56			2SA992(F,E)	TRANSISTOR		
Q57 ,58			2SA1123(R,S)	TRANSISTOR		
Q59 -62			2SC2631(R,S)	TRANSISTOR		
Q63 ,64			2SA1048(Y,GR)	TRANSISTOR		
Q63 ,64			2SA933AS(Q,R)	TRANSISTOR		
Q101			2SC2878(B)	TRANSISTOR		
Q102,103			2SA992(F,E)	TRANSISTOR		
Q104,105			2SC2631(R,S)	TRANSISTOR		
Q106			2SA1123(R,S)	TRANSISTOR		
Q107			2SA1048(Y,GR)	TRANSISTOR		
Q107			2SA933AS(Q,R)	TRANSISTOR		
△ Q108			2SC1740S(Q,R)	TRANSISTOR		
△ Q108			2SC2458(Y,GR)	TRANSISTOR		
Q109			DTC124ESA	DIGITAL TRANSISTOR		
Q109			UN4212	DIGITAL TRANSISTOR		
△ Q201,202		*	TRAIT7N*5	TRANSISTOR		
△ Q203,204		*	TRAIT7P*5	TRANSISTOR		
Q205,206			2SC1845(F,E)	TRANSISTOR		
Q207,208			2SA992(F,E)	TRANSISTOR		
△ Q251,252		*	TRAIT7N*5	TRANSISTOR		
△ Q253,254		*	TRAIT7P*5	TRANSISTOR		
Q255,256			2SC1845(F,E)	TRANSISTOR		
Q257,258			2SA992(F,E)	TRANSISTOR		
△ Q301		*	TRAIT7N*5	TRANSISTOR		
△ Q302		*	TRAIT7P*5	TRANSISTOR		
Q303			2SC1845(F,E)	TRANSISTOR		
Q304			2SA992(F,E)	TRANSISTOR		
Q351-354			DTC113ZSA	DIGITAL TRANSISTOR		
Q351-354			UN4219	DIGITAL TRANSISTOR		
Q381,382			2SC1845(F,E)	TRANSISTOR		
Q383,384			2SA992(F,E)	TRANSISTOR		
Q401			DTC124ESA	DIGITAL TRANSISTOR		
Q401			UN4212	DIGITAL TRANSISTOR		
Q402,403			DTC113ZSA	DIGITAL TRANSISTOR		
Q402,403			UN4219	DIGITAL TRANSISTOR		
△ Q404			2SD2012	TRANSISTOR		
Q405,406			2SC1740S(Q,R)	TRANSISTOR		
Q405,406			2SC2458(Y,GR)	TRANSISTOR		
△ Q407			2SA1110(R,S)	TRANSISTOR		
Q408			2SC2003(L,K)	TRANSISTOR		
△ Q421			2SC3944A	TRANSISTOR		
△ Q422			2SA1535A	TRANSISTOR		
Q423			2SC1740S(Q,R)	TRANSISTOR		
Q423			2SC2458(Y,GR)	TRANSISTOR		
Q424			2SA1048(Y,GR)	TRANSISTOR		
Q424			2SA933AS(Q,R)	TRANSISTOR		
Q425			2SC1740S(Q,R)	TRANSISTOR		
Q425			2SC2458(Y,GR)	TRANSISTOR		
Q426			2SA1048(Y,GR)	TRANSISTOR		
Q426			2SA933AS(Q,R)	TRANSISTOR		

L : Scandinavia K : USA P : Canada R : Mexico C : China I : Malaysia
Y : PX(Far East,Hawaii) T : England E : Europe G : Germany V : China(Shanghai)
Y : AAFES(Europe) X : Australia Q : Russia H : Korea M : Other Areas △ indicates safety critical components .

* New Parts
Parts without **Parts No.** are not supplied.
Les articles non mentionnés dans le **Parts No.** ne sont pas fournis.
Teile ohne **Parts No.** werden nicht geliefert.

15

Ref. No	Add-ress	New Parts	Parts No.	Description	Desti-nation	Re-marks
Q427			DTC124ESA	DIGITAL TRANSISTOR		
Q428			UN4212	DIGITAL TRANSISTOR		
Q429			DTA143TSA	DIGITAL TRANSISTOR		
Q530			UN4116	DIGITAL TRANSISTOR		
Q530			2SA992(F,E)	TRANSISTOR		
Q530			2SA1048(Y,GR)	TRANSISTOR		
Q530			2SA933AS(Q,R)	TRANSISTOR		
SURROUND (X08-3090-11)						
C1			CC73GCH1H470J	CHIP C	47PF	J
C2			CK73GB1H103K	CHIP C	0.010UF	K
C4			CC73GCH1H470J	CHIP C	47PF	J
C11			CC73GCH1H470J	CHIP C	47PF	J
C12			CK73GB1H103K	CHIP C	0.010UF	K
C14			CC73GCH1H470J	CHIP C	47PF	J
C15			CC73GCH1H102J	CHIP C	1000PF	J
C21			CC73GCH1H470J	CHIP C	47PF	J
C22			CK73GB1H103K	CHIP C	0.010UF	K
C24			CC73GCH1H470J	CHIP C	47PF	J
C31			CC73GCH1H470J	CHIP C	47PF	J
C32			CK73GB1H103K	CHIP C	0.010UF	K
C34			CC73GCH1H470J	CHIP C	47PF	J
C35			CC73GCH1H102J	CHIP C	1000PF	J
C41			CC73GCH1H470J	CHIP C	47PF	J
C42			CK73GB1H103K	CHIP C	0.010UF	K
C44			CC73GCH1H470J	CHIP C	47PF	J
C51			CC73GCH1H470J	CHIP C	47PF	J
C52			CK73GB1H103K	CHIP C	0.010UF	K
C54			CC73GCH1H470J	CHIP C	47PF	J
C55			CC73GCH1H102J	CHIP C	1000PF	J
C61			CC73GCH1H470J	CHIP C	47PF	J
C62			CK73GB1H103K	CHIP C	0.010UF	K
C64			CC73GCH1H470J	CHIP C	47PF	J
C71			CC73GCH1H102J	CHIP C	1000PF	J
C72			CC73GCH1H220J	CHIP C	22PF	J
C73			CK73GF1E104Z	CHIP C	0.10UF	Z
C74			CC73GCH1H220J	CHIP C	22PF	J
C75			CC73GCH1H102J	CHIP C	1000PF	J
C76			CC73GCH1H270J	CHIP C	27PF	J
C101			CK73GF1E104Z	CHIP C	0.10UF	Z
C102			CC73GCH1H102J	CHIP C	1000PF	J
C103, 104			CC73GCH1H220J	CHIP C	22PF	J
C105			CK73GF1E104Z	CHIP C	0.10UF	Z
C107-109			CK73GF1E104Z	CHIP C	0.10UF	Z
C110			CK73GB1H103K	CHIP C	0.010UF	K
C111			CE04KW1H100M	ELECTRO	10UF	50WV
C112			CC73GCH1H470J	CHIP C	47PF	J
C113			CC73GCH1H150J	CHIP C	15PF	J
C114			CC73GCH1H470J	CHIP C	47PF	J
C116			CE04KW1A101M	ELECTRO	100UF	10WV
C201			CE04KW1H100M	ELECTRO	10UF	50WV
C202			CC73GCH1H102J	CHIP C	1000PF	J
C203			CE04KW1A101M	ELECTRO	100UF	10WV
C205			CE04KW1E470M	ELECTRO	47UF	25WV
C206			CC73GCH1H102J	CHIP C	1000PF	J

L : Scandinavia K : USA P : Canada R : Mexico C : China I : Malaysia
Y : PX(Far East,Hawaii) T : England E : Europe G : Germany V : China(Shanghai)
Y : AAFES(Europe) X : Australia Q : Russia H : Korea M : Other Areas Δ indicates safety critical components .

* New Parts
Parts without **Parts No.** are not supplied.
Les articles non mentionnés dans le **Parts No.** ne sont pas fournis.
Teile ohne **Parts No.** werden nicht geliefert.

16

Ref. No	Add-ress	New Parts	Parts No.	Description	Desti-nation	Re-marks
C207			CE04KW1H100M	ELECTRO	10UF	50WV
C208			CE04KW1E470M	ELECTRO	47UF	25WV
C212			CC73GCH1H470J	CHIP C	47PF	J
C213-216			CC73GCH1H471J	CHIP C	470PF	J
C221,222			CE04KW1H100M	ELECTRO	10UF	50WV
C223,224			CC73GCH1H101J	CHIP C	100PF	J
C225,226			CC73GCH1H151J	CHIP C	150PF	J
C227,228			CC73GCH1H101J	CHIP C	100PF	J
C229,230			CE04KW1E470M	ELECTRO	47UF	25WV
C231,232			CC73GCH1H220J	CHIP C	22PF	J
C233,234			CK73GB1H222K	CHIP C	2200PF	K
C235,236			CC73GCH1H101J	CHIP C	100PF	J
C301			CK73GF1E104Z	CHIP C	0.10UF	Z
C302			CE04KW1A101M	ELECTRO	100UF	10WV
C303			CC73GCH1H102J	CHIP C	1000PF	J
C304			CE04KW1H100M	ELECTRO	10UF	50WV
C305			CC73GCH1H101J	CHIP C	100PF	J
C306			CE04KW1H100M	ELECTRO	10UF	50WV
C307			CC73GCH1H101J	CHIP C	100PF	J
C311,312			CQ93FMG1H272J	MYLAR	2700PF	J
C313,314			CC73GCH1H220J	CHIP C	22PF	J
C315-320			CC73GCH1H101J	CHIP C	100PF	J
C321,322			CQ93FMG1H223J	MYLAR	0.022UF	J
C323,324			CC73GCH1H101J	CHIP C	100PF	J
C325,326			CQ93FMG1H102J	MYLAR	1000PF	J
C327,328			CQ93FMG1H472J	MYLAR	4700PF	J
C329,330			CC73GCH1H101J	CHIP C	100PF	J
C331,332			CC73GCH1H050C	CHIP C	5.0PF	C
C351			CK73GF1E104Z	CHIP C	0.10UF	Z
C352			CE04KW1A101M	ELECTRO	100UF	10WV
C353			CC73GCH1H102J	CHIP C	1000PF	J
C354			CE04KW1H100M	ELECTRO	10UF	50WV
C355			CC73GCH1H101J	CHIP C	100PF	J
C356			CE04KW1H100M	ELECTRO	10UF	50WV
C357			CC73GCH1H101J	CHIP C	100PF	J
C361,362			CQ93FMG1H272J	MYLAR	2700PF	J
C363,364			CC73GCH1H220J	CHIP C	22PF	J
C365-370			CC73GCH1H101J	CHIP C	100PF	J
C371,372			CQ93FMG1H223J	MYLAR	0.022UF	J
C373,374			CC73GCH1H101J	CHIP C	100PF	J
C375,376			CQ93FMG1H102J	MYLAR	1000PF	J
C377,378			CQ93FMG1H472J	MYLAR	4700PF	J
C379,380			CC73GCH1H101J	CHIP C	100PF	J
C381,382			CC73GCH1H050C	CHIP C	5.0PF	C
C401			CK73GF1E104Z	CHIP C	0.10UF	Z
C402			CE04KW1A101M	ELECTRO	100UF	10WV
C403			CC73GCH1H102J	CHIP C	1000PF	J
C404			CE04KW1H100M	ELECTRO	10UF	50WV
C405			CC73GCH1H101J	CHIP C	100PF	J
C406			CE04KW1H100M	ELECTRO	10UF	50WV
C407			CC73GCH1H101J	CHIP C	100PF	J
C411			CQ93FMG1H272J	MYLAR	2700PF	J
C412			CQ93FMG1H103J	MYLAR	0.010UF	J
C413,414			CC73GCH1H220J	CHIP C	22PF	J
C415-417			CC73GCH1H101J	CHIP C	100PF	J

L : Scandinavia K : USA P : Canada R : Mexico C : China I : Malaysia
Y : PX(Far East,Hawaii) T : England E : Europe G : Germany V : China(Shanghai)
Y : AAFES(Europe) X : Australia Q : Russia H : Korea M : Other Areas Δ indicates safety critical components .

PARTS LIST

KRF-X9995D/X9995D-S/VR-5700/5900

* New Parts
Parts without **Parts No.** are not supplied.
Les articles non mentionnés dans le **Parts No.** ne sont pas fournis.
Teile ohne **Parts No.** werden nicht geliefert.



Ref. No	Add-ress	New Parts	Parts No.	Description	Desti-nation	Re-marks
C418			CK73GB1H272K	CHIP C 2700PF	K	
C419,420			CC73GCH1H101J	CHIP C 100PF	J	
C421,422			CQ93FMG1H223J	MYLAR 0.022UF	J	
C423,424			CC73GCH1H101J	CHIP C 100PF	J	
C425			CQ93FMG1H102J	MYLAR 1000PF	J	
C426			CQ93FMG1H272J	MYLAR 2700PF	J	
C427			CQ93FMG1H472J	MYLAR 4700PF	J	
C428			CQ93FMG1H223J	MYLAR 0.022UF	J	
C429,430			CC73GCH1H101J	CHIP C 100PF	J	
C431,432			CC73GCH1H050C	CHIP C 5.0PF	C	
C451			CK73GF1E104Z	CHIP C 0.10UF	Z	
C452			CE04KW1A101M	ELECTRO 100UF	10WV	
C453			CC73GCH1H102J	CHIP C 1000PF	J	
C454			CE04KW1H100M	ELECTRO 10UF	50WV	
C455			CC73GCH1H101J	CHIP C 100PF	J	
C456			CE04KW1H100M	ELECTRO 10UF	50WV	
C457			CC73GCH1H101J	CHIP C 100PF	J	
C461,462			CQ93FMG1H272J	MYLAR 2700PF	J	
C463,464			CC73GCH1H220J	CHIP C 22PF	J	
C465-470			CC73GCH1H101J	CHIP C 100PF	J	
C471,472			CQ93FMG1H223J	MYLAR 0.022UF	J	
C473,474			CC73GCH1H101J	CHIP C 100PF	J	
C475,476			CQ93FMG1H102J	MYLAR 1000PF	J	
C477,478			CQ93FMG1H472J	MYLAR 4700PF	J	
C479,480			CC73GCH1H101J	CHIP C 100PF	J	
C481,482			CC73GCH1H050C	CHIP C 5.0PF	C	
C601-605			CC73GCH1H102J	CHIP C 1000PF	J	
C606,607			CC73GCH1H090D	CHIP C 9.0PF	D	
C608-630			CC73GCH1H102J	CHIP C 1000PF	J	
C631			CK73GB1H103K	CHIP C 0.010UF	K	
C632-634			CC73GCH1H102J	CHIP C 1000PF	J	
C701-706			CC73GCH1H102J	CHIP C 1000PF	J	
C707			CK73GB1H103K	CHIP C 0.010UF	K	
C801,802			CK73GB1H103K	CHIP C 0.010UF	K	
C803			CE04KW1H100M	ELECTRO 10UF	50WV	
C804			CK73GB1H103K	CHIP C 0.010UF	K	
C805			CC73GCH1H102J	CHIP C 1000PF	J	
C806			CK73GB1H103K	CHIP C 0.010UF	K	
C951			CE04KW1E470M	ELECTRO 47UF	25WV	
C954			CE04KW1E470M	ELECTRO 47UF	25WV	
C955			CE04DW1A102M	ELECTRO 1000UF	10WV	
C956			CK73GB1H103K	CHIP C 0.010UF	K	
C958			CE04KW1A101M	ELECTRO 100UF	10WV	
C959			CE04KW1H100M	ELECTRO 10UF	50WV	
C960			CC73GCH1H102J	CHIP C 1000PF	J	
C961			CK73GB1H103K	CHIP C 0.010UF	K	
C963			CE04KW1A101M	ELECTRO 100UF	10WV	
C965			CE04KW1E470M	ELECTRO 47UF	25WV	
CN1 ,2			E40-9836-05	SOCKET FOR PIN ASSY		
CN3			E40-9832-05	SOCKET FOR PIN ASSY		
J1			E63-1128-05	PIN JACK		
J2			E63-1130-05	PIN JACK		
J3 ,4			E63-1124-05	PIN JACK		
Δ L1 ,2			L40-4795-34	SMALL FIXED INDUCTOR(4.7UH)		

L : Scandinavia K : USA P : Canada R : Mexico C : China I : Malaysia
Y : PX(Far East,Hawaii) T : England E : Europe G : Germany V : China(Shanghai)
Y : AAFES(Europe) X : Australia Q : Russia H : Korea M : Other Areas Δ indicates safety critical components .

* New Parts
Parts without **Parts No.** are not supplied.
Les articles non mentionnés dans le **Parts No.** ne sont pas fournis.
Teile ohne **Parts No.** werden nicht geliefert.



Ref. No	Add-ress	New Parts	Parts No.	Description	Desti-nation	Re-marks
X1		*	L77-2337-05	CRYSTAL RESONATOR(12.288MHZ)		
X2		*	L77-2314-05	CRYSTAL RESONATOR(33MHZ)		
X3			L78-0604-05	RESONATOR (6.00MHZ)		
R1			RK73GB1J750J	CHIP R 75	J	1/16W
R2			RK73GB1J751J	CHIP R 750	J	1/16W
R3			RK73GB1J104J	CHIP R 100K	J	1/16W
R4			RK73GB1J184J	CHIP R 180K	J	1/16W
R5			RK73GB1J470J	CHIP R 47	J	1/16W
R7			RK73GB1J151J	CHIP R 150	J	1/16W
R11			RK73GB1J750J	CHIP R 75	J	1/16W
R12			RK73GB1J751J	CHIP R 750	J	1/16W
R13			RK73GB1J104J	CHIP R 100K	J	1/16W
R14			RK73GB1J184J	CHIP R 180K	J	1/16W
R15			RK73GB1J470J	CHIP R 47	J	1/16W
R17			RK73GB1J151J	CHIP R 150	J	1/16W
Δ R18			RK73FB2A100J	CHIP R 10	J	1/10W
R21			RK73GB1J750J	CHIP R 75	J	1/16W
R22			RK73GB1J751J	CHIP R 750	J	1/16W
R23			RK73GB1J104J	CHIP R 100K	J	1/16W
R24			RK73GB1J184J	CHIP R 180K	J	1/16W
R25			RK73GB1J470J	CHIP R 47	J	1/16W
R27			RK73GB1J151J	CHIP R 150	J	1/16W
R31			RK73GB1J750J	CHIP R 75	J	1/16W
R32			RK73GB1J751J	CHIP R 750	J	1/16W
R33			RK73GB1J104J	CHIP R 100K	J	1/16W
R34			RK73GB1J184J	CHIP R 180K	J	1/16W
R35			RK73GB1J470J	CHIP R 47	J	1/16W
R37			RK73GB1J151J	CHIP R 150	J	1/16W
R41			RK73GB1J750J	CHIP R 75	J	1/16W
R42			RK73GB1J751J	CHIP R 750	J	1/16W
R43			RK73GB1J104J	CHIP R 100K	J	1/16W
R44			RK73GB1J184J	CHIP R 180K	J	1/16W
R45			RK73GB1J470J	CHIP R 47	J	1/16W
Δ R47			RK73GB1J151J	CHIP R 150	J	1/16W
R48			RK73FB2A100J	CHIP R 10	J	1/10W
R51			RK73GB1J750J	CHIP R 75	J	1/16W
R52			RK73GB1J751J	CHIP R 750	J	1/16W
R53			RK73GB1J104J	CHIP R 100K	J	1/16W
R54			RK73GB1J184J	CHIP R 180K	J	1/16W
R55			RK73GB1J470J	CHIP R 47	J	1/16W
R57			RK73GB1J151J	CHIP R 150	J	1/16W
Δ R58			RK73FB2A100J	CHIP R 10	J	1/10W
R61			RK73GB1J750J	CHIP R 75	J	1/16W
R62			RK73GB1J751J	CHIP R 750	J	1/16W
R63			RK73GB1J104J	CHIP R 100K	J	1/16W
R64			RK73GB1J184J	CHIP R 180K	J	1/16W
R65			RK73GB1J470J	CHIP R 47	J	1/16W
R67			RK73GB1J151J	CHIP R 150	J	1/16W
Δ R71			RK73FB2A100J	CHIP R 10	J	1/10W
R72			RK73GB1J100J	CHIP R 10	J	1/16W
R73			RK73GB1J221J	CHIP R 220	J	1/16W
R74 ,75			RK73GB1J750J	CHIP R 75	J	1/16W
Δ R76			RK73FB2A100J	CHIP R 10	J	1/10W
R77			RK73GB1J101J	CHIP R 100	J	1/16W

L : Scandinavia K : USA P : Canada R : Mexico C : China I : Malaysia
Y : PX(Far East,Hawaii) T : England E : Europe G : Germany V : China(Shanghai)
Y : AAFES(Europe) X : Australia Q : Russia H : Korea M : Other Areas Δ indicates safety critical components .

* New Parts
Parts without **Parts No.** are not supplied.
Les articles non mentionnés dans le **Parts No.** ne sont pas fournis.
Teile ohne **Parts No.** werden nicht geliefert.

19

Ref. No	Add-ress	New Parts	Parts No.	Description	Desti-nation	Re-marks
R79			RK73GB1J102J	CHIP R 1.0K J 1/16W		
R80			RK73GB1J103J	CHIP R 10K J 1/16W		
Δ R101			RK73FB2A100J	CHIP R 10 J 1/10W		
R102			RK73GB1J101J	CHIP R 100 J 1/16W		
R103,104			RK73GB1J105J	CHIP R 1.0M J 1/16W		
R105			RK73GB1J152J	CHIP R 1.5K J 1/16W		
R106			RK73GB1J102J	CHIP R 1.0K J 1/16W		
R107			RK73GB1J183J	CHIP R 18K J 1/16W		
R108			RK73FB2A1R0J	CHIP R 1 J 1/10W		
R110			RK73GB1J103J	CHIP R 10K J 1/16W		
R111			RK73GB1J102J	CHIP R 1.0K J 1/16W		
R112			RK73GB1J103J	CHIP R 10K J 1/16W		
R113-117			RK73GB1J102J	CHIP R 1.0K J 1/16W		
R118			RK73GB1J471J	CHIP R 470 J 1/16W		
R119			RK73GB1J472J	CHIP R 4.7K J 1/16W		
R120			RK73GB1J103J	CHIP R 10K J 1/16W		
R121			RK73GB1J102J	CHIP R 1.0K J 1/16W		
R122			RK73GB1J151J	CHIP R 150 J 1/16W		
R123			RK73GB1J101J	CHIP R 100 J 1/16W		
R124			RK73GB1J151J	CHIP R 150 J 1/16W		
R125			RK73GB1J101J	CHIP R 100 J 1/16W		
R126			RK73FB2A2R2J	CHIP R 2.2 J 1/10W		
R127			RK73GB1J103J	CHIP R 10K J 1/16W		
R201			RK73FB2A1R0J	CHIP R 1 J 1/10W		
R202			RK73GB1J102J	CHIP R 1.0K J 1/16W		
R203-206			RK73GB1J473J	CHIP R 47K J 1/16W		
R207			RK73FB2A1R0J	CHIP R 1 J 1/10W		
R208,209			RK73GB1J103J	CHIP R 10K J 1/16W		
R210			RK73GB1J101J	CHIP R 100 J 1/16W		
R211			RK73GB1J221J	CHIP R 220 J 1/16W		
R221,222			RK73GB1J273J	CHIP R 27K J 1/16W		
R223,224			RK73GB1J123J	CHIP R 12K J 1/16W		
R225,226			RK73GB1J561J	CHIP R 560 J 1/16W		
R227-230			RK73GB1J472J	CHIP R 4.7K J 1/16W		
R233-236			RK73GB1J471J	CHIP R 470 J 1/16W		
Δ R301			RK73FB2A100J	CHIP R 10 J 1/10W		
R302-304			RK73GB1J102J	CHIP R 1.0K J 1/16W		
R305			RK73FB2A100J	CHIP R 10 J 1/10W		
Δ R306			RK73FB2A1R0J	CHIP R 1 J 1/10W		
R307			RK73GB1J1R0J	CHIP R 1 J 1/16W		
R311-314			RK73GB1J182J	CHIP R 1.8K J 1/16W		
R315-318			RK73GB1J102J	CHIP R 1.0K J 1/16W		
R319-322			RK73GB1J472J	CHIP R 4.7K J 1/16W		
R323,324			RK73GB1J100J	CHIP R 10 J 1/16W		
R325-328			RK73GB1J681J	CHIP R 680 J 1/16W		
R329,330			RK73GB1J471J	CHIP R 470 J 1/16W		
R331,332			RK73GB1J121J	CHIP R 120 J 1/16W		
R333,334			RK73GB1J100J	CHIP R 10 J 1/16W		
R335,336			RK73GB1J1R0J	CHIP R 1 J 1/16W		
Δ R351			RK73FB2A100J	CHIP R 10 J 1/10W		
R352-354			RK73GB1J102J	CHIP R 1.0K J 1/16W		
R355			RK73FB2A100J	CHIP R 10 J 1/10W		
R356			RK73FB2A1R0J	CHIP R 1 J 1/10W		
R357			RK73GB1J1R0J	CHIP R 1 J 1/16W		
R361-368			RK73GB1J102J	CHIP R 1.0K J 1/16W		

L : Scandinavia K : USA P : Canada R : Mexico C : China I : Malaysia
Y : PX(Far East,Hawaii) T : England E : Europe G : Germany V : China(Shanghai)
Y : AAFES(Europe) X : Australia Q : Russia H : Korea M : Other Areas Δ indicates safety critical components .

* New Parts
Parts without **Parts No.** are not supplied.
Les articles non mentionnés dans le **Parts No.** ne sont pas fournis.
Teile ohne **Parts No.** werden nicht geliefert.

20

Ref. No	Add-ress	New Parts	Parts No.	Description	Desti-nation	Re-marks
R369-372			RK73GB1J472J	CHIP R 4.7K J 1/16W		
R373,374			RK73GB1J100J	CHIP R 10 J 1/16W		
R375-378			RK73GB1J511J	CHIP R 510 J 1/16W		
R379,380			RK73GB1J471J	CHIP R 470 J 1/16W		
R381,382			RK73GB1J121J	CHIP R 120 J 1/16W		
R383,384			RK73GB1J100J	CHIP R 10 J 1/16W		
R385,386			RK73GB1J1R0J	CHIP R 1 J 1/16W		
Δ R401			RK73FB2A100J	CHIP R 10 J 1/10W		
R402-404			RK73GB1J102J	CHIP R 1.0K J 1/16W		
R405			RK73FB2A100J	CHIP R 10 J 1/10W		
Δ R406			RK73FB2A1R0J	CHIP R 1 J 1/10W		
R407			RK73GB1J1R0J	CHIP R 1 J 1/16W		
R411,412			RK73GB1J182J	CHIP R 1.8K J 1/16W		
R413,414			RK73GB1J242J	CHIP R 2.4K J 1/16W		
R415,416			RK73GB1J102J	CHIP R 1.0K J 1/16W		
R417,418			RK73GB1J122J	CHIP R 1.2K J 1/16W		
R419			RK73GB1J472J	CHIP R 4.7K J 1/16W		
R420			RK73GB1J273J	CHIP R 27K J 1/16W		
R421			RK73GB1J472J	CHIP R 4.7K J 1/16W		
R422			RK73GB1J273J	CHIP R 27K J 1/16W		
R423,424			RK73GB1J100J	CHIP R 10 J 1/16W		
R425			RK73GB1J681J	CHIP R 680 J 1/16W		
R426			RK73GB1J123J	CHIP R 12K J 1/16W		
R427			RK73GB1J681J	CHIP R 680 J 1/16W		
R428			RK73GB1J123J	CHIP R 12K J 1/16W		
R429			RK73GB1J471J	CHIP R 470 J 1/16W		
R430			RK73GB1J183J	CHIP R 18K J 1/16W		
R431			RK73GB1J121J	CHIP R 120 J 1/16W		
R432			RK73GB1J152J	CHIP R 1.5K J 1/16W		
R433,434			RK73GB1J100J	CHIP R 10 J 1/16W		
Δ R435,436			RK73GB1J1R0J	CHIP R 1 J 1/16W		
R451			RK73FB2A100J	CHIP R 10 J 1/10W		
R452-454			RK73GB1J102J	CHIP R 1.0K J 1/16W		
R455			RK73FB2A100J	CHIP R 10 J 1/10W		
Δ R456			RK73FB2A1R0J	CHIP R 1 J 1/10W		
R457			RK73GB1J1R0J	CHIP R 1 J 1/16W		
R461-468			RK73GB1J102J	CHIP R 1.0K J 1/16W		
R469-472			RK73GB1J472J	CHIP R 4.7K J 1/16W		
R473,474			RK73GB1J100J	CHIP R 10 J 1/16W		
R475-478			RK73GB1J511J	CHIP R 510 J 1/16W		
R479,480			RK73GB1J471J	CHIP R 470 J 1/16W		
R481,482			RK73GB1J121J	CHIP R 120 J 1/16W		
R483,484			RK73GB1J100J	CHIP R 10 J 1/16W		
R485,486			RK73GB1J1R0J	CHIP R 1 J 1/16W		
R550			RK73GB1J101J	CHIP R 100 J 1/16W		
R601			RK73FB2A1R0J	CHIP R 1 J 1/10W		
R602-605			RK73GB1J103J	CHIP R 10K J 1/16W		
R606,607			RK73GB1J470J	CHIP R 47 J 1/16W		
R608			RK73GB1J103J	CHIP R 10K J 1/16W		
R609			RK73FB2A1R0J	CHIP R 1 J 1/10W		
R610,611			RK73GB1J470J	CHIP R 47 J 1/16W		
R612-615			RK73GB1J103J	CHIP R 10K J 1/16W		
R616-618			RK73FB2A1R0J	CHIP R 1 J 1/10W		
R619-621			RK73GB1J103J	CHIP R 10K J 1/16W		
R622			RK73FB2A1R0J	CHIP R 1 J 1/10W		

L : Scandinavia K : USA P : Canada R : Mexico C : China I : Malaysia
Y : PX(Far East,Hawaii) T : England E : Europe G : Germany V : China(Shanghai)
Y : AAFES(Europe) X : Australia Q : Russia H : Korea M : Other Areas Δ indicates safety critical components .

PARTS LIST

KRF-X9995D/X9995D-S/VR-5700/5900

* New Parts
Parts without **Parts No.** are not supplied.
Les articles non mentionnés dans le **Parts No.** ne sont pas fournis.
Teile ohne **Parts No.** werden nicht geliefert.

21

Ref. No	Add-ress	New Parts	Parts No.	Description	Desti-nation	Re-marks
R623			RK73GB1J105J	CHIP R 1.0M J 1/16W		
R624			RK73GB1J102J	CHIP R 1.0K J 1/16W		
R625			RK73FB2A1R0J	CHIP R 1 J 1/10W		
R626			RK73GB1J103J	CHIP R 10K J 1/16W		
R627,628			RK73FB2A1R0J	CHIP R 1 J 1/10W		
R629			RK73GB1J103J	CHIP R 10K J 1/16W		
R630-639			RK73GB1J101J	CHIP R 100 J 1/16W		
R640-648			RK73FB2A1R0J	CHIP R 1 J 1/10W		
R649-652			RK73GB1J101J	CHIP R 100 J 1/16W		
R653			RK73FB2A1R0J	CHIP R 1 J 1/10W		
R654,655			RK73GB1J103J	CHIP R 10K J 1/16W		
R656			RK73FB2A1R0J	CHIP R 1 J 1/10W		
R657			RK73GB1J103J	CHIP R 10K J 1/16W		
R658			RK73GB1J101J	CHIP R 100 J 1/16W		
R659-664			RK73FB2A1R0J	CHIP R 1 J 1/10W		
R665-667			RK73GB1J101J	CHIP R 100 J 1/16W		
R668			RK73FB2A1R0J	CHIP R 1 J 1/10W		
R669-671			RK73GB1J101J	CHIP R 100 J 1/16W		
R672			RK73GB1J103J	CHIP R 10K J 1/16W		
R673			RK73GB1J101J	CHIP R 100 J 1/16W		
R674			RK73FB2A100J	CHIP R 10 J 1/10W		
R675			RK73FB2A1R0J	CHIP R 1 J 1/10W		
R701-708			RK73GB1J101J	CHIP R 100 J 1/16W		
R709,710			RK73GB1J472J	CHIP R 4.7K J 1/16W		
R711-719			RK73GB1J101J	CHIP R 100 J 1/16W		
R720			RK73GB1J472J	CHIP R 4.7K J 1/16W		
R721-723			RK73GB1J101J	CHIP R 100 J 1/16W		
R724-727			RK73FB2A1R0J	CHIP R 1 J 1/10W		
R728-731			RK73GB1J101J	CHIP R 100 J 1/16W		
R732-734			RK73FB2A1R0J	CHIP R 1 J 1/10W		
R801-854			RK73GB1J473J	CHIP R 47K J 1/16W		
R855			RK73GB1J105J	CHIP R 1.0M J 1/16W		
R856			RK73FB2A1R0J	CHIP R 1 J 1/10W		
R857			RK73GB1J183J	CHIP R 18K J 1/16W		
R858			RK73GB1J123J	CHIP R 12K J 1/16W		
R859			RK73GB1J183J	CHIP R 18K J 1/16W		
R860			RK73GB1J473J	CHIP R 47K J 1/16W		
R861			RK73FB2A1R0J	CHIP R 1 J 1/10W		
R862-864			RK73GB1J473J	CHIP R 47K J 1/16W		
R865,866			RK73GB1J102J	CHIP R 1.0K J 1/16W		
R867			RK73FB2A1R0J	CHIP R 1 J 1/10W		
R868,869			RK73GB1J473J	CHIP R 47K J 1/16W		
R871-875			RK73GB1J471J	CHIP R 470 J 1/16W		
R876			RK73GB1J512J	CHIP R 5.1K J 1/16W		
R877-895			RK73GB1J471J	CHIP R 470 J 1/16W		
R896-900			RK73GB1J221J	CHIP R 220 J 1/16W		
R901-905			RK73GB1J471J	CHIP R 470 J 1/16W		
R911-915			RK73GB1J473J	CHIP R 47K J 1/16W		
R951-954			RK73FB2A181J	CHIP R 180 J 1/10W		
R955-960			RK73FB2A1R0J	CHIP R 1 J 1/10W		
R961			RK73GB1J102J	CHIP R 1.0K J 1/16W		
R962-967			RK73FB2A1R0J	CHIP R 1 J 1/10W		
R969-972			RK73FB2A1R0J	CHIP R 1 J 1/10W		
R973-976			RK73FB2A390J	CHIP R 39 J 1/10W		
R999			RK73GB1J1R0J	CHIP R 1 J 1/16W		

L : Scandinavia K : USA P : Canada R : Mexico C : China I : Malaysia
Y : PX(Far East,Hawaii) T : England E : Europe G : Germany V : China(Shanghai)
Y : AAFES(Europe) X : Australia Q : Russia H : Korea M : Other Areas Δ indicates safety critical components .

* New Parts
Parts without **Parts No.** are not supplied.
Les articles non mentionnés dans le **Parts No.** ne sont pas fournis.
Teile ohne **Parts No.** werden nicht geliefert.

22

Ref. No	Add-ress	New Parts	Parts No.	Description	Desti-nation	Re-marks
D3 -6			DA204U	DIODE		
D3 -6			1SS302	DIODE		
IC1 -4			TC74HCU04AF	IC(HEX INVERTER SMD)		
IC5			TC74HC151AF	MOS-IC		
IC6		*	AK4112BVF	MOS-IC		
IC7		*	AK5383VF	MOS-IC		
IC8 ,9			NJM4565MD	IC(OP AMP X2)		
IC11		*	AK4393-VF	MOS-IC		
IC11			AK4393VF	MOS-IC		
IC12,13			NJM4565MD	IC(OP AMP X2)		
IC14			AK4393-VF	MOS-IC		
IC14		*	AK4393VF	MOS-IC		
IC15,16			NJM4565MD	IC(OP AMP X2)		
IC17			AK4393-VF	MOS-IC		
IC17		*	AK4393VF	MOS-IC		
IC18,19			NJM4565MD	IC(OP AMP X2)		
IC20			AK4393-VF	MOS-IC		
IC20		*	AK4393VF	MOS-IC		
IC21,22			NJM4565MD	IC(OP AMP X2)		
IC31		*	ADSST-A-3525	MOS-IC		
IC32		*	49BV008A1ALA	MOS-IC		
IC33,34			HY57V16160DTC	MEMORY IC		
IC35			TC7S04F	IC(2CH NAND GATE)		
IC36,37			TC7SHU04FU	MOS-IC		
IC38			TC74HC08AF	MOS-IC		
IC39,40		*	TC74LVX573F	MOS-IC		
IC41			TC7SH32F	MOS-IC		
IC42			TC7SH02F	MOS-IC		
IC43		*	UPD784224K507	MI-COM IC		
IC44			TC74VHC125F	MOS-IC		
IC45			TC7WH34FK	MOS-IC		
IC51			UPC29L33T	ANALOGUE IC		
IC52		*	PQ3DZ13	ANALOGUE IC		
IC53,54		*	UPC29M05T	ANALOGUE IC		
CONTROL (X11-3890-11)						
C1 -14			CC73GCH1H221J	CHIP C 220PF	J	
C45 -48			CC73GCH1H101J	CHIP C 100PF	J	
C49 ,50			CE04KW1H470M	ELECTRO 47UF	50WV	
C53 ,54			CE04KW1H100M	ELECTRO 10UF	50WV	
C55 ,56			CC73GCH1H221J	CHIP C 220PF	J	
C57 ,58			CE04KW1A101M	ELECTRO 100UF	10WV	
C61 ,62			CQ93FMG1H123J	MYLAR 0.012UF	J	
C63 ,64			CQ93FMG1H332J	MYLAR 3300PF	J	
C65 ,66			CE04KW1H4R7M	ELECTRO 4.7UF	50WV	
C67 ,68			CC73GCH1H101J	CHIP C 100PF	J	
C69 ,70			CC73GCH1H181J	CHIP C 180PF	J	
C71 -78			CC73GCH1H101J	CHIP C 100PF	J	
C81 -84			CC73GCH1H101J	CHIP C 100PF	J	
C85 ,86			CE04KW1H4R7M	ELECTRO 4.7UF	50WV	
C87 -90			CC73GCH1H101J	CHIP C 100PF	J	
C91 ,92			CE04KW1H010M	ELECTRO 1.0UF	50WV	
C93 ,94			CE04KW1H2R2M	ELECTRO 2.2UF	50WV	
C95 -100			CC73GCH1H101J	CHIP C 100PF	J	
C101,102			CE04KW1H4R7M	ELECTRO 4.7UF	50WV	
C103,104			CC73GCH1H101J	CHIP C 100PF	J	

L : Scandinavia K : USA P : Canada R : Mexico C : China I : Malaysia
Y : PX(Far East,Hawaii) T : England E : Europe G : Germany V : China(Shanghai)
Y : AAFES(Europe) X : Australia Q : Russia H : Korea M : Other Areas Δ indicates safety critical components .

* New Parts
Parts without **Parts No.** are not supplied.
Les articles non mentionnés dans le **Parts No.** ne sont pas fournis.
Teile ohne **Parts No.** werden nicht geliefert.

23

Ref. No	Add-ress	New Parts	Parts No.	Description	Desti-nation	Re-marks
C105-107			CC73GCH1H102J	CHIP C	1000PF	J
C108			CE04KW1H220M	ELECTRO	22UF	50WV
C111,112			CC73GCH1H101J	CHIP C	100PF	J
C113,114			CC73GCH1H561J	CHIP C	560PF	J
C115,116			CC73GCH1H101J	CHIP C	100PF	J
C117-120			CK73FB1C104K	CHIP C	0.10UF	K
C121,122			CC73GCH1H101J	CHIP C	100PF	J
C123,124			CE04KW1H4R7M	ELECTRO	4.7UF	50WV
C125,126			CC45FSL1H820J	CERAMIC	82PF	J
C127,128			CE04KW1H220M	ELECTRO	22UF	50WV
C129,130			CC45FSL1H330J	CERAMIC	33PF	J
C131,132			CC73GCH1H101J	CHIP C	100PF	J
C133			CE04KW1H100M	ELECTRO	10UF	50WV
C135			CC73GCH1H101J	CHIP C	100PF	J
C137			CC45FSL1H020C	CERAMIC	2.0PF	C
C138			CC45FSL1H030C	CERAMIC	3.0PF	C
C139,140			CC73GCH1H101J	CHIP C	100PF	J
C141,142			CE04KW1H4R7M	ELECTRO	4.7UF	50WV
C143,144			CC73GCH1H101J	CHIP C	100PF	J
C145,146			CC73GCH1H561J	CHIP C	560PF	J
C147-150			CK73FB1C104K	CHIP C	0.10UF	K
C151,152			CE04KW1H4R7M	ELECTRO	4.7UF	50WV
C153,154			CC45FSL1H470J	CERAMIC	47PF	J
C155,156			CE04KW1H220M	ELECTRO	22UF	50WV
C157,158			CC45FSL1H330J	CERAMIC	33PF	J
C159-163			CC73GCH1H101J	CHIP C	100PF	J
C165			CC45FSL1H020C	CERAMIC	2.0PF	C
C166			CC45FSL1H030C	CERAMIC	3.0PF	C
C167			CE04KW1H100M	ELECTRO	10UF	50WV
C169,170			CC73GCH1H101J	CHIP C	100PF	J
C181,182			CE04KW1H4R7M	ELECTRO	4.7UF	50WV
C183,184			CC73GCH1H101J	CHIP C	100PF	J
C191,192			CE04KW1H4R7M	ELECTRO	4.7UF	50WV
C193,194			CC45FSL1H470J	CERAMIC	47PF	J
C195,196			CE04KW1H220M	ELECTRO	22UF	50WV
C197			CC45FSL1H330J	CERAMIC	33PF	J
C198			CC45FSL1H101J	CERAMIC	100PF	J
C199-204			CC73GCH1H101J	CHIP C	100PF	J
C205,206			CC45FSL1H020C	CERAMIC	2.0PF	C
C207			CE04KW1H100M	ELECTRO	10UF	50WV
C209,210			CC73GCH1H101J	CHIP C	100PF	J
C211,212			CE04KW1H4R7M	ELECTRO	4.7UF	50WV
C213-216			CC73GCH1H101J	CHIP C	100PF	J
C221,222			CE04KW1H4R7M	ELECTRO	4.7UF	50WV
C223,224			CC45FSL1H470J	CERAMIC	47PF	J
C225,226			CE04KW1H220M	ELECTRO	22UF	50WV
C227,228			CC45FSL1H330J	CERAMIC	33PF	J
C229-233			CC73GCH1H101J	CHIP C	100PF	J
C234			CE04KW1H100M	ELECTRO	10UF	50WV
C235			CC45FSL1H020C	CERAMIC	2.0PF	C
C236			CC45FSL1H030C	CERAMIC	3.0PF	C
C301-318			CC73GCH1H221J	CHIP C	220PF	J
C351-356			CE04KW1H2R2M	ELECTRO	2.2UF	50WV
C357-376			CC73GCH1H101J	CHIP C	100PF	J
C377,378			CK73GB1H103K	CHIP C	0.010UF	K

L : Scandinavia K : USA P : Canada R : Mexico C : China I : Malaysia
Y : PX(Far East,Hawaii) T : England E : Europe G : Germany V : China(Shanghai)
Y : AAFES(Europe) X : Australia Q : Russia H : Korea M : Other Areas Δ indicates safety critical components .

* New Parts
Parts without **Parts No.** are not supplied.
Les articles non mentionnés dans le **Parts No.** ne sont pas fournis.
Teile ohne **Parts No.** werden nicht geliefert.

24

Ref. No	Add-ress	New Parts	Parts No.	Description	Desti-nation	Re-marks
C381,382			CE04KW1H220M	ELECTRO	22UF	50WV
C383,384			CE04KW1H100M	ELECTRO	10UF	50WV
C401,402			CE04KW1H2R2M	ELECTRO	2.2UF	50WV
C403-410			CC73GCH1H101J	CHIP C	100PF	J
C411,412			CE04KW1H220M	ELECTRO	22UF	50WV
C413-415			CE04KW1H4R7M	ELECTRO	4.7UF	50WV
C421			CE04KW1H100M	ELECTRO	10UF	50WV
C422,423			CC73GCH1H101J	CHIP C	100PF	J
C425			CE04KW1H220M	ELECTRO	22UF	50WV
C427			CC73GCH1H101J	CHIP C	100PF	J
C431-440			CC73GCH1H101J	CHIP C	100PF	J
C441,442			CE04KW1H220M	ELECTRO	22UF	50WV
C443,444			CC73GCH1H101J	CHIP C	100PF	J
C451,452			CE04KW1H2R2M	ELECTRO	2.2UF	50WV
C453,454			CC73GCH1H101J	CHIP C	100PF	J
C455,456			CE04KW1H220M	ELECTRO	22UF	50WV
C457-462			CC73GCH1H101J	CHIP C	100PF	J
C463,464			CE04KW1H4R7M	ELECTRO	4.7UF	50WV
C465,466			CC73GCH1H101J	CHIP C	100PF	J
C467			CE04KW1H100M	ELECTRO	10UF	50WV
C469,470			CC73GCH1H101J	CHIP C	100PF	J
C471,472			CE04KW1H010M	ELECTRO	1.0UF	50WV
C473,474			CC73GCH1H561J	CHIP C	560PF	J
C475,476			CE04KW1H010M	ELECTRO	1.0UF	50WV
C477,478			CC73GCH1H270J	CHIP C	27PF	J
C479,480			CK73GB1H562K	CHIP C	5600PF	K
C481,482			CK73FB1H183K	CHIP C	0.018UF	K
C483,484			CE04KW1H100M	ELECTRO	10UF	50WV
C485,486			CK73FB1H153K	CHIP C	0.015UF	K
C487,488			CK73FB1H683K	CHIP C	0.068UF	K
C489,490			CC73GCH1H821J	CHIP C	820PF	J
C491-495			CC73GCH1H101J	CHIP C	100PF	J
C501-506			CC73GCH1H101J	CHIP C	100PF	J
C509,510			CC73GCH1H101J	CHIP C	100PF	J
C513-518			CC73GCH1H101J	CHIP C	100PF	J
C549,550			CC73GCH1H101J	CHIP C	100PF	J
C551-554			CE04KW1H4R7M	ELECTRO	4.7UF	50WV
C555,556			CC45FSL1H101J	CERAMIC	100PF	J
C557,558			CE04KW1H220M	ELECTRO	22UF	50WV
C559,560			CC45FSL1H330J	CERAMIC	33PF	J
C561,562			CC73GCH1H101J	CHIP C	100PF	J
C563			CC45FSL1H020C	CERAMIC	2.0PF	C
C564			CC45FSL1H030C	CERAMIC	3.0PF	C
C565,566			CK73GB1H103K	CHIP C	0.010UF	K
C567			CC73GCH1H101J	CHIP C	100PF	J
C568			CE04KW1H100M	ELECTRO	10UF	50WV
CN1			E40-8319-05	FLAT CABLE CONNECTOR		
CN2			E40-8250-05	FLAT CABLE CONNECTOR		
CN3			E40-8354-05	FLAT CABLE CONNECTOR		
CN11			E40-8318-05	FLAT CABLE CONNECTOR		
CN12,13		*	E40-9835-05	SOCKET FOR PIN ASSY		
J1 ,2			E63-1113-05	PIN JACK		
J11 ,12			E63-1111-05	PIN JACK		
J13			E63-1115-05	PIN JACK		

L : Scandinavia K : USA P : Canada R : Mexico C : China I : Malaysia
Y : PX(Far East,Hawaii) T : England E : Europe G : Germany V : China(Shanghai)
Y : AAFES(Europe) X : Australia Q : Russia H : Korea M : Other Areas Δ indicates safety critical components .

PARTS LIST

KRF-X9995D/X9995D-S/VR-5700/5900

* New Parts

Parts without **Parts No.** are not supplied.Les articles non mentionnés dans le **Parts No.** ne sont pas fournis.Teile ohne **Parts No.** werden nicht geliefert.

25

Ref. No	Add-ress	New Parts	Parts No.	Description	Desti-nation	Re-marks
R1 ,2			RK73GB1J102J	CHIP R	1.0K	J 1/16W
R3 ,4			RK73GB1J222J	CHIP R	2.2K	J 1/16W
R5 ,10			RK73GB1J102J	CHIP R	1.0K	J 1/16W
R11 ,12			RK73GB1J222J	CHIP R	2.2K	J 1/16W
R13 ,14			RK73GB1J102J	CHIP R	1.0K	J 1/16W
R15 ,28			RK73GB1J474J	CHIP R	470K	J 1/16W
R45 ,48			RK73GB1J102J	CHIP R	1.0K	J 1/16W
R51 ,52			RK73GB1J224J	CHIP R	220K	J 1/16W
R53 ,54			RK73GB1J222J	CHIP R	2.2K	J 1/16W
R55 ,56			RK73GB1J303J	CHIP R	30K	J 1/16W
R57 ,58			RK73GB1J361J	CHIP R	360	J 1/16W
R59 ,60			RK73GB1J101J	CHIP R	100	J 1/16W
R61 ,62			RK73GB1J274J	CHIP R	270K	J 1/16W
R63 ,64			RK73GB1J223J	CHIP R	22K	J 1/16W
R65 ,66			RK73GB1J473J	CHIP R	47K	J 1/16W
R67 ,68			RK73GB1J102J	CHIP R	1.0K	J 1/16W
R72			RK73GB1J103J	CHIP R	10K	J 1/16W
R75 ,76			RK73GB1J102J	CHIP R	1.0K	J 1/16W
R77 ,78			RK73GB1J100J	CHIP R	10	J 1/16W
R80			RK73GB1J681J	CHIP R	680	J 1/16W
R81 ,82			RK73GB1J472J	CHIP R	4.7K	J 1/16W
R83 ,84			RK73GB1J102J	CHIP R	1.0K	J 1/16W
R85 ,86			RK73GB1J101J	CHIP R	100	J 1/16W
R87 ,88			RK73GB1J224J	CHIP R	220K	J 1/16W
R89 ,90			RK73GB1J471J	CHIP R	470	J 1/16W
R91 ,92			RK73GB1J474J	CHIP R	470K	J 1/16W
R93 ,94			RK73GB1J471J	CHIP R	470	J 1/16W
R95 ,96			RK73GB1J224J	CHIP R	220K	J 1/16W
R97 ,98			RK73GB1J101J	CHIP R	100	J 1/16W
R99 ,100			RK73GB1J470J	CHIP R	47	J 1/16W
R111,112			RK73GB1J104J	CHIP R	100K	J 1/16W
R113,114			RK73GB1J224J	CHIP R	220K	J 1/16W
R115,116			RK73GB1J822J	CHIP R	8.2K	J 1/16W
R117,118			RK73GB1J470J	CHIP R	47	J 1/16W
R119,120			RK73GB1J105J	CHIP R	1.0M	J 1/16W
R121,122			RK73GB1J124J	CHIP R	120K	J 1/16W
R123,124			RK73GB1J302J	CHIP R	3.0K	J 1/16W
R125,126			RK73GB1J133J	CHIP R	13K	J 1/16W
R127,128			RK73GB1J100J	CHIP R	10	J 1/16W
R129			RK73GB1J102J	CHIP R	1.0K	J 1/16W
R130			RK73GB1J103J	CHIP R	10K	J 1/16W
R131,132			RK73GB1J2R2J	CHIP R	2.2	J 1/16W
R133,134			RK73GB1J102J	CHIP R	1.0K	J 1/16W
R141,142			RK73GB1J104J	CHIP R	100K	J 1/16W
R143,144			RK73GB1J224J	CHIP R	220K	J 1/16W
R145,146			RK73GB1J822J	CHIP R	8.2K	J 1/16W
R147,148			RK73GB1J470J	CHIP R	47	J 1/16W
R149,150			RK73GB1J102J	CHIP R	1.0K	J 1/16W
R151,152			RK73GB1J124J	CHIP R	120K	J 1/16W
R153,154			RK73GB1J103J	CHIP R	10K	J 1/16W
R155,156			RK73GB1J332J	CHIP R	3.3K	J 1/16W
R157,158			RK73GB1J163J	CHIP R	16K	J 1/16W
R159,160			RK73GB1J133J	CHIP R	13K	J 1/16W
R161,162			RK73GB1J470J	CHIP R	47	J 1/16W
R163,164			RK73GB1J100J	CHIP R	10	J 1/16W

L : Scandinavia K : USA P : Canada R : Mexico C : China I : Malaysia

Y : PX(Far East,Hawaii) T : England E : Europe G : Germany V : China(Shanghai)

Y : AAFES(Europe) X : Australia Q : Russia H : Korea M : Other Areas Δ indicates safety critical components .

* New Parts

Parts without **Parts No.** are not supplied.Les articles non mentionnés dans le **Parts No.** ne sont pas fournis.Teile ohne **Parts No.** werden nicht geliefert.

26

Ref. No	Add-ress	New Parts	Parts No.	Description	Desti-nation	Re-marks
R165			RK73GB1J102J	CHIP R	1.0K	J 1/16W
R166			RK73GB1J472J	CHIP R	4.7K	J 1/16W
R167,168			RK73GB1J105J	CHIP R	1.0M	J 1/16W
R169			RK73GB1J472J	CHIP R	4.7K	J 1/16W
R171,172			RK73GB1J100J	CHIP R	10	J 1/16W
R173,174			RK73GB1J2R2J	CHIP R	2.2	J 1/16W
R181,182			RK73GB1J104J	CHIP R	100K	J 1/16W
R183,184			RK73GB1J102J	CHIP R	1.0K	J 1/16W
R187,188			RK73GB1J470J	CHIP R	47	J 1/16W
R189,190			RK73GB1J105J	CHIP R	1.0M	J 1/16W
R191,192			RK73GB1J124J	CHIP R	120K	J 1/16W
R193,194			RK73GB1J103J	CHIP R	10K	J 1/16W
R195			RK73GB1J332J	CHIP R	3.3K	J 1/16W
R196			RK73GB1J472J	CHIP R	4.7K	J 1/16W
R197			RK73GB1J163J	CHIP R	16K	J 1/16W
R198			RK73GB1J153J	CHIP R	15K	J 1/16W
R199			RK73GB1J133J	CHIP R	13K	J 1/16W
R200			RK73GB1J333J	CHIP R	33K	J 1/16W
R201,202			RK73GB1J100J	CHIP R	10	J 1/16W
R203			RK73GB1J470J	CHIP R	47	J 1/16W
R204			RK73GB1J102J	CHIP R	1.0K	J 1/16W
R205,206			RK73GB1J2R2J	CHIP R	2.2	J 1/16W
R211,212			RK73GB1J104J	CHIP R	100K	J 1/16W
R213,214			RK73GB1J102J	CHIP R	1.0K	J 1/16W
R217,218			RK73GB1J470J	CHIP R	47	J 1/16W
R219,220			RK73GB1J105J	CHIP R	1.0M	J 1/16W
R221,222			RK73GB1J124J	CHIP R	120K	J 1/16W
R223,224			RK73GB1J103J	CHIP R	10K	J 1/16W
R225,226			RK73GB1J332J	CHIP R	3.3K	J 1/16W
R227,228			RK73GB1J163J	CHIP R	16K	J 1/16W
R229,230			RK73GB1J133J	CHIP R	13K	J 1/16W
R231,232			RK73GB1J470J	CHIP R	47	J 1/16W
R233,234			RK73GB1J100J	CHIP R	10	J 1/16W
R235			RK73GB1J102J	CHIP R	1.0K	J 1/16W
R237,238			RK73GB1J2R2J	CHIP R	2.2	J 1/16W
R301,302			RK73GB1J222J	CHIP R	2.2K	J 1/16W
R303,304			RK73GB1J102J	CHIP R	1.0K	J 1/16W
R305,306			RK73GB1J222J	CHIP R	2.2K	J 1/16W
R307-318			RK73GB1J102J	CHIP R	1.0K	J 1/16W
R319-336			RK73GB1J474J	CHIP R	470K	J 1/16W
R351-356			RK73GB1J471J	CHIP R	470	J 1/16W
R357-362			RK73GB1J224J	CHIP R	220K	J 1/16W
R363-366			RK73GB1J101J	CHIP R	100	J 1/16W
R367			RK73GB1J472J	CHIP R	4.7K	J 1/16W
R368			RK73GB1J101J	CHIP R	100	J 1/16W
R369-372			RK73GB1J470J	CHIP R	47	J 1/16W
R373			RK73GB1J222J	CHIP R	2.2K	J 1/16W
R381,382			RK73GB1J470J	CHIP R	47	J 1/16W
R383,384			RK73GB1J224J	CHIP R	220K	J 1/16W
R385-390			RK73GB1J472J	CHIP R	4.7K	J 1/16W
R391,392			RK73GB1J622J	CHIP R	6.2K	J 1/16W
R401,402			RK73GB1J224J	CHIP R	220K	J 1/16W
R403,404			RK73GB1J101J	CHIP R	100	J 1/16W
R421			RK73GB1J224J	CHIP R	220K	J 1/16W
R422			RK73GB1J101J	CHIP R	100	J 1/16W

L : Scandinavia K : USA P : Canada R : Mexico C : China I : Malaysia

Y : PX(Far East,Hawaii) T : England E : Europe G : Germany V : China(Shanghai)

Y : AAFES(Europe) X : Australia Q : Russia H : Korea M : Other Areas Δ indicates safety critical components .

* New Parts
 Parts without **Parts No.** are not supplied.
 Les articles non mentionnés dans le **Parts No.** ne sont pas fournis.
 Teile ohne **Parts No.** werden nicht geliefert.

27

Ref. No	Add-ress	New Parts	Parts No.	Description	Desti-nation	Re-marks
R423,424			RK73GB1J472J	CHIP R 4.7K J 1/16W		
R425			RK73GB1J470J	CHIP R 4.7K J 1/16W		
R427,428			RK73GB1J104J	CHIP R 100K J 1/16W		
R429,430			RK73GB1J100J	CHIP R 10 J 1/16W		
R431,432			RK73GB1J152J	CHIP R 1.5K J 1/16W		
R433,434			RK73GB1J272J	CHIP R 2.7K J 1/16W		
R435-442			RK73GB1J472J	CHIP R 4.7K J 1/16W		
R443,444			RK73GB1J104J	CHIP R 100K J 1/16W		
R451			RK73GB1J332J	CHIP R 3.3K J 1/16W		
R452			RK73GB1J103J	CHIP R 10K J 1/16W		
R453			RK73GB1J152J	CHIP R 1.5K J 1/16W		
R454			RK73GB1J103J	CHIP R 10K J 1/16W		
R455,456			RK73GB1J102J	CHIP R 1.0K J 1/16W		
R457,458			RK73GB1J224J	CHIP R 220K J 1/16W		
R459,460			RK73GB1J472J	CHIP R 4.7K J 1/16W		
R461,462			RK73GB1J224J	CHIP R 220K J 1/16W		
R463,464			RK73GB1J472J	CHIP R 4.7K J 1/16W		
R465,466			RK73GB1J470J	CHIP R 4.7K J 1/16W		
R467-469			RK73GB1J104J	CHIP R 100K J 1/16W		
R471,472			RK73GB1J822J	CHIP R 8.2K J 1/16W		
R473,474			RK73GB1J202J	CHIP R 2.0K J 1/16W		
R475,476			RK73GB1J124J	CHIP R 120K J 1/16W		
R477,478			RK73GB1J433J	CHIP R 43K J 1/16W		
R479,480			RK73GB1J184J	CHIP R 180K J 1/16W		
R481,482			RK73GB1J394J	CHIP R 390K J 1/16W		
R483-486			RK73GB1J392J	CHIP R 3.9K J 1/16W		
R487,488			RK73GB1J821J	CHIP R 820 J 1/16W		
R489,490			RK73GB1J163J	CHIP R 16K J 1/16W		
R491,492			RK73GB1J684J	CHIP R 680K J 1/16W		
R493,494			RK73GB1J223J	CHIP R 22K J 1/16W		
R495,496			RK73GB1J102J	CHIP R 1.0K J 1/16W		
R497			RK73GB1J103J	CHIP R 10K J 1/16W		
R498,499			RK73GB1J472J	CHIP R 4.7K J 1/16W		
R500,501			RK73GB1J102J	CHIP R 1.0K J 1/16W		
R502			RK73GB1J103J	CHIP R 10K J 1/16W		
R503			RK73GB1J102J	CHIP R 1.0K J 1/16W		
R504			RK73GB1J103J	CHIP R 10K J 1/16W		
R505,506			RK73GB1J472J	CHIP R 4.7K J 1/16W		
R507-520			RK73GB1J102J	CHIP R 1.0K J 1/16W		
R549-552			RK73GB1J104J	CHIP R 100K J 1/16W		
R553,554			RK73GB1J103J	CHIP R 10K J 1/16W		
R555,556			RK73GB1J332J	CHIP R 3.3K J 1/16W		
R557,558			RK73GB1J163J	CHIP R 16K J 1/16W		
R559,560			RK73GB1J133J	CHIP R 13K J 1/16W		
R561,562			RK73GB1J470J	CHIP R 4.7K J 1/16W		
R563			RK73GB1J103J	CHIP R 10K J 1/16W		
R564			RK73GB1J102J	CHIP R 1.0K J 1/16W		
R565,566			RK73GB1J2R2J	CHIP R 2.2 J 1/16W		
R567,568			RK73GB1J100J	CHIP R 10 J 1/16W		
W201-204			R92-1963-05	JUMPER WIRE (RESISTOR TYPE)		
W205,206			R92-0679-05	CHIP R 0 OHM		
W207-215			R92-1963-05	JUMPER WIRE (RESISTOR TYPE)		
W501-539			R92-1963-05	JUMPER WIRE (RESISTOR TYPE)		
D3 ,4			MA111	DIODE		

L : Scandinavia K : USA P : Canada R : Mexico C : China I : Malaysia
 Y : PX(Far East,Hawaii) T : England E : Europe G : Germany V : China(Shanghai)
 Y : AAFES(Europe) X : Australia Q : Russia H : Korea M : Other Areas Δ indicates safety critical components .

* New Parts
 Parts without **Parts No.** are not supplied.
 Les articles non mentionnés dans le **Parts No.** ne sont pas fournis.
 Teile ohne **Parts No.** werden nicht geliefert.

28

Ref. No	Add-ress	New Parts	Parts No.	Description	Desti-nation	Re-marks
D5 -8			DA204U	DIODE		
D5 -8			1S5302	DIODE		
IC1			NJM4580ED	ANALOGUE IC		
IC2			NJU7312AM	MOS-IC		
IC3			NJU7313AM	ANALOGUE IC		
IC4 ,5			NJM4565M	ANALOGUE IC		
IC6		*	TC9459N	MOS-IC		
IC7			NJM4565M	ANALOGUE IC		
IC8		*	TC9459N	MOS-IC		
IC9			NJM4565MD	IC(OP AMP X2)		
IC10		*	TC9459N	MOS-IC		
IC11			NJM4565MD	IC(OP AMP X2)		
IC12		*	TC9459N	MOS-IC		
IC13			NJM4565MD	IC(OP AMP X2)		
IC21			NJU7312AM	MOS-IC		
IC22			NJU7313AM	ANALOGUE IC		
IC23			NJU7311AM	MOS-IC		
IC24			NJU7313AM	ANALOGUE IC		
IC25-28			NJM4565MD	IC(OP AMP X2)		
IC29-33			NJM4565M	ANALOGUE IC		
IC34			TC9184AP	MOS-IC		
IC35		*	TC9459N	MOS-IC		
IC36			NJM4565M	ANALOGUE IC		
Q1 -8			2SC2878(B)	TRANSISTOR		
Q11 ,12			2SC2878(B)	TRANSISTOR		
Q13			2SA1576A(R,S)	TRANSISTOR		
Q13			2SA1586(Y,GR)	TRANSISTOR		
Q14			DTC124EUA	DIGITAL TRANSISTOR		
Q14			UN5212	DIGITAL TRANSISTOR		
Q15 -18			2SC2878(B)	TRANSISTOR		
SUB (X13-7840-13)						
C4			C90-1826-05	BACKUP-C	0.047F	5.5WV
C5			CE04KW1A101M	ELECTRO	100UF	10WV
C6			CK73GF1E104Z	CHIP C	0.10UF	Z
C7			CK73GB1H103K	CHIP C	0.010UF	K
C8			CE04KW1H010M	ELECTRO	1.0UF	50WV
C9 ,10			CK73GB1H103K	CHIP C	0.010UF	K
C11			CE04KW1E470M	ELECTRO	47UF	25WV
C12			CE04KW1A101M	ELECTRO	100UF	10WV
C13 ,14			CK73GF1E104Z	CHIP C	0.10UF	Z
C20			CK73GF1E104Z	CHIP C	0.10UF	Z
C21 ,22			CC73GCH1H101J	CHIP C	100PF	J
C23 ,24			CK73GB1H103K	CHIP C	0.010UF	K
C41			CE04KW1E102M	ELECTRO	1000UF	25WV
C42			CE04KW1H100M	ELECTRO	10UF	50WV
C45 -50			CE04KW1H100M	ELECTRO	10UF	50WV
C51			CE04KW1E221M	ELECTRO	220UF	25WV
C52			CE04KW1E101M	ELECTRO	100UF	25WV
C98 ,99			CE04KW1H100M	ELECTRO	10UF	50WV
C101,102			CC73GCH1H560J	CHIP C	56PF	J
C110			CK73GB1H472K	CHIP C	4700PF	K
C201			CE04KW1H010M	ELECTRO	1.0UF	50WV
C202			CK73GB1H472K	CHIP C	4700PF	K
C229			CC73GCH1H102J	CHIP C	1000PF	J
C231			CE04KW1H100M	ELECTRO	10UF	50WV

L : Scandinavia K : USA P : Canada R : Mexico C : China I : Malaysia
 Y : PX(Far East,Hawaii) T : England E : Europe G : Germany V : China(Shanghai)
 Y : AAFES(Europe) X : Australia Q : Russia H : Korea M : Other Areas Δ indicates safety critical components .

PARTS LIST

KRF-X9995D/X9995D-S/VR-5700/5900

* New Parts
Parts without **Parts No.** are not supplied.
Les articles non mentionnés dans le **Parts No.** ne sont pas fournis.
Teile ohne **Parts No.** werden nicht geliefert.

29

Ref. No	Add-ress	New Parts	Parts No.	Description	Desti-nation	Re-marks
C231			CE04KW1H100M	ELECTRO	10UF	50WV
C232			CC73GCH1H331J	CHIP C	330PF	J
C232			CC73GCH1H331J	CHIP C	330PF	J
C233			CC73GCH1H561J	CHIP C	560PF	J
C233			CC73GCH1H561J	CHIP C	560PF	J
C234,235			CC73GCH1H220J	CHIP C	22PF	J
C234,235			CC73GCH1H220J	CHIP C	22PF	J
C236			CE04KW1H100M	ELECTRO	10UF	50WV
C236			CE04KW1H100M	ELECTRO	10UF	50WV
C237			CK73GB1H472K	CHIP C	4700PF	K
C237			CK73GB1H472K	CHIP C	4700PF	K
C300			CK45FF1H103Z	CERAMIC	0.010UF	Z
C301,302			CE04KW1V102M	ELECTRO	1000UF	35WV
C307			CC73GCH1H102J	CHIP C	1000PF	J
C308			CC73GCH1H101J	CHIP C	100PF	J
C309			CE04KW1H100M	ELECTRO	10UF	50WV
C310			CE04KW1E221M	ELECTRO	220UF	25WV
C311,312			CE04KW1E470M	ELECTRO	47UF	25WV
C320			CK45FF1H103Z	CERAMIC	0.010UF	Z
C321			CE04KW1C472M	ELECTRO	4700UF	16WV
C322			CE04KW1E101M	ELECTRO	100UF	25WV
C323			CE04KW1A101M	ELECTRO	100UF	10WV
C328,329			CE04KW1E470M	ELECTRO	47UF	25WV
C330			CK45FF1H103Z	CERAMIC	0.010UF	Z
C331			CE04KW1V102M	ELECTRO	1000UF	35WV
C333,334			CE04KW1E470M	ELECTRO	47UF	25WV
C410			CE04KW1A101M	ELECTRO	100UF	10WV
C501-508			CC73GCH1H101J	CHIP C	100PF	J
C509,510			CE04KW1A471M	ELECTRO	470UF	10WV
C511-515			CE04KW1A101M	ELECTRO	100UF	10WV
C517			CK73GB1H103K	CHIP C	0.010UF	K
C518			CE04KW1A101M	ELECTRO	100UF	10WV
C519			CE04KW1H010M	ELECTRO	1.0UF	50WV
C521			CE04KW1E470M	ELECTRO	47UF	25WV
C522			CE04KW1A471M	ELECTRO	470UF	10WV
C523-527			CE04KW1A101M	ELECTRO	100UF	10WV
C529			CK73GB1H182K	CHIP C	1800PF	K
C529			CK73GB1H182K	CHIP C	1800PF	K
C530			CC73GCH1H102J	CHIP C	1000PF	J
C530			CC73GCH1H102J	CHIP C	1000PF	J
C531			CE04KW1H220M	ELECTRO	22UF	50WV
C531			CE04KW1H220M	ELECTRO	22UF	50WV
C532			CE04KW1H100M	ELECTRO	10UF	50WV
C532			CE04KW1H100M	ELECTRO	10UF	50WV
C533			CK73GF1C224Z	CHIP C	0.22UF	Z
C533			CK73GF1C224Z	CHIP C	0.22UF	Z
C534			CK73GB1H103K	CHIP C	0.010UF	K
C534			CK73GB1H103K	CHIP C	0.010UF	K
C535,536			CK73GB1H103K	CHIP C	0.010UF	K
C537			CK73GB1H103K	CHIP C	0.010UF	K
C539			CE04KW1A471M	ELECTRO	470UF	10WV
C541			CK73GB1H103K	CHIP C	0.010UF	K
C544			CE04KW1H100M	ELECTRO	10UF	50WV
C601-616			CC73GCH1H101J	CHIP C	100PF	J

L : Scandinavia K : USA P : Canada R : Mexico C : China I : Malaysia
Y : PX(Far East,Hawaii) T : England E : Europe G : Germany V : China(Shanghai)
Y : AAFES(Europe) X : Australia Q : Russia H : Korea M : Other Areas ⚠ indicates safety critical components.

* New Parts
Parts without **Parts No.** are not supplied.
Les articles non mentionnés dans le **Parts No.** ne sont pas fournis.
Teile ohne **Parts No.** werden nicht geliefert.

30

Ref. No	Add-ress	New Parts	Parts No.	Description	Desti-nation	Re-marks
C617-621			CK73GF1E104Z	CHIP C	0.10UF	Z
C622			CE04KW1A471M	ELECTRO	470UF	10WV
C623			CK73GF1E104Z	CHIP C	0.10UF	Z
C624			CE04KW1A101M	ELECTRO	100UF	10WV
C625			CK73GF1E104Z	CHIP C	0.10UF	Z
C626			CE04KW1A471M	ELECTRO	470UF	10WV
C627			CK73GF1E104Z	CHIP C	0.10UF	Z
C628			CE04KW1A101M	ELECTRO	100UF	10WV
C629			CK73GF1E104Z	CHIP C	0.10UF	Z
C630			CE04KW1A101M	ELECTRO	100UF	10WV
C631			CK73GF1E104Z	CHIP C	0.10UF	Z
C632			CE04KW1A101M	ELECTRO	100UF	10WV
C633			CK73GF1E104Z	CHIP C	0.10UF	Z
C634			CE04KW1A101M	ELECTRO	100UF	10WV
C635			CK73GF1E104Z	CHIP C	0.10UF	Z
C636			CE04KW1A471M	ELECTRO	470UF	10WV
C637			CK73GF1E104Z	CHIP C	0.10UF	Z
C638,639			CK73GF1A105Z	CHIP C	1.0UF	Z
C640,641			CE04KW1A101M	ELECTRO	100UF	10WV
C642			CE04KW1H010M	ELECTRO	1.0UF	50WV
C643			CK73GB1H103K	CHIP C	0.010UF	K
C644			CK73GF1E104Z	CHIP C	0.10UF	Z
C645			CE04KW1H100M	ELECTRO	10UF	50WV
C646			CK73GF1H223Z	CHIP C	0.022UF	Z
C647			CK73GB1H103K	CHIP C	0.010UF	K
C648			CK73GF1E104Z	CHIP C	0.10UF	Z
C649,650			CE04KW1E470M	ELECTRO	47UF	25WV
C651,652			CE04KW1A221M	ELECTRO	220UF	10WV
C653			CE04KW1H100M	ELECTRO	10UF	50WV
C654			CK73GB1H182K	CHIP C	1800PF	K
C655			CC73GCH1H102J	CHIP C	1000PF	J
C656			CE04KW1H220M	ELECTRO	22UF	50WV
C657			CE04KW1A221M	ELECTRO	220UF	10WV
C658			CK73GF1A105Z	CHIP C	1.0UF	Z
C659			CK73GB1H103K	CHIP C	0.010UF	K
C670			CK73GF1E104Z	CHIP C	0.10UF	Z
C671			CE04KW1H100M	ELECTRO	10UF	50WV
C672			CE04KW1E470M	ELECTRO	47UF	25WV
C901-903			CE04KW1H010M	ELECTRO	1.0UF	50WV
C904			CE04KW1A221M	ELECTRO	220UF	10WV
C905			CE04KW1H010M	ELECTRO	1.0UF	50WV
C906-909			CC73GCH1H101J	CHIP C	100PF	J
CN1			E40-3257-05	PIN ASSY		
CN2			E40-3256-05	PIN ASSY		
CN3			E40-4297-05	FLAT CABLE CONNECTOR		
CN4			E40-9849-05	PIN ASSY		
CN5,6			E40-9853-05	PIN ASSY		
CN7			E40-9840-05	PIN ASSY		
CN9		*	E40-9852-05	PIN ASSY		
CN10			E40-9853-05	PIN ASSY		
CN11,12		*	E40-9852-05	PIN ASSY		
CN13			E40-8258-05	FLAT CABLE CONNECTOR		
CN14			E40-8255-05	FLAT CABLE CONNECTOR		
CN15			E40-9849-05	PIN ASSY		

L : Scandinavia K : USA P : Canada R : Mexico C : China I : Malaysia
Y : PX(Far East,Hawaii) T : England E : Europe G : Germany V : China(Shanghai)
Y : AAFES(Europe) X : Australia Q : Russia H : Korea M : Other Areas ⚠ indicates safety critical components.

PARTS LIST

KRF-X9995D/X9995D-S/M/R-5700/5900

* New Parts
Parts without **Parts No.** are not supplied.
Les articles non mentionnés dans le **Parts No.** ne sont pas fournis.
Teile ohne **Parts No.** werden nicht geliefert.

31

Ref. No	Add-ress	New Parts	Parts No.	Description	Desti-nation	Re-marks
CN16			E40-4296-05	FLAT CABLE CONNECTOR		
CN501			E40-9836-05	SOCKET FOR PIN ASSY		
CN601		*	E40-9835-05	SOCKET FOR PIN ASSY		
J501_502			E63-1125-05	PIN JACK		
J503			E63-1123-05	PIN JACK		
J601_602			E56-0030-05	CYLINDRICAL RECEPTACLE		
J603			E56-0028-05	CYLINDRICAL RECEPTACLE		
J901			E58-0033-05	RECTANGULAR RECEPTACLE		
△ F5 -7			F06-1022-05	FUSE (SEMKO) (250V T1AL)	E1M1X1	
△ F5 -7			F06-1022-05	FUSE (SEMKO) (250V T1AL)	T1E2	
△ F5 -7			F50-0067-05	FUSE(5X20)	KK1	
△ F8			F05-3121-05	FUSE (SEMKO) (250V T3.15AL)	E1M1X1	
△ F8			F05-3121-05	FUSE (SEMKO) (250V T3.15AL)	T1E2	
△ F8			F50-0072-05	FUSE(5X20)	KK1	
CN22-29			J13-0075-05	FUSE CLIP		
L1 -9			L92-0140-05	CHIP FERRITE		
L10			L92-0140-05	CHIP FERRITE	M1	
L11 -13			L92-0140-05	CHIP FERRITE		
L601			L76-0018-05	DELAY LINE	KK1	
L602			L76-0019-05	DELAY LINE	E1M1X1	
L602			L76-0019-05	DELAY LINE	T1E2	
L603			L79-1262-05	LC FILTER	E1M1X1	
L603			L79-1262-05	LC FILTER	T1E2	
X1			L78-0615-05	RESONATOR (12.5MHZ)		
X2			L78-0674-05	RESONATOR (3.64MHZ)		
X3			L77-2002-05	CRYSTAL RESONATOR(4.332MHZ)	E2	
X3			L77-2002-05	CRYSTAL RESONATOR(4.332MHZ)	K1E1T1	
△ R1			RD14NB2E100J	RD 10 J 1/4W		
R2			RK73GB1J102J	CHIP R 1.0K J 1/16W		
△ R3			RD14NB2E2R2J	RD 2.2 J 1/4W		
R4			RK73GB1J102J	CHIP R 1.0K J 1/16W		
R5			RK73GB1J221J	CHIP R 220 J 1/16W		
R6			RK73GB1J104J	CHIP R 100K J 1/16W		
R7			RK73GB1J102J	CHIP R 1.0K J 1/16W		
R8			RK73GB1J103J	CHIP R 10K J 1/16W		
R9			RK73GB1J102J	CHIP R 1.0K J 1/16W		
R10			RK73GB1J103J	CHIP R 10K J 1/16W		
R11			RK73GB1J101J	CHIP R 100 J 1/16W		
R12			RK73GB1J105J	CHIP R 1.0M J 1/16W		
R13 ,14			RK73GB1J331J	CHIP R 330 J 1/16W		
R15 -18			RK73GB1J104J	CHIP R 100K J 1/16W		
R19			RK73GB1J105J	CHIP R 1.0M J 1/16W		
R21 ,22			RK73GB1J332J	CHIP R 3.3K J 1/16W		
R23 ,24			RK73GB1J103J	CHIP R 10K J 1/16W		
R35			RK73GB1J473J	CHIP R 47K J 1/16W		
R41 ,42			RK73GB1J103J	CHIP R 10K J 1/16W		
R51 ,52			RK73GB1J473J	CHIP R 47K J 1/16W		
R53 ,54			RK73GB1J472J	CHIP R 4.7K J 1/16W		
R56 ,57			RK73GB1J472J	CHIP R 4.7K J 1/16W		
R58 -60			RK73GB1J101J	CHIP R 100 J 1/16W		
R58 -60			RK73GB1J101J	CHIP R 100 J 1/16W	K1E1M1	
R61 -63			RS14KB3A332J	FL-PROOF RS 3.3K J 1W	X1T1E2	
					K1E1M1	

L : Scandinavia K : USA P : Canada R : Mexico C : China I : Malaysia
Y : PX(Far East,Hawaii) T : England E : Europe G : Germany V : China(Shanghai)
Y : AAFES(Europe) X : Australia Q : Russia H : Korea M : Other Areas △ indicates safety critical components .

* New Parts
Parts without **Parts No.** are not supplied.
Les articles non mentionnés dans le **Parts No.** ne sont pas fournis.
Teile ohne **Parts No.** werden nicht geliefert.

32

Ref. No	Add-ress	New Parts	Parts No.	Description	Desti-nation	Re-marks
R61 -63			RS14KB3A332J	FL-PROOF RS 3.3K J 1W	X1T1E2	
R64			RK73GB1J473J	CHIP R 47K J 1/16W		
R69			RK73GB1J473J	CHIP R 47K J 1/16W		
R70 ,71			RK73GB1J332J	CHIP R 3.3K J 1/16W		
R72 ,73			RK73GB1J102J	CHIP R 1.0K J 1/16W		
R74 ,75			RK73GB1J103J	CHIP R 10K J 1/16W		
R76 ,77			RK73GB1J102J	CHIP R 1.0K J 1/16W		
R78 ,79			RK73GB1J104J	CHIP R 100K J 1/16W		
R80 -87			RK73GB1J473J	CHIP R 47K J 1/16W		
R88			RK73GB1J2R2J	CHIP R 2.2 J 1/16W		
R89			RK73GB1J101J	CHIP R 100 J 1/16W		
R90			RK73GB1J104J	CHIP R 100K J 1/16W		
R91 -96			RK73GB1J102J	CHIP R 1.0K J 1/16W		
R97			RK73GB1J2R2J	CHIP R 2.2 J 1/16W		
△ R98			RD14NB2E471J	RD 470 J 1/4W	KK1	
R99			RK73GB1J101J	CHIP R 100 J 1/16W		
R100			RK73GB1J102J	CHIP R 1.0K J 1/16W		
R101			RK73GB1J182J	CHIP R 1.8K J 1/16W	M1X1	
R101			RK73GB1J472J	CHIP R 4.7K J 1/16W	E1T1E2	
R101			RK73GB1J562J	CHIP R 5.6K J 1/16W	K1	
R101			RK73GB1J822J	CHIP R 8.2K J 1/16W	K	
R102			RK73GB1J103J	CHIP R 10K J 1/16W	M1X1	
R102			RK73GB1J332J	CHIP R 3.3K J 1/16W	K	
R102			RK73GB1J472J	CHIP R 4.7K J 1/16W	K1	
R102			RK73GB1J562J	CHIP R 5.6K J 1/16W	E1T1E2	
R103			RK73GB1J103J	CHIP R 10K J 1/16W	M1X1	
R103			RK73GB1J222J	CHIP R 2.2K J 1/16W	E1T1E2	
R103			RK73GB1J472J	CHIP R 4.7K J 1/16W	K1	
R103			RK73GB1J622J	CHIP R 6.2K J 1/16W	K	
R104			RK73GB1J472J	CHIP R 4.7K J 1/16W	K	
R104			RK73GB1J622J	CHIP R 6.2K J 1/16W	K1	
R104			RK73GB1J822J	CHIP R 8.2K J 1/16W	E1T1E2	
R105			RK73GB1J473J	CHIP R 47K J 1/16W	M1	
R107			RK73GB1J272J	CHIP R 2.7K J 1/16W		
R108			RK73GB1J102J	CHIP R 1.0K J 1/16W		
R109			RD14NB2E101J	RD 100 J 1/4W		
R110			RD14NB2E560J	RD 56 J 1/4W		
R111 ,112			RD14NB2E4R7J	RD 4.7 J 1/4W		
R113			RK73GB1J332J	CHIP R 3.3K J 1/16W		
R114			RK73GB1J272J	CHIP R 2.7K J 1/16W		
R115			RD14NB2E122J	RD 1.2K J 1/4W		
R116			RK73GB1J683J	CHIP R 68K J 1/16W		
R117			RK73GB1J102J	CHIP R 1.0K J 1/16W		
R118			RK73GB1J683J	CHIP R 68K J 1/16W		
R119			RK73GB1J332J	CHIP R 3.3K J 1/16W		
R120			RK73GB1J683J	CHIP R 68K J 1/16W		
R121			RK73GB1J332J	CHIP R 3.3K J 1/16W		
R122			RK73GB1J683J	CHIP R 68K J 1/16W		
R123			RK73GB1J332J	CHIP R 3.3K J 1/16W		
R124			RK73GB1J683J	CHIP R 68K J 1/16W		
R125			RK73GB1J272J	CHIP R 2.7K J 1/16W		
R126			RK73GB1J103J	CHIP R 10K J 1/16W		
△ R127			RD14NB2E100J	RD 10 J 1/4W		
△ R128			RS14KB3D4R7J	FL-PROOF RS 4.7 J 2W		
R130-132			RK73GB1J101J	CHIP R 100 J 1/16W		

L : Scandinavia K : USA P : Canada R : Mexico C : China I : Malaysia
Y : PX(Far East,Hawaii) T : England E : Europe G : Germany V : China(Shanghai)
Y : AAFES(Europe) X : Australia Q : Russia H : Korea M : Other Areas △ indicates safety critical components .

PARTS LIST

KRF-X9995D/X9995D-S/VR-5700/5900

* New Parts
Parts without **Parts No.** are not supplied.
Les articles non mentionnés dans le **Parts No.** ne sont pas fournis.
Teile ohne **Parts No.** werden nicht geliefert.



Ref. No	Add-ress	New Parts	Parts No.	Description	Desti-nation	Re-marks
R133			RK73GB1J332J	CHIP R 3.3K J 1/16W		
R134			RK73GB1J473J	CHIP R 47K J 1/16W		
R135,136			RK73GB1J101J	CHIP R 100 J 1/16W		
R137,138			RK73GB1J332J	CHIP R 3.3K J 1/16W		
R139			RK73GB1J101J	CHIP R 100 J 1/16W		
R140,141			RK73GB1J332J	CHIP R 3.3K J 1/16W	E1T1E2	
R142			RK73GB1J101J	CHIP R 100 J 1/16W		
R150-161			RK73GB1J101J	CHIP R 100 J 1/16W		
R170			RK73GB1J103J	CHIP R 10K J 1/16W	E2	
R170			RK73GB1J103J	CHIP R 10K J 1/16W	K1E1T1	
R171-173			RK73GB1J101J	CHIP R 100 J 1/16W	KK1	
R174,175			RK73GB1J101J	CHIP R 100 J 1/16W		
R176-178			RK73GB1J101J	CHIP R 100 J 1/16W	E1T1E2	
R176-178			RK73GB1J101J	CHIP R 100 J 1/16W	K1	
R179,180			RK73GB1J101J	CHIP R 100 J 1/16W		
R181-192			RK73GB1J102J	CHIP R 1.0K J 1/16W		
R197			RD14NB2E560J	RD 56 J 1/4W		
R198			RK73GB1J472J	CHIP R 4.7K J 1/16W		
R199			RK73GB1J101J	CHIP R 100 J 1/16W		
R200			RK73GB1J221J	CHIP R 220 J 1/16W		
R201			RK73GB1J101J	CHIP R 100 J 1/16W		
R202,203			RK73GB1J103J	CHIP R 10K J 1/16W		
R204-208			RK73GB1J101J	CHIP R 100 J 1/16W		
R209			RK73GB1J105J	CHIP R 1.0M J 1/16W		
R212,213			RK73GB1J102J	CHIP R 1.0K J 1/16W		
R214,215			RK73GB1J104J	CHIP R 100K J 1/16W		
R216			RK73GB1J105J	CHIP R 1.0M J 1/16W		
R223,224			RK73GB1J103J	CHIP R 10K J 1/16W		
R229			RK73GB1J101J	CHIP R 100 J 1/16W		
R230			RK73GB1J220J	CHIP R 22 J 1/16W	E2	
R230			RK73GB1J220J	CHIP R 22 J 1/16W	K1E1T1	
R231,232			RK73GB1J102J	CHIP R 1.0K J 1/16W	E2	
R231,232			RK73GB1J102J	CHIP R 1.0K J 1/16W	K1E1T1	
R233			RK73GB1J103J	CHIP R 10K J 1/16W	E2	
R233			RK73GB1J103J	CHIP R 10K J 1/16W	K1E1T1	
R234			RK73GB1J221J	CHIP R 220 J 1/16W	E2	
R234			RK73GB1J221J	CHIP R 220 J 1/16W	K1E1T1	
R235,236			RK73GB1J105J	CHIP R 1.0M J 1/16W	E2	
R235,236			RK73GB1J105J	CHIP R 1.0M J 1/16W	K1E1T1	
R251-256			RK73GB1J472J	CHIP R 4.7K J 1/16W		
R257			RK73GB1J332J	CHIP R 3.3K J 1/16W		
R258,259			RK73GB1J272J	CHIP R 2.7K J 1/16W		
R264-266			RK73GB1J103J	CHIP R 10K J 1/16W		
R301-303			RK73GB1J391J	CHIP R 390 J 1/16W		
R304-306			RK73GB1J101J	CHIP R 100 J 1/16W		
R307,308			RK73GB1J222J	CHIP R 2.2K J 1/16W		
R309			RK73GB1J474J	CHIP R 470K J 1/16W		
R310			RK73GB1J163J	CHIP R 16K J 1/16W		
R311			RK73GB1J153J	CHIP R 15K J 1/16W		
R312			RK73GB1J470J	CHIP R 47 J 1/16W		
R313-315			RK73GB1J2R2J	CHIP R 2.2 J 1/16W		
R316			RK73GB1J103J	CHIP R 10K J 1/16W		
R317			RK73GB1J472J	CHIP R 4.7K J 1/16W		
R318			RK73GB1J104J	CHIP R 100K J 1/16W		
R321,322			RK73GB1J471J	CHIP R 470 J 1/16W		

L : Scandinavia K : USA P : Canada R : Mexico C : China I : Malaysia
Y : PX(Far East,Hawaii) T : England E : Europe G : Germany V : China(Shanghai)
Y : AAFES(Europe) X : Australia Q : Russia H : Korea M : Other Areas Δ indicates safety critical components .

* New Parts
Parts without **Parts No.** are not supplied.
Les articles non mentionnés dans le **Parts No.** ne sont pas fournis.
Teile ohne **Parts No.** werden nicht geliefert.



Ref. No	Add-ress	New Parts	Parts No.	Description	Desti-nation	Re-marks
R324			RK73GB1J471J	CHIP R 470 J 1/16W		
R325			RK73GB1J102J	CHIP R 1.0K J 1/16W		
R326,327			RK73GB1J2R2J	CHIP R 2.2 J 1/16W		
R329			RK73GB1J102J	CHIP R 1.0K J 1/16W		
R330			RK73GB1J471J	CHIP R 470 J 1/16W		
R331			RD14NB2E332J	RD 3.3K J 1/4W		
R332			RK73GB1J221J	CHIP R 220 J 1/16W		
R333			RD14NB2E2R2J	RD 2.2 J 1/4W		
R334			RK73GB1J101J	CHIP R 100 J 1/16W		
R341-346			RD14NB2E1R0J	RD 1 J 1/4W		
R350-361			RK73GB1J473J	CHIP R 47K J 1/16W		
R370-372			RK73GB1J4R7J	CHIP R 4.7 J 1/16W		
R400			RK73GB1J473J	CHIP R 47K J 1/16W		
R401,402			RK73GB1J101J	CHIP R 100 J 1/16W		
R403			RK73GB1J102J	CHIP R 1.0K J 1/16W		
R410,411			RD14NB2E4R7J	RD 4.7 J 1/4W		
R501			RK73GB1J104J	CHIP R 100K J 1/16W		
R502			RK73FB2A750J	CHIP R 75 J 1/10W		
R503			RK73GB1J104J	CHIP R 100K J 1/16W		
R504-507			RK73FB2A750J	CHIP R 75 J 1/10W		
R508			RK73GB1J104J	CHIP R 100K J 1/16W		
R509			RK73FB2A680J	CHIP R 68 J 1/10W		
R510			RK73GB1J104J	CHIP R 100K J 1/16W		
R511			RK73FB2A680J	CHIP R 68 J 1/10W		
R512			RK73GB1J104J	CHIP R 100K J 1/16W		
R513			RK73FB2A680J	CHIP R 68 J 1/10W		
R514,515			RK73GB1J103J	CHIP R 10K J 1/16W		
R516			RD14NB2E4R7J	RD 4.7 J 1/4W		
R517			RK73GB1J562J	CHIP R 5.6K J 1/16W	K1E1M1	
R517			RK73GB1J562J	CHIP R 5.6K J 1/16W	X1T1E2	
R518			RK73GB1J103J	CHIP R 10K J 1/16W	K1E1M1	
R518			RK73GB1J103J	CHIP R 10K J 1/16W	X1T1E2	
R519			RK73GB1J223J	CHIP R 22K J 1/16W	K1E1M1	
R519			RK73GB1J223J	CHIP R 22K J 1/16W	X1T1E2	
R520			RK73GB1J103J	CHIP R 10K J 1/16W	K1E1M1	
R520			RK73GB1J103J	CHIP R 10K J 1/16W	X1T1E2	
R521			RK73GB1J104J	CHIP R 100K J 1/16W	K1E1M1	
R521			RK73GB1J104J	CHIP R 100K J 1/16W	X1T1E2	
R522			RK73GB1J101J	CHIP R 100 J 1/16W	K1E1M1	
R522			RK73GB1J101J	CHIP R 100 J 1/16W	X1T1E2	
R523			RK73GB1J474J	CHIP R 470K J 1/16W	K1E1M1	
R523			RK73GB1J474J	CHIP R 470K J 1/16W	X1T1E2	
R524			RK73GB1J153J	CHIP R 15K J 1/16W	K1E1M1	
R524			RK73GB1J153J	CHIP R 15K J 1/16W	X1T1E2	
R525,526			RK73GB1J103J	CHIP R 10K J 1/16W	K1E1M1	
R525,526			RK73GB1J103J	CHIP R 10K J 1/16W	X1T1E2	
R527			RK73GB1J222J	CHIP R 2.2K J 1/16W	K1E1M1	
R527			RK73GB1J222J	CHIP R 2.2K J 1/16W	X1T1E2	
R528			RK73GB1J103J	CHIP R 10K J 1/16W	K1E1M1	
R528			RK73GB1J103J	CHIP R 10K J 1/16W	X1T1E2	
R529,530			RK73GB1J473J	CHIP R 47K J 1/16W		
R531-533			RK73GB1J1R0J	CHIP R 1 J 1/16W		
R534,535			RK73GB1J1R0J	CHIP R 1 J 1/16W	K1E1M1	
R534,535			RK73GB1J1R0J	CHIP R 1 J 1/16W	X1T1E2	
R536			RK73FB2A680J	CHIP R 68 J 1/10W		

L : Scandinavia K : USA P : Canada R : Mexico C : China I : Malaysia
Y : PX(Far East,Hawaii) T : England E : Europe G : Germany V : China(Shanghai)
Y : AAFES(Europe) X : Australia Q : Russia H : Korea M : Other Areas Δ indicates safety critical components .

* New Parts

Parts without **Parts No.** are not supplied.

Les articles non mentionnés dans le **Parts No.** ne sont pas fournis.

Teile ohne **Parts No.** werden nicht geliefert.



Ref. No	Add-ress	New Parts	Parts No.	Description	Desti-nation	Re-marks
R539			RK73GB1J103J	CHIP R 10K J 1/16W		
R540			RK73GB1J473J	CHIP R 47K J 1/16W		
R541			RK73GB1J104J	CHIP R 100K J 1/16W		
R542			RK73GB1J102J	CHIP R 1.0K J 1/16W		
R543			RK73GB1J473J	CHIP R 47K J 1/16W		
R551-560			RK73GB1J101J	CHIP R 100 J 1/16W		
R563			RK73GB1J104J	CHIP R 100K J 1/16W		
R601,602			RK73GB1J104J	CHIP R 100K J 1/16W		
R603			RK73FB2A750J	CHIP R 75 J 1/10W		
R604,605			RK73GB1J104J	CHIP R 100K J 1/16W		
R606-609			RK73FB2A750J	CHIP R 75 J 1/10W		
R610,611			RK73GB1J104J	CHIP R 100K J 1/16W		
R612-616			RK73FB2A750J	CHIP R 75 J 1/10W		
R617			RK73GB1J104J	CHIP R 100K J 1/16W		
R618,619			RK73FB2A680J	CHIP R 68 J 1/10W		
R620,621			RK73GB1J104J	CHIP R 100K J 1/16W		
R622,623			RK73FB2A680J	CHIP R 68 J 1/10W		
R624			RK73GB1J104J	CHIP R 100K J 1/16W		
R625,626			RK73FB2A680J	CHIP R 68 J 1/10W		
R627-630			RK73GB1J103J	CHIP R 10K J 1/16W		
R631,632			RK73GB1J473J	CHIP R 47K J 1/16W		
R633-635			RK73GB1J1R0J	CHIP R 1 J 1/16W		
R636			RK73GB1J103J	CHIP R 10K J 1/16W		
R637			RK73GB1J273J	CHIP R 27K J 1/16W		
R638			RK73GB1J332J	CHIP R 3.3K J 1/16W		
R639,640			RK73GB1J102J	CHIP R 1.0K J 1/16W		
R641,642			RK73GB1J1R0J	CHIP R 1 J 1/16W		
R643,644			RK73GB1J151J	CHIP R 150 J 1/16W		
R645			RK73GB1J473J	CHIP R 47K J 1/16W		
R647			RK73GB1J103J	CHIP R 10K J 1/16W		
R648			RK73GB1J223J	CHIP R 22K J 1/16W		
R649,650			RK73GB1J103J	CHIP R 10K J 1/16W		
R651			RK73GB1J562J	CHIP R 5.6K J 1/16W		
R652			RK73GB1J104J	CHIP R 100K J 1/16W		
R653			RK73GB1J101J	CHIP R 100 J 1/16W		
R654			RK73GB1J474J	CHIP R 470K J 1/16W		
R655			RK73GB1J103J	CHIP R 10K J 1/16W		
R659-662			RK73GB1J911J	CHIP R 910 J 1/16W		
R663			RK73GB1J183J	CHIP R 18K J 1/16W		
R665			RK73GB1J103J	CHIP R 10K J 1/16W		
R666			RK73GB1J273J	CHIP R 27K J 1/16W		
R667			RK73GB1J332J	CHIP R 3.3K J 1/16W		
R668			RK73GB1J104J	CHIP R 100K J 1/16W		
R669,670			RK73GB1J471J	CHIP R 470 J 1/16W		
R674			RK73GB1J1R0J	CHIP R 1 J 1/16W		
R687			RK73GB1J1R0J	CHIP R 1 J 1/16W		
R830			RK73GB1J1R0J	CHIP R 1 J 1/16W		
R901-908			RK73GB1J101J	CHIP R 100 J 1/16W		
R909			RK73GB1J220J	CHIP R 22 J 1/16W		
W501,502			R92-1963-05	JUMPER WIRE (RESISTOR TYPE)		
D1			U1BC44	DIODE		
D2			MA111	DIODE		
D3			U1BC44	DIODE		
D4 -6			MA111	DIODE		
D7			DAN202U	DIODE		

L : Scandinavia K : USA P : Canada R : Mexico C : China I : Malaysia

Y : PX(Far East,Hawaii) T : England E : Europe G : Germany V : China(Shanghai)

Y : AAFES(Europe) X : Australia Q : Russia H : Korea M : Other Areas Δ indicates safety critical components .

* New Parts

Parts without **Parts No.** are not supplied.

Les articles non mentionnés dans le **Parts No.** ne sont pas fournis.

Teile ohne **Parts No.** werden nicht geliefert.



Ref. No	Add-ress	New Parts	Parts No.	Description	Desti-nation	Re-marks
D7			1SS301	DIODE		
D8			DAP202U	DIODE		
D8			1SS300	DIODE		
D9			DAN202U	DIODE		
D9			1SS301	DIODE		
D10			DAP202U	DIODE		
D10			1SS300	DIODE		
D11 -23			MA111	DIODE		
D27 -29			U1BC44	DIODE		
D30			UDZS5.6B	ZENER DIODE		
D30			UDZ5.6B	ZENER DIODE		
D35			DAN202U	DIODE		
D35			1SS301	DIODE		
D36 ,37			MA111	DIODE		
D38			DAN202U	DIODE		
D38			1SS301	DIODE		
D41 ,42			DAP202U	DIODE		
D41 ,42			1SS300	DIODE		
D43 -45			MA111	DIODE		
Δ D51			S1ZB20(4072)	DIODE		
D52			UDZS8.2B	ZENER DIODE		
D52			UDZ8.2B	ZENER DIODE		
D53		*	UDZS7.5B	ZENER DIODE		
D53			UDZ7.5B	ZENER DIODE		
Δ D61			D4SBL20UF03	DIODE		
D62			UDZS6.2B	ZENER DIODE		
D62			UDZ6.2B	ZENER DIODE		
D63			MA111	DIODE		
Δ D71			KBP02ML-6127	DIODE		
D72			UDZ16B	ZENER DIODE		
D80 ,81			DA204U	DIODE		
D80 ,81			1SS302	DIODE		
D501			DAN202U	DIODE		
D501			1SS301	DIODE		
D502			DAP202U	DIODE		
D502			1SS300	DIODE		
D503,504			MA111	DIODE		
D505			DA204U	DIODE		K1E1M1
D505			DA204U	DIODE		X1T1E2
D505			DA204U	DIODE		K1E1M1
D505			1SS302	DIODE		
D505			1SS302	DIODE		X1T1E2
D601			DAN202U	DIODE		
D601			1SS301	DIODE		
D602			DAP202U	DIODE		
D602			1SS300	DIODE		
D603,604			MA111	DIODE		
D605			DA204U	DIODE		
D605			1SS302	DIODE		
IC1			TA78057S	ANALOGUE IC		
IC2			S-80740AL-A4	IC(VOLTAGE DETECTOR)		
IC2		*	S-80840ALUP	MOS-IC		
IC3		*	UPD784217A516	MI-COM IC		
IC4			TC74HCT7007AF	MOS-IC		
IC5			TC74HC164AF	IC(SHIFT REGISTER)		
IC6			UPD17215GT-737	MI-COM IC		

L : Scandinavia K : USA P : Canada R : Mexico C : China I : Malaysia

Y : PX(Far East,Hawaii) T : England E : Europe G : Germany V : China(Shanghai)

Y : AAFES(Europe) X : Australia Q : Russia H : Korea M : Other Areas Δ indicates safety critical components .

PARTS LIST

KRF-X9995D/X9995D-S/VR-5700/5900

* New Parts
Parts without **Parts No.** are not supplied.
Les articles non mentionnés dans le **Parts No.** ne sont pas fournis.
Teile ohne **Parts No.** werden nicht geliefert.

37

Ref. No	Add-ress	New Parts	Parts No.	Description	Desti-nation	Re-marks
IC7			LC72723M	MOS-IC	E2	
IC7			LC72723M	MOS-IC	K1E1T1	
IC501		*	MM1140XFF	ANALOGUE IC		
IC502			BA7611AF	ANALOGUE IC		
IC503			BA7623F	ANALOGUE IC		
IC504			BA7649AF	ANALOGUE IC		
IC505			BA7649AF	ANALOGUE IC	K1E1M1	
IC505			BA7649AF	ANALOGUE IC	X1T1E2	
IC506			NJM4565M	ANALOGUE IC	K1E1M1	
IC506			NJM4565M	ANALOGUE IC	X1T1E2	
IC507		*	MM1508	ANALOGUE IC		
IC601,602		*	MM1140XFF	ANALOGUE IC		
IC603			BA7611AF	ANALOGUE IC		
IC604			BA7612F	ANALOGUE IC		
IC605,606			BA7623F	ANALOGUE IC		
IC607			NJM4565M	ANALOGUE IC		
IC608			UPC29M05HB	ANALOGUE IC		
IC901			MAX232NS	MOS-IC		
Q1			2SC4081(R,S)	TRANSISTOR		
Q1			2SC4116(Y,GR)	TRANSISTOR		
Q2			DTC124EUA	DIGITAL TRANSISTOR	M1	
Q2			UN5212	DIGITAL TRANSISTOR	M1	
Q3			DTA113ZUA	DIGITAL TRANSISTOR		
Q3			UN5119	DIGITAL TRANSISTOR		
Q4			DTC143TUA	DIGITAL TRANSISTOR		
Q4			UN5216	DIGITAL TRANSISTOR		
Q5			DTA113ZUA	DIGITAL TRANSISTOR		
Q5			UN5119	DIGITAL TRANSISTOR		
Q6			DTC143TUA	DIGITAL TRANSISTOR		
Q6			UN5216	DIGITAL TRANSISTOR		
Q7			DTA113ZUA	DIGITAL TRANSISTOR		
Q7			UN5119	DIGITAL TRANSISTOR		
Q8			DTC143TUA	DIGITAL TRANSISTOR		
Q8			UN5216	DIGITAL TRANSISTOR		
Q9			DTA113ZUA	DIGITAL TRANSISTOR		
Q9			UN5119	DIGITAL TRANSISTOR		
Q10			DTC143TUA	DIGITAL TRANSISTOR		
Q10			UN5216	DIGITAL TRANSISTOR		
Q11			DTA113ZUA	DIGITAL TRANSISTOR		
Q11			UN5119	DIGITAL TRANSISTOR		
Q12			DTC143TUA	DIGITAL TRANSISTOR		
Q12			UN5216	DIGITAL TRANSISTOR		
Q13			DTA113ZUA	DIGITAL TRANSISTOR		
Q13			UN5119	DIGITAL TRANSISTOR		
Q14			DTC143TUA	DIGITAL TRANSISTOR		
Q14			UN5216	DIGITAL TRANSISTOR		
Q15			DTA143TUA	DIGITAL TRANSISTOR		
Q15			UN5116	DIGITAL TRANSISTOR		
Q16			DTC124EUA	DIGITAL TRANSISTOR		
Q16			UN5212	DIGITAL TRANSISTOR		
Q17			2SC3940A(R,S)	TRANSISTOR		
Q18			DTA143TUA	DIGITAL TRANSISTOR		
Q18			UN5116	DIGITAL TRANSISTOR		
Q19			2SC4213(B)	TRANSISTOR		
Q31 ,32			2SK246(Y,GR)	FET		

L : Scandinavia K : USA P : Canada R : Mexico C : China I : Malaysia
Y : PX(Far East,Hawaii) T : England E : Europe G : Germany V : China(Shanghai)
Y : AAFES(Europe) X : Australia Q : Russia H : Korea M : Other Areas Δ indicates safety critical components .

* New Parts
Parts without **Parts No.** are not supplied.
Les articles non mentionnés dans le **Parts No.** ne sont pas fournis.
Teile ohne **Parts No.** werden nicht geliefert.

38

Ref. No	Add-ress	New Parts	Parts No.	Description	Desti-nation	Re-marks
Δ Q33 ,34			2SB1375	TRANSISTOR		
Δ Q35			2SC4081(R,S)	TRANSISTOR		
Δ Q35			2SC4116(Y,GR)	TRANSISTOR		
Δ Q36			2SA1576A(R,S)	TRANSISTOR		
Δ Q36			2SA1586(Y,GR)	TRANSISTOR		
Q37			2SC4081(R,S)	TRANSISTOR		
Q37			2SC4116(Y,GR)	TRANSISTOR		
Q38			2SA1576A(R,S)	TRANSISTOR		
Q38			2SA1586(Y,GR)	TRANSISTOR		
Δ Q41 ,42			2SB1375	TRANSISTOR		
Δ Q43			2SC4081(R,S)	TRANSISTOR		
Δ Q43			2SC4116(Y,GR)	TRANSISTOR		
Δ Q45			2SB1375	TRANSISTOR		
Δ Q46			2SC4081(R,S)	TRANSISTOR		
Δ Q46			2SC4116(Y,GR)	TRANSISTOR		
Δ Q51			2SD2012	TRANSISTOR		
Δ Q52			2SC4081(R,S)	TRANSISTOR		
Δ Q52			2SC4116(Y,GR)	TRANSISTOR		
Q61			DTC124EUA	DIGITAL TRANSISTOR		
Q61			UN5212	DIGITAL TRANSISTOR		
Q62			DTA143TUA	DIGITAL TRANSISTOR		
Q62			UN5116	DIGITAL TRANSISTOR		
Q501,502			2SC4213(B)	TRANSISTOR		
Q503			2SC4081(R,S)	TRANSISTOR	K1E1M1	
Q503			2SC4081(R,S)	TRANSISTOR	X1T1E2	
Q503			2SC4116(Y,GR)	TRANSISTOR	K1E1M1	
Q503			2SC4116(Y,GR)	TRANSISTOR	X1T1E2	
Q504,505			DTA124EUA	DIGITAL TRANSISTOR		
Q504,505			UN5112	DIGITAL TRANSISTOR		
Q506			DTC124EUA	DIGITAL TRANSISTOR		
Q506			UN5212	DIGITAL TRANSISTOR		
Q508,509			2SC4213(B)	TRANSISTOR		
Q601-604			2SC4213(B)	TRANSISTOR		
Q605,606			DTA124EUA	DIGITAL TRANSISTOR		
Q605,606			UN5112	DIGITAL TRANSISTOR		
Q607			DTC124EUA	DIGITAL TRANSISTOR		
Q607			UN5212	DIGITAL TRANSISTOR		
Q608,609			DTA124EUA	DIGITAL TRANSISTOR		
Q608,609			UN5112	DIGITAL TRANSISTOR		
Q610,611			DTC124EUA	DIGITAL TRANSISTOR		
Q610,611			UN5212	DIGITAL TRANSISTOR		
Q613,614			2SC4213(B)	TRANSISTOR		
DISPLAY (X25-6410-12)						
D3 -10			B30-2532-05	LED(INFRARED)		
D11			B30-2548-05	LED(GRN5,HI BRT)	K	
D11			B30-2571-05	LED(BLUE)	K1E1M1	
D11			B30-2571-05	LED(BLUE)	X1T1E2	
D12			B30-2430-05	LED(RED)		
D15 -18			B30-2571-05	LED(BLUE)	K1E1M1	
D15 -18			B30-2571-05	LED(BLUE)	X1T1E2	
D15 -18			B30-2573-05	LED(RED5,HI BRT)	K	
D19 -23			B30-2430-05	LED(RED)		
D24 ,25			B30-2571-05	LED(BLUE)	K1E1M1	
D24 ,25			B30-2571-05	LED(BLUE)	X1T1E2	

L : Scandinavia K : USA P : Canada R : Mexico C : China I : Malaysia
Y : PX(Far East,Hawaii) T : England E : Europe G : Germany V : China(Shanghai)
Y : AAFES(Europe) X : Australia Q : Russia H : Korea M : Other Areas Δ indicates safety critical components .

* New Parts
Parts without **Parts No.** are not supplied.
Les articles non mentionnés dans le **Parts No.** ne sont pas fournis.
Teile ohne **Parts No.** werden nicht geliefert.



Ref. No	Add-ress	New Parts	Parts No.	Description	Desti-nation	Re-marks
D24 ,25 D26 D30 ,31		*	B30-2573-05 B30-2597-05 B30-2430-05	LED(RED5,HI BRT) LED(RED HI-BRIGHT) LED(RED)	K	
C1 ,2 C3 C4 C5 C6			CE04RW1C101M CC73GCH1H102J CC73GCH1H101J CE04KW1H100M CK73GB1H103K	ELECTRO CHIP C CHIP C ELECTRO CHIP C	100UF 1000PF 100PF 10UF 0.010UF	16WV J J 50WV K
C7 -22 C23 C24 C25 -27 C28			CC73GCH1H221J CE04KW1H100M CC73GCH1H471J CC73GCH1H101J CE04KW1E470M	CHIP C ELECTRO CHIP C CHIP C ELECTRO	220PF 10UF 470PF 100PF 47UF	J 50WV J J 25WV
C29 C29 C30 C30 C31			CE04RW1A101M CE04RW1A101M CK73GB1H103K CK73GB1H103K CE04KW1H101M	ELECTRO ELECTRO CHIP C CHIP C ELECTRO	100UF 100UF 0.010UF 0.010UF 100UF	10WV 10WV K K 50WV
C33 C40 C41 -43 C44 ,45 C78 -85			CK73GF1E104Z CQ93FMG1H102J CQ93FMG1H472J CC73GCH1H221J CE04KW1E470M	CHIP C MYLAR MYLAR CHIP C ELECTRO	0.10UF 1000PF 4700PF 220PF 47UF	Z J J J 25WV
C86 C88 C91 -93 C94 C95 -97			CK73GF1E104Z CC73GCH1H270J CC73GCH1H101J CK73GF1E104Z CC73GCH1H101J	CHIP C CHIP C CHIP C CHIP C CHIP C	0.10UF 27PF 100PF 0.10UF 100PF	Z J J Z J
C105 C165,166 C170 C301,302 C303,304			CC73GCH1H101J CK73FF1C105Z CK73GB1H103K CE04KW1H220M CC73GCH1H101J	CHIP C CHIP C CHIP C ELECTRO CHIP C	100PF 1.0UF 0.010UF 22UF 100PF	J Z K 50WV J
C311,312 C313,314 C321,322 C323,324 C331,332			CE04KW1H220M CC73GCH1H101J CE04KW1H220M CC73GCH1H101J CE04KW1H220M	ELECTRO CHIP C ELECTRO CHIP C ELECTRO	22UF 100PF 22UF 100PF 22UF	50WV J 50WV J 50WV
C333,334 C341,342 C343,344 C380 C401,402			CC73GCH1H101J CE04KW1H220M CC73GCH1H101J CC73GCH1H101J CC73GCH1H221J	CHIP C ELECTRO CHIP C CHIP C CHIP C	100PF 22UF 100PF 100PF 220PF	J 50WV J J J
C404,405 C406 C406 C407 C407			CC73GCH1H221J CC73GCH1H101J CC73GCH1H101J CK73GF1E104Z CK73GF1E104Z	CHIP C CHIP C CHIP C CHIP C CHIP C	220PF 100PF 100PF 0.10UF 0.10UF	J J J Z Z
C410 C411,412 C411,412 C413,414 C413,414			CE04KW1A101M CC73GCH1H102J CC73GCH1H102J CK73GF1E104Z CK73GF1E104Z	ELECTRO CHIP C CHIP C CHIP C CHIP C	100UF 1000PF 1000PF 0.10UF 0.10UF	10WV J J Z Z
C415			CC73GCH1H101J	CHIP C		J KK1E1

L : Scandinavia K : USA P : Canada R : Mexico C : China I : Malaysia
Y : PX(Far East,Hawaii) T : England E : Europe G : Germany V : China(Shanghai)
Y : AAFES(Europe) X : Australia Q : Russia H : Korea M : Other Areas Δ indicates safety critical components .

* New Parts
Parts without **Parts No.** are not supplied.
Les articles non mentionnés dans le **Parts No.** ne sont pas fournis.
Teile ohne **Parts No.** werden nicht geliefert.



Ref. No	Add-ress	New Parts	Parts No.	Description	Desti-nation	Re-marks
C415 C416 C416 C417 C417			CC73GCH1H101J CC73GCH1H331J CC73GCH1H331J CC73GCH1H102J CC73GCH1H102J	CHIP C CHIP C CHIP C CHIP C CHIP C	100PF 330PF 330PF 1000PF 1000PF	J J J J J
C419-421 C419-421 C430,431 C430,431			CC73GCH1H101J CC73GCH1H101J CK73GF1E104Z CK73GF1E104Z	CHIP C CHIP C CHIP C CHIP C	100PF 100PF 0.10UF 0.10UF	J J Z Z
CN1 CN1 CN2 CN4 CN5		*	E40-3264-05 E40-3264-05 E40-8794-05 E40-9823-05 E40-8622-05	PIN ASSY PIN ASSY PIN ASSY SOCKET FOR PIN ASSY PIN ASSY		K1E1M1 X1T1E2 E1M1X1
CN5 CN101 CN102 CN103 J1		*	E40-8622-05 E40-8257-05 E40-8254-05 E40-8531-05 E70-0133-05	PIN ASSY FLAT CABLE CONNECTOR FLAT CABLE CONNECTOR FLAT CABLE CONNECTOR SCREW TERMINAL BOARD		T1E2 KK1
J5 J6 J7 J101 J102		*	E63-1121-05 E56-0026-05 E11-0190-05 E63-1176-05 E63-1177-05	PIN JACK CYLINDRICAL RECEPTACLE PHONE JACK (3P) PIN JACK PIN JACK		
J103 J201 J202 J203,204 J203,204		*	E63-1179-05 E11-0907-05 E11-0347-05 E11-0905-05 E11-0905-05	PIN JACK MINIATURE PHONE JACK(2.5MM 1P) MINIATURE PHONE JACK(2P) MINIATURE PHONE JACK(3.5MM 1P) MINIATURE PHONE JACK(3.5MM 1P)		KK1E1 T1E2
J205,206 J205,206 J207-208 J209 J209			E11-0905-05 E11-0905-05 E11-0905-05 E11-0291-05 E11-0291-05	MINIATURE PHONE JACK(3.5MM 1P) MINIATURE PHONE JACK(3.5MM 1P) MINIATURE PHONE JACK(3.5MM 1P) MINIATURE PHONE JACK(2P) MINIATURE PHONE JACK(2P)		E2 K1E1T1 KK1E1 KK1E1 T1E2
E1 E3 ,4			J19-6056-04 J11-0809-05	HOLDER WIRE CLAMPER		
L401 L401 L403,404 L403,404 X1			L40-1011-17 L40-1011-17 L40-1011-17 L40-1011-17 L78-0284-05	SMALL FIXED INDUCTOR(100UH,K) SMALL FIXED INDUCTOR(100UH,K) SMALL FIXED INDUCTOR(100UH,K) SMALL FIXED INDUCTOR(100UH,K) RESONATOR (5MHZ)		KK1E1 T1E2 KK1E1 T1E2
Δ R1 R4 ,5 R6 R6 R6			RD14NB2E4R7J RS14KB3A3R9J RK73GB1J151J RK73GB1J221J RK73GB1J221J	RD FL-PROOF RS CHIP R CHIP R CHIP R	4.7 3.9 150 220 220	J 1/4W J 1W J 1/16W J 1/16W J 1/16W
R7 R9 R10 -12 R14 -16 R17 -67		Δ	RK73GB1J301J RD14NB2E100J RK73GB1J473J RK73GB1J473J RK73GB1J474J	CHIP R RD CHIP R CHIP R CHIP R	300 10 47K 47K 470K	J 1/16W J 1/4W J 1/16W J 1/16W J 1/16W
R68 R69 ,70 R71			RK73GB1J332J RK73GB1J473J RK73GB1J105J	CHIP R CHIP R CHIP R	3.3K 47K 1.0M	J 1/16W J 1/16W J 1/16W

L : Scandinavia K : USA P : Canada R : Mexico C : China I : Malaysia
Y : PX(Far East,Hawaii) T : England E : Europe G : Germany V : China(Shanghai)
Y : AAFES(Europe) X : Australia Q : Russia H : Korea M : Other Areas Δ indicates safety critical components .

PARTS LIST

KRF-X9995D/X9995D-S/VR-5700/5900

* New Parts
Parts without **Parts No.** are not supplied.
Les articles non mentionnés dans le **Parts No.** ne sont pas fournis.
Teile ohne **Parts No.** werden nicht geliefert.



Ref. No	Add-ress	New Parts	Parts No.	Description	Desti-nation	Re-marks
R72 -74			RK73GB1J473J	CHIP R 47K J 1/16W		
R75			RK73GB1J333J	CHIP R 33K J 1/16W		
R79			RS14KB3A390J	FL-PROOF RS 39 J 1W		
R81			RK73GB1J100J	CHIP R 10 J 1/16W		
R82 -85			RK73GB1J221J	CHIP R 220 J 1/16W	K1E1M1	
R82 -85			RK73GB1J221J	CHIP R 220 J 1/16W	X1T1E2	
R82 -85			RK73GB1J271J	CHIP R 270 J 1/16W	K	
R86 -90			RK73GB1J301J	CHIP R 300 J 1/16W		
R91 .92			RK73GB1J221J	CHIP R 220 J 1/16W	K1E1M1	
R91 .92			RK73GB1J221J	CHIP R 220 J 1/16W	X1T1E2	
R91 .92			RK73GB1J271J	CHIP R 270 J 1/16W	K	
R93 -106			RK73GB1J103J	CHIP R 10K J 1/16W		
R107			RD14NB2E100J	RD 10 J 1/4W	K1E1M1	
R107			RD14NB2E100J	RD 10 J 1/4W	X1T1E2	
R109			RK73GB1J101J	CHIP R 100 J 1/16W		
R109			RK73GB1J101J	CHIP R 100 J 1/16W	X1T1E2	
R109			RK73GB1J101J	CHIP R 100 J 1/16W	K1E1M1	
R109			RK73GB1J101J	CHIP R 100 J 1/16W	X1T1E2	
R112-114			RK73GB1J101J	CHIP R 100 J 1/16W		
R115			RK73GB1J473J	CHIP R 47K J 1/16W		
R116,117			RK73GB1J101J	CHIP R 100 J 1/16W	K1E1M1	
R116,117			RK73GB1J101J	CHIP R 100 J 1/16W	X1T1E2	
R118			RD14NB2E101J	RD 100 J 1/4W		
R120			RD14NB2E330J	RD 33 J 1/4W		
R121			RK73GB1J102J	CHIP R 1.0K J 1/16W		
R122			RK73GB1J101J	CHIP R 100 J 1/16W		
R123			RK73GB1J103J	CHIP R 10K J 1/16W		
R124			RK73GB1J101J	CHIP R 100 J 1/16W		
R125			RK73GB1J513J	CHIP R 51K J 1/16W	K1E1M1	
R125			RK73GB1J513J	CHIP R 51K J 1/16W	X1T1E2	
R126,127			RK73GB1J2R2J	CHIP R 2.2 J 1/16W		
R128			RD14NB2E2R7J	RD 2.7 J 1/4W	K1E1M1	
R128			RD14NB2E2R7J	RD 2.7 J 1/4W	X1T1E2	
R191-198			RD14NB2E100J	RD 10 J 1/4W		
R199			RK73GB1J100J	CHIP R 10 J 1/16W		
R200			RK73GB1J101J	CHIP R 100 J 1/16W		
R201			RK73GB1J102J	CHIP R 1.0K J 1/16W		
R205			RK73GB1J681J	CHIP R 680 J 1/16W		
R211,212			RK73GB1J223J	CHIP R 22K J 1/16W		
R213,214			RK73GB1J101J	CHIP R 100 J 1/16W		
R215,216			RK73GB1J750J	CHIP R 75 J 1/16W		
R217			RK73GB1J474J	CHIP R 470K J 1/16W		
R218			RK73GB1J750J	CHIP R 75 J 1/16W		
R219-225			RK73GB1J513J	CHIP R 51K J 1/16W		
R232			RK73GB1J101J	CHIP R 100 J 1/16W		
R249			RK73GB1J103J	CHIP R 10K J 1/16W		
R298,299			RK73GB1J301J	CHIP R 300 J 1/16W		
R301,302			RK73GB1J224J	CHIP R 220K J 1/16W		
R305,306			RK73GB1J221J	CHIP R 220 J 1/16W		
R307,308			RK73GB1J470J	CHIP R 47 J 1/16W		
R311,312			RK73GB1J224J	CHIP R 220K J 1/16W		
R315,316			RK73GB1J221J	CHIP R 220 J 1/16W		
R317,318			RK73GB1J470J	CHIP R 47 J 1/16W		
R321,322			RK73GB1J224J	CHIP R 220K J 1/16W		
R325,326			RK73GB1J221J	CHIP R 220 J 1/16W		
R327,328			RK73GB1J470J	CHIP R 47 J 1/16W		
R331,332			RK73GB1J224J	CHIP R 220K J 1/16W		

L : Scandinavia K : USA P : Canada R : Mexico C : China I : Malaysia
Y : PX(Far East,Hawaii) T : England E : Europe G : Germany V : China(Shanghai)
Y : AAFES(Europe) X : Australia Q : Russia H : Korea M : Other Areas indicates safety critical components .

* New Parts
Parts without **Parts No.** are not supplied.
Les articles non mentionnés dans le **Parts No.** ne sont pas fournis.
Teile ohne **Parts No.** werden nicht geliefert.



Ref. No	Add-ress	New Parts	Parts No.	Description	Desti-nation	Re-marks
R335,336			RK73GB1J221J	CHIP R 220 J 1/16W		
R337,338			RK73GB1J470J	CHIP R 47 J 1/16W		
R341,342			RK73GB1J224J	CHIP R 220K J 1/16W		
R345,346			RK73GB1J221J	CHIP R 220 J 1/16W		
R347,348			RK73GB1J470J	CHIP R 47 J 1/16W		
R351-370			RK73GB1J222J	CHIP R 2.2K J 1/16W		
R380			RK73GB1J104J	CHIP R 100K J 1/16W		
R401			RD14NB2E471J	RD 470 J 1/4W	KK1E1	
R401			RD14NB2E471J	RD 470 J 1/4W	T1E2	
R402			RK73GB1J102J	CHIP R 1.0K J 1/16W	KK1E1	
R402			RK73GB1J102J	CHIP R 1.0K J 1/16W	T1E2	
R403			RK73GB1J473J	CHIP R 47K J 1/16W	KK1E1	
R403			RK73GB1J473J	CHIP R 47K J 1/16W	T1E2	
R404			RK73GB1J102J	CHIP R 1.0K J 1/16W	KK1E1	
R404			RK73GB1J102J	CHIP R 1.0K J 1/16W	T1E2	
R413,414			RD14NB2E101J	RD 100 J 1/4W	E2	
R413,414			RD14NB2E101J	RD 100 J 1/4W	K1E1T1	
R415-418			RK73GB1J223J	CHIP R 22K J 1/16W	E2	
R415-418			RK73GB1J223J	CHIP R 22K J 1/16W	K1E1T1	
R419			RD14NB2E471J	RD 470 J 1/4W	E2	
R419			RD14NB2E471J	RD 470 J 1/4W	K1E1T1	
R420			RK73GB1J102J	CHIP R 1.0K J 1/16W	E2	
R420			RK73GB1J102J	CHIP R 1.0K J 1/16W	K1E1T1	
R421,422			RK73GB1J103J	CHIP R 10K J 1/16W	E2	
R421,422			RK73GB1J103J	CHIP R 10K J 1/16W	K1E1T1	
R423			RK73GB1J102J	CHIP R 1.0K J 1/16W	E2	
R423			RK73GB1J102J	CHIP R 1.0K J 1/16W	K1E1T1	
R424			RD14NB2E101J	RD 100 J 1/4W	KK1E1	
R424			RD14NB2E101J	RD 100 J 1/4W	T1E2	
R425			RK73GB1J102J	CHIP R 1.0K J 1/16W	KK1E1	
R425			RK73GB1J102J	CHIP R 1.0K J 1/16W	T1E2	
R426			RK73GB1J103J	CHIP R 10K J 1/16W	KK1E1	
R426			RK73GB1J103J	CHIP R 10K J 1/16W	T1E2	
R427			RK73GB1J472J	CHIP R 4.7K J 1/16W	KK1E1	
R427			RK73GB1J472J	CHIP R 4.7K J 1/16W	T1E2	
R428,429			RK73GB1J102J	CHIP R 1.0K J 1/16W	KK1E1	
R428,429			RK73GB1J102J	CHIP R 1.0K J 1/16W	T1E2	
R430			RK73GB1J223J	CHIP R 22K J 1/16W	KK1E1	
R430			RK73GB1J223J	CHIP R 22K J 1/16W	T1E2	
R431,432			RD14NB2E471J	RD 470 J 1/4W	KK1E1	
R431,432			RD14NB2E471J	RD 470 J 1/4W	T1E2	
R433			RK73GB1J101J	CHIP R 100 J 1/16W	KK1E1	
R433			RK73GB1J101J	CHIP R 100 J 1/16W	T1E2	
R434			RK73GB1J223J	CHIP R 22K J 1/16W	KK1E1	
R434			RK73GB1J223J	CHIP R 22K J 1/16W	T1E2	
R435			RK73GB1J102J	CHIP R 1.0K J 1/16W	KK1E1	
R435			RK73GB1J102J	CHIP R 1.0K J 1/16W	T1E2	
R436			RK73GB1J272J	CHIP R 2.7K J 1/16W	KK1E1	
R436			RK73GB1J272J	CHIP R 2.7K J 1/16W	T1E2	
R437			RK73GB1J222J	CHIP R 2.2K J 1/16W	KK1E1	
R437			RK73GB1J222J	CHIP R 2.2K J 1/16W	T1E2	
R438			RK73GB1J102J	CHIP R 1.0K J 1/16W	KK1E1	
R438			RK73GB1J102J	CHIP R 1.0K J 1/16W	T1E2	
R439			RD14NB2E471J	RD 470 J 1/4W	KK1E1	
R439			RD14NB2E471J	RD 470 J 1/4W	T1E2	

L : Scandinavia K : USA P : Canada R : Mexico C : China I : Malaysia
Y : PX(Far East,Hawaii) T : England E : Europe G : Germany V : China(Shanghai)
Y : AAFES(Europe) X : Australia Q : Russia H : Korea M : Other Areas indicates safety critical components .

PARTS LIST

KRF-X9995D/X9995D-S/M/R-5700/5900

* New Parts

Parts without **Parts No.** are not supplied.

Les articles non mentionnés dans le **Parts No.** ne sont pas fournis.

Teile ohne **Parts No.** werden nicht geliefert.



Ref. No	Add-ress	New Parts	Parts No.	Description	Desti-nation	Re-marks
R440,441			RK73GB1J473J	CHIP R 47K J 1/16W	KK1E1	
R440,441			RK73GB1J473J	CHIP R 47K J 1/16W	T1E2	
R444			RK73GB1J472J	CHIP R 4.7K J 1/16W	KK1E1	
R444			RK73GB1J472J	CHIP R 4.7K J 1/16W	T1E2	
R445			RK73GB1J102J	CHIP R 1.0K J 1/16W	KK1E1	
R445			RK73GB1J102J	CHIP R 1.0K J 1/16W	T1E2	
R449			RK73GB1J180J	CHIP R 18 J 1/16W	KK1M1	
R449			RK73GB1J180J	CHIP R 18 J 1/16W	X1	
R450			RD14NB2E101J	RD 100 J 1/4W	KK1E1	
R450			RD14NB2E101J	RD 100 J 1/4W	T1E2	
W202			R92-0679-05	CHIP R 0 OHM		
W203			R92-0670-05	CHIP R 0 OHM		
W204			R92-0679-05	CHIP R 0 OHM		
W206			R92-0670-05	CHIP R 0 OHM		
W207			R92-0679-05	CHIP R 0 OHM		
W208			R92-0670-05	CHIP R 0 OHM		
W209			R92-0679-05	CHIP R 0 OHM		
W210			R92-0670-05	CHIP R 0 OHM		
W213			R92-0670-05	CHIP R 0 OHM	K	
W213-217			R92-0670-05	CHIP R 0 OHM	K1E1M1	
W213-217			R92-0670-05	CHIP R 0 OHM	X1T1E2	
W216,217			R92-0670-05	CHIP R 0 OHM	K	
W219			R92-0679-05	CHIP R 0 OHM		
W220			R92-0670-05	CHIP R 0 OHM		
S1 -17			S70-0031-05	TACT SWITCH		
S18			S70-0031-05	TACT SWITCH	K1E1M1	
S18			S70-0031-05	TACT SWITCH	X1T1E2	
S20			S68-0088-05	PUSH SWITCH (POWER TYPE)	E1M1X1	
S20			S68-0088-05	PUSH SWITCH (POWER TYPE)	T1E2	
S19			T99-0602-05	ROTARY ENCODER		
D1 ,2			MTZJ3.3(B)	ZENER DIODE		
D1 ,2			RD3.3ES(B2)	ZENER DIODE		
D13			MTZJ5.1(B)	ZENER DIODE		
D13			RD5.1ES(B2)	ZENER DIODE		
D14			MTZJ5.6(B)	ZENER DIODE		
D14			RD5.6ES(B2)	ZENER DIODE		
D27 ,28			DA204U	DIODE		
D27 ,28			1SS302	DIODE		
D29			MTZJ3.3(B)	ZENER DIODE	K1E1M1	
D29			MTZJ3.3(B)	ZENER DIODE	X1T1E2	
D29			RD3.3ES(B2)	ZENER DIODE	K1E1M1	
D29			RD3.3ES(B2)	ZENER DIODE	X1T1E2	
D403			DA204U	DIODE	KK1E1	
D403			DA204U	DIODE	T1E2	
D403			1SS302	DIODE	KK1E1	
D403			1SS302	DIODE	T1E2	
D405			MTZJ5.6(B)	ZENER DIODE	E2	
D405			MTZJ5.6(B)	ZENER DIODE	K1E1T1	
D405			RD5.6ES(B2)	ZENER DIODE	E2	
D405			RD5.6ES(B2)	ZENER DIODE	K1E1T1	
D406			HSS104A	DIODE	E2	
D406			HSS104A	DIODE	K1E1T1	
D406			1SS133	DIODE	E2	
D406			1SS133	DIODE	K1E1T1	

L : Scandinavia K : USA P : Canada R : Mexico C : China I : Malaysia

Y : PX(Far East,Hawaii) T : England E : Europe G : Germany V : China(Shanghai)

Y : AAFES(Europe) X : Australia Q : Russia H : Korea M : Other Areas indicates safety critical components .

* New Parts

Parts without **Parts No.** are not supplied.

Les articles non mentionnés dans le **Parts No.** ne sont pas fournis.

Teile ohne **Parts No.** werden nicht geliefert.



Ref. No	Add-ress	New Parts	Parts No.	Description	Desti-nation	Re-marks
D407			MTZJ5.1(B)	ZENER DIODE	E2	
D407			MTZJ5.1(B)	ZENER DIODE	K1E1T1	
D407			RD5.1ES(B2)	ZENER DIODE	E2	
D407			RD5.1ES(B2)	ZENER DIODE	K1E1T1	
D408			DA204U	DIODE	KK1E1	
D408			DA204U	DIODE	T1E2	
D408			1SS302	DIODE	KK1E1	
D408			1SS302	DIODE	T1E2	
D410			HSS104A	DIODE	KK1E1	
D410			HSS104A	DIODE	T1E2	
D410			1SS133	DIODE	KK1E1	
D410			1SS133	DIODE	T1E2	
D411			DA204U	DIODE	KK1E1	
D411			DA204U	DIODE	T1E2	
D411			1SS302	DIODE	KK1E1	
D411			1SS302	DIODE	T1E2	
D412,413			HSS104A	DIODE	KK1E1	
D412,413			HSS104A	DIODE	T1E2	
D412,413			1SS133	DIODE	KK1E1	
D412,413			1SS133	DIODE	T1E2	
D414			HSS104A	DIODE	E1T1E2	
D414			1SS133	DIODE	E1T1E2	
ED1			16-MT-62GK	FLUORESCENT INDICATOR TUBE		
IC1			UPD780204-038	MI-COM IC		
IC2			TA8409S	MOS-IC	K1E1M1	
IC2			TA8409S	MOS-IC	X1T1E2	
IC11			TC74HC151AF	MOS-IC		
IC401			TC4W53FU	MOS-IC	KK1E1	
IC401			TC4W53FU	MOS-IC	T1E2	
Q1 -3			2SC3940A(R,S)	TRANSISTOR		
Q4			DTC124EUA	DIGITAL TRANSISTOR		
Q4			UN5212	DIGITAL TRANSISTOR		
Q5 ,6			DTA124EUA	DIGITAL TRANSISTOR		
Q5 ,6			UN5112	DIGITAL TRANSISTOR		
Q7 -16			DTC124EUA	DIGITAL TRANSISTOR		
Q7 -16			UN5212	DIGITAL TRANSISTOR		
Q20			DTA124EUA	DIGITAL TRANSISTOR		
Q20			UN5112	DIGITAL TRANSISTOR		
Q21			DTC124EUA	DIGITAL TRANSISTOR		
Q21			UN5212	DIGITAL TRANSISTOR		
Q301-320			2SC2878(B)	TRANSISTOR		
Q401			2SC4081(R,S)	TRANSISTOR	KK1E1	
Q401			2SC4081(R,S)	TRANSISTOR	T1E2	
Q401			2SC4116(Y,GR)	TRANSISTOR	KK1E1	
Q401			2SC4116(Y,GR)	TRANSISTOR	T1E2	
Q402			DTC124EUA	DIGITAL TRANSISTOR	KK1E1	
Q402			DTC124EUA	DIGITAL TRANSISTOR	T1E2	
Q402			UN5212	DIGITAL TRANSISTOR	KK1E1	
Q402			UN5212	DIGITAL TRANSISTOR	T1E2	
Q406			DTA124EUA	DIGITAL TRANSISTOR	E2	
Q406			DTA124EUA	DIGITAL TRANSISTOR	K1E1T1	
Q406			UN5112	DIGITAL TRANSISTOR	E2	
Q406			UN5112	DIGITAL TRANSISTOR	K1E1T1	
Q407			DTC124EUA	DIGITAL TRANSISTOR	E2	
Q407			DTC124EUA	DIGITAL TRANSISTOR	K1E1T1	

L : Scandinavia K : USA P : Canada R : Mexico C : China I : Malaysia

Y : PX(Far East,Hawaii) T : England E : Europe G : Germany V : China(Shanghai)

Y : AAFES(Europe) X : Australia Q : Russia H : Korea M : Other Areas indicates safety critical components .

PARTS LIST

KRF-X9995D/X9995D-S/VR-5700/5900

* New Parts
Parts without **Parts No.** are not supplied.
Les articles non mentionnés dans le **Parts No.** ne sont pas fournis.
Teile ohne **Parts No.** werden nicht geliefert.

45

Ref. No	Add-ress	New Parts	Parts No.	Description	Desti-nation	Re-marks
Q407			UN5212	DIGITAL TRANSISTOR	E2	
Q407			UN5212	DIGITAL TRANSISTOR	K1E1T1	
Q408			DTA124EUA	DIGITAL TRANSISTOR	E2	
Q408			DTA124EUA	DIGITAL TRANSISTOR	K1E1T1	
Q408			UN5112	DIGITAL TRANSISTOR	E2	
Q408			UN5112	DIGITAL TRANSISTOR	K1E1T1	
Q409			DTC124EUA	DIGITAL TRANSISTOR	E2	
Q409			DTC124EUA	DIGITAL TRANSISTOR	K1E1T1	
Q409			UN5212	DIGITAL TRANSISTOR	E2	
Q409			UN5212	DIGITAL TRANSISTOR	K1E1T1	
Q410			2SC4081(R,S)	TRANSISTOR	E2	
Q410			2SC4081(R,S)	TRANSISTOR	K1E1T1	
Q410			2SC4116(Y,GR)	TRANSISTOR	E2	
Q410			2SC4116(Y,GR)	TRANSISTOR	K1E1T1	
Q411			DTA113ZUA	DIGITAL TRANSISTOR	E2	
Q411			DTA113ZUA	DIGITAL TRANSISTOR	K1E1T1	
Q411			UN5119	DIGITAL TRANSISTOR	E2	
Q411			UN5119	DIGITAL TRANSISTOR	K1E1T1	
Q412			2SA1576A(R,S)	TRANSISTOR	KK1E1	
Q412			2SA1576A(R,S)	TRANSISTOR	T1E2	
Q412			2SA1586(Y,GR)	TRANSISTOR	KK1E1	
Q412			2SA1586(Y,GR)	TRANSISTOR	T1E2	
Q413			DTC124EUA	DIGITAL TRANSISTOR	KK1E1	
Q413			DTC124EUA	DIGITAL TRANSISTOR	T1E2	
Q413			UN5212	DIGITAL TRANSISTOR	KK1E1	
Q413			UN5212	DIGITAL TRANSISTOR	T1E2	
Q414			2SC4081(R,S)	TRANSISTOR	KK1E1	
Q414			2SC4081(R,S)	TRANSISTOR	T1E2	
Q414			2SC4116(Y,GR)	TRANSISTOR	KK1E1	
Q414			2SC4116(Y,GR)	TRANSISTOR	T1E2	
Q415			2SA1576A(R,S)	TRANSISTOR	KK1E1	
Q415			2SA1576A(R,S)	TRANSISTOR	T1E2	
Q415			2SA1586(Y,GR)	TRANSISTOR	KK1E1	
Q415			2SA1586(Y,GR)	TRANSISTOR	T1E2	
Q416,417			2SC4081(R,S)	TRANSISTOR	KK1E1	
Q416,417			2SC4081(R,S)	TRANSISTOR	T1E2	
Q416,417			2SC4116(Y,GR)	TRANSISTOR	KK1E1	
Q416,417			2SC4116(Y,GR)	TRANSISTOR	T1E2	
Q418			DTC124EUA	DIGITAL TRANSISTOR	KK1E1	
Q418			DTC124EUA	DIGITAL TRANSISTOR	T1E2	
Q418			UN5212	DIGITAL TRANSISTOR	KK1E1	
Q418			UN5212	DIGITAL TRANSISTOR	T1E2	
Q419			DTA124EUA	DIGITAL TRANSISTOR	E1T1E2	
Q419			UN5112	DIGITAL TRANSISTOR	E1T1E2	
A1			W02-2734-05	OPTIC RECEIVING MODULE		
A2			W02-2717-05	OSCILLATING MODULE		
A3 -9			W02-2716-05	OPTIC RECEIVING MODULE		
VIDEO (X35-2260-12)						
C1 -9			CC73GCH1H100D	CHIP C	10PF	D
C10 -15			CE04KW1A101M	ELECTRO	100UF	10WV
C16 -18			CE04KW1A471M	ELECTRO	470UF	10WV
C19 -21			CK73GB1C104K	CHIP C	0.10UF	K
C22 -24			CE04KW1H100M	ELECTRO	10UF	50WV
C25 ,26			CC73GCH1H180J	CHIP C	18PF	J

L : Scandinavia K : USA P : Canada R : Mexico C : China I : Malaysia
Y : PX(Far East,Hawaii) T : England E : Europe G : Germany V : China(Shanghai)
Y : AAFES(Europe) X : Australia Q : Russia H : Korea M : Other Areas Δ indicates safety critical components .

* New Parts
Parts without **Parts No.** are not supplied.
Les articles non mentionnés dans le **Parts No.** ne sont pas fournis.
Teile ohne **Parts No.** werden nicht geliefert.

46

Ref. No	Add-ress	New Parts	Parts No.	Description	Desti-nation	Re-marks
C27			CE04KW1E470M	ELECTRO	47UF	25WV
C28 -30			CE04KW1H100M	ELECTRO	10UF	50WV
C31			CC73GCH1H271J	CHIP C	270PF	J
C32			CC73GCH1H391J	CHIP C	390PF	J
C33			CK73GB1H472K	CHIP C	4700PF	K
C34			CE04KW1H2R2M	ELECTRO	2.2UF	50WV
C35			CE04KW1E470M	ELECTRO	47UF	25WV
C36			CK73GB1H103K	CHIP C	0.010UF	K
C37 -39			CE04KW1A101M	ELECTRO	100UF	10WV
C40 ,41			CK73GB1H103K	CHIP C	0.010UF	K
C42			CK73GF1C224Z	CHIP C	0.22UF	Z
C43			CC73GCH1H220J	CHIP C	22PF	J
C44			CC73GCH1H220J	CHIP C	22PF	J
C44			CC73GCH1H220J	CHIP C	22PF	J
C45			CE04KW1H0R1M	ELECTRO	0.1UF	50WV
C46			CK73GB1H103K	CHIP C	0.010UF	K
C47			CE04KW1H4R7M	ELECTRO	4.7UF	50WV
C48			CK73FF1C105Z	CHIP C	1.0UF	Z
C49			CC73GCH1H102J	CHIP C	1000PF	J
C50			CK73GB1H103K	CHIP C	0.010UF	K
C51 ,52			CK73GF1E104Z	CHIP C	0.10UF	Z
C53			CE04KW1H010M	ELECTRO	1.0UF	50WV
C54			CK73GB1H103K	CHIP C	0.010UF	K
C55			CE04KW1A101M	ELECTRO	100UF	10WV
C56			CK73GF1C224Z	CHIP C	0.22UF	Z
C57			CC73GCH1H221J	CHIP C	220PF	J
C58			CE04KW1H2R2M	ELECTRO	2.2UF	50WV
C59			CK73GB1H103K	CHIP C	0.010UF	K
C60			CC73GCH1H102J	CHIP C	1000PF	J
C61			CK73GF1E104Z	CHIP C	0.10UF	Z
C62 -64			CE04KW1A101M	ELECTRO	100UF	10WV
C65 ,66			CK73GB1H103K	CHIP C	0.010UF	K
C67			CE04KW1H100M	ELECTRO	10UF	50WV
C71 ,72			CE04KW1H010M	ELECTRO	1.0UF	50WV
C71 ,72			CE04KW1H010M	ELECTRO	1.0UF	50WV
C73			CK73GB1H222K	CHIP C	2200PF	K
C73			CK73GB1H222K	CHIP C	2200PF	K
C74			CK73GB1H223K	CHIP C	0.022UF	K
C74			CK73GB1H223K	CHIP C	0.022UF	K
C75			CK73GB1H103K	CHIP C	0.010UF	K
C75			CK73GB1H103K	CHIP C	0.010UF	K
C75			CK73GB1H103K	CHIP C	0.010UF	K
C77			CE04KW1H100M	ELECTRO	10UF	50WV
C77			CE04KW1H100M	ELECTRO	10UF	50WV
C78			CE04KW1H3R3M	ELECTRO	3.3UF	50WV
C78			CE04KW1H3R3M	ELECTRO	3.3UF	50WV
C101,102			CE04KW1C470M	ELECTRO	47UF	16WV
C104			CK73GB1H182K	CHIP C	1800PF	K
C105			CC73GCH1H102J	CHIP C	1000PF	J
C106			CE04KW1H220M	ELECTRO	22UF	50WV
C107			CK73FF1C105Z	CHIP C	1.0UF	Z
C108,109			CK73GB1H103K	CHIP C	0.010UF	K
C110			CC73GCH1H101J	CHIP C	100PF	J
C110			CE04KW1E470M	ELECTRO	47UF	25WV
C115			CE04KW1H100M	ELECTRO	10UF	50WV
C152			CE04KW1H100M	ELECTRO	10UF	50WV
C153			CK73GF1E104Z	CHIP C	0.10UF	Z

L : Scandinavia K : USA P : Canada R : Mexico C : China I : Malaysia
Y : PX(Far East,Hawaii) T : England E : Europe G : Germany V : China(Shanghai)
Y : AAFES(Europe) X : Australia Q : Russia H : Korea M : Other Areas Δ indicates safety critical components .

* New Parts
 Parts without **Parts No.** are not supplied.
 Les articles non mentionnés dans le **Parts No.** ne sont pas fournis.
 Teile ohne **Parts No.** werden nicht geliefert.



Ref. No	Add-ress	New Parts	Parts No.	Description	Desti-nation	Re-marks
CN1 J1 -3			E40-9832-05 E63-1126-05	SOCKET FOR PIN ASSY PIN JACK		
X1 X2 X2 X3			L77-2281-05 L77-2282-05 L77-2282-05 L78-0711-05	CRYSTAL RESONATOR(3.579545 MHZ CRYSTAL RESONATOR(4.433619 MHZ CRYSTAL RESONATOR(4.433619 MHZ RESONATOR (500KHZ)	E1M1X1 T1E2	
R1 -6 R7 -9 R10 -12 R13 -15 R16 -20			RK73FB2A750J RK73GB1J104J RK73FB2A680J RK73GB1J1R0J RK73GB1J473J	CHIP R 75 J 1/10W CHIP R 100K J 1/16W CHIP R 68 J 1/10W CHIP R 1 J 1/16W CHIP R 47K J 1/16W		
R21 R22 ,23 R24 R25 ,26 R27			RK73GB1J101J RK73GB1J102J RK73GB1J272J RK73GB1J123J RK73GB1J473J	CHIP R 100 J 1/16W CHIP R 1.0K J 1/16W CHIP R 2.7K J 1/16W CHIP R 12K J 1/16W CHIP R 47K J 1/16W		
R28 R29 R30 R31 R32			RK73GB1J1R0J RK73GB1J100J RK73GB1J1R0J RK73GB1J222J RK73GB1J331J	CHIP R 1 J 1/16W CHIP R 10 J 1/16W CHIP R 1 J 1/16W CHIP R 2.2K J 1/16W CHIP R 330 J 1/16W		
R33 R34 R35 R36 R37			RK73GB1J272J RK73GB1J432J RK73GB1J914J RK73GB1J242J RK73GB1J471J	CHIP R 2.7K J 1/16W CHIP R 4.3K J 1/16W CHIP R 910K J 1/16W CHIP R 2.4K J 1/16W CHIP R 470 J 1/16W	E1M1X1	
R37 R38 R38 R39 R40			RK73GB1J471J RK73GB1J821J RK73GB1J821J RK73GB1J153J RK73GB1J684J	CHIP R 470 J 1/16W CHIP R 820 J 1/16W CHIP R 820 J 1/16W CHIP R 15K J 1/16W CHIP R 680K J 1/16W	T1E2 E1M1X1 T1E2	
R41 R42 R43 R44 R45 ,46			RK73GB1J184J RK73GB1J433J RK73GB1J103J RK73GB1J273J RK73GB1J102J	CHIP R 180K J 1/16W CHIP R 43K J 1/16W CHIP R 10K J 1/16W CHIP R 27K J 1/16W CHIP R 1.0K J 1/16W		
R47 R48 R49 R50 R51			RK73GB1J182J RK73GB1J221J RK73GB1J151J RK73GB1J750J RK73GB1J183J	CHIP R 1.8K J 1/16W CHIP R 220 J 1/16W CHIP R 150 J 1/16W CHIP R 75 J 1/16W CHIP R 18K J 1/16W		
R52 R53 R55 R56 R57			RK73GB1J223J RK73GB1J102J RK73GB1J392J RK73GB1J183J RK73GB1J223J	CHIP R 22K J 1/16W CHIP R 1.0K J 1/16W CHIP R 3.9K J 1/16W CHIP R 18K J 1/16W CHIP R 22K J 1/16W		
R58 R59 R59 R60 R63 -68			RK73GB1J103J RK73GB1J103J RK73GB1J103J RK73GB1J102J RK73GB1J102J	CHIP R 10K J 1/16W CHIP R 10K J 1/16W CHIP R 10K J 1/16W CHIP R 1.0K J 1/16W CHIP R 1.0K J 1/16W	E1M1X1 T1E2	
R69 ,70 R71 R71			RK73GB1J222J RK73GB1J183J RK73GB1J183J	CHIP R 2.2K J 1/16W CHIP R 18K J 1/16W CHIP R 18K J 1/16W	E1M1X1 T1E2	

L : Scandinavia K : USA P : Canada R : Mexico C : China I : Malaysia
 Y : PX(Far East,Hawaii) T : England E : Europe G : Germany V : China(Shanghai)
 Y : AAFES(Europe) X : Australia Q : Russia H : Korea M : Other Areas Δ indicates safety critical components .

* New Parts
 Parts without **Parts No.** are not supplied.
 Les articles non mentionnés dans le **Parts No.** ne sont pas fournis.
 Teile ohne **Parts No.** werden nicht geliefert.



Ref. No	Add-ress	New Parts	Parts No.	Description	Desti-nation	Re-marks
R72 R72 R73 R73 R74			RK73GB1J224J RK73GB1J224J RK73GB1J104J RK73GB1J104J RK73GB1J334J	CHIP R 220K J 1/16W CHIP R 220K J 1/16W CHIP R 100K J 1/16W CHIP R 100K J 1/16W CHIP R 330K J 1/16W	E1M1X1 T1E2 E1M1X1 T1E2 E1M1X1	
R74 R75 R75 R76 R76			RK73GB1J334J RK73GB1J223J RK73GB1J223J RS14KB3A181J RS14KB3A181J	CHIP R 330K J 1/16W CHIP R 22K J 1/16W CHIP R 22K J 1/16W FL-PROOF RS 180 J 1W FL-PROOF RS 180 J 1W	T1E2 E1M1X1 T1E2 E1M1X1 T1E2	
R77 R77 R78 R78 R79			RK73GB1J103J RK73GB1J103J RK73GB1J101J RK73GB1J101J RK73GB1J102J	CHIP R 10K J 1/16W CHIP R 10K J 1/16W CHIP R 100 J 1/16W CHIP R 100 J 1/16W CHIP R 1.0K J 1/16W	E1M1X1 T1E2 E1M1X1 T1E2 E1M1X1	
R79 R80 R81 R81 R82			RK73GB1J102J RK73GB1J473J RK73GB1J1R0J RK73GB1J1R0J RK73GB1J101J	CHIP R 1.0K J 1/16W CHIP R 47K J 1/16W CHIP R 1 J 1/16W CHIP R 1 J 1/16W CHIP R 100 J 1/16W	T1E2 E1M1X1 T1E2	
R83 R84 -86 R87 -90 R93 R94 -100			RK73GB1J1R0J RK73GB1J104J RK73GB1J473J RK73GB1J103J RK73GB1J473J	CHIP R 1 J 1/16W CHIP R 100K J 1/16W CHIP R 47K J 1/16W CHIP R 10K J 1/16W CHIP R 47K J 1/16W		
R101 R102 R103 R104 R105,106			RK73GB1J103J RK73GB1J273J RK73GB1J103J RK73GB1J273J RK73GB1J332J	CHIP R 10K J 1/16W CHIP R 27K J 1/16W CHIP R 10K J 1/16W CHIP R 27K J 1/16W CHIP R 3.3K J 1/16W		
R107 R108 R109 R110 R111			RK73GB1J182J RK73GB1J103J RK73GB1J223J RK73GB1J103J RK73GB1J104J	CHIP R 1.8K J 1/16W CHIP R 10K J 1/16W CHIP R 22K J 1/16W CHIP R 10K J 1/16W CHIP R 100K J 1/16W		
R112 R113 R114 R115,116 R117			RK73GB1J101J RK73GB1J474J RK73GB1J183J RK73GB1J103J RK73GB1J222J	CHIP R 100 J 1/16W CHIP R 470K J 1/16W CHIP R 18K J 1/16W CHIP R 10K J 1/16W CHIP R 2.2K J 1/16W		
R118 R119 R120-132 R139-144 R151,152			RK73GB1J103J RK73GB1J1R0J RK73GB1J473J RK73GB1J4R7J RK73GB1J1R0J	CHIP R 10K J 1/16W CHIP R 1 J 1/16W CHIP R 47K J 1/16W CHIP R 4.7 J 1/16W CHIP R 1 J 1/16W		
R153,154 VR1 ,2 W1 -3			RK73GB1J102J R12-3100-05 R92-1963-05	CHIP R 1.0K J 1/16W TRIMMING POT.(10K) JUMPER WIRE (RESISTOR TYPE)		
Δ K1			S76-0123-05			
D1 D1 D1 D1 D2			DAN202J DAN202J 1SS301 1SS301 UDZ11B	DIODE DIODE DIODE DIODE ZENER DIODE	E1M1X1 T1E2 E1M1X1 T1E2 E1M1X1	

L : Scandinavia K : USA P : Canada R : Mexico C : China I : Malaysia
 Y : PX(Far East,Hawaii) T : England E : Europe G : Germany V : China(Shanghai)
 Y : AAFES(Europe) X : Australia Q : Russia H : Korea M : Other Areas Δ indicates safety critical components .

PARTS LIST

KRF-X9995D/X9995D-S/VR-5700/5900

* New Parts
 Parts without **Parts No.** are not supplied.
 Les articles non mentionnés dans le **Parts No.** ne sont pas fournis.
 Teile ohne **Parts No.** werden nicht geliefert.

49

Ref. No	Address	New Parts	Parts No.	Description	Destination	Remarks
D2			UDZ11B	ZENER DIODE	T1E2	
D3			DAP202U	DIODE		
D3			1SS300	DIODE		
D4			DA204U	DIODE		
D4			1SS302	DIODE		
D5			MAII		KK1	
IC1 -3		*	ADG704BRM	ANALOGUE IC		
IC4		*	CLC5623IM	ANALOGUE IC		
IC5			UPC1830GT	ANALOGUE IC		
IC6			AN5560	ANALOGUE IC	E1M1X1	
IC6			AN5560	ANALOGUE IC	T1E2	
IC7			BA7071F	ANALOGUE IC	E1M1X1	
IC7			BA7071F	ANALOGUE IC	T1E2	
IC8	Δ		UPC29M05HB	ANALOGUE IC		
IC10			NJM4565M	ANALOGUE IC		
Q1			2SC4081(R,S)	TRANSISTOR		
Q1			2SC4116(Y,GR)	TRANSISTOR		
Q2			2SA1576A(R,S)	TRANSISTOR		
Q2			2SA1586(Y,GR)	TRANSISTOR		
Q3			2SC4081(R,S)	TRANSISTOR		
Q3			2SC4116(Y,GR)	TRANSISTOR		
Q5			DTC124EUA	DIGITAL TRANSISTOR	E1M1X1	
Q5			DTC124EUA	DIGITAL TRANSISTOR	T1E2	
Q5			UN5212	DIGITAL TRANSISTOR	E1M1X1	
Q5			UN5212	DIGITAL TRANSISTOR	T1E2	
Q6			DTC143TUA	DIGITAL TRANSISTOR	E1M1X1	
Q6			DTC143TUA	DIGITAL TRANSISTOR	T1E2	
Q6			UN5216	DIGITAL TRANSISTOR	E1M1X1	
Q6			UN5216	DIGITAL TRANSISTOR	T1E2	
Q7 ,8			DTA124EUA	DIGITAL TRANSISTOR		
Q7 ,8			UN5112	DIGITAL TRANSISTOR		
Q9 ,10			DTC124EUA	DIGITAL TRANSISTOR		
Q9 ,10			UN5212	DIGITAL TRANSISTOR		
Q11			2SC4081(R,S)	TRANSISTOR		
Q11			2SC4116(Y,GR)	TRANSISTOR		
Q12 ,13			DTC124EUA	DIGITAL TRANSISTOR	E1M1X1	
Q12 ,13			DTC124EUA	DIGITAL TRANSISTOR	T1E2	
Q12 ,13			UN5212	DIGITAL TRANSISTOR	E1M1X1	
Q12 ,13			UN5212	DIGITAL TRANSISTOR	T1E2	
Q15 -17			2SC4213(B)	TRANSISTOR		

L : Scandinavia K : USA P : Canada R : Mexico C : China I : Malaysia
 Y : PX(Far East,Hawaii) T : England E : Europe G : Germany V : China(Shanghai)
 Y : AAFES(Europe) X : Australia Q : Russia H : Korea M : Other Areas Δ indicates safety critical components .

PARTS LIST

HOW TO READ THE PARTS LIST

ABBREVIATION OF MODEL AND MASS PRODUCTIONS DESTINATIONS

MODEL	ABB.	Australia	Canada	China	England	Europe	Germany	Korea	Malaysia
		X	P	C	T	E	G	H	I
VR-5700		-	-	-	-	-	-	-	-
VR-5900		-	-	-	-	-	-	-	-
KRF-X9995D		-	-	-	-	E1	-	-	-
KRF-X9995D-S		X1	-	-	T1	E2	-	-	-
MODEL	ABB.	Mexico	PX/AAFES	Russia	Scandinavia	Shanghai	USA	Other area	
		R	Y	Q	L	V	K	M	
VR-5700		-	-	-	-	-	K	-	
VR-5900		-	-	-	-	-	K1	-	
KRF-X9995D		-	-	-	-	-	-	-	
KRF-X9995D-S		-	-	-	-	-	-	M1	

KRF-X9995D/X9995D-S/VR-5700/5900

SPECIFICATIONS

NOTE: Do not use contact cleaning agents because they could cause a malfunction. Be especially careful not to use contact cleaning agents containing oil, since they may deform the plastic components.

KRF-X9995D (for U.K.)

Audio Section

Rated Output Power during stereo operation
1 kHz, 0.03% T.H.D., 6Ω (DIN/IEC) 140W + 140 W
20 Hz ~ 20 kHz, 0.03% T.H.D., 6Ω (IEC) 130W + 130 W

Effective Output Power during surround operation
1 kHz, 0.06% T.H.D. at 6 Ω, all channel driven
(Front, Center, Surround) 130 W × 5

Total Harmonic Distortion 0.005 % (1 kHz, 65 W, 6 Ω)

Frequency Response (IHF'66)
Line (CD1, MD/TAPE, CD2/TAPE2 MONITOR, CD-R, VIDEO 1 - 4, DVD/6CH.) 7 Hz ~ 100 kHz, 0 dB, -3 dB

Signal to Noise Ratio (IHF '66)
PHONO (MM) 76 dB
CD1 98 dB

Input Sensitivity / Impedance
PHONO (MM) 4.0 mV / 47 kΩ
CD1 300 mV / 47 kΩ
DVD/6CH. 300 mV / 47 kΩ

Output Level / Impedance
TAPE REC 300 mV / 2.2 kΩ
PRE OUT (Front, Center, Surround, Surround back) 1 V / 470 Ω
PRE OUT (Subwoofer) 1.8 V / 470 Ω

Tone Control
Bass ± 7 dB (at 100 Hz)
Treble ± 7 dB (at 10 kHz)

Loudness Control Volume at -30 dB level
..... +6 dB (100 Hz), +3 dB (10 kHz)

Digital Audio Section

Sampling Frequency 32 kHz, 44.1 kHz, 48 kHz, 96 kHz
Input Level / Impedance / Wavelength
Optical -15 dBm ~ -21 dBm, 660 nm ±30 nm
Coaxial 0.5 Vp-p / 75 Ω

Output Level / Impedance / Wavelength
Optical -15 dBm ~ -21 dBm, 660 nm ±30 nm
Coaxial 0.5 Vp-p / 75 Ω

Video Section

Video Inputs / Outputs
Video (composite) 1 Vp-p / 75 Ω
S Video (luminance signal) 1 Vp-p / 75 Ω
(chrominance signal) 0.286 Vp-p / 75 Ω
Component (luminance signal) 1 Vp-p / 75 Ω
(Pb/Pb-signal) ±0.350 Vp-p / 75 Ω

FM Tuner Section

Tuning Frequency Range 87.5 MHz ~ 108 MHz
Usable Sensitivity (DIN at 75 Ω)
Mono 1.3 μV / 13.2 dBf (40 kHz dev., S/N 26 dB)
Stereo 35.1 μV / 42.1 dBf (46 kHz dev., S/N 46 dB)

Total Harmonic Distortion (DIN at 1 kHz)
Mono 0.2 % (71.2 dBf input)
Stereo 0.8 % (71.2 dBf input)

Signal to Noise Ratio (DIN weighted, 1kHz)
Mono 65 dB (40 kHz dev., 71.2 dBf input)
Stereo 60 dB (40 kHz dev., 71.2 dBf input)

Stereo Separation (DIN at 1 kHz) 36 dB
Selectivity (DIN ±300 kHz) 64 dB
Frequency Response 30 Hz ~ 15 kHz, +0.5 dB, -3.0 dB

AM Tuner Section

Tuning Frequency Range 531 kHz ~ 1,602 kHz
Usable Sensitivity (30 % mod., S/N 20 dB)
..... 16 μV / (500 μV/m)

Signal to Noise Ratio (30 % mod., 1 mV input) 50 dB

Relay and IR In/Out Section

Relay Control Terminal
Maximum Output Current 20 mA
Operating Voltage 12 V
Output Impedance 470 Ω

IR Receiver In Terminal
Maximum Output Current 20 mA
Operating Voltage 12 V
Output Impedance 470 Ω

IR Out LCD Remote Terminal
Maximum Output Current 20 mA
Operating Voltage 5 V
Output Impedance 470 Ω

SHAPE OF PLUG TO BE CONNECTED:

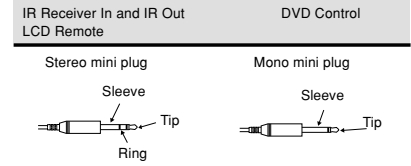

IR IN/OUT SPECIFICATION:

	Terminal	Terminal
	IR Receiver In	IR Out LCD Remote
To Tip	Signal	Signal
To Ring	Ground	—
To Sleeve	+12V	Ground

RELAY CONTROL SPECIFICATION:

	status	status	status
	Power Off	Power On	When a specific button on one of PowerTouch's screen is pressed.
To Tip	0V	0V	+12V
To Ring	0V	+12V	—
To Sleeve	Ground	Ground	Ground

General

Power consumption 600 W
AC outlet
Switched 2 (total 90 W max.)
Dimensions W : 480mm
H : 191mm
D : 416mm
Weight (Net) 20.2 kg

KRF-X9995D (for Other Countries)

Audio Section

Rated Output Power during stereo operation
20 Hz ~ 20 kHz, 0.7% T.H.D., 6Ω (IEC) 150W + 150 W
130 watts per channel minimum RMS, both channels driven, at 6 Ω from 20Hz to 20kHz with no more than 0.05% total harmonic distortion (FTC).

Effective Output Power during stereo operation
1 kHz, 10% T.H.D. at 6 Ω 180 W + 180 W

Effective Output Power during surround operation
Front
1 kHz, 10% T.H.D. at 6 Ω, one channel driven 200 W + 200 W
Center
1 kHz, 10% T.H.D. at 6 Ω, one channel driven 200 W + 200 W
Surround
1 kHz, 10% T.H.D. at 6 Ω, one channel driven 200 W + 200 W

Total Harmonic Distortion 0.005 % (1 kHz, 75 W, 6 Ω)

Frequency Response (IHF'66)
Line (CD1, MD/TAPE, CD2/TAPE2 MONITOR, CD-R, VIDEO 1 - 4, DVD/6CH.) 7 Hz ~ 100 kHz, 0 dB, -3 dB

Signal to Noise Ratio (IHF '66)
PHONO (MM) 76 dB
CD1 98 dB

Input Sensitivity / Impedance
PHONO (MM) 4.0 mV / 47 kΩ
CD1 300 mV / 47 kΩ
DVD/6CH. 300 mV / 47 kΩ

Output Level / Impedance
TAPE REC 300 mV / 2.2 kΩ
PRE OUT (Front, Center, Surround, Surround back) 1 V / 470 Ω
PRE OUT (Subwoofer) 1.8 V / 470 Ω

Tone Control
Bass ± 7 dB (at 100 Hz)
Treble ± 7 dB (at 10 kHz)

Loudness Control
Volume at -30 dB level +6 dB (100 Hz), +3 dB (10 kHz)

Digital Audio Section

Sampling Frequency 32 kHz, 44.1 kHz, 48 kHz, 96 kHz
Input Level / Impedance / Wavelength
Optical -15 dBm ~ -21 dBm, 660 nm ±30 nm
Coaxial 0.5 Vp-p / 75 Ω

Output Level / Impedance / Wavelength
Optical -15 dBm ~ -21 dBm, 660 nm ±30 nm
Coaxial 0.5 Vp-p / 75 Ω

Video Section

Video Inputs / Outputs
Video (composite) 1 Vp-p / 75 Ω
S Video (luminance signal) 1 Vp-p / 75 Ω
(chrominance signal) 0.286 Vp-p / 75 Ω
Component (luminance signal) 1 Vp-p / 75 Ω
(Cb/Cr-signal) ±0.350 Vp-p / 75 Ω

FM Tuner Section

Tuning Frequency Range 87.5 MHz ~ 108 MHz
Usable Sensitivity (Mono) 1.3 μV (75 Ω) / 13.2 dBf (75 kHz dev., sinad 30 dB)
50dB Quieting Sensitivity
Stereo 25.1 μV (75 Ω) / 39.2 dBf

Total Harmonic Distortion (1 kHz)
Mono 0.3 % (71.2 dBf input)
Stereo 0.5 % (71.2 dBf input)

Signal to Noise Ratio (1 kHz, 75 kHz DEV.)
Mono 75 dB (71.2 dBf input)
Stereo 70 dB (71.2 dBf input)

Stereo Separation (1 kHz) 40 dB
Selectivity (±400 kHz) 50 dB
Frequency Response 30 Hz ~ 15 kHz, +0.5 dB, -3.0 dB

AM Tuner Section

Tuning Frequency Range
9kHz step 531 kHz ~ 1,602 kHz
10kHz step 530 kHz ~ 1,610 kHz

Usable Sensitivity (30 % mod., S/N 20 dB)
..... 16 μV / (500 μV/m)

Signal to Noise Ratio (30 % mod. 1 mV input) 50 dB

General

Power consumption 600 W
AC outlet
Switched (except for Australia) 2 (total 90 W max.)
Switched (for Australia) 1 (total 90 W max.)
Dimensions W : 480mm
H : 191mm
D : 416mm
Weight (Net) 22.2 kg

Kenwood follows a policy of continuous advancements in development. For this reason, specifications may be changed without notice. Full performance may not be exhibited in extremely cold locations (below 0 deg. C).

SPECIFICATIONS

VR-5700

Audio Section

Rated Output Power during stereo operation

120 watts per channel minimum RMS, both channels driven, at 6 Ω from 20Hz to 20kHz with no more than 0.03% total harmonic distortion (FTC).

Effective Output Power during surround operation

1 kHz, 0.06% T.H.D. at 6 Ω, all channel driven (Front, Center, Surround) 120 W × 5

Total Harmonic Distortion 0.005 % (1 kHz, 60 W, 6 Ω)

Frequency Response (IHF '66)

Line (CD1, MD/TAPE, CD2/TAPE2 MONITOR, CD-R, VIDEO 1 - 4, DVD/6CH) 7 Hz ~ 100 kHz, 0 dB, -3 dB

Signal to Noise Ratio (IHF '66)

PHONO (MM) 76 dB
CD1 98 dB

Input Sensitivity / Impedance

PHONO (MM) 4.0 mV / 47 kΩ
CD1 300 mV / 47 kΩ
DVD/6CH 300 mV / 47 kΩ

Output Level / Impedance

TAPE REC 300 mV / 2.2 k Ω
PRE OUT (Front, Center, Surround, Surround back) 1 V / 470 Ω
PRE OUT (Subwoofer) 1.8 V / 470 Ω

Tone Control

Bass ± 7 dB (at 100 Hz)
Treble ± 7 dB (at 10 kHz)

Loudness Control

Volume at -30 dB level +6 dB (100 Hz), +3 dB (10 kHz)

Digital Audio Section

Sampling Frequency 32 kHz, 44.1 kHz, 48 kHz, 96 kHz

Input Level / Impedance / Wavelength

Optical -15 dBm ~ -21 dBm, 660 nm ±30 nm
Coaxial 0.5 Vp-p / 75 Ω

Output Level / Impedance / Wavelength

Optical -15 dBm ~ -21 dBm, 660 nm ±30 nm
Coaxial 0.5 Vp-p / 75 Ω

Video Section

Video Inputs / Outputs

Video (composite) 1 Vp-p / 75 Ω
S Video (luminance signal) 1 Vp-p / 75 Ω
(chrominance signal) 0.286 Vp-p / 75 Ω
Component (luminance signal) 1 Vp-p / 75 Ω
(Pb/Pr-signal) ±0.324 Vp-p / 75 Ω

FM Tuner Section

Tuning Frequency Range 87.5 MHz ~ 108 MHz

Usable Sensitivity (Mono)

..... 1.2 μV (75 Ω) / 12.2 dBf (75 kHz dev., sinad 30 dB)

50dB Quieting Sensitivity

Stereo 22.4 μV (75Ω) / 38.2 dBf

Total Harmonic Distortion (1 kHz)

Mono 0.3 % (71.2 dBf input)
Stereo 0.5 % (71.2 dBf input)

Signal to Noise Ratio (1 kHz, 75 kHz DEV.)

Mono 75 dB (71.2 dBf input)
Stereo 70 dB (71.2 dBf input)

Stereo Separation (1 kHz)

..... 40 dB

Selectivity (±400 kHz)

..... 70 dB

Frequency Response 30 Hz ~ 15 kHz, +0.5 dB, -3.0 dB

AM Tuner Section

Tuning Frequency Range

..... 530 kHz ~ 1,700 kHz

Usable Sensitivity (30 % mod., S/N 20 dB)

..... 16 μV / (500 μV/m)

Signal to Noise Ratio (30 % mod. 1 mV input) 50 dB

IR In/Out Section

IR Receiver In Terminal

Maximum Output Current 20mA
Operating Voltage 12V
Output Impedance 470Ω

IR Out LCD Remote Terminal

Maximum Output Current 20mA
Operating Voltage 5V
Output Impedance 470Ω

IR Repeater Out Terminal

Maximum Output Current 20mA
Operating Voltage 12V
Output Impedance 470Ω

SHAPE OF PLUG TO BE CONNECTED:

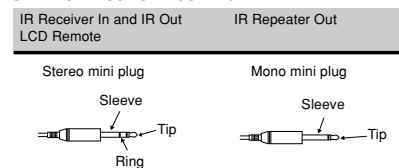

IR IN/OUT SPECIFICATION:

Terminal	IR Receiver In	IR Out LCD Remote
To Tip	Signal	Signal
To Ground	Ground	—
To Sleeve	+12V	Ground

General

Power consumption 6.2 A

AC outlet Switched 2 (total 90W, 0.75 A max.)

Dimensions W: 440mm (17-5/16")

..... H: 191mm (7-1/2")

..... D: 416mm (16-3/8")

Weight (Net) 18.2kg (40.1lb)

VR-5900

Audio Section

Rated Output Power during stereo operation

130 watts per channel minimum RMS, both channels driven, at 6 Ω from 20 Hz to 20 kHz with no more than 0.03% total harmonic distortion (FTC).

Effective Output Power during surround operation

1 kHz, 0.06% T.H.D. at 6 Ω, all channel driven (Front, Center, Surround) 130 W × 5

Total Harmonic Distortion 0.005 % (1 kHz, 65 W, 6 Ω)

Frequency Response (IHF '66)

Line (CD1, MD/TAPE, CD2/TAPE2 MONITOR, CD-R, VIDEO 1 - 4, DVD/6CH) 7 Hz ~ 100 kHz, 0 dB, -3 dB

Signal to Noise Ratio (IHF '66)

PHONO (MM) 76 dB
CD1 98 dB

Input Sensitivity / Impedance

PHONO (MM) 4.0 mV / 47 kΩ
CD1 300 mV / 47 kΩ
DVD/6CH 300 mV / 47 kΩ

Output Level / Impedance

TAPE REC 300 mV / 2.2 k Ω
PRE OUT (Front, Center, Surround, Surround back) 1 V / 470 Ω
PRE OUT (Subwoofer) 1.8 V / 470 Ω

Tone Control

Bass ± 7 dB (at 100 Hz)
Treble ± 7 dB (at 10 kHz)

Loudness Control

Volume at -30 dB level +6 dB (100 Hz), +3 dB (10 kHz)

Digital Audio Section

Sampling Frequency 32 kHz, 44.1 kHz, 48 kHz, 96 kHz

Input Level / Impedance / Wavelength

Optical -15 dBm ~ -21 dBm, 660 nm ±30 nm
Coaxial 0.5 Vp-p / 75 Ω

Output Level / Impedance / Wavelength

Optical -15 dBm ~ -21 dBm, 660 nm ±30 nm
Coaxial 0.5 Vp-p / 75 Ω

FM Tuner Section

Tuning Frequency Range 87.5 MHz ~ 108 MHz

Usable Sensitivity (Mono)

..... 1.2 μV (75 Ω) / 12.2 dBf (75 kHz dev., sinad 30 dB)

50dB Quieting Sensitivity

Stereo 22.4 μV (75Ω) / 38.2 dBf

Total Harmonic Distortion (1 kHz)

Mono 0.3 % (71.2 dBf input)
Stereo 0.5 % (71.2 dBf input)

Signal to Noise Ratio (1 kHz, 75 kHz DEV.)

Mono 75 dB (71.2 dBf input)
Stereo 70 dB (71.2 dBf input)

Stereo Separation (1 kHz)

..... 40 dB

Selectivity (±400 kHz)

..... 70 dB

Frequency Response 30 Hz ~ 15 kHz, +0.5 dB, -3.0 dB

AM Tuner Section

Tuning Frequency Range

..... 530 kHz ~ 1,700 kHz

Usable Sensitivity (30 % mod., S/N 20 dB)

..... 16 μV / (500 μV/m)

Signal to Noise Ratio (30 % mod. 1 mV input) 50 dB

Relay and IR In/Out Section

Relay Control Terminal

Maximum Output Current 20 mA
Operating Voltage 12 V
Output Impedance 470 Ω

IR Receiver In Terminal

Maximum Output Current 20 mA
Operating Voltage 12 V
Output Impedance 470 Ω

IR Out LCD Remote Terminal

Maximum Output Current 20 mA
Operating Voltage 5 V
Output Impedance 470 Ω

IR Repeater Control Terminal

Maximum Output Current 20 mA
Operating Voltage 12 V
Output Impedance 470 Ω

SHAPE OF PLUG TO BE CONNECTED:

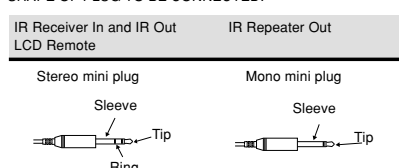

IR IN/OUT SPECIFICATION:

	Terminal	IR Receiver In	IR Out LCD Remote
To Tip	Signal	Signal	Signal
To Ring	Ground	—	—
To Sleeve	+12V	Ground	Ground

RELAY CONTROL SPECIFICATION:

	status	Power Off	Power On	When a specific button on one of PowerTouch III's screen is pressed.
To Tip	0V	0V	+12V	
To Ring	0V	+12V	—	
To Sleeve	Ground	Ground	Ground	

General

Power consumption 6.2 A

AC outlet

Switched 2 (total 90 W, 0.75 A max.)

Dimensions W: 440 mm (17-5/16")

..... H: 191 mm (7-1/2")

..... D: 416 mm (16-3/8")

Weight (Net) 19.9 kg (43.8 lb)

KRF-X9995D/X9995D-S/VR-5700/5900

KENWOOD CORPORATION

14-6,Dogenzaka 1-chome, Shibuya-ku, Tokyo, 150-8501 Japan

KENWOOD SERVICE CORPORATION

P.O BOX 22745, 2201 East Dominguez St., Long Beach, CA 90801-5745, U.S.A.

KENWOOD ELECTRONICS CANADA INC.

6070 Kestrel Road, Mississauga, Ontario, Canada L5T 1S8

KENWOOD ELECTRONICS LATIN AMERICA S.A.

P.O BOX 55-2791, Piso 6 plaza Chase, Cl. 47 y Aquilino de la Guardia Panama, Republic de Panama

KENWOOD ELECTRONICS BRASIL LTDA.

Av. Moema, 170-17', Andar-Cobertura "B", Ed. Maximum Service Center, 04077-020 Moema, São Paulo-SP-Brasil

KENWOOD ELECTRONICS U.K. LIMITED

KENWOOD House, Dwight Road, Watford, Herts., WD1 8EB., United Kingdom

KENWOOD ELECTRONICS BELGUM N.V.

Meachelsesteenweg 418, B-1930 Zaventem, Belgium

KENWOOD ELECTRONICS DEUTSCHLAND GMBH

Rembrücker Str. 15, 63150 Heusenstamm, Germany

KENWOOD ELECTRONICS FRANCE S.A.

13 Boulevard Ney, 75018 Paris, France

KENWOOD ELECTRONICS ITALIA S.p.A.

Via G. Sirtori, 7/9 20129, Milano, Italy

KENWOOD IBÉRICA S.A.

Bolivia, 239-08020 Barcelona, Spain

KENWOOD ELECTRONICS AUSTRALIA PTY. LTD.

(A.C.N. 001 499 074)
16 Giffnock Avenue, North Ryde, N.S.W. 2113, Australia

KENWOOD ELECTRONICS (HONG KONG) LTD.

Unit 3712-3724, Level 37, Tower 1, Metroplaza, 223 Hing Fong Road, Kwai Fong N.T., Hong Kong

KENWOOD ELECTRONICS GULF FZE

P.O.Box 61318, Jebel Ali, Dubai, U.A.E.

KENWOOD ELECTRONICS SINGAPORE PTE LTD.

No. 1 Genting Lane #02-02, KENWOOD Building, Singapore, 349544

KENWOOD ELECTRONICS (MALAYSIA) SDN BHD.

#4.01 Level 4, Wisma Academy Lot 4A, Jalan 19/1 46300 Petaling Jaya Selangor Darul Ehsan Malaysia

KENWOOD ELECTRONICS (THAILAND) CO., LTD.

2019 New Pechburi Road, Bangkapi, Huaykwang, Bangkok, 10320 Thailand