

KRF-V5090D/V5090D-S KRF-V6090D/V6090D-S VR-905/905-S/906/906-S SERVICE MANUAL

© 2004-12 PRINTED IN KOREA
B51-5941-00 (K/K) 1010

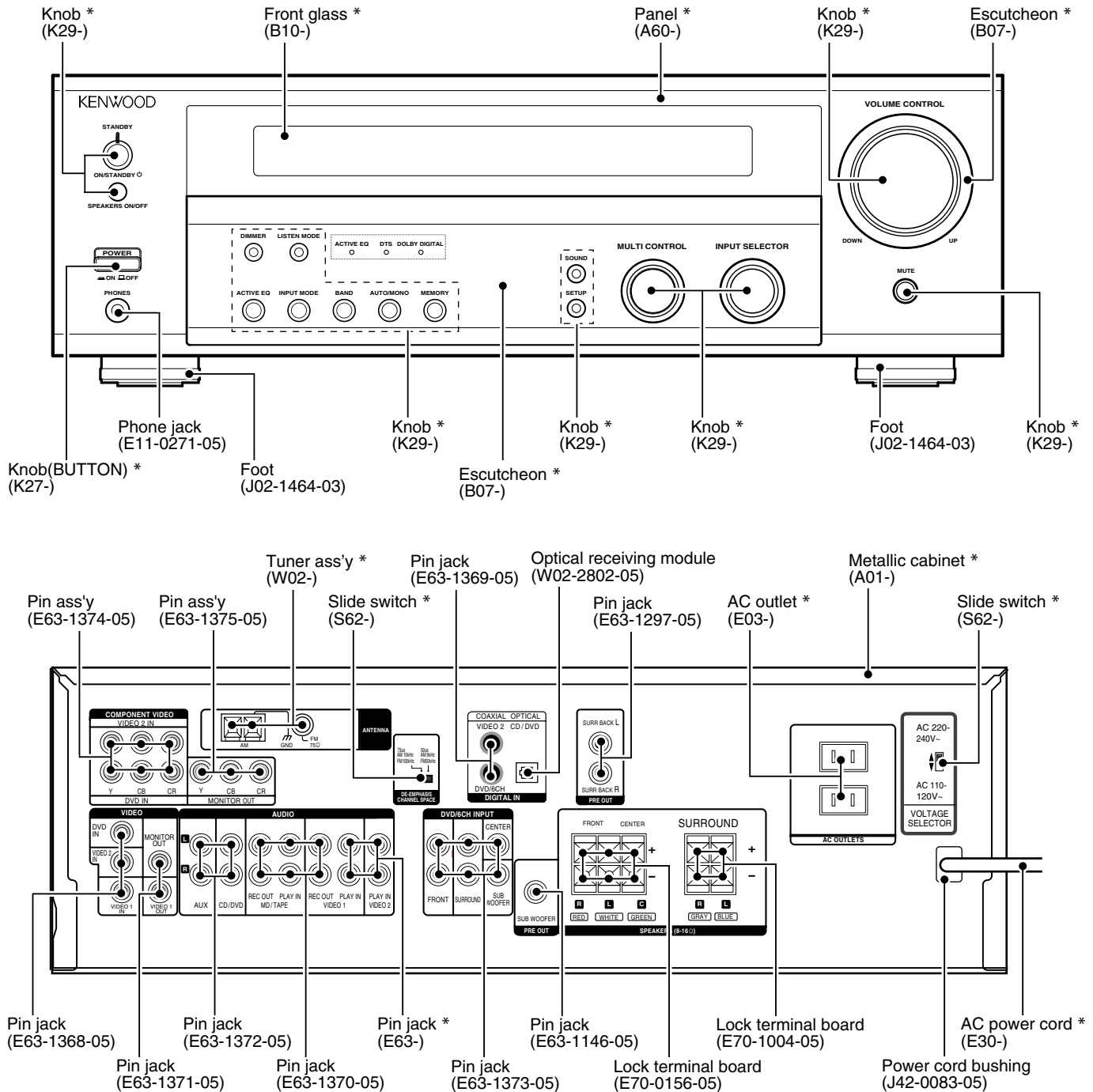

Illust. is KRF-V5090D.

* Refer to parts list on page 23.



This product uses
LEAD-FREE SOLDER



KRF-V5090D/V6090D/VR-905/906

ACCESSORIES / CAUTIONS

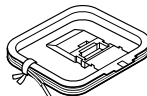
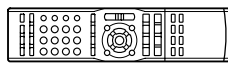
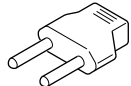
Accessories

<p>FM indoor antenna (1) (T90-0855-05): YXE (T90-0905-05): KP</p> 	<p>AM loop antenna (1) (T90-0893-05)</p> 	<p>Remote control unit (1) RC-R0630/R0630E (A70-1669-05): KPY (A70-1670-05): EX</p> 	<p>*AC plug adapter (1) (E03-0508-05)</p> 
<p>Batteries (R03/AAA) (2)</p> 			<p>*Use to adapter the plug on the power cord to the sape of the wall outlet. (Accessory only for regions where use is necessary.)</p>

MODEL vs UNIT

MODEL		SURROUND	AUDIO	DISPLAY	ELECTRIC
VR-906/-S	K	X08-3420-10	X09-6970-10	X14-7930-10	
VR-906/-S	P				
KRF-V6090D	Y	X08-3422-91	X09-6972-91	X14-7932-91	X25-6730-10
KRF-V6090D-S	X	X08-3420-11	X09-6970-71	X14-7930-71	
KRF-V6090D/D-S	E		X09-6972-71	X14-7932-71	
VR-905-S	K	X08-3420-10	X09-6970-11	X14-7930-11	-
VR-905/-S	P				
KRF-V5090D/D-S	Y	X08-3422-92	X09-6972-92	X14-7932-92	X25-6730-10
KRF-V5090D-S	X	X08-3420-10	X09-6970-72	X14-7930-72	
KRF-V5090D/D-S	E		X09-6972-72	X14-7932-72	

Cautions

<p>Resetting the Microcomputer</p> <p>The microcomputer may malfunction (unit cannot be operated, or shows an erroneous display) if the power cord is unplugged while the power is ON, or due to some other external factor. If this happens, execute the following procedure to reset the microcomputer and return the unit to its normal operating condition.</p> <ul style="list-style-type: none"> Please note that resetting the microcomputer will clear the contents of the memory and return the unit to the state it was in when it left the factory. 	<p>For the U.S.A. and Canada</p> <p>Unplug the power cord from the wall outlet, then plug it back in while holding down the POWER ON/STANDBY key.</p> <p>For other countries</p> <p>With the power cord plugged in, turn the POWER ON/OFF key OFF. Then, while holding down the ON/STANDBY key, press POWER ON/OFF key.</p>
--	---

PC BOARD (Component side view)

X25-6730-10 (J75-0057-02)

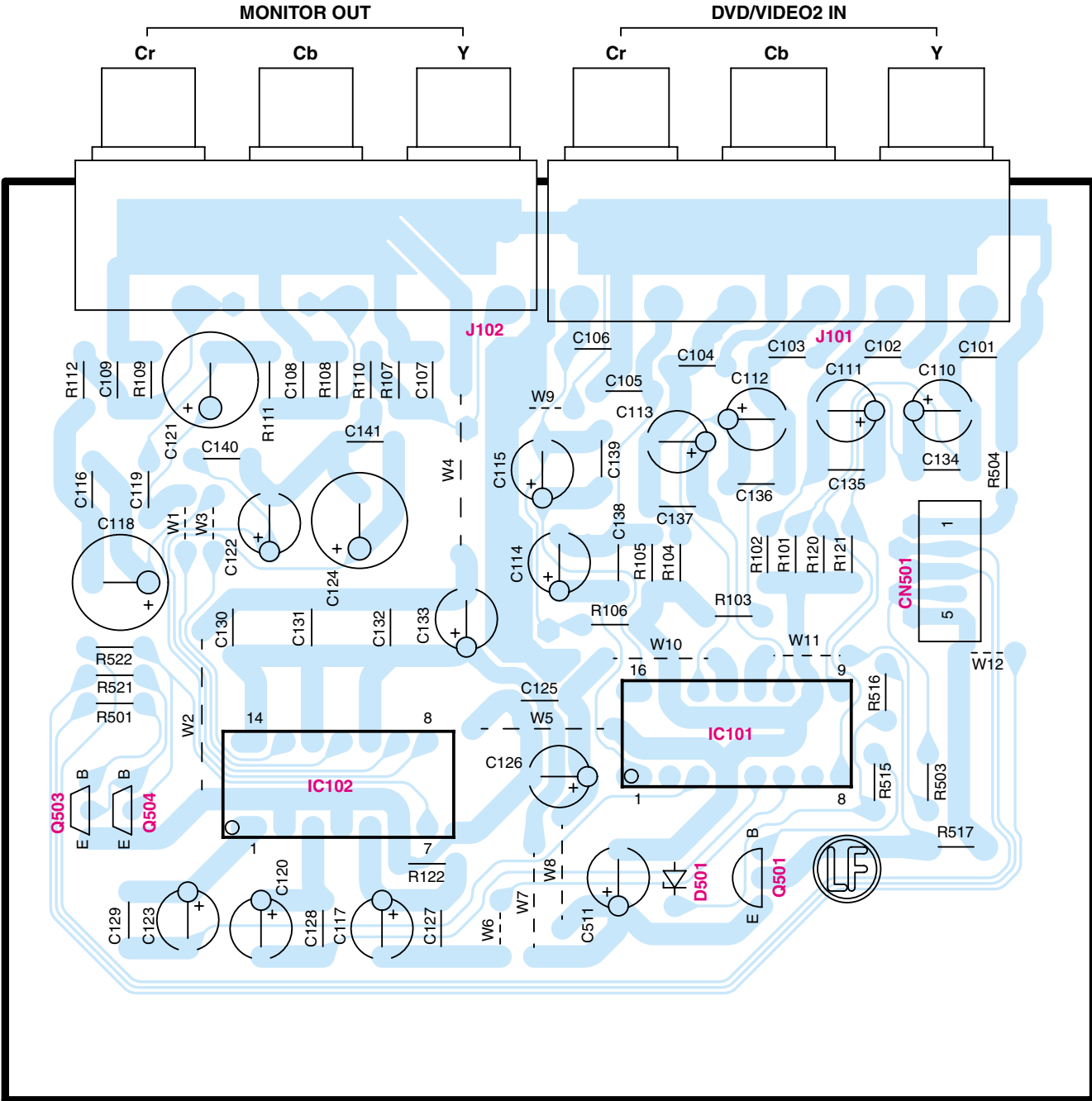

PC BOARD(Component side view)

X08-3420-10 (J75-0054-02) (SIDE A)

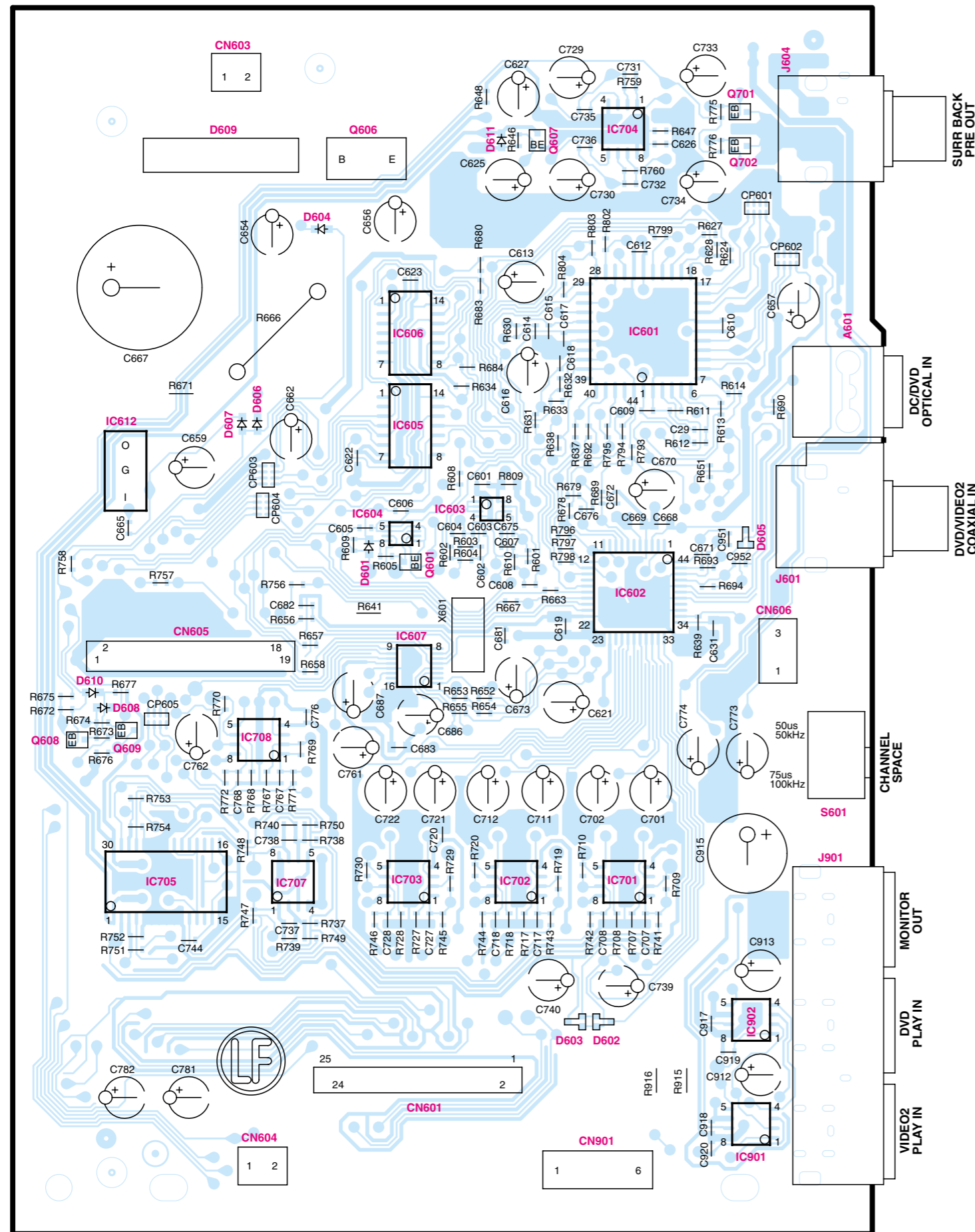

X08-3420-10 (J75-0054-02) (SIDE B)

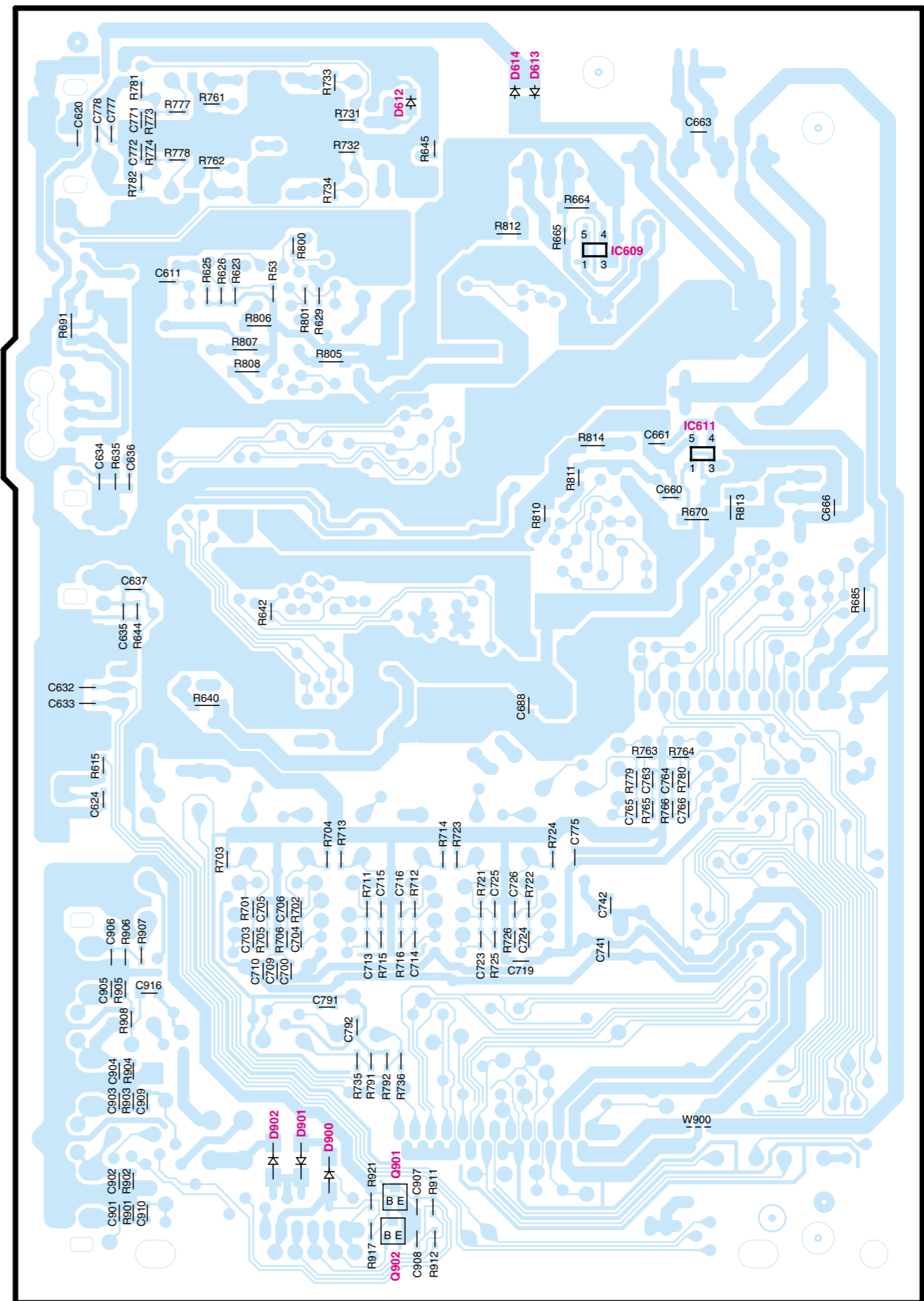

Refer to the schematic diagram for the value of resistors and capacitors.

PC BOARD(Component side view)

X09-6970-10 A/9
(J75-0055-01)

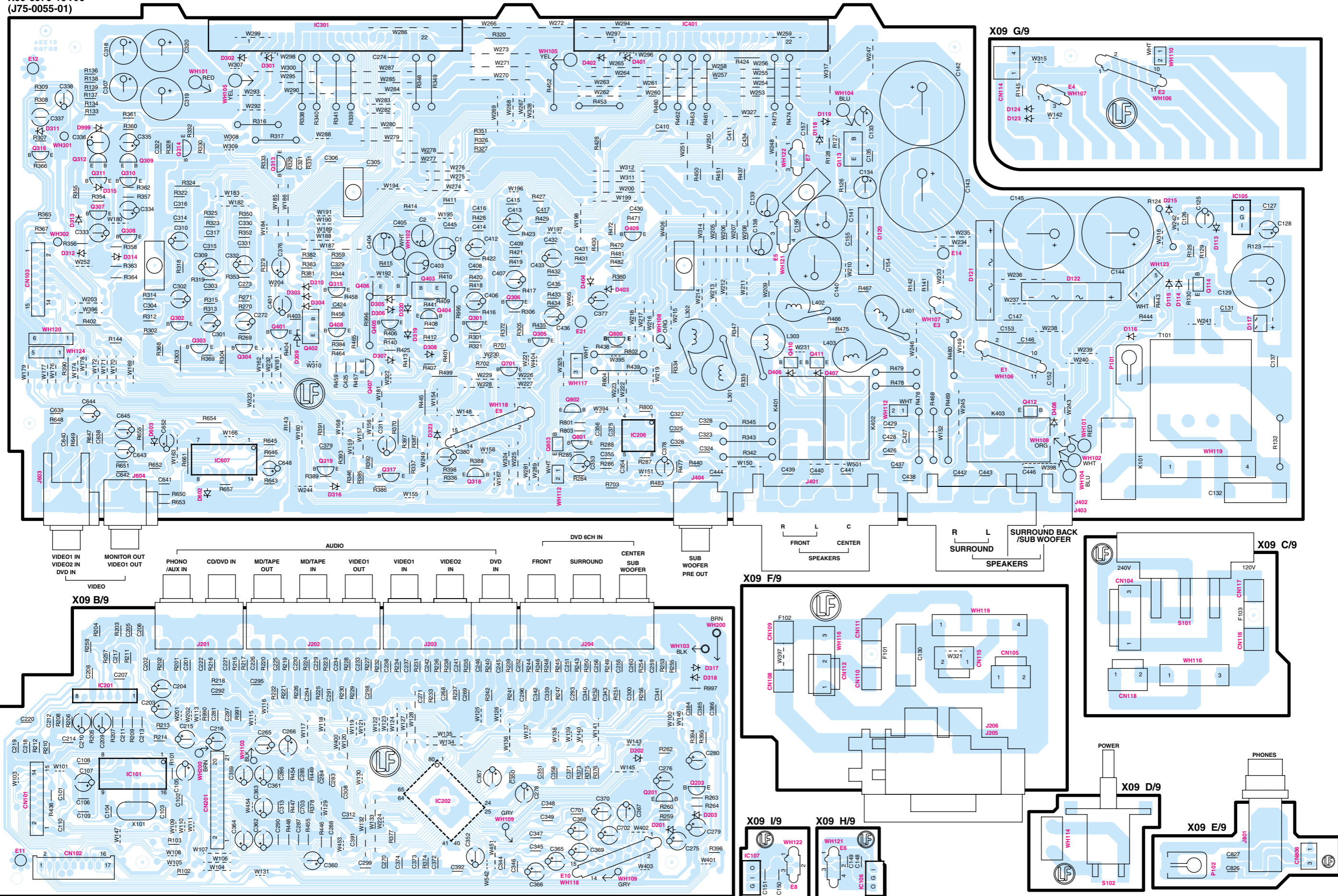

Refer to the schematic diagram for the value of resistors and capacitors.

PC BOARD(Component side view)

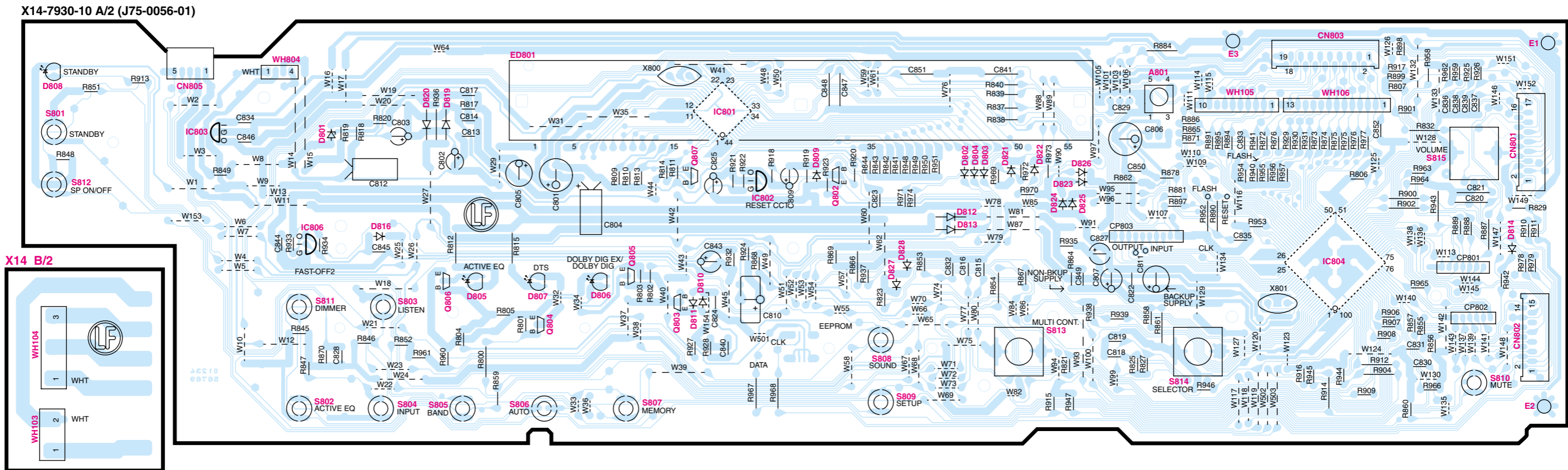

KRF-V5090D/V6090D/VR-905/906

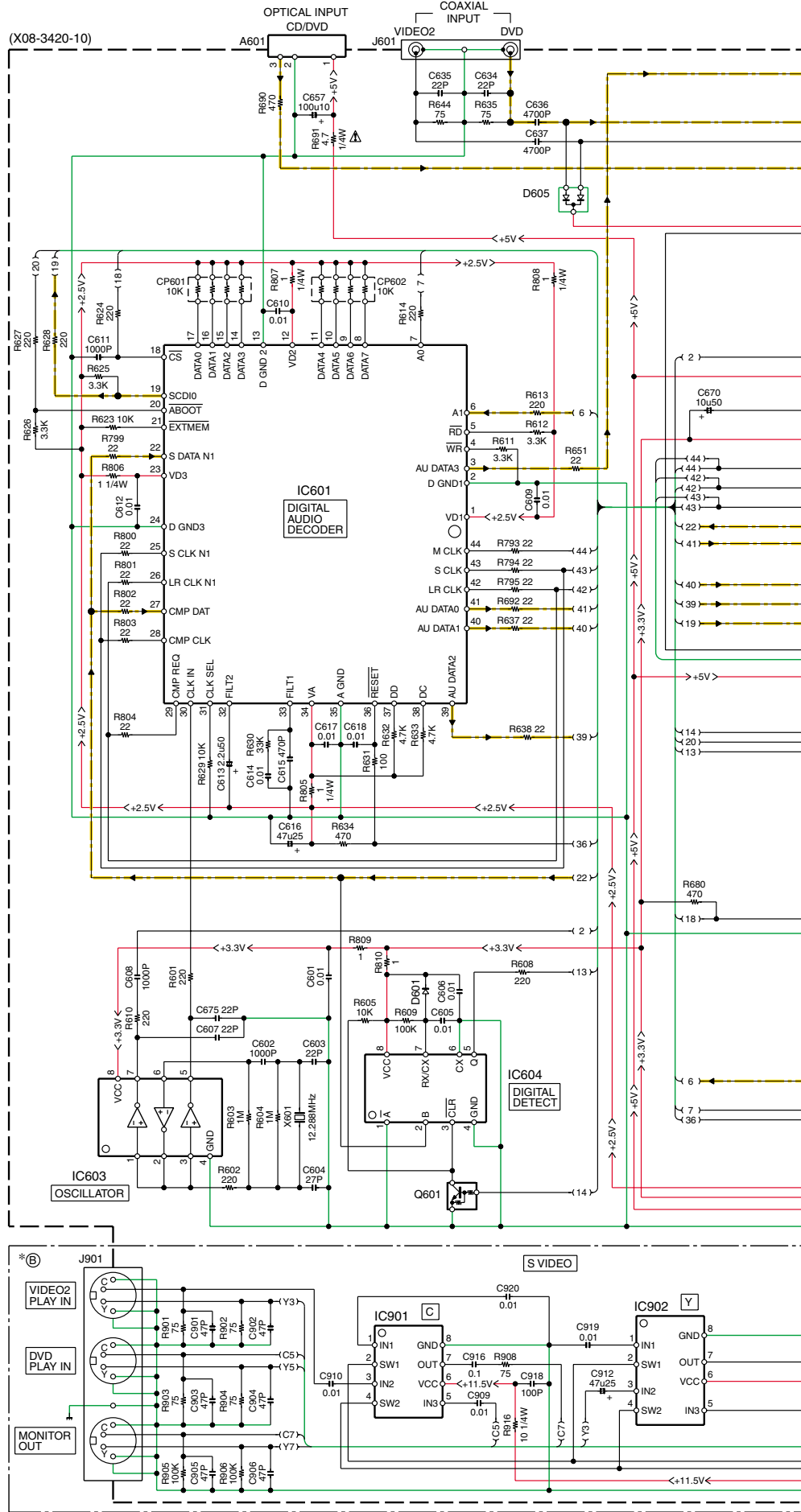

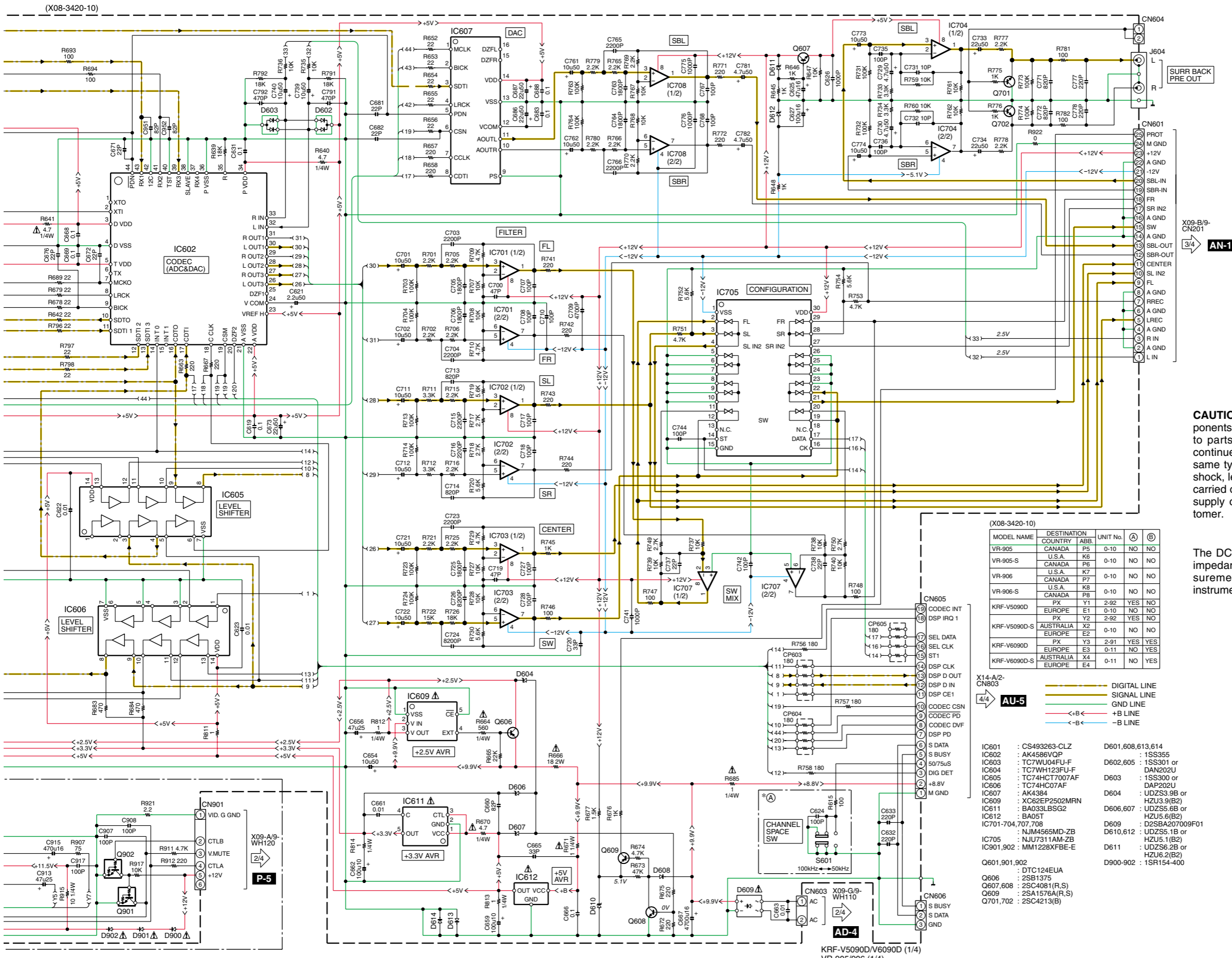

CAUTION: For continued safety, replace safety critical components only with manufacturer's recommended parts (refer to parts list). Δ indicates safety critical components. For continued protection against risk of fire, replace only with same type and rating fuse(s). To reduce the risk of electric shock, leakage-current or resistance measurements shall be carried out (exposed parts are acceptably insulated from the supply circuit) before the appliance is returned to the customer.

The DC voltage is an actual reading measured with a high impedance type voltmeter with no signal input. The measurement value may vary depending on the measuring instruments used or on the product.

(X08-3420-10)

MODEL NAME	COUNTRY	DESTINATION	UNIT No.	(A)	(B)
VR-905	CANADA	P5	0-10	NO	NO
VR-905-S	U.S.A.	K6	0-10	NO	NO
VR-906	CANADA	P6	0-10	NO	NO
VR-906-S	U.S.A.	K7	0-10	NO	NO
VR-906-S	CANADA	P7	0-10	NO	NO
KRF-V5090D	PX	Y1	2-92	YES	NO
KRF-V5090D-S	EUROPE	E1	0-10	NO	NO
KRF-V5090D-S	AUSTRALIA	X2	2-92	YES	NO
KRF-V6090D	EUROPE	E2	0-10	NO	NO
KRF-V6090D-S	PX	Y3	2-91	YES	YES
KRF-V6090D-S	EUROPE	E3	0-11	NO	YES
KRF-V6090D-S	AUSTRALIA	X4	0-11	NO	YES
KRF-V6090D-S	EUROPE	E4	0-11	NO	YES

X14-A/2-
CN803

AU-5

- DIGITAL LINE
- SIGNAL LINE
- GND LINE
- +B LINE
- B LINE

- IC601 : CS493263-CLZ
- IC602 : AK4586VOP
- IC603 : TC7WU04FU-F
- IC604 : TC7WH123FU-F
- IC605 : TC74HCT7007AF
- IC606 : TC74HC07AF
- IC607 : AK4384
- IC609 : XC62EP2502MRN
- IC611 : BA033LBSG2
- IC612 : BA05T
- IC701-704,707,708 : NJM4565MD-ZB
- IC705 : NJU7311AM-ZB
- IC901,902 : MM1228XFBE-E
- Q601,901,902 : DTC124EUA
- Q606 : 2SB1375
- Q607,608 : 2SC4081(R,S)
- Q609 : 2SA1576A(R,S)
- Q701,702 : 2SC4213(B)
- D601,608,613,614 : 1SS355
- D602,605 : 1SS301 or DAN202U
- D603 : 1SS300 or DAP202U
- D604 : UDZ53.9B or HZU3.9(B2)
- D606,607 : UDZ55.6B or HZU5.6(B2)
- D609 : D2SBA207009F01
- D610,612 : UDZ55.1B or HZU5.1(B2)
- D611 : UDZ56.2B or HZU6.2(B2)
- D900-902 : 1SR154-400

KRF-V5090D/V6090D/VR-905/906

(X09-6970-10) (A/9)

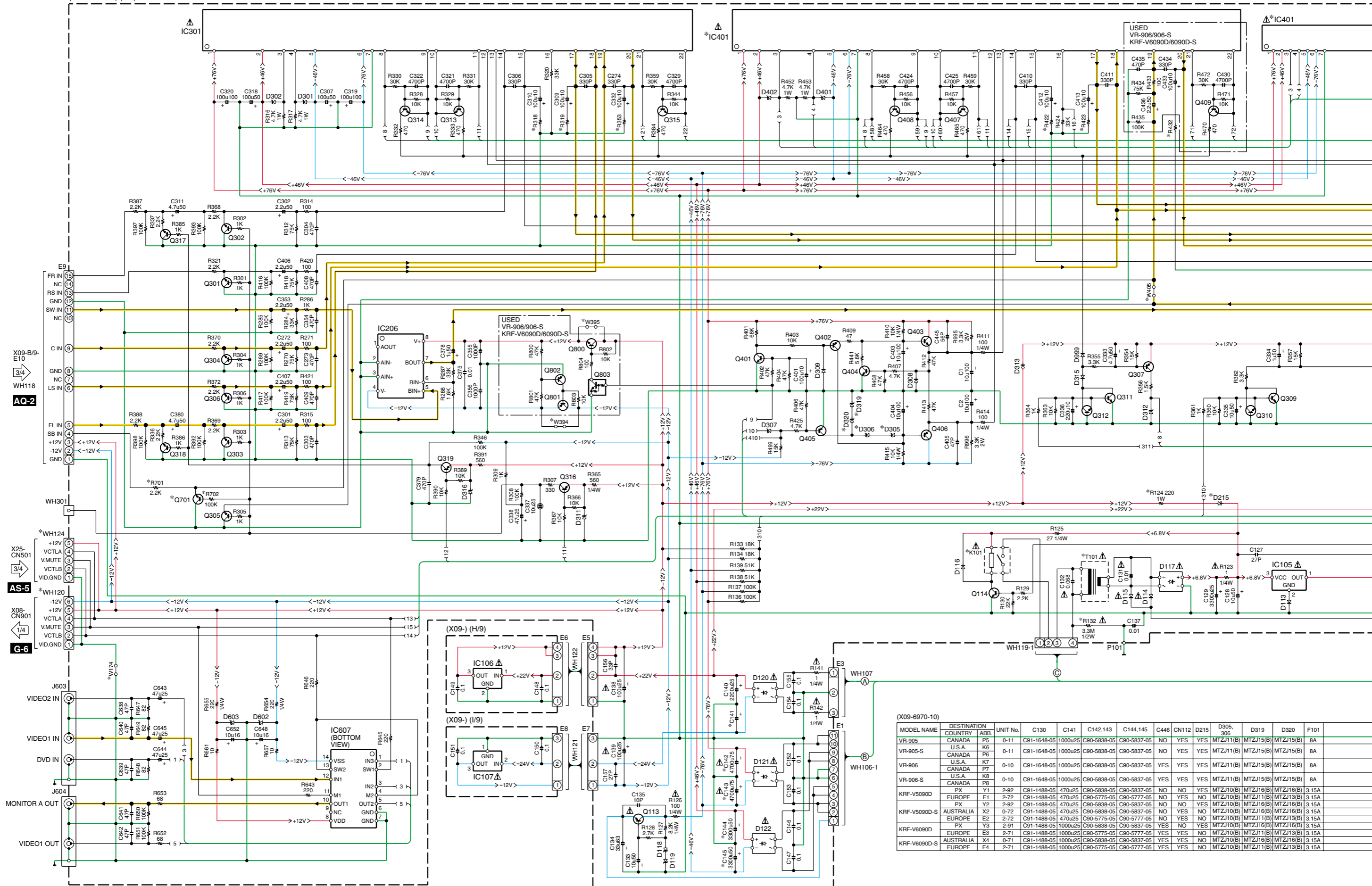

(X09-6970-10)

MODEL NAME	DESTINATION	ABB.	UNIT No.	C130	C141	C142,143	C144,145	C446	CN112	D215	D305, 306	D319	D320	F101
VR-905	CANADA	P5	0-11	C91-1648-05	1000u25	C90-5838-05	C90-5837-05	NO	YES	YES	MTZJ11(B)	MTZJ15(B)	MTZJ15(B)	8A
VR-905-S	U.S.A.	K6	0-11	C91-1648-05	1000u25	C90-5838-05	C90-5837-05	NO	YES	YES	MTZJ11(B)	MTZJ15(B)	MTZJ15(B)	8A
VR-906	U.S.A.	K7	0-10	C91-1648-05	1000u25	C90-5838-05	C90-5837-05	YES	YES	YES	MTZJ11(B)	MTZJ15(B)	MTZJ15(B)	8A
VR-906-S	CANADA	P8	0-10	C91-1648-05	1000u25	C90-5838-05	C90-5837-05	YES	YES	YES	MTZJ11(B)	MTZJ15(B)	MTZJ15(B)	8A
KRF-V5090D	EUROPE	E1	2-92	C91-1488-05	470u25	C90-5838-05	C90-5837-05	NO	NO	YES	MTZJ10(B)	MTZJ16(B)	MTZJ16(B)	3.15A
KRF-V5090D-S	EUROPE	E2	2-72	C91-1488-05	470u25	C90-5838-05	C90-5837-05	NO	NO	YES	MTZJ10(B)	MTZJ16(B)	MTZJ16(B)	3.15A
KRF-V5090D-S	AUSTRALIA	X2	0-72	C91-1488-05	470u25	C90-5838-05	C90-5837-05	NO	NO	YES	MTZJ10(B)	MTZJ16(B)	MTZJ16(B)	3.15A
KRF-V6090D	EUROPE	E3	2-91	C91-1488-05	1000u25	C90-5838-05	C90-5837-05	YES	NO	YES	MTZJ10(B)	MTZJ16(B)	MTZJ16(B)	3.15A
KRF-V6090D-S	EUROPE	E4	2-71	C91-1488-05	1000u25	C90-5838-05	C90-5837-05	YES	NO	YES	MTZJ10(B)	MTZJ16(B)	MTZJ16(B)	3.15A
KRF-V6090D-S	AUSTRALIA	X4	0-71	C91-1488-05	1000u25	C90-5838-05	C90-5837-05	YES	NO	YES	MTZJ10(B)	MTZJ16(B)	MTZJ16(B)	3.15A
KRF-V6090D-S	EUROPE	E4	2-71	C91-1488-05	1000u25	C90-5838-05	C90-5837-05	YES	NO	YES	MTZJ10(B)	MTZJ11(B)	MTZJ13(B)	3.15A

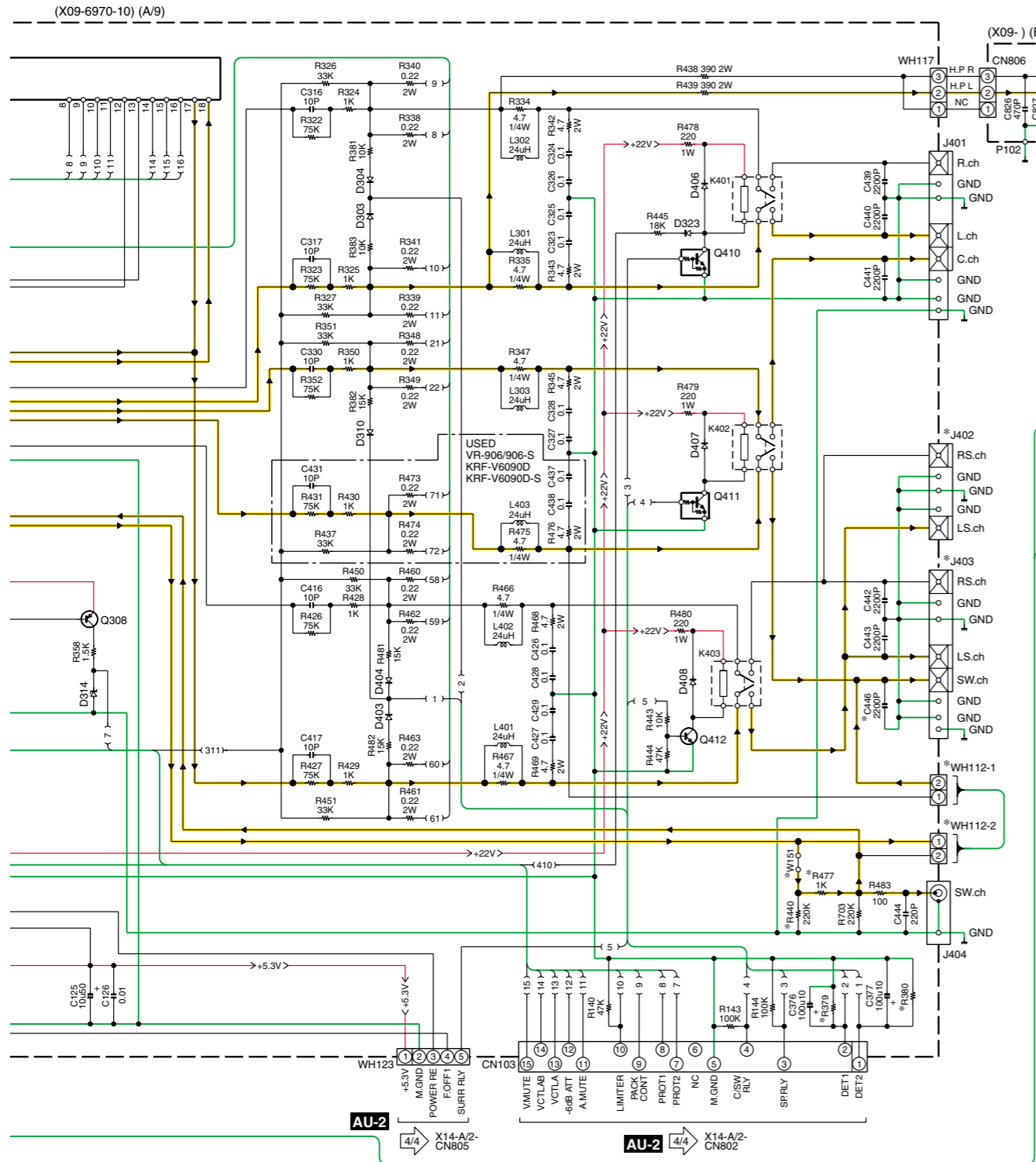

- IC105 : BA05T
- IC106 : KIA7812API-UP
- IC107 : KIA7912API-UP
- IC206 : NJM4565D-ZB
- IC301 : STK-413-220A-E
- IC401 : *
- IC607 : NJM2279D-ZB
- D113 : RB441Q-40
- D114-116,123,124,215,303,304,308-310,313,315,323,403,404,406-408,999
- D117 : 1SS133 or HSS104A
- D118 : S1ZB20(7101) or MTZJ16(B) or HZS16N(B2)
- D119,301,302,401,402 : MTZJ15(B) or HZS15N(B2)
- D120 : D2SBA207009F01
- D121,122 : D5SBA20-7003
- D305,306 : *
- D307,311,312,314,316 : MTZJ3.9(B) or HZS3.9N(B2)
- D319 : *
- D320 : *
- D602,603 : MTZJ5.6(B) or HZS5.6N(B2)
- Q113,406 : 2SB1640
- Q114,412 : 2SC1740S(Q,R) or 2SC2785S(F,E)
- Q301-306,317,318,701 : 2SC2878(B)
- Q307,308,316,319,405,801,802 : 2SA992(F,E)
- Q309-315,401,404,407-409,800 : 2SC1845(F,E)
- Q402 : 2SA1535A
- Q403 : 2SC3944A
- Q410,411,803 : DTC113ZSA

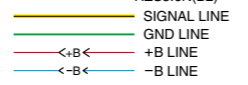

IC401	J205	J206	J402	J403	K101	Q701	R124	R132	R318,319,353,422,423	R379,380	R432	R440	R477	R701,702	T101	W151	W174	W321,397	W394,395	W405	WH112	WH120	WH124
STK-412-220A-E	E03-0396-05	NO	YES	NO	S76-0099-05	YES	YES	YES	680	1.2K	NO	NO	NO	YES	L07-2758-05	NO	NO	YES	YES	NO	YES	NO	NO
STK-412-220A-E	E03-0396-05	NO	NO	NO	S76-0099-05	YES	YES	YES	680	1.2K	NO	NO	NO	YES	L07-2758-05	NO	NO	YES	YES	NO	YES	NO	NO
STK-413-220A-E	E03-0396-05	NO	NO	YES	S76-0099-05	YES	YES	YES	680	1.2K	680	YES	YES	YES	L07-2758-05	YES	YES	YES	NO	NO	NO	NO	YES
STK-412-220A-E	E03-0396-05	NO	YES	NO	S76-0102-05	NO	YES	NO	680	1.2K	NO	NO	NO	NO	L07-2805-05	NO	YES	NO	YES	YES	YES	NO	YES
STK-412-220A-E	E03-0398-05	NO	YES	NO	S76-0102-05	NO	NO	NO	820	1.5K	NO	NO	NO	NO	L07-2758-05	NO	NO	NO	YES	YES	YES	NO	NO
STK-412-220A-E	E03-0396-05	NO	YES	NO	S76-0102-05	NO	YES	NO	680	1.2K	NO	NO	NO	NO	L07-2805-05	NO	YES	NO	YES	YES	YES	NO	YES
STK-412-220A-E	NO	YES	YES	NO	S76-0102-05	NO	NO	NO	680	1.2K	NO	NO	NO	NO	L07-2758-05	NO	NO	NO	YES	YES	YES	YES	NO
STK-412-220A-E	E03-0398-05	NO	YES	NO	S76-0102-05	NO	NO	NO	820	1.5K	NO	NO	NO	NO	L07-2758-05	NO	NO	NO	NO	YES	YES	NO	NO
STK-413-220A-E	E03-0396-05	NO	NO	YES	S76-0102-05	YES	YES	NO	680	1.2K	680	YES	YES	YES	L07-2805-05	YES	YES	NO	NO	NO	NO	NO	YES
STK-413-220A-E	E03-0398-05	NO	NO	YES	S76-0102-05	YES	NO	NO	820	1.5K	820	YES	YES	YES	L07-2758-05	YES	YES	NO	NO	NO	NO	NO	YES
STK-413-220A-E	NO	YES	NO	YES	S76-0102-05	YES	NO	NO	680	1.2K	680	YES	YES	YES	L07-2758-05	YES	YES	NO	NO	NO	NO	NO	YES
STK-413-220A-E	E03-0398-05	NO	NO	YES	S76-0102-05	YES	NO	NO	820	1.5K	820	YES	YES	YES	L07-2758-05	YES	YES	NO	NO	NO	NO	NO	YES

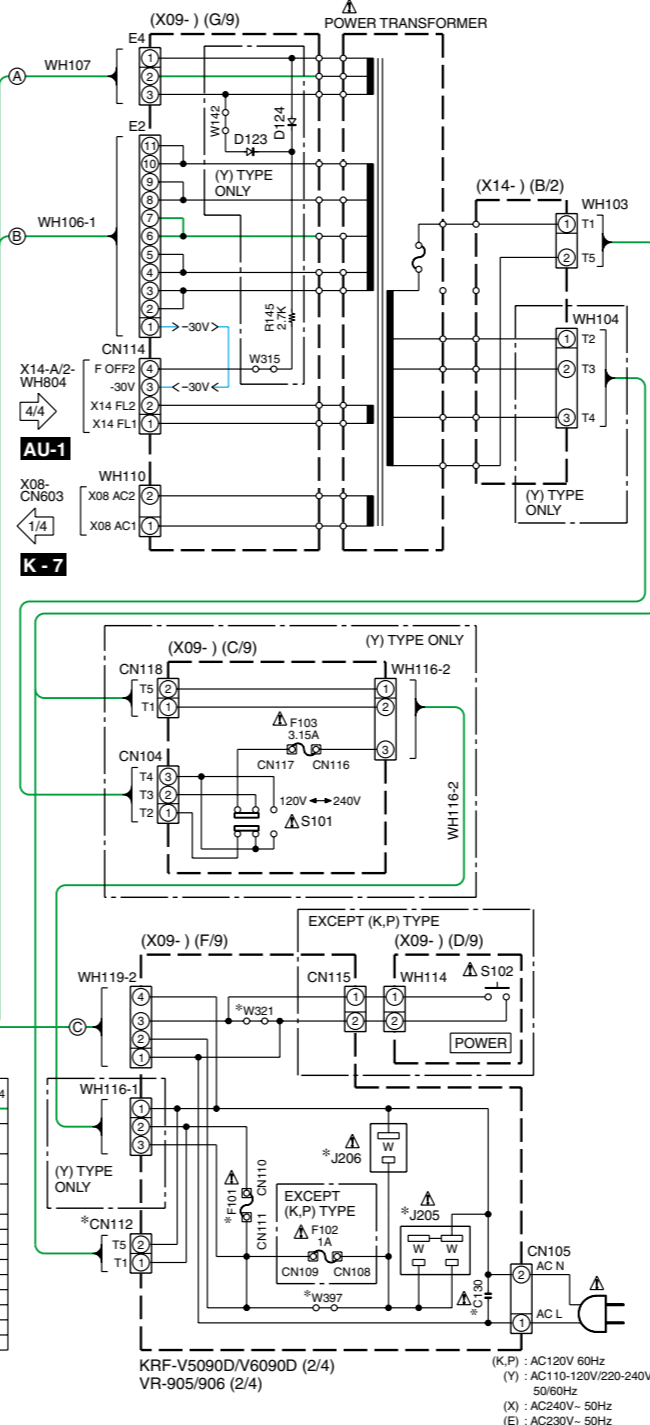

CAUTION: For continued safety, replace safety critical components only with manufacturer's recommended parts (refer to parts list). Δ indicates safety critical components. For continued protection against risk of fire, replace only with same type and rating fuse(s). To reduce the risk of electric shock, leakage-current or resistance measurements shall be carried out (exposed parts are acceptably insulated from the supply circuit) before the appliance is returned to the customer.

The DC voltage is an actual reading measured with a high impedance type voltmeter with no signal input. The measurement value may vary depending on the measuring instruments used or on the product.

KRF-V5090D/V6090D/VR-905/906

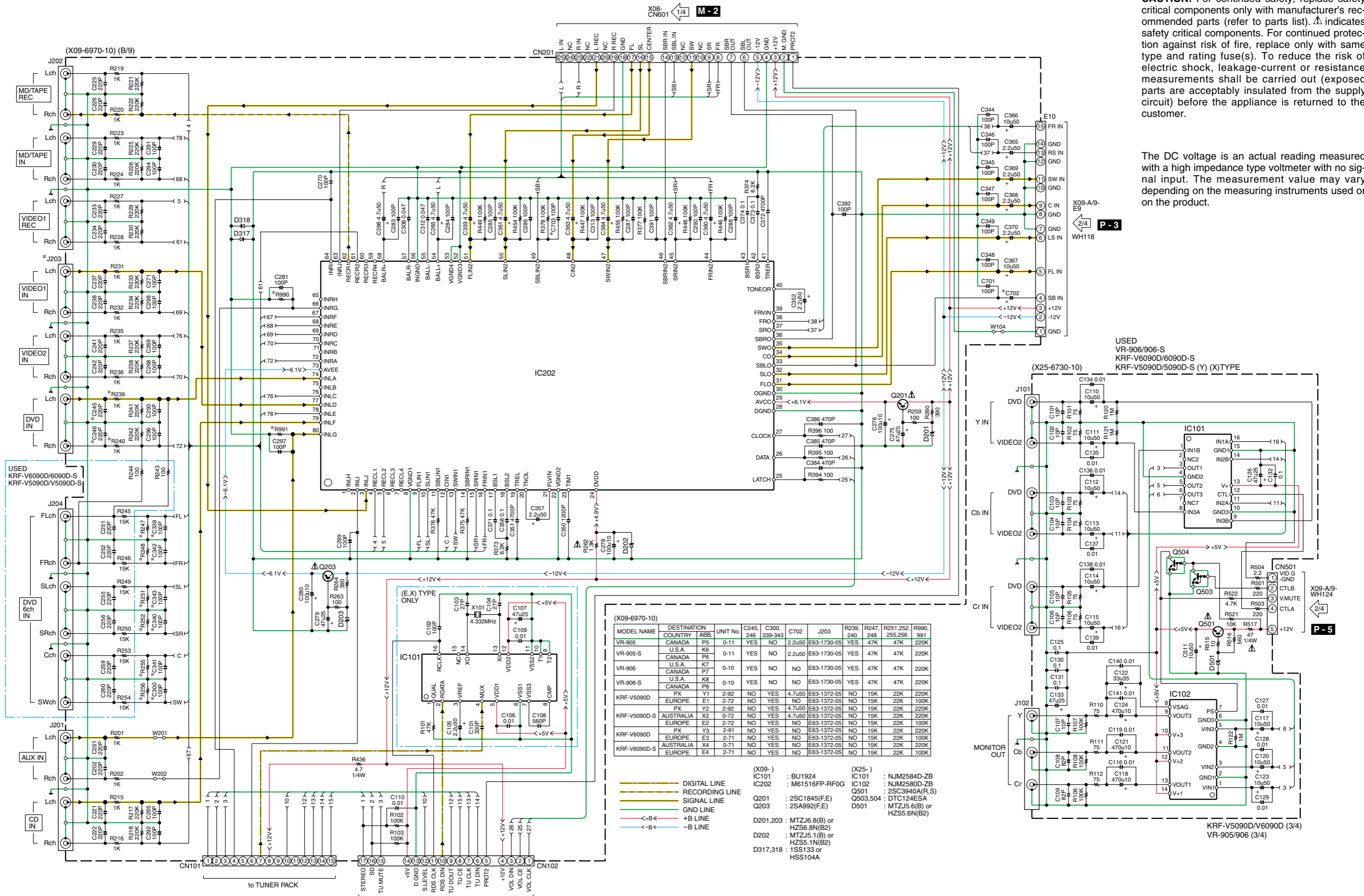

CAUTION: For continued safety, replace safety critical components only with manufacturer's recommended parts (refer to parts list). Δ indicates safety critical components. For continued protection against risk of fire, replace only with same type and rating fuse(s). To reduce the risk of electric shock, leakage-current or resistance measurements shall be carried out (exposed parts are acceptably insulated from the supply circuit) before the appliance is returned to the customer.

The DC voltage is an actual reading measured with a high impedance type voltmeter with no signal input. The measurement value may vary depending on the measuring instruments used or on the product.

MODEL NAME	DESTINATION COUNTRY	ABB.	UNIT No.	C245, 246	C300, 339-343	C702	J203	R239, 240	R247, 248	R251, 252, 255, 256	R990, 991
VR-905	CANADA	P5	0-11	YES	NO	2.2u50	E63-1730-05	YES	47K	47K	220K
VR-905-S	U.S.A.	K6	0-11	YES	NO	2.2u50	E63-1730-05	YES	47K	47K	220K
VR-906	CANADA	P7	0-10	YES	NO	NO	E63-1730-05	YES	47K	47K	220K
VR-906-S	U.S.A.	K8	0-10	YES	NO	NO	E63-1730-05	YES	47K	47K	220K
KRF-V5090D	EUROPE	E1	2-72	NO	YES	4.7u50	E63-1372-05	NO	15K	22K	100K
KRF-V5090D-S	EUROPE	E2	2-72	NO	YES	4.7u50	E63-1372-05	NO	15K	22K	100K
KRF-V6090D	EUROPE	E3	2-71	NO	YES	NO	E63-1372-05	NO	15K	22K	100K
KRF-V6090D-S	EUROPE	E4	2-71	NO	YES	NO	E63-1372-05	NO	15K	22K	100K

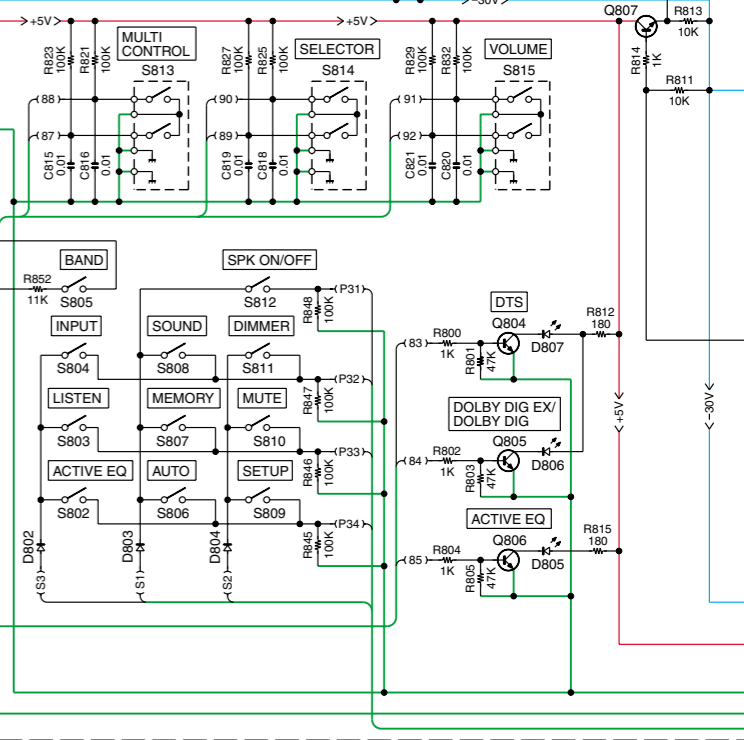
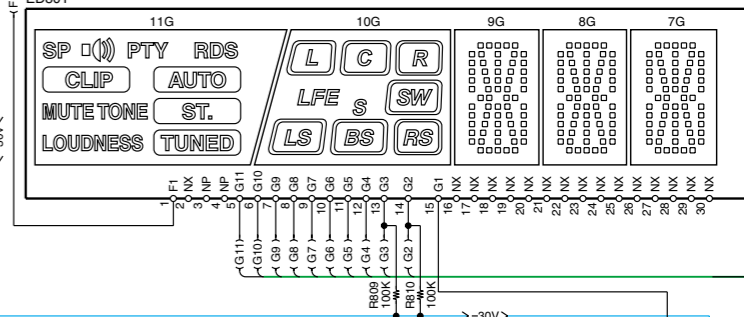
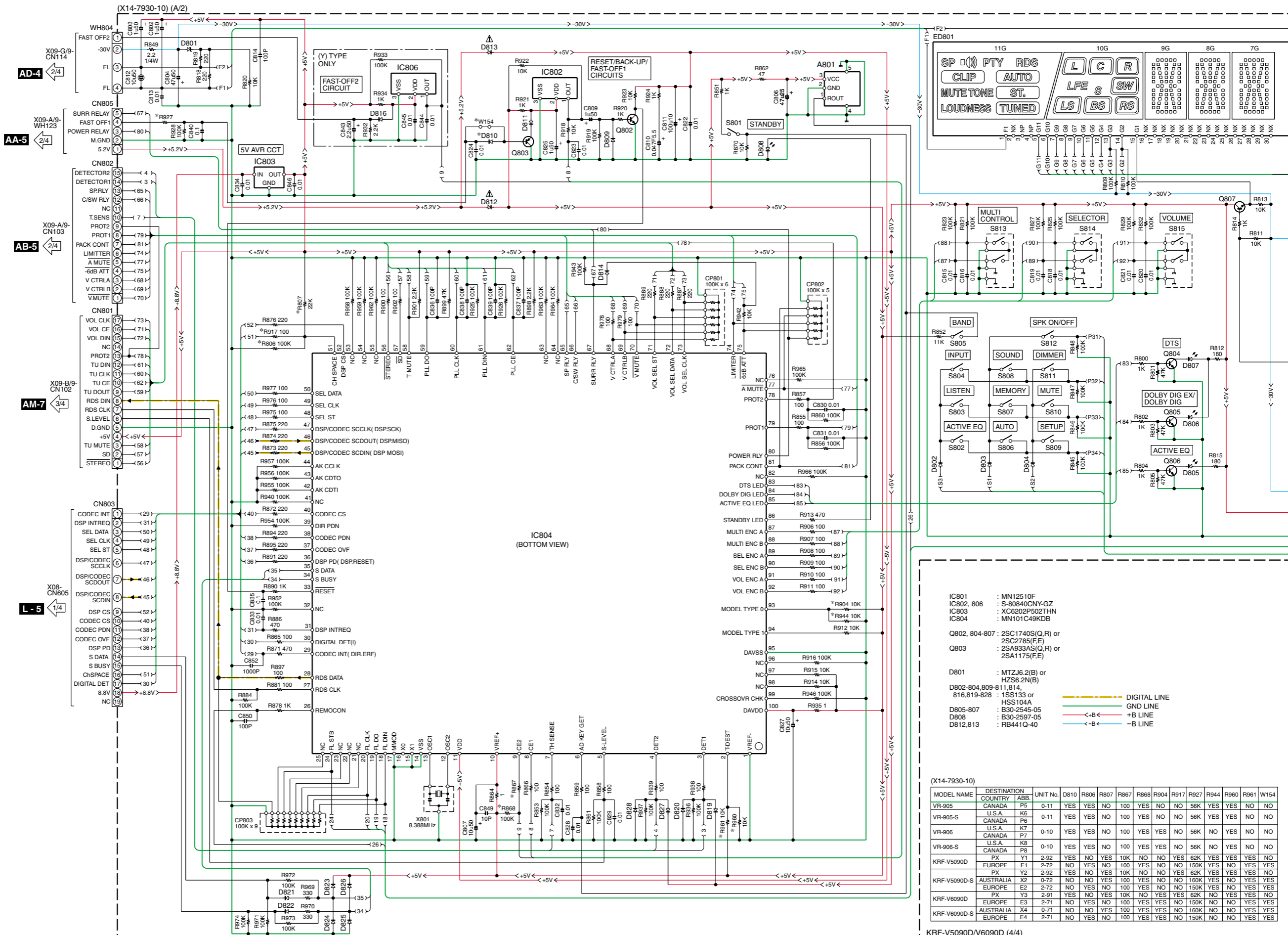

- IC801 : MN12510F
- IC802, 806 : S-80840CNY-GZ
- IC803 : XC6202P502THN
- IC804 : MN101C49KDB
- Q802, 804-807 : 2SC1740S(Q,R) or 2SC2785(F,E)
- Q803 : 2SA933AS(Q,R) or 2SA1175(F,E)
- D801 : MTZJ6.2(B) or HZS6.2N(B)
- D802-804, 809-811, 814, 816, 819-828 : 1SS133 or HSS104A
- D805-807 : B30-2545-05
- D808 : B30-2597-05
- D812, 813 : RB441Q-40

(X14-7930-10)

MODEL NAME	DESTINATION COUNTRY	ABB.	UNIT No.	D810	R806	R807	R867	R868	R904	R917	R927	R944	R960	R961	W154
VR-905	CANADA	P5	0-11	YES	YES	NO	100	YES	NO	NO	56K	YES	YES	NO	NO
VR-905-S	U.S.A.	K6	0-11	YES	NO	100	YES	NO	NO	NO	56K	YES	YES	NO	NO
VR-906	CANADA	P6	0-10	YES	YES	NO	100	YES	YES	NO	56K	NO	YES	NO	NO
VR-906-S	U.S.A.	K7	0-10	YES	YES	NO	100	YES	YES	NO	56K	NO	YES	NO	NO
VR-906-S	CANADA	P8	0-10	YES	YES	NO	100	YES	YES	NO	56K	NO	YES	NO	NO
KRF-V5090D	EUROPE	E1	2-92	YES	NO	YES	10K	NO	NO	YES	62K	YES	YES	YES	NO
KRF-V5090D-S	U.S.A.	K8	2-92	YES	NO	YES	10K	NO	NO	YES	62K	YES	YES	YES	NO
KRF-V5090D-S	EUROPE	E2	2-72	NO	YES	NO	100	YES	NO	NO	150K	YES	NO	YES	YES
KRF-V6090D	EUROPE	E3	2-91	YES	NO	YES	10K	NO	NO	YES	62K	NO	YES	YES	NO
KRF-V6090D-S	U.S.A.	K4	2-71	NO	YES	NO	100	YES	YES	NO	150K	NO	NO	YES	YES
KRF-V6090D-S	EUROPE	E4	2-71	NO	YES	NO	100	YES	YES	NO	150K	NO	NO	YES	YES

KRF-V5090D/V6090D (4/4)
VR-905/906 (4/4)

KRF-V5090D/V6090D/VR-905/906

(X14-7930-10) (A/2)

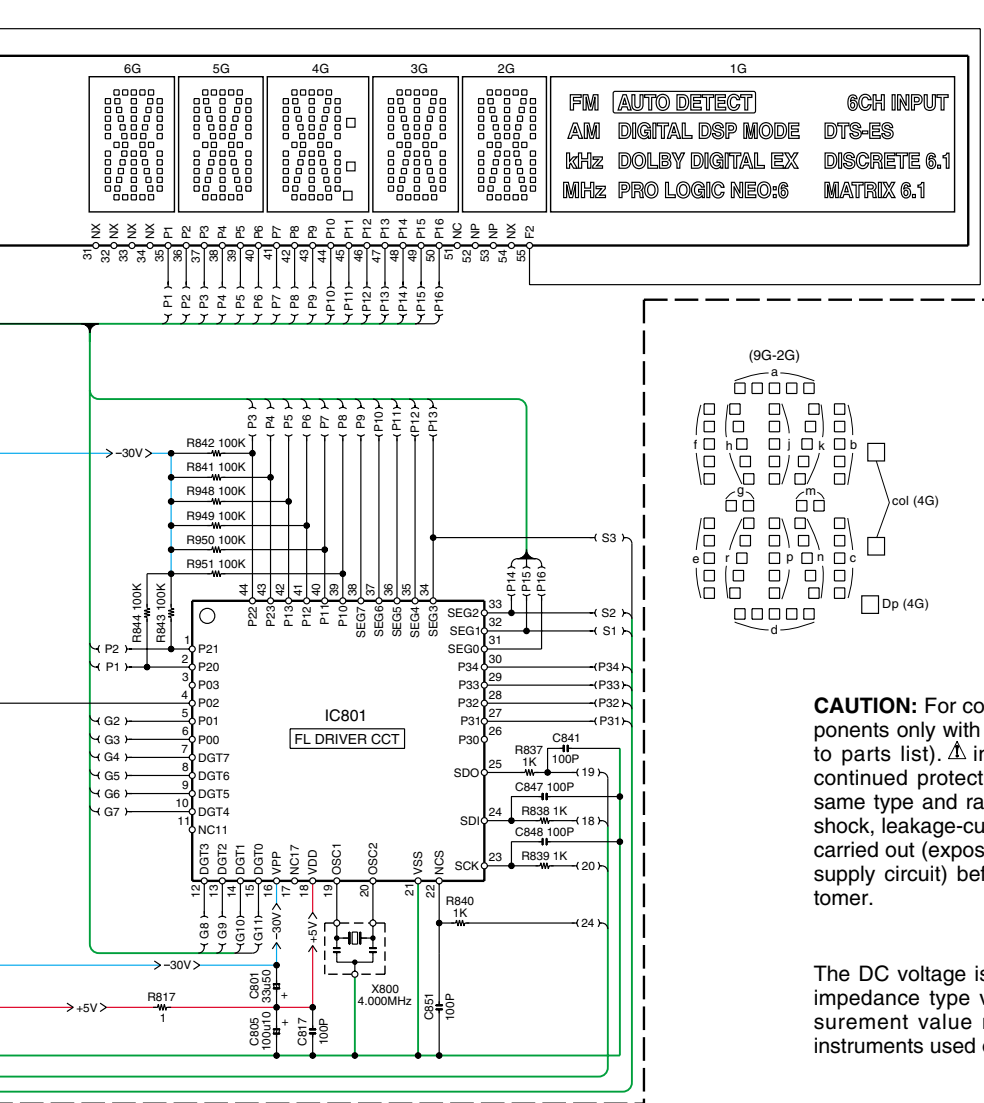

CAUTION: For continued safety, replace safety critical components only with manufacturer's recommended parts (refer to parts list). Δ indicates safety critical components. For continued protection against risk of fire, replace only with same type and rating fuse(s). To reduce the risk of electric shock, leakage-current or resistance measurements shall be carried out (exposed parts are acceptably insulated from the supply circuit) before the appliance is returned to the customer.

The DC voltage is an actual reading measured with a high impedance type voltmeter with no signal input. The measurement value may vary depending on the measuring instruments used or on the product.

11-MT-143GNK

	11G	10G	9G	8G	7G	6G	5G	4G	3G	2G	1G
P1	SP Δ (M)	L	a	a	a	a	a	a	a	a	FM
P2	CLIP	C	j	j	j	j	j	j	j	j	AM
P3	MUTE	R	h	h	h	h	h	h	h	h	kHz
P4	TONES	LFE	k	k	k	k	k	k	k	k	MHz
P5	LOUDNESS	SW	b	b	b	b	b	b	b	b	(AUTO DETECT)
P6	PTY	LS	f	f	f	f	f	f	f	f	DIGITAL
P7	RDS	SS	g	g	g	g	g	g	g	g	6CH INPUT
P8	(AUTO)	BS	m	m	m	m	m	m	m	m	DSP MODE
P9	ST.	AS	c	c	c	c	c	c	c	c	DOLBY DIGITAL
P10	(TUNED)	(L)	e	e	e	e	e	e	e	e	EX
P11	-	(C)	r	r	r	r	r	r	r	r	PRO LOGIC
P12	-	(R)	n	n	n	n	n	n	n	n	NEO-6
P13	-	(SW)	p	p	p	p	p	p	p	p	DTS
P14	-	(LS)	d	d	d	d	d	d	d	d	-ES
P15	-	(BS)	-	-	-	-	-	col	-	-	DISCRETE 6.1
P16	-	(RS)	-	-	-	-	-	-	Dp	-	MATRIX 6.1

11MT129GNK

	11G	10G	9G	8G	7G	6G	5G	4G	3G	2G	1G
P1	SP Δ (M)	L	a	a	a	a	a	a	a	a	FM
P2	(A)	C	j	j	j	j	j	j	j	j	AM
P3	(B)	R	h	h	h	h	h	h	h	h	kHz
P4	MUTE	SL	k	k	k	k	k	k	k	k	MHz
P5	(CLIP)	S	b	b	b	b	b	b	b	b	(AUTO)
P6	CINEMA EQ.	SR	f	f	f	f	f	f	f	f	(MEMO)
P7	-	LFE	g	g	g	g	g	g	g	g	(ST.)
P8	-	SW	m	m	m	m	m	m	m	m	(TUNED)
P9	RDS	(L)	c	c	c	c	c	c	c	c	(AUTO DETECT)
P10	PTY	(C)	e	e	e	e	e	e	e	e	DTS
P11	96kHz	(R)	r	r	r	r	r	r	r	r	DOLBY DIGITAL
P12	TONES	(SL)	n	n	n	n	n	n	n	n	PRO LOGIC
P13	LOUDNESS	(S)	p	p	p	p	p	p	p	p	DIGITAL
P14	-	(SR)	d	d	d	d	d	d	d	d	6CH INPUT
P15	-	(SW)	-	-	-	-	-	col	-	-	DSP
P16	-	-	-	-	-	-	-	-	Dp	-	STEREO

KRF-V5090D/V6090D/VR-905/906

EXPLODED VIEW (UNIT)

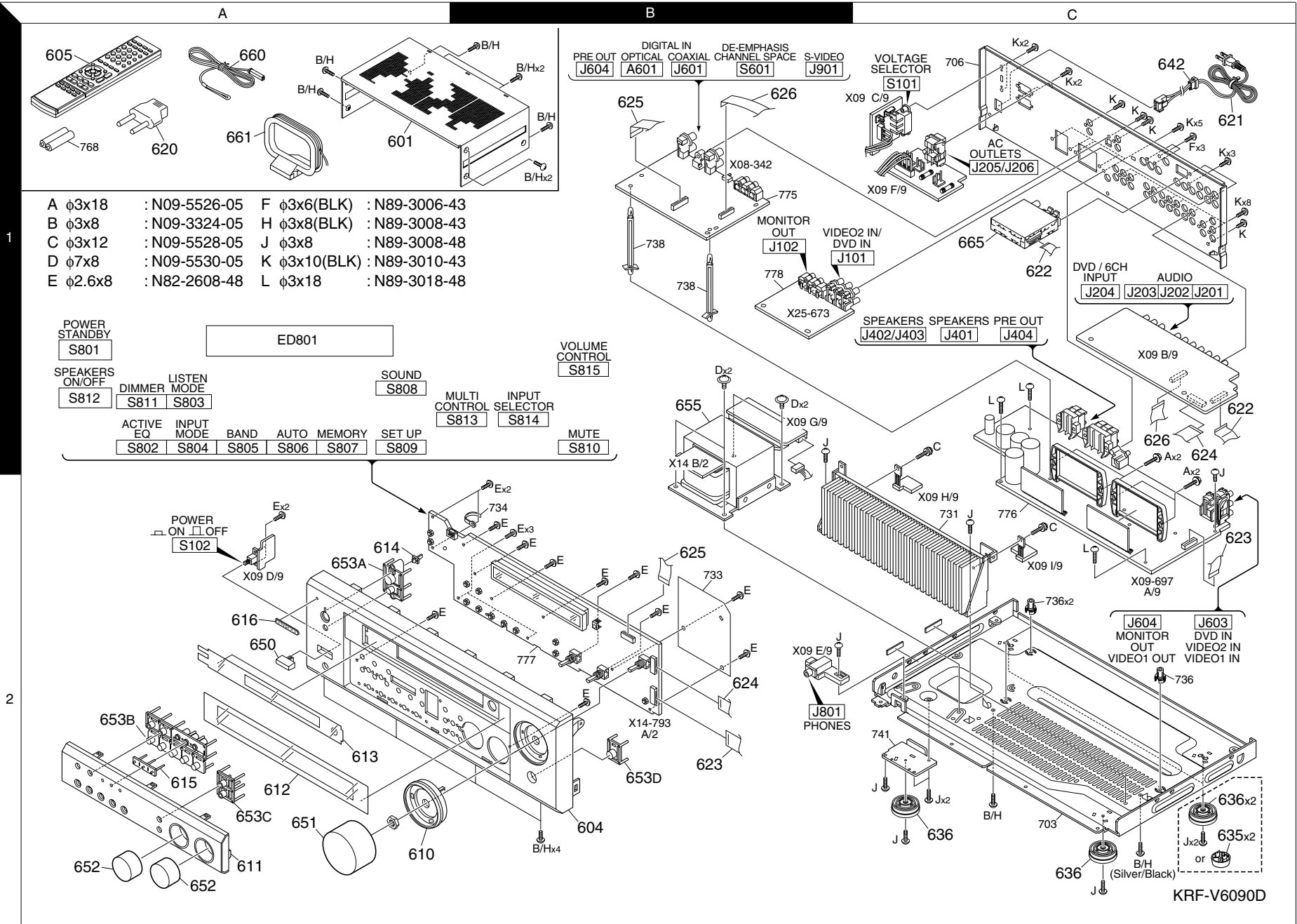

Parts with exploded numbers larger than 700 are not supplied.

* New Parts
Parts without **Parts No.** are not supplied.
Les articles non mentionnés dans le **Parts No.** ne sont pas fournis.
Teile ohne **Parts No.** werden nicht geliefert.

①

Ref. No	Add-ress	New Parts	Parts No.	Description	Desti-nation	Re-marks
KRF-V5090D/V6090D, VR-905/906						
601	1A	*	A01-3944-01	METALLIC CABINET	E3	
601	1A	*	A01-3944-01	METALLIC CABINET	K7P7Y3	
601	1A	*	A01-3944-01	METALLIC CABINET	Y1E1P5	
601	1A	*	A01-3945-01	METALLIC CABINET	E4	
601	1A	*	A01-3945-01	METALLIC CABINET	K6P6Y2	
601	1A	*	A01-3945-01	METALLIC CABINET	K8P8X4	
601	1A	*	A01-3945-01	METALLIC CABINET	X2E2	
604	2B	*	A60-2379-01	PANEL	Y1E1	
604	2B	*	A60-2379-01	PANEL	Y3E3	
604	2B	*	A60-2380-01	PANEL	X4E4	
604	2B	*	A60-2380-01	PANEL	Y2X2E2	
604	2B	*	A60-2405-01	PANEL	K7P7	
604	2B	*	A60-2405-01	PANEL	P5	
604	2B	*	A60-2406-01	PANEL	K6P6	
604	2B	*	A60-2406-01	PANEL	K8P8	
605	1A	*	A70-1669-05	REMOTE CONTROLLER ASSY	KPY	
605	1A	*	A70-1670-05	REMOTE CONTROLLER ASSY	EX	
-	-	*	B60-5529-00	INSTRUCTION MANUAL(EN)	KPY	
-	-	*	B60-5530-00	INSTRUCTION MANUAL(FR)	P	
-	-	*	B60-5531-00	INSTRUCTION MANUAL(TC)	Y	
-	-	*	B60-5532-00	INSTRUCTION MANUAL(6-LN)	E	
-	-	*	B60-5533-00	INSTRUCTION MANUAL(EN)	X	
610	2A	*	B07-2685-03	ESCUTCHEON	E4	
610	2A	*	B07-2685-03	ESCUTCHEON	K6P6Y2	
610	2A	*	B07-2685-03	ESCUTCHEON	K8P8X4	
610	2A	*	B07-2685-03	ESCUTCHEON	X2E2	
610	2A	*	B07-2688-03	ESCUTCHEON	E3	
610	2A	*	B07-2688-03	ESCUTCHEON	K7P7Y3	
610	2A	*	B07-2688-03	ESCUTCHEON	Y1E1P5	
611	2A	*	B07-2722-01	ESCUTCHEON	E3	
611	2A	*	B07-2722-01	ESCUTCHEON	K7P7Y3	
611	2A	*	B07-2722-01	ESCUTCHEON	Y1E1P5	
611	2A	*	B07-2723-01	ESCUTCHEON	E4	
611	2A	*	B07-2723-01	ESCUTCHEON	K6P6Y2	
611	2A	*	B07-2723-01	ESCUTCHEON	K8P8X4	
611	2A	*	B07-2723-01	ESCUTCHEON	X2E2	
612	2A	*	B10-5552-02	FRONT GLASS	K7P7	
612	2A	*	B10-5553-02	FRONT GLASS	K8P8	
612	2A	*	B10-5554-02	FRONT GLASS	Y3	
612	2A	*	B10-5556-02	FRONT GLASS	X4E4	
612	2A	*	B10-5557-02	FRONT GLASS	E3	
612	2A	*	B10-5558-02	FRONT GLASS	K6P6P5	
612	2A	*	B10-5559-02	FRONT GLASS	Y1	
612	2A	*	B10-5560-02	FRONT GLASS	Y2	
612	2A	*	B10-5561-02	FRONT GLASS	X2E2	
612	2A	*	B10-5562-02	FRONT GLASS	E1	
613	2A	*	B11-1568-13	COLOR FILTER		
614	2A	*	B12-0482-04	INDICATOR	STANDBY	
615	2A	*	B12-0483-04	INDICATOR		
616	2A	*	B43-0336-04	BADGE		
△ 620	1A	*	E03-0508-05	AC PLUG ADAPTER	Y	
△ 621	1C	*	E30-2842-05	AC POWER CORD	E	

L : Scandinavia K : USA P : Canada R : Mexico C : China I : Malaysia
Y : PX(Far East,Hawaii) T : England E : Europe G : Germany V : China(Shanghai)
Y : AAFES(Europe) X : Australia Q : Russia H : Korea M : Other Areas △ indicates safety critical components.

* New Parts
Parts without **Parts No.** are not supplied.
Les articles non mentionnés dans le **Parts No.** ne sont pas fournis.
Teile ohne **Parts No.** werden nicht geliefert.

②

Ref. No	Add-ress	New Parts	Parts No.	Description	Desti-nation	Re-marks
△ 621	1C	*	E30-2941-05	AC POWER CORD	KP	
△ 621	1C	*	E30-7313-05	AC POWER CORD	Y	
△ 621	1C	*	E30-7330-05	AC POWER CORD	X	
622	1C	*	E35-2643-05	FLAT CABLE		
623	2B,2C	*	E35-2792-05	FLAT CABLE		
624	2B,1C	*	E35-3306-15	FLAT CABLE		
625	1B,2B	*	E35-3468-05	FLAT CABLE		
626	1C	*	E35-3632-05	FLAT CABLE		
-	-	*	H10-7929-01	POLYSTYRENE FOAMED FIXTURE		
-	-	*	H10-7930-01	POLYSTYRENE FOAMED FIXTURE		
-	-	*	H25-0232-04	PROTECTION BAG (235X350X0.03)		
-	-	*	H25-0391-04	PROTECTION BAG		
-	-	*	H50-5014-04	ITEM CARTON CASE	K7P7	
-	-	*	H50-5015-04	ITEM CARTON CASE	K8P8	
-	-	*	H50-5016-04	ITEM CARTON CASE	Y3	
-	-	*	H50-5018-04	ITEM CARTON CASE	X4	
-	-	*	H50-5019-04	ITEM CARTON CASE	E3	
-	-	*	H50-5020-04	ITEM CARTON CASE	E4	
-	-	*	H50-5021-04	ITEM CARTON CASE	K6P6	
-	-	*	H50-5022-04	ITEM CARTON CASE	Y1	
-	-	*	H50-5023-04	ITEM CARTON CASE	Y2	
-	-	*	H50-5024-04	ITEM CARTON CASE	X2	
-	-	*	H50-5025-04	ITEM CARTON CASE	E1	
-	-	*	H50-5026-04	ITEM CARTON CASE	E2	
-	-	*	H50-5036-04	ITEM CARTON CASE	P5	
-	-	*	J61-0307-05	WIRE BAND		
635	2C	*	J02-1013-05	FOOT	KPYX	
636	2C	*	J02-1464-03	FOOT		
△ 642	1C	*	J42-0083-05	POWER CORD BUSHING		
650	2A	*	K27-2525-14	BUTTON KNOB	Y1E1	
650	2A	*	K27-2525-14	BUTTON KNOB	Y3E3	
650	2A	*	K27-2526-14	BUTTON KNOB	X4E4	
650	2A	*	K27-2526-14	BUTTON KNOB	Y2X2E2	
651	2A	*	K29-8350-14	BUTTON KNOB	E3	
651	2A	*	K29-8350-14	KNOB	K7P7Y3	
651	2A	*	K29-8350-14	KNOB	Y1E1P5	
651	2A	*	K29-8351-04	KNOB	E4	
651	2A	*	K29-8351-04	KNOB	K6P6Y2	
651	2A	*	K29-8351-04	KNOB	K8P8X4	
651	2A	*	K29-8351-04	KNOB	X2E2	
652	2A	*	K29-8352-14	KNOB	E3	
652	2A	*	K29-8352-14	KNOB	K7P7Y3	
652	2A	*	K29-8352-14	KNOB	Y1E1P5	
652	2A	*	K29-8353-04	KNOB	E4	
652	2A	*	K29-8353-04	KNOB	K6P6Y2	
652	2A	*	K29-8353-04	KNOB	K8P8X4	
652	2A	*	K29-8353-04	KNOB	X2E2	
653	2A,2B	*	K29-8354-01	KNOB	E3	
653	2A,2B	*	K29-8354-01	KNOB	K7P7Y3	
653	2A,2B	*	K29-8354-01	KNOB	Y1E1P5	
653	2A,2B	*	K29-8355-01	KNOB	E4	
653	2A,2B	*	K29-8355-01	KNOB	K6P6Y2	
653	2A,2B	*	K29-8355-01	KNOB	K8P8X4	
653	2A,2B	*	K29-8355-01	KNOB	X2E2	

L : Scandinavia K : USA P : Canada R : Mexico C : China I : Malaysia
Y : PX(Far East,Hawaii) T : England E : Europe G : Germany V : China(Shanghai)
Y : AAFES(Europe) X : Australia Q : Russia H : Korea M : Other Areas △ indicates safety critical components.

PARTS LIST

KRF-V5090D/V6090D/VR-905/906

* New Parts

Parts without **Parts No.** are not supplied.
Les articles non mentionnés dans le **Parts No.** ne sont pas fournis.
Teile ohne **Parts No.** werden nicht geliefert.

③

* New Parts

Parts without **Parts No.** are not supplied.
Les articles non mentionnés dans le **Parts No.** ne sont pas fournis.
Teile ohne **Parts No.** werden nicht geliefert.

④

Ref. No	Address	New Parts	Parts No.	Description	Destination	Remarks
△ 655	1B	*	L07-3306-05	POWER TRANSFORMER	KP	
△ 655	1B	*	L07-3307-05	POWER TRANSFORMER	Y	
△ 655	1B	*	L07-3308-05	POWER TRANSFORMER	X	
△ 655	1B	*	L07-3309-05	POWER TRANSFORMER	E	
E			N82-2608-48	BINDING HEAD TAPTITE SCREW		
J			N89-3008-48	BINDING HEAD TAPTITE SCREW		
L			N89-3018-48	BINDING HEAD TAPTITE SCREW		
660	1A		T90-0855-05	LEAD WIRE ANTENNA	YXE	
660	1A		T90-0905-05	LEAD WIRE ANTENNA	KP	
661	1A		T90-0893-05	LOOP ANTENNA	EX	
665	1C		W02-2970-15	TUNER ASSY	KP	
665	1C		W02-2971-05	TUNER ASSY	Y	
665	1C		W02-2972-05	TUNER ASSY	EX	
SURROUND (X08-3420-10)						
C601			CK73GB1H103K	CHIP C 0.010UF K		
C602			CK73GB1H102K	CHIP C 1000PF K		
C603			CC73GCH1H220J	CHIP C 22PF J		
C604			CC73GCH1H270J	CHIP C 27PF J		
C605,606			CK73GB1H103K	CHIP C 0.010UF K		
C607			CC73GCH1H220J	CHIP C 22PF J		
C608			CK73GB1H102K	CHIP C 1000PF K		
C609,610			CK73GB1H103K	CHIP C 0.010UF K		
C611			CK73GB1H102K	CHIP C 1000PF K		
C612			CK73GB1H103K	CHIP C 0.010UF K		
C613			CD04BJ1H2R2M	ELECTRO 2.2UF 50WV		
C614			CK73GB1H103K	CHIP C 0.010UF K		
C615			CC73GCH1H471J	CHIP C 470PF J		
C616			CD04BJ1E470M	ELECTRO 47UF 25WV		
C617,618			CK73GB1H103K	CHIP C 0.010UF K		
C619			CK73FB1E104K	CHIP C 0.10UF K		
C621			CD04BJ1H2R2M	ELECTRO 2.2UF 50WV		
C622,623			CK73GB1H103K	CHIP C 0.010UF K		
C624			CC73GCH1H101J	CHIP C 100PF J		
C625			CD04BJ1C470M	ELECTRO 47UF 16WV	Y	
C626			CK73GB1H102K	CHIP C 1000PF K		
C627			CD04BJ1C101M	ELECTRO 100UF 16WV		
C631			CK73FB1E104K	CHIP C 0.10UF K		
C632,633			CC73GCH1H221J	CHIP C 220PF J		
C634,635			CC73GCH1H220J	CHIP C 22PF J		
C636,637			CK73GB1H472K	CHIP C 4700PF K		
C654			CD04BJ1H100M	ELECTRO 10UF 50WV		
C656			CD04BJ1E470M	ELECTRO 47UF 25WV		
C657			CD04BJ1A101M	ELECTRO 100UF 10WV		
C659			CD04BJ1A101M	ELECTRO 100UF 10WV		
C660			CC73GCH1H820J	CHIP C 82PF J		
C661			CK73GB1H103K	CHIP C 0.010UF K		
C662			CD04BJ1A101M	ELECTRO 100UF 10WV		
C663			CK73GB1H103K	CHIP C 0.010UF K		
C665			CC73GCH1H330J	CHIP C 33PF J		
C666			CK73FB1E104K	CHIP C 0.10UF K		
C667		*	CD04BJ1C472M	ELECTRO 4700UF 16WV		
C668,669			CK73FB1E104K	CHIP C 0.10UF K		
C670			CD04BJ1H100M	ELECTRO 10UF 50WV		
C671,672			CC73GCH1H220J	CHIP C 22PF J		

L : Scandinavia K : USA P : Canada R : Mexico C : China I : Malaysia
 Y : PX(Far East,Hawaii) T : England E : Europe G : Germany V : China(Shanghai)
 Y : AAFES(Europe) X : Australia Q : Russia H : Korea M : Other Areas △ indicates safety critical components.

Ref. No	Address	New Parts	Parts No.	Description	Destination	Remarks
C673			CD04BJ1H220M	ELECTRO 22UF 50WV		
C675,676			CC73GCH1H220J	CHIP C 22PF J		
C681,682			CC73GCH1H220J	CHIP C 22PF J		
C683			CK73FB1E104K	CHIP C 0.10UF K		
C686,687			CD04BJ1H220M	ELECTRO 22UF 50WV		
C688			CK73FB1E104K	CHIP C 0.10UF K		
C700			CC73GCH1H470J	CHIP C 47PF J		
C701,702			CD04BJ1H100M	ELECTRO 10UF 50WV		
C703,704			CK73GB1H222K	CHIP C 2200PF K		
C705,706			CK73GB1H182K	CHIP C 1800PF K		
C707,708			CC73GCH1H101J	CHIP C 100PF J		
C709			CK73GB1H472K	CHIP C 4700PF K		
C710			CC73GCH1H101J	CHIP C 100PF J		
C711,712			CD04BJ1H100M	ELECTRO 10UF 50WV		
C713,714			CK73GB1H821K	CHIP C 820PF K		
C715,716			CK73GB1H222K	CHIP C 2200PF K		
C717,718			CC73GCH1H101J	CHIP C 100PF J		
C719			CC73GCH1H470J	CHIP C 47PF J		
C720			CC73GCH1H330J	CHIP C 33PF J		
C721,722			CD04BJ1H100M	ELECTRO 10UF 50WV		
C723			CK73GB1H222K	CHIP C 2200PF K		
C724			CK73GB1H822K	CHIP C 8200PF K		
C725			CK73GB1H182K	CHIP C 1800PF K		
C726			CK73GB1H822K	CHIP C 8200PF K		
C727,728			CC73GCH1H101J	CHIP C 100PF J		
C729,730			CD04BJ1H4R7M	ELECTRO 4.7UF 50WV		
C731,732			CC73GCH1H100D	CHIP C 10PF D		
C733,734			CD04BJ1H220M	ELECTRO 22UF 50WV		
C735,736			CC73GCH1H101J	CHIP C 100PF J		
C737,738			CC73GCH1H220J	CHIP C 22PF J		
C739,740			CD04BJ1H100M	ELECTRO 10UF 50WV		
C741			CK73GB1H102K	CHIP C 1000PF K		
C742			CC73GCH1H101J	CHIP C 100PF J		
C744			CC73GCH1H101J	CHIP C 100PF J		
C761,762			CD04BJ1H100M	ELECTRO 10UF 50WV		
C763,764			CK73GB1H182K	CHIP C 1800PF K		
C765,766			CK73GB1H222K	CHIP C 2200PF K		
C767,768			CC73GCH1H101J	CHIP C 100PF J		
C771,772			CK73GB1H821K	CHIP C 820PF K		
C773,774			CD04BJ1H100M	ELECTRO 10UF 50WV		
C775,776			CK73GB1H102K	CHIP C 1000PF K		
C777,778			CC73GCH1H221J	CHIP C 220PF J		
C781,782			CD04BJ1H4R7M	ELECTRO 4.7UF 50WV		
C791,792			CC73GCH1H471J	CHIP C 470PF J		
C901-906			CC73GCH1H470J	CHIP C 47PF J		E4
C901-906			CC73GCH1H470J	CHIP C 47PF J		Y3X4E3
C907,908			CC73GCH1H101J	CHIP C 100PF J		E4
C907,908			CC73GCH1H101J	CHIP C 100PF J		Y3X4E3
C909,910			CK73GB1H103K	CHIP C 0.010UF K		E4
C909,910			CK73GB1H103K	CHIP C 0.010UF K		Y3X4E3
C912,913			CD04BJ1E470M	ELECTRO 47UF 25WV		E4
C912,913			CD04BJ1E470M	ELECTRO 47UF 25WV		Y3X4E3
C915		*	CD04BJ1C471M	ELECTRO 470UF 16WV		E4
C915		*	CD04BJ1C471M	ELECTRO 470UF 16WV		Y3X4E3
C916			CK73FB1E104K	CHIP C 0.10UF K		E4

L : Scandinavia K : USA P : Canada R : Mexico C : China I : Malaysia
 Y : PX(Far East,Hawaii) T : England E : Europe G : Germany V : China(Shanghai)
 Y : AAFES(Europe) X : Australia Q : Russia H : Korea M : Other Areas △ indicates safety critical components.

KRF-V5090D/V6090D/VR-905/906
PARTS LIST

* New Parts
 Parts without **Parts No.** are not supplied.
 Les articles non mentionnés dans le **Parts No.** ne sont pas fournis.
 Teile ohne **Parts No.** werden nicht geliefert.

5

Ref. No	Add-ress	New Parts	Parts No.	Description	Desti-nation	Re-marks
C916			CK73FB1E104K	CHIP C 0.10UF K	Y3X4E3	
C917,918			CC73GCH1H101J	CHIP C 100PF J	E4	
C917,918			CC73GCH1H101J	CHIP C 100PF J	Y3X4E3	
C919,920			CK73GB1H103K	CHIP C 0.010UF K	E4	
C919,920			CK73GB1H103K	CHIP C 0.010UF K	Y3X4E3	
C951,952			CC73GCH1H820J	CHIP C 82PF J		
CN601		*	E41-1234-05	FLAT CABLE CONNECTOR		
CN605		*	E41-1433-05	FLAT CABLE CONNECTOR		
J601		*	E63-1369-05	PIN JACK		
J604		*	E63-1297-05	PIN JACK		
J901		*	E56-0058-05	CYLINDRICAL RECEPTACLE	E4	
J901		*	E56-0058-05	CYLINDRICAL RECEPTACLE	Y3X4E3	
X601			L77-2296-05	CRYSTAL RESONATOR(12.288MHZ)		
CP601,602			RK74GB1J103J	CHIP-COM 10K J 1/16W		
CP603-605		*	RK74GB1J181J	CHIP-COM 180 J 1/16W		
R601,602			RK73GB2A221J	CHIP R 220 J 1/10W		
R603,604			RK73GB2A105J	CHIP R 1.0M J 1/10W		
R605			RK73GB2A103J	CHIP R 10K J 1/10W		
R608			RK73GB2A221J	CHIP R 220 J 1/10W		
R609			RK73GB2A104J	CHIP R 100K J 1/10W		
R610			RK73GB2A221J	CHIP R 220 J 1/10W		
R611,612			RK73GB2A332J	CHIP R 3.3K J 1/10W		
R613,614			RK73GB2A221J	CHIP R 220 J 1/10W		
R615			RK73GB2A101J	CHIP R 100 J 1/10W	Y	
R623			RK73GB2A103J	CHIP R 10K J 1/10W		
R624			RK73GB2A221J	CHIP R 220 J 1/10W		
R625,626			RK73GB2A332J	CHIP R 3.3K J 1/10W		
R627,628			RK73GB2A221J	CHIP R 220 J 1/10W		
R629			RK73GB2A103J	CHIP R 10K J 1/10W		
R630			RK73GB2A333J	CHIP R 33K J 1/10W		
R631			RK73GB2A101J	CHIP R 100 J 1/10W		
R632,633			RK73GB2A472J	CHIP R 4.7K J 1/10W		
R634			RK73GB2A471J	CHIP R 470 J 1/10W		
R635			RK73GB2A750J	CHIP R 75 J 1/10W		
R637,638			RK73GB2A220J	CHIP R 22 J 1/10W		
R639			RK73GB2A183J	CHIP R 18K J 1/10W		
R640			RK73EB2E4R7J	CHIP R 4.7 J 1/4W		
Δ R641			RD14NB2E4R7J	RD 4.7 J 1/4W		
Δ R642			RK73GB2A220J	CHIP R 22 J 1/10W		
Δ R644			RK73GB2A750J	CHIP R 75 J 1/10W		
R645,646			RK73GB2A102J	CHIP R 1.0K J 1/10W		
R647			RK73GB2A103J	CHIP R 10K J 1/10W		
R648			RK73GB2A102J	CHIP R 1.0K J 1/10W		
R651-656			RK73GB2A220J	CHIP R 22 J 1/10W		
R657,658			RK73GB2A221J	CHIP R 220 J 1/10W		
R663			RK73GB2A221J	CHIP R 220 J 1/10W		
Δ R664			RK73EB2E561J	CHIP R 560 J 1/4W		
R665			RK73GB2A223J	CHIP R 22K J 1/10W		
Δ R666			RS14KB3D180J	FL-PROOF RS 18 J 2W		
R667			RK73GB2A221J	CHIP R 220 J 1/10W		
R670			RK73EB2E4R7J	CHIP R 4.7 J 1/4W		
Δ R671			RD14NB2E1R0J	RD 1 J 1/4W		
R672			RK73GB2A221J	CHIP R 220 J 1/10W		

L : Scandinavia K : USA P : Canada R : Mexico C : China I : Malaysia
 Y : PX(Far East,Hawaii) T : England E : Europe G : Germany V : China(Shanghai)
 Y : AAFES(Europe) X : Australia Q : Russia H : Korea M : Other Areas Δ indicates safety critical components .

* New Parts
 Parts without **Parts No.** are not supplied.
 Les articles non mentionnés dans le **Parts No.** ne sont pas fournis.
 Teile ohne **Parts No.** werden nicht geliefert.

5

Ref. No	Add-ress	New Parts	Parts No.	Description	Desti-nation	Re-marks
R673			RK73GB2A473J	CHIP R 47K J 1/10W		
R674			RK73GB2A472J	CHIP R 4.7K J 1/10W		
R675			RK73GB2A221J	CHIP R 220 J 1/10W		
R676			RK73GB2A102J	CHIP R 1.0K J 1/10W		
R677			RK73GB2A152J	CHIP R 1.5K J 1/10W		
R678,679			RK73GB2A220J	CHIP R 22 J 1/10W		
R680			RK73GB2A471J	CHIP R 470 J 1/10W		
Δ R683,684			RK73GB2A471J	CHIP R 470 J 1/10W		
R685			RK73EB2E1R0J	CHIP R 1 J 1/4W		
R689			RK73GB2A220J	CHIP R 22 J 1/10W		
Δ R690			RK73GB2A471J	CHIP R 470 J 1/10W		
Δ R691			RK73EB2E4R7J	CHIP R 4.7 J 1/4W		
R692			RK73GB2A220J	CHIP R 22 J 1/10W		
R693,694			RK73GB2A101J	CHIP R 100 J 1/10W		
R701,702			RK73GB2A222J	CHIP R 2.2K J 1/10W		
R703,704			RK73GB2A104J	CHIP R 100K J 1/10W		
R705,706			RK73GB2A222J	CHIP R 2.2K J 1/10W		
R707,708			RK73GB2A103J	CHIP R 10K J 1/10W		
R709,710			RK73GB2A472J	CHIP R 4.7K J 1/10W		
R711,712			RK73GB2A332J	CHIP R 3.3K J 1/10W		
R713,714			RK73GB2A104J	CHIP R 100K J 1/10W		
R715,716			RK73GB2A222J	CHIP R 2.2K J 1/10W		
R717,718			RK73GB2A222J	CHIP R 2.7K J 1/10W		
R719,720			RK73GB2A562J	CHIP R 5.6K J 1/10W		
R721			RK73GB2A222J	CHIP R 2.2K J 1/10W		
R722			RK73GB2A153J	CHIP R 15K J 1/10W		
R723,724			RK73GB2A104J	CHIP R 100K J 1/10W		
R725			RK73GB2A222J	CHIP R 2.2K J 1/10W		
R726			RK73GB2A183J	CHIP R 18K J 1/10W		
R727,728			RK73GB2A103J	CHIP R 10K J 1/10W		
R729			RK73GB2A472J	CHIP R 4.7K J 1/10W		
R730			RK73GB2A562J	CHIP R 5.6K J 1/10W		
R731,732			RK73GB2A104J	CHIP R 100K J 1/10W		
R733,734			RK73GB2A332J	CHIP R 3.3K J 1/10W		
R735-740			RK73GB2A103J	CHIP R 10K J 1/10W		
R741-744			RK73GB2A221J	CHIP R 220 J 1/10W		
R745			RK73GB2A102J	CHIP R 1.0K J 1/10W		
R746-748			RK73GB2A101J	CHIP R 100 J 1/10W		
R749,750			RK73GB2A272J	CHIP R 2.7K J 1/10W		
R751			RK73GB2A472J	CHIP R 4.7K J 1/10W		
R752			RK73GB2A562J	CHIP R 5.6K J 1/10W		
R753			RK73GB2A472J	CHIP R 4.7K J 1/10W		
R754			RK73GB2A562J	CHIP R 5.6K J 1/10W		
R756-758			RK73GB2A181J	CHIP R 180 J 1/10W		
R759-762			RK73GB2A103J	CHIP R 10K J 1/10W		
R763,764			RK73GB2A104J	CHIP R 100K J 1/10W		
R765,766			RK73GB2A222J	CHIP R 2.2K J 1/10W		
R767,768			RK73GB2A103J	CHIP R 10K J 1/10W		
R769,770			RK73GB2A222J	CHIP R 2.2K J 1/10W		
R771,772			RK73GB2A221J	CHIP R 220 J 1/10W		
R773,774			RK73GB2A104J	CHIP R 100K J 1/10W		
R775,776			RK73GB2A102J	CHIP R 1.0K J 1/10W		
R777-780			RK73GB2A222J	CHIP R 2.2K J 1/10W		
R781,782			RK73GB2A101J	CHIP R 100 J 1/10W		
R791,792			RK73GB2A183J	CHIP R 18K J 1/10W		

L : Scandinavia K : USA P : Canada R : Mexico C : China I : Malaysia
 Y : PX(Far East,Hawaii) T : England E : Europe G : Germany V : China(Shanghai)
 Y : AAFES(Europe) X : Australia Q : Russia H : Korea M : Other Areas Δ indicates safety critical components .

KRF-V5090D/V6090D/VR-905/906 PARTS LIST

* New Parts

Parts without **Parts No.** are not supplied.

Les articles non mentionnés dans le **Parts No.** ne sont pas fournis.

Teile ohne **Parts No.** werden nicht geliefert.

7

Ref. No	Add-ress	New Parts	Parts No.	Description	Desti-nation	Re-marks
R793-804			RK73GB2A220J	CHIP R	22	J 1/10W
R805-808			RK73EB2E1R0J	CHIP R	1	J 1/4W
R809-811			RK73FB2B1R0J	CHIP R	1	J 1/8W
R812-814			RK73EB2E1R0J	CHIP R	1	J 1/4W
R901-904			RK73GB2A750J	CHIP R	75	J 1/10W
R901-904			RK73GB2A750J	CHIP R	75	J 1/10W
R905,906			RK73GB2A104J	CHIP R	100K	J 1/10W
R905,906			RK73GB2A104J	CHIP R	100K	J 1/10W
R907,908			RK73GB2A750J	CHIP R	75	J 1/10W
R907,908			RK73GB2A750J	CHIP R	75	J 1/10W
R911			RK73GB2A472J	CHIP R	4.7K	J 1/10W
R911			RK73GB2A472J	CHIP R	4.7K	J 1/10W
R912			RK73GB2A221J	CHIP R	220	J 1/10W
R912			RK73GB2A221J	CHIP R	220	J 1/10W
R915,916			RD14NB2E100J	RD	10	J 1/4W
R915,916			RD14NB2E100J	RD	10	J 1/4W
R917			RK73GB2A103J	CHIP R	10K	J 1/10W
R917			RK73GB2A103J	CHIP R	10K	J 1/10W
R921			RK73GB2A2R2J	CHIP R	2.2	J 1/10W
R921			RK73GB2A2R2J	CHIP R	2.2	J 1/10W
R922		*	RK73EB2E000J	CHIP R	0	J 1/4W
S601			S62-0034-05	SLIDE SWITCH		Y
D601			1SS355	DIODE		
D602			DAN202U	DIODE		
D602			1SS301	DIODE		
D603			DAP202U	DIODE		
D603			1SS300	DIODE		
D604			HZU3.9(B2)	ZENER DIODE		
D604			UDZS3.9B	ZENER DIODE		
D605			DAN202U	DIODE		
D605			1SS301	DIODE		
D606,607			HZU5.6(B2)	ZENER DIODE		
D606,607			UDZS5.6B	ZENER DIODE		
D608			1SS355	DIODE		
D609		*	D2SBA207009F01	DIODE		
D610			HZU5.1(B2)	ZENER DIODE		
D610			UDZS5.1B	ZENER DIODE		
D611			HZU6.2(B2)	ZENER DIODE		
D611			UDZS6.2B	ZENER DIODE		
D612			HZU5.1(B2)	ZENER DIODE		
D612			UDZS5.1B	ZENER DIODE		
D613,614			1SS355	DIODE		
D900-902			1SR154-400	DIODE		E4
D900-902			1SR154-400	DIODE		Y3X4E3
IC601		*	CS493263-CLZ	MOS-IC		
IC602		*	AK4586VQP	MOS-IC		
IC603			TC7WU04FU-F	MOS-IC		
IC604			TC7WH123FU-F	MOS-IC		
IC605			TC74HCT7007AF	MOS-IC		
IC606			TC74HC07AF	MOS-IC		
IC607			AK4384	MOS-IC		
IC609		*	XC62EP2502MRN	ANALOGUE IC		
IC611		*	BA033LBSG2	ANALOGUE IC		

L : Scandinavia K : USA P : Canada R : Mexico C : China I : Malaysia
 Y : PX(Far East,Hawaii) T : England E : Europe G : Germany V : China(Shanghai)
 Y : AAFES(Europe) X : Australia Q : Russia H : Korea M : Other Areas Δ indicates safety critical components .

* New Parts

Parts without **Parts No.** are not supplied.

Les articles non mentionnés dans le **Parts No.** ne sont pas fournis.

Teile ohne **Parts No.** werden nicht geliefert.

8

Ref. No	Add-ress	New Parts	Parts No.	Description	Desti-nation	Re-marks
Δ IC612			BA05T	ANALOGUE IC		
IC701-704			NJM4565MD-ZB	ANALOGUE IC		
IC705		*	NJU7311AM-ZB	ANALOGUE IC		
IC707,708			NJM4565MD-ZB	ANALOGUE IC		E4
IC901,902		*	MM1228XFBE-E	ANALOGUE IC		
IC901,902		*	MM1228XFBE-E	ANALOGUE IC		Y3X4E3
Q601			DTC124EUA	DIGITAL TRANSISTOR		
Q606			2SB1375	TRANSISTOR		
Q607,608			2SC4081(R,S)	TRANSISTOR		
Q609			2SA1576A(R,S)	TRANSISTOR		
Q701,702			2SC4213(B)	TRANSISTOR		
Q901,902			DTC124EUA	DIGITAL TRANSISTOR		E4
Q901,902			DTC124EUA	DIGITAL TRANSISTOR		Y3X4E3
A601			W02-2802-05	OPTIC RECEIVING MODULE		
AUDIO (X09-6970-10)						
C1_2		*	CD04BJ2A100M	ELECTRO	10UF	100WV
C101			CC45FSL1H331J	CERAMIC	330PF	J
C102			CC45FCH1H101J	CERAMIC	100PF	J
C103,104			CC45FCH1H270J	CERAMIC	27PF	J
C105			CD04BJ1H2R2M	ELECTRO	2.2UF	50WV
C106			CK45FF1H103Z	CERAMIC	0.010UF	Z
C107			CD04BJ1E470M	ELECTRO	47UF	25WV
C108			CK45FB1H561K	CERAMIC	560PF	K
C109			CK45FF1H103Z	CERAMIC	0.010UF	Z
C110			CK45FF1H103Z	CERAMIC	0.010UF	Z
C125			CD04BJ1H100M	ELECTRO	10UF	50WV
C126			CK45FF1H103Z	CERAMIC	0.010UF	Z
C127			CC45FCH1H270J	CERAMIC	27PF	J
C128			CD04BJ1H100M	ELECTRO	10UF	50WV
C129		*	CD04BJ1E332M	ELECTRO	3300UF	25WV
Δ C130			C91-1488-05	MF	6800PF	250VAC
Δ C130			C91-1635-05	FILM	0.068UF	275WV
Δ C130			C91-1648-05	MF	0.068UF	275WV
Δ C131			CK45FF1H103Z	CERAMIC	0.010UF	Z
Δ C132			C91-1635-05	FILM	0.068UF	275WV
Δ C132			C91-1648-05	MF	0.068UF	275WV
C133			CD04BJ1H100M	ELECTRO	10UF	50WV
C134		*	CD04BJ1J330M	ELECTRO	33UF	63WV
C135			CC45FCH1H100D	CERAMIC	10PF	D
C137			CK45FF1H103Z	CERAMIC	0.010UF	Z
Δ C138,139			CD04BJ1E101M	ELECTRO	100UF	25WV
C140		*	CD04BJ1E222M	ELECTRO	2200UF	25WV
C141		*	CD04BJ1E102M	ELECTRO	1000UF	25WV
C141		*	CD04BJ1E102M	ELECTRO	1000UF	25WV
C141		*	CD04BJ1E471M	ELECTRO	470UF	25WV
Δ C141		*	CD04BJ1E471M	ELECTRO	470UF	25WV
Δ C142,143			C90-5775-05	ELECTRO	4700UF	75WV
Δ C142,143		*	C90-5838-05	ELECTRO	4700UF	75WV
C144,145			C90-5777-05	ELECTRO	3300UF	50WV
C144,145		*	C90-5837-05	ELECTRO	3300UF	50WV
C146,147			C91-1422-05	MP	0.10UF	250WV
C148-151			C91-1573-05	MP-C	0.10UF	J
C152,153			C91-1422-05	MP	0.10UF	250WV
C154,155			CQ93FMG1H104J	MYLAR	0.10UF	J

L : Scandinavia K : USA P : Canada R : Mexico C : China I : Malaysia
 Y : PX(Far East,Hawaii) T : England E : Europe G : Germany V : China(Shanghai)
 Y : AAFES(Europe) X : Australia Q : Russia H : Korea M : Other Areas Δ indicates safety critical components .

KRF-V5090D/V6090D/VR-905/906 PARTS LIST

* New Parts
Parts without **Parts No.** are not supplied.
Les articles non mentionnés dans le **Parts No.** ne sont pas fournis.
Teile ohne **Parts No.** werden nicht geliefert.

9

Ref. No	Add-ress	New Parts	Parts No.	Description	Desti-nation	Re-marks
C156			CC45FCH1H330J	CERAMIC 39PF J		
C157			CC45FCH1H270J	CERAMIC 27PF J		
C201,202			CC45FCH1H221J	CERAMIC 220PF J		
C221,222			CC45FCH1H221J	CERAMIC 220PF J		
C225,226			CC45FCH1H221J	CERAMIC 220PF J		
C229,230			CC45FCH1H221J	CERAMIC 220PF J		
C233,234			CC45FCH1H221J	CERAMIC 220PF J		
C237,238			CC45FCH1H221J	CERAMIC 220PF J		
C241,242			CC45FCH1H221J	CERAMIC 220PF J		
C245,246			CC45FCH1H221J	CERAMIC 220PF J	KP	
C251,252			CC45FCH1H221J	CERAMIC 220PF J	EXY	
C255,256			CC45FCH1H221J	CERAMIC 220PF J	EXY	
C259,260			CC45FCH1H221J	CERAMIC 220PF J	EXY	
C265,266			CD04BJ1H4R7M	ELECTRO 4.7UF 50WV		
C268-271			CC45FCH1H101J	CERAMIC 100PF J		
C272			CD04BJ1H2R2M	ELECTRO 2.2UF 50WV		
C273			CK45FB1H471K	CERAMIC 470PF K		
C274			CC45FSL1H331J	CERAMIC 330PF J		
C275			CD04BJ1E470M	ELECTRO 47UF 25WV		
C276			CD04BJ1A101M	ELECTRO 100UF 10WV		
C278			CD04BJ1A101M	ELECTRO 100UF 10WV		
C279			CD04BJ1E470M	ELECTRO 47UF 25WV		
C280			CD04BJ1A101M	ELECTRO 100UF 10WV		
C281			CC45FCH1H101J	CERAMIC 100PF J		
C283-288			CC45FCH1H101J	CERAMIC 100PF J		
C290-299			CC45FCH1H101J	CERAMIC 100PF J	EXY	
C300			CC45FCH1H101J	CERAMIC 100PF J		
C301,302			CD04BJ1H2R2M	ELECTRO 2.2UF 50WV		
C303,304			CK45FB1H471K	CERAMIC 470PF K		
C305,306			CC45FSL1H331J	CERAMIC 330PF J		
C307			CD04BJ1H101M	ELECTRO 100UF 50WV		
C308			CQ93FMG1H473J	MYLAR 0.047UF J		
C309,310			CD04BJ1A101M	ELECTRO 100UF 10WV		
C311			CD04BJ1H4R7M	ELECTRO 4.7UF 50WV		
C312			CQ93FMG1H473J	MYLAR 0.047UF J		
C313			CC45FCH1H101J	CERAMIC 100PF J		
C316,317			CC45FCH1H100D	CERAMIC 10PF D		
C318			CD04BJ1H101M	ELECTRO 100UF 50WV		
C319,320		*	CD04BJ2A101M	ELECTRO 100UF 100WV		
C321,322			CK45FF1H472Z	CERAMIC 4700PF Z		
C323-328			C91-1573-05	MP-C 0.10UF J		
C329			CK45FF1H472Z	CERAMIC 4700PF Z		
C330			CC45FCH1H100D	CERAMIC 10PF D		
C332			CD04BJ1A101M	ELECTRO 100UF 10WV		
C333			CD04BJ1H4R7M	ELECTRO 4.7UF 50WV		
C334			CD04BJ1H010M	ELECTRO 1.0UF 50WV		
C335			CD04BJ1H100M	ELECTRO 10UF 50WV		
C336			CD04BJ1A221M	ELECTRO 220UF 10WV		
C337		*	CD04AJ1E100M	NP ELEC 10UF 25WV		
C338			CD04BJ1E470M	ELECTRO 47UF 25WV		
C339-343			CC45FCH1H101J	CERAMIC 100PF J	EXY	
C344-349			CC45FCH1H101J	CERAMIC 100PF J		
C350			CQ93FMG1H122J	MYLAR 1200PF J		
C351			CQ93FMG1H472J	MYLAR 4700PF J		
C352,353			CD04BJ1H2R2M	ELECTRO 2.2UF 50WV		

L : Scandinavia K : USA P : Canada R : Mexico C : China I : Malaysia
Y : PX(Far East,Hawaii) T : England E : Europe G : Germany V : China(Shanghai)
Y : AAFES(Europe) X : Australia Q : Russia H : Korea M : Other Areas Δ indicates safety critical components.

* New Parts
Parts without **Parts No.** are not supplied.
Les articles non mentionnés dans le **Parts No.** ne sont pas fournis.
Teile ohne **Parts No.** werden nicht geliefert.

10

Ref. No	Add-ress	New Parts	Parts No.	Description	Desti-nation	Re-marks
C354			CK45FB1H471K	CERAMIC 470PF K		
C355,356			CK45FB1H102K	CERAMIC 1000PF K		
C357			CD04BJ1H2R2M	ELECTRO 2.2UF 50WV		
C358			CQ93FMG1H104J	MYLAR 0.10UF J		
C359-364			CD04BJ1H4R7M	ELECTRO 4.7UF 50WV		
C365			CD04BJ1H2R2M	ELECTRO 2.2UF 50WV		
C366,367			CD04BJ1H100M	ELECTRO 10UF 50WV		
C368-370			CD04BJ1H2R2M	ELECTRO 2.2UF 50WV		
C371			CQ93FMG1H104J	MYLAR 0.10UF J		
C372			CQ93FMG1H472J	MYLAR 4700PF J		
C373,374			CQ93FMG1H104J	MYLAR 0.10UF J		
C375			CK45FF1H103Z	CERAMIC 0.010UF Z		
C376,377			CD04BJ1A101M	ELECTRO 100UF 10WV		
C378			CD04BJ1H010M	ELECTRO 1.0UF 50WV		
C379			CK45FB1H471K	CERAMIC 470PF K		
C380			CD04BJ1H4R7M	ELECTRO 4.7UF 50WV		
C384-386			CK45FB1H471K	CERAMIC 470PF K		
C391,392			CC45FCH1H101J	CERAMIC 100PF J		
C401			CD04BJ1A101M	ELECTRO 100UF 10WV		
C403,404		*	CD04BJ2A100M	ELECTRO 10UF 100WV		
C405			CC45FCH1H470J	CERAMIC 47PF J		
C406,407			CD04BJ1H2R2M	ELECTRO 2.2UF 50WV		
C408,409			CK45FB1H471K	CERAMIC 470PF K		
C410,411			CC45FSL1H331J	CERAMIC 330PF J		
C412,413			CD04BJ1A101M	ELECTRO 100UF 10WV		
C416,417			CC45FCH1H100D	CERAMIC 10PF D		
C424,425			CK45FF1H472Z	CERAMIC 4700PF Z		
C426-429			C91-1573-05	MP-C 0.10UF J		
C430			CK45FF1H472Z	CERAMIC 4700PF Z	6	
C431			CC45FCH1H100D	CERAMIC 10PF D	6	
C433			CD04BJ1A101M	ELECTRO 100UF 10WV	6	
C434			CC45FSL1H331J	CERAMIC 330PF J	6	
C435			CK45FB1H471K	CERAMIC 470PF K	6	
C436			CD04BJ1H2R2M	ELECTRO 2.2UF 50WV	6	
C437,438			C91-1573-05	MP-C 0.10UF J	6	
C439-443			CK45FB1H222K	CERAMIC 2200PF K		
C444			CC45FCH1H221J	CERAMIC 220PF J		
C445			CC45FCH1H560J	CERAMIC 56PF J		
C446			CK45FB1H222K	CERAMIC 2200PF K	6	
C638-642			CC45FCH1H470J	CERAMIC 47PF J		
C643-645			CD04BJ1E470M	ELECTRO 47UF 25WV		
C648			CD04AT1C100M	ELECTRO 10UF 16WV		
C652			CD04AT1C100M	ELECTRO 10UF 16WV		
C701			CC45FCH1H101J	CERAMIC 100PF J		
C702			CD04BJ1H2R2M	ELECTRO 2.2UF 50WV	K6P6P5	
C702			CD04BJ1H4R7M	ELECTRO 4.7UF 50WV	Y1Y2X2	
C703			CC45FCH1H101J	CERAMIC 100PF J		
C826,827			CK45FB1H471K	CERAMIC 470PF K		
CN101		*	E41-1429-05	FLAT CABLE CONNECTOR		
CN102		*	E41-1460-05	FLAT CABLE CONNECTOR		
CN103		*	E41-1429-05	FLAT CABLE CONNECTOR		
CN201		*	E41-1234-05	FLAT CABLE CONNECTOR		
J201		*	E63-1372-05	PIN JACK		
J202		*	E63-1370-05	PIN JACK		

L : Scandinavia K : USA P : Canada R : Mexico C : China I : Malaysia
Y : PX(Far East,Hawaii) T : England E : Europe G : Germany V : China(Shanghai)
Y : AAFES(Europe) X : Australia Q : Russia H : Korea M : Other Areas Δ indicates safety critical components.

* New Parts

Parts without **Parts No.** are not supplied.

Les articles non mentionnés dans le **Parts No.** ne sont pas fournis.

Teile ohne **Parts No.** werden nicht geliefert.

11

Ref. No	Add-ress	New Parts	Parts No.	Description	Desti-nation	Re-marks
J203		*	E63-1370-05	PIN JACK	KP	
J203		*	E63-1372-05	PIN JACK	EXY	
J204		*	E63-1373-05	PIN JACK	EXY	
Δ J205			E03-0396-05	AC OUTLET	KPY	
Δ J205			E03-0398-05	AC OUTLET	E	
Δ J206			E03-0325-05	AC OUTLET	X	
J401			E70-0156-05	LOCK TERMINAL BOARD		
J402		*	E70-1004-05	LOCK TERMINAL BOARD	5	
J403			E70-0154-05	LOCK TERMINAL BOARD	6	
J404			E63-1146-05	PIN JACK		
J603		*	E63-1368-05	PIN JACK		
J604		*	E63-1371-05	PIN JACK		
J801			E11-0271-05	PHONE JACK (METAL SLEEVE)		
Δ F101			F05-3121-05	FUSE (SEMKO) (250V T3.15AL)	EXY	
Δ F101			F50-0077-05	FUSE(5X20) (8A)	KP	
Δ F102			F06-1022-05	FUSE (SEMKO) (250V T1AL)	EXY	
Δ F103			F05-3121-05	FUSE (SEMKO) (250V T3.15AL)	Y	
L301-303			L39-1373-05	PHASE COMPENSATION COIL		
L401,402			L39-1373-05	PHASE COMPENSATION COIL		
L403			L39-1373-05	PHASE COMPENSATION COIL	6	
Δ T101			L07-2758-05	POWER TRANSFORMER	KPEX	
Δ T101			L07-2761-05	POWER TRANSFORMER	KPEX	
Δ T101			L07-2805-05	POWER TRANSFORMER	Y	
X101			L77-2002-05	CRYSTAL RESONATOR(4.332MHZ)	EX	
Δ R123			RD14NB2E1R0J	RD 1	J 1/4W	
R124			RS14KB3A221J	FL-PROOF RS 220	J 1W	
R125			RD14NB2E270J	RD 27	J 1/4W	
Δ R126			RD14NB2E101J	RD 100	J 1/4W	
R127			RD14NB2E822J	RD 8.2K	J 1/4W	
Δ R132		*	R92-4677-05	CARBON R 3.3M	K 1/2W	KP
Δ R141,142			RD14NB2E1R0J	RD 1	J 1/4W	
R262			RD14BB2C132J	RD 1.3K	J 1/6W	
Δ R316,317			RS14KB3A472J	FL-PROOF RS 4.7K	J 1W	
R334,335			RD14NB2E4R7J	RD 4.7	J 1/4W	
R338-341			RS14KB3DR22J	FL-PROOF RS 0.22	J 2W	
R342,343			RS14KB3D4R7J	FL-PROOF RS 4.7	J 2W	
R345			RS14KB3D4R7J	FL-PROOF RS 4.7	J 2W	
R347			RD14NB2E4R7J	RD 4.7	J 1/4W	
R348,349			RS14KB3DR22J	FL-PROOF RS 0.22	J 2W	
R365			RD14NB2E561J	RD 560	J 1/4W	
R410			RD14NB2E103J	RD 10K	J 1/4W	
R411			RD14NB2E101J	RD 100	J 1/4W	
R414			RD14NB2E101J	RD 100	J 1/4W	
R415			RD14NB2E103J	RD 10K	J 1/4W	
R436			RD14NB2E4R7J	RD 4.7	J 1/4W	
R438,439			RS14KB3D391J	FL-PROOF RS 390	J 2W	
R452,453			RS14KB3A472J	FL-PROOF RS 4.7K	J 1W	
R460-463			RS14KB3DR22J	FL-PROOF RS 0.22	J 2W	
R466,467			RD14NB2E4R7J	RD 4.7	J 1/4W	
R468,469			RS14KB3D4R7J	FL-PROOF RS 4.7	J 2W	
R473,474			RS14KB3DR22J	FL-PROOF RS 0.22	J 2W	6
R475			RD14NB2E4R7J	RD 4.7	J 1/4W	6
R476			RS14KB3D4R7J	FL-PROOF RS 4.7	J 2W	6
R478-480			RS14KB3A221J	FL-PROOF RS 220	J 1W	

L : Scandinavia K : USA P : Canada R : Mexico C : China I : Malaysia
 Y : PX(Far East,Hawaii) T : England E : Europe G : Germany V : China(Shanghai)
 Y : AAFES(Europe) X : Australia Q : Russia H : Korea M : Other Areas Δ indicates safety critical components .

* New Parts

Parts without **Parts No.** are not supplied.

Les articles non mentionnés dans le **Parts No.** ne sont pas fournis.

Teile ohne **Parts No.** werden nicht geliefert.

12

Ref. No	Add-ress	New Parts	Parts No.	Description	Desti-nation	Re-marks
R995,996			RS14KB3D332J	FL-PROOF RS 3.3K J 2W		
Δ K101			S76-0099-05	MAGNETIC RELAY	KP	
K101			S76-0102-05	MAGNETIC RELAY	EXY	
Δ K401-403			S76-0097-05	MAGNETIC RELAY		
Δ S101			S62.1.5	SLIDE SWITCH	Y	
Δ S102			S68-0107-05	PUSH SWITCH	EXY	
D113			RB441Q-40	DIODE		
Δ D114-116			HSS104A	DIODE		
Δ D114-116			1SS133	DIODE		
Δ D117		*	S1ZB20(7101)	DIODE		
D118			HZS16N(B2)	ZENER DIODE		
D118			MTZJ16(B)	ZENER DIODE		
D119			HZS15N(B2)	ZENER DIODE		
D119			MTZJ15(B)	ZENER DIODE		
Δ D120		*	D2SBA207009F01	DIODE		
Δ D121,122		*	D5SBA20-7003	DIODE		
D123,124			HSS104A	DIODE	Y	
D123,124			1SS133	DIODE	Y	
D201			HZS6.8N(B2)	ZENER DIODE		
D201			MTZJ6.8(B)	ZENER DIODE		
D202			HZS5.1N(B2)	ZENER DIODE		
D202			MTZJ5.1(B)	ZENER DIODE		
D203			HZS6.8N(B2)	ZENER DIODE		
D203			MTZJ6.8(B)	ZENER DIODE		
D215			HSS104A	DIODE		KPY
D215			1SS133	DIODE		KPY
D301,302			HZS15N(B2)	ZENER DIODE		
D301,302			MTZJ15(B)	ZENER DIODE		
D303,304			HSS104A	DIODE		
D303,304			1SS133	DIODE		
D305,306			HZS10N(B2)	ZENER DIODE		EXY
D305,306			HZS11N(B2)	ZENER DIODE		KP
D305,306			MTZJ10(B)	ZENER DIODE		EXY
D305,306			MTZJ11(B)	ZENER DIODE		KP
D307			HZS3.9N(B2)	ZENER DIODE		
D307			MTZJ3.9(B)	ZENER DIODE		
D308-310			HSS104A	DIODE		
D308-310			1SS133	DIODE		
D311,312			HZS3.9N(B2)	ZENER DIODE		
D311,312			MTZJ3.9(B)	ZENER DIODE		
D313			HSS104A	DIODE		
D313			1SS133	DIODE		
D314			HZS3.9N(B2)	ZENER DIODE		
D314			MTZJ3.9(B)	ZENER DIODE		
D315			HSS104A	DIODE		
D315			1SS133	DIODE		
D316			HZS3.9N(B2)	ZENER DIODE		
D316			MTZJ3.9(B)	ZENER DIODE		
D317,318			HSS104A	DIODE		
D317,318			1SS133	DIODE		
D319			HZS11N(B2)	ZENER DIODE		E
D319			MTZJ11(B)	ZENER DIODE		E
D319,320			HZS15N(B2)	ZENER DIODE		KP
D319,320			HZS16N(B2)	ZENER DIODE		XY

L : Scandinavia K : USA P : Canada R : Mexico C : China I : Malaysia
 Y : PX(Far East,Hawaii) T : England E : Europe G : Germany V : China(Shanghai)
 Y : AAFES(Europe) X : Australia Q : Russia H : Korea M : Other Areas Δ indicates safety critical components .

KRF-V5090D/V6090D/VR-905/906
PARTS LIST

* New Parts
Parts without **Parts No.** are not supplied.
Les articles non mentionnés dans le **Parts No.** ne sont pas fournis.
Teile ohne **Parts No.** werden nicht geliefert.

13

Ref. No	Add-ress	New Parts	Parts No.	Description	Desti-nation	Re-marks
D319,320			MTZJ15(B)	ZENER DIODE	KP	
D319,320			MTZJ16(B)	ZENER DIODE	XY	
D320			HZS13N(B2)	ZENER DIODE	E	
D320			MTZJ13(B)	ZENER DIODE	E	
D323			HSS104A	DIODE	E	
D323			1SS133	DIODE		
D401,402			HZS15N(B2)	ZENER DIODE		
D401,402			MTZJ15(B)	ZENER DIODE		
D403,404			HSS104A	DIODE		
D403,404			1SS133	DIODE		
D406-408			HSS104A	DIODE		
D406-408			1SS133	DIODE		
D602,603			HZS5.6N(B2)	ZENER DIODE		
D602,603			MTZJ5.6(B)	ZENER DIODE		
D999			HSS104A	DIODE		
D999			1SS133	DIODE		
Δ IC101		*	BU1924	ANALOGUE IC	EX	
Δ IC105		*	BA05T	ANALOGUE IC		
Δ IC106		*	KIA7812API-UP	ANALOGUE IC		
Δ IC107		*	KIA7912API-UP	ANALOGUE IC		
IC202		*	M61516FP-RF0G	ANALOGUE IC		
IC206		*	NJM4565D-ZB	ANALOGUE IC		
Δ IC301		*	STK413-220A-E	HYBRID IC		
Δ IC401		*	STK412-220A-E	HYBRID IC		
IC607		*	NJM2279D-ZB	ANALOGUE IC		
Δ Q113			2SB1640	TRANSISTOR		
Q114			2SC1740S(Q,R)	TRANSISTOR		
Q114			2SC2785(F,E)	TRANSISTOR		
Δ Q201			2SC1845(F,E)	TRANSISTOR		
Δ Q203			2SA992(F,E)	TRANSISTOR		
Q301-306			2SC2878(B)	TRANSISTOR		
Q307,308			2SA992(F,E)	TRANSISTOR		
Q309-315			2SC1845(F,E)	TRANSISTOR		
Q316			2SA992(F,E)	TRANSISTOR		
Q317,318			2SC2878(B)	TRANSISTOR		
Q319			2SA992(F,E)	TRANSISTOR		
Q401			2SC1845(F,E)	TRANSISTOR		
Q402			2SA1535A	TRANSISTOR		
Q403			2SC3944A	TRANSISTOR		
Q404			2SC1845(F,E)	TRANSISTOR		
Q405			2SA992(F,E)	TRANSISTOR		
Q406			2SB1640	TRANSISTOR		
Q407,408			2SC1845(F,E)	TRANSISTOR		
Q409			2SC1845(F,E)	TRANSISTOR		
Q410,411			DTC113ZSA	DIGITAL TRANSISTOR	6	
Q412			2SC1740S(Q,R)	TRANSISTOR		
Q412			2SC2785(F,E)	TRANSISTOR		
Q701			2SC2878(B)	TRANSISTOR	K6P6P5	
Q701			2SC2878(B)	TRANSISTOR	6	
Q800			2SC1845(F,E)	TRANSISTOR	6	
Q801,802			2SA992(F,E)	TRANSISTOR	6	
Q803			DTC113ZSA	DIGITAL TRANSISTOR	K6P6P5	
Q803			DTC113ZSA	DIGITAL TRANSISTOR	6	

L : Scandinavia K : USA P : Canada R : Mexico C : China I : Malaysia
Y : PX(Far East,Hawaii) T : England E : Europe G : Germany V : China(Shanghai)
Y : AAFES(Europe) X : Australia Q : Russia H : Korea M : Other Areas Δ indicates safety critical components.

* New Parts
Parts without **Parts No.** are not supplied.
Les articles non mentionnés dans le **Parts No.** ne sont pas fournis.
Teile ohne **Parts No.** werden nicht geliefert.

14

Ref. No	Add-ress	New Parts	Parts No.	Description	Desti-nation	Re-marks
DISPLAY (X14-7930-10)						
D805-807			B30-2545-05	LED(RED3(160))		
D808			B30-2597-05	LED(RED HI-BRIGHT)		
C801			CD04AT1H330M	ELECTRO	33UF	50WV
C802,803			CD04AT1H010M	ELECTRO	1UF	50WV
C804			CD04BJ1H470M	ELECTRO	47UF	50WV
C805			CD04AT1A101M	ELECTRO	100UF	10WV
C806		*	CD04AT1E470M	ELECTRO	47UF	25WV
C807			CD04AT1H100M	ELECTRO	10UF	50WV
C809			CD04AT1H010M	ELECTRO	1UF	50WV
C810		*	C90-5839-05	ELECTRIC DOUB	LE LAYER	CAP.
C811			CD04AT1A101M	ELECTRO	100UF	10WV
C812		*	CD04AU1H100M	NP ELEC	10UF	50WV
C813			CK45FF1H103Z	CERAMIC	0.010UF	Z
C814			CC45FCH1H101J	CERAMIC	100PF	J
C815,816			CK45FF1H103Z	CERAMIC	0.010UF	Z
C817			CC45FCH1H101J	CERAMIC	100PF	J
C818,819			CK45FF1H103Z	CERAMIC	0.010UF	Z
C820,821			C91-0769-05	CERAMIC	0.010UF	K
C822-824			CK45FF1H103Z	CERAMIC	0.010UF	Z
C825			CD04AT1H010M	ELECTRO	1UF	50WV
C827			CD04AT1H100M	ELECTRO	10UF	50WV
C828-833			CK45FF1H103Z	CERAMIC	0.010UF	Z
C834			CQ93FMG1H103J	MYLAR	0.010UF	J
C835			CQ93FMG1H104J	MYLAR	0.10UF	J
C836-839			C91-0745-05	CERAMIC	100PF	K
C840			CQ93FMG1H104J	MYLAR	0.10UF	J
C841			C91-0745-05	CERAMIC	100PF	K
C843			CD04BJ1H2R2M	ELECTRO	2.2UF	50WV
C844,845			CK45FF1H103Z	CERAMIC	0.010UF	Z
C846			CQ93FMG1H103J	MYLAR	0.010UF	J
C847,848			C91-0745-05	CERAMIC	100PF	K
C849			CC45FCH1H100D	CERAMIC	10PF	D
C850			CC45FCH1H101J	CERAMIC	100PF	J
C851			C91-0745-05	CERAMIC	100PF	K
C852			CK45FB1H102K	CERAMIC	1000PF	K
CN801		*	E41-1460-05	FLAT CABLE CONNECTOR		
CN802		*	E41-1458-05	FLAT CABLE CONNECTOR		
CN803		*	E41-1462-05	FLAT CABLE CONNECTOR		
X800			L78-0747-05	RESONATOR (4MHZ)		
X801			L78-0725-05	RESONATOR (8.38MHZ)		
CP801			R90-0500-05	MULTI-COMP	100KX6	J 1/4W
CP802			R90-0855-05	MULTI-COMP	100KX5	J
CP803			R90-0493-05	MULTI-COMP	100KX9	J 1/6W
R849			RD14NB2E2R2J	RD	2.2	J 1/4W
S801-812			S70-0031-05	TACT SWITCH		
S801-812			S70-0086-05	TACT SWITCH		
S813,814			T99-0666-05	ROTARY ENCODER		
S815			T99-0664-05	ROTARY ENCODER		
D801			HZS6.2N(B2)	ZENER DIODE		
D801			MTZJ6.2(B)	ZENER DIODE		

L : Scandinavia K : USA P : Canada R : Mexico C : China I : Malaysia
Y : PX(Far East,Hawaii) T : England E : Europe G : Germany V : China(Shanghai)
Y : AAFES(Europe) X : Australia Q : Russia H : Korea M : Other Areas Δ indicates safety critical components.

* New Parts

Parts without **Parts No.** are not supplied.

Les articles non mentionnés dans le **Parts No.** ne sont pas fournis.

Teile ohne **Parts No.** werden nicht geliefert.



Ref. No	Add-ress	New Parts	Parts No.	Description	Desti-nation	Re-marks
D802-804			HSS104A	DIODE	KPY	
D802-804			1SS133	DIODE		
D809			HSS104A	DIODE		
D809			1SS133	DIODE		
D810			HSS104A	DIODE		
D810			1SS133	DIODE	KPY	
D811			HSS104A	DIODE		
D811			1SS133	DIODE	Y	
D812,813			RB441Q-40	DIODE		
D814			HSS104A	DIODE		
D814			1SS133	DIODE		
D816			HSS104A	DIODE	Y	
D816			1SS133	DIODE		
D819-828			HSS104A	DIODE	Y	
D819-828			1SS133	DIODE		
ED801			11-MT-143GNK	FLUORESCENT INDICATOR TUBE	Y	
IC801			MN12510F	MOS-IC		
IC802		*	S-80840CNY-GZ	ANALOGUE IC		
IC803		*	XC6202P502THN	ANALOGUE IC		
IC804		*	MN101C49KDB	MICROCONTROLLER IC		
IC806		*	S-80840CNY-GZ	ANALOGUE IC	Y	
Q802			2SC1740S(Q,R)	TRANSISTOR		
Q802			2SC2785(F,E)	TRANSISTOR		
Q803			2SA1175(F,E)	TRANSISTOR		
Q803			2SA933AS(Q,R)	TRANSISTOR		
Q804-807			2SC1740S(Q,R)	TRANSISTOR	Y	
Q804-807			2SC2785(F,E)	TRANSISTOR		
A801			W02-4599-05	ELECTRIC CIRCUIT MODULE		
VIDEO INPUT (X25-6730-10)						
C101-107			CC45FCH1H100D	CERAMIC	10PF	D
C108,109			CC45FCH1H820J	CERAMIC	82PF	J
C110-115			CD04BJ1H100M	ELECTRO	10UF	50WV
C116			CK45FF1H103Z	CERAMIC	0.010UF	Z
C117			CD04BJ1H100M	ELECTRO	10UF	50WV
C118			CD04BJ1A471M	ELECTRO	470UF	10WV
C119			CK45FF1H103Z	CERAMIC	0.010UF	Z
C120			CD04BJ1H100M	ELECTRO	10UF	50WV
C121			CD04BJ1A471M	ELECTRO	470UF	10WV
C122			CD04BJ1V330M	ELECTRO	33UF	35WV
C123			CD04BJ1H100M	ELECTRO	10UF	50WV
C124			CD04BJ1A471M	ELECTRO	470UF	10WV
C125			CQ93FMG1H104J	MYLAR	0.10UF	J
C126			CD04BJ1E470M	ELECTRO	47UF	25WV
C127-129			CK45FF1H103Z	CERAMIC	0.010UF	Z
C130-132			CQ93FMG1H104J	MYLAR	0.10UF	J
C133			CD04BJ1E470M	ELECTRO	47UF	25WV
C134-141			CK45FF1H103Z	CERAMIC	0.010UF	Z
C511			CD04BJ1H100M	ELECTRO	10UF	50WV
CN501			E41-0928-05	PIN ASSY		
J101		*	E63-1374-05	PIN JACK		
J102		*	E63-1375-05	PIN JACK		
R517			RD14NB2E470J	RD	47	J 1/4W

L : Scandinavia

K : USA

P : Canada

R : Mexico

C : China

I : Malaysia

Y : PX(Far East,Hawaii)

T : England

E : Europe

G : Germany

V : China(Shanghai)

Y : AAFES(Europe)

X : Australia

Q : Russia

H : Korea

M : Other Areas

Δ indicates safety critical components .

* New Parts

Parts without **Parts No.** are not supplied.

Les articles non mentionnés dans le **Parts No.** ne sont pas fournis.

Teile ohne **Parts No.** werden nicht geliefert.



Ref. No	Add-ress	New Parts	Parts No.	Description	Desti-nation	Re-marks
D501			HZS5.6N(B2)	ZENER DIODE	KPY	
D501			MTZJ5.6(B)	ZENER DIODE		
IC101		*	NJM2584D-ZB	ANALOGUE IC		
IC102		*	NJM2580D-ZB	ANALOGUE IC		
Q501			2SC3940A(R,S)	TRANSISTOR		
Q503,504			DTC124ESA	DIGITAL TRANSISTOR		

L : Scandinavia

K : USA

P : Canada

R : Mexico

C : China

I : Malaysia

Y : PX(Far East,Hawaii)

T : England

E : Europe

G : Germany

V : China(Shanghai)

Y : AAFES(Europe)

X : Australia

Q : Russia

H : Korea

M : Other Areas

Δ indicates safety critical components .

HOW TO READ THE PARTS LIST

ABBREVIATION OF MODEL AND MASS PRODUCTION'S DESTINATIONS

MODEL	CNTRY	Australia	Canada	Europe	PX/AAFES	USA
	ABB.	X	P	E	Y	K
KRF-V5090D	5	-	-	E1	Y1	-
KRF-V5090D-S	5	X2	-	E2	Y2	-
KRF-V6090D	6	-	-	E3	Y3	-
KRF-V6090D-S	6	X4	-	E4	-	-
VR-905	5	-	P5	-	-	-
VR-905-S	5	-	P6	-	-	K6
VR-906	6	-	P7	-	-	K7
VR-906-S	6	-	P8	-	-	K8

KRF-V5090D/V6090D/VR-905/906 PARTS LIST

KRF-V5090D/V6090D/VR-905/906

SPECIFICATIONS

For the U.S.A. and Canada

AUDIO section

Rated power output during STEREO operation

100 watts per channel minimum RMS, both channels driven, at 8 Ω from 40 Hz to 20 kHz with no more than 0.7% total harmonic distortion. (FTC)

Effective power output during SURROUND operation

FRONT (40 ~ 20 kHz, 0.7% T.H.D. at 8 Ω one channel driven)	100 W + 100 W
CENTER (40 ~ 20 kHz, 0.7% T.H.D. at 8 Ω one channel driven)	100 W
SURROUND (40 ~ 20 kHz, 0.7% T.H.D. at 8 Ω one channel driven)	100 W + 100 W
SURROUND BACK (40 ~ 20 kHz, 0.7% T.H.D. at 8 Ω one channel driven)(VR-906)	100 W
Total harmonic distortion	0.05% (1 kHz, 50 W, 8 Ω)
Frequency response (IHF'66)	20 Hz ~ 70 kHz, 0 dB, -3.0 dB
Signal to noise ratio (IHF'66)	95 dB
Input sensitivity / impedance	550 mV / 47 kΩ
Output level / impedance	550 mV / 1 kΩ
Tone control	±10 dB (at 100 Hz)
Loudness control	+8 dB (at 100 Hz)

For other countries

AUDIO section

Rated power output during STEREO operation

100 watts per channel minimum RMS, both channels driven, at 8 Ω from 40 Hz to 20 kHz with no more than 0.7% total harmonic distortion. (FTC)

DIN/IEC (63 Hz ~ 12.5 kHz, 0.7% T.H.D., at 8 Ω)	100 W + 100 W
Effective power output during SURROUND operation (1 kHz, 10% T.H.D., at 8 Ω)	120 W + 120 W
Effective power output during SURROUND operation	
FRONT	
(1 kHz, 0.7% T.H.D. at 8 Ω one channel driven)	100 W + 100 W
(1 kHz, 10% T.H.D. at 8 Ω one channel driven)	120 W + 120 W
CENTER	
(1 kHz, 0.7% T.H.D. at 8 Ω one channel driven)	100 W
(1 kHz, 10% T.H.D. at 8 Ω one channel driven)	120 W
SURROUND	
(1 kHz, 0.7% T.H.D. at 8 Ω one channel driven)	100 W + 100 W
(1 kHz, 10% T.H.D. at 8 Ω one channel driven)	120 W + 120 W
SURROUND BACK (KRF-V6090D)	
(1 kHz, 0.7% T.H.D. at 8 Ω one channel driven)	100 W
(1 kHz, 10% T.H.D. at 8 Ω one channel driven)	120 W
Total harmonic distortion	0.05% (1 kHz, 50 W, 8 Ω)
Frequency response (IHF'66)	20 Hz ~ 70 kHz, 0 dB, -3.0 dB
Signal to noise ratio (IHF'66)	95 dB
Input sensitivity / impedance	550 mV / 47 kΩ
Output level / impedance	550 mV / 1 kΩ
Tone control	±10 dB (at 100 Hz)
Loudness control	+8 dB (at 100 Hz)

DIGITAL AUDIO section

Sampling frequency	32 kHz, 44.1 kHz, 48 kHz, 96 kHz
Input level / impedance / wave length	
Optical	(-15 dBm ~ -21 dBm), 660 nm ±30 nm
Coaxial	0.5 Vp-p / 75 Ω

VIDEO section

VIDEO inputs / outputs	
VIDEO (composite)	1 Vp-p / 75 Ω
S-VIDEO inputs / outputs(KRF-V6090D)	
S-VIDEO (luminance signal)	1 Vp-p / 75 Ω
S-VIDEO (chrominance signal)	0.286 Vp-p / 75 Ω
COMPONENT VIDEO inputs / outputs(except for VR-905)	
COMPONENT VIDEO (luminance signal)	1 Vp-p / 75 Ω
COMPONENT VIDEO (CB/CR-signal)	
VR-906	0.64 Vp-p / 75 Ω
KRF-V6090D/KRF-V5090D	0.7 Vp-p / 75 Ω

FM tuner section

Tuning frequency range	87.5 MHz ~ 108.0 MHz
Usable sensitivity (MONO)	
VR-906/VR-905	1.3 μV (75 Ω) / 13.2 dBf (75 kHz DEV., SINAD 30 dB)
KRF-V6090D/KRF-V5090D	1.6 μV (75 Ω) / 15.2 dBf (75 kHz DEV., SINAD 30 dB)
50dB quieting sensitivity	
STEREO	28 μV (75 Ω) / 40.2 dBf
Total harmonic distortion (1 kHz)	
MONO	0.5% (71.2 dBf input)
STEREO	0.7% (71.2 dBf input)
Signal to noise ratio (1 kHz, 75 kHz DEV.)	
MONO	75 dB (71.2 dBf input)
STEREO	68 dB (71.2 dBf input)
Stereo separation (1 kHz)	40 dB
Selectivity (±400 kHz) VR-906/VR-905	70 dB
KRF-V6090D/KRF-V5090D	50 dB
Frequency response (30 Hz ~ 15kHz), +0.5 dB, -3.0 dB	

AM tuner section

Tuning frequency range	
10 kHz step (VR-906/VR-905)	530 kHz ~ 1,700 kHz
10 kHz step (KRF-V6090D/KRF-V5090D)	530 kHz ~ 1,610 kHz
9 kHz step (KRF-V6090D/KRF-V5090D)	531 kHz ~ 1,602 kHz
Usable sensitivity (30% mod., S/N 20dB) (VR-906/VR-905)	16 μV / (600 μV/m)
Usable sensitivity (KRF-V6090D/KRF-V5090D)	16 μV / (600 μV/m)
Signal to noise ratio (30% mod. 1 mV input)	50 dB (60 dBμV EMF input)

GENERAL

Power consumption	
VR-906/VR-905	2.2 A
KRF-V6090D/KRF-V5090D	280 W
Standby Power consumption	
VR-906/VR-905	less than 0.4 W
KRF-V6090D/KRF-V5090D	less than 1.3 W
AC outlet	
SWITCHED	
VR-906/VR-905	(total 150 W 1.25 A max.)
KRF-V6090D/KRF-V5090D	(total 90 W max.)
Dimensions	W: 440 mm (17-5/16")
	H: 143 mm (5-5/8")
	D: 303 mm (11-15/16")
Weight (Net)	
VR-906/VR-905	7.8kg (17.0 lb)
(KRF-V6090D/KRF-V5090D)	8.8kg (19.4 lb)

Notes

- KENWOOD follows a policy of continuous advancements in development. For this reason specifications may be changed without notice.
- The full performance may not be exhibited in an extremely cold location (under a water-freezing temperature).

