

X92-4430-0x

X92-4450-0x

SERVICE MANUAL

DESCRIPTION MECHANISM

X92-4430-00 (DXM-6010W) X92-4450-00 (DXM-6110W)
X92-4430-01 (DXM-6011W) X92-4450-01 (DXM-6111W)
X92-4430-02 (DXM-6012W) X92-4450-02 (DXM-6112W)
X92-4430-03 (DXM-6013W) X92-4450-03 (DXM-6113W)

CONSTRUCTION OF MAJOR PARTS

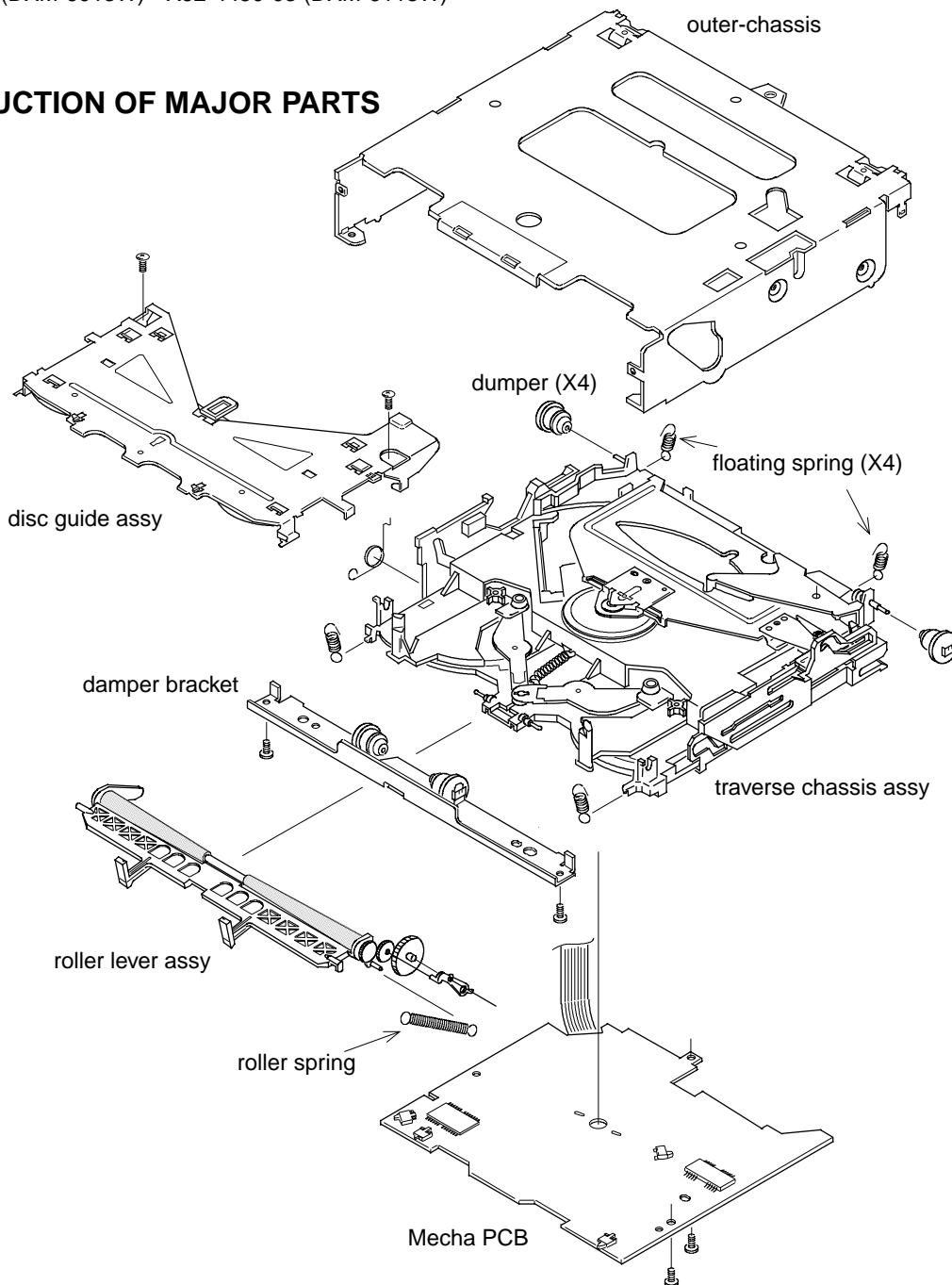

NOTE FOR HANDLING MECHANISM ASSY

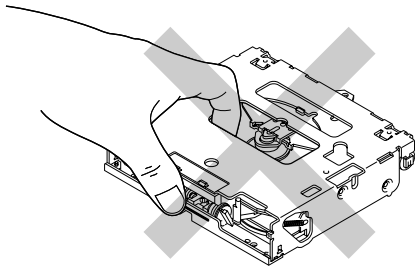

NG Pick is under the finger, it may touch.

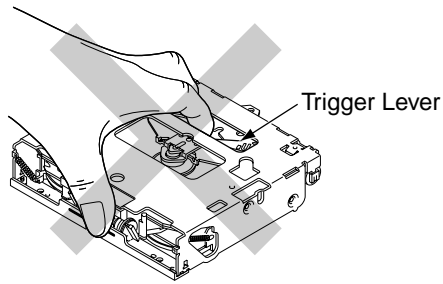

NG Don't touch the lever because the trigger lever comes off.

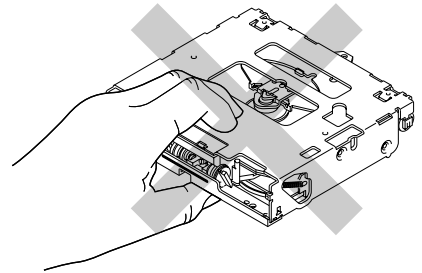

NG Don't have the center of entrance because the disc insertion mouth is transformed.

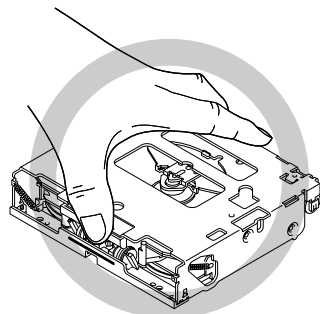

OK

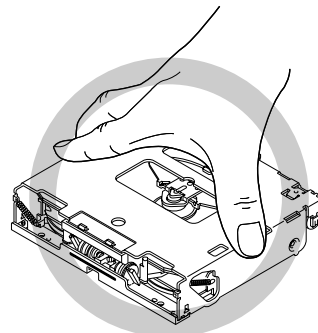

OK

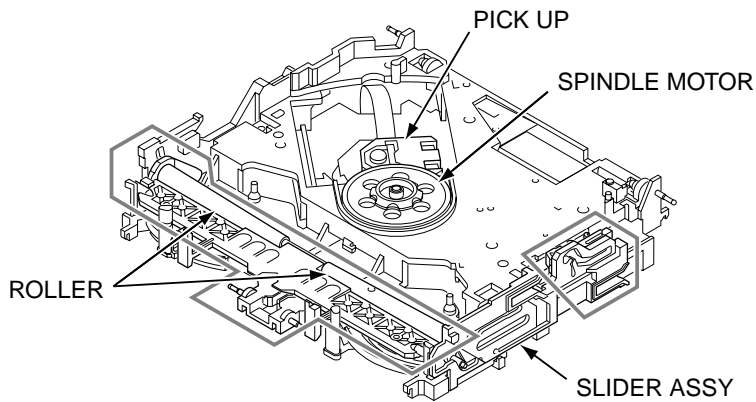

- Don't touch in the frame, since grease is applied to the parts.
- Don't applied grease to the roller.
- Don't touched PICK and SPINDLE MOTOR.

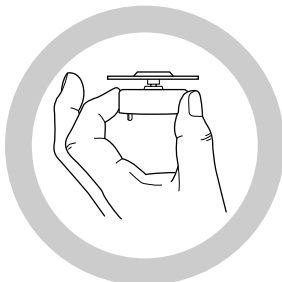

OK

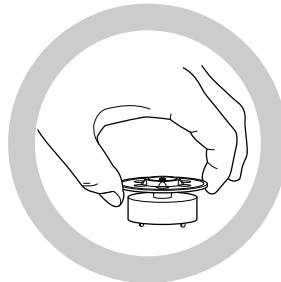

OK

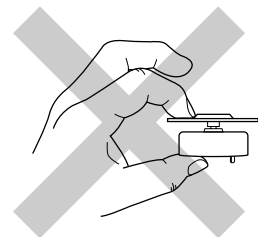

NG

BLOCK DIAGRAM

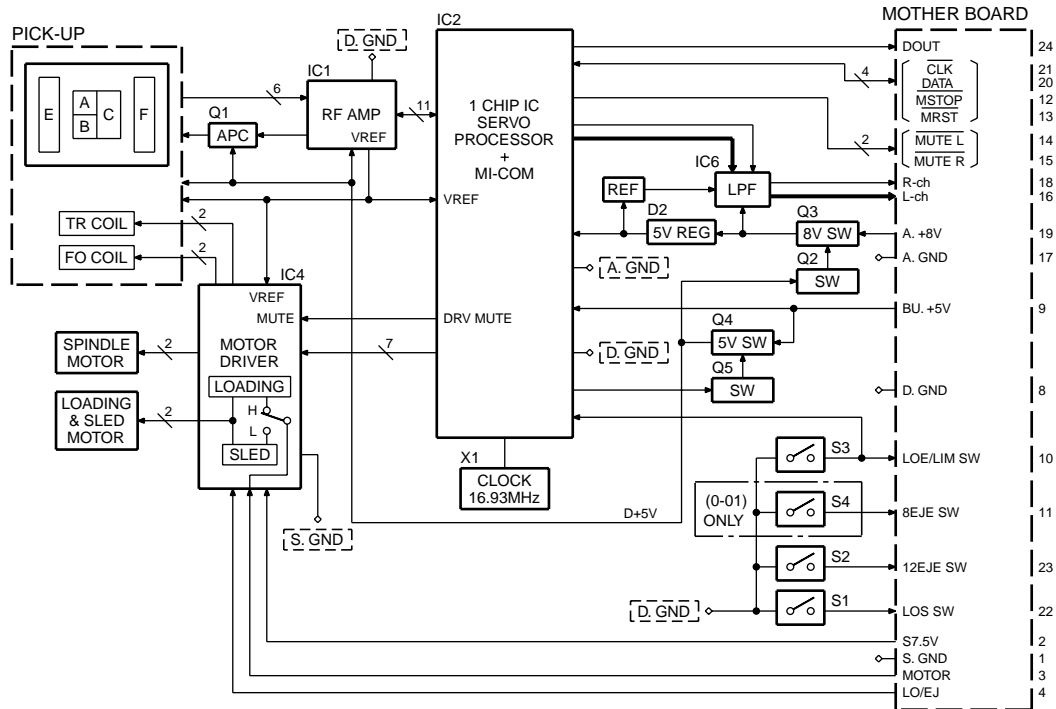

COMPONENTS DESCRIPTION

●CD PLAYER UNIT (X32-5180-0X, X32-5200-0X)

Ref.No.	Component Name	Application/Function	Operation/Condition/Compatibility
IC1	AN22000AA	RF amplifier adapted for CD-RW	Generation of RF signal based on the signals from the APC circuit and pickup, and generation of servo error (focusing error and tracking error) signals. Detection of dropout, anti-shock, track crossing and off-track conditions, included gain control function during CD-RW.
IC2	MN662774KJ2 (X32-5180-0X)	CD signal processor built-in MI-COM.	Focusing, tracking, sled and spindle servo processing. Automatic adjustment (focusing, tracking, gain, offset and balance) operations. Digital signal processing (DSP, PLL, sub-codes, CIRC error correction, audio data interpolation) operations, and Microcomputer function.
IC2	MN662773KH2 (X32-5200-0X)	CD signal processor built-in MI-COM.	Focusing, tracking, sled and spindle servo processing. Automatic adjustment (focusing, tracking, gain, offset and balance) operations. Digital signal processing (DSP, PLL, sub-codes, CIRC error correction, audio data interpolation) operations, included CD-text decoder and Microcomputer function.
IC4	BA5824FP	4CH BTL driver	Focusing coil, tracking coil, spindle motor and sled motor driver, disc loading and eject operation.
IC6	NJM4580M1	Low pass filter	2nd low pass filter for audio signals
Q1	MCH6101	APC	LD power control
Q2	DTC124EUA	A.8V SW	When D.5V SW is turned on, Q2 and Q3 are turned on, and A.+8V is supplied to low pass filter circuit and D/A converter.
Q3	DTA143XUA		
Q4	2SA1362(Y)	D.5V SW	When PON goes Hi, Q4 and Q5 are turned on, and BU+5V is supplied to microprocessor peripheral circuit, IC1 and the pickup.
Q5	DTC124EUA		

MICROCOMPUTER'S TERMINAL DESCRIPTION

●IC2(CD PLAYER UNIT : X32-5180-0X, X32-5200-0X)

Pin No.	Pin Name	I/O	Description	Processing Operation
1	BDO	I	Dropout signal input	Hi : Dropout detected
2	OFT	I	Off-track signal input	Hi : Off-track detected
3	/RFDET	I	RF detection input	Hi : RF signal detected
4	VDET	I	Vibration detection input	Hi : Vibration detected
5	LDON	O	Laser diode ON signal output	Hi : Laser diode ON
6,7	NC	-		Not used (N.C.)
8	AVSS3	-	Ground connection terminal for analogue circuits	Connected to GND lines.
9	AVDD3	-	Positive power supply connection terminal for analogue circuits	Connected to BU 5V lines.
10	FBAL	O	Focusing balance adjustment output	
11	TBAL	O	Tracking balance adjustment output	
12	FE	I	Focusing error signal input	
13,14	NC	-		Not used (N.C.)
15	TE	I	Tracking error signal input	
16-18	NC	-		Not used (N.C.)
19	RFENV	I	RF envelope signal input	
20	VREF	I	VREF input terminal	
21	ARF	I	RF signal input (for DSL)	
22	DRF	I	DSL bias terminal	
23	DSLFB	I/O	DSL loop filter terminal	
24	IREF	I	Reference current input terminal	
25	PLLFB	I/O	PLL loop filter terminal	
26	PLLFB2	I/O	PLL loop filter characteristic switching terminal	
27	VCOFB	I/O	VCO loop filter terminal	
28	VCOFB2	I/O	VCO loop filter terminal	Digital servo 33.8688MHz generation
29	TRV	O	Traverse forced feed output	
30	TVD	O	Traverse drive output	
31	PC	O	Spindle motor ON/OFF output (Lo : ON)	Not used (N.C.)
32	ECM	O	Spindle motor drive output (forced mode output)	
33	ECS	O	Spindle motor drive output	
34	KICK	O	Kick pulse output	
35	TRD	O	Tracking drive output	
36	FOD	O	Focusing drive output	
37	TOFS	O	Tracking off-set adjustment output	
38	AVDD2	-	Positive power supply connection terminal for analogue circuits (for DSL, PLL, AD, DA)	Connected to BU 5V lines.
39	AVSS2	-	Ground connection terminal for analogue circuits (for DSL, PLL, AD, DA)	Connected to GND lines.
40	DVSS2	-	Ground connection terminal for digital circuits	Connected to GND lines.
41	EFM or CK384	O	EFM signal output	Not used (N.C.)
42	PCK or DSLB	O	PLL sampling clock output	
43	/CLDCK	O	Sub-code frame clock signal output	Not used (N.C.)
44	FCLK	O	Crystal frame clock signal output	Not used (N.C.)
45	IPFLAG	O	Interpolation flag signal output (Hi : Interpolated)	Not used (N.C.)
46	FLAG	O	Flag signal output	Not used (N.C.)
47	TRCRS	I	Track crossing signal input	
48	STOUT	O	Serial data output for monitor signal	Not used (N.C.)
49	STLD	O	Load output for monitor signal	Not used (N.C.)
50	SMCK	O	Bit clock signal output for monitor signal	Not used (N.C.)
51	CSEL	I	Crystal oscillation frequency selection terminal	Hi : 33.8688MHz, Lo : 16.9344MHz

MICROCOMPUTER'S TERMINAL DESCRIPTION

Pin No.	Pin Name	I/O	Description	Processing Operation
52	TEST1	I	test terminal 1	Not used (Connected to GND lines)
53	TEST2	I	test terminal 2	Not used (Connected to GND lines)
54	IOSEL	I	Audio DAC data input mode selection terminal	Hi: External data, Lo: Internal data
55	NRST	I	Reset input (Lo: Reset)	Not used(Connected to BU 5V lines)
56	BCLK	O	Bit clock output for SRDATA	Not used (N.C.)
57	LRCK	O	L/R identification signal output	Not used (N.C.)
58	SRDATA	O	Serial data output	Not used (N.C.)
59	SUBC	O	Sub-code serial output	Not used (N.C.)
60	SBCK	I	Clock input for Sub-code serial output	Not used (Connected to GND lines)
61	DQSY	O	CD-TEXT read permission signal output	Not used (N.C.)
62	DEMPH	O	De-emphasis detection signal output (Hi : ON)	Not used (N.C.)
63	TX	O	Digital audio interface signal output	
64	PSEL	I	SRDATA input/Test terminal	Not used (Connected to GND lines)
65	MSEL	I	LRCK input/SMCK output frequency switching	Not used (Connected to GND lines)
66	SSEL	I	BCLK input	Not used (Connected to BU 5V lines)
67	DVDD1	-	Positive power supply connection terminal for digital circuits	Connected to BU 5V lines.
68	X1	I	Crystal oscillation circuit connection terminal	
69	X2	O	Crystal oscillation circuit connection terminal	
70	DVSS	-	Ground connection terminal for digital circuits	Connected to GND lines.
71	XSUB1	I	Microprocessor clock input terminal	Not used (Connected to GND lines)
72	XSUB2	O	Microprocessor clock output terminal	Not used (N.C.)
73	DVDD2	-	Positive power supply connection terminal for digital circuits	Connected to BU 5V lines.
74,75	NC	O		Not used(N.C.)
76	73/74SEL	I	73/74 selection terminal	Hi : CD-TEXT OFF (DXM-601xW) Lo : CD-TEXT ON (DXM-611xW)
77	DRV MUTE	O	Driver muting control terminal	Lo : Spindle motor, focusing actuator and tracking actuator outputs OFF
78,79	NC	O		Not used (N.C.)
80	TEST	I	Test mode switching terminal	Not used (Connected to GND lines)
81	ASEL	I	Audio output polarity detection terminal	Hi : Non inverted, Lo : Inverted
82	PON	O	Audio/digital power supply control terminal	Hi : Power ON
83	SEARCH	O	Servo IC gain switching control terminal	Hi : Search, Lo : Normal operation
84	EQCNT	O	RF amplifier doable-speed switching control terminal	Not used (N.C.)
85	SW3	I	Limit switch detection terminal	Hi→Lo : Pickup most inner position
86	/AMUTE L	O	L Ch. analogue muting control terminal	Lo : Muting requested
87	/AMUTE R	O	R Ch. analogue muting control terminal	Lo : Muting requested
88	CD-RW	O	CD-RW control terminal	Hi : CD-RW, Lo : Normal operation
89	/RST	I	System reset input terminal	Lo : System reset
90	MECHASEL	I	6000/6010 selection terminal	Lo : 6000 series, Hi : 6010 series
91	/MSTOP	I	Standby detection terminal	Hi : Operation mode, Lo : Stop mode
92	LDCNT	O	LD control terminal	Hi : LD ON, Lo : LD OFF
93	DATA	I/O	I2C bus data line (communication line with System microprocessor)	
94	/CLK	I/O	I2C bus clock line (communication line with System microprocessor)	
95	HOT	I	Temperature protection detection terminal	Not used (Connected to GND lines)
96	AVREF	-	A/D converter reference voltage connection terminal	Connected to BU 5V lines.
97	OUT R	O	R Ch. Audio output	
98	AVDD1	-	A/D converter positive power supply connection terminal	Connected to analogue 5V lines.
99	OUT L	O	L Ch. Audio output	
100	AVSS1	-	A/D converter ground connection terminal	Connected to GND lines.

OPERATION DESCRIPTION

[1] Disc Loading

(1) Turning the loading switch ON

- 1) When a disc is inserted, the disc arms open to the left and right and the claw below disc arm (L) sets the loading switch ON.
- 2) The above starts the motor rotation.

Switch ON!

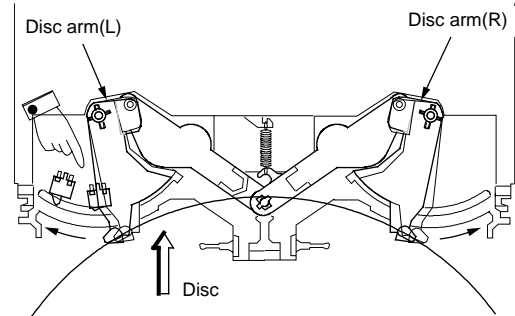

(2) Loading the disc

- 1) When the motor starts rotation, the worm gear also starts to turn as shown in the figure.
- 2) The rotation force is transmitted to the gear train.
- 3) When the force is transmitted to the final gear, the rollers rotate to pull in the disc.

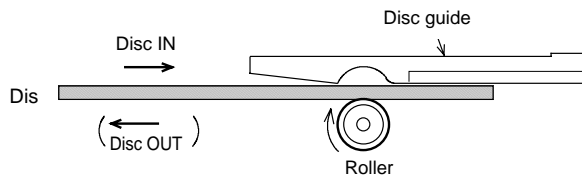

The disc is pulled in or out when the rollers are pushed against the disc guide.

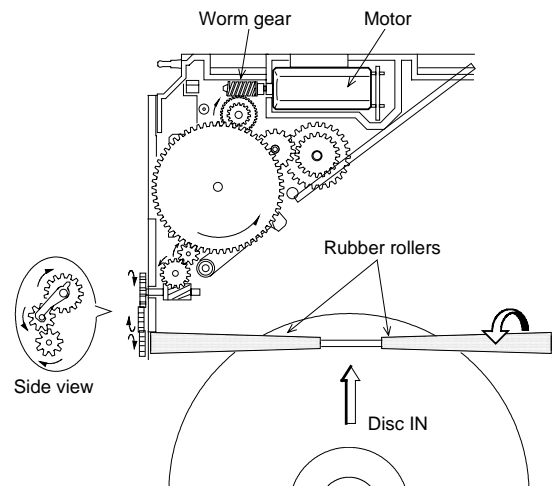

[2] Operation of Slider (R)

(1) Activating the trigger arm

- 1) When the disc is pulled in by the rollers, the disc edge pushes the trigger arm and rotates it.
- 2) When the disc is an 8cm disc, it is pulled upwards by the tapering on the disc guide. The trigger arm is rotated when the disc pushes the claw (section A) located before the trigger arm.

When the 8cm disc reaches the loading end position, the roller areas supporting the disc decreases. To prevent the disc from dropping in this case, the claw is provided with a projection for supporting the disc.

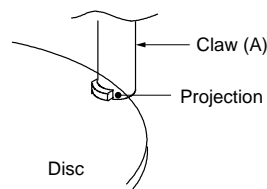
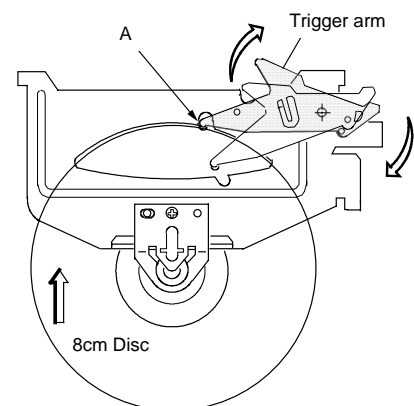
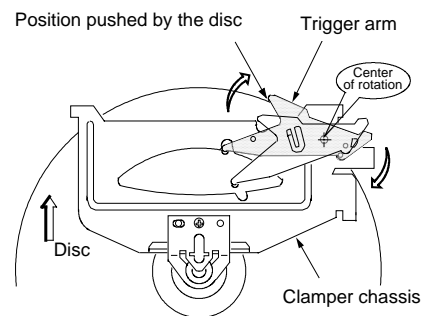

(2) Basic construction (Initial position of the planetary gear mechanism)

- 1) Even after the disc has been inserted, the motor rotated and the gear train also rotated, slider (R) does not start operation yet. This is because the planetary gear mechanism is used and the carrier gear is locked by the slider mechanism. In this period, the planetary gear is in the loose condition.
- 2) When the sun gear is rotating and the carrier gear is locked, the planetary gear is running idle.

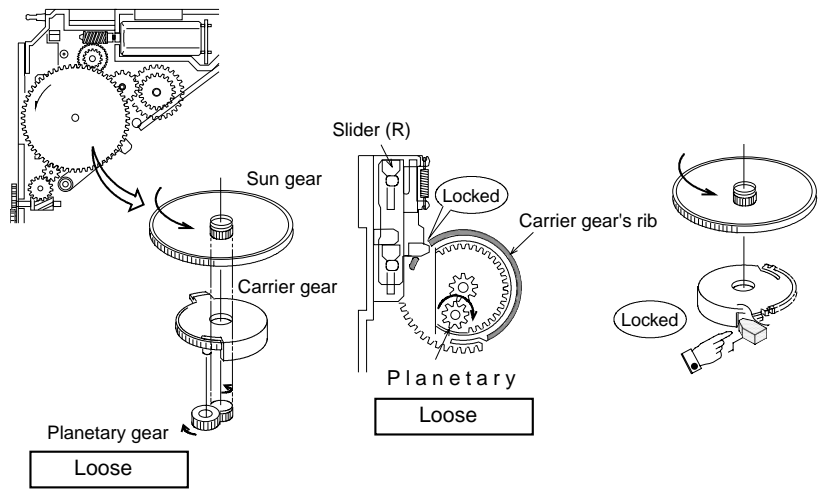

(3) Basic construction (Construction of the trigger slider and slider (R))

The trigger slider is assembled with slider (R) and pushed in the direction of the arrow by the force of a spring.

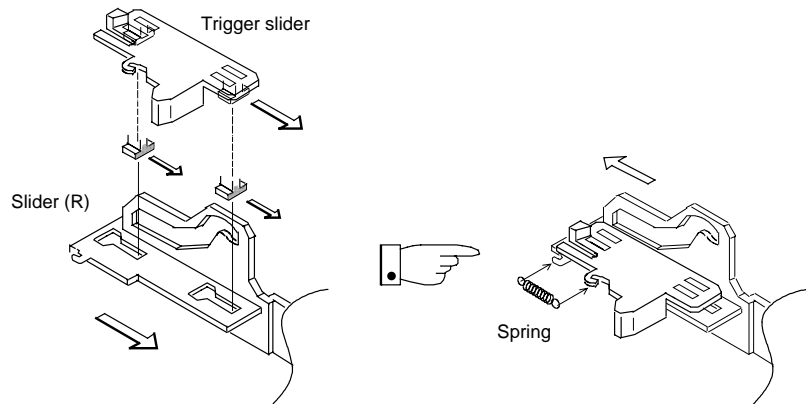

(4) Operation of slider (R)

- 1) Activating the trigger slider
When the trigger arm is rotated by the pressure of the disc, the trigger arm pushes the trigger slider.

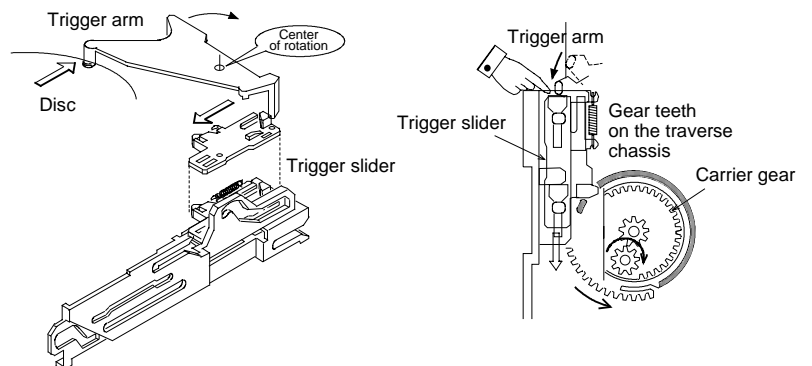

- 2) Rotating (engaging) the planetary gear

When the trigger slider is moved, it pushes down the wall (section A) of the carrier gear. (Initial rotation of the carrier gear)

This causes the planetary gear, which is attached on a pin of the carrier gear, to move according to the rotation of the carrier gear. When the planetary gear is meshed with a gear tooth (section B) of the traverse chassis, the planetary gear starts rotation.

The rotation of the planetary gears causes the carrier gear to rotate.

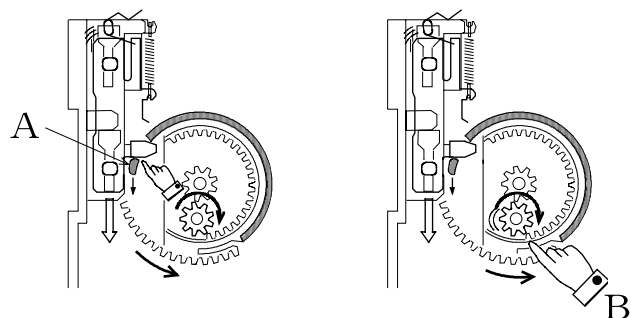

X92-4430-0x

X92-4450-0x

3) Activating slider (R)

When the carrier gear rotates, its wall (section C) pushes and moves the trigger slider.

When the trigger slider is moved, slider (R) is pulled by the force of spring (section D).

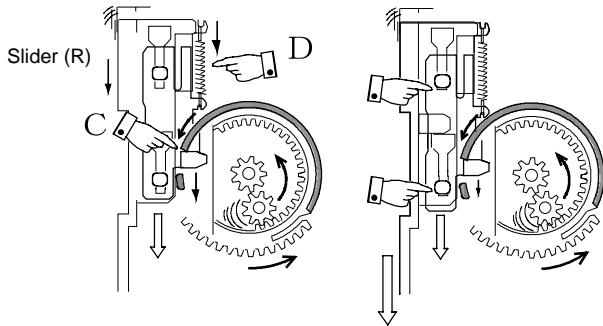

When the trigger slider moves along the longitudinal grooves on slider (R) till the ends of grooves, the trigger slider itself begins to push and move slider (R).

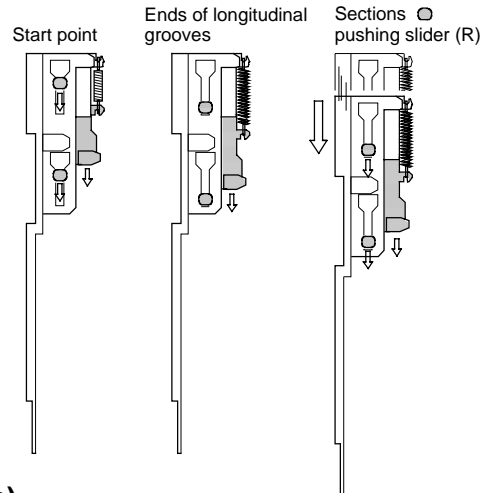

[3] Flow Until Disc Chucking (Playback Standby Condition)

(1) Functions activated by slider (R)

1) Operation modes

To play back a CD, it is required to perform a flow of operations as shown below.

- Pulling the disc in and stopping the roller rotations after it.
- Moving the clamber downwards so that it can clamp the disc during playback. (Disc chucking)
- Moving the rollers that are in contact with the disc. (Lowering the roller lever)

- Float (suspend) the mechanism in order to protect it from vehicle vibrations during disc playback.

- Moving the pickup (optical ass'y) so that it can read the disc signals.

These series of operations are activated by the movement of slider (R).

2) Coupling conditions

The parts used for performing the above functions are coupled with slider (R) as shown below.

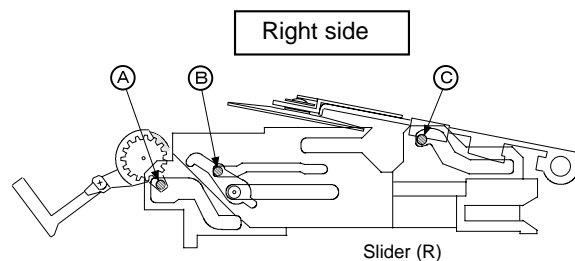
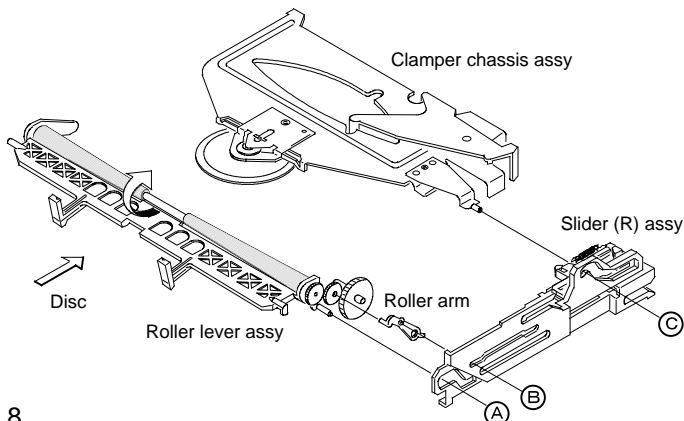

3) Rotation of rollers during disc loading

As shown in the following figure, the motor rotation force is transmitted through sun gear → helical gear 2 → load gear 2 to the gear that is coupled directly with the roller shaft to rotate the rollers and pull in the disc.

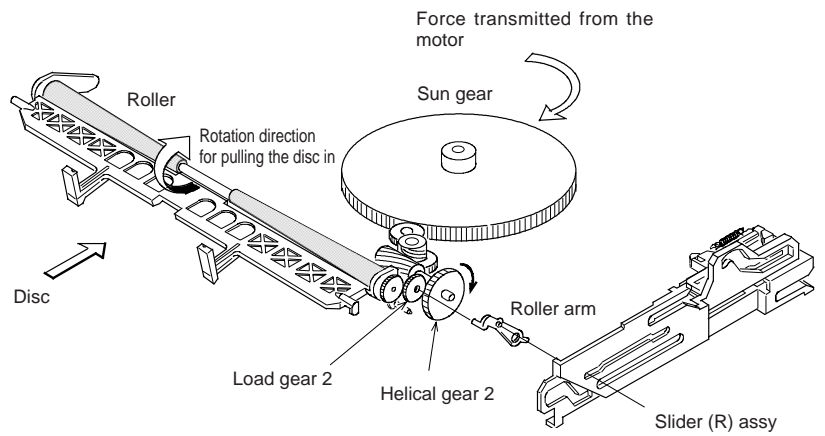

(2) How to stop the roller rotation

The boss of the roller arm is engaged with a groove on slider (R).

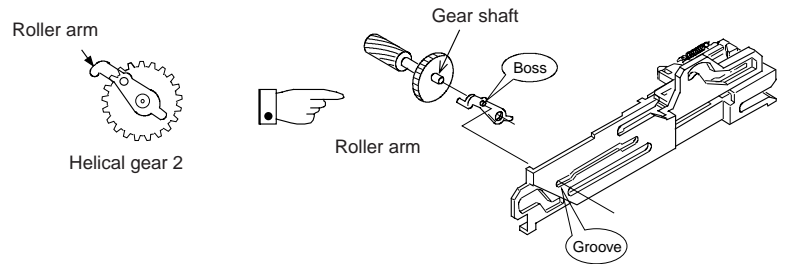

When slider (R) moves, the boss of the roller arm moves along the groove of slider (R), thereby separating the helical gear 2 coupled with it from load gear 2.

This stops transmission of the force to the rollers so the rollers stop.

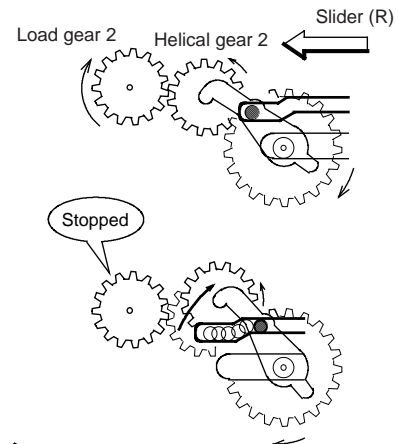
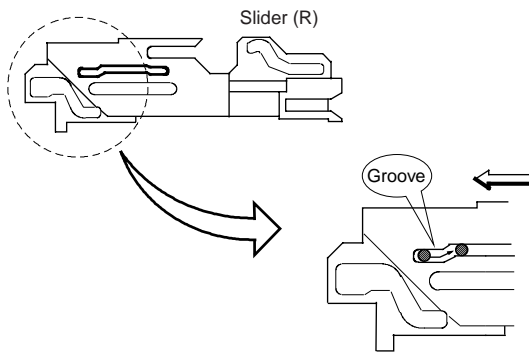

(3) Operation of the clamber (Disc chucking)

1) Engaged condition

The plate spring attached to the clamber chassis is originally engaged with a groove on slider (R).

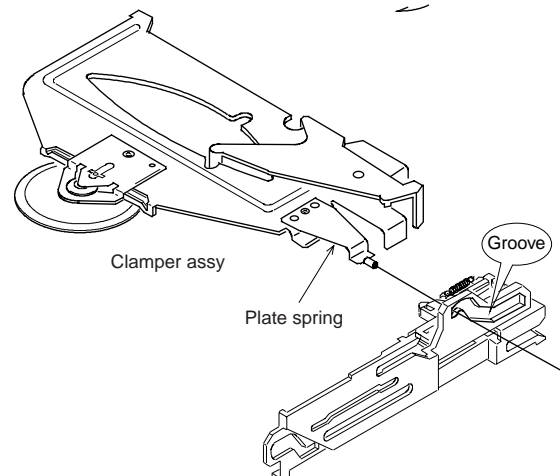

X92-4430-0x X92-4450-0x

- 2) Lowering the clamber (for disc chucking)
As slider (R) moves, the plate spring engaged with it moves along its groove and lowers the clamber chassis assembly.
The following figure shows the flow of operation.

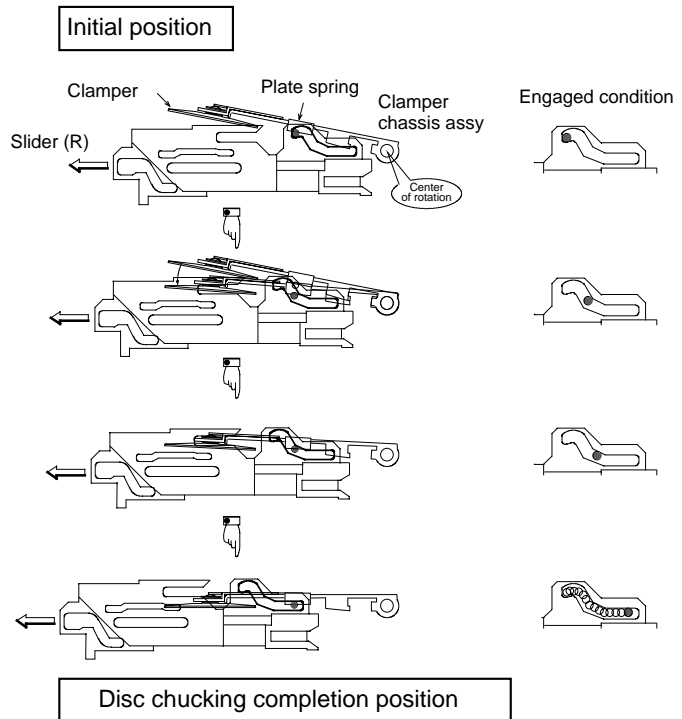

(4) How to lower the rollers

- 1) Disc chucking completion position
When the disc in this position, the rollers are located below the disc and in contact with it.
To rotate the disc for playback, it is required to separate the rollers from the disc.

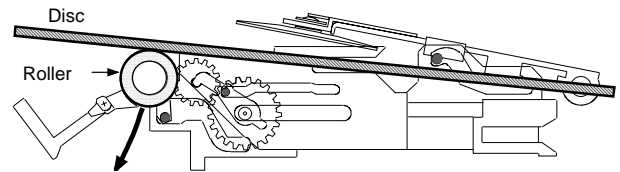

- 2) Lowering the rollers (Disc playback position)
As slider (R) moves, the roller lever shaft engaged with a groove on slider (R) moves along the groove and lowers the rollers.
The following figure shows the flow of operation.

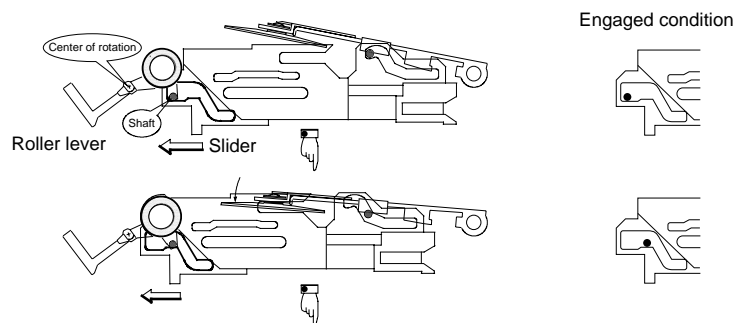

In contrast to the downward movement of the rollers, the extremity of the roller lever starts to be raised.

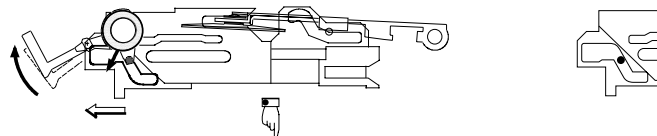

At the lowest position of the rollers

The roller lever extremity comes in the position shown in the figure. Here, it plays a role of stopper for preventing insertion of more than one disc.

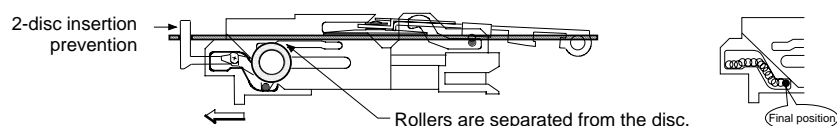

(5) Floating position and lock position of the mechanism

The disc is loaded and ejected by rotation of the rollers that come in close contact with the disc.

After the disc has been pulled in by the rollers, its position should be adjusted so that it can be placed precisely on the turntable of the traverse chassis. To make this possible, the traverse chassis and outer chassis should be in the locked condition.

Since the outer chassis is originally locked on the main unit, if the traverse chassis is also locked during playback, the disc would be subjected directly to vibrations of vehicle during driving and the disc signal would be hindered, making the audio intermittent or impossible to be played.

To prevent such a problem, the traverse chassis is suspended from the outer case using springs or rubber dampers during driving. This positioning protects the disc playback operations and is referred to as the floating position.

Shafts for locking the traverse chassis (Outer case-integrated design)
(4 shafts)

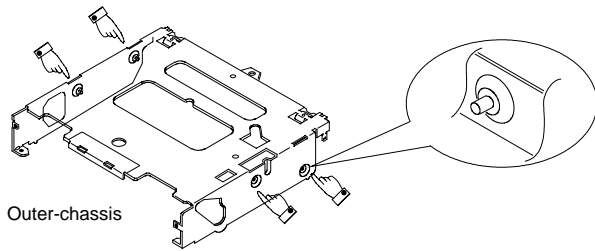

(6) Function of slider (L)

Slider (L) ensures the mechanism lock position because the shafts of the outer chassis are inserted into its grooves in the same way as they are inserted into the grooves on slider (R).

As slider (R) moves, the force moving the roller lever is transmitted to slider (L), which also starts the sliding movement.

When the spring is compressed gradually to a certain point, the force changes to a reverse force, which supports the jump-up operation of the roller lever.

Mechanism lock position

The shafts of the outer chassis are inserted into the grooves on the sliders.

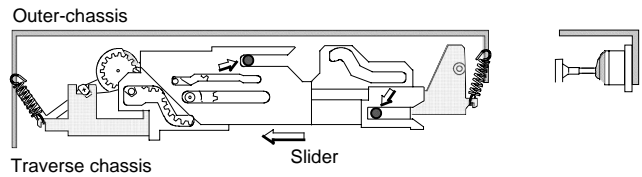

Mechanism floating position

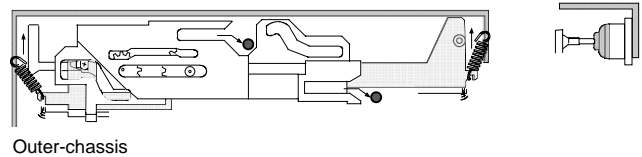

Mechanism lock position

The shafts of the outer chassis are inserted into the grooves on the sliders.

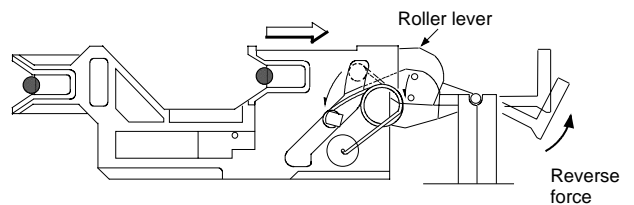
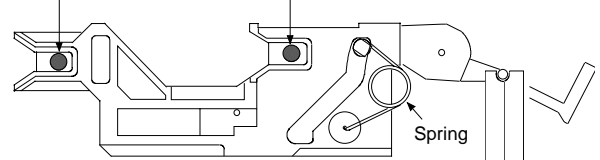

Mechanism floating position

The shafts on the outer chassis are disengaged from the grooves on the slider.

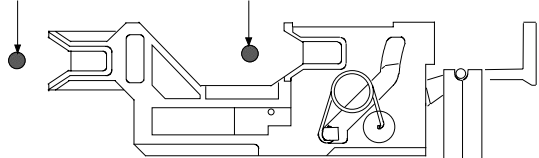

X92-4430-0x

X92-4450-0x

(7) Floating stroke

When the traverse chassis assembly is in the mechanism floating position, stoppers should be provided between the outer case and traverse chassis assembly in order to prevent the mechanism from being damaged by vibrations and shocked of the vehicle.

The distance between the traverse chassis assembly and stoppers, that is, the range in which the traverse chassis assembly can move freely, is referred to as the floating stroke.

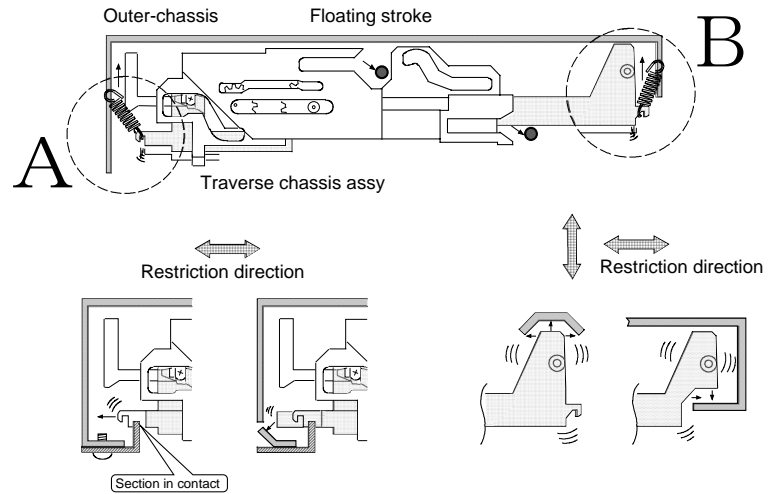

(8) Operation of the pickup

1) Construction

The optical pickup unit is attached on the rack gear.

The following figure shows the positioning of the gears.

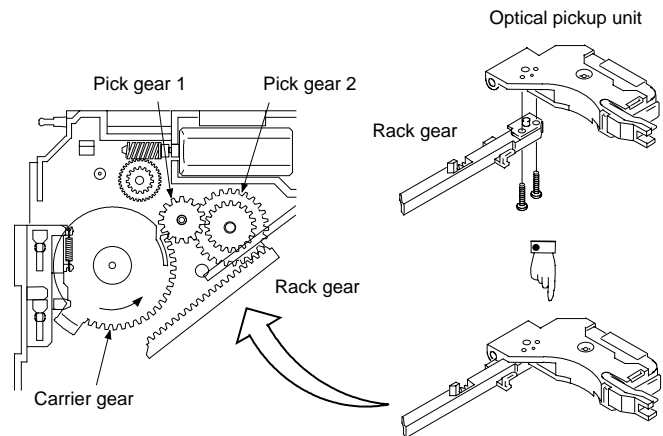

2) Activating the pickup

After the above series of operations have completed and the disc is put in the playback condition, the carrier gear rotates further and is meshed with pick gear 1. The force is then transmitted through pick gear 2 to the rack gear, causing the optical pickup unit to move.

The operation of the optical pickup unit is controlled by the servo circuitry.

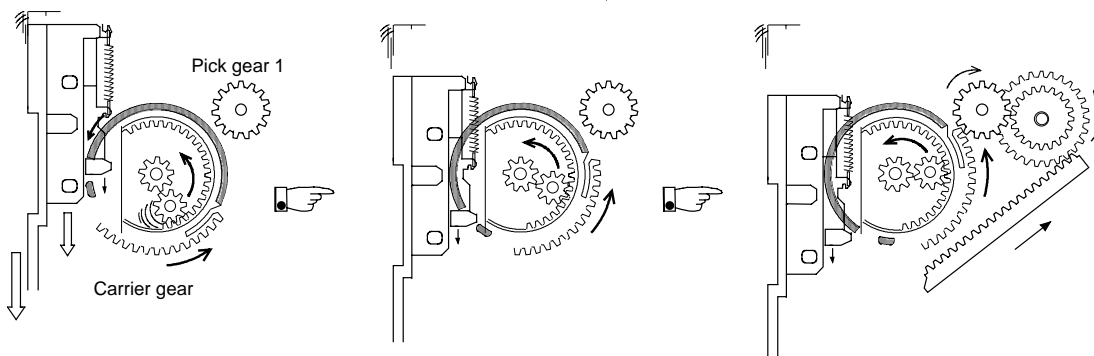
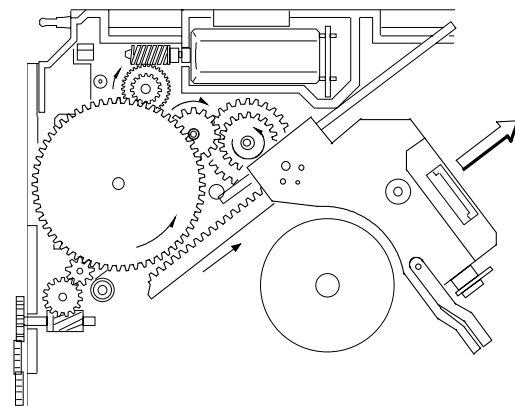

CD PLAYER UNIT (X32-5180-0X/5200-0X)

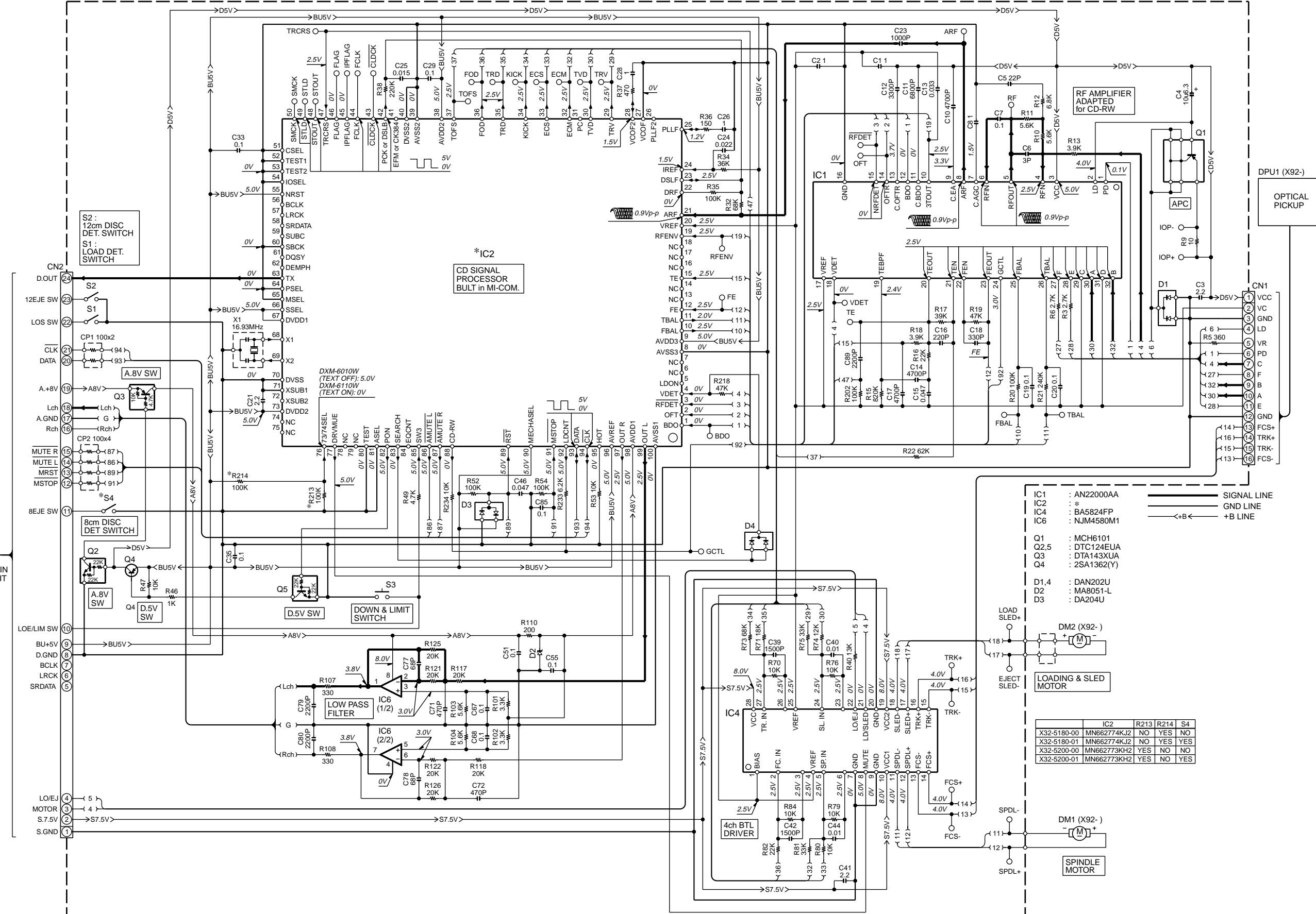

- IC1 : AN2200AA
 IC2 : *
 IC4 : BA5824FP
 IC6 : NJM4580M1
- Q1 : MCH6101
 Q2,5 : DTC124EUA
 Q3 : DTA143XUA
 Q4 : 2SA1362(Y)
- D1,4 : DAN202U
 D2 : MA8051-L
 D3 : DA204U
- | | IC2 | R213 | R214 | S4 |
|-------------|-------------|------|------|-----|
| X32-5180-00 | MN662774KJ2 | NO | YES | NO |
| X32-5180-01 | MN662774KJ2 | NO | YES | YES |
| X32-5200-00 | MN662773KH2 | YES | NO | NO |
| X32-5200-01 | MN662773KH2 | YES | NO | YES |

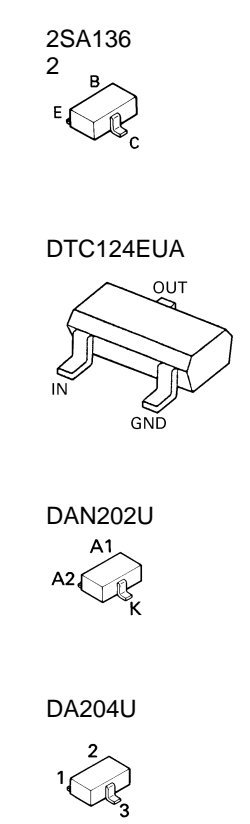

CAUTION: For continued safety, replace safety critical components only with manufacturer's recommended parts (refer to parts list).
 △ Indicates safety critical components. To reduce the risk of electric shock, leakage-current or resistance measurements shall be carried out (exposed parts are acceptably insulated from the supply circuit) when the appliance is returned to the customer.
 • DC voltages are as measured with a high impedance voltmeter. Values may vary slightly due to variations between individual instruments or/and units.

EXPLODED VIEW

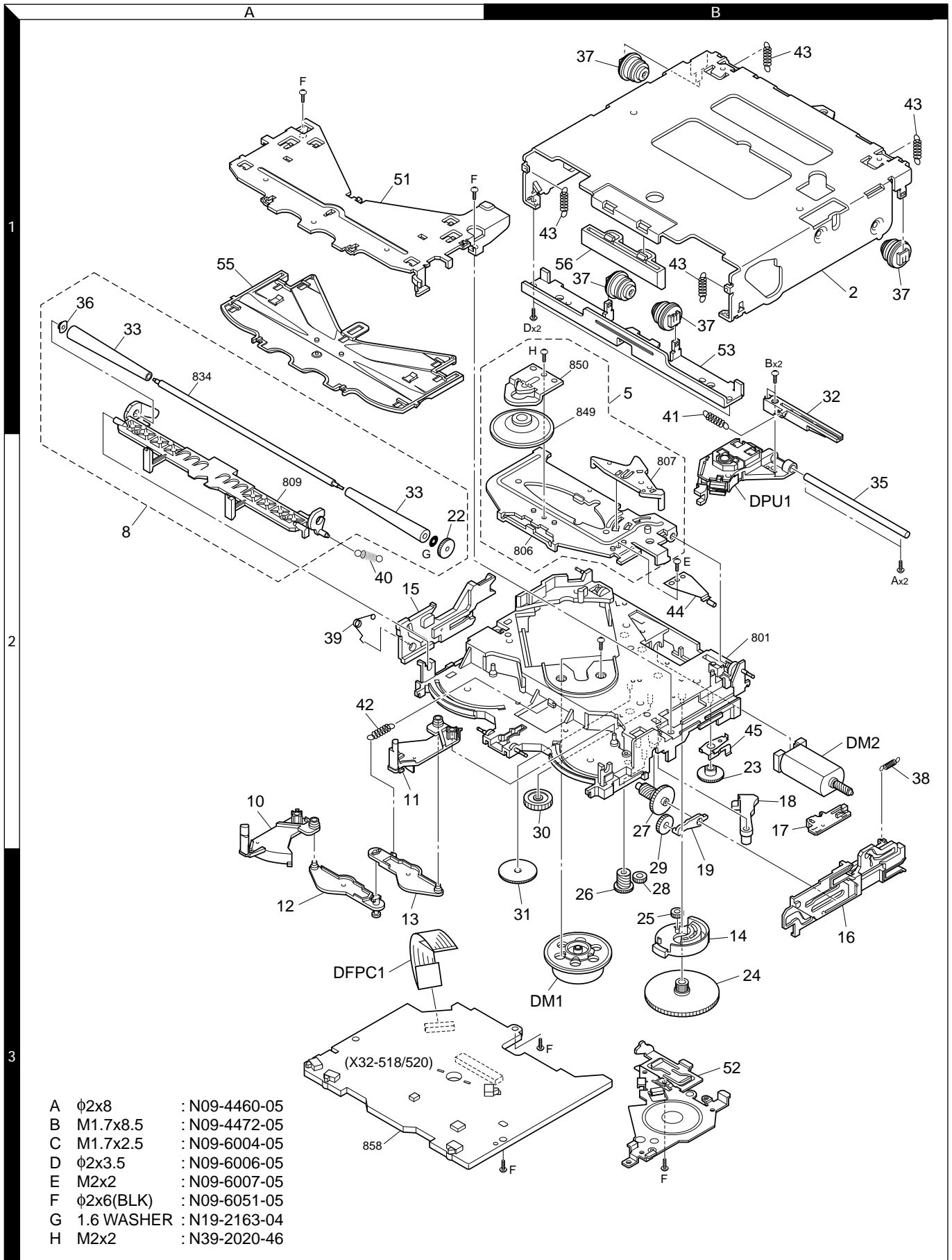

- | | | |
|---|------------|---------------|
| A | φ2x8 | : N09-4460-05 |
| B | M1.7x8.5 | : N09-4472-05 |
| C | M1.7x2.5 | : N09-6004-05 |
| D | φ2x3.5 | : N09-6006-05 |
| E | M2x2 | : N09-6007-05 |
| F | φ2x6(BLK) | : N09-6051-05 |
| G | 1.6 WASHER | : N19-2163-04 |
| H | M2x2 | : N39-2020-46 |

Parts with the exploded numbers larger than 700 are not supplied.

X92-4430-0x X92-4450-0x

PARTS LIST

* New Parts

Parts without **Parts No.** are not supplied.

Les articles non mentionnes dans le **Parts No.** ne sont pas fournis.

Teile ohne **Parts No.** werden nicht geliefert.

Ref. No.	A d d	N e w	Parts No.	Description	Dest in ati on
CD PLAYER UNIT (X32-5180-0X, X32-5200-0X)					
C1 ,2			CK73GB0J105K	CHIP C 1.0UF K	
C3			CK73FB1A225K	CHIP C 2.2UF K	
C4			C92-0566-05	CHIP-TAN 10UF 6.3VV	
C5			CC73GCH1H220J	CHIP C 22PF J	
C6			CC73GCH1H030C	CHIP C 3.0PF C	
C7			CK73GB1C104K	CHIP C 0.10UF K	
C8			CK73GB0J105K	CHIP C 1.0UF K	
C10			CK73GB1H472K	CHIP C 4700PF K	
C11			CK73GB1H682K	CHIP C 6800PF K	
C12			CK73GB1H332K	CHIP C 3300PF K	
C13			CK73GB1C333K	CHIP C 0.033UF K	
C14			CK73GB1H472K	CHIP C 4700PF K	
C15			CK73GB1E473K	CHIP C 0.047UF K	
C16			CC73GCH1H221J	CHIP C 220PF J	
C17			CK73GB1H472K	CHIP C 4700PF K	
C18			CC73GCH1H331J	CHIP C 330PF J	
C19 ,20			CK73GB1C104K	CHIP C 0.10UF K	
C21			CK73FB1A225K	CHIP C 2.2UF K	
C23			CK73GB1H102K	CHIP C 1000PF K	
C24			CK73GB1E223K	CHIP C 0.022UF K	
C25			CK73GB1H153K	CHIP C 0.015UF K	
C26			CK73GB0J105K	CHIP C 1.0UF K	
C28			CK73GB0J105K	CHIP C 1.0UF K	
C29			CK73GB1C104K	CHIP C 0.10UF K	
C33			CK73GB1C104K	CHIP C 0.10UF K	
C35			CK73GB1C104K	CHIP C 0.10UF K	
C39			CK73GB1H152K	CHIP C 1500PF K	
C40			CK73GB1H103K	CHIP C 0.010UF K	
C41			CK73EB1C225K	CHIP C 2.2UF K	
C42			CK73GB1H152K	CHIP C 1500PF K	
C44			CK73GB1H103K	CHIP C 0.010UF K	
C46			CK73GB1E473K	CHIP C 0.047UF K	
C51			CK73GB1C104K	CHIP C 0.10UF K	
C55			CK73GB1C104K	CHIP C 0.10UF K	
C67 ,68			CK73GB1C104K	CHIP C 0.10UF K	
C71 ,72			CK73GB1H471K	CHIP C 470PF K	
C77 ,78			CC73GCH1H680J	CHIP C 68PF J	
C79 ,80			CK73GB1H222K	CHIP C 2200PF K	
C85			CK73GB1C104K	CHIP C 0.10UF K	
C89			CK73GB1H222K	CHIP C 2200PF K	
CN1			E40-9536-05	FLAT CABLE CONNECTOR	
CN1			E41-0193-05	FLAT CABLE CONNECTOR	
CN2			E40-9527-05	FLAT CABLE CONNECTOR	
CN2		*	E41-0213-05	FLAT CABLE CONNECTOR	
X1		*	L78-0851-05	RESONATOR (16.93MHZ)	
CP1			R90-1019-05	MULTI-COMP 100 X2	
CP2			R90-1014-05	MULTI-COMP 100 X4	
R3			RK73GB2A272J	CHIP R 2.7K J 1/10W	
R5			RK73GB2A361J	CHIP R 360 J 1/10W	
R6			RK73GB2A272J	CHIP R 2.7K J 1/10W	
R9			RK73FB2B100J	CHIP R 10 J 1/8W	
R10 ,11			RK73GB2A562J	CHIP R 5.6K J 1/10W	

A : X92-4430-00 (DXM-6010W) A1 : X92-4430-01 (DXM-6011W)
A2 : X92-4430-02 (DXM-6012W) A3 : X92-4430-03 (DXM-6013W)

Ref. No.	A d d	N e w	Parts No.	Description	Dest in ati on
R12			RK73GB2A682J	CHIP R 6.8K J 1/10W	
R13			RK73GB2A392J	CHIP R 3.9K J 1/10W	
R15			RK73GB2A824J	CHIP R 820K J 1/10W	
R16			RK73GB2A223J	CHIP R 22K J 1/10W	
R17			RK73GB2A393J	CHIP R 39K J 1/10W	
R18			RK73GB2A392J	CHIP R 3.9K J 1/10W	
R19			RK73GB2A473J	CHIP R 47K J 1/10W	
R20			RK73GB2A104J	CHIP R 100K J 1/10W	
R21			RK73GB2A244J	CHIP R 240K J 1/10W	
R22		*	RK73GB2A623J	CHIP R 62K J 1/10W	
R32			RK73GB2A683J	CHIP R 68K J 1/10W	
R34			RK73GB2A363J	CHIP R 36K J 1/10W	
R35			RK73GB2A104J	CHIP R 100K J 1/10W	
R36			RK73GB2A151J	CHIP R 150 J 1/10W	
R37			RK73GB2A471J	CHIP R 470 J 1/10W	
R38			RK73GB2A224J	CHIP R 220K J 1/10W	
R40			RK73GB2A133J	CHIP R 13K J 1/10W	
R46			RK73GB2A102J	CHIP R 1.0K J 1/10W	
R47			RK73GB2A103J	CHIP R 10K J 1/10W	
R49			RK73GB2A472J	CHIP R 4.7K J 1/10W	
R52			RK73GB2A104J	CHIP R 100K J 1/10W	
R53			RK73GB2A103J	CHIP R 10K J 1/10W	
R54			RK73GB2A104J	CHIP R 100K J 1/10W	
R70			RK73GB2A103J	CHIP R 10K J 1/10W	
R71			RK73GB2A183J	CHIP R 18K J 1/10W	
R73			RK73GB2A683J	CHIP R 68K J 1/10W	
R74			RK73GB2A123J	CHIP R 12K J 1/10W	
R75			RK73GB2A333J	CHIP R 33K J 1/10W	
R76			RK73GB2A103J	CHIP R 10K J 1/10W	
R79 ,80			RK73GB2A103J	CHIP R 10K J 1/10W	
R81			RK73GB2A333J	CHIP R 33K J 1/10W	
R82			RK73GB2A223J	CHIP R 22K J 1/10W	
R84			RK73GB2A103J	CHIP R 10K J 1/10W	
R101,102			RK73GB2A332J	CHIP R 3.3K J 1/10W	
R103,104			RK73GB2A562J	CHIP R 5.6K J 1/10W	
R107,108			RK73FB2B331J	CHIP R 330 J 1/8W	
R110			RK73FB2B201J	CHIP R 200 J 1/8W	
R117,118			RK73FB2B203J	CHIP R 20K J 1/8W	
R121,122			RK73FB2B203J	CHIP R 20K J 1/8W	
R125,126			RK73FB2B203J	CHIP R 20K J 1/8W	
R202			RK73GB2A104J	CHIP R 100K J 1/10W	
R213			RK73GB2A104J	CHIP R 100K J 1/10W	BB1B2
R213			RK73GB2A104J	CHIP R 100K J 1/10W	B3
R214			RK73GB2A104J	CHIP R 100K J 1/10W	AA1A2
R214			RK73GB2A104J	CHIP R 100K J 1/10W	A3
R218			RK73GB2A473J	CHIP R 47K J 1/10W	
R233			RK73GB2A622J	CHIP R 6.2K J 1/10W	
R234			RK73GB2A103J	CHIP R 10K J 1/10W	
S1 ,2			S68-0863-05	PUSH SWITCH	
S3			S68-0862-05	PUSH SWITCH	
S4			S68-0864-05	PUSH SWITCH	A2A3B2
S4			S68-0864-05	PUSH SWITCH	B3
D1			DAN202U	DIODE	
D2			MA8051-L	ZENER DIODE	

B : X92-4450-00 (DXM-6110W) B1 : X92-4450-01 (DXM-6111W)
B2 : X92-4450-02 (DXM-6112W) B3 : X92-4450-03 (DXM-6113W)

PARTS LIST

* New Parts

Parts without **Parts No.** are not supplied.

Les articles non mentionnes dans le **Parts No.** ne sont pas fournis.

Teile ohne **Parts No.** werden nicht geliefert.

CD PLAYER UNIT (X32-5180-0X, X32-5200-0X)

Ref. No.	A d d	N e w	Parts No.	Description	D e s t i n a t i o n
D3			DA204U	DIODE	
D4			DAN202U	DIODE	
IC1			AN22000AA	ANALOGUE IC	
IC2		*	MN662773KH2	MOS-IC	BB1B2
IC2		*	MN662773KH2	MOS-IC	B3
IC2			MN662774KJ2	MOS-IC	AA1A2
IC2			MN662774KJ2	MOS-IC	A3
IC4			BA5824FP	ANALOGUE IC	
IC6			NJM4580M1	ANALOGUE IC	
Q1			MCH6101	TRANSISTOR	
Q2			DTC124EUA	DIGITAL TRANSISTOR	
Q3			DTA143XUA	DIGITAL TRANSISTOR	
Q4			2SA1362(Y)	TRANSISTOR	
Q5			DTC124EUA	DIGITAL TRANSISTOR	
CD MECHANISM ASSY (X92-4430-0X, X92-4450-0X)					
2	1B		A10-4827-12	CHASSIS (OUTER)	
5	1B		D10-4576-23	ARM ASSY (CLAMPER ASSY)	
8	2A		D10-4579-03	LEVER ASSY (ROLLER ASSY)	
10	3A		D10-4581-13	ARM (DISC L)	
11	2A		D10-4582-13	ARM (DISC L)	
12	3A		D10-4583-03	ARM (JOINT L)	
13	3A		D10-4584-03	ARM (JOINT R)	
14	3B		D10-4585-03	ARM (CARRIER)	
15	2A		D10-4586-03	SLIDER (L)	
16	3B	*	D10-4587-12	SLIDER (R)	
17	3B		D10-4588-03	SLIDER (TRIG)	
18	3B		D10-4595-04	ARM (LOCK)	
19	3B		D10-4596-04	ARM (ROLLER)	
22	2A		D13-2151-04	GEAR (ROLLER)	
23	2B		D13-2152-04	GEAR (HELICAL 1)	
24	3B		D13-2153-04	GEAR (SUN)	
25	3B		D13-2154-04	GEAR (PLANET)	
26	3B		D13-2155-04	WORM (2)	
27	3B		D13-2156-04	GEAR (HELICAL 2)	
28	3B		D13-2157-04	GEAR (LOAD 1)	
29	3B		D13-2158-04	GEAR (LOAD 2)	
30	3B		D13-2168-04	GEAR (PICK 1)	
31	3B		D13-2171-04	GEAR (PICK 2)	
32	2B		D13-2172-03	RACK (GEAR)	
33	2A		D14-0759-04	ROLLER (N100X3DIES)	
35	2B		D21-2382-04	SHAFT (PICK)	
36	1A		D23-0954-04	RETAINER	
37	1B		D39-0246-05	DAMPER	
38	2B		G01-3072-04	EXTENSION SPRING (TRIGGER)	
39	2A		G01-3073-04	TORSION COIL SPRING (ROLLER L)	
40	2A		G01-3074-04	EXTENSION SPRING (ROLLER R)	
41	2B		G01-3075-04	EXTENSION SPRING (PICKUP)	
42	2A		G01-3076-04	EXTENSION SPRING (JOINT SP)	
43	1B		G01-3077-04	EXTENSION SPRING (FLOATING)	
44	2B		G02-1399-04	FLAT SPRING (CLAMP)	
45	2B		G02-1408-04	FLAT SPRING (WORM)	
51	1A		J21-9676-12	MOUNTING HARDWARE (GUIDE BKT)	
52	3B		J21-9677-02	MOUNTING HARDWARE (GEAR BKT)	

Ref. No.	A d d	N e w	Parts No.	Description	D e s t i n a t i o n
53	1B		J21-9678-03	MOUNTING HARDWARE (DAMPER BKT)	
55	1A		J90-1001-11	GUIDE (1)	
56	1B		J90-1023-03	GUIDE (2)	
DFPC1	2B		J84-0128-15	FLEXIBLE P. W. B. (PICKUP FPC)	
A	2B		N09-4460-05	TAPTITE SCREW (OVAL P TAPTIT)	
B	1B		N09-4472-05	MACHINE SCREW (M1.7X8.5)	
C	2B		N09-6004-05	MACHINE SCREW (M1.7X2.5 IB-L)	
D	1B		N09-6006-05	TAPTITE SCREW (PAN ST 2X3.5T)	
E	2B		N09-6007-05	MACHINE SCREW (PAN M2X2)	
F	1A		N09-6051-05	TAPTITE SCREW (BIND P 2X5)	
G	2A		N19-2163-04	FLAT WASHER (1.6X0.25X6)	
H	1B		N39-2020-46	PAN HEAD MACHIN SCREW (M2X2)	
DM1	3B		T42-1066-04	DC MOTOR ASSY (SP)	
DM2	2B		T42-1067-04	DC MOTOR ASSY (LO)	
DPU1	2B		T25-0105-15	OPTICAL PICKUP HEAD	

A : X92-4430-00 (DXM-6010W) A1 : X92-4430-01 (DXM-6011W)
A2 : X92-4430-02 (DXM-6012W) A3 : X92-4430-03 (DXM-6013W)

B : X92-4450-00 (DXM-6110W) B1 : X92-4450-01 (DXM-6111W)
B2 : X92-4450-02 (DXM-6112W) B3 : X92-4450-03 (DXM-6113W)

X92-4430-0x
X92-4450-0x

SPECIFICATIONS

Laser Diode	GaAIAs ($\lambda=780\text{nm}$)
Digital Filter (D/A)	8 Times Over Sampling
D/A Converter	1 Bit
Spindle Speed	500~200rpm (CLV)
Wow & Flutter	Below Measurable Limit
Frequency Response	10Hz-20kHz ($\pm 1\text{dB}$)
Total Harmonic Distortion	0.01% (1kHz)
S/N Ratio	93dB (1kHz)
Dynamic Range	93dB
Channel Separation	85dB

KENWOOD follows a policy of continuous advancements in development. For this reason specifications may be changed without notice.

KENWOOD CORPORATION

14-6, Dogenzaka 1-chome, Shibuya-ku, Tokyo 150-8501 Japan

KENWOOD SERVICE CORPORATION

P.O. BOX 22745, 2201 East Dominguez Street, Long Beach, CA90801-5745, U.S.A.

KENWOOD ELECTRONICS CANADA INC.

6070 Kestrel Road, Mississauga, Ontario, Canada L5T 1S8

KENWOOD ELECTRONICS LATIN AMERICA S.A.

P.O. Box 55-2791 Paitilla, Plaza Credicorp Bank Panama,
Piso 9, Oficina 901, Calle 50, Panama, Rep. de Panama

KENWOOD ELECTRONICS BRASIL LTDA.

Alameda Ministro Rocha Azevedo No. 456,
Edifício Jaú, 10o Andar, Cerqueira César, Cep 0140-001,
São Paulo-SP-Brasil

KENWOOD ELECTRONICS UK LIMITED

Kenwood House, Dwight Road, Watford, Herts, WD1 8EB, United Kingdom

KENWOOD ELECTRONICS DEUTSCHLAND GMBH

Rembrücker-Str. 15, 63150 Heusenstamm, Germany

KENWOOD ELECTRONICS FRANCE S.A.

13, Boulevard Ney, 75018 Paris, France

KENWOOD ELECTRONICS BELGIUM N.V.

Leuvensesteenweg 248 J, 1800 Vilvoorde, Belgium

KENWOOD ELECTRONICS ITALIA S.p.A.

Via G. Sirtori 7/9, 20129 Milano, Italy

KENWOOD IBÉRICA S.A.

Bolivia, 239-08020 Barcelona, Spain

KENWOOD ELECTRONICS AUSTRALIA PTY. LTD. (A.C.N. 001 499 074)

16 Giffnock Avenue, Centrecourt Estate, North Ryde,
N.S.W. 2113, Australia

KENWOOD ELECTRONICS (HONG KONG) LTD.

Unit 3712-3724, Level 37, Tower 1, Metroplaza, 223 Hing Fong Road, Kwai Fong, N.T.,
Hong Kong

KENWOOD ELECTRONICS GULF FZE

P.O. Box 61318, Jebel Ali, Dubai, U.A.E.

KENWOOD ELECTRONICS (THAILAND) CO., LTD.

2019 New Pechburi Road, Bangkok, Huaykwang, Bangkok, 10320 Thailand

KENWOOD ELECTRONICS SINGAPORE PTE. LTD.

1 Genting Lane, #07-00, Kenwood Building, Singapore, 349544

KENWOOD ELECTRONICS (MALAYSIA) SDN BHD

#4.01 Level 4, Wisma Academy Lot 4A, Jalan 19/1, 46300 Petaling Jaya, Selangor Darul Ehsan,
Malaysia