

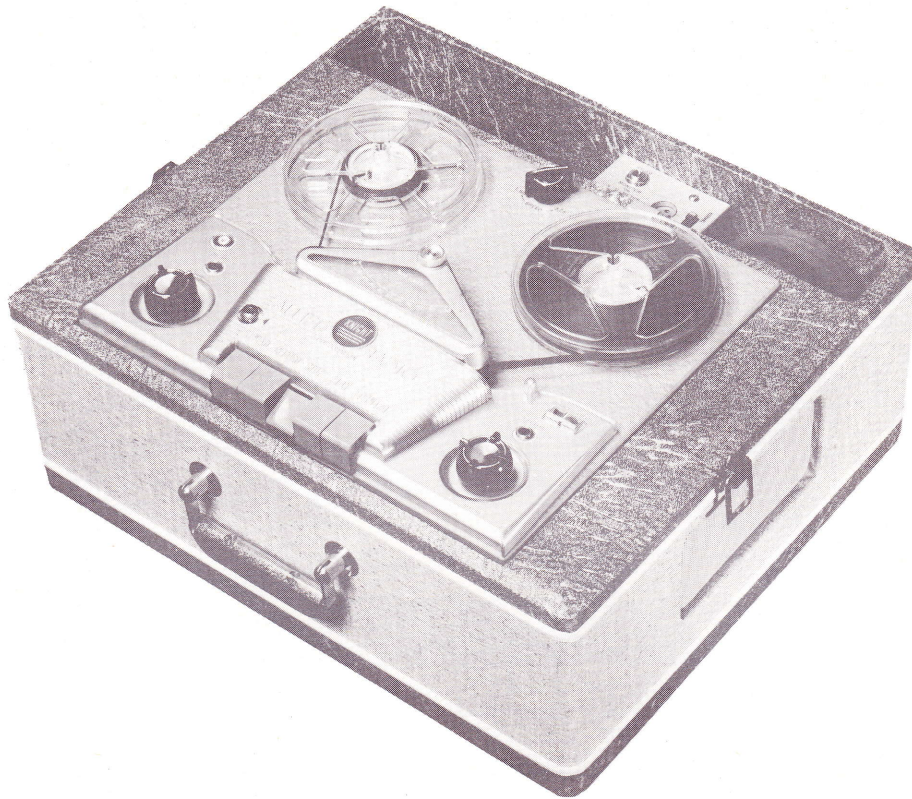

**KNIGHT
MODELS 99RZ177, 99RZ936**



**KNIGHT
MODELS 99RZ177, 99RZ936**

GENERAL INFORMATION

The Knight Models 96RZ936 and 99RZ177 features pushbutton control for playback, record, stop, fast forward and fast reverse. Double track recording is used doubling the recording time on a single reel of tape. Any reel size up to 7" can be used. Two neon indicator lights simplify the recording level setting. Recordings can be made from a radio, phonograph or television in addition to those made directly with the microphone. New recordings may be made on previously recorded tape because the erase head is automatically positioned when pressing the record button. Recordings may be played back through the built in speakers or an external speaker may be plugged into one of the External Speaker Jacks.

Using both tracks of the tape the recording time is as follows:

Size Reel	3 3/4" Speed	7 1/2" Speed
5" reel (600 ft.)	1 hour	1/2 hour
7" reel (1200 ft.)	2 hours	1 hour

The Knight is designed to operate on 115V, 60 cy. AC supply only. Before connecting to a line supply be absolutely certain it agrees with the above specifications.

Supplied By:

**Allied Radio Corporation
833 West Jackson Boulevard
Chicago 7, Illinois**

This material compiled and published by
HOWARD W. SAMS & CO., INC., INDIANAPOLIS, INDIANA

Copyright 1957 • All Rights Reserved

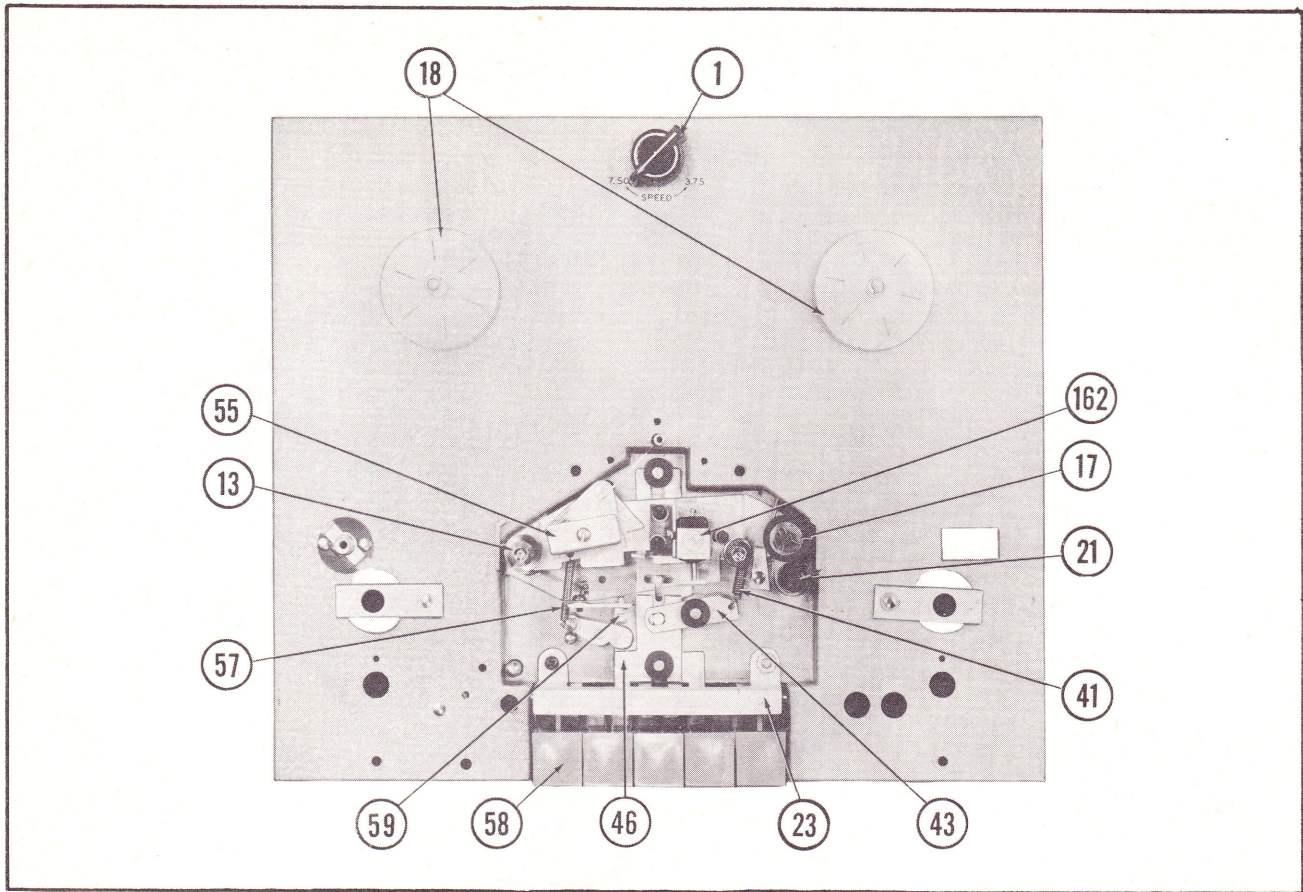

Figure 1

OPERATING INSTRUCTIONS

Preparation For Operation:

1. Remove the AC power cord, microphone, reel of tape and empty reel from the storage compartment.
2. Depress the stop button.
3. Plug the AC cord into a convenient wall receptacle of the proper rating.
4. Set speed control knob to 3.75 or 7.50 as desired.
5. Place "Remote-Normal" switch in "Normal" position.

CAUTION: Do not turn speed change knob unless "Stop" button is depressed.

When the Forward or Reverse buttons are depressed the Record and Playback buttons are locked so they cannot be depressed. This eliminates the possibility of spilling tape. The buttons must be depressed firmly until they latch, and the "Stop" button must be depressed before changing functions or speed of the recorder.

IMPORTANT: Always depress the "Stop" button when the unit is not in use. This prevents the pinch roller from becoming flattened against the capstan.

Speed Change Knob:

This recorder has two speeds 3.75 inches per second or 7.5 inches per second. The arrow on the speed change knob should point at 3.75 or 7.50 according to the speed desired.

CAUTION: Always depress the "Stop" button before attempting to change speed. Turning the speed change knob while the unit is running will not change speed and can result in damage to the mechanism.

Threading The Tape:

1. Place a full reel of tape on the left (supply) spindle, being certain the slots in the reel engage the protrusions on the spindle pan. Unwind about 14" of tape from the supply spindle.
2. Insert free section of tape into the tape slot. Place empty reel on the right (take-up) spindle.
3. Insert free end of tape into one of the slots in the empty reel hub. Hold the tape in place and turn the reel two or three turns until the tape is secured.
4. The dull side of the tape should face away from the operator and toward the rear of the unit.

To Record From Microphone:

1. Turn the On-Off Volume control to the right

until a click is heard and then allow 30 seconds for the unit to warm up. The pilot light located above the "Stop" button will glow when the unit is turned on.

2. Insert the microphone plug into the "Microphone" jack.

3. Push the record lock button down with the left hand and hold. This releases the safety lock which prevents accidental erasure of recorded material.

4. Depress the "Record" button with the right hand until it latches. Release the lock button.

5. Adjust the "Volume" control until the "Normal" indicator just flashes while speaking into the microphone. If the "Volume" control is advanced too far the "Overload" indicator will flash and the recording will be distorted. To prevent overload and distortion turn the volume control down to a point where the "Overload" indicator does not flash.

6. The "Tone" control does not function during recording. When recording from a radio, set the radio tone control for maximum treble.

To Record From Radio, TV, Or Phonograph:

1. Insert the phonograph pick-up plug into the "Radio-P. A. -Phono" jack.

2. For radio or TV recording, connect patch cord, Part No. 96R674, to the voice coil of the radio or TV speaker by means of the alligator clips. Plug into the "Radio-P. A. -Phono" jack.

3. Proceed as described under "To Record From Microphone".

NOTE: Remove patch cord when recording is completed.

To Use Second Track:

1. Depress "Stop" button when all tape is wound on the take-up reel.

2. Remove reel containing tape and empty reel. Place full reel on left (supply) spindle and empty reel on right (takeup) spindle.

3. Thread tape and proceed as previously described.

To Play Recordings:

1. Turn unit on with volume control knob.

2. Thread tape as described under "Threading The Tape".

3. Set the speed change knob (1) to the speed at which the recording was made.

4. Depress the "Play" button until it latches.

5. Adjust "Volume" and "Tone" Controls to desired listening levels.

High Speed Forward Or Reverse:

When it is desirable to play a section of tape over again it is not necessary to play or rewind the

entire tape. By depressing the "Forward" or "Reverse" button the tape will advance or rewind at a rapid speed.

Several minutes of normal recording can be skipped in a few seconds by the "Forward" or "Reverse" buttons.

Tape Timer:

If, when making recordings or playing a recorded tape, you wish to play back a certain recording, note the reading on the time scale when a particular recording is being made or heard. Rewind the tape until that number appears on the scale, press the "Stop" button, then press the "Play" button and you will be listening to the desired recording.

When starting a new reel of tape or re-recording a reel, reset the indicator pointer to "O" by rotating the reset knob (5). By starting at "O" on all tapes, the number location can be catalogued for each selection on any reel.

To Edit And Splice Tape:

NOTE: It is impossible to edit and splice one track without affecting the second track of recorded material, therefore recordings to be edited should be limited to one track only.

1. The tape may be edited by cutting out unwanted sections, or by joining selections into another sequence. Announcements can be added between selections, etc. Unused sections of tape may be spliced together for re-use.

2. For best results cut tape at a slight diagonal, join ends together with splicing tape on the glossy side and trim off any excessive width.

Erasing Recorded Material:

When the "Record" button is depressed the erase head is automatically positioned to erase any previous recording before a new one is made. Material may be erased when no longer needed, without recording, by turning the volume control to the extreme counter-clockwise position, or minimum volume position, and depress the "Record" button. To erase the second track, reverse the reels and repeat the above operation.

To Use Recorder As A Public Address System:

Insert the Microphone into the "Microphone" input jack. Plug in an extension speaker, or speakers if desired, and depress the "Record" button. Set the "Volume" and "Tone" controls to the desired listening level. A recording can be made at the same time with a tape placed on the unit in the normal manner.

CAUTION: When using the unit as a public address system, the Microphone must be kept as far away from the speakers as possible to prevent "feedback" squeal.

Remote Control Operation:

A socket and switch are provided to allow remote operation up to a distance of 18 feet on either recording or playback. This is accomplished by remote control cable No. 96R636. Connect remote control cable as follows:

1. Set remote control cable switch at end of cable to "Standby" position.
2. Insert cable plug into remote socket.
3. Set the control switch on the remote socket to the "Normal" position. Start the recorder in the usual manner and set the "Volume" control to the proper level.
4. Set the control switch on the set to the "Remote" position. The tape will stop.

The recorder may now be operated (start and stop) by means of the remote cable switch. When starting the recorder by means of the remote control, the switch should be rotated to the "Motor" position and then to the "Record-Playback" position after a slight pause in the "Motor" position. To stop recording or playback, rotate the control switch directly to the "Standby" position, with just a slight pause at the "Motor" position.

ADJUSTMENTS

Record-Play Head Adjustment: (See Exploded View, Fig. 3A)

To adjust the record-play head (162) for maximum frequency response, adjust as follows:

1. Remove the rear escutcheon (6) and rear escutcheon plate (7).
2. Thread an alignment tape or a good recorded tape on the machine.
3. Set the controls as described under "To Play Recordings".
4. Adjust screw (33) by turning it in and out until the maximum high frequencies are obtained. Replace escutcheon and plate.

Pressure Pad Adjustment:

1. Remove front escutcheon (11).
2. Depress the "Play" button. Do not turn the recorder on.
3. Using a pencil type postal scale, check the amount of pressure required to just pull the pad away from the tape. The test should be made on the end of the pressure pad mounting spring (60). Adjust the pressure pad for $1 \frac{3}{4}$ oz. \pm $\frac{1}{4}$ oz. pressure.
 - (a) The record head pressure pad is adjusted by locked adjusting screw (59).
 - (b) The guide post pressure pad is adjusted by bending the pressure pad spring. It must be adjusted for minimum pressure against the tape.
4. After the adjustments depress the "Stop" button and replace the front escutcheon.

Erase Head Adjustment:

1. With tape properly threaded, turn on recorder and depress the "Record" button. Allow tape to run for a few seconds and turn recorder off, leaving the "Record" button depressed.

2. With the escutcheons removed check the erase head (55) to see if it is parallel with the tape.

3. Check to see if the top edge of the tape coincides with the top end of the long diagonal slot in the erase head (Junction of long diagonal slot and short vertical slot). To adjust level of tape, loosen set screw (12) in left tape guide post, and rotate guide post to move tape up or down. Tighten set screw.

Brake Shoe Adjustment:

1. In order to adjust the brake shoes it is necessary to remove the mechanism from the carrying case and disconnect the speaker.
2. With all buttons in the up position the brake shoes (91) should clear the drums (67) approximately $\frac{1}{8}$ inch.
3. Depress the stop button while observing the brake shoes. Both brake shoes must contact the drums at the same time and with equal pressure.

4. Adjustment is made by bending the spring arms.

Adjustment For Slow Take-Up Reel:

There are instances where the spring drive belt (61) stretches after a period of time. When this occurs the takeup torque will be insufficient to wind the tape properly on the take-up reel. In this case the belt should be replaced as follows:

1. Remove the rear escutcheon (6) and rear escutcheon plate (7). Remove the mechanism from the carrying case.
2. Loosen set screw (68) on brake drum (67) and slide take-up spindle (18) upward until the belt can be removed from the groove on the spindle.
3. Remove the belt from around the spindle and remove spindle. Remove the belt from around the pinch roller (17), and from the recorder.
4. Install new belt by reversing the above procedure.

Bias Adjustment:

Turn the recorder on and depress the "Record" button using no tape. To determine if the bias is within satisfactory limits without dismantling the unit, merely connect a VTVM from the top lug of the recording head to chassis. If 75 to 100 volts are present no adjustment is necessary.

If the readings are outside of this range, proceed as follows:

1. Try a new 6AQ5T, 12AX7, 6AQ5, and 5Y3.
2. If still not within range, remove the chassis and connect a low capacity VTVM from test point "A" to ground. Adjust trimmer (C4B) for maximum reading. Adjust trimmer (C4A) to obtain a reading of 2.25 volts. This provides the optimum in performance.

Neon Record Level Indicators:

The neon record indicator firing level adjust-

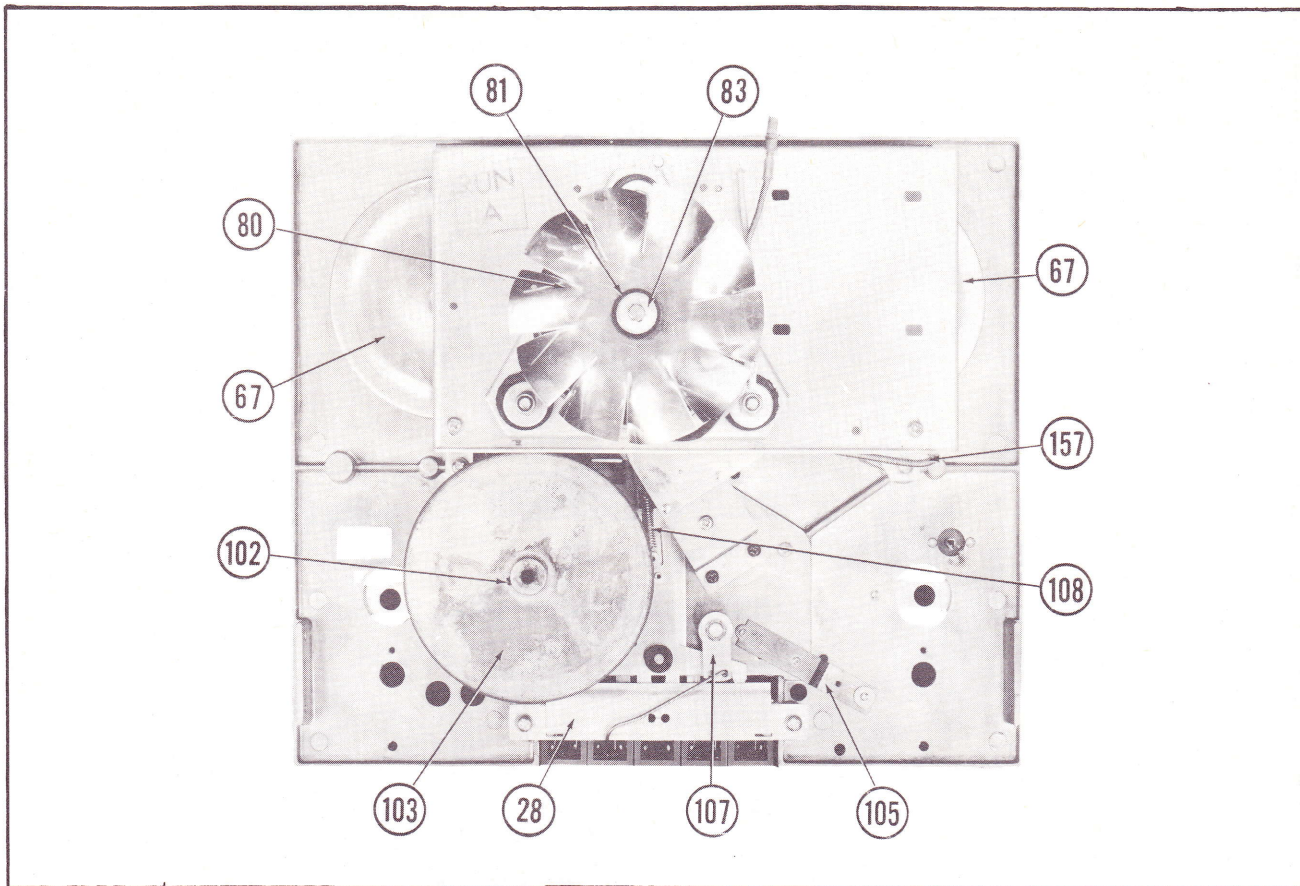

Figure 2

ment is required only if a bulb is replaced. The two neon indicators are adjusted for correct firing level by means of two trimmer capacitors, one for each indicator. Adjust as follows:

1. Turn recorder on and depress "Record" button.

2. Connect a short jumper lead across the bias oscillator coil, L1, to disable the oscillator.

3. Connect an audio oscillator, set at 1000 cycles, into the microphone input jack. Output of the audio oscillator should be approximately .01 volt. (A 1 volt output may be used with a 100 to 1 resistor reduction pad inserted between the audio oscillator and the Microphone jack).

4. Connect low capacity type AC VTVM to test point "B" (Junction of two 330K resistors, R28 and R29, mounted on a terminal strip near the volume control).

5. Adjust volume control to obtain a reading of 36 volts on the VTVM and leave control set and VTVM connected.

6. Disconnect shorting jumper from across bias oscillator coil.

7. Adjust "Normal" trimmer (C26A) fully clockwise and then turn slowly counterclockwise so that upon loosening the trimmer the "Normal" bulb barely lights. This adjustment must be made loosening the trimmer.

8. Again short out the bias oscillator coil and increase the volume control until a reading of 88 volts is obtained on the VTVM.

9. Remove short from bias oscillator coil.

10. Adjust the "Overload" trimmer (C26B) as in step 7 to just barely light the "Overload" indicator bulb.

IMPORTANT: Do not adjust the recording bias oscillator after setting the indicator light adjustments.

TROUBLES

Push Buttons Fail To Latch In Position:

Lock plate spring (27) loose or broken, resulting in lock plate (28) not being held against hinge bracket (26).

Fails To Erase:

1. Spring (57) loose or broken, not pulling the erase head forward against the tape.

2. Erase head not properly aligned. See "Erase Head Adjustment".

No Fast Forward Or Reverse:

1. Idler lever tension spring (90), may be loose or broken, not actuating idler lever.

2. Check drive belt (100) to see if it is properly

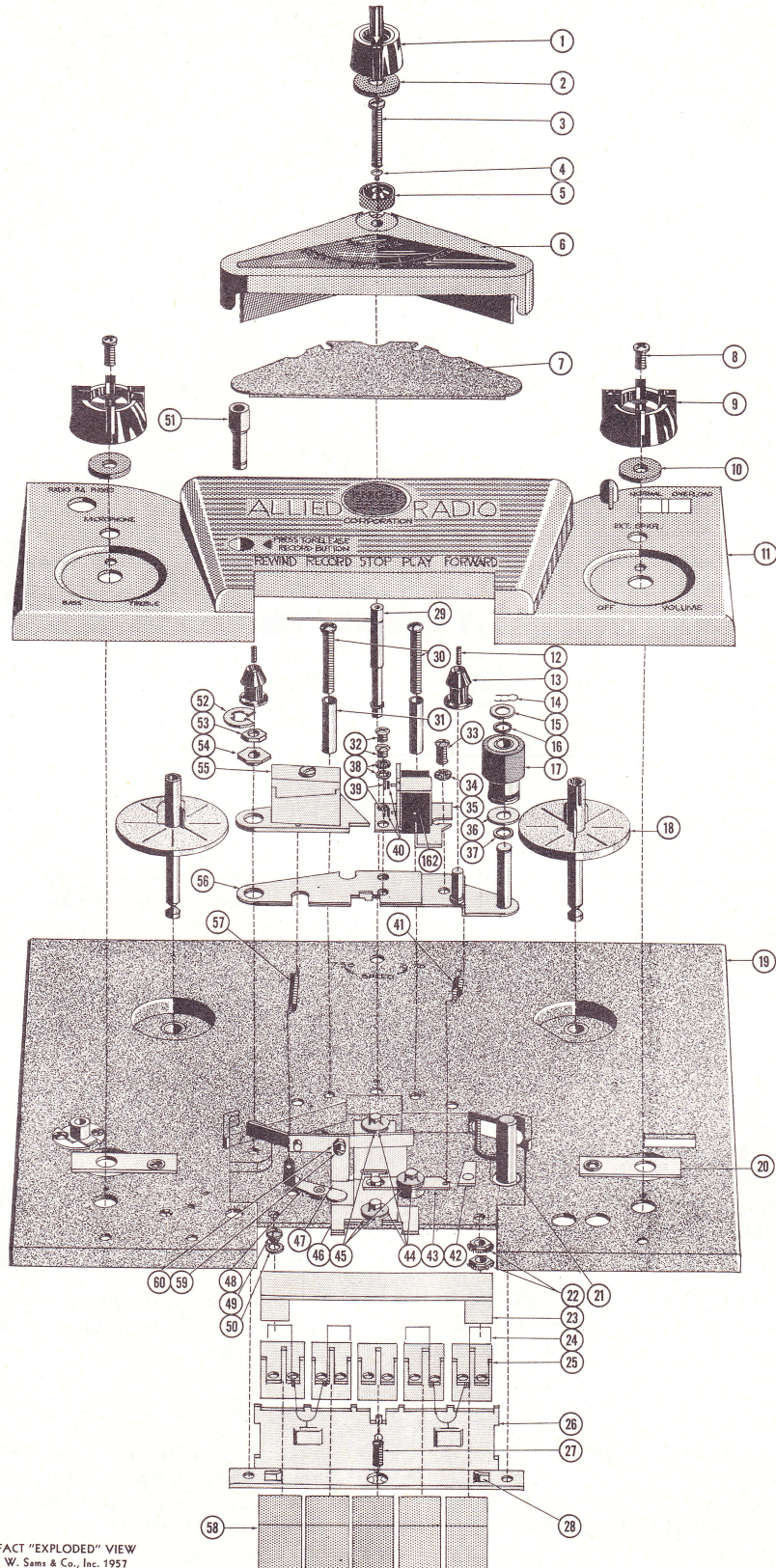

A PHOTOFACT "EXPLODED" VIEW
 © Howard W. Sams & Co., Inc. 1957

Figure 3A. Exploded View Of Parts Above The Baseplate

KNIGHT
MODELS 99RZ177, 99RZ936

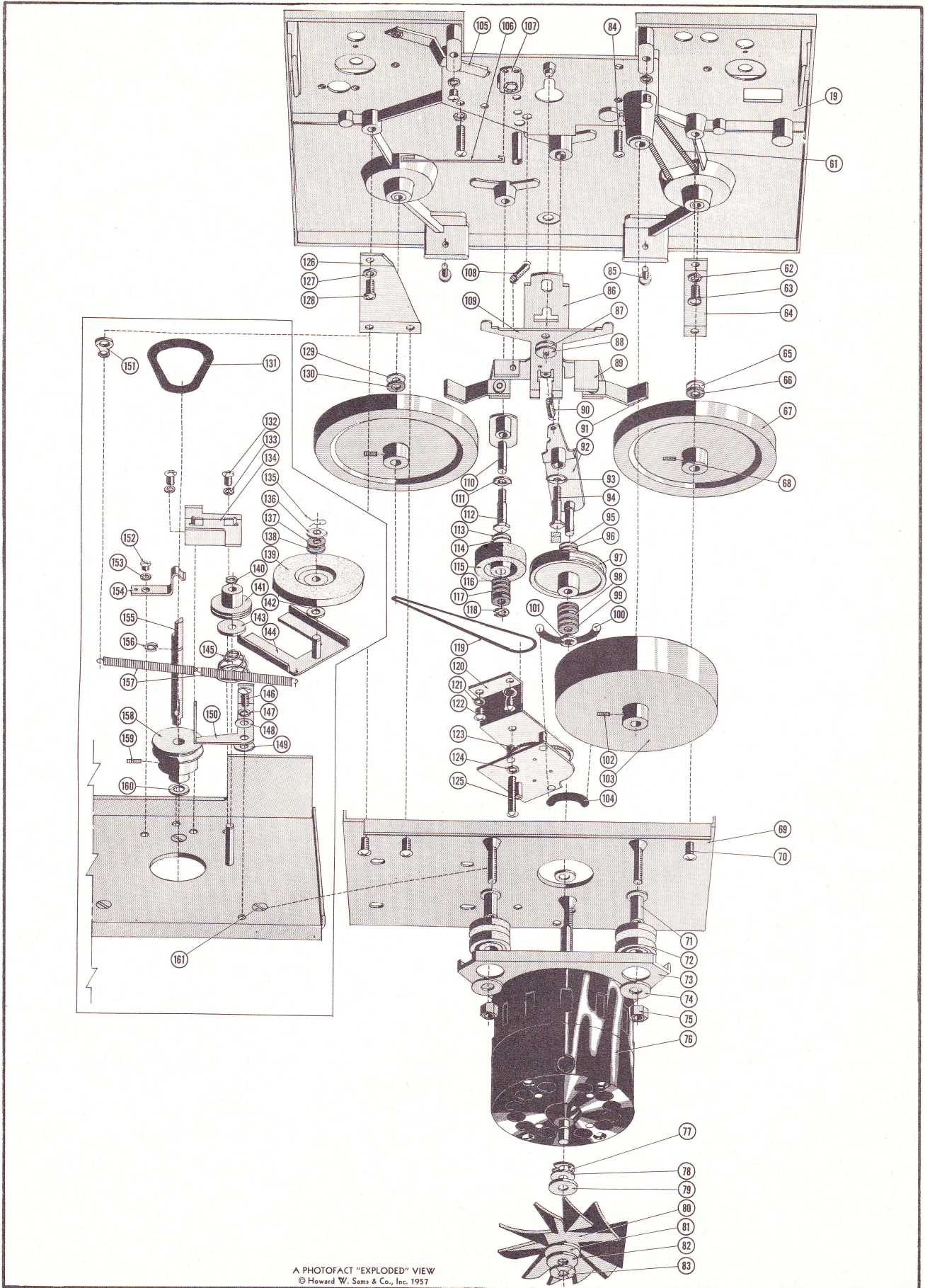

Figure 3B. Exploded View Of Parts Below The Baseplate

connected.

No Drive On Record Or Playback:

1. Idler tension spring (157) loose or broken, thereby not holding idler wheel (139) in proper contact with motor pulley (158) and flywheel (103).

2. Idler slide plate (144) binding on slide bushing (141) preventing idler wheel (139) from moving forward.

Tape Fails To Wind On Take-Up Reel During Record Or Playback:

1. Reel drive spring (61) loose or broken. See "Adjustment For Slow Take-Up Reel".

2. Brake drum shaft (Part of 18) binding. Clean foreign matter from bearing surface and lubricate.

Speed Variation Or WOW:

1. Check capstan (21), pinch roller (17), idler wheel (139), flywheel (103) and motor pulley (158) for foreign matter or oil on the driving surfaces. Clean these parts with a good cleaning fluid.

2. Check motor pulley (158) to see if it is secured to motor shaft.

3. Check idler tension spring (157) for holding idler wheel in firm contact with motor pulley (158) and flywheel (103).

4. Idler slide plate (144) binding on slide bushing (141) preventing idler wheel (139) from making positive contact with motor pulley and flywheel.

CLEANING

The capstan (21) record head (162) and pressure roller (17) are subject to an accumulation of tape coating residue, which is worn off the tape when it passes these parts. Use a soft cloth and alcohol to clean these parts.

CAUTION: Do not use a brush or metal object to clean the recording head as this could mar the metal pole piece.

LUBRICATION

All rotating parts are provided with generous size oilite bearings, which are factory lubricated and requires no further attention.

An occasional cleaning out of foreign matter under the plastic pushbutton cover is desirable, and a small drop of oil on the sliding lever members is advisable.

MECHANICAL PARTS LIST

Ref. No.	Part No.	Description
1	C-130253	Speed Shift Knob, Maroon
2	73-2254-3	Felt Washer
3		Screw #6-32 Phillips RHMS
4		Screw #4-36 Phillips OHMS
5	B-32.302-2	Timer Knob
6	D-13.292-2	Rear Escutcheon, Silver
7	B-19.975-3	Rear Escutcheon Plate, Gray
8		Screw #8-32 Phillips RHMS (2 Used)
9	C-13.254-13	Control Knobs, Gray
10	73-2254-3	Felt Washer (2 Used)
11	E-13.293-5	Front Escutcheon, Silver
12		#6-32 Bristol Head Set Screw (2 Used)
13	B-32.309	Tape Guide Post (Right)
	B-32.300D	Tape Guide Post (Left)
14	B-33.409	Hairpin Clip
15	73-2340	Linen Washer
16		Steel Washer
17	B-33.404E	Pinch Roller
18	B-13.262-8	Reel Pan (2 Used)
19	D-35.807-6G	Base Plate Assembly, Gray
20	B-19.985-1A	Jack Mounting Bracket (2 Used)
21	B-32.259-1G	Capstan Shaft
22	48-2219-1	#6-32 Hex. Nut (2 Used)
23	B-19-858	Push Button Retainer Bracket
24	B-31.337-B	Push Button Return Spring (2 Used)
25	B-19.876-D	Push Button Lever (5 Used)
26	B-19.859-1J	Hinge Bracket For Push Buttons
27	B-31.343-A	Lock Plate Spring
28	B-19.870-C	Push Button Lock Plate
29	35-851	Timer Shaft And Pointer Assembly

Ref. No.	Part No.	Description
30		Screw #6-32 Phillips RHMS
31	B-33.446	Spacer (2 Used)
32		Screw #6-32 RHMS (2 Used)
33		Screw #6-32 RHMS
34	73-2231-4	#6 Lockwasher, Int.
35	B-35.854	Head Mounting Bracket Assy.
36	73-2340	Linen Washer
37		Steel Washer
38	73-2231-4	#6 Lockwasher, Int. (2 Used)
39		#2-56 Hex Nut, C.P. (2 Used)
40	73-2233-1	#2 Int. Lockwasher (2 Used)
41	B-31.336-F	Pinch Roller Tension Spring
42	B-19.884-B	Hold Down Bracket
43	B-19.881-C	Playback Actuating Lever
44	B-33.412	Push-On Stud Nut, 3/16 Stud (3 Used)
45	73-2241-148F	Flat Washer
46	B-19.868A	Record Slide Plate
47	B-35.758	Playback Slide Plate Assy.
48	B-35.766-C	Record Actuating Lever Assembly
49		Screw #6-32 BHMS, Phillips
50	73-2231-4	#6 Int. Lockwasher Stl. C.P.
51	B-32.308-4	Record Lock Release Button
52	33.415	"E" Retaining Ring
53	48-1C-13-1	#6-32 Hex Nut, Steel C.P.
54	B-32.260-D	Tape Guide Post Spacer
55	B-35.794	Erase Head And Plate Assy.
56	B-35.824-B	Pinch Roller Plate Assembly
57	B-31.347-B	Erase Head Tension Spring
58	B-35.755-5	Push Button Assembly, Gray (5 Used)
59		#6-32 RHMS Steel C.P.
60	48-410-1	#6-32 Locknut
61	B-31.351A	Reel Drive Spring (Tension)
62	73-2231-5	#8 Int. Lockwasher

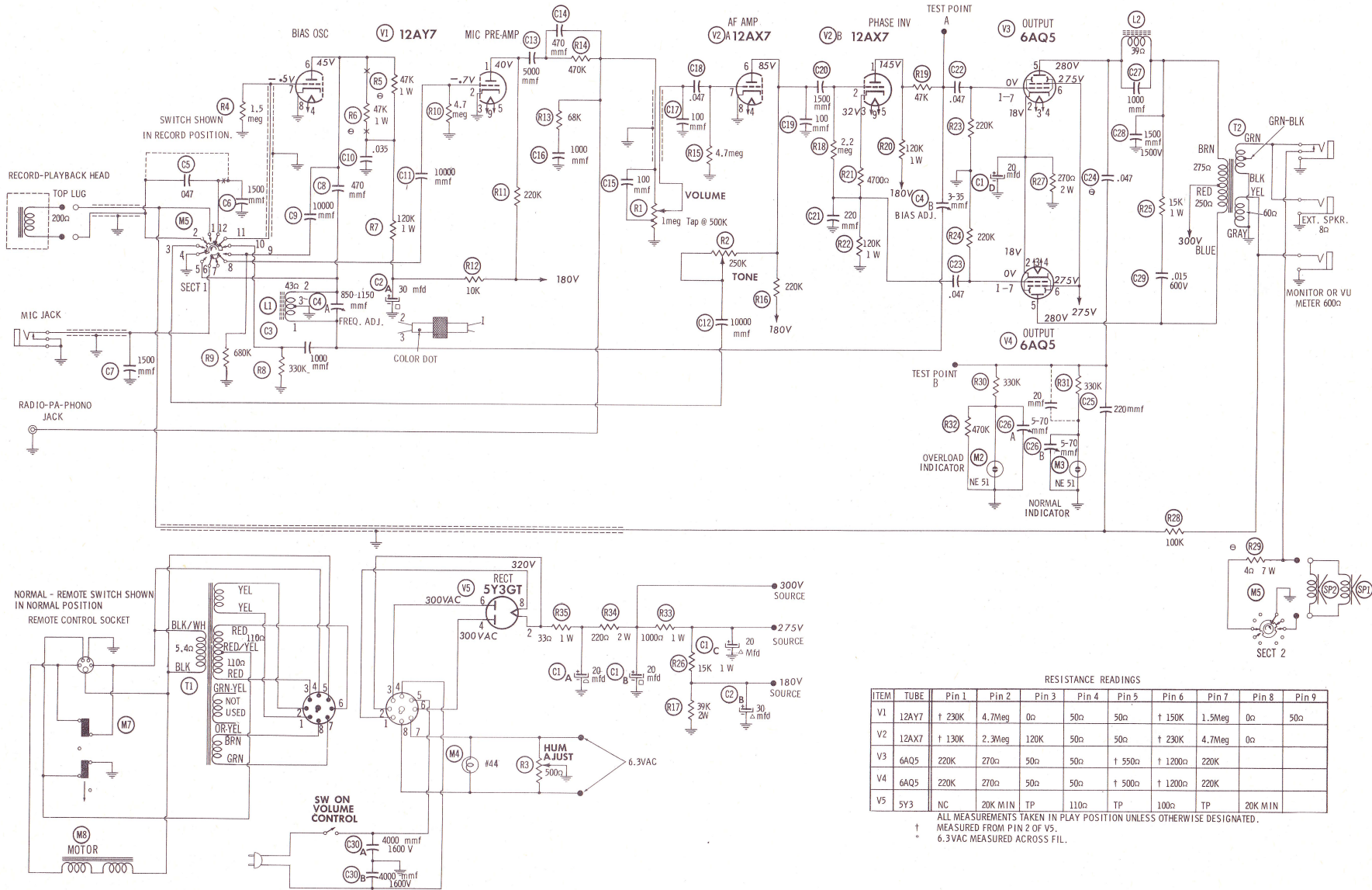

A PHOTOFAC STANDARD NOTATION SCHEMATIC
 Howard W. Sams & Co., Inc. 1957

KNIGHT
 MODELS 99RZ177, 99RZ936

PARTS LIST AND DESCRIPTIONS TUBES (GENERAL ELECTRIC, SYLVANIA)

ITEM No.	USE	TYPE	NOTES
V1	Bias Osc. & Mic. Preamp.	12AX7	
V2	A.F. Amp. & Phase Inv.	12AX7	
V3	Output	6AQ5	
V4	Output	6AQ5	
V5	Rectifier	5Y3GT	

ELECTROLYTIC CAPACITORS

ITEM No.	RATING		REPLACEMENT DATA			
	CAP.	VOLT.	AEROVOX PART No.	CORNELL-DUBILIER PART No.	MALLOYRY PART No.	SPRAGUE PART No.
C1A	20	450	AFH4-67	D0520	FP444	Q-340
C1B	20	450				
C1C	20	450				
C1D	20	25				
C2A	30	250	AFH2-27	B0220	FP135 TCS8	D110 MTD-US10
C2B	30	250				

FIXED CAPACITORS

Capacity values given in the rating column are in mfd. for Paper Capacitors, and in mmfd. for Mica and Ceramic Capacitors.

ITEM No.	RATING		REPLACEMENT DATA						NOTES
	CAP.	VOLT.	AEROVOX PART No.	CENTRALAB PART No.	CORNELL-DUBILIER PART No.	ERE PART No.	MALLOYRY PART No.	SPRAGUE PART No.	
C3	1000		SH1000	D8-102	LT9T1	GP-1000	UC-521	5GA-D1	Dual
C4A	850-								
C4B	1150								
C5	3-.35								
C6	5047	200	BPD-05	DF-503	CUB4S47	GP-1500	GEM-4147	2TM-S47	
C7	1500		SH1500	D6-152	LT6D15	GP-1500	UC-5215	5GA-D15	
C8	470		SH470	D6-471	LT6T47	GP-470	UC-5347	5GA-T47	
C9	100000		BPD-01	DD-103	BYA6SI	ED-01	DC511	5HK-S1	
C10	.035	400							
C11	10000		BPD-01	DD-103	BYA6SI	ED-01	DC511	5HK-S1	
C12	10000		BPD-01	DD-103	BYA6SI	ED-01	DC511	5HK-S1	
C13	5000		BPD-005	DD-502	BYA10D5	ED-005	DC525	5HK-D5	
C14	470		SH470	D6-471	LT6T47	GP-470	UC-5347	5GA-T47	
C15	100		SH100	D6-101	LT6T1	GP-100	UC-531	5GA-T1	
C16	1000		SH1000	D6-102	LT6D1	GP-1000	UC-521	5GA-D1	
C17	100	200	SH100	D6-101	LT6T1	GP-100	UC-531	5GA-T1	
C18	.047		BPD-05	DF-503	CUB4S47	GP-100	GEM-4147	2TM-S47	
C19	1000		SH1000	D6-102	LT6D15	GP-1500	UC-5215	5HK-D15	
C20	1500		SH1500	D6-152	LT6D15	GP-1500	UC-5215	5HK-D15	
C21	220		NPO-S1220	D6-221	LI0T22			MS-322	10%
C22	.047	400	BPD-05	DF-503	CUB4S47			4TM-S47	
C23	.047	400	BPD-05	DF-503	CUB4S47			4TM-S47	
C24	.047	400	BPD-05	DF-503	CUB4S47			4TM-S47	
C25	220		NPO-S122	D6-221	LI0T22			MS-322	10% Dual
C26A	5-70								
C27	1000	1500	1464-001	DD30-152	IR5D1	HD15-1500	DC30215	MS-21	10%
C28	1500		HVD-15-1500	DD16-153	HVC16D15	ED-015	GEM-6115	6TM-S15	Dual
C29	.015	600	BPD-015						
C30A	4000	1600							
C30B	4000	1600							

① Some versions use a .035 capacitor @ 600V in this application.

CONTROLS

ITEM No.	RATING		REPLACEMENT DATA				INSTALLATION NOTES
	RESIST.	WATTS	CENTRALAB PART No.	CLAROSTAT PART No.	IRC PART No.	MALLOYRY PART No.	
R1A	1Meg	1/2	BT-71	A47F5-1Meg	Q19-137X	UT-443	Volume Tap @ 500K
B	Shaft		Not Req.	FS-3	Not Req.	Not Req.	
C	Switch		KB-1	SWE-12	76-1	US-26	Tone
R2A	250K		B-50	A47-250K-S	Q11-130	U46	
B	Shaft		Not Req.	FS-3	Not Req.	Not Req.	
R3A	500Ω		AB-4	A47-500-S	Q11-103	U2	Hum Adjust
B	Shaft		AK-1	FKS-1/4	RQ	Not Req.	

CHASSIS—TOP VIEW

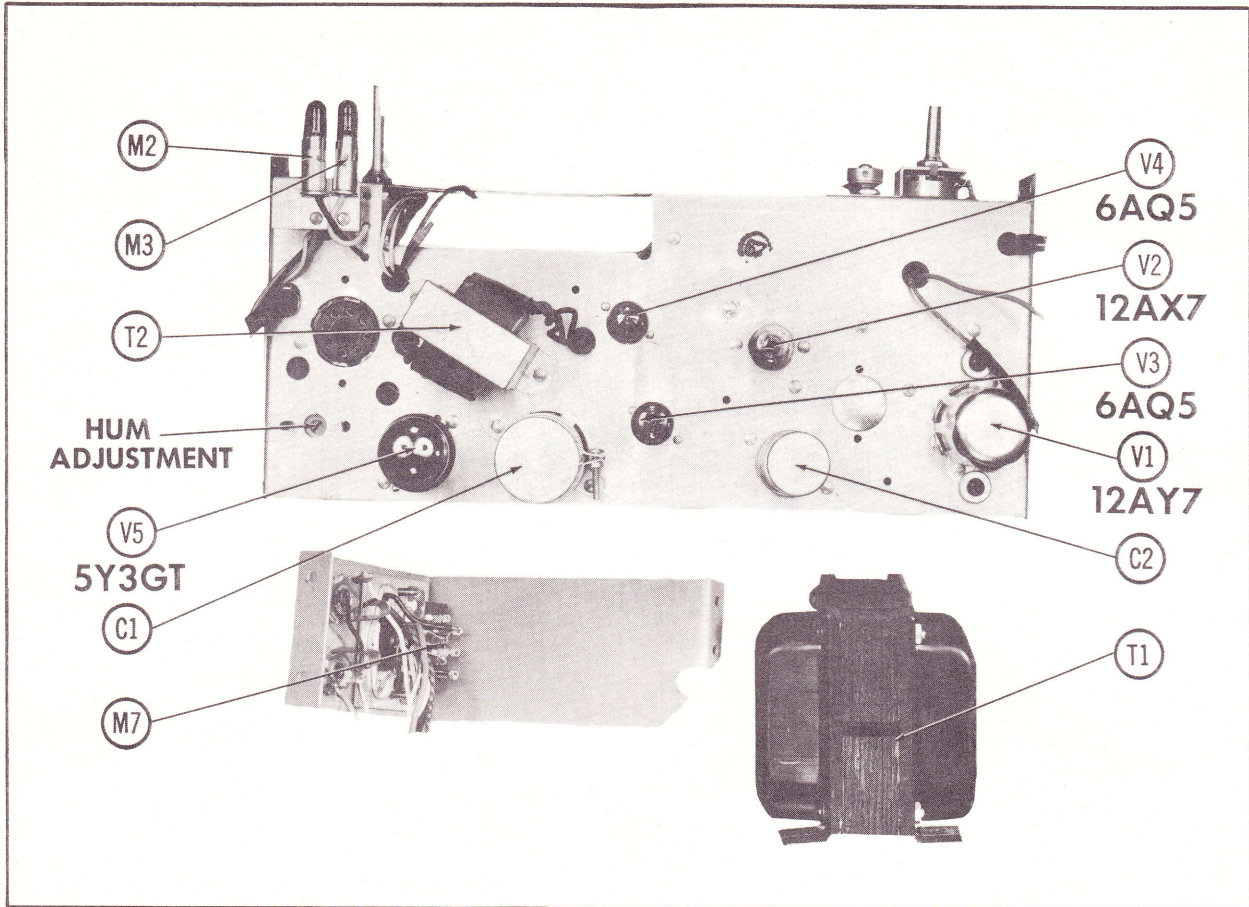

PARTS LIST AND DESCRIPTIONS (Continued)

RESISTORS

All wattages 1/2 watt, or less, unless otherwise listed.

ITEM No.	RATING		REPLACEMENT DATA		NOTES
	OHMS	WATT	KNIGHT PART No.	IRC PART No.	
R4	1.5Meg		BTS-1, 5Meg	BTA-120K	
R5	47K	1	BTA-47K	BTS-4700	
R6	47K	1	BTA-47K	BTA-120K	Note 1
R7	120K	1	BTA-120K	BTS-220K	Note 1
R8	330K	1	BTS-330K	BTS-220K	
R9	680K	1	BTS-680K	BTA-15K	
R10	4.7Meg	1	BTS-4.7Meg	BTA-15K	
R11	220K	2	BTS-220K	ETS-270	
R12	10K		BTS-10K	ETS-100K	
R13	68K	4	BTS-68K	PW7-4	
R14	470K		BTS-470K	BTS-330K	
R15	4.7Meg		BTS-4.7Meg	BTS-330K	
R16	220K		BTS-220K	BTS-470K	
R17	39K	2	BTS-39K	ETA-1000	
R18	2.2Meg		BTS-2.2Meg	ETA-220	
R19	47K		BTS-47K	ETA-33	

Note 1. Some versions may use a single 22K 1 Watt resistor.

Note 2. Some versions may use a 3.3K 7 Watt resistor.

TRANSFORMER (POWER)

ITEM No.	RATING		REPLACEMENT DATA						
	PRI.	SEC. 1	SEC. 2	Part No.	Holderson Part No.	Merit Part No.	RCA Type No.	Stencor Part No.	Thornderson Part No.
T1	117VAC ④. 59A	600VCT ⑤. 075A	5V ②. 2A	D-9278-0	P9304 ②			22R04 ① ②	

* This Winding Not Used.
① Use Universal Mfg. Bracket.
② Tape Center Tap On 6. 3V Winding.

TRANSFORMER (AUDIO OUTPUT)

ITEM No.	IMPEDANCE		REPLACEMENT DATA				NOTES
	PRI.	SEC.	KNIGHT PART No.	Stencor Part No.	Thornderson Part No.	Triad Part No.	
T2	1500Ω	3-4Ω	C-9277-B				* Note - Center Tap Not Used.

COILS (RF-IF)

ITEM No.	USE	REPLACEMENT DATA		NOTES
		KNIGHT PART No.	MEISSNER PART No.	
L1	Bias Osc.	B-1, 657	MERIT PART No.	
L2	Tuned Coil	B-1, 656	MILLER PART No.	8. 5 Millihenries 8. 2 Millihenries

SPEAKER

ITEM No.	TYPE	REPLACEMENT DATA		NOTES
		KNIGHT PART No.	QUAM PART No.	
SP1	5" x 7" PM	30-341-2	57A126	
SP2	5" x 7" PM	30-341-2	57A126	

MISCELLANEOUS

ITEM No.	PART NAME	KNIGHT PART No.	NOTES
M1	Erase Head Assy.	B-35, 794	
M2	Indicator Light	45-2036-1	Neon
M3	Indicator Light	45-2036-1	Neon
M4	Pilot Light		#44
M5	Switch	B-11, 247	Function - (Rotary Wafer Type)
M6	Switch Lever Assy.	B-35, 859-1	
M7	Switch		Normal - Remote (Slide Type - DPDT)
M8	Motor		

CHASSIS—BOTTOM VIEW

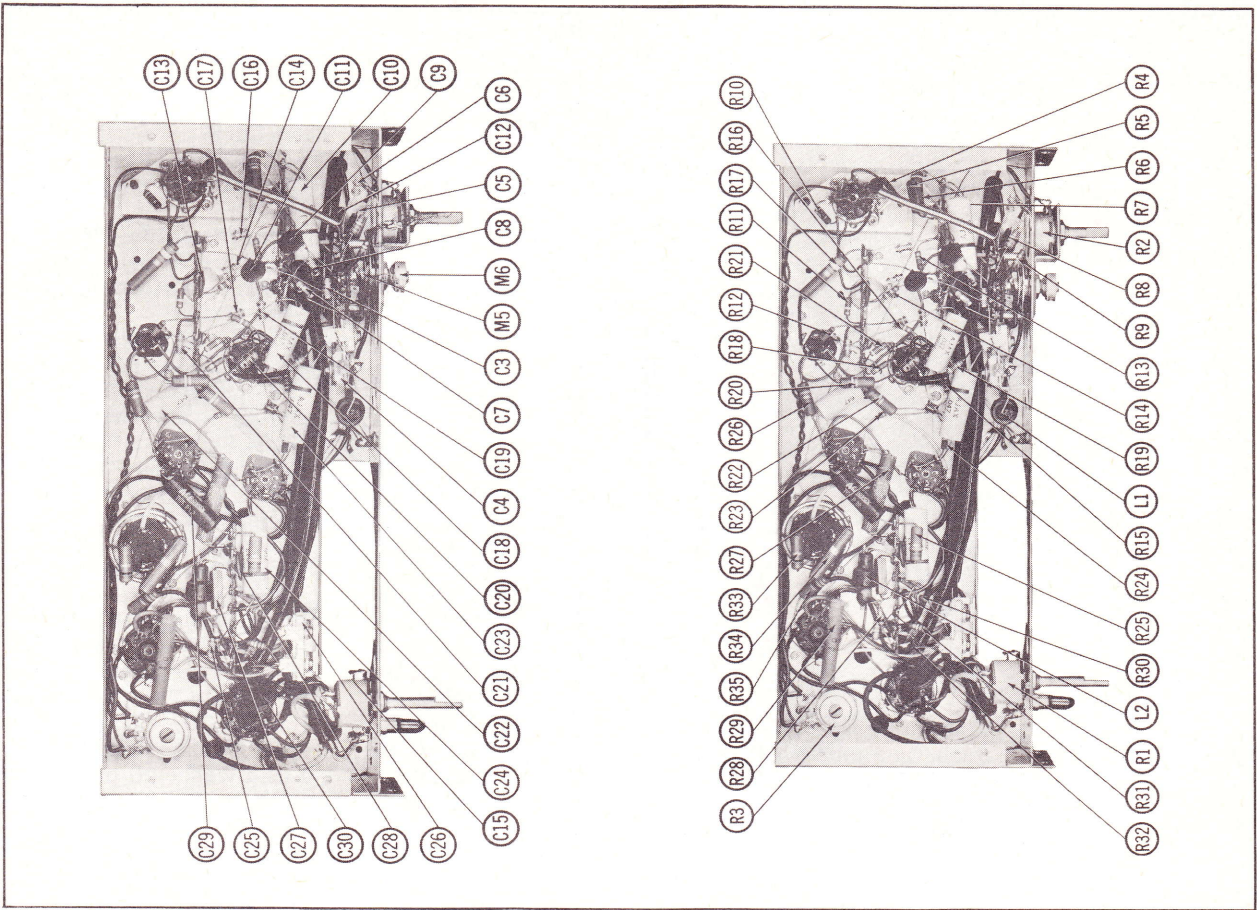

MODELS 99RZ177, 99RZ936

KNIGHT

MECHANICAL PARTS LIST (CONTINUED)

Ref. No.	Part No.	Description
63		#8-32 Screw, RHMS Phillips
64	B-19, 862C	Angle Bracket For Mounting Drive Assembly
65	B-28, 163	Linen Washer
66	73-2241-134	Flat Washer (1 or 2 Used)
67	C-35, 823-1E	Brake Drum And Bushing Assembly (2 Used)
68		#8-32 BHM Screw (2 Used)
69	D-35, 753-1	Drive Mounting Plate
70		#8-32 BHM Screw
71		Spacer, Motor Mounting (Part of Item 72)
72	B-28, 159	Shock Mount
73	C-19, 837-F	Motor Adapter Plate
74	B-33, 411-A	Flat Washer
75	48, 409-1	Hex Nut
76	D-36, 153-E	Motor, Round Type (Fasco)
	D-36, 154G	Motor, Square Type (GI and Alliance)
77	B-33, 418	Truarc Retaining "E" Ring
78	73, 2241-143	Flat Washer
79	73-2254-3	Felt Washer
80	C-119, 887-1	Fan Blade
81	73-2254-3	Felt Washer
82	73-2241-143	Flat Washer
83	33, 415	Push-On Fastener (Presthole)
84		#8-32 RHM Screw, Phillips (2 Used)
85		#8-32 RHM Screw, Phillips (2 Used)
86	C-35, 835	Brake Slide Plate Assembly
87	B-28, 163	Linen Washer
88	B-33, 412	Push-On-Stud Nut, 3/16" Stud
89	B-35, 764	Pressure Pad Spring Assy.
90	B-31, 339-C	Idler Lever Tension Spring
91	B-31, 335A	Brake Pad, Felt (2 Used)
92	B-35, 834-2	Idler Lever Assembly
93		Bent Washer
94	B-32, 275-1E	#8-32 HH Shoulder Screw
95	28, 173	Phenolic Washer
96	28, 173	Phenolic Washer
97	B-33, 406-D	Idler Drive Sheave
98	73-2254-6	Felt Washer (1 or 2 Used)
99	73-2241-150	Steel Washer (1 or 2 Used)
100	B-28, 181	Idler Drive Belt
101	B-33, 418	Truarc Retaining "E" Ring
102		#8-32 BHS Screw
103	C-13, 257-1C	Flywheel
104	B-28, 181	Idler Drive Belt
105	B-35, 774	Record Interlock Assembly
106	B-31, 333	Switch Arm Link
107	B-35, 859-1	Switch Lever Assembly
108	B-31, 338-B	Brake Return Spring
109	B-35, 759-1	Shift Plate Assembly
110	B-35, 757D	Sub Idler Plate Assembly
111		Bent Washer
112	B-32, 275-1E	#8-32 HH Shoulder Screw
113	28, 173	Phenolic Washer

Ref. No.	Part No.	Description
114	28, 173	Phenolic Washer
115	B-35, 405-F	Sub Idler
116	73-2254-6	Felt Washer (1 or 2 Used)
117	73-2241-150	Flat Washer, Steel (1 or 2 Used)
118	B-33, 418	Truarc Retaining "E" Ring
119		Timer Drive Belt
120	D-33, 445	Gear Train Mounting Bracket, Tape Index
121	73-2331-4	#6 Int. Lockwasher
122		#6-32 Phillips RHM Screw
123	D-33, 445-A	Tape Index Gear Train
124	73-2331-4	#6 Int. Lockwasher
125		#6-32 Phillips RHM Screw
126	B-19, 863	Drive Mounting Plate Bracket
127	72-2231-5	#8 Int. Lockwasher
128		#8-32 RHM Screw, Phillips
129	B-28, 163	Linen Washer
130	73-2241-143	Flat Washer, Steel (1 or 2 Used)
132		#6-32 Phillips RHM Screw (2 Used)
133	73-2231-4	#6 Int. Lockwasher
134	51-3182	Shift Plate For Fast Speed
135	B-33, 409	Hairpin Clip
136	73-2241-150	Steel Washer (1 or 2 Used)
137	B-28, 163	Linen Washer (1 or 2 Used)
138	73-2238-49	Phenolic Washer (1 or 2 Used)
139	B-33, 408C	Rubber Bonded Idler Wheel 2 1/2" Dia.
140	B-33, 407-1	"C" Washer
141	B-32, 264-F	Idler Slide Bushing
142	B-28, 163	Linen Washer
143		Steel Washer
144	B-35, 768-A	Idler Slide Plate Assembly
145	B-31, 327-D	Idler Lift Spring
146		#8-32 RHM Screw
147	73-2241-150	Steel Washer
148	B-32, 291-1	Shoulder Washer
149		Steel Washer
150	110-47	Idler-Throw-Out-Lever
151		Idler Tension Spring Clip
152		#6-32 RHM Screw, Phillips
153	73-2231-4	#6 Int. Lockwasher
154	B-19, 961	Speed Control Shaft Detent Spring
155	C-35, 816-1	Speed Control Shaft Assembly
156	33, 469	Truarc Retaining Ring
157	B-31, 324-A	Idler Tension Spring (2 Used)
158	B-32, 288-D	Motor Drive Pulley
159		#8-32 B. H. S. Screw
160	73-2238-49	Phenolic Washer
161		Motor Mounting Screw (3 Used)
162	C-36, 156-E	Tape Recording Head/Shure TR16A