

KOLSTER-BRANDES "CAVALCADE"

Circuit.—The first detector oscillator valve, 15 D1 or 15 PGA (V1), is preceded by a band-pass aerial coupling. Bias is by A.V.C. with cathode limiting resistance and the coupling to the next valve is a band-pass I.F. transformer (frequency 150 KC).

The I.F. valve, 91D2 or 13VPA (V2), is

followed by a second band-pass I.F. transformer.

The second detector and I.F. amplifying valve, 11D3 or 13D1A (V3), uses one diode anode for L.F. purposes and the other for A.V.C. The I.F. coupling to the triode section is by resistance-capacity filter (R13, C10),

and the grid leak forms the volume control potentiometer. Tone is controlled by a variable condenser across the grid leak.

The output valve is a pentode, 7D3 or 40PPA (V4).

(Continued on next page.)

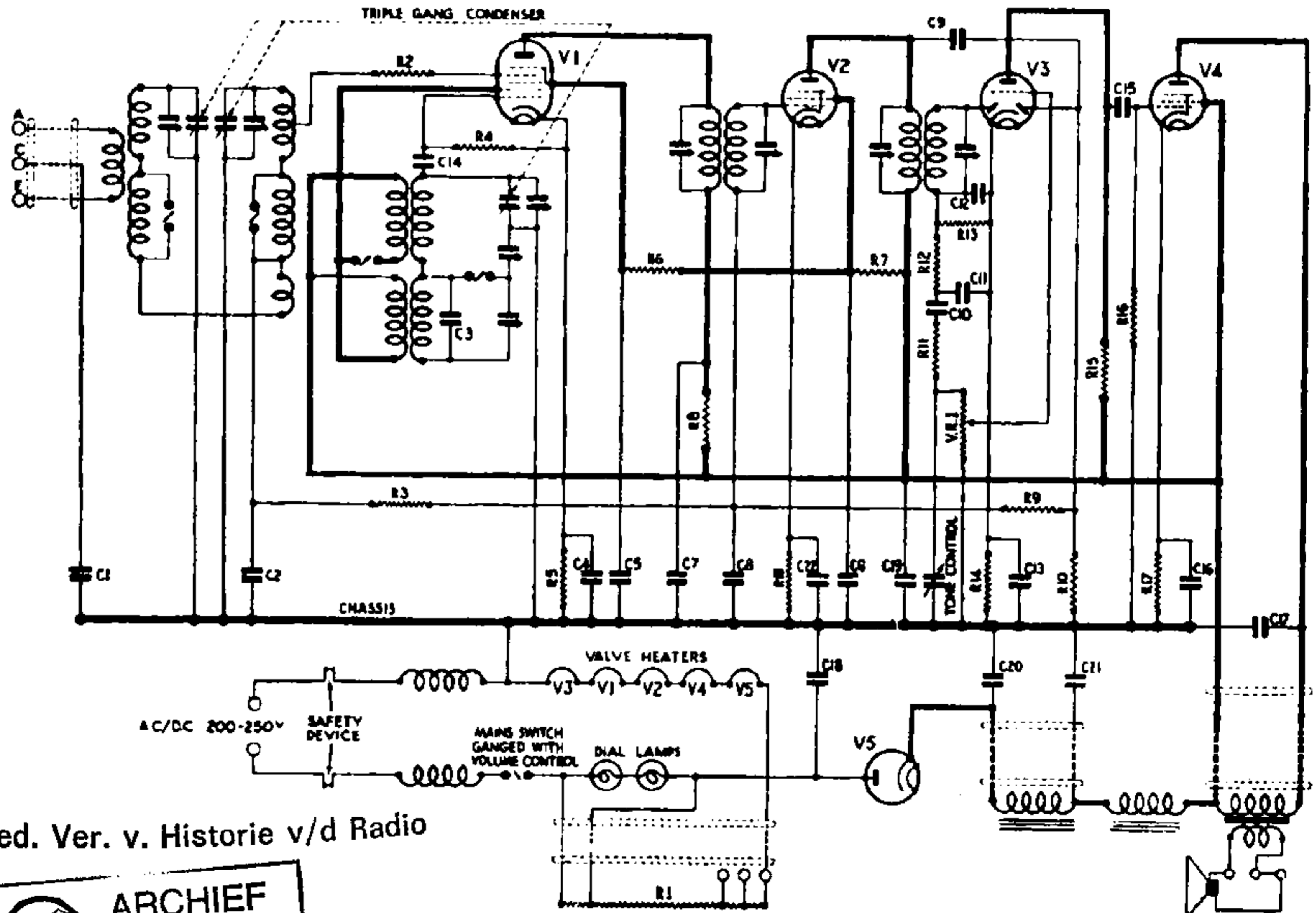

The Cavalcade is a straightforward A.C.-D.C. super-het utilising 5 valves in all. Note the precautions to prevent hum.

Ned. Ver. v. Historie v/d Radio

K.B. CAVALCADE A.C. SUPERHET (Contd.)

Mains equipment consists of an H.F. choke in each mains lead, a half-wave rectifying valve, 1D5 or 40SUA, and both a choke and the speaker field in the positive H.T. lead for smoothing.

The heaters are wired in this order from chassis:—V3, V1, V2, V4 and rectifier.

Special Notes.—Dial lamps are 6.2 volts .3 amp. type.

As on all A.C.-D.C. sets the chassis may be live with relation to earth both on A.C. and D.C. mains.

Quick Tests.—Between the following ter-

minals and chassis (looking from the rear):—
Smoothing choke: Right (red and black), H.T. unsmoothed, 230 v.; left (black) 215 v.;
Output transformer: Left, top 1, black, 215 v.; 2, blue, V4 anode, 140 v.; 3 and 4, red, HT smoothed, 150 v.

Revealing Chassis.—There is no need to remove the chassis for examination, simply remove the wood screws round the board on the bottom of the cabinet.

General Notes.—The mains connector at the back of the chassis is a safety device. To allow tests to be carried out a special key can be supplied by the makers.

Extra Speaker Connections.—Use a speaker with a speech coil of between 2 and 4 ohms with leads soldered to tags B and G on the transformer.

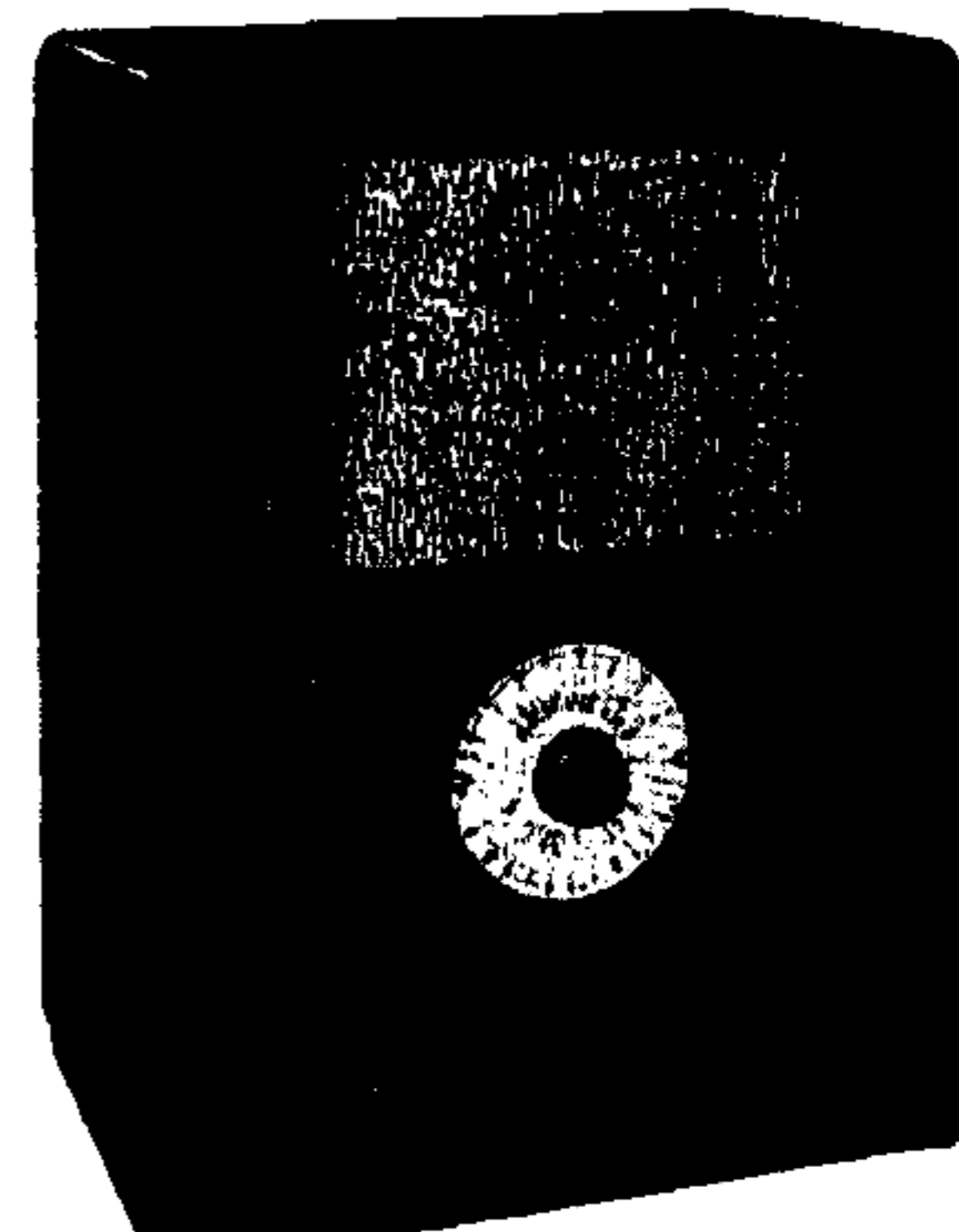

The K.B. Cavalcade.

CONDENSERS

C.	Purpose.	Val.
1	Series earth	.01
2	Band pass coupling	.02
3	L.W. osc. pad (twisted wire)	9mmf.
4	V1 cathode by-pass	.5
5	V1 aux. grid by-pass	el. 4 (250 v.)
6	V2 aux. grid by-pass	.1
7	V1 anode decoupling	.01
8	V2 grid decoupling	.1
9	L.F. feed to A.V.C. diode	9 mmf.
10	L.F. coupling to triode grid	.02
11	H.F. by-pass	.0001
12	H.F. by-pass	.0001
13	V3 cathode by-pass	el. 25 (25 v.)
14	V1 osc. grid	.0001
15	L.F. coupling to V4	.02
16	V4 cathode by-pass	el. 25 (25 v.)
17	Tone compensating V4 anode	.02
18	By-pass from rectr. anode	.01
19	H.T. smoothing	el. 4 (250 v.)
20	H.T. smoothing	el. 8 (250 v.)
21	H.T. smoothing	el. 8 (250 v.)
22	V2 cathode by-pass	.1

Bracketed figures are working voltages.

RESISTANCES

R.	Purpose.	Ohms.
1	Mains adjustment to heaters	635
2	V1 grid stabiliser	400
3	Decoupling V1 grid	100,000
4	V1 osc. grid leak	25,000
5	V1 cathode bias	150
6	Decoupling V1 aux. grid	15,000
7	Decoupling V2 aux. grid	5,000
8	Decoupling V1 anode	1,000
9	Decoupling A.V.C. line	100,000
10	A.V.C. diode load	500,000
11	H.F. stopper	1 meg.
12	H.F. stopper	100,000
13	Diode load	500,000
14	V3 cathode bias	10,000
15	V3 anode coupling	250,000
16	V4 grid leak	250,000
17	V4 cathode bias	500
18	V2 cathode bias	300
--	Speaker field	1,000

All resistances except R1 are .5 watt.

VALVE READINGS

Valve.	Type.	Electrode.	Volts.	M.A.
1	15D1 or 18PGA (7)	anode	125	5
		aux.grid	55	7.5
		osc.anode	120	5
2	9D2 or 13VPA (7)	anode	140	8
		aux.grid	100	2
3	11D3 or 13DHA	anode	80	.1
		anode	128	.35
4	7D3 or 40PPA	anode	140	8
		aux.grid	140	8

First valves named are primary, alternatives are Coscor.

V1, V2 and V3 have 13 volt heaters.

V4 and the rectifier have 40 volt heaters.

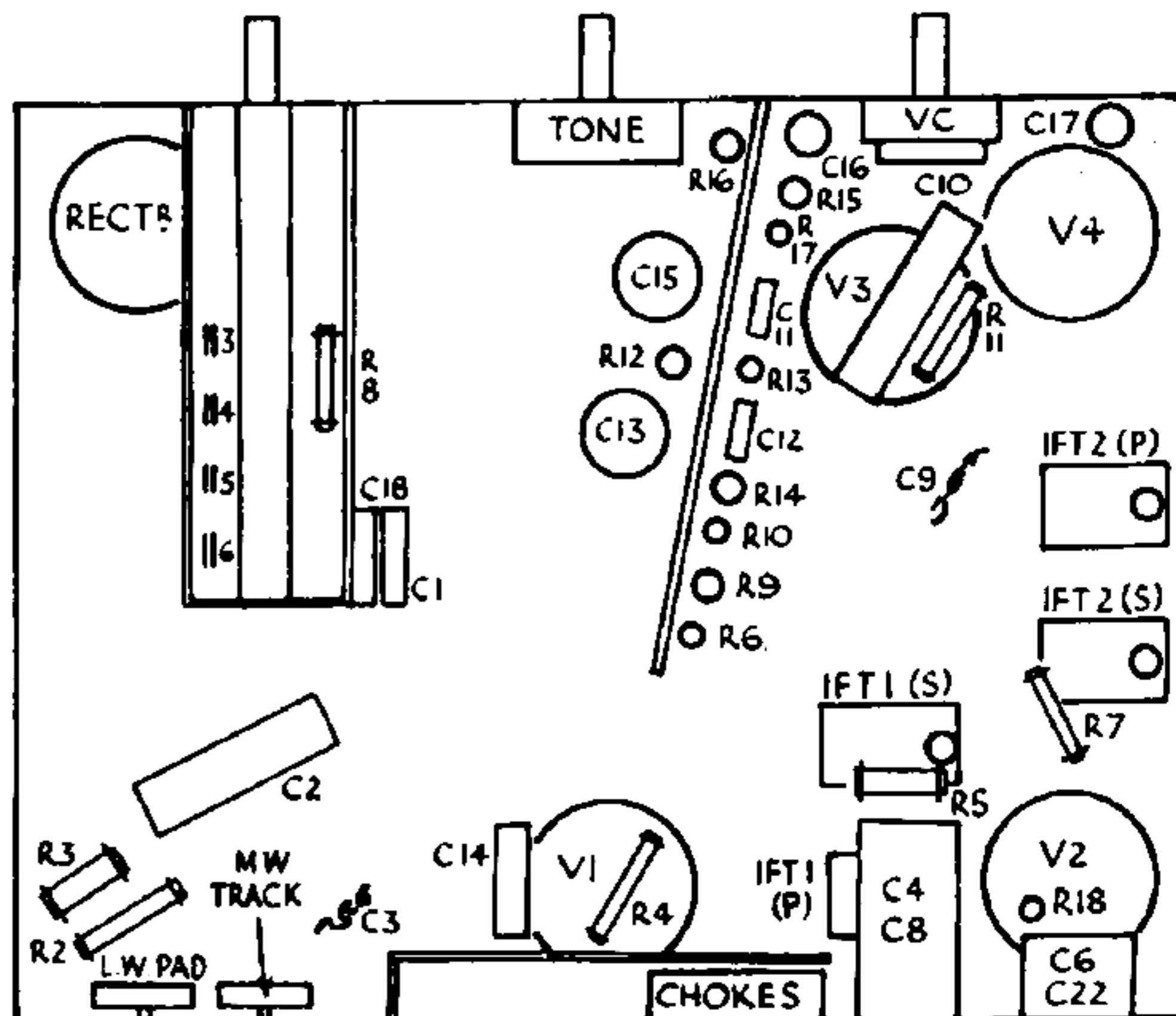
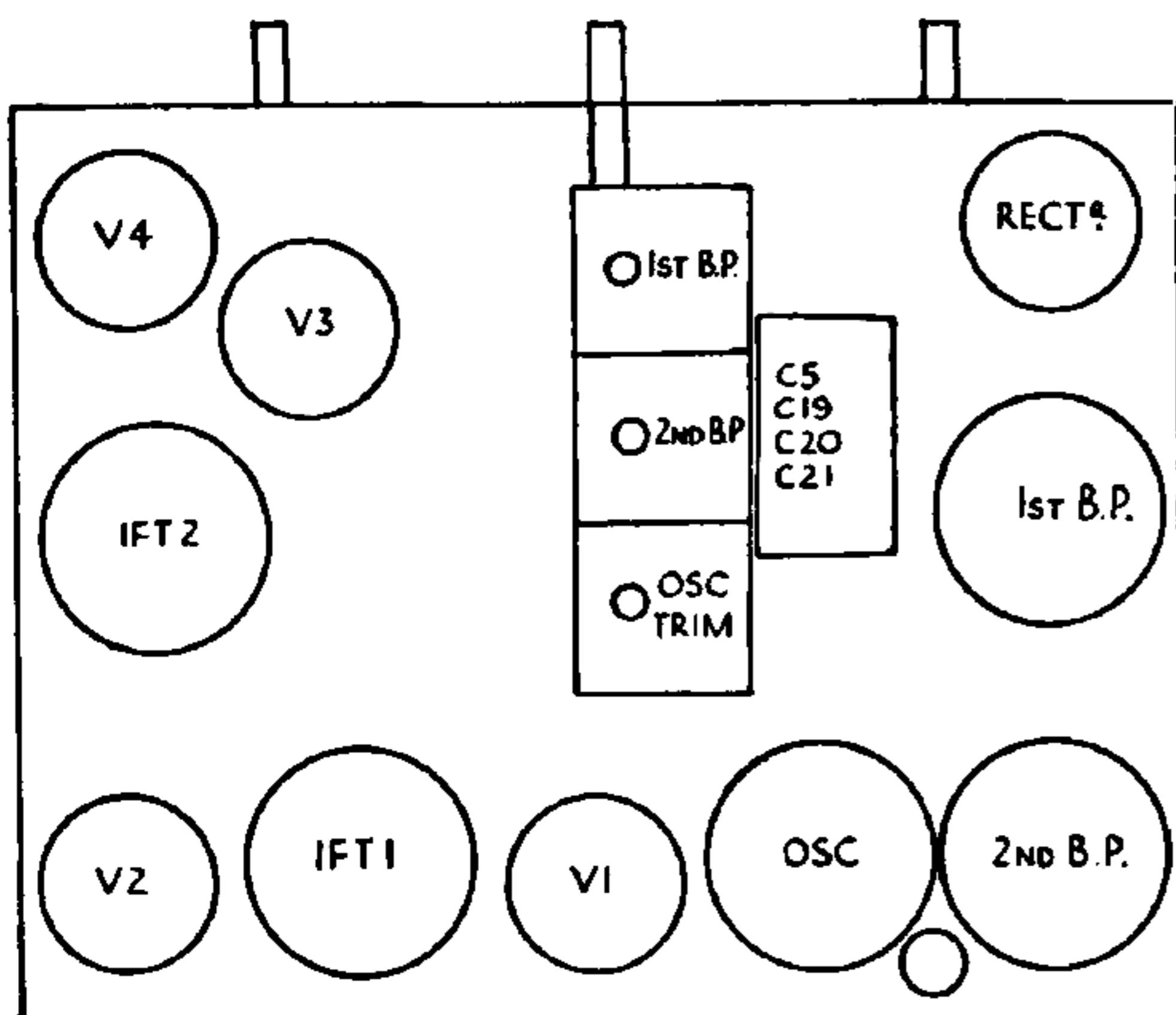

The underside of the Kolster Brandes chassis is made accessible simply by removing the wood board in the bottom of the cabinet.