

Lafayette

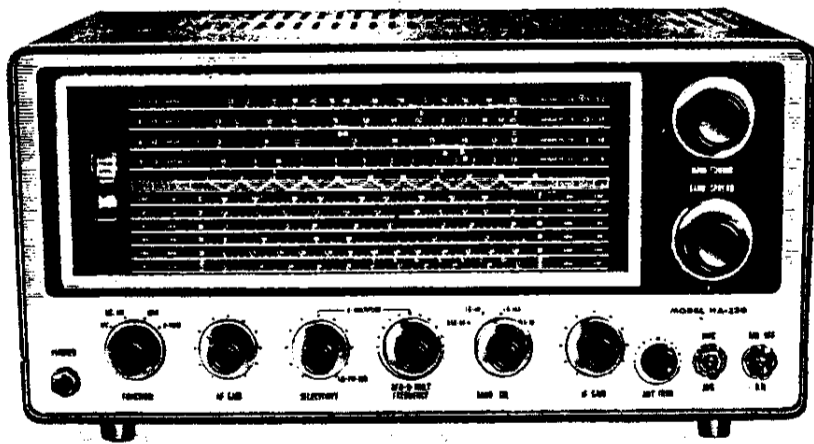

MODEL HA-230

(Stock No. 99-2522WX)

COMMUNICATIONS RECEIVER

INSTALLATION AND OPERATING MANUAL

TECHNICAL SPECIFICATIONS

FREQUENCY RANGES..... BAND A 550 - 1600 Kcs
BAND B 1.6 - 4.8 Mcs
BAND C 4.8 - 14.5 Mcs
BAND D 10.3 - 30 Mcs

BANDSPREAD..... Calibrated Electrical Bandspread
80 and 40 meters, 5 Kcs per division
20 and 15 meters, 20 Kcs per division
10 meters, 50 Kcs per division

ANTENNA INPUT..... 50 - 400 ohms impedance

AUDIO POWER OUTPUT..... 1.5 watts

SENSITIVITY..... 1 μ v for 10 db S/N Ratio

SELECTIVITY..... \pm 10 Kc at -60 db (\pm 2 Kc at -6 db) without Q-Multiplier
 \pm 0.8 Kcs at -6 db with Q-Multiplier

SPEAKER OUTPUT..... 4 or 8 ohms

HEADPHONE OUTPUT..... Low Impedance

POWER CONSUMPTION..... 50 watts at 117 volts AC, 60 cps

TUBE COMPLEMENT..... V1 - 6BA6 RF Amplifier
V2 - 6BE6 Mixer
V3 - 6BE6 HF Oscillator
V4 - 6AV6 Q-Multiplier-BFO
V5 - 6BA6 1st IF Amplifier
V6 - 6BA6 2nd IF Amplifier
V7 - 6AV6 Detector, 1st AF Amplifier, ANL, AVC
V8 - 6AQ5 Audio Output
V9 - 5Y3 Rectifier

DIMENSIONS..... 7" H x 15" W x 10" D

WEIGHT..... 21 lbs

UNPACKING INSTRUCTIONS

After unpacking the receiver, carefully check for possible damage which may have occurred in transit. Should any signs of damage be apparent (tubes broken, case dented, etc.), notify the store from which it was purchased. If the unit was shipped to you, also file a claim with the carrier.

The following accessories should be included in the carton:

- 1 Standard Phone Plug
- 1 Jumper Plug (for the auxiliary control socket)

INSTALLATION

POWER SOURCE

The receiver is designed to operate from a 90 — 125 volt, 50 — 60 cycle AC power source. **DO NOT OPERATE FROM A DC SOURCE.** The receiver is equipped with a voltage selector switch (located within the unit). This switch should normally be left in the 117V position.

SPEAKER CONNECTION

A three-terminal strip marked OUTPUT is provided at the rear of the receiver for speaker connections. Any PM speaker with either 4 or 8 ohm impedance can be used. Simply connect

one lead to the ground terminal "O" and the other lead to the terminal that corresponds to the speaker impedance. The output power of the receiver is sufficient to drive a 4 — 12 inch PM speaker adequately.

HEADPHONES

A standard phone jack is provided on the front panel of the receiver for headphone reception. Low impedance (8 — 16 ohms) headphones are recommended for optimum results. Insertion of a phone plug into the jack automatically disconnects any speaker attached to the 8 ohm output terminal.

ANTENNAS

The terminals marked "A1", "A2", and "E" at the rear of the receiver are for antenna and ground connections. Either of the following two types of connections can be used to obtain satisfactory results.

INVERTED L ANTENNA

The inverted L type of antenna will provide satisfactory performance over the entire tuning range. Simply short A2 and E with a jumper wire, and connect one end of the antenna wire to A1. For good reception, the antenna wire should be placed as high as possible and 50 — 100 feet long (see Fig. 1). In some instances, a wire connected from terminal "E" to a water pipe may improve reception.

DOUBLET ANTENNA

A doublet antenna will give excellent results, especially on amateur bands. A 75 ohms balanced transmission line should be used (as shown in Fig. 2). Since the doublet antenna provides optimum performance only at a given frequency, it should be cut to the length for the most often used band of frequencies. The overall length of a doublet antenna can be determined by using the following formula:

$$L \text{ (Length in feet)} = \frac{468}{\text{Frequency in megacycles}}$$

properties broadside to its length, it should be oriented in such a manner that maximum signal pickup can be realized.

When using either a balanced transmission line or a twisted pair, the leads connect to terminals "A1" and "A2" respectively, and the jumper wire between "A2" and "E" is removed. A height of 30 — 50 feet is recommended for good reception of weak signals.

FUSE

A 2 amp fuse is located at the rear of the receiver. To remove it, unscrew the spring loaded cap. Replace only with one of a similar rating.

AUXILIARY CONTROL

A socket in the back of the receiver allows simultaneous control of this receiver with a transmitter. An external switching device can be constructed so that the receiver will be inoperative during periods of transmission. In this case, the FUNCTION switch is placed in the

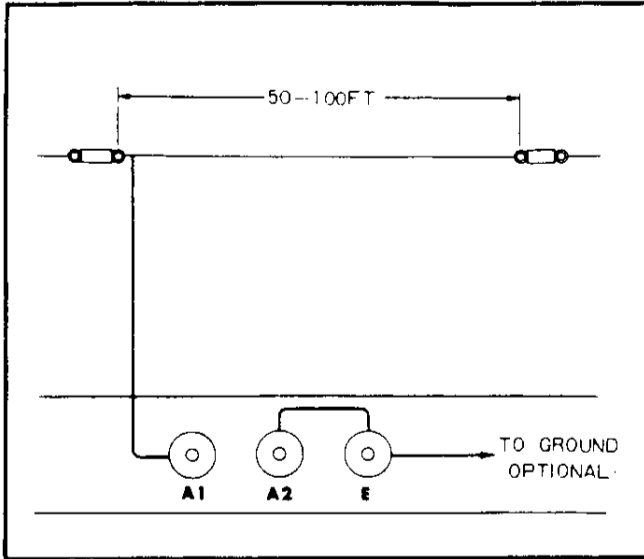

Figure 1. Single Wire Antenna (Inverted L)

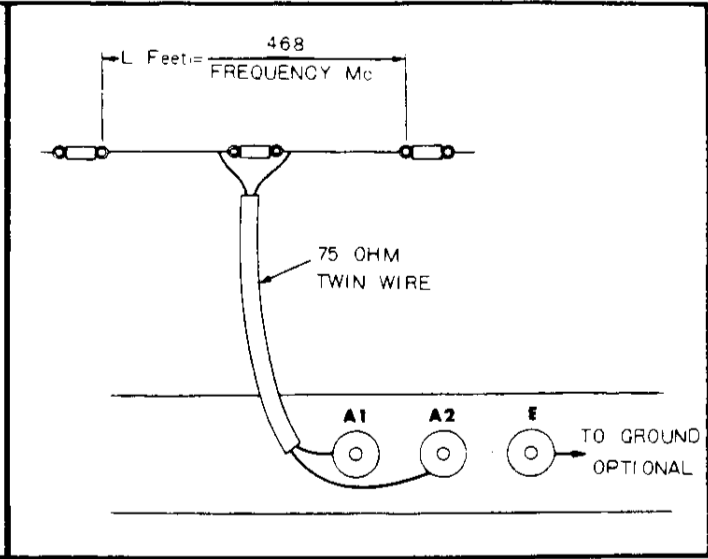

Figure 2. Doublet Antenna

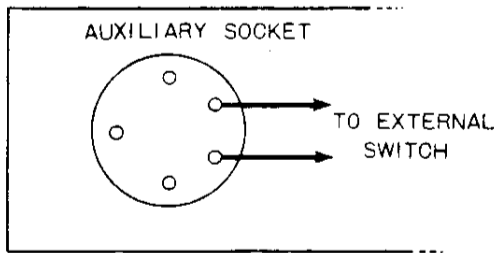

Figure 3. Auxiliary Control Socket

SEND position. The external switch is attached to the 5-pin plug so that pins 3 and 2 (see Fig. 3) will be connected when signal reception is de-

sired. This plug is then inserted into the socket in place of the jumper plug. In this manner, signal reception will be instantaneous, as plate voltage will be applied to the RF stages when the switch is closed accordingly.

For normal operating conditions with no external switching, the jumper plug provided must be inserted into the socket. Pins 3 and 2 of the plug are shorted, thus providing plate voltage to the RF stages. To disable the receiver under these conditions, set the FUNCTION switch to the SEND position. In this position plate voltages to the RF stages are cut off. Returning the switch to REC AM will provide instantaneous signal reception.

THE Q-MULTIPLIER CIRCUIT

A Q-Multiplier provides the additional selectivity often required for optimum reception of signals in the congested short-wave bands. In your receiver, the Q-Multiplier circuit serves a dual function — Q-Multiplier and BFO. For CW and SSB reception, the circuit is employed as a BFO.

THE CIRCUIT MAY BE EMPLOYED AS A Q-MULTIPLIER ONLY DURING PHONE RECEPTION.

A little experience in using the Q-Multiplier will be necessary for optimum results under different receiving conditions. In the hands of an experienced operator, the Q-Multiplier is a very handy tool, and will greatly enhance the performance of the receiver.

The controls associated with the Q-Multiplier

circuit are the SELECTIVITY and BFO-Q-MULT FREQUENCY controls. They are not operative unless the Function switch is in the Q-MULT position.

SELECTIVITY CONTROL

When the SELECTIVITY control is in the AM-CW-SSB position, the circuit oscillates, thus providing the beat signal necessary for CW or SSB reception. Off the AM-CW-SSB position, the circuit is connected to the IF stage and now acts as a narrow gate through which the IF signals must pass. The width of the "gate" is determined by the position of the SELECTIVITY control. Advancing the control from the fully counter-clockwise position serves to peak the signal increasingly until a point of oscillation is

reached. Sharpest selectivity is reached just prior to oscillation.

BFO-Q-MULT FREQUENCY CONTROL

The action of this control is determined by the position of the SELECTIVITY control. When the Selectivity control is set to AM-CW-SSB, the BFO-Q-MULT FREQUENCY control is used to apply pitch for CW reception or to provide clarity of signal for SSB reception.

When the Selectivity control is used to increase selectivity during Q-Multiplier operation, (as described previously), the sharp peak produced can be moved around within the IF pass band by means of the BFO-Q-MULT FREQUENCY CONTROL to reduce or eliminate interference from adjacent signals.

USING THE CIRCUIT AS A Q-MULTIPLIER

Initially, all controls on the receiver should be

set to the positions indicated in the chart for AM settings. Tune in desired station. Set SELECTIVITY to the fully counter-clockwise position and FUNCTION to "Q-Mult". Increase AF gain if necessary. Advance the SELECTIVITY control until the desired degree of selectivity is obtained. The point of maximum selectivity is reached just before the circuit breaks into oscillation. The BFO-Q-MULT FREQUENCY control may now be adjusted to provide a reduction, or to eliminate, any adjacent channel interference.

USING THE CIRCUIT AS A BFO

Initially, all controls should be set as indicated in the chart for CW or SSB operation. Under these conditions the BFO-Q-MULT FREQUENCY control is used to vary the pitch (CW) or for clarity of signal (SSB). The SELECTIVITY control remains permanently in the AM-CW-SSB position for CW or SSB reception.

TUNING

The main tuning and bandspread dials are calibrated in megacycles and contain special markings to simplify tuning. The major amateur radio bands are contained in the 1.6 to 4.8, 4.8 to 14.5 and 10.3 to 30.00 megacycle bands. The location of each amateur band is indicated by heavy white scale lines on the main tuning dial. The circled letter or letters which appear with each band indicate the bandspread scale to be used. Calibration of the main tuning scales is correct when the bandspread pointer is set at 100 on the LOGGING SCALE.

Bandspreading on the amateur bands is carried out in the following manner: Set the bandspread pointer initially to 100 and the main tuning pointer directly over the circled letter for the band to be tuned. In some cases the band is split between two such letters. For example, B1 and B2 together cover the range of 7.0 to 7.35 megacycles — B1 from 7.0 to 7.17, B2 from 7.17 to 7.35 megacycles. The calibrated bandspread scale which is used is indicated to the right and left-hand side. Thus, if the main tuning pointer is set over B1, the bandspread scale in use is the one marked B1, the fourth one down. Tuning is then accomplished solely with the BANDSPREAD control.

Short-wave bandspreading, for other than amateur bands, is accomplished by setting the bandspread pointer at 100 on the Logging Scale and the main tuning pointer at the high end of the short-wave band to be tuned. Rotate the bandspread control to tune over the band. Mov-

ing the bandspread pointer towards O on the logging scale subtracts from the frequency indicated on the main tuning scale. Logging of short-wave stations is possible by noting the readings on both the Main Tuning and Logging Scales.

S - METER READINGS

The S-Meter provides a means of measuring the relative strength of incoming AM signals. Relative readings are only correct when the IF GAIN control is fully clockwise. Measurements are read in S units from 1 to 9 and in decibels above S9 from 0 to 40 db. The circuit is disabled when the MVC/AVC switch is in the MVC position.

A ZERO ADJ control at the rear of the receiver is provided for zeroing the S-Meter electrically. This adjustment is made with the antenna disconnected, IF GAIN control at maximum and AVC on.

ANTENNA TRIMMER

The ANT TRIM control, adjustable from the front panel, acts as a compensating capacitor to permit optimum matching of the receiver to the antenna at all frequencies. Initially, the control should be set to its mid-position (the dot on the front surface of the knob at 12 o'clock position). The control should always be adjusted for maxi-

imum background noise. Each setting will be good only over a limited range of frequencies. The trimmer should therefore always be readjusted after tuning to the general area where the expected signal is to be found.

AM OPERATION

For the reception of broadcast stations, short-wave listening, etc., place all controls in the positions indicated in the Initial Control Settings chart. Tune in station, using Main and Bandspread tuning controls as indicated in the section under "TUNING". Adjust ANT TRIM for highest "S" meter reading on signal. This antenna control setting is satisfactory while operating over a limited frequency range. If excessive spurious noises such as those caused by auto ignition make reception difficult, place the ANL OFF switch to the ON position. The automatic noise limiter should be used only when necessary, since it tends to reduce the overall efficiency of the receiver.

If interference from nearby stations makes reception difficult, the Q-Multiplier may be employed to minimize or eliminate the interference. Since the use of the Q-Multiplier results

in a narrower bandwidth it should only be employed when interference is severe and where maximum fidelity is not required.

CW OPERATION

The control settings required for the reception of code signals are indicated in the chart. AVC is switched off and the IF GAIN control is used as a volume control. Tune signal to zero beat. The BFO-Q-MULT FREQUENCY control should then be adjusted on either side of white dot for desired pitch.

SINGLE SIDE BAND OPERATION

The settings of controls for SSB reception is essentially the same as for CW (see chart). The BFO frequency however, is used in this case for carrier reinsertion. AVC is switched off and the IF GAIN control used to adjust the level. Tune station in with BANDSPREAD control and then adjust BFO-Q-MULT FREQUENCY control for clarity of speech. Slight readjustment of the BANDSPREAD may be necessary to provide best audio quality.

INITIAL CONTROL SETTINGS

CONTROL	AM SETTINGS	CW SETTINGS	SSB SETTINGS
FUNCTION	REC AM	Q-MULT	Q-MULT
BAND SEL	Set for desired range	Set for desired range	Set for desired range
SELECTIVITY	AM-CW-SSB*	AM-CW-SSB	AM-CW-SSB
BFO-Q-MULT FREQUENCY	Mid-position	Mid-position	Mid-position
IF GAIN	Maximum	Adjust for desired audio level	Adjust for desired audio level
ANT TRIM	12 o'clock position	12 o'clock position	12 o'clock position
MVC-AVC	AVC	MVC	MVC
ANL OFF-ON	Optional	Optional	OFF
BANDSPREAD	Set to 100 on Logging Scale	Set to 100 on Logging Scale	Set to 100 on Logging Scale
AF GAIN	Adjust for desired audio level	2/3 to 3/4 clockwise	2/3 to 3/4 clockwise

* Setting the SELECTIVITY control to AM-CW-SSB with the FUNCTION switch in REC AM disconnects the Q-Multiplier from the IF, allowing normal IF band pass.

LOCATION AND FUNCTION OF CONTROLS

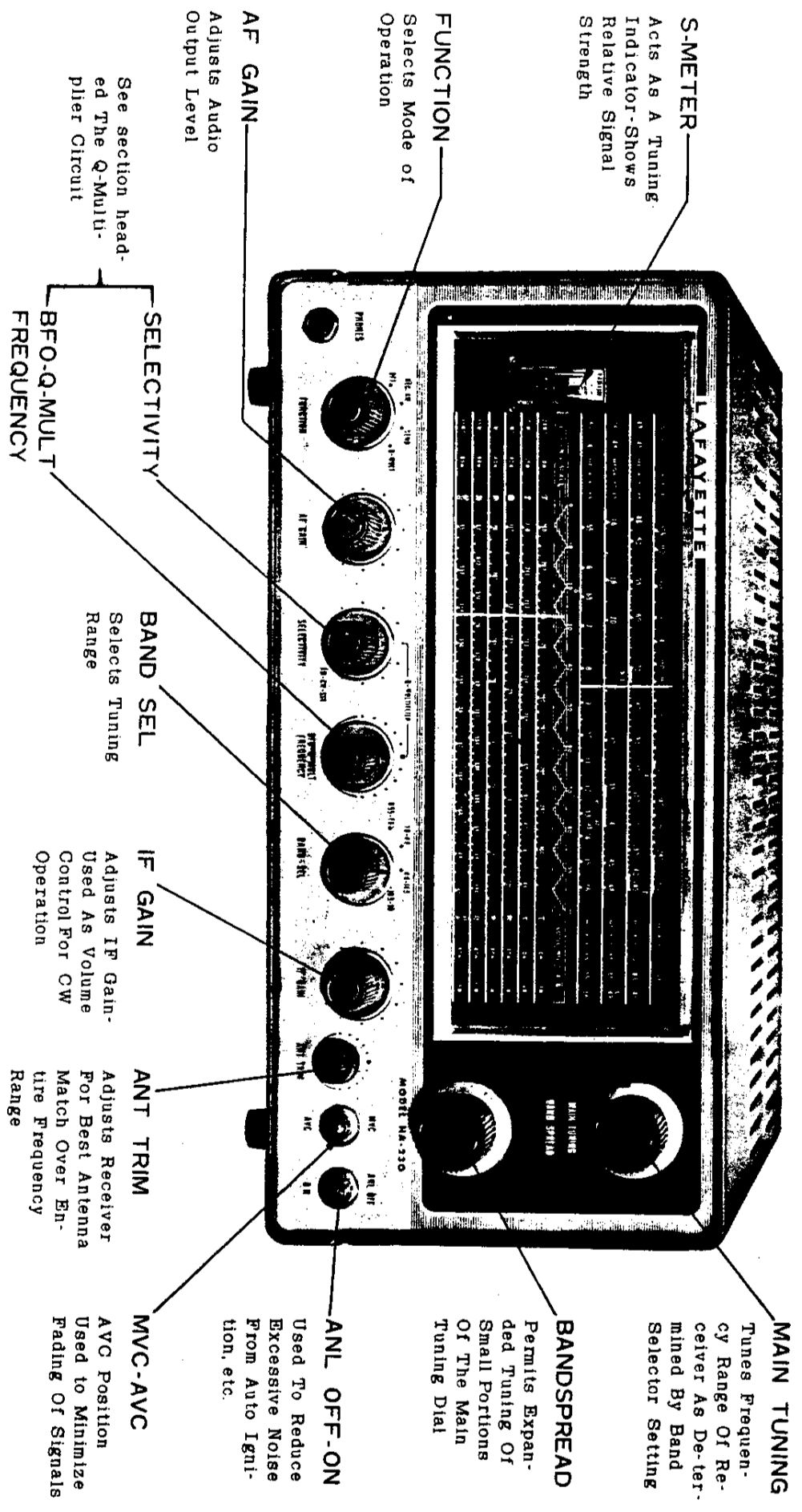

SHORT WAVE LISTENING

On the short-wave frequencies are to be found radio stations transmitting from all over the world. Many of these stations provide English-language broadcasts. The frequencies on which the majority of shortwave broadcast stations operate are found in the two upper bands of your receiver (4.8 to 14.5 megacycles and 10.5 to 30 megacycles). A characteristic of short-wave is that reception varies with the time of day, the season of the year and with weather condi-

tions. In order to know just when and where to listen, a listening chart which lists English language broadcast stations best heard in North America is included in this manual. "Better Shortwave Reception" by William I. Orr (available from Lafayette Radio as BK1032) is recommended to the short-wave listener and amateur alike. It provides an introduction to short-wave radio for the beginner and presents some of the practical aspects and helpful advice for the more experienced listener.

CIRCUIT THEORY

ANTENNA STAGE

The RF amplifier V1 provides the necessary gain and preselection required for high sensitivity and rejection of image frequencies. Individual antenna input coils are used for either a balanced or unbalanced input (depending on method of antenna connection).

The ANT TRIM control, adjustable from the front panel, acts as a compensating capacitor to permit matching of the input circuits to any antenna.

MIXER STAGE

The use of a separate high-frequency oscillator, V3, results in a more stable receiver, particularly at the higher frequencies. The output signal from V1 is electronically mixed with the output of V3 in the mixer tube V2. V3 provides a signal 455 KC higher than the incoming signal on all frequency ranges. Because current is applied to the filaments of V2 and V3 at all times (even with receiver switched off), no frequency drift is experienced at any time during the operation of this receiver — a high degree of stability is assured from the moment the unit is switched on.

Q-MULTIPLIER AND BFO

The Q-Multiplier circuit (V4) serves as both BFO and Q-Multiplier in this receiver. Used as a BFO for CW and SSB operation, the circuit, which acts as an oscillator, is coupled to the IF stage (via stray coupling) and provides the signal necessary for producing a beat note, or for carrier reinsertion during SSB operation. When the SELECTIVITY control, comprising R26 and S4, is in the AM-CW-SSB position during this operation, R26 is in its maximum position. The frequency of the signal is varied by means of C31, the BFO-Q-MULT FREQUENCY control. This adjusts the pitch during CW operation or clarity of speech during SSB operation. For Q-Multiplier

operation, S4 is switched away from the AM-CW-SSB position, thus connecting the circuit directly to the IF stage through a coupling capacitor C9. The circuit serves as a positive feedback device having a highly selective tuned circuit which acts as a narrow "gate" for IF frequencies. The width of this gate is adjusted by means of R26 which controls the gain of V4. The resultant narrow peak can be moved around in the IF pass-band by adjustment of C31. The selectivity thus becomes adjustable and, in addition, the portion of the signal which contains the least amount of adjacent signal interference can be selected.

IF STAGES

Two stages of IF amplification, V5 and V6, provide sufficient gain and selectivity for good performance. For maximum selectivity, double-tuned transformers, T2, T3 and T4, are used for interstage coupling. High-Q permeability-tuned transformers improve performance and add to ease of tuning. R24 varies the gain of V6 and therefore acts as the IF GAIN control.

The S-meter is placed in the circuit in such a manner that readings increase with signal strength. R28, the ZERO ADJ control, is adjusted for zero current through the meter with no signal input. The S-meter is only accurate when the IF gain control is at maximum, nor does the meter function properly when AVC is off.

DETECTOR, AVC, ANL, 1st AUDIO

One diode of V7 (pin 5) serves as both detector and AVC rectifier. The rectified AVC voltage is applied to RF stage V1 and IF stage V5 to keep the output level of the receiver constant regardless of input signal variations. In the MVC position of S6, the AVC is grounded and is not in operation. The other diode (pin 6) acts as an automatic noise limiter by cutting noise peaks (caused by auto ignition, etc.) during reception.

Listen to the Voices of the World

ENGLISH LANGUAGE SHORT-WAVE BROADCAST STATIONS BEST HEARD IN WESTERN NORTH AMERICA

Readers in the western part of the United States and Canada will find the following list of "Best Heard" stations helpful in tuning the short-wave broadcast bands. The left-hand column lists the hour in Pacific Standard Time for broadcasts in English only; in the middle column, the city and country from which the broadcasts originate are listed with the name the station uses for identification in parentheses; and on the right are the frequencies and call letters for stations using them during their broadcasts.

FREQUENCIES (kc.)

TIME (PST)	CITY, COUNTRY (NAME)	FREQUENCIES (kc.)
4:00-6:00 a.m.	Manila, Philippines (<i>The Call of the Orient</i>)	11855, 9730
6:30-7:30 a.m.	Djakarta, Indonesia (<i>The Voice of Indonesia</i>)	9710, 4910
7:15-8:15 a.m.	Melbourne, Australia (<i>Radio Australia</i>)	11770 (VLC11)
8:00-8:15 a.m.	Stockholm, Sweden (<i>Radio Sweden</i>)	15155
10:00-1:00 p.m.	London, England (<i>North American Service</i>)	17700, 15310
1:00-2:15 p.m.	London, England (<i>General Overseas Service</i>)	15310, 11930
2:15-3:15 p.m.	London, England (<i>General Overseas Service</i>)	17625 (JOA22), 15235 (JOBS)
3:00-3:30 p.m.	Tokyo, Japan (<i>Radio Japan</i>)	11930, 9825
3:00-7:00 p.m.	London, England (<i>General Overseas Service</i>)	17865, 15140
3:00-10:00 p.m.	Moscow, USSR (<i>Radio Moscow</i>)	15235 (JOB89), 11705 (JOA4)
4:30-4:50 p.m.	Tokyo, Japan (<i>Radio Japan</i>)	15190 (CKCX), 11720 (CHOL)
4:55-5:45 p.m.	Montreal, Canada (<i>Radio Canada</i>)	15400, 9656
5:00-7:30 p.m.	Cape Haitien, Haiti (<i>The Evangelistic Voice</i>) - no broadcast on Wednesday and Thursday	11965 (HER5), 9535 (HERA)
5:30-7:15 p.m.	Berne, Switzerland (<i>Switzerland Calling</i>)	6165 (HER3)
6:00-9:00 p.m.	Quito, Ecuador (HCJB - <i>The Voice of the Andes</i>) - no broadcast on Monday	15115, 11915, 9745
6:25-6:45 p.m.	Rome, Italy (<i>Italian Broadcasting & TV System</i>)	9575, 6010
6:30-6:40 p.m.	Cologne, Germany (<i>The Voice of Germany</i>)	17795, 9640
6:30-7:00 p.m.	Warsaw, Poland (<i>Radio Warsaw</i>)	9525, 6025
6:30-7:10 p.m.	Hilversum, Holland (<i>Radio Netherlands</i>)	11950, 9590
6:30-8:00 p.m.	Hilversum, Holland (<i>The Happy Station</i>) - special program on Sundays only	11950, 9590
6:45-7:00 p.m.	Brazzaville, FEA (<i>Radio Brazzaville, French Equatorial Africa</i>)	11970, 9825
6:55-7:35 p.m.	Montreal, Canada (<i>Radio Canada</i>)	11945 (CKNK), 9585 (CKLP)
7:00-7:30 p.m.	Bucharest, Romania (<i>Bucharest Calling</i>)	11937, 9570
7:00-7:30 p.m.	Peking, China (<i>Radio Peking</i>)	17745, 17720, 15350, 15118
7:00-8:30 p.m.	Prague, Czechoslovakia (<i>Radio Prague</i>)	9585, 6170, 6105, 6055
7:00-8:45 p.m.	Guatemala City, Guatemala (TGNA)	9668, 5952
7:15-8:00 p.m.	Madrid, Spain (<i>The Voice of Spain</i>)	9360, 6130
7:30-8:00 p.m.	Copenhagen, Denmark (<i>The Voice of Denmark</i>) - no English on Sundays	9520 (OZF), 15235 (JOB89), 11705 (JOA4)
7:30-8:00 p.m.	Tokyo, Japan (<i>Radio Japan</i>)	15175, 11735, 9540
8:00-8:20 p.m.	Oslo, Norway (<i>Radio Norway</i>) - on Sundays only	11705 (JOA4)
8:00-8:30 p.m.	Budapest, Hungary (<i>Radio Budapest</i>)	19170, 9833
8:00-8:30 p.m.	Sofia, Bulgaria (<i>Sofia Calling</i>)	9700
8:00-9:00 p.m.	San Jose, Costa Rica (TIFC - <i>The Lighthouse of the Caribbean</i>)	9647, 6037
8:15-9:00 p.m.	Berne, Switzerland (<i>Switzerland Calling</i>)	11865 (HER5), 9535 (HER4)
8:15-9:00 p.m.	Madrid, Spain (<i>The Voice of Spain</i>)	9360, 6130
8:30-9:00 p.m.	Bucharest, Romania (<i>Bucharest Calling</i>)	11937, 9570
9:00-9:30 p.m.	Taipei, Taiwan (<i>The Voice of Free China</i>)	15225, 11815
9:00-9:30 p.m.	Stockholm, Sweden (<i>Radio Sweden</i>)	9520
9:15-9:30 p.m.	Brazzaville, FEA (<i>Radio Brazzaville, French Equatorial Africa</i>)	11970
9:15-10:00 p.m.	Madrid, Spain (<i>The Voice of Spain</i>)	9360, 6130
9:30-10:00 p.m.	Warsaw, Poland (<i>Radio Warsaw</i>)	9525, 6025
10:30-11:00 p.m.	Taipei, Taiwan (<i>The Voice of Free China</i>)	15225, 11815

REPRINTED FROM POPULAR ELECTRONICS BY PERMISSION

TIME (PST)	CITY, COUNTRY (NAME)	FREQUENCIES (kc.)
10:30-2:45 a.m.	Wellington, New Zealand (<i>Radio New Zealand</i>)	9540 (ZL2), 6090 (ZL7)
11:30-11:45 p.m.	Papeete, Tahiti (<i>The Voice of France in the Pacific</i>)	6135
12:00-1:15 a.m.	Manila, Philippines (<i>Call of the Orient</i>)	17805, 15300, 11855, 9730

NEWS BROADCASTS FOR WESTERN NORTH AMERICA

The following listing of news broadcasts has been prepared for those readers living in the Western United States and Canada. Times are given in Pacific Standard Time and the frequencies in kilocycles.

TIME (PST)	CITY AND COUNTRY	FREQUENCIES (kc.)
6:45 a.m.	Djakarta, Indonesia	9710, 4910
7:00 a.m.	Manila, Philippines	11855, 9730
7:30 a.m.	Melbourne, Australia	11770
8:00 a.m.	Stockholm, Sweden	15155
9:00 a.m.	London, England	17700
12:00 Noon	London, England	17700
3:00 p.m.	Tokyo, Japan	15310, 11930, 9825
3:00 p.m.	Moscow, USSR	17825, 15235
4:00 p.m.	Moscow, USSR	17865, 15140
4:30 p.m.	Deli, India	17720, 15160
4:30 p.m.	Tokyo, Japan	15235, 11705
5:00 p.m.	Montreal, Canada	15190, 11720
5:00 p.m.	Moscow, USSR	17865, 15140
5:00 p.m.	Karachi, Pakistan	17750, 15335
5:30 p.m.	Montreal, Canada	15190, 11720
5:35 p.m.	Berne, Switzerland	11865, 9535, 6165
6:00 p.m.	London, England	11930, 9825
6:00 p.m.	Moscow, USSR	17865, 15140
6:25 p.m.	Rome, Italy	9575, 6010
6:30 p.m.	Cologne, Germany	11795, 9640
6:30 p.m.	Warsaw, Poland	9525, 6025
6:30 p.m.	Hilversum, Holland (not on Sunday)	11950, 9590
6:30 p.m.	Deli, India	17830, 15140, 11710
6:45 p.m.	Brazzaville, French Equatorial Africa	11970, 9825
7:00 p.m.	Moscow, USSR	17865, 15140
7:00 p.m.	Montreal, Canada	11945, 9585
7:00 p.m.	Bucharest, Romania	11937, 9570
7:00 p.m.	Peking, China	17745, 17720, 15350, 15118
7:00 p.m.	Prague, Czechoslovakia	9585, 6170, 6105, 6055
7:15 p.m.	Madrid, Spain	9360, 6130
7:30 p.m.	Copenhagen, Denmark (only Mondays)	9520
7:30 p.m.	Tokyo, Japan	15235, 11705
8:00 p.m.	Moscow, USSR	17865, 15140
8:00 p.m.	Oslo, Norway (only Sundays)	15175, 11735, 9540
8:00 p.m.	Sofia, Bulgaria	9700
8:15 p.m.	Madrid, Spain	9360, 6130
8:20 p.m.	Berne, Switzerland	11865, 9535
8:30 p.m.	Bucharest, Romania	11937, 9570
8:30 p.m.	Taipei, Taiwan	15225, 11815
8:30 p.m.	Moscow, USSR	17865, 15140
8:30 p.m.	Stockholm, Sweden	9520
8:30 p.m.	Brazzaville, French Equatorial Africa	11970
8:30 p.m.	Madrid, Spain	9360, 6130
8:30 p.m.	Warsaw, Poland	9525, 6025
9:00 p.m.	Taipei, Taiwan	15225, 11815
9:00 p.m.	Wellington, New Zealand	9540, 6090
9:15 p.m.	Papeete, Tahiti	6135
9:30 p.m.	Wellington, New Zealand (not on Sunday)	9540, 6090
9:30 p.m.	Manila, Philippines	1855, 9730
9:30 p.m.	Wellington, New Zealand	9540, 6090

ENGLISH LANGUAGE SHORT-WAVE BROADCAST STATIONS BEST HEARD IN EASTERN NORTH AMERICA

TIME (EST)	CITY, COUNTRY (NAME)	FREQUENCIES (kc)
6:00-6:30 a.m.	Warsaw, Poland (Radio Warsaw)	17000, 15120
7:00-7:15 a.m.	Helsinki, Finland (Finland Calling) - no English on Sundays and holidays	17798, 15190
7:15-8:15 a.m.	Warsaw, Poland (Radio Warsaw)	17800, 15120
8:00-9:30 a.m.	Melbourne, Australia (Radio Australica)	11770, (VLA11)
	Cape Haitien, Haiti (The Evangelistic Voice) - no broadcast on Thursdays	15380, 9638
8:15-8:45 a.m.	Stockholm, Sweden (Radio Sweden)	17840
10:00-12:15 p.m.	London, England (North American Service)	17700
1:00-4:00 p.m.	London, England (North American Service)	17700
4:00-5:15 p.m.	London, England (General Overseas Service)	17700
4:15-4:45 p.m.	Hilversum, Holland (Radio Netherlands) - no English on Sundays	17700, 15310, 9008
4:30-5:20 p.m.	Jerusalem, Israel (The Voice of Zion)	15365, 11950
5:00-5:30 p.m.	Port-au-Prince, Haiti (Radio Commerce)-on Sundays only	9008
5:15-6:15 p.m.	London, England (General Overseas Service)	9482 (4VC)
6:00-6:30 p.m.	Tokyo, Japan (Radio Japan)	15310, 11930
6:00-10:00 p.m.	London, England (General Overseas Service)	17825 (JOA22), 15235 (JOB9)
6:00-1:00 a.m.	Moscow, USSR (Radio Moscow)	11930, 9825
		11937, 11890, 11845
		11825, 11805, 11740, 11700, 9700, 9665
		9615
4:15-7:00 p.m.	Ankara, Turkey (Radio Ankara)	9575, 6010
7:15-7:35 p.m.	Rome, Italy (Italian Broadcasting and Television System)	15235 (JOB9), 11705 (JOA4)
7:30-7:50 p.m.	Tokyo, Japan (Radio Japan)	11910, 9833
7:30-8:00 p.m.	Budapest, Hungary (Radio Budapest)	9585, 6170, 6105, 6055
7:30-8:00 p.m.	Prague, Czechoslovakia (Radio Prague)	9525, 6025
7:30-8:30 p.m.	Warsaw, Poland (Radio Warsaw)	15190 (CKCX), 11720
7:55-8:45 p.m.	Montreal, Canada (Radio Canada)	9700
8:00-8:30 p.m.	Sofia, Bulgaria (Sofia Calling)	9620
8:00-9:30 p.m.	Stockholm, Sweden (Radio Sweden)	15400, 9555, 6105
8:00-10:30 p.m.	Cape Haitien, Haiti (The Evangelistic Voice) - no broadcasts on Wednesdays and Thursdays	11970, 9625
8:15-9:00 p.m.	Brazzaville, French Equatorial Africa (Radio Brazzaville)	11865 (HERS), 9535 (HER4), 6105 (HER3)
8:30-10:15 p.m.	Berne, Switzerland (Switzerland Calling)	15175, 11735, 9540
9:00-9:20 p.m.	Oslø, Norway (Radio Norway) - on Sundays only	9520 (VZF)
9:00-9:30 p.m.	Copenhagen, Denmark (The Voice of Denmark) - no English on Sundays	15115, 11915, 9745
9:00-12:00 p.m.	Quito, Ecuador (HCJB - The Voice of the Andes) - no broadcasts on Mondays	9575, 6010
9:25-9:45 p.m.	Rome, Italy (Italian Broadcasting and Television System)	11795, 9540
9:30-9:40 p.m.	Cologne, Germany (The Voice of Germany)	9525, 6025
9:30-10:00 p.m.	Warsaw, Poland (Radio Warsaw)	11950, 9590
9:30-10:10 p.m.	Hilversum, Holland (Radio Netherlands)	11950, 9590
9:30-11:00 p.m.	Hilversum, Holland (The Happy Station) - special program on Sundays only	11950, 9590
9:30-11:00 p.m.	Port-au-Prince, Haiti (Radio Haiti) - on Thursdays only	6192 (4VHW)
9:45-10:00 p.m.	Brazzaville, French Equatorial Africa (Radio Brazzaville)	11970, 9625
9:55-10:35 p.m.	Montreal, Canada (Radio Canada)	11945 (CKNK), 9585 (CKLP)
10:00-10:30 p.m.	Bucharest, Romania (Bucharest Calling)	11937, 9570
10:00-11:00 p.m.	Prague, Czechoslovakia (Radio Prague)	9585, 6170, 6105, 6055
10:00-11:45 p.m.	Guatemala City, Guatemala (TCNA)	9668, 5952
10:15-11:00 p.m.	Madrid, Spain (The Voice of Spain)	9560, 6130
10:30-11:00 p.m.	Copenhagen, Denmark (The Voice of Denmark) - no English on Sundays	9520 (VZF)
11:00-11:30 p.m.	Budapest, Hungary (Radio Budapest)	11910, 9833
11:00-11:30 p.m.	Sofia, Bulgaria (Sofia Calling)	9700
11:00-12:00 p.m.	San Jose, Costa Rica (TIFC - The Lighthouse of the Caribbean)	9647, 6037
11:15-12:00 p.m.	Berne, Switzerland (Switzerland Calling)	11865 (HERS), 9535 (HER4)
11:15-12:00 p.m.	Madrid, Spain (The Voice of Spain)	9360, 6130
11:30-12:00 p.m.	Bucharest, Romania (Bucharest Calling)	11937, 9570
12:00-12:30 a.m.	Stockholm, Sweden (Radio Sweden)	9620
12:15-12:30 a.m.	Brazzaville, French Equatorial Africa (Radio Brazzaville)	11970
12:15-1:00 a.m.	Madrid, Spain (The Voice of Spain)	9360, 6130
12:30-1:00 a.m.	Warsaw, Poland (Radio Warsaw)	9525, 6025

NEWS BROADCASTS FOR EASTERN NORTH AMERICA

CITY AND COUNTRY	TIME (EST)	FREQUENCIES (kc)
Wellington, New Zealand	5:30 a.m.	9540, 6080
Warsaw, Poland	6:00 a.m.	17800, 15120
Djarsarta, Indonesia	6:15 a.m.	9710
Helsinki, Finland	7:00 a.m.	17798, 15190
Warsaw, Poland	7:15 a.m.	17800, 15120
Melbourne, Australia	7:15 a.m.	11770
Warsaw, Poland	7:45 a.m.	17800, 15120
Stockholm, Sweden	8:15 a.m.	17840
Melbourne, Australia	8:15 a.m.	11770
Lisbon, Portugal	8:45 a.m.	21495, 17895
London, England	17700	
Lisbon, Portugal	21700, 17895	
Athens, Greece	17775, 15345	
London, England	17700	
Tehran, Iran	15100	
Damascus, Syria	17845	
Hilversum, Holland	15365, 11950	
Jerusalem, Israel	9008	
Belgrade, Yugoslavia	6100	
London, England	15310, 11930, 9825	
Tokyo, Japan	17825, 15235	
Moscow, USSR	11937, 11890, 11845, 11825, 11805, 11740, 11700, 9700, 9665	
Ankara, Turkey	9515	
Caracas, Venezuela (Monday-Friday)	4970	
Moscow, USSR	11937, 11890, 11845, 11825, 11805, 11740, 11700, 9700, 9665	
Rome, Italy	9575, 6010	
Tokyo, Japan	15235, 11705	
Prague, Czechoslovakia	9585, 6170, 6105, 6055	
Warsaw, Poland	9525, 6025	
Moscow, USSR	11890, 11845, 11825, 11805, 11740, 11700, 9665	
Montreal, Canada	15190, 11720	
Warsaw, Poland	9525, 6025	
Sofia, Bulgaria	9700	
Stockholm, Sweden	9620	
Brazzaville, French Equatorial Africa	11970, 9625	
Montreal, Canada	15190, 11720	
Paramaribo, Surinam (Mondays only)	15407, 4752	
Berne, Switzerland	11865, 9535, 6165	
Stockholm, Sweden	9620	
Oslø, Norway	15175, 11735, 9540	
(Sundays only)		
Copenhagen, Denmark (Mondays only)	9520	
Moscow, USSR	11890, 11845, 11825, 11805, 11740, 11700, 9700, 9665	
Rome, Italy	9575, 6010	
Cologne, Germany	11795, 9540	
Warsaw, Poland	9525, 6025	
Hilversum, Holland (not on Sundays)	11950, 9590	
Brazzaville, French Equatorial Africa	11970, 9625	
Montreal, Canada	11945, 9585	
Moscow, USSR	11890, 11845, 11825, 11805, 11740, 11700, 9665	
Bucharest, Romania	11937, 9570	
Madrid, Spain	9360, 6130	
Copenhagen, Denmark (Monday only)	9520	
Sofia, Bulgaria	9700	
Moscow, USSR	11890, 11845, 11825, 11805, 11740, 11700	
Madrid, Spain	9360, 6130	
Berne, Switzerland	11865, 9535	
Bucharest, Romania	11937, 9570	
Stockholm, Sweden	9620	
Moscow, USSR	11860, 11845, 11805, 11740, 11700, 9665, 9610	
Madrid, Spain	9360, 6130	
Brazzaville, French Equatorial Africa	11970	
Warsaw, Poland	9525, 6025	

RF V1 6BA6 MIXER V2 6BE6 Q MULTIPLIER-BFO V4 6AV6 IF₁ V5 6BA6 IF₂ V6 6BA6 DETECTOR, ANL, 1ST AUDIO V7 6AV6 AUDIO OUTPUT V8 6AQ5

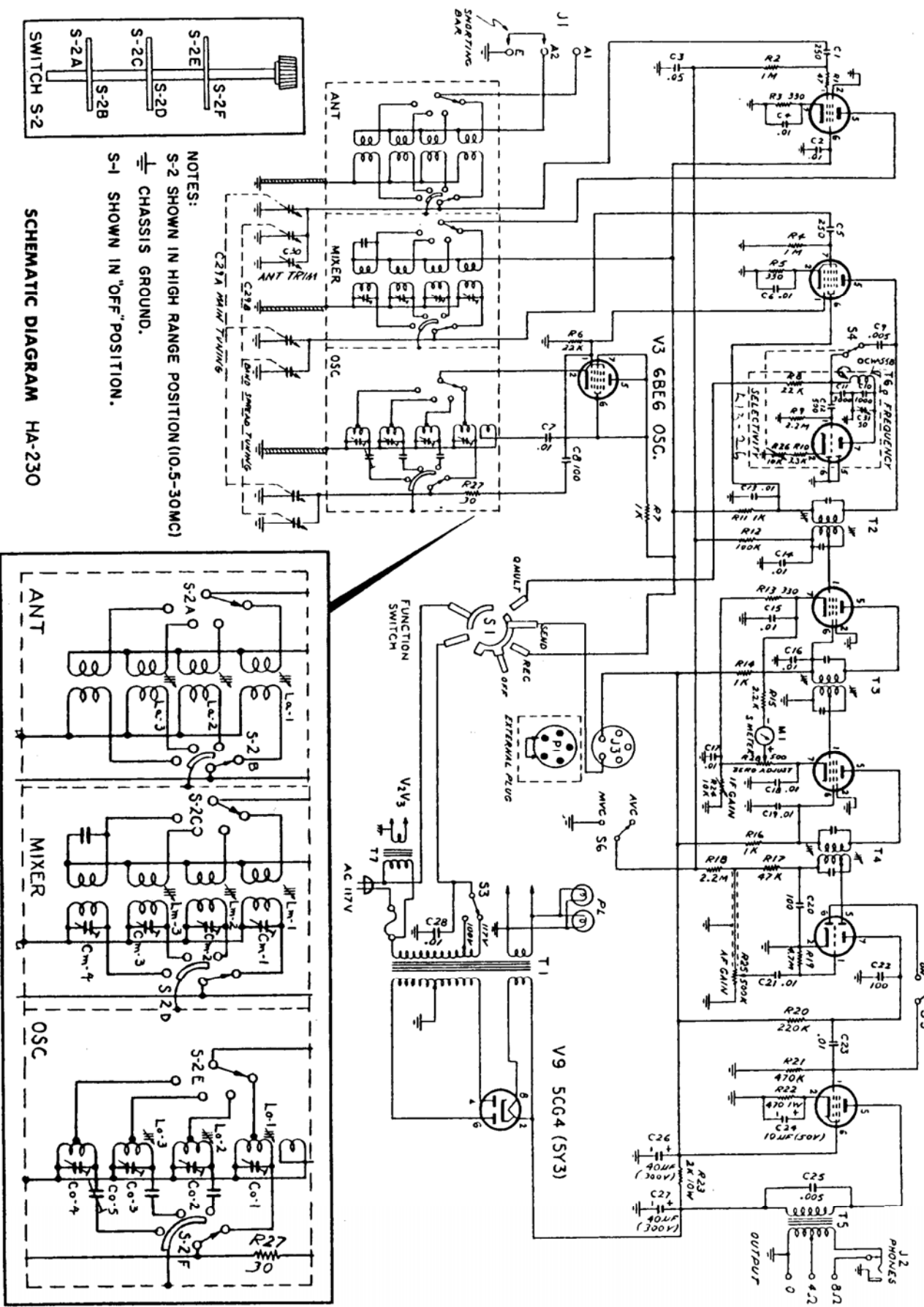

NOTES:
 S-2 SHOWN IN HIGH RANGE POSITION (10.5-30MC)
 CHASSIS GROUND.
 S-1 SHOWN IN "OFF" POSITION.

SCHEMATIC DIAGRAM HA-230

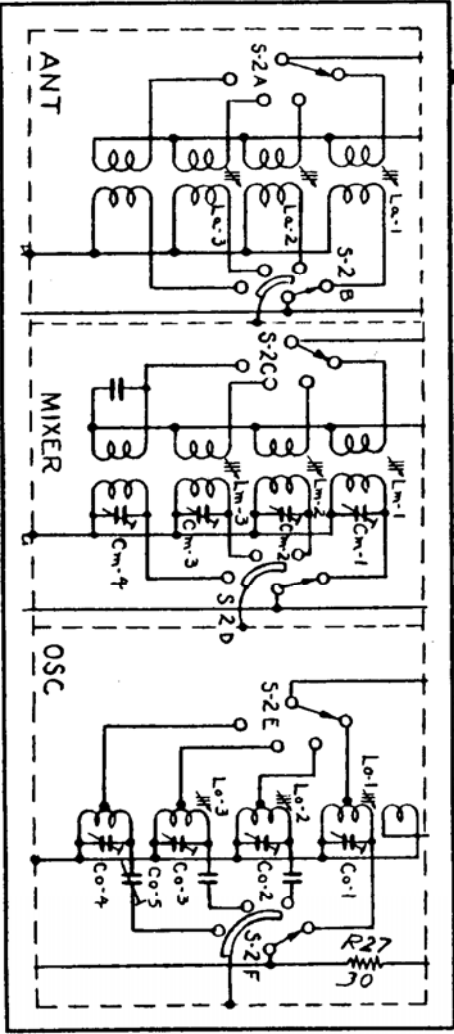
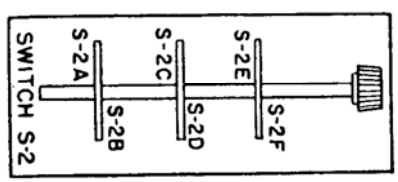

RF
V1 6BA6

MIXER
V2 6BE6

Q MULTIPLIER-BFO
V4 6AV6

IF1
V5 6BA6

V6

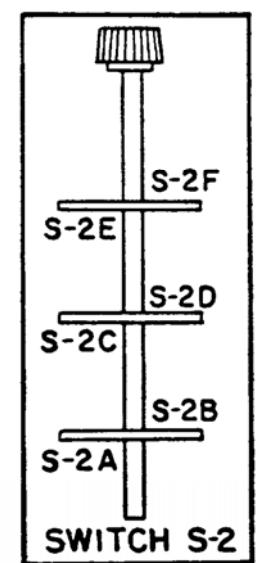
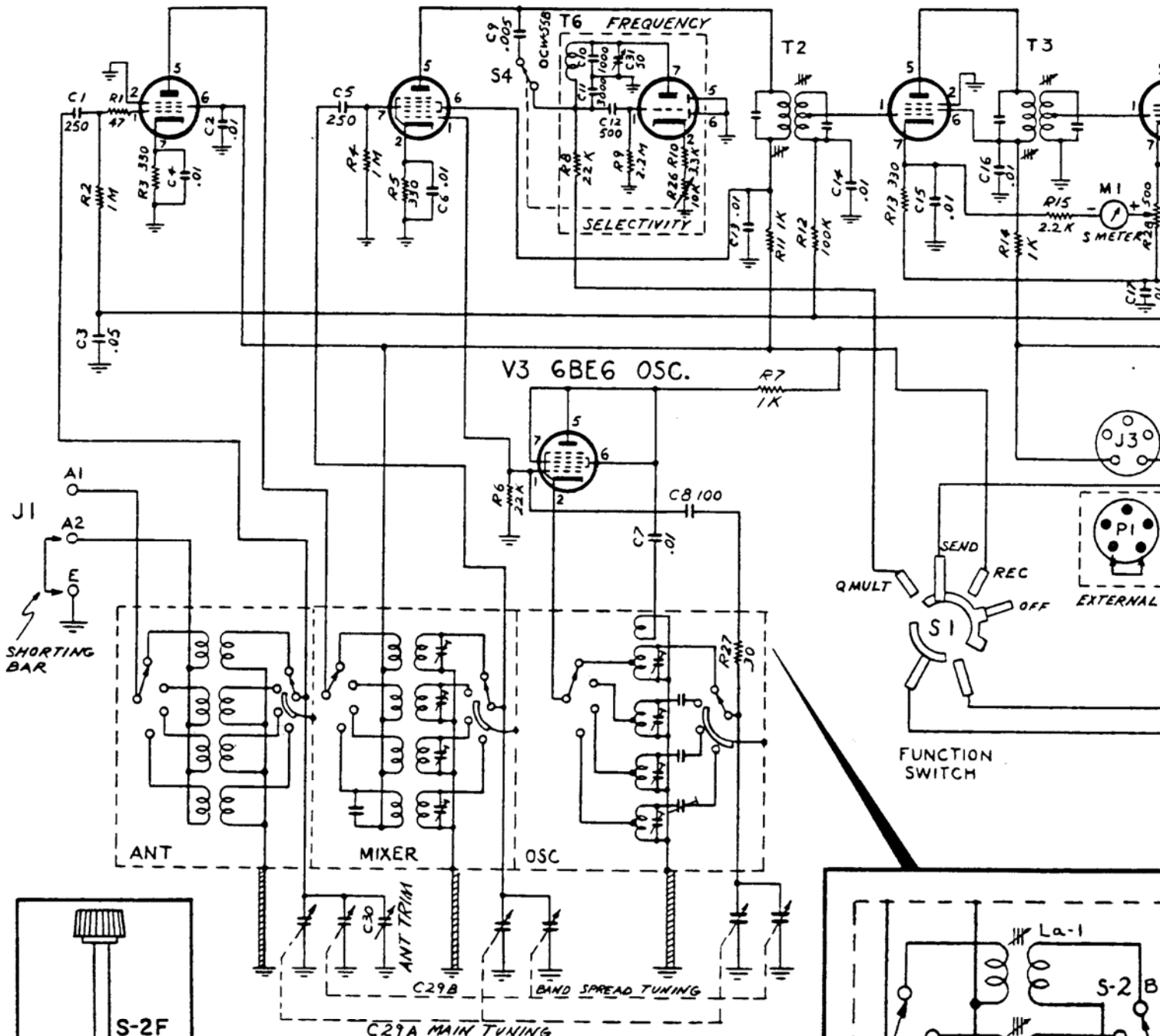

NOTES:
S-2 SHOWN IN HIGH RANGE POSITION (10.5-30MC)
⊥ CHASSIS GROUND.
S-1 SHOWN IN "OFF" POSITION.

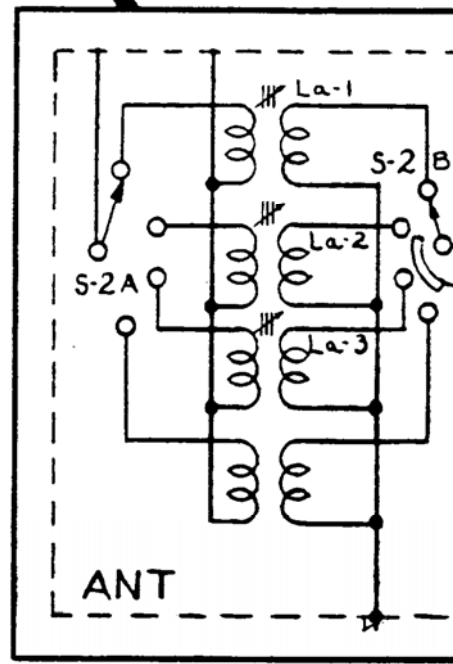

SCHEMATIC DIAGRAM HA-230

IF1
V5 6BA6

IF2
V6 6BA6

DETECTOR, ANL, 1ST AUDIO
V7 6AV6

AUDIO OUTPUT
V8 6AQ5

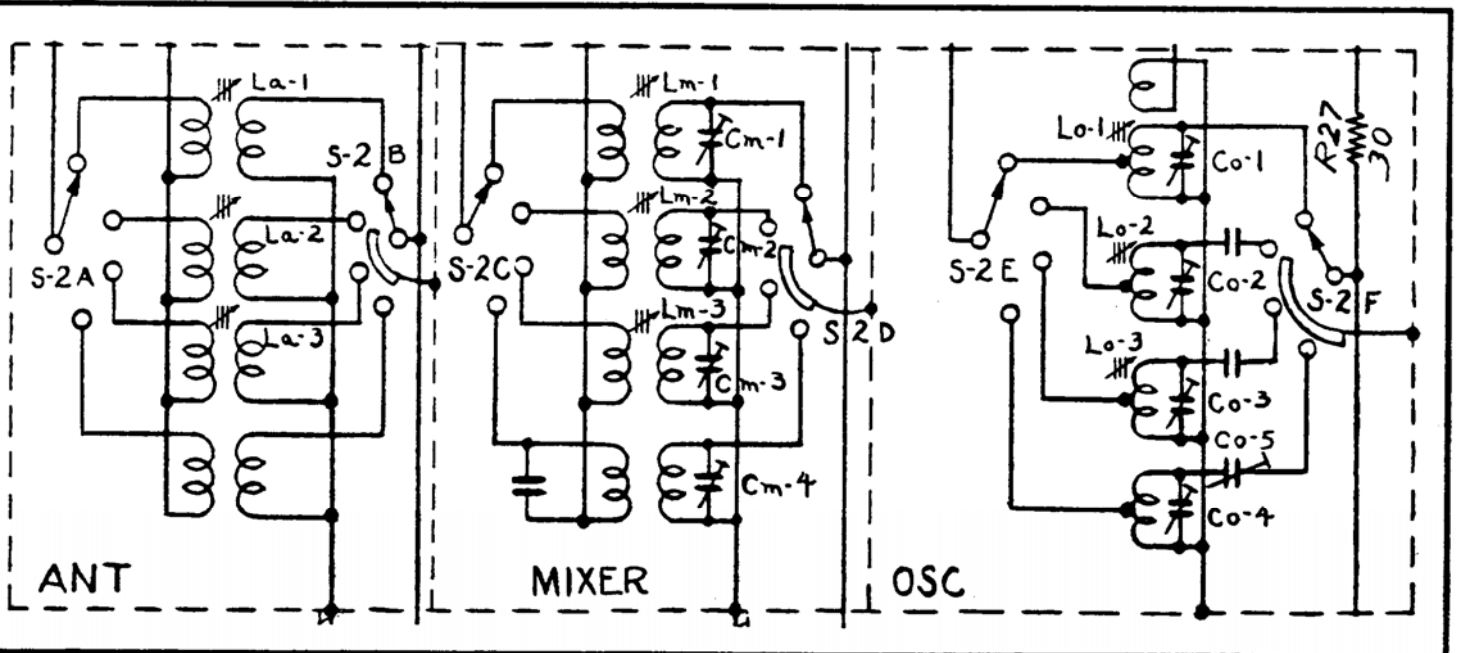
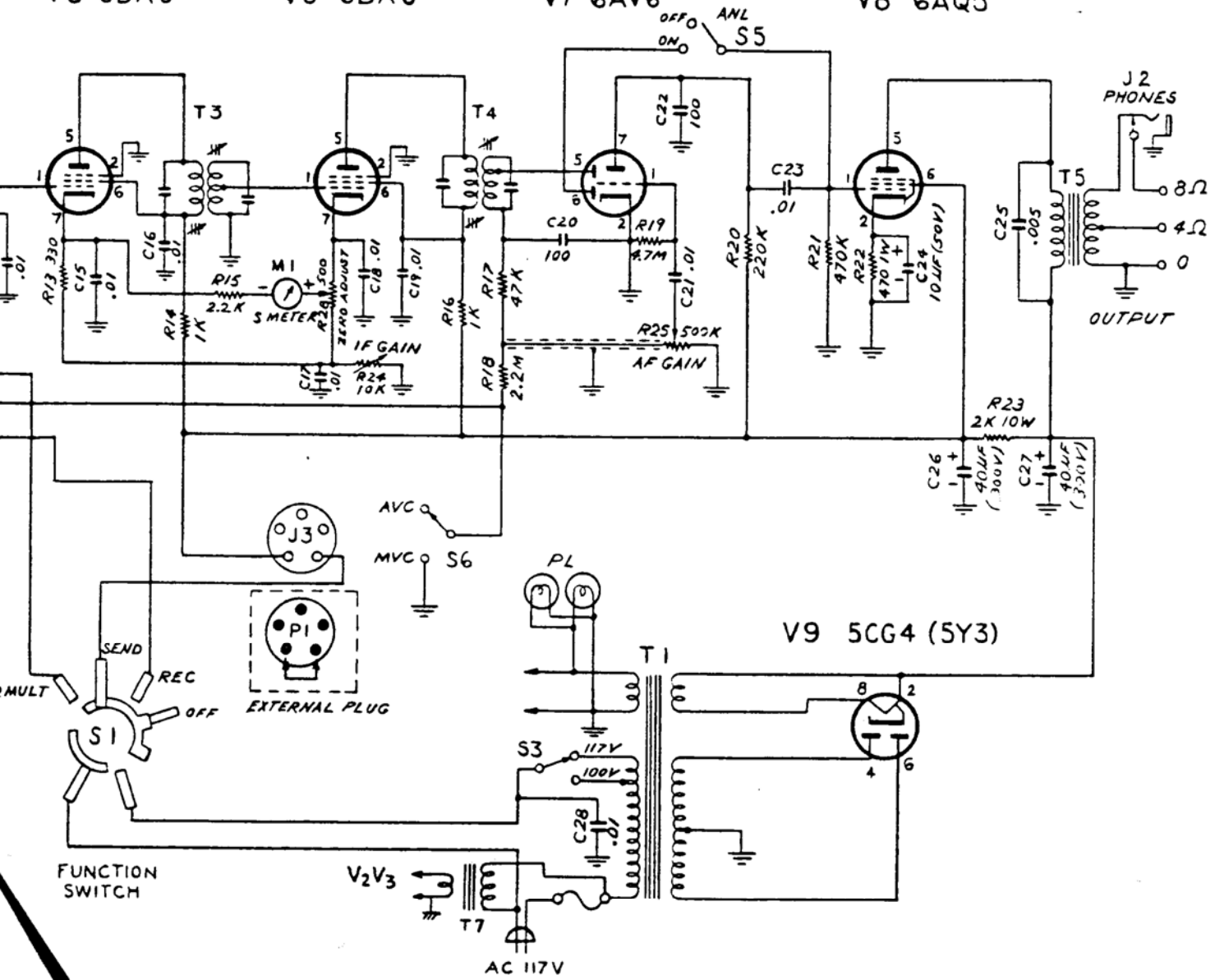

Since this causes a slight reduction in fidelity, the circuit should only be used when necessary.

The rectified signal from the detector is fed to the grid of the triode section of V7 which acts as the 1st audio amplifier. Audio level is adjusted by means of R25, the AF GAIN control.

AUDIO AMPLIFIER

V8 is employed in a conventional resistance-coupled audio amplifier which is connected to output transformer T5. Taps are provided on the secondary of the transformer for 4 or 8 ohm speakers. A standard phone jack, accessible from the front panel, permits the use of low impedance headphones when desired. Insertion of a plug in the jack automatically disconnects any speaker connected to the 8 ohm tap.

RECTIFIER

V9 functions as a full-wave rectifier in a conventional power supply circuit. C26, R23 and C27 provide the necessary filtering. The primary of the AC power transformer is fused for safety. The tapped primary also permits the use of the

receiver on low AC voltages (less than 100), voltage selection being effected by S3. In most cases however, the switch should be left in the 117V position.

A separate 6 volt filament transformer is employed for V2 (mixer) and V3 (oscillator). The AC power to the primary of this transformer is not switched and thus continuously supplies filament voltage to V2 and V3 even with the receiver switched off, maintaining these tubes at a proper operating temperature. This arrangement ensures stable, drift-free operation as soon as the receiver is turned on. The current drawn by these tubes is negligible.

FUNCTION SWITCH

This switch determines the mode of operation. In all positions except OFF, AC power is applied to the primary of T1, thus powering the receiver. In REC AM, DC plate voltage is applied (through the external jumper plug and the switch) to V1, V2 and V3. All other tubes (except V4) receive DC plate voltage direct from the power supply. In the SEND position, plate voltage to V1, V2 and V3 is cut off. In the Q-MULT position, plate voltage is also applied to V4, in addition to all other tubes.

SERVICE

This section contains information which will aid qualified service personnel in the servicing and alignment of your receiver.

CHASSIS REMOVAL

The top cover is held by four screws — two each side. The bottom cover is held by six screws on the underside of the unit.

IF ALIGNMENT

EQUIPMENT REQUIRED:

AC Voltmeter
Calibrated RF Signal Generator
Non-Metallic Alignment Tool (GC No. 8722 or equiv.)

1. Connect a loudspeaker to the output terminals. Remove the local oscillator V3, 6BE6, from its socket.
2. Set the receiver controls as follows:
FUNCTION switch on REC AM
AF GAIN control to maximum
SELECTIVITY control on AM-CW-SSB
IF GAIN control 3/4 full position
MVC - AVC switch on MVC
ANL off
3. Connect the voltmeter (3 volt AC range) across the speaker terminals.
4. Connect the signal generator between pin 7 of V2 socket (6BE6 mixer tube) and ground.
5. Set the signal generator at 455KC and modulate it with either 400 or 1000 cycles (30%).
6. Adjust the secondary and primary of IF transformers T4, T3 and T2 (see Fig. A). Follow the order given — secondary first, then primary in each case. Topside adjustments are secondaries, bottom of chassis adjustments are primaries. During alignment, lower the generator output progressively to prevent overloading. Repeat alignment until no further improvement is noted.

BFO AND Q-MULTIPLIER ADJUSTMENT

1. All receiver controls should be set as in the IF alignment with the exception of the following:
 FUNCTION switch to Q-MULT
 BFO-Q-MULT FREQUENCY to mid-position (white dot)
 Reduce AF GAIN

2. Set the generator to 455KC, unmodulated RF.
3. Adjust the BFO coil T6 (located next to V4, Q-MULT) until a zero beat is heard (also accompanied by a minimum reading on the voltmeter. Note that the minimum point will be bracketed by a peak on each side).

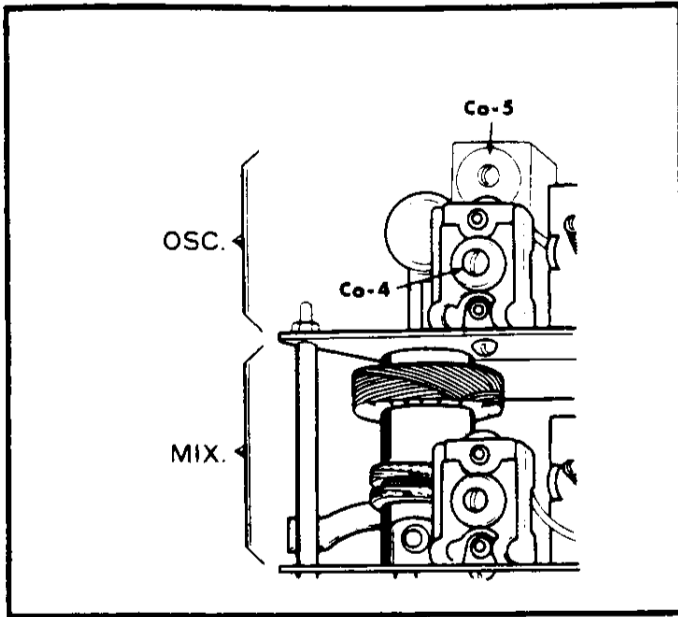

THESE TWO ADJUSTMENTS MADE WITH BOTTOM COVER REMOVED-REMAINDER OF RF ALIGNMENT CARRIED OUT WITH COVER IN PLACE

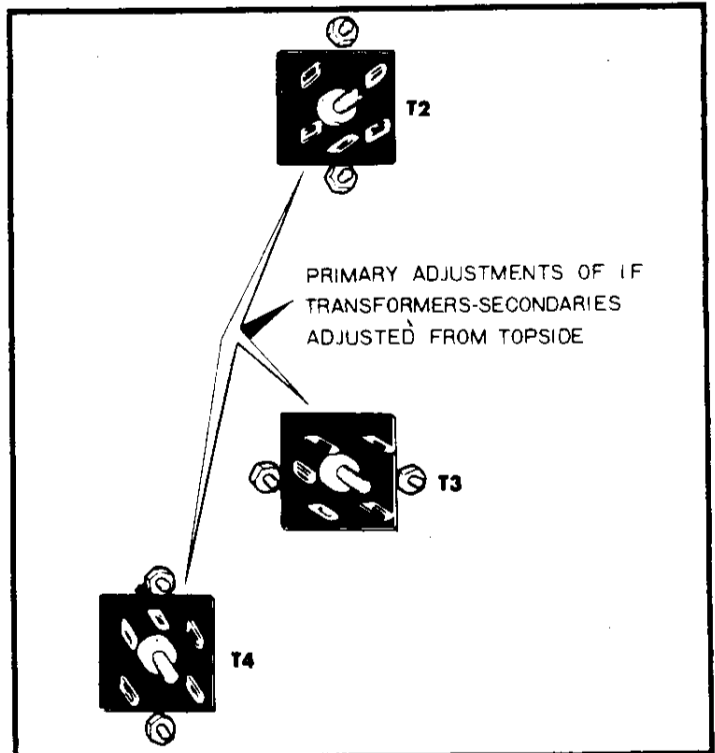
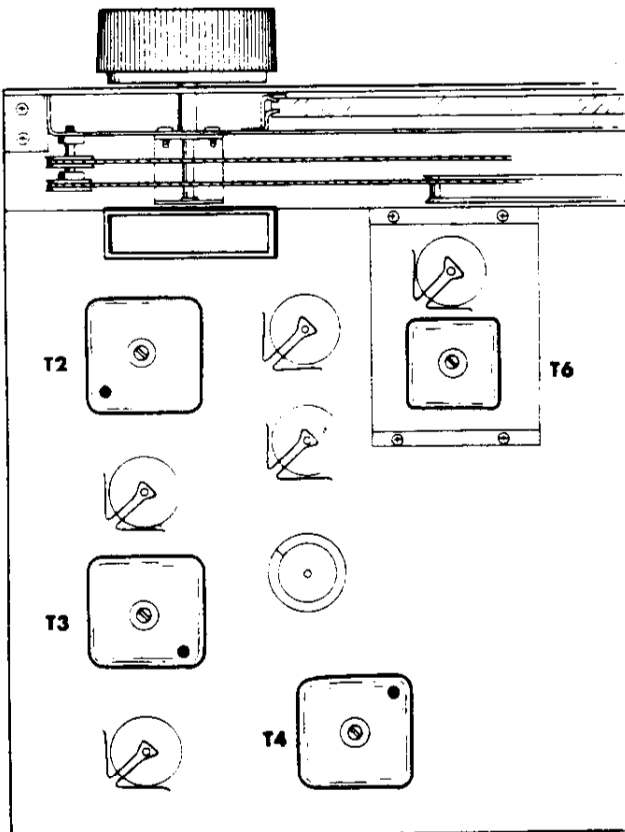

RF ALIGNMENT

1. Replace V3, 6BE6 local oscillator, in its socket.
 2. Using a short jumper wire, connect antenna terminals A2 and E together.
 3. Connect AC voltmeter (3 volt range) and loudspeaker across speaker terminals.
 4. Connect the modulated output of the RF signal generator to antenna terminals A1 and E.
 5. Rotate the ANT TRIM control until the capacitor plates are half-meshed. If the indicator dot on control knob is not at the 12 o'clock position, loosen set screw, place knob in this position and tighten screw again (without disturbing position of capacitor plates). Do not change control from the 12 o'clock position until alignment is completed.
 6. Set all receiver controls as for IF alignment. Set BANDSPREAD pointer at 100 on Logging Scale and make sure FUNCTION switch is on REC AM.
 7. Carry out alignment as indicated in the chart.
- Note: Lower generator output progressively to prevent overloading as circuit come into line.

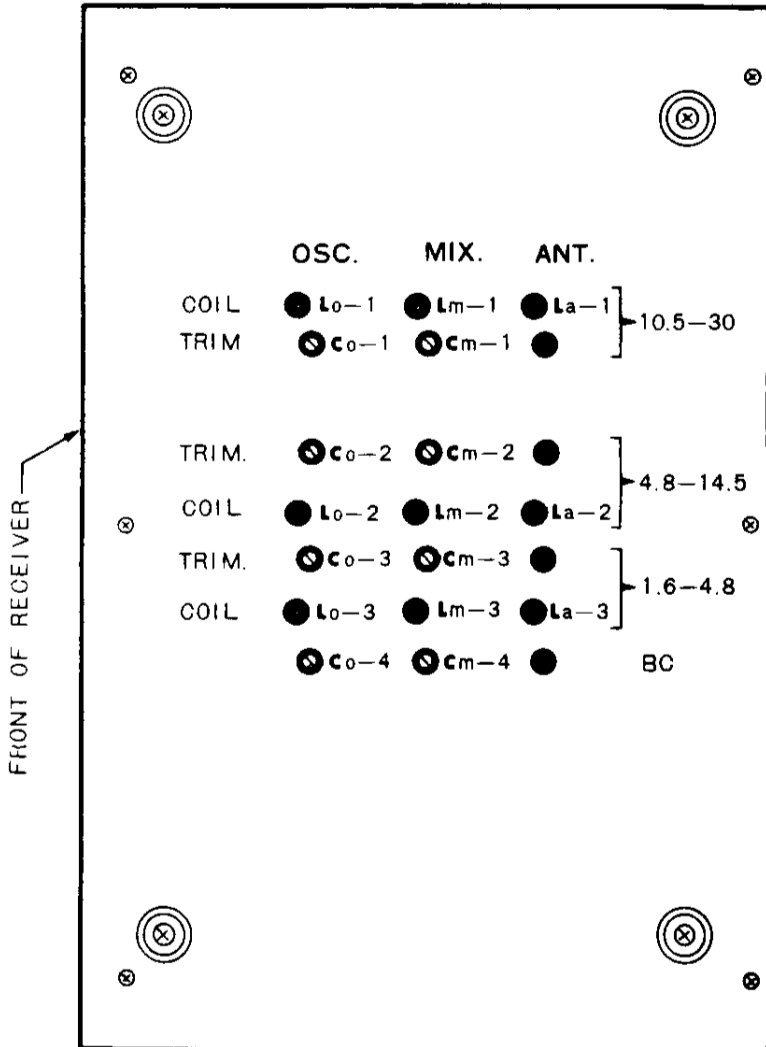

Figure B. LOCATION OF RF ADJUSTMENTS

RF ALIGNMENT CHART

STEP	BAND SELECTOR	SIGNAL GENERATOR	MAIN TUNING	ADJUST	REMARKS	VIEW
1	.55-1.6	.6 MC (600KC)	.6 MC	Co-5 (Osc) *	Adjust for peak reading on voltmeter	Figure A
2	.55-1.6	1.4 MC (1400KC)	1.4 MC	Co-4 (Osc)		
Repeat steps 1 & 2 until calibration is correct at both ends of scale (.6 and 1.4 MC). The remainder of the alignment must be carried out with the bottom cover in place. Remove power first.						
3	.55-1.6	1.4 MC (1400KC)	1.4 MC	Cm-4 (mixer)	Adjust for peak reading on voltmeter	
4	1.6-4.8	2.0 MC	2.0 MC	Lo-3 (Osc)		
5	1.6-4.8	4.0 MC	4.0 MC	Co-3 (Osc)		
Repeat steps 4 and 5 until calibration is correct at both ends of the scale (2.0 and 4.0 MC)						
6	1.6-4.8	2.0 MC	2.0 MC	Lm-3 (mixer)	Adjust for peak reading on voltmeter	
7	1.6-4.8	4.0 MC	4.0 MC	Cm-3 (mixer)		
Repeat steps 6 and 7 until calibration is correct at both ends of the scale (2.0 and 4.0 MC)						
8	1.6-4.8	2.0 MC	2.0 MC	La-3 (Ant)	Adjust for peak reading on voltmeter	Figure B
9	4.8-14.5	5.0 MC	5.0 MC	Lo-2 (Osc)		
10	4.8-14.5	14.0 MC	14.0 MC	Co-2 (Osc)		
Repeat steps 8 and 9 until calibration is correct at both ends of the scale (5.0 and 14.0 MC)						
11	4.8-14.5	5.0 MC	5.0 MC	Lm-2 (mixer)	Adjust for peak reading on voltmeter	
12	4.8-14.5	14.0 MC	14.0 MC	Cm-2 (mixer)		
Repeat steps 11 and 12 until calibration is correct at both ends of the scale (5.0 and 14.0 MC)						
13	4.8-14.5	5.0 MC	5.0 MC	La-2 (Ant)	Adjust for peak reading on voltmeter	
14	10.5-30	13.0 MC	13.0 MC	Lo-1 (Osc)		
15	10.5-30	28.0 MC	28.0 MC	Co-1 (Osc)		
Repeat steps 14 and 15 until calibration is correct at both ends of scale (13.0 and 28.0 MC)						
16	10.5-30	13.0 MC	13.0 MC	Lm-1 (mixer)	Adjust for peak reading on voltmeter	
17	10.5-30	28.0 MC	28.0 MC	Cm-1 (mixer)		
Repeat steps 16 and 17 until calibration is correct at both ends of scale (13.0 and 28.0 MC)						
18	10.5-30	13.0 MC	13.0 MC	La-1 (Ant)	Adjust for peak reading on voltmeter	

*NOTE: On all bands, the oscillator should be set on the high frequency side of the incoming signal.

VOLTAGE MEASUREMENTS

Voltages taken with receiver controls in the following positions

BANDSPREAD pointer at 0 on Logging Scale

MAIN TUNING pointer at 0 on Logging Scale

FUNCTION switch on REC AM

AF GAIN control fully counter-clockwise (minimum)

SELECTIVITY control on AM-CW-SSB

BFO-Q-MULT FREQUENCY control on mid-position (white dot)

BAND SEL on .55 - 1.6

IF GAIN control fully counter-clockwise (minimum)

MVC-AVC switch on AVC

ANL switch on "off" position

Short A1, A2 and E with jumper wire

Voltage selector switch in 117 volt position

SOCKET PIN NUMBERS

	1	2	3	4	5	6	7	8	9
RF									
V1 (6BA6)	0	0	6.3V AC	0	135	135	3.5	-	-
MIXER									
V2 (6BE6)	-7.7	3.6	6.3V AC	0	125	125	0	-	-
OSC									
V3 (6BE6)	-7.7	0	6.3V AC	0	125	125	125	-	-
Q-MULT									
* V4 (6AV6)	**2.2 Mcg	**3.3 K	6.3V AC	0	0	0	135	-	-
1st IF									
*** V5 (6BA6)	0	0	6.3V AC	0	135	135	19	-	-
2nd IF									
V6 (6BA6)	0	0	6.3V AC	0	135	135	19	-	-
Detector, ANL 1st audio									
V7 (6AV6)	-.35	0	6.3V AC	0	-.06	-.08	70	-	-
Audio Output									
V8 (6AQ5)	0	7	6.3V AC	0	200	135	NC	-	-
Rectifier									
V9 (5Y3)	NC	205	NC	200AC	NC	200AC	NC	205	-

* Place FUNCTION switch in Q-MULT position and remove V4 from socket. Check voltage from top of socket (numbering is now counter-clockwise).

** Resistance measurements taken at these pins -- REMOVE AC POWER FROM THE UNIT FIRST. After resistance measurements have been taken, turn the unit on again. Permit 2 minutes for warm-up.

*** Before taking voltage measurements on V5 (see chart above) return the FUNCTION switch to REC-AM.

1. Voltages taken with 20,000 ohms per volt meter and, unless otherwise noted, measured from chassis ground to joint indicated.
2. Line voltage maintained at 117V AC for these measurements.
3. Tolerance on components permits a variation of $\pm 15\%$ in readings.
4. All voltages DC unless otherwise noted.

DIAL CORD STRINGING

Set main or bandspread tuning capacitor as indicated. In both cases, tie dial cord to spring at the START point, leaving approximately 4 inches of cord free at this point. Restring in the

direction indicated, keeping a moderate amount of tension on the cord. Make final tie to free end of cord from spring after cutting off any excess cord.

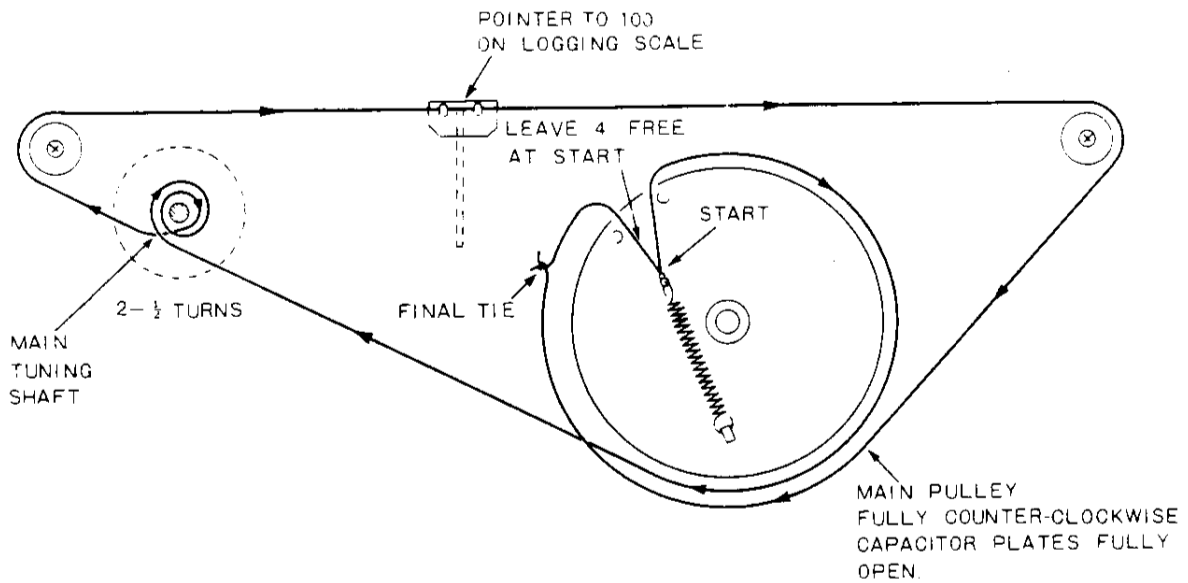

MAIN TUNING DIAL CORD STRINGING

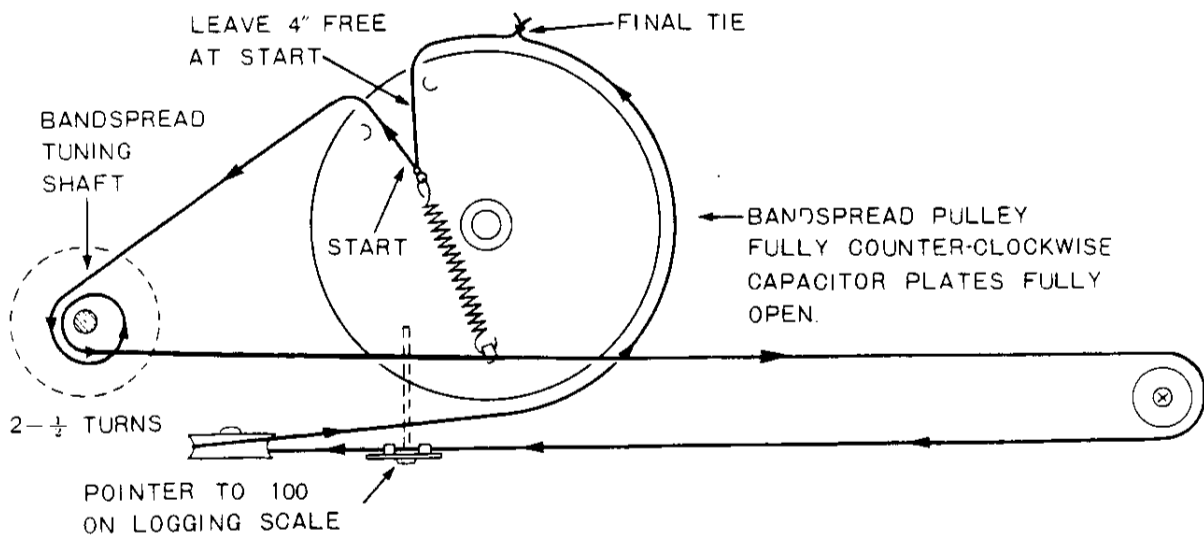

BANDSPREAD DIAL CORD STRINGING

PARTS LIST

CIRCUIT DESIGNATION	DESCRIPTION	QUANTITY
C1, C5	250 mmfd, mica	2
C2, C4, C6, C7, C13, C14, C15, C16, C17, C18, C19	0.01 mfd, disc	11
C3	0.05 mfd, tubular	1
C8, C20, C22	100 mmfd, mica	3
C9	0.005 mfd, disc	1
C10	0.001 mfd, mica	1
C11	0.003 mfd, mica	1
C12	500 mmfd, mica	1
C21, C23, C28	0.01 mfd, tubular	3
C24	10 mfd, electrolytic	1
C25	0.005 mfd, tubular	1
C26, C27	40 — 40 mfd, 300 volt electrolytic	1
C29A	Main Tuning Capacitor	1
C29B	Band Spread Tuning Capacitor	1
C30	Antenna Trimmer	1
C31	50 mmfd, variable capacitor (BFO)	1
R1	47 ohm, 1/4 watt	1
R2, R4	1M (meg) ohm, 1/4 watt	2
R3, R5, R13	330 ohm, 1/2 watt	3
R6	22K (kil) ohm, 1/4 watt	1
R7, R11, R14, R16	1 K ohm, 1/2 watt	4
R8	22 K ohm, 1/2 watt	1
R9, R18	2.2 M ohm, 1/4 watt	2
R10	3.3 K ohm, 1/2 watt	1
R12	100 K ohm, 1/4 watt	1
R15	2.2 K ohm, 1/4 watt	1
R17	47 K ohm, 1/4 watt	1
R19	4.7 M ohm, 1/4 watt	1
R20	220 K ohm, 1/2 watt	1
R21	470 K ohm, 1/4 watt	1
R22	470 ohm, 1 watt	1
R23	2 K ohm, 10 watts	1
R24	10 K ohm, IF Gain Control	1
R25	500 K ohm, Audio Gain Control	1
R26	10 K ohm, Selectivity Control	1
R27	30 ohm, 1/4 watt	1
R28	500 ohm, S-meter Zero Adjust	1
V1, V5, V6	6BA6	3
V2, V3	6BE6	2
V4, V7	6AV6	2
V8	6AQ5	1
V9	5Y3	1
PL	No. 40 light bulb	2
S1	FUNCTION Switch	1
S2	BAND SEL Switch	1
S3	SPDT Input Voltage Selector	1
S4	CW-SSB Switch (On R26)	1

PARTS LIST

CIRCUIT DESIGNATION	DESCRIPTION	QUANTITY
S5	SPST ANL OFF — ON Switch	1
S6	SPST MVC — AVC Switch	1
T1	Power Transformer	1
T2, T3, T4	IF Transformer (455 KC)	3
T5	Output Transformer	1
T6	Q-MULTIPLIER Coil	1
T7	Filament Transformer	1
M1	S-Meter	1
J1	Antenna Input Jack	1
J2	Earphone Jack	1
J3	External Control Jack	1
P1	External Control Plug	1
	Dial Pointer	1
	Small Knobs	6
	Large Tuning Knobs	2
	Antenna Trimmer Knob	1
	Fuse Holder	1
	Q-Multiplier Assembly Chassis	1
	Glass Dial Plate	1
	Fly Wheels	2
	Pilot Light Assembly	1
	Top Cabinet Cover	1
	7-Pin Miniature Socket	8
	Octal Socket	1
	Bottom Cabinet Cover	1
	Main Chassis	1
	.55 — 1.6 MC Antenna Coil, Non-adjustable (located in ANT section)	1
La-3	1.6 — 4.8 MC Antenna Coil, Adjustable	1
La-2	4.8 — 14.5 MC Antenna Coil, Adjustable	1
La-1	10.5 — 30 MC Antenna Coil, Adjustable	1
	.55 — 1.6 Mixer Coil, Non-adjustable (located in the MIXER section)	1
Lm-3	1.6 — 4.8 MC Mixer Coil, Adjustable	1
Lm-2	4.8 — 14.5 MC Mixer Coil, Adjustable	1
Lm-1	10.5 — 30 MC Mixer Coil, Adjustable	1
	.55 — 1.6 MC Oscillator Coil, Non-adjustable (located in the OSCILLATOR section)	1
Lo-3	1.6 — 4.8 MC Oscillator Coil, Adjustable	1
Lo-2	4.8 — 14.5 MC Oscillator Coil, Adjustable	1
Lo-1	10.5 — 30 MC Oscillator Coil, Adjustable	1
Cm-4	.55 — 1.6 MC Mixer Trimmer Capacitor	1
Cm-3	1.6 — 4.8 MC Mixer Trimmer Capacitor	1
Cm-2	4.8 — 14.5 MC Mixer Trimmer Capacitor	1
Cm-1	10.5 — 30 MC Mixer Trimmer Capacitor	1
Co-4	.55 — 1.6 MC Oscillator Trimmer Capacitor	1
Co-3	1.6 — 4.8 MC Oscillator Trimmer Capacitor	1
Co-2	4.8 — 14.5 MC Oscillator Trimmer Capacitor	1
Co-1	10.5 — 30 MC Oscillator Trimmer Capacitor	1