

TABLE 4. ALIGNMENT PROCEDURE

STEP.	S. G. COUPLING AND INPUT SIGNAL	BAND SWITCH POS	RECEIVER DIAL SETTING	ADJUST	OUTPUT INDICATION	ADJUSTMENT LOCATION
Zero "S" meter	No Signal Input	---	---	Zero Adj at rear of receiver	S Meter reads zero	See Figure 2
Align 2nd IF	455 Kc, Mod. 30% at 400 cps. Connect S. G. between pin 7 of V4 and chassis	---	---	Both mechanical filters and IFT2	Adj for maximum reading on S meter	See Figures 6 and 7
Align BFO (Set function switch to SSB-CW)	Set S. G. to 455 Kc unmodulated. Connect S. G. between pin 7 of V4 and chassis	---	---	Core of BFO coil	Zero beat with BFO control set at center mark	See Figure 6
Align 1st IF	2.608 Mc. Connect S. G. between pin 1 of V2 and chassis	---	---	IFT1	Adj for maximum deflection on S meter	See Figures 6 and 7
Align 1st Oscillator	(1) Connect S. G. to ANT terminal. Set CAL adjustment (on front panel) to center mark. Do not move CAL adjustment for remainder of procedure					
	(2) Set S. G. to 3.5 Mc.	3.5	3.5 Mc	3.5 Mc OSC core	Adj for maximum deflection on S meter	See Figure 7
	(3) Set S. G. to 4.0 Mc.	3.5	4.0	3.5 Mc OSC trimmer	"	See Figure 7
	(4) Repeat (2) and (3)					
	(5) Set S. G. to 7.0 Mc	7	7.0 Mc	7 Mc OSC trimmer	"	See Figure 7

(6) Set S. G. to 7.3 Mc	7	7.3	7 Mc OSC trimmer	Adj for maximum reading on S meter	See Figure 7
(7) Repeat (5) and (6)					
(8) Set S. G. to 14.0 Mc.	14	14.0 Mc	14 Mc OSC core	"	See Figure 7
(9) Set S. G. to 14.35 Mc.	14	14.35 Mc	14 Mc OSC trimmer	"	See Figure 7
(10) Repeat (8) and (9)					
(11) Set S. G. to 21.0 Mc	21	21.0 Mc	21 Mc OSC core	Adj for maximum reading on S meter	See Figure 7
(12) Set S. G. to 21.45 Mc	21	21.45 Mc	21 Mc OSC trimmer	"	See Figure 7
(13) Repeat (11) and (12)					
(14) Set S. G. to 28.0 Mc.	28	28.0 Mc	28 Mc OSC core	"	See Figure 7
(15) Set S. G. to 29.7 Mc.	28	29.7 Mc	28 Mc OSC trimmer	"	See Figure 7
(16) Repeat (14) and (15)					
(17) Set S. G. to 50.0 Mc.	50	50.0 Mc	50 Mc OSC core	"	See Figure 7
(18) Set S. G. to 54.0 Mc.	50	54.0 Mc	50 Mc OSC trimmer	"	See Figure 7
(19) Repeat (17) and (18)					

Align ANT and RF Coils	(1) Set S. G. to 3.7 Mc.	3.5	3.7 Mc	Cores of 3.5 Mc antenna and RF coils	Adj for maxi- mum reading on S meter	See Figure 7
	(2) Set S. G. to 7.15 Mc.	7	7.15 Mc	Cores of 7 Mc antenna and RF coils	"	See Figure 7
	(3) Set S. G. to 14.15 Mc.	14	14.15 Mc	Cores of 14 Mc antenna and RF coils	"	See Figure 7
	(4) Set S. G. to 21.2 Mc.	21	21.2 Mc	Cores of 21 Mc antenna and RF coils	"	See Figure 7
	(5) Set S. G. to 28.5 Mc.	28	28.5 Mc	Cores of 28 Mc antenna and RF coils	"	See Figure 7
	(6) Set S. G. to 51 Mc.	50	51.0 Mc	Cores of 50 Mc antenna and RF coils	"	See Figure 7

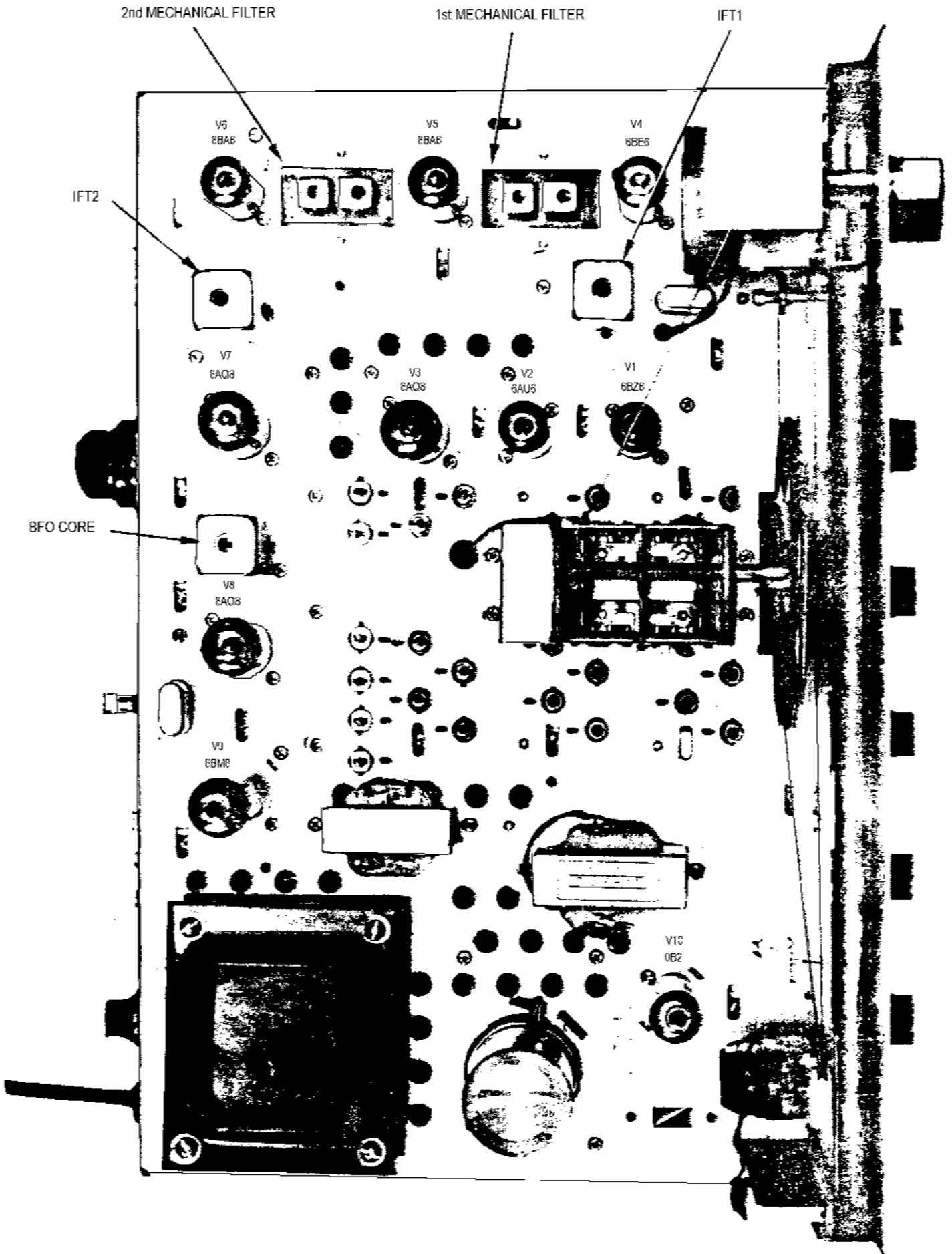
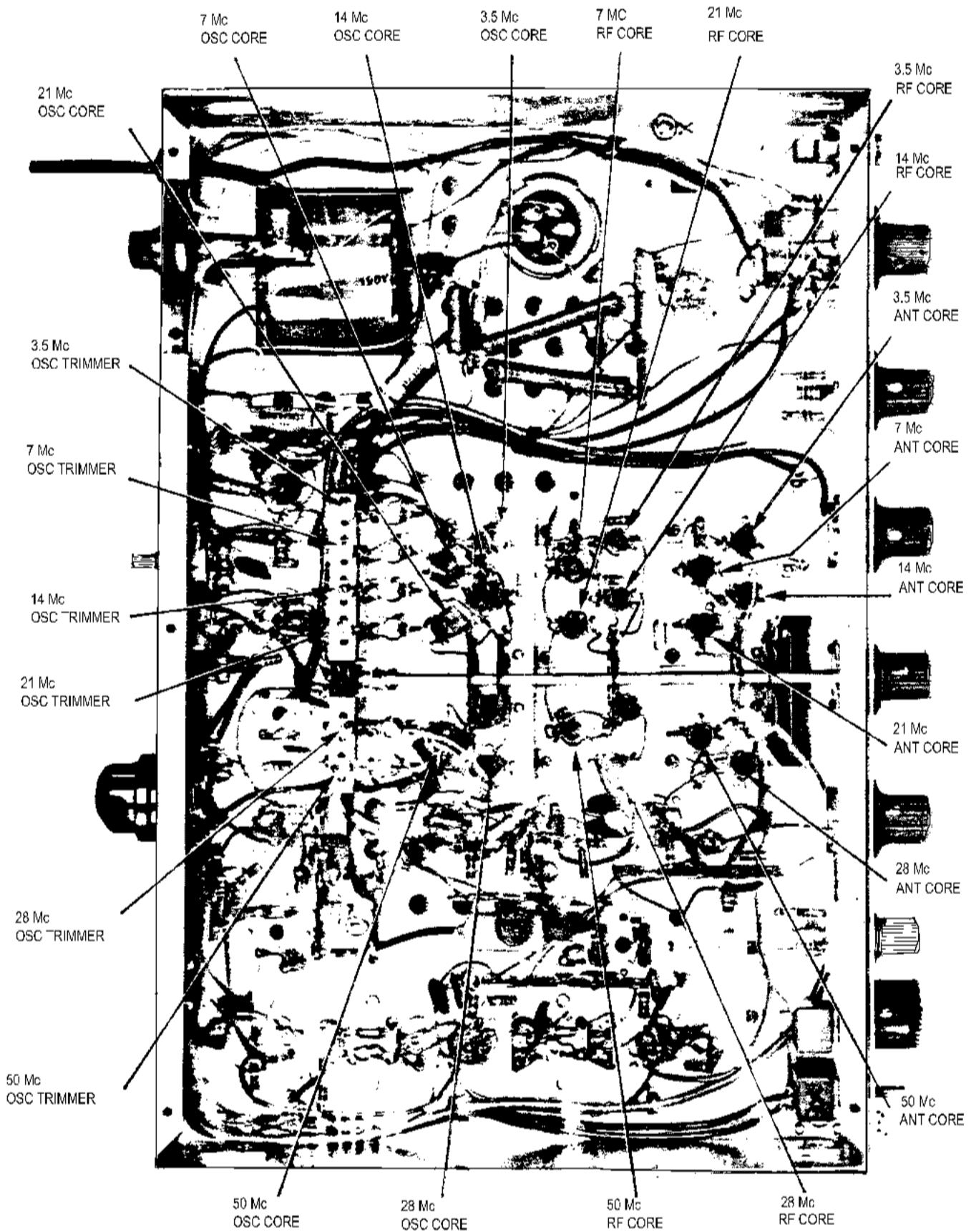
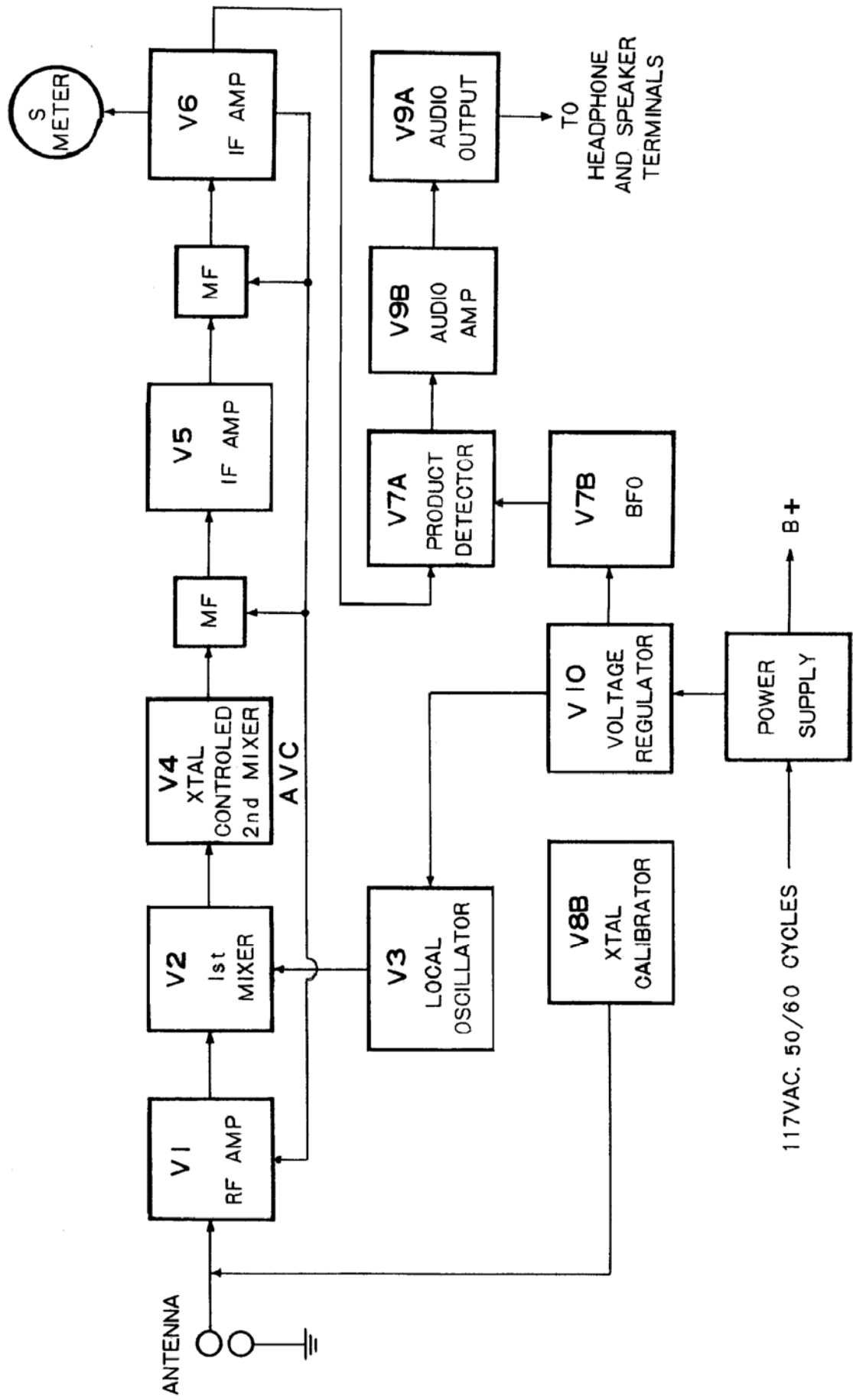

FIGURE 6. ALIGNMENT POINTS (TOP VIEW)



**FIGURE 7. ALIGNMENT POINTS (BOTTOM VIEW)**

# FUNCTIONAL BLOCK DIAGRAM



117VAC, 50/60 CYCLES

B+

### RESISTANCE MEASUREMENTS

Table 3 lists the resistances measured at the tube socket pins. These measurements were

made using a VOM and they may be used as a reference when trying to locate a malfunction in the receiver. All measurements have a tolerance of  $\pm 20\%$ .

**TABLE 3. RESISTANCE MEASUREMENTS**

TUBE	PIN	RESISTANCE (Ohms)	TUBE	PIN	RESISTANCE (Ohms)
V1-6BZ6	1	1.4 meg	V6-6BA6	1	210K
	2	10K		2	0
	3	0		3	0
	4	0		4	0
	5	5.0 meg		5	5 meg
	6	10.0 meg		6	5 meg
	7	0		7	400
V2-6AU6	1	1.4 meg	V7-6AQ8	1	5 meg
	2	0		2	100K
	3	0		3	0
	4	0		4	0
	5	5.0 meg		5	0
	6	5.0 meg		6	5 meg
	7	500		7	50K
V3-6AQ8	1	5.0 meg		8	2 ohms
	2	110K		9	0
	3	550	V8-6AQ8	1	160K
	4	0		2	160K
	5	0		3	2 meg
	6	5.0 meg		4	0
	7	50K		5	0
	8	0		6	5 meg
	9	0		7	100K
V4-6BE6	1	22K		8	0
	2	0		9	0
	3	0	V9-6BM8	1	0 *
	4	0		2	330
	5	5 meg		3	45K
	6	5 meg		4	0
	7	1 meg		5	0
V5-6BA6	1	210K		6	5 meg
	2	0		7	5 meg
	3	0		8	2.2K
	4	0		9	5 meg
	5	5 meg	V10-OA5	1	5 meg
	6	5 meg		2	0
		7	10K	* Depends on pos of VC.	

## VOLTAGE AND RESISTANCE MEASUREMENTS

### VOLTAGE MEASUREMENTS

Table 2 lists the voltages measured at the tube socket pins of the receiver. These measurements can be used as a reference when trying to locate a malfunction in the receiver. The

measurements were made under the following conditions:

Meter used: VOM, 20,000/volt DC, 5,000 ohm volt AC. All measurements have a tolerance of  $\pm 20\%$ .

**TABLE 2. VOLTAGE MEASUREMENTS**

TUBE	PIN	VOLTAGE	TUBE	PIN	VOLTAGE
V1-6BZ6	1	0.0	V6-6BA6	1	NM
	2	18.5		2	0.0
	3	---		3	---
	4	---		4	---
	5	155.0		5	155.0
	6	155.0		6	155.0
	7	0.0		7	4.4
V2-6AU6	1	0.0	V7-6AQ8	1	55.0
	2	0.0		2	-0.09
	3	---		3	0.0
	4	---		4	---
	5	155.0		5	---
	6	155.0		6	34.0
	7	3.0		7	-0.035
V3-6AQ8	1	105.0		8	0.0
	2	0.0		9	---
	3	1.5	V8-6AQ8	1	-0.25
	4	---		2	-0.25
	5	---		3	0.0
	6	80.0		4	---
	7	-2.6		5	---
	8	0.0		6	50.0
	9	---		7	-4.8
V4-6BE6	1	-4.4		8	0.0
	2	0.0		9	---
	3	---	V9-6BMB	1	0.0
	4	---		2	10.2
	5	155.0		3	0.0
	6	32.0		4	---
	7	-1.1		5	---
V5-6BA6	1	NM		6	220.0
	2	0.0		7	155.0
	3	---		8	1.26
	4	---		9	75.0
	5	155.0	V10-0A2	1	110.0
	6	155.0		2	0.0
	7	19.0			



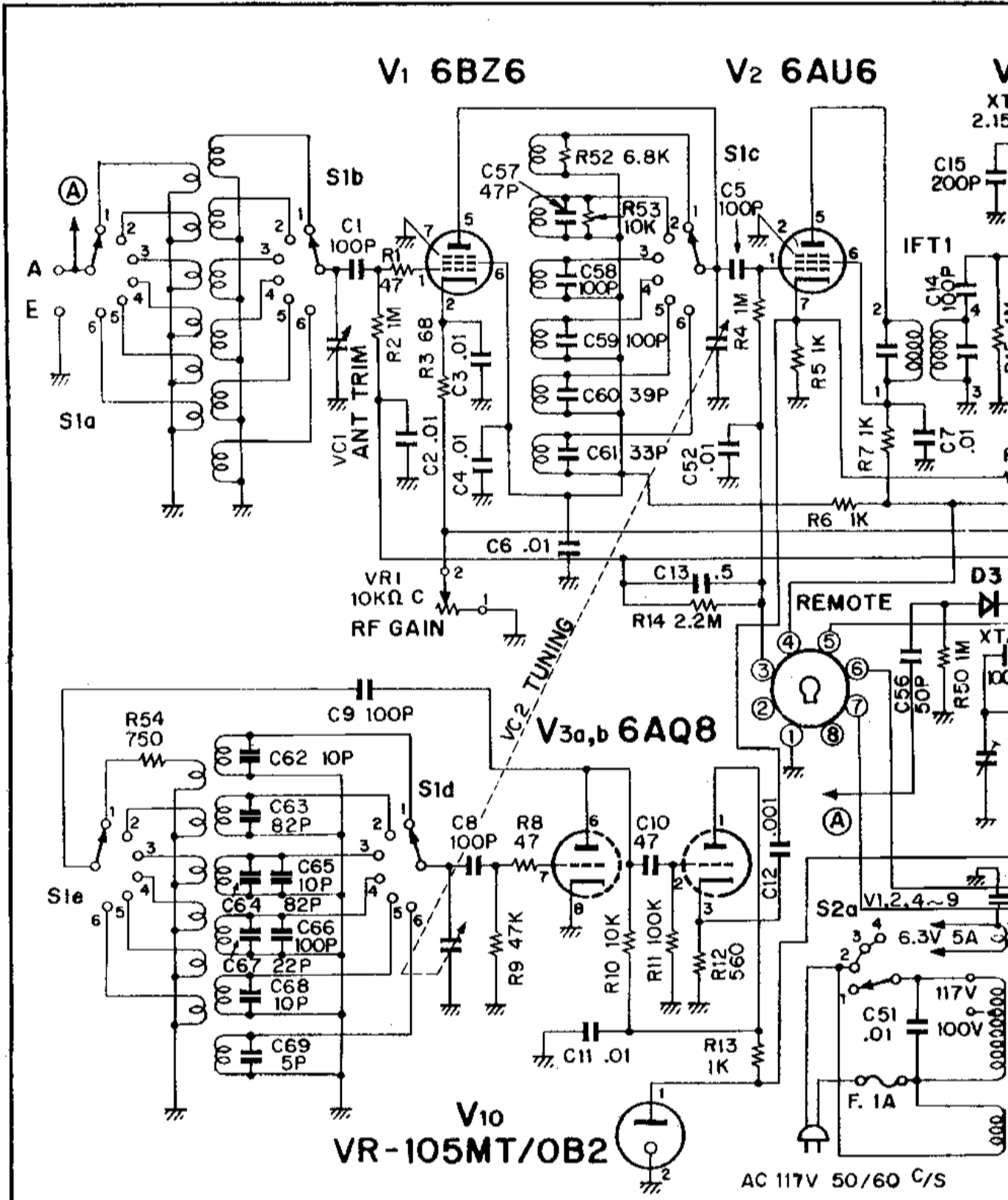

**NOTE**

ALL RESISTORS ARE 1/2WATT UNLESS OTHERWISE SPECIFIED.

ALL RESISTORS VALUE ARE IN OHMS. K=1,000 M=1000,000

S1a~e BAND SW 1-3.5MC, 2-7MC, 3-14MC, 4-21MC, 5-28MC, 6-50MC,

S2a~d FUNCTION SW 1-OFF, 2-REC, 3-STAND BY, 4-SSB CW,

# SCHEMATIC DIAGRAM

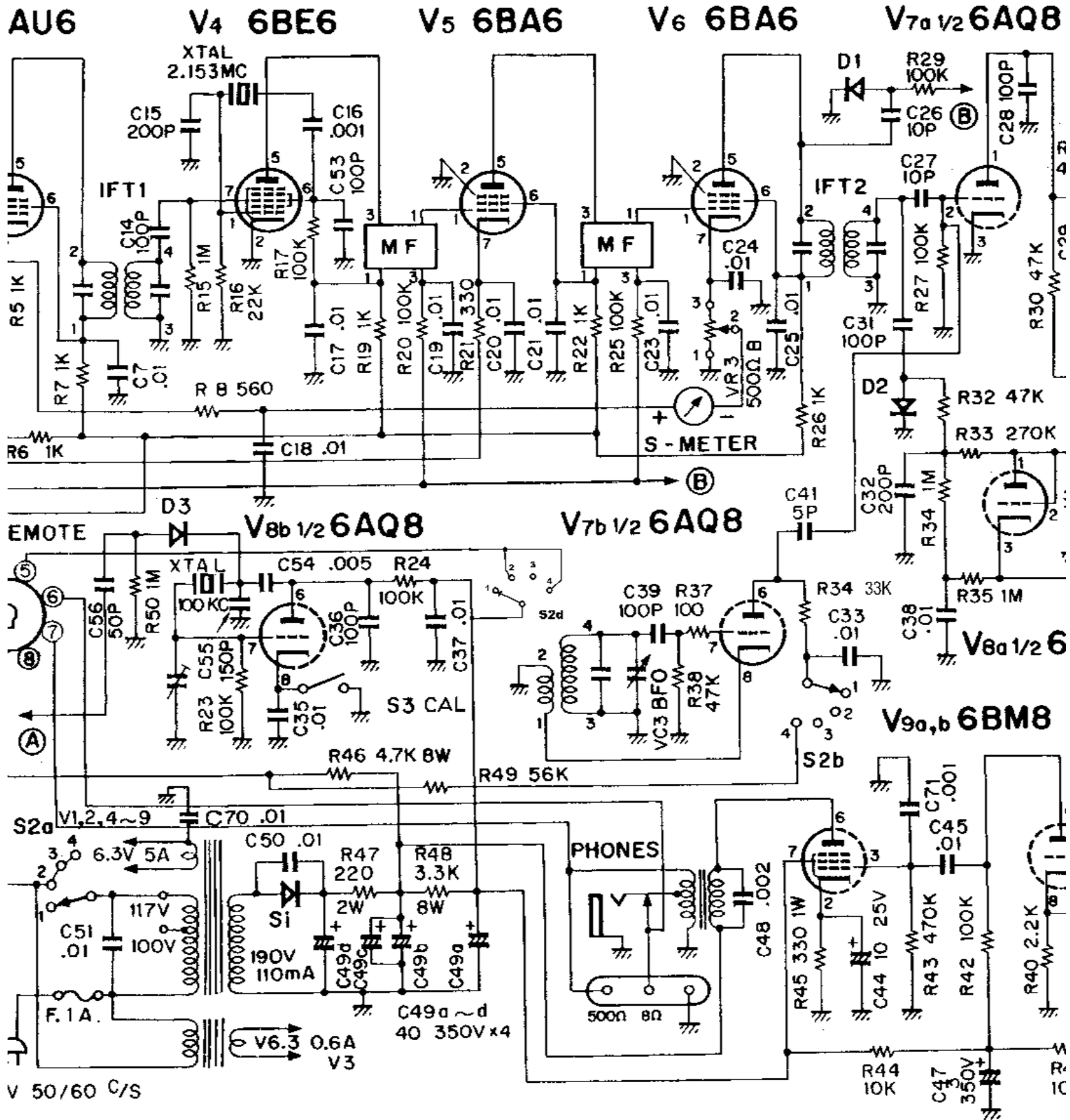

IFIED.  
 0,000  
 -28MC, 6-50MC,  
 -SSB CW,

SCHEMATIC OF THE LAF  
 HAM BAND RECEIVER M

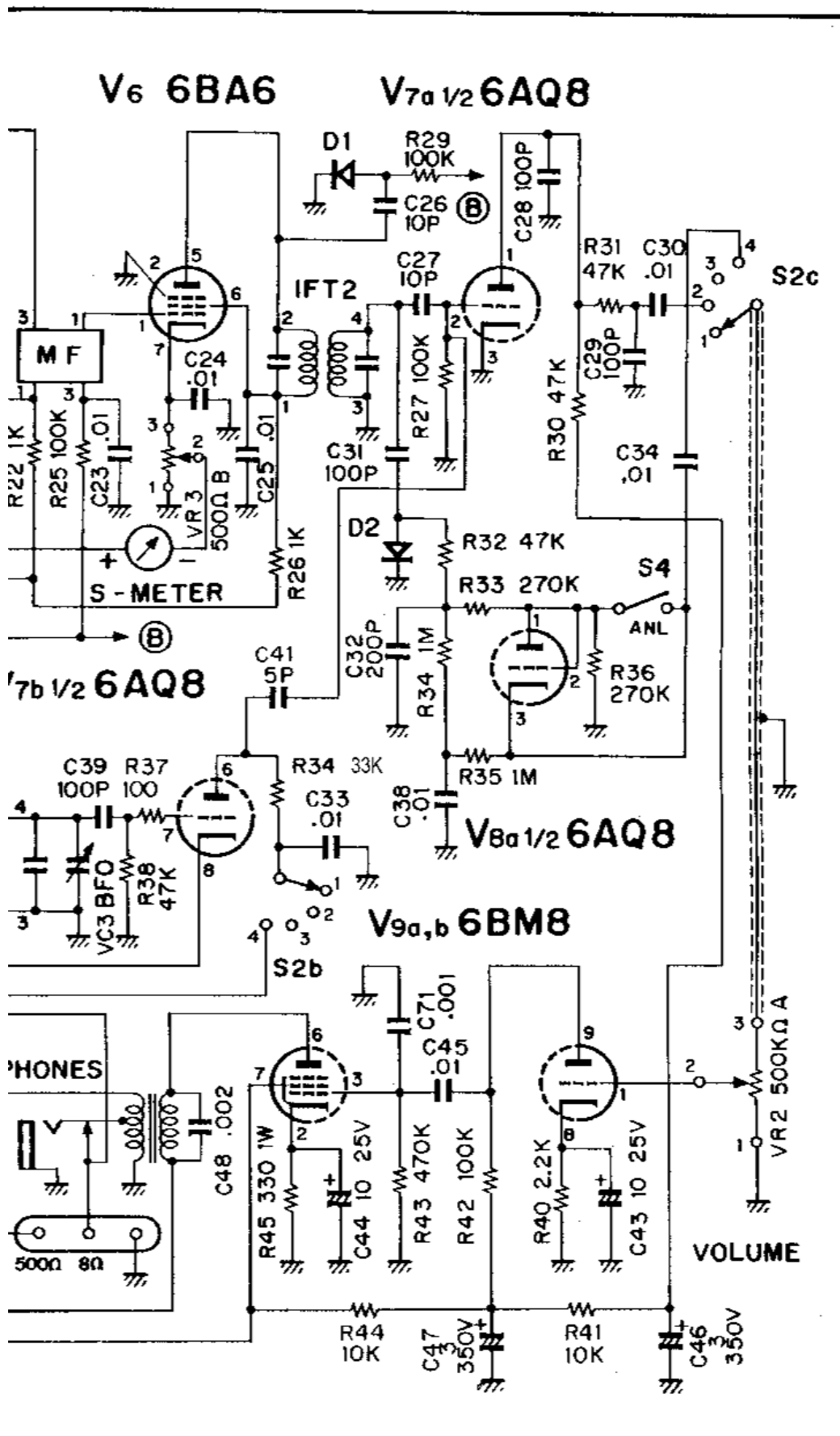

SCHMATIC OF THE LAFAYETTE  
HAM BAND RECEIVER MODEL HA-500

SCHEMATIC DIAGRAM

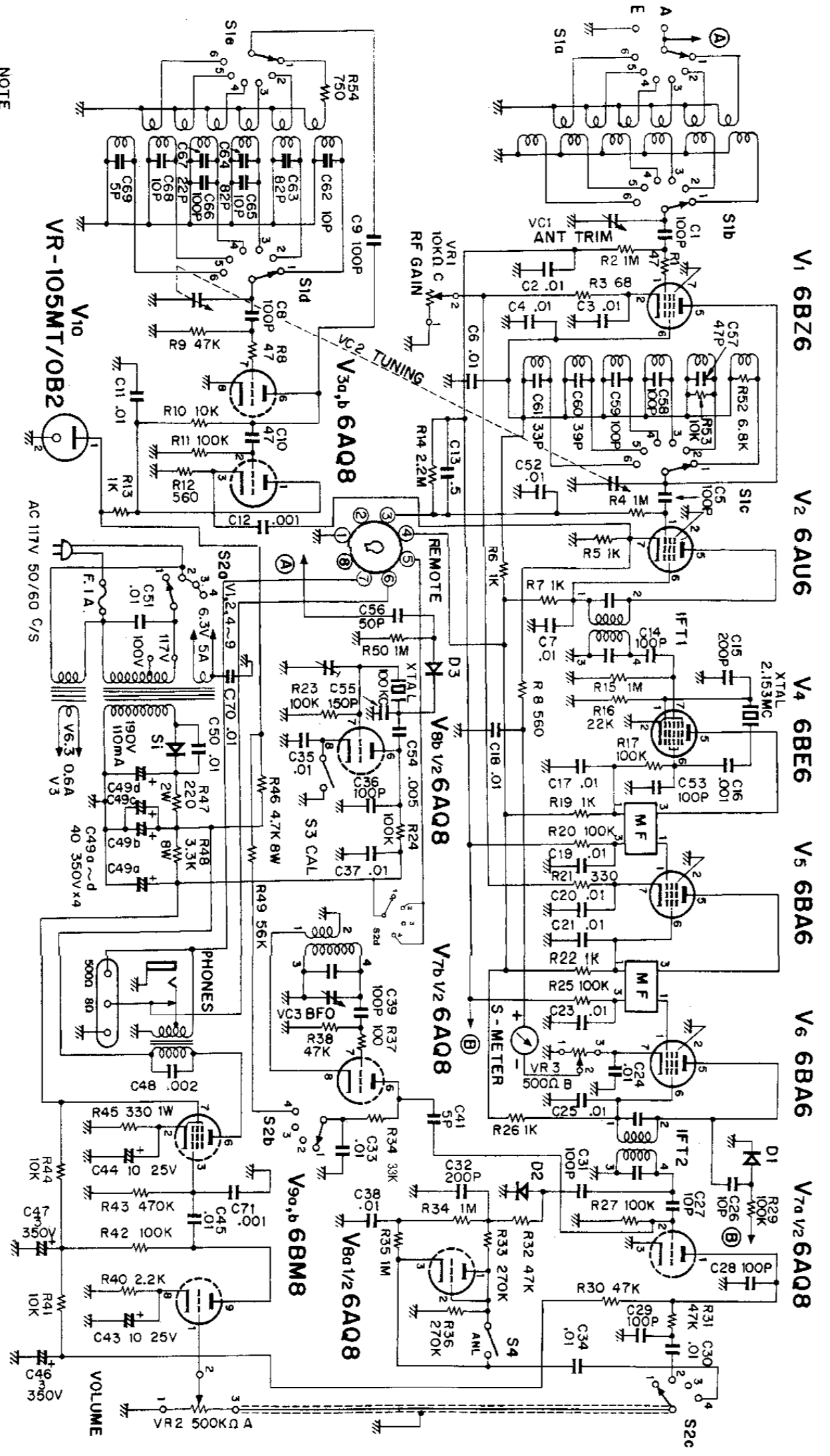

NOTE

ALL RESISTORS ARE 1/2WATT UNLESS OTHERWISE SPECIFIED.

ALL RESISTORS VALUE ARE IN OHMS. K=1,000 M=1000,000

S1a BAND SW 1-3.5MC, 2-7MC, 3-14MC, 4-21MC, 5-28MC, 6-50MC,

S2a and FUNCTION SW 1-OFF, 2-REC, 3-STAND BY, 4-SSB CW,

SCHEMATIC OF THE LAFAYETTE

HAM BAND RECEIVER MODEL HA-500