

RANK Hi-Fi
LEAK 2000 RECEIVER SERVICE MANUAL

INTRODUCTION

The servicing instruction in the manual is divided into two levels :

- (1) Servicing to module level, where the fault is located to a module which can then be replaced.
- (2) Complete servicing, where circuit descriptions, circuit diagrams, test point voltages and alignment instructions are provided to assist the qualified service engineer.

If further assistance is required please contact :

CONTENTS

1. Dismantling the Case
2. Key to Major Components
3. Fault Finding to Module Level
4. Access to Amplifier and Tuner Modules
5. Access to Front Panel Components
6. Restringing
7. Audio Section - Service Details
8. Radio Section - Service Details

1 DISMANTLING THE CASE.

1a To remove top panel.

FIG 1

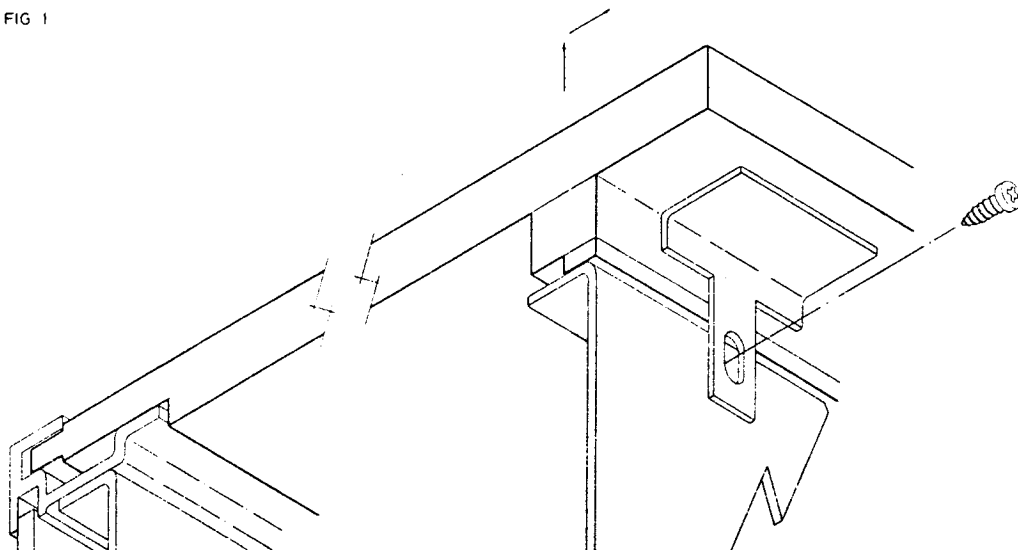

Remove fixing screws as shown from two positions in back panel module. Lift slightly and remove to rear as indicated.

1b To remove side panels.

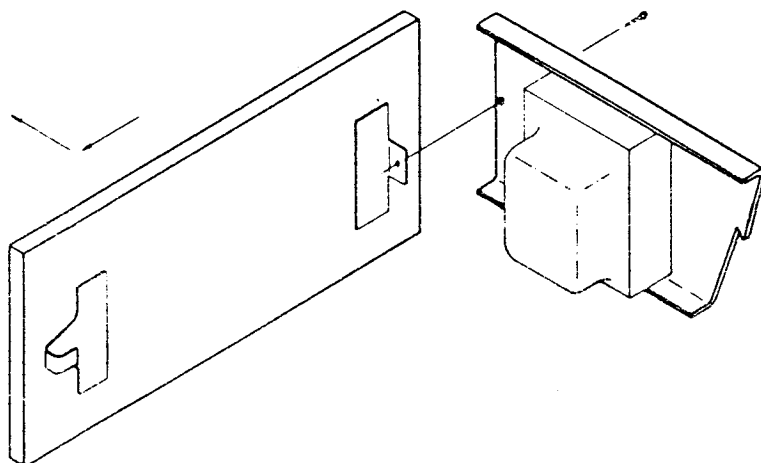

Remove one fixing screw from back panel module, pull forward and remove to side as indicated. Repeat for other side.

1 DISMANTLING THE CASE

1c To remove bottom tray.

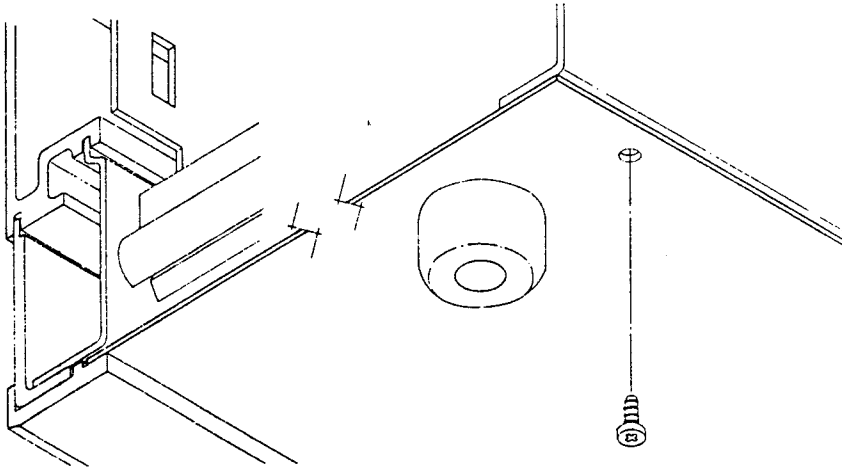

Remove fixing screws as shown from three positions in bottom flange of back panel module and remove bottom tray to rear.

2 KEY TO MAJOR COMPONENTS.

1 FRONT PANEL MODULE.

- 1.1 On/Off Switch.
- 1.2 Tone Control Board Assembly.
 - 1.2.1. Volume Control.
 - 1.2.2. Balance Control
 - 1.2.3. Bass Control.
 - 1.2.4. Treble Control.
- 1.3 Tuning Drive Spindle Assembly.
- 1.4 Tuning Meter.
- 1.5 AM, Wavechange Switch.
- 1.6 Scale Indicator Bulb and Holder; 12v., 2w.
- 1.7 Stereo Indicator Bulb and Holder; 14v, 40mA.

2 . BACK PANEL MODULE.

- 2.1 Transformer.
- 2.2 Mains Outlet Socket.
- 2.3 Switch Bank - 7 way.
- 2.4 Earth Terminal.
- 2.5 Aerial Socket - DIN.
 - 2.5.1. (Upper) - A. M.
 - 2.5.2. (Lower) - F. M. 300 ohm.

3 AMPLIFIER MODULE.

- 3.1 Amplifier Board Assembly.
 - 3.1.1. Power Supplies.
 - 3.1.2. Main Amplifiers.
 - 3.1.3. Disc Pre-amplifiers.
- 3.2 Capacitor, 6800uf.
- 3.3 Heat Sink.
- 3.4 Screening Contact Clip.
- 3.5 Speaker Protection Circuit.

- 4.2 Tuner Gang.
- 4.3 Ferrite Rod Aerial.

2 KEY TO MAJOR COMPONENTS.

1 FRONT PANEL MODULE.

- 1.8 Mute Potentiometer
- 1.9 Switch Bank - 4 way
- 1.10 Switch Bank - 6 way
- 1.11 Switch Bank - 4 way
- 1.12 Phones Socket.

2 BACK PANEL MODULE.

- 2.1 Transformer.
- 2.4 Earth Terminal.
- 2.6 Aerial Socket - Coaxial FM 75ohm.
- 2.7 Input Socket - 5 Pin DIN.
- 2.8 Speaker Sockets - 2 Pin DIN.
 - 2.8.1. Speakers 1 R & L.
 - 2.8.2. Speakers 2 R & L.
- 2.9 Mains Supply Fuse and Holder.

- 3.2 Capacitor, 6800uf.
- 3.3 Heat Sink.

4 TUNER MODULE.

- 4.1 Tuner Board Assembly.
- 4.2 Tuner Gang.
- 4.3 Ferrite Rod Aerial.

3 FAULT FINDING TO MODULE LEVEL

Electrically the receiver consists of:-

The Audio Section which incorporates the Main Amplifier Module and the Control Amplifier Circuit.

The Radio Section comprising the Tuner Module together with the ferrite rod aerial and wavechange switch.

Power Supplies for the Tuner Module and the Control Amplifier are taken from the Main Amplifier Module.

The following check procedures are a guide to help fault find the Receiver to 'Module' level. For more detailed servicing information please refer to sections 7 and 8.

3.1 Fault Locating Chart.

Set up the Receiver as follows:-

Plug the Receiver into the mains supply.

Plug the Speakers into the speaker 1 socket.

Depress the speaker 1 button, set all the other buttons into the out position.

Set the balance, bass and treble controls into the centre position.

Turn the volume control fully anticlockwise, adjust to the required level during testing.

Connect an FM aerial.

	CHECKS	YES	NO
1	<u>INITIAL CHECK</u> Switch on the receiver. Does the receiver light up?	Proceed to Check 2.	Read Section 3.2.
2	<u>MAIN AMPLIFIER CHECK</u> Press the PRE/MAIN switch in. Feed a signal (500 mV. 1kHz) into the PRE/MAIN socket Check for left and right channel outputs	Proceed to Check 3.	Main Amplifier Module or associated wiring suspect. Read Section 3.3.
3	<u>CONTROL AMPLIFIER AND FUNCTION SWITCH CHECK</u> Release PRE/MAIN switch. Select AUX function. Feed a signal (100 mV, 1 kHz) into the AUX input socket. Adjust volume and check for left and right channel outputs.	Proceed to Check 4.	Control amplifier or associated wiring suspect. Read Section 3.4 and 3.5.

FAULT FINDING TO MODULE LEVEL

	CHECKS	YES	NO
4	<u>DISC PRE AMP CHECK</u> Select DISC function . Feed a signal (5 mV. 1 kHz) into the disc input socket. Adjust volume and check for left and right channel outputs.	Proceed to Check 5.	Disc pre-amplifier or associated wiring suspect. Read section 3.6.
5	<u>AM RADIO CHECK</u> Select AM function. Tune to a station of LW then MW. Check for left and right channel outputs .	Proceed to Check 6.	Tuner Module or associated wiring suspect. Read Sections 3.7 and 3.8
6	<u>FM RADIO CHECK</u> Select FM function. Turn mute control fully anti-clockwise. Tune to a station (STEREO TRANSMISSION). Adjust volume and check for left and right channel outputs AFC, MUTE and MONO function.		Tuner Module or associated wiring suspect. Read Sections 3.7 and 3.9.

3.2 Unit completely dead on both channels

- Check 3.2.1 Mains supply voltage.
 Check 3.2.2 Transformer primary voltage
 Check 3.2.3 Transformer secondary voltage.
 Check 3.2.4 DC voltage across main smoothing capacitors (on amplifier module).
- If have 3.2.1 and not 3.2.2. investigate mains fuse; ON/OFF switch and associated wiring.
 If have 3.2.2 and not 3.2.3 transformer is faulty.
 If have 3.2.3 and not 3.2.4. investigate secondary fuses (on amplifier PCB). If blown replace. If they fail on switch-on, then fault on amplifier module. To replace module see section 4. If fuses OK proceed to 3.3 to check the main amplifier.

3.3 Main Amplifier Check.

- (a) Press in switch 2.3 "PRE AMP & MAIN AMP"
 (b) Connect speakers to speaker 1 output sockets .
 (c) Press in switch 1.11 "spkr 1".
 (d) Inject a signal at the input pin of both power amplifiers in turn.

Check 3.3.1 for signal on left channel .
 Check 3.3.2 for signal on right channel .

If left and right output signals present proceed to 3.4.

3 FAULT FINDING TO MODULE LEVEL

If not present check continuity of wiring from the speaker sockets to the amplifier outputs. If wiring OK then fault on Power Amplifier Module. To replace module see section 4.

3.4 Control Amplifier Check

- (a) Release switch 2.3 "PRE-AMP & MAIN AMP"
- (b) Inject a signal at the input pin of both control amplifiers in turn.
Turn volume control clock-wise approximately 30°.

Check 3.4.1 for signal on left channel.

Check 3.4.2 for signal on right channel.

If present proceed to 3.5.

If not present check supply voltage on control amplifier PCB.

If supply not present then supply lead to control amplifier is faulty or fault on amplifier PCB.

If supply is present check continuity of wiring from the outputs of the control amplifier to the input of the power amplifier. If OK then fault on Control Amplifier. To replace control amplifier see section 5.

3.5 Function Switch Check.

- (a) Inject a signal at the output pins of function switch interconnect PCB (1.10).

Check 3.5.1 for signal on left channel.

Check 3.5.2 for signal on right channel.

- (b) Select "aux" function and inject a signal at aux input connections on interconnect PCB.

Repeat checks 3.5.1 and 3.5.2.

If have 3.5.1 and 3.5.2 for procedure (a) but not for procedure (b), then have fault on function switch interconnect board. To service function switch see section 5. If do not have 3.5.1 and 3.5.2 for either procedure (a) or (b) then investigate wiring between function selection switch and control amplifier input.

3.6 Disc Pre-Amp Check.

Select disc function. Inject a signal (5mV 1kHz) into the disc input.

Check 3.6.1 for continuity of wiring between disc input socket and disc pre-amp input.

Check 3.6.2 for output from disc pre-amplifier.

Check 3.6.3 for input to function interconnect PCB.

Check 3.6.4 for output from function interconnect PCB.

If have 3.6.1 and not 3.6.2 then fault on amplifier module.

If have 3.6.3 and not 3.6.4 then fault on function switch. To service function switch see section 5.

3.7 Tuner Module Check.

Check 3.7.1 for power supply to the Tuner Module.

If NOT present then faulty connection between power supply and Tuner Module or fault on Amplifier Module Power Supply, 3.1.1.

3 FAULT FINDING TO MODULE LEVEL

3.8 AM Radio Check.

- (a) Select AM by pressing function button 'AM' on the front of the unit, turn the volume control clock-wise approximately 30°.
- (b) Inject a signal at the audio output pins on the AM section of the Tuner PCB.

Check 3.8.1 for signal on the speakers.

If NOT present then faulty audio output wiring or fault on function switch interconnect board. If present then fault on Tuner Module; or wavechange switch (1.5) and associated wiring; or aerial connections. To remove tuner module see section 4.

3.9 FM Radio Check.

- (a) Select FM by pressing function button "FM" on the front of the unit, turn the volume control clock-wise approximately 30°.
- (b) Inject a signal at the audio output pins on the FM section of the Tuner PCB.

Check 3.9.1 for signal on left channel.

Check 3.9.2 for signal on right channel.

If NOT present then faulty audio output wiring or fault on function switch interconnect board.

If present then fault on Tuner Module or associated wiring.

To remove Tuner Module see Section 4.

4 ACCESS TO AMPLIFIER AND TUNER MODULES.

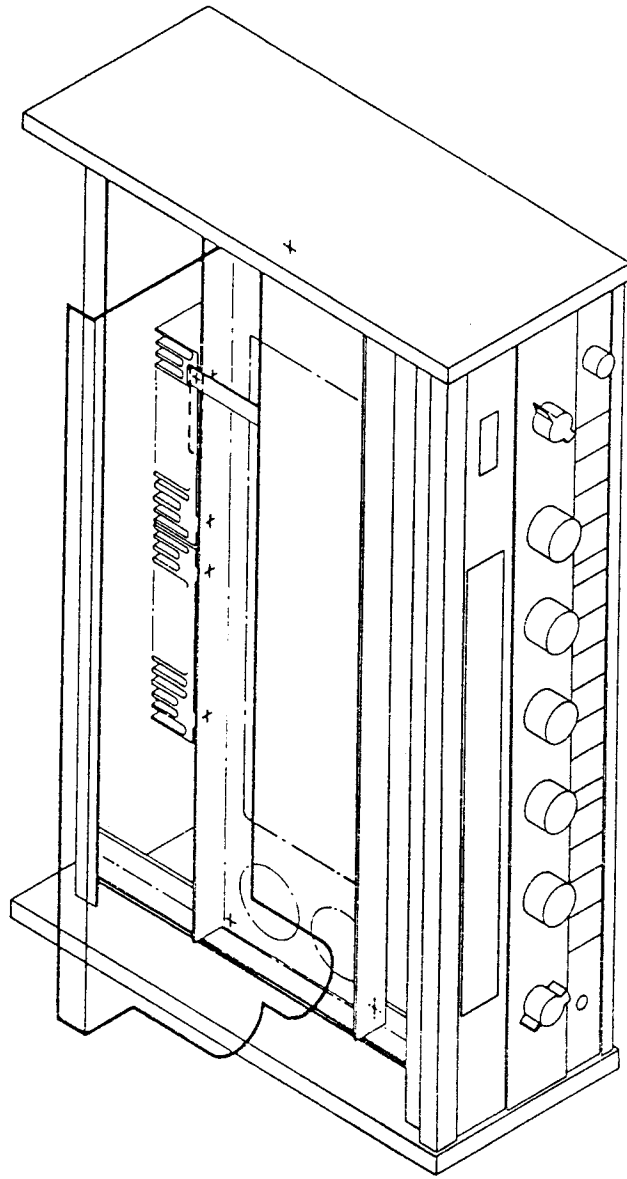

4.1 To Raise Main Amplifier Module.

Unplug top connections to the Amplifier Module PCB pins marked "LAMPS", "+16 v". Remove four fixing screws from the Heat Sink Assembly and three "MODULE FIXING SCREWS" from the side rails. Remount Amplifier Module (3) in position shown. The receiver can be operated with the module in this position but the stereo beacon and the scale lamps will not illuminate.

4 ACCESS TO AMPLIFIER AND TUNER MODULES

4.2 To Remove the Main Amplifier Module (Complete with Main Heat Sink).

Disconnect receiver from the mains supply. Unplug all connections to the Amplifier Module, noting the position of the groups of leads.

Remove four fixing screws fastening the Heat Sink to the Tuner Module and three amplifier "module fixing screws" from the side rails.

The module then lifts out.

To replace the module reverse the procedure above.

4.3 To Remove the Tuner Module.

Disconnect the receiver from the mains supply.

Transfer the tuning drive drum from the tuner gang spindle to the transfer bracket. See section 6.1.

Unplug the 16 volt supply leads from the amplifier module.

Invert the receiver and:

Unplug all connections to the Tuner Module.

Unscrew four fixing screws from the Heat Sink .

Unscrew four module fixing screws .

Lift the Tuner Module out of the receiver.

5 ACCESS TO FRONT PANEL COMPONENTS.

To service the function switch, phone socket and mute potentiometer, the bottom appearance parts only need removing. See section 5.1.5.

Also, by unscrewing and moving the centre function switch away from the receiver, access can be gained to the underside of the Control Amplifier.

To remove the Control Amplifier, on/off switch and wavechange switch, it is necessary to remove the top appearance parts. See sections 5 1.1 to 5 1.4

To remove either switch, unscrew the hexagon fixing nut.

To remove the Control Amplifier, unplug all connections, unscrew the four hexagon nuts holding the controls to the front panel. Ease the assembly out towards the rear of the receiver.

5.1 REMOVAL OF APPEARANCE PARTS.

- 5.1.1 Remove four screws (a) and lift off. TOP FASCIA STRIP as indicated.
- 5.1.2 Remove SCALE INSERT.
- 5.1.3 Remove Control Knobs from their shafts by firmly and carefully pulling.
- 5.1.4 Remove Fascia Fixing Clips (b) from two positions in front panel module. Lift MAIN FASCIA STRIP and remove over Control Knob Shafts as indicated.
- 5.1.5 Remove four screws (c) and remove BOTTOM FASCIA STRIP "mute level" knob and FASCIA INSERTS.

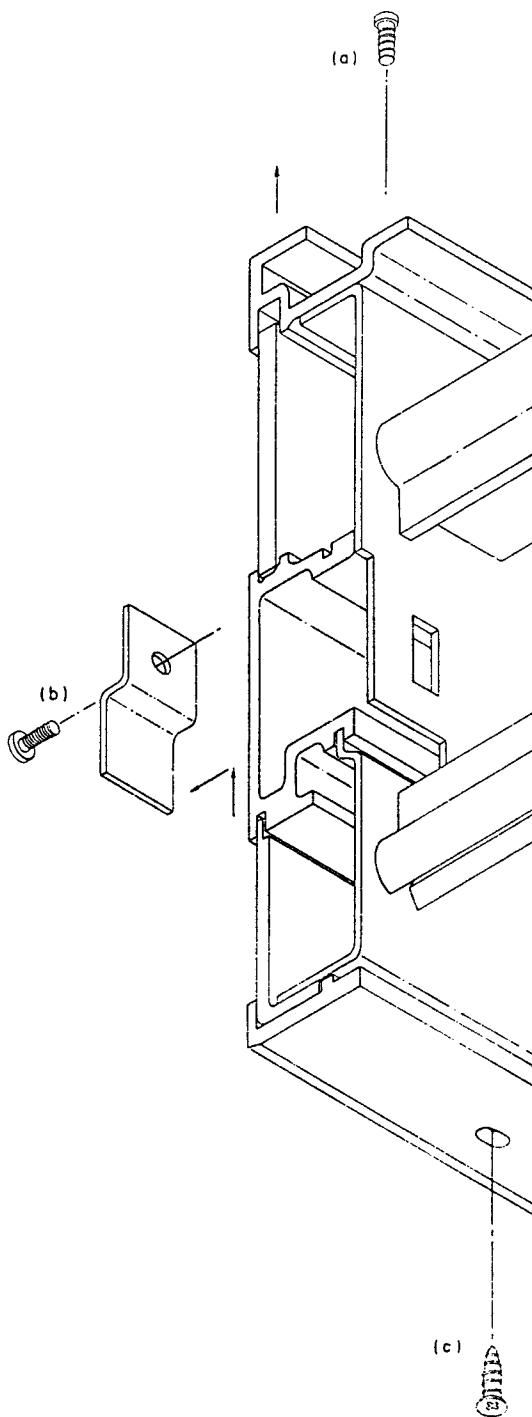

RESTRINGING

- 6.1 Fit Transfer Bracket (A) to Tuning Spindle Support Bracket. Loosen two screws in boss of Drive Drum (B) and transfer Drive Drum from Tuner Gang Spindle.
- NB: In the absence of a Transfer Bracket it is essential to secure the Tuner Drive Cord to the Drive Drum before removing the Drive Drum from the Tuner Gang Spindle.
- 6.2 Set Drive Drum (B) on Transfer Bracket (A) with notch at 3 o'clock position as shown in Stringing Diagram.
- 6.3 Fit Spring (flat loop end) to tag (D) - Cut cord to 1.44 m long.
- 6.4 With cord end approximately 50 mm at right hand side of Tuning Drive Pulley (C), bring cord around pulleys (H & G) - run full length and around pulleys (F & E). Bring cord onto Drive Drum (B) and through notch - pass cord through free end of spring and return cord through notch. Wrap cord in a clockwise direction two full turns around Drive Drum (B) - bring cord on to Tuning Drive Pulley (C) and wrap in an anticlockwise direction two full turns, wrapping cord away from front panel. Bring cord through eyelet (J) and pass other end of cord through eyelet in opposite direction.
- 6.5 Pull on free ends of cord until Tension Spring is extended by 50%. Check that cord is around all pulleys before squeezing eyelet up to trap cord in position, and knot ends together.
- 6.6 Close the Tuning Gang, slide the drive drum on to the Tuning Gang Spindle and lock into place with the two screws. Position the pointer K at the zero position on the log scale.

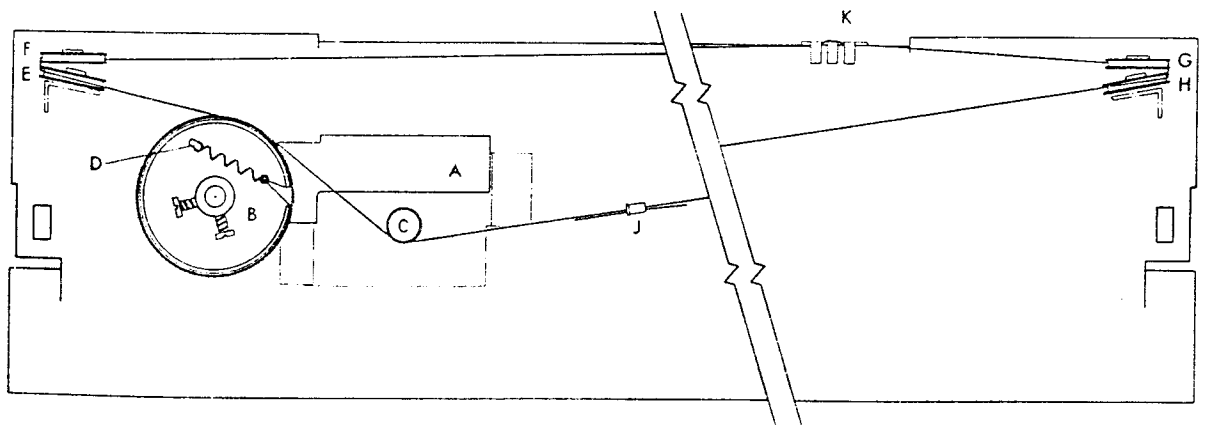

AUDIO SECTION

7a System Description :-

The audio system comprises :-

- (a) Disc pre-amplifiers (3.1.3.), main power amplifiers (3.1.2) and stabilised power supplies (3.1.1.) mounted on the amplifier module ((3))
- (b) Function Selection Switch (1.10) and tone control circuitry (1.2.) mounted on the front panel ((1)).

The main supply transformer (2.1) mains outlet sockets (2.2), mains supply fuse (2.9) and voltage selector (voltage tapped version only) are mounted on the back panel module ((2)). Also on the back panel are the signal input and output sockets (2.7) and associated with these sockets is a bank of seven switches (2.3), five of which are used to perform the following functions :-

DISC function input sensitivity "HIGH SENSITIVITY" (2.2mV) "LOW SENSITIVITY" (6mV) for full power output.

AUX function input sensitivity "HIGH SENSITIVITY" (140mV) "LOW SENSITIVITY" (550mV) for full power output.

TAPE function output impedance "OUTPUT HIGH" (10K) or "OUTPUT LOW" (100K).

CASSETTE function output impedance "OUTPUT HIGH (10K) or "OUTPUT LOW" (100K).

PRE-AMP & MAIN AMP "NORMAL" or "SEPERATE".

(Tone control amplifier outputs and main amplifier inputs are available at socket "PRE-AMP & MAIN AMP" on the back panel).

The two remaining switches are associated with the speaker output sockets 2.8.2. mounted on the back panel. These and speaker output sockets 2.8.1. are of the two pin DIN type. The switch functions are :-

"NORMAL" or "MATRIX" - In the Matrix position the left and right channels are connected to give (R-L and L-R) signals which can be fed to two rear channel speakers.

"NORMAL" or "HIGH POWER" - In the high power mode the output of the right channel main amplifier is connected to the input of the left channel main amplifier via a resistor and the signal is fed into the right channel input socket. Hence with a speaker connected across the outputs of the two amplifiers the system operates in a "High Power Mono Mode".

7 AUDIO SECTION

7b Main Amplifier Specification.

Unless otherwise stated all specifications apply for 6 ohm speakers, and values are typical. Noise measurement bandwidth 20Hz-20kHz.

Distortion Limited Output Power.

4 ohm speakers : greater than 40 + 40 watts
6 ohm speakers : greater than 35 + 35 watts
8 ohm speakers : greater than 30 + 30 watts
(both channels sine wave driven at 1kHz, 0.5% THD)

Total Harmonic Distortion

All powers up to 30 watts, 1kHz : less than 0.1%
At 1 watt, 1kHz : 0.01%
At 30 watts, 10kHz : 0.1%
Intermodulation Distortion : 0.1%
(70Hz and 5kHz in ratio 4 to 1)

Power Bandwidth

2dB down relative to 35 watts : 10Hz to 40kHz
(0.5% THD, both channels driven)

Damping Factor

Measured at 80Hz : 40

Residual Hum and Noise

Volume control minimum : 1mV maximum
Input sensitivity for 35 watts : 830mV
Input resistance : 47kohms
Frequency response (-2dB) : 20Hz-50kHz
Hum and noise : -90dB
Crosstalk at 10kHz : -50dB

Input Function Sensitivity:-

Disc Input

Sensitivity at 1kHz for 35 watts : 2.2mV or 6mV
Input resistance : 47kohms
Frequency response : Compensated to IEC 98
fine groove characteristic
Hum and noise : better than - 65dB
Input overload margin : -35dB
Crosstalk at 10kHz : -35dB

Tape/Cassette/Aux Inputs.

Sensitivity for 35 watts : 140mV
Input resistance : 100kohms
Frequency response (\pm 1.5dB) : 25Hz-40kHz
Hum and noise : better than -80dB
Crosstalk at 10kHz : -40dB
Alternative Aux. sensitivity : 550mV

Tape/Cassette Output.

Output high : 140mV
Output low (DIN standard) : 1.4mV/kohm
(for 30% FM modulation)

7 AUDIO SECTION

7c Power Supplies:

U.K. Market:-

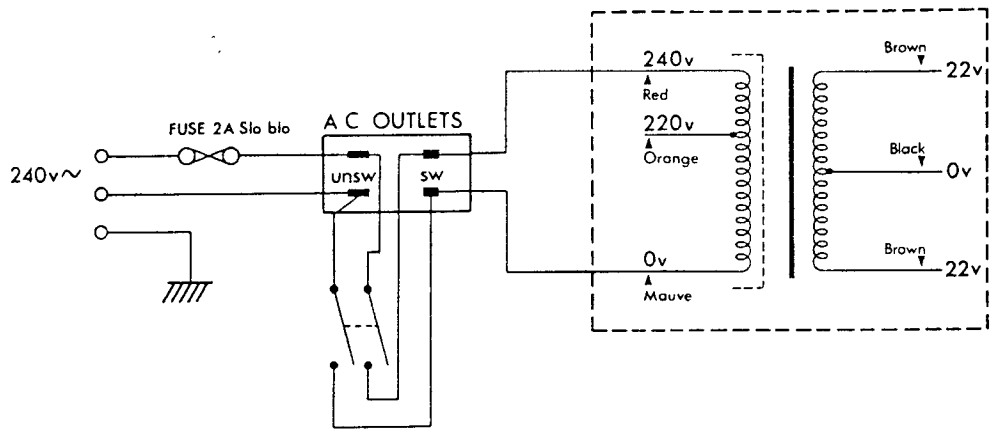

Scandinavian Market:-

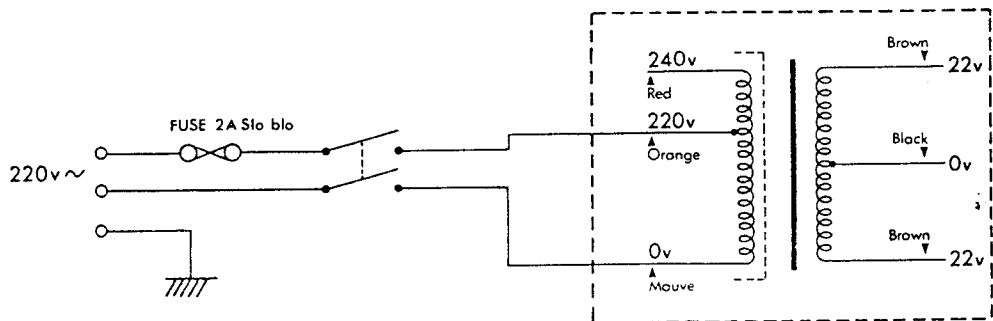

Voltage Selector Version:-

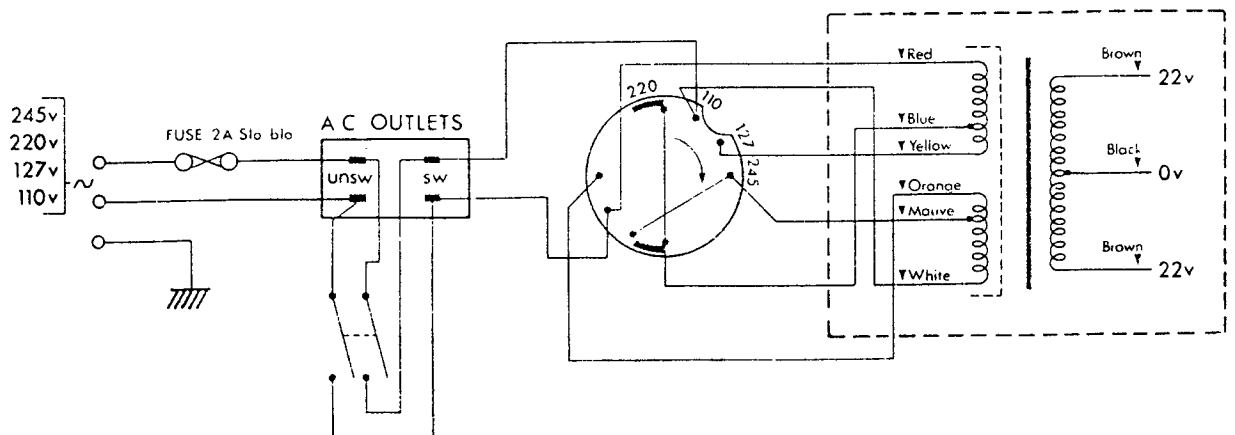



1. Left Output
2. Earth
3. Left Input
4. Right Output
5. Right Input

Component Values

- R1 100 ohms
- R2 100 ohms
- R3 820 K ohms
- R4 68 K ohms
- R5 33 K ohms
- R6 33 K ohms
- R7 68 K ohms
- R8 100 K ohms
- R9 100 K ohms
- R10 100 K ohms
- R11 100 K ohms
- R12 10 K ohms
- R13 10 K ohms
- R14 10 K ohms
- R15 10 K ohms
- R16 10 K ohms
- R17 10 K ohms
- C1 .01 uF
- C2 .01 uF
- C3 .01 uF
- C4 .01 uF

Component Ref. Part No's

1.2	162.02
1.6.	482.21
1.10	523.16
1.10.1	456.66
1.11	523.17
1.12	536.06
2.3	523.18
2.7	536.18
2.8.1	536.17
2.8.2	536.17
3.1.	153.02
3.2	396.01
3.3.1	504.09
3.3.2	505.03
3.3.3	504.09
3.3.4	505.03
3.5	152.09

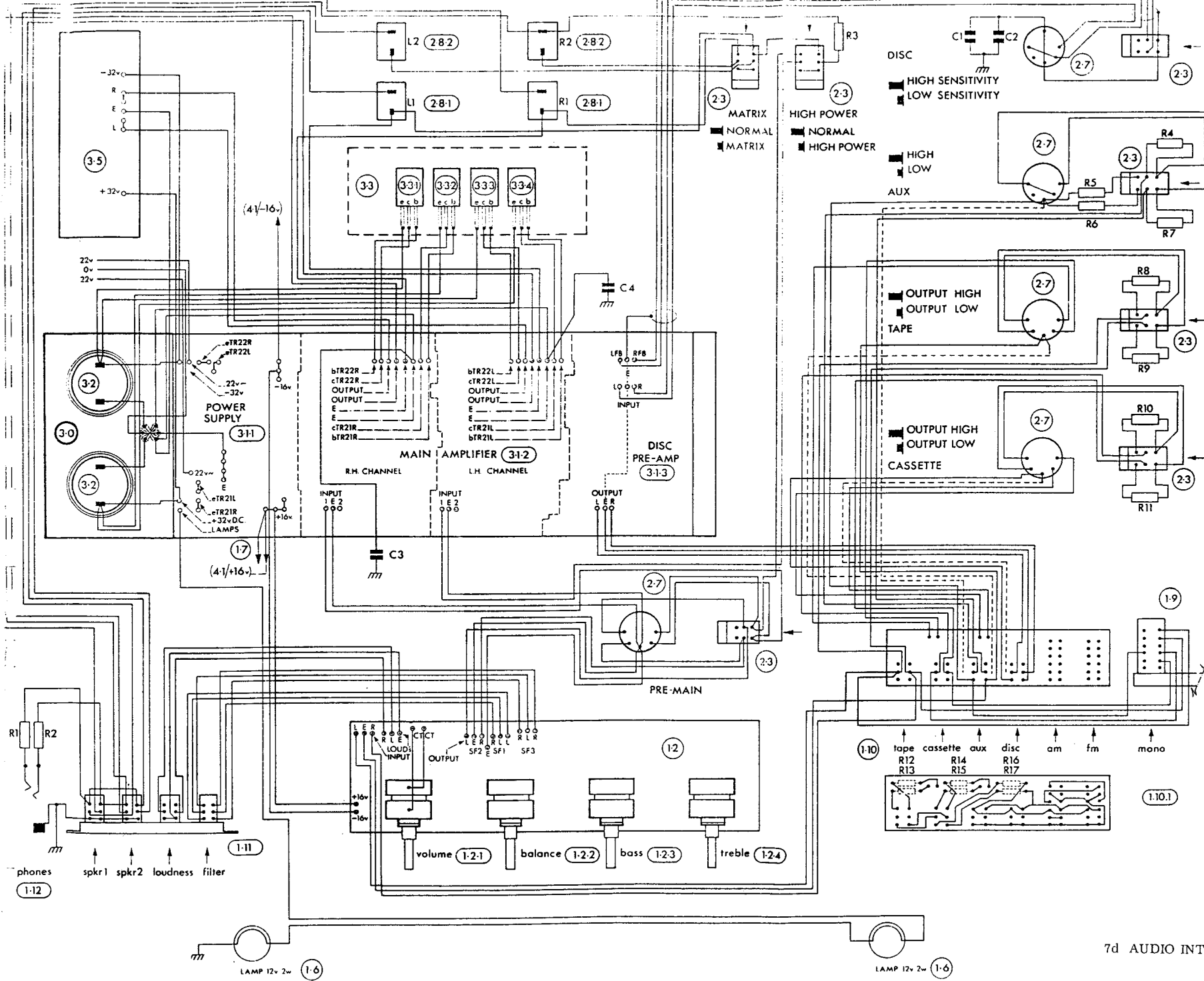

7d AUDIO INTERCONNECT DIAGRAM.

7 AUDIO SECTION

7e Amplifier Module Circuit Description

Power supply:-

The centre tapped secondary of the mains transformer (2.1) is connected via the fuses F1, F2 and then via D2, D3, D4 and D5 to the two 6800uF electrolytic capacitors producing a positive and negative supply rail.

These rails supply the two main amplifiers directly, and the remaining circuitry via two series stabilisers. The positive stabiliser (the negative one being complimentary) consists of an emitter coupled transistor pair TR1, TR4 which compares a fixed proportion (via R5, R6) of the 16 volt output, with a 12 volt reference from Z1. A decrease in output voltage causes the current TR1 to fall, hence increasing the collector current in TR4 consequently providing increased output current from TR3 which serves to correct the original error. Under short circuit conditions, the output current is limited by the action of R11 and R9 which both serve to limit the base current in TR3. Since the Zener Z1 is supplied from the regulated output via R13 and D6, R2 is added to guarantee starting up of the regulator.

Power Amplifier:-

The input signal is coupled via R16 (or R15) and C6 to the input point at the base of TR7. The DC coupled amplifier comprises TR7, TR8 an emitter coupled input pair, TR10 a PNP inverter and TR12, an emitter follower, driving the fully complimentary output comprising TR19, 20, 21 and 22. The system is inverting and negative feedback is thus provided by R30, C10, R18, C7, R17, and its associated components control quiescent current in the output pair. The quiescent current setting is 90mA with the amplifier cold and is adjusted by means of VR1 and monitored in the supply rail feeding the emitter of TR21. Of the remaining transistors in the amplifier TR9 monitors the current in TR12 by means of R23 shunted by C9 and provides current limiting by clamping the input to TR10 under fault conditions. In a similar way TR14 is controlled by TR11 to provide a constant current i. e. high impedance collector load for the pre-drivers TR10, TR12. The complementary transistor pairs TR15, TR16 and TR17, TR18 provide output current limiting. The output current is controlled by comparing the voltage across the low value emitter resistor R36, R37 with the base-emitter voltage of the appropriate sensing transistor TR16 or TR17. As soon as either of these transistors conducts sufficiently to turn on the other one of its pair, they both conduct together and remain locked in this condition until the polarity of the audio signal reverses. This 'snap' action at a fixed output current provides ideal protection even in complete short circuit conditions since the drive to both the driver (TR19 or TR20) and the output transistor (TR21 or TR22) is removed until normal conditions prevail. The input to the main amplifier is clamped to earth for a period of approximately 3 seconds by TR26 and associated components D8, C27, R52, R53 to suppress any transient pulses which may occur during switch on.

7 AUDIO SECTION

7e Amplifier Module Circuit Description (cont.) :-

Disc Pre-Amp:-

The circuit consists of an emitter coupled transistor pair TR23, TR24 coupled to the grounded emitter PNP transistor giving an overall non-inverting system.

The input is direct coupled from the magnetic cartridge to TR23 to minimise low frequency flicker noise. Negative feedback to TR24 is provided by R45, C16, C15, R44 with R42, R43, C14 providing the lower limb of the potential divider network. The R. I. A. A. playback characteristic is provided by the feedback components listed above with R43 acting to reduce the gain with the "DISC" function switch (2.3) in the "LOW SENSITIVITY" position.

7f Speaker Protection Circuit

The speaker protection circuit is designed to blow the a.c. fuses, if for any reason the output from the amplifier swings to either of the supply voltages and stays there for more than 0.5 seconds. This eliminates the risk of prolonged DC current flowing through the speaker voice coil causing permanent damage.

The circuit operates as follows:-

The inputs to TR1 and TR2 are connected to the outputs of the main amplifiers via R1 and R2. Under normal operating conditions TR1 and TR2 are in the off state due to the filtering action of C1. If the amplifier outputs swing up to a DC level and remain there, either TR1 or TR2 depending on the polarity of the amplifier output voltage will trigger the triac, which in turn will blow the main a.c. fuses

To avoid premature triggering of the protection circuit when servicing the main amplifier, disconnect the two wires connecting the protection circuit to the amplifier outputs.

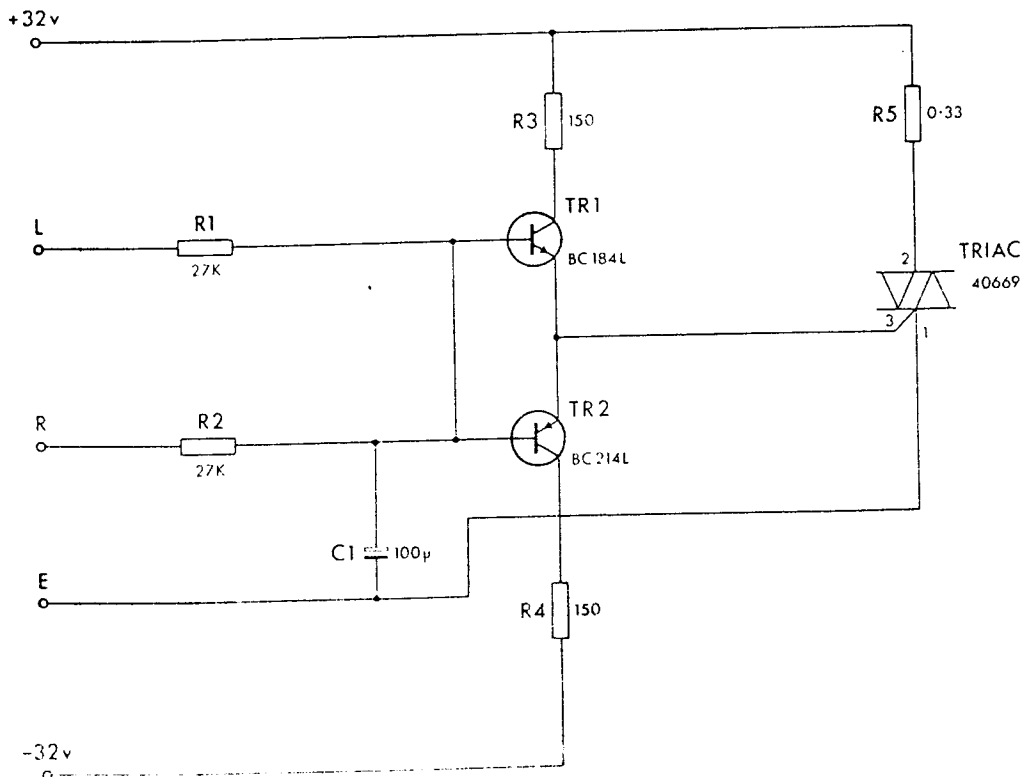

7 AUDIO SECTION

7g Test Point Voltage Chart

All measurements taken with respect to earth potential using an AVO model 8 or equivalent. The voltages shown in the chart are nominal values intended as a guide to fault finding, and were measured with the amplifier inputs connected to signal earth.

Power Amplifier Test Point Voltage Chart

Test Point	Voltage	Test Point	Voltage
Pin 22V	22 a.c.	TR6 Emitter	31-
Pin 22V	22 a.c.	TR6 Collector	16-
Pin e TR21R	32+	TR7 Base	0
Pin e TR22L	32-	TR8 Base	0
TR1 Base	12+	TR8 Emitter	0.6-
TR1 Emitter	11.3+	TR8 Collector	31+
TR2 Base	12.0-	TR13 Emitter	1.5-
TR3 Emitter	26+	TR13 Collector	1.2+
TR3 Collector	16+	TR26 Base	2.7-
TR4 Base	12+	TR26 Emitter	0
TR5 Base	12-	Pin OUTPUT	0
TR5 Emitter	11.3-		

Pre-Amplifier Test Point Voltage Chart.

Test Point	Voltage	Test Point	Voltage
TR25 Emitter	15+	TR23 Base	0
TR25 Collector	5+	TR23 Emitter	0.6-
R47-R49 Junction	13-	TR24 Base	0

7h Parts List

Component	Part No.
Amplifier Module Assembly Complete.3	153.00
6800uF Electrolytic Capacitor 3.2	396.01
Printed Circuit Board Assembly 3.1	153.02
Rectifiers (D2, D3, D4, D5)	501.18
R36, R37	200.03
Tr21 Power Transistor PNP	505.03
Tr22 Power Transistor NPN	504.09

Quiescent Current setting 90mA. See 7e

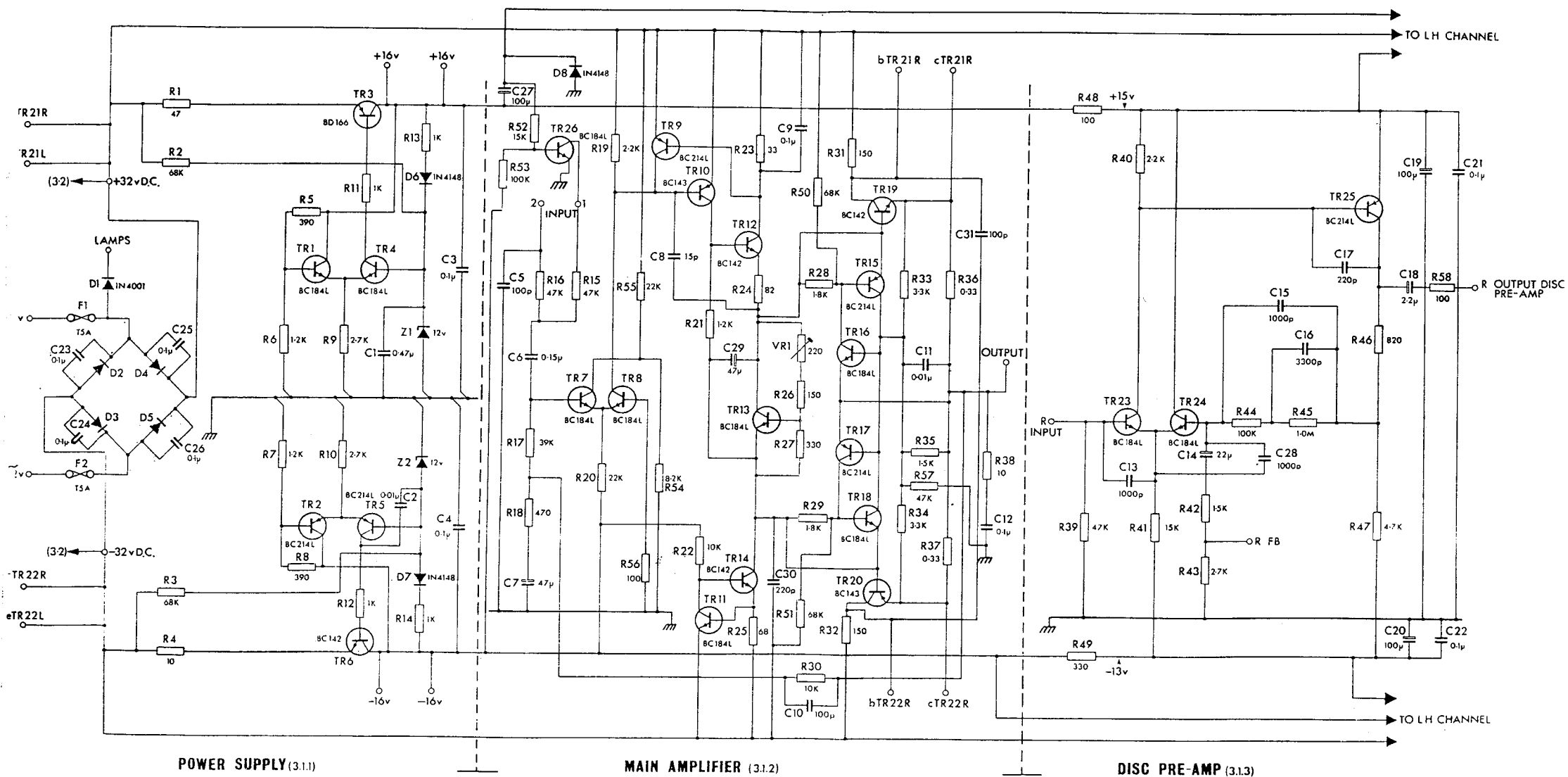

7 AUDIO SECTION

7j Tone Control Circuit Description

The appropriate audio signal selected by the Function Selection Switch (1.10) is connected to the top of the volume control VR2. This linear control is centre-tapped and loaded by R1 and VR1 on the right channel and R2 on the left channel. These resistors give the control a logarithmic law and VR2 allows balancing of the channels at half rotation of the volume control. When "loudness" is selected at switch bank 1.11, C1 and C2 are added into circuit to provide bass boost at low volume settings. TR1 provides impedance transformation after which the signal is fed to the normal Baxendale type feedback tone control. The amplifier section consists of TR2 and TR3, an emitter coupled NPN pair connected to TR4, a PNP inverter.

L1, C15 and R14 form a 12db per octave scratch filter selected by "filter" at switch bank 1.11.

7k Tone Control Amplifier Specification

Treble Control	:	+13dB at 15kHz
Bass Control	:	+13dB at 50Hz
Filter	:	-3dB at 5KHz
		-10dB at 10kHz
Loudness	:	+10dB at 50Hz
		(-40dB volume setting)

7 AUDIO SECTION

7j Tone Control Circuit Description
 7k Tone Control Amplifier Specification

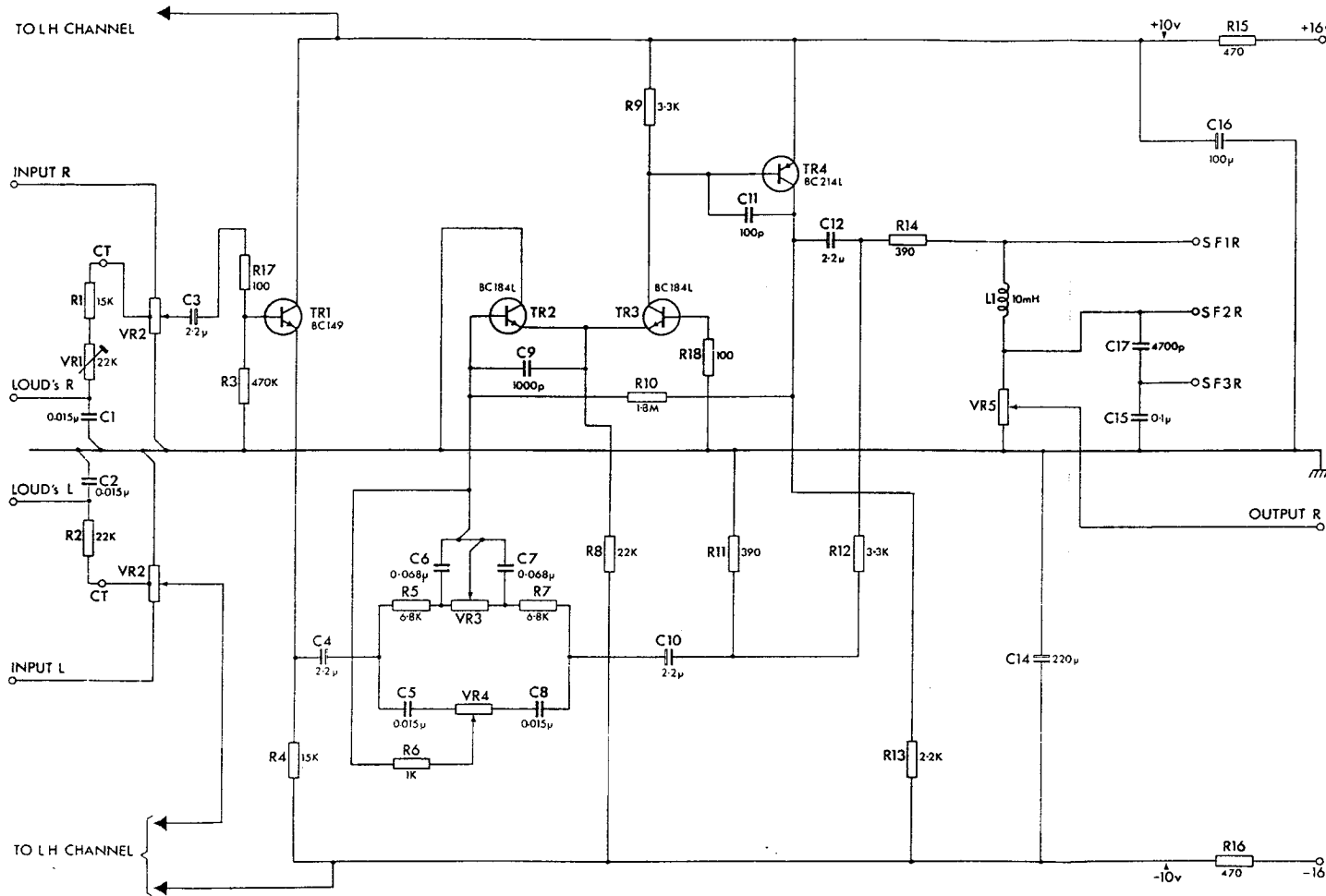

7l Test Point Voltage Chart.

All measurements taken with respect to earth potential using an Avo Model 8 or equivalent. The voltages shown in the chart are nominal values intended as a guide to fault finding and were measured with the input connected to signal earth.

Test Point	Voltage	Test Point	Voltage
TR1 Base	0.8-	TR2 Emitter	0.6-
TR1 Emitter	1.4-	TR3 Base	0
TR1 Collector	10+	TR3 Collector	94+
R13-R16 Junction	10-	TR4 Collector	1.3+
TR2 Base	0		

7m Parts List.

Component.	Part No.
Complete Assembly	162.02
VR1 22Kohm Linear	237.04
VR2 200K + 200Kohm Linear CT	248.17
VR3 50K + 50Kohm Linear	248.19
VR4 25K + 25Kohm Linear	248.20
VR5 50K log + 50K reverse log	248.18
L1 10mH	403.30
Printed Circuit Board	450.40

8 RADIO SECTION

8a System Description:-

The major part of the Radio Section is mounted on the Tuner Module ((4)) and comprises:-

- (a) Tuner gang (4.2).
- (b) FM intermediate frequency amplifier and detector.
- (c) Stereo decoder.
- (d) AM mixer oscillator.

The ferrite rod aerial (4.3.) is mounted on the side rail adjacent to the module and the wave change switch (1.5) on the front panel. The external aerial input sockets (2.5 and 2.6) are mounted on the back panel and the power supplies are taken from the amplifier module, or in the case of a tuner from a separate power supply.

The function switches (4 way switch bank 1.9) "mono" "quasistereo" "afc" and "mute" are mounted on the front panel together with the variable mute level potentiometer (1.8) and stereo light (1.7).

8b Tuner Gang (Part No. 173.04)

The Tuner Gang is a self contained module. It is not recommended that servicing be carried out on the internal circuitry. Replacement tuners can be obtained from:-

The Service Department, Rank Radio International - or their authorised importers.

8 RADIO SECTION

8a System Description

8b Tuner Gang

Component	Values
R1	470 ohms
R2	10 K ohms
R3	10 K ohms
R4	10 K ohms
R5	10 K ohms
R6	10 K ohms
R7	10 K ohms
R8	10 K ohms
C1	.47 uF
C2	.01 uF
C3	3300 pf
L1	1 uH

Component Ref:	Part No's
1.4	483.43
1.5	520.11
1.7	482.16
1.8	258.01
1.9	523.26
1.10	523.16
1.10.1	190.03
2.5.1	537.06
2.5.2	537.05
2.6	537.00
4	190.15
4.1	171.05
4.2	173.04
4.3	416.01

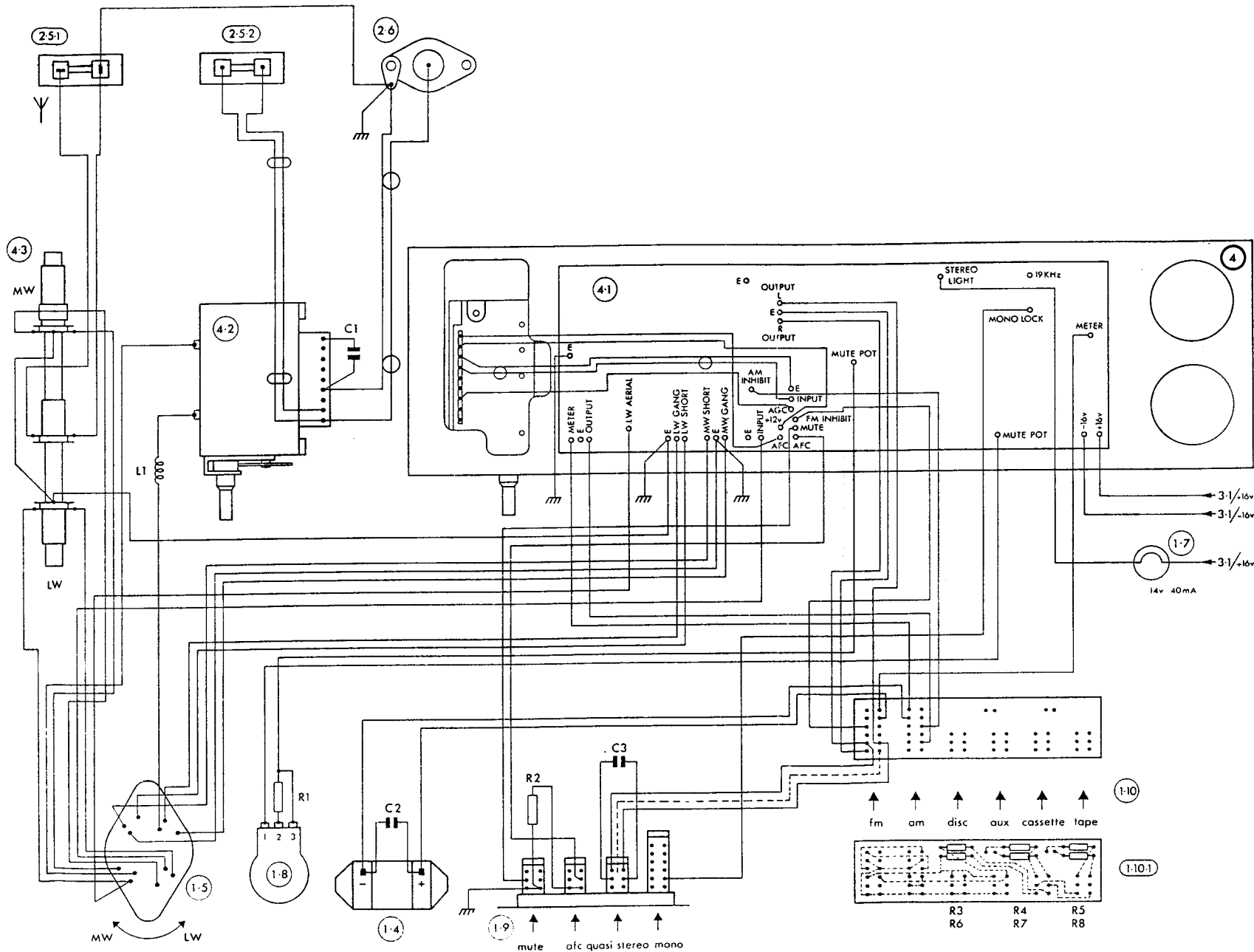

8d FM Section

IF Amplifier and Decoder Circuit Description

The 10.7 MHz IF signal from the Tuner Gang is coupled to X1, a 10.7 MHz ceramic block filter. From X1, (terminated by R1) the signal enters IC1 at pin 1. This integrated circuit with its associated external circuitry performs the functions of IF amplifier, limiter, AGC detector, signal strength detector, FM detector, mute detector and audio mute circuit.

IC1 pin 15:-

provides an AGC control voltage which after level shifting by R2, R6, starts at 0vDC with no signal and goes negative as the signal reaches about 1mV R. F.

IC1 pin 12:-

'Squelch' detector output, remains at approximately 0vDC when a signal is present, but rises to 4.5 volts under no signal conditions.

IC1 pin 13:-

provides an output voltage which rises with signal strength. This is applied via the variable mute pot. to the base of TR1. TR1 remains off until the signal strength, and thus the voltage on pin 13 is sufficient (depending on mute pot. setting) to cause TR1 to conduct.

IC1 pin 5:-

The audio output (at pin 6) is muted when a voltage is applied to pin 5 either from pin 12 via R5 and R4 or from TR1 collector via R7. Mute disabling is achieved by earthing pin 5 via function switch "mute".

IC1 pins 8, 9, 10:-

The 10.7 MHz IF from pin 8 is coupled to pin 9 (FM quadrature detector input) via the phase shift network L2, L3, C6, R3 providing a phase shift proportional to frequency deviation.

IC1 pin 6:-

The audio signal from the detector is coupled to pin 6 via the internal mute control circuitry.

TR2 serves the dual purpose of emitter follower for the audio drive to the stereo decoder, and phase inverter/DC amplifier for the AFC and tuning meter circuit. VR1 serves to set zero DC on the AFC and meter at centre tune. TR3 is switched on from the output of IC1 pin 12 when no signal is present and serves to centre the tuning meter in spite of any off-set voltage appearing on IC1 pin 6 during mute operation or off-tune.

The AFC disabling is achieved by earthing the AFC voltage fed to the tuner, via function switch "afc".

Disabling of the complete IF amplifier to prevent interference on AM radio is achieved by earthing IC1 pin 2 via D1 on all input selections except FM.

8d FM Section (Contd)

Stereo Decoder

The composite stereo multiplex signal from the TR2 emitter is coupled to the 'phase lock loop' stereo decoder IC2 pin 2 via an 'M derived' low pass filter comprising C10, R16, VR2, C12, C14 and L4. This filter is substantially flat and phase linear to 53kHz and combines a high attenuation 'notch' at 114kHz with a 6db per octave roll off, which minimises interference from adjacent channels. The response of the filter at around 38kHz can be controlled by VR2 to give a small amount of 'boost' or 'cut' this being used to set the stereo separation accurately. The integrated circuit contains an input buffer, a 76kHz oscillator with divider chain producing 38kHz and two 19kHz signals in quadrature, a phase lock 19kHz detector and DC amplifier to control the oscillator, a 19kHz pilot tone detector and lamp driver and a 38kHz stereo switching detector.

IC2 Pins 3 and 11 :-

The amplified composite audio signal from pin 3 is fed via C21 to pin 11 which is the input for both 19kHz detectors, C18 provides phaseshift compensation for the delays in the frequency dividers.

IC2 Pins 12 and 13 :-

give access to the 19kHz phase-lock detector output for filtering (C15, C17 and R20).

IC2 Pins 9 and 8 :-

give access to the pilot tone detector for filtering (C20).

IC2 Pin 6 :-

drives the stereo light.

IC2 Pin 14 :-

is the oscillator pin with C16 and VR3, R19 being the timing components. Earthing of Pin 14 via D2 disables the oscillator on all input selections except FM, preventing interference on AM radio.

IC2 Pins 4 and 5 :-

are the output pins (4 L.H. Channel, 5 R.H. Channel). The de-emphasis is provided by C19 in conjunction with R22, R23 and R24. TR4 provides gain (and power supply ripple rejection) and the correct impedance (4.3K, R26) for the 19kHz and 38kHz block filter X2. Component references are suffixed L for L.H. Channel, R for R.H. Channel.

Power Supply

Z1, R28 and TR5 provide an 11.3V positive supply rail with C47 providing a return path on the board for the power supply current which would otherwise return down the signal earth. Z2 and R30 provide a 12v negative supply rail for the AGC and AFC/meter shifting circuitry.

RADIO SECTION

8e FM Tuner Specification :-

Frequency Range	: 37.5 to 108MHz
Sensitivity for 30db signal/noise (IHFM method, 75 ohms)	: 1.6uV
Mono distortion at 1kHz	: 0.5% maximum
Stereo distortion at 1kHz	: 0.5%
Hum and Noise (Relative to 75kHz deviation, 1mV r.f. input)	: better than -65dB
Channel separation at 1kHz :	: 35 dB minimum
Channel separation at 10kHz	: 30 dB
Image rejection (IHFM)	: 60 dB
Alternate channel rejection (IHFM)	: 50 dB
AM rejection	: 50 dB
Capture ratio	: 1.5 dB
AFC ratio (IHFM)	: 3 to 1
Mute level range	: 2uV to 50mV
De-emphasis	: 50 micro-seconds
Frequency response (\pm 1.5dB).	: 40Hz to 14kHz
19 and 38kHz rejection	: 60 dB
Pilot sensitivity	: 5% modulation
SCA rejection	: 70 dB
Quasi stereo :-	
Separation at 1kHz	: 20 dB
Separation at 10kHz	: 4 dB

8 RADIO SECTION

8f FM Tuner Alignment Procedure.

Control Settings :-

$\frac{1}{2}$ Volume / Tone Controls flat / FM selected

'mute' out/'afc' out/ 'quasi stereo' out/ mono out

Low Distortion FM Generator required for Steps 1 - 5

Low Distortion Stereo Generator required for Steps 6 - 12

Test Point for Steps 1 - 10 At L. Speaker Output.

Test Point for Step 11 at R. Speaker Output.

Step	Generator Frequency	Modulation	R. F. Level	Tune to :-	Adjust	Requirements
1	88	1kHz, FM 100%	100uv	88MHz	Tuner Gang-"LO"	Correct tuning (Sinewave Output)
2	88	1kHz, FM 100%	100uv	88MHz	L3	Maximum Output
3	88	1kHz, FM 100%	100uv & then reduce	88MHz	Tuner Gang-"LO" "IF" "LA" & "LR"	Best Sinewave 30db S/N (IHFM) for 2uv or less
4	108	1kHz, FM 100%	100uv & then reduce	108MHz	Tuner Gang "TCA" & "TCR"	Best Sinewave 30db S/N (IHFM) for 2uv or less
5	Repeat 3 and 4 until both are satisfactory.					
6	100	1kHz, FM 100%	2uv	-	Tuning	Best Waveform Symmetry
7	100	1kHz, FM 100%	1mV	-	L3	Lowest Distortion 0.5% maximum
8	100	1kHz, FM 100%	1mV	-	VR1	Tuning Meter Central
9	100	9% Pilot R-L 1kHz	1mV	-	VR3	Max. Output Accuracy essential
10	100	9% Pilot R only 1kHz	1mV	-	VR2	Output 35dB below that in Step 9
11	100	9% Pilot L only 1kHz	1mV	-	VR2	Output 35dB below that in Step 9
12	Repeat 10 and 11 until both are satisfactory.					

8g Test Point Voltage Chart

Test Conditions

FM tuner tuned to FM generator modulated $\pm 75\text{kHz}$ with 1kHz sinewave, function switch "mute" depressed, mute potentiometer turned fully anti-clockwise.

All measurements taken with respect to earth potential using an Avo Model 8 or equivalent. The voltages shown in the chart are nominal values intended as a guide to faultfinding.

1. D. C. Voltages

IC1 Pin No.	1	2	3	4	5	6	7	8	9	10	11	12	13	14	15	16
Voltage	1.8	1.8	1.8	0	0	5.5	5.3	5.3	5.3	5.3	11.3	0.1	0	0	0.5	0
				to 2								to 4.5 5.6		to 4.5		
See note,				1	2							3	4		5	

- Note 1 Ov for signals above $10\mu\text{v}$ 2v with no signal
 Note 2 Varies with tuning
 Note 3 4.5 with no signal 0.1v for signal above $10\mu\text{v}$
 Note 4 Rises with increasing signal
 Note 5 Falls with increasing signal above $100\mu\text{v}$

AGC voltage on pin 7 of tuner gang. Ov for no signal, -2.8v for 100mV signal.

- TR2 Collector Ov to 0.6v depending on signal strength and mute potentiometer setting.
 TR3 Collector 6v to 0v .
 TR3 Base -0.3v on tune. $+0.6\text{v}$ no signal.

IC2 Pin No.	1	2	3	4	5	6	7	8	9	10	11	12	13	14
Voltage	11.3	3	5.3	7	7	16 mono	0	2.4	2.4	1.7	2.4	2.4	2.4	3.2
						1 stereo								

- TR4 Base 9.4V TR5 Base 12v Pin "STEREO LIGHT" at
 TR4 Emitter 10v TR5 Emitter 11.3v P.C.B. with lamp connected-
 TR4 Collector 3.9v TR5 Collector 14v 16v mono, 2.7v stereo.

2. A. C. Voltages

- TR2 Emitter 370mV rms 1kHz sinewave

IC2 Pin No.	2	3	8,9	11	12,13	10	14
rms Voltage	340mV	830mV	260mV	720mV	80mV	-	-
Frequency	1kHz	1kHz	1kHz	1kHz	1kHz	19kHz	76kHz
P-P square wave						3.4v	
P-P saw tooth							4v

- TR4 Emitter 200mV rms 1kHz .
 TR4 Collector (audio output) 520mV rms 1kHz .

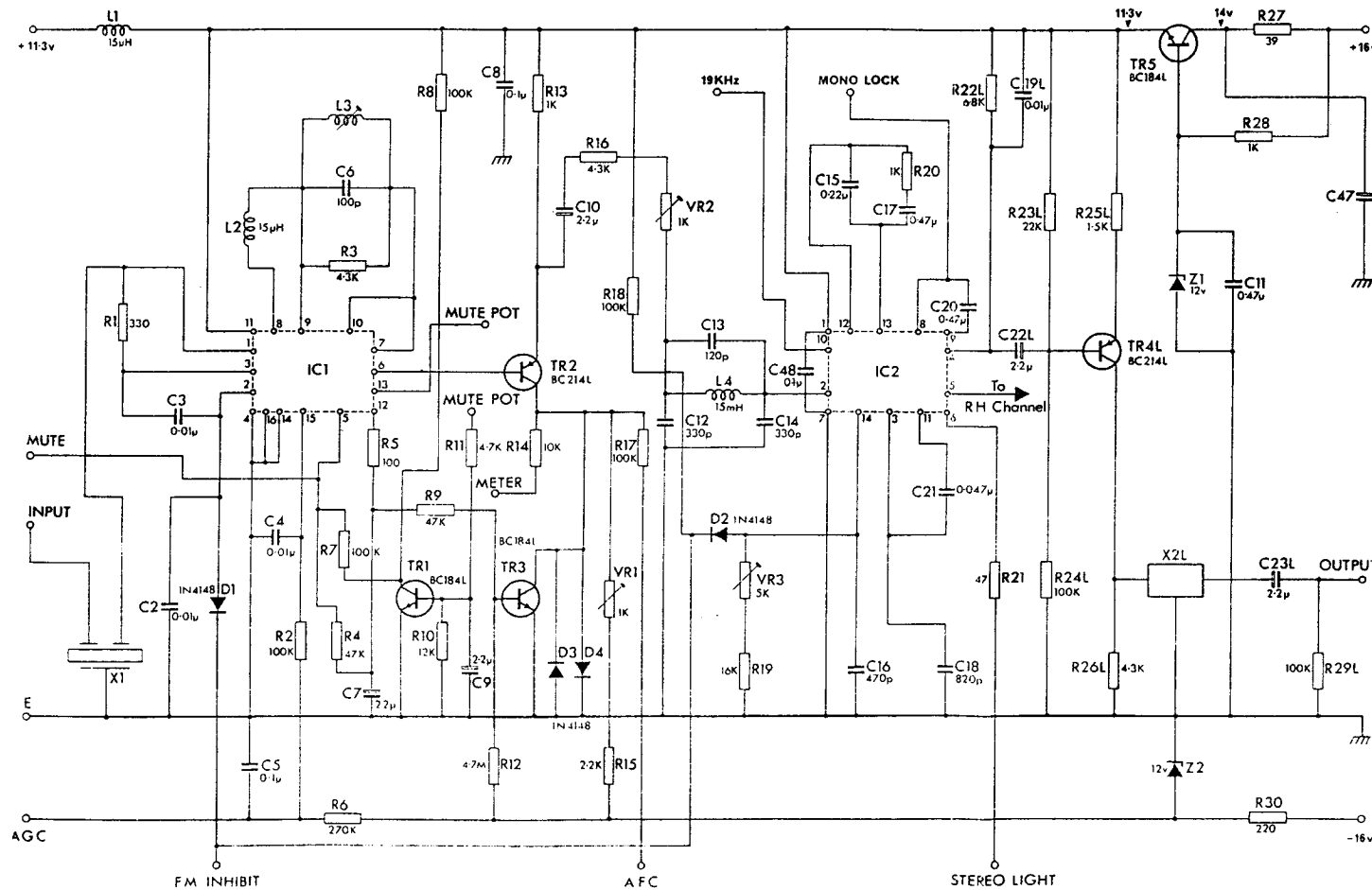

8h Parts List

Components	Part No.
X1, 10.7MHz Filter	375.01
L1, L2, 15uH	401.04
Tuner Gang	173.04
L3, IF Detector Coil	403.28
IC1, IF Amplifier	507.04
L4, 15mH	403.26
IC2, Decoder	507.05
X2, 19-38kHz Filter	375.02
Complete Assembly	190.15

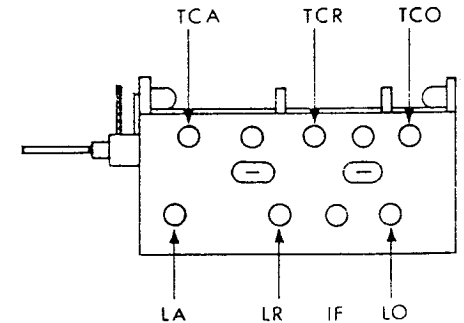

TUNER GANG 4:2

8 RADIO SECTION

8j A. M. Section Circuit Description

AM. Tuner

The R. F. signal is picked up by the ferrite rod aerial which is tuned by CT1 the AM section of the tuner gang. A secondary winding couples this signal into the TR6 base. The appropriate MW or LW coils are selected by the wave change switch, SW1. TR6 is a conventional self-oscillating mixer with separate oscillator coils for medium and long wave. The oscillator is tuned by CT2, a second AM section of the tuner gang. The main winding of the unused coil is shorted out by the wave change switch.

The IF signal (470kHz approx) passes from TR6 via a double tuned transformer T1 to TR7. TR7 amplifies the IF signal and feeds the ceramic filter X3 which (with C38) provides the main selectivity. X3 feeds TR8 which again amplifies the signal and drives the detector D3 via a fixed tuned transformer T4. The detector D3 drives the tuning meter via R48, with R49 providing a positive bias so that the centre zero tuning meter is held at the left of the scale until a signal is received. The negative output from the detector moves the meter progressively to the centre and then on a strong signal right across to the right hand side.

The negative detector output, after filtering by C43, L5 and C44, is coupled via R50 to the AGC time-constant network C42, R45 and then via R40 and T1 to the base of TR7 and R44 to the base of TR8 providing reverse AGC.

The audio output is taken via the isolating capacitor C46.

8k AM Tuner Specification

Frequency ranges :-

long wave	:	150 to 350kHz
medium wave	:	510 to 1650kHz
Sensitivity for 20dB signal/noise	:	20uV
Image rejection	:	40dB
I. F. rejection	:	40dB at 1MHz 30dB at 220kHz
Selectivity (IHF M)	:	25dB
AF bandwidth (-3dB)	:	3kHz

8l A. M. Section Alignment Procedure

AM Generator required set to 30% Modulation at 400Hz, RF level adjusted as necessary to prevent overload. Generator output coupled via 10K resistor to AM aerial input (2.5.1).

For all steps requirement is for maximum output at L. Speaker output.

Step	Generator Frequency KHz	Waveband	Tune to:-	Adjust :-
1	470	MW	350kHz	Both cores of T1.
2	550	MW	550kHz	T2 and then MW aerial rod.
3	1400	MW	1400kHz	CT2 and then CT1
4	Repeat 2 and 3 until no further improvement can be obtained			
5	150	LW	150kHz	T3 and then LW aerial rod
6	350	LW	350kHz	C34 and then C24
7	Repeat 5 and 6 until no further improvement can be obtained.			

8 RADIO SECTION

- 8j A.M. Section Circuit Description
- 8k A.M. Tuner Specification.
- 8l A.M. Section Alignment Procedure.
- 8m Test Point Voltage Chart.

All measurements taken with respect to earth potential using an Avo. Model 8 or equivalent. The voltages shown in the chart are nominal values intended as a guide to fault finding.

1. D. C. Voltages No Signal Strong Signal

TR6 Emitter	1.9	1.9
TR7 Emitter	0.4	0.2
TR7 Collector	4.8	6.2
TR8 Emitter	1.2	1.1
TR8 Collector	7.7	7.8
D3 Anode	0.1	-1.0
C42	0.6	0.3

2. A. C. Voltages
 Tuned to signal generator, modulated 30% with 400Hz signal at 1mV
 Audio Output 750mV rms

8n Parts List

Component	Part No.
Ferrite Rod Aerial	416.01
T1 IF Transformer	402.02
T2 MW. Osc. Coil	402.16
T3 LW. Osc. Coil	402.07
N3 470kHz Filter	355.00
T4 IF Transformer	402.04
L5 15mH	403.26

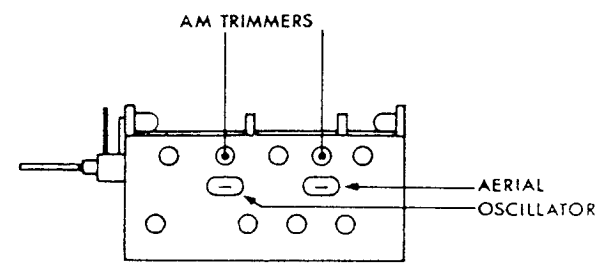
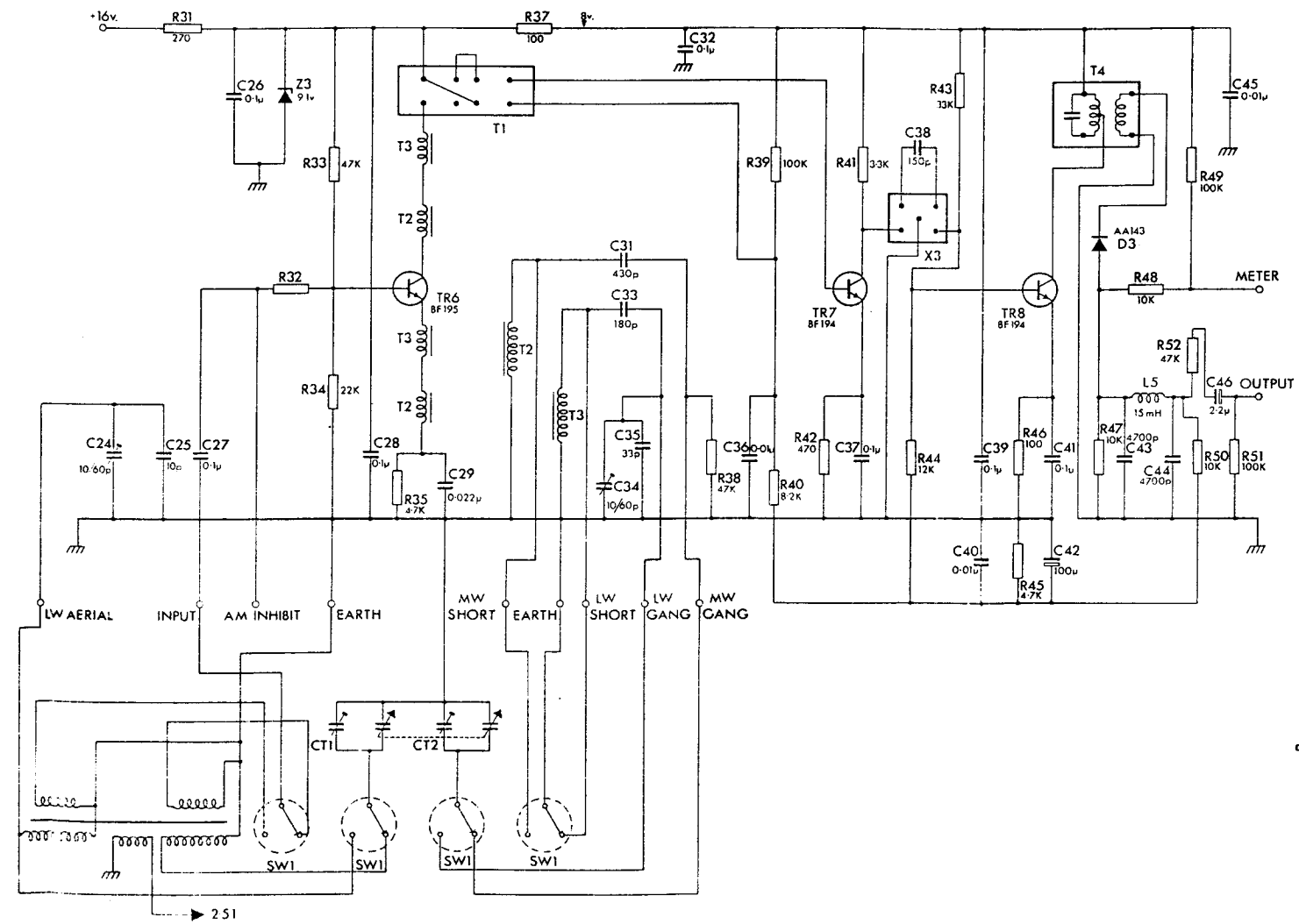

TUNER GANG 42

