

TL/12 PLUS POWER AMPLIFIER

INSTALLATION, OPERATION and MAINTENANCE

NOTES ON THE CHOICE AND PERFORMANCE OF LOUDSPEAKER SYSTEMS

* * *

The TL/12 Plus may be fed from Leak "Varislope III" and "Point One Plus" pre-amplifiers, or from any other suitable source. A source impedance higher than 25,000 ohms will tend to raise the hum level above the advertised figure of 85db below 12 watts. An input of 125mV r.m.s. will give a power output of 12 watts.

1. Check that all valves (tubes) are correctly seated in their holders and that the markings on the valves correspond with those on the chassis adjacent to the holders. The amplifier will work equally well with any of the alternative valves.
2. The amplifier should stand on its base in a well-ventilated position. If placed in a case or cabinet, ventilation must be provided. Four separate fixing feet with screws are provided with the amplifier.
3. On the British model the mains transformer is tapped for voltages of 205, 225 and 245 and the fused voltage selector plug on top of the mains transformer (see "Top Chassis" drawing) should be set appropriately. On the U.S. model the mains transformer is tapped for voltages of 105, 110 and 117 and the fused voltage selector plug should be set appropriately. The A.C. power supply should be connected to the two terminals nearest the guide key on the removable plug portion of the mains connector marked "A.C. Power."
In order that the amplifier may be remotely controlled we have provided two terminals marked "Switch" underneath the mains transformer (see "Under Chassis" drawing). The amplifier will not work unless these terminals are electrically joined, and when the amplifier leaves our factory a wire link joins the terminals. A remote switch may be run from the "Switch" terminals, after removing the link, the flex being passed through the adjacent grommet marked "Switch Cable." The flex should be knotted behind the grommet to avoid strain on the "Switch" terminals. Most users will wish to make use of the switch incorporated in the volume control of an associated Leak pre-amplifier, which is supplied with a plug and twin flex for this purpose. Full details are given in the installation sheets which accompany every pre-amplifier.
4. A double socket marked "A.C. Outlets" is fitted as a convenient source of power supply for gramophone motors, self-powered radio tuners, etc. The power taken from this socket should be limited to 100 watts or thereabouts. This socket is not controlled by the amplifier switch or fuse.
5. Many British tuner units have no built-in power supplies and require a source for heater and anode currents. The octal socket marked "Spare Supplies" on the back of the amplifier is provided for this purpose. The pins are numbered as indicated on the circuit diagram, and connections should be made to the pins similarly numbered on the removable plug which is supplied. The high tension supply is 350V and on some tuner units it may be necessary to provide a dropping resistor of suitable value, and some units may also require a condenser for smoothing and/or decoupling after the dropping resistor. An earth connection should not be made directly to the tuner unit, as this is automatically effected by the above connections via the power amplifier. The maximum current available from the 6.3V terminals is 2.1A and the maximum high tension current is 40mA.
6. A connection to earth (ground) should be taken from the third terminal on the removable plug portion of the "A.C. Power" connector. This terminal is the one furthest away from the guide key and its corresponding terminal on the fixed portion of the connector is marked on the chassis by the symbol \oplus . It is very bad practice to omit this connection, which may be made to the water system or to the steel conduit encasing the house wiring, providing that these systems themselves are properly grounded. No other earth connections should be made elsewhere, particularly when a pre-amplifier is also used, if freedom from "earth loops" and hum is to be obtained.
7. The loudspeaker should be connected by a *twisted* pair of wires to the terminals marked "Loudspeaker." It will be seen from the circuit drawing that one side of the loudspeaker winding is connected to the chassis, and no part of the loudspeaker wiring should be earthed elsewhere. The D.C. resistance of the connecting wires should be as low as possible, and not more than one-tenth the D.C. resistance of the loudspeaker. It is bad practice to operate any power amplifier without a loudspeaker, and if it is desired to mute the loudspeaker by switching it out of circuit this should be accomplished by use of a change-over switch which replaces it with a resistor of corresponding value and rating. The selector plug on top of the output transformer (see "Top Chassis" drawing) should be adjusted for the nearest match to the advertised impedance of the loudspeaker.

GENERAL NOTES ON MAINTENANCE

The circuit diagram provides a qualified engineer with all information required for servicing. However, the following points may be of interest:—

- a) The TL12 Plus does not depend upon the output valves (tubes) being a matched pair to give the stated performance, and if one output valve fails it is not necessary to replace both.
- b) Should it ever be necessary to replace the reservoir capacitor C14 (which is in the same can as C13) note that C14 must be of a type capable of handling a heavy ripple current. The C14 fitted has a very high margin of safety, being capable of handling 380mA. The values of 60mfd and 100mfd are made high for the sole purpose of minimising the hum resulting from the unavoidable "earth loop" which must be occasioned by the connection of non-powered tuner units.

NOTES ON LOUSPEAKER SYSTEMS

Space does not allow for detailed explanations on this vast subject, but the following points should be noted:—

- a) You *cannot* get high-fidelity results if you mount a loudspeaker in the same cabinet as the turntable and pickup.
- b) The assembly commonly called a "loudspeaker" consists of a magnet, a moving-coil, and a diaphragm (or "cone"). This assembly is a "motor". You do not listen to a motor; you listen to a *loudspeaker system*, which consists of one or more motors mounted in a *housing*, (baffle, box, cabinet, or horn). The housing plays a profound part in determining the quality of reproduction. The effects of various housings are discussed by L. L. Beranek in "Acoustics" McGraw-Hill Publishing Co., Ltd., 1st Edition.
- c) One good motor, properly housed, is capable of giving good results. Two good motors properly housed will give noticeably better results; in this case one motor is designed to reproduce bass, and the other, treble. A filter ("dividing network") must be used in conjunction with the two motors.
- d) The fundamental laws of acoustic propagation stipulate the impossibility of obtaining deep bass notes from small structures, whether they are musical instruments, foghorns or loudspeakers. If you want very good bass you must have a large loudspeaker system, i.e. 7 cubic feet or more.
- e) Remember that even the best modern loudspeakers are by far the weakest link (i.e. the greatest source of distortion) in a high-fidelity chain. The very best loudspeaker systems are relatively expensive and large. The fundamental weaknesses of modern loudspeakers are discussed succinctly in a paper by H. J. Leak, "High Fidelity Loudspeakers: The Performance of Moving Coil and Electrostatic Transducers", Journal of the British Institution of Radio Engineers, Vol. 16, No. 12, December, 1956. Copies are available from the Institution, 9 Bedford Square, London, W.C.1., price 7/-.

The above paper points out that even when a loudspeaker manufacturer publishes an accurate steady-state frequency response that this characteristic "is of little value in assessing the performance of a loudspeaker when it is the only measurement given".

The paper also states, "When one speaks of a loudspeaker having a certain degree of naturalness of reproduction one is assessing the subjective impressions derived from listening to it, and herein lies the difficulty of defining "high fidelity", for it is not often that any two people will agree entirely on the degree of naturalness or be capable of describing it in words. . . . These difficulties of agreement arise because all loudspeakers have known imperfections or distortions, and because the psychological attributes of hearing vary greatly between individuals. The tolerance or acceptance of distortions varies with individuals as regards the types, amounts and admixtures of the distortions". It is, therefore, impossible for us to tell you which is the "best" loudspeaker in any price range. You will have to listen to a selection and make your own judgment, which may not coincide with ours for the reasons given above.



HIGH FIDELITY
HOME MUSIC EQUIPMENT

TROUGH-LINE F.M. TUNER

SPECIFICATION

Frequency Range : 88 - 100 Mc/s.
Sensitivity : 2 microvolts at the aerial terminals for full limiting.
Aerial Impedance : 70.80 ohms, balanced with centre tap earthed.
Audio Output : Cathode follower output delivers approximately 1 volt and facilitates the use of long output leads with negligible high frequency attenuation.
A.C. Power : Self-powered. Consumption: 46 watts, 200/250 volts, 50-60 c/s.
Valves : 2 x EF80, 3 x ECF80, EB91, EM81, EZ80.
Lamps : 2 x Lilliput RV, 0-15A.
Dimensions : 10 1/2" x 7" x 7" deep (27.2 x 17.7 x 17.7 cms.).
Cut-Out : 10 1/2" x 6" (25.7 x 15.3 cms.).
Weight : 10 lbs. (4.536 kgs.).



This tuner is radically different from any other present-day F.M. receiver in its engineering design and circuitry: the oscillator employs a novel trough-line tuning inductor which, in conjunction with AFC, prevents frequency drift; the choice of 12.5 Mc/s for the intermediate frequency, in preference to the usual value of 10.7 Mc/s, prevents mutual interference between this tuner and any TV set in the same house; the high sensitivity of 2 microvolts at the aerial terminal for full limiting makes this tuner suitable for fringe area listening. The tuner is self-powered.

DYNAMIC PICKUP

This pickup results from five years continuous development of our first moving-coil design. Reports from users have justified our earlier belief that the pickup might earn recognition as the best in the world.



SPECIFICATION

THE ARM.

This is of advanced design having very low inertia. Friction is kept to a minimum by using a single pivot bearing. The arm is counter-weighted and has provision for plug-in interchangeable heads. An arm rest is provided.

GENERATING SYSTEM.

Dynamic (moving-coil). Coil impedance approximately 10 ohms, 1,000 c/s. No magnetic material is embodied in the moving parts, and the pickup is free from the inherent distortions of moving iron (magnetic variable reluctance) types. These distortions are also inherent in those dynamic pickups in which the moving-coil is wound on a magnetic core.

STYLUS.

Material: Diamond, guaranteed unconditionally not to chip or break.
 Stylus sizes: L.P. 0.001" radius + nothing -0.0001",
 78, 0.0025" radius ± 0.0001".

PLAYING WEIGHTS.

Between 3 and 4 grammes for L.P.
 Between 5 and 6 grammes for 78.
 Automatically adjusted by the weight of the head.

RECORD AND STYLUS WEAR.

These are lower than any pickup of which we have cognisance. Diamond has a playing life approximately 100 times longer than sapphire, and because it will take a higher polish than any other material it therefore causes less record wear.

FREQUENCY RESPONSE.

Total variation ± 1 db 20,000 c/s to 40 c/s with the L.P. head, including transformer. (Recorded velocity 1.2 cms/sec. r.m.s. above turnover).

Low frequency resonance:

20 c/s ± 5 c/s, with our lightweight arm.

High frequency resonance: (damped):

0.001" radius on Vinyl, 21,000 c/s ± 2,000 c/s.

0.0025" radius on shellac, above 27,000 c/s.

The frequency response does not change with temperature.

OUTPUT.

The shielded step-up transformer delivers an output of 8mV for each cm/sec. r.m.s. recorded velocity. This means that an amplifier with a sensitivity of 40mV at 1,000 c/s will be easily loaded by the pickup from commercial records.

TRANSFORMER.

The transformer has a step-up ratio of 1:80, and is heavily shielded in mu-metal. The primary lead is terminated in a plug and a shielded secondary lead is supplied. The secondary load impedance should be 100,000 ohms.

DIMENSIONS.

From the centre of the fixing stem to the front of the pickup head, 9 1/2". From the centre of the fixing stem to the rear of the arm, 2". The height of the pickup is adjustable and it can be used with any turntable.

H. J. LEAK & CO. LTD.

BRUNEL ROAD · WESTWAY FACTORY ESTATE · LONDON, W.3

Telephone:
SHEpherd's Bush 1173 (4 lines)

Telegrams:
Inland: Simusoidol, Edux, London
Foreign: Simusoidol, London

PRINTED IN ENGLAND BY WILLIAMS-SON LTD., LONDON, ENGLAND.

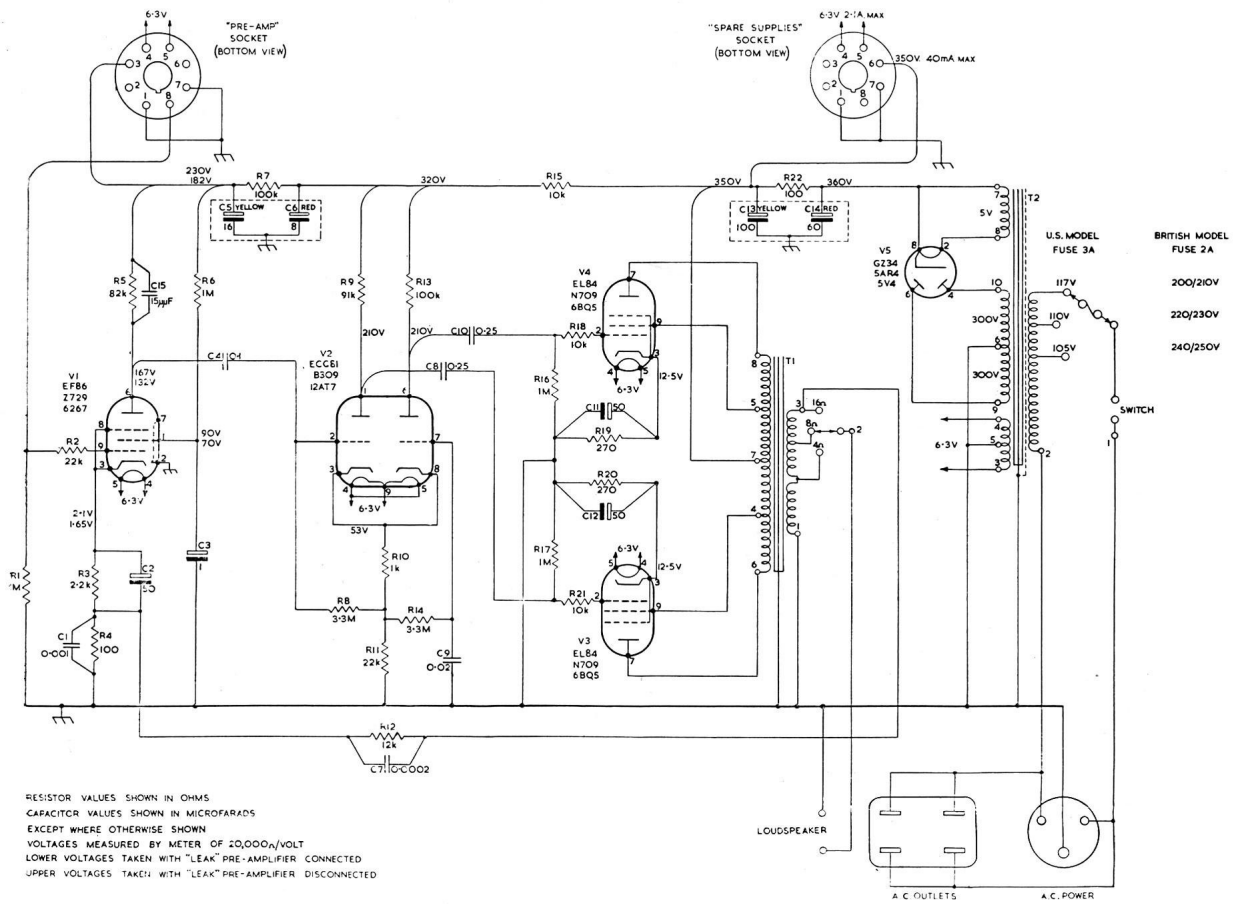

CIRCUIT DIAGRAM

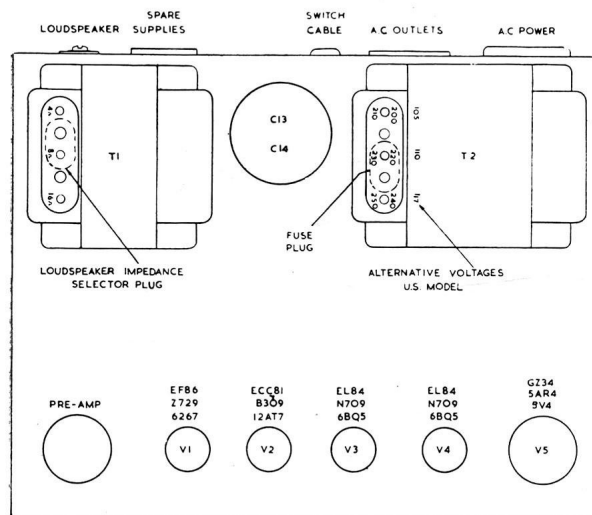

TOP CHASSIS VIEW

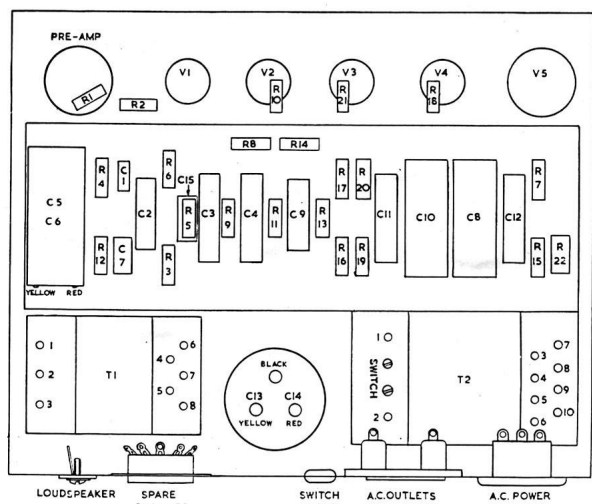

UNDER CHASSIS VIEW