

TM 15.2 ACTIVE

BI-AMPLIFIED DIGITALLY PROCESSED
LOUDSPEAKER SYSTEM

SERVICE MANUAL

Schematic Diagrams



CODE : 277322



Block Diagram & Wiring Connections	3
Power Supply Board, CONVY Processor Board, Display & Setting Board	4
Power Amplifier Board, Signal Input Controls & MIDI Interface Board	5
Mechanical Referements Parts List	6
Technical Specifications & Adjustments	7
Spare Part List	8

GENERALMUSIC S.p.a. Sales Division: 47842 S.Giovanni in Marignano (RN) ITALY - Via delle Rose, 12 - tel. 0541/957404 - fax 0541/957404 - <http://www.generalmusic.com>



Notice

Service must be carried out by qualified personnel only. Any tampering carried out by unqualified personnel during the guarantee period will forfeit the right to guarantee.

For a correct operation of the instrument, after having switched off, be careful to wait at least 3 seconds before switching on again. To improve the device's specifications, the schematic diagrams may be subject to change without prior notice.

Schematic Notes

All components marked by this symbol have special safety characteristics, when replacing any of these components use only manufacturer's specified parts.

The (μ) micro symbol of capacitance value is substituted by U. The (Ω) omega symbol of resistance value is substituted by E. The electrolytic capacitors are 25Vdc rated voltage unless otherwise specified. All resistors are 1/4W unless otherwise specified. All switches shown in the "OFF" position. All DC voltages measured to ground with a voltmeter 20KOhm/V.

- | | |
|---|-------------------------|
| ← Soldering point. | ↑ Supply voltage. |
| • Male connector. | ⊥ Logic supply ground. |
| ⊃ Female connector. | ⊕ Analog supply ground. |
| ⊔ M/F faston connector. | ↕ Signal ground. |
| □ Test point. | ≡ Chassis ground. |
| ⊔ Flag joined with one or more flags with the same signal name inscribed. | |



ATTENTION

Observe precautions when handling electrostatic sensitive devices



BLOCK DIAGRAM

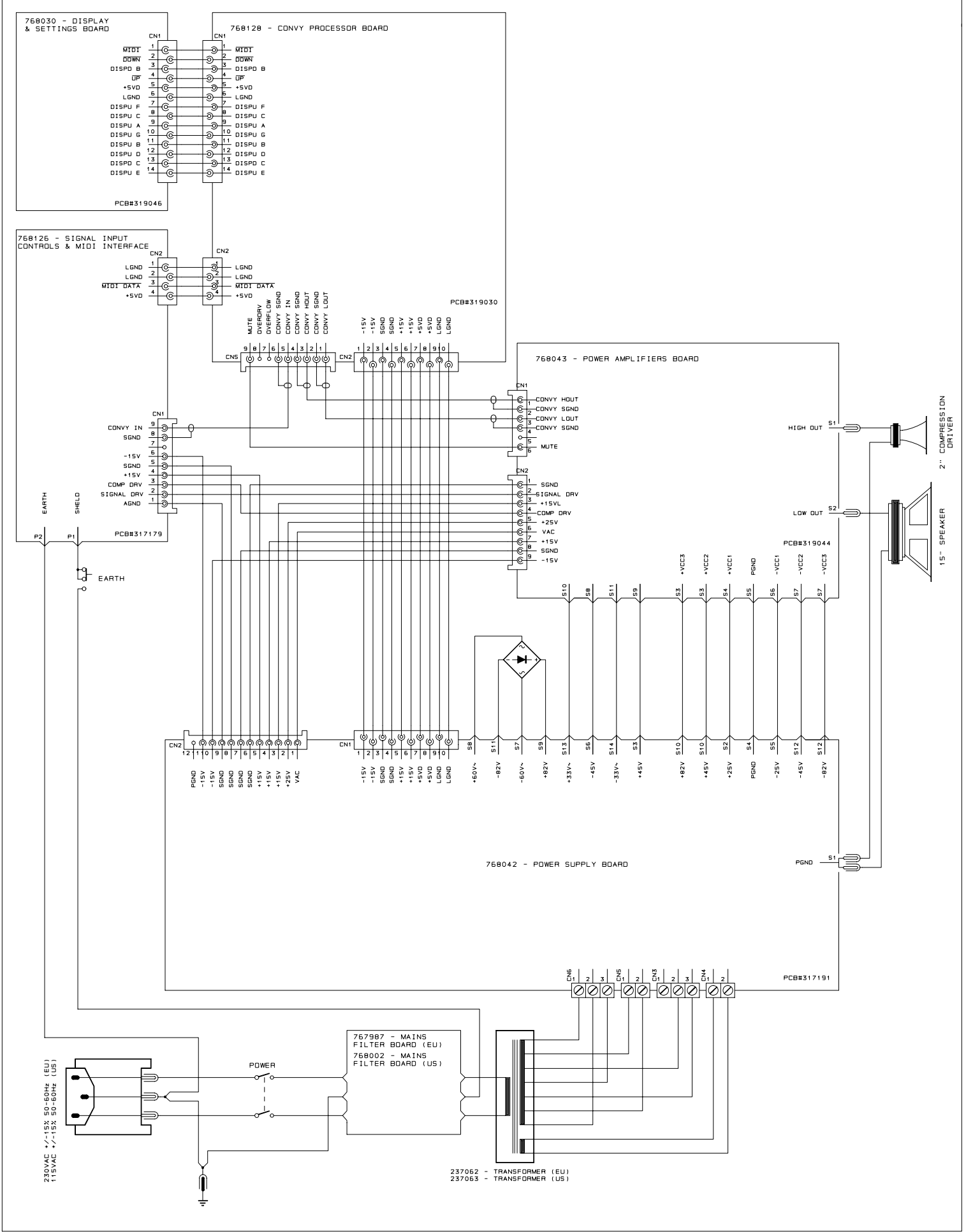
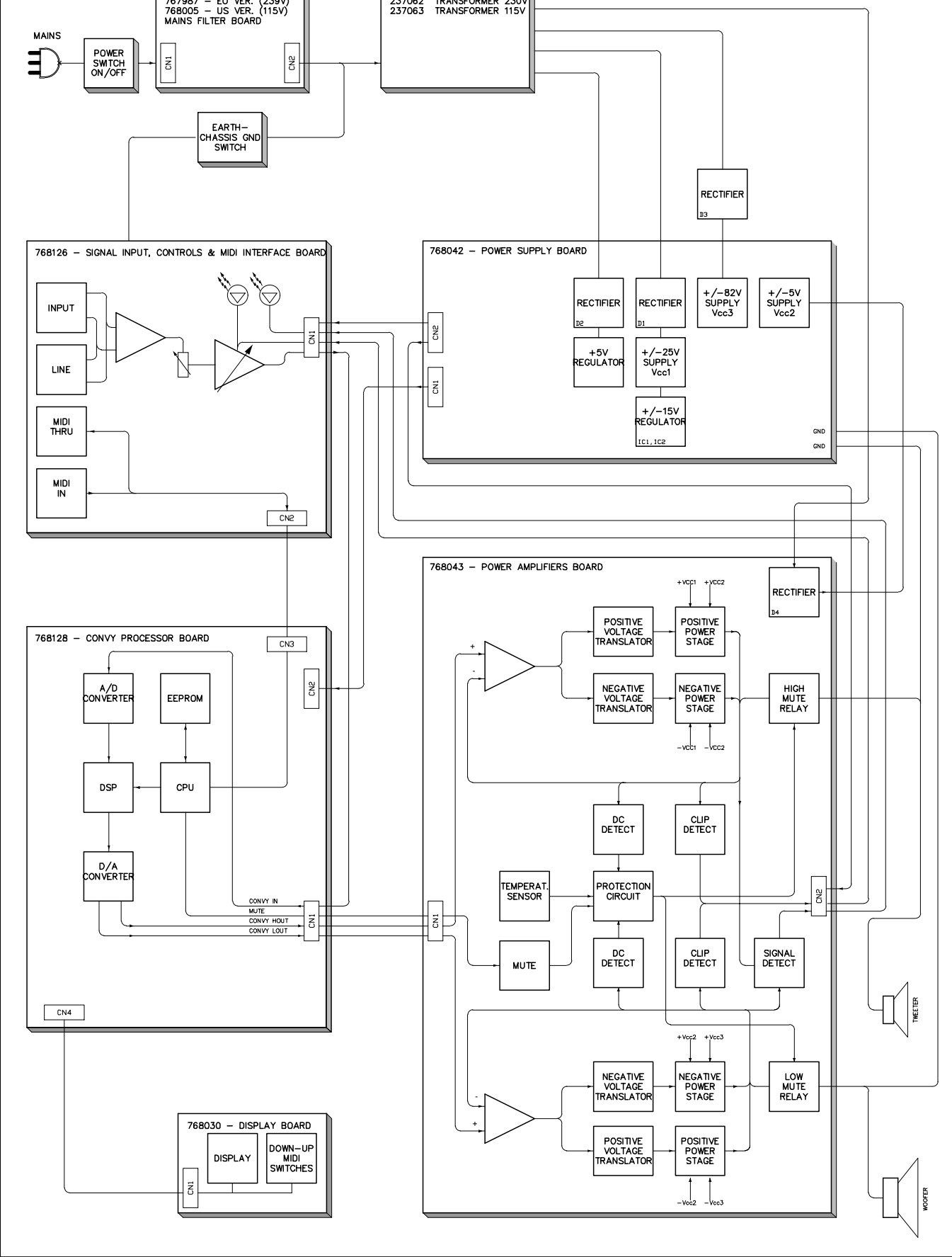

△237064 - TRANSFORMER ASSY (EU)
237065 - TRANSFORMER ASSY (US)

230VAC +/-15% 50-60Hz (EU)
115VAC +/-15% 50-60Hz (US)

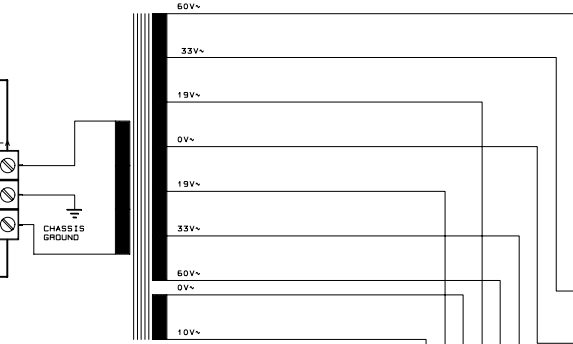
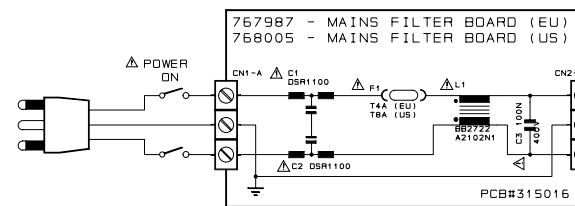

768042 - POWER SUPPLY BOARD

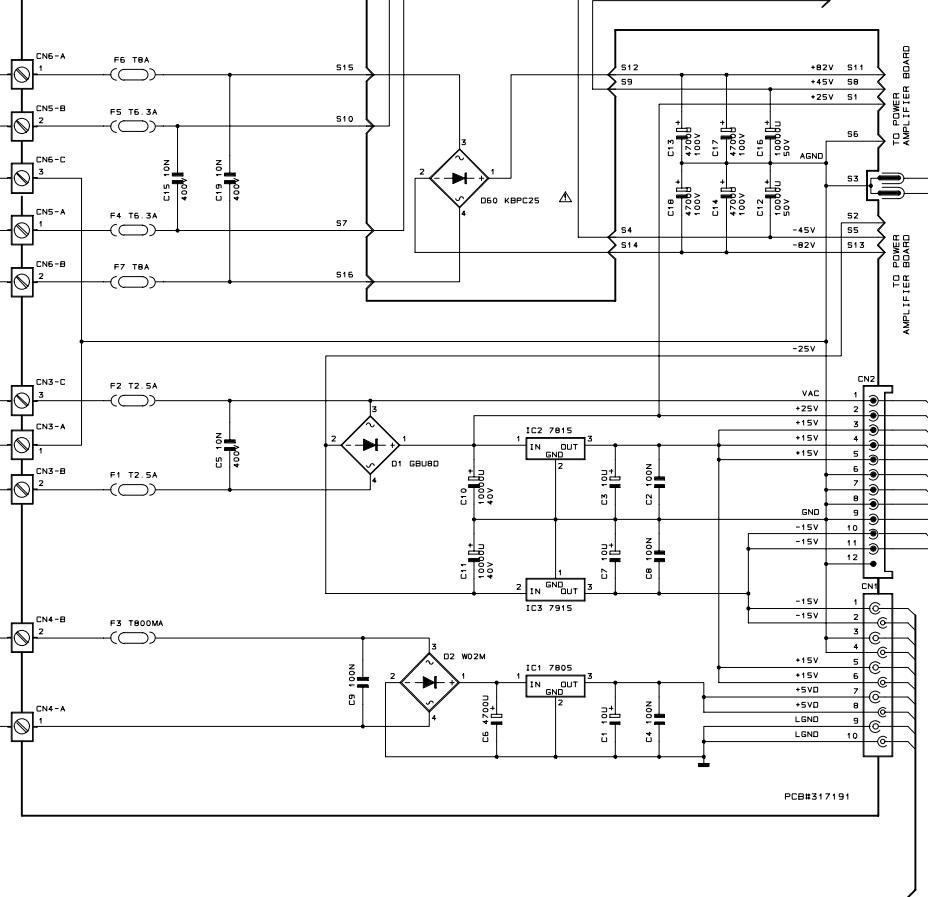

768128 - CONVY PROCESSOR BOARD

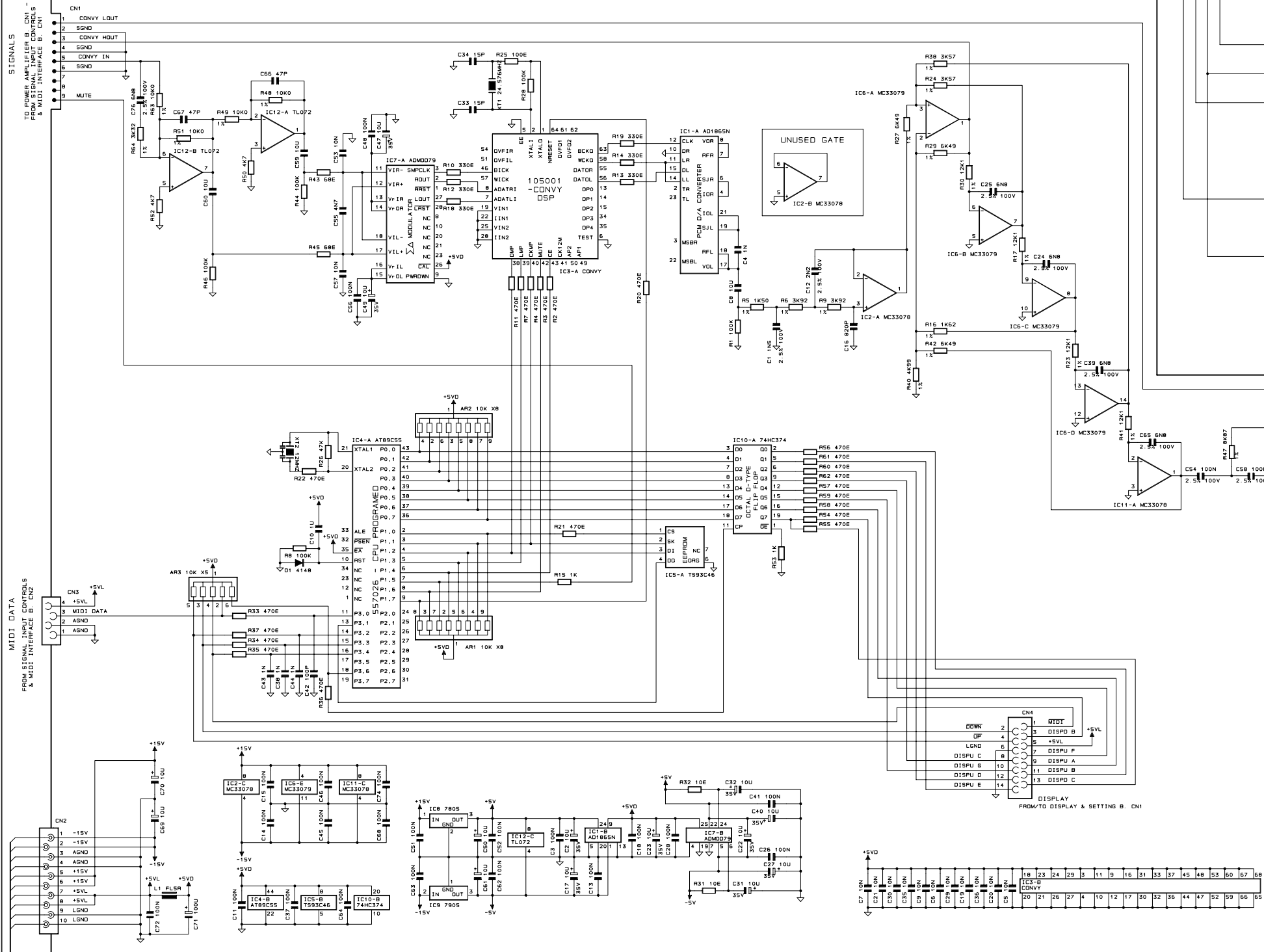

768030 - DISPLAY & SETTING BOARD

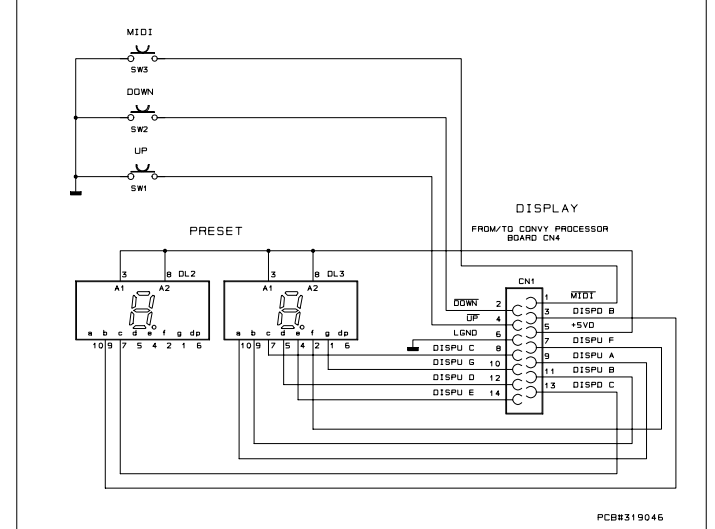

768043 - POWER AMPLIFIERS BOARD

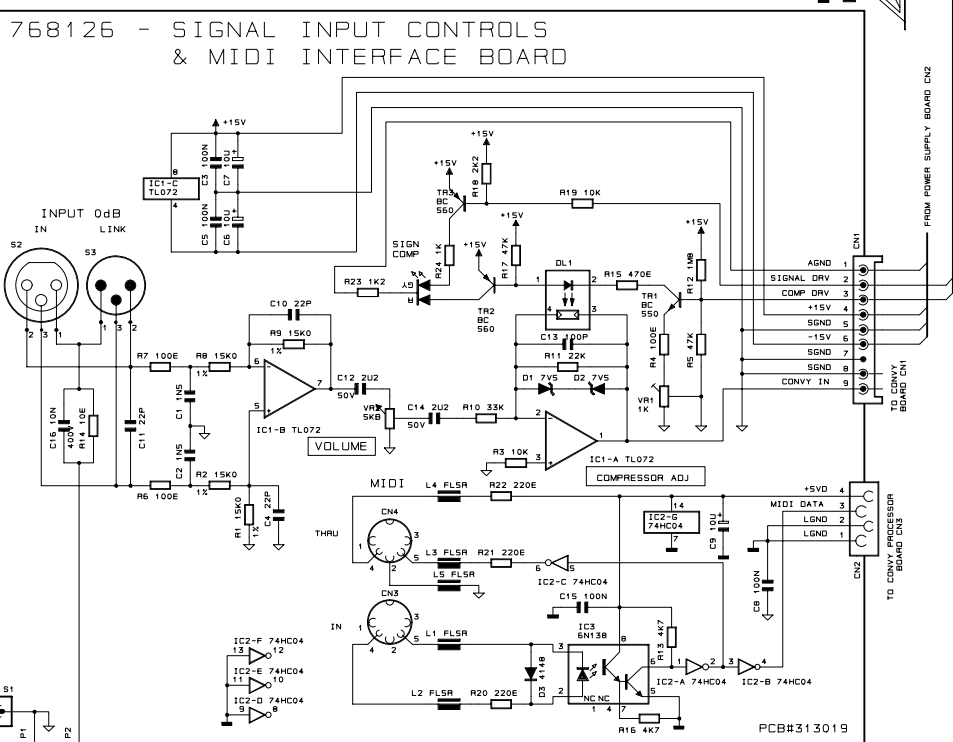
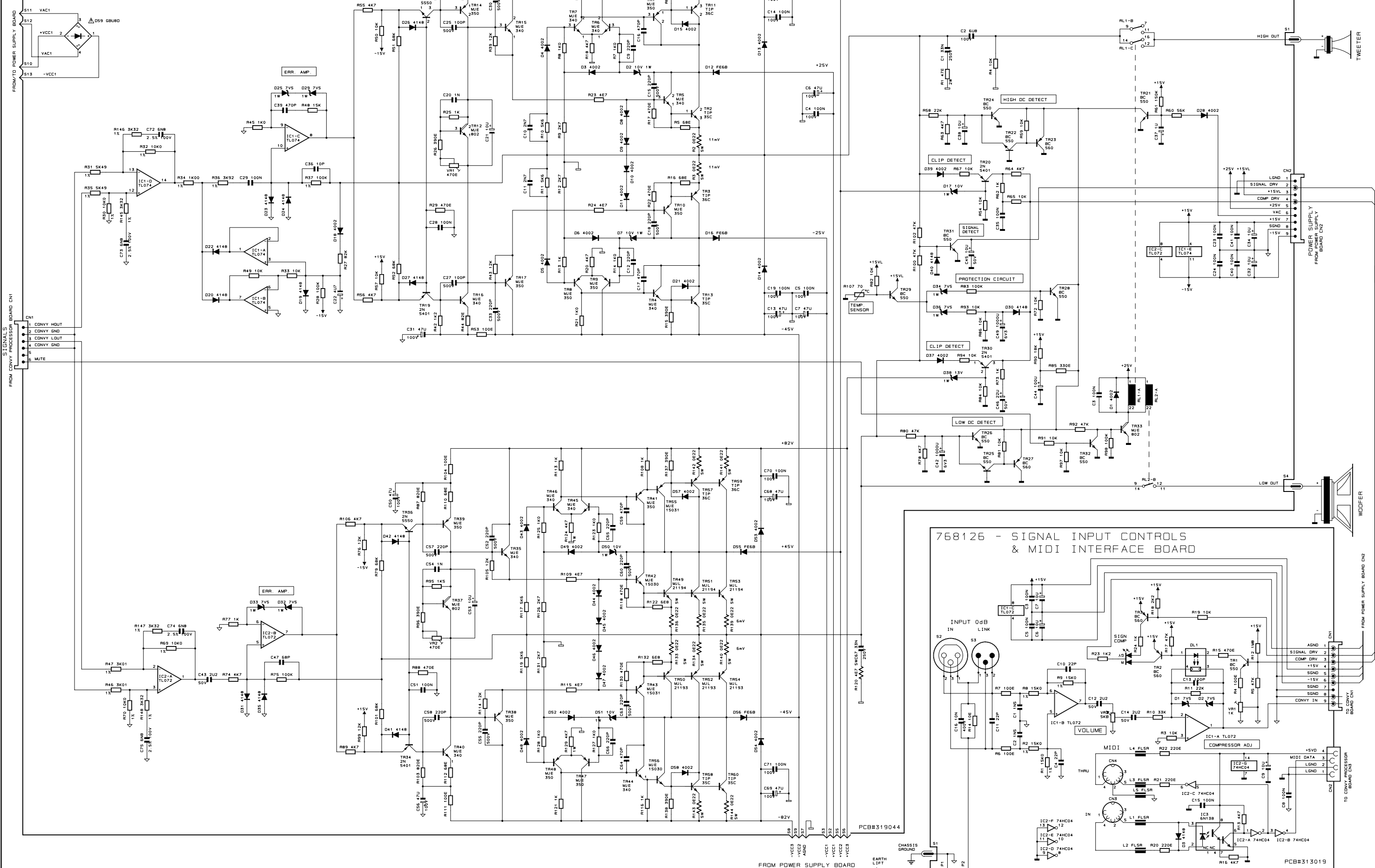

DRW. M. PALANGHI	DWG# 550549	PCB# 319044 - 313019	GENERALMUSIC S.p.A. ITALY
CKD I. BATTELLI	DSK# 46 PART. 1/1	SCHEMATIC DIAGRAM TM 15.2 ACTIVE	ALL RIGHTS ARE RESERVED. NO COPIES
APP. C. ZUCCATTI	REV. 28-04-97	POWER AMPLIFIERS & SUPPLY BOARD	OR REPRODUCE THIS DOCUMENT WITHOUT
		MAIN FILTER - INPUTS BOARD	WRITTEN CONSENT BY GENERALMUSIC.

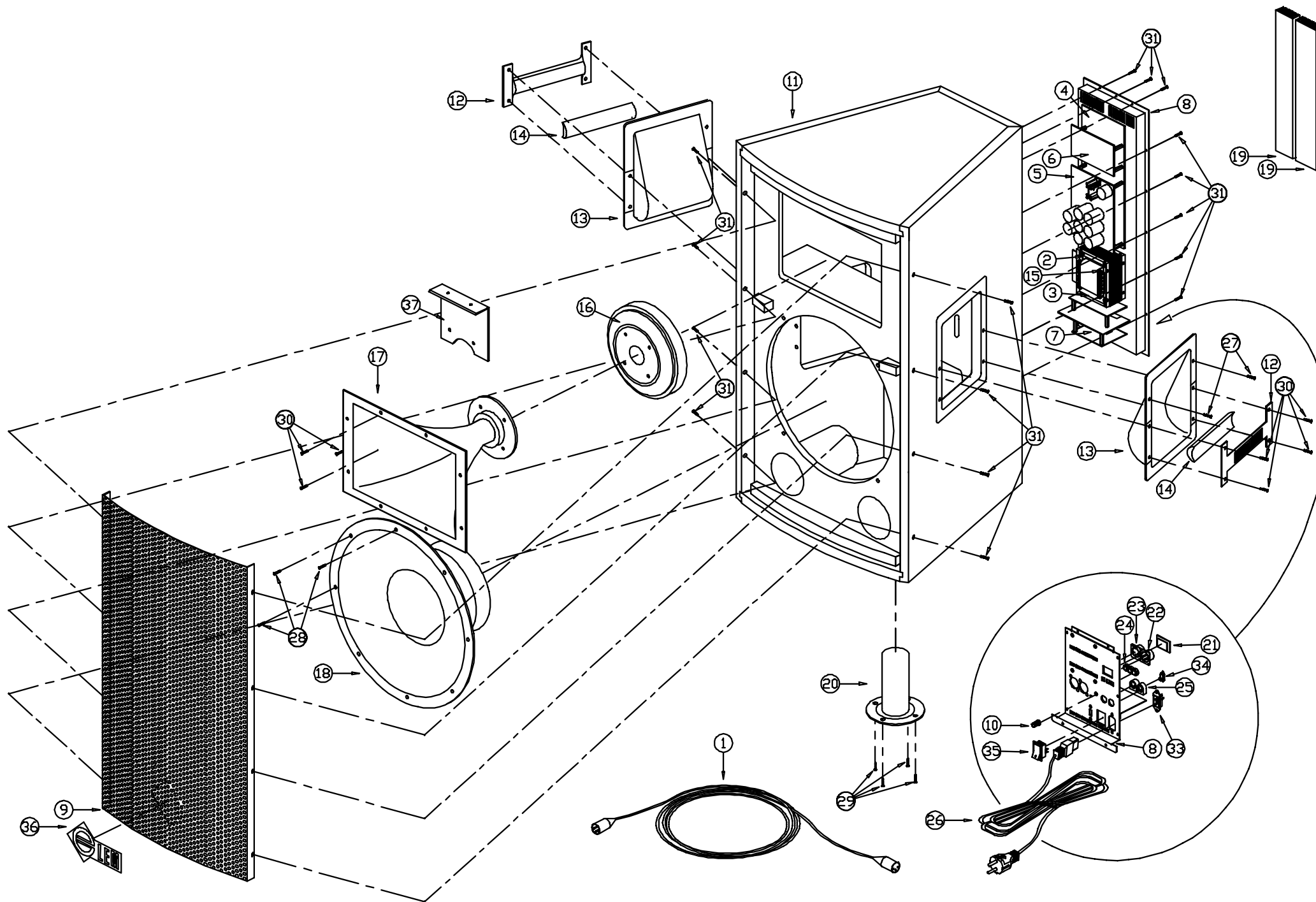

Spare Parts

1	887074	XLR MALE-FEMALE SIGNAL CABLE (mt. 1.5)
2	768030	DISPLAY & SETTING BOARD
3	768126	SIGNAL INPUTS CONTROLS & MIDI INTERFACE BOARD
4	768043	POWER AMPLIFIER BOARD
5	768042	POWER SUPPLY BOARD
6	768128	CONVY PROCESSOR BOARD
7	767987	MAINS FILTER BOARD (EU)
7	768002	MAINS FILTER BOARD (US)
8	667613	CONTROLS PANEL
9	667610	METAL GRID
10	659027	CYL. KNOB WHITE CAP
11	717054	WOODEN CABINET
12	347287	PLASTIC HANDLE
13	347286	HANDLE SET
14	347187	RUBBER HANDLE
15	237064	TRANSFORMER (EU)
15	237065	TRANSFORMER (US)
16	229030	2" COMPRESSION DRIVER TWEETER
17	347283	COMPRESSION DRIVER HORN
18	227038	15" SPEAKER
19	177476	AMPLIFIER HEAT SINK
20	177325	STAND ADAPTOR
21	150591	DISPLAY RED GLASS
22	141202	XLR MALE SOCKET
23	141184	XLR FEMALE SOCKET
24	140526	GRAY BUTTON
25	140212	DIN SOCKET
26	130297	MAINS CORD (EU)
26	130283	MAINS CORD (US)
27	120319	WL 4x15 MAINS CORD SCREW
28	120125	M5x35 MAINS CORD SCREW
29	120111	M6x25 MAINS CORD SCREW
30	120108	M5x30 MAINS CORD SCREW
31	120099	M4x25 MAINS CORD SCREW
32	120098	M4x20 MAINS CORD SCREW
33	110614	MAINS INLET (EU)(US)
34	110297	2 POLES 2 POS. SLIDE SWITCH
35	110291	MAIN SWITCH (EU)(US)
36	180637	ADHESIVE "GENERALMUSIC-LEM" BRAND
37	177474	DRIVER HOLDER

Inputs Controls Panel

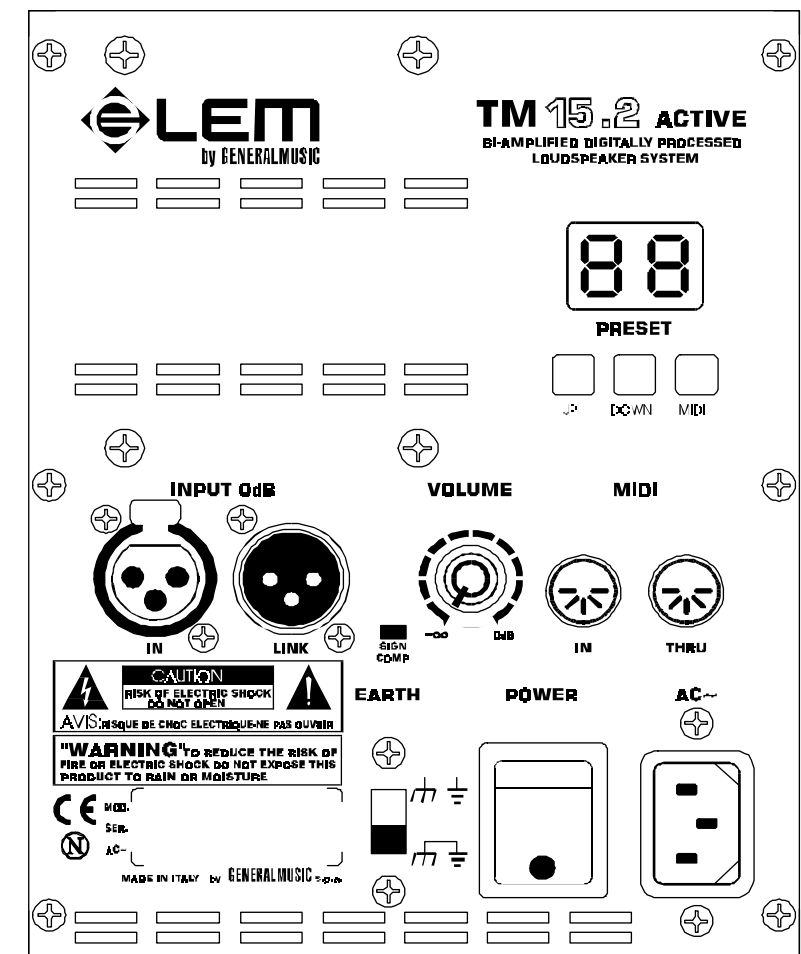

TOUR MASTER 15,2 ACTIVE - Technical Specification

SPEAKER SPECIFICATIONS

COMPONENTS	High		2" driver with controlled directivity horn
	Low		15" low frequency speaker
HIGH section POWER HANDLING (EIA RS-426A)		W continuous	75
		W peak	240
LOW section POWER HANDLING (EIA RS-426A)		W continuous	800
		W peak	2400
IMPEDANCE (nominal)	High	ohm	8
	Low		4
CONSTRUCTION			Cabinet: birch plywood Finish: Black scratch-resistant paint Protection grille: metal grille
WEIGHT		kg - lbs.	48,5 - 106,8
DIMENSIONS		mm - in.	470x790x465 (LxAxP) - 185x311x183(WxHxD)

PROCESSOR SPECIFICATIONS

INPUT	Sensitivity	dB	0 (0.775Vrms)
	Impedance	Kohm	30 (balanced) - 15 (unbalanced)
A/D converter		bit	18
D/A converter		bit	18
Dynamic range		dB	105
Sampling rate		KHz	48
CROSSOVER	Frequency	Hz	1350
	Slope	dB/oct.	24
HIGH section POWER AMPLIFIER		W continuous	150
LOW section POWER AMPLIFIER		W continuous	650
AMPLIFIERS DISTORTION		THD +Noise	<0,02%
CONTROLS			VOLUME control UP & DOWN selector buttons MIDI button Earth Lift
DISPLAY			2-digit display SIGN/COMP LED
CONNECTORS			1 XLR-F +1 XLR-M (input + link) MIDI in & MIDI THRU
POWER SUPPLY			230V ±15% 50/60Hz - 115V ±15% 50/60Hz

SYSTEM SPECIFICATIONS

FREQUENCY RESPONSE		Hz	50 ÷ 20000 (-10dB)
SENSITIVITY	SPL 1W/1m	dB	98
	MAX SPL continuous		127
DISPERSION ANGLE	horizontal	°	60 (±10)
	vertical		40 (±7)
DIRECTIVITY Factor (Q)			12
DIRECTIVITY Index Di		dB	11 (+2.8 , -4)

Note: the system specifications have been calculated using PRESET n.1 FLAT

BIAS ADJUSTMENT

Instruments, materials and tools:

- Audio Generator
- Dual Trace Oscilloscope
- Digital Voltmeter (or Multimeter)
- 4Ω 500W and 8Ω 100W Resistors
- Temperature Meter

Setup:

- Connect the Audio Generator to the input and set its output at 2KHz sinusoidal signal.
- Insert the temperature sensor through the interstize between the heatsink and R93 (PTC).
- Connect the 4Ω 500W resistor to the amplifier output instead of the woofer speaker and 8Ω 100W instead of tweeter speaker.
- Connect the oscilloscope probes (setting 20V/div., 1ms/div.) on the loads.
- Insert the voltmeter terminals on R107.

ADJUSTMENT PROCEDURE

- 1) Turn on the amplifier, pressing "UP" "DOWN" and "MIDI" simultaneously, check that the display shows "C".
- 2) Set the input signal to 0dB (0.775Vrms).
- 3) When the temperature has reaches about 45°C (109°F) set the signal input to minimum (0 or -∞).
- 4) Adjust the trimmer R111 to read a voltage of 6mV ±0.1 on the multimeter.
- 5) Check that the voltage across the R108 resistor has the same value.
- 6) At the same temperature condition, adjust the VR1 trimmer to read 2.2mV ±0.1 at R24 resistor.
- 7) Check that the voltage on the R25 resistor has the same value.

Verifying:

- 1) Increase the input level to obtain an output voltage about of 0.5Vpp.
- 2) Check with the oscilloscope that the output signal is without a cross-talk distortion and eventually slightly adjust the R111 or VR1 position until distortion disappears.
(Note: the voltage value across the R107 or R108 resistor must not exceed 10mV and the R24 or R25 resistor must not exceed 4mV).

LIMITER ADJUSTEMENT

- 1) Increase the input level to 10dB, adjust the trimmer VR1 until clipping distortion disappears.
- 2) Verify tha the led change colour from green to red.
- 3) Re-connect the speakers instead of the 4Ω and 8Ω resistors.

SPARE PARTS LIST

ACCESSORIES

887074	XLR Female-Male Signal Cable (1.5mt)
277310	Owner's Manual

ASSEMBLY

667613	Controls Panel
659027	Cyl. Knob White Cap
237064	Transformer (230V)
237065	Transformer (115V)
150591	Display Red Glass
110614	Mains Socket
110291	Power Switch
110037	T6.3A Fuse 6.3x32mm (US)
110035	T2.5A Fuse 6.3x32mm (US)
110034	T800mA Fuse 6.3x32mm (US)
110022	T8A Fuse 6.3x32mm (US)
110029	T4A Fuse 5x20mm (EU)
110023	T8A Fuse 5x20mm (EU)
110018	T6.3A Fuse 5x20mm (EU)
110015	T800mA Fuse 5x20mm (EU)
110014	T2.5A Fuse 5x20mm (EU)
667506	Left Side Bar
717054	Wooden Cabinet
667610	Metal Grid
347287	Plastic Handle
347286	Plastic Set
347283	2" Comprission Driver Horn
347187	Plastic Grip
229030	2" Compression Driver Tweeter
227038	15" Speaker
177474	Driver Holder
177325	Stand Adapter
130297	Mains Cord (EU Version)
130283	Mains Cord (US Version)

CONVY Processor Board

758128	CONVY Processor Board (PCB#313020)
230569	* FL5R200PNT EMI Coil For Signal
141059	* Con V M 9 C Mini Mate Burndy
141015	* Con V F 14c P=1.27 Mmatch Amp
141013	* Con V F 10c P=1.27 Mmatch Amp
141010	* 4 Contacts Vert Female Connector
100943	* MC33079 Quad Ln Op Amp
100919	* MC33078 Dual LN J-Fet Operational Amplifier
100737	* ADMOD79 2ch Ad Delta Modulator
100643	* AD1865N Dual 18bit Dac
100642	* TS93C46 1Kbit Eeprom Memory
100612	* 74HC374 Octal D-Type Flip-Flop
100061	* TL072 Dual J-Fet Operational Amplifier
100059	* 7805 +5V 1A Voltage Regulator
100058	* 7905 -5V 1A Voltage Regulator
080103	* 1N4148 100mA 75V Signal Diode
050494	* Resistor Array 10K X5 1/8w 5%
050492	* 10Kx8 1/8w 5% Resistor Array
010722	* 24.576MHz Quartz Resonator
010720	* 12MHz Ceramic Resonator With Capacitors
557026	* AT89C55-12JC Programmed CPU
105001	* CONVY Dsp Convolver

Power Supply Board

768042	Power Supply Board (PCB#317191)
141060	** Con V M 12c Mini Mate Burndy
141013	** Con V F 10c P=1.27 Mmatch Amp
140081	** H 2c P=10 Terminal Block
140069	** H 3c P=10mm Terminal Block
100060	** 7815 +15V 1A Voltage Regulator
100059	** 7805 +5V 1A Voltage Regulator
100049	** 7915 -15v 1a Voltage Regulator
080606	** GBU8D 8A Rectifier Diodes Bridge
080168	** W02M 1.5A Rectifier Diodes Bridge
030882	** 10000uF 50V Snap-In Electrolytic Capacitor
030881	** 10000uF 50V Snap-In Electrolytic Capacitor
030866	** 4700uF 100V Snap-In Electrolytic Capacitor
030858	** 4700uF 25V 20% Vert Electrolytic Capacitor
030560	** 4700uF 80V 20% Snap-In Electrolytic Capacitor

Signal Input Controls & MIDI Interface Board

768126	Signal Input, Controls & MIDI Interface Board (PCB#313019)
757942	* Photores Coupler
141202	* Hor. Male XLR Socket (M21bc Nuova Asme)
141184	* Hor. Male XLR Socket (NC3FPRH Neutrik)
141064	* 9 Contacts Hor. Male Connector

141010	* 4 Contacts Vert Female Connector
140212	* Horizontal Female 5 Poles Din Socket
100602	* 74HC04 Hex Inverter
100061	* TL072 Dual J-Fet Operational Amplifier
100035	* 6N138 Optocoupler
090194	* BC560 TO92 LN Pnp Transistor
090183	* BC550 To92 Ln Npn Transistor
080734	* Led 2.5x5mm Rect Diff Red-Grn LED
080245	* 7V5 1W 5% Zener Diode
080103	* 1N4148 100mA 75V Signal Diode
074570	* 5K lin. 31 clicks Potentiometer
070125	* 1K 20% Vertical Linear Trimmer
140526	* Gray Button

Display & Setting Board

768030	Display & Setting Board (PCB#319046)
141015	** Con V F 14c P=1.27 Mmatch Amp
140526	** Microswitch 100V 100ma 0.8mm
080717	** HDN1105 7 Segments Display

Mains Filter Board

767987	Mains Filter Board (Pcb#315016) (EU)
768002	Mains Filter Board (Pcb#315016) (US)
230565	** 2.5mH 250V 3A AC Line Filter
140010	** 3 Contacts P=10 Vert Terminal Block
110113	** Fuse Clip 5x20mm 6A max (EU)
110114	** Fuse Clip 6.3x32mm 10A Max (US)
020493	** 100n 250Vac MKP EMI Capacitor "Siemens"
010719	** 2n2 250Vac 7A 20% AC Line "Y" Filter "Murata"

Power Amplifier Assembly

727524	Power Amplifier Assenbly
768043	Power Amplifier Board (PCB#319044)
141059	** 9 Contacts Vert. Male Connector
141058	** 6 Contacts Vert. Male Connector
110316	** Relay 24V / 1 Switch no 16A 250V
110307	** Relay 24V / 2 Switch 5A 250V
100084	** TL074 Quad J-Fet Operational Amplifier
100061	** TL072 Dual J-Fet Operational Amplifier
090920	** Mje803 TO126 Npn Darl Transistor
090917	** MJE350 TO126 Pnp Transistor
090916	** MJE340 TO126 Npn Transistor
090201	** 2N5401 TO92 Pnp Transistor
090200	** 2N5550 TO92 Npn Transistor
090924	** MJL21194 NPN Transistor
090923	** MJL21193 PNP Transistor
090920	** MJE802P PNP Transistor
090919	** MJE15031 PNP Transistor
090918	** MJE15030 NPN Transistor
090917	** MJE350 PNP Transistor
090916	** MJE340 NPN Transistor
090863	** TIP36C PNP Transistor
090862	** TIP35C NPN Transistor
080282	** 13V 1W 5% Zener Diode
080261	** 10V1W 5% Zener Diode
080245	** 7V5 1W 5% Zener Diode
080241	** 5V6 1W 5% Zener Diode
080171	** FE6B 6A 100V Fast Recovery Diode
080156	** 1N4002 1A 100V Rectifier Diode
080103	** 1N4148 100mA 75V Signal Diode
070106	** 470E 20% Horizontal Linear Trimmer
070082	** 220E 20% Horizontal Linear Trimmer
080819	* PTC 70 Pth59f04bg222ts
080607	* KBPC25 25A 200V Bridge Rectifier Diode
080606	* GBU8D 8A Rectifier Diodes Bridge

Notes:

Each spare part is single quantity unless otherwise specified

Asterisk prefix explanation:

Omitted = First level spare part.

One asterisk = Second level, part of previous listed first level part.

Two asterisks = Third level, part of previous listed second level part.

Three asterisk =.....

Any request for not above mentioned part must encompass specific description including:

- 1) Model name,
- 2) Section,
- 3) Module code,
- 4) Reference name,
- 5) Quantity number.