

Lenco

Hi-Fi Record Player B 52

Description and Directions for Use

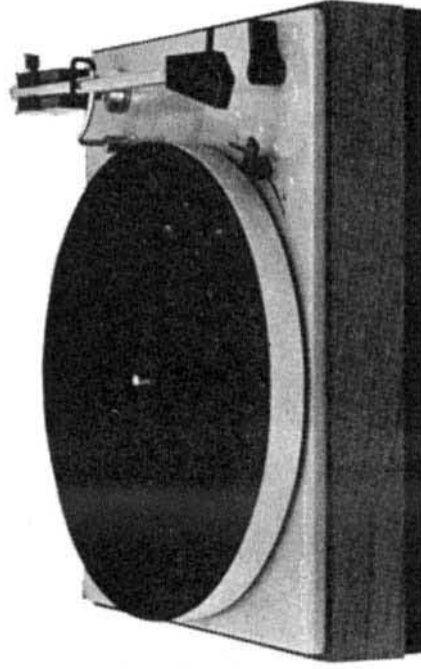

edge balance allows an amount of free vertical movement with the minimum amount of friction.

An adjustable sliding weight enables one to set the pressure weight exactly to suit the cartridge being used, as well as to balance the tonearm statically. Every B 52 is supplied with a centre piece for records with a large centre hole, a stroboscope disc for exact setting of the speed, a needle regulating gauge for setting the pick-up system, a set of shock mount supports and a build-in template (only required for chassis model).

Features

The Lenco B 52 record player is a precision unit of true Hi-Fi quality which will satisfy even the most demanding of music lovers.

The instrument can be used for stereo as well as monaural listening.

The speed can be set at the usual click-in stops of 16 $\frac{2}{3}$, 33 $\frac{1}{3}$, 45 and 78 rpm, and additionally can be adjusted continuously from 30 to 86 rpm.

The light tonearm of the B 52 is a first class feat of fine mechanical precision, and guarantees a clear, undistorted sound reproduction, with the greatest possible protection for your records. The tonearm is lowered onto the record by the operating a semi-automatic handswitch, which eliminates the possibility of records or needles being damaged whilst putting the tonearm onto the record.

The unit is SEV, DEMKO, NEMKO, SEMKO and CSA tested and approved.

Technical Description

The very silent 4-pole motor (20) is spring mounted onto a rigid sheet steel baseplate. The 2 mm thick, heavy sheet steel turntable rests on a conical shaped spindle which lies in an elongated bearing armature with steel bearings.

The power is transmitted from the conical axle to the turntable by the rubber covered idler wheel.

The change of speeds is brought about by moving the idler-wheel on the motor axle.

The miniature ball-bearings fitted into the tonearm allows for a free sideways movement, and the knife-

Unpacking the B 52

When unpacking check for possible damage. The B 52 is thoroughly checked and tested before leaving the factory. Any damage which may have been caused during transport should be reported immediately.

In this connection we would like to point out that the upper part of the knife-edge balance has been put into the lower part. i. e. it is held there only by the weight of the arm. The resulting movement which can be felt just above the armature when lifting the arm, is a normal and necessary feature of this type of armature and should not be mistaken for a fault or damage.

Preparation for Use

The B 52 is available on a wooden base, in a carrying case or as a build-in model. To avoid damage of the turntable armature during transportation, the turntable is separately packed in cardboard.

Models built into a carrying case or mounted on a wooden base are delivered fully assembled and can therefore be operated without any difficulty. The build-in model must be assembled on the spot, and the instructions on the build-in template should be carefully followed. On all models the spring-mounted driving motor (20) has been secured for transport. This has been done by means of two red marked securing screws (11) to be found on the baseplate under the turntable and these should be loosened until the motor is freely sprung. The B 52 is made to be connected to a 220 Volt current, 50 cycles, and cannot be changed. Models adjustable to voltages of 115, 145 and 225 Volts can be ordered. If you have an adjustable model it can be recognised by a black screw being present on the voltage selector plate (10). This screw should be screwed into the position showing the desired voltage on the selector.

To ensure perfect running important bearing and driving points should be cleaned if necessary before putting on the turntable. The important points are: Turntable spindle, underside of turntable, turntable armature and the rubber surface of the idler wheel (18). A clean, dry, non-fluffy cloth should be used for cleaning. Only if oil or grease spots are present should the cloth be sparingly sprinkled with methylated spirits or carbon tetrachloride. (Benzine must not be used.) The turntable is now put on and secured to the spindle with the clips, to be found in the accessories bag. The rubber mat is then put onto the turntable.

The counterweight (1) of the arm is pushed from the back onto the tonearm tube, and tightened temporarily by tightening knob (2).

Interchangeable Plug-in Heads

The B 52 is usually delivered with an empty plug-in head, so that each buyer may select his own pick-up system. To each model belongs an empty plug-in head (6) as well as parts to build-in the popular, internally standard cartridges. If various cartridges are selected (e. g. to play older 78 rpm shellac records), we suggest that a separate plug-in head is purchased for this cartridge, to make an easy change possible.

Assembling of the Cartridge into the Plug-in Head

(see diagram 2)

The cartridge is to be fitted into the plug-in head as follows:

1. The screws of the cover of the plug-in head should be loosened and the cover taken off.
2. Cartridge to be mounted onto the mounting plate with the assembly material provided.
3. The mounting plate with the mounted cartridge should be screwed into the plug-in head with the securing screws.
4. Plug-in head should be put onto the tonearm and secured by turning ring (5).
5. The cut-out slit in the needle setting gauge should be slipped over the armlever rest (3), and the turntable spindle pushed through the hole (A).
6. Withdraw the tonearm from the securing clip (4), push it towards the centre of the turntable and lay it gently on the cardboard. Slide the small mounting plate with the cartridge in the plug-in head, until the point of the needle is directly on the black line of the setting gauge, tighten the screw.
7. Remove plug-in head from tonearm and join to cable eyes.
 Left channel: L = white
 Right channel: R = red
 Left earth channel: GL = blue
 Right earth channel: GR = green
8. Replace the cover.
9. Put the plug-in head onto the tonearm again and secure with ring (5).

Mounting Material

- 2 screws 0.118 inches long
- 2 screws 0.314 inches long
- 2 screws 7.374 inches long
- 2 distance bushes 0.137 inches long
- 2 mounting screws
- 1 additional weight for crystal and ceramic cartridges
- 1 securing screw for additional weight

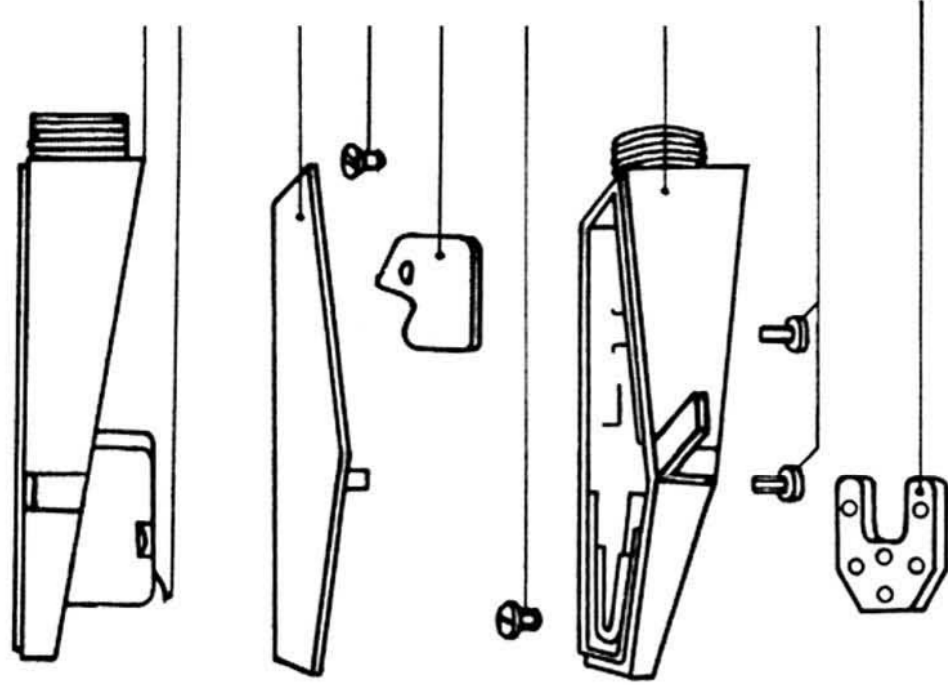

Cover

Securing screws for additional weight

Additional weight for very light cartridges

Securing screw for mounting plate

Bushes with silver plated contact terminals to secure plug-in head

Tightening screws for cover

Small sliding assembly plate.

diagram 2

To Set the Arm-lifting Apparatus

1. Place a record onto the turntable.
2. Move the tonearm gently by hand until the needle of the cartridge is just above the first groove of the record.
3. Turn the knob (7) slowly to the right to position «PLAY», until the needle is on the record.
4. The securing screw (13) of the arm rest (3) to be loosened and the arm rest to be moved so far up, until the distance between it and the rubber nipple on the tonearm is about 1 mm.
5. Arm rest to be held in this position and the securing screw (13) tightened (a coin may be used for this).

After completion of this adjustment the cartridge will lift from the record if the knob is turned to either position ON or OFF. In position ON the driving motor of the record player is switched on, and the turntable turns without the needle being on the record. In this position the tonearm can be guided to any desired position on the record without endangering it. If the knob is now turned slowly to position PLAY, the tonearm will lower gently onto the record.

This lowering device protects your valuable records and delicate needle from possible damage.

Regulating the Pressure

The pressure of the pick-up on the record is regulated by means of the counterweight (1) to be found at the back end of the tonearm.

1. Tonearm to be balanced by sliding the counterweight.
2. Counterweight to be pushed to the front until the prescribed pressure weight is set. The sliding from marking to marking makes a change of 1 gr. (approx.).
3. Counterweight to be tightened by turning securing screw (2).

An inexpensive and facilitating aid to control the pressure weight exactly is the Lenco tonearm scale.

Electrical connection

The shielded pick-up cable (16) is provided with a standard plug which can be connected to a loudspeaker or radio. This connection is indicated as «GRAMMO», «TA», «PICK-UP» or «Q» on the radio. Later models of amplifiers or radios of European origin have been fitted with a standard socket which fits the B 52. To connect to other or older models with different sockets a shielded intermediate cable should be used. When the unit has been connected to the electric current it is ready for use.

To Play the Records

1. Check if the plug-in head and the cartridge with the correct needle for the selected record has been properly plugged in, and if the securing ring has been well tightened.
2. Set the speed control lever to correspond with the speed required for the record, check that it is properly «clicked-in».

3. Place the tonearm onto the armrest so that the point of the needle lies directly above the first groove of the record.
4. Turn the handswitch to ON and wait a moment until the turntable has reached the correct speed.
5. Now slowly turn the handswitch to PLAY position.
6. When the record has finished playing, turn the switch to OFF. After the tonearm has been returned to its rest, the record may be changed.
7. If you have finished using the record player, we suggest that you secure the tonearm with the securing lever.
8. To play records with a large centre hole, use the adapter provided with your B 52.

Speed Control and Adjustment

The rpm's are carefully set and tested at the factory. If for any reason, re-adjustment is required, it should be done in the following way:

1. Slide the speed lever onto the desired speed.
2. Place a record onto the turntable.
3. Place the stroboscope disc provided onto the record (round, ringed black and white striped disc).
4. Push the tonearm into position, so that the point of the needle is directly above the first groove of the record.
5. Slowly turn the handswitch onto ON. Allow the player a few minutes to warm up.
6. The handswitch may now slowly be turned to PLAY.
7. Light the stroboscope disc with a naked electric bulb. The dark stripes in the circle marked for the speed being tested should appear to stand still if the speed is correct. If you observe a movement of the stripes, adjust the speed as follows.
 - a) Loosen the screw opposite the appropriate click-in stop. (One or two turns are quite sufficient.)
 - b) Place the speed lever in the groove and slide the lever slowly along until no forward or backward movement of the stroboscope disc can be observed.
 - c) Carefully lift the lever out of the groove, and without altering the position, tighten the screw.
 - d) Repeat this until all speeds are correct.

Maintenance

The bearing points which are to be found on the machine require no maintenance. To remove clinging dust or hairs, the point of the needle should be cleaned with a soft brush after each record.

N. B. To avoid damaging the pick-up system the direction of cleaning should always be from the back to the front of the cartridge.

At least once a year the needle should be microscopically checked by an expert. Worn or damaged needles result in a bad distorted sound reproduction and damage your valuable records.

A periodic check of the pressure weight with the Lenco tonearm scale is to be recommended.

Mounting the LENCOCLEAN

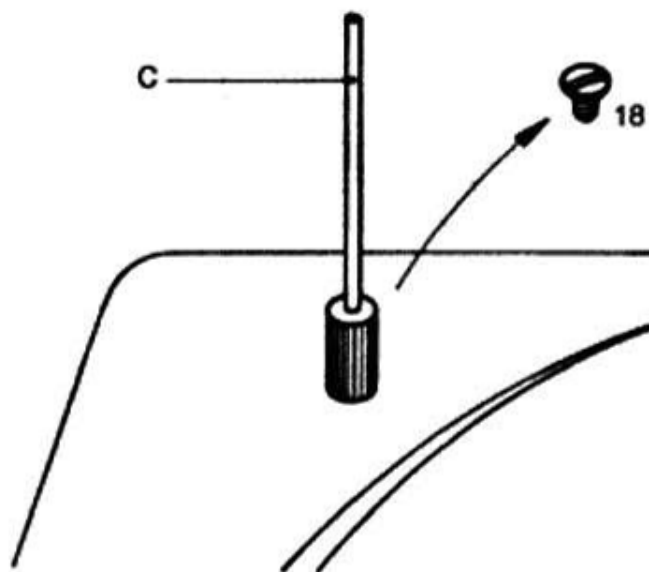

The LENCOCLEAN Record Cleaning System, which thoroughly cleans the records while they are being played, and not only reduces unwanted noise but also extends the life of your records, can easily be mounted on the B 52.

Remove the screw «A» in the far left-hand corner of the baseplate, and in its place screw the spindle «B». Remove the support from the pedestal supplied with the LENCOCLEAN and place it over the spindle «B», and the LENCOCLEAN can then be used directly on this.

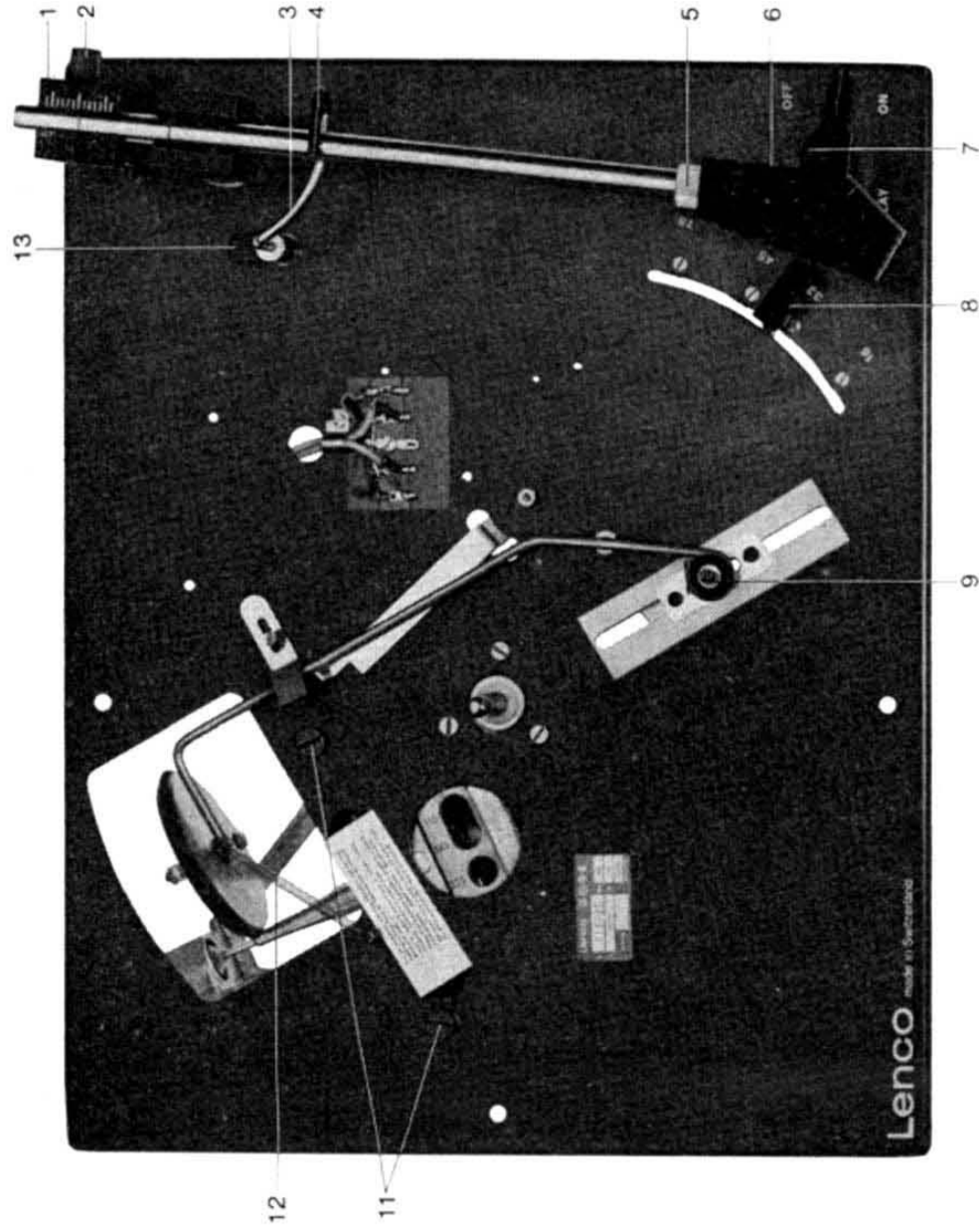

- 1 Gegengewicht
- 2 Befestigungsschraube für Gegengewicht
- 3 Armheber
- 4 Tonarmsicherungsklammer
- 5 Rändelmutter
- 6 Ansteckkopf
- 7 Handsetzschalter
- 8 Tourenzahlregulierhebel
- 9 Tourenzahlreguliergestänge
- 10 Spannungswähler
- 11 Transportsicherungsschrauben
- 12 Zwischenradfeder
- 13 Schraube zum Verstellen des Armhebers

- 1 Contrepoids
- 2 Vis de fixation du contrepoids
- 3 Relève-bras/repose-bras
- 4 Crochet de fixation du bras
- 5 Ecrrou moletté
- 6 Embout amovible
- 7 Manette de mise en marche
- 8 Levier sélecteur de vitesse
- 9 Commande par tringle des vitesses
- 10 Sélecteur de tension
- 11 Vis de blocage pour le transport
- 12 Ressort de la poulie intermédiaire
- 13 Vis de réglage du relève-bras

- 1 Counterweight
- 2 Tightening knob for counterweight
- 3 Arm rest
- 4 Tonearm securing lever
- 5 Ring to secure plug-in head
- 6 Plug-in head
- 7 Handswitch
- 8 Speed regulating lever
- 9 Speed regulating support
- 10 Voltage selector
- 11 Securing screws for transportation
- 12 Idler wheel spring
- 13 Screw to adjust arm rest

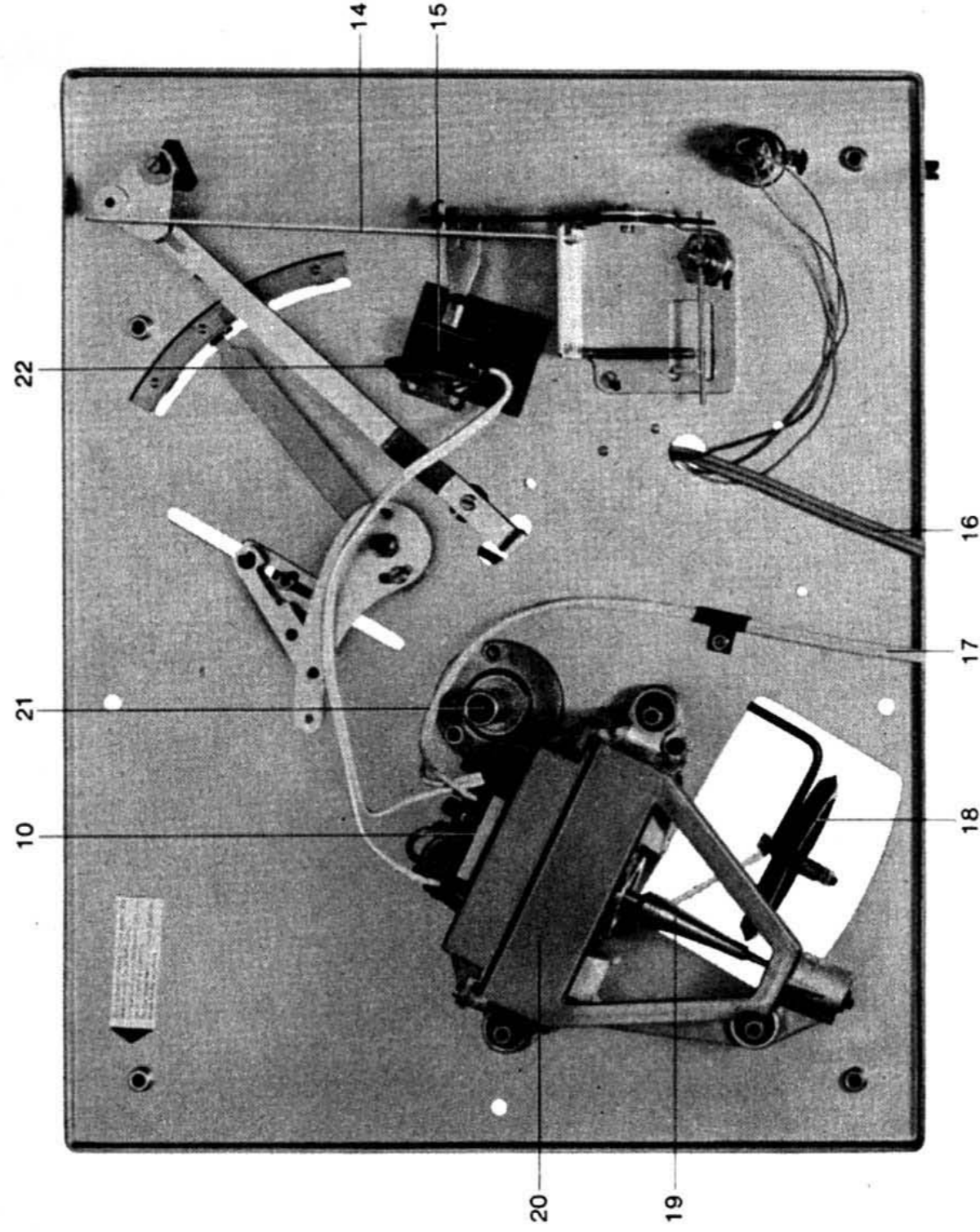

14 Armhebergestänge
mit Hydraulik

15 Kippschalter

16 Tonabnehmerkabel

17 Netzkabel

18 Zwischenrad

19 Konische Motor-
welle

20 Motor

21 Tellerachslager

22 Kondensator

14 Levier de comman-
de du relève-bras

15 Interrupteur

16 Câble de raccorde-
ment du pick-up

17 Cordon de secteur

18 Poulie d'entraîne-
ment du moteur
(roue intermédiaire)

19 Axe conique du
moteur

20 Moteur

21 Axe de plateau

22 Condensateur

14 Arm rest support

15 Toggle switch

16 Pick-up cable

17 Mains cable

18 Idler wheel

19 Conical motor axle

20 Motor

21 Turntable spindle
armature

22 Condenser

Lenco Pick-up-Waage

Für eine einwandfreie, plattenschonende Tonwiedergabe ist es wichtig, daß die für eine Tonzeile angegebene Auflagekraft möglichst genau eingestellt wird.

Der Auflagedruck kann beim B 52-Tonarm verstellt werden, doch ist eine direkte Eichung des Auflagegewichtes in Gramm nicht möglich. Mit der Lenco-Pick-up-Waage können Sie den Auflagedruck genau kontrollieren und wenn nötig nachregulieren. Der Meßbereich der Waage beträgt 0 bis 50 g. Dadurch ist es auch möglich, diese als Briefwaage zu verwenden. Die Waage ist in jedem Fachgeschäft erhältlich.

Balance pèse-bras Lenco

Afin d'obtenir une excellente reproduction et d'éviter toute usure prématurée des disques, il faut régler très précisément la force d'appui indiquée pour la cellule que vous utilisez.

La B 52 permet le réglage de la force d'appui, un étalonnage direct n'est cependant pas possible. A l'aide de la balance pèse-bras Lenco vous pourrez contrôler exactement la force d'appui et la régler, si nécessaire. Cette petite balance peut peser de 0 à 50 g, elle peut donc servir de pèse-lettres aussi. Elle est en vente dans tous les magasins de la branche.

Lenco Pick-up Balance

For perfect, record-protecting sound reproduction, it is important that the pressure weight be adjusted as accurately as possible, to suit the cartridge being used.

On the B 52 tonearm, this pressure weight can be adjusted, although a precise calibration is not possible. With the Lenco pick-up scale, the pressure can be accurately checked, and if necessary regulated. The range of the scale extends from 0 to 50 grams and it can therefore also be used to weight letters. The scale is available at all specialised dealers.

