



**Lenco**

**GL85 Technical Specification  
& Operating Instructions**



**GL85 Technical Specification  
& Operating Instructions**

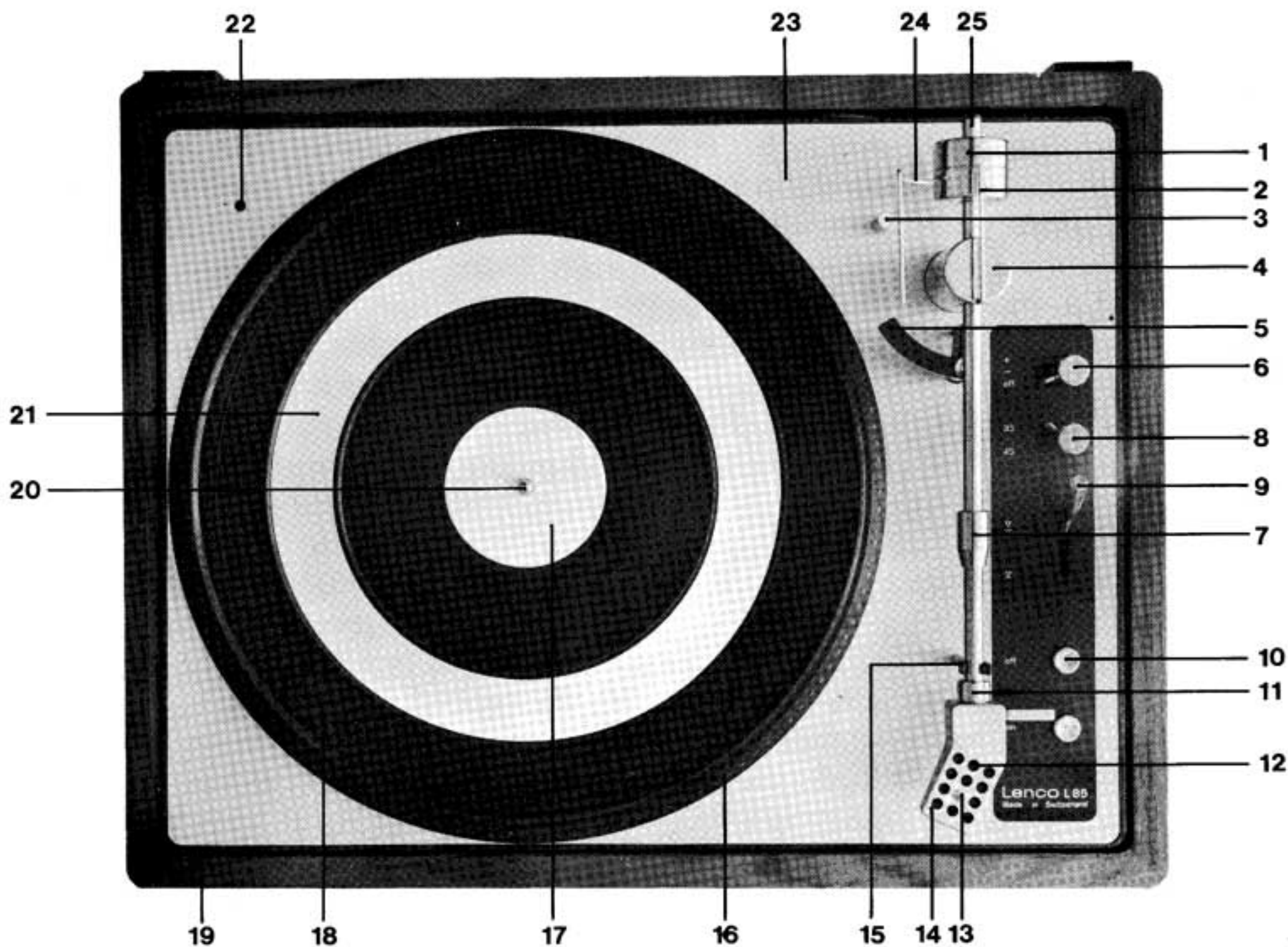

**1** Counter weight.

**2** Support for antiskating device.

**3** Antiskating weight.

**4** Pick-Up pedestal.

**5** Pick-Up lowering arm.

**6** Fine speed adjustment knob.

**7** Stylus pressure adjustment weight.

**8** Speed change knob.

**9** Pick-Up lowering device control lever.

**10** ON/OFF knob.

**11** Pick-Up head securing nut.

**12** Card insert.

**13** Cartridge mounting plate adjusting screw.

**14** Plug-in shell.

**15** Pick-Up rest.

**16** Stroboscope ring. (Turntable with illuminated stroboscope ring).

**17** Decorative plate.

**18** Rubber turntable mat.

**19** Baseplate with plastic edge.

**20** Turntable spindle.

**21** Decorative ring.

**22** Hole for mounting Lencoclean.

**23** Cover plate.

**24** Antiskating bracket.

**25** Pick-Up arm tube.

# Brief Description

The 16-pole synchronous motor, which is completely shielded, is spring-mounted on the steel baseplate.

The drive from the motor to the turntable is via a flat belt.

The Pick-up arm with its counterweight has 4 miniature precision ball races. Stylus pressure is adjustable very accurately from 0-5p for any pick-up cartridge, by means of the sliding weight.

The lightweight interchangeable plug-in shell can accommodate most of the present day cartridges, and the stylus position is adjustable.

The turntable has an illuminated stroboscope round its edge.

The pick-up lowering device is viscously damped, and the pick-up lowering arm is marked with notches to give the correct position for lowering the pick-up on 7", 10" and 12" records.

The turntable has two speeds, 33 $\frac{1}{3}$  and 45 r.p.m. and there is an electronic fine speed adjustment of  $\pm 3\%$ .

An electronically controlled switch, not only stops the motor at the end of the record, but also lifts the arm from the record.

Switching on and off is achieved by press-button switches.

Antiskating device is included with the unit.

## LENCO GL85 Operating Instructions

It will be found helpful to read the setting up instructions in their entirety before carrying them out.

### Unpacking the GL.85.

This unit was carefully checked before leaving the factory. Observe the condition of the packing carton for signs of improper handling in transit. If damage is apparent make an immediate claim to the dealer from whom you made the purchase.

## Setting Up

1 The GL.85 Turntable is supplied built on to a wooden cabinet. In order to avoid damage to the turntable spindle during transit, the turntable is removed and packed separately.

Screw up the two recessed transit screws before placing the turntable on the spindle.

The GL.85 is supplied for connection to 220-250 volt 50 Hz mains. (It is also available for use on 110V 60 Hz mains to special order).

### 2 Interchangeable Plug-In Shell.

The GL.85 is usually supplied without pick-up cartridge, the choice of which is left to the user. An empty plug-in shell is supplied with the unit, together with mounting hardware for your selected cartridge.

### 3 Mounting the Cartridge Into The Plug-In Shell.

Mount the pick-up cartridge on to the mounting plate of the plug-in shell with the screws provided with the unit. These are metric threads.

Place the plug-in shell (14) on the pick-up arm and tighten with the knurled nut (11).

Move pick-up lowering lever (9) forward.

Place the cardboard pick-up template on the turntable with the semi-circular cutout round the pick-up pedestal and the hole "A" over the turntable centre spindle.

Lift the pick-up arm from the rest, (15) slightly loosen the screw (13) on the top of the pick-up head, and place the pick-up over the template.

Slide the cartridge to and fro until the stylus point is exactly on the black line marked on the template. Tighten the screw on the top of the plug-in shell, and check that the stylus still remains on the black line. Should it have moved, repeat this procedure.

Remove the plug-in shell (14) from the pick-up arm again and connect the tags on the leads to the cartridge as follows:—

R	=	Red,	right hand channel.
GR	=	Green,	earth, right hand channel.
L	=	White,	left hand channel.
GL	=	Blue,	earth, left hand channel.

Replace the plug-in shell (14) on the pick-up arm and secure with the knurled nut.

#### **4 Adjusting the Stylus Pressure.**

The stylus pressure is adjusted by means of two weights (1 & 7).

The counter weight (1) at the end of the arm is for balancing out the pick-up arm, and should be placed on the end of the arm with the three screws facing backward.

The sliding weight (7) on the pick-up arm should be adjusted to zero, i.e. with the narrowest edge coinciding with the rearmost calibration mark.

Turn the large counterweight (1) until such time as the arm floats freely and is parallel to the turntable surface. Then adjust to the recommended stylus pressure for the cartridge being used by sliding the sliding weight forward along the pick-up arm tube, each calibration mark on the top surface of the pick-up arm represents 1 gm divisions and those on the side of arm tube indicate half gm divisions.

In order to avoid distortion it is recommended that the stylus pressure is not set too low. Too low a stylus pressure can also lead to increased record wear, as it causes the stylus to vibrate in the record groove and consequently a stylus pressure towards the upper limits recommended by the cartridge manufacturer is advisable.

#### **5 Adjusting the Lowering Device for Clearance.**

Place a record on the turntable.

Lift the pick-up arm and place it above the first groove of the record so that it locates in one of the grooves of the pick-up lowering arm (5).

Move the pick-up lowering arm lever (9) forward, and the pick-up arm will automatically be lowered on to the record.

Turn the knurled screw on the lowering arm until there is a gap of about 2mm between it and the pick-up arm locating pip.

Move the pick-up lowering arm lever (9) backwards and return arm to rest. Should you not require to use the location for 7", 10" and 12" records on

the pick-up lowering arm, a "Terry" clip fitted with a rubber pip is supplied and can be fitted around the arm tube (25) over the existing fixed locating pip.

## 6 Antiskating Device

Due to the geometrical layout of the pick-up arm, a force acting upon it tends to pull it towards the centre of the record. This effect is called "sidethrust" or "skating force" and tends to cause the pick-up to jump one or two grooves when it is lowered on to the record.

A certain degree of distortion is also caused by this sidethrust, in that different stylus pressures are applied to the two walls of the record groove. This distortion, as well as the jumping of the needle in the record groove, can be avoided if this sidethrust is compensated for. For this reason an antiskating device has been coupled to the GL.85 pick-up arm.

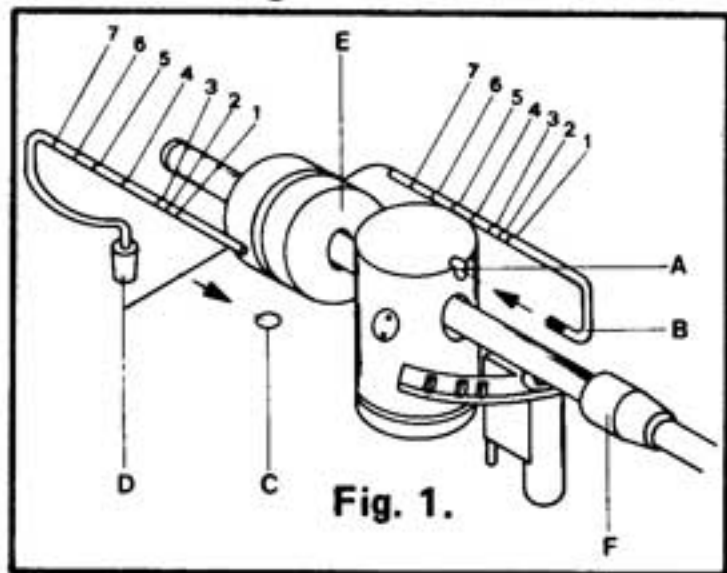

Fig. 1.

## 7 Mounting the Antiskating Device. (See Fig. 1).

Insert Arm (B) in slot (A) and press home. Insert Arm (D) into the hole (C) so that it is parallel with arm (B). Two small antiskating weights of 1 and 4 gr. are supplied.

## Adjusting the Antiskating Device.

Before setting the antiskating device, check again that all the other instructions have been carefully followed.

The setting of the antiskating device depends on two factors, namely stylus pressure and tip radius of the cartridge in use.

Table 1. gives a comprehensive table showing which weight should be used for which tip radius and stylus pressure.

Fig. 2. shows how to attach the antiskating weight.

The notches in Arm (B) are numbered 1-7, starting at the end which is inserted into the arm.

## Example:

To adjust the antiskating force for a pick-up cartridge with a stylus pressure of 1.5p and tip radius of  $18\mu$ .

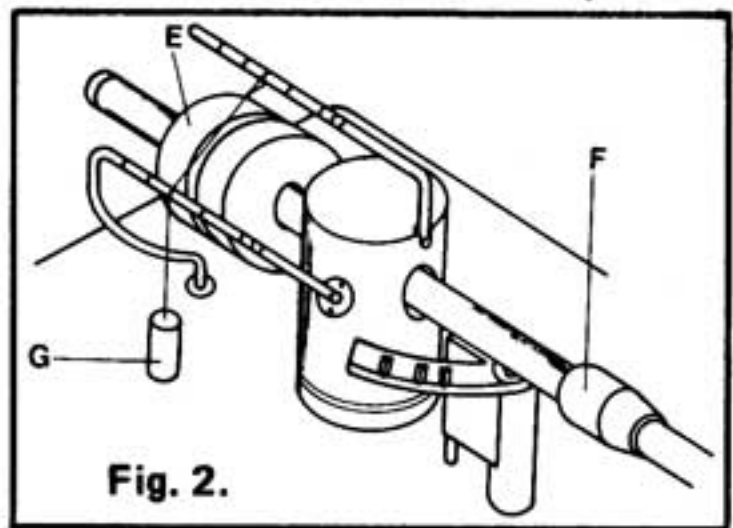

Fig. 2.

Table 1. (on back page) shows that the 1 gm. weight in notch No: 6 should be used. This is done from the intersection of the 1.5p on the horizontal axis with the  $18\mu$  on the vertical axis. Fig. 2. shows the weight (G) threaded over the arm (D) so that it is swinging freely.

## 8 Electrical Connections.

The screened pick-up lead is fitted with 2 phono plugs for connection to the input of the amplifier or radio. The red one is right hand channel the white left.

Once the mains lead is connected to the mains socket, the record player is ready for use.

A separate earth lead is fitted (this is the single lead terminated in a spade and adjacent to the main lead).

This should be connected to the amplifier "earth" or to a convenient external earth point (In some cases this might create a hum loop and in these circumstances this lead should be ignored).

### **9 Levelling the Turntable.**

The GL.85 is mounted on viscously damped springs. In order to mount this precision instrument exactly level the springs are adjustable and have a slot in them so that by inserting a coin into the slot and turning, the height of the springs can be altered. When the unit is supplied mounted on a plinth, then an opening can be found at the bottom of the plinth for this regulation.

**Important.** Before tipping the unit to adjust the level, it is imperative that the turntable is removed. However, to check whether the unit is level the turntable has to be replaced.

## **To Play**

1 Place the pick-up arm on the lowering arm (5) so that it locates in the notch corresponding to the diameter of the record that is to be played.

2 Press the button marked "ON", and the unit will switch on and the turntable start rotating.

3 Turn the speed change knob (8) to the desired speed, either 33 $\frac{1}{3}$  or 45 r.p.m. whilst turntable is rotating.

4 Move the lowering arm lever (9) forward, and the pick-up arm will automatically be lowered on to the record.

5 At the end of the record the incorporated electronic shut-off switch will automatically stop the turntable and lift the pick-up off the record. After this, return the pick-up arm by hand to the pick-up rest (15).

6 Should your playing be interrupted, press the button marked "OFF" (10) and the unit will be switched off. In this instance too the pick-up arm will be raised from the record.

### **To Adjust the Speed.**

An illuminated stroboscope is incorporated into the edge of the turntable (16).

Once the unit has been switched on, the lamp under the stroboscope is lit up.

The upper ring of the stroboscope is for control of 33 $\frac{1}{3}$  r.p.m., whilst the lower ring is for 45 r.p.m.

If the illuminated marks remain static, then the selected speed is correct. Should you require deviation from the correct speed, (for example should you wish to tune the record to a musical instrument), then this can be

done by switching in the electronic fine speed control.

Turn Knob (6) in a clockwise direction until there is a light click. This shows that the electronics has switched on. The speed now will be about 3% slow, and turning the knob further will increase the speed until at the end of its travel it will be about 3% fast. This means that within this tolerance of  $\pm 3\%$  any speed can be achieved. For normal use the knob should remain in the "OFF" position.

Under some circumstances however it will be necessary to switch on the electronic speed control in order to compensate for additional drag imposed by cleaning systems i.e. Lencoclean—Dustbug etc., or slight variation of mains frequency which can occur during extreme peak periods of load during winter.

### Maintenance of Your Record Player.

The bearings built into the unit are self-lubricating and require no further attention.

The stylus should be kept clean of fluff and dust, and a small brush is recommended for this purpose.

**N.B.** It is important that brushing the stylus is done only in one direction, from the rear edge of the pick-up cartridge to the front, otherwise damage might occur to the stylus system. Use of the LENCOCLEAN Record Cleaning System however will keep the stylus clean so that further cleaning is not usually necessary.

Periodically stylus should be inspected under a microscope by a technician. Worn or damaged stylus points cause not only distorted reproduction but also unwanted noises and serious damage to your records.

### To Mount a Lencoclean.

The Lencoclean Record Cleaning System, which cleans the records whilst they are playing, increases the life of your records. It can easily be mounted on the GL.85.

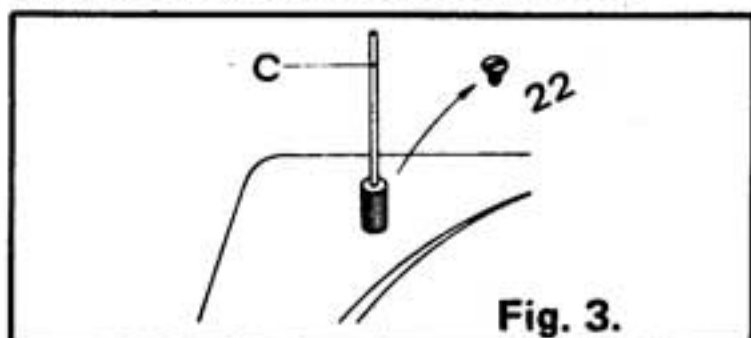

Remove the screw (22) in the far left-hand corner of the baseplate, and in its place mount the spindle "C". Remove the plastic bearing washer from the pedestal supplied with the Lencoclean and place it on spindle "C", and mount the Lencoclean over that.

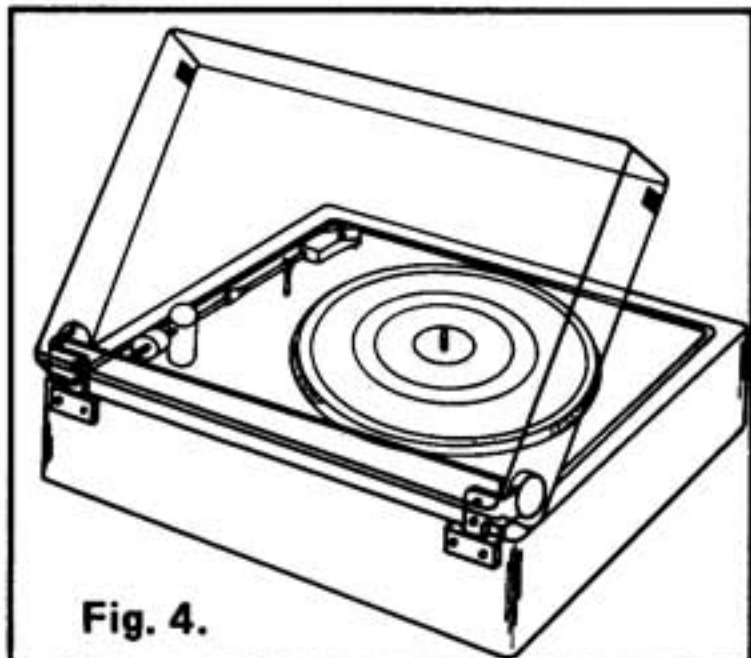

### Dust Cover.

A Matching dust cover is supplied with the professional Hi-Fi Turntable Unit Model L.85 when mounted on a plinth. This dust cover can be inserted into the two brackets at the rear of the wooden plinth. The dust cover itself is fitted with two hinges. These are constructed in such a way that the dust cover will stay up in position down to about  $40^\circ$ .



## Instructions for Adjustment of Auto Stop and Fine Speed Control.

### WARNING:

Switch off mains supply before removing base of plinth when adjustments are necessary.

- 1 Remove turntable from Unit.
- 2 Remove the four rubber feet and take off hardboard base this will now reveal a printed circuit board situated to the right hand side of the centre spindle assembly Fig. 5. On this board all adjustments are made for automatic stop and fine speed control.

### Adjustment of Auto-stop.

The auto-stop is adjusted by the pre-set resistor TP2 (refer to diagram). If the unit is not shutting off at all or only on certain records, turn the pre-set resistor anti-clockwise. This will advance the position at which the auto-stop operates. If the unit is shutting off too soon, then adjustment of the pre-set resistor in a clockwise direction will retard the position at which the auto-stop operates.

Adjustment of the latter pre-set resistor TP2 is **extremely critical** and it is advised that adjustments are made in **small degrees** until the operating position of the auto-stop is correct, obviously if too much adjustment is made then it can be rectified by turning the pre-set resistor in the opposite mode.

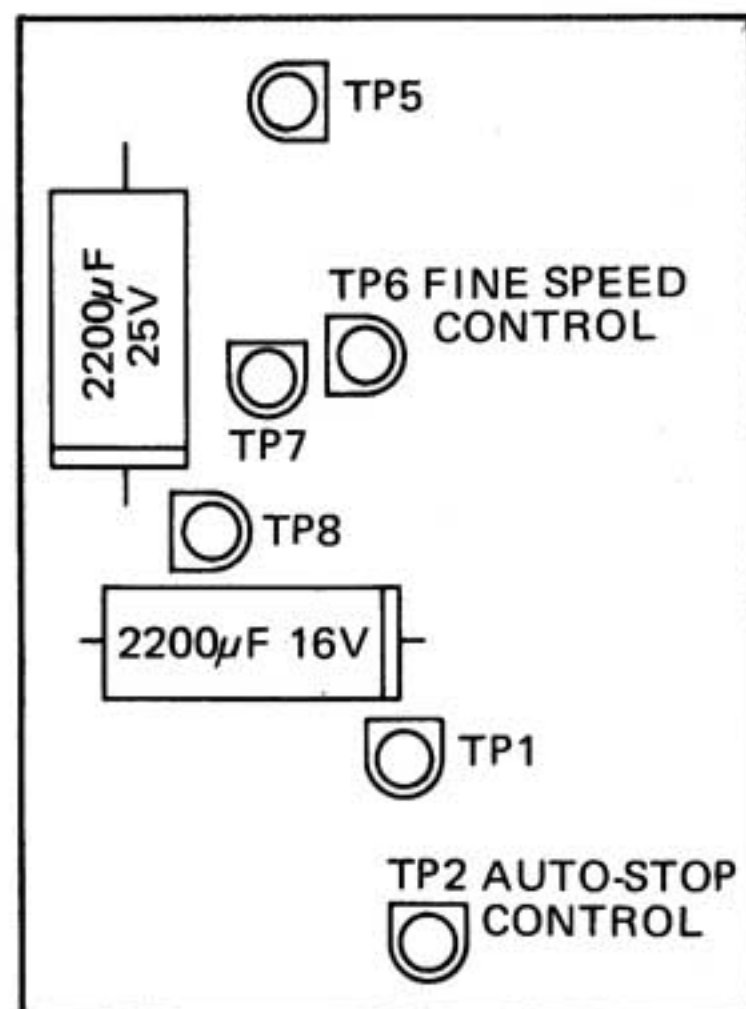

### Adjustment of Fine Speed Control.

The fine speed control is adjusted by the pre-set resistor TP6 (refer to diagram).

With the fine speed control knob at the 1 o'clock position the stroboscope markings should be stationary. If they are not, turn pre-set resistor TP6 until they are stationary.

Fig. 5.

View of printed circuit board, showing position of pre-set resistors. Unit standing on rear of plinth.

# Technical Specification

<b>Speeds:</b>	33 $\frac{1}{3}$ and 45 r.p.m. Electronic fine speed adjustment $\pm 3\%$ .
<b>Wow &amp; Flutter, weighted to DIN 45507:</b>	$\pm 0.08\%$ .
<b>Rumble, unweighted</b>	- 49 dB.
<b>Rumble weighted, to DIN 45539:</b>	- 63 dB.
<b>Turntable:</b>	Diameter 316mm. Weight 1.6 kg. Illuminated stroboscope at edge of turntable.
<b>Pick-Up Arm:</b>	Total length 305mm. Dynamic balancing by counterweight. 4 ball races. Stylus pressure adjustable from 0 - 5p. Separate lever controls pick-up lowering device.
<b>Plug-in Head:</b>	Lightweight metal. Suitable for use with all cartridges with international standard $\frac{1}{2}$ " fixing. Tracking error with correct setting of stylus $\pm 0.6^\circ$ . Tracking angle $26^\circ 13'$ .
<b>Antiskating:</b>	By bias weight.
<b>Motor:</b>	16-pole synchronous motor with belt-drive. Mains voltage 110/220V./50Hz and 110V./60Hz. Power consumption 12VA.
<b>Shut-Off Switch:</b>	The turntable stops and the pick-up is lifted off the record automatically at the end of the record.
<b>Suspension:</b>	Viscously damped spring mounting.
<b>Dimensions:</b>	Baseplate 425 x 325mm. Clearance required below baseplate 60mm. Clearance required above baseplate 68mm. Outside dimension of plinth 460 x 365 x 75mm. Outside dimensions of plinth and lid: 460 x 365 x 142mm.
<b>Weights:</b>	Nett weight of chassis: 7.1 kg. Nett weight of L-85 with lid and plinth: 10.4 kg. Gross weight with lid and plinth including packing: 14 kg.

# Anti-skating settings

Tip radius	Stylus pressure																									
	0.5		0.75		1.0		1.25		1.5		1.75		2.0		2.5		3.0		3.5		4.0		4.5		5.0	
ellipt biradial	1g	1	1g	3	1g	5	1g	7	4g	2	4g	3	4g	4												
12 $\mu$ m .0005" .5 mil	1g	1	1g	3	1g	5	1g	7	4g	1	4g	2	4g	3	4g	4	4g	5								
15 $\mu$ m .0006" .6 mil	1g	1	1g	2	1g	4	1g	6	1g	7	4g	1	4g	2	4g	3	4g	4	4g	5	4g	9				
18 $\mu$ m .0007" .7 mil	1g	1	1g	1	1g	3	1g	5	1g	6	4g	1	4g	1	4g	3	4g	4	4g	4	4g	5	4g	6	4g	7
25 $\mu$ m .001" 1 mil					1g	1	1g	3	1g	4	1g	5	1g	7	4g	1	4g	2	4g	3	4g	4	4g	4	4g	5
TABLE 1	W	N	W	N	W	N	W	N	W	N	W	N	W	N	W	N	W	N	W	N	W	N	W	N	W	N
	Anti-skating setting																									

W = Weight. N = Notch.