

# CONTENTS

## **SECTION 1. GENERAL**

- SERVICING PRECAUTIONS ..... 1-2
- ESD PRECAUTIONS ..... 1-4
- SPECIFICATIONS ..... 1-5
- LOCATION OF CUSTOMER CONTROLS ..... 1-6

## **SECTION 2. AUDIO PART**

- ELECTRICAL TROUBLESHOOTING GUIDE ..... 2-1
- DVD PLAYER PROGRAM DOWNLOAD METHOD ..... 2-5
- WAVEFORMS OF MAJOR CHECK POINT ..... 2-7
- INTERNAL BLOCK DIAGRAM OF IC's ..... 2-8
- IC VOLTAGE SHEET ..... 2-13
- BLOCK DIAGRAM ..... 2-15
- SCHEMATIC DIAGRAMS ..... 2-17
- PRINTED CIRCUIT DIAGRAMS ..... 2-25

## **SECTION 3. DVD PART**

- ELECTRICAL TROUBLESHOOTING GUIDE ..... 3-1
- BLOCK DIAGRAMS ..... 3-8
- SCHEMATIC DIAGRAMS ..... 3-11
- WAVEFORMS ..... 3-19
- PRINTED CIRCUIT DIAGRAM ..... 3-21

## **SECTION 4. MECHANISM ..... 4-1**

## **SECTION 5. EXPLODED VIEWS ..... 5-1**

## **SECTION 6. SPEAKER PART ..... 6-1**

## **SECTION 7. REPLACEMENT PARTS LIST ..... 7-1**

# SECTION 1. GENERAL PART

## SERVICING PRECAUTIONS

### NOTES REGARDING HANDLING OF THE PICK-UP

#### 1. Notes for transport and storage

- 1) The pick-up should always be left in its conductive bag until immediately prior to use.
- 2) The pick-up should never be subjected to external pressure or impact.

Storage in conductive bag

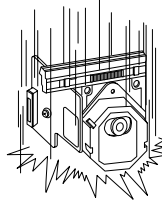
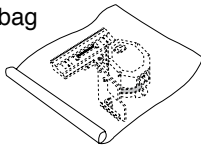

Drop impact

#### 2. Repair notes

- 1) The pick-up incorporates a strong magnet, and so should never be brought close to magnetic materials.
- 2) The pick-up should always be handled correctly and carefully, taking care to avoid external pressure and impact. If it is subjected to strong pressure or impact, the result may be an operational malfunction and/or damage to the printed-circuit board.
- 3) Each and every pick-up is already individually adjusted to a high degree of precision, and for that reason the adjustment point and installation screws should absolutely never be touched.
- 4) Laser beams may damage the eyes!  
Absolutely never permit laser beams to enter the eyes!  
Also NEVER switch ON the power to the laser output part (lens, etc.) of the pick-up if it is damaged.

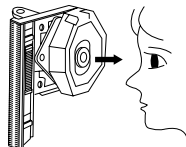

NEVER look directly at the laser beam, and don't let contact fingers or other exposed skin.

#### 5) Cleaning the lens surface

If there is dust on the lens surface, the dust should be cleaned away by using an air bush (such as used for camera lens). The lens is held by a delicate spring. When cleaning the lens surface, therefore, a cotton swab should be used, taking care not to distort this.

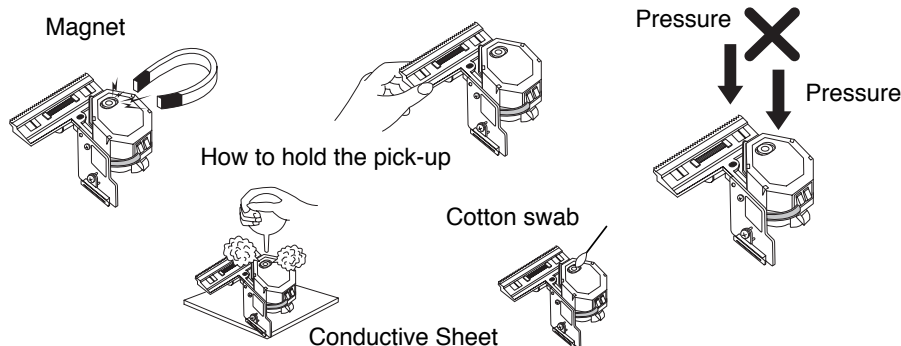

#### 6) Never attempt to disassemble the pick-up.

Spring by excess pressure. If the lens is extremely dirty, apply isopropyl alcohol to the cotton swab. (Do not use any other liquid cleaners, because they will damage the lens.) Take care not to use too much of this alcohol on the swab, and do not allow the alcohol to get inside the pick-up.

# NOTES REGARDING COMPACT DISC PLAYER REPAIRS

## 1. Preparations

- 1) Compact disc players incorporate a great many ICs as well as the pick-up (laser diode). These components are sensitive to, and easily affected by, static electricity. If such static electricity is high voltage, components can be damaged, and for that reason components should be handled with care.
- 2) The pick-up is composed of many optical components and other high-precision components. Care must be taken, therefore, to avoid repair or storage where the temperature of humidity is high, where strong magnetism is present, or where there is excessive dust.

## 2. Notes for repair

- 1) Before replacing a component part, first disconnect the power supply lead wire from the unit
- 2) All equipment, measuring instruments and tools must be grounded.
- 3) The workbench should be covered with a conductive sheet and grounded.  
When removing the laser pick-up from its conductive bag, do not place the pick-up on the bag. (This is because there is the possibility of damage by static electricity.)
- 4) To prevent AC leakage, the metal part of the soldering iron should be grounded.
- 5) Workers should be grounded by an armband (1MΩ)
- 6) Care should be taken not to permit the laser pick-up to come in contact with clothing, in order to prevent static electricity changes in the clothing to escape from the armband.
- 7) The laser beam from the pick-up should NEVER be directly facing the eyes or bare skin.

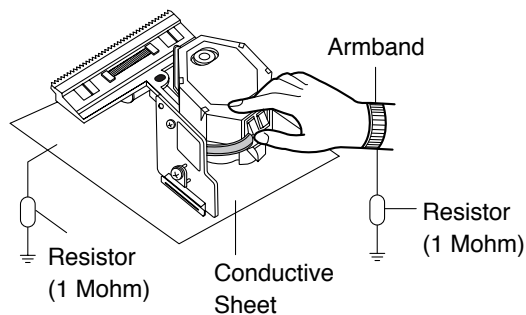

## CLEARING MALFUNCTION

You can reset your unit to initial status if malfunction occur(button malfunction, display, etc.).

Using a pointed good conductor(such as driver), simply short the RESET jump wire on the inside of the volume knob for more than 3 seconds.

If you reset your unit, you must reenter all its settings(stations, clock, timer)

- NOTE:** 1. To operate the RESET jump wire, pull the volume rotary knob and release it.  
2. If you wish to operate the RESET jump wire, it is necessary to unplug the power cord.

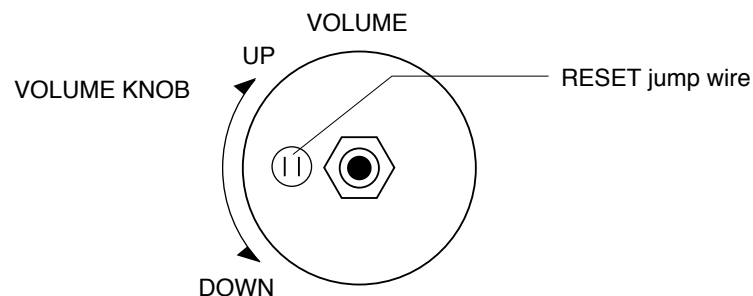

# ESD PRECAUTIONS

## Electrostatically Sensitive Devices (ESD)

Some semiconductor (solid state) devices can be damaged easily by static electricity. Such components commonly are called Electrostatically Sensitive Devices (ESD). Examples of typical ESD devices are integrated circuits and some field-effect transistors and semiconductor chip components. The following techniques should be used to help reduce the incidence of component damage caused by static electricity.

1. Immediately before handling any semiconductor component or semiconductor-equipped assembly, drain off any electrostatic charge on your body by touching a known earth ground. Alternatively, obtain and wear a commercially available discharging wrist strap device, which should be removed for potential shock reasons prior to applying power to the unit under test.
2. After removing an electrical assembly equipped with ESD devices, place the assembly on a conductive surface such as aluminum foil, to prevent electrostatic charge buildup or exposure of the assembly.
3. Use only a grounded-tip soldering iron to solder or unsolder ESD devices.
4. Use only an anti-static solder removal device. Some solder removal devices not classified as "anti-static" can generate electrical charges sufficient to damage ESD devices.
5. Do not use freon-propelled chemicals. These can generate electrical charges sufficient to damage ESD devices.
6. Do not remove a replacement ESD device from its protective package until immediately before you are ready to install it. (Most replacement ESD devices are packaged with leads electrically shorted together by conductive foam, aluminum foil or comparable conductive materials).
7. Immediately before removing the protective material from the leads of a replacement ESD device, touch the protective material to the chassis or circuit assembly into which the device will be installed.

**CAUTION : BE SURE NO POWER IS APPLIED TO THE CHASSIS OR CIRCUIT, AND OBSERVE ALL OTHER SAFETY PRECAUTIONS.**

8. Minimize bodily motions when handling unpackaged replacement ESD devices. (Otherwise harmless motion such as the brushing together of your clothes fabric or the lifting of your foot from a carpeted floor can generate static electricity sufficient to damage an ESD device).

# SPECIFICATIONS

<b>[General]</b>	Power supply		AC 220~240V, 50/60Hz	
	Power consumption		70W	
	Mass		10.2 lbs(4.6kg)	
	External dimensions (W x H x D)		360 x 82 x 388mm(14.2 x 3.2 x 15.3 inches)	
	Operating conditions		Temperature: 5°C to 35°C, Operation status: Horizontal	
	Operating humidity		5% to 90%	
<b>[CD/DVD]</b>	Laser		Semiconductor laser, wavelength 650nm	
	Signal system		PAL 625/50, NTSC 525/60	
	Frequency response(audio)		4 Hz to 20 kHz	
	Signal-to-noise ratio(audio)		More than 90dB(1kHz, NOP, 20kHz LPF/A-Filter)	
	Dynamic range (audio)		More than 95dB	
	Harmonic distortion(audio)		0.15% (1kHz, at 12W position)	
<b>[Video]</b>	Video input		1.0V (p-p), 75Ω, negative syne., RCA jack	
	Video output		1.0V (p-p), 75Ω, negative sync., RCA jack	
	S-video output		(Y) 1.0V (p-p), 75Ω, negative sync., Mini DIN 4-pin x 1 (C) 0.3V (p-p), 75Ω	
<b>[Tuner]</b>	<b>FM</b>	Tuning Range		87.5 ~108MHz
		Intermediate Frequency		10.7MHz
		Signal-to Noise Ratio		50dB
		Frequency Response		150~12,000Hz
	<b>AM(MW)</b>	Tuning Range		530 ~1,810kHz
		Intermediate Frequency		450MHz
<b>[Amplifier]</b>	Stereo mode		30W + 30W(8Ω at 1kHz, THD 1%)	
	Surround mode * Depending on the sound mode settings and the source, there may be no sound output.		Front: 30W+30W Center*: 30W Surround*: 30W +30W(8Ω at 1Hz, THD 1%) Subwoofer*: 30W(8Ω at 60Hz, THD 1%)	
	Inputs		VIDEO 1, 2	
	Outputs		VIDEO 1(AUDIO OUT): 2V WOOFER: 2V	
<b>[Speakers]</b>			Satellite Speaker (FE-3500TE)	Passive Subwoofer(FE-3500WE)
	Type		1 Way 1 Speaker	1 Way 1 Speaker
	Impedance		8Ω	8Ω
	Frequency Response		120~20,000Hz	35~1,000Hz
	Sound Pressure Level		84dB/W(1m)	83dB/W(1m)
	Rated Input Power		30W	30W
	Max. Input Power		60W	60W
	Net Dimensions (W x H x D)		90 x 125 x 106mm	160 x 350 x 325mm
Net Weight		0.7kg	4.78kg	
<b>[Supplied Accessories]</b>	• Audio cable .....		1	
	• Speakers .....		6	
	• Remote control .....		1	
	• AM loop antenna .....		1	
	• Video cable .....		1	
	• Speaker cables .....		5	
	• Batteries .....		2	
	• FM antenna .....		1	

# LOCATION OF CUSTOMER CONTROLS

## FRONT PANEL

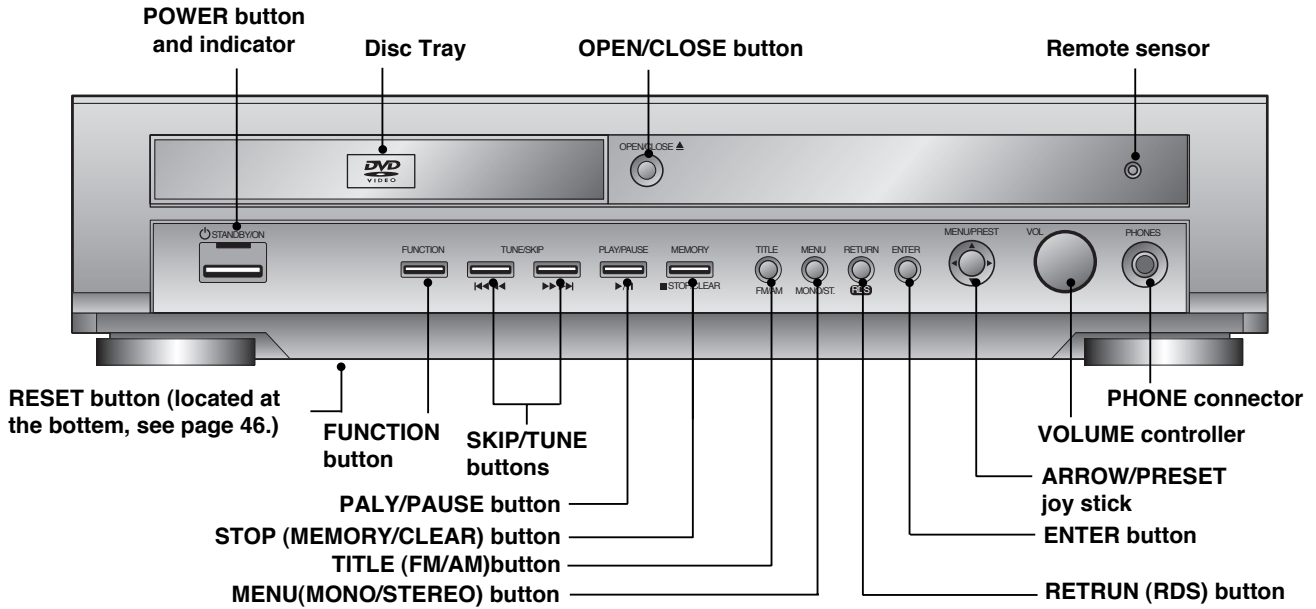

## DISPLAY WINDOW

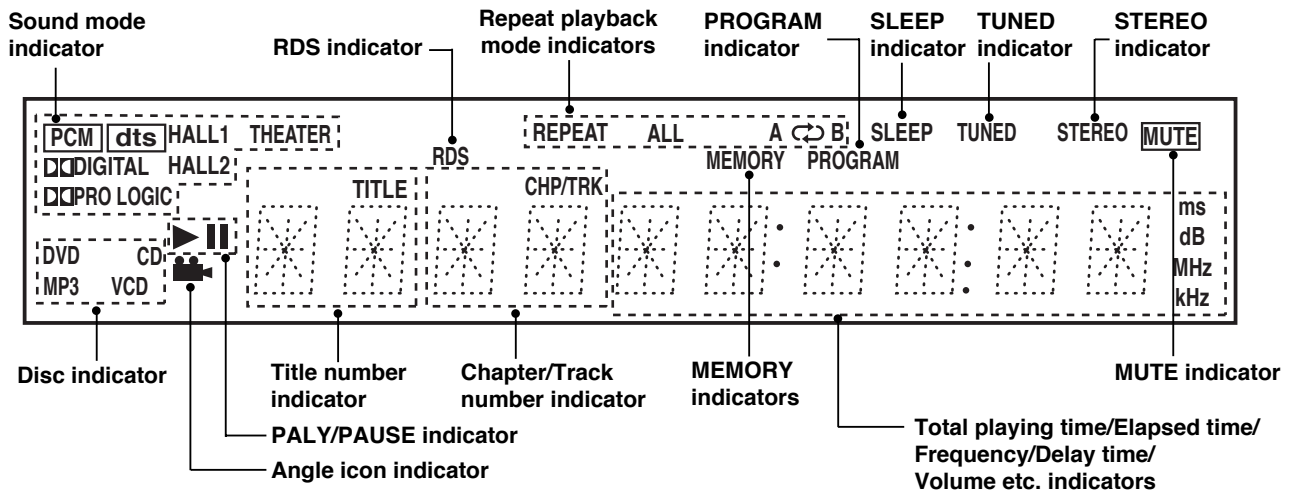

# REAR PANEL

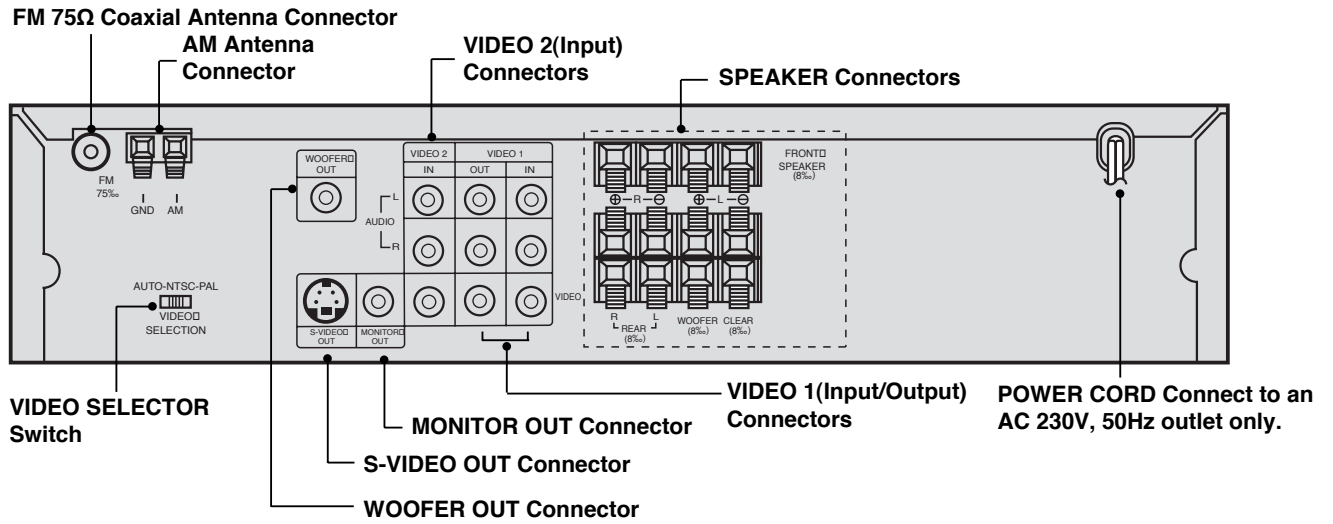

## REAR PANEL

- you will find instructions for each of the remote control functions in the appropriate sections of this instruction manual.

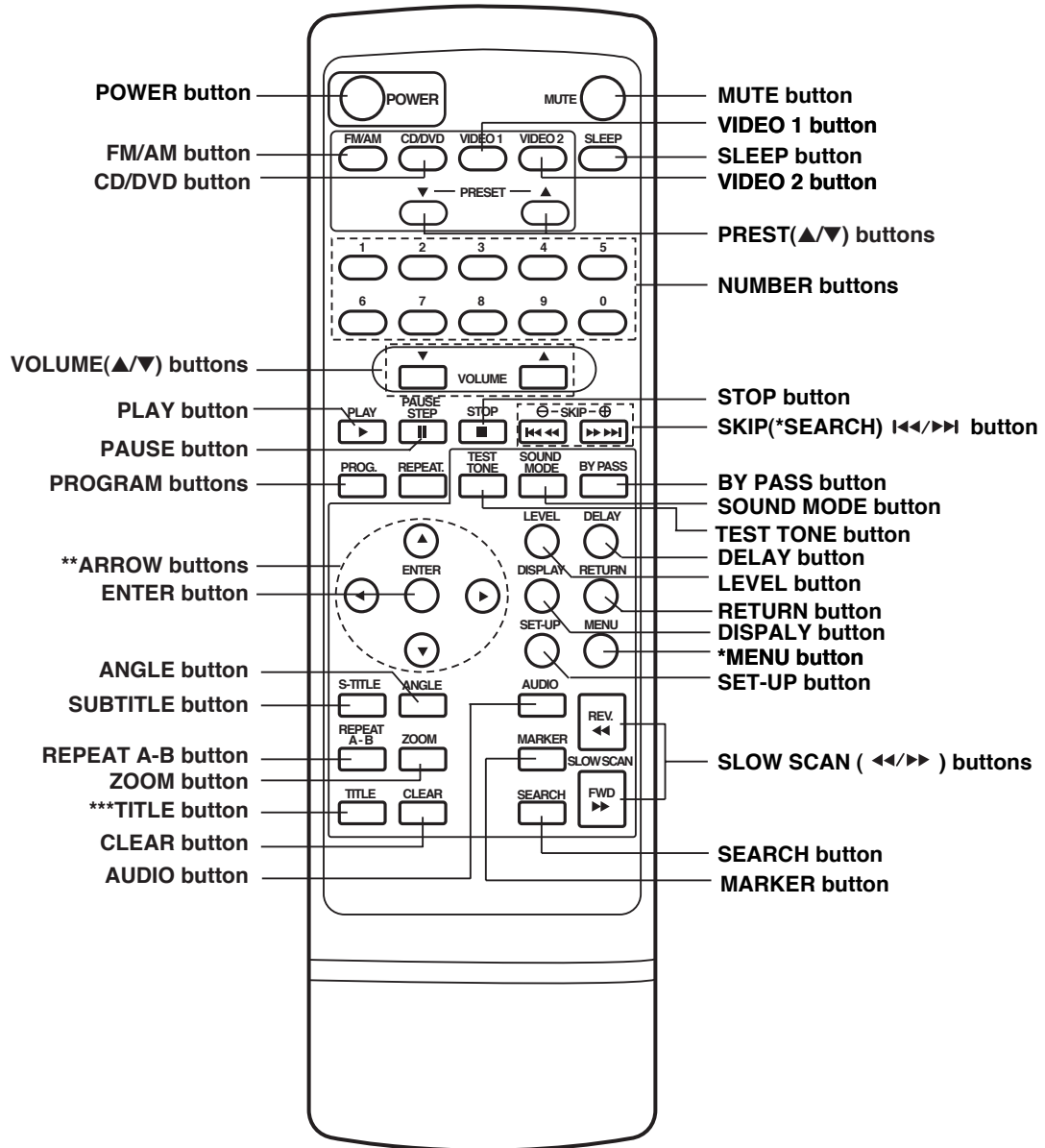

### \*MENU button

Use the MENU button to display the menu screen included on DVD video discs.

### \*\*\*TITLE button

Use the TITLE button to display the title screen included on DVD video discs.

### \*\*Directional arrow buttons

(up, down, left, right) for use in highlighting a selection on a GUI menu screen, TITLE and MENU screen.

\* Press and hold button for about two seconds for search function.



# SECTION 2. AUDIO PART

## ELECTRICAL TROUBLESHOOTING GUIDIE

1.

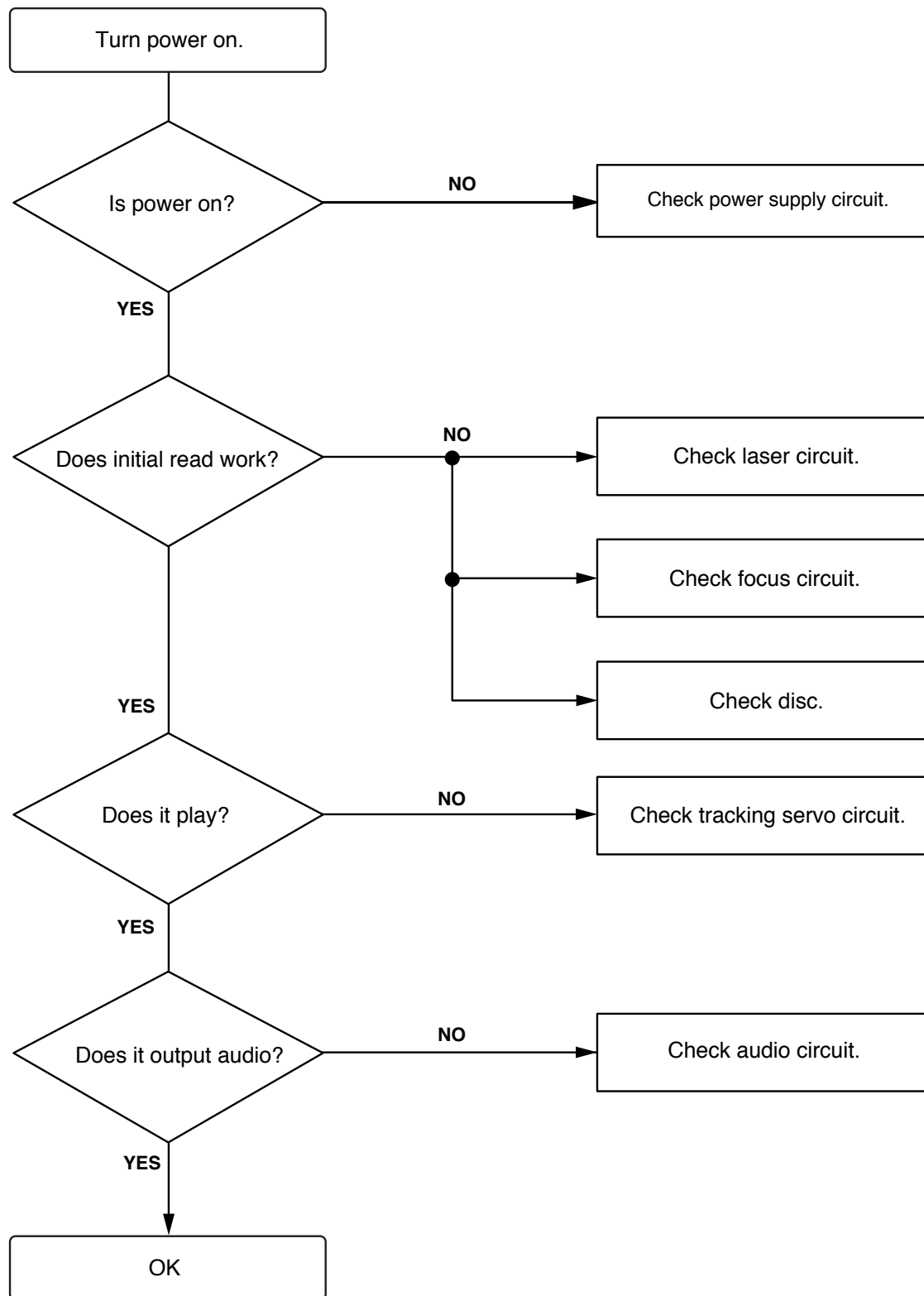

## 2. AUDIO $\mu$ . COM Circuit

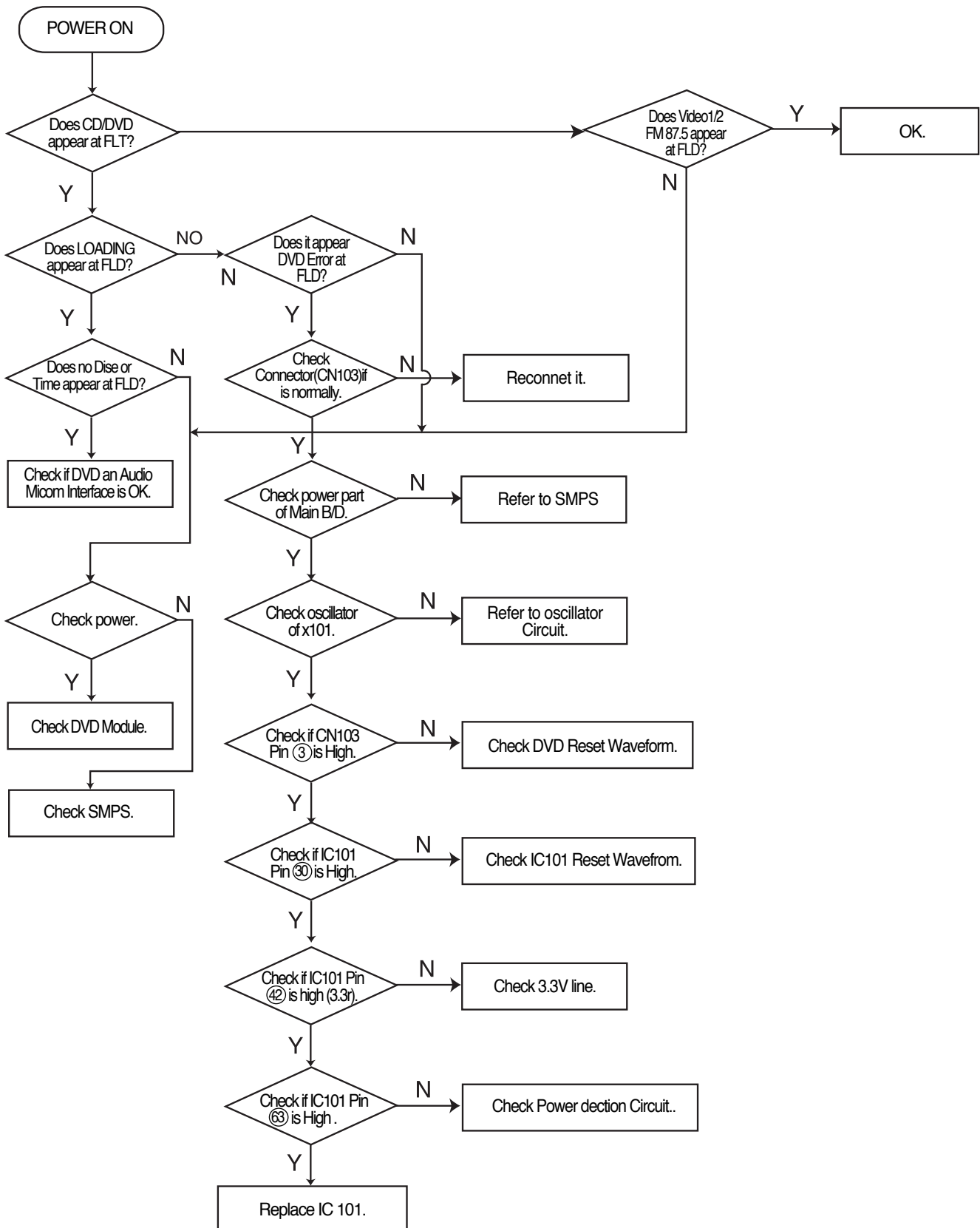

### 3. Front Circuit (1/2)

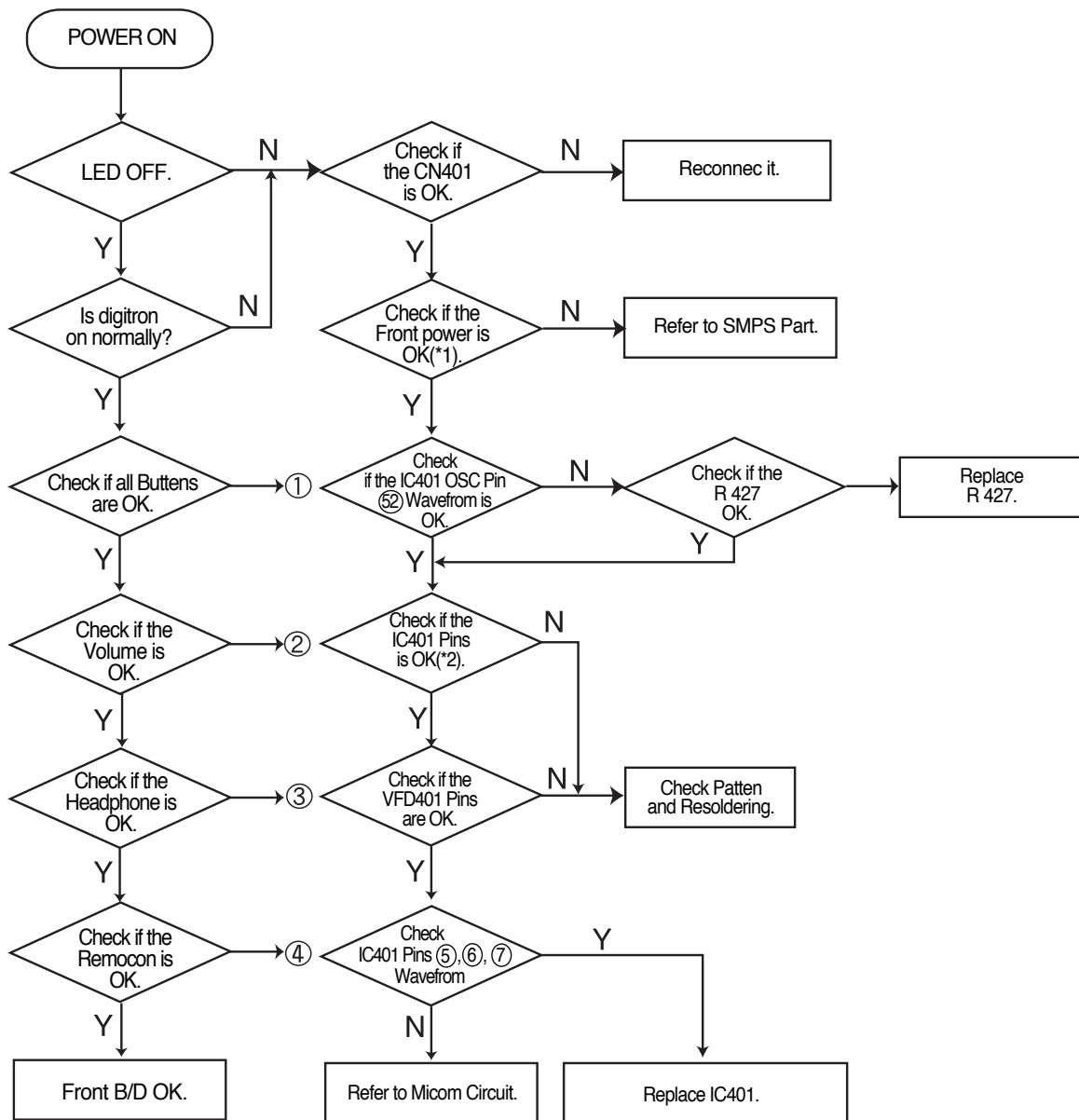

**\* 1: CN401 Pins**  
 Pin 13: +5V  
 Pin 14: -32V  
 Pin 15: -28V  
 Pin 16: -32V

**\* 2: CN401 Pins**  
 Pin 14: +5V  
 Pin 133: -32V

**\* 3: VFD401 Pins**  
 F11 : -28V  
 F22 : -32V

# Front Circuit (2/2)

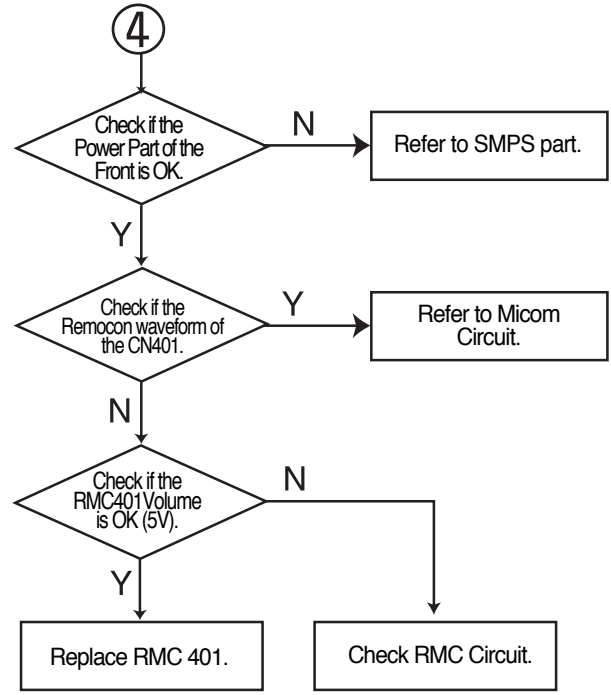
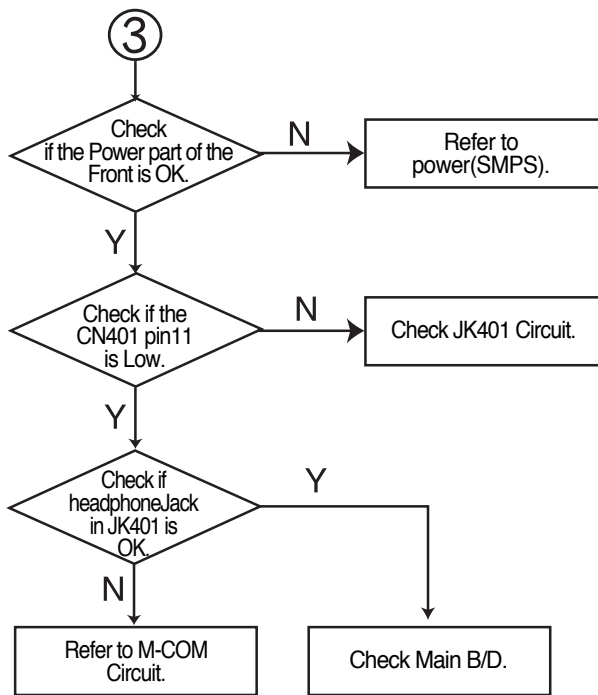
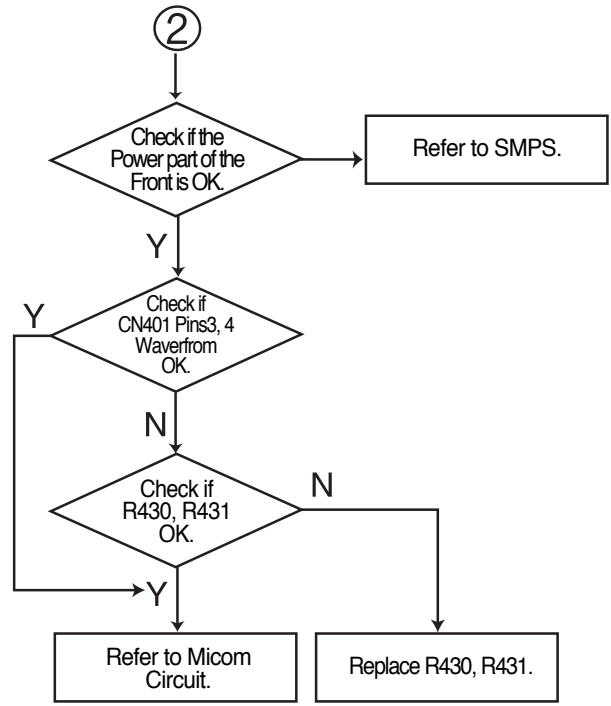
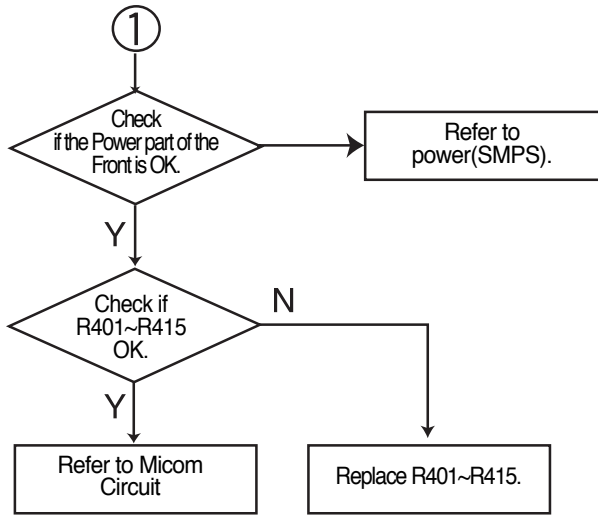

# DVD PLAYER PROGRAM DOWNLOAD METHOD

## 1. DVD player without CD-RW option

### 1-1) Download the DVD program from your PC as following procedure

ACTION	FLD display
<ul style="list-style-type: none"><li>• Plug the Power cord out</li><li>• Connect the Fixture for download (Refer to Deck Mechanism Adjustment)</li><li>• Execute the program for download(Flashrom.exe)</li><li>• Open the DVD program file</li><li>• Plug the Power cord in</li><li>• Press the MENU Key on the Remote controller</li><li>• Select Down icon with injector icon then start download from the P.C</li></ul>	FLASH
■ In status of download	
<ul style="list-style-type: none"><li>• Erased the Flash memory</li><li>• Written the Flash memory</li><li>• Verified the Flash memory</li><li>• Completed the download</li></ul>	FLASH ERA FLASH XX(XX: Program counter) FLASH XX(XX: Program counter) FINISHED
■ If an error was occurred during download, do not unplug the Power cord, and retry the download form the P.C until it is completed.	

## 2. DVD player with CD-RW option(for models using C-CUBE MPEG chip, marking on the IC is ZIVA)

### 2-1) Make the DVD program upgrade Disc as following procedure

\*Recommended S/W: adaptec Easy CD Creator

\*use file format: ISO9660

- Rename the souce file from the P.C to FIRMWARE.BIN  
(Ex, If Source file is lg\_a3\_korea.bin, rename to FIRMWARE.BIN)
- Format the CD-RW Disc as below Make the Folder name to UPGRSADE.DVD under root folder  
(Ex, ₩UPGRADE.DVD)
- Download the source file renamed to FIRMWARE.BIN in the folder  
(Ex, ₩UPGRADE.DVD ₩FIRMWARE.BIN)

**2-2) Insert the upgrade Disc into the DVD player slot, then the DVD player reads the Disc and upgrade the Firmware itself as followings**

<b>Status</b>	<b>FLD display on DVD player</b>
• Detect the upgrade Disc	No display
• Read the Disc	Cd rEAD XX(XX: Program counter)
• Erased the Flash memory	FLASH ERA
• Written the Flash memory	FLASH XX(XX: Program counter)
• Verified the Flash memory	FLASH XX(XX: Program counter)
• Completed the upgrade	FINISHED

**Note:** After completed, plug the Power cord out and in again, and then press the Open key, then the Disc will be ejected.

**Caution:** While CD detecting and reading, if Open key or Power is pressed Then download procedure will be aborted.

**3. DVD player with CD-RW option  
(for models using NS MPEG chip, marking on the IC is PANTERA)**

**3-1) Make the DVD program upgrade Disc as following procedure**

\*Recommended S/W: adaptec Easy CD Creator

\*use file format: ISO9660

- Format the CD-RW Disc as below.  
Make the Folder name to "lg\_dvd ₩UPGRADE ₩lg" under root folder  
( ₩lg\_dvd\_firmware ₩upgrade ₩lg)
- Download the source file in the folder  
(Ex, If the source file is "lg\_a3\_korea.bin, "lg\_dvd ₩firmware ₩upgrade ₩lg ₩lg\_a3\_korea.bin")

**3-2) UPgrade the firmware for DVD player as followings**

<b>ACTION</b>	<b>FLD display on dvd player</b>
• Insert the upgraded Disc into the DVD player slot then starts the detecting	Press Up
• Press the UP key on the Remote controller then starts the reading	READ 0(If error is occurred, displayed retry counter)
- Starts the upgrading	UPGRADE 0(If error is occurred, displayed retry counter)
- Completed the upgrading	FINISHED → checksum
- Opened the Tray Disc	("FINISHED → checksum" is displayed repeatedly at 2 second intervals)
• Plug the Power Cord out	

**Note:** In the status of FLD with "READ 0" or "UPGRADE 0"  
If an error is occurred, the read counter, "READ 0", shows retry counter or "ERROR num"  
If the num has 0~2, retry the firmware upgrade procedure.  
If the error is continued after retrying 5 times, replace the Flash ROM IC.

# WAVEFORMS OF MAJOR CHECK POINT

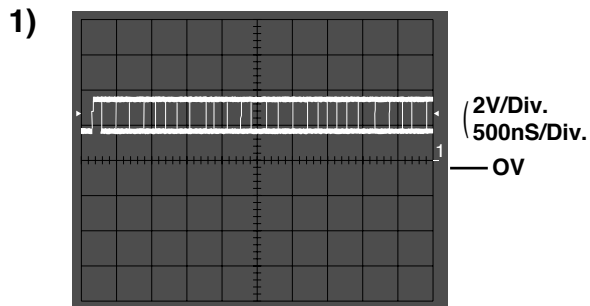

- IC 703 pin ④
- SPDIF signal waveform during normal play.

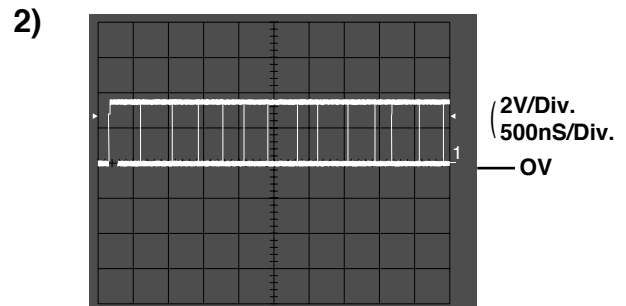

- IC 703 pin ⑱
- Serial data output waveform during normal play.

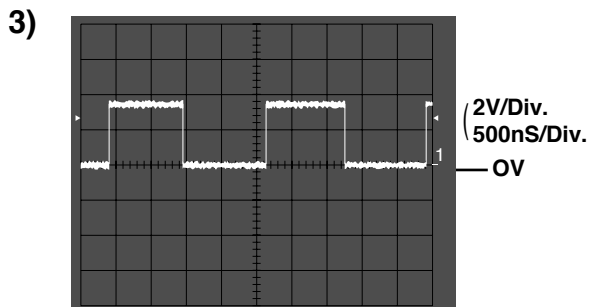

- IC 202 pin ③
- L/R clock data input waveform during normal operation.

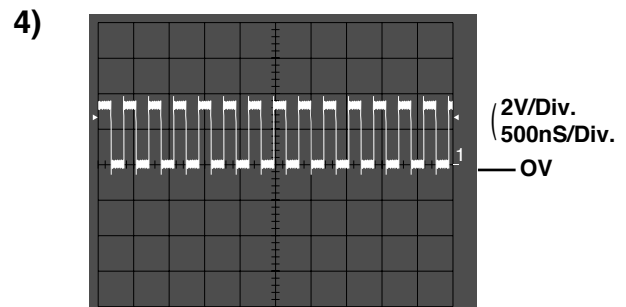

- IC 202 pin ④
- Bit clock data input waveform during normal operation.

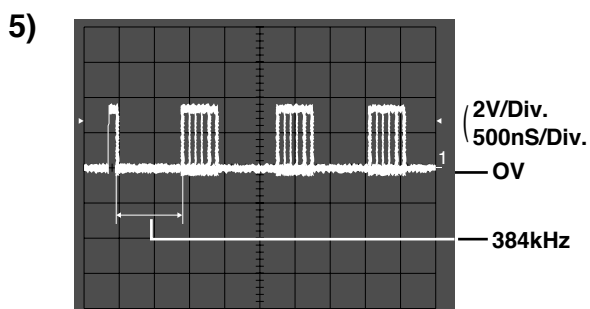

- IC 202 pin ⑳, ㉑, ㉒, ㉓
- PWM data output waveform during normal operation.

# INTERNAL BLOCK DIAGRAM OF ICs

## ■ CXP 84332

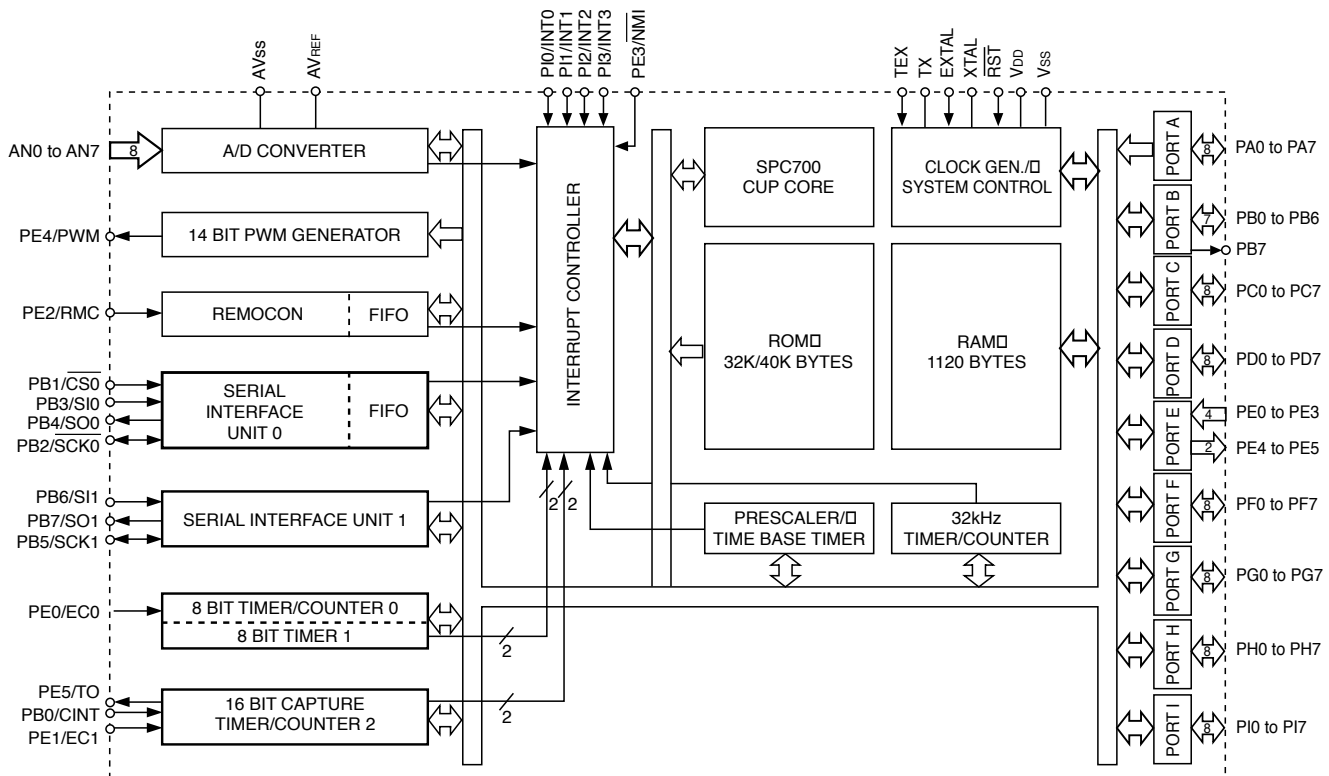

## ■ PIN DESCRIPTION

symbol	I/O	Description	
PA0/AN0 to PA7/AN7	I/O/Analog input	(Port A) 8-bit I/O port. I/O can be set in a unit of single bits. Incorporation of the pull-up resistance can be set through the software in a unit of 4 bits. (8 pins)	Analog inputs to A/D converter.(8 pins)
PB0/CINT	I/O/Input	(Port B) Lower 7-bit I/O port in which I/O can be set in a unit of single bits. Also, an uppermost bit (PB7) exclusively for output. Incorporation of pull-up resistor can be set through the software in a unit of 4 bits. (8 pins)	External capture input to 16-bit timer/counter.
PB1/CS0	I/O/Input		Chip select input for serial interface(CH0).
PB2/SCK0	I/O/I/O		Serial clock I/O (CH0).
PB3/SI0	I/O/Input		Serial data input (CH0).
PB4/SO0	I/O/Output		Serial data Output (CH0).
PB5/SCK1	I/O/I/O		Serial clock I/O (CH1).
PB6/SI1	I/O/Input		Serial data input (CH1).
PB7/SO1	Output/Output		Serial data Output (CH1).
PC0 to PC7	I/O	(Port C) 8-bit I/O port. I/O can be set in a unit of single bits. Capable of driving 12mA sink current. Incorporation of Pull-up resistor can be set through the software in a unit of 4 bits. (8 pins)	



symbol	I/O	Description	
PD0 to PD7	I/O	(Port D) 8-bit I/O port. I/O can be set in a unit of single bits. Incorporation of pull-up resistor can be set through the software in a unit of 4 bits. (8 pins)	
PE0/ $\overline{EC0}$	Input/Input	(Port E) 6-bit port. Lower 4 bits are for inputs; upper 2 bits are for outputs. Incorporation of pull-up resistor can be set through the software. (8 pins)	External event inputs for timer/counter.(2 pins)
PE1/ $\overline{EC1}$	Input/Input		Remote control reception circuit input.
PE2/RMC	Input/Input		Non-maskable interruption request input.
PE3/ $\overline{NMI}$	Input/Input		14-bit PWM output.
PE4/ $\overline{PWM}$	Output/Output		Rectangular wave output for 16-bit timer/counter. Output for 32kHz oscillation frequency demultiplication.
PE5/TO/ADJ	Output/Output/Output		
PE0 to PF7	I/O	(Port F) 8-bit I/O port. I/O can be set in a unit of single bits. Incorporation of pull-up resistor can be set through the software in a unit of 4 bits (8 pins)	
PG0 to PG7	I/O	(Port G) 8-bit I/O port. I/O can be set in a unit of single bits. Incorporation of pull-up resistor can be set through the software in a unit of 4 bits (8 pins)	
PH0 to PH7	I/O	(Port H) 8-bit I/O port. I/O can be set in a unit of single bits. Incorporation of pull-up resistor can be set through the software in a unit of 4 bits (8 pins)	
PI0/INT0 to PI3/NT3	I/O/Input	(Port I) 8-bit I/O port. I/O can be set in a unit of single bits. Incorporation of pull-up resistor can be set through the software in a unit of 4 bits (8 pins)	
PI4 to PI7	I/O	External interruption request inputs.	
EXTAL	Input	Crystal connectors for system clock oscillation. When the clock is supplied externally, input to EXTAL; opposite phase clock should be input to XTAL.	
XTAL	Output		
TEX	Input	Crysal connectors for 32kHz timer/counter colck oscillation circuit. Connect a 32kHz crystal oscillator between TEX and TX.	
TX	Output	For usage as event input, connect clock oscillation source to TEX, and open TX.	
RST	Input	Low-level active, system reset.	
NC		NC. Under normal operating conditions, connect to $V_{DD}$	
$AV_{REF}$	Input	Reference voltage input for A/D converter.	
$AV_{SS}$		A/D converter GND.	
$V_{DD}$		Positive power supply.	
$V_{SS}$		GND	

# ■ STA304

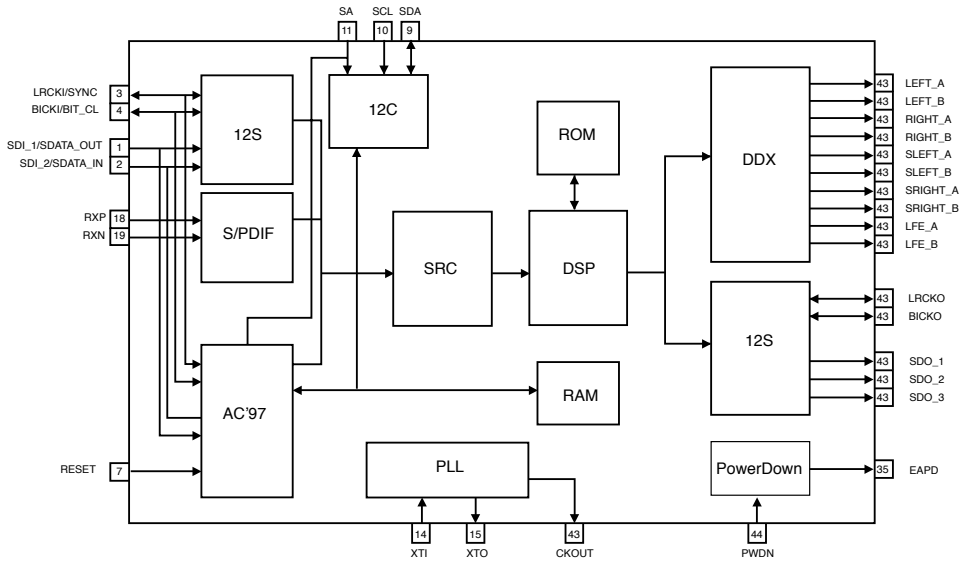

# ■ STA500

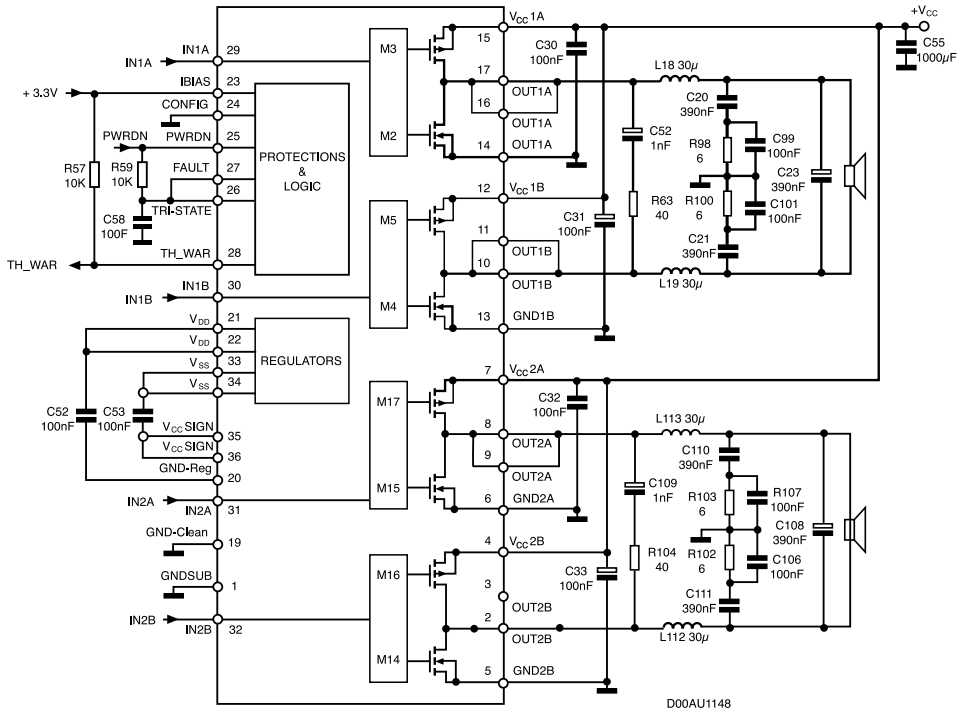

# CS4228

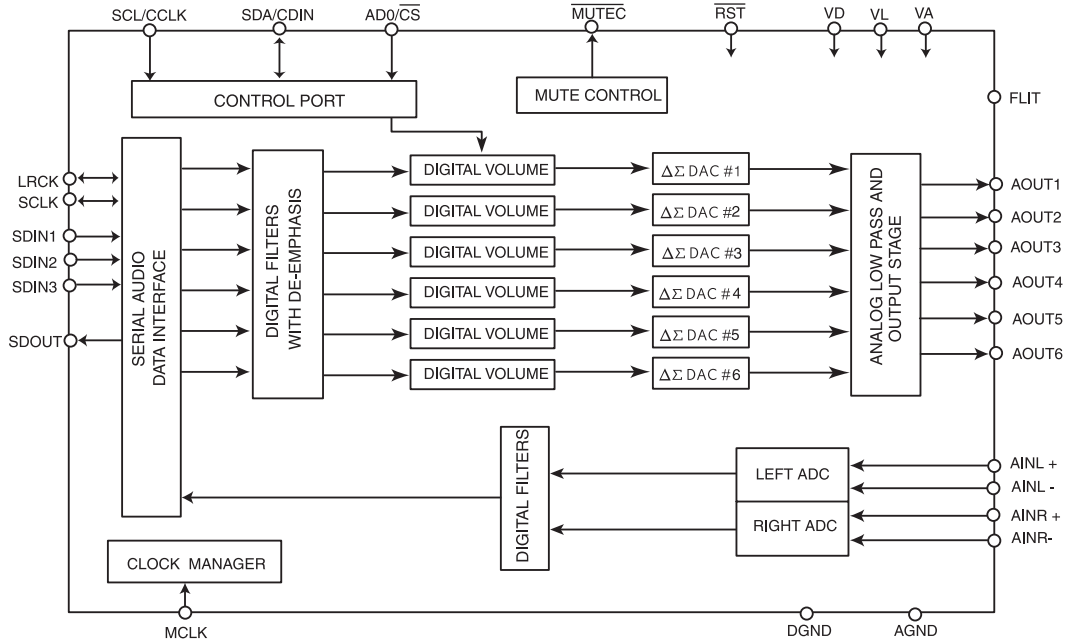

# CS49300

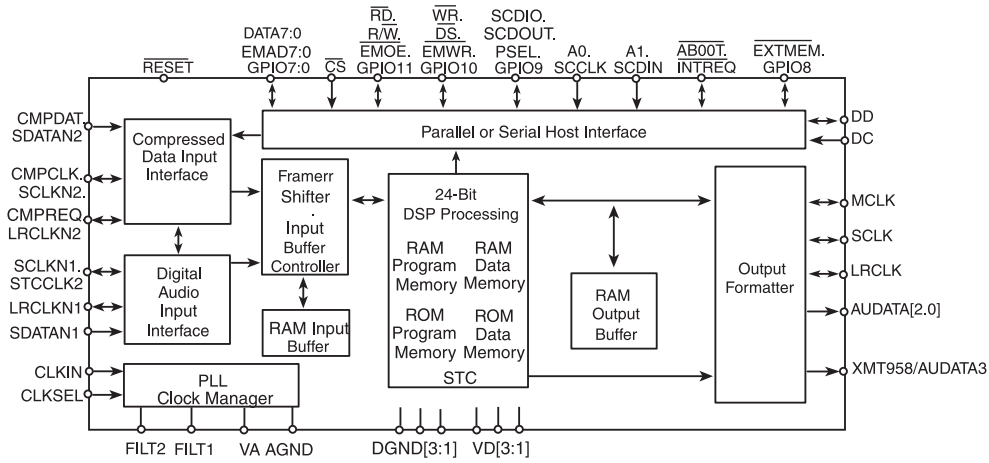

# CS8415A

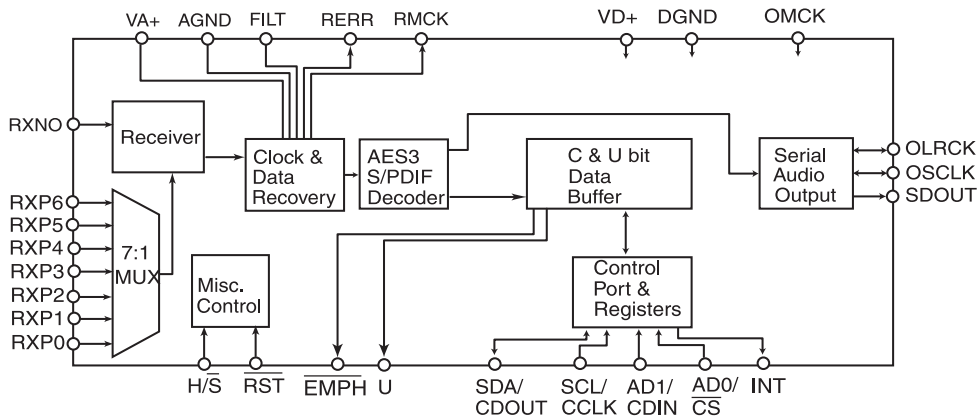

# ■ $\mu$ PD16311

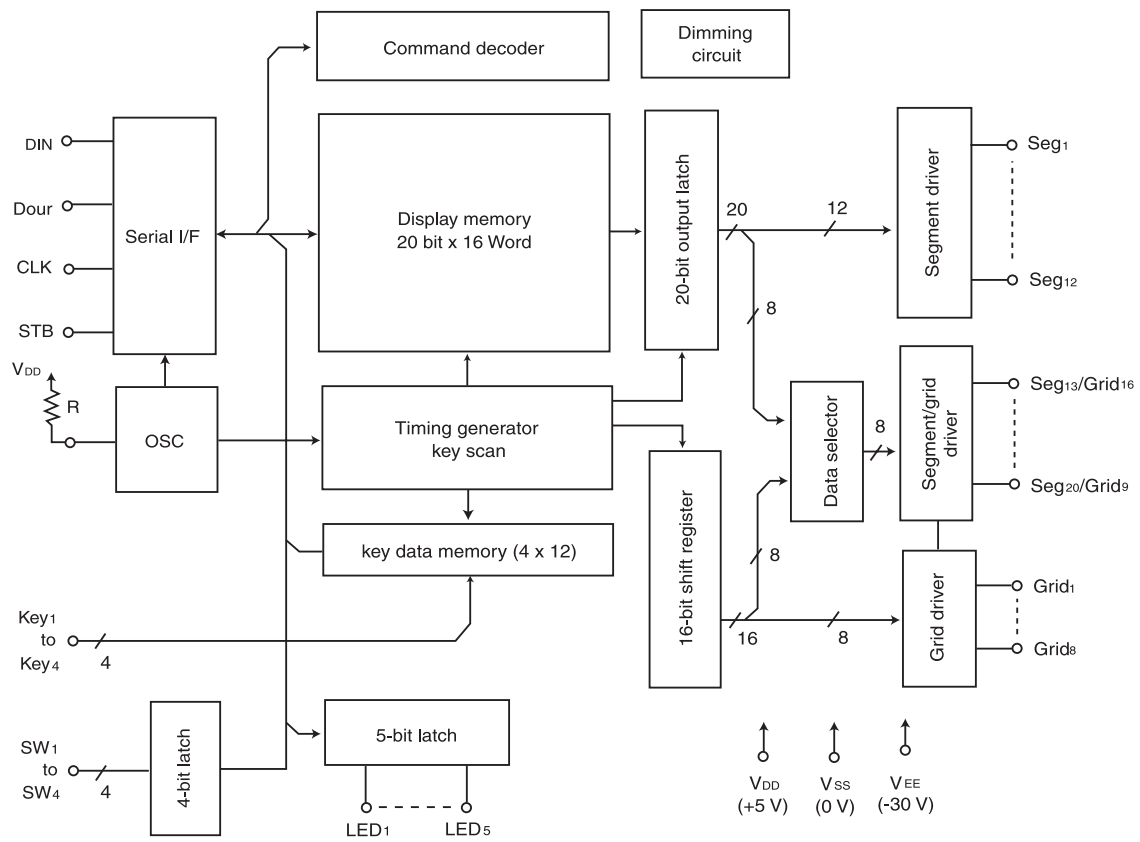

# ■ NJM2279

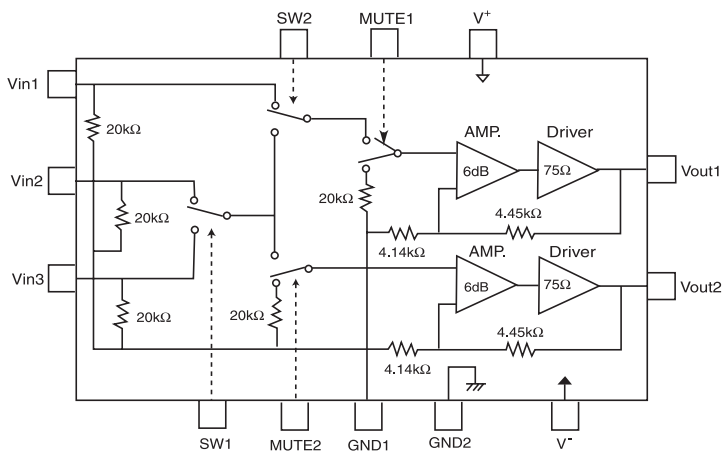

# ■ NJU7312A

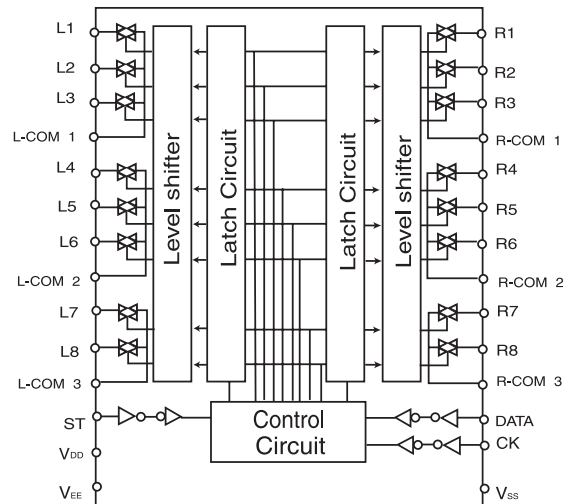

# IC VOLTAGE SHEET

## ■ STA500 (IC201, IC301, IC801)

PIN No.	Volt(V)
1	
2	
3	
4	27.5
5	
6	
7	27.5
8	
9	
10	
11	
12	27.5
13	
14	
15	27.5
16	
17	
18	
19	
20	
21	
22	
23	3.3
24	
25	
26	
27	
28	
29	
30	
31	
32	
33	
34	
35	
36	

## ■ NJM 2279 (IC102)

PIN No.	Volt(V)
1	0
2	2
3	0
4	5
5	1.3
6	0
7	0
8	5
9	0
10	1.3
11	0
12	1.4
13	5
14	-5

## ■ STA304 (IC202, IC302)

PIN No.	Volt(V)
1	0
2	1.6
3	1.6
4	
5	3.3
6	
7	3.2
8	0
9	3.2
10	3.2
11	
12	0
13	3.3
14	1.5
15	1.6
16	
17	0
18	0
19	0
20	0
21	0
22	0
23	0
24	0
25	0
26	3.2
27	0
28	0
29	0
30	0
31	0
32	3.2
33	0
34	0
35	3.3
36	1.6
37	0
38	0
39	0
40	1.6
41	0
42	3.3
43	0
44	3.3

## ■ CX84332 (IC101)

PIN No.	Volt(V)	PIN No.	Volt(V)
1	5	41	5
2	2.5	42	0
3	0	43	0
4	0	44	0
5	0	45	5
6	5	46	0
7	5	47	1.7
8	5	48	3.9
9	9	49	5
10	0	50	2.6
11	0	51	5.5
12	0	52	5.4
13	5	53	2
14	0	54	5
15	5	55	5
16	5	56	4.6
17	5	57	0
18	5	58	4.5
19	5	59	5
20	5	60	4.8
21	5	61	5
22	5	62	5
23	5	63	5
24	5	64	5
25	5	65	5
26	0	66	3.4
27	0	67	4.9
28	0	68	0
29	5	69	0
30	5	70	0
31	5	71	5
32	5	72	5
33	0	73	5
34	5	74	3.5
35	0	75	0
36	0	76	0
37	5	77	5
38	5	78	0
39	5	79	5
40	5	80	5

## ■ CS8415(IC701)

PIN No.	Volt(V)	PIN No.	Volt(V)
1	2.8	15	0
2	2.9	16	1.6
3	3.2	17	1.6
4	2.8	18	0
5	2.8	19	3
6	5	20	0
7	0	21	0
8	2.2	22	3
9	1.6	23	0
10	1.6	24	0
11	0	25	0
12	0	26	3
13	0	27	0
14	0	28	

■ UPD16311(IC401)

PIN No.	Volt(V)	PIN No.	Volt(V)
1	28.9	27	-26
2	29	28	-19
3	29	29	-31
4	29	30	-31
5	5	31	-29
6	2	32	-29
7	5	33	5
8	3.9	34	-32
9	0	35	-29
10	0	36	-29
11	0	37	-29
12	0	38	-29
13	0	39	-29
14	5	40	-29
15	-18	41	-29
16	-26	42	-29
17	-28	43	-29
18	-30	44	-29
19	-20	45	5
20	-28	46	0
21	-28	47	0
22	-21	48	0
23	-23	49	0
24	-30	50	0
25	-3	51	
26	-28	52	2.8

■ NJU7312AM(IC501)

PIN No.	Volt(V)	PIN No.	Volt(V)
1	-12	16	0
2	0	17	0
3	0	18	0
4	0	19	0
5	0	20	0
6	0	21	0
7	0	22	0
8	0	23	0
9	0	24	0
10	0	25	0
11	0	26	0
12	0	27	0
13		28	0
14		29	0
15		30	12

■ CS49326(IC704)

PIN No.	Volt(V)	PIN No.	Volt(V)
1	2.4	23	2.5
2	0	24	
3	0	25	1.6
4	0	26	1.6
5		27	1
6	2.9	28	1.6
7	0	29	1.6
8	2.4	30	1
9	2.4	31	0
10	2.4	32	2
11	2.4	33	1.3
12	2.5	34	2.5
13	0	35	0
14	2.4	36	3.2
15	2.4	37	2.5
16	2.4	38	2.5
17	2.4	39	0
18	3.2	40	0
19	1.7	41	0
20	2.4	42	1.6
21	2.4	43	1.6
22	0	44	1.6

■ CS4228 (IC705)

PIN No.	Volt(V)	PIN No.	Volt(V)
1	0	16	2.5
2	0	17	2.2
3	0	18	3.5
4	1.5	19	2.2
5	1.5	20	2.2
6	1.5	21	5
7		22	
8	3.2	23	2.3
9	2.5	24	2.3
10	1.6	25	2.3
11	0	26	2.3
12	2.9	27	2.3
13	3.2	28	2.3
14	3.2	29	2.3

■ IC910

PIN No.	Volt(V)
1	
2	
3	-12

■ IC921

PIN No.	Volt(V)
1	
2	12
3	

■ IC923

PIN No.	Volt(V)
1	
2	5
3	

■ IC911

PIN No.	Volt(V)
1	
2	
3	-5

■ IC922

PIN No.	Volt(V)
1	
2	8.1
3	

■ IC924

PIN No.	Volt(V)
1	
2	3.3
3	

■ PN901, CN901

PIN No.	Volt(V)
1	-30
2	-25
3	-37
4	-37
5	-37
6	5.1
7	
8	
9	
10	

■ PN902, CN902

PIN No.	Volt(V)
1	27.6
2	27.6
3	27.6
4	16.9
5	5.8
6	5.8
7	0
8	
9	
10	5.8

■ IC926

PIN No.	Volt(V)
1	
2	3.3
3	

# BLOCK DIAGRAM

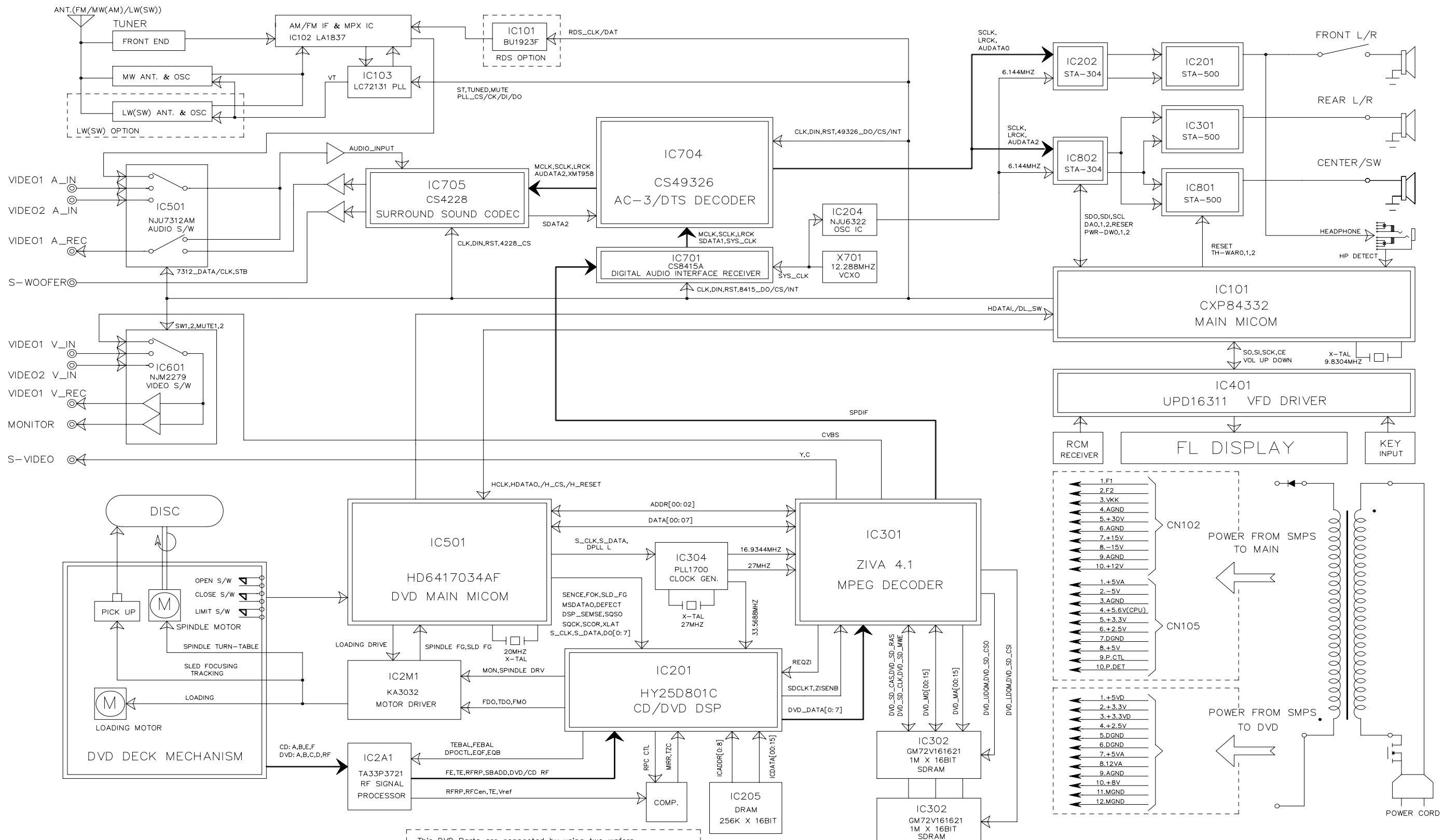

This DVD Parts are connected by using two wafers.  
One is 12 pins Power wafer from SMPS power board,  
and the other is 23 pins Control & Signal wafer from main board.

BLOCK DIAGRAM  
DA-3520  
SI2960

# SHEMATIC DIAGRAMS

## • POWER SCHEMATIC DIAGRAM

**NOTE: Warning**  
 Parts that are shaded are critical With respect to risk of fire or electrical shock.

**NOTE:**  
 1. Shaded (■) parts are critical for safety. Replace only with specified part number.  
 2. Voltages are DC-measured with a digital voltmeter during Play mode.

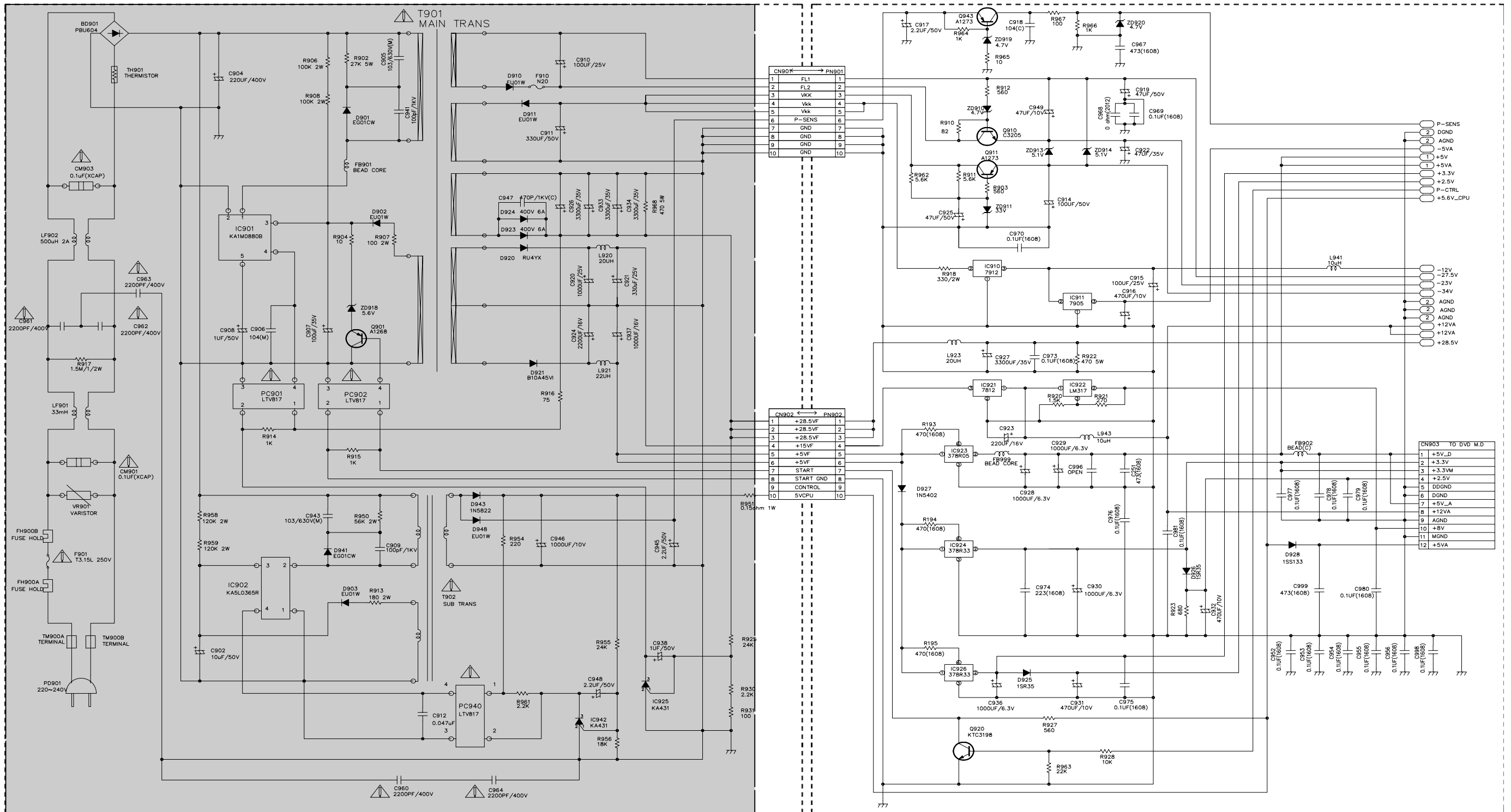



# • μ-COM & FRONT SCHEMATIC DIAGRAM

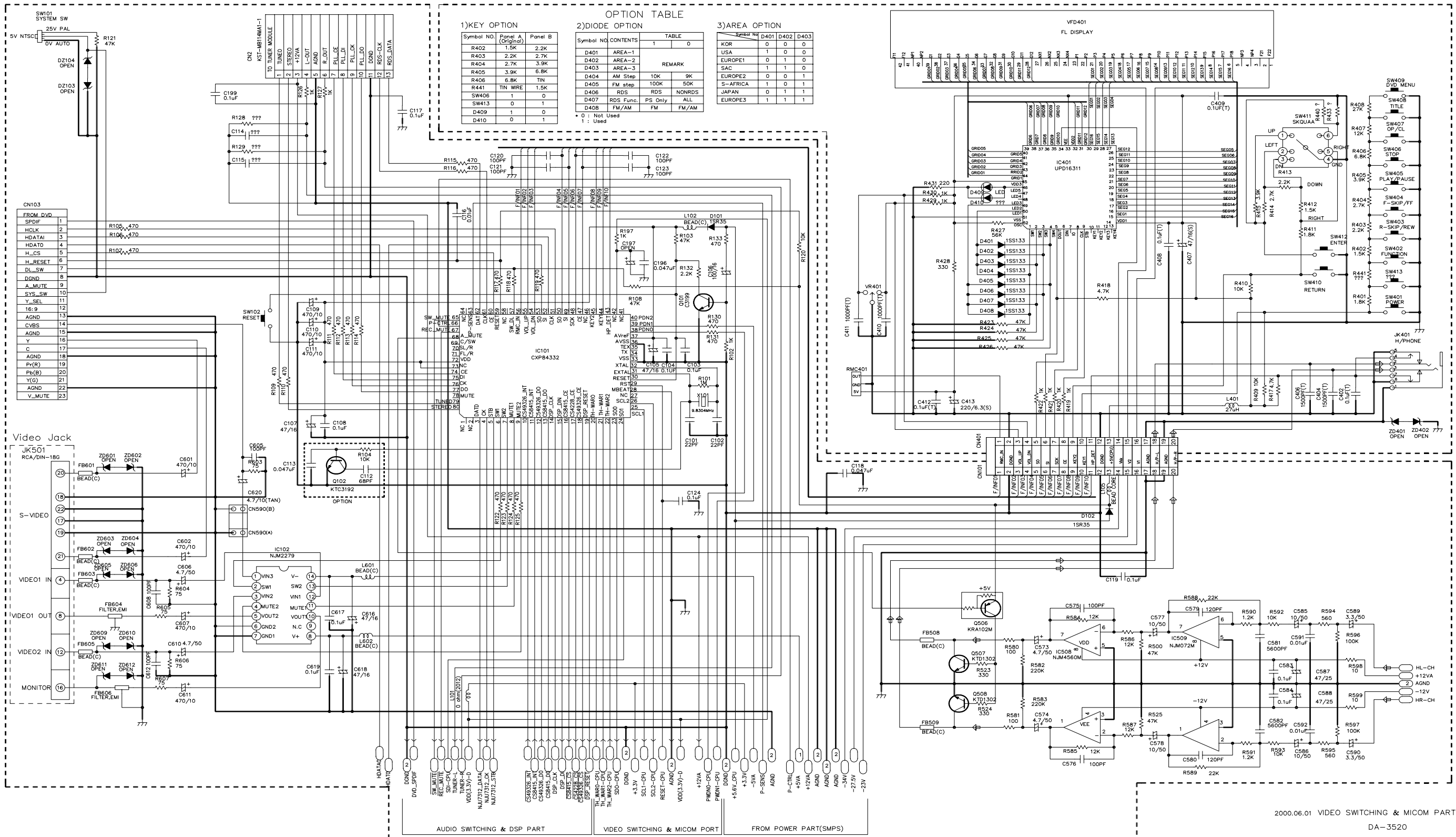

2000.06.01 VIDEO SWITCHING & MICOM PART  
DA-3520  
SI2910

# • DAP(Digital Amplifier Part) SCHEMATIC DIAGRAM

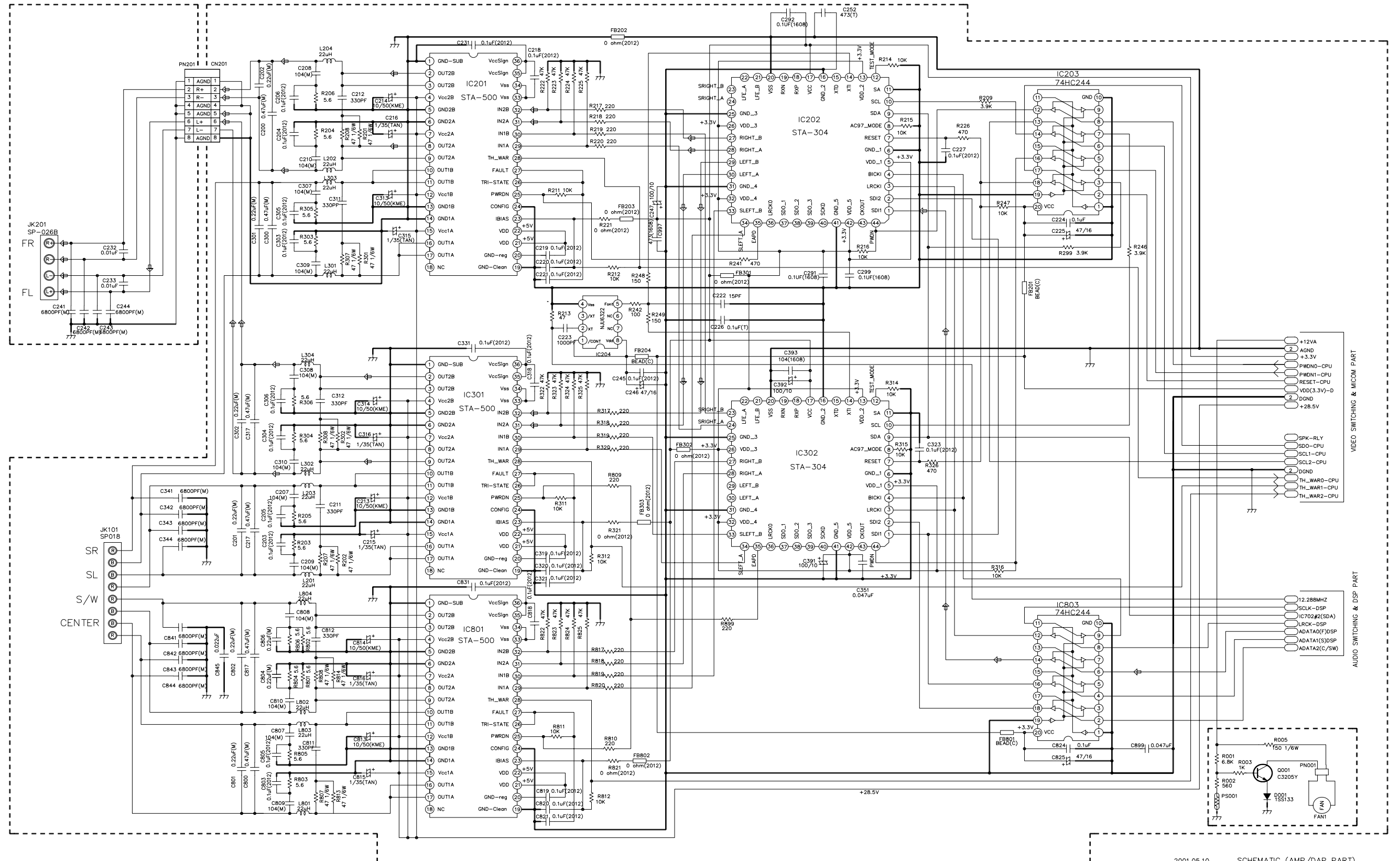

2001.05.10 SCHEMATIC (AMP/DAP PART)  
DA-3520  
SI2909

# DSP(DIGITAL AUDIO PROCESSING)SCHEMATIC DIAGRAM

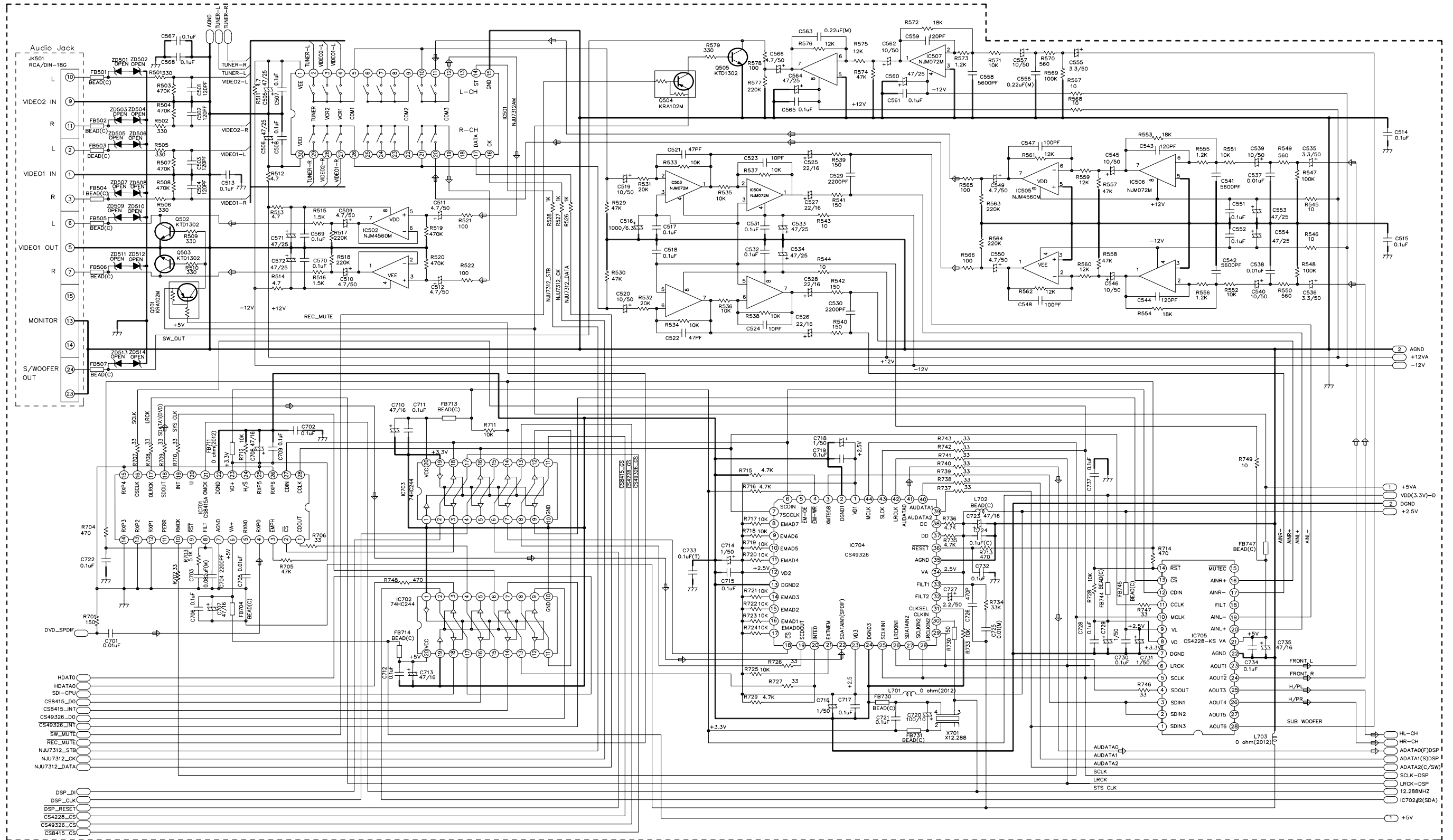

2001.05.05 SCHEMATIC (AUDIO SWITCHING & DSP PART)

DA-3520  
SI2922

# PRINTED CIRCUIT DIAGRAMS

## • MAIN P.C. BOARD(SOLDER SIDE)

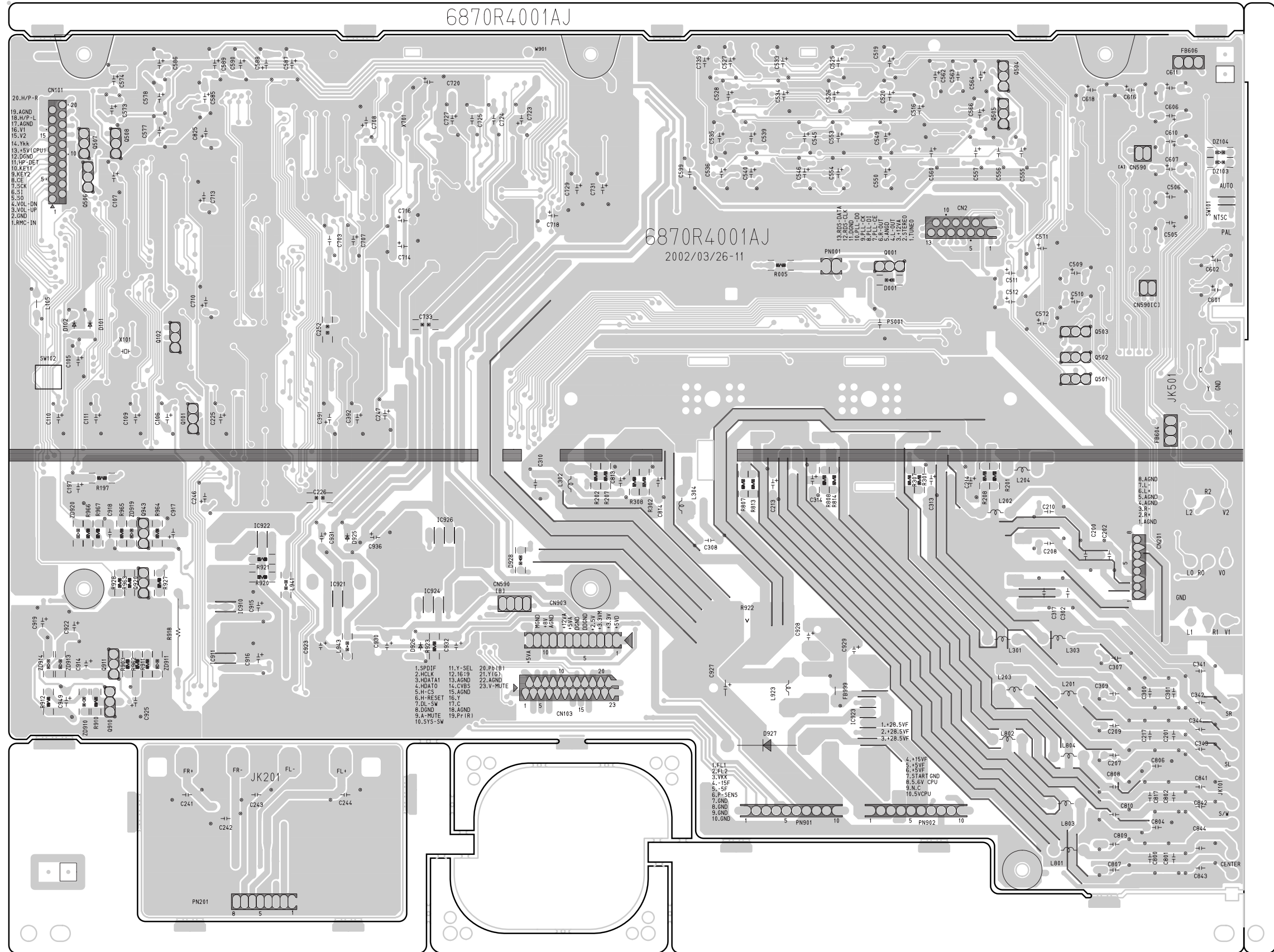

• MAIN P.C. BOARD(COMPONENT SIDE)

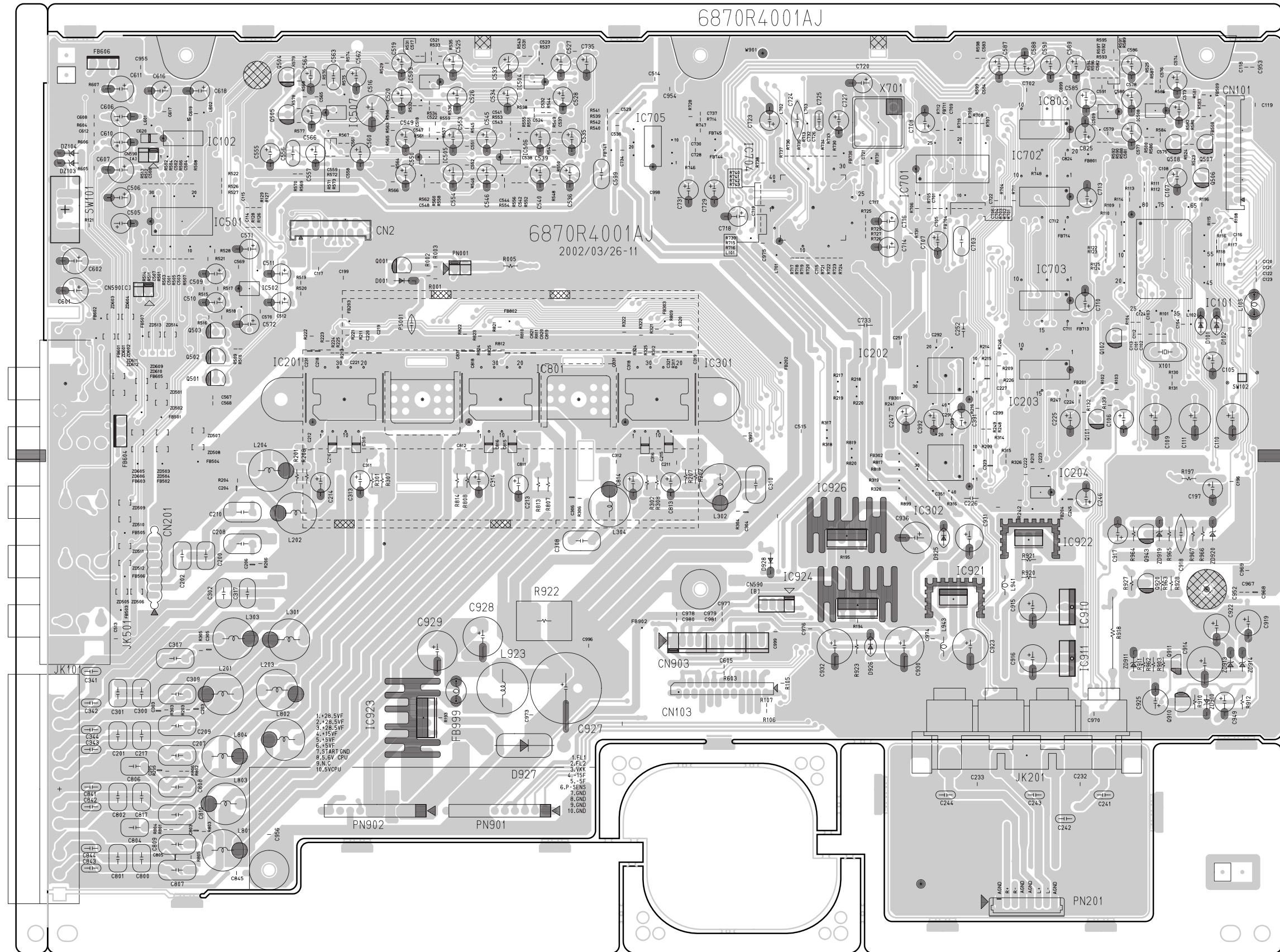

• MAIN/FRONT P.C. BOARD(SOLDER SIDE)

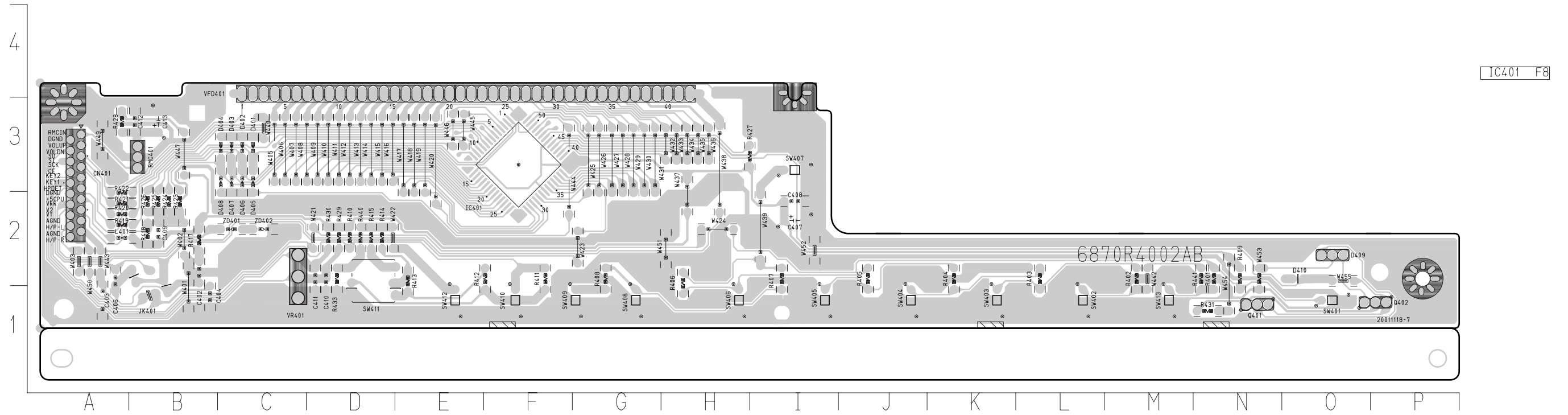

• MAIN/FRONT P.C. BOARD(COMPONENT SIDE)

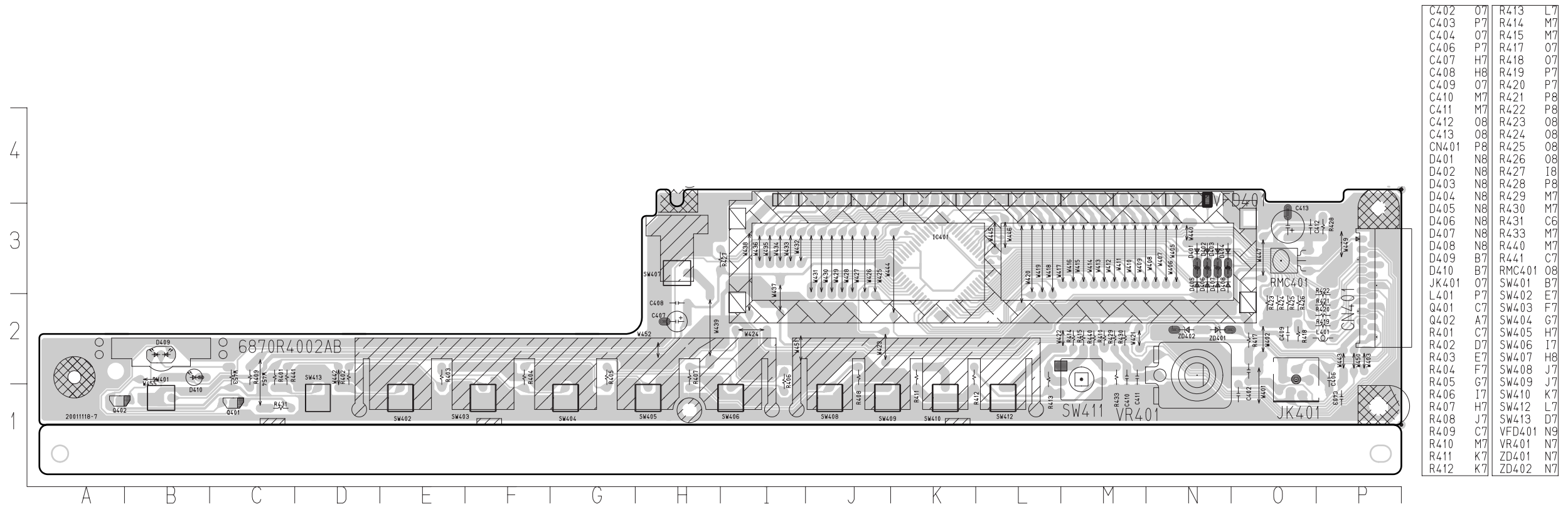

• POWER P.C. BOARD

**NOTE: Warning**  
 Parts that are shaded are critical With respect to risk of fire or electrical shock.

**NOTE:**  
 1. Shaded(■) parts are critical for safety. Replace only with specified part number.  
 2. Voltages are DC-measured with a digital voltmeter during Play mode.

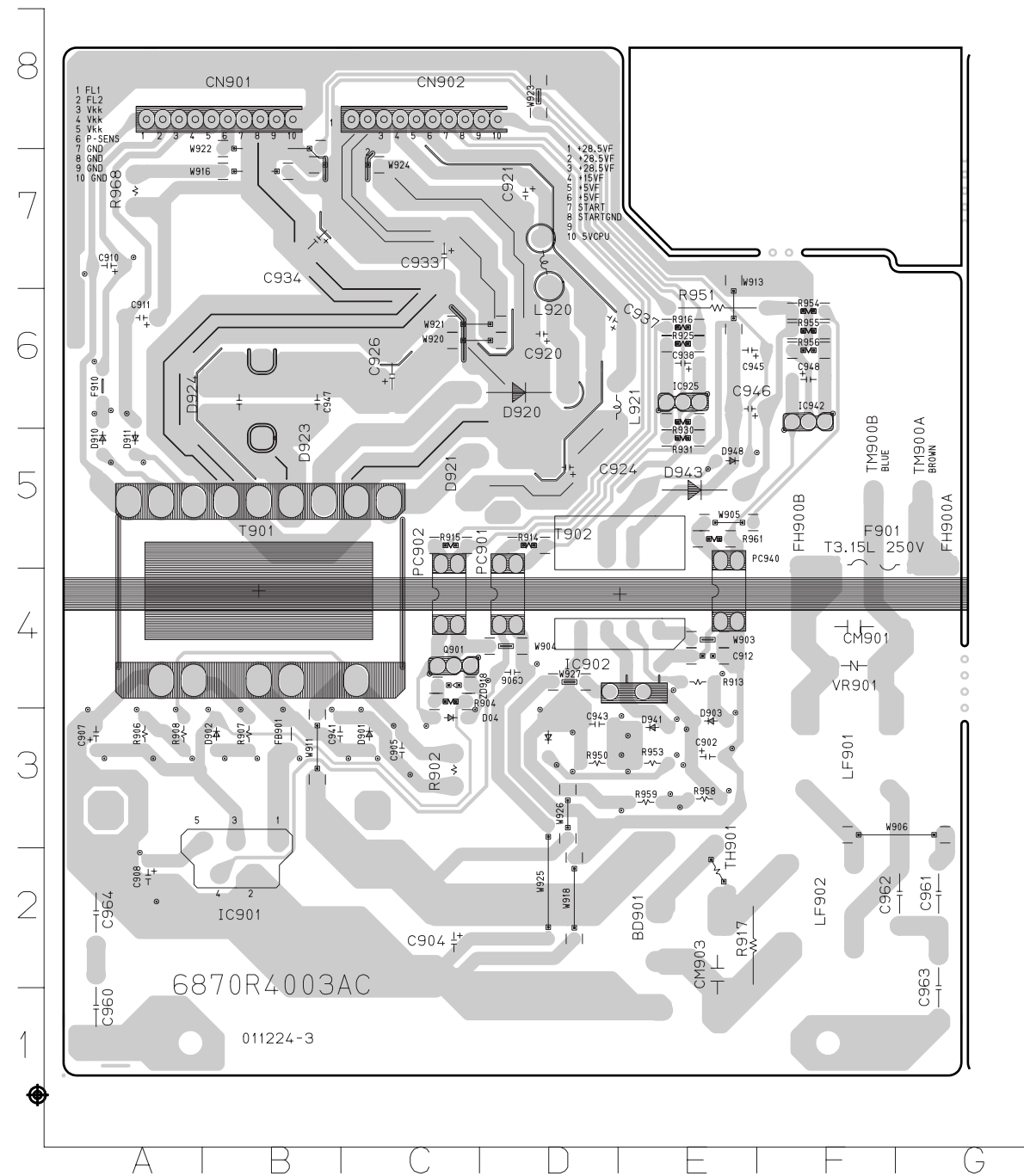

BD901	E2	F910	A6
C902	E3	FB901	B3
C904	C2	FH900A	G5
C905	C3	FH900B	F5
C906	D4	IC901	B3
C907	A3	IC902	E3
C908	A2	IC925	E6
C910	A7	IC942	F6
C911	A6	L920	D7
C912	E4	L921	D6
C920	D6	LF901	F3
C921	D7	LF902	F2
C924	D5	PC901	D5
C926	C6	PC902	C5
C933	C7	PC940	E5
C934	B7	Q901	C4
C937	D6	R902	C3
C938	E6	R904	C4
C941	B3	R906	A3
C943	D3	R907	B3
C945	E6	R908	A3
C946	E6	R913	E4
C947	B6	R914	D5
C948	F6	R915	C5
C960	A1	R916	E6
C961	G2	R917	E2
C962	G2	R925	E6
C963	G1	R930	E6
C964	A2	R931	E5
CM901	F4	R950	D3
CM903	E2	R951	E6
CN901	B8	R953	E3
CN902	C8	R954	F6
D04	C3	R955	F6
D901	C3	R956	F6
D902	B3	R958	E3
D903	E3	R959	E3
D904	J3	R961	E5
D910	A5	R968	A7
D911	A5	T901	B4
D920	D6	T902	E4
D921	C5	TH901	E2
D923	B6	TM900A	G5
D924	B6	TM900B	F5
D941	E3	VR901	F4
D943	E5	ZD918	C4
D948	E5	ZD993	K3

# SECTION 3. DVD PART

## ELECTRICAL TROUBLESHOOTING GUIDE

### 1. $\mu$ -COM Circuit

#### A. Open/Close abnormal

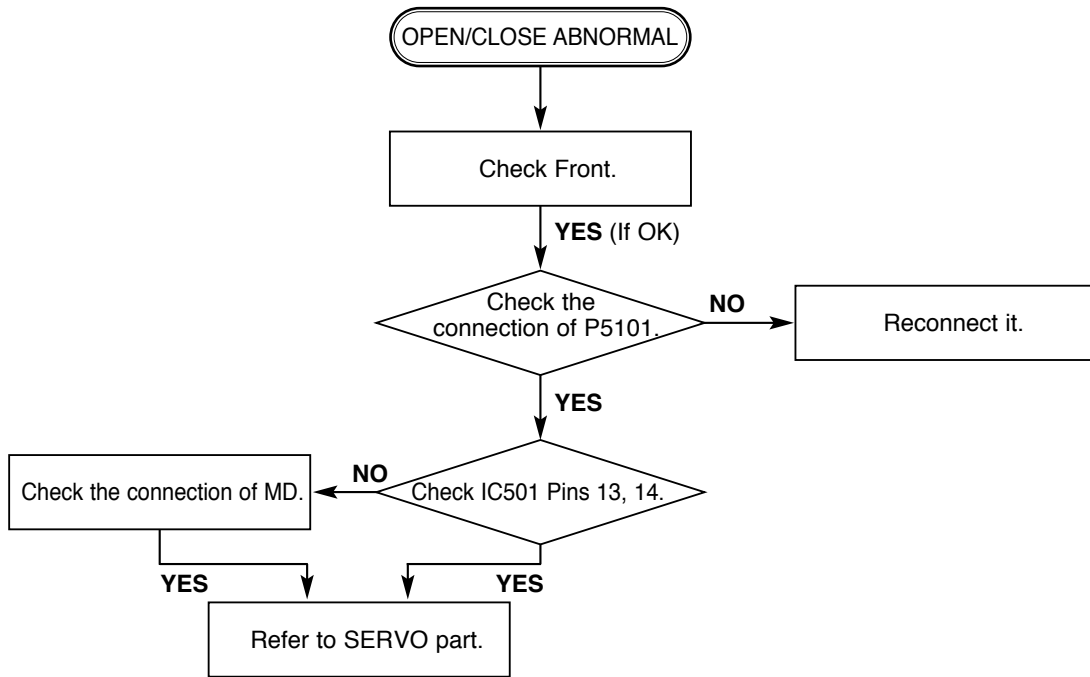

#### B. Video abnormal

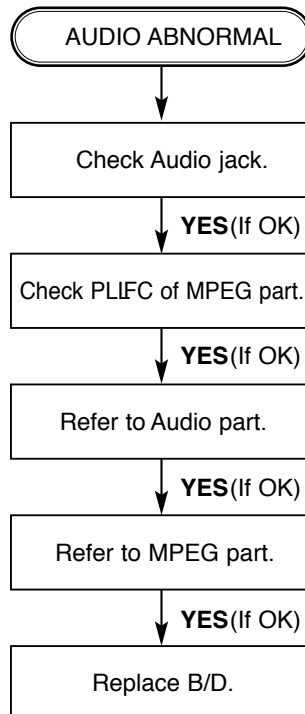



### C. Picture abnormal

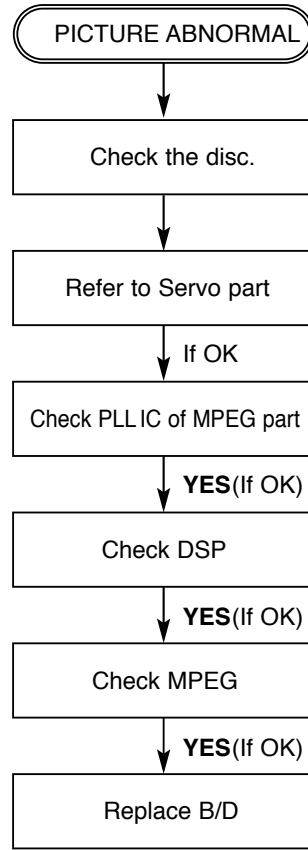

### C. Disc Error

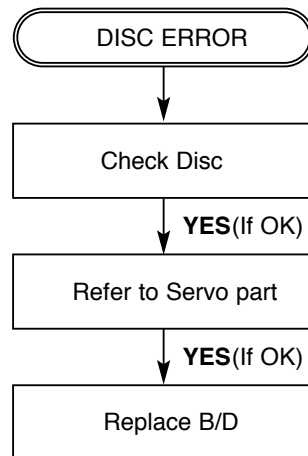

## 2. MPEG Circuit

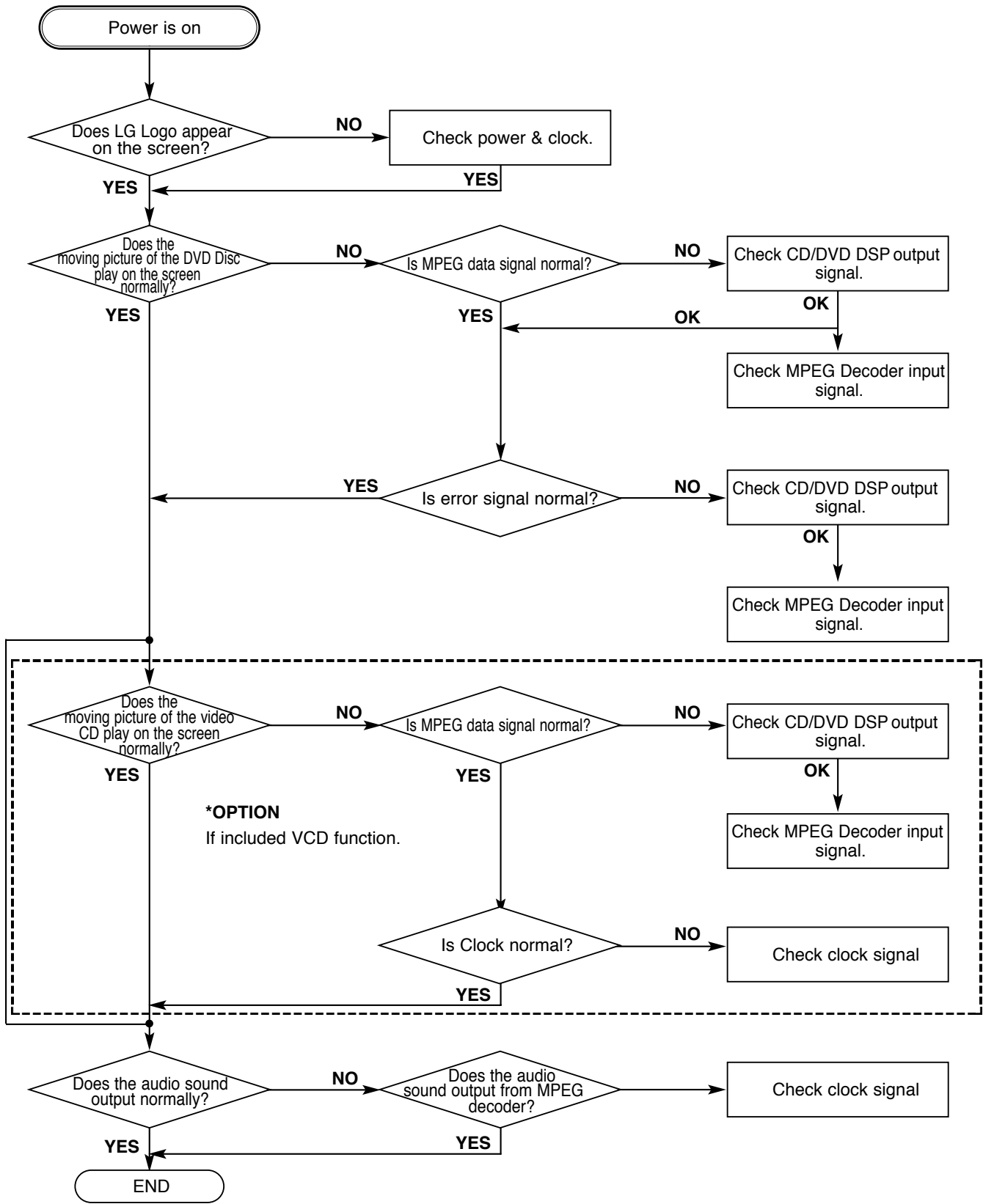

### 3. RF/Servo Circuit

A.

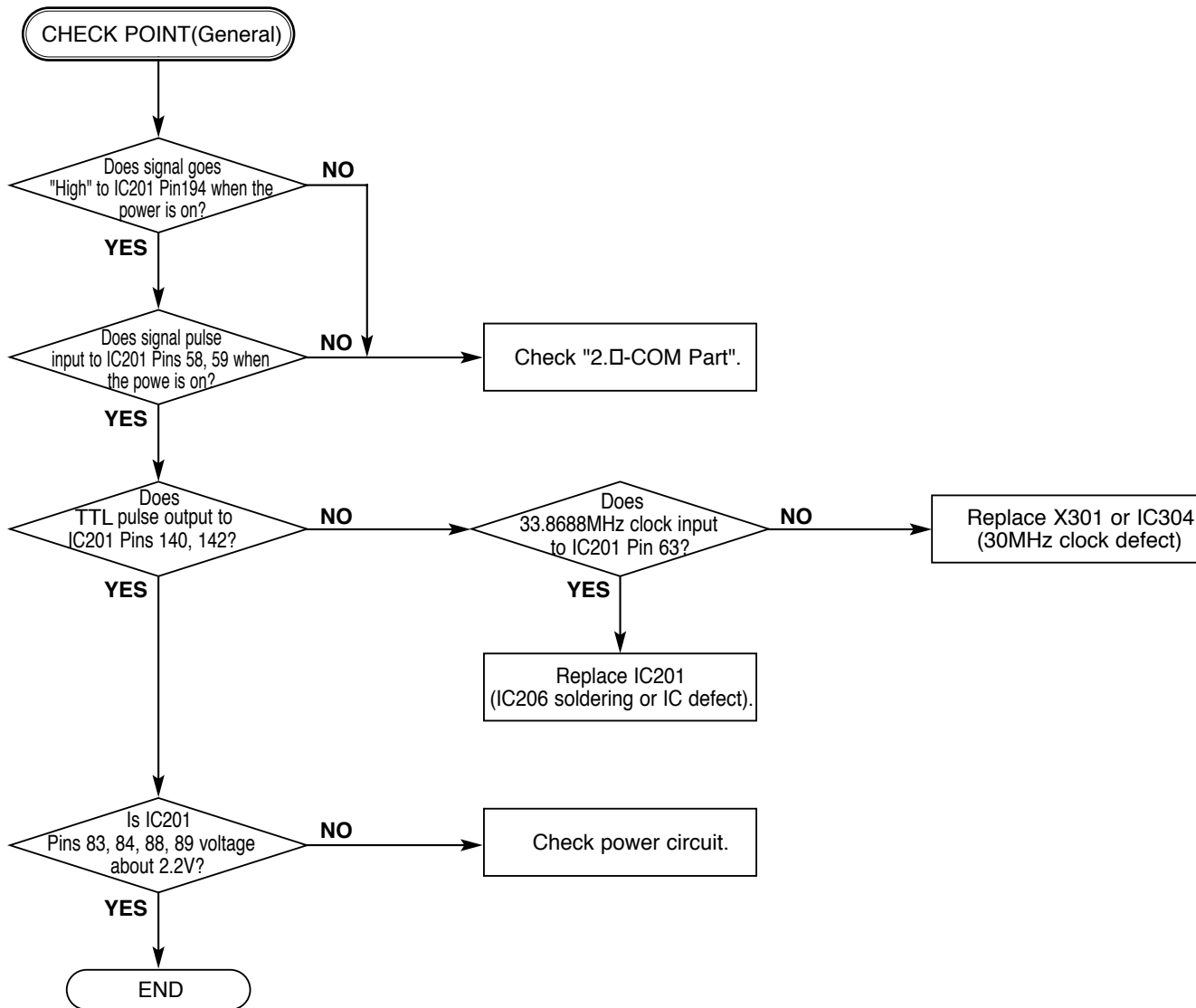

**B**

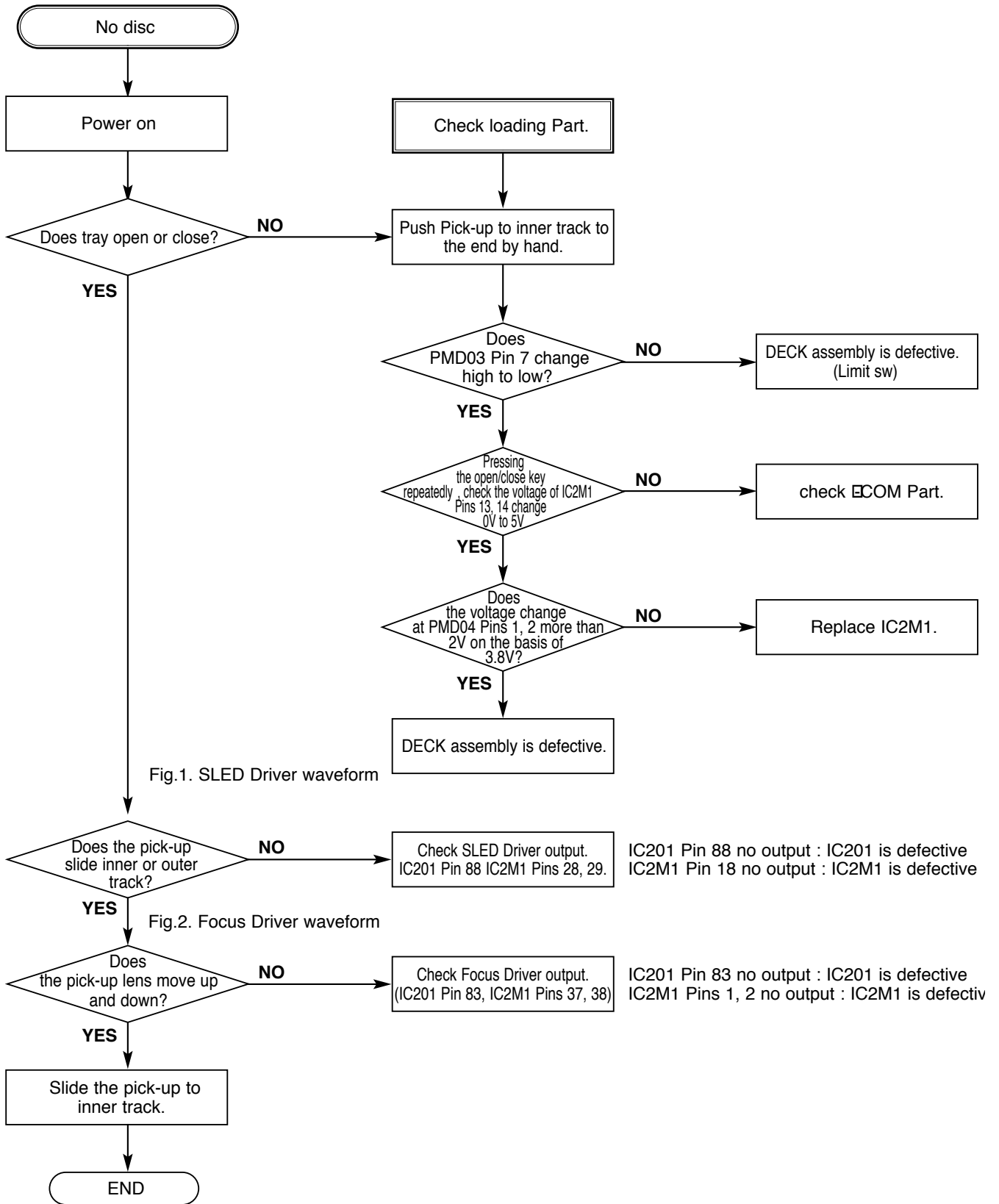

C.

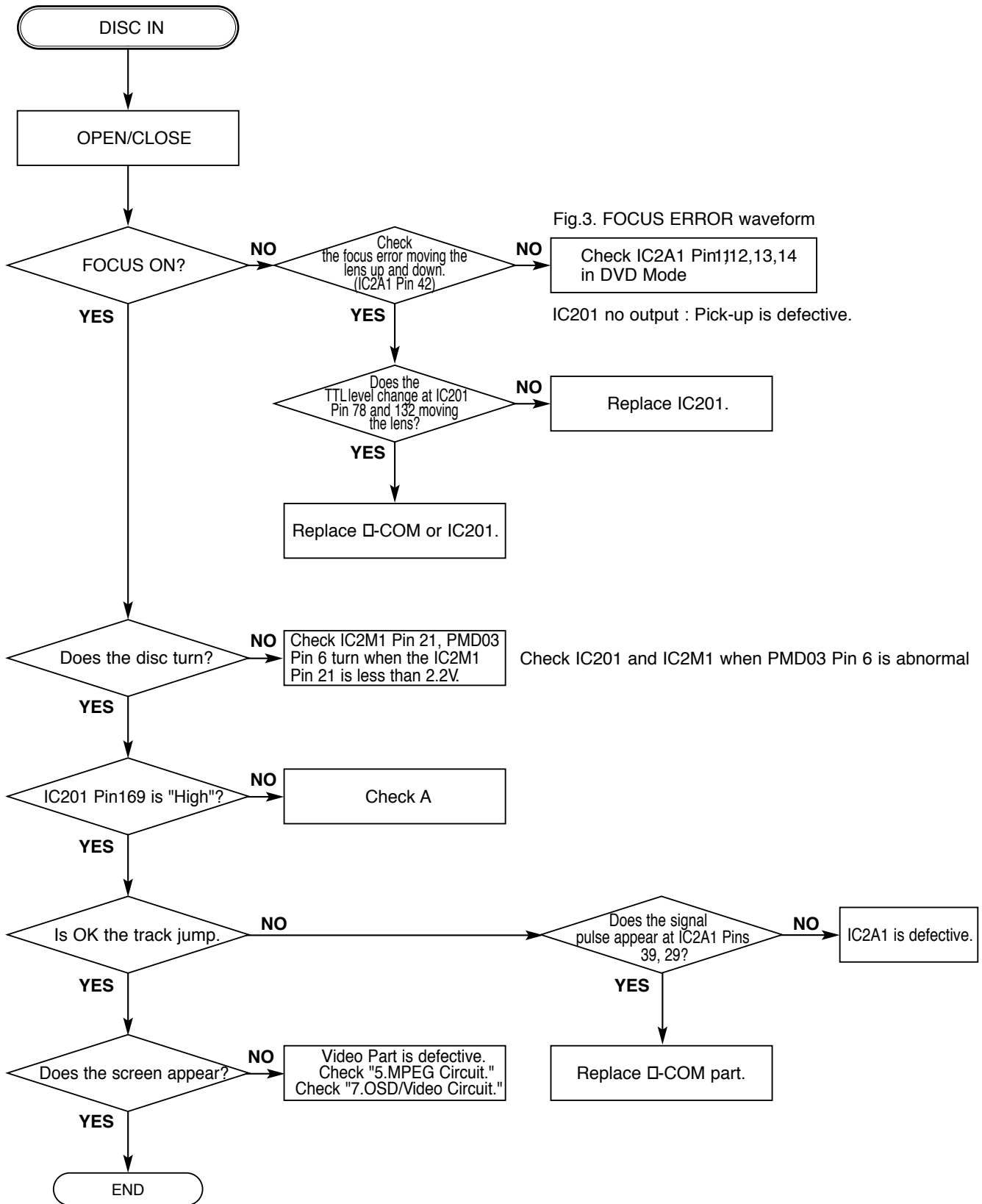

**D.**

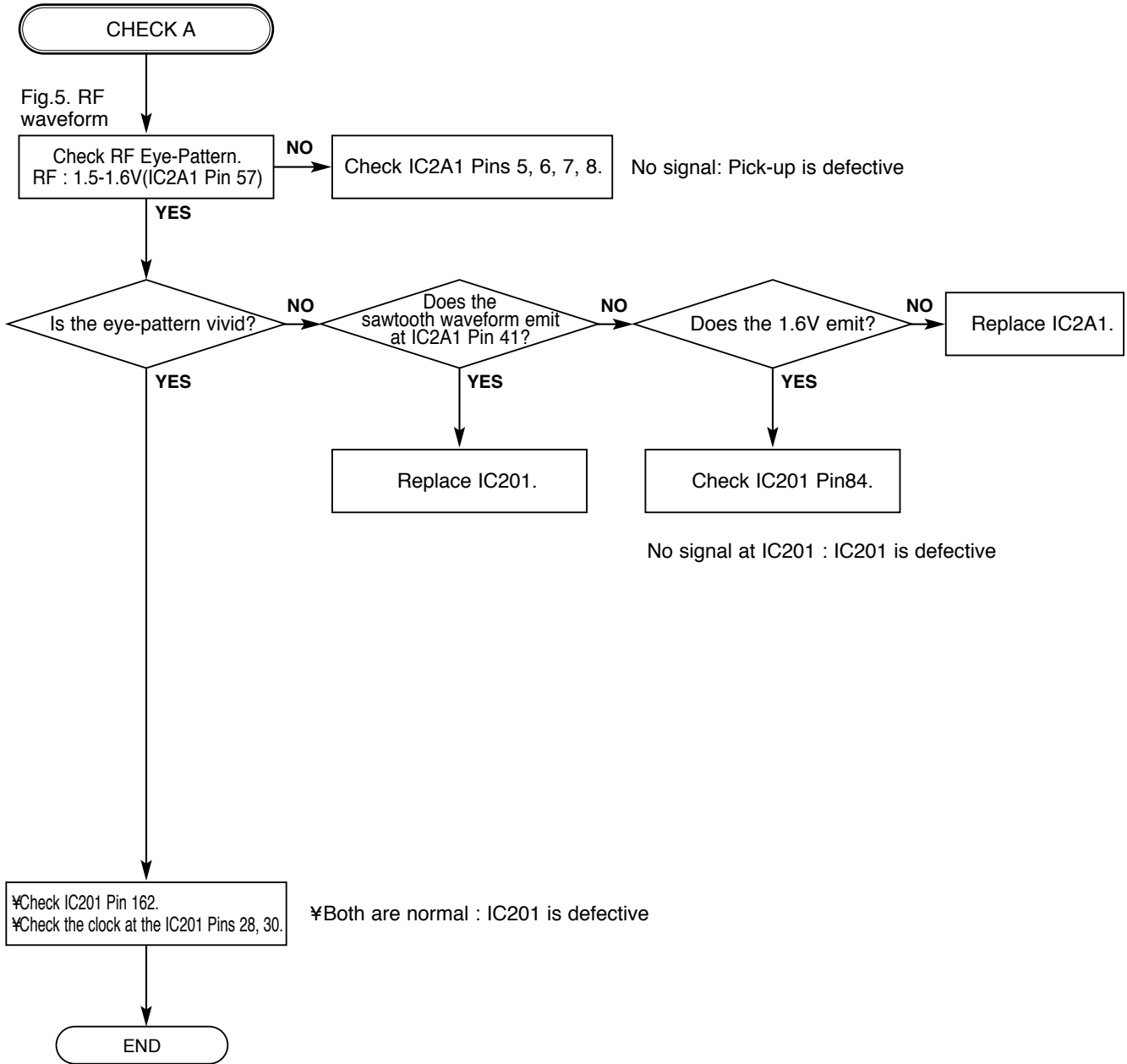

# BLOCK DIAGRAMS

## 1. RF/CD DSP/DVD DSP/DVD SERVO Block Diagram

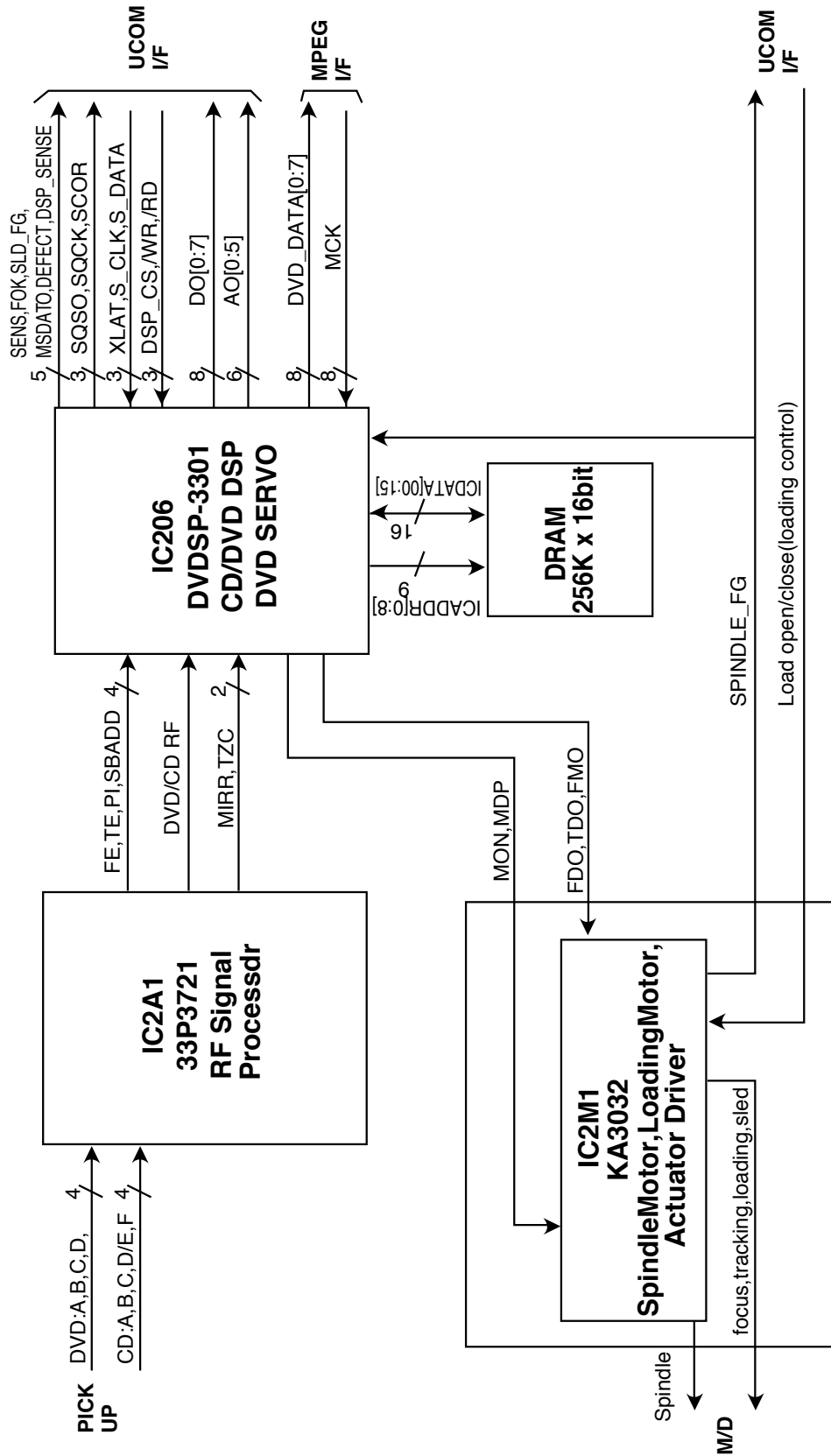

## 2. MPEG Block Diagram

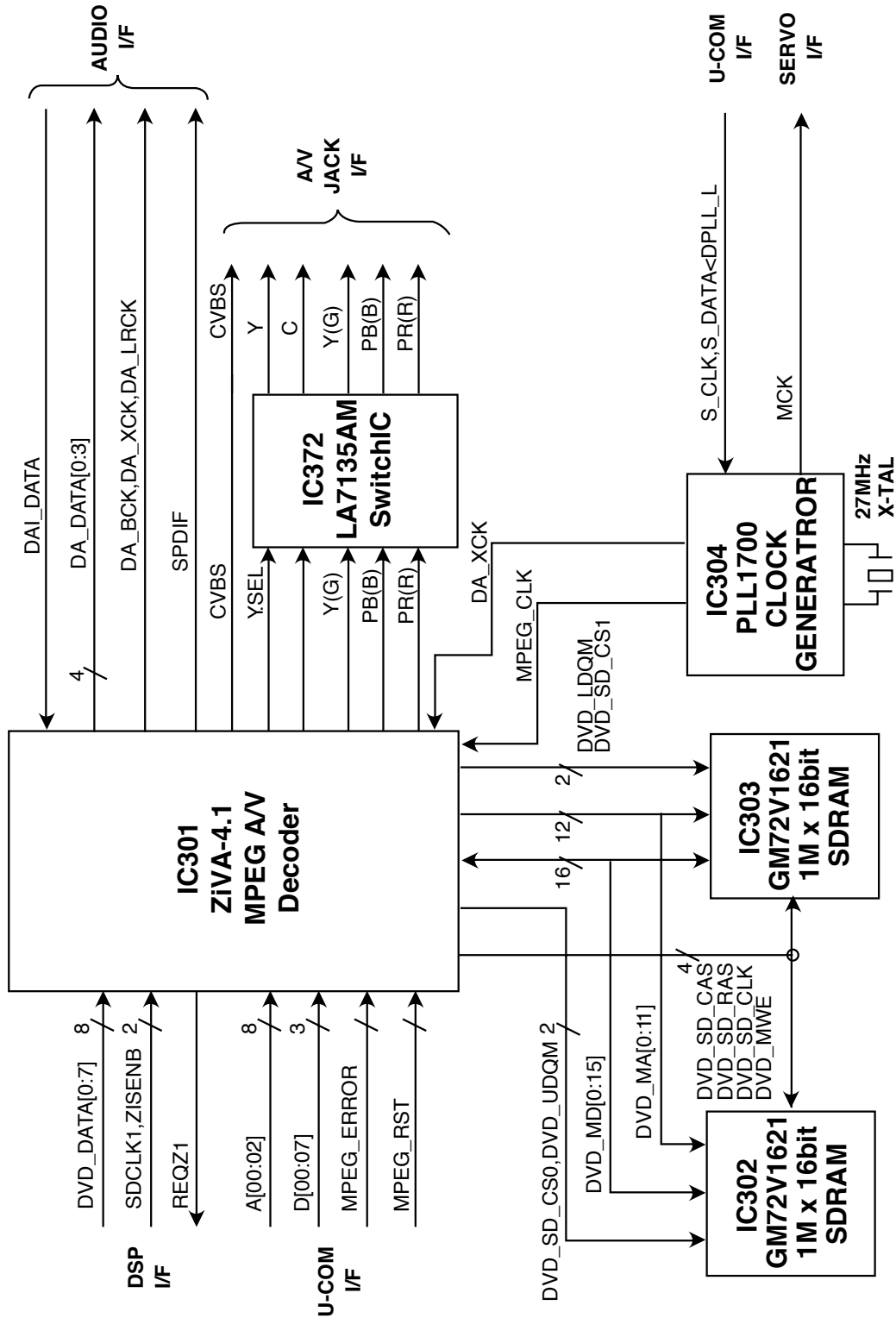



### 3. $\mu$ -COM Block Diagram

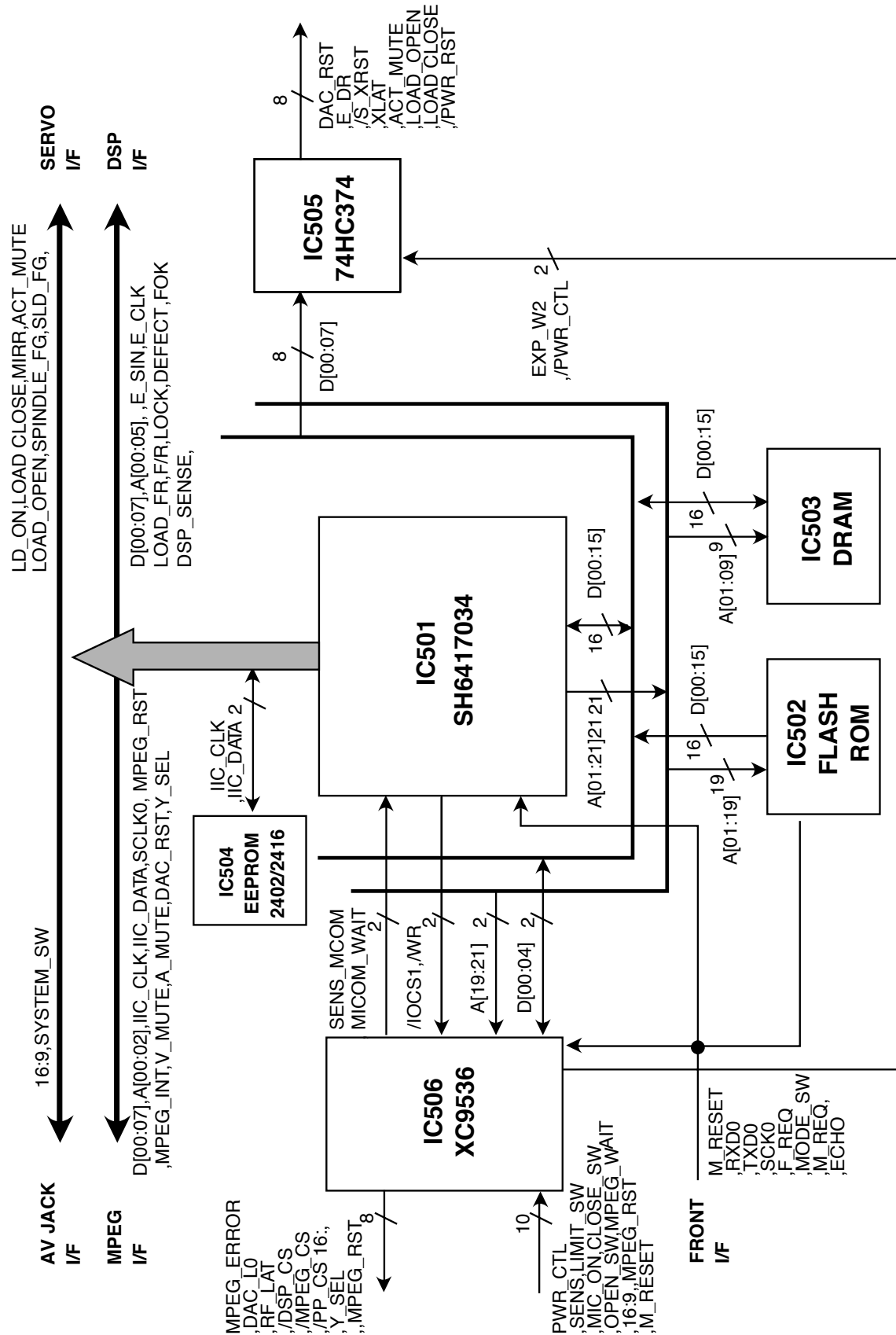

# SCHEMATIC DIAGRAMS

## • DRIVE & RF SCHEMATIC DIAGRAM

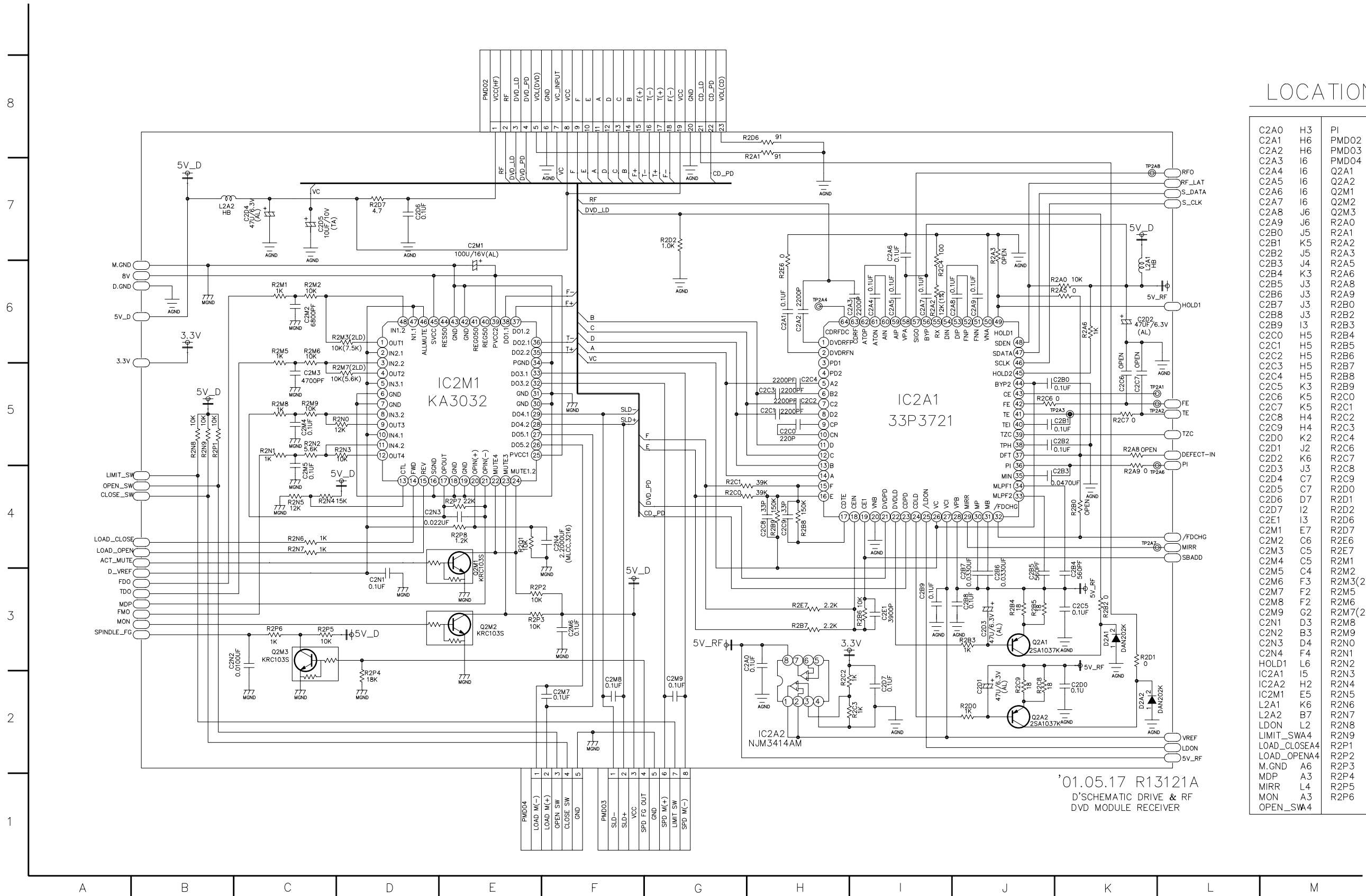

# DVD DSP(DIGITAL SIGNAL PROCESSING)SCHEMATIC DIAGRAM

## LOCATION GUIDE

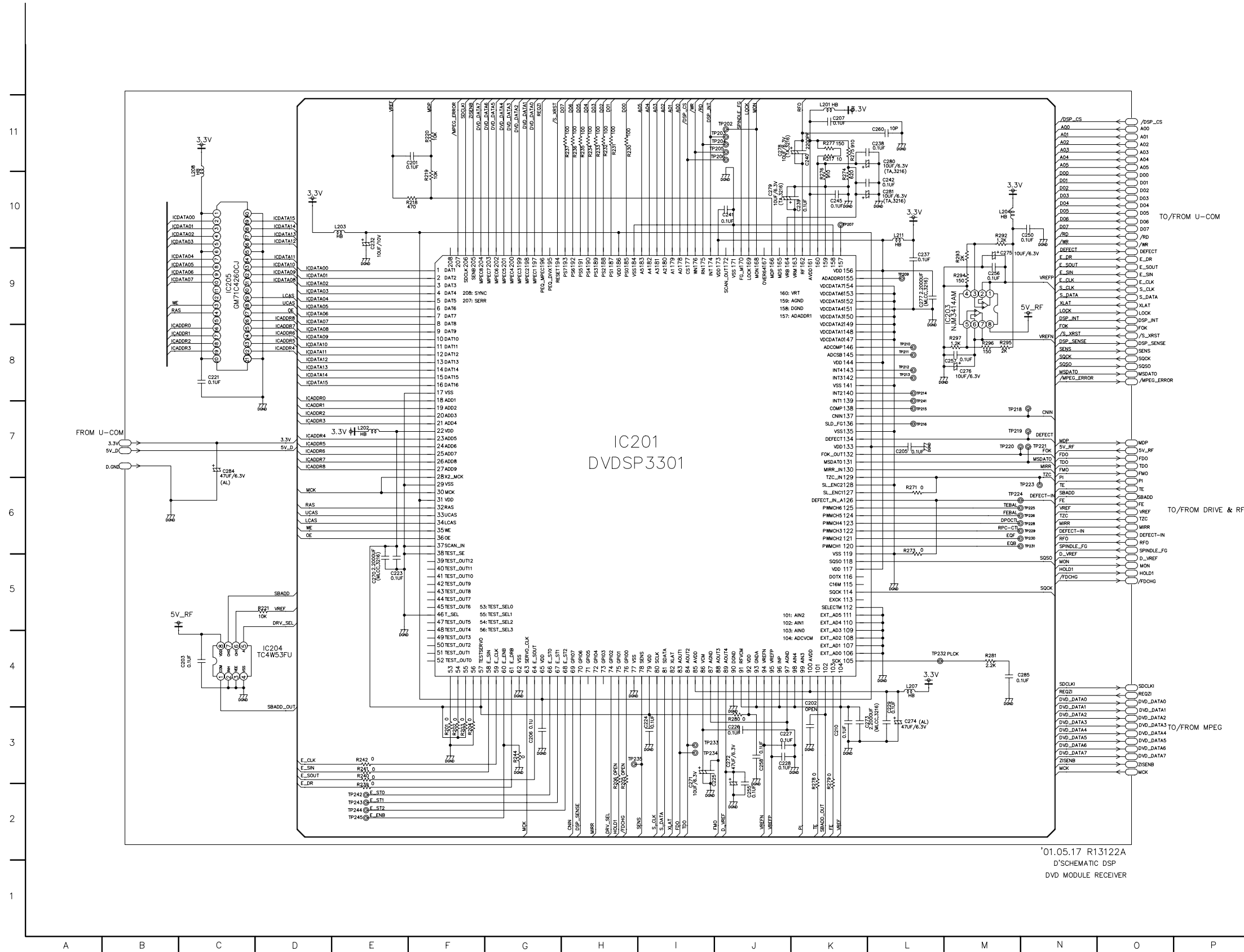

C201	E11	TP202	J11
C202	K4	TP203	I11
C203	C4	TP204	I11
C205	L7	TP205	I11
C206	G3	TP206	I11
C207	K11	TP207	K10
C210	K3	TP209	L9
C221	C8	TP210	L8
C223	E4	TP211	L8
C224	I3	TP212	L8
C225	J2	TP213	L8
C226	J3	TP214	L8
C227	J3	TP215	L7
C228	J3	TP216	L7
C229	L3	TP218	M7
C232	E9	TP219	M7
C237	L9	TP220	M7
C239	K10	TP221	N7
C240	K11	TP224	M6
C241	J10	TP225	N6
C242	L10	TP226	N6
C245	K10	TP228	N6
C250	N10	TP229	N6
C255	J2	TP230	N6
C256	M9	TP231	N6
C257	M8	TP232	L4
C258	J3	TP233	I3
C274	L3	TP234	I3
C275	M9	TP235	H3
C276	M8	ZISENB	F11
C277	L9	ZISENB	O3
C278	J11	ZISENB	O3
C280	L11		
C281	L10		
C284	C7		
C285	M4		
L201	K11		
L202	E7		
L203	E10		
L204	M10		
L207	L4		
L208	C10		
L211	L10		
R201	F3		
R202	F3		
R203	F3		
R204	F3		
R205	H2		
R206	H2		
R217	K11		
R218	E10		
R219	F10		
R220	F11		
R221	D5		
R230	H11		
R231	H11		
R232	H11		
R233	H11		
R234	H11		
R235	H11		
R236	H11		
R237	H11		
R239	E2		
R240	E3		
R241	E3		
R242	E3		
R244	O3		
R271	L6		
R273	L6		
R274	K10		
R275	K11		
R276	K10		
R277	K11		
R278	K2		
R279	K2		
R280	J3		
R281	M4		
R293	M10		
R293	M9		
R295	M8		
R296	M8		
R297	M8		

'01.05.17 R13122A  
D'SCHEMATIC DSP  
DVD MODULE RECEIVER

# μ-COM SCHEMATIC DIAGRAM

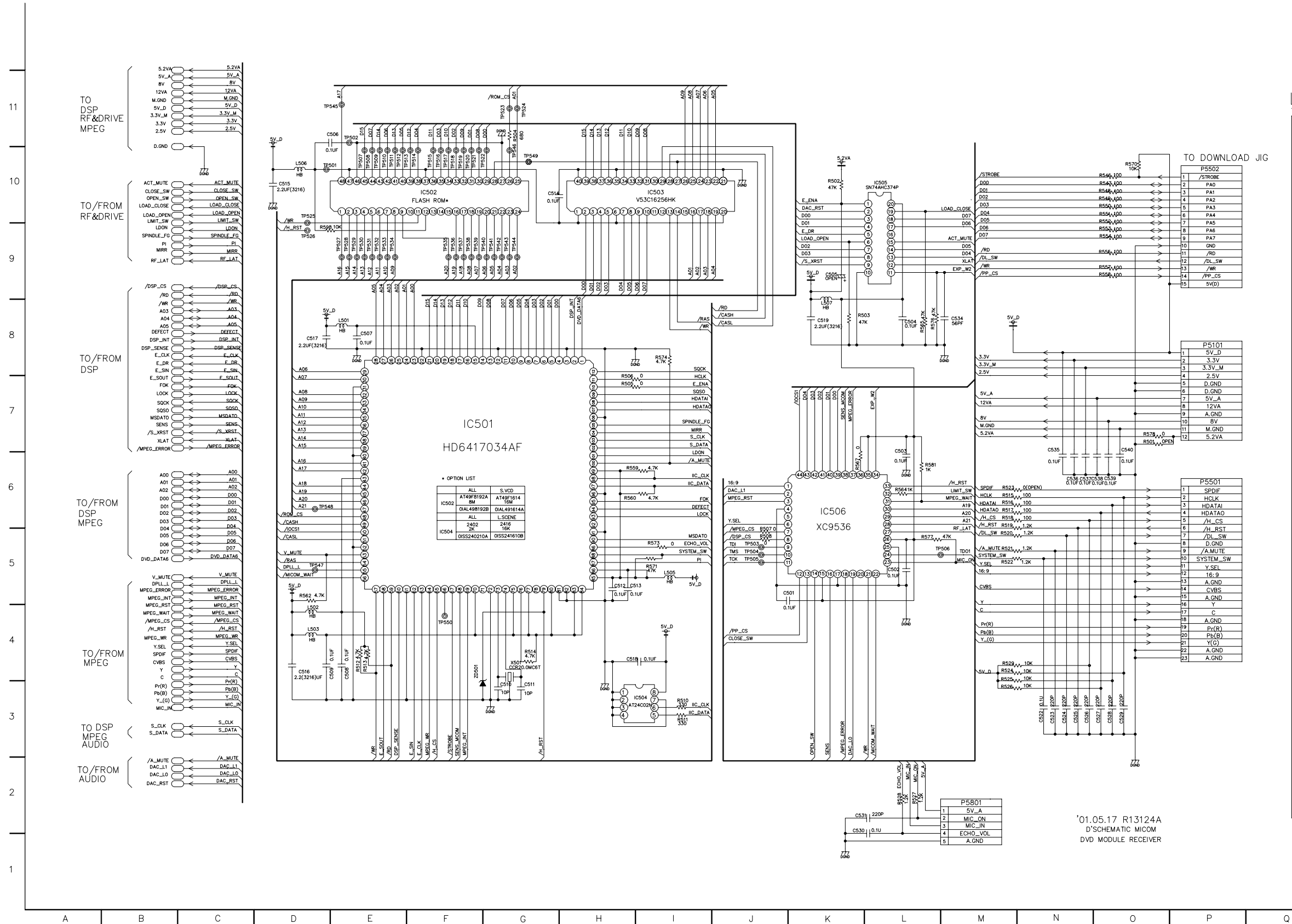

## LOCATION GUIDE

C501	J5	R557	O9
C502	L5	R558	O9
C503	L6	R559	H6
C504	L8	R560	H6
C505	K9	R562	D5
C506	D11	R564	L6
C507	E8	R565	L8
C508	E4	R567	K6
C509	E4	R570	O10
C510	G3	R571	I5
C511	G3	R573	I5
C512	H5	R574	I8
C513	H5	R576	L8
C514	G10	R577	L5
C515	D10	R578	O7
C516	D4	R581	L6
C517	D8	R598	D9
C518	H4	TP501	D10
C519	K8	TP502	E11
C522	N3	TP503	J5
C523	N3	TP504	J5
C524	N3	TP505	J5
C525	N3	TP506	L5
C526	N3	TP507	E10
C527	O3	TP508	E10
C528	O3	TP509	E10
C529	O3	TP510	E10
C530	K2	TP511	E10
C531	K2	TP512	E10
C534	M8	TP513	F10
C535	N7	TP514	F10
C536	N6	TP515	F10
C537	N6	TP516	F10
C538	N6	TP517	F10
C539	O6	TP518	F10
C540	O7	TP519	F10
IC501	F7	TP520	F10
IC502	F10	TP521	F10
IC503	I10	TP522	G11
IC504	H3	TP523	G11
IC505	L10	TP524	G11
IC506	K6	TP525	D10
L501	E8	TP526	D9
L502	D4	TP527	E9
L503	D4	TP528	E9
L505	I5	TP529	E9
L506	D10	TP530	E9
L507	K8	TP531	E9
P5501	P8	TP532	E9
P5502	P10	TP534	E9
P5801	M2	TP535	F9
R501	O7	TP536	F9
R502	K10	TP537	F9
R503	K8	TP538	F9
R504	G11	TP539	F9
R505	H7	TP540	G9
R506	H7	TP541	G9
R507	J5	TP542	G9
R508	J5	TP543	G9
R510	I3	TP544	G9
R511	I3	TP545	D11
R512	E4	TP546	D10
R513	E4	TP547	D5
R514	C4	TP548	D6
R515	M6	TP549	G10
R516	M6	TP550	F4
R517	M6	ZD501	F4
R518	M6		
R519	M6		
R520	M5		
R521	M5		
R522	M5		
R523	M6		
R524	M4		
R525	M4		
R526	M3		
R527	L2		
R528	L2		
R529	M4		
R546	O10		
R547	O10		
R548	O10		
R549	O10		
R550	O10		
R551	O10		
R552	O10		
R553	O9		
R554	O9		
R555	O9		

'01.05.17 R13124A  
D'SCHEMATIC MICOM  
DVD MODULE RECEIVER

# MPEG SCHEMATIC DIAGRAM

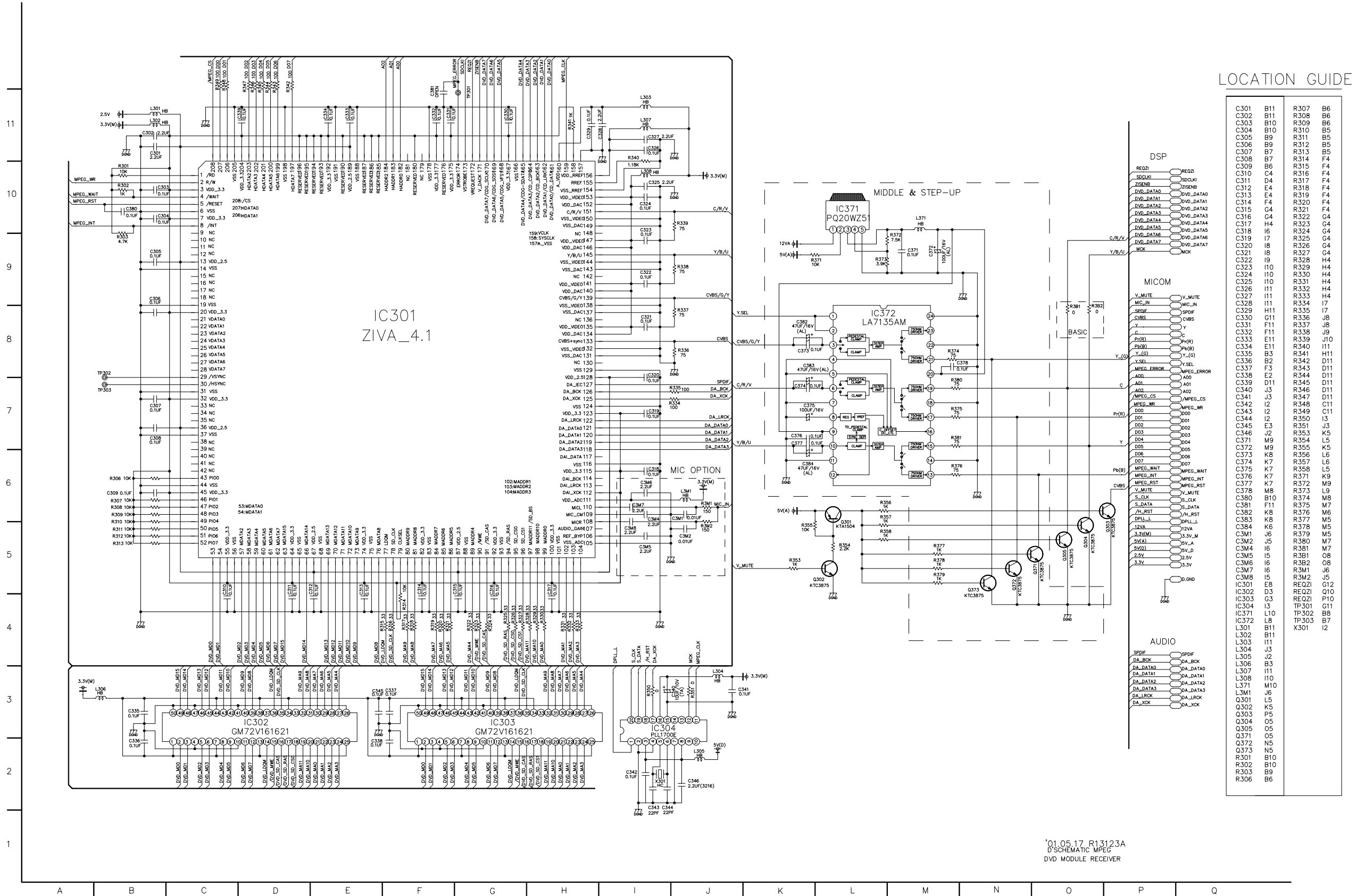

• WAVEFORMS

1)

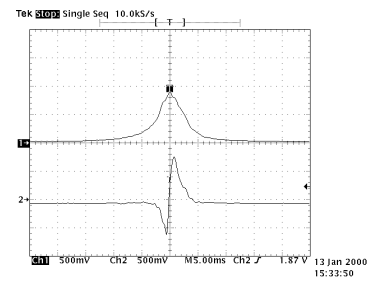

IC2A1 Pin 42, Focus Error  
IC2A1 Pin 36, Pi

2)

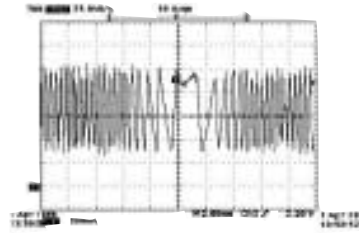

IC2A1 Pin 41  
Tracking Error

3)

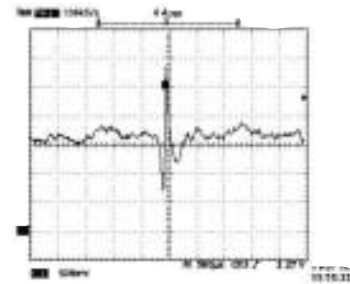

IC2A1 Pin 41  
VBR TRACKING Error

1)

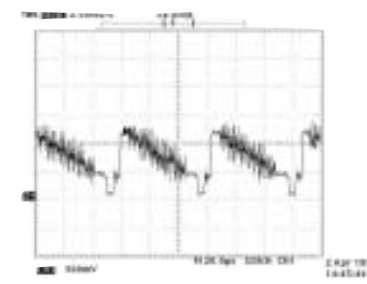

IC301 Pin 133, Composite

2)

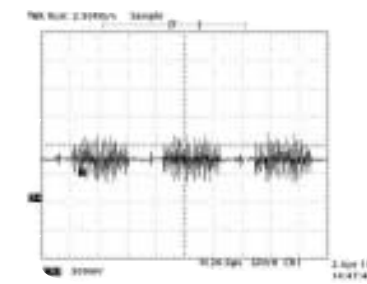

IC301 Pin 151, Chrominance  
(Super video out Mode)

3)

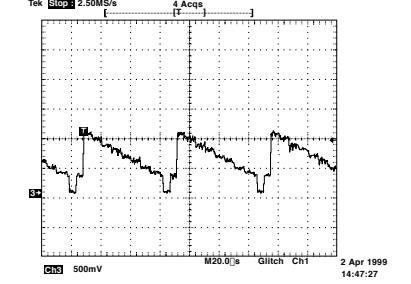

IC301 Pin 145, Luminance  
(Super video out Mode)

4)

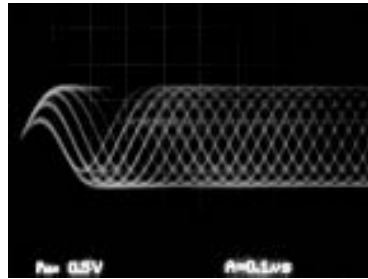

IC2A1 Pin 57  
RF

5)

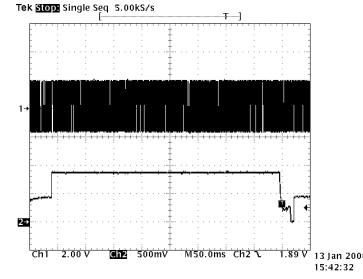

IC201, Pin 88, SLED Drive(FMO)  
IC201, Pin 18 SLED FG

6)

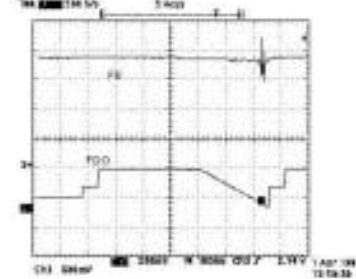

IC2A1 Pin 42, Focus Error(Focus Search)  
IC2A1 Pin 83, Focus Drive(FDO)

4)

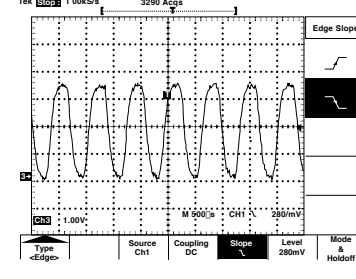

IC301 Pin 159,  
MPEG Clock(27MHz)

5)

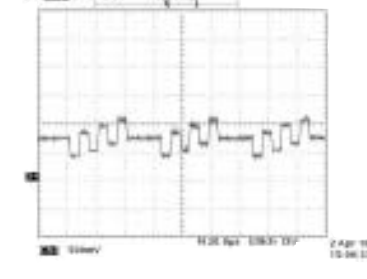

IC301 Pin 145,  
Component Pb

6)

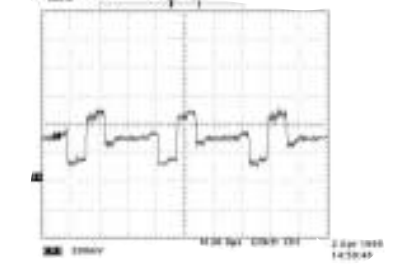

IC301 Pin 151,  
Component Pr

7)

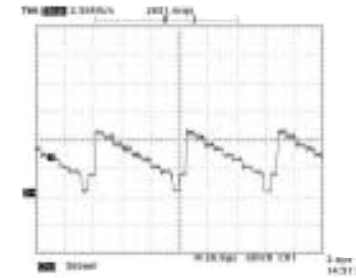

IC301 PIN 139,  
COMPONENT Y

# PRINTED CIRCUIT DIAGRAM

## • DVD P.C. BOARD(SOLDER SIDE)

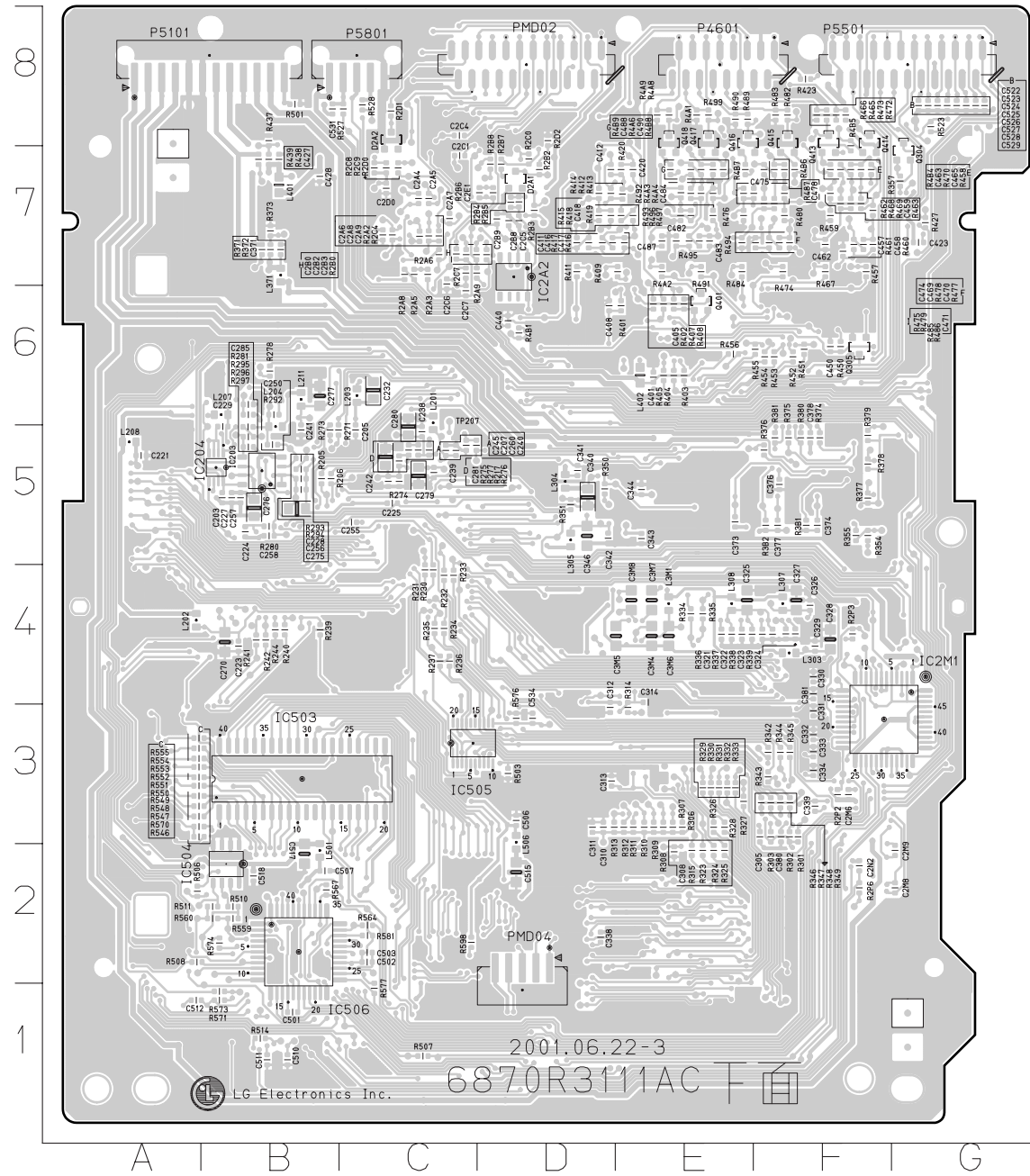

C203	B5	C308	E2	C450	F6	L207	B6	R292	B5	R333	E3	R438	B7	R4B1	D6
C205	C5	C310	D3	C457	F7	L208	A5	R293	B5	R334	E4	R439	B7	R4B4	F7
C207	C5	C311	D3	C458	F7	L211	B6	R294	B5	R335	E4	R450	F6	R4B5	F7
C221	A5	C312	D3	C459	F7	L303	F4	R295	B5	R336	E4	R451	F6	R4B6	F7
C223	B4	C313	D3	C462	F7	L304	D5	R296	B5	R337	E4	R452	F6	R4B7	E7
C224	B5	C314	E4	C463	F7	L305	D5	R297	B5	R338	F4	R453	F6	R4B8	E7
C225	C5	C321	E4	C465	F7	L307	F4	R2A2	C7	R339	F4	R454	F6	R4B9	E7
C227	B5	C322	E4	C469	F7	L308	E4	R2A3	C7	R342	F3	R455	F6	R501	B8
C228	B5	C323	F4	C470	F7	L371	B7	R2A5	C7	R343	F3	R456	E6	R503	D3
C229	B5	C324	F4	C471	F7	L3M1	E4	R2A6	C7	R344	F3	R457	F7	R506	A2
C232	C6	C325	E4	C474	E7	L401	B7	R2A8	C7	R345	F3	R458	F7	R507	C1
C238	C5	C326	F4	C475	F7	L402	E6	R2A9	C7	R346	F3	R459	F7	R508	A2
C239	C5	C327	F4	C478	F7	L501	B2	R2B0	D7	R347	F3	R460	F7	R510	B2
C240	C5	C328	F4	C482	E7	L506	D3	R2B2	D7	R348	F3	R461	F7	R511	B2
C241	B5	C329	F4	C483	E7	P4601	E8	R2B3	D7	R349	F3	R462	F7	R514	B1
C242	C5	C330	F4	C484	E7	P5101	B8	R2B4	D7	R350	D5	R463	F7	R523	G8
C245	C5	C331	F3	C487	E7	P5501	G8	R2B5	D7	R351	D5	R465	F8	R527	C8
C250	B6	C332	F3	C488	E7	P5801	C8	R2B6	D7	R354	F5	R466	F8	R528	C8
C255	C5	C333	F3	C490	E7	PMD02	D8	R2B7	D7	R355	F5	R467	F7	R546	A3
C256	B5	C334	F3	C501	B1	PMD04	D1	R2B8	D7	R357	G7	R468	F7	R547	A3
C257	B5	C338	D2	C502	C2	Q304	G7	R2C0	D7	R371	B7	R469	F7	R548	A3
C258	B5	C339	F3	C503	C2	Q305	F6	R2C4	C7	R372	B7	R470	F7	R549	A3
C260	C5	C340	D5	C506	D3	Q401	E6	R2C7	C7	R373	B7	R472	F8	R550	A3
C270	B4	C341	D5	C507	B2	Q413	F8	R2C8	C7	R374	F5	R473	F8	R551	A3
C275	B5	C342	D5	C510	B1	Q414	F8	R2C9	C7	R375	F5	R474	F7	R552	A3
C276	B5	C343	E5	C511	B1	Q415	F8	R2D0	C7	R376	F5	R475	E7	R553	A3
C277	B6	C344	E5	C512	A1	Q416	E8	R2D1	C8	R377	F5	R476	E7	R554	A3
C279	C5	C346	D5	C515	D2	Q417	E8	R2D2	D8	R378	F5	R477	F7	R555	A3
C280	C5	C371	B7	C517	B2	Q418	E8	R2P2	F3	R379	F5	R478	F7	R559	B2
C281	C5	C373	E5	C518	B2	R205	B5	R2P3	F4	R380	F5	R479	F7	R560	B2
C285	B6	C374	F5	C522	G8	R206	B5	R2P6	F2	R381	F5	R480	F7	R564	C2
C2A4	C7	C376	F5	C523	G8	R217	C5	R301	F3	R3B1	F5	R482	F8	R567	B2
C2A5	C7	C377	F5	C524	G8	R230	C4	R302	F3	R3B2	F5	R483	F8	R570	A3
C2A6	C7	C378	F5	C525	G8	R231	C4	R303	F3	R401	E6	R484	E7	R571	B1
C2A7	C7	C380	F3	C526	G8	R232	C4	R306	E3	R402	E6	R485	F7	R573	B1
C2A8	C7	C381	F4	C527	G8	R233	C4	R307	E3	R403	E6	R486	F7	R574	B2
C2A9	C7	C3M4	E4	C528	G8	R234	C4	R308	E3	R404	E6	R487	F7	R576	D3
C2B0	C7	C3M5	E4	C529	G8	R235	C4	R309	E3	R405	E6	R489	E8	R577	C1
C2B2	C7	C3M6	E4	C531	B8	R236	C4	R310	E3	R407	E6	R490	E8	R581	C2
C2B3	C7	C3M7	E4	C534	D3	R237	C4	R311	E3	R408	E6	R491	E7	R598	C2
C2B8	D7	C3M8	E4	D2A1	D7	R239	B4	R312	E3	R409	E7	R492	E7	TP207	C6
C2B9	D7	C401	E6	D2A2	C8	R240	B4	R313	D3	R411	D7	R493	E7	TP2A6	B5
C2C1	C7	C405	E6	IC203	B5	R241	B4	R314	E3	R412	D7	R494	E7	TP301	C2
C2C4	C8	C408	D6	IC204	B5	R242	B4	R315	E2	R413	E7	R495	E7	TP503	A2
C2C5	D7	C411	D7	IC2A2	D7	R244	B4	R323	E2	R414	D7	R496	E7	TP504	B2
C2C6	C7	C412	D7	IC2M1	F3	R271	B5	R324	E2	R415	D7	R497	E7	TP505	B2
C2C7	C6	C416	D7	IC503	B3	R273	B5	R325	E2	R416	E7	R499	E8	TP506	C2
C2D0	C7	C417	D7	IC504	B2	R274	C5	R326	E3	R417	D7	R4A1	E8		
C2E1	D7	C418	E7	IC505	C3	R275	C5	R327	E3	R418	D7	R4A2	E7		
C2M6	F3	C420	E7	IC506	B2	R276	C5	R328	E3	R419	E7	R4A3	E7		
C2M8	G2	C423	G7	L201	C6	R277	C5	R329	E3	R420	E7	R4A4	E7		
C2M9	G2	C427	B7	L202	A4	R278	B6	R330	E3	R423	F8	R4A6	E7		
C2N2	F2	C428	B7	L203	C6	R280	B5	R331	E3	R427	G7	R4A8	E8		
C305	F3	C440	D6	L204	B5	R281	B6	R332	E3	R437	B8	R4A9	E8		

• DVD P.C. BOARD(COMPONENT SIDE)

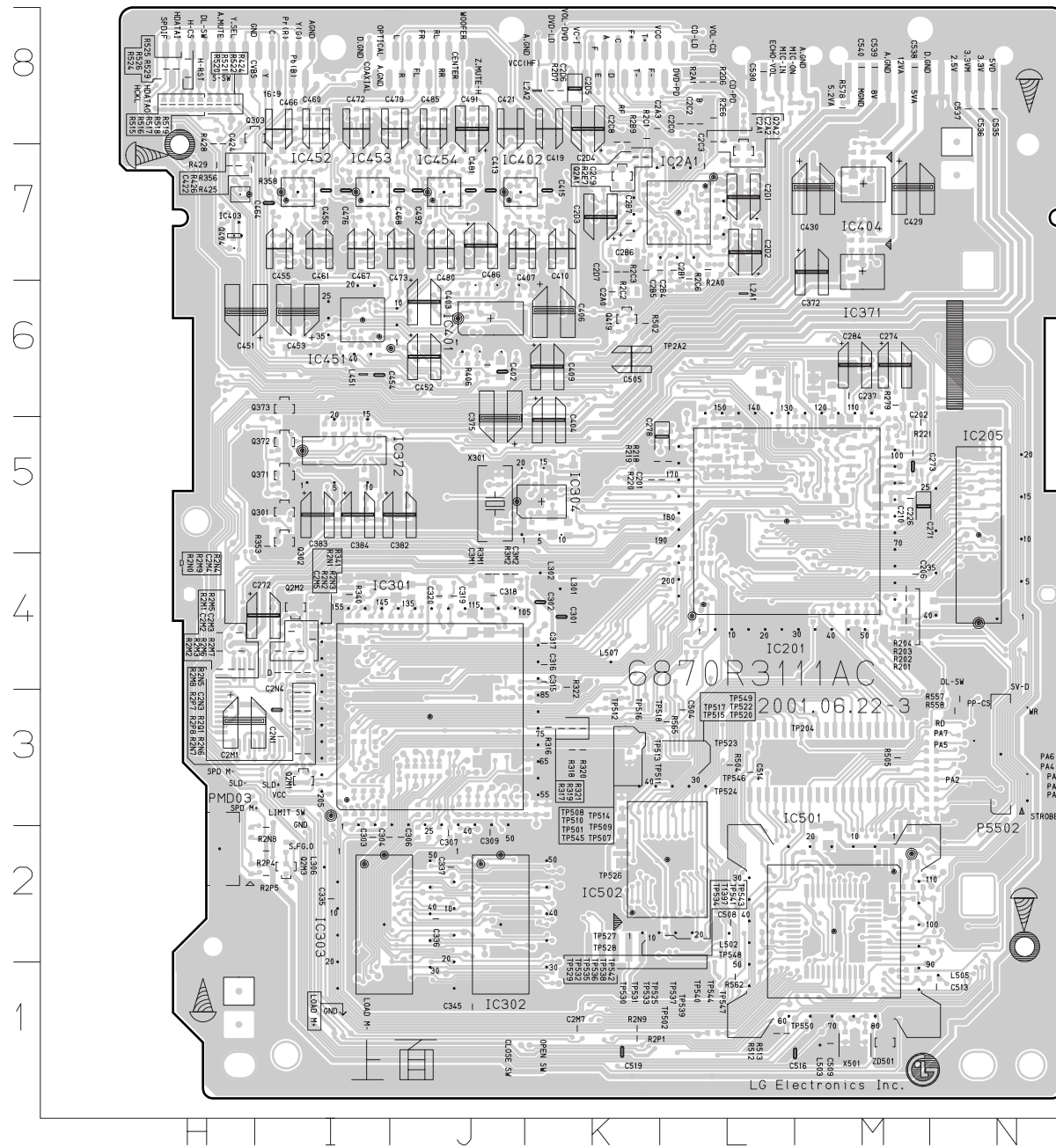

C201	L5	C315	K4	C481	J7	P5502	N3	R2N6	I3	R562	L1	TP509	K3
C202	M5	C316	K4	C485	J8	PMD03	H2	R2N7	I3	R565	L3	TP510	K3
C206	M4	C317	K4	C486	J7	Q2A1	K7	R2N8	I2	R578	M8	TP511	K3
C210	M5	C318	J4	C491	J8	Q2A2	L7	R2N9	K1	TP202	L5	TP512	K3
C226	M5	C319	J4	C492	J7	Q2M1	I3	R2P1	K1	TP203	L5	TP513	K3
C237	M6	C320	J4	C504	L3	Q2M2	I4	R2P4	I2	TP204	M3	TP514	K3
C271	M5	C335	I2	C505	K6	Q2M3	I2	R2P5	I2	TP205	K5	TP515	L3
C272	I4	C336	J2	C508	L2	Q301	I5	R2P7	I3	TP206	L5	TP516	K3
C273	M5	C337	J2	C509	M1	Q302	I5	R2P8	I3	TP209	L6	TP517	L3
C274	M6	C345	J1	C513	N1	Q303	I8	R2Q1	I3	TP210	L6	TP518	K3
C278	L5	C372	M7	C514	L3	Q371	I5	R316	K3	TP211	L6	TP519	M2
C284	M6	C375	J5	C516	M1	Q372	I5	R317	K3	TP212	L6	TP520	L3
C2A0	K6	C382	J5	C519	K1	Q373	I6	R318	K3	TP213	L6	TP521	M3
C2A1	L8	C383	I5	C530	L8	Q404	H7	R319	K3	TP214	L6	TP522	L3
C2A2	L8	C384	I5	C535	N8	Q419	K6	R320	K3	TP215	L6	TP523	L3
C2A3	K8	C3M1	J4	C536	N8	R201	M4	R321	K3	TP216	L6	TP524	L3
C2B1	L7	C3M2	J4	C537	N8	R202	M4	R322	K4	TP218	M5	TP525	L1
C2B4	L7	C402	J6	C538	M8	R203	M4	R340	I4	TP219	L6	TP526	K2
C2B5	K7	C403	J6	C539	M8	R204	M4	R341	I4	TP220	L6	TP527	K2
C2B6	K7	C404	K5	C540	M8	R218	L5	R353	I5	TP221	L6	TP528	K2
C2B7	K7	C406	K6	IC201	L5	R219	K5	R356	H7	TP223	M6	TP529	K1
C2C0	L8	C407	J7	IC205	N5	R220	K5	R358	I7	TP224	M6	TP530	K1
C2C2	L8	C409	K6	IC2A1	L7	R221	M5	R3M1	J4	TP225	M6	TP531	K1
C2C3	L8	C410	K7	IC301	J3	R279	M6	R3M2	J4	TP226	M6	TP532	K1
C2C8	K8	C413	J7	IC302	J2	R2A0	L7	R406	J6	TP228	M6	TP533	K1
C2C9	K7	C415	K7	IC303	I2	R2A1	L8	R424	H8	TP229	M6	TP534	K2
C2D1	L7	C419	K8	IC304	K5	R2B9	K8	R425	H7	TP230	M6	TP535	K1
C2D2	L7	C421	J8	IC371	M7	R2C1	K8	R426	H7	TP231	M6	TP536	L1
C2D3	K7	C422	H7	IC372	I5	R2C2	K7	R428	H7	TP232	M6	TP537	L1
C2D4	K8	C424	H7	IC401	J6	R2C3	K7	R429	H7	TP233	H4	TP538	L1
C2D5	K8	C429	M7	IC402	J7	R2C6	L7	R502	K6	TP234	H4	TP539	L1
C2D6	K8	C430	M7	IC403	H7	R2D6	L8	R504	L3	TP235	M5	TP540	L1
C2D7	K7	C451	H6	IC404	M7	R2D7	K8	R505	M3	TP241	L6	TP541	L2
C2M1	H3	C452	J6	IC451	I6	R2E6	L8	R512	L1	TP242	M4	TP542	L1
C2M2	H4	C453	I6	IC452	I7	R2E7	K7	R513	L1	TP243	M4	TP543	L2
C2M3	H4	C454	I6	IC453	I7	R2M1	H4	R515	H8	TP244	M5	TP544	L1
C2M4	I4	C455	I7	IC454	J7	R2M2	H4	R516	H8	TP245	M4	TP545	K3
C2M5	I4	C456	I7	IC501	M2	R2M3	H4	R517	H8	TP2A1	L7	TP546	L3
C2M7	K1	C460	I8	IC502	L2	R2M5	H4	R518	H8	TP2A2	L6	TP547	L1
C2N1	I3	C461	I7	L2A1	L6	R2M6	H4	R519	H8	TP2A3	L6	TP548	L1
C2N3	I3	C464	I7	L2A2	K8	R2M7	H4	R520	H8	TP2A4	L7	TP549	L3
C2N4	I3	C466	I8	L301	K4	R2M8	I3	R521	H8	TP2A7	K6	TP550	M1
C301	K4	C467	I7	L302	K4	R2M9	I4	R522	H8	TP2A8	L6	X301	J5
C302	K4	C468	J7	L306	I2	R2N0	I4	R524	H8	TP302	J2	X501	M1
C303	I2	C472	I8	L451	I6	R2N1	I4	R525	H8	TP303	J2	ZD501	M1
C304	I2	C473	J7	L502	L2	R2N2	I4	R526	H8	TP501	K3		
C306	J2	C476	I7	L503	M1	R2N3	I4	R529	H8	TP502	L1		
C307	J2	C479	J8	L505	N1	R2N4	I4	R557	N3	TP507	K3		
C309	J2	C480	J7	L507	K4	R2N5	I3	R558	N3	TP508	K3		



# SECTION 4. MECHANISM

## ■ DECK MECHANISM PARTS LOCKATION

### • Top View(With Tray)

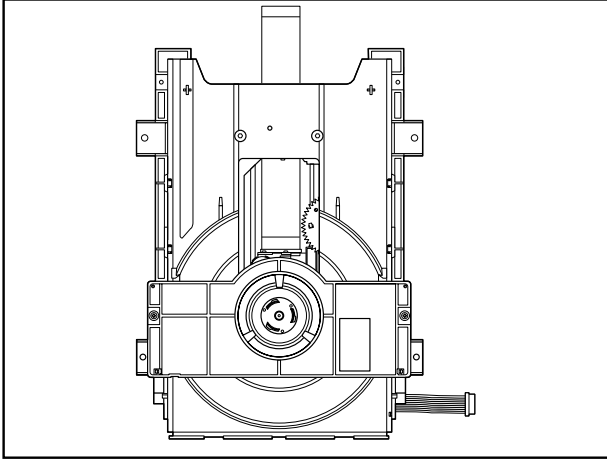

### • Top View(Without Tray)

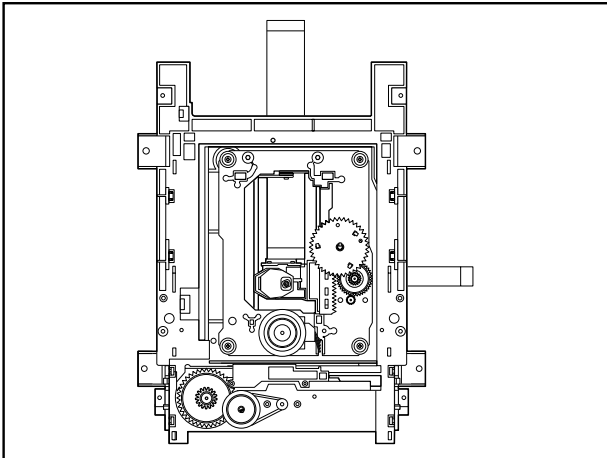

### • Bottom View

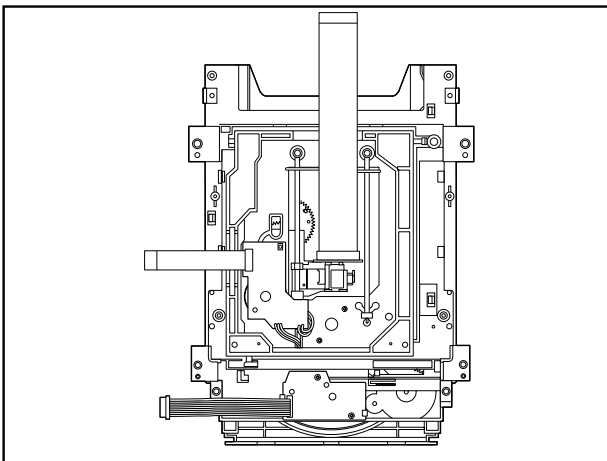

Procedure		Parts	Fixing Type	Disass embly	Figure
Starting No.					
	1	Holder Clamp	2 Screws, 2 Locking Tabs		4-1
1	2	Clamp Assmby Disc	2 Locking Tabs		4-1
1, 2	3	Plate Clamp			4-1
1, 2, 3	4	Magnet Clamp			4-1
1, 2, 3, 4	5	Clamp Upper			4-1
1	6	Tray Disc			4-2
1, 6	7	Bass Assembly Sled			4-3
1, 2, 6	8	Gear Assmby Feed	4 Screws, 1 Connector 1 Locking Tabs		4-3
1, 2, 6, 8	9	Gear Middle			4-3
1, 2, 6, 8, 9	10	Gear Assembly Rack	1 Screw		4-3
1, 2, 7	11	Rubber Rear			4-3
1, 2, 7	12	Frame Assembly	1 Screw	Bottom	4-4
1, 2	13	Belt Loading	1 Locking Tab		4-4
1, 2, 13	14	Gear Pulley			4-4
1, 2, 13, 14	15	Gear Loading	1 Locking Tab		4-4
1, 2, 7, 12, 13, 14	16	Guide Up/Down			4-4
1, 2, 13	17	PWB Assembly Loading	1 Locking Tab 1 Hook 2 Screw	Bottom	4-4
1, 2, 7, 12, 13, 14, 15, 16, 17	18	Bass Main	2 Locking Tabs		4-4

#### Note

When reassembling, perform the procedure in reverse order.

The "Bottom" on Disassembly column of above Table indicates the part should be disassembled at the Bottom side.

# DECK MECHANISM DISASSEMBLY

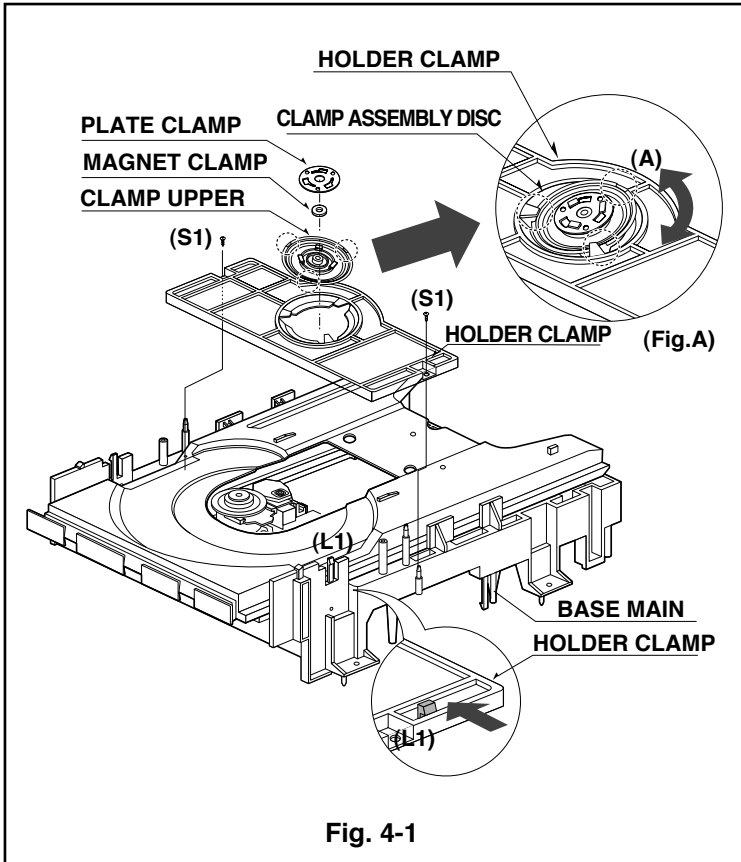

Fig. 4-1

## 1. Holder Clamp (Fig. 4-1)

- 1) Release 2 Screws(S1).
- 2) Unhook 2 Locking Tabs(L1).
- 3) Lift up the Holder Clamp and then separate it from the Base Main.

### 1-1. Clamp Assembly Disc

- 1) Place the Clamp Assembly Disc as Fig. (A)
- 2) Lift up the Clamp Assembly Disc in direction of arrow(A).
- 3) Separate the Clamp Assembly Disc from the Holder Clamp.

### 1-1-1. Plate Clamp

- 1) Turn the Plate Clamp to counterclockwise direction and then lift up the Plate Clamp.

### 1-1-2. Magnet Clamp

### 1-1-3. Clamp Upper

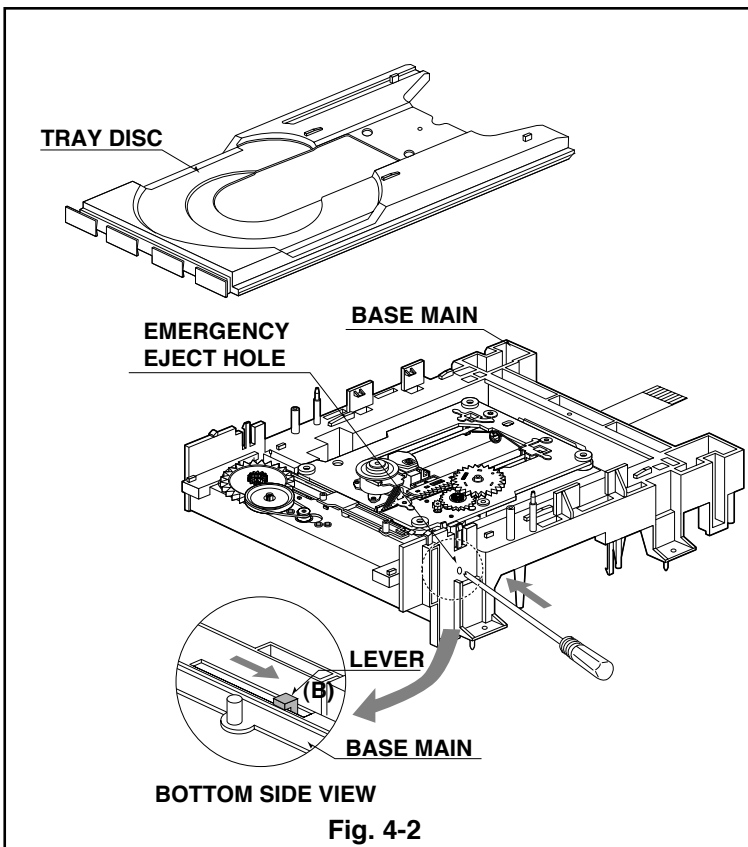

Fig. 4-2

## 2. Tray Disc (Fig. 4-2)

- 1) Insert and push a Driver in the emergency eject hole(A) at the right side, or put the Driver on the Lever(B) of the Gear Emergency and pull the Lever(B) in direction of arrow so that the Tray Disc is ejected about 15~20mm.
- 2) Pull the Tray Disc until it is separated from the Base Main completely.

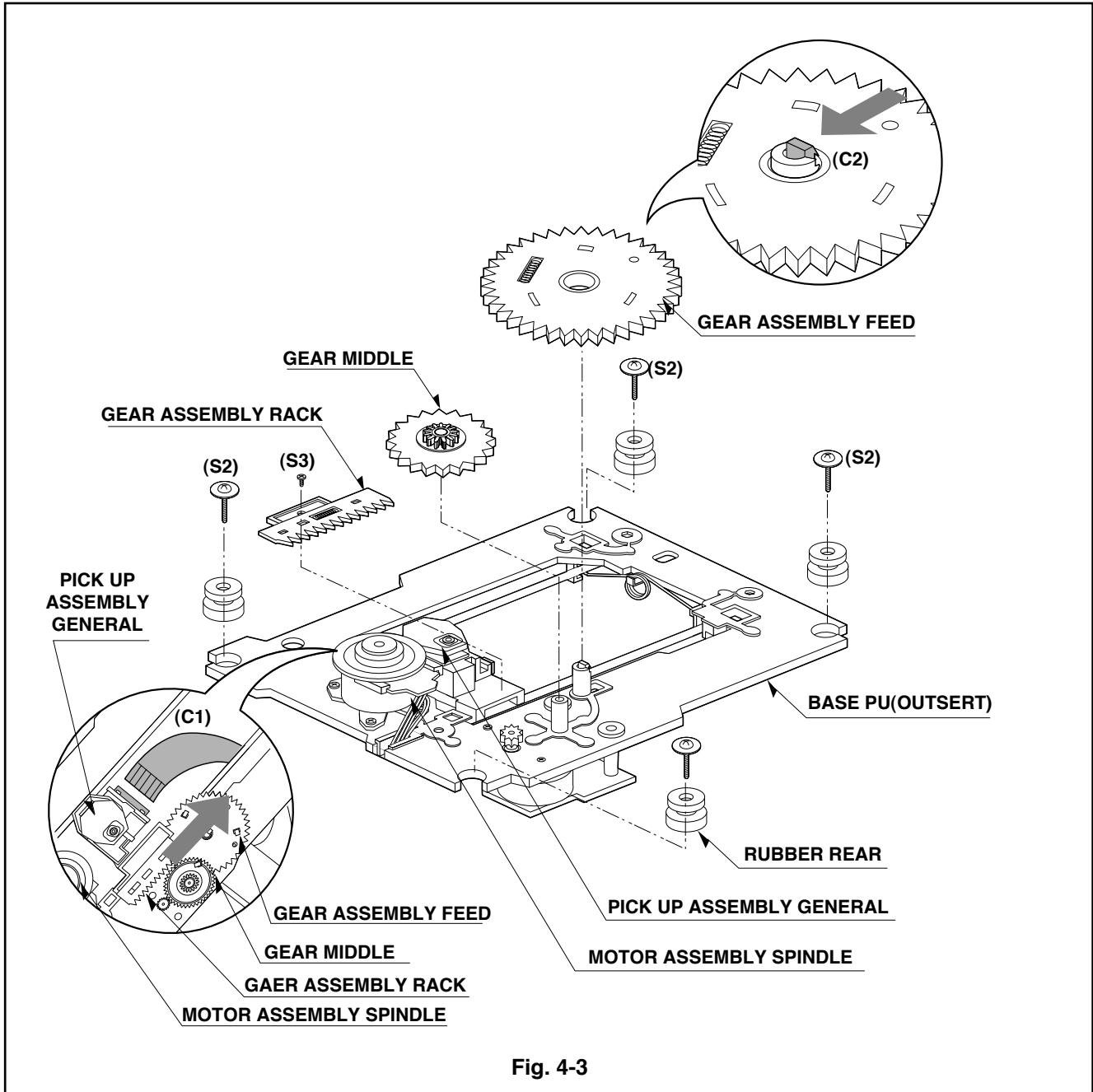

Fig. 4-3

**3. Base Assembly Sled (Fig. 4-3)**

- 1) Release 4 Screw(S2).
- 2) Disconnect the FFC Connector(C1)

**3-1. Gear Assembly Feed**

- 1) Unhook the Locking Tab(L2) in direction of arrow.

**3-2. Gear Middle**

**3-3. Gear Assembly Rack**

- 1) Release the Scerw(S3)

**4. Rubber Rear (Fig. 4-3)**

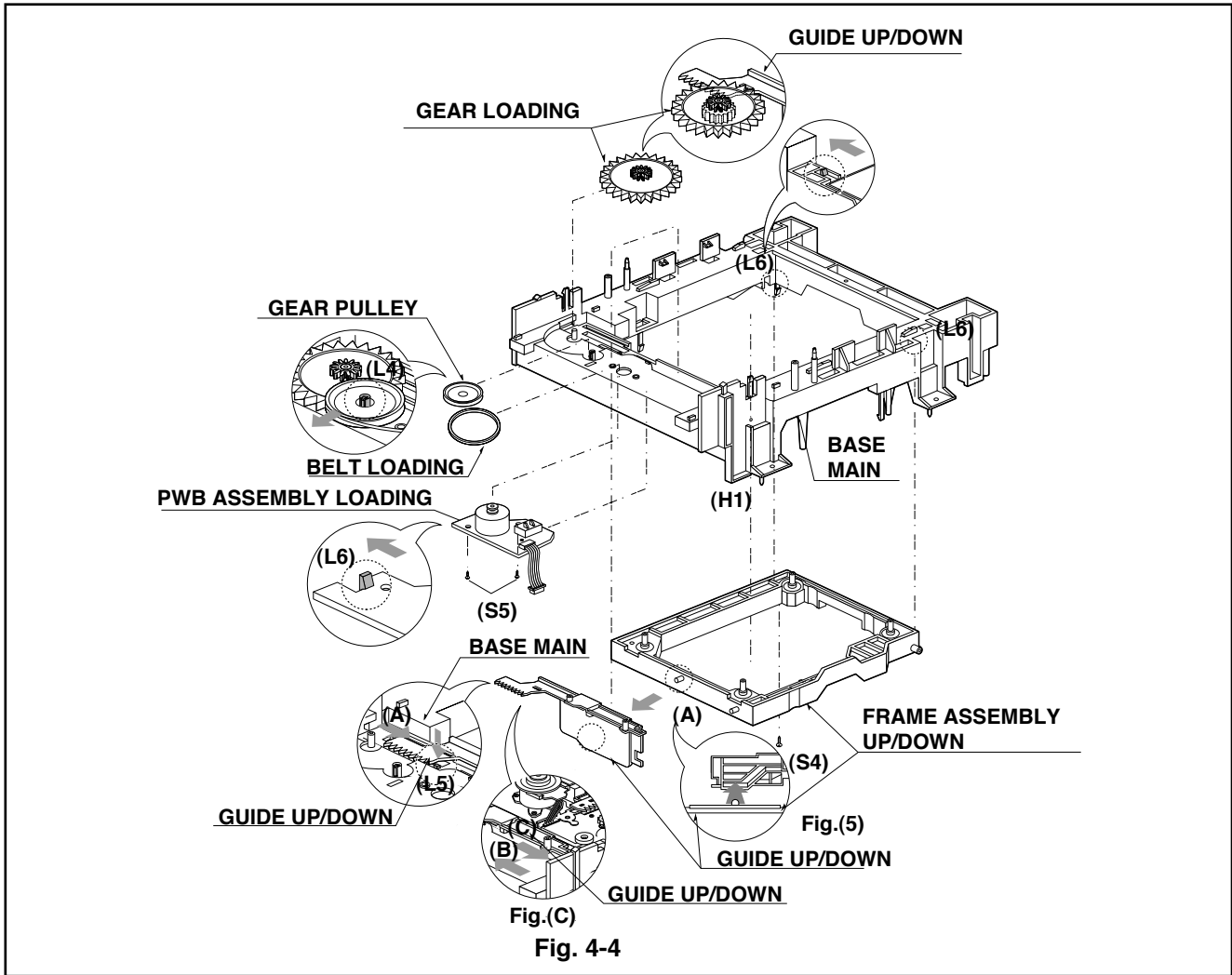

## 5. Frame Assembly Up/Down

### [Note]

Put the Base Main face down(Bottom Side)

- 1) Release the Screw(S4)
- 2) Unlock the Locking Tab(L3) in direction of arrow and then lift up the Frame Assembly Up/Down to separate it from the Base Main.

### [Note]

- When reassembling move the Guide Up/Down in direction of arrow(C) until it is positioned as Fig.(C).
- When reassembling insert (A) portion of the Frame Assembly Up/Down in the (B) portion of the Guide Up/Down as Fig.(B)

## 6. Belt Loading(Fig. 4-4)

### [Note]

Put the Base Assembly Main on original position (Top Side)

## 7. Gear pulley (Fig. 4-4)

- 1) Unlock the Locking Tab(L4) in direction of arrow(B) and then separate the Gear Pulley from the Base Main.

## 8. Gear Loading (Fig. 4-4)

## 9. Guide Up/Down (Fig. 4-4)

- 1) Move the Guide Up/Down in direction of arrow(A) as Fig.(A)
- 2) Push the Locking Tab(L5) down and then lift up the Guide Up/Down to separate it from the Base Main.

### [Note]

When reassembling place the Guide Up/Down as Fig.(C) and move it in direction arrow(B) until it is locked by the Locking Tab(L5). And confirm the Guide Up/Down as Fig.(A)

## 10. PWB Assembly Loading

### [Note]

Put the Base Main face down(Bottom Side)

- 1) Release 2 Screws(S5)
- 2) Unhook the Loading Motor Connector (C2) from the Hook (H1) on the Base Main.
- 3) Unlock 2 Locking Tabs(L6) and separate the PWB Assembly Loading from the Base Main.

## 11. Base Main(Fig. 4-4)

# SECTION 5. EXPLODED VIEWS

## • CABINET AND MAIN FRAME SECTION

NOTE) Refer to "SECTION 7 REPLACEMENT PARTS LIST" in order to look for the part number of each part.

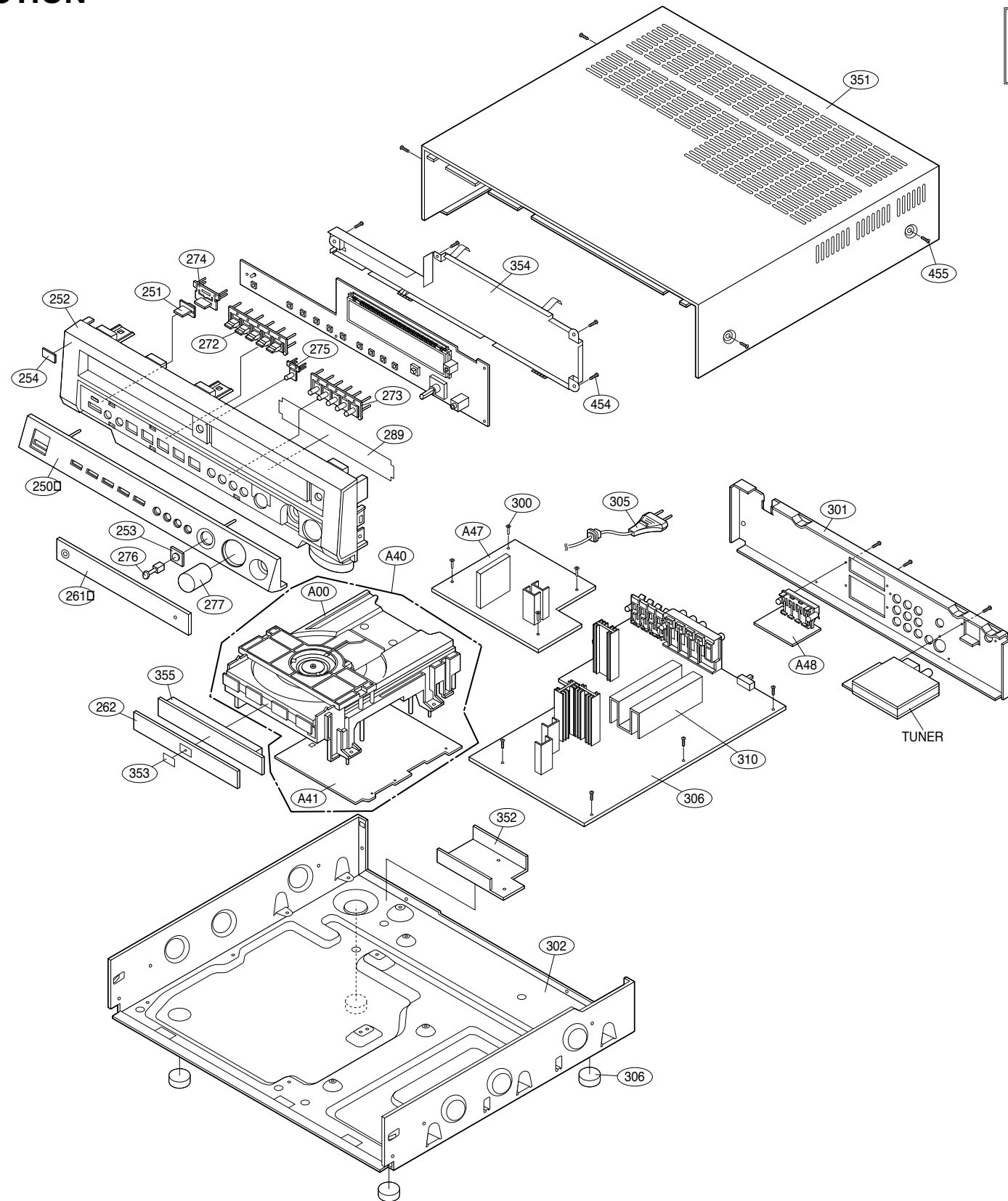

• Deck Mechanism Exploded View

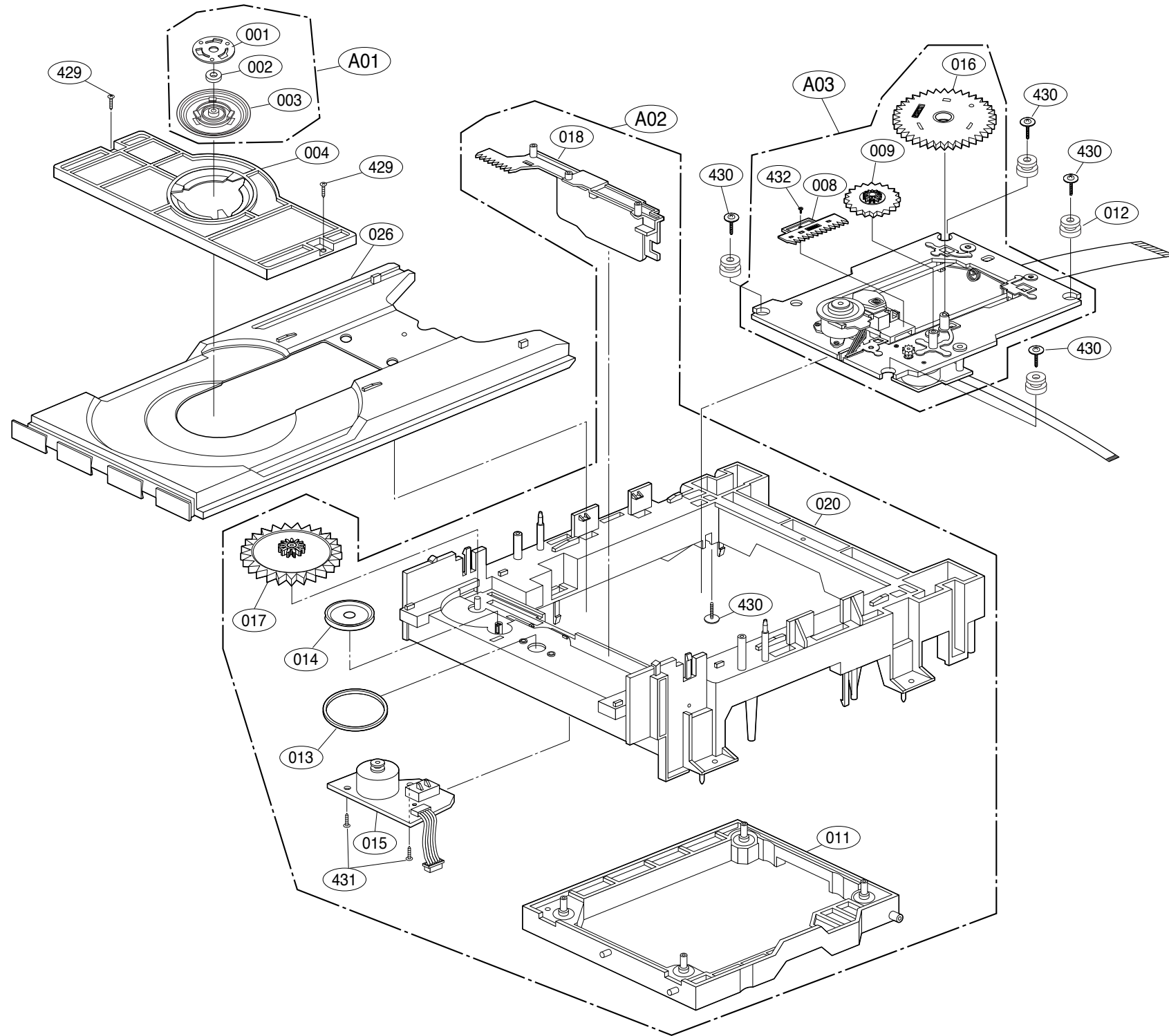

LOCA. NO.	PART NO.	DESCRIPTION	SPECIFICATION
A00	6721RJ0320A	DECK ASSEMBLY,VIDEO	DP-2RM(MULTI)-CKD-HZ
A01	4861R-0006A	CLAMP ASSY	DISC(DP2)
A02	3041R-0040A	BASE ASSEMBLY	MAIN(DP2,MULTI)-HZ
A03	3041R-0041A	BASE ASSEMBLY	SLED(DP2,MULTI)-HZ
001	3300R-0547A	PLATE	CLAMP
002	5016H-1016B	MAGNET	CLAMP(LDM-R608,10*5,1*1.5T)
003	4860R-0006A	CLAMP	UPPER
004	4930R-0171A	HOLDER	CLAMP
008	4470R-0047A	GEAR	ASSY RACK
009	4470R-0053A	GEAR	MIDDLE
012	5040R-0047A	RUBBER	REAR(E2,5040H-1054A),YAMAUCHI
013	4400R-0006A	BELT	LOADING
014	4470R-0055A	GEAR	PULLEY
015	6871R-4508A	PWB(PCB) ASSEMBLY,TOTAL	LD,DP-2 MULTIHZ
016	4470R-0050A	GEAR	ASSY FEED
017	4470R-0056A	GEAR	LOADING
018	4974R-0023A	GUIDE	UP/DOWN
020	3040R-0048A	BASE	MAIN(MULTI)
026	3390R-0005A	TRAY	DISC
429	1SZZR-0012A	SCREW,	B-TITE
430	1SZZH-1003A	SCREW,	+ D2.0 6MM SWRCH16ANIY 4.5MM
431	1SZZH-1007B	SCREW,	+ D2.0 6MM SWRCH16AZNBK 4MM 1
432	1SZZR-0011A	SCREW,	MACHINE

# SECTION 6. SPEAKER PART

MODEL: FE-3500TE

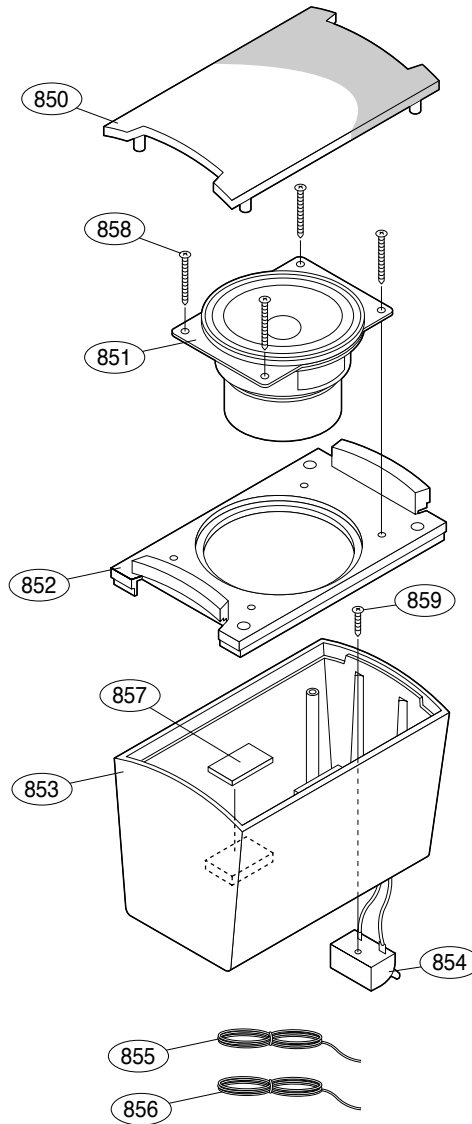

(LG BRAND) MODEL : FE - 3500TE

NSP : Non SVC Parts

RUN DATE : 07.JUNE.2002

LOCA. NO.	PART NO.	DESCRIPTION	SPECIFICATION	REMARKS
850	3701RM0003A	NET ASSY	ASSY,FE-3500TE(SATELLITE)	NSP
851	6400RMSC02A	SPEAKER,GENERAL	MSF-30SB30L(P.M.S) SAMMI 4OHM	
852	3720RMF009A	PANEL,FRONT	FRONT FE-3500TE/DV25TE	NSP
853	3110RM0005A	CASE	REAR FE-3500TE/DV25TE (SATELLITE)	NSP
854	6871RU4116A	PWB(PCB) ASSY,SUBSET(AUDIO)	FE-3500SE(STANDARD) 2P TERMINA	NSP
855	6871RU4117A	PWB(PCB) ASSY,SUBSET(AUDIO)	FE-3500TE (STANDARD) 2P WIRE 5	NSP
856	6871RU4117B	PWB(PCB) ASSY,SUBSET(AUDIO)	FE-3500SE(STANDARD) 2P WIRE 10	NSP
857	3806RM0006A	DECO	FE-3500TE PLATE	NSP
858	353M025U	SCREW,DRAWING	+ 2 D3.0 L27.0 MSWR3/FZB	
859	353M050H	SCREW,DRAWING	+ 1 D4.0 L12.0 MSWR3/FZY FE-35	

# SECTION 6. SPEAKER PART

MODEL: FE-3500WE

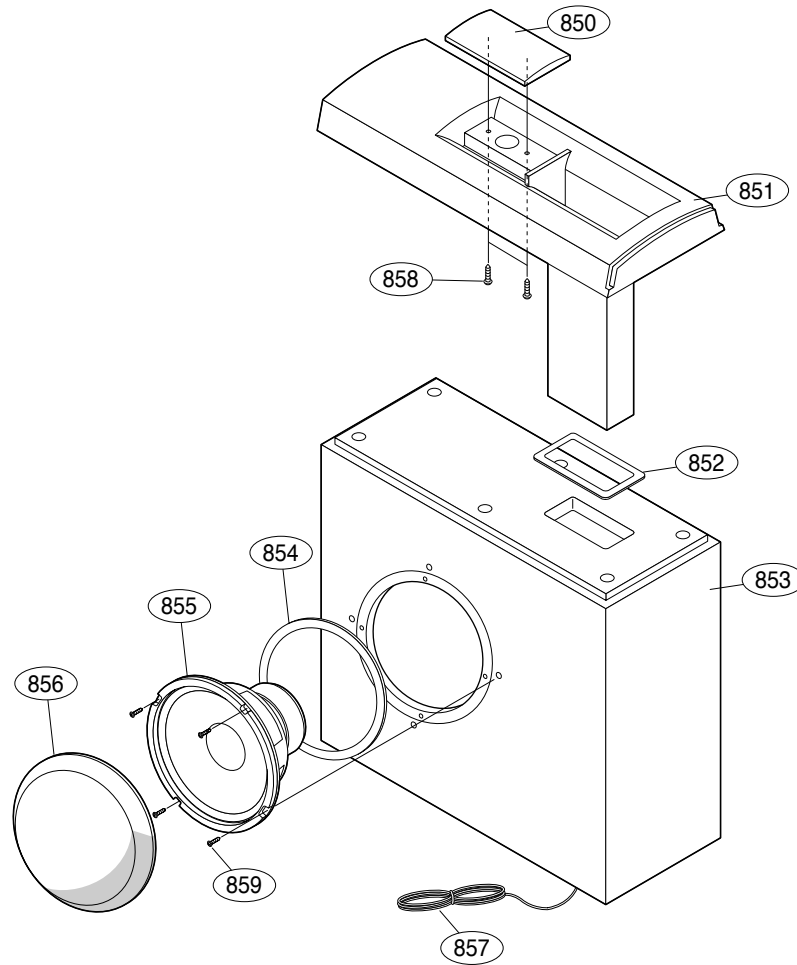

( LG BRAND ) MODEL : FE - 3500WE

RUN DATE : 07.JUNE.2002

NSP : Non SVC Parts

LOCA. NO.	PART NO.	DESCRIPTION	SPECIFICATION	REMARKS
850	3806RM0005A	DECO	RING (DV-3500 SUB WF)	NSP
851	3720RMF010A	PANEL,FRONT	FRONT SUB WF	NSP
852	4766RM0006A	FELT	DUCT,300X10X1T BLACK	NSP
853	3091RMW010A	CABINET ASSY	ASSY,FE-3500WE ALL PB 12T	NSP
854	4766RM0005A	FELT	WF,FE-3500SW,470X7X1T BLACK	NSP
855	6400RMSJ02A	SPEAKER,WOOFER	CW-165B30L 8OHM 30/50W 8	
856	3701RM0005A	NET ASSY	ASSY,FE-3500WE(SUBWOOFER)	NSP
857	6871RU3091A	PWB ASSY,SUBSET(AUDIO)	SPKR CORD ASSY	NSP
858	353M025C	SCREW	TAPTITE, 3X10 FBK	
859	353M050C	SCREW	BH 3.5X16 FBK	