



SERVICE MANUAL

MODEL: DP351G

PORTABLE DVD SERVICE MANUAL

MODEL: DP351G

CAUTION

BEFORE SERVICING THE UNIT, READ THE "SAFETY PRECAUTIONS" IN THIS MANUAL.



 **LG Electronics México S.A. de C.V.**

Av. Sor Juana Inés de la Cruz No 555
Col. San Lorenzo
Tlalnepantla, Estado de México CP 54033
Tel. 321 19 00 Fax. 5 657549
Lada sin costo 01 800 50 481 00

P/NO : AFN56903641

APRIL, 2008

LG

CONTENTS

SECTION 1.....SUMMARY

SECTION 2.....EXPLODED VIEWS

SECTION 3.....ELECTRICAL

SECTION 4.....REPLACEMENT PARTS LIST

SECTION 1

SUMMARY

CONTENTS

PRODUCT SAFETY SERVICING GUIDELINES FOR VIDEO PRODUCTS	1-3
SERVICING PRECAUTIONS.....	1-4
• GENERAL SERVICING PRECAUTIONS	
• INSULATION CHECKING PRODEDURE	
• ELECTROSTATICALLY SENSITIVE (ES) DEVICES	
SPECIFICATIONS	1-5

PRODUCT SAFETY SERVICING GUIDELINES FOR VIDEO PRODUCTS

IMPORTANT SAFETY NOTICE

This manual was prepared for use only by properly trained audio-video service technicians.

When servicing this product, under no circumstances should the original design be modified or altered without permission from LG Corporation. All components should be replaced only with types identical to those in the original circuit and their physical location, wiring and lead dress must conform to original layout upon completion of repairs.

Special components are also used to prevent x-radiation, shock and fire hazard.

These components are indicated by the letter "X" included in their component designators and are required to maintain safe performance. No deviations are allowed without prior approval by LG Corporation.

Circuit diagrams may occasionally differ from the actual circuit used. This way, implementation of the latest safety and performance improvement changes into the set are not delayed until the new service literature is printed.

CAUTION: Do not attempt to modify this product in any way. Never perform customized installations without manufacturer's approval. Unauthorized modifications will not only void the warranty, but may lead to property damage or user injury.

Service work should be performed only after you are thoroughly familiar with these safety checks and servicing guidelines.

GRAPHIC SYMBOLS



The exclamation point within an equilateral triangle is intended to alert the service personnel to important safety information in the service literature.



The lightning flash with arrowhead symbol within an equilateral triangle is intended to alert the service personnel to the presence of noninsulated "dangerous voltage" that may be of sufficient magnitude to constitute a risk of electric shock.



The pictorial representation of a fuse and its rating within an equilateral triangle is intended to convey to the service personnel the following fuse replacement caution notice:

CAUTION: FOR CONTINUED PROTECTION AGAINST RISK OF FIRE, REPLACE ALL FUSES WITH THE SAME TYPE AND RATING AS MARKED NEAR EACH FUSE.

SERVICE INFORMATION

While servicing, use an isolation transformer for protection from AC line shock. After the original service problem has been corrected, make a check of the following:

FIRE AND SHOCK HAZARD

1. Be sure that all components are positioned to avoid a possibility of adjacent component shorts. This is especially important on items transported to and from the repair shop.
2. Verify that all protective devices such as insulators, barriers, covers, shields, strain reliefs, power supply cords, and other hardware have been reinstalled per the original design. Be sure that the safety purpose of the polarized line plug has not been defeated.
3. Soldering must be inspected to discover possible cold solder joints, solder splashes, or sharp solder points. Be certain to remove all loose foreign particles.
4. Check for physical evidence of damage or deterioration to parts and components, for frayed leads or damaged insulation (including the AC cord), and replace if necessary.
5. No lead or component should touch a high current device or a resistor rated at 1 watt or more. Lead tension around protruding metal surfaces must be avoided.
6. After reassembly of the set, always perform an AC leakage test on all exposed metallic parts of the cabinet (the channel selector knobs, antenna terminals, handle and screws) to be sure that set is safe to operate without danger of electrical shock. **DO NOT USE A LINE ISOLATION TRANSFORMER DURING THIS TEST.** Use an AC voltmeter having 5000 ohms per volt or more sensitivity in the following manner: Connect a 1500 ohm, 10 watt resistor, paralleled by a .15 mfd 150V AC type capacitor between a known good earth ground water pipe, conduit, etc.) and the exposed metallic parts, one at a time. Measure the AC voltage across the combination of 1500 ohm resistor and .15 mfd capacitor. Reverse the AC plug by using a non-polarized adaptor and repeat AC voltage measurements for each exposed metallic part. Voltage measured must not exceed 0.75 volts RMS. This corresponds to 0.5 milliamp AC. Any value exceeding this limit constitutes a potential shock hazard and must be corrected immediately.

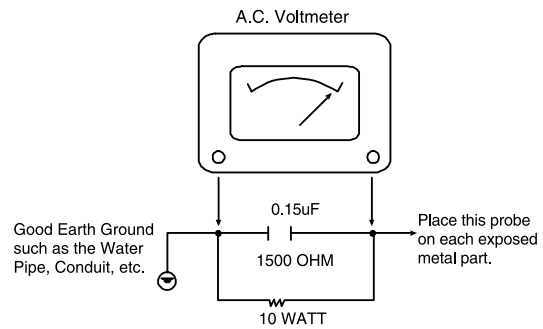

TIPS ON PROPER INSTALLATION

1. Never install any receiver in a closed-in recess, cubbyhole, or closely fitting shelf space over, or close to, a heat duct, or in the path of heated air flow.
2. Avoid conditions of high humidity such as: outdoor patio installations where dew is a factor, near steam radiators where steam leakage is a factor, etc.
3. Avoid placement where draperies may obstruct venting. The customer should also avoid the use of decorative scarves or other coverings that might obstruct ventilation.
4. Wall- and shelf-mounted installations using a commercial mounting kit must follow the factory-approved mounting instructions. A product mounted to a shelf or platform must retain its original feet (or the equivalent thickness in spacers) to provide adequate air flow across the bottom. Bolts or screws used for fasteners must not touch any parts or wiring. Perform leakage tests on customized installations.
5. Caution customers against mounting a product on a sloping shelf or in a tilted position, unless the receiver is properly secured.
6. A product on a roll-about cart should be stable in its mounting to the cart. Caution the customer on the hazards of trying to roll a cart with small casters across thresholds or deep pile carpets.
7. Caution customers against using extension cords. Explain that a forest of extensions, sprouting from a single outlet, can lead to disastrous consequences to home and family.

SERVICING PRECAUTIONS

CAUTION: Before servicing the PORTABLE DVD covered by this service data and its supplements and addends, read and follow the SAFETY PRECAUTIONS. **NOTE:** if unforeseen circumstances create conflict between the following servicing precautions and any of the safety precautions in this publication, always follow the safety precautions.

Remember Safety First :

General Servicing Precautions

1. Always unplug the PORTABLE DVD AC power cord from the AC power source before:

- (1) Removing or reinstalling any component, circuit board, module, or any other assembly.
- (2) Disconnecting or reconnecting any internal electrical plug or other electrical connection.
- (3) Connecting a test substitute in parallel with an electrolytic capacitor.

Caution: A wrong part substitution or incorrect polarity installation of electrolytic capacitors may result in an explosion hazard.

2. Do not spray chemicals on or near this PORTABLE DVD or any of its assemblies.

3. Unless specified otherwise in this service data, clean electrical contacts by applying an appropriate contact cleaning solution to the contacts with a pipe cleaner, cotton-tipped swab, or comparable soft applicator.

Unless specified otherwise in this service data, lubrication of contacts is not required.

4. Do not defeat any plug/socket B+ voltage interlocks with which instruments covered by this service manual might be equipped.

5. Do not apply AC power to this PORTABLE DVD and / or any of its electrical assemblies unless all solid state device heat sinks are correctly installed.

6. Always connect the test instrument ground lead to an appropriate ground before connecting the test instrument positive lead. Always remove the test instrument ground lead last.

Insulation Checking Procedure

Disconnect the attachment plug from the AC outlet and turn the power on. Connect an insulation resistance meter (500V) to the blades of the attachment plug. The insulation resistance between each blade of the attachment plug and accessible conductive parts (Note 1) should be more than 1Mohm.

Note 1: Accessible Conductive Parts include Metal panels, Input terminals, Earphone jacks, etc.

Electrostatically Sensitive (ES) Devices

Some semiconductor (solid state) devices can be damaged easily by static electricity. Such components commonly are called Electrostatically Sensitive (ES) Devices. Examples of typical ES devices are integrated circuits and some field effect transistors and semiconductor chip components.

The following techniques should be used to help reduce the incidence of component damage caused by static electricity.

1. Immediately before handling any semiconductor component or semiconductor-equipped assembly, drain off any electrostatic charge on your body by touching a known earth ground. Alternatively, obtain and wear a commercially available discharging wrist strap device, which should be removed for potential shock reasons prior to applying power to the unit under test.

2. After removing an electrical assembly equipped with ES devices, place the assembly on a conductive surface such as aluminum foil, to prevent electrostatic charge buildup or exposure of the assembly.

3. Use only a grounded-tip soldering iron to solder or unsolder ES devices.

4. Use only an anti-static solder removal device. Some solder removal devices not classified as "anti-static" can generate electrical charges sufficient to damage ES devices.

5. Do not use freon-propelled chemicals. These can generate an electrical charge sufficient to damage ES devices.

6. Do not remove a replacement ES device from its protective package until immediately before you are ready to install it. (Most replacement ES devices are packaged with leads electrically shorted together by conductive foam, aluminum foil, or comparable conductive material).

7. Immediately before removing the protective material from the leads of a replacement ES device, touch the protective material to the chassis or circuit assembly into which the device will be installed.

Caution: Be sure no power is applied to the chassis or circuit, and observe all other safety precautions.

8. Minimize bodily motions when handling unpackaged replacement ES devices. (Normally harmless motion such as the brushing together of your clothes fabric or the lifting of your foot from a carpeted floor can generate static electricity sufficient to damage an ES device.)

SPECIFICATIONS

• GENERAL

Power requirements	DC 12V
Power consumption	12W
External Dimensions	202 x 39 x 164mm (W x H x D)
Net Weight (Approx.)	0.85kg
Operating temperature:	5°C to 40°C
Operating humidity	5% to 90%
Laser	Semiconductor laser
Signal system	NTSC

• CONNECTORS

Audio/Video Output	ø3.5mm mini jack x 1
- Video: 1.0V(p-p), 75Ω, sync negative	
- Audio: 1.5Vrms (1kHz, 0dB)	
Earphone terminal	ø3.5mm stereo mini jack x 1

• LIQUID CRYSTAL DISPLAY

Panel size	7 inches wide (diagonal)
Projection system	R.G.B. stripe
Driving system	TFT active matrix
Resolution	480 x 234 (WQVGA)

• SUPPLIED ACCESSORIES

- RCA Video/Audio cable
- AC Adapter (MPA-630)
- Automotive Adapter (DPDC1)
- Remote Control
- Battery for Remote Control (Lithium Battery)

SECTION 2

EXPLODED VIEWS

CONTENTS

EXPLODED VIEWS	2-2
1. CABINET AND MAIN FRAME SECTION	2-2
2. PACKING ACCESSORY SECTION.....	2-3

EXPLODED VIEWS

1. CABINET AND MAIN FRAME SECTION

NOTES) THE EXCLAMATION POINT WITHIN AN EQUILATERAL TRIANGLE IS INTENDED TO ALERT THE SERVICE PERSONNEL TO THE PRESENCE OF IMPORTANT SAFETY INFORMATION IN SERVICE LITERATURE.

5

4

3

2

1

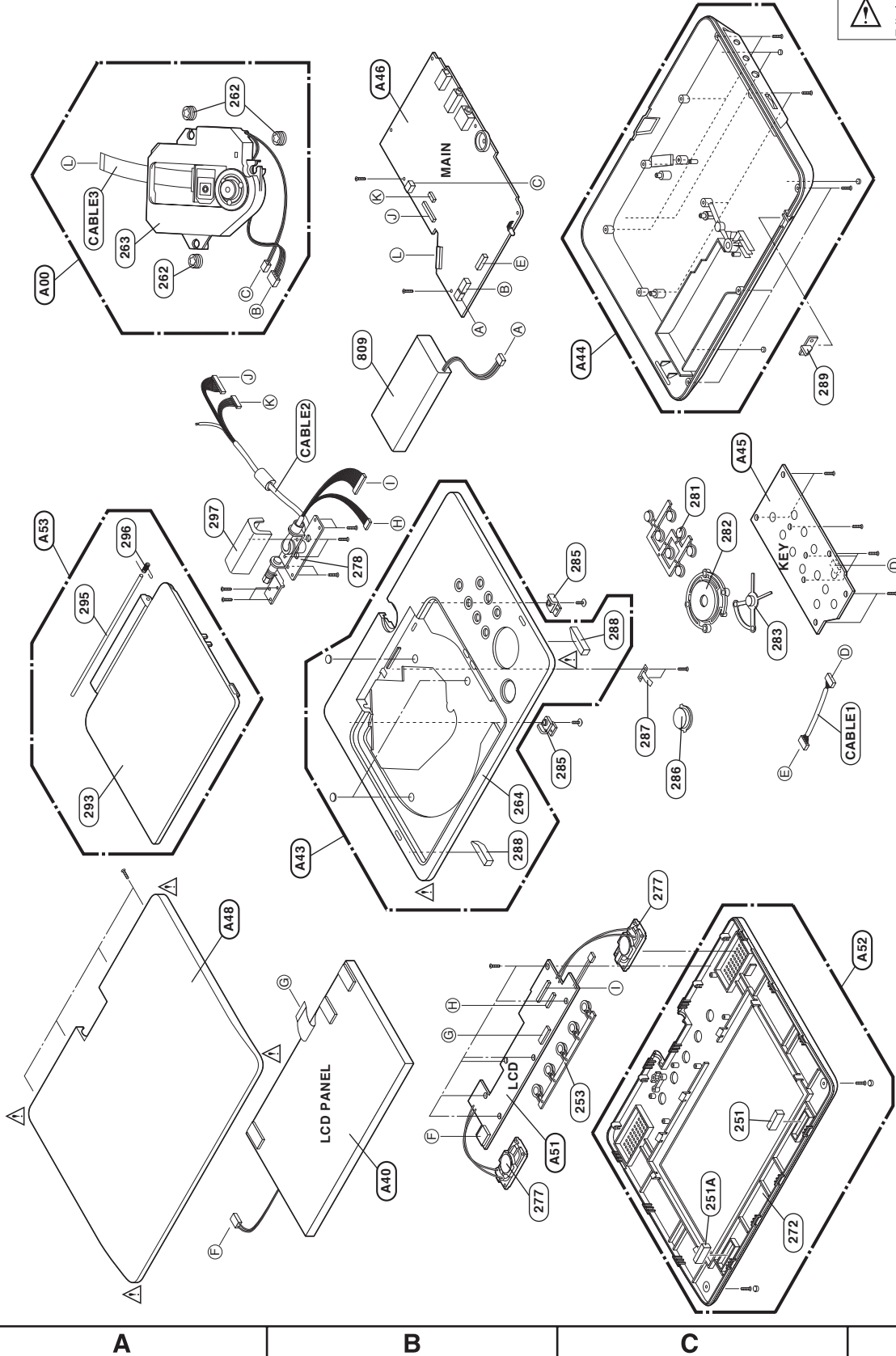

2. PACKING ACCESSORY SECTION

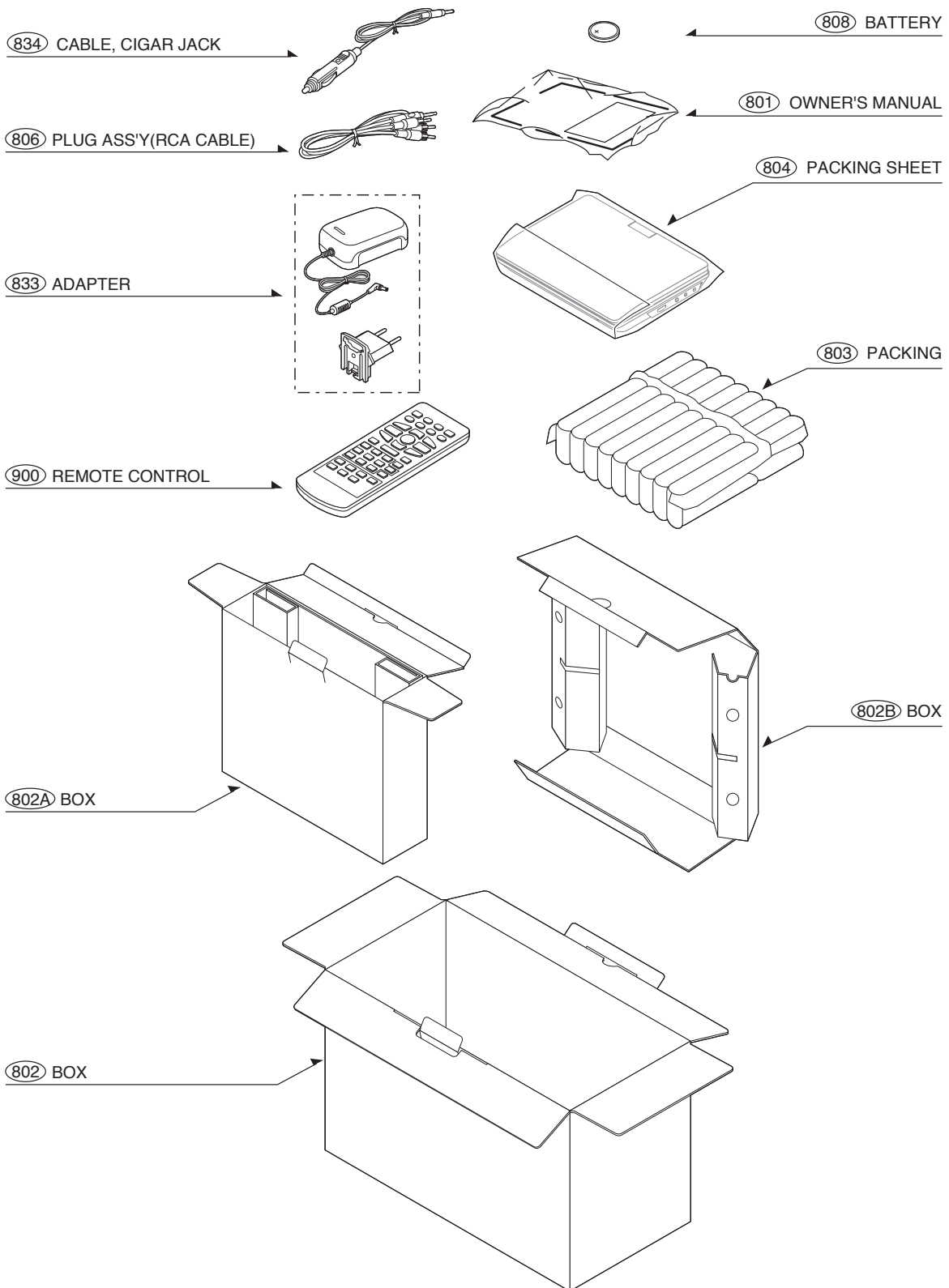

MEMO

A series of horizontal dotted lines for writing a memo.

SECTION 3

ELECTRICAL

CONTENTS

LCD PART	3-2
LCD ELECTRICAL TROUBLESHOOTING GUIDE	3-2
BLOCK DIAGRAM	3-3
CIRCUIT DIAGRAM	3-5
PRINTED CIRCUIT BOARD DIAGRAM	3-7
MAIN PART	3-11
MAIN ELECTRICAL TROUBLESHOOTING GUIDE	3-11
1. DC-DC CONVERTER CIRCUIT	3-11
2. MPEG CIRCUIT	3-14
3. RF/SERVO CIRCUIT	3-15
4. CHARGING CIRCUIT	3-18
DETAILS AND WAVEFORMS ON SYSTEM TEST AND DEBUGGING	3-19
1. SYSTEM 27MHz CLOCK, RESET & FLASH R/W SIGNAL	3-19
2. SDRAM CLOCK	3-19
3. DISC TYPE JUDGEMENT WAVEFORM	3-20
4. FOCUS ON WAVEFORM.....	3-22
5. SPINDLE CONTROL WAVEFORM (NO DISC CONDITION).....	3-22
6. TRACKING CONTROL RELATED SIGNAL (SYSTEM CHECKING)	3-23
7. MT1389 AUDIO OPTICAL AND COAXIAL OUTPUT (ASPDIF)	3-24
8. MT1389 VIDEO OUTPUT WAVEFORM	3-24
9. AUDIO OUTPUT FROM AUDIO DAC	3-25
WIRING CONNECTION DIAGRAMS	3-26
1. WIRING CONNECTION DIAGRAMS-1	3-26
2. WIRING CONNECTION DIAGRAMS-2	3-27
BLOCK DIAGRAMS	3-29
1. OVERALL BLOCK DIAGRAM	3-29
2. POWER BLOCK DIAGRAM.....	3-31
3. SERVO BLOCK DIAGRAM.....	3-33
4. SYSTEM BLOCK DIAGRAM.....	3-35
5. AV BLOCK DIAGRAM	3-37
CIRCUIT DIAGRAMS	3-39
1. MPEG CIRCUIT DIAGRAM	3-39
2. MEMORY CIRCUIT DIAGRAM	3-41
3. OPU & MOTOR CIRCUIT DIAGRAM	3-43
4. AV CIRCUIT DIAGRAM.....	3-45
5. CHARGE CIRCUIT DIAGRAM.....	3-47
6. LCD I/F CIRCUIT DIAGRAM.....	3-49
7. KEY MENU CIRCUIT DIAGRAM	3-51
• CIRCUIT VOLTAGE CHART	3-53
PRINTED CIRCUIT BOARD DIAGRAMS	3-57
1. MAIN P.C.BOARD	3-57
2. KEY MENU P.C.BOARD	3-61

LCD PART

LCD ELECTRICAL TROUBLESHOOTING GUIDE

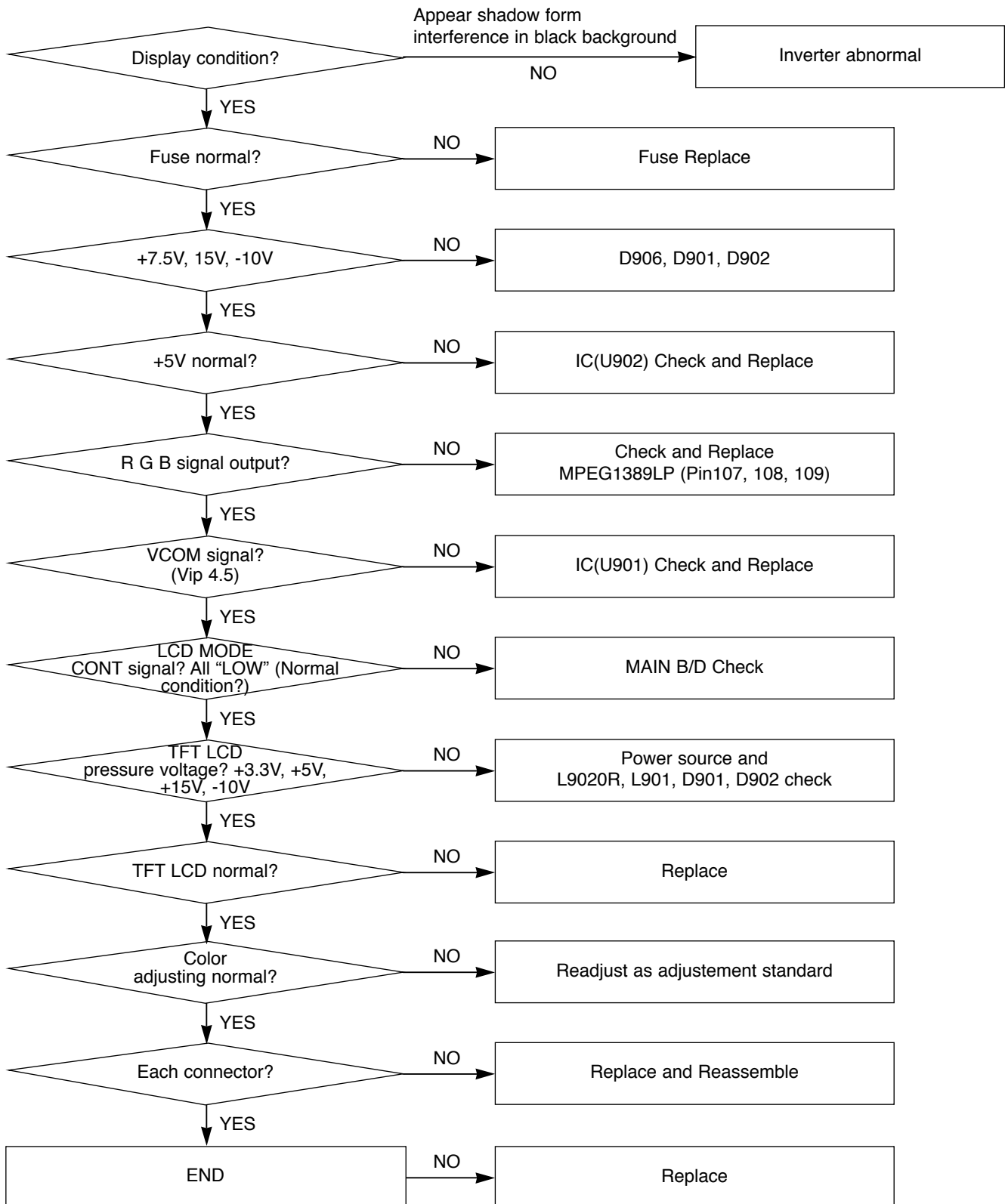

BLOCK DIAGRAM

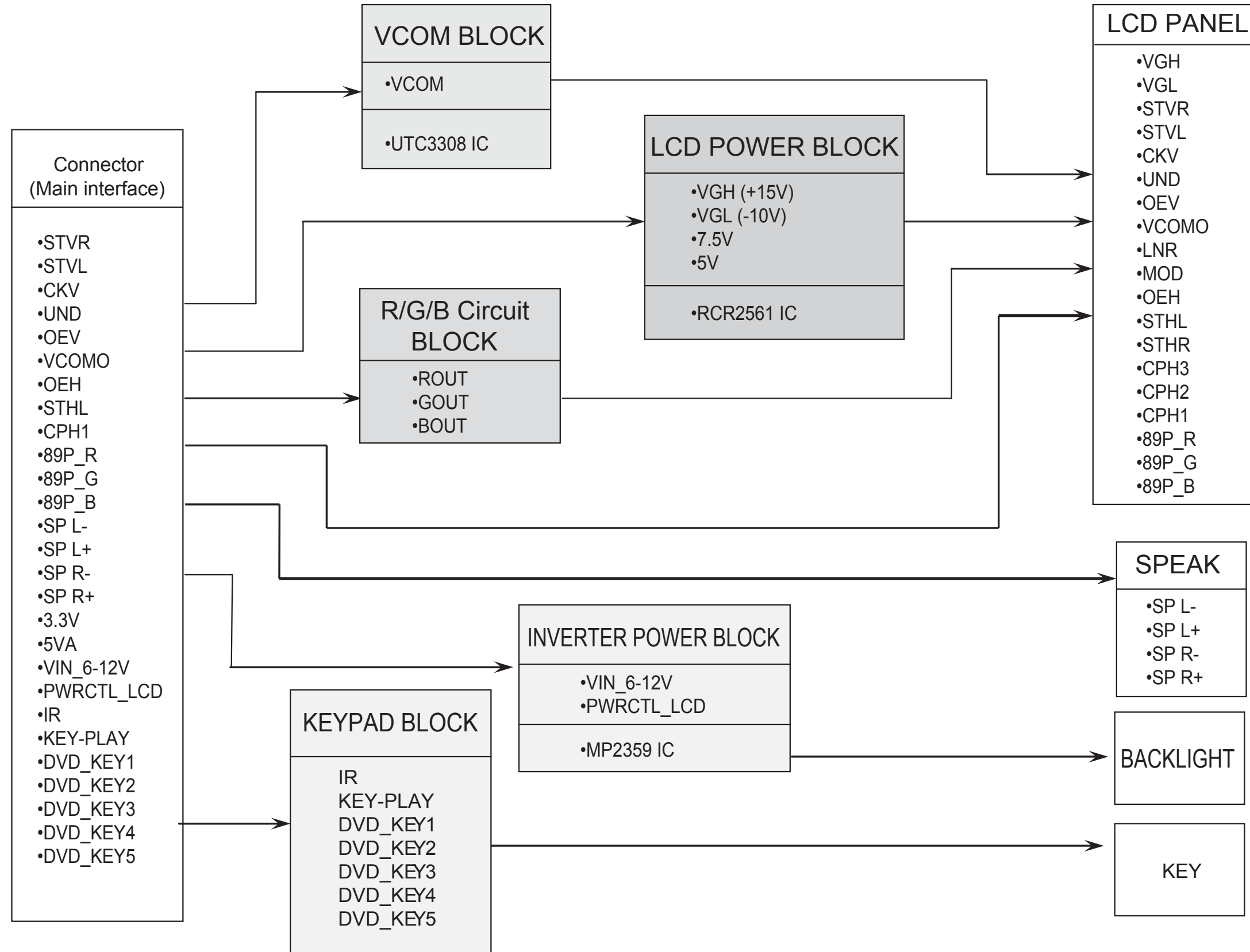

CIRCUIT DIAGRAM

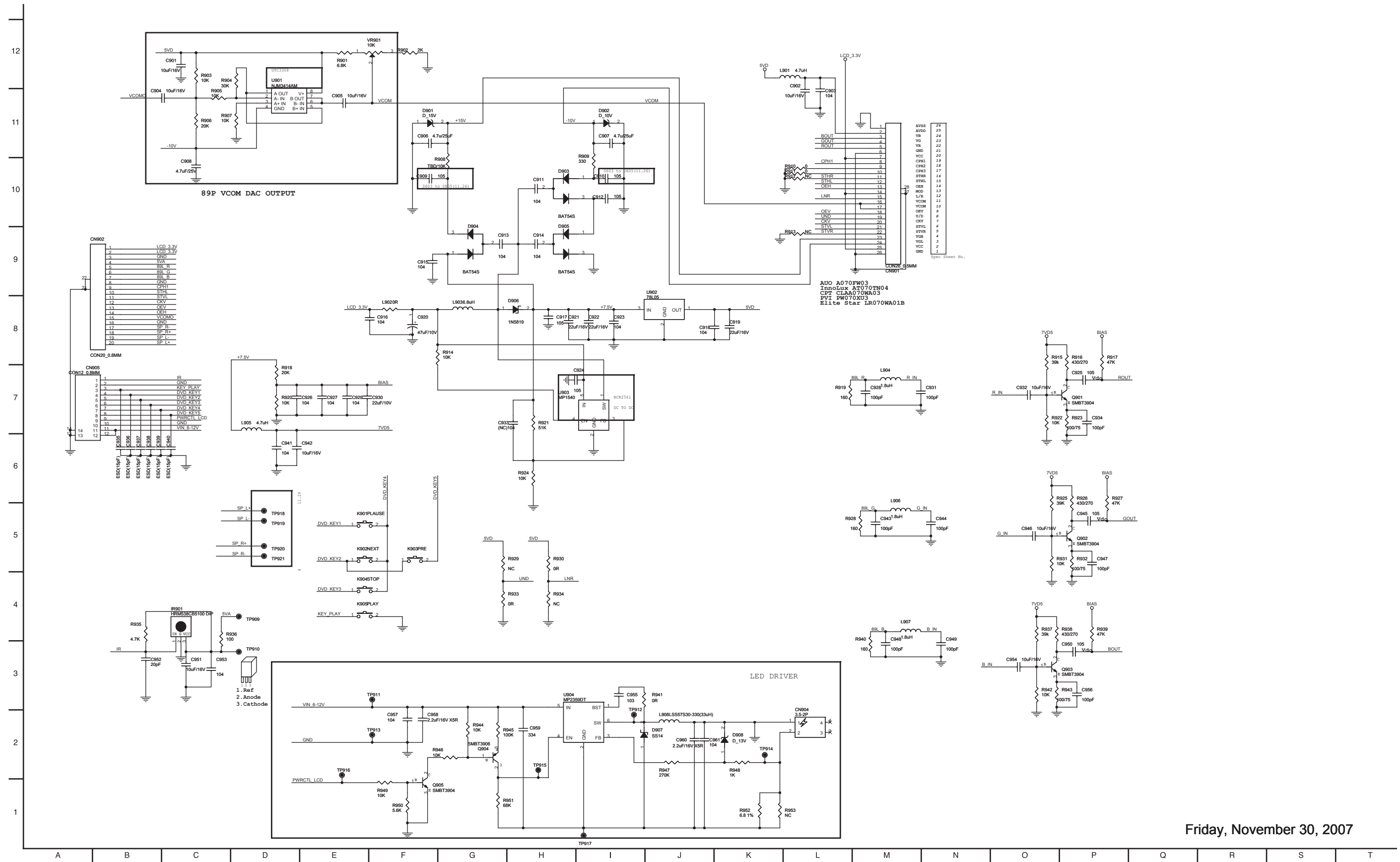

Friday, November 30, 2007

PRINTED CIRCUIT BOARD DIAGRAM

(TOP VIEW)

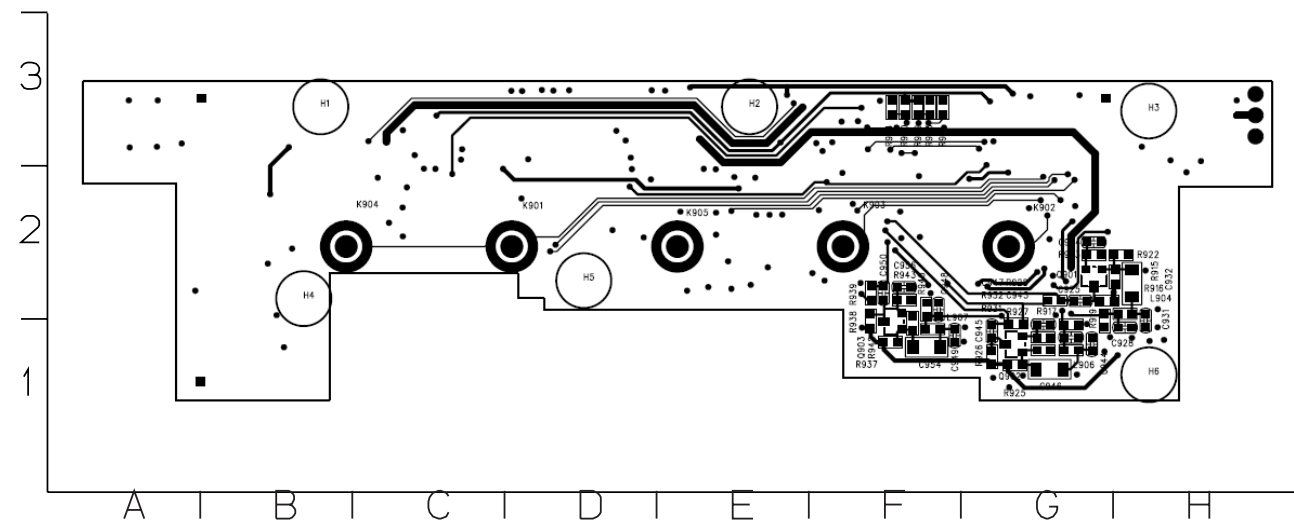

(BOTTOM VIEW)

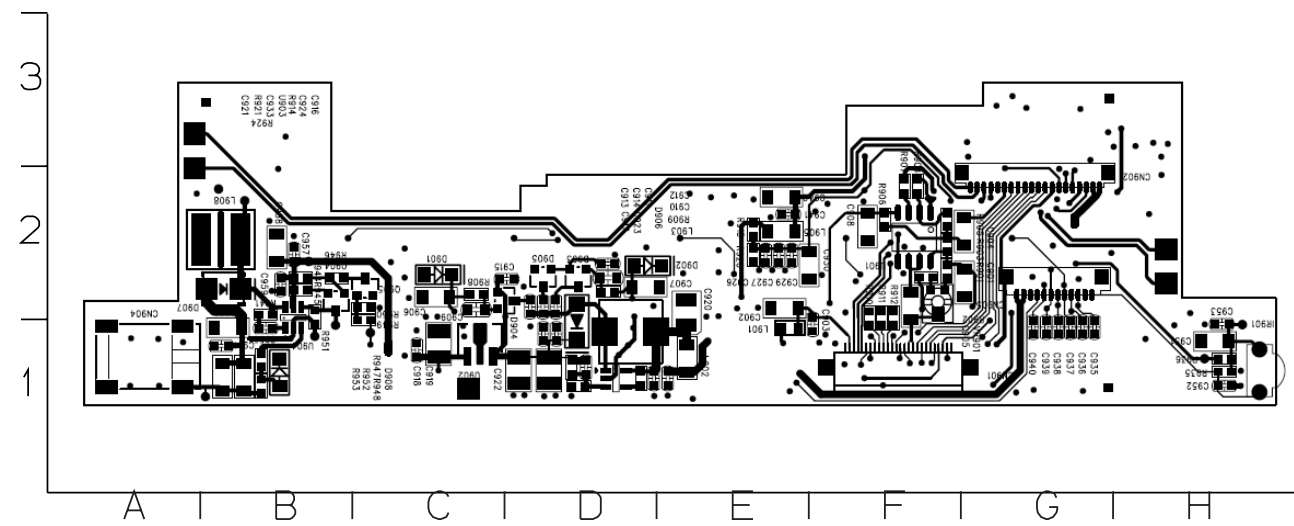

MEMO

A series of horizontal dotted lines for taking notes, spanning the width of the page.

MEMO

Ruled area for writing on page 3-9.

MEMO

Ruled area for writing on page 3-10.

MAIN PART

MAIN ELECTRICAL TROUBLESHOOTING GUIDE

1. DC-DC CONVERTER CIRCUIT

A. NO POWER ON BY ADAPTOR

B. NO POWER ON BY BATTERY

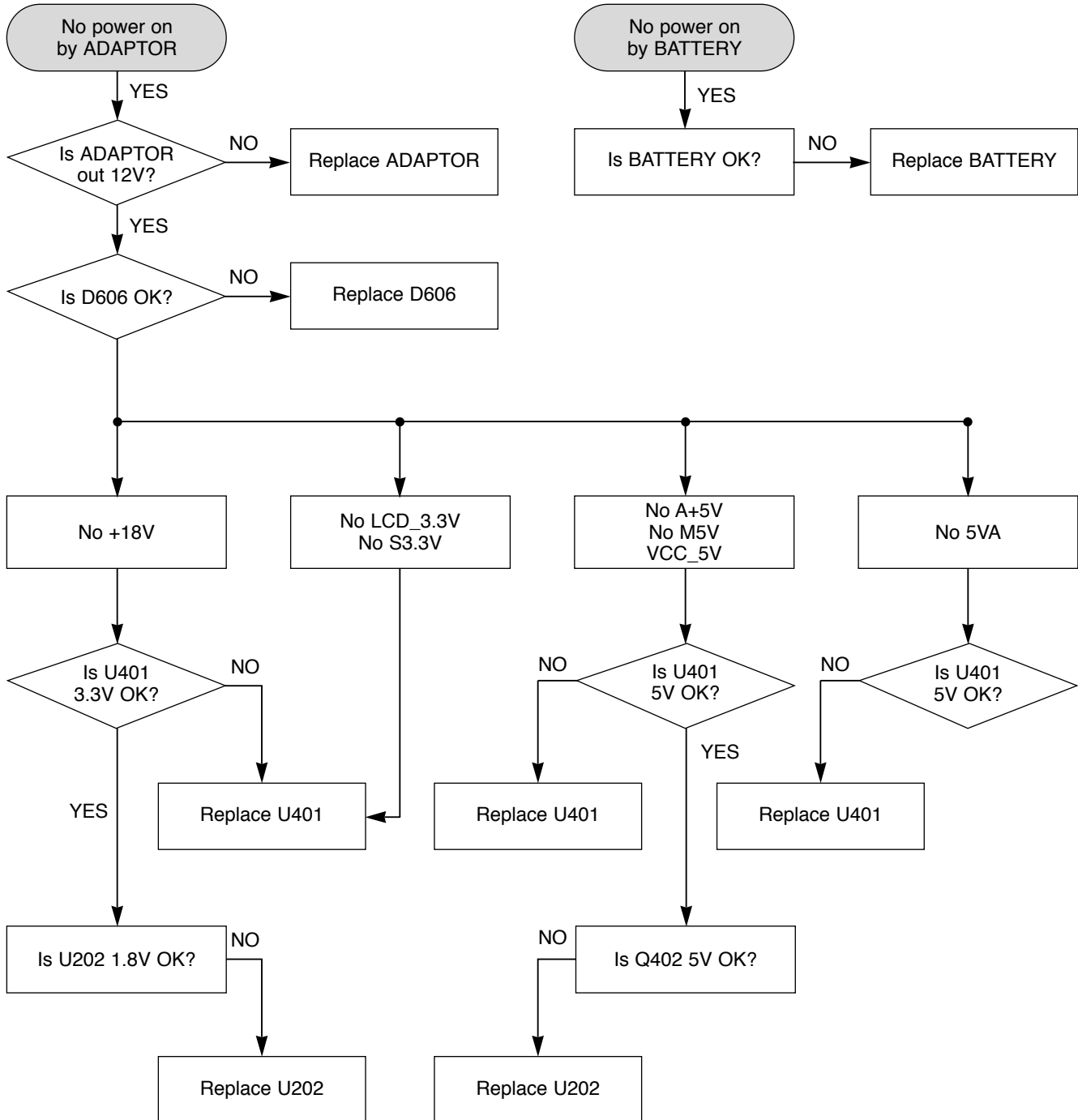

MAIN ELECTRICAL TROUBLESHOOTING GUIDE

C. AUDIO OUT ABNORMAL

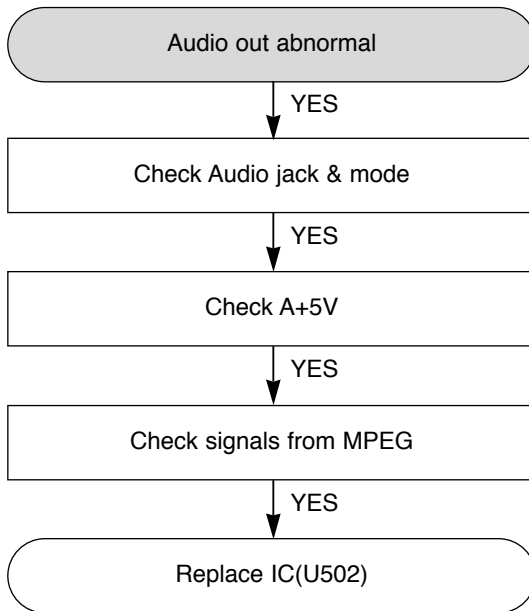

D. VIDEO OUT ABNORMAL

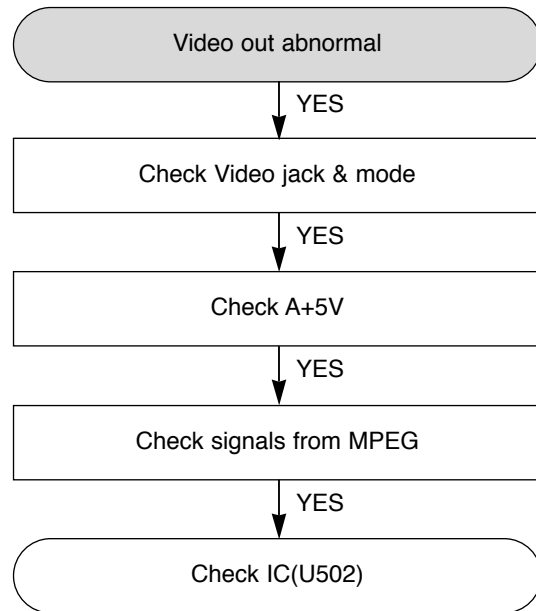

E. PICTURE ABNORMAL

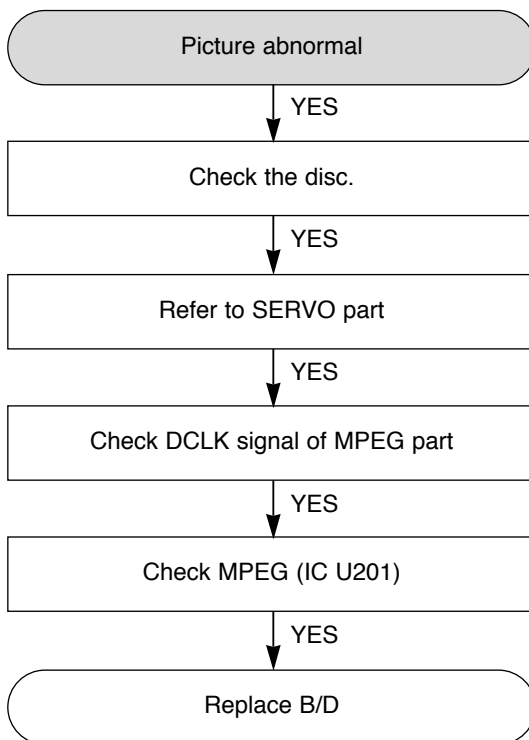

F. DISC ERROR

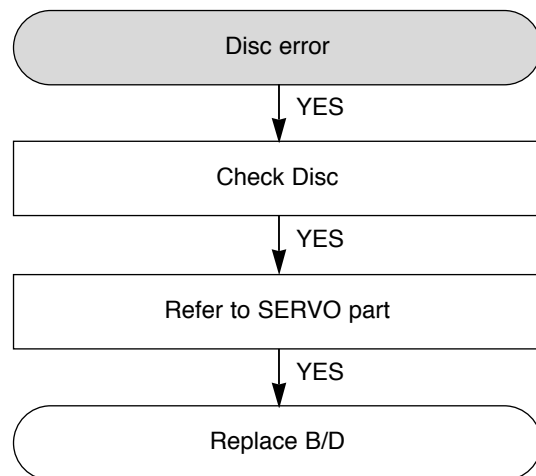

MAIN ELECTRICAL TROUBLESHOOTING GUIDE

G. OPEN/CLOSE ABNORMAL

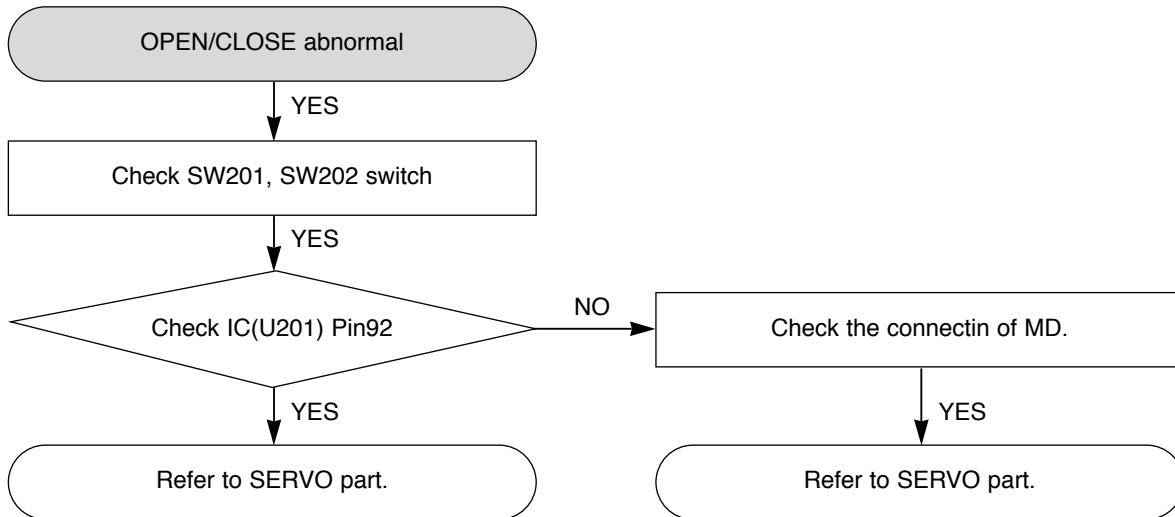

MAIN ELECTRICAL TROUBLESHOOTING GUIDE

2. MPEG CIRCUIT

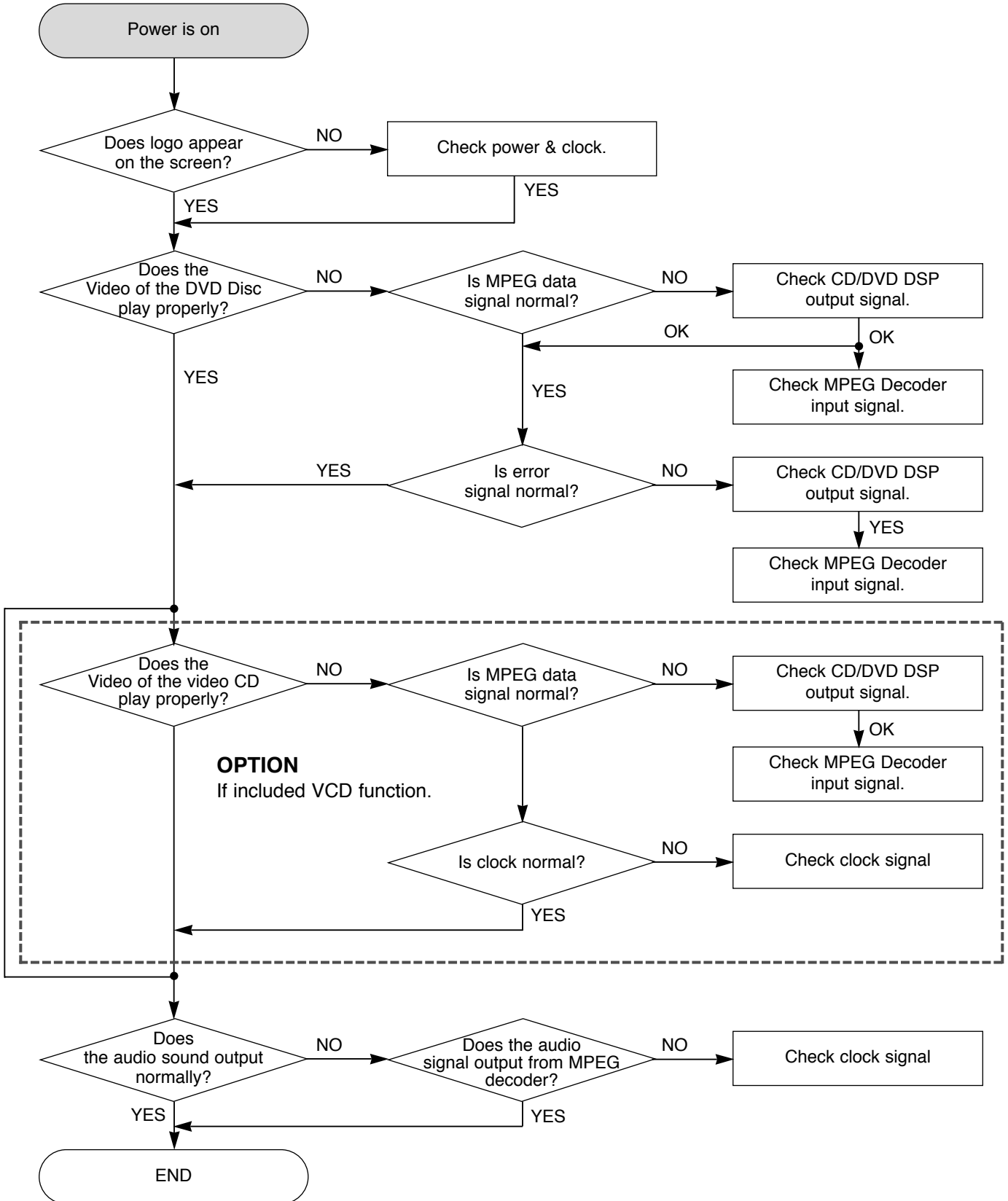

MAIN ELECTRICAL TROUBLESHOOTING GUIDE

3. RF/SERVO CIRCUIT

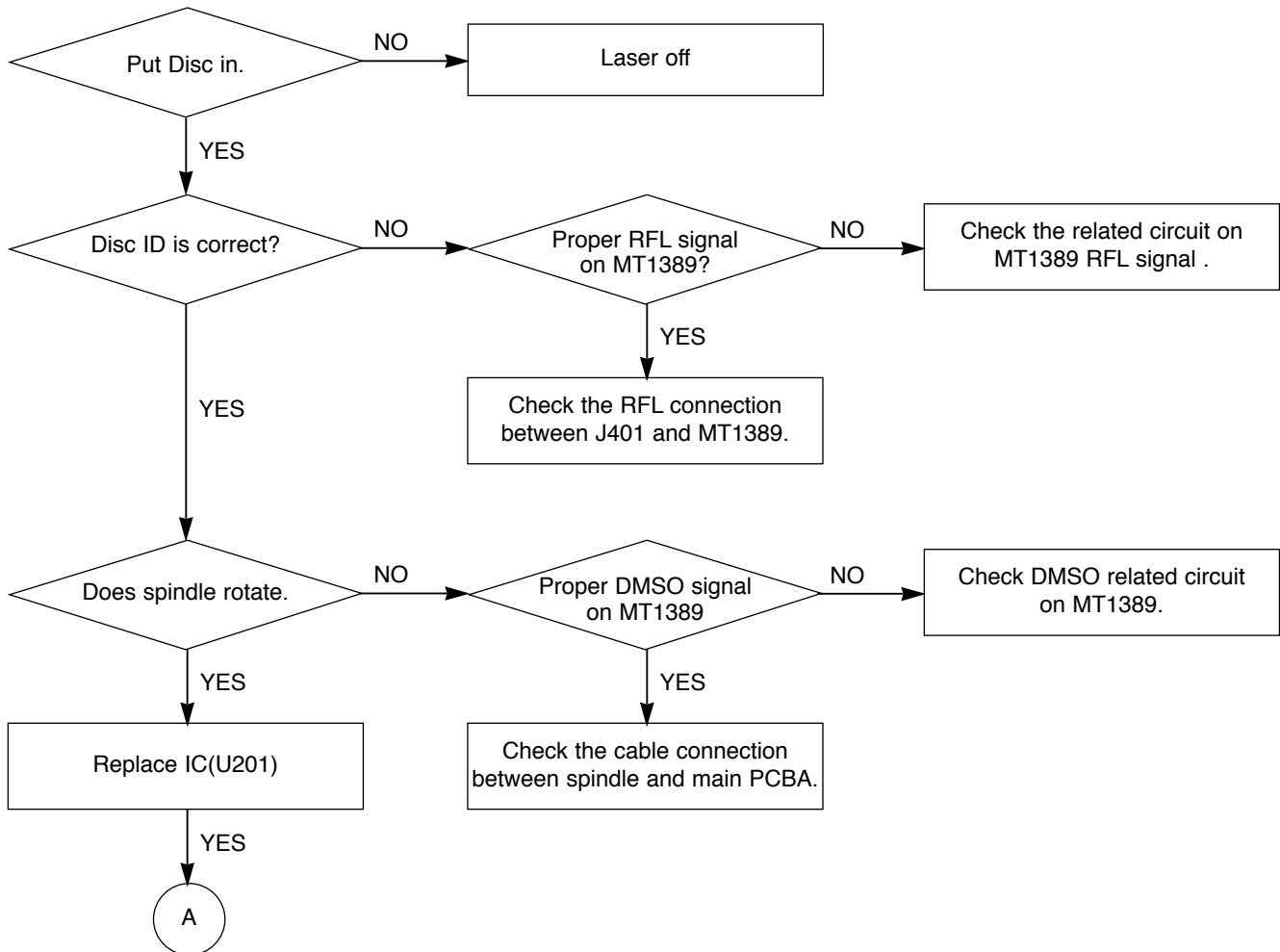

MAIN ELECTRICAL TROUBLESHOOTING GUIDE

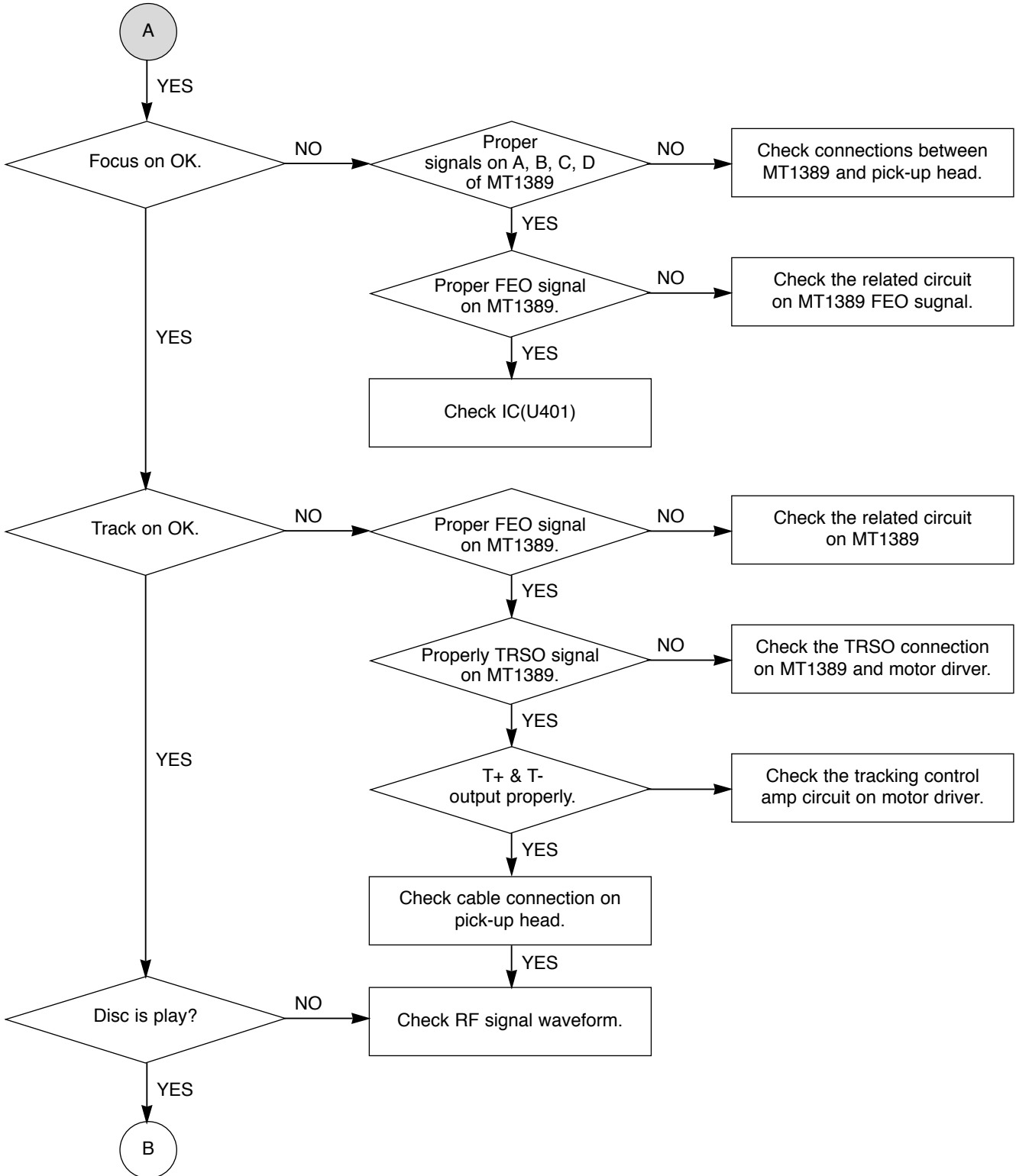

MAIN ELECTRICAL TROUBLESHOOTING GUIDE

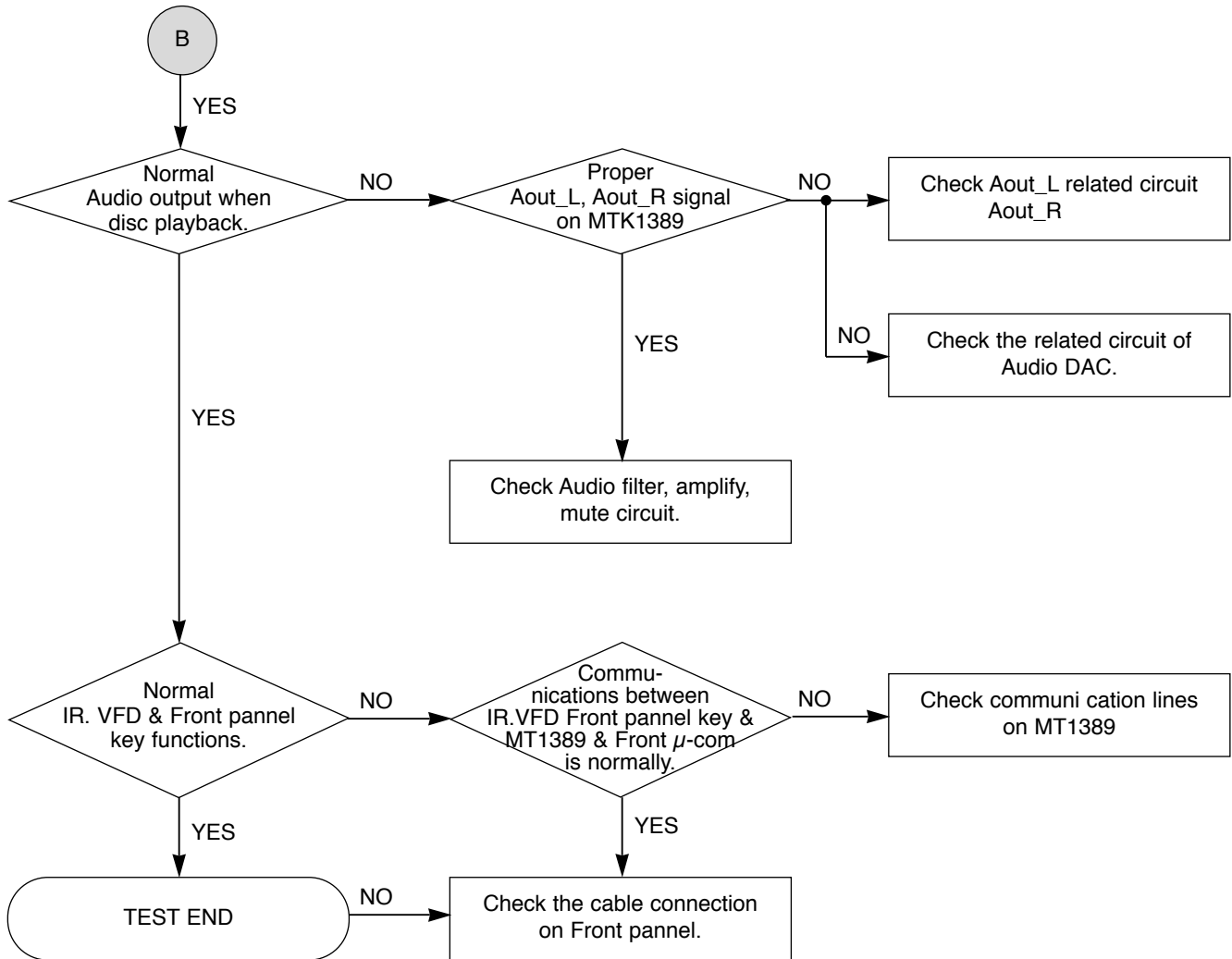

MAIN ELECTRICAL TROUBLESHOOTING GUIDE

4. CHARGING CIRCUIT

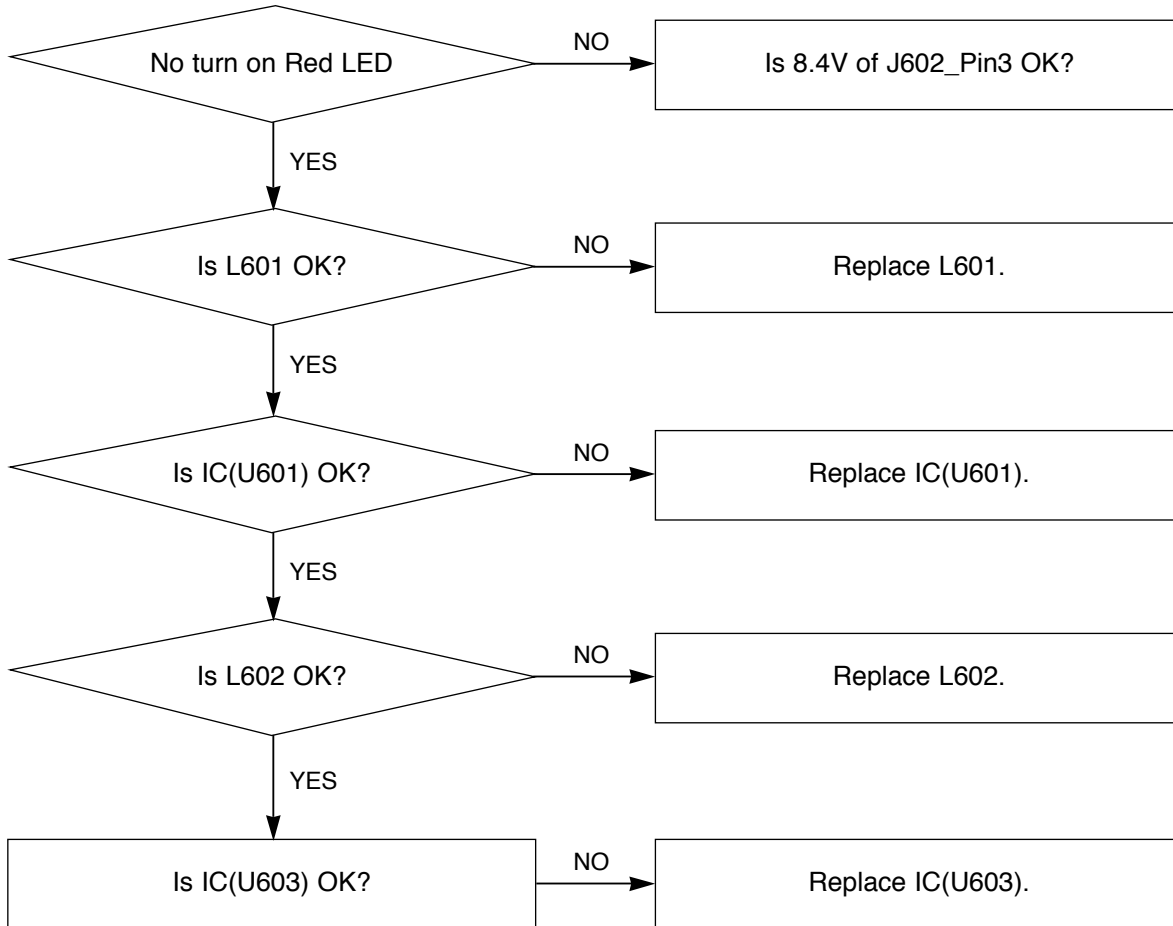

DETAILS AND WAVEFORMS ON SYSTEM TEST AND DEBUGGING

1. SYSTEM 27MHz CLOCK, RESET & FLASH R/W SIGNAL

1) MT1379 main clock is at 27MHz (X201)

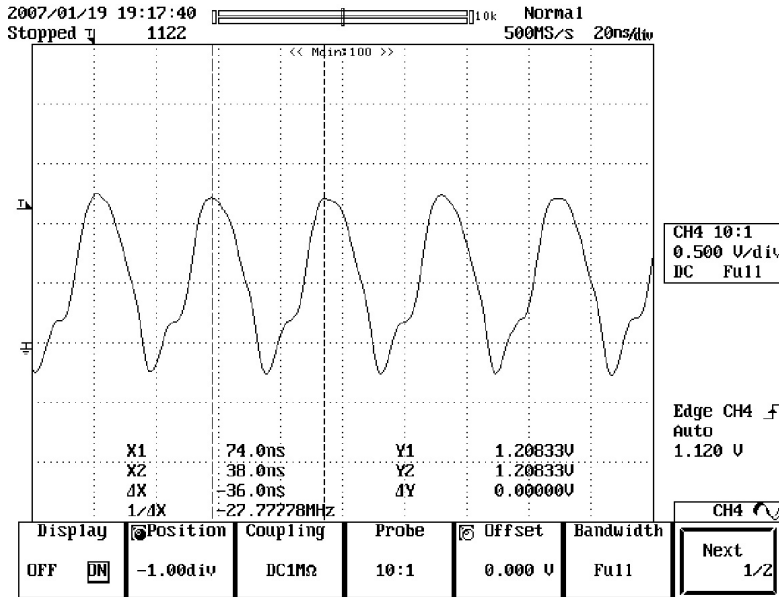

FIG 1-1

2. SDRAM CLOCK

1) MT1389 main clock is at 27MHz (R308)

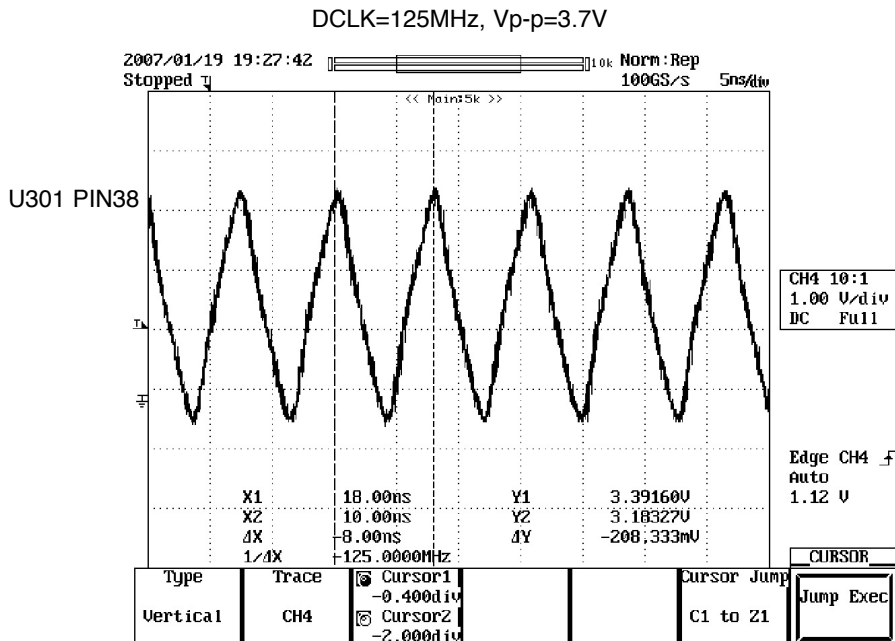

FIG 2-1

3. DISC TYPE JUDGEMENT WAVEFORM

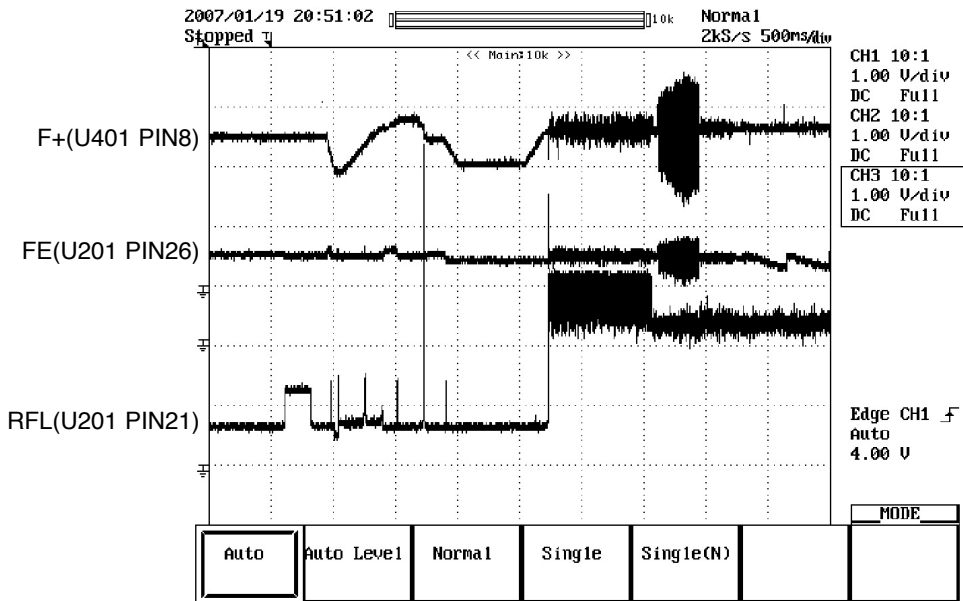

FIG 3-1

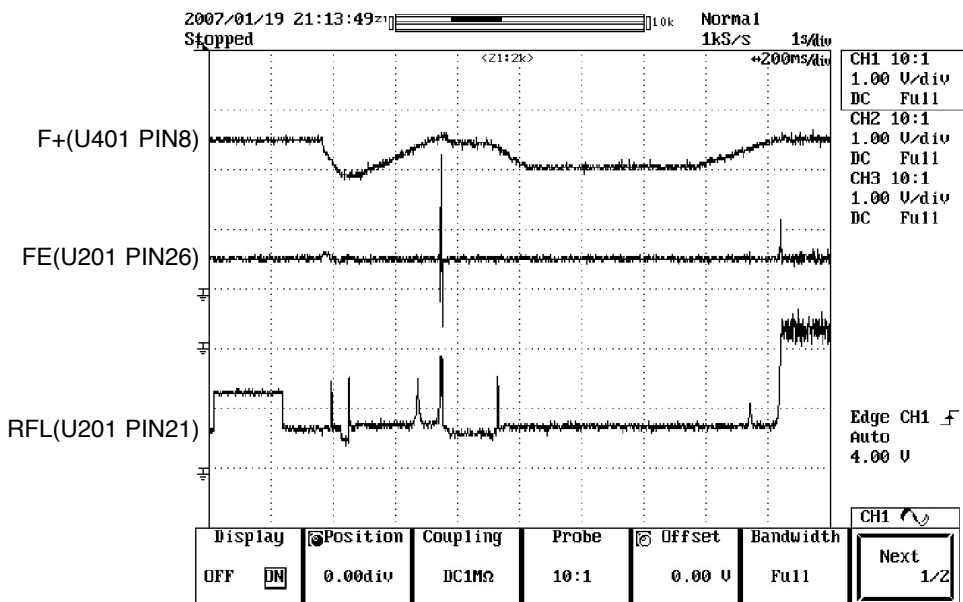

FIG 3-2

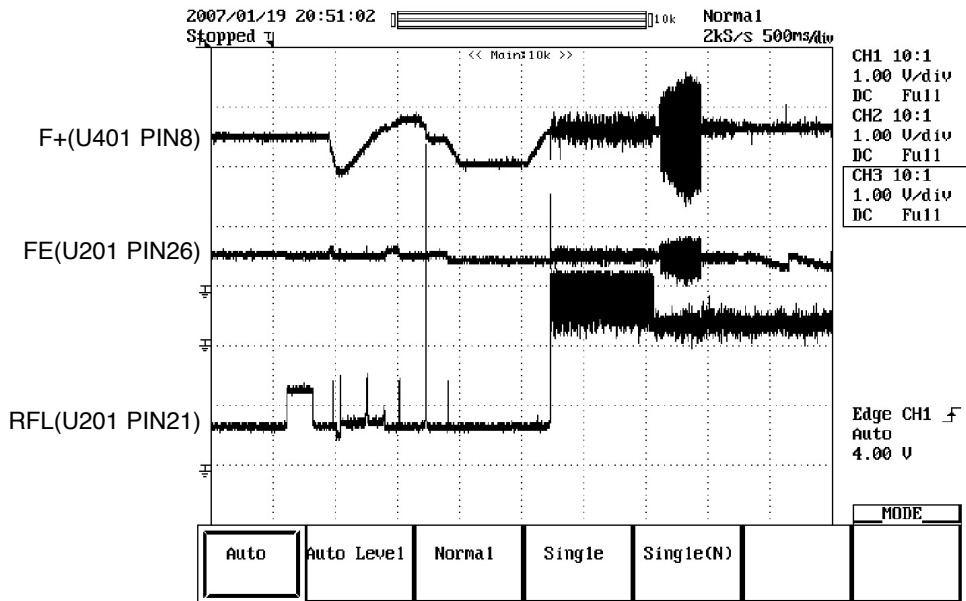

FIG 3-3

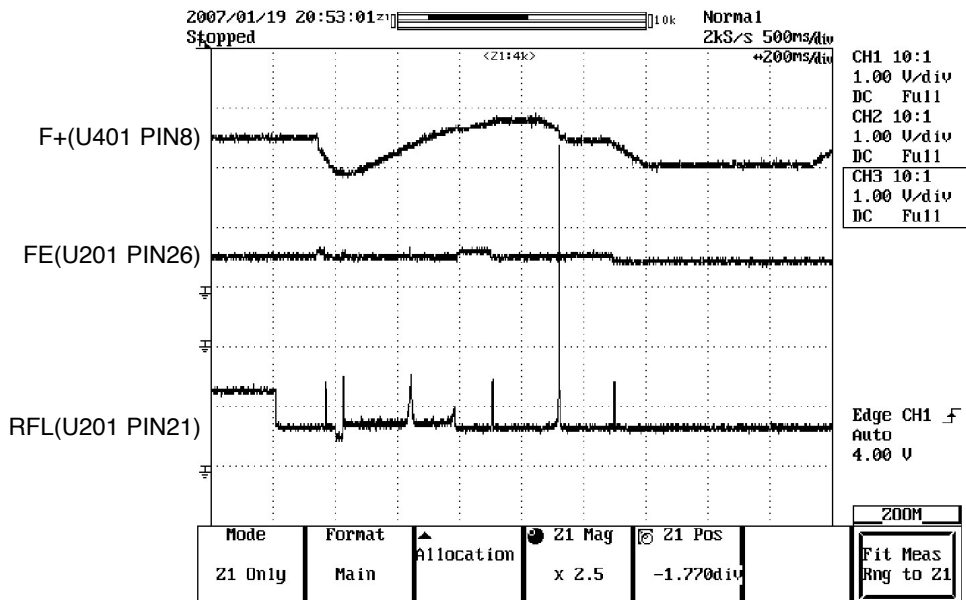

FIG 3-4

4. FOCUS ON WAVEFORM

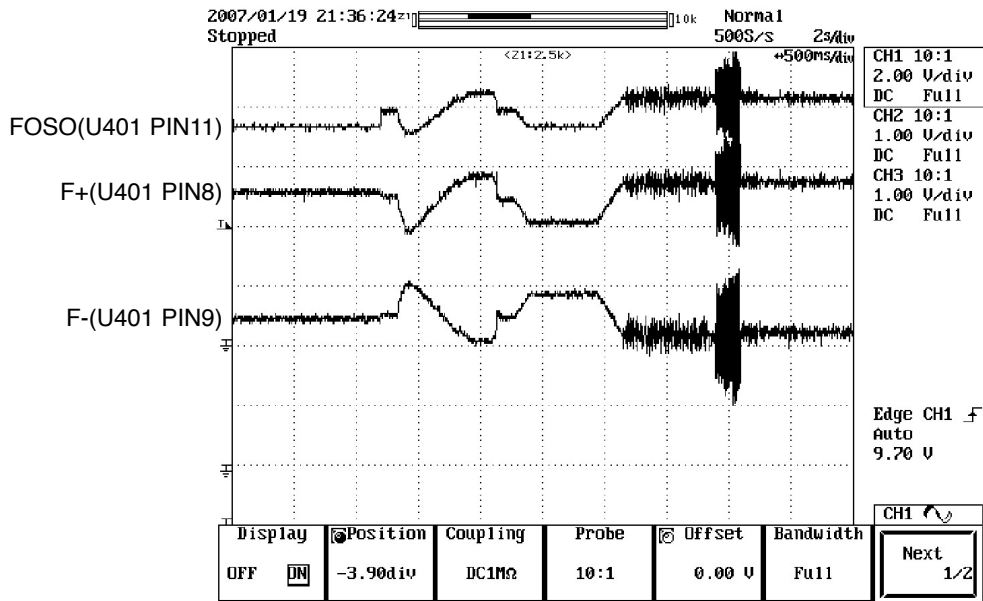

FIG 4-1

5. SPINDLE CONTROL WAVEFORM (NO DISC CONDITION)

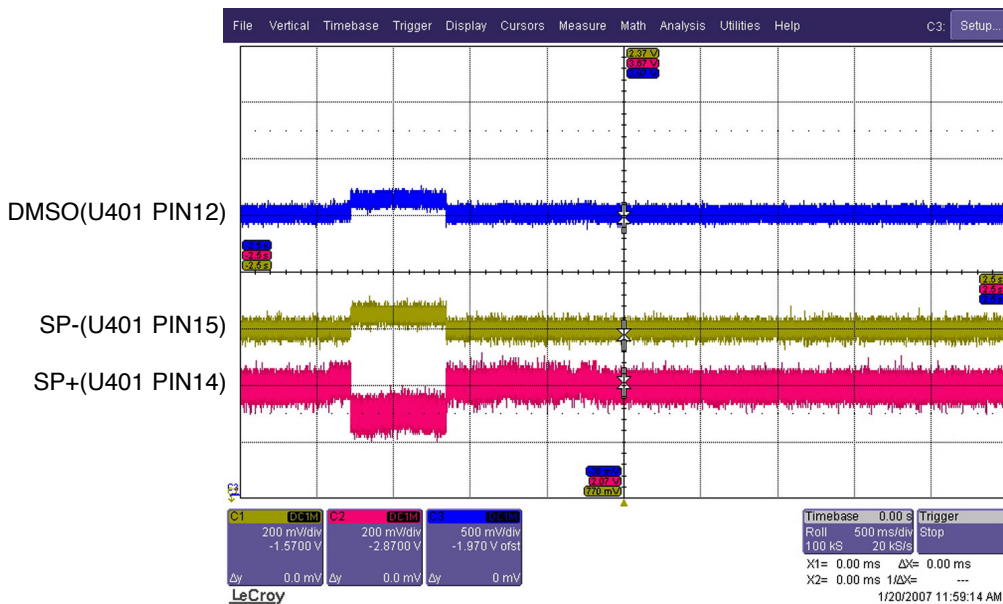

FIG 5-1

6. TRACKING CONTROL RELATED SIGNAL (SYSTEM CHECKING)

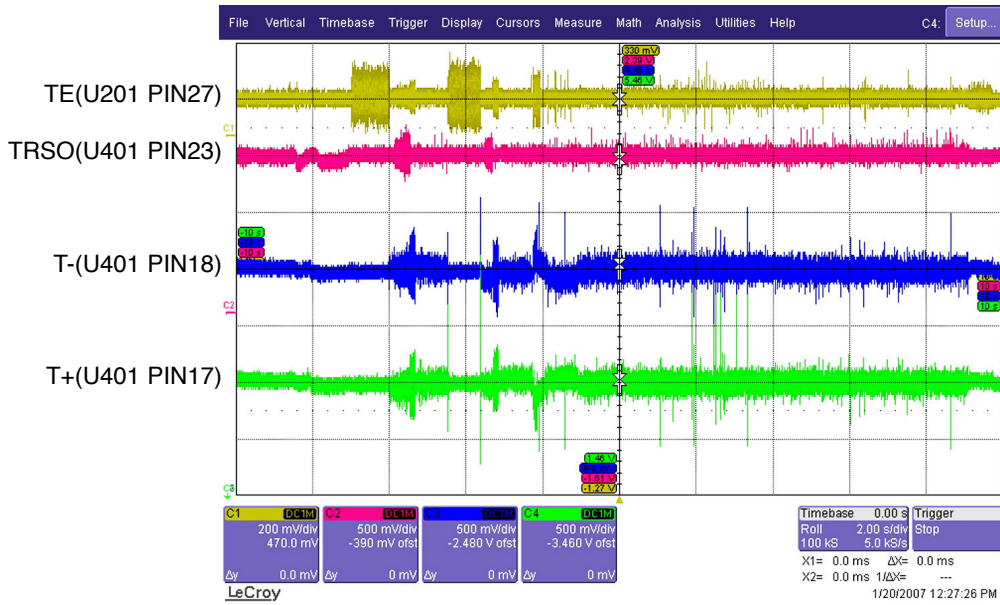

FIG 6-1

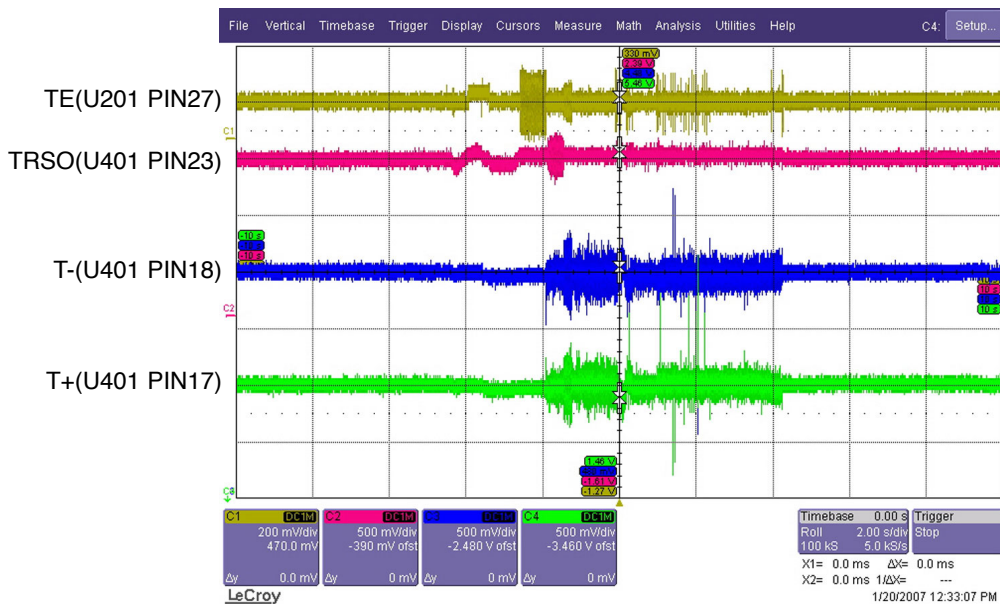

FIG 6-2

7. MT1389 AUDIO OPTICAL AND COAXIAL OUTPUT (ASPDIF)

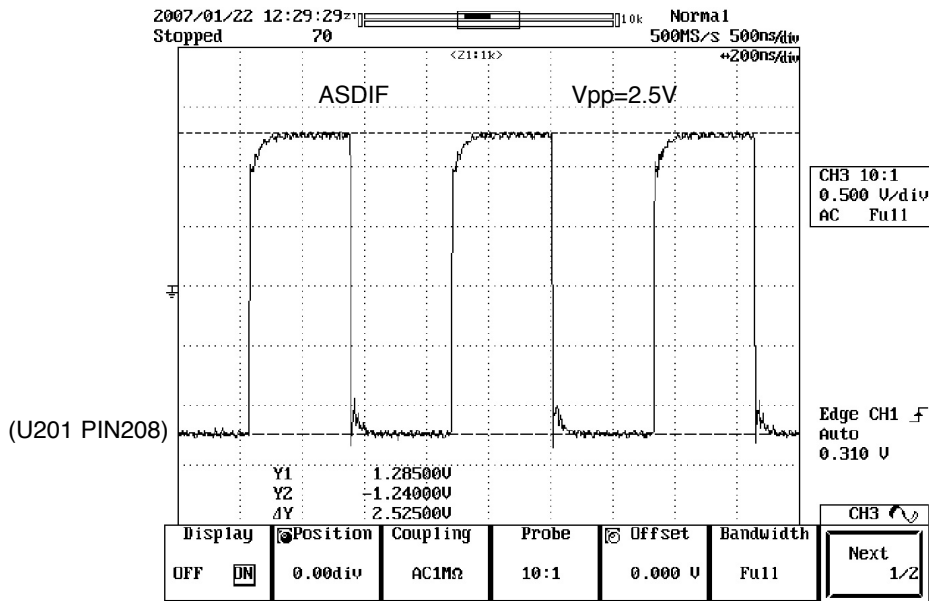

FIG 7-1

8. MT1389 VIDEO OUTPUT WAVEFORM

1) Full colorbar signal (CVBS)

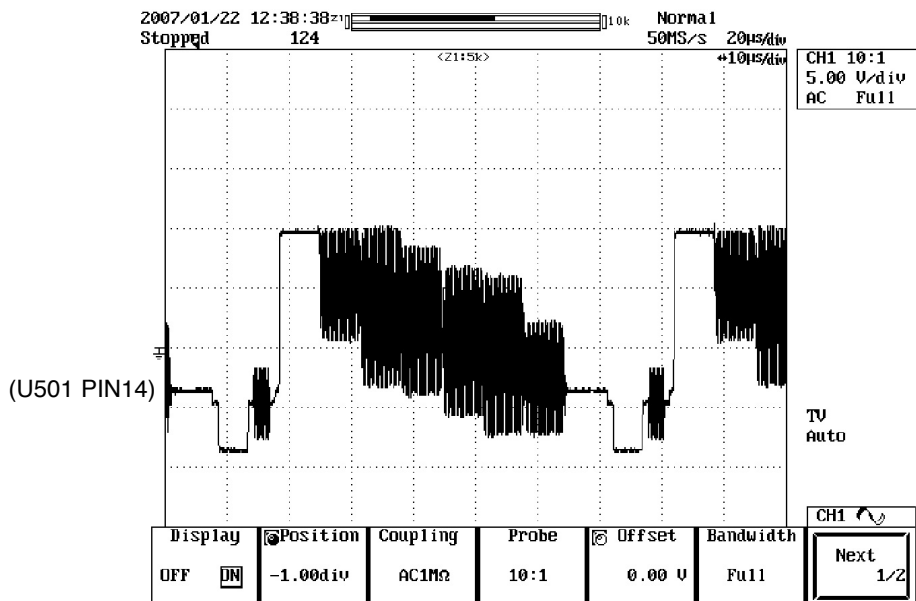

FIG 8-1

9. AUDIO OUTPUT FROM AUDIO DAC

1) Audio L/R

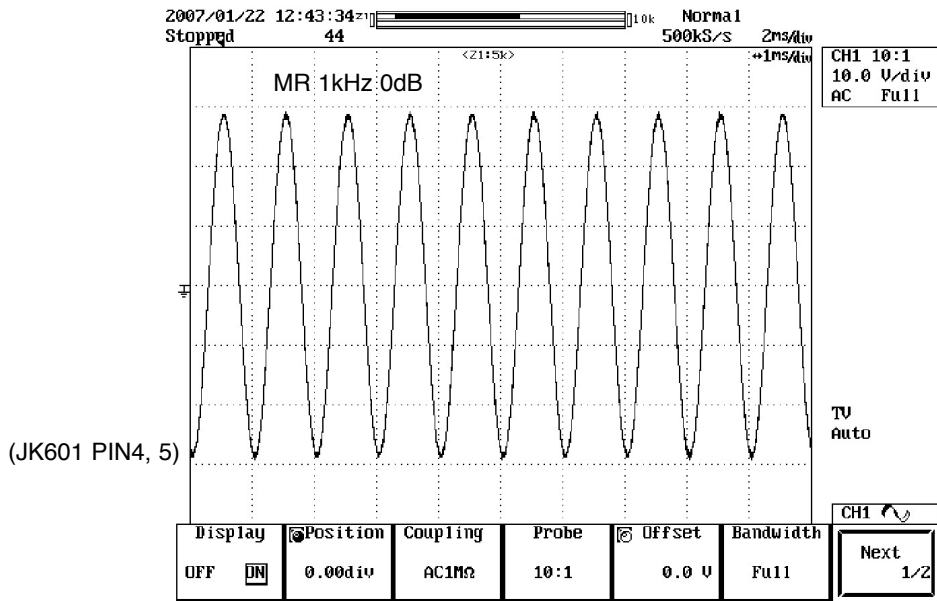

FIG 9-1

2) Audio related Signal

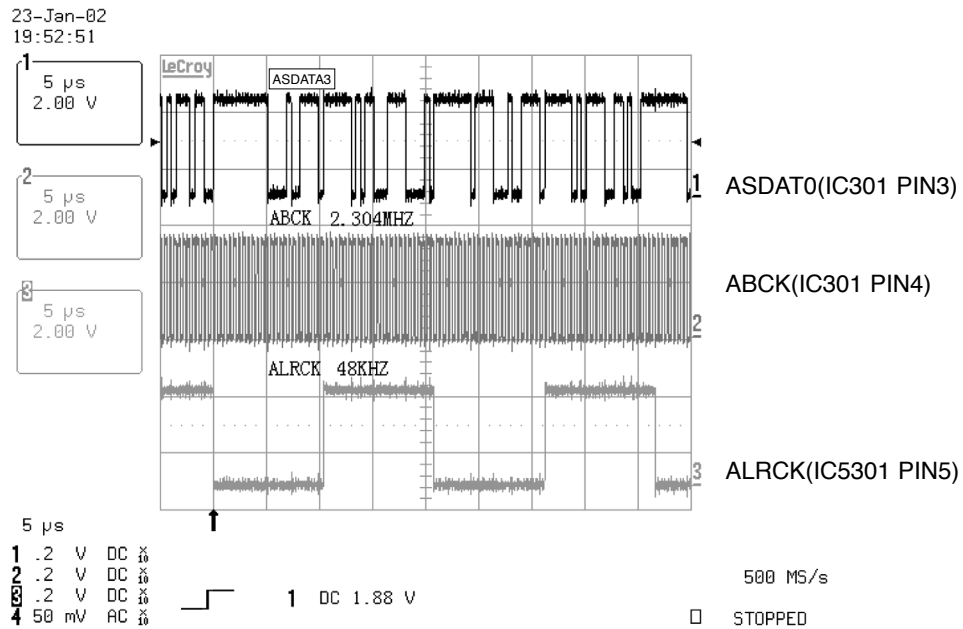
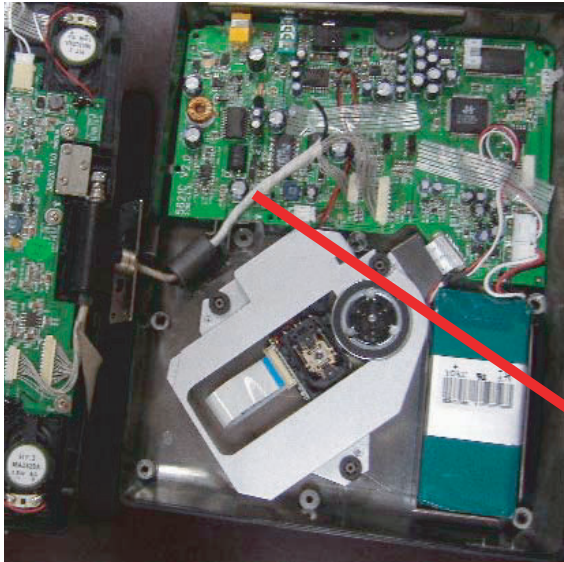

FIG 9-2

WIRING CONNECTION DIAGRAMS

1. WIRING CONNECTION DIAGRAMS-1

MAIN PCB



LCD PCB

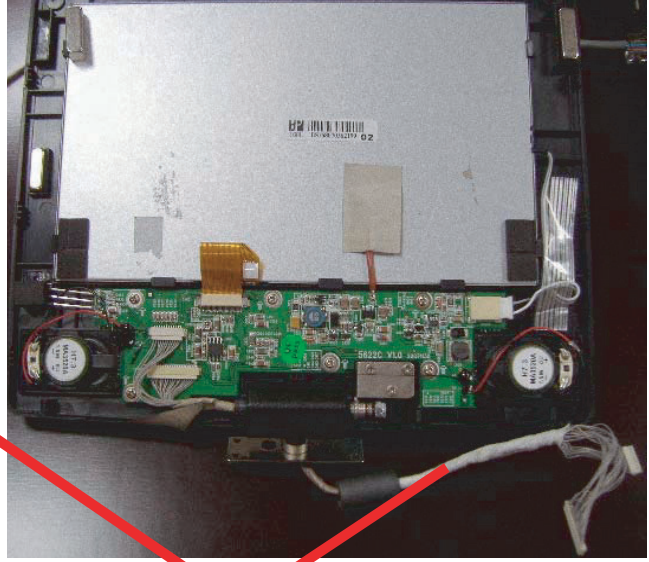

(MAIN PCB <----> LCD PCB)

0.8-12Y-12Y-220mm
0.8-20Y-20Y-220mm

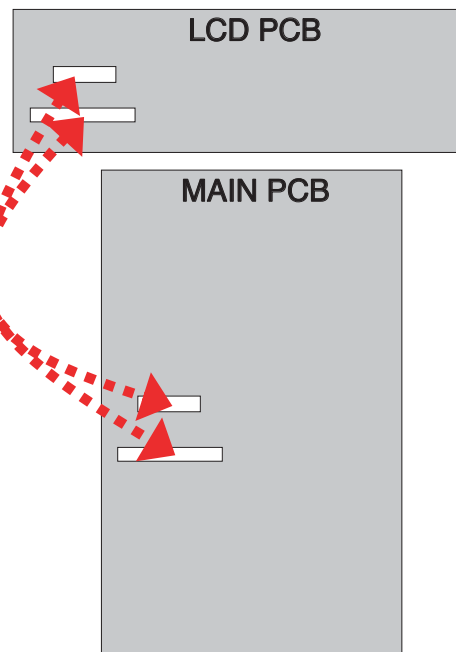

2. WIRING CONNECTION DIAGRAMS-2

(MAIN PCB <----> KEY PCB)

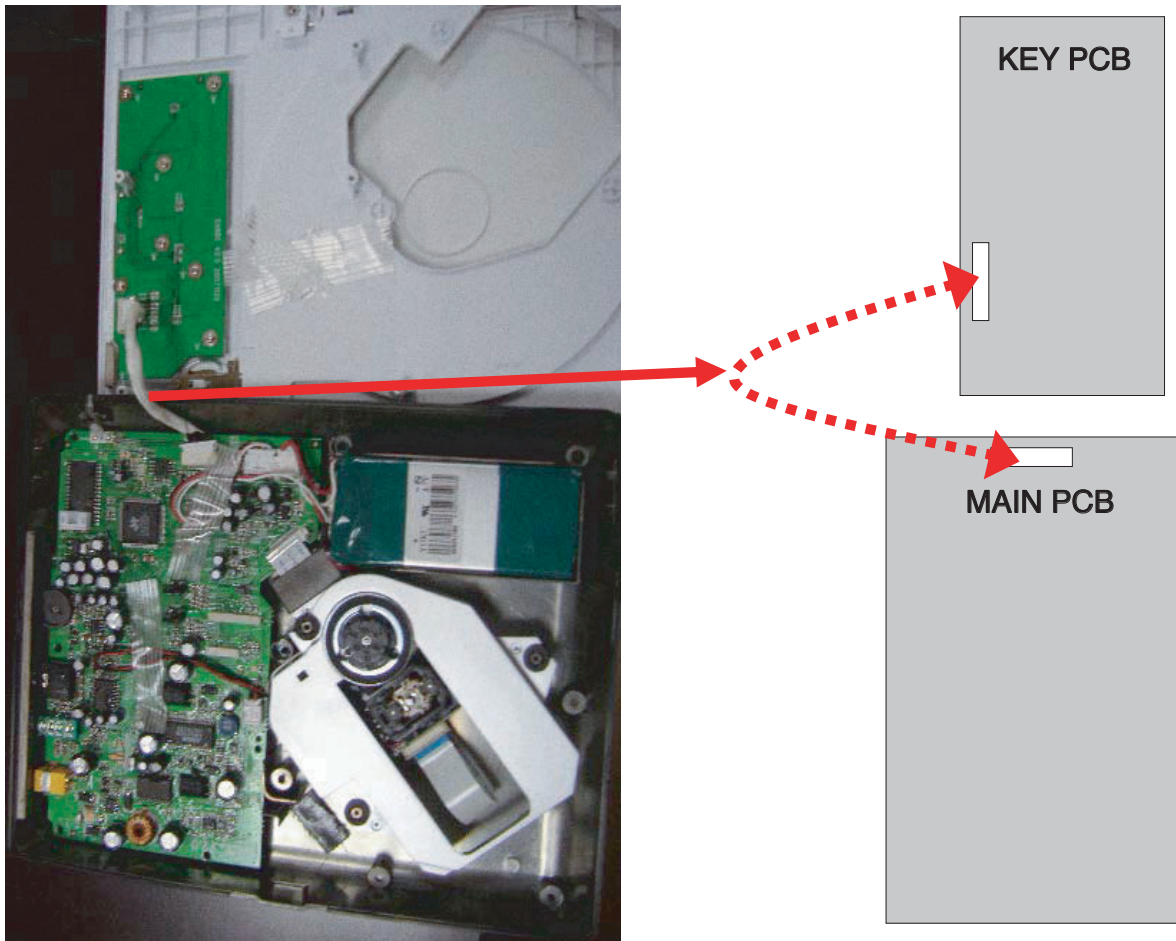

KEY PCB

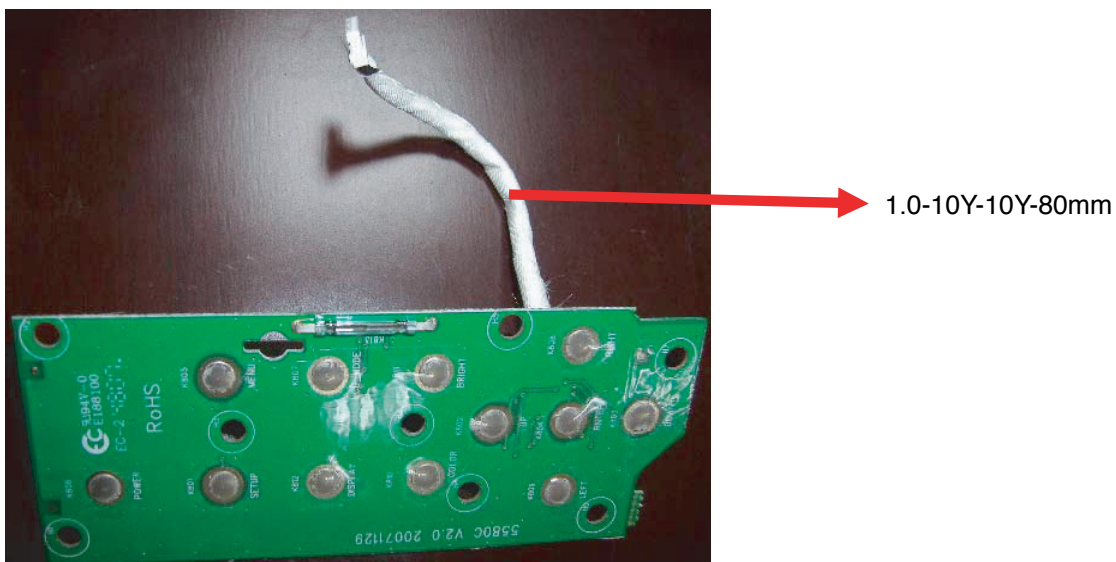

MEMO

A series of horizontal dotted lines for writing.

BLOCK DIAGRAMS

1. OVERALL BLOCK DIAGRAM

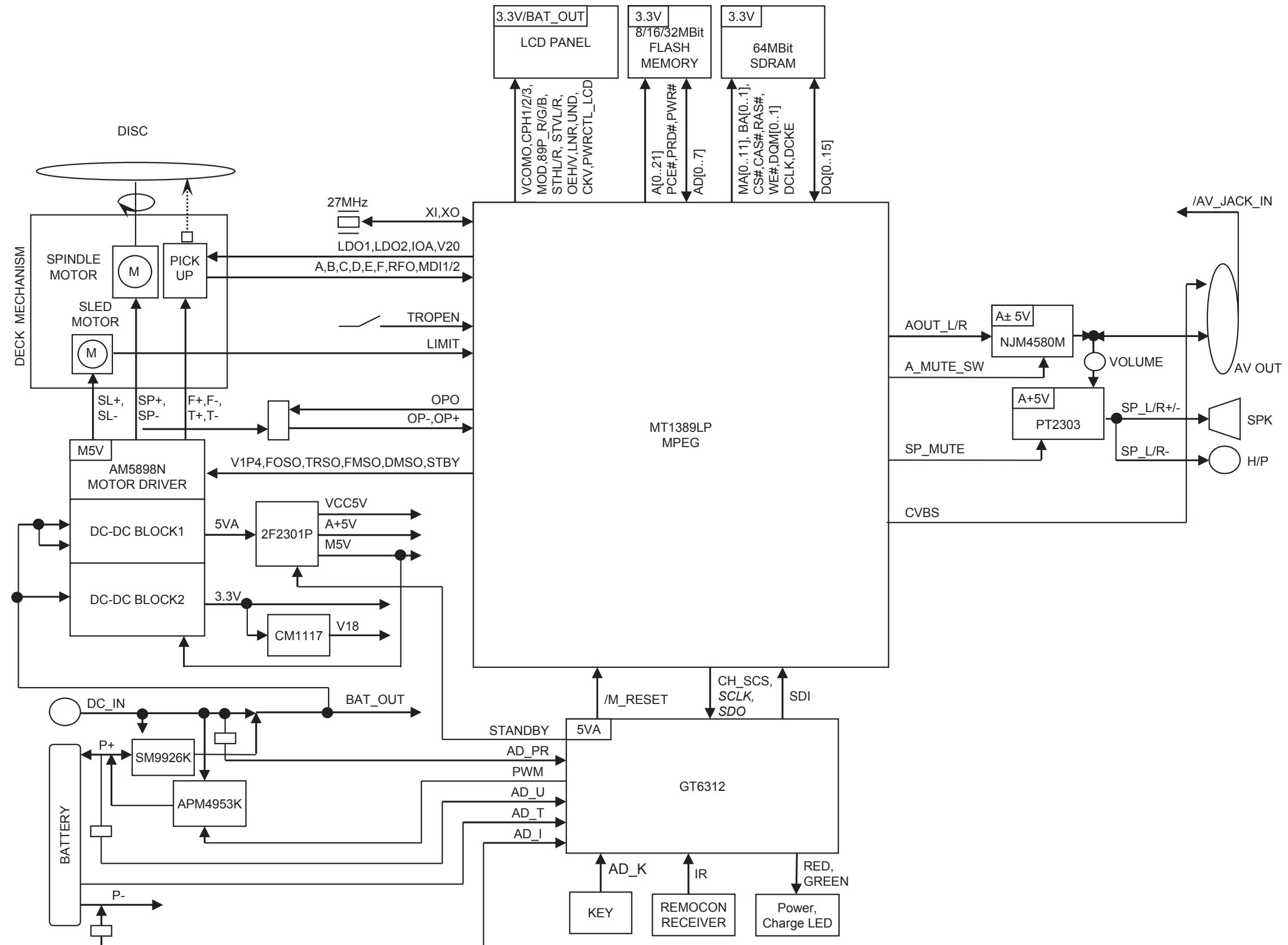

2. POWER BLOCK DIAGRAM

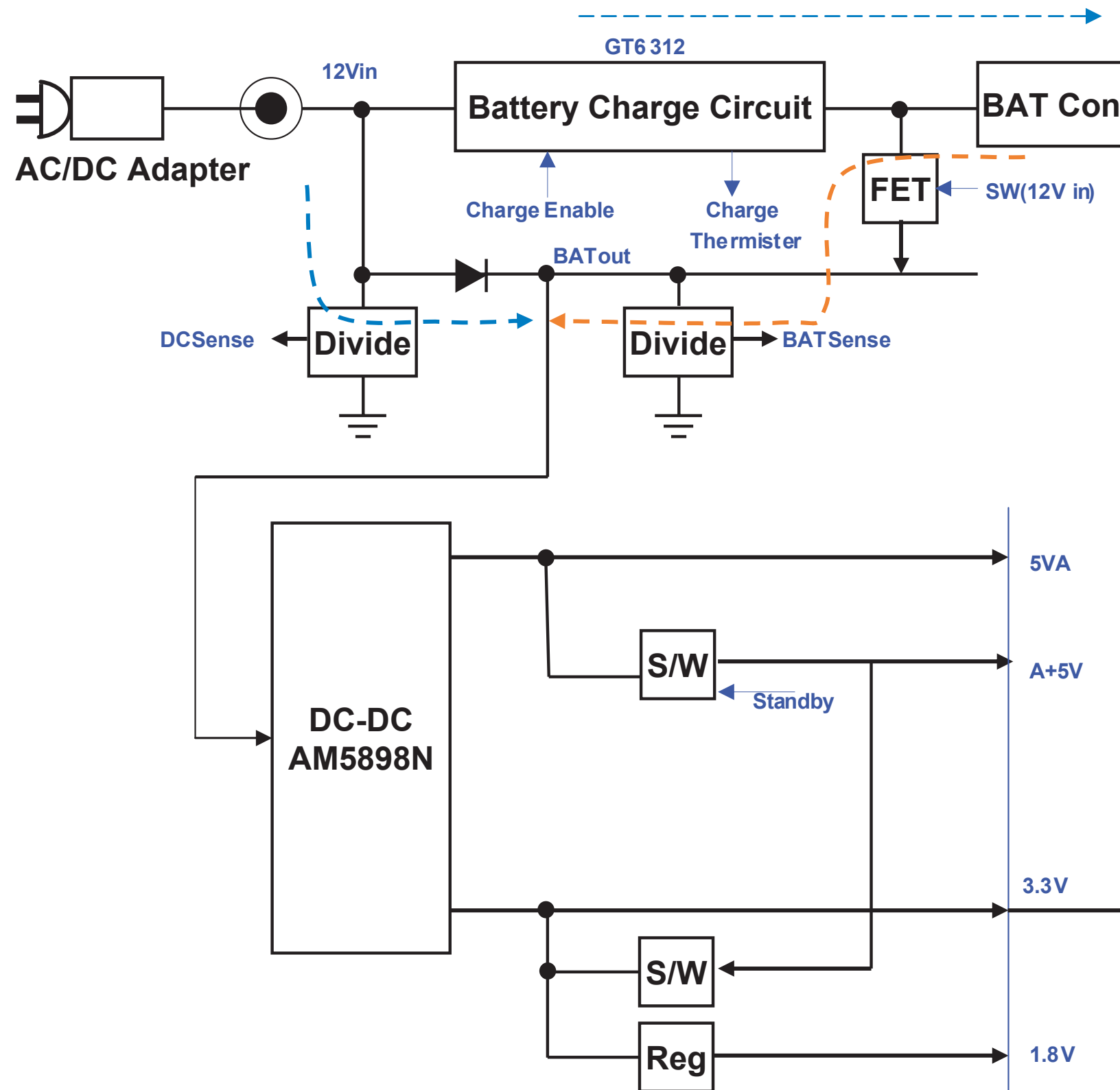

---> Charge
 ---> Discharge

5VA	REMOCON RECEIVER
M5V	Servo
A+5V Battery out	Video Audio
A+5V 3.3V 1.8V	System
7.5V -10V 15V 5VD	LCD Panel

3. SERVO BLOCK DIAGRAM

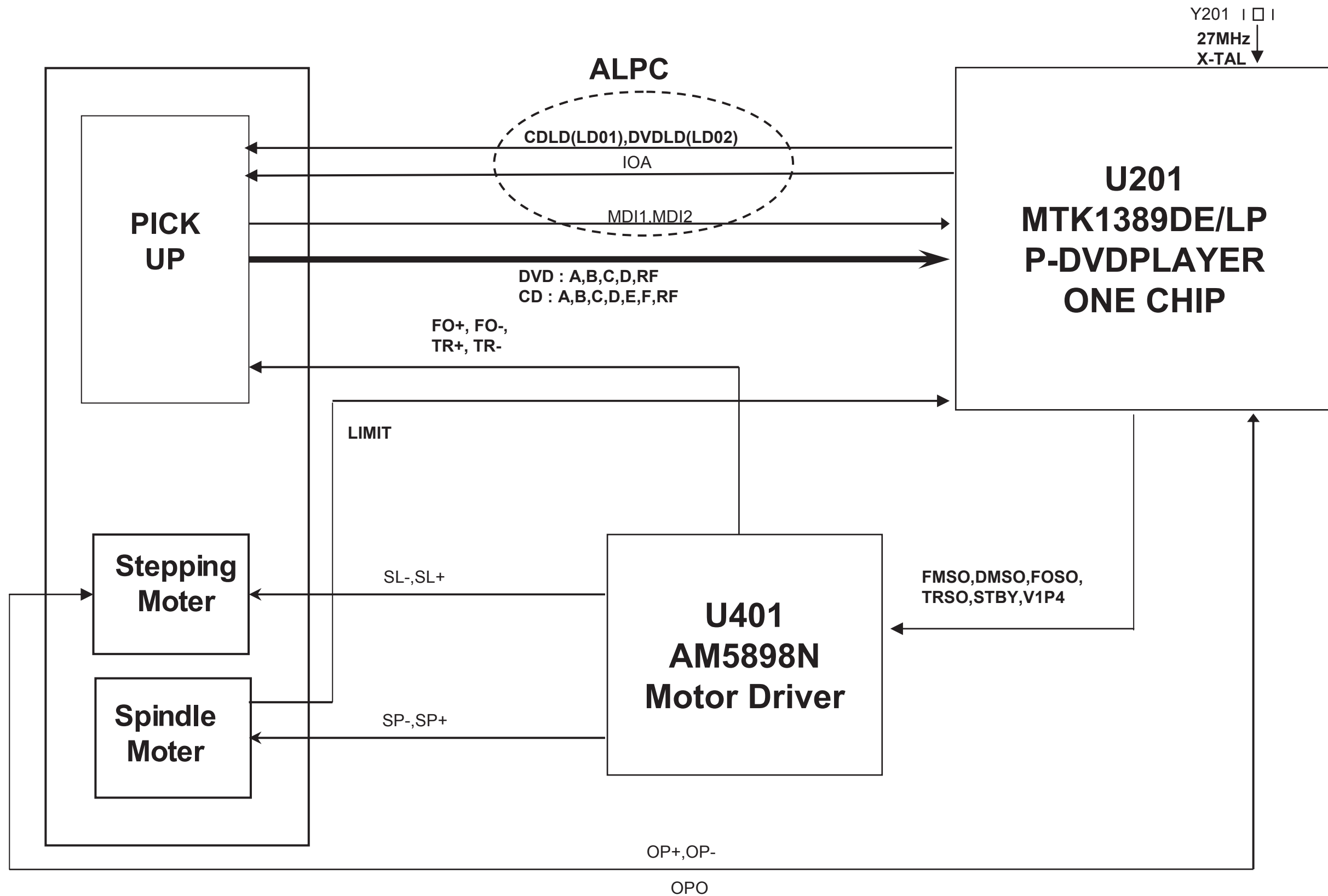

4. SYSTEM BLOCK DIAGRAM

System & AV Part

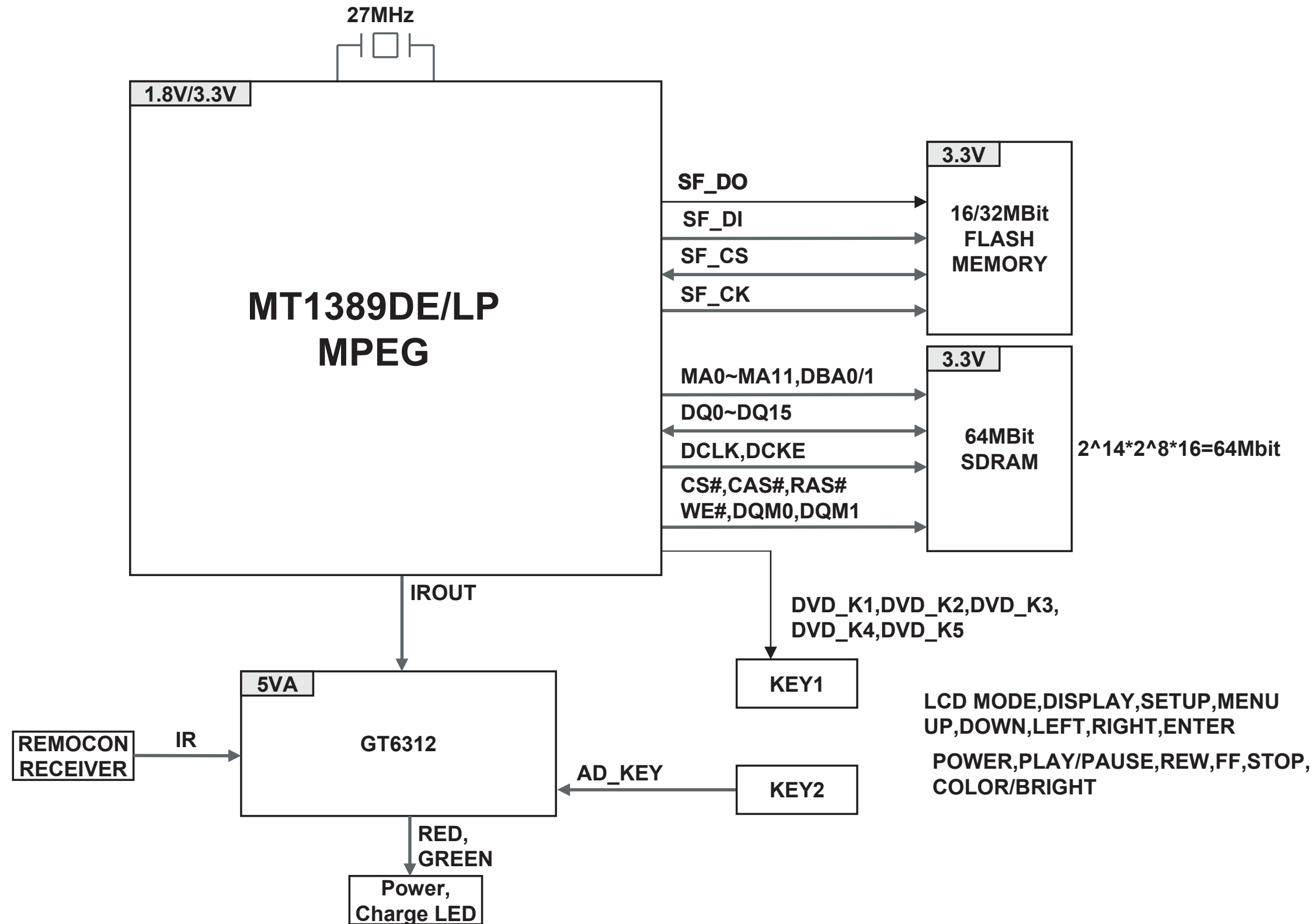

5. AV BLOCK DIAGRAM

System & AV Part

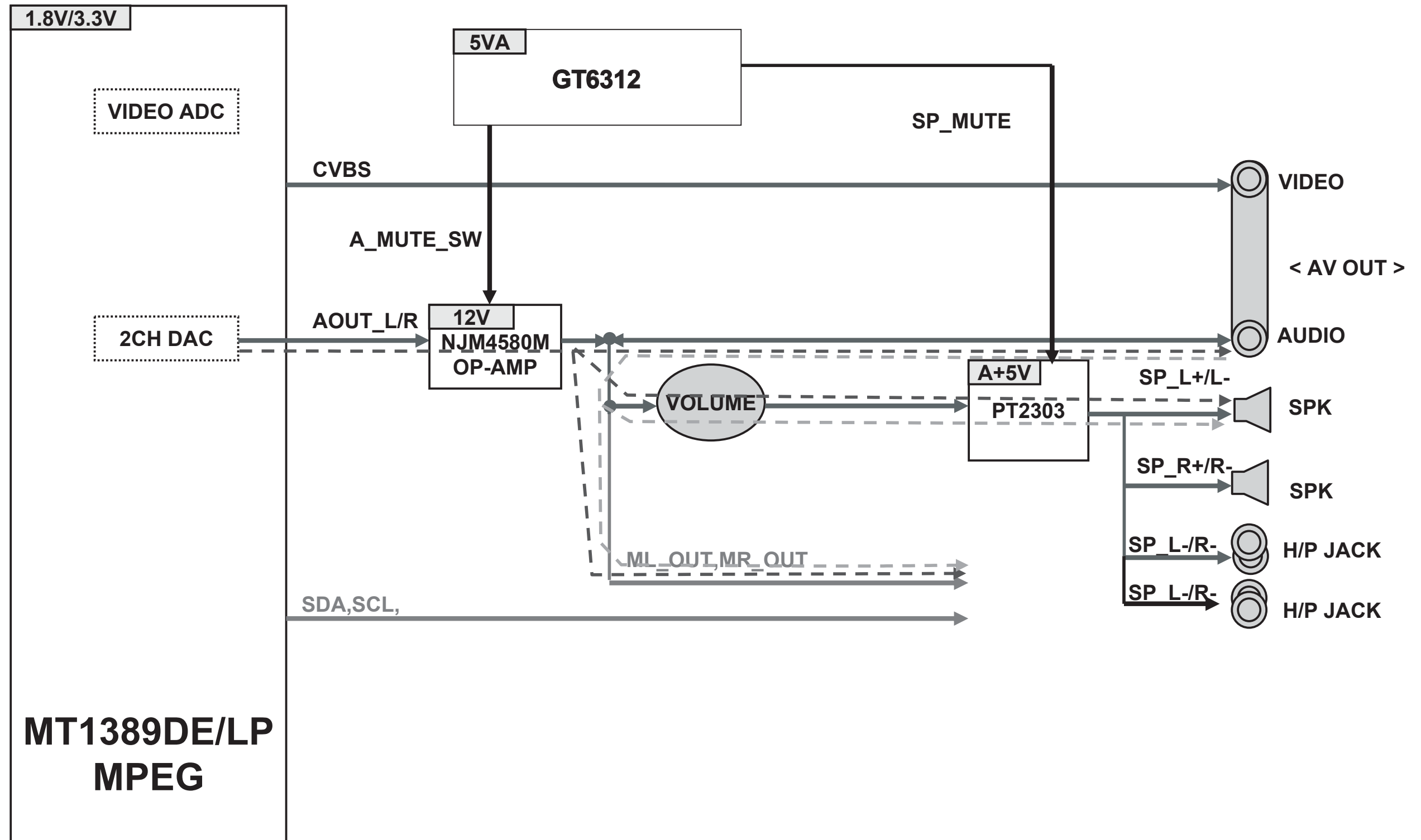

CIRCUIT DIAGRAMS

1. MPEG CIRCUIT DIAGRAM

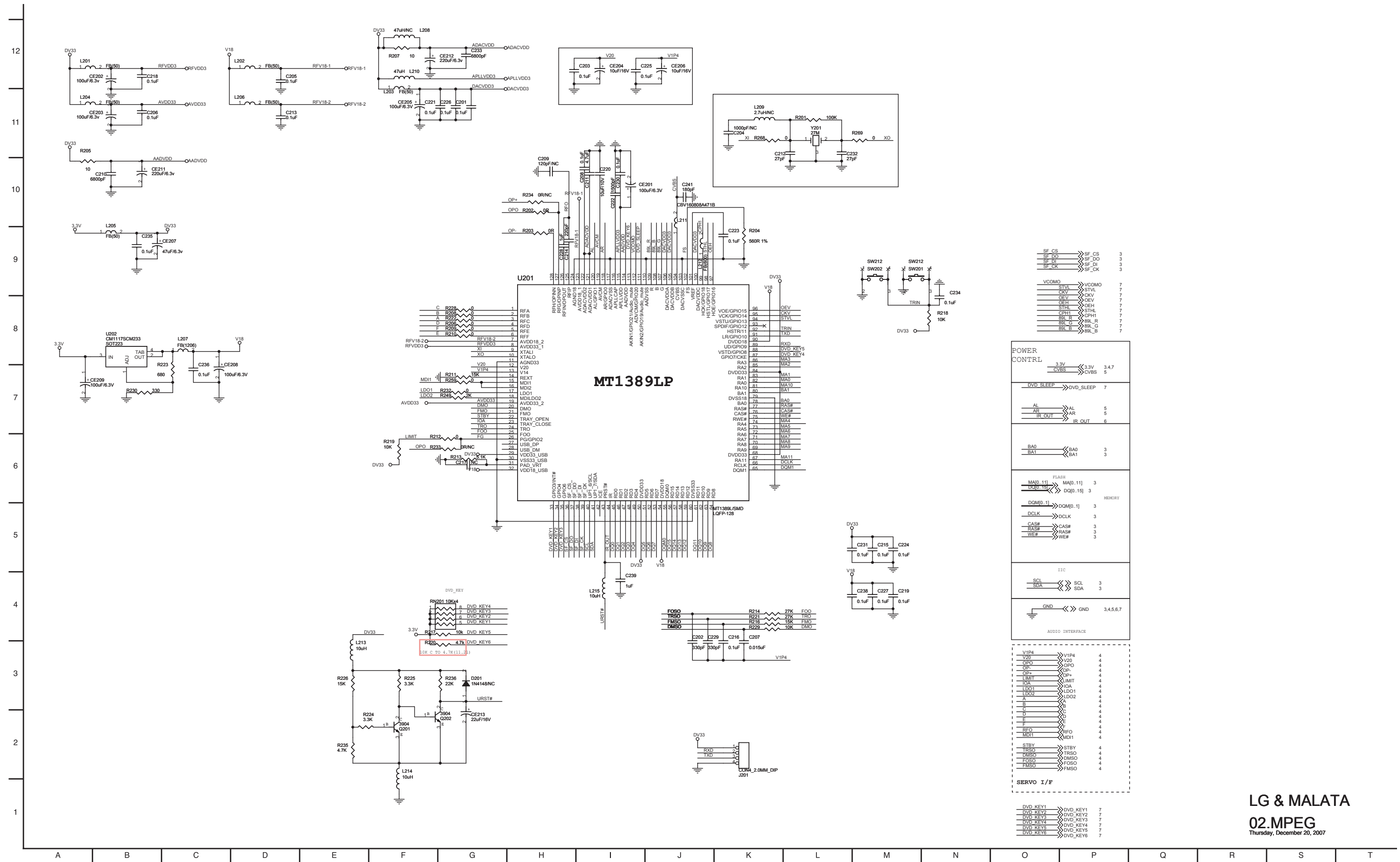

2. MEMORY CIRCUIT DIAGRAM

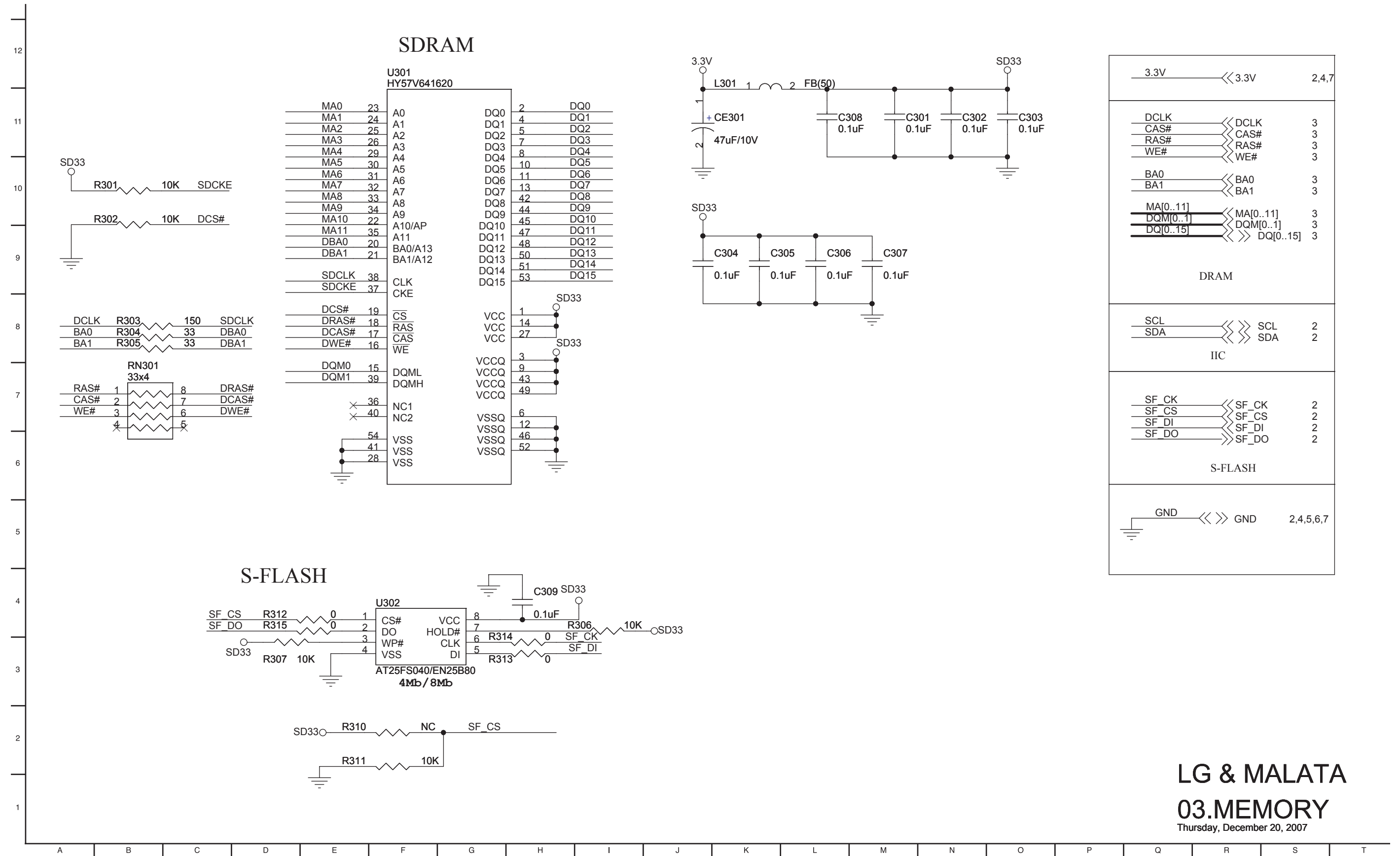

LG & MALATA

03.MEMORY

Thursday, December 20, 2007

3. OPU & MOTOR CIRCUIT DIAGRAM

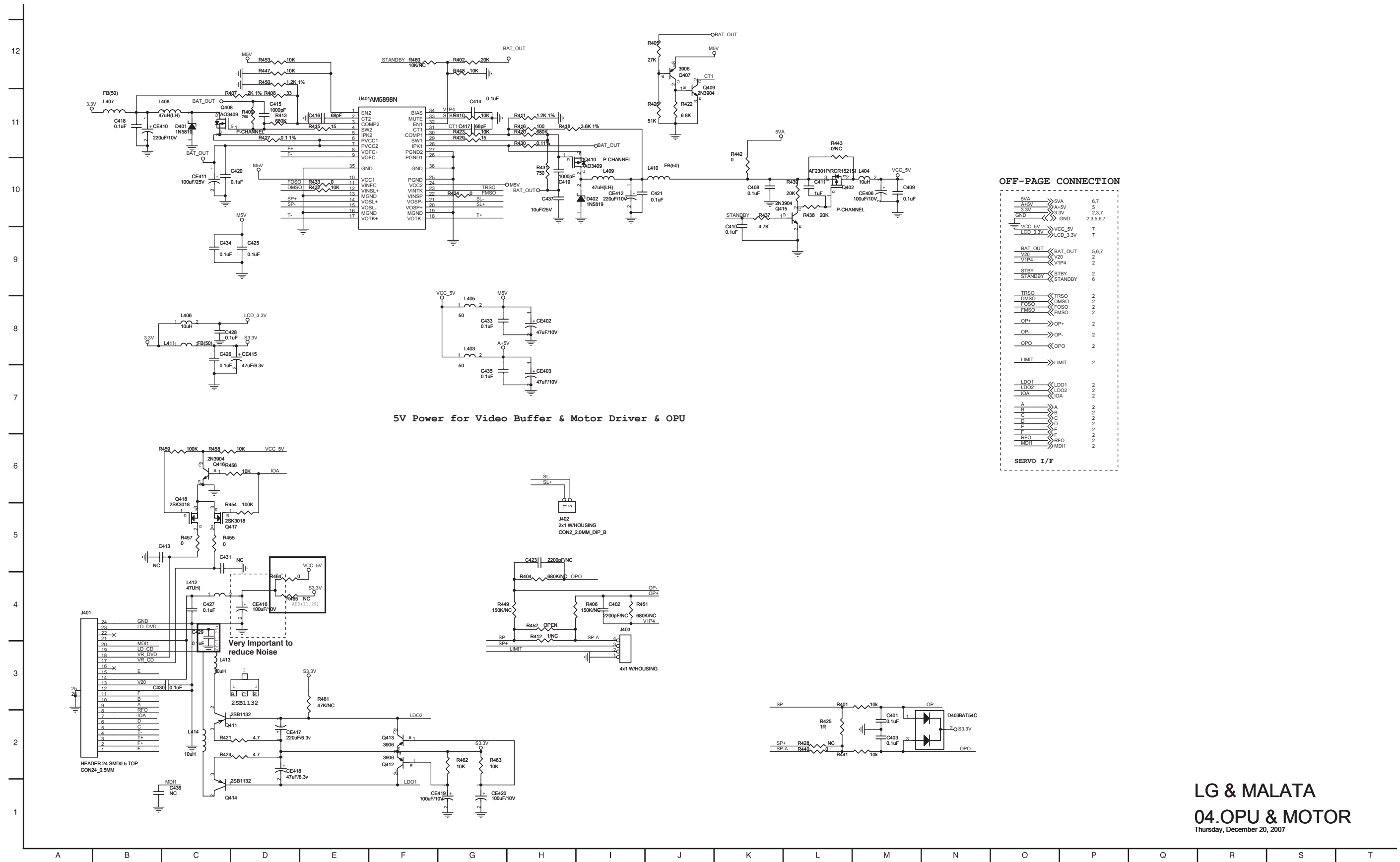

LG & MALATA
04.OPU & MOTOR
 Thursday, December 20, 2007

4. AV CIRCUIT DIAGRAM

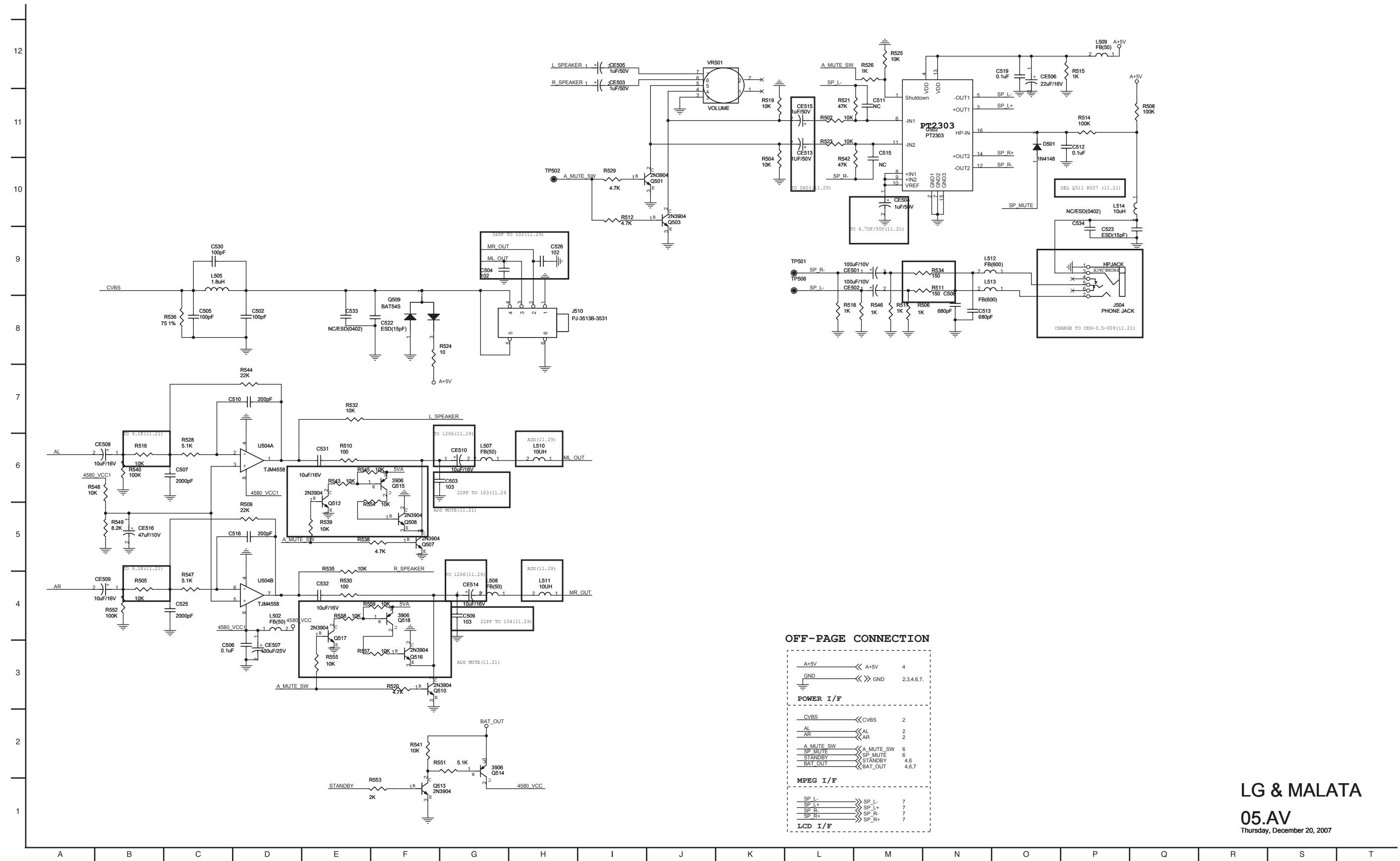

OFF-PAGE CONNECTION

A+5V	← A+5V	4
GND	← GND	2,3,4,6,7
POWER I/F		
CVBS	← CVBS	2
AL	← AL	2
AR	← AR	2
A MUTE SW	← A MUTE SW	6
SP MUTE	← SP MUTE	6
STANDBY	← STANDBY	4,6
BAT_OUT	← BAT_OUT	4,6,7
MPEG I/F		
SP L-	← SP L-	7
SP L+	← SP L+	7
SP R-	← SP R-	7
SP R+	← SP R+	7
LCD I/F		

LG & MALATA
05.AV
 Thursday, December 20, 2007

5. CHARGE CIRCUIT DIAGRAM

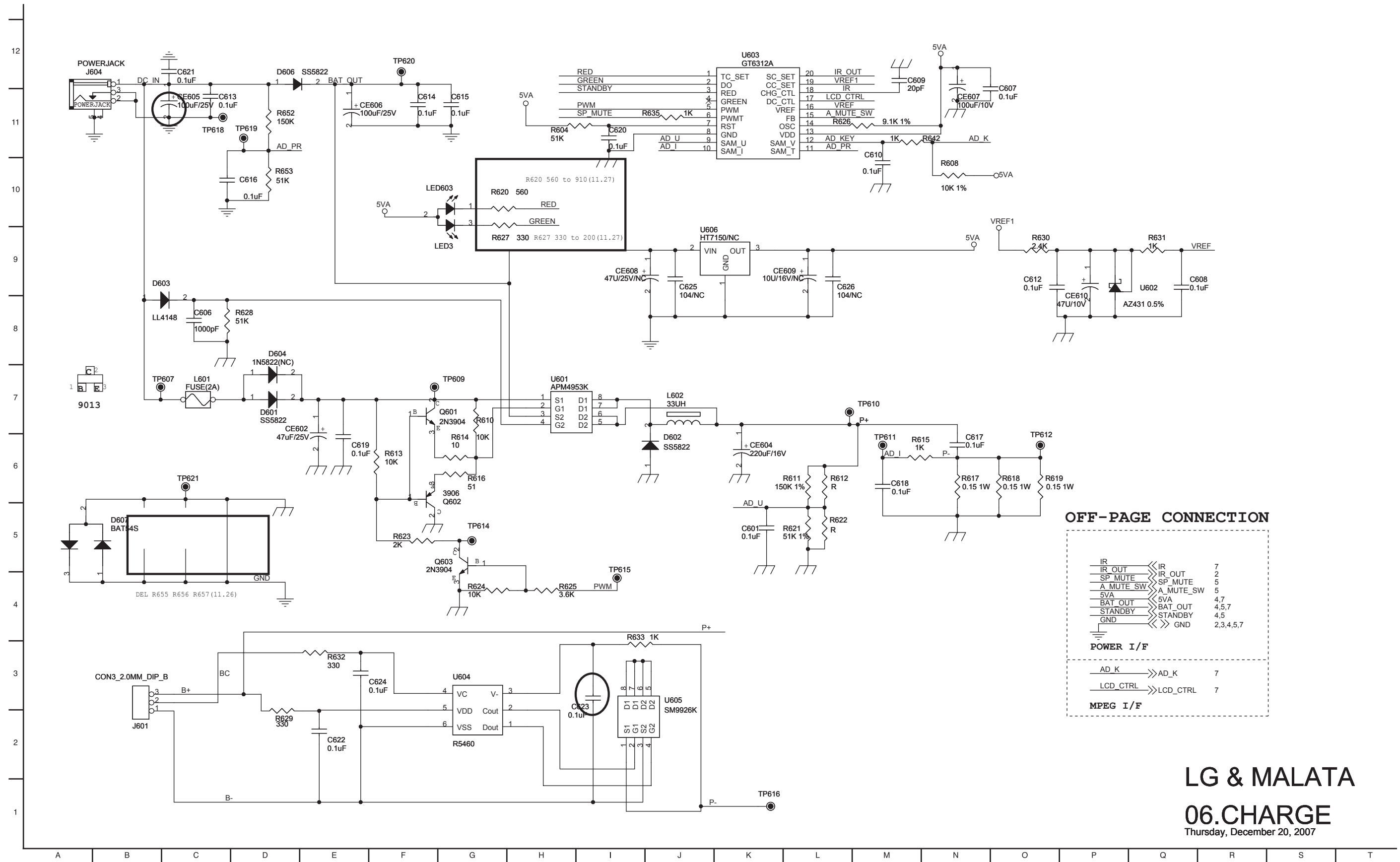

OFF-PAGE CONNECTION

IR	IR	7
IR_OUT	IR_OUT	2
SP_MUTE	SP_MUTE	5
A_MUTE_SW	A_MUTE_SW	5
5VA	5VA	5
BAT_OUT	5VA	4,7
STANDBY	BAT_OUT	4,5,7
GND	STANDBY	4,5
	GND	2,3,4,5,7

POWER I/F

AD_K	AD_K	7
LCD_CTRL	LCD_CTRL	7

MPEG I/F

LG & MALATA
06.CHARGE
 Thursday, December 20, 2007

6. LCD I/F CIRCUIT DIAGRAM

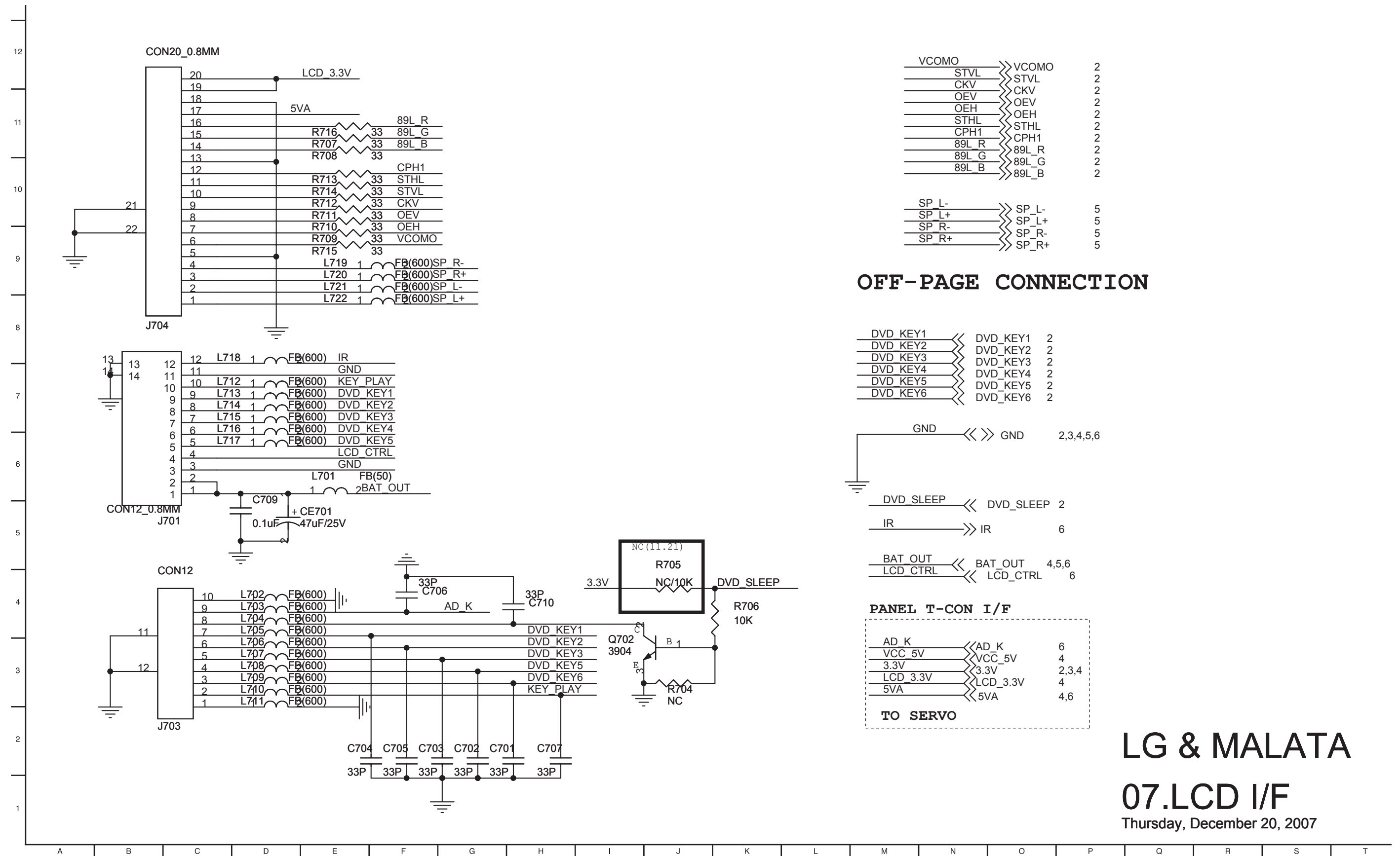

7. KEY MENU CIRCUIT DIAGRAM

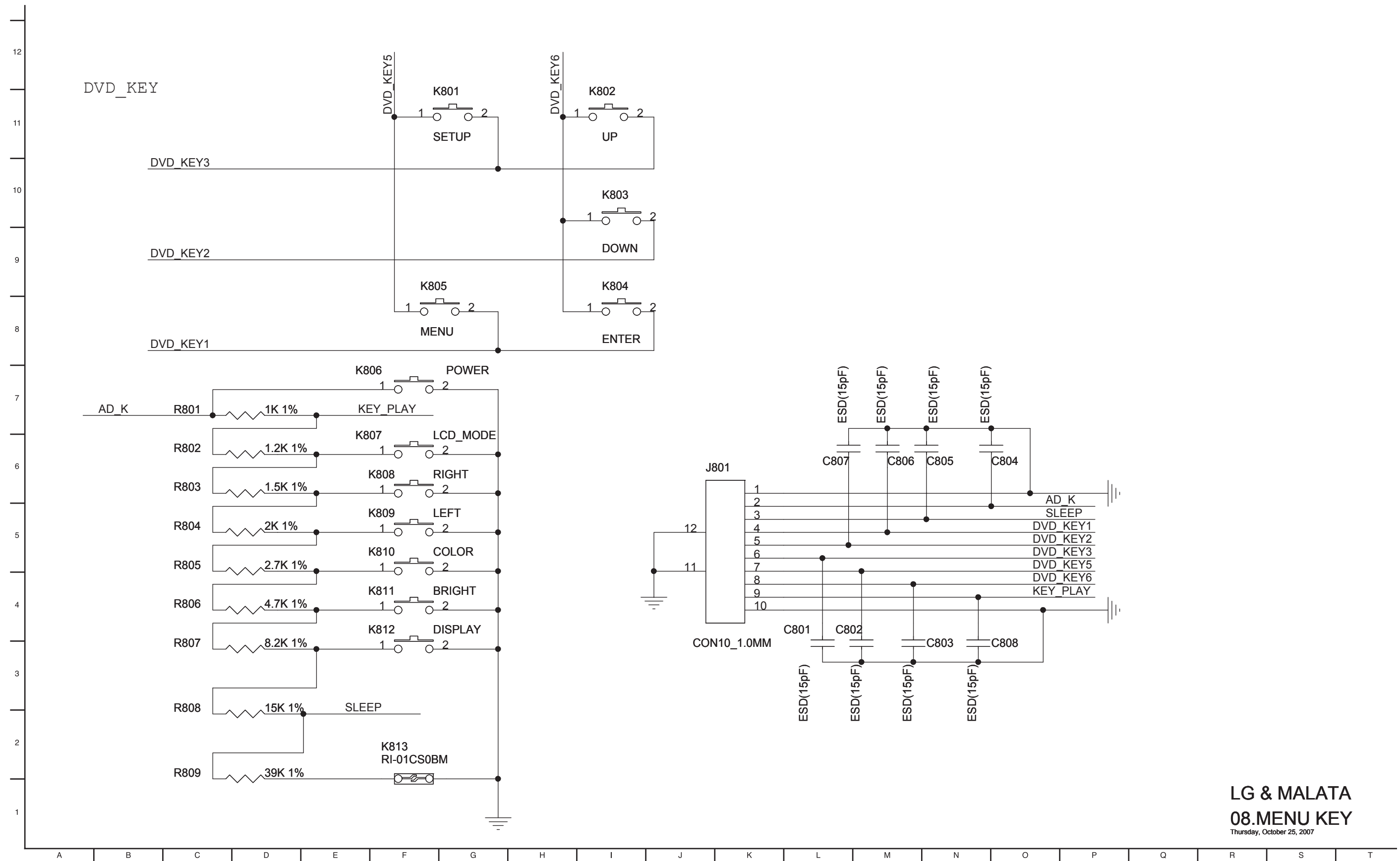

LG & MALATA
08.MENU KEY

Thursday, October 25, 2007

MODE PIN NO.	STOP	PLAY
Q515		
Emitter	5.06	4.96
Collector	0.5	0.48
Base	0	0
Q601		
Emitter	12.26	12.25
Collector	12.26	12.26
Base	12.26	12.25
Q602		
Emitter	12.26	12.25
Collector	0	0
Base	12.26	12.25
Q603		
Emitter	0	0
Collector	12.26	12.25
Base	0	0
Q702		
Emitter	0	0
Collector	0	0
Base	0	-1.92
Q1(5448)		
Emitter	5.59	5.58
Collector	0	0
Base	0	0
Q2(5448)		
Emitter	0	0
Collector	0	0
Base	0.70	0.70
Q1(5451)		
Emitter	0.63	0.63
Collector	5	5
Base	1.33	1.33
Q2(5451)		
Emitter	0.63	0.63
Collector	5	5
Base	1.32	1.32
Q3(5451)		
Emitter	0.62	0.62
Collector	5	5
Base	1.32	1.32
CE201		
+	3.33	3.33
-	0	0
CE202		
+	3.33	3.33
-	0	0
CE203		
+	3.33	3.33
-	0	0
CE204		
+	2.00	2.00
-	0	0
CE205		
+	3.33	3.33
-	0	0

MODE PIN NO.	STOP	PLAY
CE206		
+	1.41	1.40
-	0	0
CE207		
+	3.33	3.32
-	0	0
CE208		
+	1.87	1.87
-	0	0
CE209		
+	3.33	3.33
-	0	0
CE211		
+	3.33	3.32
-	0	0
CE212		
+	3.26	3.26
-	0	0
CE213		
+	3.33	3.33
-	0	0
CE301		
+	3.33	3.33
-	0	0
CE402		
+	5.07	4.98
-	0	0
CE403		
+	5.07	5.00
-	0	0
CE406		
+	5.06	5.00
-	0	0
CE410		
+	3.39	3.38
-	0	0
CE411		
+	11.80	11.71
-	0	0
CE412		
+	5.06	5.04
-	0	0
CE413		
+	11.80	11.71
-	0	0
CE415		
+	3.37	3.36
-	0	0
CE416		
+	5.15	4.99
-	0	0
CE417		
+	3.34	3.33
-	3.34	3.33
CE418		

MODE PIN NO.	STOP	PLAY
+	3.34	3.33
-	3.34	3.33
CE501		
+	2.45	2.40
-	0	0
CE502		
+	2.45	2.40
-	0	0
CE503		
+	5.54	5.51
-	0	0
CE504		
+	2.41	2.36
-	0	0
CE505		
+	5.54	5.50
-	0	0
CE506		
+	5.06	5.00
-	0	0
CE507		
+	11.78	11.71
-	0	0
CE508		
+	4.04	4.02
-	1.63	1.63
CE509		
+	4.05	4.04
-	1.63	1.63
CE510		
+	1.65	1.50
-	0	0
CE511		
+	5.55	5.50
-	0	0
CE512		
+	5.55	5.50
-	0	0
CE513		
+	2.43	2.39
-	0	0
CE514		
+	1.89	1.80
-	0	0
CE515		
+	2.43	2.40
-	0	0
CE516		
+	4.45	4.41
-	0	0
CE602		
+	12.13	12.08
-	0	0
CE604		
+	10.40	10.40

MODE PIN NO.	STOP	PLAY
-	0	0
CE605		
+	12.14	12.08
-	0	0
CE606		
+	11.80	11.71
-	0	0
CE607		
+	5.06	5.03
-	0	0
CE610		
+	2.50	2.50
-	0	0
CE701		
+	11.79	11.74
-	0	0

PRINTED CIRCUIT BOARD DIAGRAMS

1. MAIN P.C.BOARD (TOP VIEW)

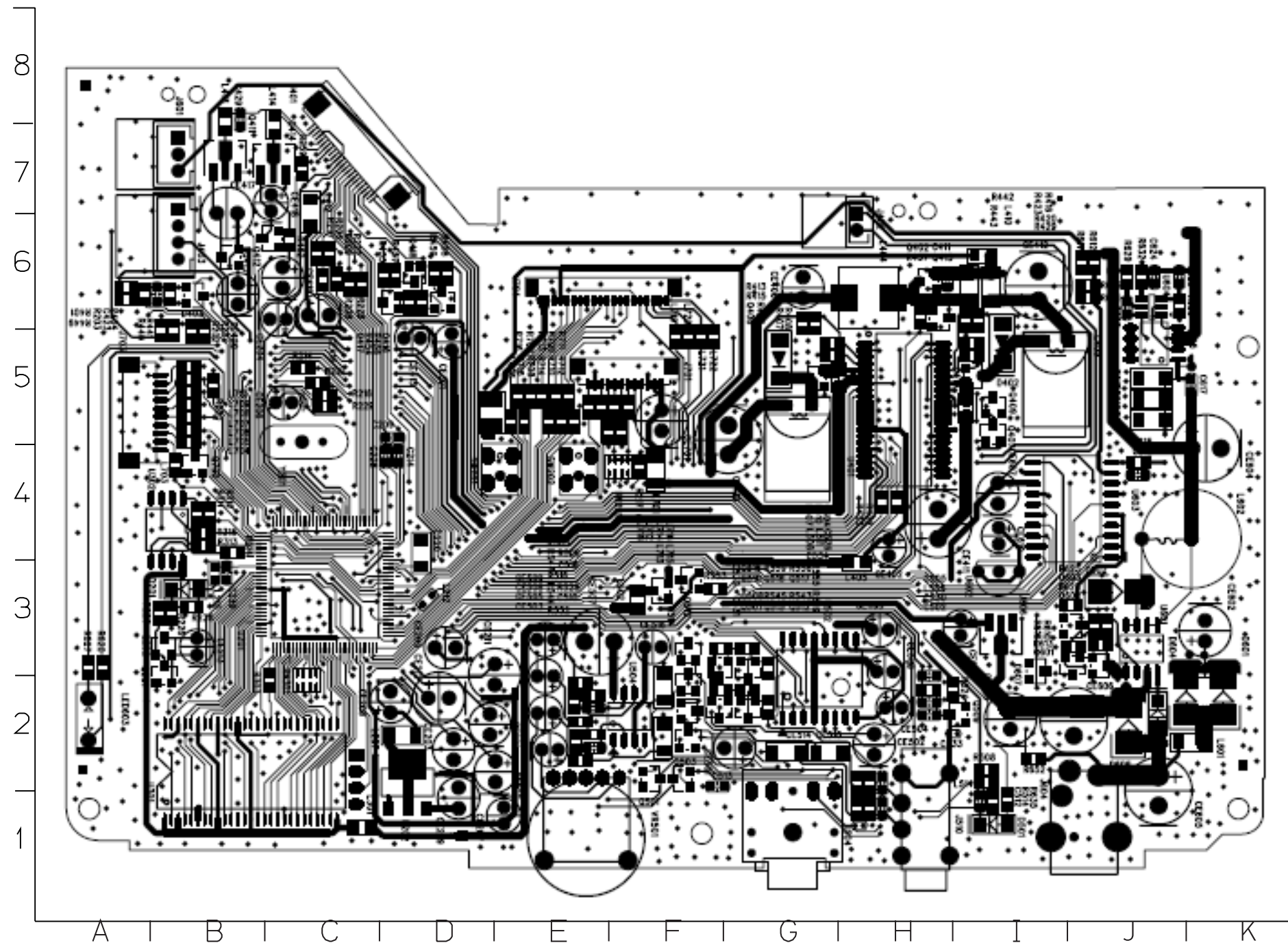

**MAIN P.C.BOARD
(BOTTOM VIEW)**

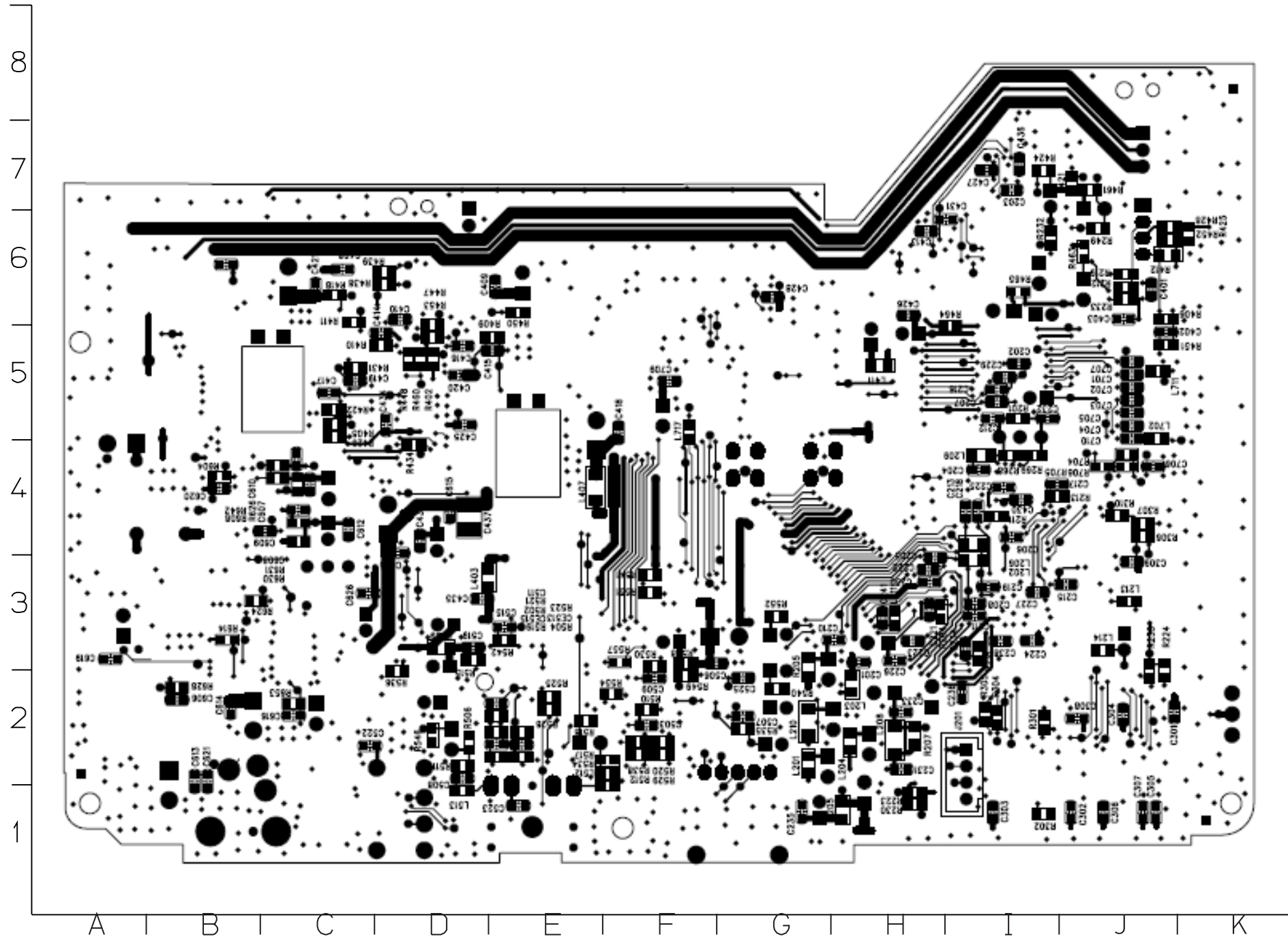

**2. KEY MENU P.C.BOARD
(TOP VIEW)**

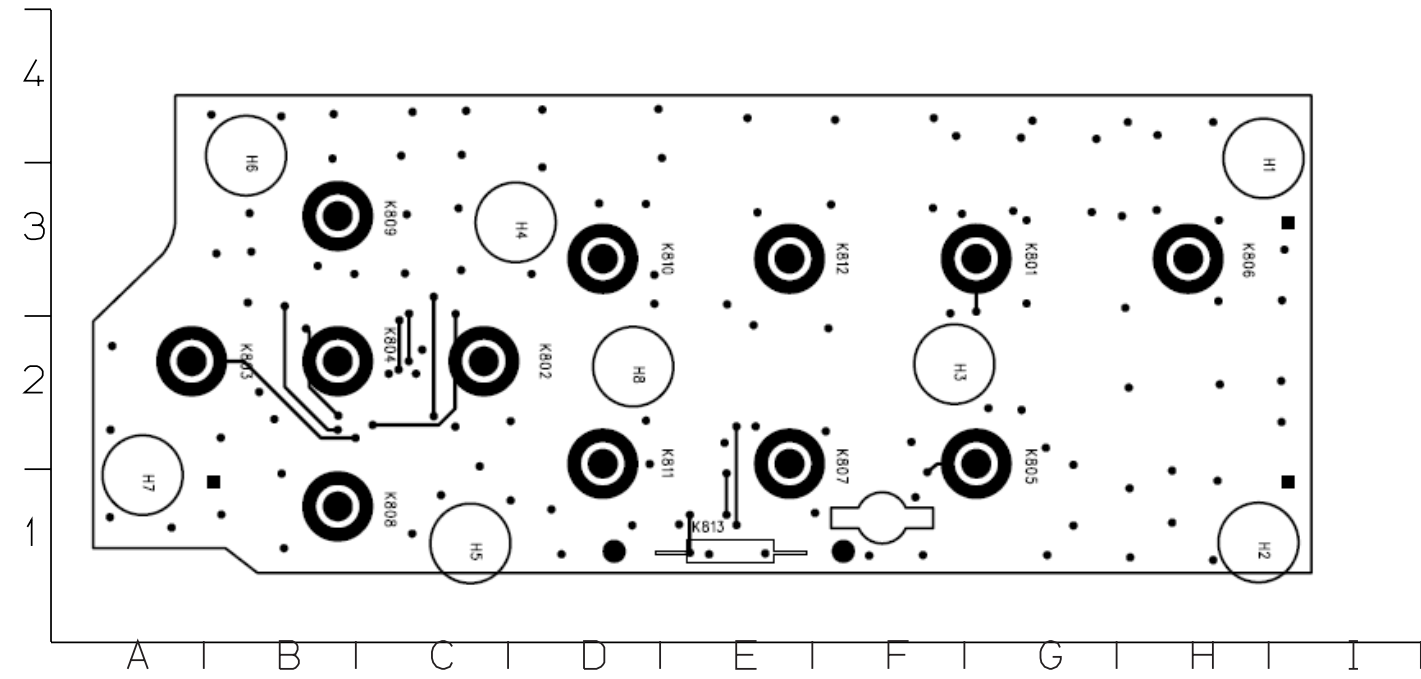

(BOTTOM VIEW)

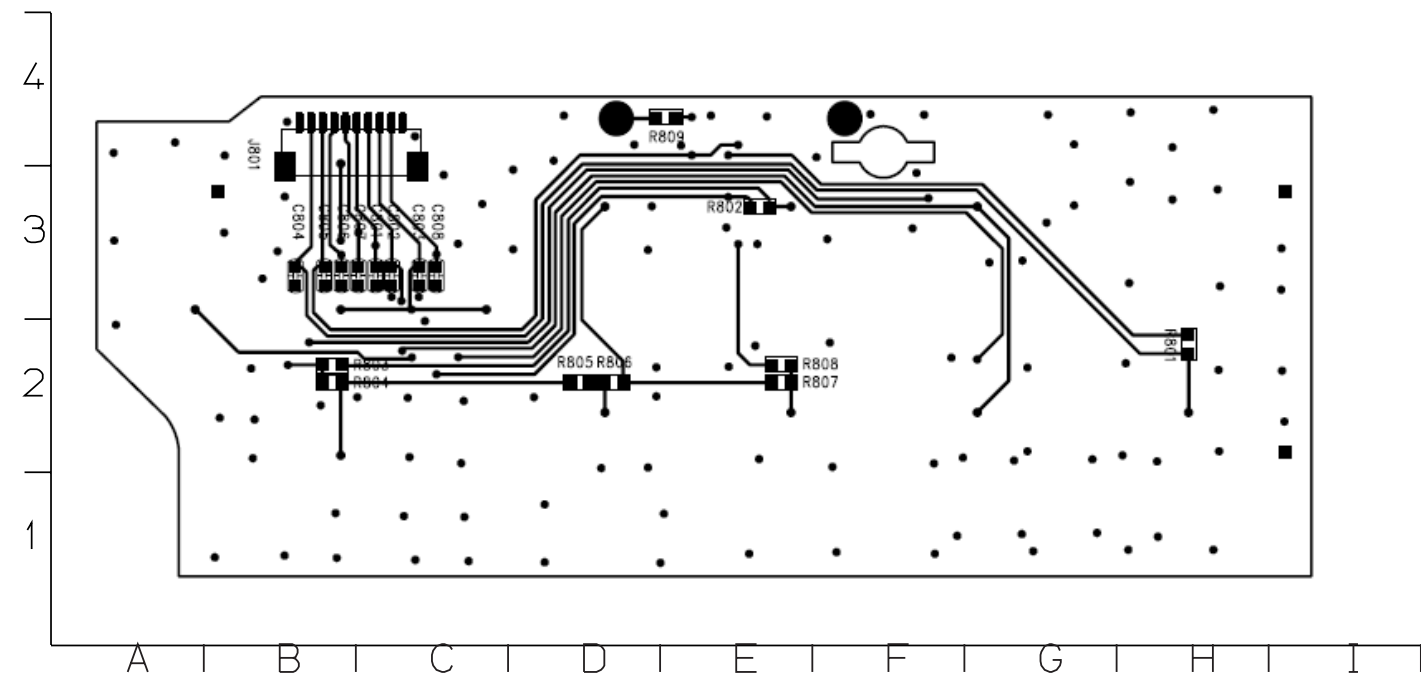

MEMO

Blank lined area for writing on page 3-63.

MEMO

Blank lined area for writing on page 3-64.