

CONTENTS

SECTION 1 SUMMARY

SECTION 2 EXPLODED VIEWS

SECTION 3 ELECTRICAL

SECTION 4 REPLACEMENT PARTS LIST

SECTION 1

SUMMARY

CONTENTS

PRODUCT SAFETY SERVICING GUIDELINES FOR VIDEO PRODUCTS	1-3
SERVICING PRECAUTIONS	1-4
SPECIFICATIONS	1-5

PRODUCT SAFETY SERVICING GUIDELINES FOR VIDEO PRODUCTS

CAUTION : DO NOT ATTEMPT TO MODIFY THIS PRODUCT IN ANY WAY, NEVER PERFORM CUSTOMIZED INSTALLATIONS WITHOUT MANUFACTURER'S APPROVAL. UNAUTHORIZED MODIFICATIONS WILL NOT ONLY VOID THE WARRANTY, BUT MAY LEAD TO YOUR BEING LIABLE FOR ANY RESULTING PROPERTY DAMAGE OR USER INJURY.

SERVICE WORK SHOULD BE PERFORMED ONLY AFTER YOU ARE THOROUGHLY FAMILIAR WITH ALL OF THE FOLLOWING SAFETY CHECKS AND SERVICING GUIDELINES. TO DO OTHERWISE, INCREASES THE RISK OF POTENTIAL HAZARDS AND INJURY TO THE USER.

WHILE SERVICING, USE AN ISOLATION TRANSFORMER FOR PROTECTION FROM A.C. LINE SHOCK.

SAFETY CHECKS

AFTER THE ORIGINAL SERVICE PROBLEM HAS BEEN CORRECTED, A CHECK SHOULD BE MADE OF THE FOLLOWING.

SUBJECT : FIRE & SHOCK HAZARD

1. BE SURE THAT ALL COMPONENTS ARE POSITIONED IN SUCH A WAY AS TO AVOID POSSIBILITY OF ADJACENT COMPONENT SHORTS. THIS IS ESPECIALLY IMPORTANT ON THOSE MODULES WHICH ARE TRANSPORTED TO AND FROM THE REPAIR SHOP.
2. NEVER RELEASE A REPAIR UNLESS ALL PROTECTIVE DEVICES SUCH AS INSULATORS, BARRIERS, COVERS, SHIELDS, STRAIN RELIEFS, POWER SUPPLY CORDS, AND OTHER HARDWARE HAVE BEEN REINSTALLED PER ORIGINAL DESIGN. BE SURE THAT THE SAFETY PURPOSE OF THE POLARIZED LINE PLUG HAS NOT BEEN DEFEATED.
3. SOLDERING MUST BE INSPECTED TO DISCOVER POSSIBLE COLD SOLDER JOINTS, SOLDER SPLASHES OR SHARP SOLDER POINTS. BE CERTAIN TO REMOVE ALL LOOSE FOREIGN PARTICLES.
4. CHECK FOR PHYSICAL EVIDENCE OF DAMAGE OR DETERIORATION TO PARTS AND COMPONENTS. FOR FRAYED LEADS, DAMAGED INSULATION (INCLUDING A.C. CORD), AND REPLACE IF NECESSARY FOLLOW ORIGINAL LAYOUT, LEAD LENGTH AND DRESS.
5. NO LEAD OR COMPONENT SHOULD TOUCH A RECEIVING TUBE OR A RESISTOR RATED AT 1 WATT OR MORE. LEAD TENSION AROUND PROTRUDING METAL SURFACES MUST BE AVOIDED.
6. ALL CRITICAL COMPONENTS SUCH AS FUSES, FLAMEPROOF RESISTORS, CAPACITORS, ETC. MUST BE REPLACED WITH EXACT FACTORY TYPES, DO NOT USE REPLACEMENT COMPONENTS OTHER THAN THOSE SPECIFIED OR MAKE UNRECOMMENDED CIRCUIT MODIFICATIONS.
7. AFTER RE-ASSEMBLY OF THE SET ALWAYS PERFORM AN A.C. LEAKAGE TEST ON ALL EXPOSED METALLIC PARTS OF THE CABINET, (THE CHANNEL SELECTOR KNOB, ANTENNA TERMINALS, HANDLE AND SCREWS) TO BE SURE THE SET IS SAFE TO OPERATE WITHOUT DANGER OF ELECTRICAL SHOCK. DO NOT USE A LINE ISOLATION TRANSFORMER DURING THIS TEST USE AN A.C. VOLT-METER, HAVING 5000 OHMS PER VOLT OR MORE SENSITIVITY, IN THE FOLLOWING MANNER; CONNECT A 1500 OHM 10 WATT RESISTOR, PARALLELED BY A .15 MFD. 150.V A.C TYPE CAPACITOR BETWEEN A KNOWN GOOD EARTH GROUND (WATER PIPE, CONDUIT, ETC.) AND THE EXPOSED METALLIC PARTS, ONE AT A TIME. MEASURE THE A.C. VOLTAGE ACROSS THE COMBINATION OF 1500 OHM RESISTOR AND .15 MFD CAPACITOR. REVERSE THE A.C. PLUG AND REPEAT A.C. VOLTAGE MEASUREMENTS FOR EACH EXPOSED METALLIC PART. VOLTAGE MEASURED MUST NOT EXCEED 75 VOLTS R.M.S. THIS CORRESPONDS TO 0.5 MILLIAMPS A.C ANY VALUE EXCEEDING THIS LIMIT CONSTITUTES A POTENTIAL SHOCK HAZARD AND MUST BE CORRECTED IMMEDIATELY.

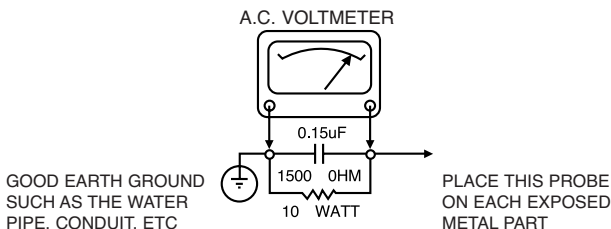

SUBJECT: GRAPHIC SYMBOLS



THE LIGHTNING FLASH WITH ARROWHEAD SYMBOL, WITHIN AN EQUILATERAL TRIANGLE, IS INTENDED TO ALERT THE SERVICE PERSONNEL TO THE PRESENCE OF UNINSULATED "DANGEROUS VOLTAGE" THAT MAY BE OF SUFFICIENT MAGNITUDE TO CONSTITUTE A RISK OF ELECTRIC SHOCK.



THE EXCLAMATION POINT WITHIN AN EQUILATERAL TRIANGLE IS INTENDED TO ALERT THE SERVICE PERSONNEL TO THE PRESENCE OF IMPORTANT SAFETY INFORMATION IN SERVICE LITERATURE.

SUBJECT : X-RADIATION

1. BE SURE PROCEDURES AND INSTRUCTIONS TO ALL SERVICE PERSONNEL COVER THE SUBJECT OF X-RADIATION. THE ONLY POTENTIAL SOURCE OF X-RAYS IN CURRENT T.V. RECEIVERS IS THE PICTURE TUBE. HOWEVER, THIS TUBE DOES NOT EMIT X-RAYS WHEN THE HIGH VOLTAGE IS AT THE FACTORY SPECIFIED LEVEL. THE PROPER VALUE IS GIVEN IN THE APPLICABLE SCHEMATIC. OPERATION AT HIGHER VOLTAGES MAY CAUSE A FAILURE OF THE PICTURE TUBE OR HIGH VOLTAGE SUPPLY AND, UNDER CERTAIN CIRCUMSTANCES, MAY PRODUCE RADIATION IN EXCESS OF DESIRABLE LEVELS.
2. ONLY FACTORY SPECIFIED C.R.T. ANODE CONNECTORS MUST BE USED. DEGAUSSING SHIELDS ALSO SERVE AS X-RAY SHIELD IN COLOR SETS, ALWAYS RE-INSTALL THEM.
3. IT IS ESSENTIAL THAT SERVICE PERSONNEL HAVE AVAILABLE AN ACCURATE AND RELIABLE HIGH VOLTAGE METER. THE CALIBRATION OF THE METER SHOULD BE CHECKED PERIODICALLY AGAINST A REFERENCE STANDARD, SUCH AS THE ONE AVAILABLE AT YOUR DISTRIBUTOR.
4. WHEN THE HIGH VOLTAGE CIRCUITRY IS OPERATING PROPERLY THERE IS NO POSSIBILITY OF AN X-RADIATION PROBLEM. EVERY TIME A COLOR CHASSIS IS SERVICED, THE BRIGHTNESS SHOULD BE RUN UP AND DOWN WHILE MONITORING THE HIGH VOLTAGE WITH A METER TO BE CERTAIN THAT THE HIGH VOLTAGE DOES NOT EXCEED THE SPECIFIED VALUE AND THAT IT IS REGULATING CORRECTLY. WE SUGGEST THAT YOU AND YOUR SERVICE ORGANIZATION REVIEW TEST PROCEDURES SO THAT VOLTAGE REGULATION IS ALWAYS CHECKED AS A STANDARD SERVICING PROCEDURE. AND THAT THE HIGH VOLTAGE READING BE RECORDED ON EACH CUSTOMER'S INVOICE.
5. WHEN TROUBLESHOOTING AND MAKING TEST MEASUREMENTS IN A PRODUCT WITH A PROBLEM OF EXCESSIVE HIGH VOLTAGE, AVOID BEING UNNECESSARILY CLOSE TO THE PICTURE TUBE AND THE HIGH VOLTAGE SUPPLY. DO NOT OPERATE THE PRODUCT LONGER THAN IS NECESSARY TO LOCATE THE CAUSE OF EXCESSIVE VOLTAGE.
6. REFER TO HV. B+ AND SHUTDOWN ADJUSTMENT PROCEDURES DESCRIBED IN THE APPROPRIATE SCHEMATIC AND DIAGRAMS (WHERE USED).

SUBJECT: IMPLOSION

1. ALL DIRECT VIEWED PICTURE TUBES ARE EQUIPPED WITH AN INTEGRAL IMPLOSION PROTECTION SYSTEM, BUT CARE SHOULD BE TAKEN TO AVOID DAMAGE DURING INSTALLATION, AVOID SCRATCHING THE TUBE. IF SCRATCHED REPLACE IT.
2. USE ONLY RECOMMENDED FACTORY REPLACEMENT TUBES.

SUBJECT : TIPS ON PROPER INSTALLATION

1. NEVER INSTALL ANY PRODUCT IN A CLOSED-IN RECESS, CUBBY-HOLE OR CLOSELY FITTING SHELF SPACE. OVER OR CLOSE TO HEAT DUCT, OR IN THE PATH OF HEATED AIR FLOW.
2. AVOID CONDITIONS OF HIGH HUMIDITY SUCH AS: OUTDOOR PATIO INSTALLATIONS WHERE DEW IS A FACTOR, NEAR STEAM RADIATORS WHERE STEAM LEAKAGE IS A FACTOR, ETC.
3. AVOID PALCEMENT WHERE DRAPERIES MAY OBSTRUCT REAR VENTING. THE CUSTOMER SHOULD ALSO AVOID THE USE OF DECORATIVE SCARVES OR OTHER COVERINGS WHICH MIGHT OBSTRUCT VENTILATION.
4. WALL AND SHELF MOUNTED INSTALLATIONS USING A COMMERCIAL MOUNTING KIT. MUST FOLLOW THE FACTORY APPROVED MOUNTING INSTRUCTIONS A PRODUCT MOUNTED TO A SHELF OR PLATFORM MUST RETAIN ITS ORIGINAL FEET (OR THE EQUIVALENT THICKNESS IN SPACERS) TO PROVIDE ADEQUATE AIR FLOW ACROSS THE BOTTOM, BOLTS OR SCREWS USED FOR FASTENERS MUST NOT TOUCH ANY PARTS OR WIRING. PERFORM LEAKAGE TEST ON CUSTOMIZED INSTALLATIONS.
5. CAUTION CUSTOMERS AGAINST THE MOUNTING OF A PRODUCT ON SLOPING SHELF OR A TILTED POSITION, UNLESS THE PRODUCT IS PROPERLY SECURED.
6. A PRODUCT ON A ROLL-ABOUT CART SHOULD BE STABLE ON ITS MOUNTING TO THE CART. CAUTION THE CUSTOMER ON THE HAZARDS OF TRYING TO ROLL A CART WITH SMALL CASTERS ACROSS THRESHOLDS OR DEEP PILE CARPETS.
7. CAUTION CUSTOMERS AGAINST THE USE OF A CART OR STAND WHICH HAS NOT BEEN LISTED BY UNDERWRITERS LABORATORIES, INC. FOR USE WITH THEIR SPECIFIC MODEL OF TELEVISION RECEIVER OR GENERALLY APPROVED FOR USE WITH T.V.'S OF THE SAME OR LARGER SCREEN SIZE.
8. CAUTION CUSTOMERS AGAINST THE USE OF EXTENSION CORDS, EXPLAIN THAT A FOREST OF EXTENSIONS SPROUTING FROM A SINGLE OUTLET CAN LEAD TO DISASTROUS CONSEQUENCES TO HOME AND FAMILY.

SERVICING PRECAUTIONS

CAUTION : Before servicing the PORTABLE DVD covered by this service data and its supplements and addends, read and follow the SAFETY PRECAUTIONS. **NOTE** : if unforeseen circumstances create conflict between the following servicing precautions and any of the safety precautions in this publications, always follow the safety precautions.

Remembers Safety First:

General Servicing Precautions

1. Always unplug the PORTABLE DVD AC power cord from the AC power source before:
 - (1) Removing or reinstalling any component, circuit board, module, or any other assembly.
 - (2) Disconnection or reconnecting any internal electrical plug or other electrical connection.
 - (3) Connecting a test substitute in parallel with an electrolytic capacitor.
Caution : A wrong part substitution or incorrect polarity installation of electrolytic capacitors may result in an explosion hazard.
2. Do not spray chemicals on or near this PORTABLE DVD or any of its assemblies.
3. Unless specified otherwise in this service data, clean electrical contacts by applying an appropriate contact cleaning solution to the contacts with a pipe cleaner, cotton-tipped swab, or comparable soft applicator. Unless specified otherwise in this service data, lubrication of contacts is not required.
4. Do not defeat any plug/socket B+ voltage interlocks with which instruments covered by this service manual might be equipped.
5. Do not apply AC power to this PORTABLE DVD and/or any of its electrical assemblies unless all solid-state device heat sinks are correctly installed.
6. Always connect test instrument ground lead to the appropriate ground before connection the test instrument positive lead. Always remove the test instrument ground lead last.

Insulation Checking Procedure

Disconnect the attachment plug from the AC outlet and turn the power on. Connect an insulation resistance meter(500V) to the blades of the attachment plug. The insulation resistance between each blade of the attachment plug and accessible conductive parts (Note 1) should be more than 1M-ohm.

Note 1 : Accessible Conductive Parts including Metal panels, Input terminals, Earphone jacks, etc.

Electrostatically Sensitive (ES) Devices

Some semiconductor (solid state) devices can be damaged easily by static electricity. Such components commonly are called Electrostatically Sensitive (ES) Devices. Examples of typical ES devices are integrated circuits and some field effect transistors and semiconductor chip components.

The following techniques should be used to help reduce the incidence of component damage caused by static electricity.

1. Immediately before handling any semiconductor component or semiconductor-equipped assembly, drain off any electrostatic charge on your body by touching a known earth ground. Alternatively, obtain and wear a commercially available discharging wrist strap device, which should be removed for potential shock reasons prior to applying power to the unit under test.
2. After removing an electrical assembly equipped with ES devices, place the assembly on a conductive surface such as aluminum foil, to prevent electrostatic charge buildup or exposure of the assembly.
3. Use only a grounded-tip soldering iron to solder or unsolder ES devices.
4. Use only an anti-static solder removal device. Some solder removal devices not classified a "anti-static" can generate electrical charges sufficient to damage ES devices.
5. Do not use freon-propelled chemicals. These can generate electrical charge sufficient to damage ES devices.
6. Do not remove a replacement ES device from its protective package until immediately before you are ready to install it. (Most replacement ES devices are packaged with leads electrically shorted together by conductive foam, aluminum foil, or comparable conductive material).
7. Immediately before removing the protective material from the leads of a replacement ES device, touch the protective material to the chassis or circuit assembly into which the device will be installed.

Caution : Be sure no power is applied to the chassis or circuit, and observe all other safety precautions.

8. Minimize bodily motions when handling unpackaged replacement ES devices. (Normally harmless motion such as the brushing together of your clothes fabric or the lifting of your foot from a carpeted floor can generate static electricity sufficient to damage an ES device.)

SPECIFICATIONS

[DVD player]

Power supply	DC 9.8 V (AC adapter terminal), DC 7.4 V (Battery)
Power consumption	25 W with battery
Weight	12.6 lbs (0.66 kg) (without battery pack)
External dimensions (W X D X H)	7.3 x 5.9 x 1.0 inches (186 x 150 x 25 mm)
Signal system	PAL
Laser	Semiconductor laser, wavelength 650 nm (DVD), 780 nm (CD)
Frequency range (audio)	DVD linear sound: 48kHz sampling 4 Hz to 20 kHz 96kHz sampling 4 Hz to 44 kHz
Signal-to-noise ratio (audio)	More than 95 dB
Dynamic range (audio)	More than 95 dB
Harmonic distortion (audio)	0.08 %
Operating conditions	Temperature: 41°F to 95°F, Operation status: Horizontal

[Connectors]

Video input/output (VIDEO In/Out)	1.0 V (p-p), 75 Ω, negative sync., ø3.5mm mini jack x 1
Audio output (optical audio)	Optical connector (ø3.5mm) x 1
Audio input/output (AUDIO In/Out, analog audio)	2.0 Vrms(1 KHz, 0 dB), ø3.5mm mini jack x 1
Earphone terminal	ø3.5mm stereo mini jack x 1

[Liquid Crystal Display]

Panel size	7 inches (16:9)
Projection system	TN color transmission
Driving system	TFT active matrix
Resolution	800 x 480 (effective pixel rate: more than 99.99%)

[Supplied Accessories]

- RCA Audio/Video cable1
- AC Adapter (AD-DP40)1
- Power Cord1
- Battery Pack (DP-BT50)1
- Remote control1
- Battery for Remote control (Lithium)1

SECTION 2
EXPLODED VIEWS
CONTENTS

EXPLODED VIEWS	2-2
Cabinet and Main Frame Section	2-2
Deck Mechanism Section	2-3
Packing Accessory Section	2-4

EXPLODED VIEWS

• Cabinet and Main Frame Section

5

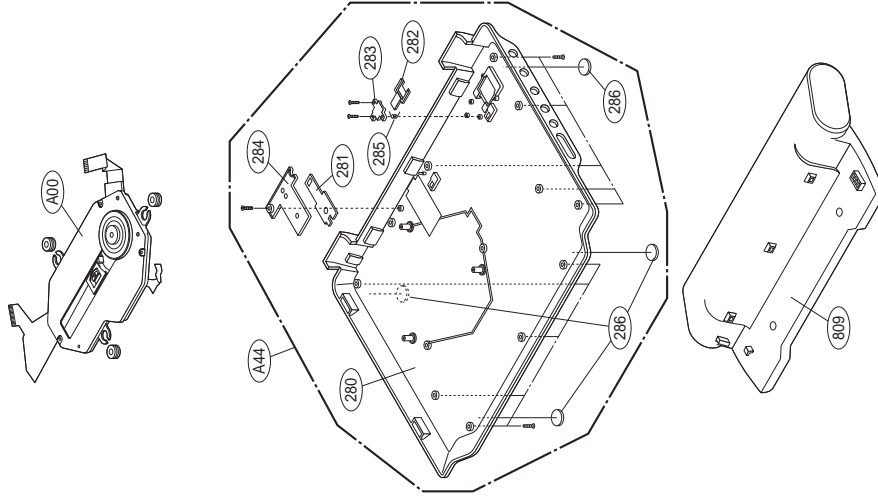

4

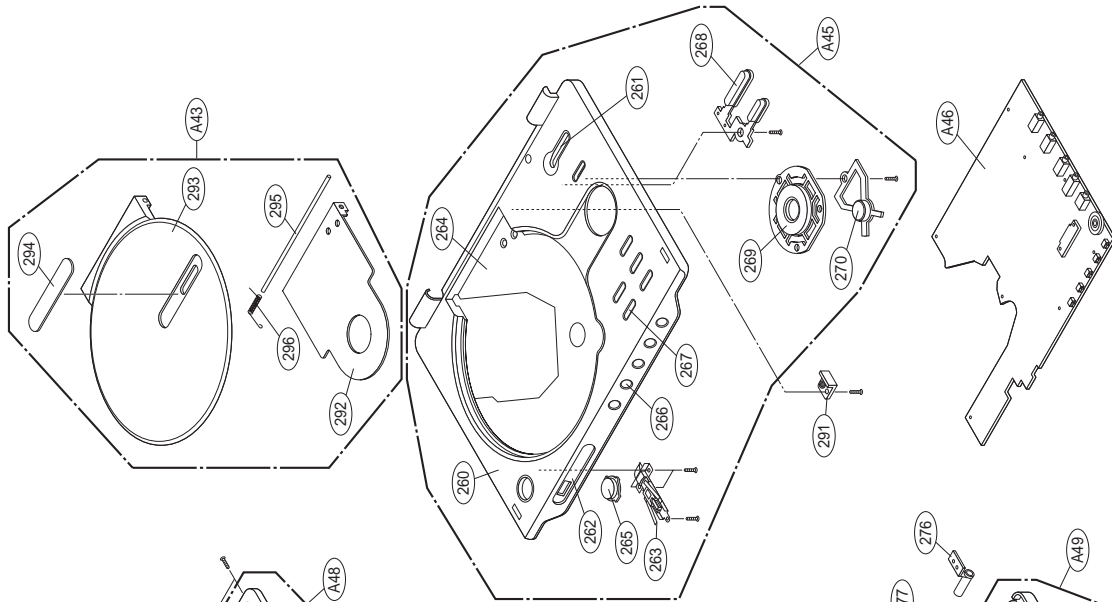

3

2

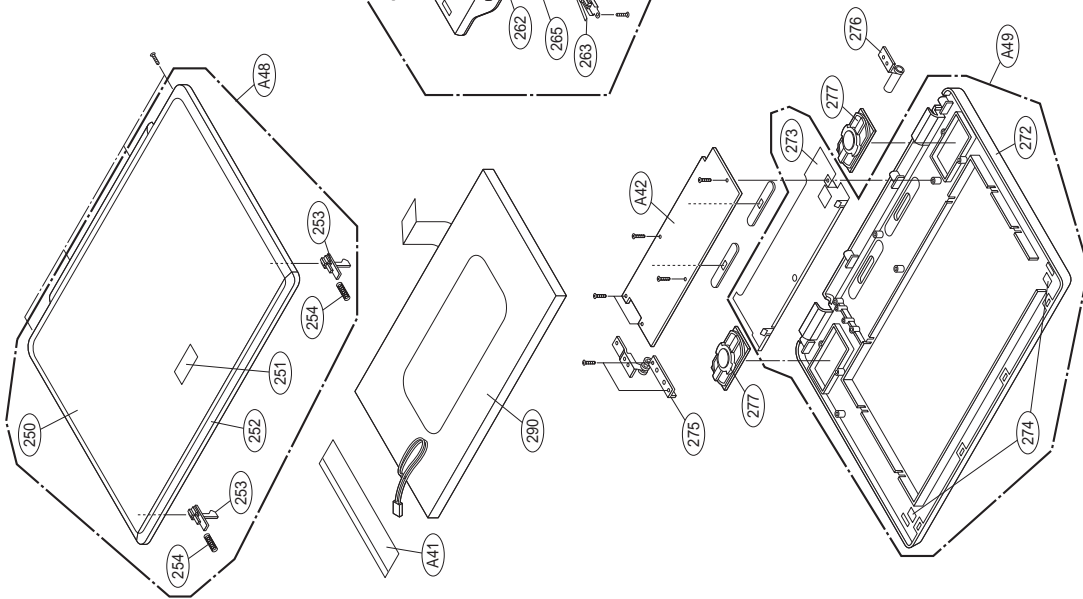

1

A

B

C

D

• Deck Mechanism Section

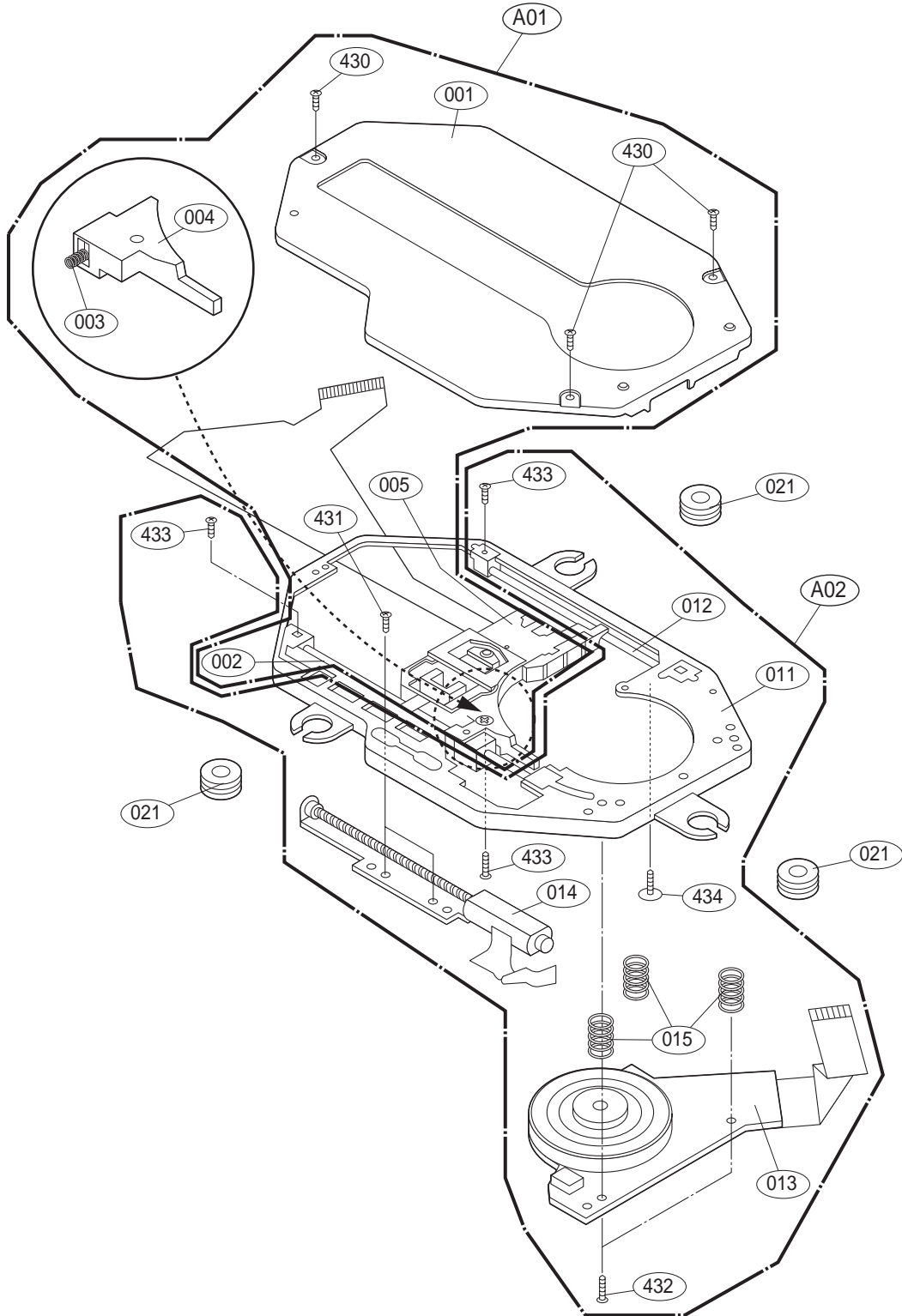

• Packing Accessory Section

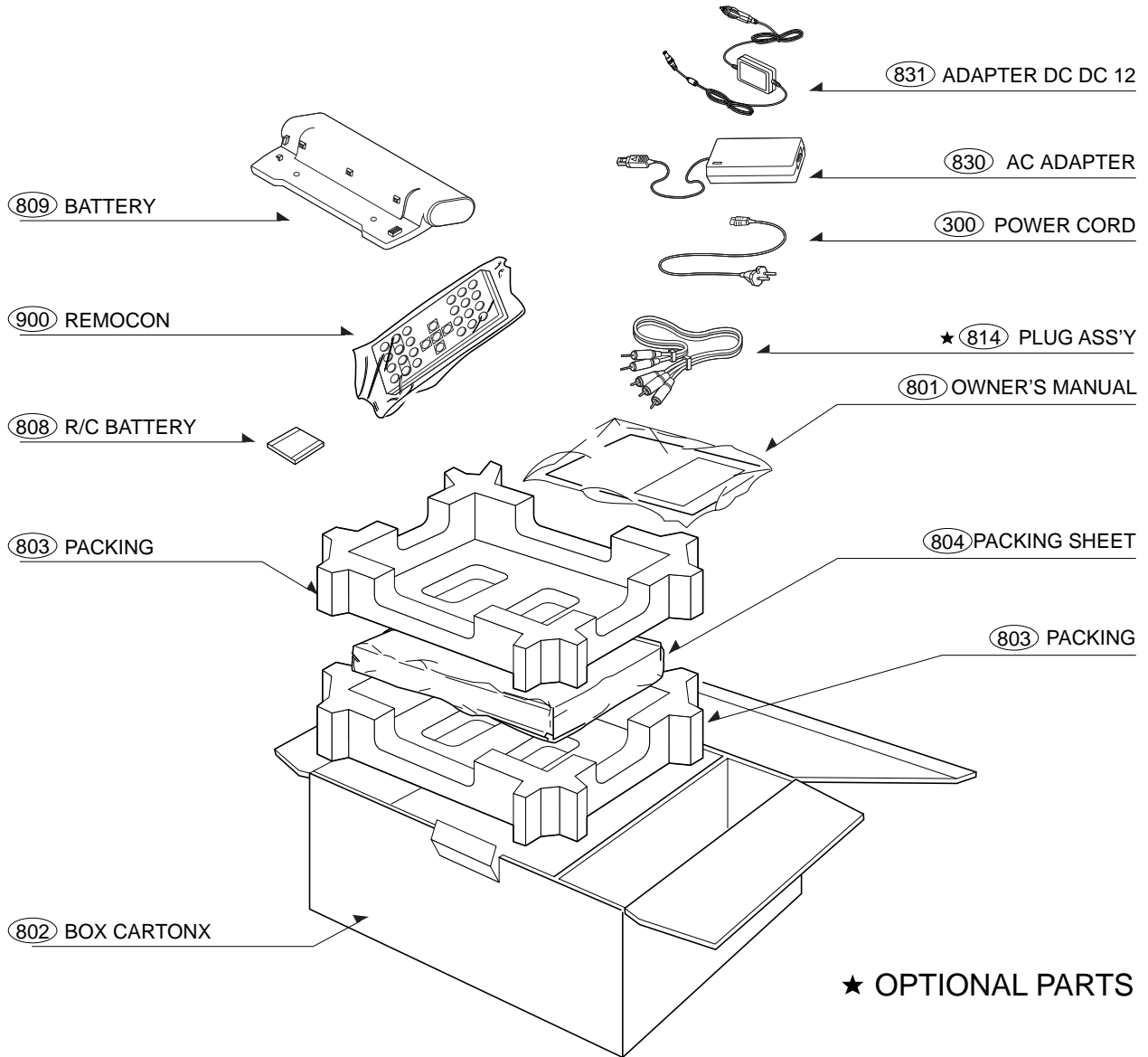

SECTION 3
ELECTRICAL
CONTENTS

LCD PART3-2
ELECTRICAL TROUBLE SHOOTING GUIDE3-16
BLCOK DIAGRAMS3-25
CIRCUIT DIAGRAM3-28
PRINTED CIRCUIT DIAGRAMS3-58

LCD PART

1) Power measuring

Measure each power after power supply.

CE809(+): -10V, CE812(+): +15V, C828: +7.5V, CE8F6: +5V, CE8H1: +9.8V

2) VCO frequency adjustment

Change the VR805 when there is no signal (video signal off) and adjust to 29.1MHz(error: +/- 0.03MHz) with a frequency counter.

Check the LCD operates at 29.68MHz when applying video signal with a frequency counter.

3) VCOM waveform adjustment

Adjust the VCOM level while changing the VR801 as below waveform by using the scope in the CE814.

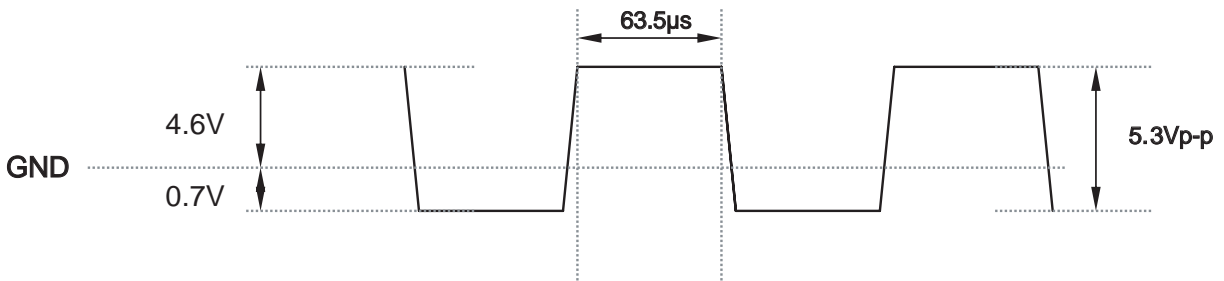

4) Adjustment of screen center position

Change and adjust the VR802 so that the middle vertical line between Green and magenta is located at the center of the LCD Panel on the Full color bar screen.



Full color bar screen

5) Removal of horizontal line noise

Remove a thick horizontal line noise while changing the VR803 and monitoring the logo screen.

Remove a thin horizontal line noise while viewing the logo screen after removing a thick horizontal line noise via the VR803.

LCD TROUBLE SHOOTING GUIDE(1/2)

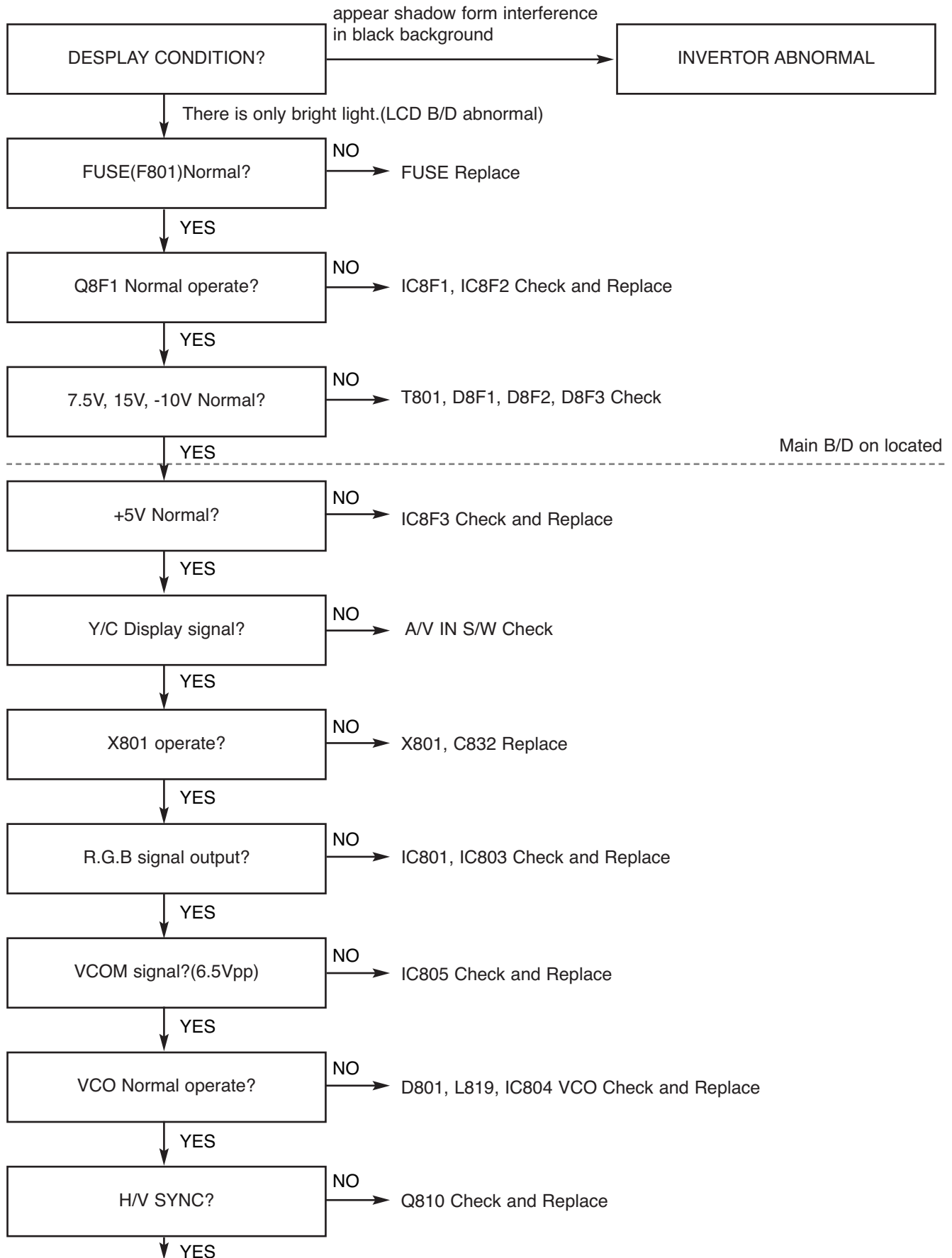

LCD TROUBLE SHOOTING GUIDE(2/2)

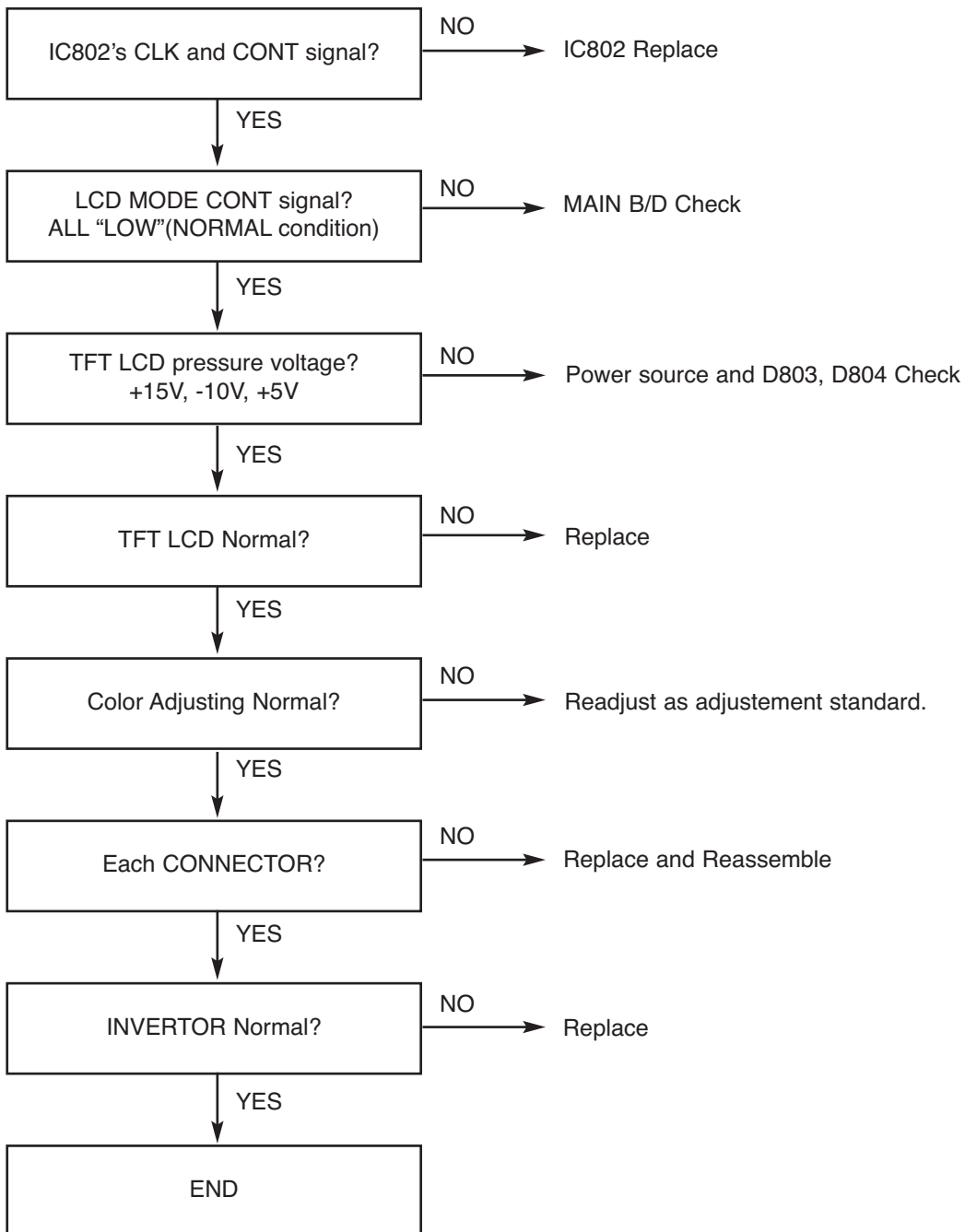

LCD BLOCK DIAGRAM

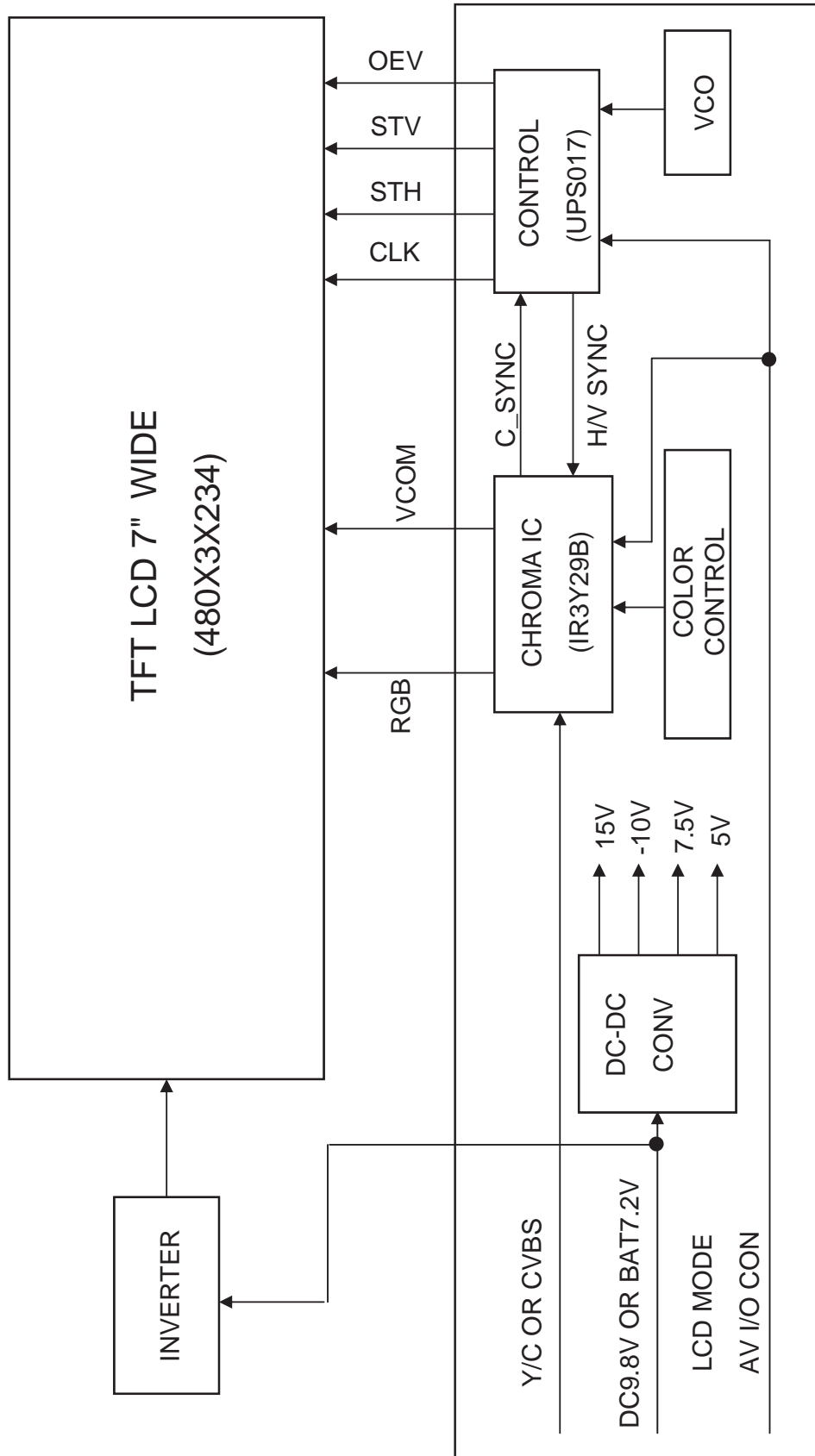

ELECTRICAL TROUBLE SHOOTING GUIDE

1. Power (DC-DC Converter) Circuit

A.

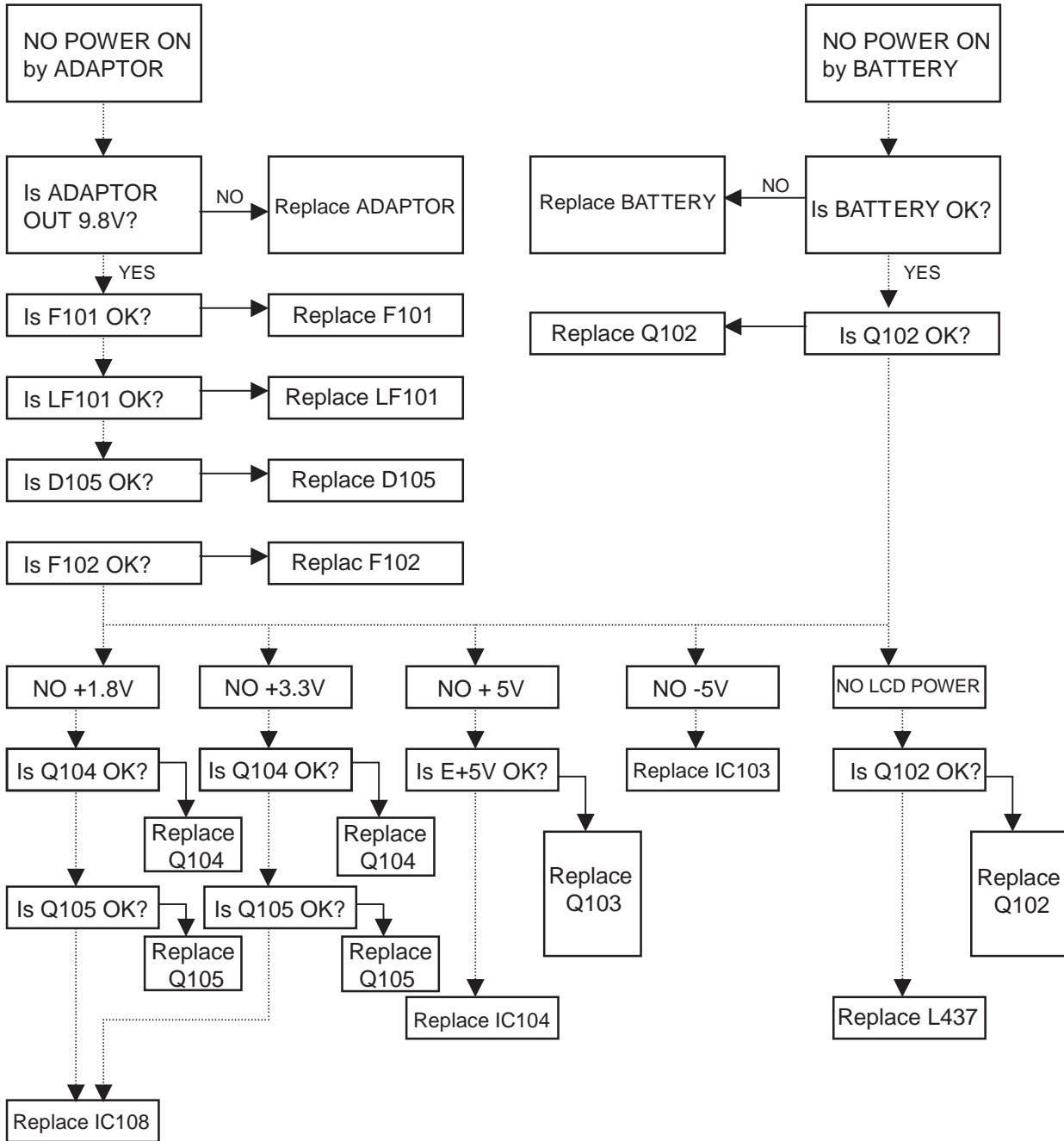

B. Audio Out abnormal

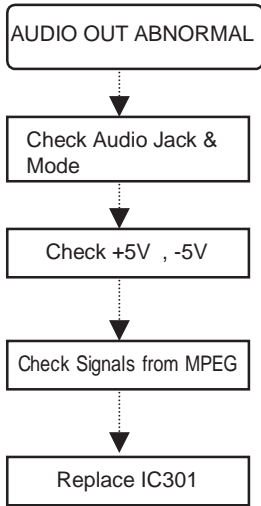

C. Video Out abnormal

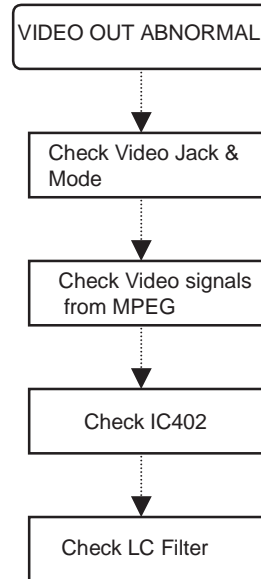

D. Audio In/Speaker abnormal

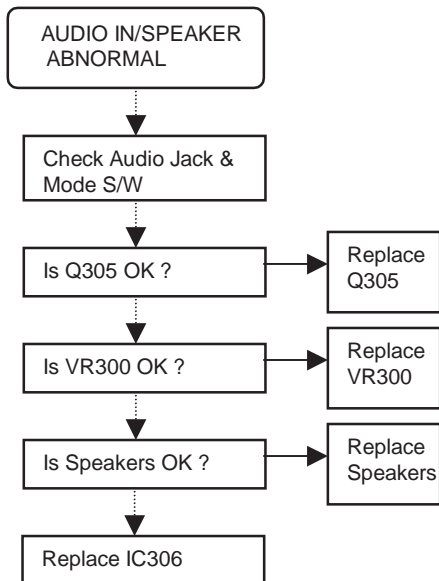

E. Video In abnormal

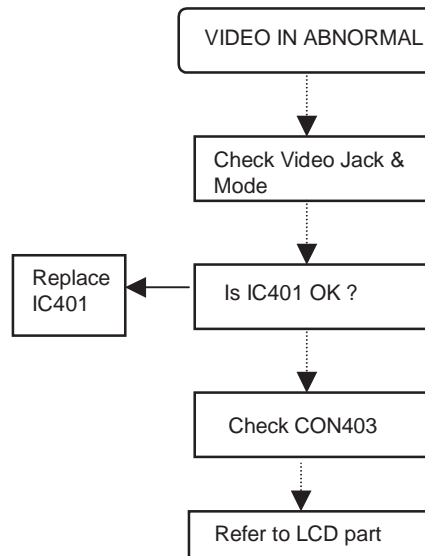

F. Picture abnormal

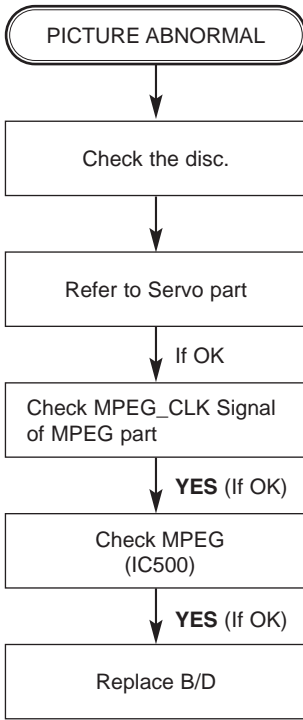

G. Disc Error

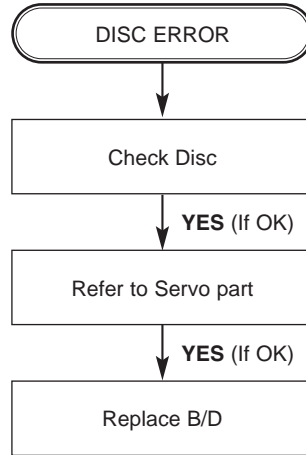

H. Open/Close abnormal

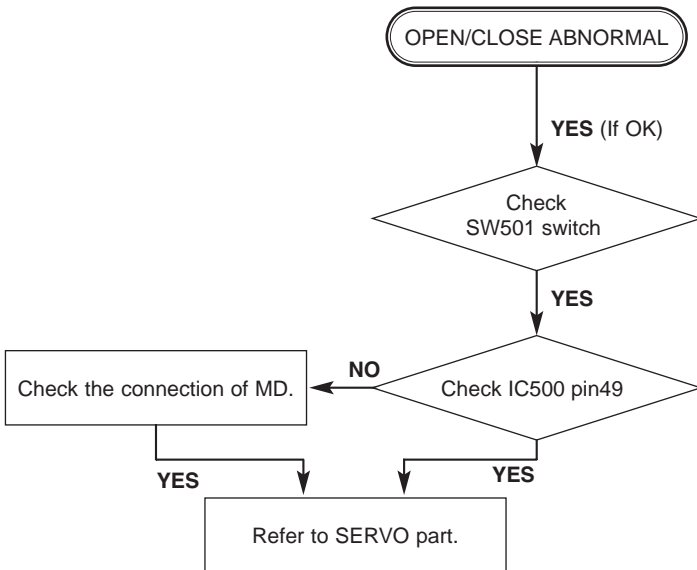

2. MPEG Circuit

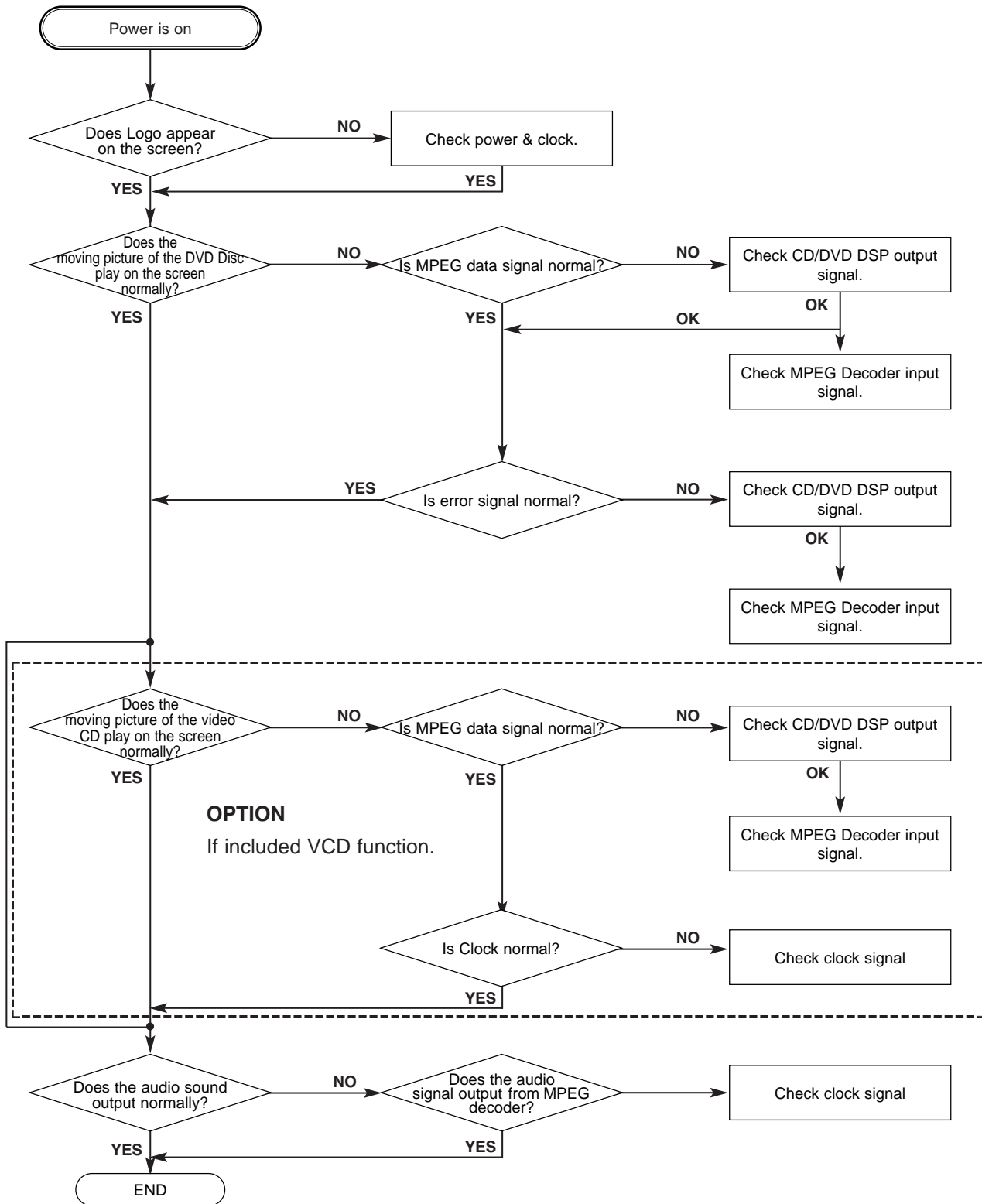

3. Front Circuit(Dogotrpm & Key)

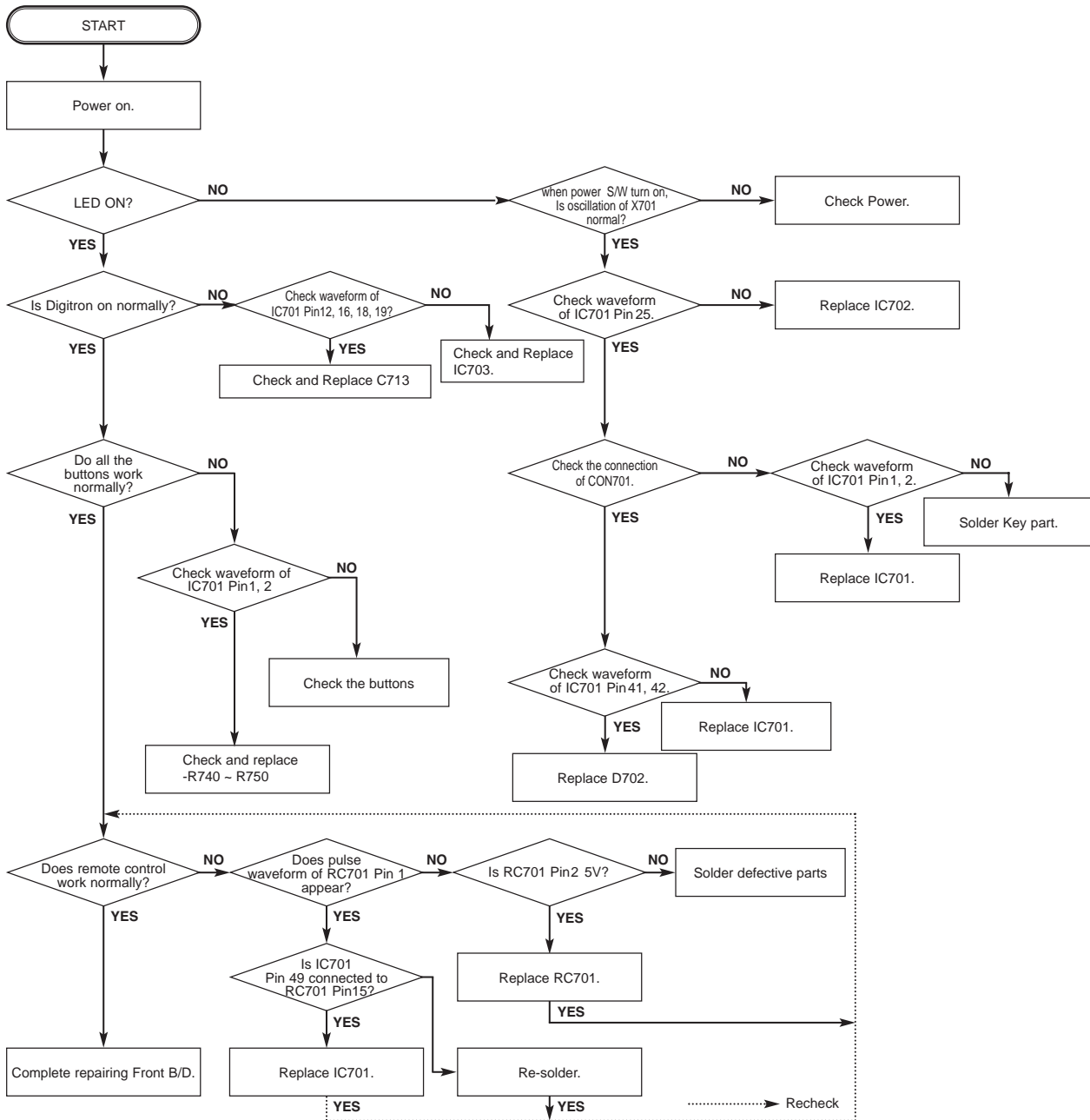

4. RF/Servo Circuit

A.

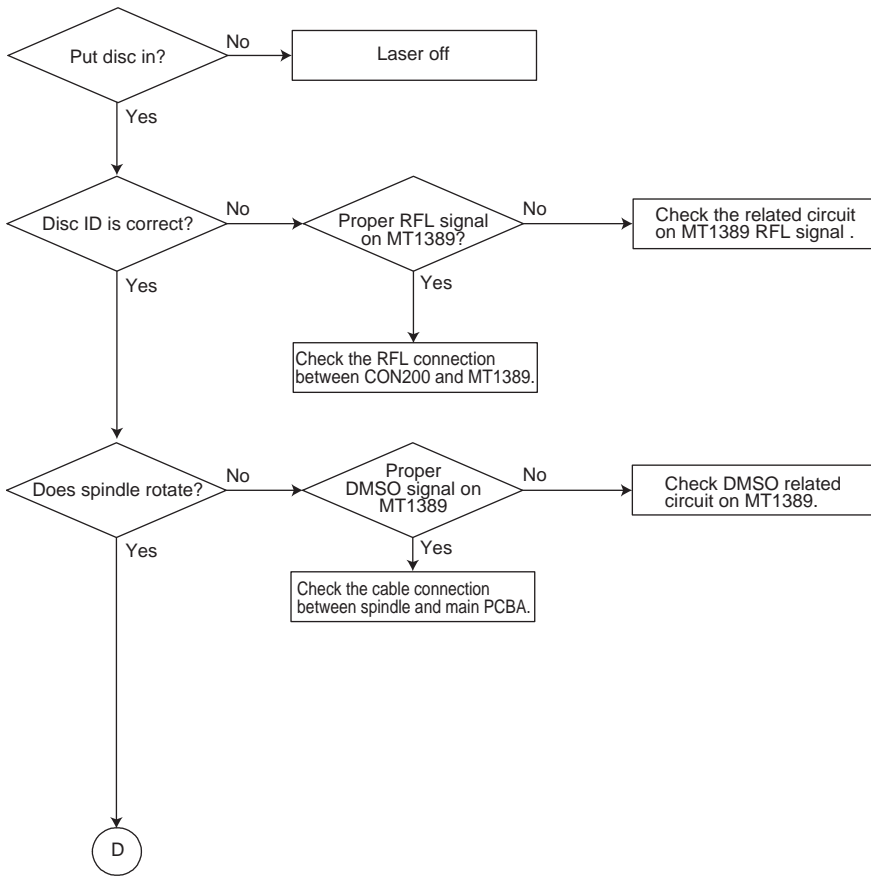

B.

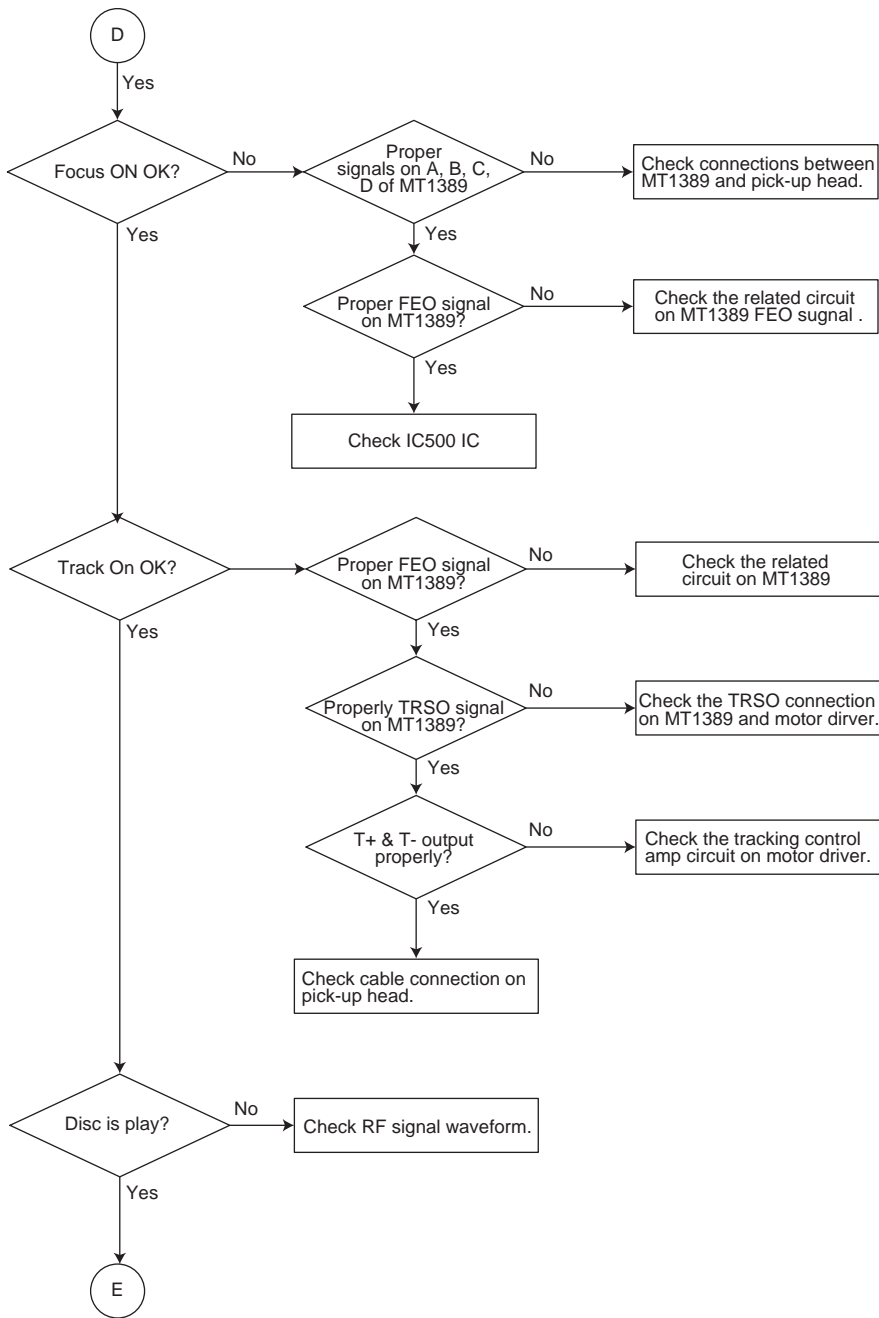

C.

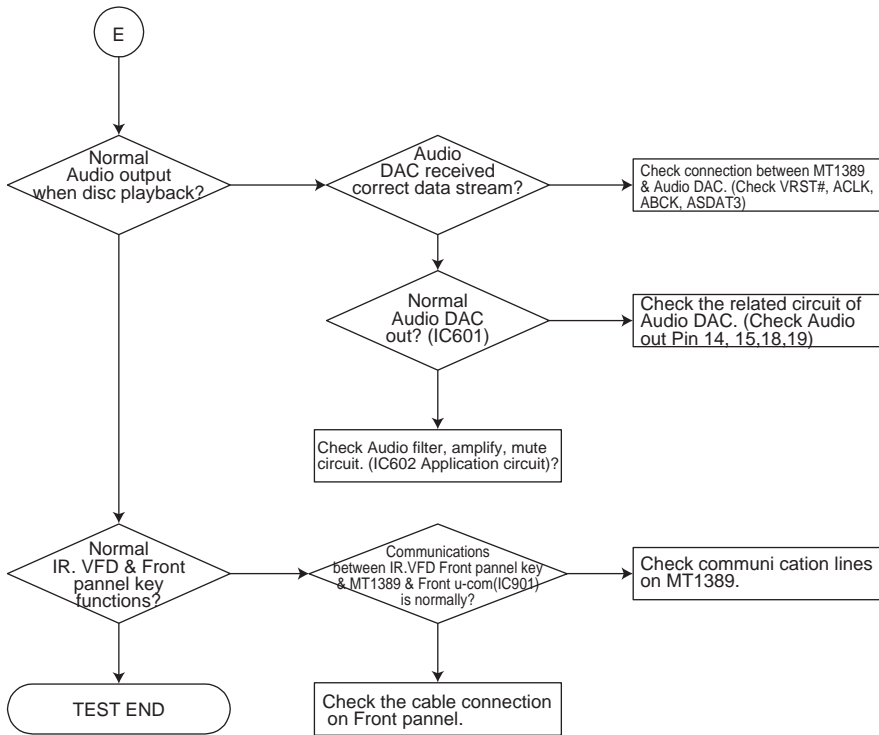

*** Charging Circuit**

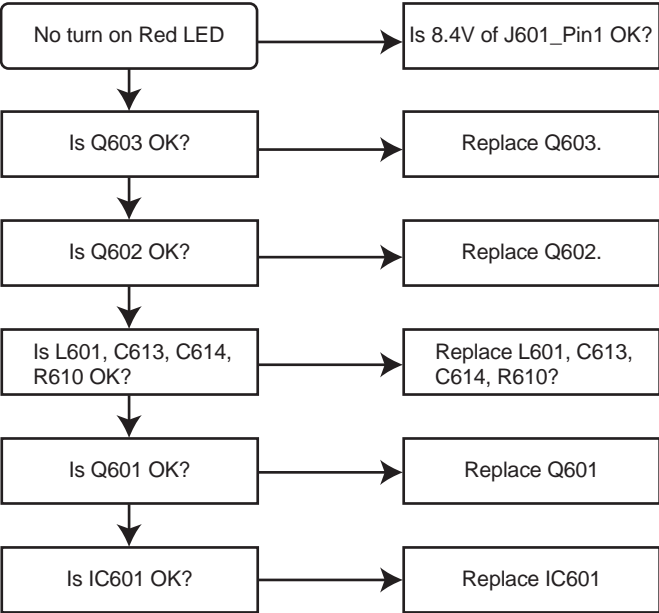

2. POWER(DC-DC CONVERTER)BLOCK DIAGRAM

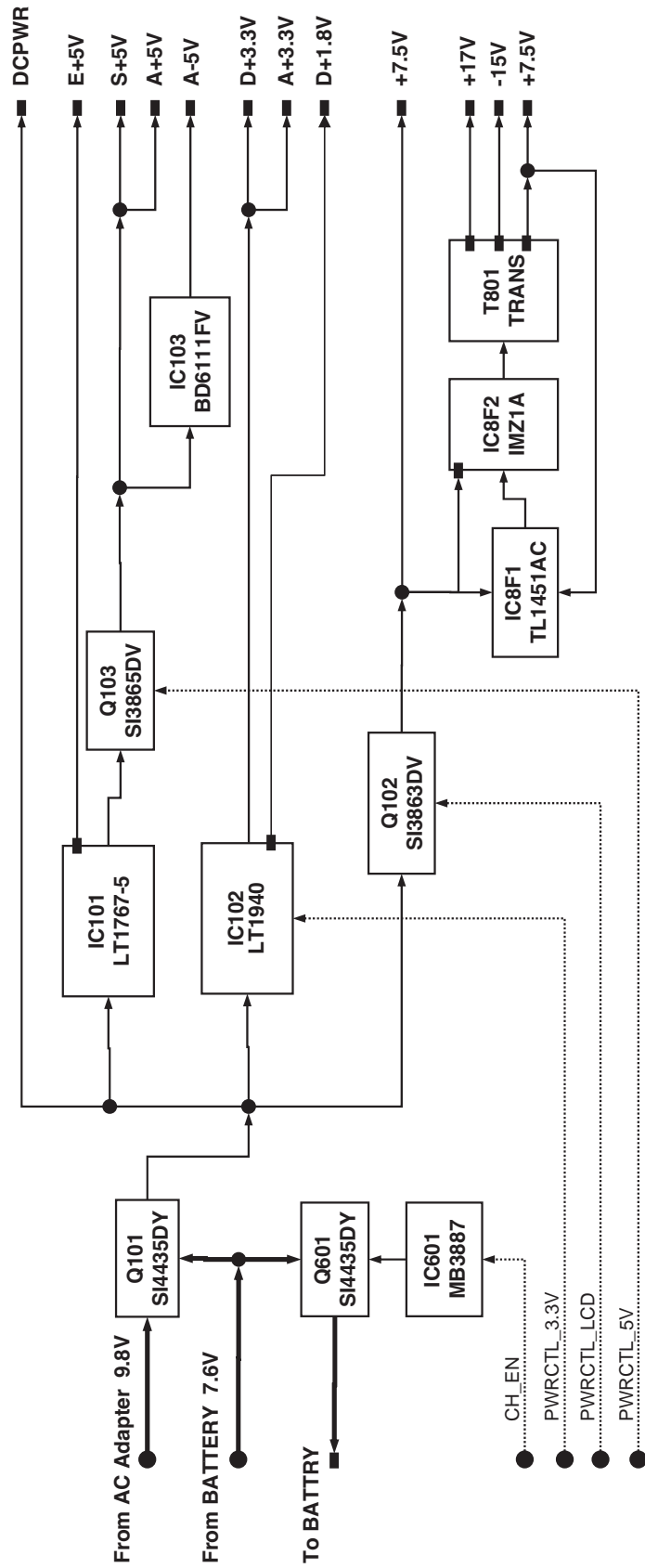

3. AUDIO/VIDEO BLOCK DIAGRAM

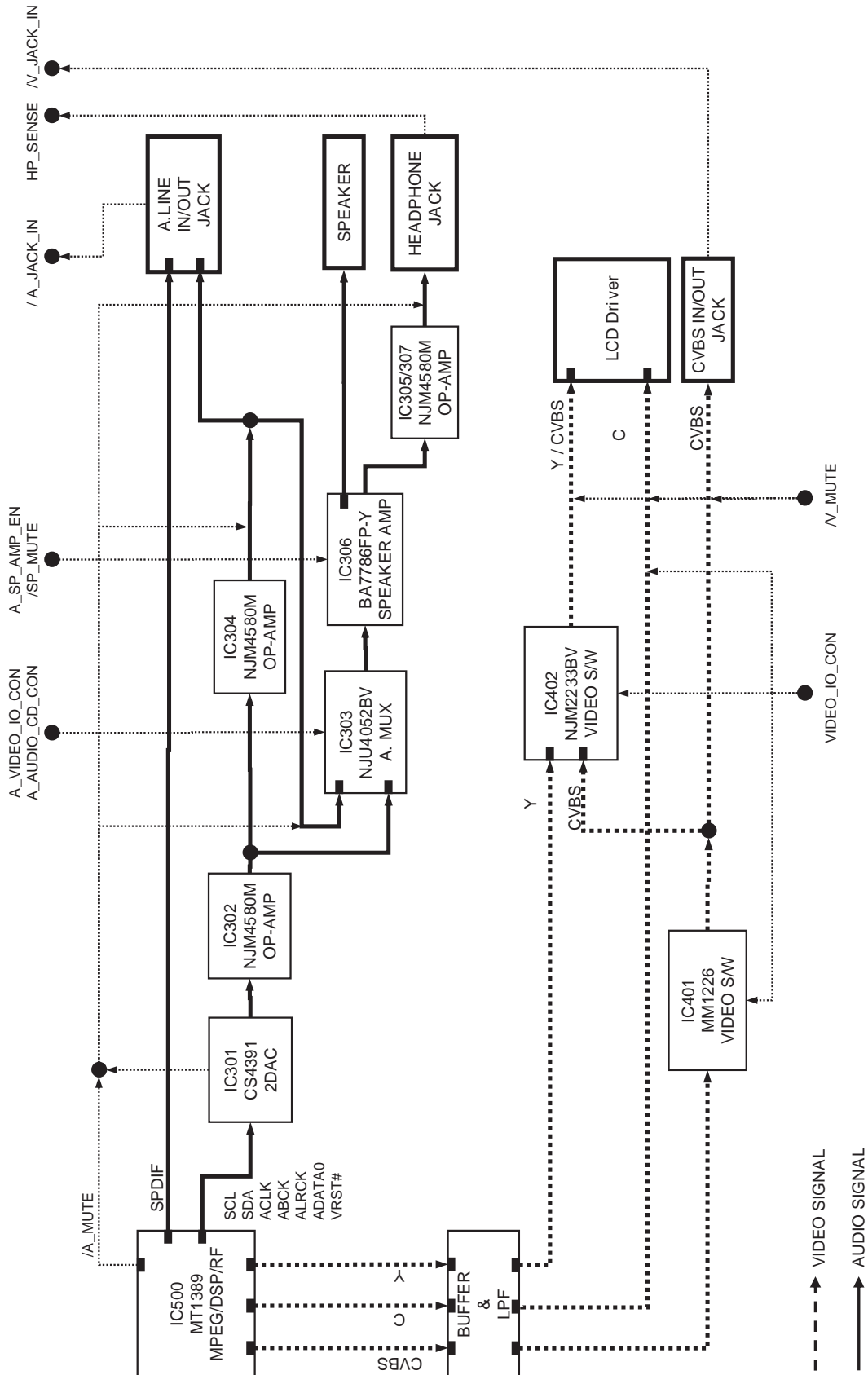

LCD CIRCUIT DIAGRAM

LCD1 CIRCUIT DIAGRAM

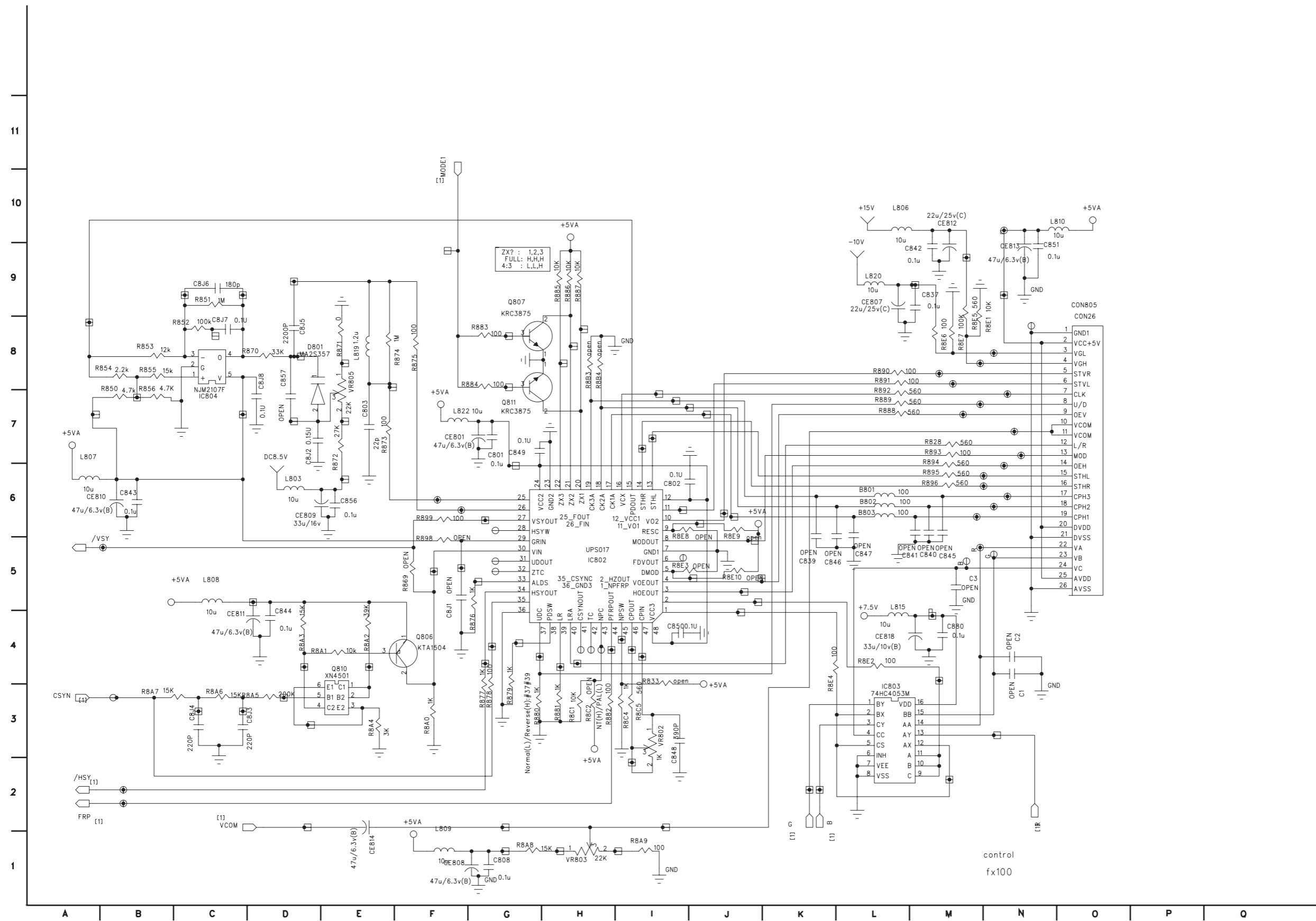

LCD2 CIRCUIT DIAGRAM

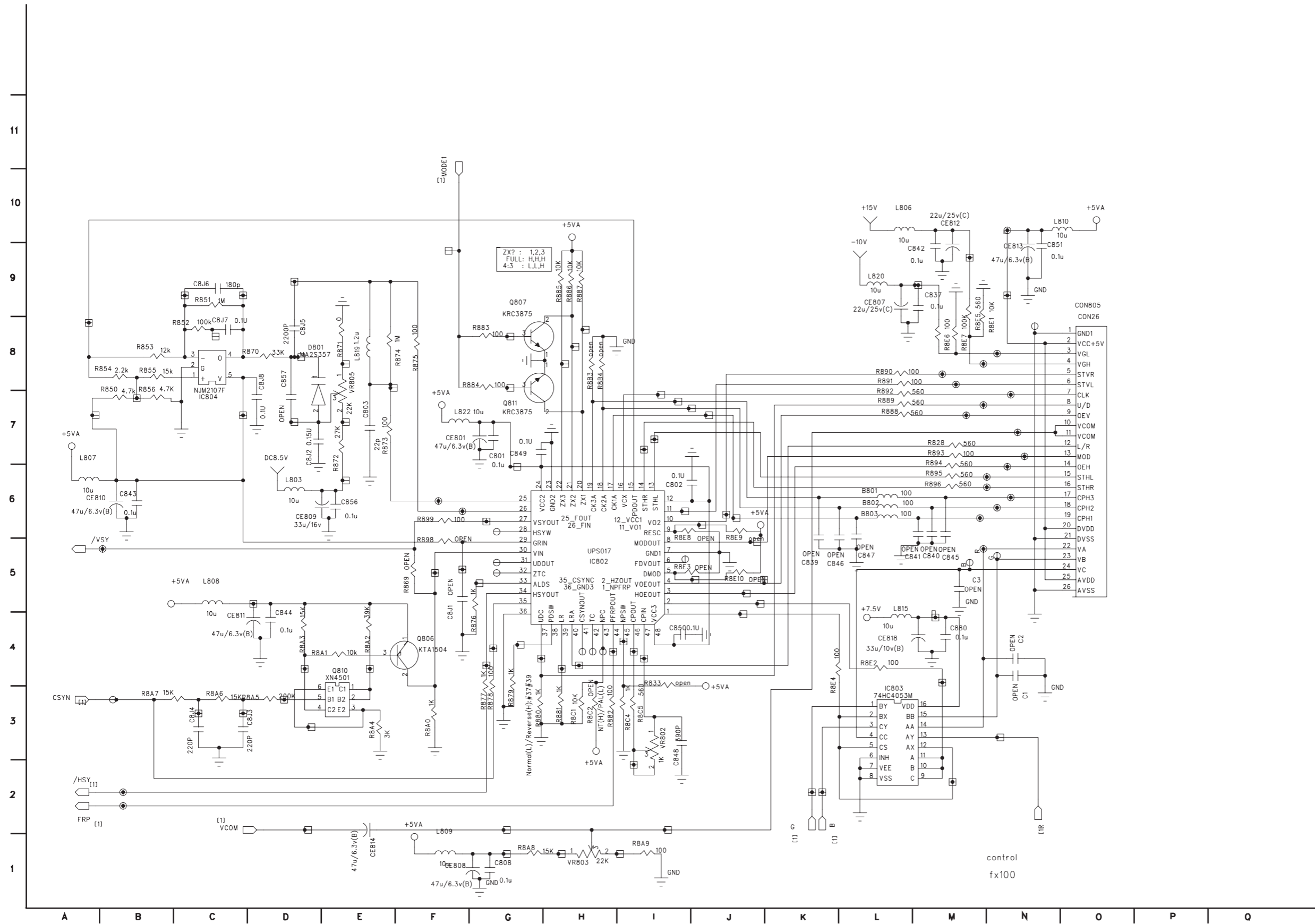

LCD3 CIRCUIT DIAGRAM

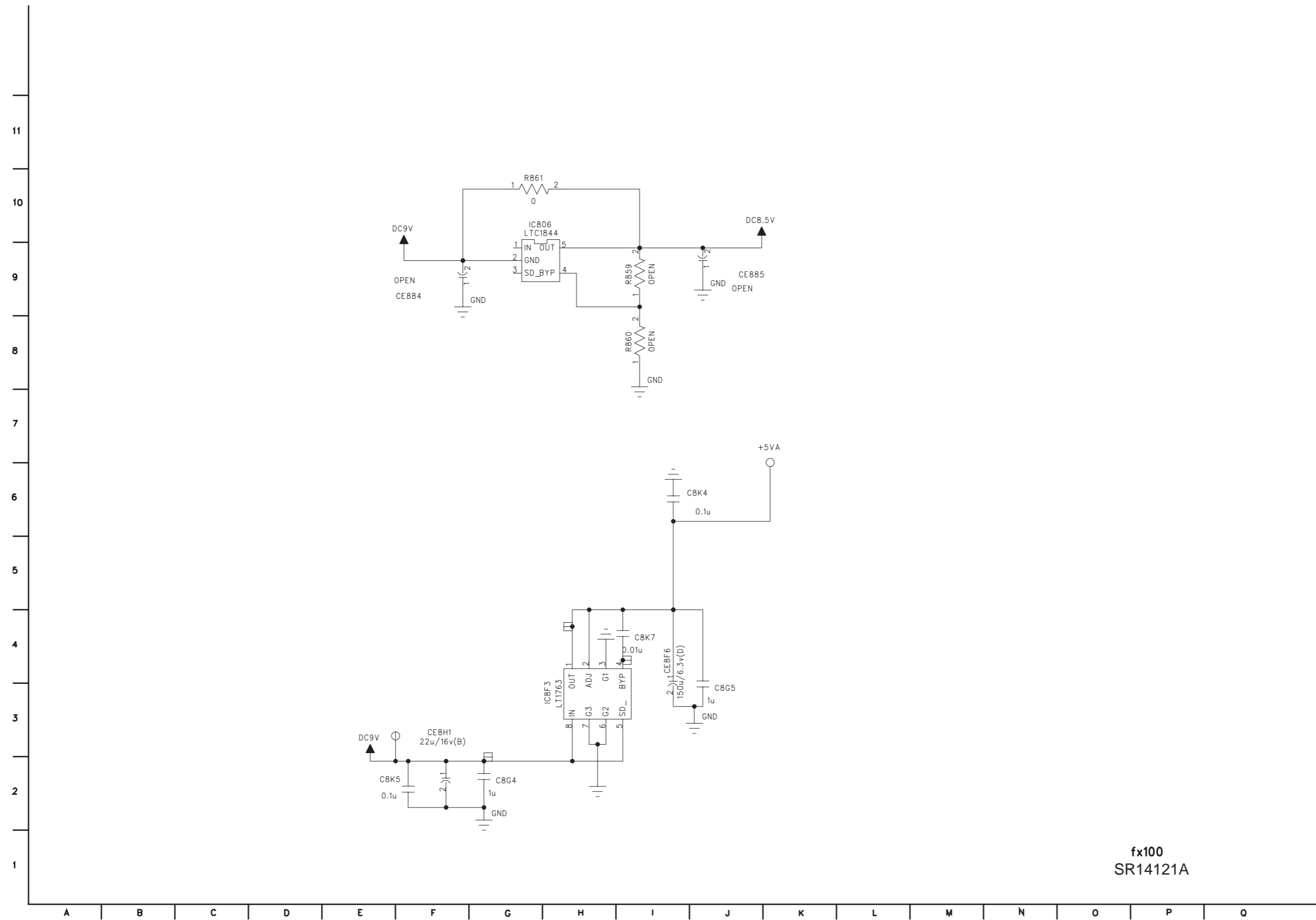

fx100
SR14121A

LCD VOLTAGE SHEET

IC801 IR3Y29BM

PIN NO	VOLT	WAVEFORM
1	2.5	Y signal(0.5)
2	3.1	
3	2.5	Y signal(0.5)
4	0.2	
5	2.8	C signal(0.5)
6	3.6	
7	3.5	
8	1	
9	2	
10	2	
11	2.1	
12	3	
13	3.2	
14	4.3	CLK(0.4)
15	2.6	
16	3	CLK(0.4)
17	0	
18	0	
19	4.4	R(0.6-4.4)
20	2.9	
21	4.4	G(0.6-4.4)
22	2.9	
23	7.5	VCC
24	4.4	B(0.6-4.4)
25	2.9	
26	2.5	
27	2.5	
28	2.5	
29	1.9	
30	2.5	
31	1.7	
32	2.6	HQ(0-2.6)
33	2.6	HQ(0-2.6)
34	3.4	SYNC(0-3.4)
35	3	C.SYNC
36	2.4	Y signal(0.5)
37	2.1	
38	4.7	COM(3-4.7)
39	0	
40	2	
41	2	
42	2	
43	5	VCC
44	1.3	
45	2.7	
46	2.9	
47	3.2	
48	2.7	

PIN NO	VOLT	WAVEFORM
1	0	
2	3.3	HD(0-3.3)
3	0	
4	0	
5	3.3	VD(0-3.3)
6	2.8	HQ-OUT
7	2.8	
8	0	
9	3.2	
10	0	
11	0	
12	0	
13	2.7	
14	2.8	0-2.8
15	0	
16	2.6	0-2.6
17	2.6	0-2.6
18	2.6	0-2.6
19	2.6	0-2.6
20	0	
21	2.6	0-2.6
22	0	
23	2.6	0-2.6
24	2.6	0-2.6
25	2.6	CLK 0-2.6
26	0	
27	2.6	CLK 0-2.6
28	0	
29	2.6	CLK 0-2.6
30	3.3	VCC
31	0	
32	3.3	VCC
33	1.6	
34	3.3	VCC
35	3.3	VCC
36	3.3	VCC
37	2.6	VCC
38	0	
39	2.2	
40	3.3	
41	0	
42	3.3	
43	3.3	
44	0	
45	0	
46	0	
47	3.3	
48	0	

LCD P.C. BOARD

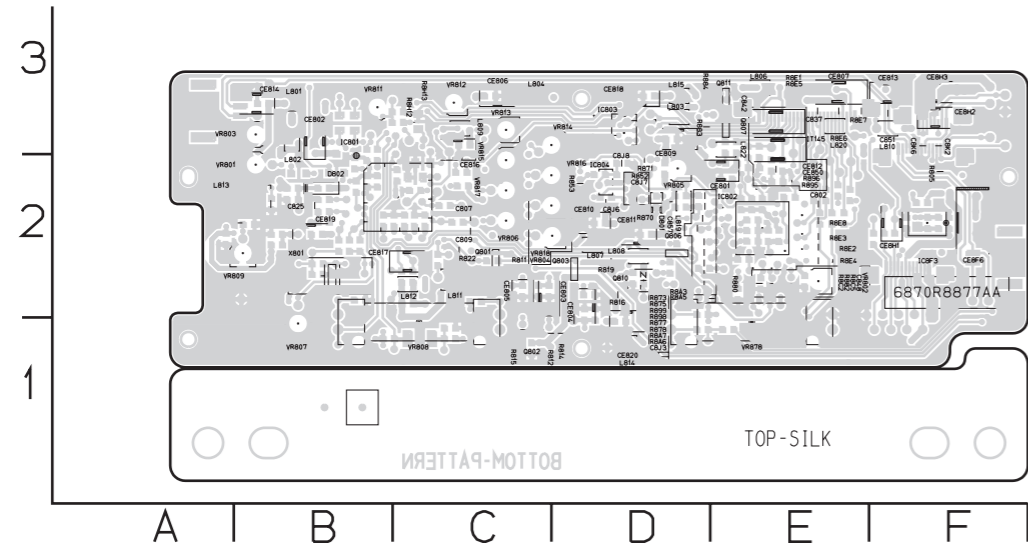

LOCATION GUIDE

C802	E2	CE8H1	F2	IT3	B2	L822	E3	R8A7	D2
C807	C2	CE8H2	F3	IT33	D2	Q801	C2	R8C2	E2
C809	C2	CE8H3	F3	IT36	B2	Q802	C1	R8C5	E2
C825	B2	D801	D2	IT40	C3	Q803	D2	R8E1	E3
C837	E3	D802	B2	IT41	C3	Q806	D2	R8E2	E2
C842	E3	IC801	C2	IT50	D2	Q807	E3	R8E3	E2
C848	E2	IC802	E2	IT64	C2	Q810	D2	R8E4	E2
C851	F3	IC803	D3	IT67	C2	Q811	E3	R8E5	E3
C857	D2	IC804	D2	IT69	C2	R805	F2	R8E6	E3
C8J3	D2	IC8F3	F2	IT71	E2	R811	C2	R8E7	E3
C8J6	D2	IT102	D2	IT72	C3	R812	C1	R8E8	E2
C8J7	D2	IT12	B2	IT74	C2	R814	D1	R8H12	C3
C8J8	D2	IT122	E2	IT76	C3	R815	C1	R8H13	C3
CK2	F3	IT124	E2	IT78	F3	R816	D2	VR801	B2
CK6	F3	IT130	E2	IT79	C3	R819	D2	VR802	E2
CE801	E2	IT131	E2	IT85	E2	R822	C2	VR803	B3
CE802	B3	IT137	E2	IT9	B3	R852	D2	VR804	D2
CE803	C2	IT138	E2	IT96	D3	R853	D2	VR805	D2
CE804	D2	IT139	E2	IT98	E2	R870	D2	VR806	C2
CE805	C2	IT140	E2	L801	B3	R871	D2	VR807	B1
CE806	C3	IT141	E2	L802	B3	R873	D2	VR808	C1
CE807	E3	IT142	E2	L803	D3	R875	D2	VR809	B2
CE809	D3	IT145	E3	L804	C3	R877	D2	VR811	B3
CE810	D2	IT146	E3	L806	E3	R878	D2	VR812	C3
CE811	D2	IT150	D3	L807	D2	R880	E2	VR813	C3
CE812	E3	IT152	D2	L808	D2	R882	E2	VR814	D3
CE813	F3	IT158	D3	L809	C3	R883	D3	VR815	C2
CE814	B3	IT159	F2	L810	F3	R884	D3	VR816	D2
CE816	C3	IT160	F2	L811	C2	R895	F2	VR817	C2
CE817	C2	IT17	B2	L812	C2	R896	E2	VR818	D2
CE818	D3	IT18	B2	L813	B2	R898	D2	VR878	E1
CE819	B2	IT23	B2	L814	D1	R899	D2	X801	B2
CE820	D1	IT25	C2	L815	D3	R8A3	D2		
CE850	E3	IT26	D2	L819	D2	R8A5	D2		
CE8F6	F2	IT27	D2	L820	E3	R8A6	D2		

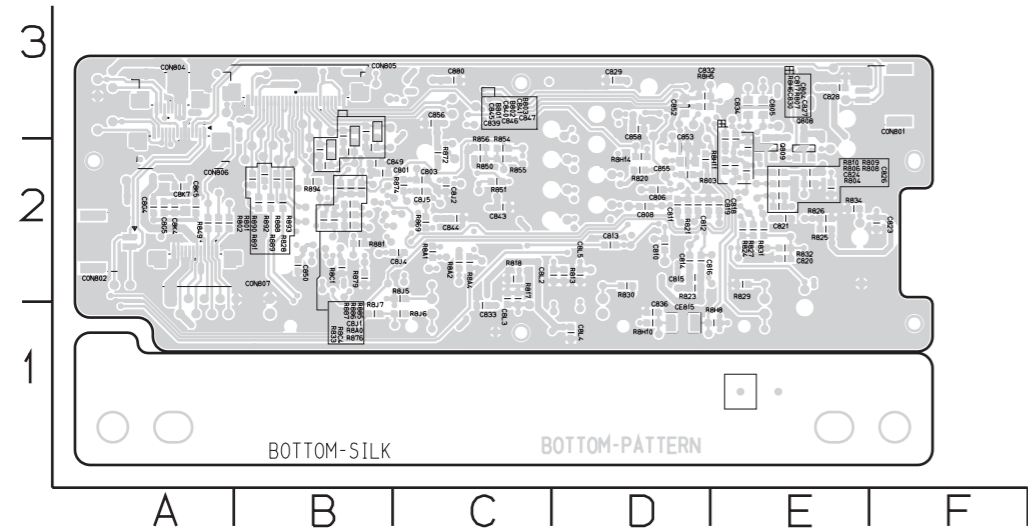

LOCATION GUIDE

B801	B2	C841	B3	IT1	E3	IT136	B2	IT47	C2	IT89	A2	R851	C2	R8J7	B1	TP45	B3
B802	B3	C843	C2	IT10	E2	IT14	D2	IT48	B2	IT95	B3	R854	C2	TP1	A2	TP46	B3
B803	B3	C844	C2	IT100	B2	IT143	B2	IT49	B2	IT97	B3	R855	C2	TP10	A3	TP47	B2
C801	B2	C845	B2	IT101	C2	IT148	C3	IT5	E3	IT99	B2	R856	C2	TP11	A3	TP48	B2
C803	C2	C846	B2	IT103	C2	IT149	C3	IT51	E2	Q808	E2	R869	C2	TP12	E3	TP5	E2
C804	E2	C847	B2	IT104	C2	IT15	E2	IT52	E1	Q809	E2	R872	C2	TP13	A2	TP50	B2
C805	E3	C849	B2	IT105	C2	IT153	C3	IT53	E2	R801	A2	R874	C2	TP14	A2	TP52	A3
C806	D2	C850	B2	IT106	C2	IT154	C2	IT54	D2	R802	A2	R876	B2	TP15	C3	TP53	B3
C808	D2	C852	D3	IT107	C2	IT155	C2	IT55	E2	R803	D2	R879	B2	TP17	D2	TP54	B2
C810	D2	C853	D2	IT109	B2	IT156	C2	IT56	E2	R804	E2	R881	B2	TP18	B3	TP55	B2
C811	D2	C855	D2	IT11	E3	IT157	C2	IT57	D2	R806	E2	R885	B2	TP19	A2	TP6	C1
C812	D2	C856	C3	IT110	C2	IT16	E2	IT58	D2	R807	E2	R886	B2	TP2	A1	TP62	D3
C813	D2	C858	D3	IT111	C2	IT19	E2	IT59	C1	R808	E2	R887	B2	TP20	B3	TP7	D3
C814	D2	C880	C3	IT112	C2	IT2	C2	IT6	E3	R809	E2	R888	B2	TP21	B3	TP72	D2
C815	D2	C8G4	A2	IT113	C2	IT20	E3	IT60	C1	R810	E2	R889	B2	TP22	B2	TP73	D3
C816	D2	C805	A2	IT114	C2	IT21	E2	IT61	C2	R813	D2	R890	B2	TP23	D2	TP74	D3
C817	E2	C8J1	B2	IT115	C2	IT22	E2	IT62	D2	R817	C2	R891	B2	TP24	B2	TP75	D2
C818	E2	C8J2	C2	IT116	B2	IT24	E2	IT63	D2	R818	C2	R892	B2	TP25	B3	TP76	D2
C819	D2	C8J4	C2	IT117	B2	IT28	D1	IT65	D2	R820	D2	R893	B2	TP26	A1	TP77	D2
C820	E2	C8J5	C2	IT118	C2	IT29	D1	IT66	D2	R821	D2	R894	B2	TP27	C3	TP78	D2
C821	E2	CK4	A2	IT119	B2	IT30	D2	IT68	D2	R823	D2	R8A0	B2	TP28	A2	TP79	D2
C823	F2	CK5	A2	IT120	C2	IT31	E2	IT7	E3	R824	E2	R8A1	C2	TP29	A2	TP8	E2
C824	E2	CK7	A2	IT121	B2	IT32	A2	IT70	D2	R825	E2	R8A2	C2	TP3	C2	TP80	D2
C826	E2	CK2	D2	IT123	B2	IT34	E2	IT73	D2	R826	E2	R8A4	C2	TP30	A3	TP82	E2
C827	E2	CK3	C2	IT125	B2	IT35	E2	IT75	D3	R827	E2	R8C1	B2	TP31	A3	TP83	E2
C828	E3	CK4	D1	IT126	B2	IT37	D3	IT77	D3	R828	B2	R8C4	B2	TP32	A3	TP84	E3
C829	D3	CK5	D2	IT127	B2	IT38	D3	IT8	E3	R829	E2	R8H10	D1	TP33	A1	TP9	B3
C830	E2	CE815	D1	IT128	B2	IT39	D2	IT80	B2	R830	D2	R8H11	D2	TP34	A1		
C832	D3	CON801	F3	IT129	B2	IT4	E3	IT81	E3	R831	E2	R8H14	D2	TP35	C3		
C833	C1	CON802	A2	IT13	E2	IT42	E3	IT83	D1	R832	E2	R8H5	D3	TP39	B2		
C834	E3	CON804	A3	IT132	B2	IT43	D2	IT84	D1	R833	B2	R8H6	E2	TP4	E3		
C836	D1	CON805	B3	IT133	B2	IT44	D2	IT86	B2	R834	E2	R8H8	E1	TP41	A3		
C839	B2	CON806	A2	IT134	C1	IT45	C2	IT87	B2	R849	A2	R8J5	C2	TP42	A2		
C840	B3	CON807	A2	IT135	B2	IT46	B2	IT88	A2	R850	C2	R8J6	C1	TP43	B2		

CIRCUIT DIAGRAMS

1. MAIN POWER CIRCUIT DIAGRAM

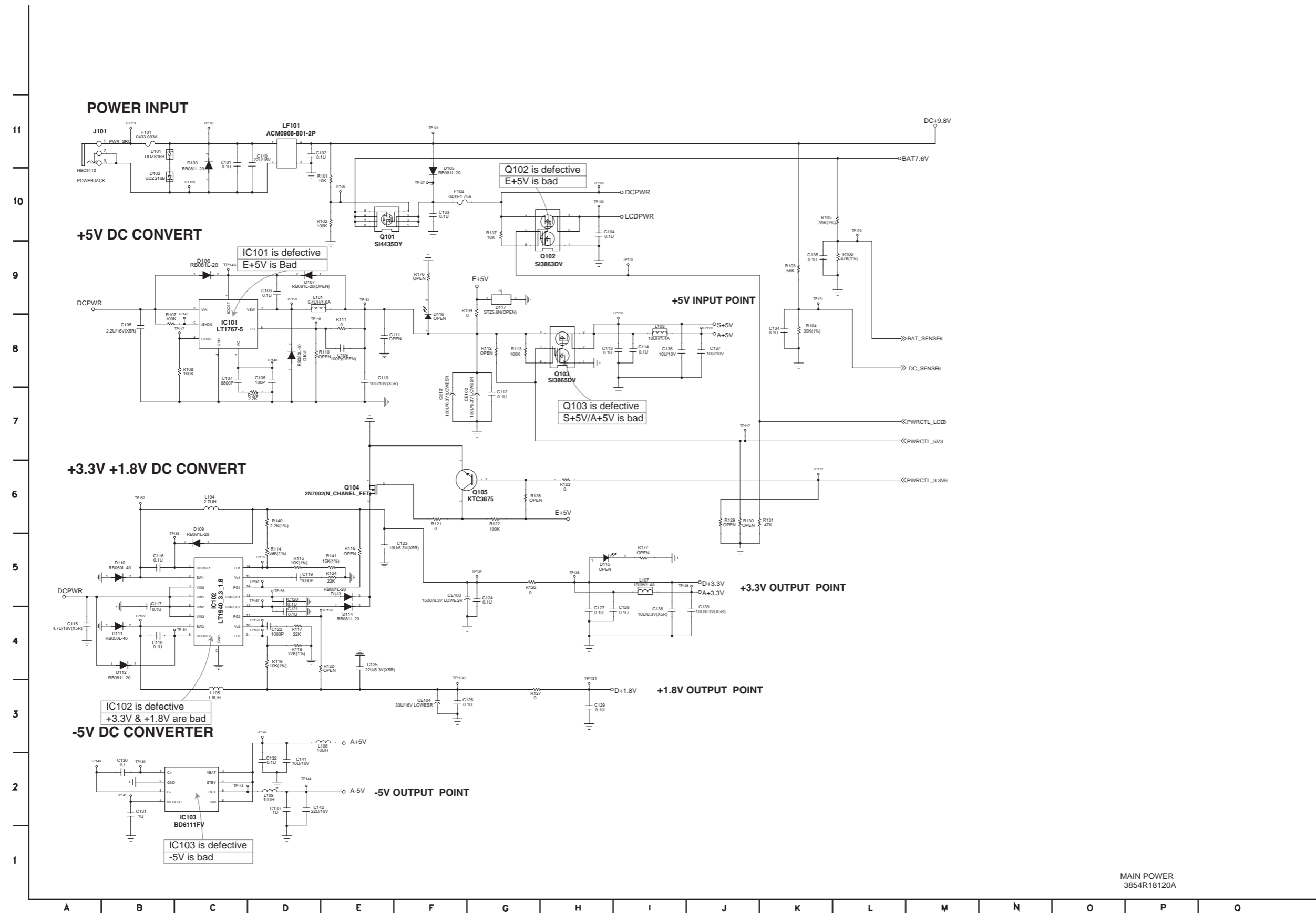

MAIN POWER
3854R18120A

2. SERVO CIRCUIT DIAGRAM

11

10

9

8

7

6

5

4

3

2

1

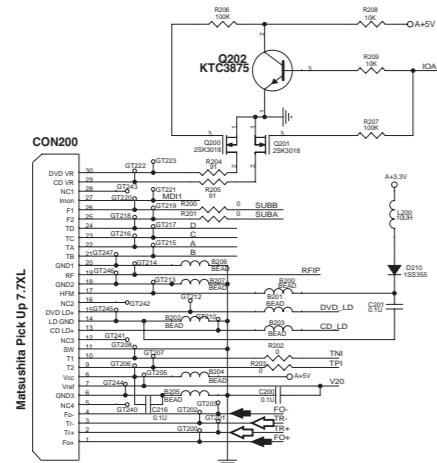

The countermeasure of static electricity

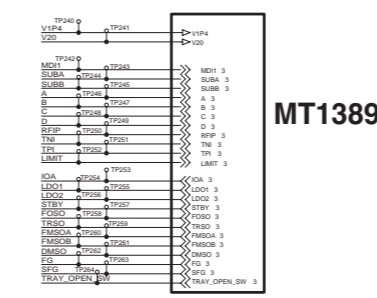
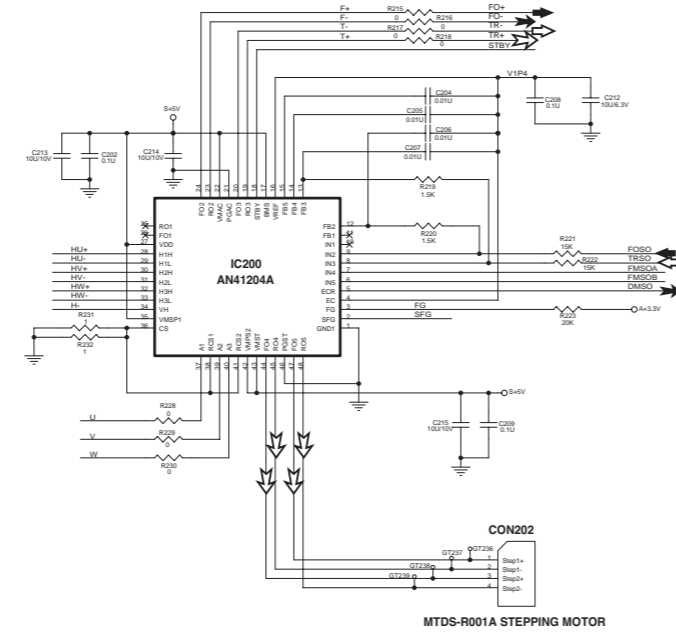
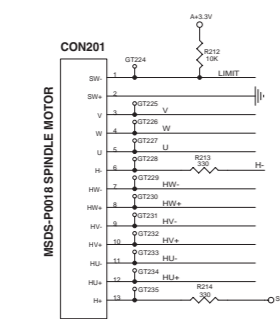
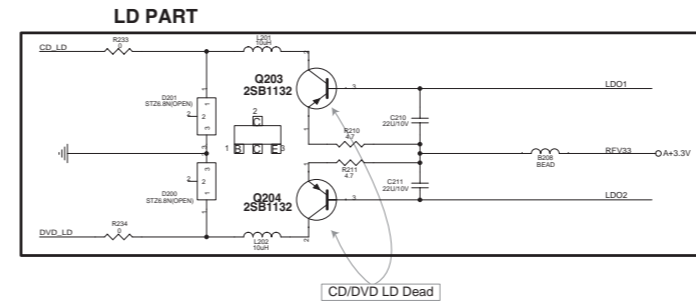
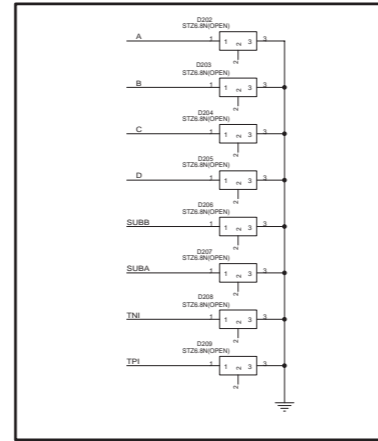

3. MAIN(MT1389) CIRCUIT DIAGRAM

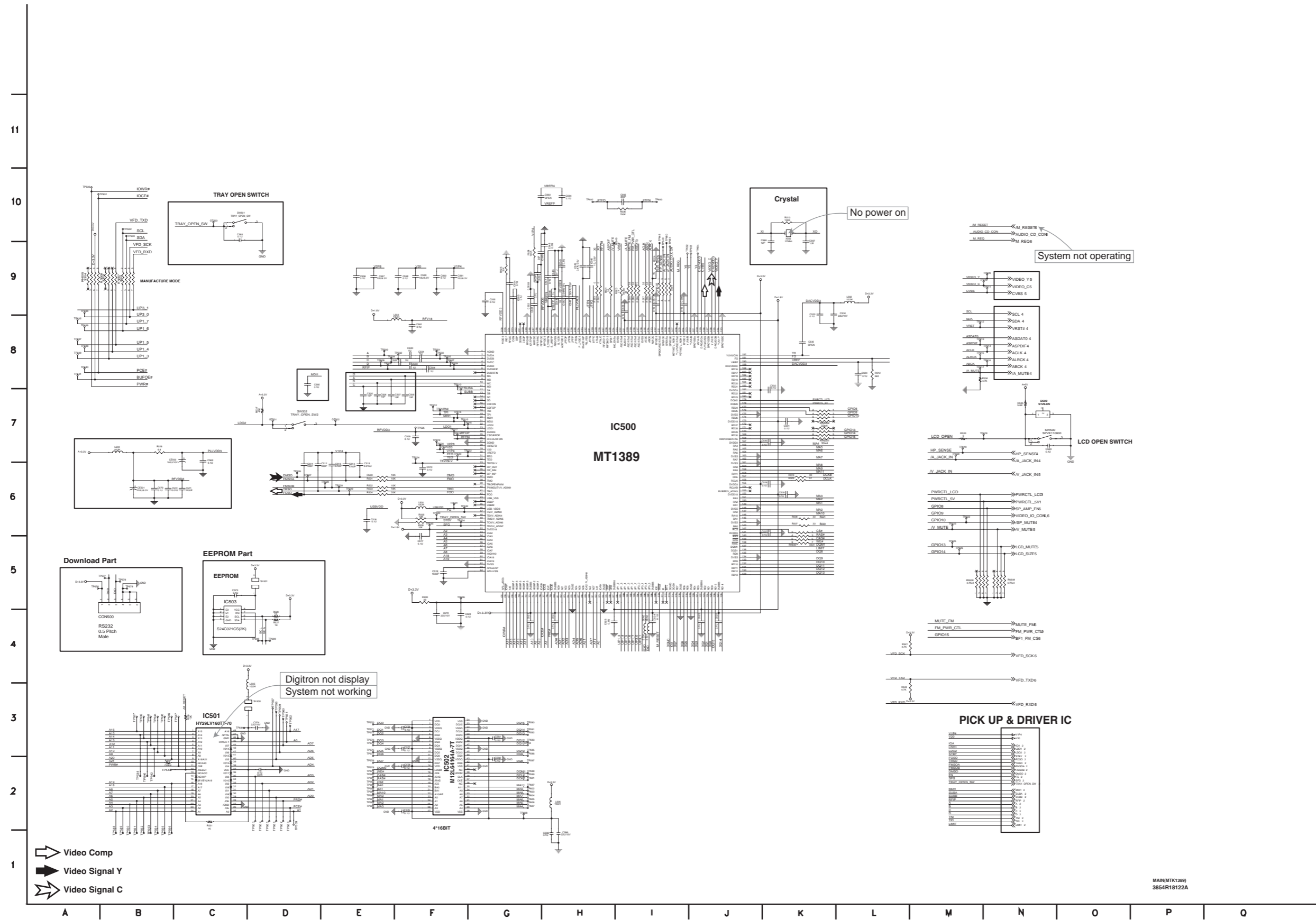

4. AUDIO CIRCUIT DIAGRAM

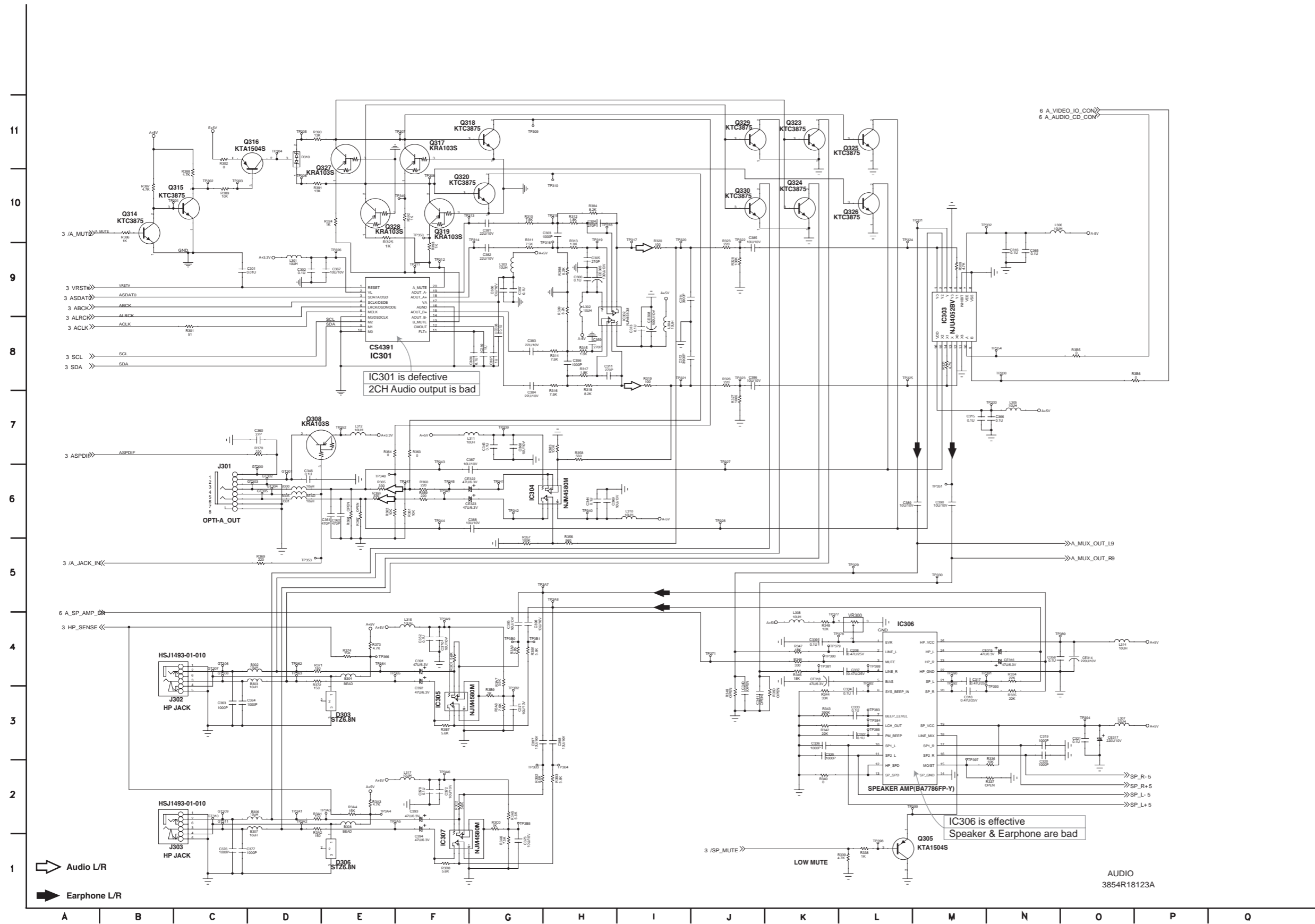

5. VIDEO CIRCUIT DIAGRAM

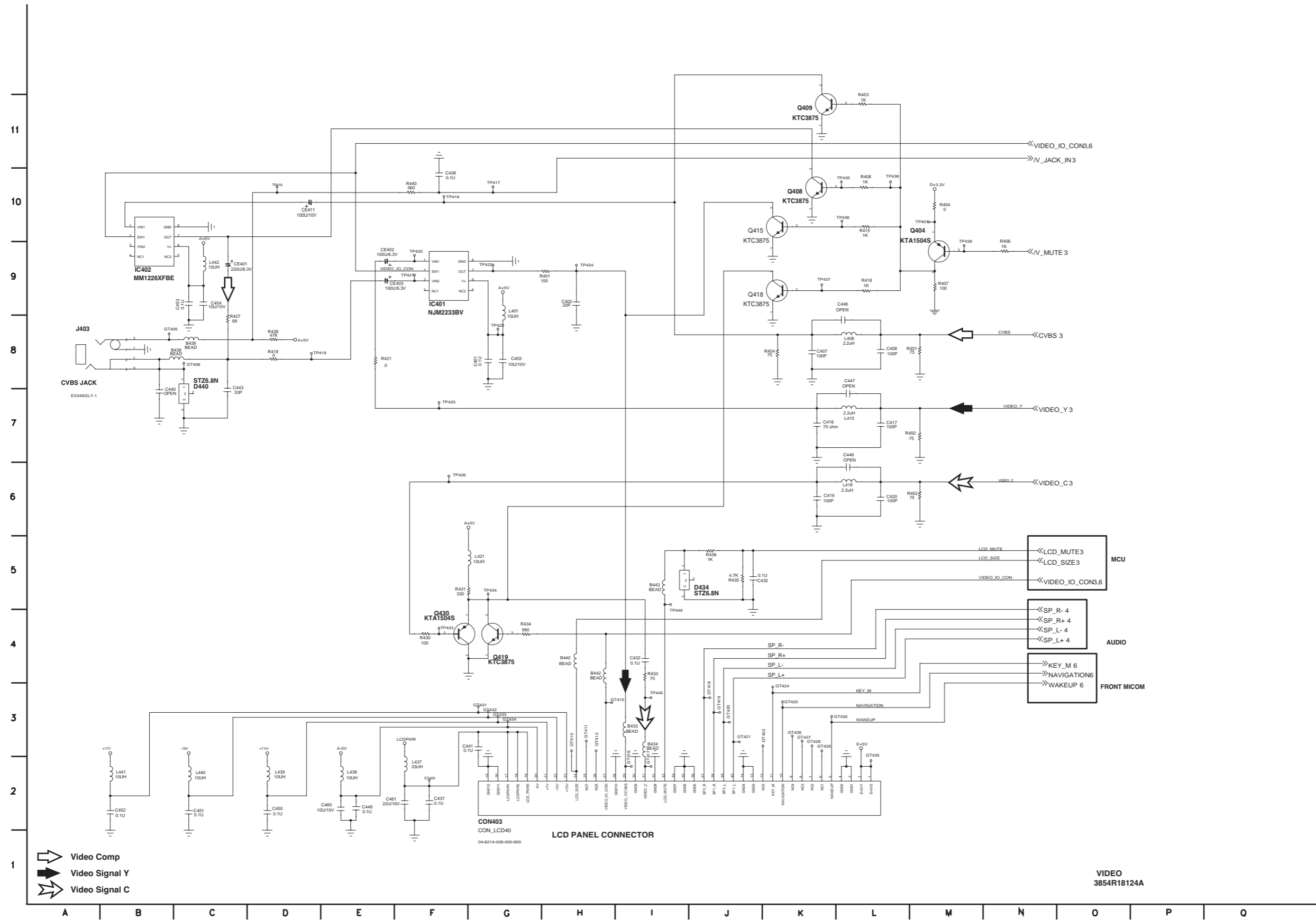

6. FRONT MICOM CIRCUIT DIAGRAM

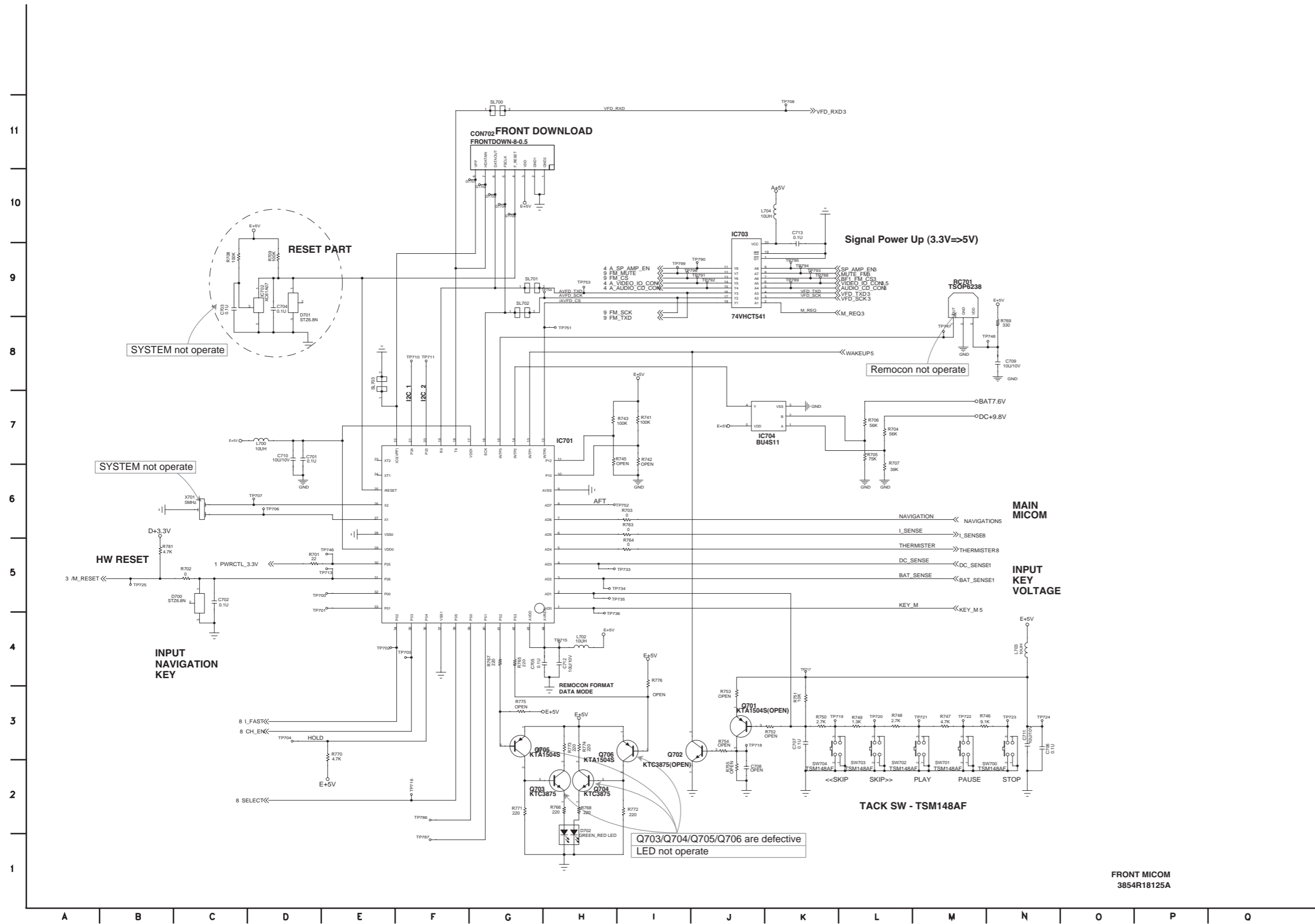

FRONT MICOM
3854R18125A

7. LCD POWER CIRCUIT DIAGRAM

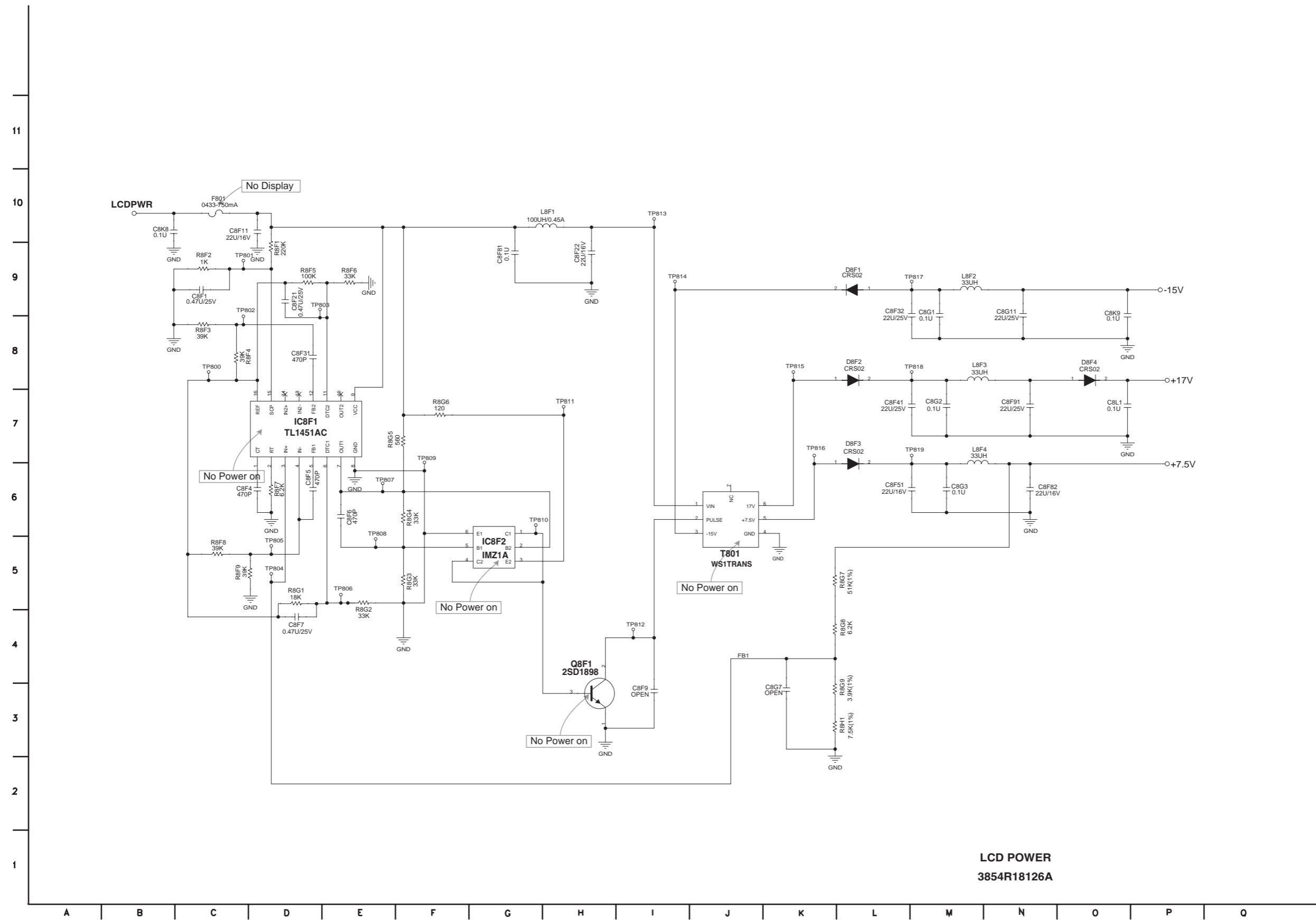

LCD POWER
3854R18126A

8. BATTERY CHARGE CIRCUIT DIAGRAM

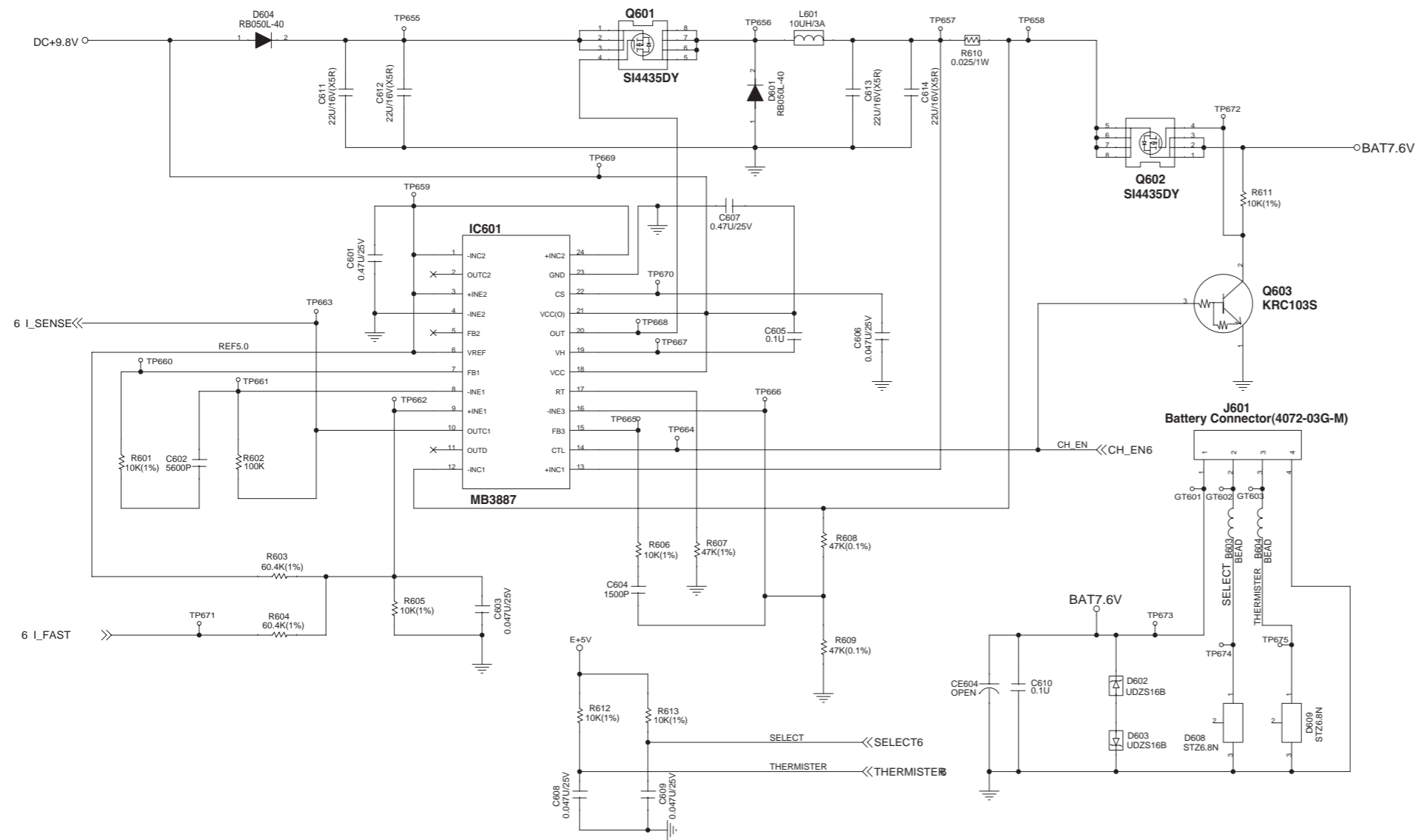

BATTETY_CHARGE
3854R18127A

9. KEY CIRCUIT DIAGRAM

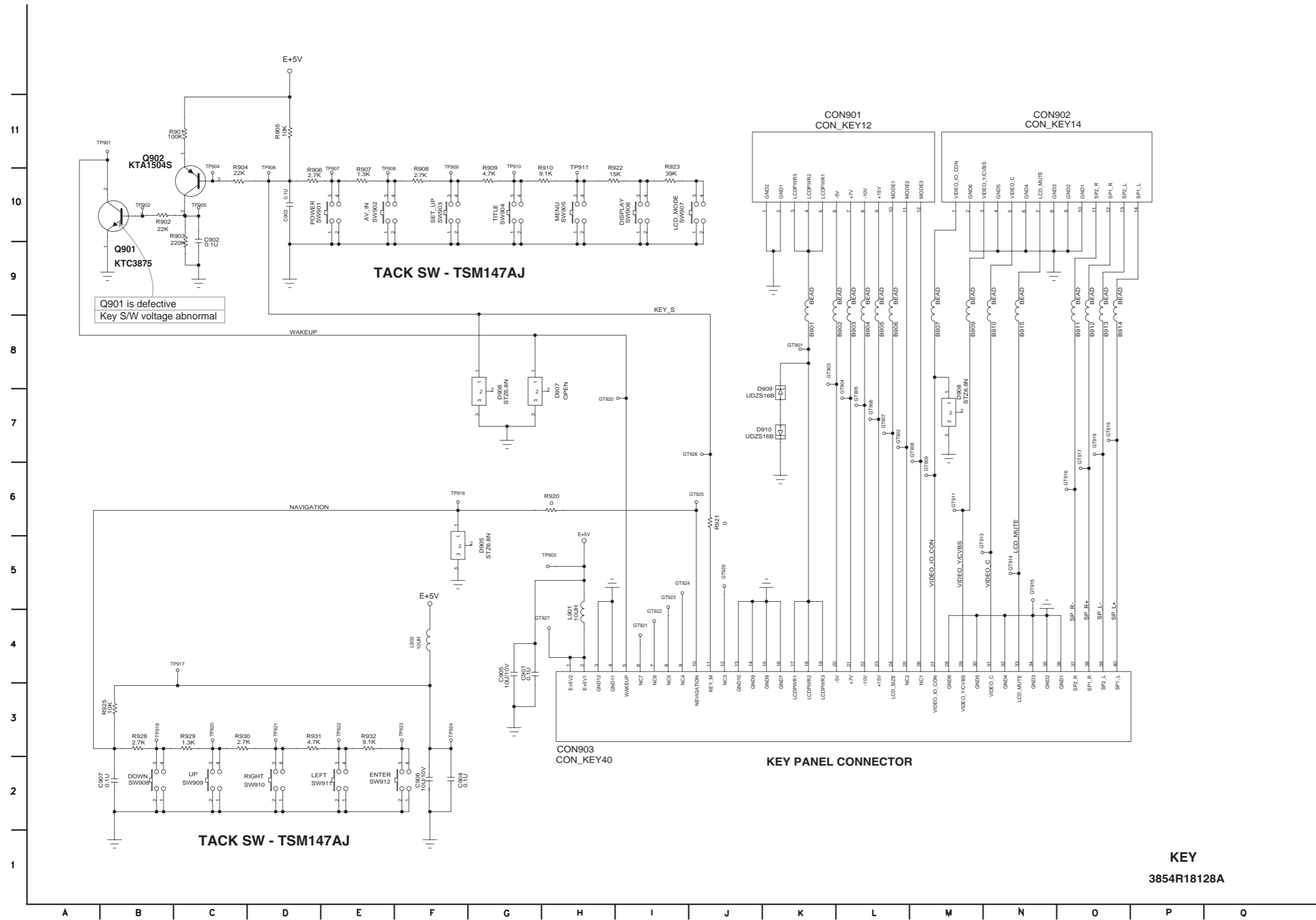

KEY
3854R18128A

DETAILS AND WAVEFORMS ON SYSTEM TEST AND DEBUGGING

1. SYSTEM 27MHz CLOCK,RESET,FLASH R/W SIGNAL

1) MT1389 main clock is at 27MHz(X500)

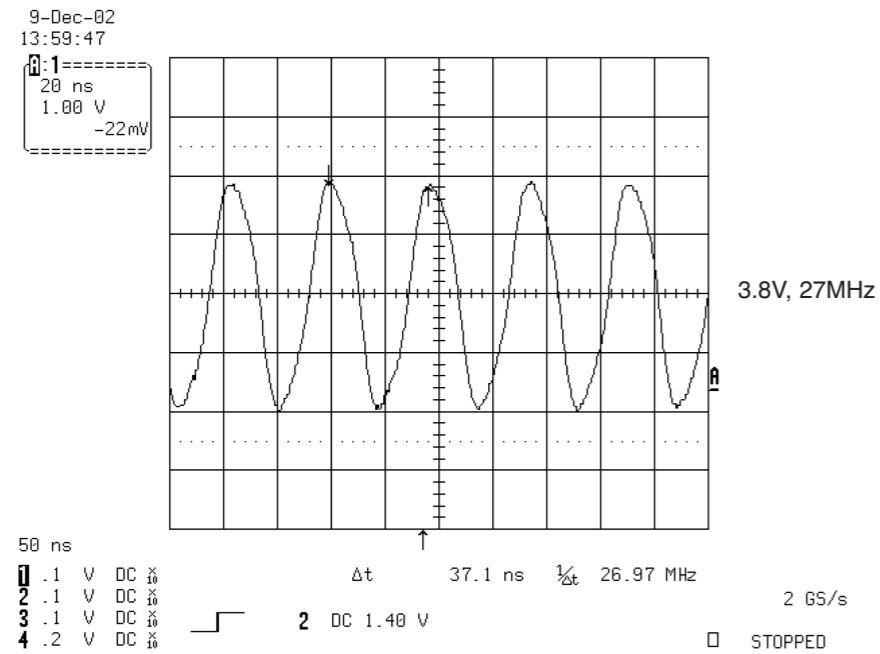

FIG 1-1

2. SDRAM CLOCK

1) MT1389 main clock is at 27MHz(X501)

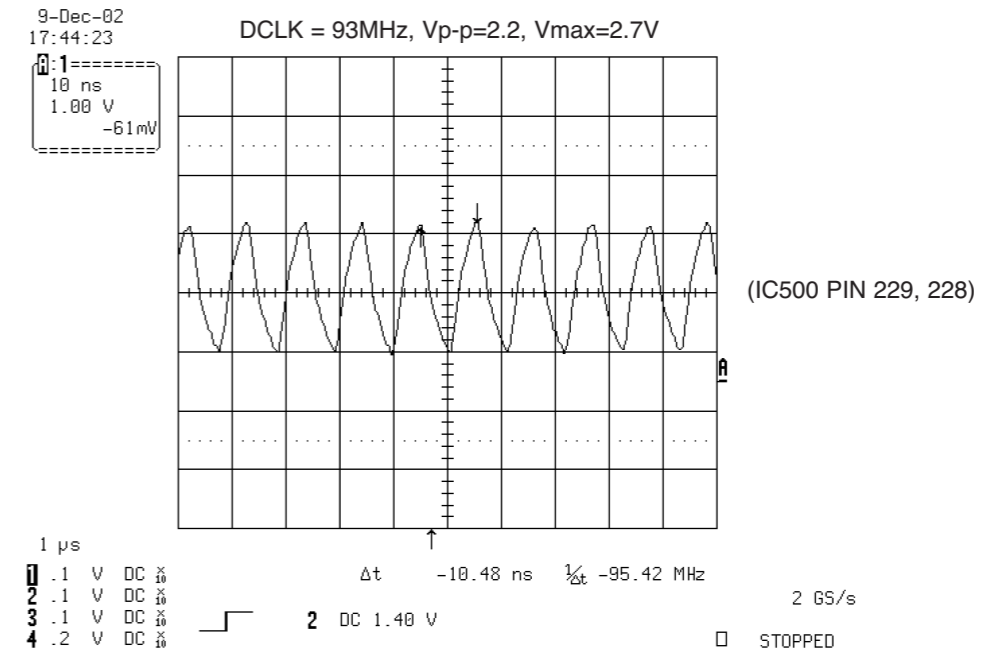

FIG 2-1

3. DISC TYPE JUDGEMENT WAVEFORM

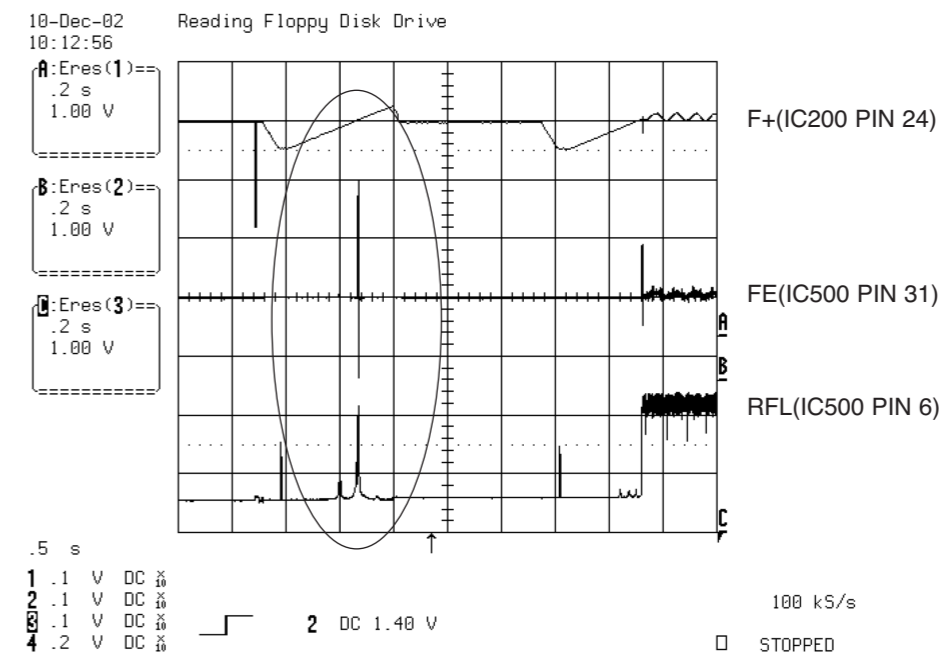

FIG 7-1 (DVD)

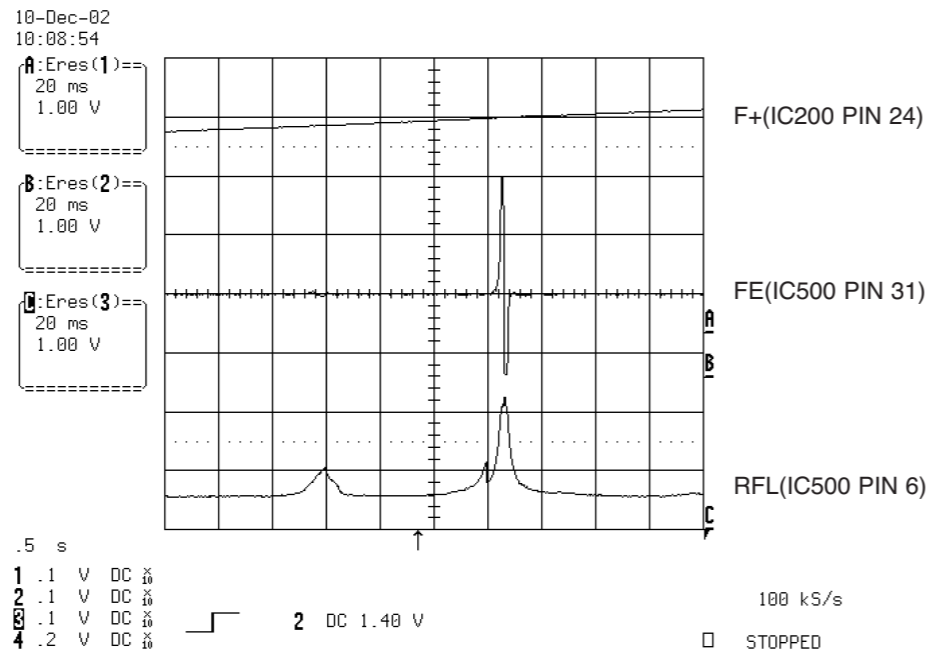

FIG 7-2 (DVD)

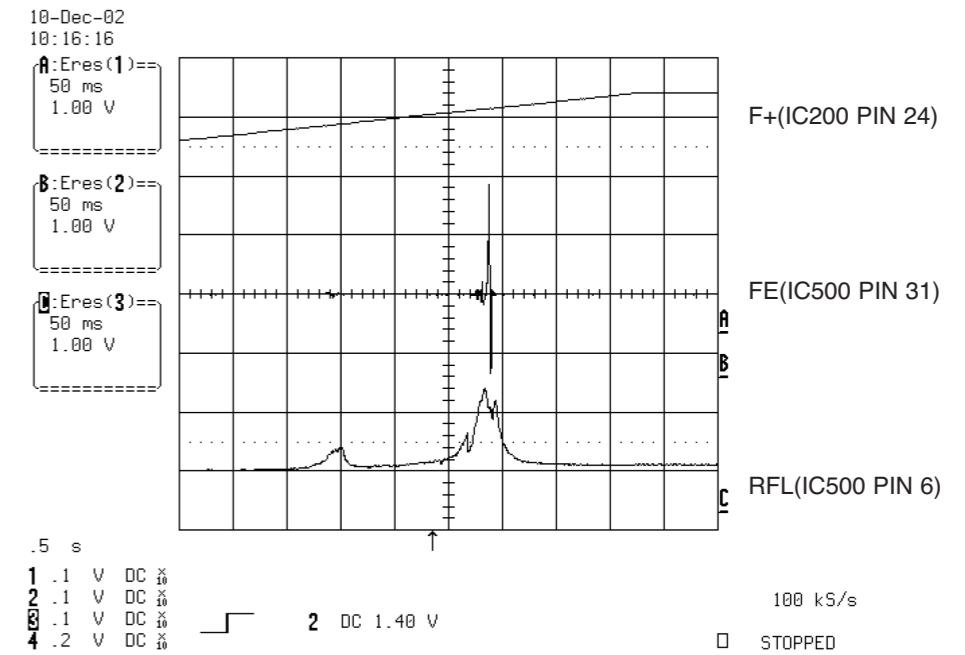

FIG 7-4 (CD)

4. FOCUS ON WAVEFORM

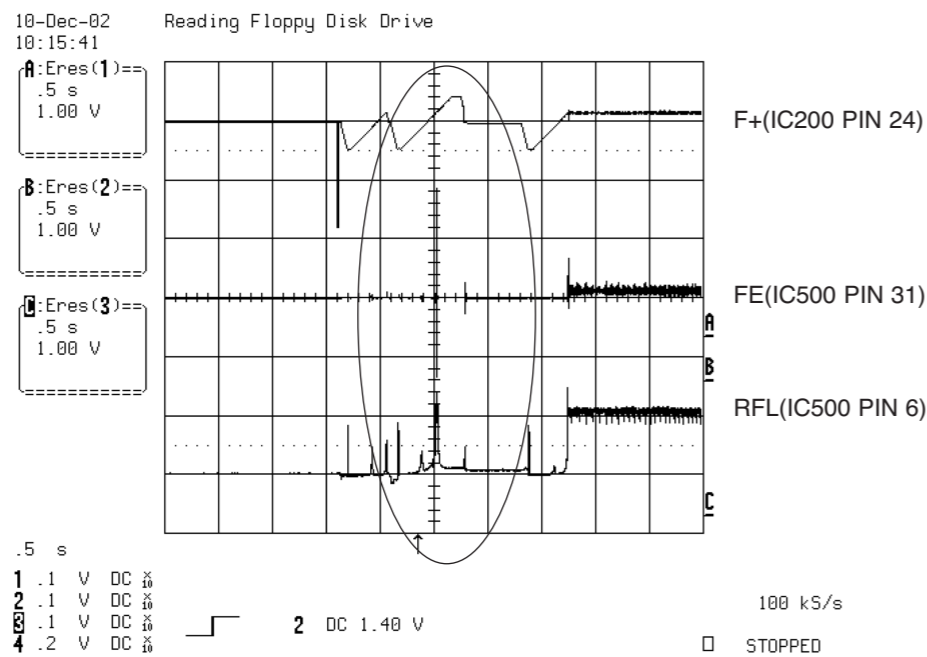

FIG 7-3 (CD)

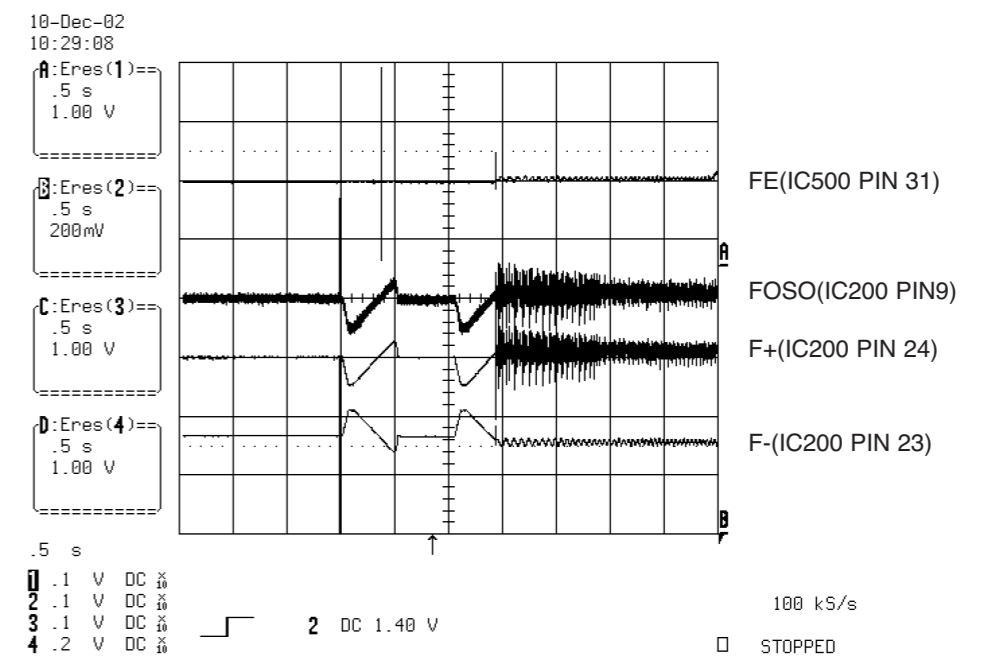

FIG 8-1 (DVD)

6. TRACKING CONTROL RELATED SIGNAL(System checking)

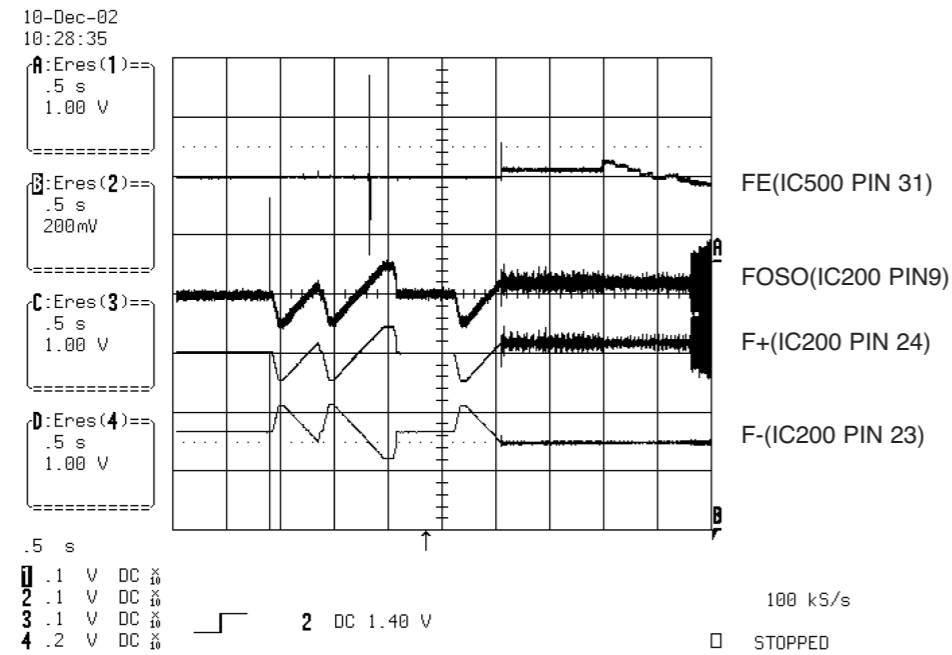

FIG 8-2 (CD)

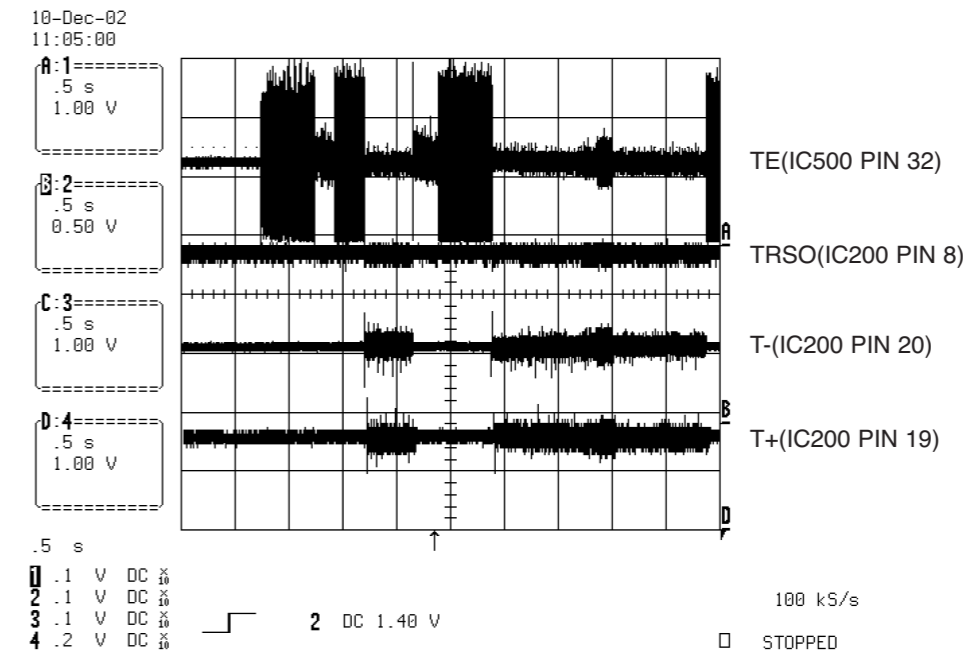

FIG 10-1(DVD)

5. SPINDLE CONTROL WAVEFORM (NO DISC CONDITION)

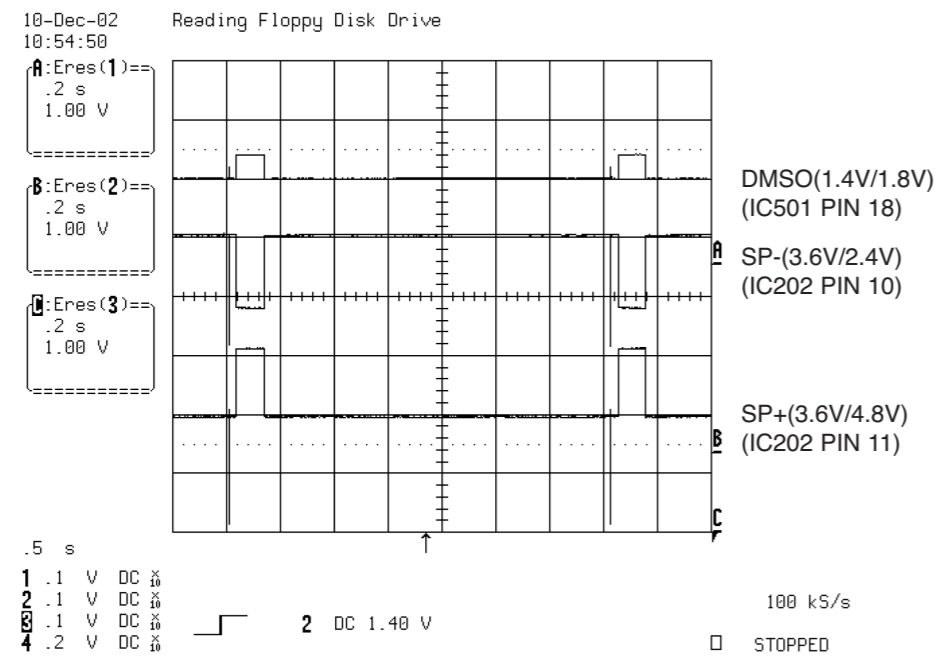

FIG 9-1

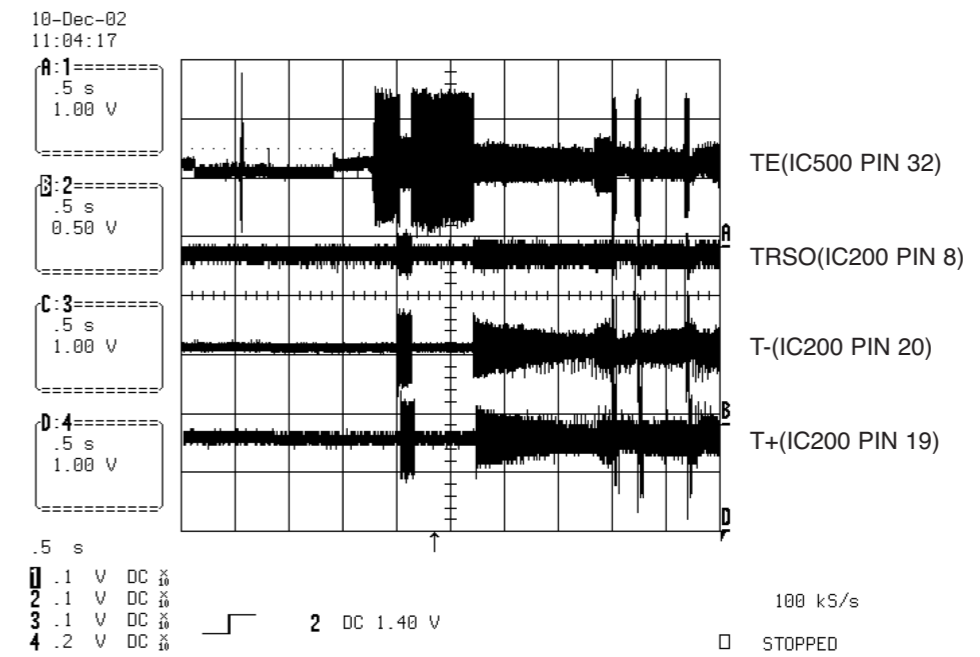

FIG 10-2(CD)

7. RF WAVEFORM

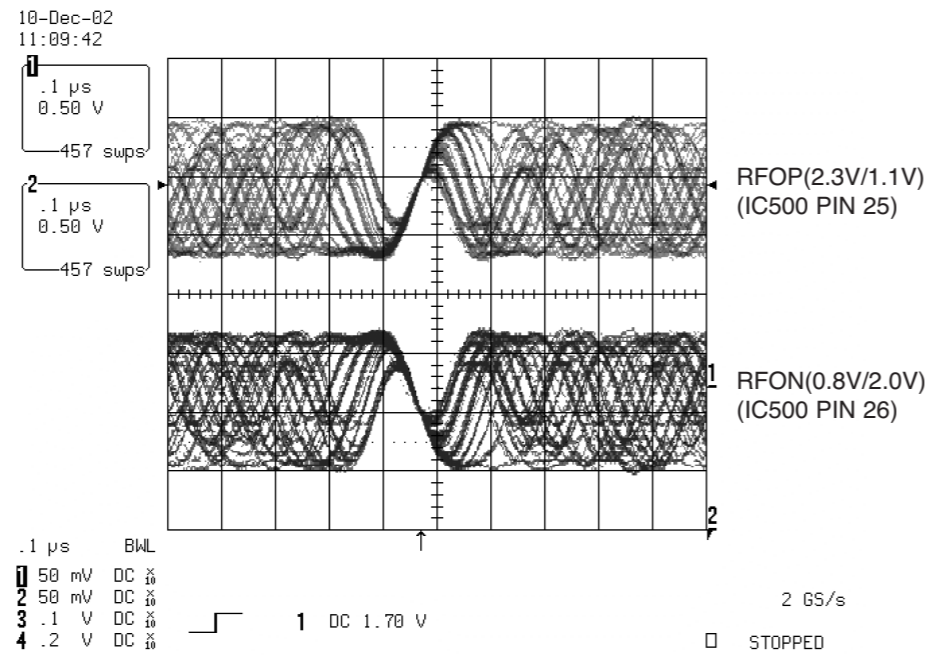

FIG 11-1

8. MT1389 AUDIO OPTICAL AND COAXIAL OUTPUT (ASPDIF)

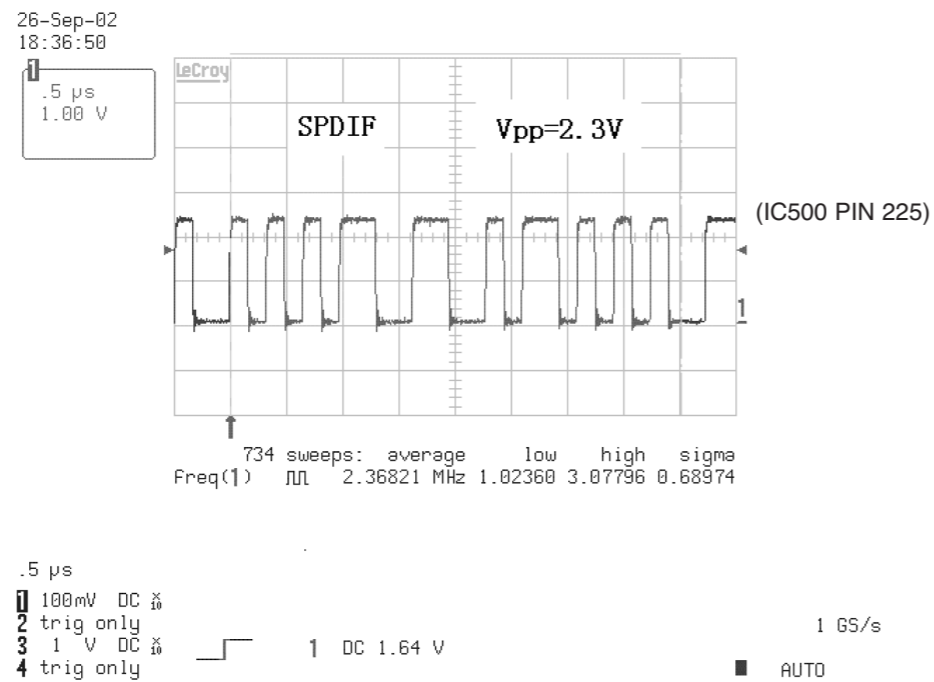

FIG 12-1

9. MT1389 VIDEO OUTPUT WAVEFORM

1) Full colorbar signal(CVBS)

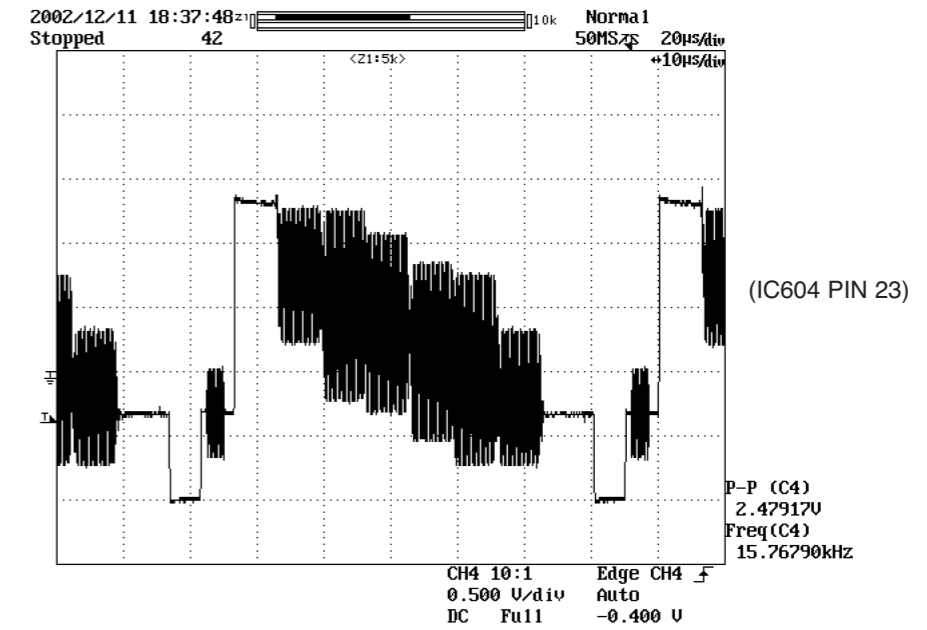

FIG 13-1

2) Y

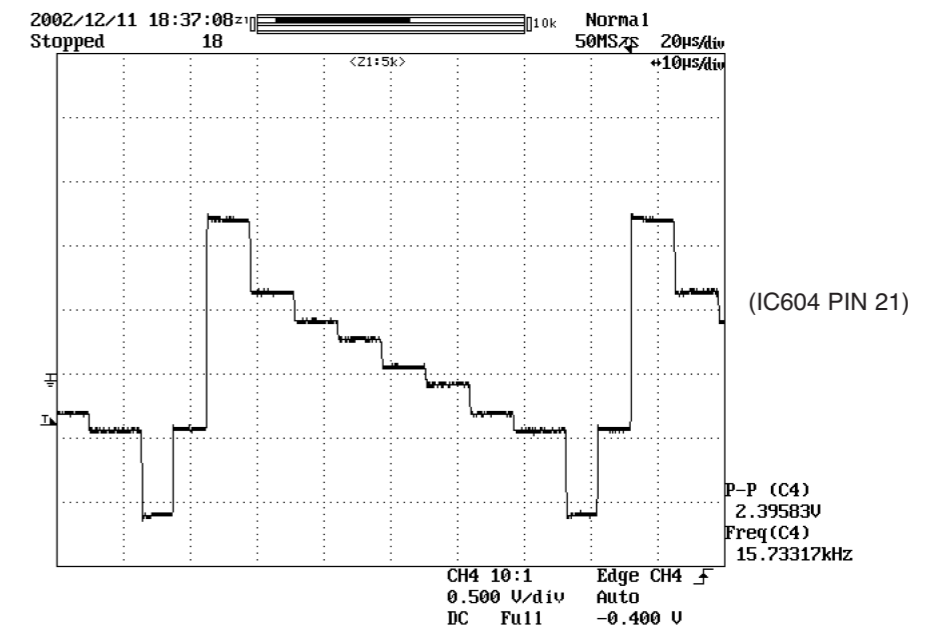

FIG 13-2

3) C

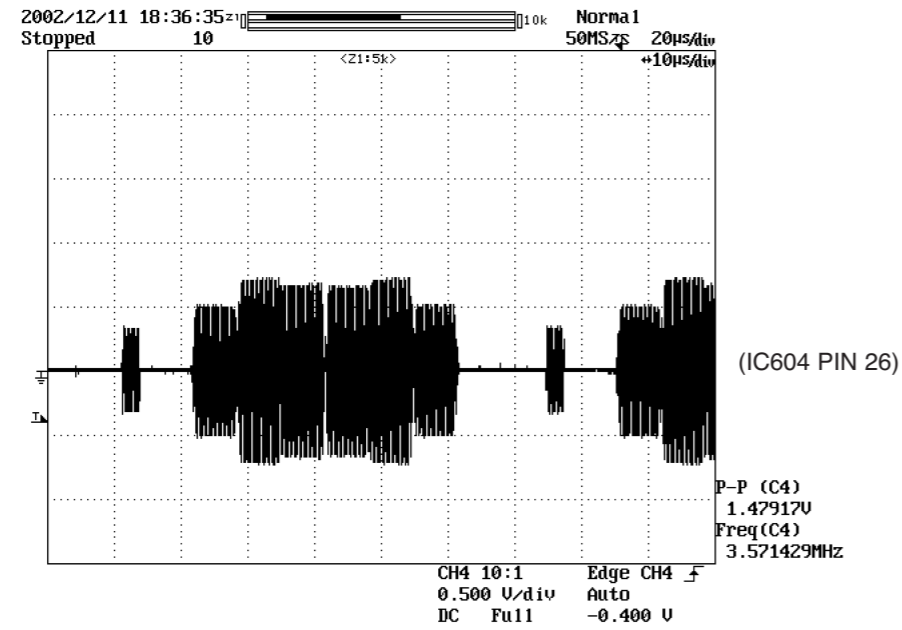

FIG 13-3

10. AUDIO OUTPUT FROM AUDIO DAC

1) Audio L/R

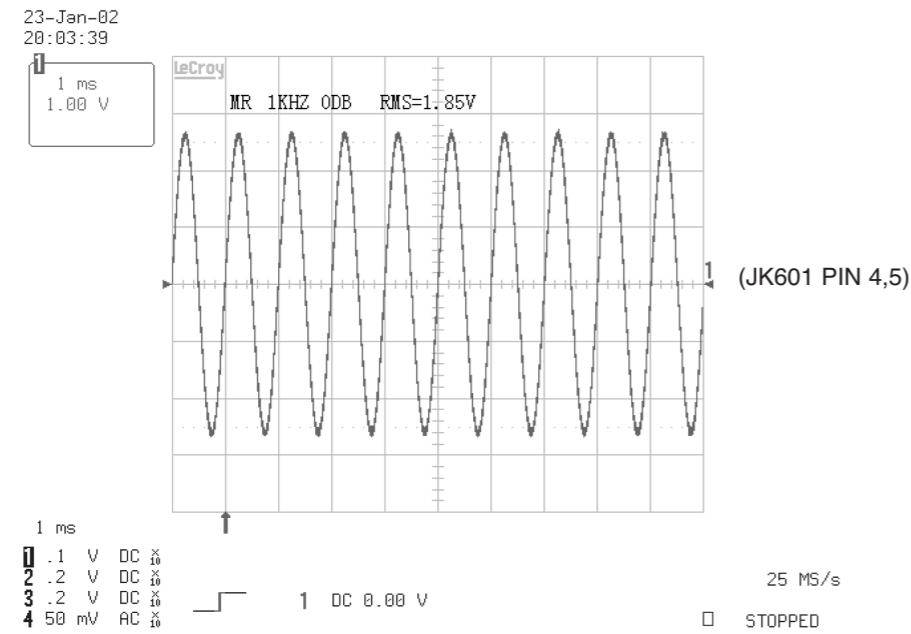

FIG 14-1

2) Audio related Signal

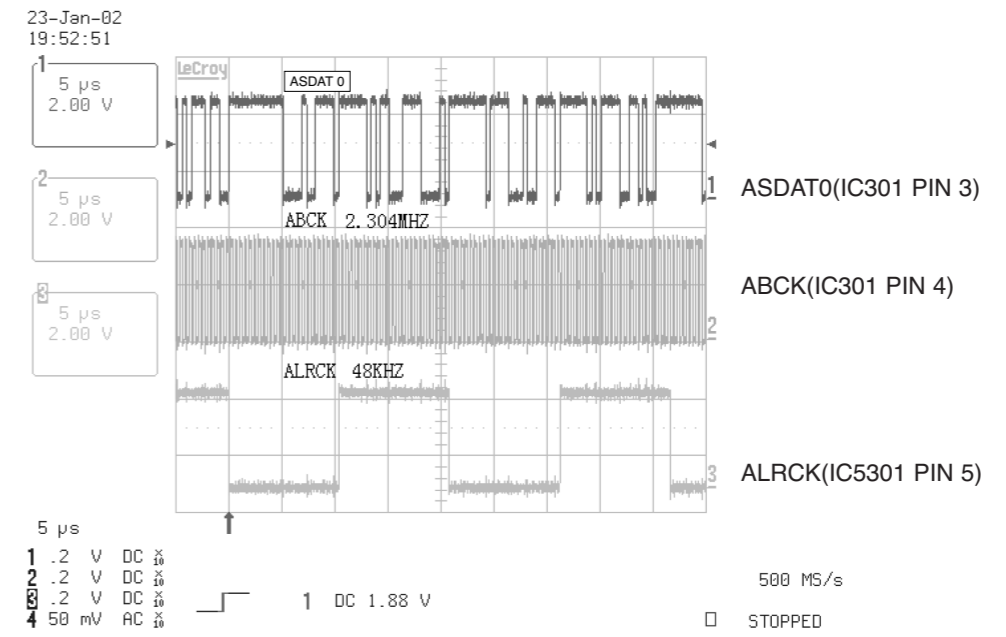

FIG 14-2

CIRCUIT VOLTAGE CHART

MODE PIN NO.	STOP	PLAY
IC 101		
1	15.39	15.33
2	10.23	10.17
3	4.96	4.99
4	0	0
5	10.13	10.08
6	5	4.98
7	0.51	0.52
8	0.1	0.03
IC 102		
1	6.79	6.68
2	3.24	3.32
3	10.23	10.17
4	10.23	10.17
5	10.23	10.12
6	10.23	10.17
7	1.7	1.82
8	12.3	
9	1.35	
10	0.44	
11	2.1	
12	2.49	
13	2.49	
14	2.25	
15	0.68	
16	1.35	
IC 200		
1	0	0
2	0	3.31
3	0	1.65
4	0	0
5	1.4	1.51
6	0.01	0.01
7	1.4	1.41
8	1.4	1.41
9	1.4	1.41
10	1.81	1.21
11	4.72	0.16
12	1.4	1.41
13	1.4	1.41
14	1.4	1.41
15	1.4	1.41
16	1.4	1.41
17	4.97	4.97
18	2.26	3.21
19	2.26	2.3
20	2.32	0
21	0	0
22	4.97	4.36
23	2.32	2.29
24	2.25	2.25
25	4.97	4.36
26	0	0
27	4.97	4.97
28	2.49	2.59

MODE PIN NO.	STOP	PLAY
29	2.71	2.59
30	2.71	2.57
31	2.47	2.57
32	2.53	2.57
33	2.65	2.58
34	0.23	0.33
35	5.97	5.97
36	0	0
37	0.67	2.48
38	0	0
39	0.68	2.48
40	0.66	0
41	0	0
42	4.97	4.97
43	4.97	4.97
44	0	0
45	0	0
46	0	0
47	0	0
48	0	0
IC 301		
1	4.24	4.24
2	4.27	4.27
3	0	1.65
4	2	2
5	1.8	1.8
6	2	2
7	0	0
8	0.34	0
9	3.7	3.7
10	0	0
11	5.9	5.9
12	0	0
13	5.67	5.67
14	2.93	2.93
15	2.94	2.94
16	0	0
17	6.17	6.17
18	2.88	2.88
19	2.6	2.6
20	0	0
IC 302		
1	0	
2	0	
3	0	
4	5.46	
5	0	
6	0	
7	0	
8	6.44	
IC 303		
1	0	0
2	0	0
3	0	0
4	0	0

MODE PIN NO.	STOP	PLAY
5	0	0
6	0	0
7	5.03	5.03
8	0	0
9	0	0
10	0.03	0.03
11	0	0
12	0	0
13	0	0
14	0	0
15	0	0
16	5.97	5.97
IC 304		
1	0	0
2	0	0
3	0	0
4	4.04	3.99
5	0	0
6	0	0
7	0	0
8	4.97	4.96
IC 305		
1	0.012	0.012
2	0.012	0.012
3	0.012	0.012
4	4.06	4
5	0.012	0.012
6	0.013	0.013
7	0.013	0.14
8	4.97	4.96
IC 306		
1	0.68	0.68
2	4.15	4.15
3	7.59	7.59
4	4.2	4.2
5	0.14	0.14
6	3.8	3.8
7	7.76	7.76
8	4.13	4.13
9	3.17	3.17
10	3.17	3.17
11	3.34	3.34
12	3.34	3.34
13	0	0
14	0	0
15	7.62	7.62
16	3.04	3.04
17	3.34	3.34
18	5.94	5.94
19	6.54	6.54
20	3.92	3.92
21	3.55	3.55
22	0	0
23	3.37	3.37
24	3.37	3.37

MODE PIN NO.	STOP	PLAY
25	6.61	6.61
IC 307		
1	0.012	0.012
2	0.012	0.012
3	0.012	0.012
4	4.08	4
5	0.012	0.012
6	0.012	0.012
7	0.012	0.012
8	4.97	4.95
IC 401		
1	0	0
2	2.93	2.93
3	0	0
4	2.99	2.99
5	0	0
6	2.1	2.1
7	4.96	4.96
8	0	0
IC 402		
1	2	2
2	0	0
3	0	0
4	0	0
5	0	0
6	4.99	4.99
7	2	2
8	0	0
IC 500		
1	0	0
2	1.73	0
3	1.73	1.73
4	1.73	1.73
5	1.73	1.73
6	1.75	1.73
7	2.15	1.74
8	2.2	2.21
9	2.18	2.18
10	2.16	0
11	2.14	2.14
12	1.74	1
13	1.04	1
14	1.03	1
15	0.12	1
16	0.13	0
17	0.12	1
18	0.13	2.05
19	2.05	0
20	2.05	0
21	2.05	0
22	2.38	0
23	3.29	0
24	3.3	3.3
25	0.21	1
26	2.34	0

MODE PIN NO.	STOP	PLAY
27	0	0.82
28	2.8	2.8
29	2	0
30	1.4	0
31	1.52	0
32	1.38	0
33	1.38	0
34	2.62	0
35	2.62	2.73
36	2.25	0
37	2.2	2.11
38	1.37	1.36
38	0	0
40	1.4	0
41	1.43	0
42	1.4	141
43	0	0
44	0	0
45	0	0
46	3.3	3.3
47	2.64	0
48	3.32	0
49	0.01	0
50	3.3	0
51	0	0
52	1.76	1.8
53	2.13	0
54	2.14	2.12
55	2.13	1.74
56	1.81	1.34
57	2.12	0
58	1.83	1.52
59	0	1.63
60	0	2.99
61	0	0
62	0	0
63	0	2.05
64	0	0
65	3.3	3.3
66	3.3	3.32
67	1.29	0
68	2.36	0.32
69	0	0.37
70	0.56	0.46
71	0	3.2
72	1.27	1.42
73	3.3	3.3
74	2.23	1.93
75	1.39	0
76	0	0
77	0	0
78	2.06	0
79	0	0
80	3.3	3.3
81	1.2	1.07

MODE PIN NO.	STOP	PLAY
82	0	0.82
83	1.17	0.77
84	0.64	0.54
85	0	0
86	1.44	0.53
87	1.65	1.77
88	1.4	1.53
89	0	0
90	1.21	1.2
91	1.02	1.03
92	0	0
93	2.06	1.93
94	0	0
95	3	2.74
96	3.28	3.25
97	1.8	1.8
98	3	2.7
99	3	2.7
100	2.97	2.67
101	0	2.68
102	3.33	3.32
103	3.33	3.32
104	3	2.7
105	5.18	5.18
106	3.32	3.31
107	2.76	2.75
108	3.3	3.3
109	0	0
110	5.2	5.2
111	2.67	2.92
112	3.14	3.18
113	2.28	1.6
114	0	0
115	1.06	0.85
116	0	0
117	1.04	1.09
118	1.28	0.94
119	0	0
120	1.18	1.65
121	1.36	1.7
122	1.8	1.75
123	1.26	1.51
124	1.23	1.4
125	1.28	1.16
126	0	0.86
127	3.3	3.3
128	2.35	1.28
129	1.8	1.05
130	0	1.1
131	1.39	1.25
132	1.37	1.27
133	1.31	1.3
134	0	0
135	1.33	1.37
136	3.3	3.3

MODE PIN NO.	STOP	PLAY
137	2.63	1.65
138	3.27	3.1
139	3	2.63
140	3.2	3.1
141	3.3	3.3
142	2.9	2.38
143	1.59	1.7
144	0	0
145	1.38	1.55
146	0.07	0
147	0.31	0.78
148	0	0
149	1.51	1.95
150	1.49	1.93
151	1.49	1.62
152	1.8	1.75
153	0	0
154	0	0
155	3.3	3.3
156	1.72	1.72
157	0.92	2.29
158	0	0
159	0	0
160	0	0
161	0	0
162	1.56	1.4
163	0	0
164	2.36	1.54
165	2.32	1.61
166	1.49	1.61
167	3.3	3.3
168	3.25	3.24
169	3.3	3.27
170	0	0
171	0	0
172	0	0
173	1.8	1.8
174	3.33	3.3
175	0	0
176	2.73	2.73
177	0	0
178	3.32	3.32
179	2.75	0
180	0	0
181	0	0
182	3.3	3.3
183	0	0
184	0	0
185	0	0
186	0	0
187	0	0
188	0	0
189	3.3	3.3
190	1.24	1.24
191	1.25	1.24

MODE PIN NO.	STOP	PLAY
192	2.26	2.25
193	0	0
194	0.46	0.47
195	3.3	3.3
196	0.7	0.7
197	0	0
198	3.28	3.29
199	3.3	3.3
200	0.42	0.43
201	0	0
202	0.57	0.38
203	0	0.42
204	3.3	3.3
205	0.25	2.62
206	2.72	2.64
207	2.71	2.63
208	0	0
209	0	0
210	0	0
211	0.1	3.3
212	3.3	3.3
213	1.31	1.66
214	1.67	1.64
215	1.58	1.57
216	0	0
217	0	1.24
218	0	1.1
219	0	0
220	0	0
221	1.76	1.76
222	0	1.24
223	0	0
224	0	0
225	1.66	1.65
226	0	0
227	1.8	1.76
228	3.3	3.3
229	3.3	3.3
230	0.85	0.86
231</		

MODE PIN NO.	STOP	PLAY
51	0.38	1.51
52	0	0
53	0.25	1.18
54	0	0
IC 503		
1	0	0
2	0	0
3	0	0
4	0	0
5	3.31	3.31
6	0	0
7	0	0
8	3.31	3.31
IC 601		
1	0	0
2	0.16	0.15
3	0	0
4	0	0
5	1.93	2.23
6	0	0
7	0.31	0.03
8	0.82	0.02
9	0	0
10	0.12	0.04
11	2.1	1.61
12	0	0
13	0	0
14	0	0
15	0.69	0.48
16	0	0
17	0.08	0
18	10.53	10.48
19	0	0
20	10.43	10.4
21	10.53	10.4
22	0	0.05
23	0	0
24	0	0
IC 701		
1	1.47	1.47
2	4.98	4.98
3	0	0
4	4.34	4.34
5	4.97	4.97
6	0.05	0.05
7	1.48	1.48
8	1.7	1.7
9	0	0
10	0	0
11	0.23	0.23
12	4.52	4.52
13	4.75	4.75
14	4.97	4.97
15	4.56	4.56
16	4.95	4.95

MODE PIN NO.	STOP	PLAY
17	4.96	4.96
18	4.76	4.76
19	4.95	4.95
20	1.82	1.82
21	1.94	1.94
22	1.13	1.13
23	1.83	1.83
24	1.84	1.84
25	4.9	4.9
26	3	3
27	2.56	2.56
28	0	0
29	4.96	4.96
30	2.04	2.04
31	4.91	4.91
32	0	0
33	0	0
34	0	0
35	0	0
36	4.98	4.98
37	0	0
38	4.97	4.97
39	1.94	1.94
40	1.92	1.92
41	5.11	5.11
42	5.12	5.12
43	4.98	4.98
44	4.98	4.98
IC 702		
1	4.94	4.93
2	0	0
3	4.83	0
IC 703		
1	0	0
2	3.1	2.98
3	3.3	3.29
4	3.3	3.3
5	3.3	0
6	0	0
7	0	0
8	0	0
9	3.27	3.2
10	0	0
11	4.97	4.85
12	0	0
13	0	0
14	0	0
15	4.97	4.95
16	4.97	0
17	0	4.42
18	4.34	4.57
19	0	0
20	4.97	4.96
IC 704		
1	4.3	4

MODE PIN NO.	STOP	PLAY
2	0.12	0.03
3	0	0
4	4.99	4.98
5	4.99	4.98
IC 801		
1	2.41	2.41
2	2.6	2.6
3	2.48	2.48
4	1.04	1.04
5	2.75	2.75
6	3.62	3.62
7	3.52	3.52
8	1.68	1.68
9	1.93	1.93
10	1.93	1.93
11	1.87	1.87
12	2.69	2.69
13	0	0
14	4.22	4.22
15	2.58	2.58
16	3.18	3.18
17	0	0
18	2.5	2.5
19	2.49	2.49
20	2.76	2.76
21	2.5	2.5
22	2.81	2.81
23	3.19	3.19
24	2.5	2.5
25	2.81	2.81
26	2.36	2.36
27	2.44	2.44
28	2.31	2.31
29	2.17	2.17
30	2.16	2.16
31	2.3	2.3
32	2.5	2.5
33	2.3	2.3
34	4.63	4.63
35	0.59	0.59
36	2.24	2.24
37	2.17	2.17
38	3.6	3.6
39	0	0
40	2.46	2.46
41	2.49	2.49
42	2.5	2.5
43	4.96	4.96
44	1.25	1.25
45	2.6	2.6
46	2.94	2.94
47	3.24	3.24
48	2.78	2.78
IC 802		
1	2.48	2.48

MODE PIN NO.	STOP	PLAY
2	4.95	4.95
3	4.25	4.25
4	1.01	1.01
5	4.91	4.91
6	2.53	2.53
7	0	0
8	0.06	0.06
9	4.87	4.87
10	0.03	0.03
11	0.02	0.02
12	0.05	0.05
13	0.01	0.01
14	0.03	0.03
15	2.5	2.5
16	0.3	0.3
17	0.3	0.3
18	2.4	2.4
19	2.25	2.25
20	4.98	4.98
21	4.99	4.99
22	4.98	4.98
23	0	0
24	5.03	5.03
25	2.33	2.33
26	2.38	2.38
27	4.95	4.95
28	0.52	0.52
29	4.89	4.89
30	4.93	4.93
31	0	0
32	4.88	4.88
33	0.1	0.1
34	4.64	4.64
35	0.6	0.6
36	0	0
37	0.1	0.1
38	0.1	0.1
39	0.1	0.1
40	5	5
41	0.38	0.38
42	4.89	4.89
43	0	0
44	2.5	2.5
45	0.1	0.1
46	2.45	2.45
47	2.45	2.45
48	5.04	5.04
IC 803		
1	2.51	2.51
2	2.49	2.49
3	2.5	2.5
4	2.5	2.5
5	2.49	2.49
6	0	0
7	0	0

MODE PIN NO.	STOP	PLAY
8	0	0
9	4.96	4.96
10	4.96	4.96
11	4.96	4.96
12	2.48	2.48
13	2.5	2.5
14	2.5	2.5
15	2.51	2.51
16	7.39	7.39
IC 804		
1	2.5	2.5
2	2.5	2.5
3	0	0
4	2.39	2.39
5	4.98	4.98
IC 805		
1	0.14	0.14
2	0.08	0.08
3	0.06	0.06
4	9.82	9.82
5	0.14	0.14
6	0.15	0.15
7	0.14	0.14
8	4.97	4.97
IC 8 F1		
1	1.72	1.72
2	0.94	0.94
3	1.28	1.28
4	1.23	1.23
5	2.07	2.07
6	1.6	1.6
7	9.07	9.07
8	0	0
9	10.16	10.16
10	1.6	1.6
11	0	0
12	238	238
13	2.35	2.35
14	2.37	2.37
15	0.05	0.05
16	2.47	2.47
IC 8 F2		
1	0.14	0.14
2	9.08	9.08
3	9.33	9.33
4	0.14	0.14
5	0	0
6	0	0
IC 8 F3		
1	4.97	4.97
2	4.97	4.97
3	0	0
4	0.08	0.08
5	9.84	9.84
6	0	0

MODE PIN NO.	STOP	PLAY
7	0	0
8	9.85	9.85

	STOP	PLAY	STOP	PLAY	STOP	PLAY	STOP	PLAY	STOP	PLAY
TR	Q317		Q319		Q305		Q316		Q807	
Emitter	0.72	0	0	0	3.53	0	4.96	4.96	0	0
Collector	0	0	0	5.09	3.33	0	4.97	4.97	0	0
Base	0.7	0.83	0.68	0	0	5.04	1.12	1.12	4.9	4.9
TR	Q308		Q327		Q328		Q204		Q408	
Emitter	4.94	4.94	0.72	0.72	0.72	0.72	3.3	3.3	0	0
Collector	4.96	4.96	0	0	0	0	0	0	0	0
Base	1.37	1.37	0.7	0.7	0.7	0.7	0	0	0	0
TR	Q202		Q201		Q203		Q704		Q320	
Emitter	0	0	0	0	3.26	3.26	0.5	0.5	0	5.1
Collector	0.72	5	3.27	3.27	0.3	0.3	0	0	0.7	0
Base	0	0.7	0	0	3.3	3.3	5	5	0	5.05
TR	Q705		Q706		Q703		Q803		Q323	
Emitter	5	5	5	5	0.5	0.5	0	0	0	0
Collector	5.7	5.7	5	5	0	0	2.86	2.86	0.72	0.72
Base	0	0	0	0	5	5	4.98	4.98	0	0
TR	Q814		Q801		Q802		Q419		Q811	
Emitter	1.32	1.32	0	0	2	2	0	0	0	0
Collector	0.64	0.64	0	0	2.2	2.2	0	0	0	0
Base	0	0	2.8	2.8	4.97	4.97	1.95	1.95	4.99	4.99
TR	Q602		Q603		Q404		Q902		Q430	
Emitter	0	0	0	0	3.4	3.4	0.38	0.38	2.02	2.02
Collector	0	0	0	0	3.35	3.35	0.38	0.38	3.33	3.33
Base	0	0	0	0	0	0	0.09	0.09	0	0
TR	Q409		Q418		Q105		Q315		Q325	
Emitter	0	0	0	0	0	0	0	4.34	0	0
Collector	0	0	0	0	0.87	0.87	0	2.42	0.7	0.13
Base	0.827	0.827	1.948	1.948	0	0	5.07	3.64	0	0
TR	Q901		Q104		Q314		Q318		Q324	
Emitter	0	0	0	0	0	0	0	0	0	0
Collector	0.1	0.1	0	0	0.72	0.19	0.72	0.72	0.72	0.72
Base	0.18	0.18	2.49	2.49	0	0	0	0	0	0
TR	Q8F1		Q415		Q326		Q806		Q329	
Emitter	0.15	0.15	0	0	0	0	5.02	5.02	0	0
Collector	10.2	10.2	0	0	0.72	0	4.3	4.3	0.72	0
Base	0	0	2.27	2.27	0	0.74	4.92	4.92	0	0.16
TR	Q330									
Emitter	0	0								
Collector	0.72	0								
Base	0	0								

	STOP	PLAY	STOP	PLAY	STOP	PLAY	STOP	PLAY	STOP	PLAY
TR	Q102		Q103		Q101		Q601		Q810	
1	0	0	0	0	10.2	10.2	10.55	10.55	2.23	2.23
2	10.6	10.6	4.98	4.98	10.2	10.2	10.55	10.55	2.23	2.23
3	10.6	10.6	4.98	4.98	10.2	10.2	10.55	10.55	1.63	1.63
4	11	11	5	5	9.55	9.55	10.54	10.54	1.07	1.07
5	3.41	3.41	3.3	3.3	0	0	0	0	0.33	0.33
6	0	0	0	0	0	0	0	0	1.76	1.76
7					0	0	0	0		
8					0	0	0	0		

PRINTED CIRCUIT DIAGRAMS

1. MAIN P.C. BOARD

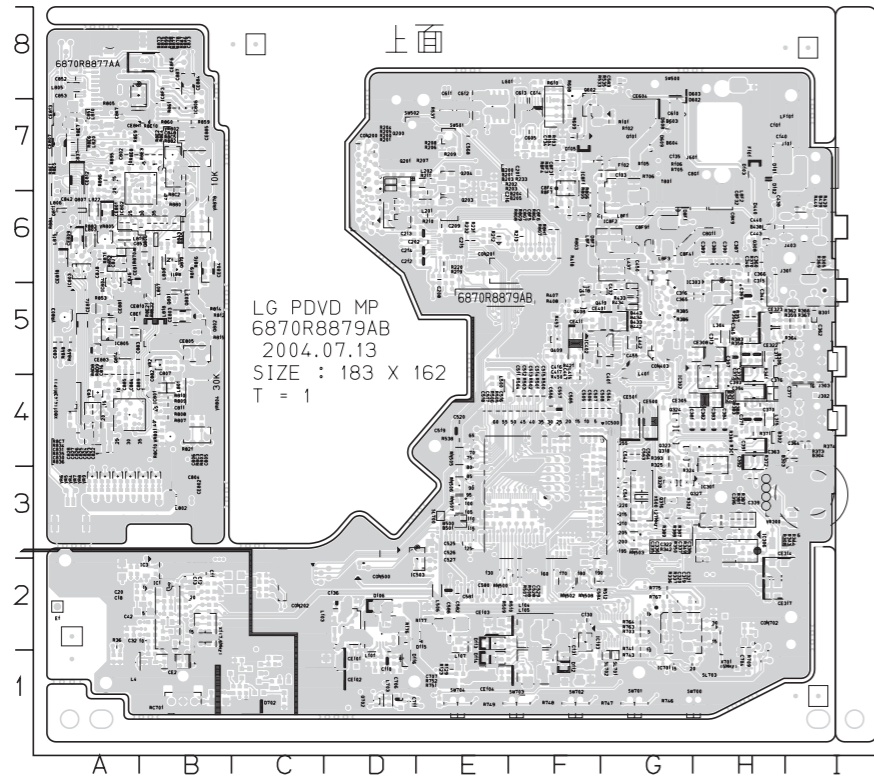

LOCATION GUIDE

B200	D7	C321	H2	C508	G4	C826	A4	CE802	B3	IC301	H4	L201	E6	Q803	B5	R369	I6	R703	G2	R8A5	B6	SW702	F1	TP157	F1	TP5	B2	TP720	E1
B201	C7	C322	H3	C511	F4	C827	A4	CE803	B5	IC302	H4	L202	E6	Q806	B6	R370	H6	R705	G7	R8A6	B6	SW703	F1	TP170	G7	TP515	B7	TP721	F1
B203	D6	C335	H3	C512	F4	C828	A4	CE804	B6	IC303	H5	L304	H5	Q807	A6	R371	H4	R706	G7	R8A7	B6	SW704	E1	TP171	F7	TP519	F4	TP722	G1
B204	D6	C336	H3	C513	F4	C830	A4	CE805	B5	IC306	H3	L315	H4	Q810	B6	R372	H4	R709	H2	R8A8	A5	T13	B5	TP172	E1	TP531	F4	TP723	G1
B205	D6	C337	H3	C514	F4	C831	A4	CE807	A7	IC402	F5	L317	H5	Q811	A6	R373	I4	R741	G2	R8A9	A5	T14	B5	TP243	D7	TP535	E4	TP747	B1
B301	I5	C338	H3	C515	F4	C837	A7	CE809	A6	IC508	F3	L401	H1	Q814	A5	R374	I4	R743	G1	R8C10	B4	T18	A4	TP244	D7	TP536	E4	TP752	G2
B302	H4	C339	H3	C516	F4	C842	A6	CE810	A5	IC503	F3	L401	H1	R101	G7	R383	H5	R746	G1	R8C2	B7	T19	B1	TP251	D6	TP571	E3	TP753	G2
B303	H4	C344	H5	C517	E4	C848	B7	CE811	B6	IC701	G2	L415	F5	R102	G7	R387	G3	R747	G1	R8C3	B3	T2	B4	TP252	D6	TP571	E3	TP754	G2
B304	I4	C345	H5	C518	E4	C851	A7	CE812	A7	IC801	A4	L437	G6	R103	F7	R388	G3	R748	F1	R8C5	B7	T21	B4	TP253	E7	TP573	E3	TP786	G2
B305	I6	C346	H6	C519	E4	C852	A8	CE813	A7	IC802	B7	L442	G5	R104	F7	R389	G3	R749	E1	R8C7	A4	T22	B4	TP256	E6	TP590	E2	TP787	G2
B306	H5	C360	H6	C520	E4	C853	A8	CE814	A6	IC803	A6	L500	F4	R105	G7	R393	G4	R751	E1	R8D8	A4	T23	B5	TP263	E6	TP591	E2	TP791	G2
B307	H4	C362	I5	C525	E3	C857	A6	CE818	A6	IC804	A5	L506	E2	R106	G7	R341	H5	R752	E1	R8D9	A4	T24	A3	TP264	E7	TP593	E2	TP792	G2
B308	I4	C363	H4	C526	E3	C882	B4	CE881	A5	IC805	A5	L601	E7	R123	E1	R342	H4	R763	G2	R8E1	A7	T27	B3	TP27	B2	TP595	E2	TP802	F7
B433	G5	C364	I4	C527	E2	C883	A5	CE883	A5	IC806	B7	L703	D1	R129	E1	R343	I4	R764	G2	R8E10	B7	T28	B4	TP28	B2	TP608	E2	TP804	F6
B434	G5	C365	H5	C528	F2	C884	A4	CE884	B8	IC8F1	F7	L801	B4	R176	D2	R344	I4	R767	G2	R8E2	B7	T30	B4	TP29	B2	TP609	F4	TP807	F6
B438	H6	C366	H6	C529	F2	C885	A4	CE885	B7	IC8F2	F7	L802	B3	R177	E2	R349	H4	R775	G2	R8E21	A5	T33	A3	TP302	G3	TP618	G8	TP808	F6
B439	I6	C369	H5	C541	G3	C887	B8	CE8F6	B8	IC8F3	A8	L803	A6	R200	D7	R381	H3	R803	B3	R8E22	A5	T35	A4	TP307	G3	TP619	G3	TP809	H1
B442	G5	C370	H4	C542	G3	C889	A5	CE8H1	A7	I11	B7	L805	A8	R201	D7	R383	H4	R805	A7	R8E3	B7	T37	A4	TP312	G4	TP620	I6	TP811	F6
B434	G5	C365	H5	C528	F2	C884	A4	CE884	B8	IC8F1	F7	L801	B4	R176	D2	R344	I4	R767	G2	R8E2	B7	T30	B4	TP29	B2	TP609	F4	TP807	F6
B438	H6	C366	H6	C529	F2	C885	A4	CE885	B7	IC8F2	F7	L802	B3	R177	E2	R349	H4	R775	G2	R8E21	A5	T33	A3	TP302	G3	TP618	G8	TP808	F6
B439	I6	C369	H5	C541	G3	C887	B8	CE8F6	B8	IC8F3	A8	L803	A6	R200	D7	R381	H3	R803	B3	R8E22	A5	T35	A4	TP307	G3	TP619	G3	TP809	H1
B442	G5	C370	H4	C542	G3	C889	A5	CE8H1	A7	I11	B7	L805	A8	R201	D7	R383	H4	R805	A7	R8E3	B7	T37	A4	TP312	G4	TP620	I6	TP811	F6
B443	G5	C371	H4	C556	F4	C8E1	A5	CON200	D7	IT102	A5	L806	A7	R202	D6	R385	H5	R807	B4	R8E4	B7	T44	A4	TP313	H4	TP622	F2	TP812	G7
B500	E3	C372	H5	C557	F4	C8F31	F7	CON201	F6	IT122	B6	L807	B5	R203	D6	R386	H5	R808	B4	R8E5	A7	T45	A5	TP314	H4	TP630	E4	TP813	G7
B501	E3	C373	H5	C563	G4	C8F32	H6	CON202	C2	IT124	B6	L808	B6	R204	D7	R387	H3	R809	B4	R8E6	A7	T46	A3	TP317	G5	TP631	E4	TP814	G7
B603	G7	C376	H4	C564	G4	C8F4	F6	CON403	D5	IT130	B7	L810	A7	R205	D7	R388	H4	R810	B4	R8E7	A7	T48	A4	TP318	G4	TP639	E3	TP816	G6
B604	G7	C377	I4	C568	E7	C8F41	G6	CON500	D2	IT131	B7	L815	A6	R206	E7	R3C1	H4	R811	B6	R8E8	A7	T49	A5	TP319	H4	TP641	B6	TP817	G7
C101	H7	C381	G4	C580	E2	C8F5	F6	CON702	H1	IT137	A7	L818	B5	R207	E7	R407	F5	R812	B5	R8E9	B7	T53	B5	TP320	H5	TP641	E3	VR2	B5
C103	G7	C382	H4	C581	E2	C8F6	F6	D101	H7	IT138	A7	L819	A6	R208	E7	R408	F5	R814	B5	R8F3	F7	T58	A4	TP331	H5	TP648	G4	VR3	A4
C11	B2	C383	H4	C582	E2	C8F91	G6	D102	H7	IT139	A7	L820	A7	R209	E7	R418	F6	R815	B5	R8F4	F7	T6	B5	TP338	H5	TP652	G2	VR300	I3
C110	D1	C384	H4	C583	G8	C8G1	F7	D103	H7	IT140	A7	L822	A6	R210	E6	R421	F5	R816	B6	R8F7	F6	T62	A5	TP34	B2	TP653	G2	VR4	A3
C12	B2	C387	H6	C584	F2	C8H1	H6	D105	F7	IT141	A7	L821	B6	R211	E6	R433	F5	R819	B6	R8G3	F6	T64	A5	TP342	H5	TP654	G3	VR5	A3
C13	B2	C388	H6	C585	F4	C8H2	H6	D106	D2	IT142	A7	L822	B6	R212	E6	R434	F5	R821	B4	R8G4	F6	T69	A3	TP344	I5	TP655	E2	VR6	A3
C130	F2	C389	H6	C586	E2	C8J3	B6	D112	F1	IT145	A7	L8F3	G6	R213	F6	R439	I6	R834	A4	R8G5	F6	T7	B6	TP348	I5	TP656	E8	VR7	A3
C131	F2	C390	H6	C605	F7	C8J6	A5	D113	E2	IT146	A7	L8F4	G6	R213	F6	R439	I6	R835	A4	R8G6	F6	T7	A3	TP353	I6	TP657	F7	VR8	B3
C134	F7	C391	H4	C610	E7	C8J7	A6	D114	E1	IT150	A5	LF101	H7	R220	E6	R450	F4	R836	A4	R8G7	F6	T75	A4	TP354	H5	TP658	F8	VR801	B4
C135	G7	C392	H4	C611	E7	C8J8	A6	D115	E2	IT152	A6	Q101	F7	R231	E6	R453	F5	R852	A6	R8G8	F6	T76	B3	TP363	I4	TP667	F7	VR802	B7
C136	D2	C393	H4	C612	E7	C8K7	A7	D116	D1	IT158	A6	Q200	F7	R232	E6	R500	F4	R853	A5	R8G9	F6	T77	B3	TP371	H2	TP669	F7	VR803	A5
C140	H7	C394	H4	C613	F7	C8K9	H6	D440	H6	IT160	G7	Q201	D7	R233	D6	R501	F4	R859	B7	R8H1	F6	T78	A3	TP379	H3	TP673	G7	VR804	B4
C18	A2	C396	H3	C614	F7	CE101	D1	D602	G7	I13	A5	Q203	E6	R302	G3	R502	F4	R860	B7	RC701	B1	T79	B3	TP381	H3	TP674	G7	VR805	A6
C20	A2	C397	H5	C704	H2	CE102	D1	D603	G8	I14	A5	Q204	E7	R324	A4	R503	F4	R861	B7	RN500	E2	T80	B3	TP385	H3	TP675	G7	VR806	B6
C201	D7	C401	H5	C706	D1	CE103	E2	D608	G7	IT6	A5	Q308	H6	R325	G4	R504	F4	R870	A6	RN502	E2	T801	G6	TP394	H2	TP676	D3	VR9	B3
C202	E6	C416	F5	C707	E1	CE104	E1	D609	G7	I17	A5	Q316	G3	R336	H2	R505	E4	R871	A6	RN503	G3	T81	A3	TP397	H2	TP677	D3	X1	B2
C208	E6	C417	F5	C711	D2	CE105	H1	D612	C1	I196	A6	Q318	G4	R337	H2	R506	E2	R872	A6	RN505	G3	T9	B1	TP398	H2	TP678	D3	X20	G3
C209	E6	C42	A2	C712	A2	CE106	H1	D801	A6	IT98	A6	Q323	G3	R338	H2	R507	F2	R873	A6	RN506	E3	TP100	H7	TP342	I4	TP679	D3	X701	G2
C212	E6	C432	G5	C804	B3	CE308	H5	D8F1	G6	J101	I7	Q324	A4	R349	H3	R508	E2	R877	B6	RN507	E3	TP104	F7	TP380	H4	TP697	F2	X801	A4
C213	E6	C438	H6	C805	B3	CE314	H2	D8F3	G6	J301	I5	Q327	G3	R350	H3	R509	E2	R878	B6	RN508	F2	TP106	G7	TP384	H4	TP700	H2		
C214	E6	C440	H6	C806	B3	CE317	H2	E1	A2	J302	I4	Q328	G3	R356	H5	R510	F2	R880	B6	SL700	E3	TP107	F7	TP41	B2	TP701	H2		
C215	E6	C443	H6	C807	B4	CE322	H5	F101	H7	J303	I5	Q408	F5	R357	H6	R512	G2	R882	B7	SL701	G1	TP108	G7	TP416	I6	TP702	H2		
C216	D6	C447	H5	C808	A5	CE323	H6	E102	G7	J403	I6	Q409	F5	R358	H6	R513	G2	R883	A6	SL702	G2	TP109	F7	TP417	I6	TP703	H2		
C313	H5	C450	G6	C811	B4	CE401	G5	GT601	G7	J601	G7	Q418	F6	R359	I5	R535	G8	R884	A6	SL703	H1	TP140	F2	TP423	G5	TP704	G2		
C315	H6	C455	G5	C816	A4	CE411	F5	GT602	G7	L101	D2	Q419	F5	R36	A2	R537	E7	R895	A7	SW500	G8	TP141	F2	TP425	G5	TP706	H2		
C316	H5	C504	G4	C822	B4	CE500	G4	GT603	G7	L103	D2	Q602	F7	R362	I5	R538	E4	R896	A7	SW501	E7	TP142	F1	TP434	F6	TP707	H1		
C319	H2	C505	F4	C823	A4	CE501	G4	IC1	B2	L104	F2	Q702	D1	R364	I5	R608	F7	R898	B6	SW502	D7	TP151	D1	TP437	F6	TP708	E3		
C32	A2	C506	F4	C824	A4	CE604	G7	IC103	F2	L105	F1	Q801	B5	R366	I5	R609	F7	R899	A6	SW700	H1	TP154	F1	TP438	F5	TP716	G2		
C320	H2	C507	F4	C825	A4	CE801	A6	IC3	B2	L107	E2	Q802	B5	R367	I5	R610	F7	R8A3	B6	SW701	G1	TP156	F2	TP49	B6	TP719			

2. KEY P. C. BOARD

