



SERVICE MANUAL

MODELS : DVX286/DV286/DV286K

# DVD-VIDEO PLAYER

## SERVICE MANUAL

**MODELS : DVX286/DV286/DV286K**

**CAUTION**

BEFORE SERVICING THE UNIT, READ THE "SAFETY PRECAUTIONS" IN THIS MANUAL.

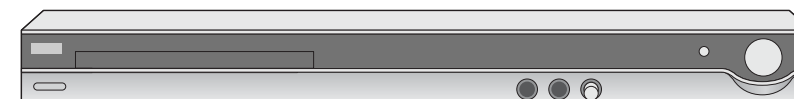

## **CONTENTS**

**SECTION 1.....SUMMARY**

**SECTION 2.....CABINET & MAIN CHASSIS**

**SECTION 3.....ELECTRICAL**

**SECTION 4.....MECHANISM (DP-11)**

**SECTION 5.....REPLACEMENT PARTS LIST**

# SECTION 1

## SUMMARY

### CONTENTS

<b>PRODUCT SAFETY SERVICING GUIDELINES FOR DVD PRODUCTS .....</b>	<b>1-3</b>
<b>SERVICING PRECAUTIONS .....</b>	<b>1-4</b>
• GENERAL SERVICING PRECAUTIONS	
• INSULATION CHECKING PRODEDURE	
• ELECTROSTATICALLY SENSITIVE (ES) DEVICES	
<b>SERVICE INFORMATION FOR EEPROM.....</b>	<b>1-5</b>
<b>SPECIFICATIONS .....</b>	<b>1-6</b>

# PRODUCT SAFETY SERVICING GUIDELINES FOR DVD PRODUCTS

**CAUTION :** DO NOT ATTEMPT TO MODIFY THIS PRODUCT IN ANY WAY, NEVER PERFORM CUSTOMIZED INSTALLATIONS WITHOUT MANUFACTURER'S APPROVAL. UNAUTHORIZED MODIFICATIONS WILL NOT ONLY VOID THE WARRANTY, BUT MAY LEAD TO YOUR BEING LIABLE FOR ANY RESULTING PROPERTY DAMAGE OR USER INJURY.

SERVICE WORK SHOULD BE PERFORMED ONLY AFTER YOU ARE THOROUGHLY FAMILIAR WITH ALL OF THE FOLLOWING SAFETY CHECKS AND SERVICING GUIDELINES. TO DO OTHERWISE, INCREASES THE RISK OF POTENTIAL HAZARDS AND INJURY TO THE USER.

WHILE SERVICING, USE AN ISOLATION TRANSFORMER FOR PROTECTION FROM A.C. LINE SHOCK.

## SAFETY CHECKS

AFTER THE ORIGINAL SERVICE PROBLEM HAS BEEN CORRECTED, A CHECK SHOULD BE MADE OF THE FOLLOWING.

### SUBJECT : FIRE & SHOCK HAZARD

1. BE SURE THAT ALL COMPONENTS ARE POSITIONED IN SUCH A WAY AS TO AVOID POSSIBILITY OF ADJACENT COMPONENT SHORTS. THIS IS ESPECIALLY IMPORTANT ON THOSE MODULES WHICH ARE TRANSPORTED TO AND FROM THE REPAIR SHOP.
2. NEVER RELEASE A REPAIR UNLESS ALL PROTECTIVE DEVICES SUCH AS INSULATORS, BARRIERS, COVERS, SHIELDS, STRAIN RELIEFS, POWER SUPPLY CORDS, AND OTHER HARDWARE HAVE BEEN REINSTALLED PER ORIGINAL DESIGN. BE SURE THAT THE SAFETY PURPOSE OF THE POLARIZED LINE PLUG HAS NOT BEEN DEFEATED.
3. SOLDERING MUST BE INSPECTED TO DISCOVER POSSIBLE COLD SOLDER JOINTS, SOLDER SPLASHES OR SHARP SOLDER POINTS. BE CERTAIN TO REMOVE ALL LOOSE FOREIGN PARTICLES.
4. CHECK FOR PHYSICAL EVIDENCE OF DAMAGE OR DETERIORATION TO PARTS AND COMPONENTS. FOR FRAYED LEADS, DAMAGED INSULATION (INCLUDING A.C. CORD). AND REPLACE IF NECESSARY FOLLOW ORIGINAL LAYOUT, LEAD LENGTH AND DRESS.
5. NO LEAD OR COMPONENT SHOULD TOUCH A RECEIVING TUBE OR A RESISTOR RATED AT 1 WATT OR MORE. LEAD TENSION AROUND PROTRUDING METAL SURFACES MUST BE AVOIDED.
6. ALL CRITICAL COMPONENTS SUCH AS FUSES, FLAMEPROOF RESISTORS, CAPACITORS, ETC. MUST BE REPLACED WITH EXACT FACTORY TYPES, DO NOT USE REPLACEMENT COMPONENTS OTHER THAN THOSE SPECIFIED OR MAKE UNRECOMMENDED CIRCUIT MODIFICATIONS.
7. AFTER RE-ASSEMBLY OF THE SET ALWAYS PERFORM AN A.C. LEAKAGE TEST ON ALL EXPOSED METALLIC PARTS OF THE CABINET, (THE CHANNEL SELECTOR KNOB, ANTENNA TERMINALS, HANDLE AND SCREWS) TO BE SURE THE SET IS SAFE TO OPERATE WITHOUT DANGER OF ELECTRICAL SHOCK. DO NOT USE A LINE ISOLATION TRANSFORMER DURING THIS TEST USE AN A.C. VOLTMETER, HAVING 5000 OHMS PER VOLT OR MORE SENSITIVITY, IN THE FOLLOWING MANNER; CONNECT A 1500 OHM 10 WATT RESISTOR, PARALLELED BY A .15 MFD. 150.V A.C TYPE CAPACITOR BETWEEN A KNOWN GOOD EARTH GROUND (WATER PIPE, CONDUIT, ETC.) AND THE EXPOSED METALLIC PARTS, ONE AT A TIME. MEASURE THE A.C. VOLTAGE ACROSS THE COMBINATION OF 1500 OHM RESISTOR AND .15 MFD CAPACITOR. REVERSE THE A.C. PLUG AND REPEAT A.C. VOLTAGE MEASUREMENTS FOR EACH EXPOSED METALLIC PART.  
VOLTAGE MEASURED MUST NOT EXCEED 75 VOLTS R.M.S. THIS CORRESPONDS TO 0.5 MILLIAMPS A.C ANY VALUE EXCEEDING THIS LIMIT CONSTITUTES A POTENTIAL SHOCK HAZARD AND MUST BE CORRECTED IMMEDIATELY.

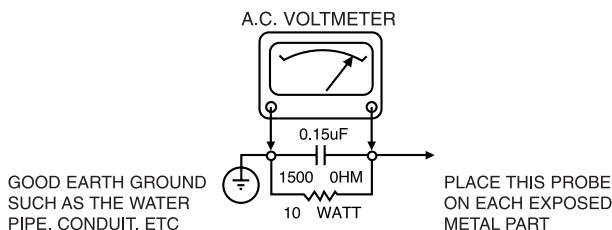

### SUBJECT : GRAPHIC SYMBOLS



THE LIGHTNING FLASH WITH APROWHEAD SYMBOL, WITHIN AN EQUILATERAL TRIANGLE, IS INTENDED TO ALERT THE SERVICE PERSONNEL TO THE PRESENCE OF UNINSULATED "DANGEROUS VOLTAGE" THAT MAY BE OF SUFFICIENT MAGNITUDE TO CONSTITUTE A RISK OF ELECTRIC SHOCK.



THE EXCLAMATION POINT WITHIN AN EQUILATERAL TRIANGLE IS INTENDED TO ALERT THE SERVICE PERSONNEL TO THE PRESENCE OF IMPORTANT SAFETY INFORMATION IN SERVICE LITERATURE.

### SUBJECT : X-RADIATION

1. BE SURE PROCEDURES AND INSTRUCTIONS TO ALL SERVICE PERSONNEL COVER THE SUBJECT OF X-RADIATION. THE ONLY POTENTIAL SOURCE OF X-RAYS IN CURRENT T.V. RECEIVERS IS THE PICTURE TUBE. HOWEVER, THIS TUBE DOES NOT EMIT X-RAYS WHEN THE HIGH VOLTAGE IS AT THE FACTORY SPECIFIED LEVEL. THE PROPER VALUE IS GIVEN IN THE APPLICABLE SCHEMATIC. OPERATION AT HIGHER VOLTAGES MAY CAUSE A FAILURE OF THE PICTURE TUBE OR HIGH VOLTAGE SUPPLY AND, UNDER CERTAIN CIRCUMSTANCES, MAY PRODUCE RADIATION IN EXCESS OF DESIRABLE LEVELS.
2. ONLY FACTORY SPECIFIED C.R.T. ANODE CONNECTORS MUST BE USED. DEGAUSSING SHIELDS ALSO SERVE AS X-RAY SHIELD IN COLOR SETS, ALWAYS RE-INSTALL THEM.
3. IT IS ESSENTIAL THAT SERVICE PERSONNEL HAVE AVAILABLE AN ACCURATE AND RELIABLE HIGH VOLTAGE METER. THE CALIBRATION OF THE METER SHOULD BE CHECKED PERIODICALLY AGAINST A REFERENCE STANDARD, SUCH AS THE ONE AVAILABLE AT YOUR DISTRIBUTOR.
4. WHEN THE HIGH VOLTAGE CIRCUITRY IS OPERATING PROPERLY THERE IS NO POSSIBILITY OF AN X-RADIATION PROBLEM. EVERY TIME A COLOR CHASSIS IS SERVICED. THE BRIGHTNESS SHOULD BE RUN UP AND DOWN WHILE MONITORING THE HIGH VOLTAGE WITH A METER TO BE CERTAIN THAT THE HIGH VOLTAGE DOES NOT EXCEED THE SPECIFIED VALUE AND THAT IT IS REGULATING CORRECTLY, WE SUGGEST THAT YOU AND YOUR SERVICE ORGANIZATION REVIEW TEST PROCEDURES SO THAT VOLTAGE REGULATION IS ALWAYS CHECKED AS A STANDARD SERVICING PROCEDURE. AND THAT THE HIGH VOLTAGE READING BE RECORDED ON EACH CUSTOMER'S INVOICE.
5. WHEN TROUBLESHOOTING AND MAKING TEST MEASUREMENTS IN A PRODUCT WITH A PROBLEM OF EXCESSIVE HIGH VOLTAGE, AVOID BEING UNNECESSARILY CLOSE TO THE PICTURE TUBE AND THE HIGH VOLTAGE SUPPLY. DO NOT OPERATE THE PRODUCT LONGER THAN IS NECESSARY TO LOCATE THE CAUSE OF EXCESSIVE VOLTAGE.
6. REFER TO HV. B+ AND SHUTDOWN ADJUSTMENT PROCEDURES DESCRIBED IN THE APPROPRIATE SCHEMATIC AND DIAGRAMS (WHERE USED).

### SUBJECT : IMPLOSION

1. ALL DIRECT VIEWED PICTURE TUBES ARE EQUIPPED WITH AN INTEGRAL IMPLOSION PROTECTION SYSTEM, BUT CARE SHOULD BE TAKEN TO AVOID DAMAGE DURING INSTALLATION, AVOID SCRATCHING THE TUBE. IF SCRATCHED REPLACE IT.
2. USE ONLY RECOMMENDED FACTORY REPLACEMENT TUBES.

### SUBJECT : TIPS ON PROPER INSTALLATION

1. NEVER INSTALL ANY PRODUCT IN A CLOSED-IN RECESS, CUBBYHOLE OR CLOSELY FITTING SHELF SPACE. OVER OR CLOSE TO HEAT DUCT, OR IN THE PATH OF HEATED AIR FLOW.
2. AVOID CONDITIONS OF HIGH HUMIDITY SUCH AS: OUTDOOR PATIO INSTALLATIONS WHERE DEW IS A FACTOR, NEAR STEAM RADIATORS WHERE STEAM LEAKAGE IS A FACTOR, ETC.
3. AVOID PLACEMENT WHERE DRAPERIES MAY OBSTRUCT REAR VENTING. THE CUSTOMER SHOULD ALSO AVOID THE USE OF DECORATIVE SCARVES OR OTHER COVERINGS WHICH MIGHT OBSTRUCT VENTILATION.
4. WALL AND SHELF MOUNTED INSTALLATIONS USING A COMMERCIAL MOUNTING KIT. MUST FOLLOW THE FACTORY APPROVED MOUNTING INSTRUCTIONS A PRODUCT MOUNTED TO A SHELF OR PLATFORM MUST RETAIN ITS ORIGINAL FEET (OR THE EQUIVALENT THICKNESS IN SPACERS) TO PROVIDE ADEQUATE AIR FLOW ACROSS THE BOTTOM, BOLTS OR SCREWS USED FOR FASTENERS MUST NOT TOUCH ANY PARTS OR WIRING. PERFORM LEAKAGE TEST ON CUSTOMIZED INSTALLATIONS.
5. CAUTION CUSTOMERS AGAINST THE MOUNTING OF A PRODUCT ON SLOPING SHELF OR A TILTED POSITION, UNLESS THE PRODUCT IS PROPERLY SECURED.
6. A PRODUCT ON A ROLL-ABOUT CART SHOULD BE STABLE ON ITS MOUNTING TO THE CART. CAUTION THE CUSTOMER ON THE HAZARDS OF TRYING TO ROLL A CART WITH SMALL CASTERS ACROSS THRESHOLDS OR DEEP PILE CARPETS.
7. CAUTION CUSTOMERS AGAINST THE USE OF A CART OR STAND WHICH HAS NOT BEEN LISTED BY UNDERWRITERS LABORATORIES, INC. FOR USE WITH THEIR SPECIFIC MODEL OF TELEVISION RECEIVER OR GENERICALLY APPROVED FOR USE WITH T.V.'S OF THE SAME OR LARGER SCREEN SIZE.
8. CAUTION CUSTOMERS AGAINST THE USE OF EXTENSION CORDS, EXPLAIN THAT A FOREST OF EXTENSIONS SPROUTING FROM A SINGLE OUTLET CAN LEAD TO DISASTROUS CONSEQUENCES TO HOME AND FAMILY.

# SERVICING PRECAUTIONS

**CAUTION** : Before servicing the DVD covered by this service data and its supplements and addends, read and follow the *SAFETY PRECAUTIONS*. **NOTE** : if unforeseen circumstances create conflict between the following servicing precautions and any of the safety precautions in this publications, always follow the safety precautions.

Remembers Safety First:

## General Servicing Precautions

1. Always unplug the DVD AC power cord from the AC power source before:

- (1) Removing or reinstalling any component, circuit board, module, or any other assembly.
- (2) Disconnection or reconnecting any internal electrical plug or other electrical connection.
- (3) Connecting a test substitute in parallel with an electrolytic capacitor.

**Caution** : A wrong part substitution or incorrect polarity installation of electrolytic capacitors may result in an explosion hazard.

2. Do not spray chemicals on or near this DVD or any of its assemblies.

3. Unless specified otherwise in this service data, clean electrical contacts by applying an appropriate contact cleaning solution to the contacts with a pipe cleaner, cotton-tipped swab, or comparable soft applicator. Unless specified otherwise in this service data, lubrication of contacts is not required.

4. Do not defeat any plug/socket B+ voltage interlocks with which instruments covered by this service manual might be equipped.

5. Do not apply AC power to this DVD and/or any of its electrical assemblies unless all solid-state device heat sinks are correctly installed.

6. Always connect test instrument ground lead to the appropriate ground before connection the test instrument positive lead. Always remove the test instrument ground lead last.

## Insulation Checking Procedure

Disconnect the attachment plug from the AC outlet and turn the power on. Connect an insulation resistance meter(500V) to the blades of the attachment plug. The insulation resistance between each blade of the attachment plug and accessible conductive parts (Note 1) should be more than 1Mohm.

**Note 1** : Accessible Conductive Parts including Metal panels, Input terminals, Earphone jacks, etc.

## Electrostatically Sensitive (ES) Devices

Some semiconductor (solid state) devices can be damaged easily by static electricity. Such components commonly are called Electrostatically Sensitive (ES) Devices. Examples of typical ES devices are integrated circuits and some field effect transistors and semiconductor chip components. The following techniques should be used to help reduce the incidence of component damage caused by static electricity.

1. Immediately before handling any semiconductor component or semiconductor-equipped assembly, drain off any electrostatic charge on your body by touching a known earth ground.

Alternatively, obtain and wear a commercially available discharging wrist strap device, which should be removed for potential shock reasons prior to applying power to the unit under test.

2. After removing an electrical assembly equipped with ES devices, place the assembly on a conductive surface such as aluminum foil, to prevent electrostatic charge buildup or exposure of the assembly.

3. Use only a grounded-tip soldering iron to solder or unsolder ES devices.

4. Use only an anti-static solder removal device. Some solder removal devices not classified a "anti-static" can generate electrical charges sufficient to damage ES devices.

5. Do not use freon-propelled chemicals. These can generate electrical charge sufficient to damage ES devices.

6. Do not remove a replacement ES device from its protective package until immediately before you are ready to install it. (Most replacement ES devices are packaged with leads electrically shorted together by conductive foam, aluminum foil, or comparable conductive material).

7. Immediately before removing the protective material from the leads of a replacement ES device, touch the protective material to the chassis or circuit assembly into which the device will be installed.

**Caution** : Be sure no power is applied to the chassis or circuit, and observe all other safety precautions.

8. Minimize bodily motions when handling unpackaged replacement ES devices. (Normally harmless motion such as the brushing together of your clothes fabric or the lifting of your foot from a carpeted floor can generate static electricity sufficient to damage an ES device.)

# SERVICE INFORMATION FOR EEPROM

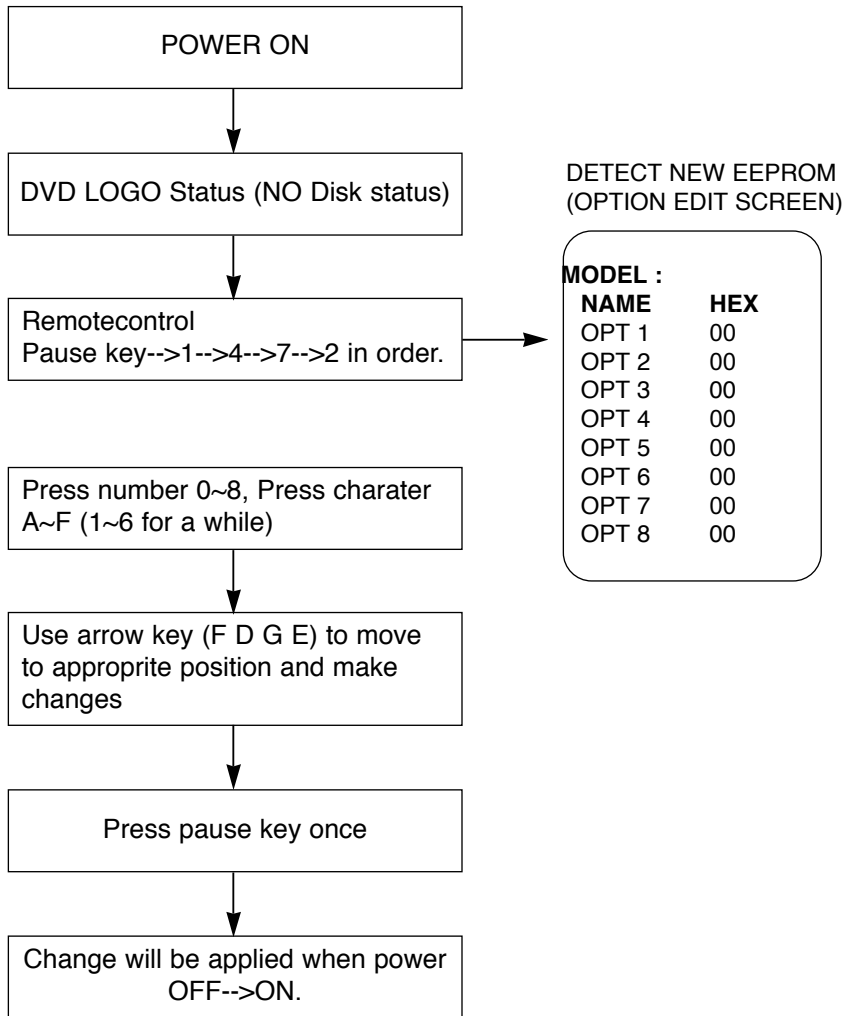

# SPECIFICATIONS

## • GENERAL

Power requirements :	AC 200-240V , 50/60Hz
Power consumption :	8W
Dimensions (Approx.) :	430 x 35 x 202mm (17 x 1.4 x 7.9inches) (W x H x D) without foot
Net Weight (Approx.) :	1.9kg (4.2lbs)
Operating temperature :	5°C to 35°C (41°F to 95°F)
Operating humidity :	5% to 90%

## • OUTPUTS

VIDEO OUT :	1.0V (p-p), 75Ω, sync negative, RCA jack x 1 / <span style="border: 1px dashed black; padding: 2px;">Scart (to TV) <sup>★</sup></span>
S-VIDEO OUT :	(Y) 1.0 V (p-p), 75Ω, negative sync, Mini DIN 4-pin x 1 (C) 0.3 V (p-p), 75Ω
COMPONENT VIDEO OUT :	(Y) 1.0 V (p-p), 75Ω, negative sync, RCA jack x 1 (Pb)/(Pr) 0.7 V (p-p), 75Ω, RCA jack x 2
AUDIO OUT :	2.0Vrms (1 KHz, 0 dB), 600Ω, RCA jack (L, R) x 1 / <span style="border: 1px dashed black; padding: 2px;">Scart (to TV) <sup>★</sup></span>
DIGITAL OUT (COAXIAL) :	0.5V (p-p), 75Ω, RCA jack x 1

★ Scart model only

## • SYSTEM

Laser :	Semiconductor laser, wavelength 650 nm
Signal system :	PAL/NTSC
Frequency response :	DVD (PCM 96kHz) : 8Hz to 44kHz DVD (PCM 48 kHz) : 8Hz to 22kHz CD : 8Hz to 20kHz
Signal-to-noise ratio :	More than 90dB (ANALOG OUT connectors only)
Harmonic distortion :	Less than 0.02%
Dynamic range :	More than 95dB (DVD/CD)
Accessories :	Video cable (1), Audio cable (1), Remote control (1), Batteries (2)

**Note** : Design and specifications are subject to change without prior notice.

**SECTION 2**  
**CABINET & MAIN CHASSIS**

**CONTENTS**

**EXPLODED VIEWS.....2-2**

- 1. CABINET AND MAIN FRAME SECTION .....2-2**
- 2. DECK MECHANISM SECTION (DP-11) .....2-3**
- 3. PACKING ACCESSORY SECTION .....2-4**



# EXPLODED VIEWS

## 1. CABINET AND MAIN FRAME SECTION

5

4

3

2

1

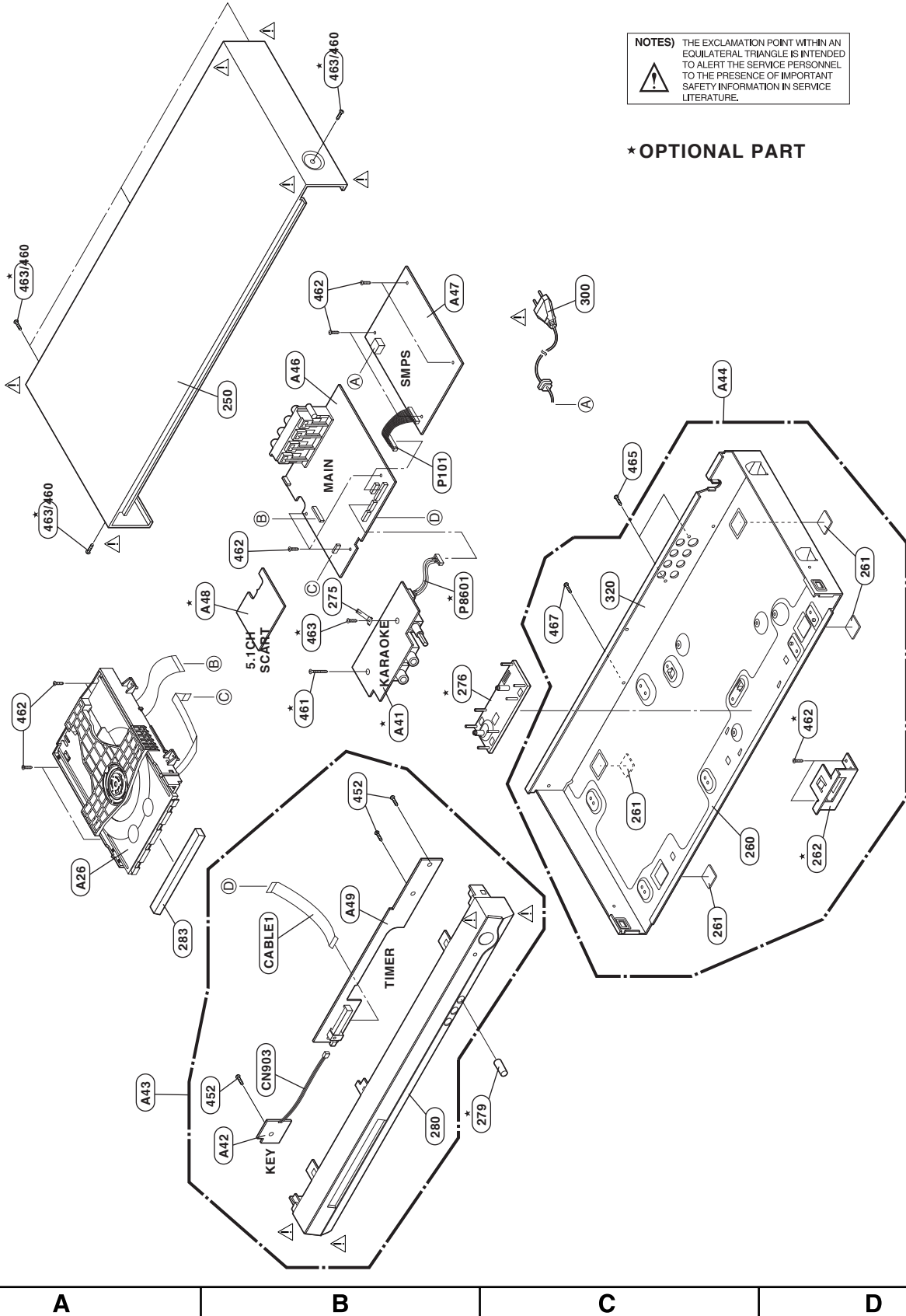

**NOTES)** THE EXCLAMATION POINT WITHIN AN EQUILATERAL TRIANGLE IS INTENDED TO ALERT THE SERVICE PERSONNEL TO THE PRESENCE OF IMPORTANT SAFETY INFORMATION IN SERVICE LITERATURE.

**\*OPTIONAL PART**

A B C D

## 2. DECK MECHANISM SECTION (DP-11)

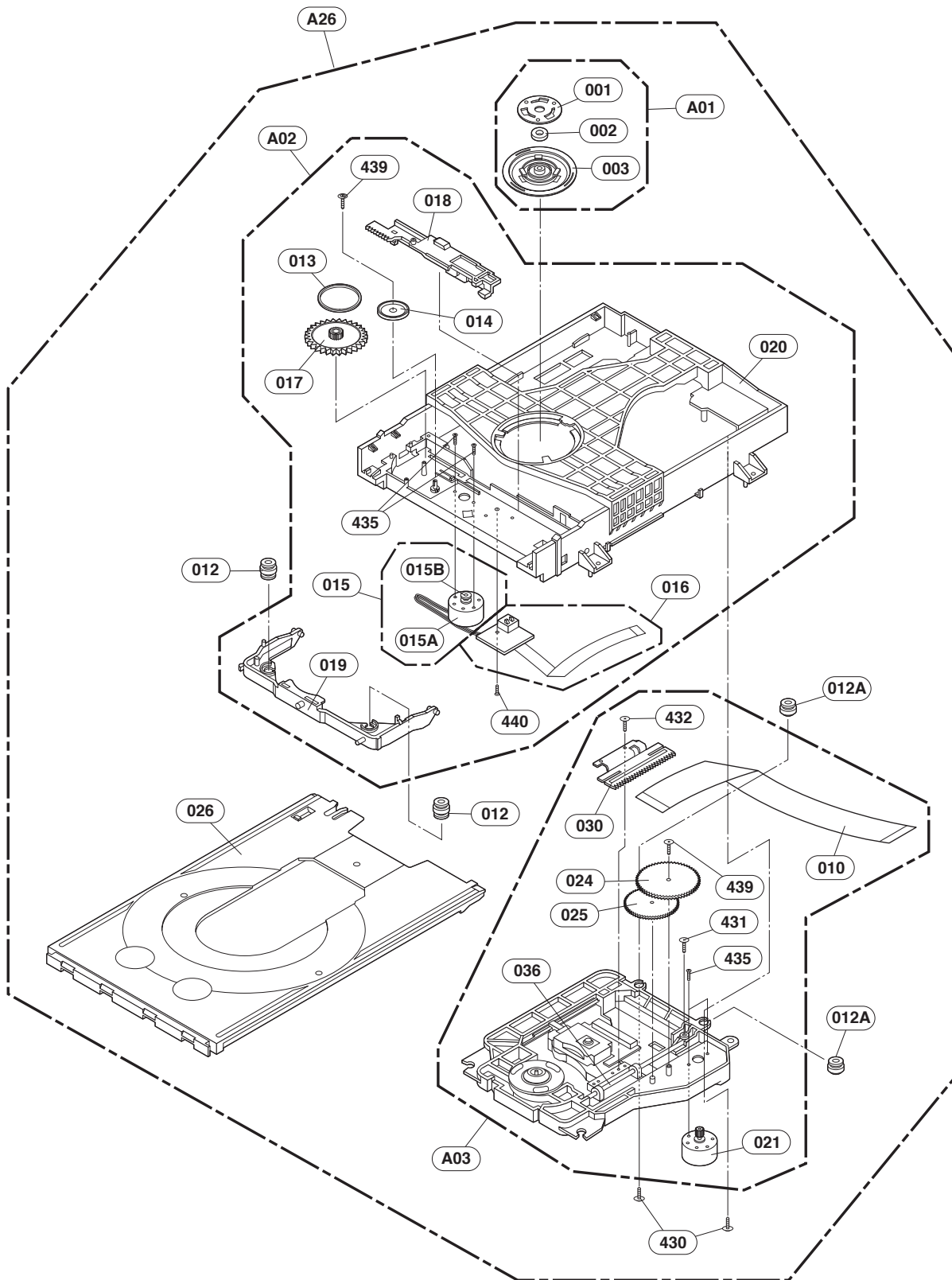

### 3. PACKING ACCESSORY SECTION

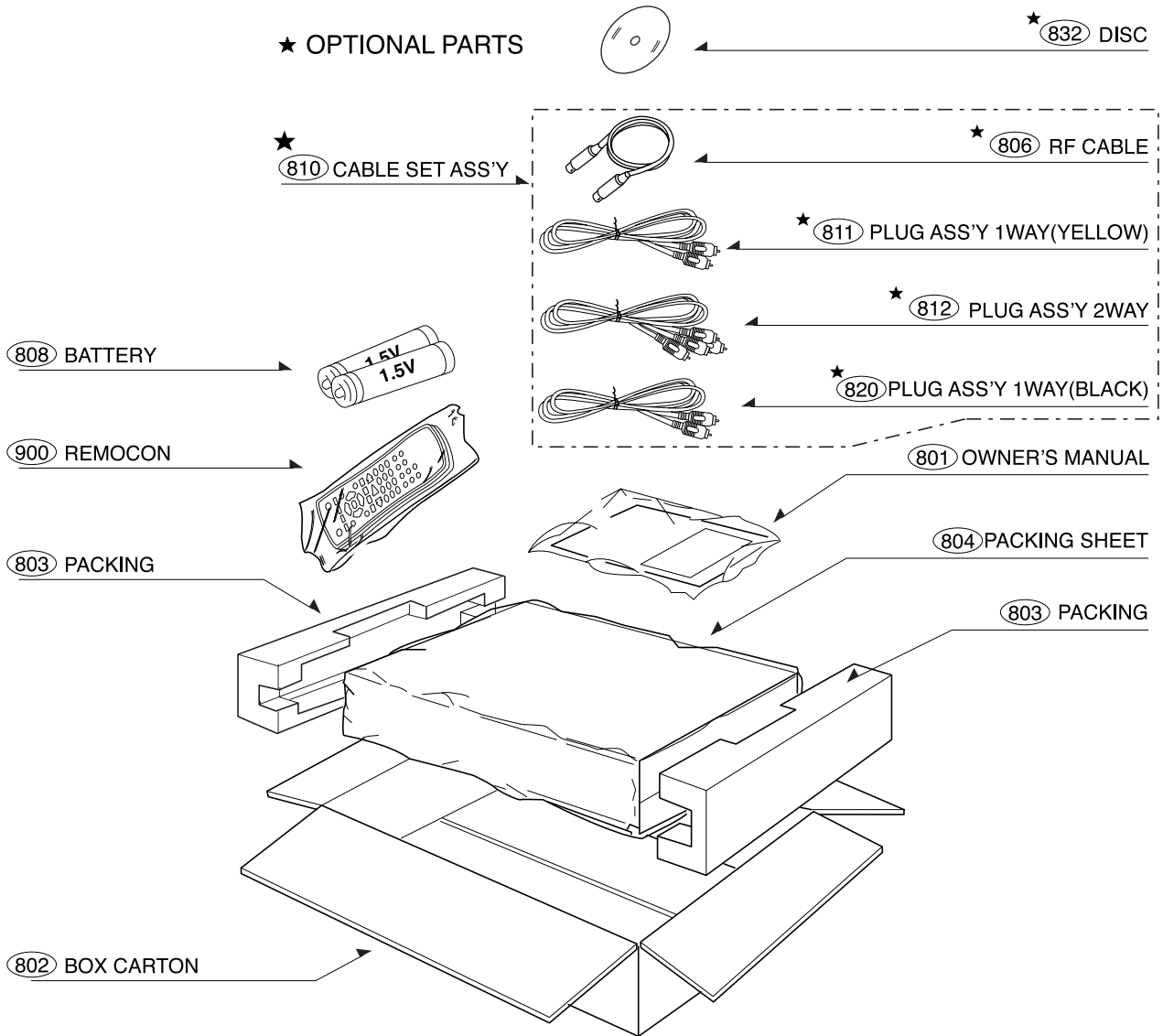

# SECTION 3

## ELECTRICAL

### CONTENTS

<b>ELECTRICAL TROUBLESHOOTING GUIDE</b> .....	<b>3-2</b>
1. POWER CHECK FLOW .....	3-2
2. SYSTEM OPERATION FLOW .....	3-3
3. SYSTEM TEST FLOW .....	3-4
<b>DETAILS AND WAVEFORMS ON SYSTEM TEST AND DEBUGGIBG</b> .....	<b>3-10</b>
1. SYSTEM 27MHZ CLOCK, RESET, FLASH R/W SIGNAL .....	3-10
2. SDRAM CLOCK .....	3-12
3. TRAY OPEN/CLOSE SIGNAL .....	3-12
4. SLED CONTROL RELATED SIGNAL (NO DISC CONDITION) .....	3-13
5. LENS CONTROL RELATED SIGNAL (NO DISC CONDITION) .....	3-13
6. LASER POWER CONTROL RELATED SIGNAL (NO DISC CONDITION) .....	3-14
7. DISC TYPE JUDGEMENT WAVEFORM .....	3-14
8. FOCUS ON WAVEFORM .....	3-16
9. SPINDLE CONTROL WAVEFORM (NO DISC CONDITION) .....	3-17
10. TRACKING CONTROL RELATED SIGNAL (SYSTEM CHECKING) .....	3-18
11. MT1389E AUDIO OPTICAL AND COAXIAL OUTPUT (SPDIF) .....	3-19
12. MT1389E VIDEO OUTPUT WAVEFORM .....	3-19
13. AUDIO OUTPUT FROM MT1389E .....	3-20
<b>CONNECTOR PICTURE</b> .....	<b>3-21</b>
1. FULL CONNECTOR PICTURE .....	3-21
2. CN201 CONNECTOR PICTURE .....	3-22
3. CN202 CONNECTOR PICTURE .....	3-22
4. CN601 CONNECTOR PICTURE .....	3-23
5. CN602 CONNECTOR PICTURE .....	3-23
6. CN605 CONNECTOR PICTURE .....	3-24
7. CN703 CONNECTOR PICTURE .....	3-24
8. CN704 CONNECTOR PICTURE .....	3-25
9. P101 CONNECTOR PICTURE .....	3-25
<b>BLOCK DIAGRAMS</b> .....	<b>3-26</b>
1. OVERALL BLOCK DIAGRAM .....	3-26
2. POWER SUPPLY BLOCK DIAGRAM .....	3-27
3. SERVO BLOCK DIAGRAM .....	3-28
4. MPEG & MEMORY BLOCK DIAGRAM .....	3-29
5. VIDEO BLOCK DIAGRAM .....	3-30
6. AUDIO BLOCK DIAGRAM .....	3-31
<b>CIRCUIT DIAGRAMS</b> .....	<b>3-33</b>
1. POWER (SMPS) CIRCUIT DIAGRAM .....	3-33
2. SYSTEM (MPEG) CIRCUIT DIAGRAM .....	3-35
3. SERVO CIRCUIT DIAGRAM .....	3-37
4. AV/JACK CIRCUIT DIAGRAM .....	3-39
5. KARAOKE & USB CIRCUIT DIAGRAM (8 & 9 TOOL) .....	3-41
6. TIMER/KEY CIRCUIT DIAGRAM (4 & 7 TOOL) .....	3-43
7. TIMER/KEY CIRCUIT DIAGRAM (5 TOOL) .....	3-45
8. TIMER/KEY CIRCUIT DIAGRAM (8 TOOL) .....	3-47
9. TIMER/KEY CIRCUIT DIAGRAM (9 TOOL) .....	3-49
• CIRCUIT VOLTAGE CHART .....	3-51
<b>PRINTED CIRCUIT DIAGRAMS</b> .....	<b>3-53</b>
1. MAIN P.C.BOARD .....	3-53
2. KEY P.C.BOARD .....	3-55
3. TIMER P.C.BOARD .....	3-55
4. KARAOKE P.C.BOARD (KARAOKE MODEL ONLY) .....	3-56
5. SMPS P.C.BOARD .....	3-57
6. SUB SCART (OPTIONAL PART) .....	3-58
7. SUB 5.1CH (OPTIONAL PART) .....	3-58

# ELECTRICAL TROUBLESHOOTING GUIDE

## 1. POWER CHECK FLOW

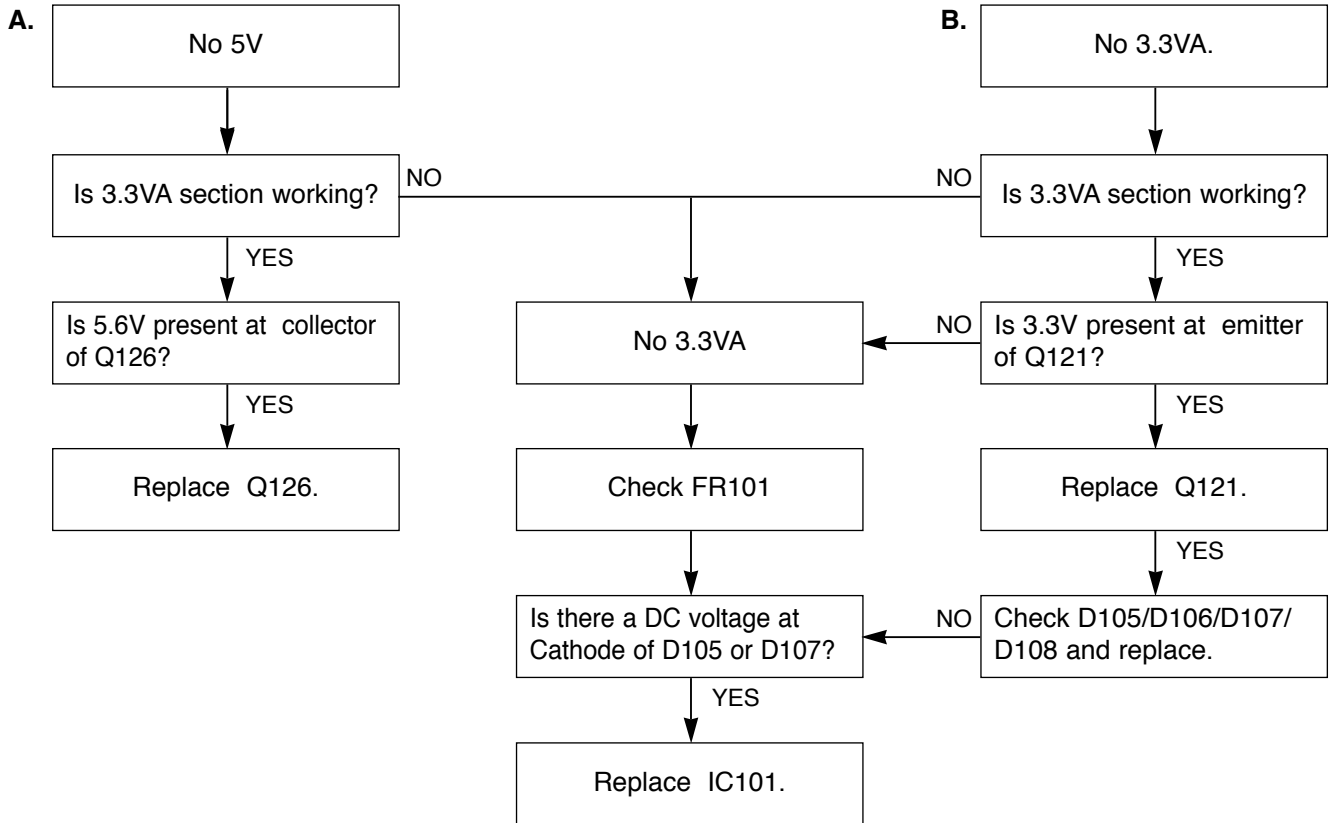

## 2. SYSTEM OPERATION FLOW

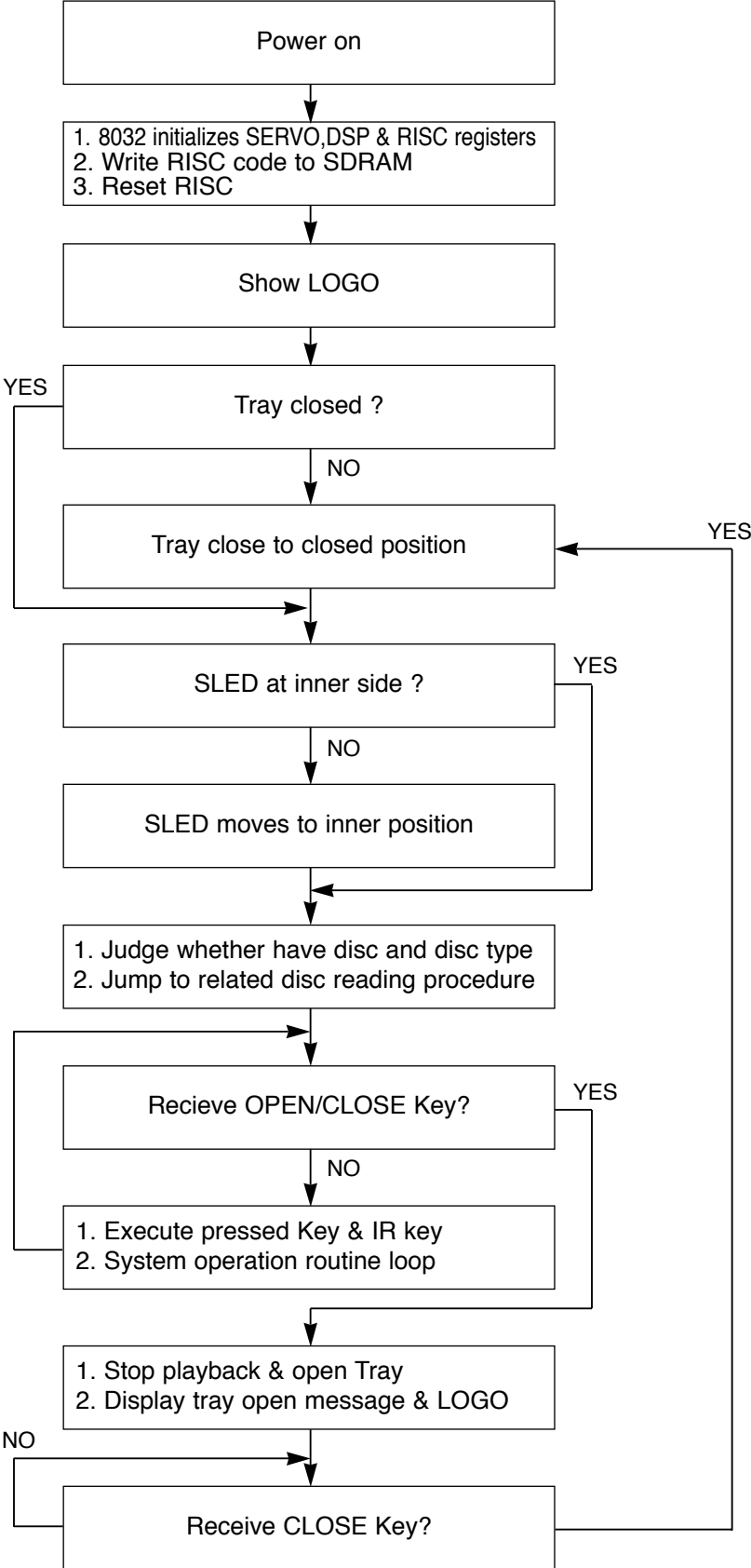

### 3. SYSTEM TEST FLOW

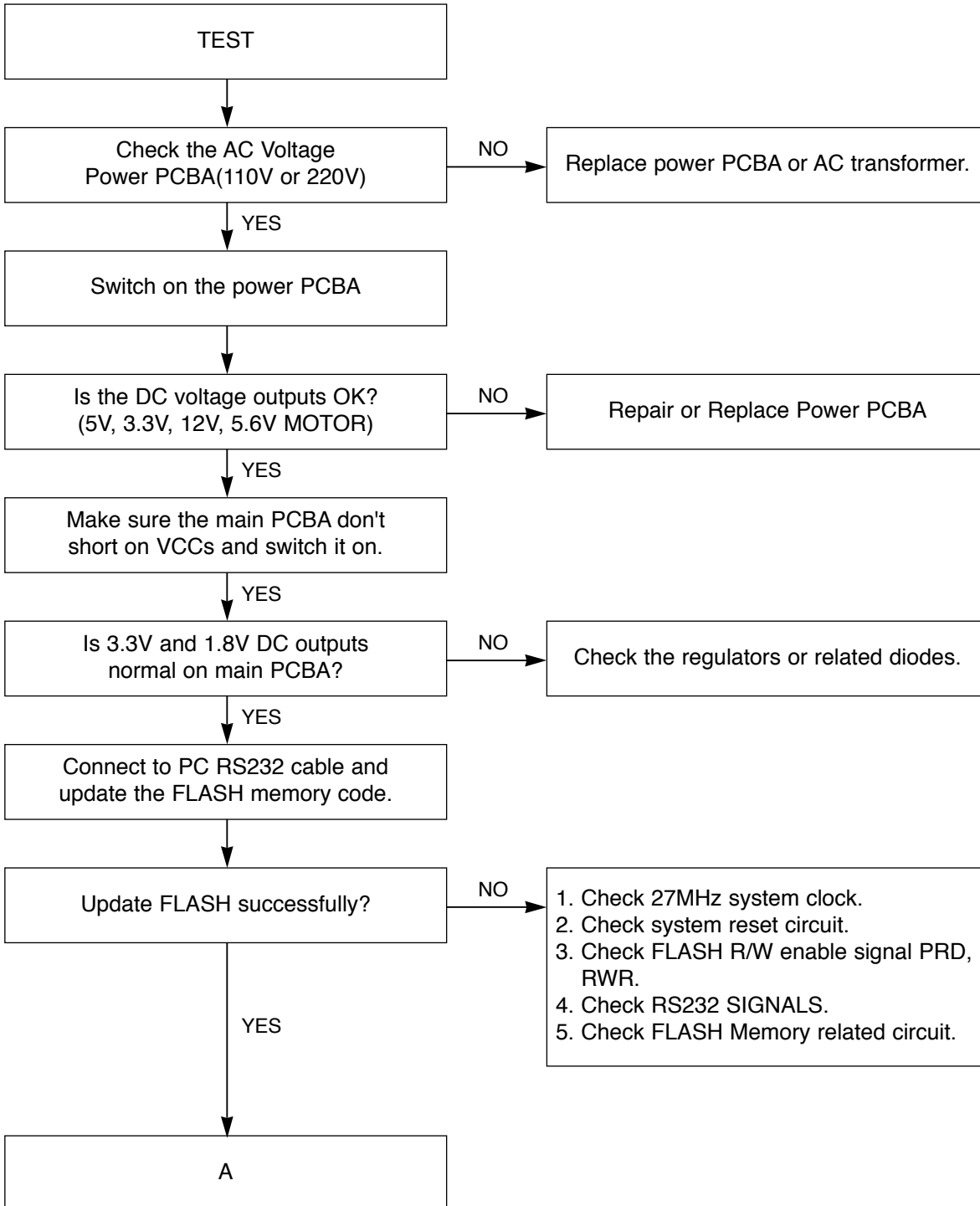

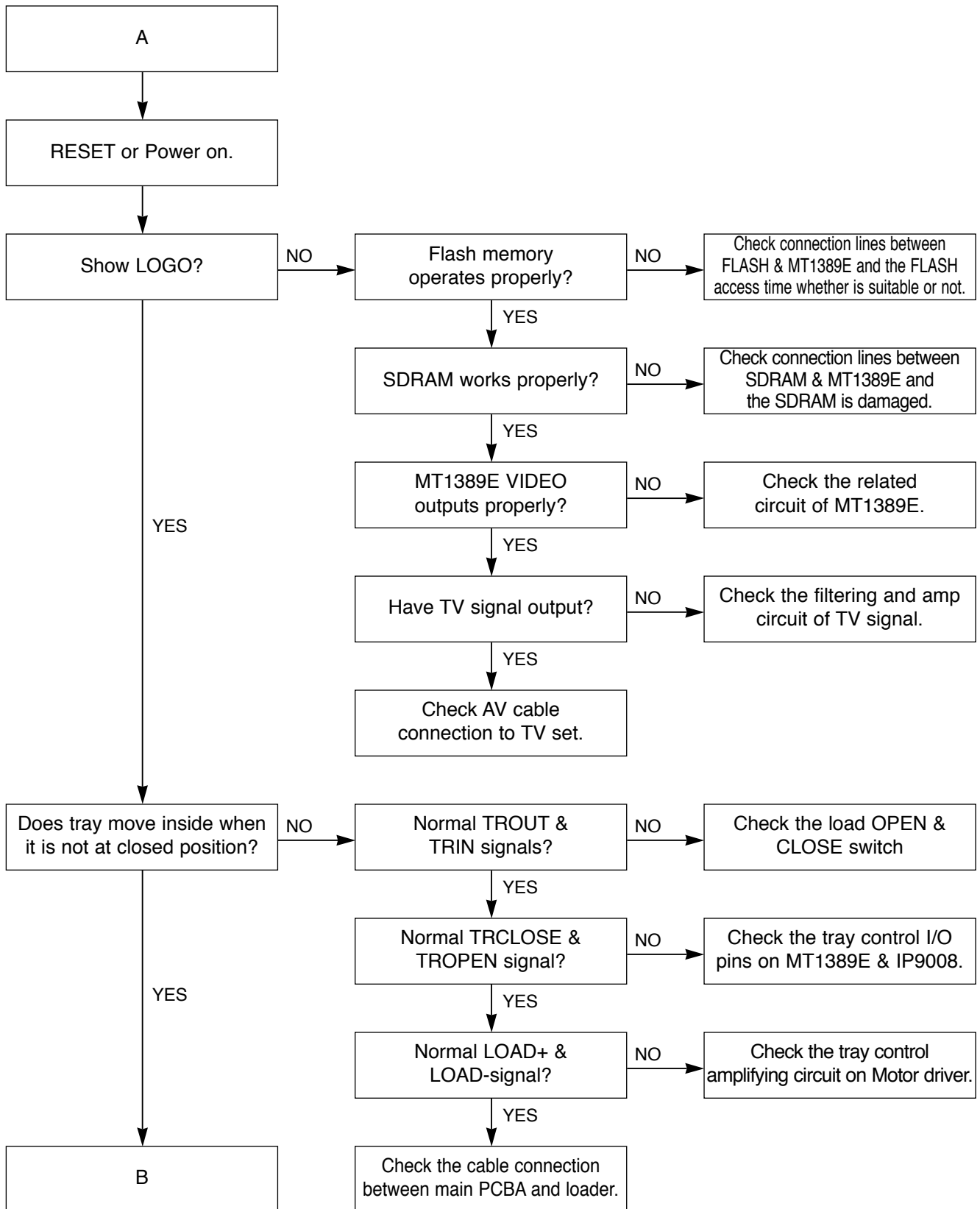



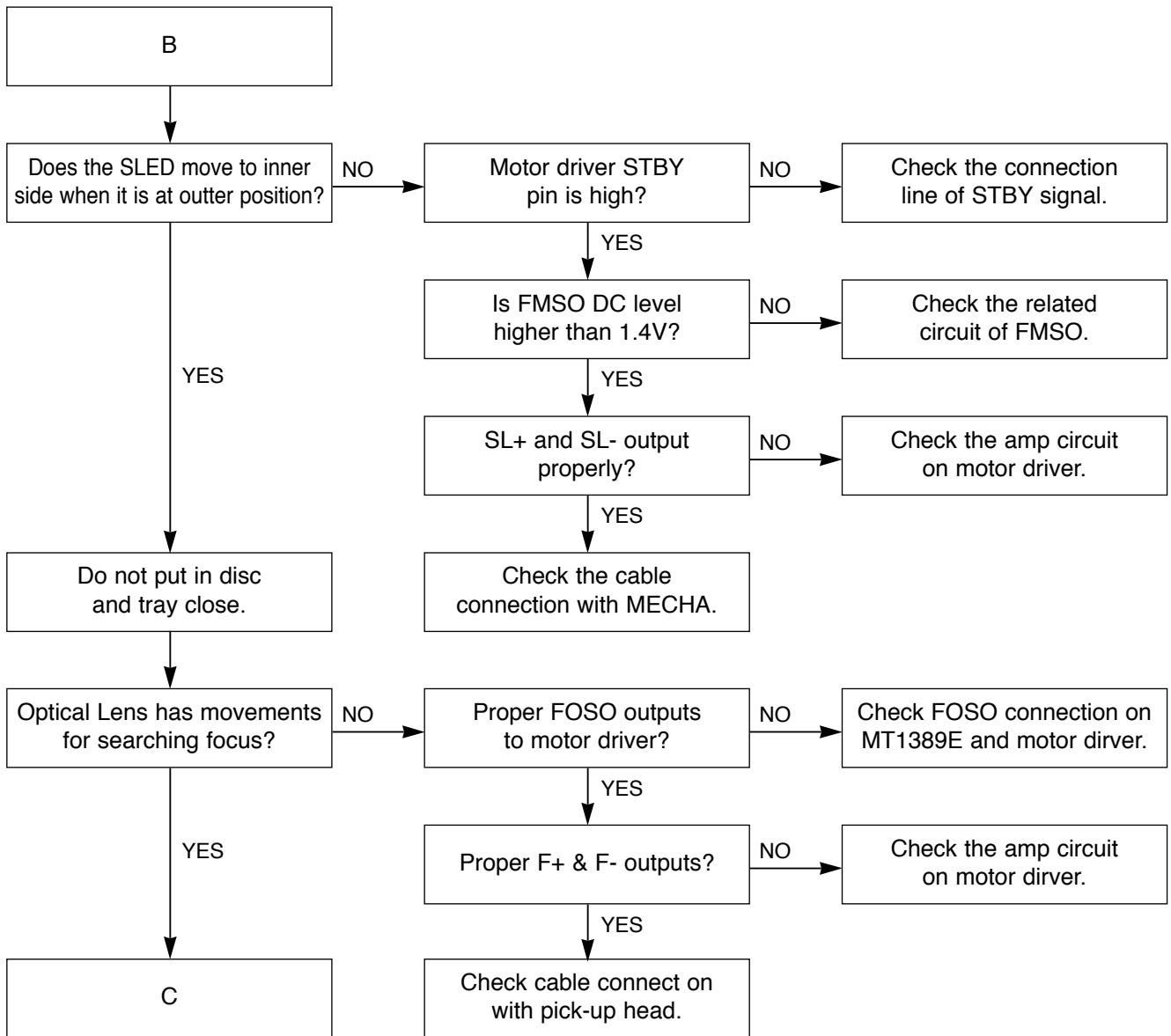

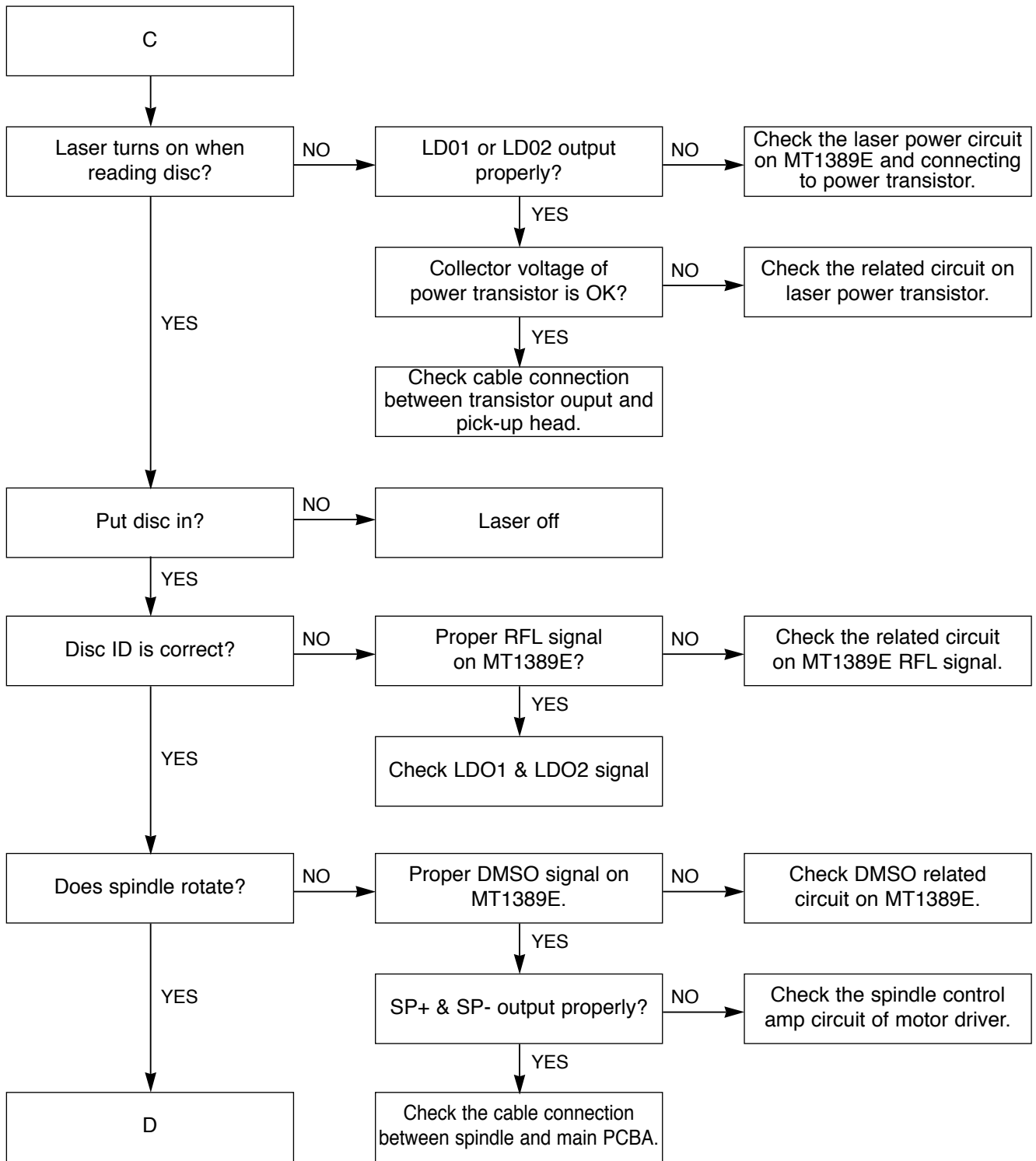

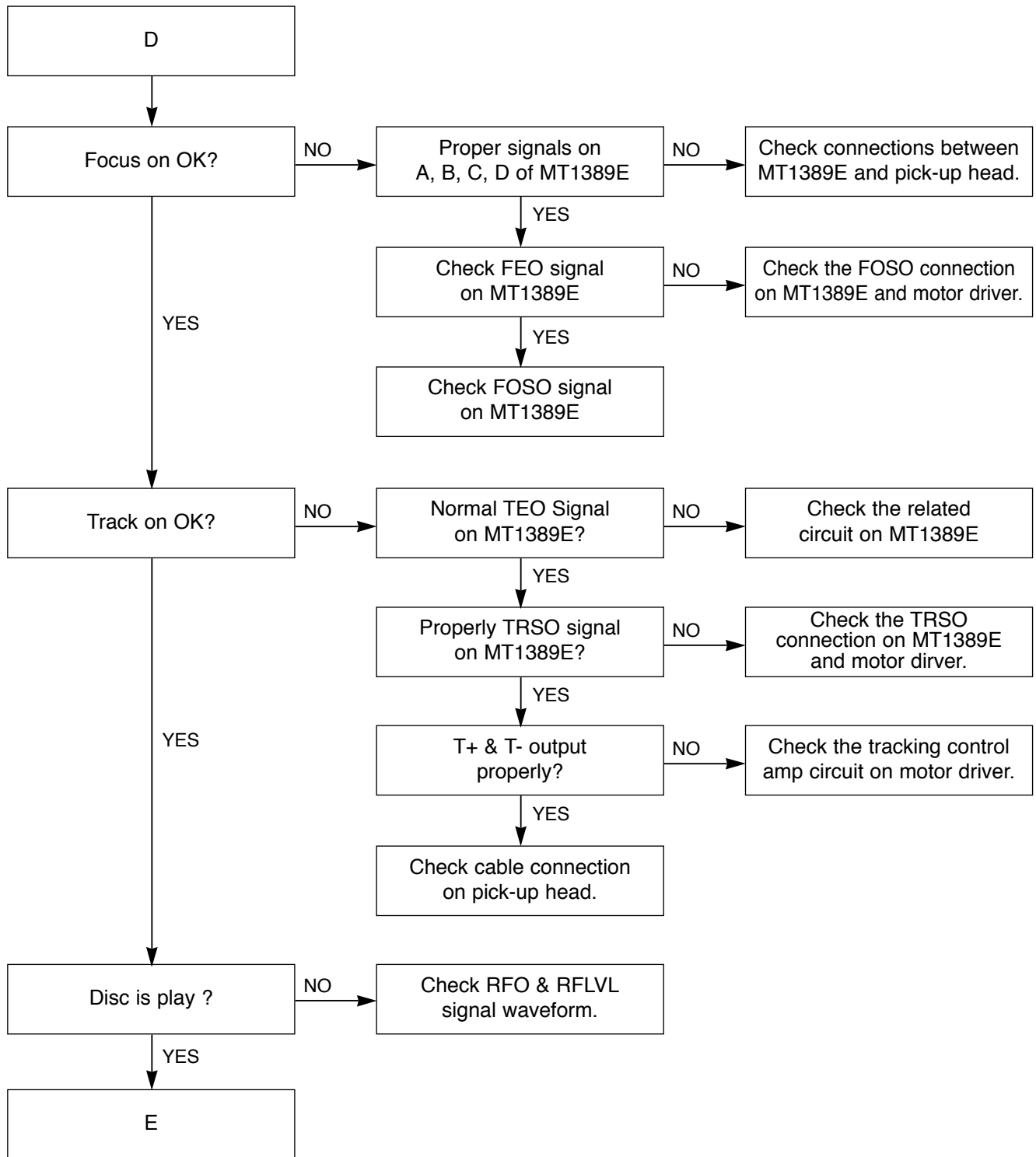

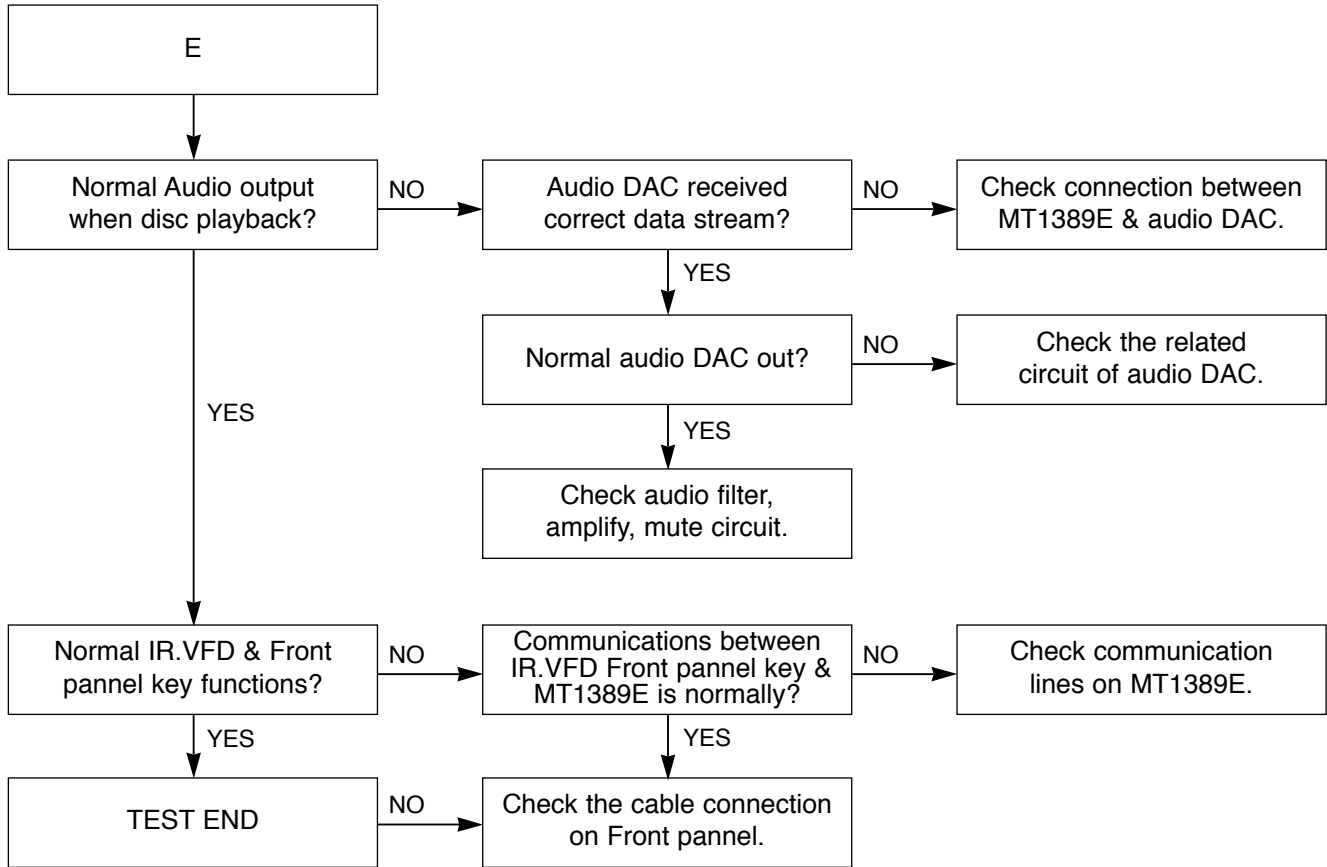

# DETAILS AND WAVEFORMS ON SYSTEM TEST AND DEBUGGIBG

## 1. SYSTEM 27MHz CLOCK, RESET, FLASH R/W SIGNAL

1) MT1389E main clock is at 27MHz (X601)

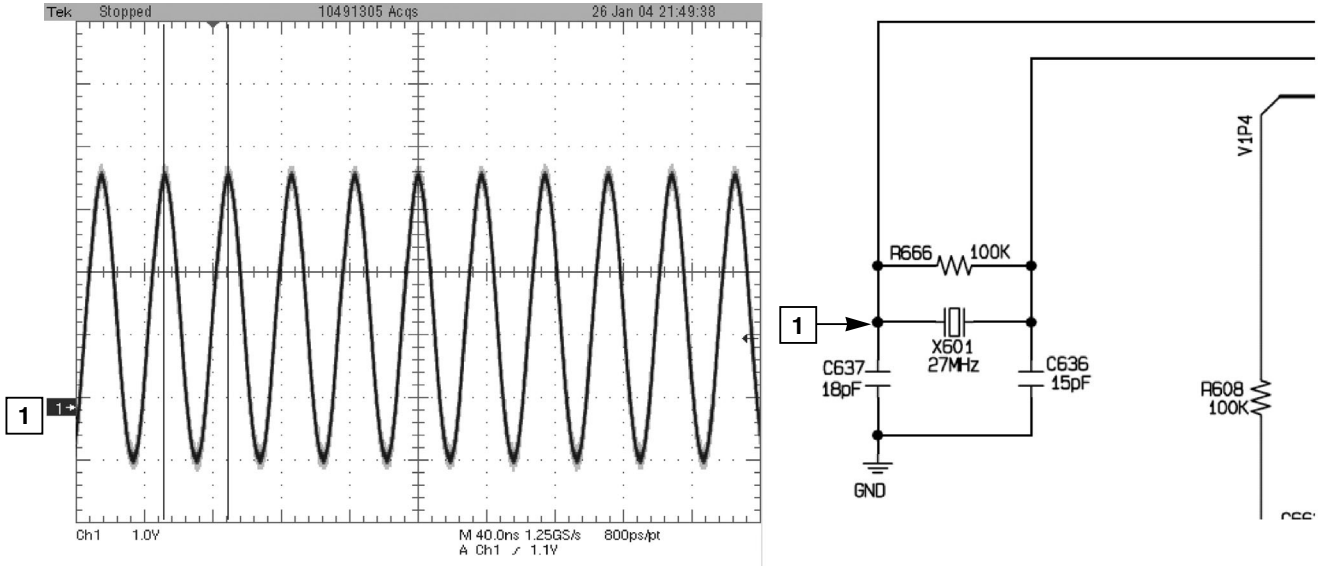

FIG 1-1

2) MT1389E reset is low active

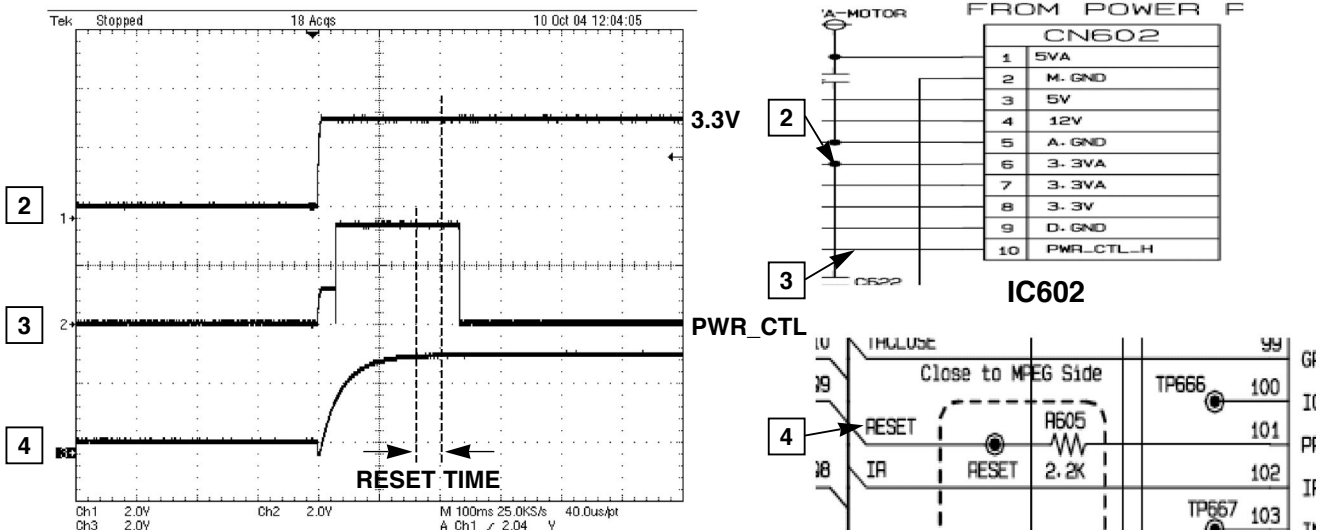

FIG 1-2

### 3) RS232 waveform during procedure (Downloading)

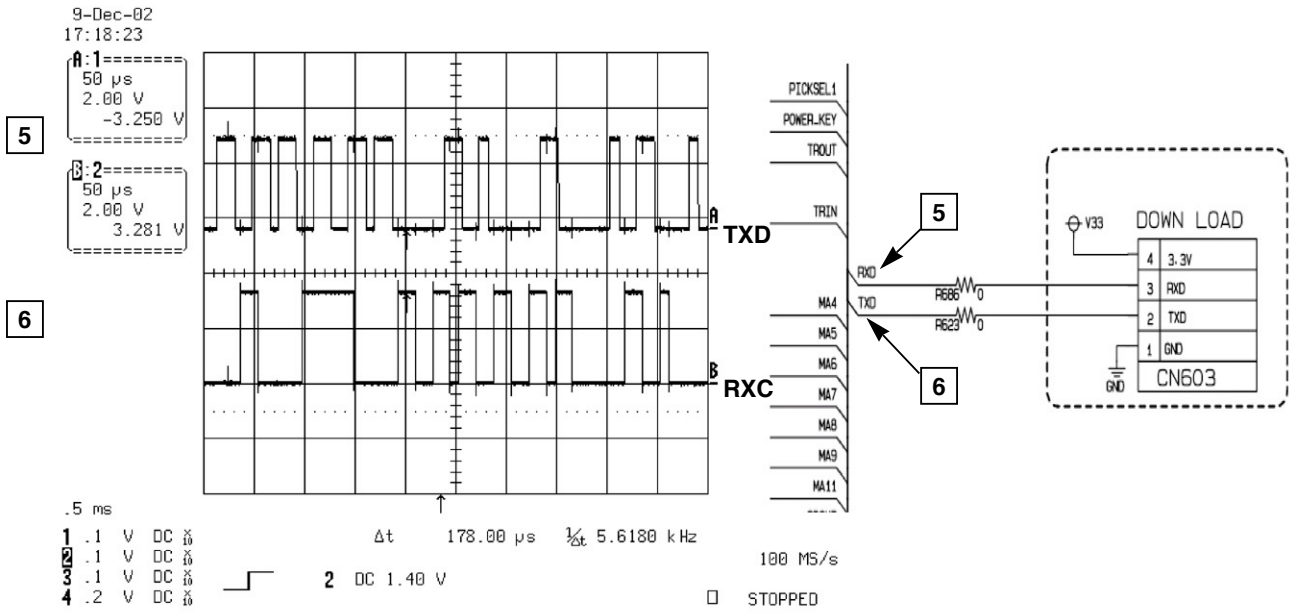

FIG 1-3

### 4) Flash R/W enable signal during download (Downloading)

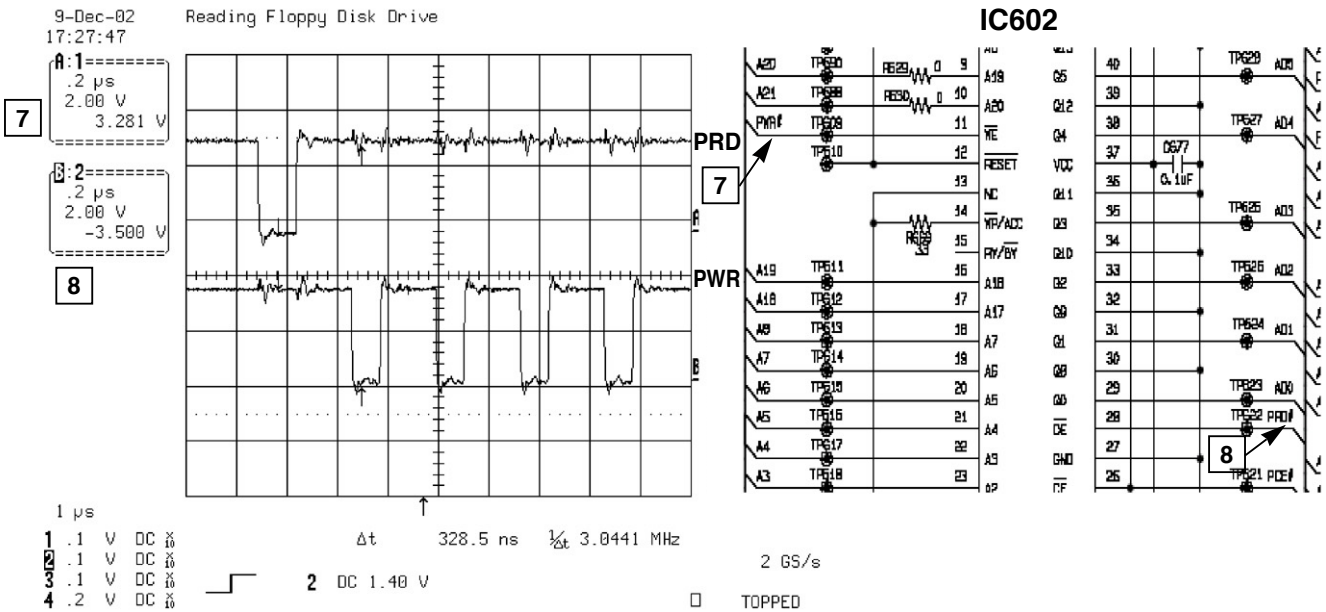

FIG 1-4

## 2. SDRAM CLOCK

DCLK = 128MHz, Vp-p=2.2, Vmax=2.7V

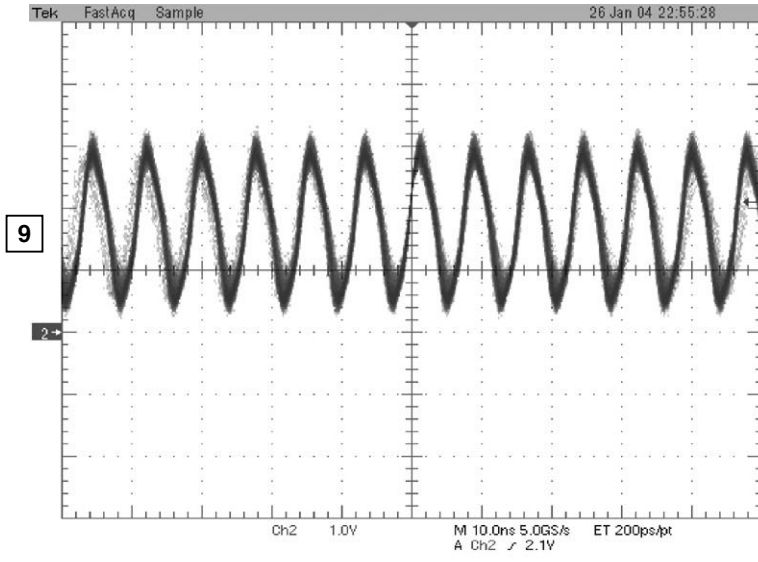
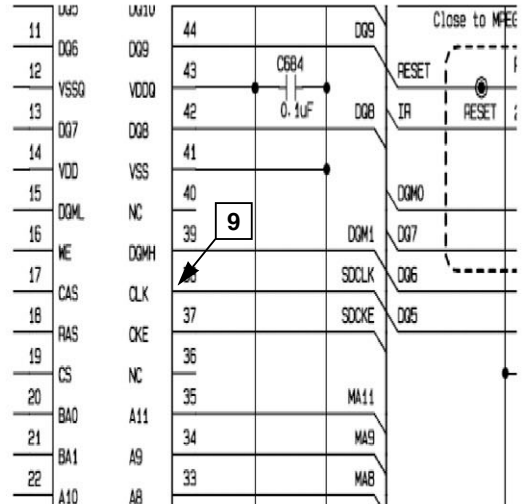

FIG 2-1

### IC603



## 3. TRAY OPEN/CLOSE SIGNAL

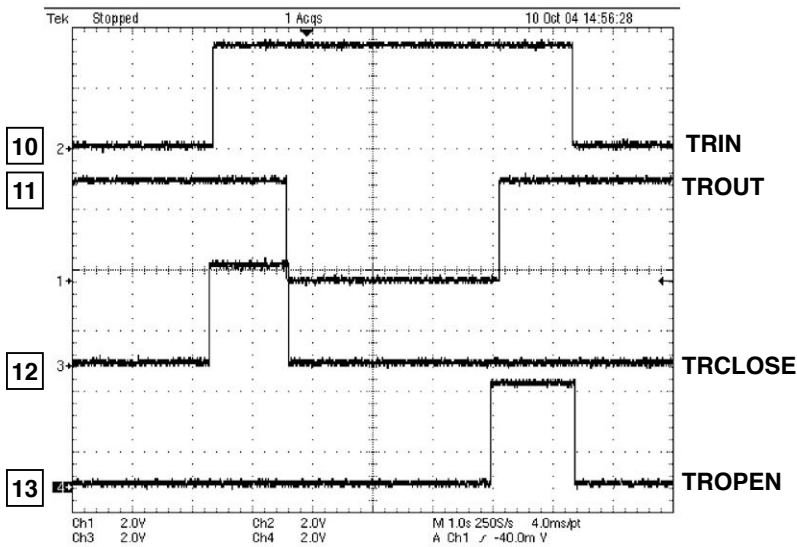
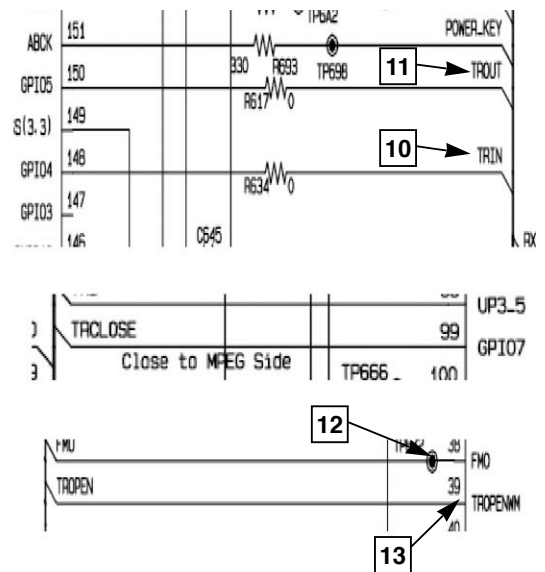

FIG 3-1

### IC601



#### 4. SLED CONTROL RELATED SIGNAL (NO DISC CONDITION)

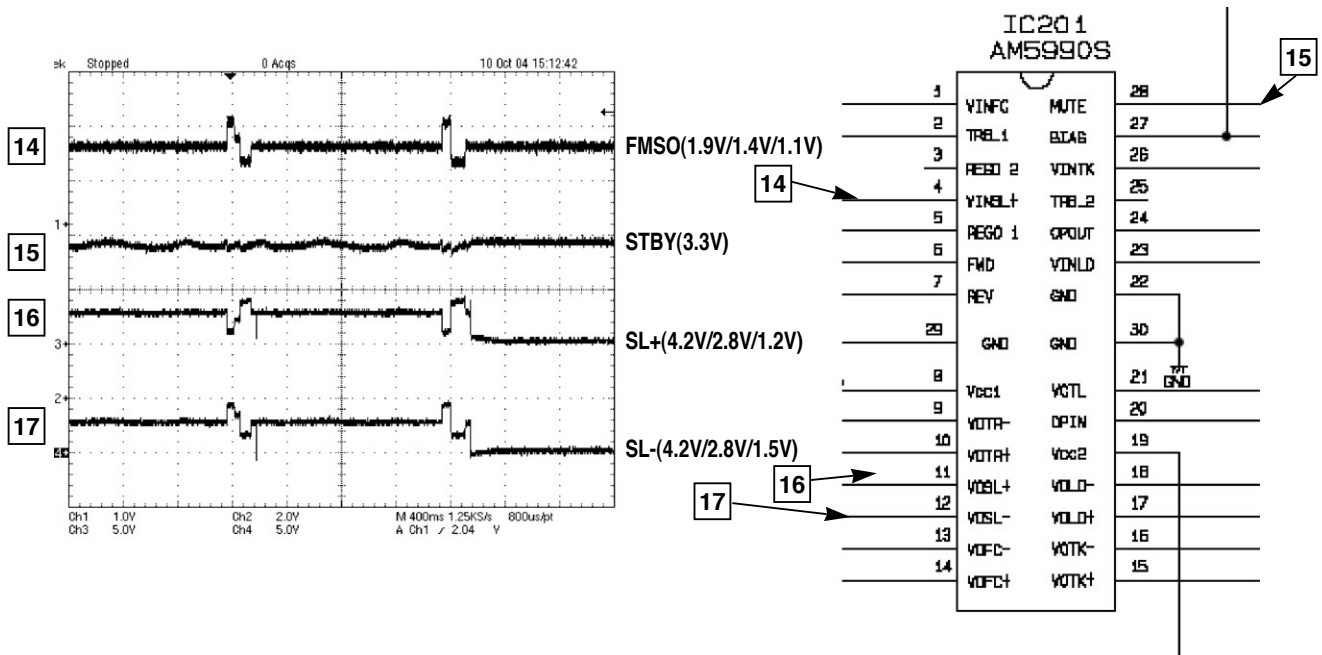

FIG 4-1

#### 5. LENS CONTROL RELATED SIGNAL (NO DISC CONDITION)

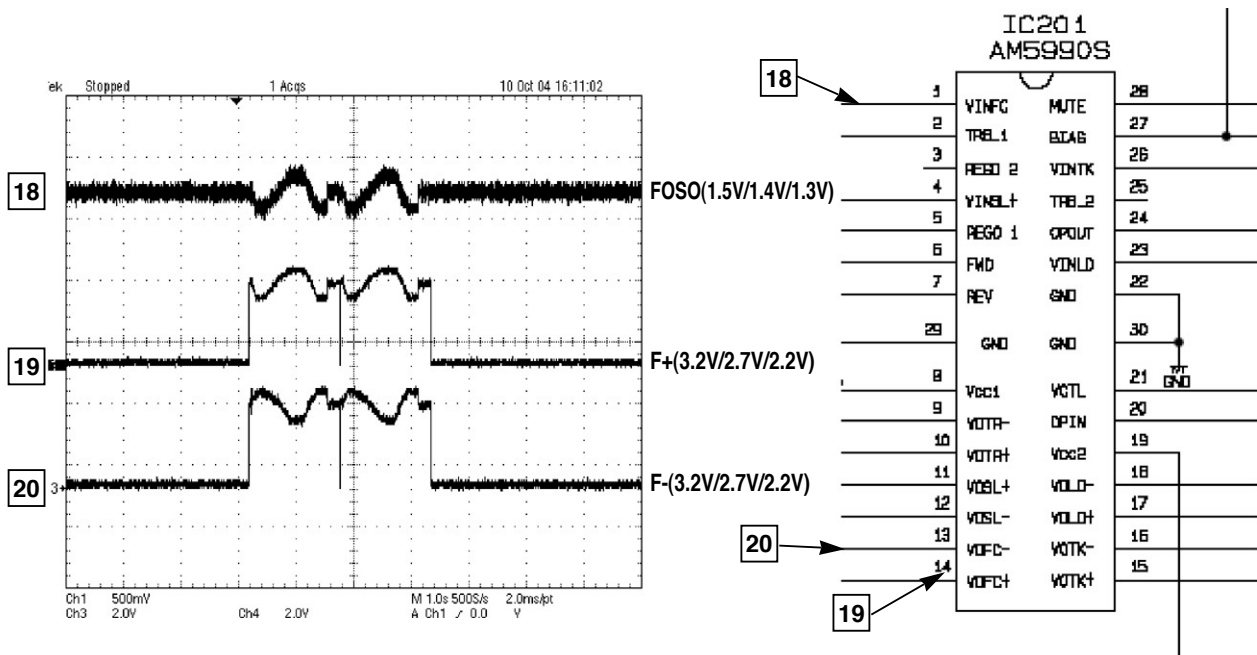

FIG 5-1



## 6. LASER POWER CONTROL RELATED SIGNAL (NO DISC CONDITION)

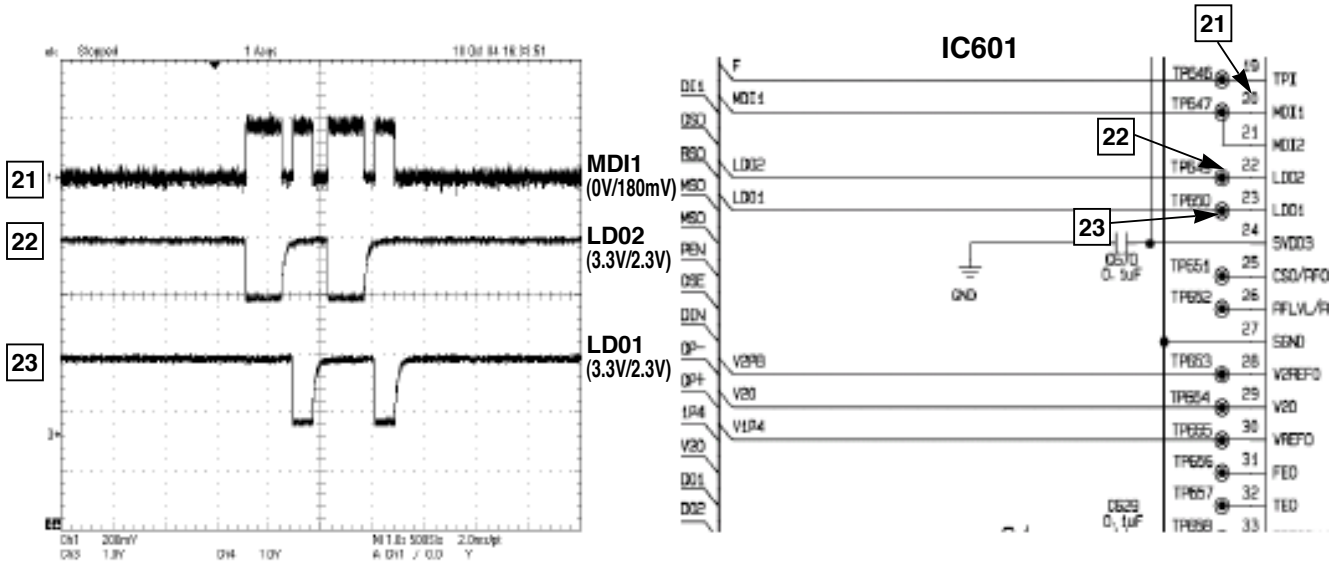

FIG 6-1

## 7. DISC TYPE JUDGEMENT WAVEFORM

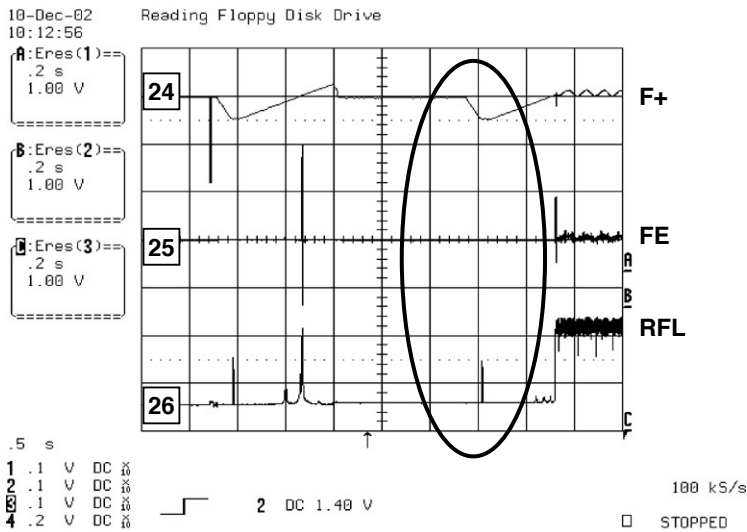
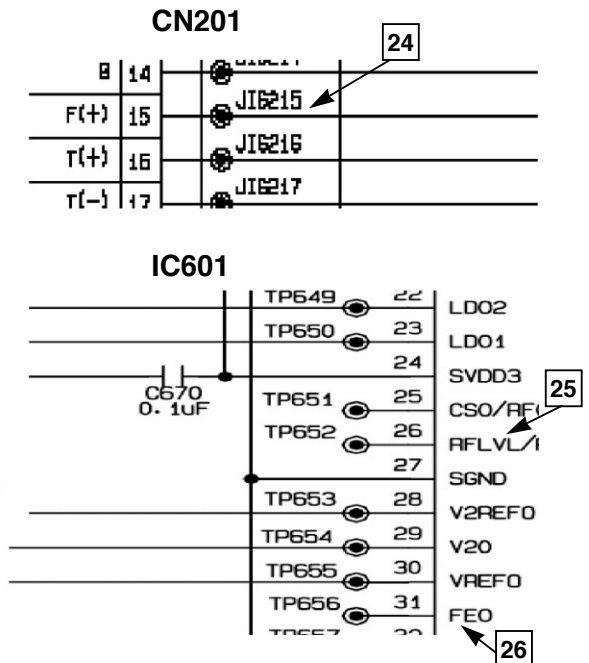

FIG 7-1 (DVD)



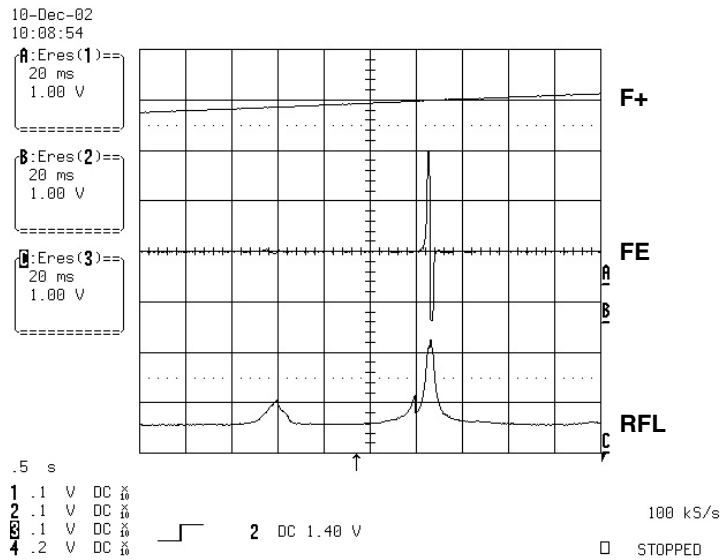

FIG 7-2 (DVD)

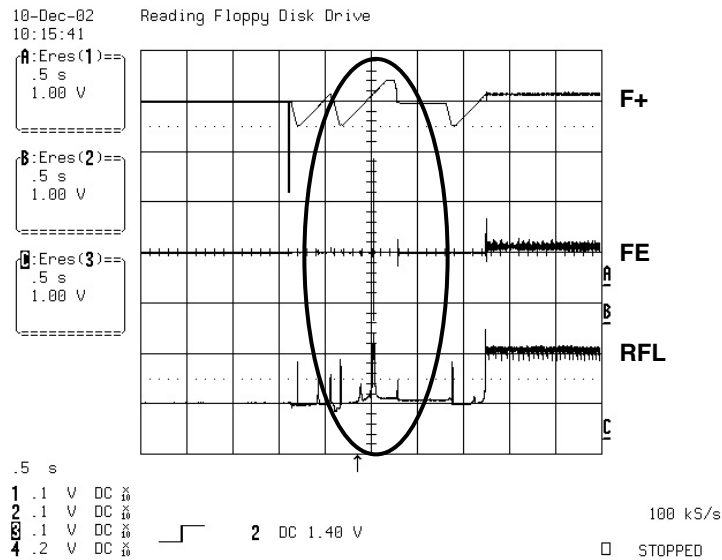

FIG 7-3 (CD)

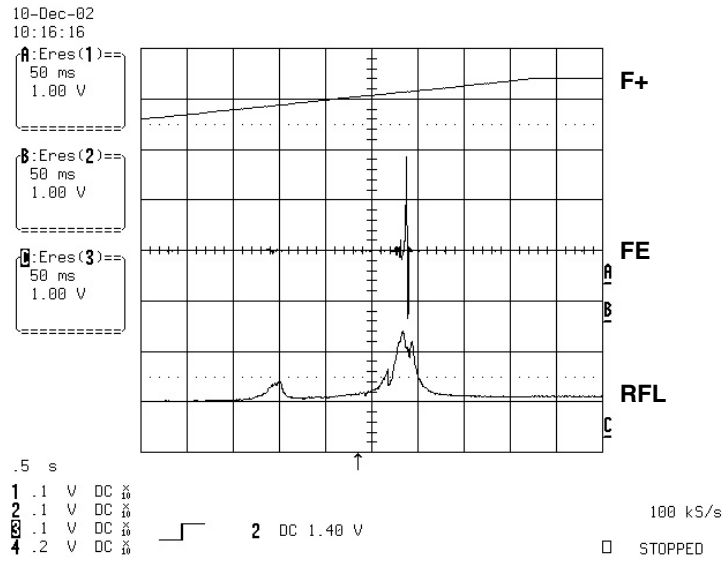

FIG 7-4 (CD)

## 8. FOCUS ON WAVEFORM

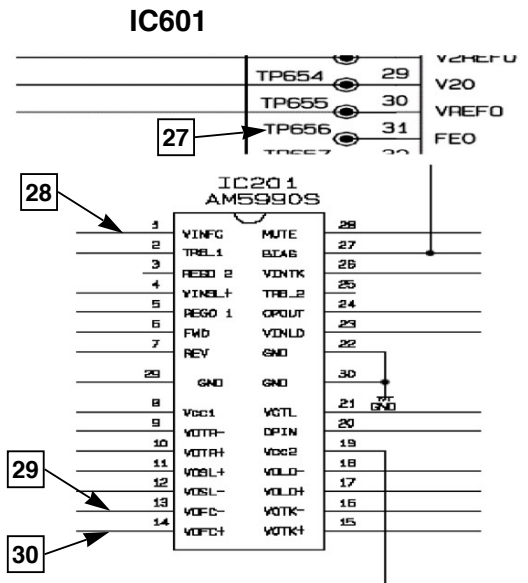
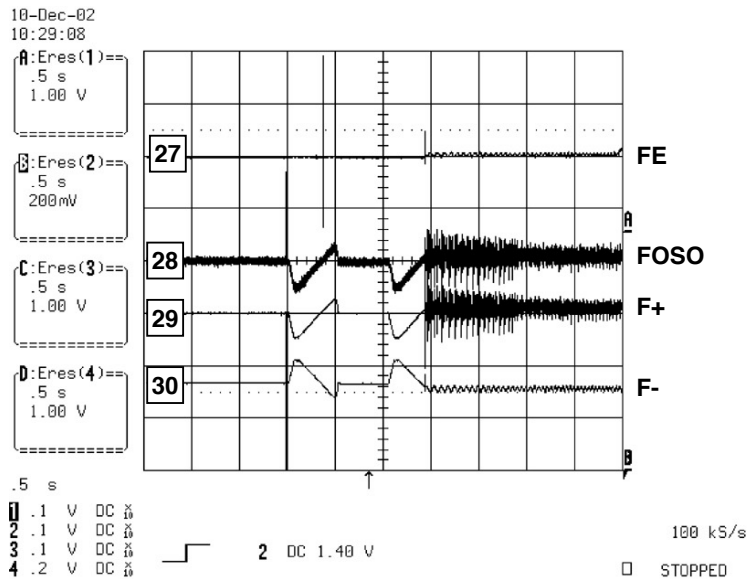

FIG 8-1 (DVD)

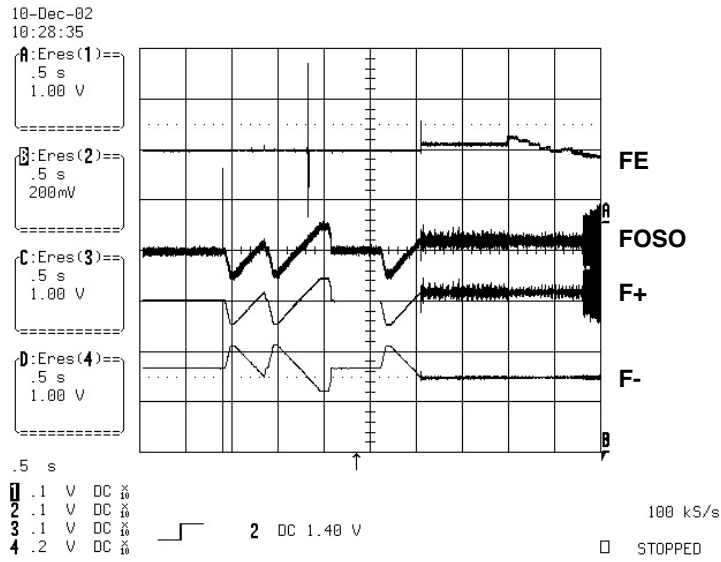

FIG 8-2 (CD)

## 9. SPINDLE CONTROL WAVEFORM (NO DISC CONDITION)

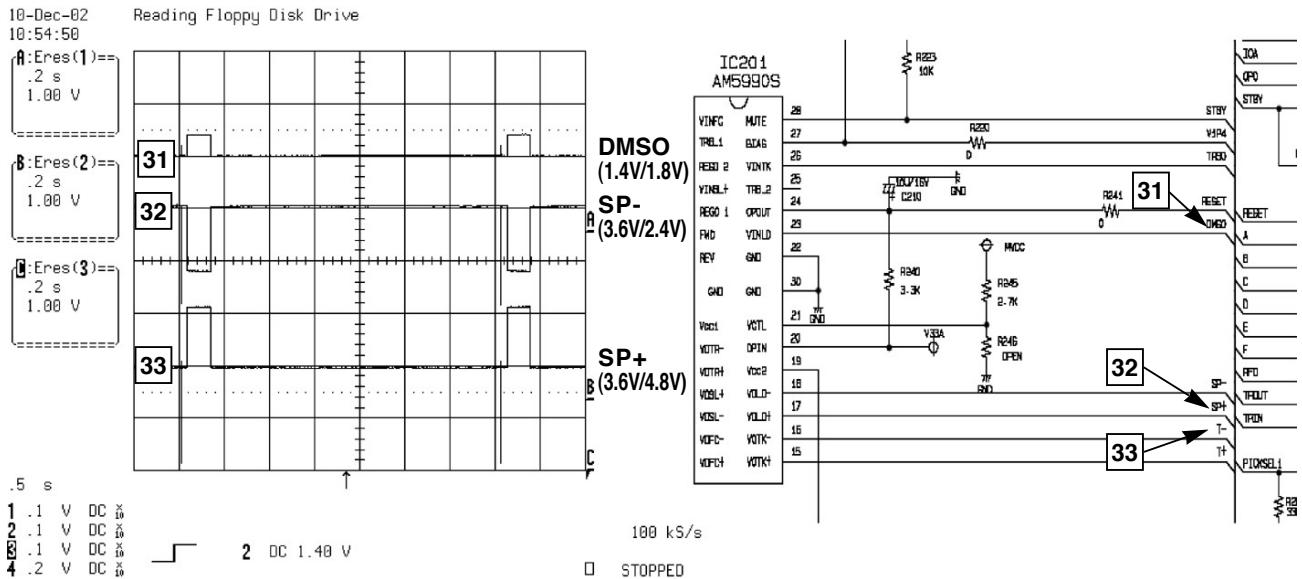

FIG 9-1

# 10. TRACKING CONTROL RELATED SIGNAL (SYSTEM CHECKING)

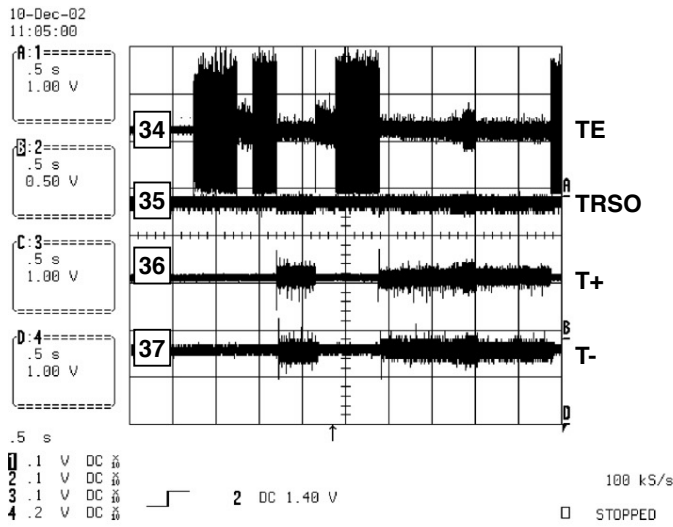

FIG 10-1 (DVD)

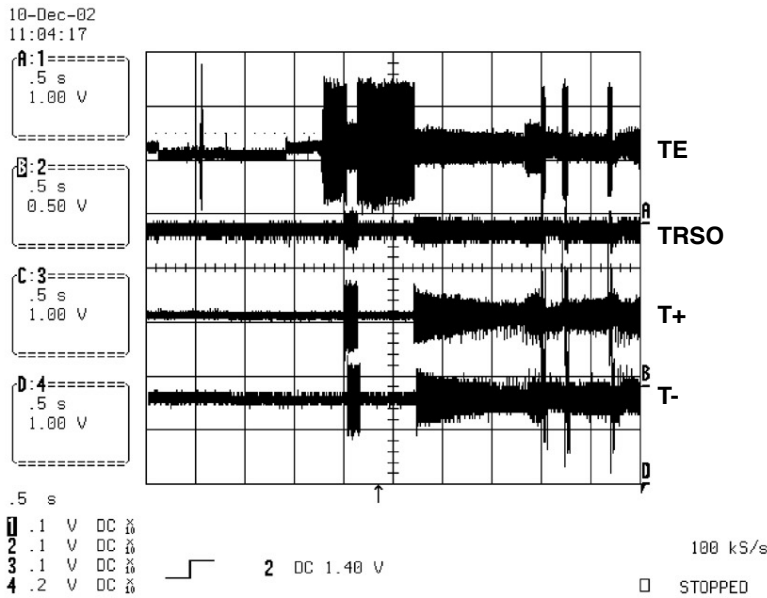
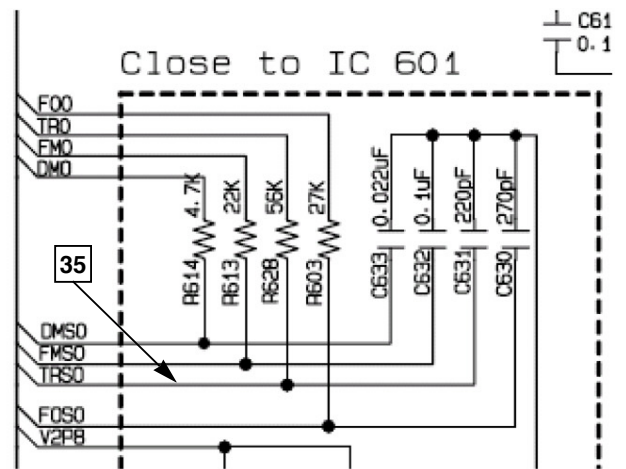
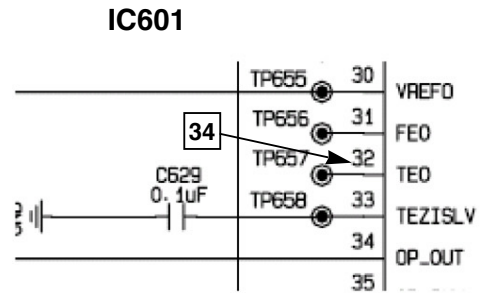
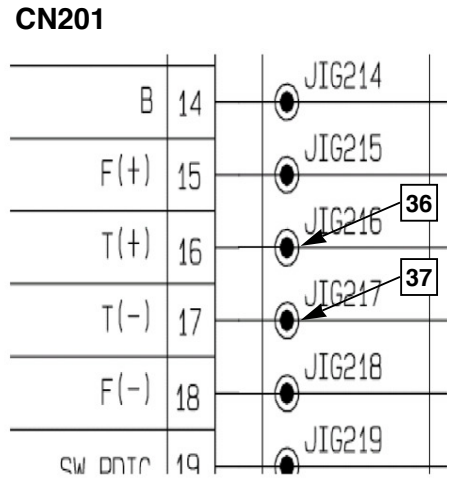

FIG 10-2 (CD)





## 2) COMPOSITE VIDEO SIGNAL

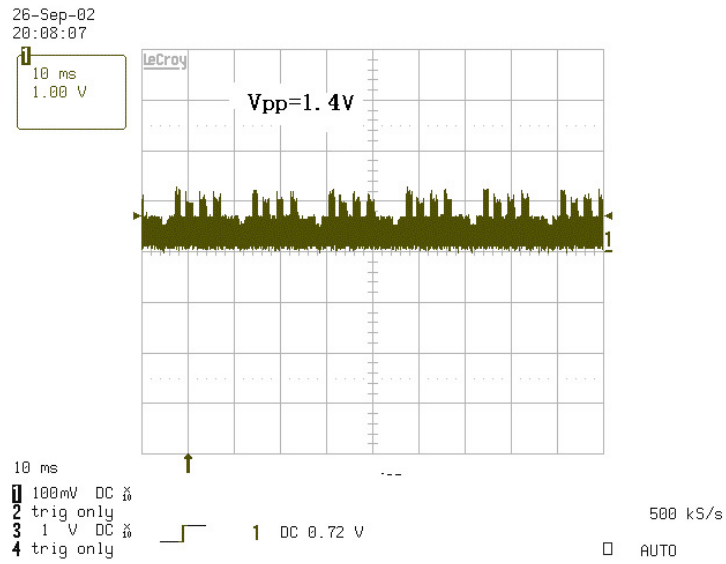

FIG 12-2

## 13. AUDIO OUTPUT FROM MT1389E

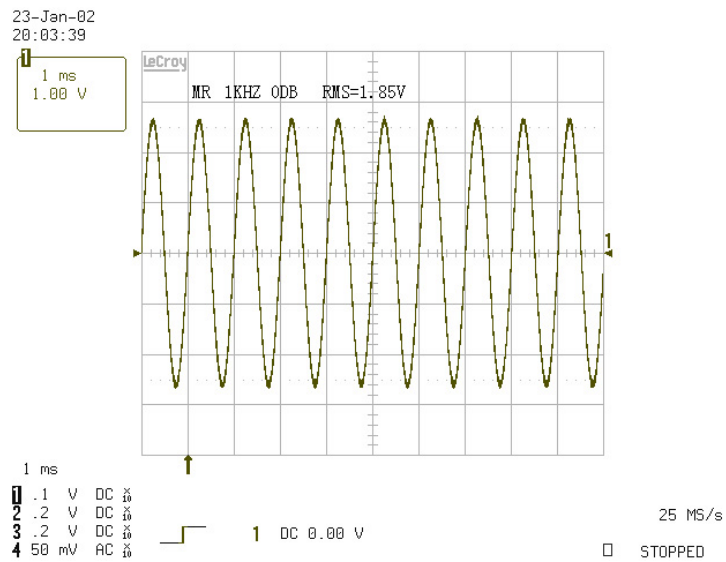

FIG 13-1

# CONNECTOR PICTURE

## 1. FULL CONNECTOR PICTURE





## 2. CN201 CONNECTOR PICTURE

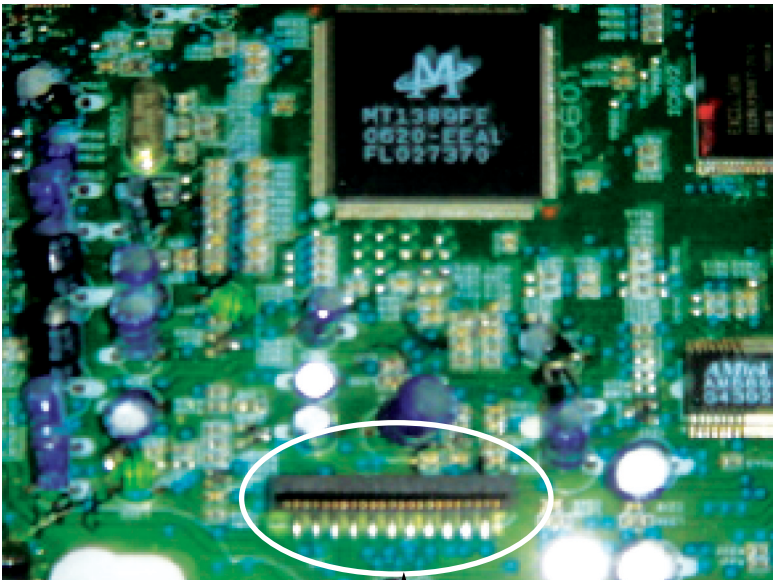

FROM PICKUP

CN201			
NG/FHM/VCC	1	J1G2001	
FHM	2	J1G2002	
DVCLLO	3	J1G2003	R856
NONICOMP/SBY	4	J1G2004	L8106
DVCLVR	5	J1G2005	
GND	6	J1G2006	C860
VREF/VIC	7	J1G2007	
VCC	8	J1G2008	L207
F	9	J1G2009	
E	10	J1G2010	
A	11	J1G2011	
D	12	J1G2012	
C	13	J1G2013	
B	14	J1G2014	
F(+)	15	J1G2015	
F(+)	16	J1G2016	
F(-)	17	J1G2017	
F(-)	18	J1G2018	
SM_PDI0	19	J1G2019	
GND	20		
COLLO	21	J1G2021	
NONVAP0	22	J1G2022	
COLVR	23	J1G2023	

CN201(22PIN)

## 3. CN202 CONNECTOR PICTURE

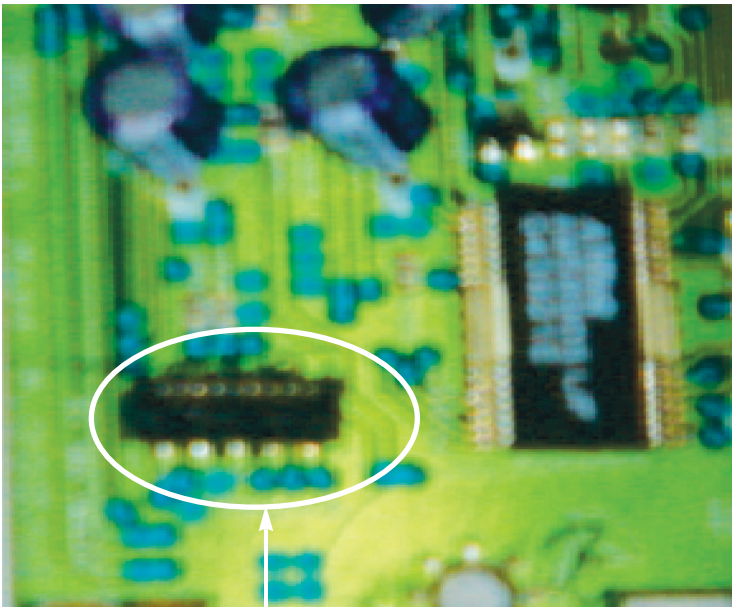

GND

CN202			
LH+	1	J1G220	
LH+	2	J1G221	
OPEN	3	J1G222	
CLOSE	4	J1G223	
GND	5	J1G224	R2
FH+	6	J1G227	1
FH+	7	J1G228	
SP+	8	J1G225	
SP-	9	J1G224	

CN202 (9PIN)

#### 4. CN601 CONNECTOR PICTURE

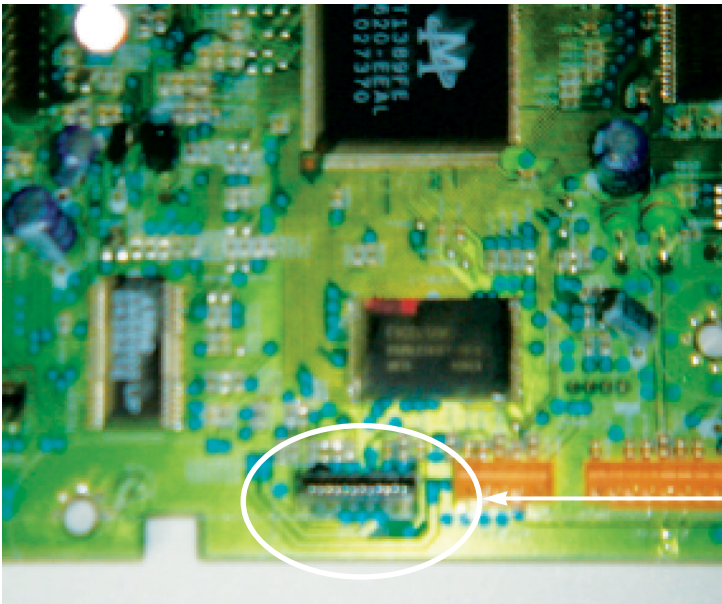

CN601  
(12PIN)

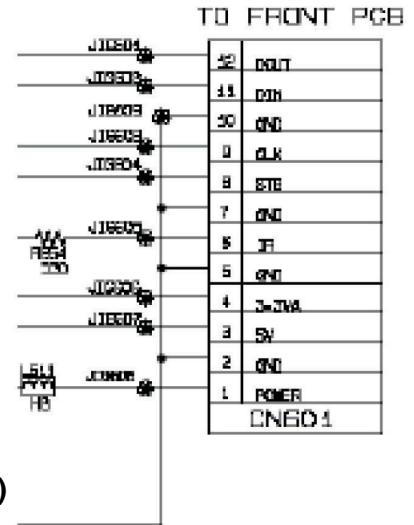

#### 5. CN602 CONNECTOR PICTURE

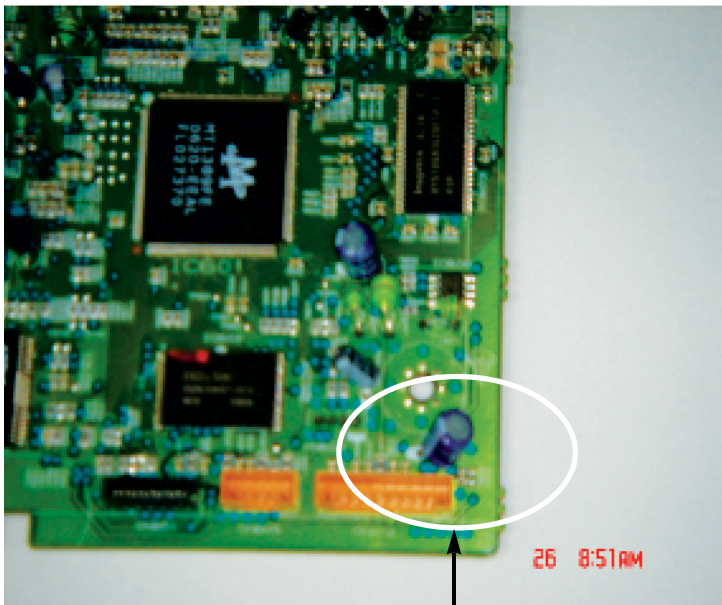

CN602 (10PIN)

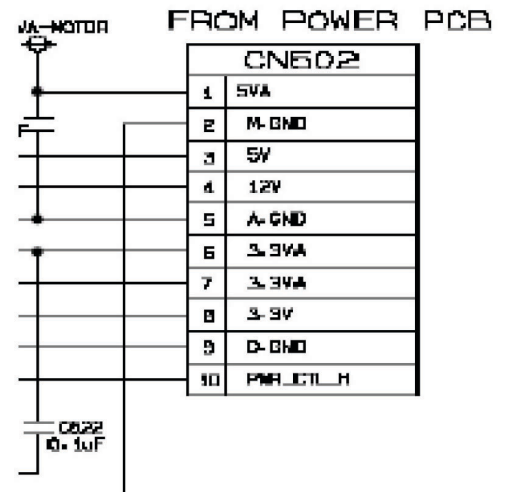

## 6. CN605 CONNECTOR PICTURE

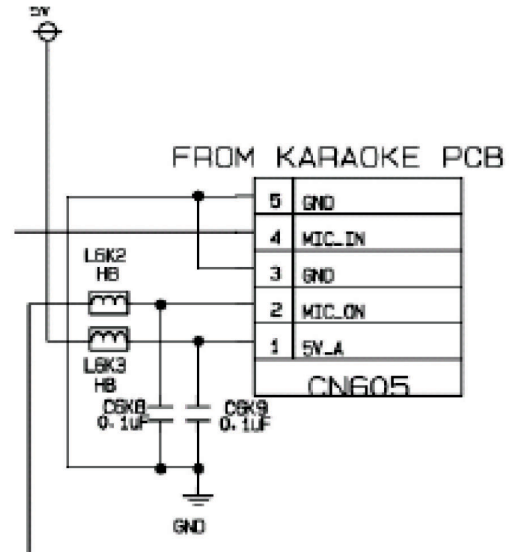
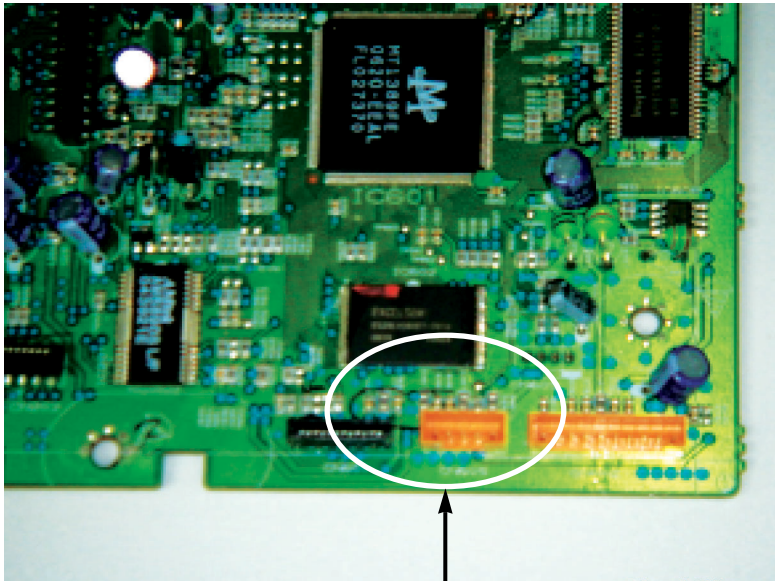

CN605 (5PIN)

## 7. CN703 CONNECTOR PICTURE

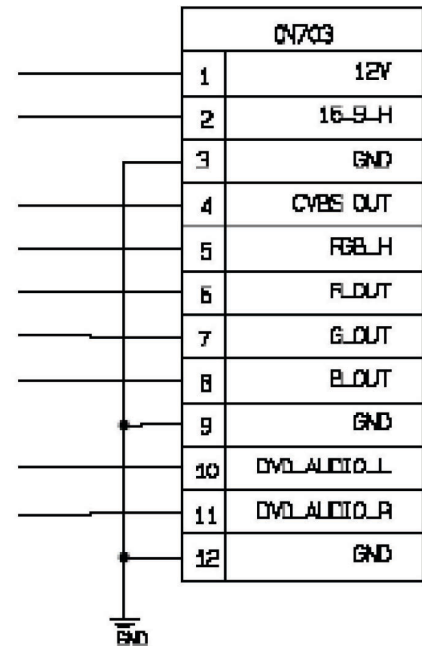
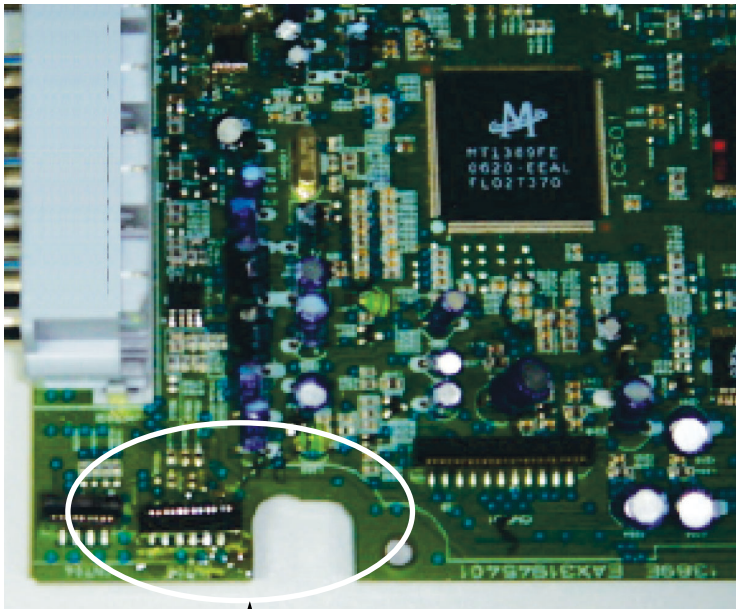

CN703 (12PIN)

## 8. CN704 CONNECTOR PICTURE

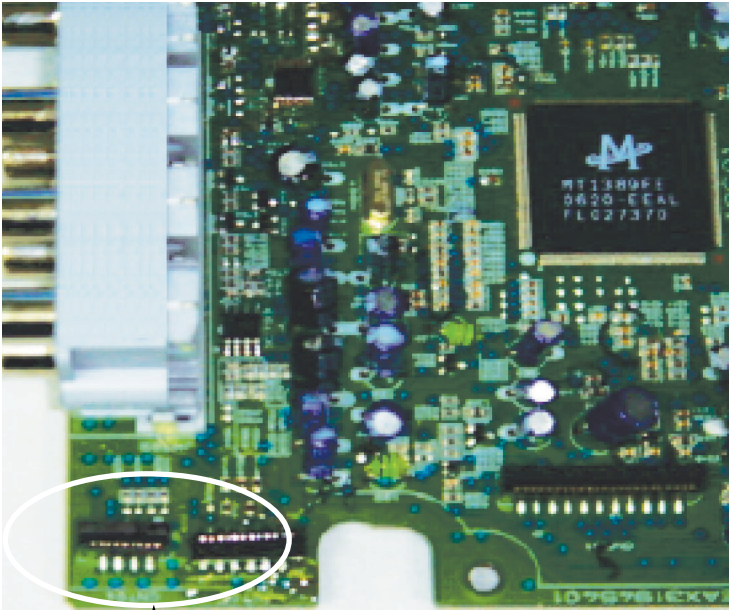

WITH 5.1CHANNEL OPTION

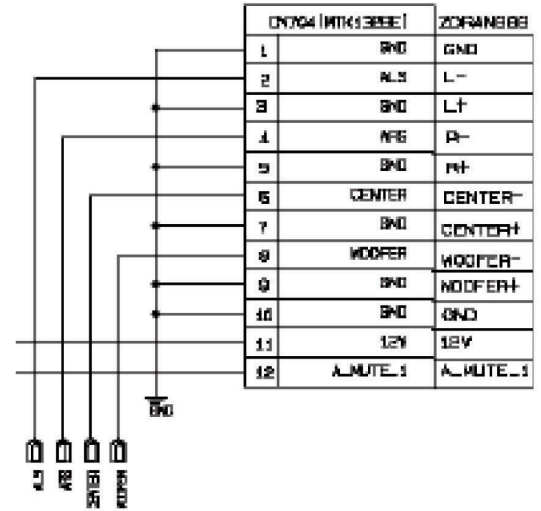

CN704 (9PIN)

## 9. P101 CONNECTOR PICTURE

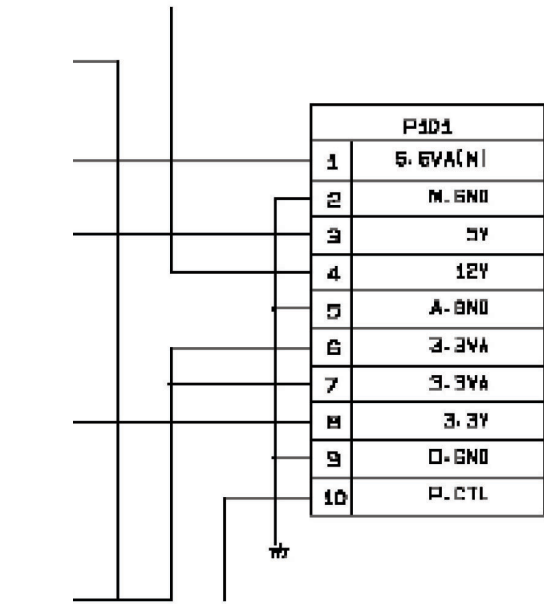
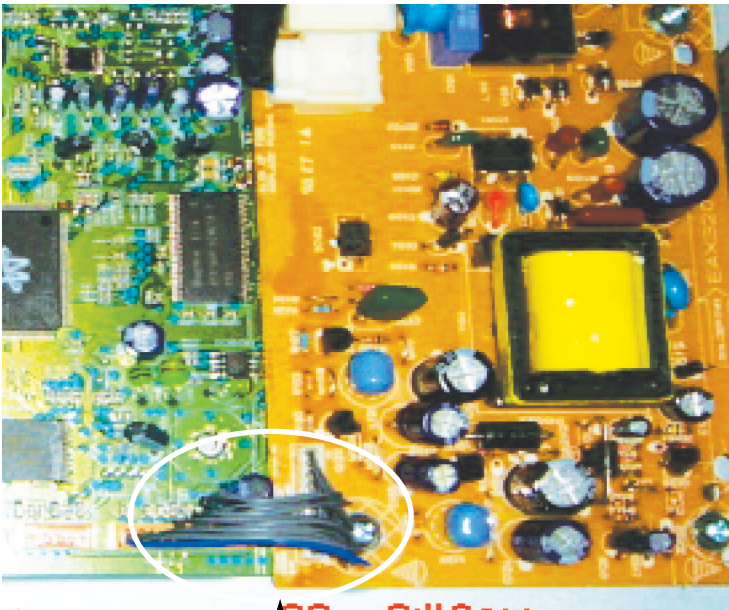

P101 (10PIN)

# BLOCK DIAGRAMS

## 1. OVERALL BLOCK DIAGRAM

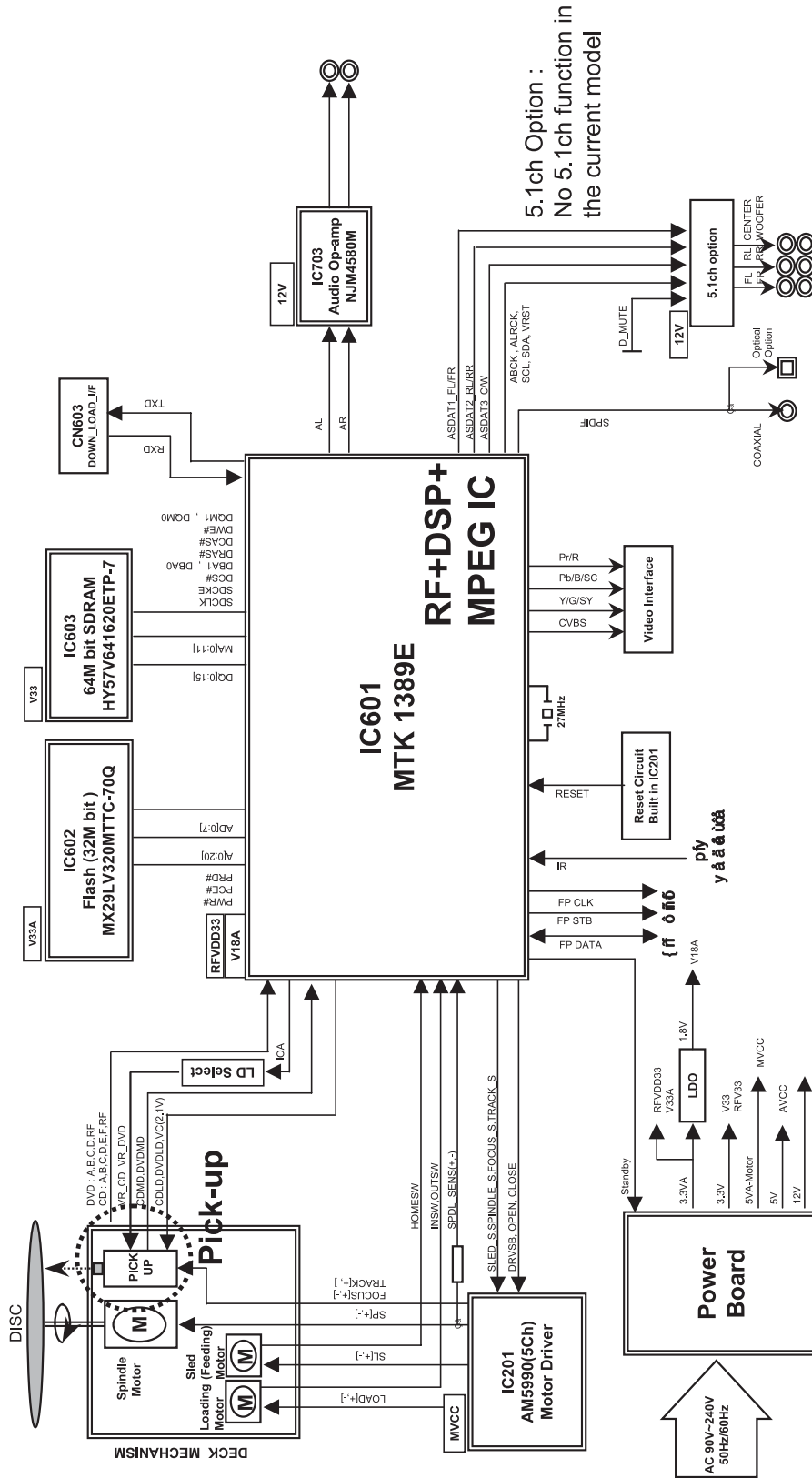

## 2. POWER SUPPLY BLOCK DIAGRAM

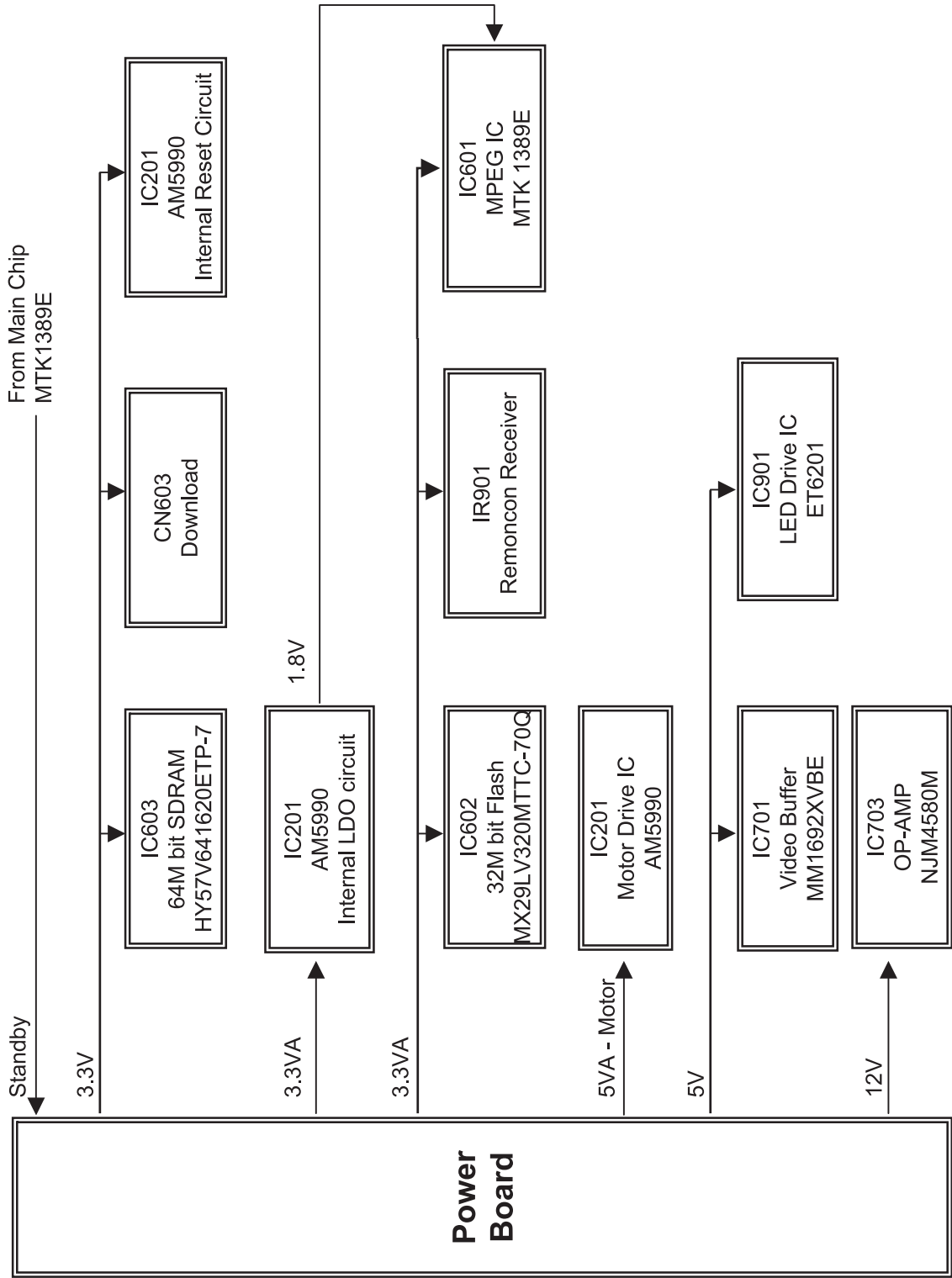

### 3. SERVO BLOCK DIAGRAM

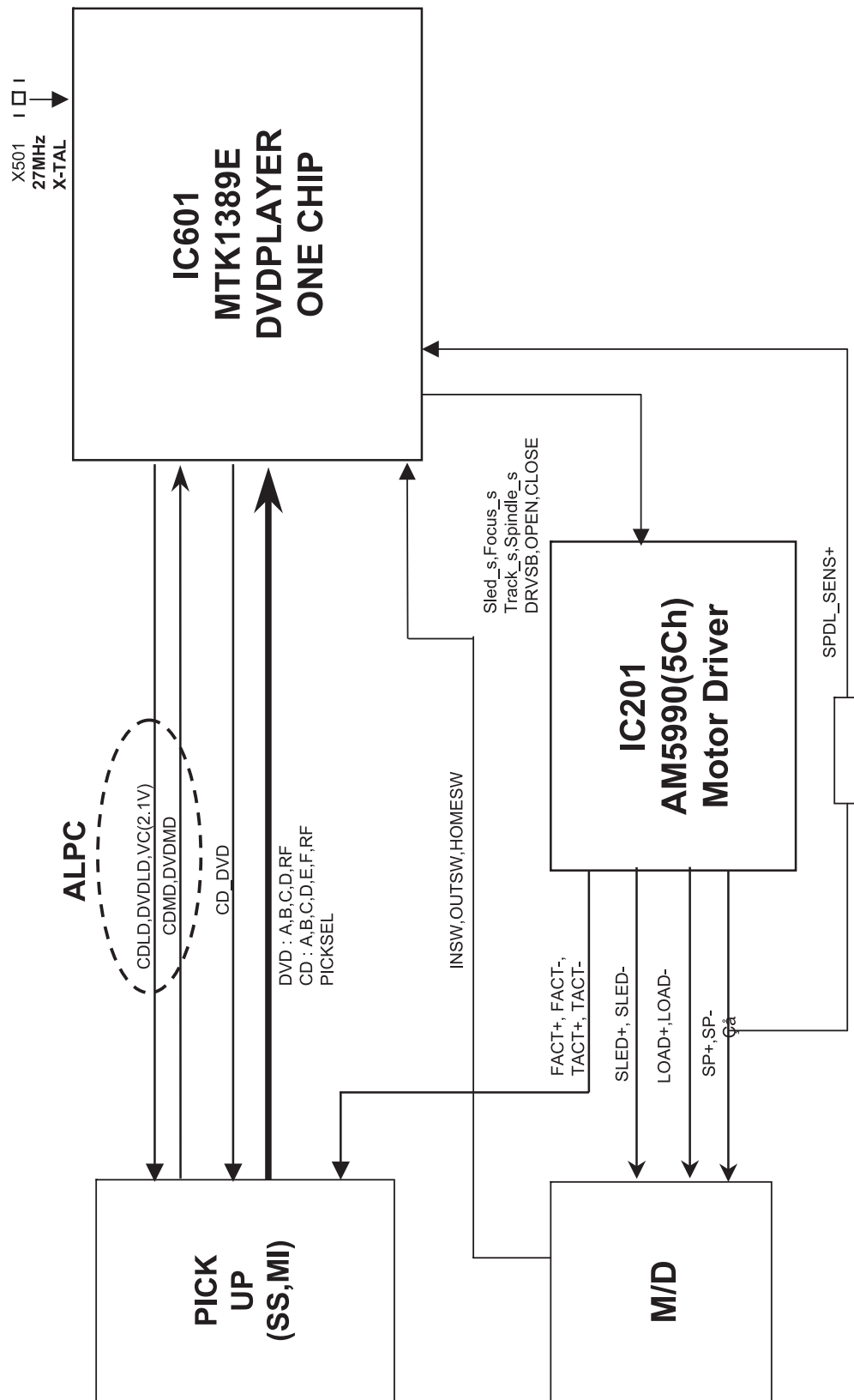

# 4. MPEG & MEMORY BLOCK DIAGRAM

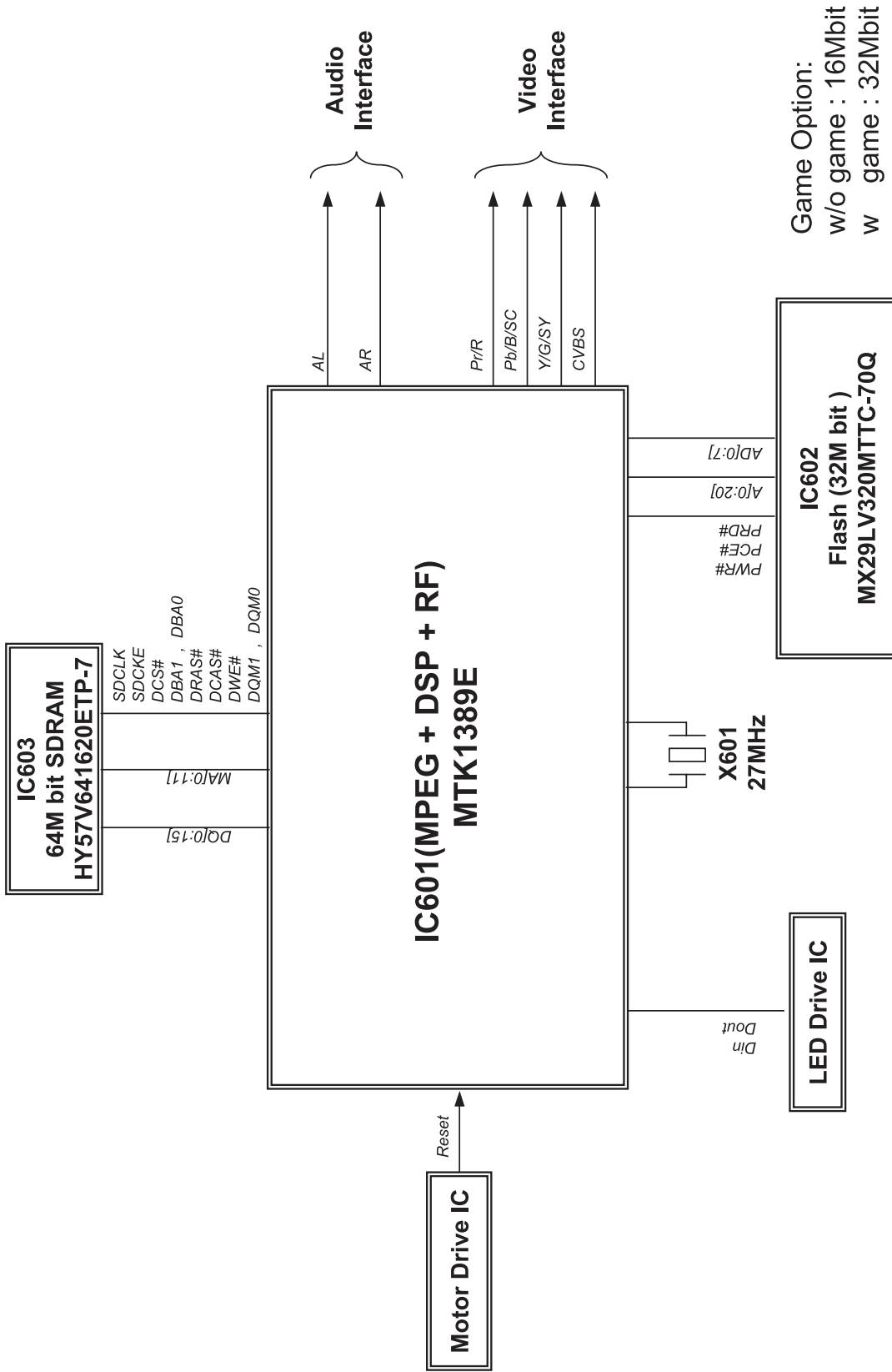



## 5. VIDEO BLOCK DIAGRAM

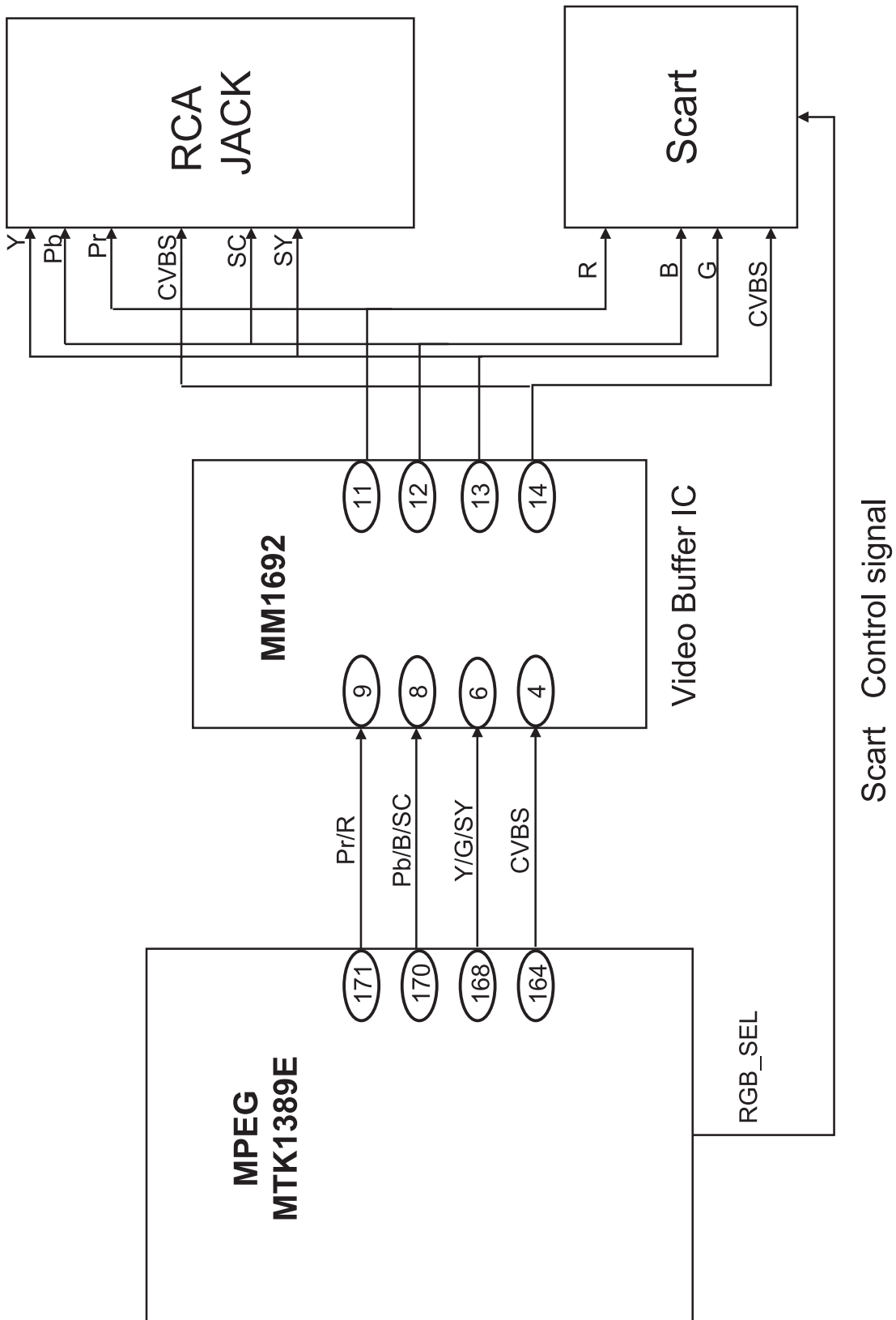

# 6. AUDIO BLOCK DIAGRAM

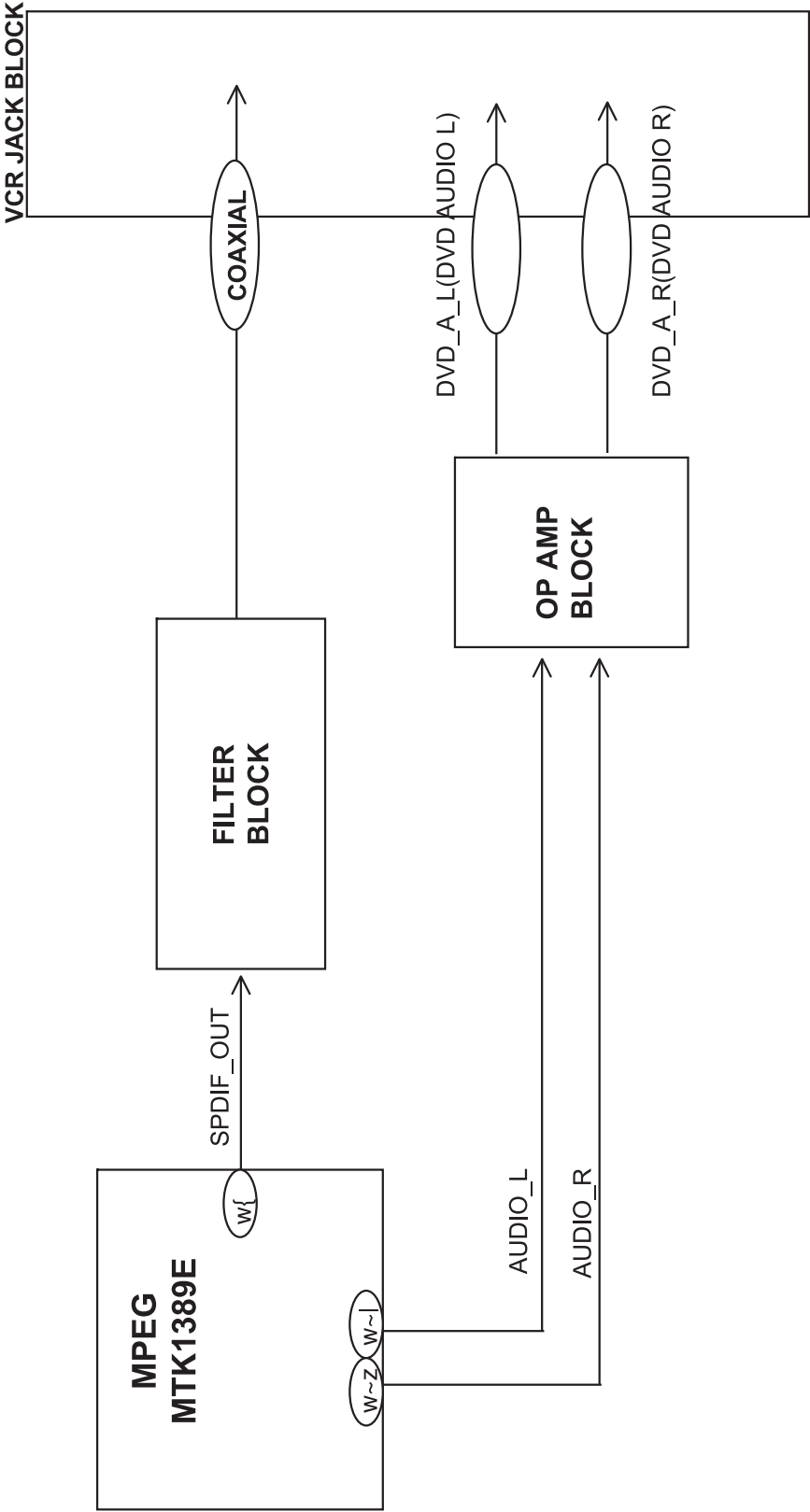

# MEMO

A series of horizontal dotted lines for writing.

# CIRCUIT DIAGRAMS

## 1. POWER (SMPS) CIRCUIT DIAGRAM

### IMPORTANT SAFETY

WHEN SERVICING THIS CHASSIS, UNDER NO CIRCUMSTANCES SHOULD THE ORIGINAL DESIGN BE MODIFIED OR ALTERED WITHOUT PERMISSION FROM THE LG CORPORATION. ALL COMPONENTS SHOULD BE REPLACED ONLY WITH TYPES IDENTICAL TO THOSE IN THE ORIGINAL CIRCUIT. SPECIAL COMPONENTS ARE SHADED ON THE

SCHEMATIC FOR EASY IDENTIFICATION. THIS CIRCUIT DIAGRAM MAY OCCASIONALLY DIFFER FROM THE ACTUAL CIRCUIT USED. THIS WAY, IMPLEMENTATION OF THE LATEST SAFETY AND PERFORMANCE IMPROVEMENT CHANGES INTO THE SET IS NOT DELAYED UNTIL THE NEW SERVICE LITERATURE IS PRINTED.

### NOTE :

1. Shaded (■) parts are critical for safety. Replace only with specified part number.
2. Voltages are DC-measured with a digital voltmeter during Play mode.

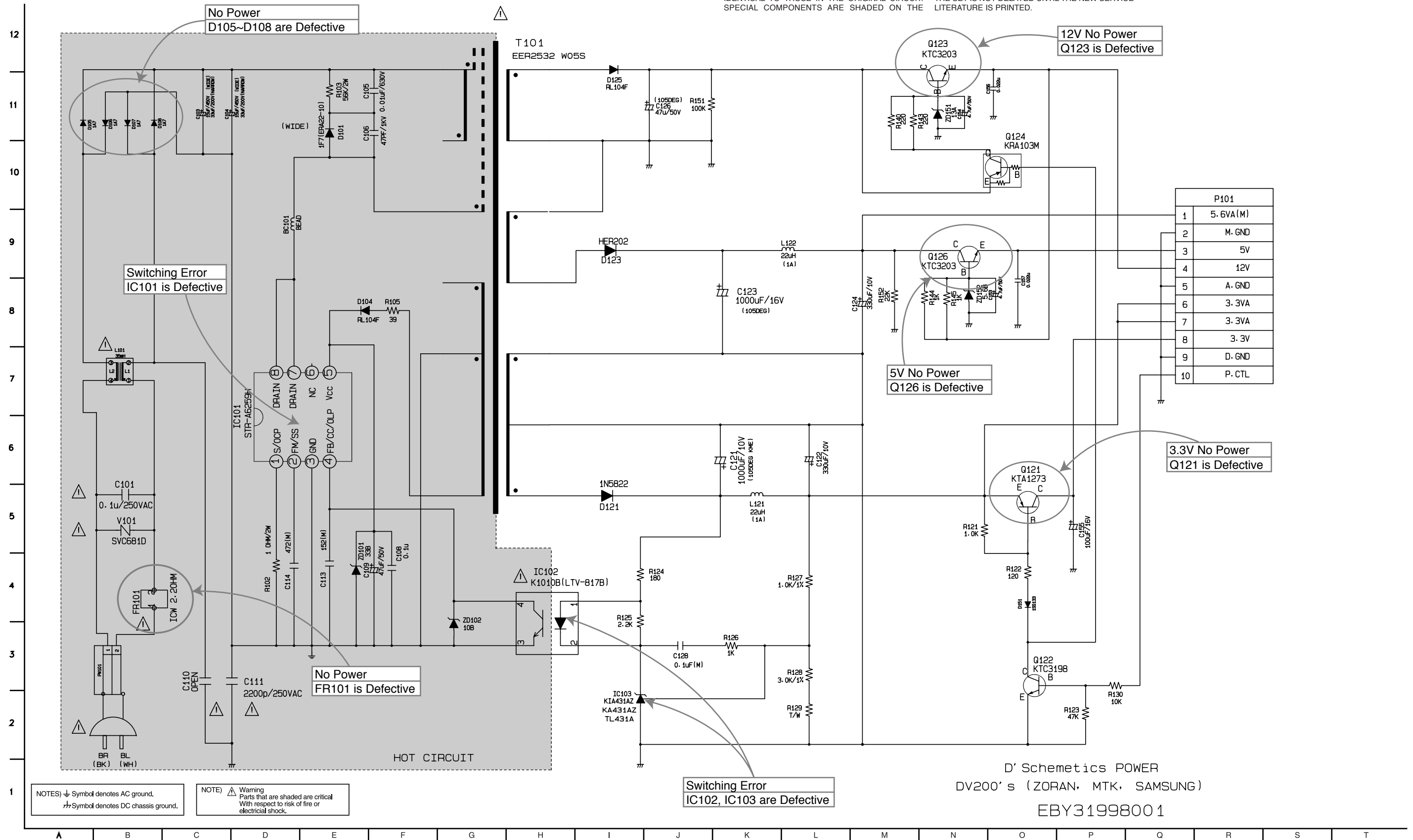

## 2. SYSTEM (MPEG) CIRCUIT DIAGRAM

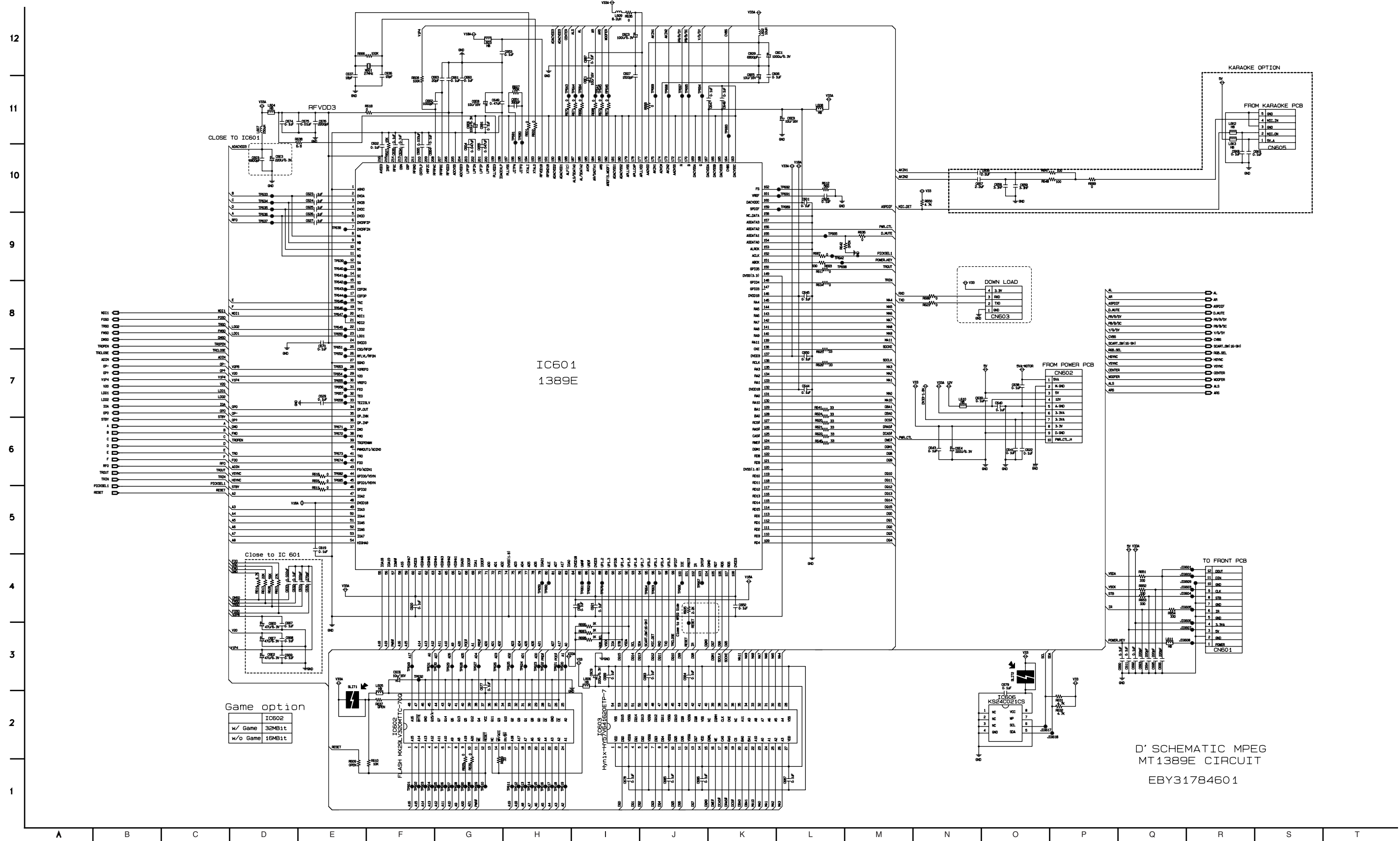

D' SCHEMATIC MPEG  
MT1389E CIRCUIT  
EBY31784601

### 3. SERVO CIRCUIT DIAGRAM

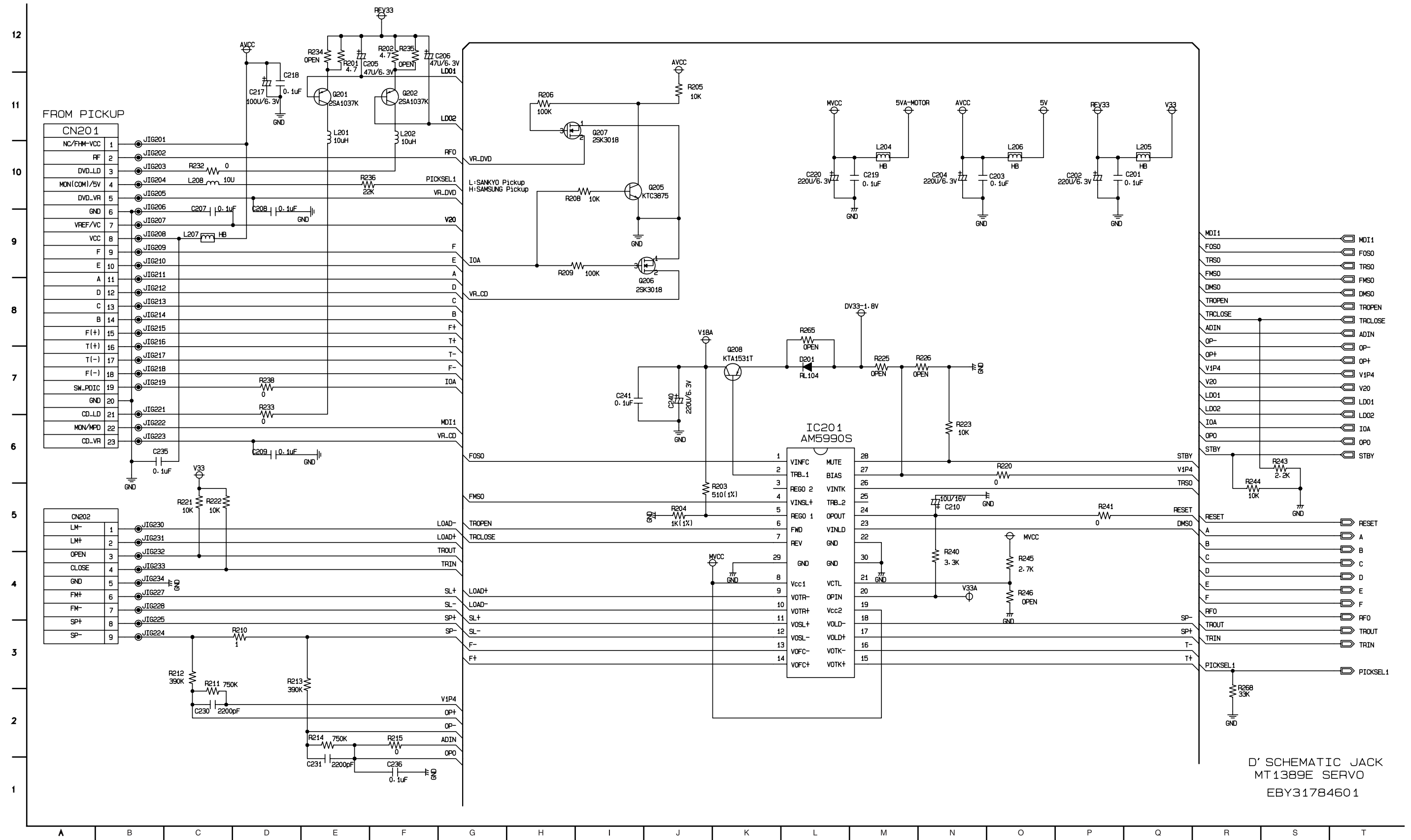

D' SCHEMATIC JACK  
MT1389E SERVO  
EBY31784601

# 4. AV/JACK CIRCUIT DIAGRAM

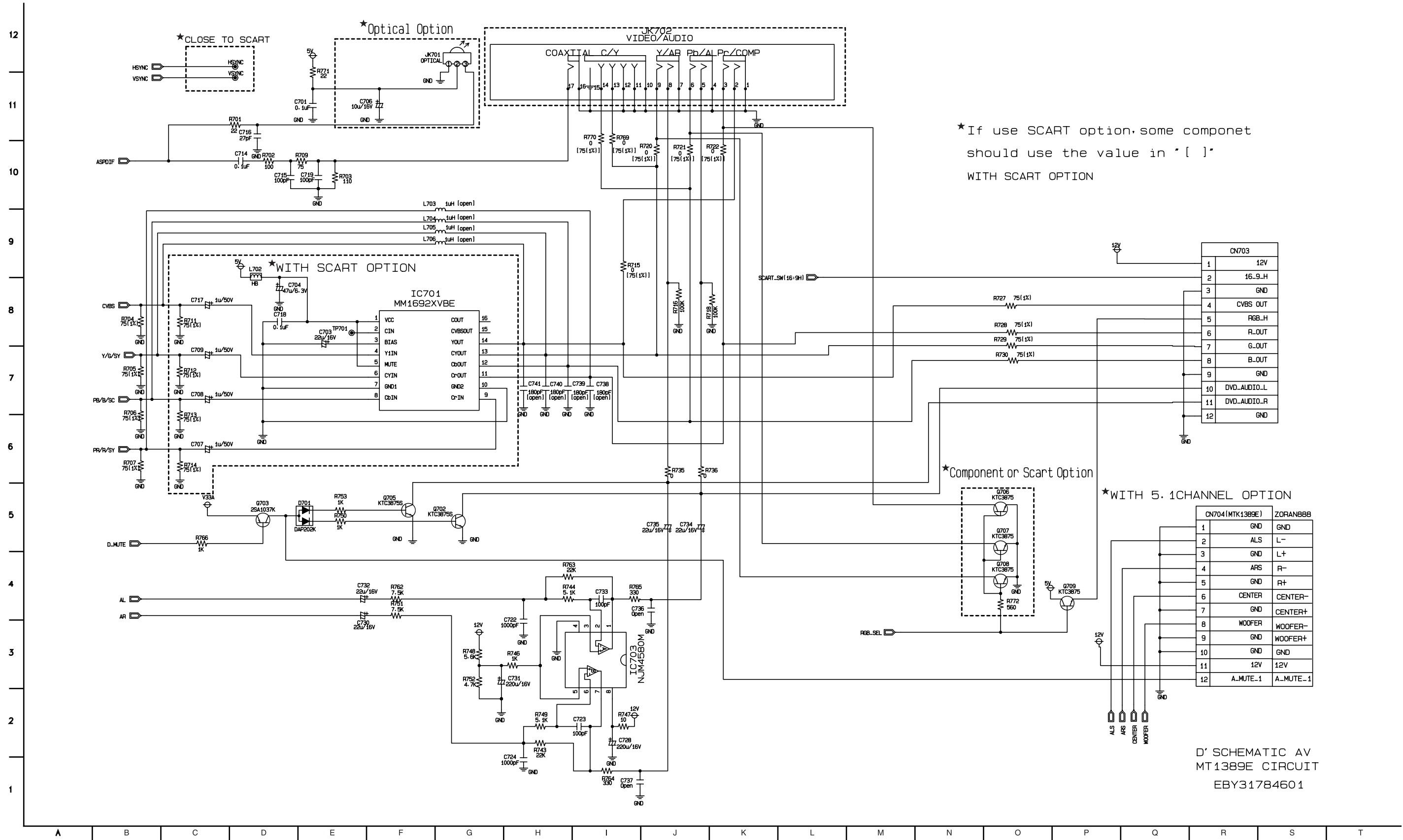

\*If use SCART option, some componet should use the value in '[ ]' WITH SCART OPTION

\*Component or Scart Option  
\*WITH 5.1CHANNEL OPTION

D' SCHEMATIC AV MT1389E CIRCUIT EBY31784601

# 5. KARAOKE & USB CIRCUIT DIAGRAM (8 & 9 TOOL)

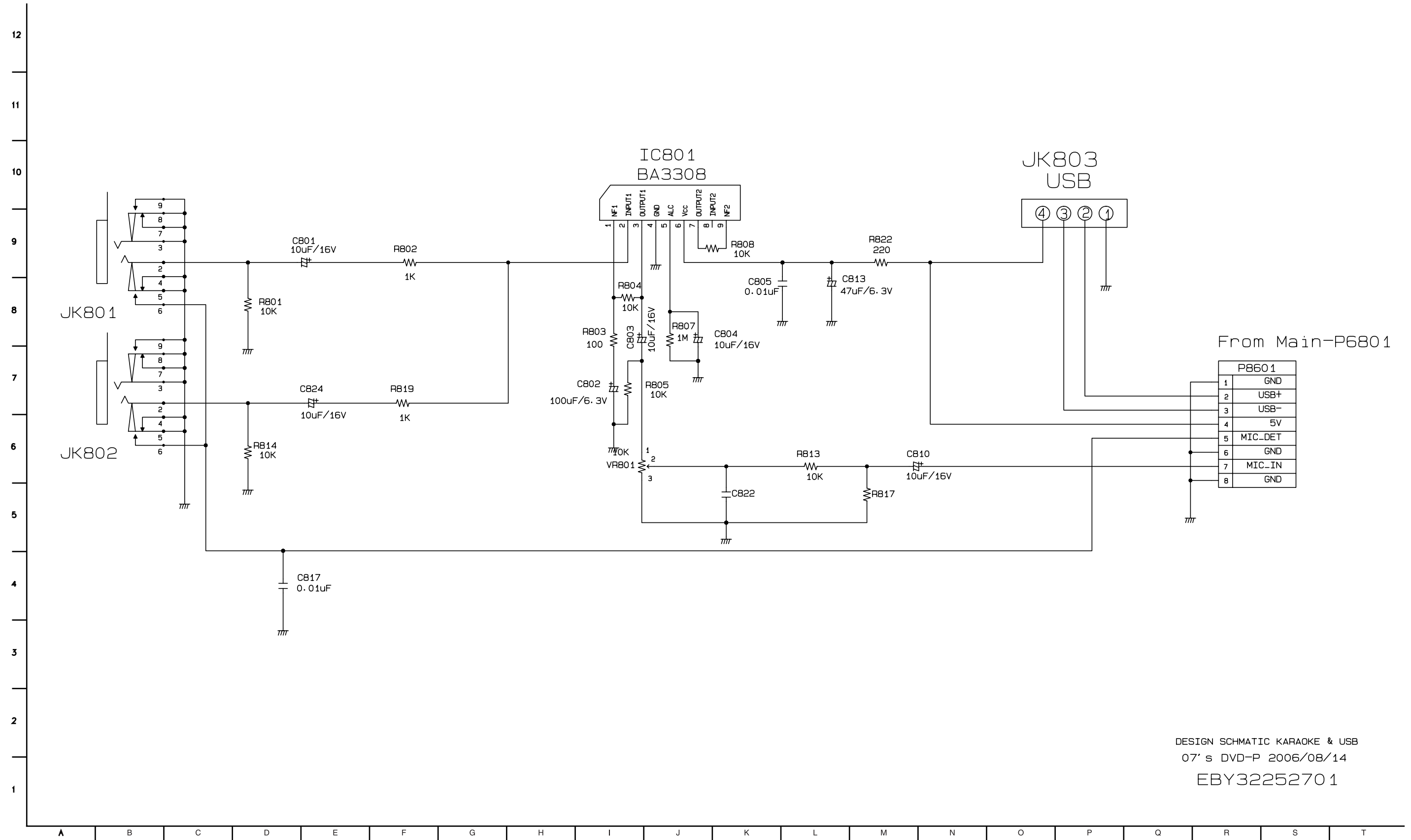

DESIGN SCHMATIC KARAOKE & USB  
07' s DVD-P 2006/08/14

EBY32252701



# 6. TIMER/KEY CIRCUIT DIAGRAM (4 & 7 TOOL)

DV200 4TOOL/7TOOL

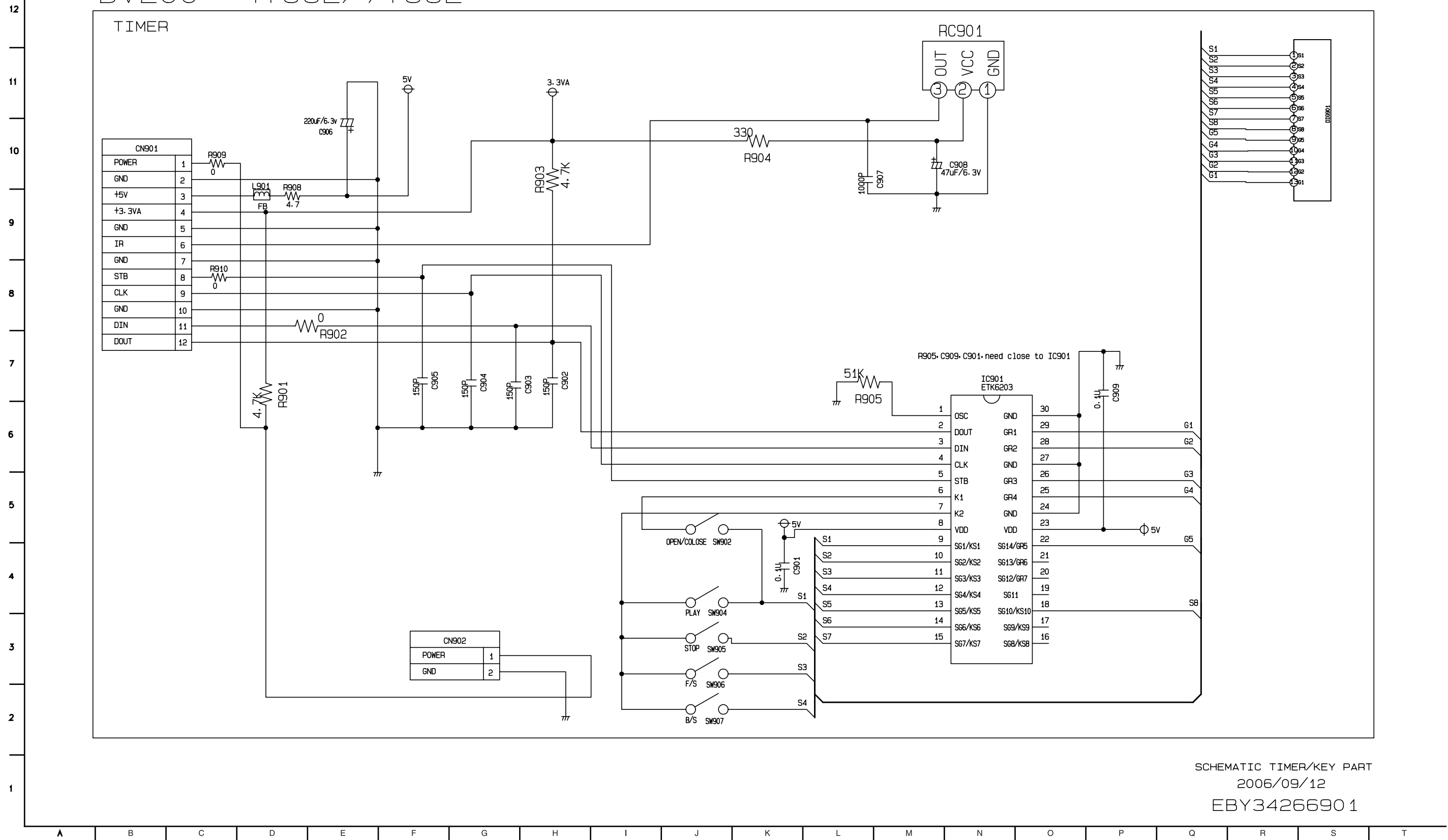

SCHMATIC TIMER/KEY PART  
2006/09/12  
EBY3426690 1

# 7. TIMER/KEY CIRCUIT DIAGRAM (5 TOOL)

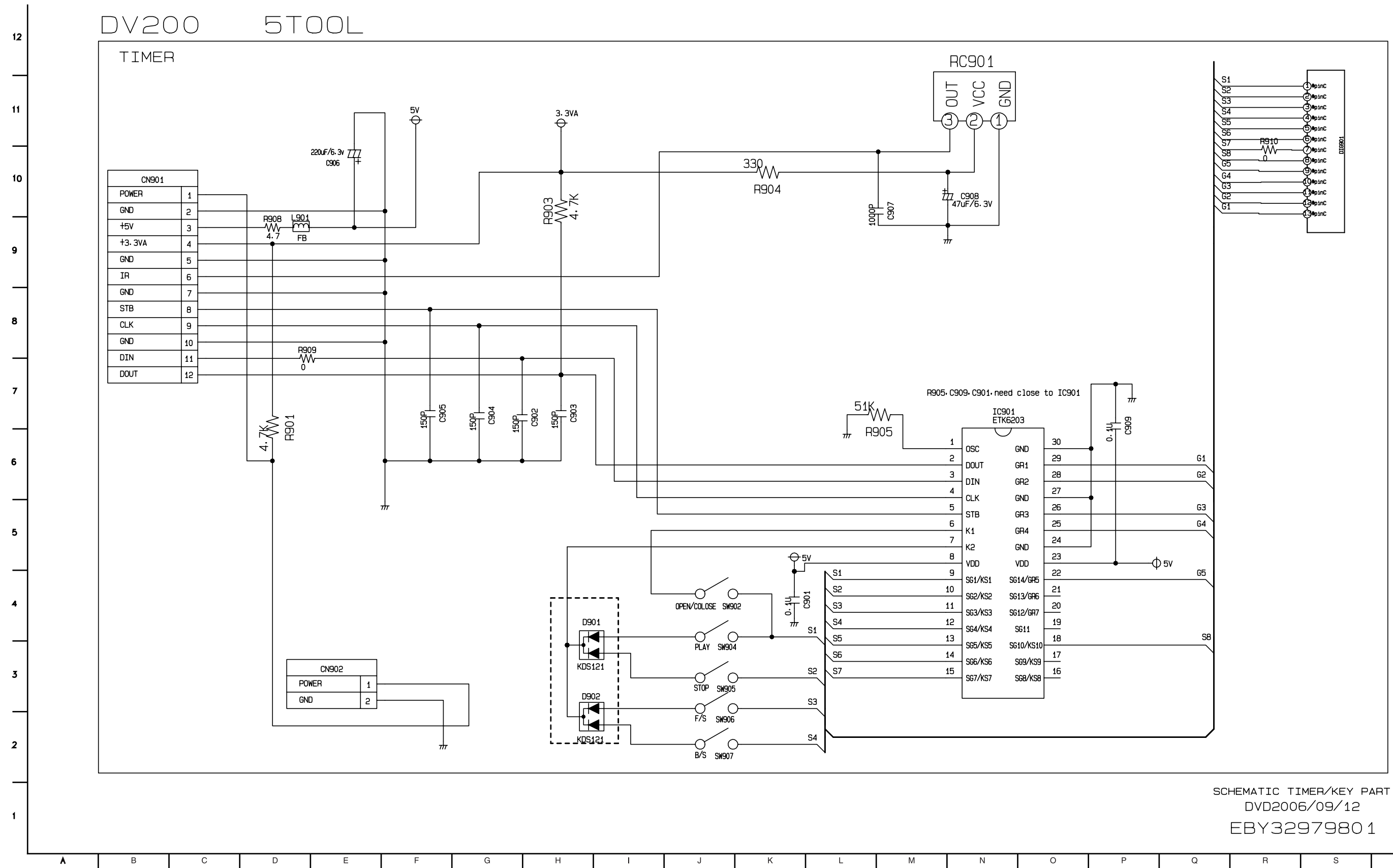

SCHEMATIC TIMER/KEY PART  
 DVD2006/09/12  
 EBY3297980 1

# 8. TIMER/KEY CIRCUIT DIAGRAM (8 TOOL)

DV200 8TOOL

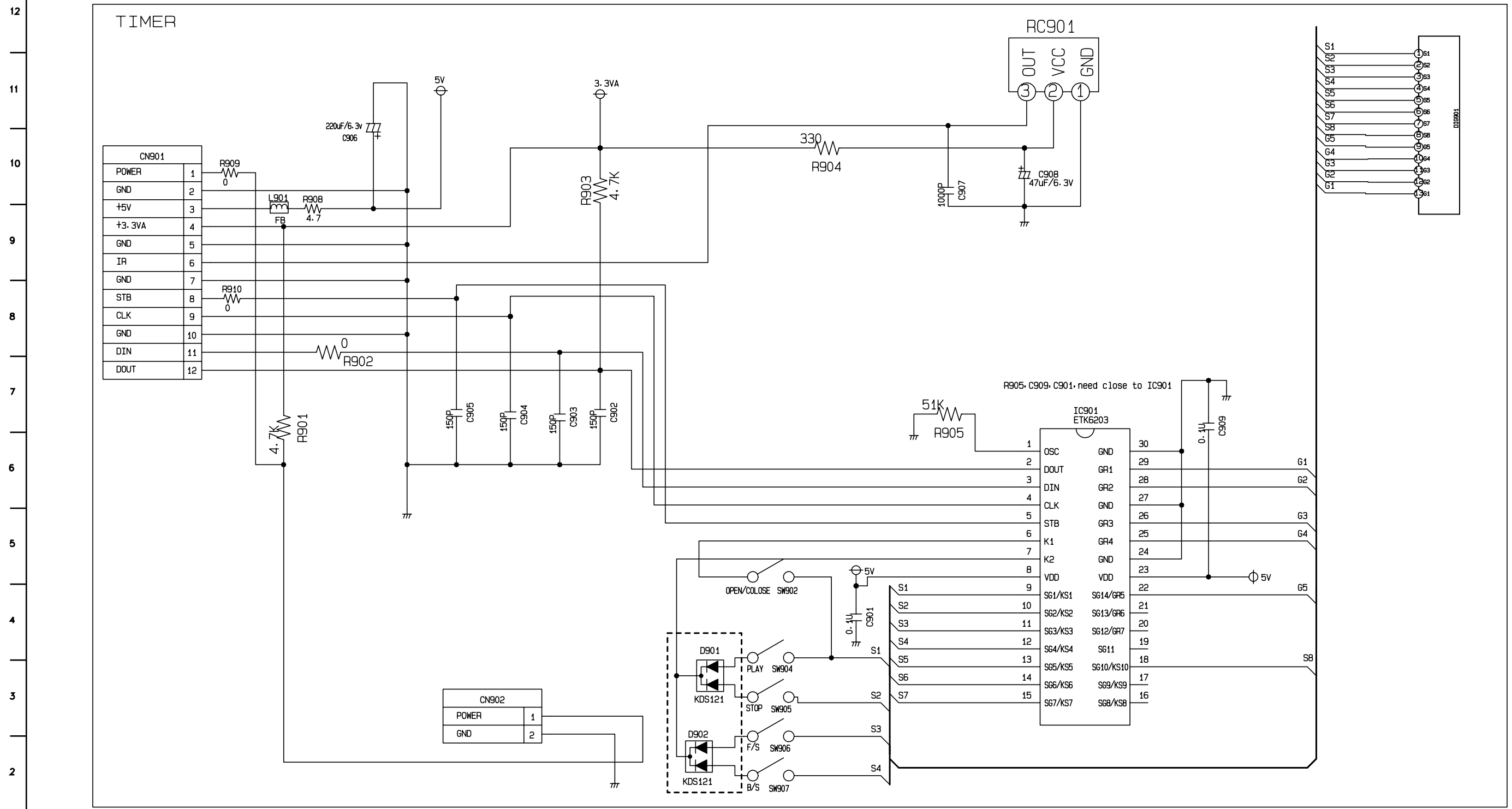

SCHEMATIC TIMER/KEY PART  
2006/08/18  
EBY32982201

# 9. TIMER/KEY CIRCUIT DIAGRAM (9 TOOL)

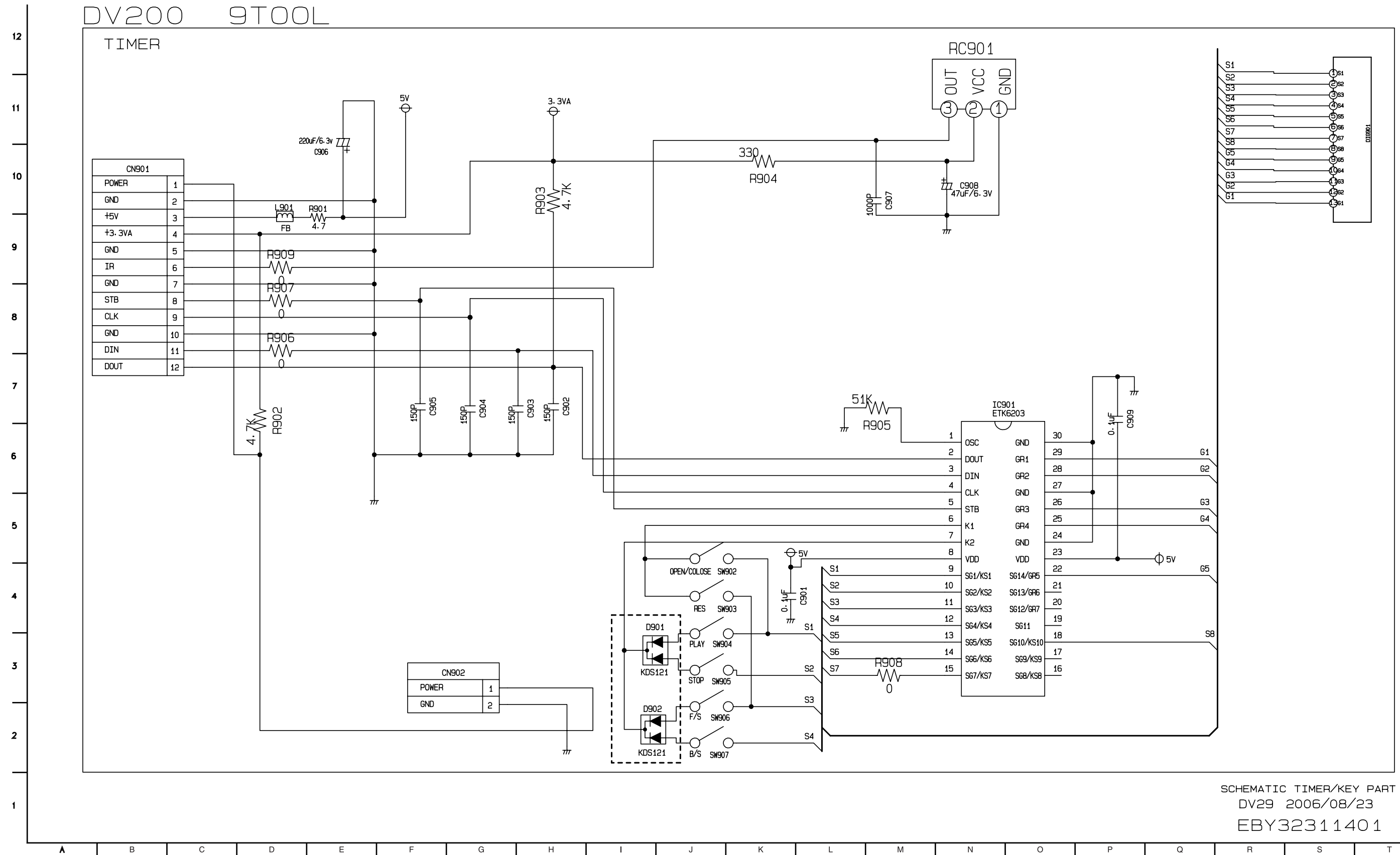

SCHMATIC TIMER/KEY PART  
DV29 2006/08/23  
EBY32311401





**2. KEY P.C.BOARD  
(4 TOOL)**

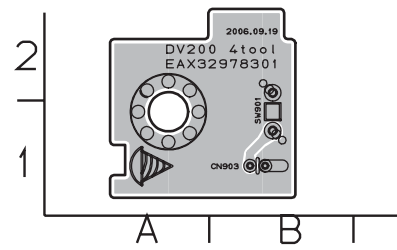

**(5 TOOL)**

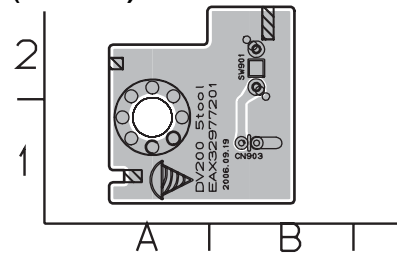

**(7 TOOL)**

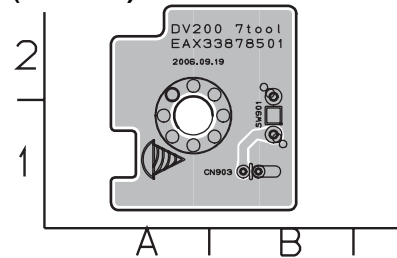

**(8 TOOL)**

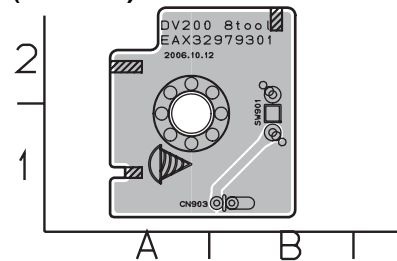

**(9 TOOL)**

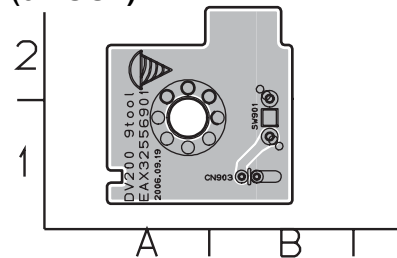

**3. TIMER P.C.BOARD  
(4 TOOL)**

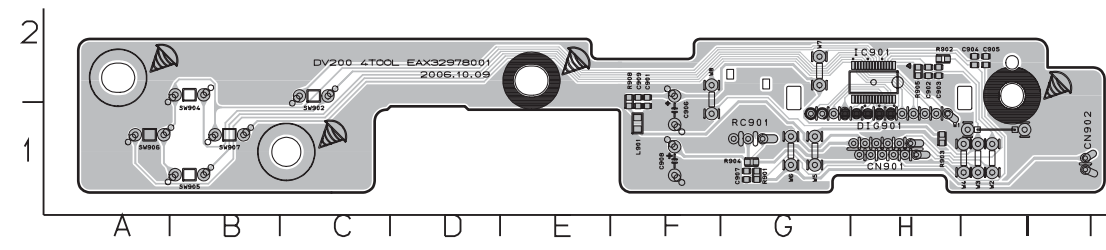

**(5 TOOL)**

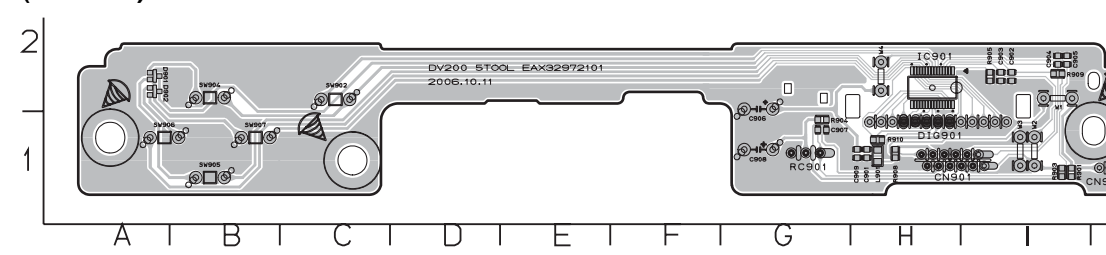

**(7 TOOL)**

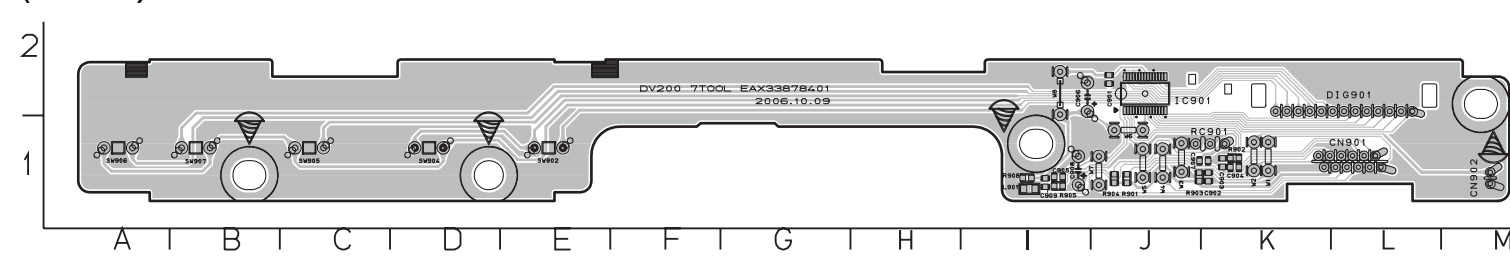

**(8 TOOL)**

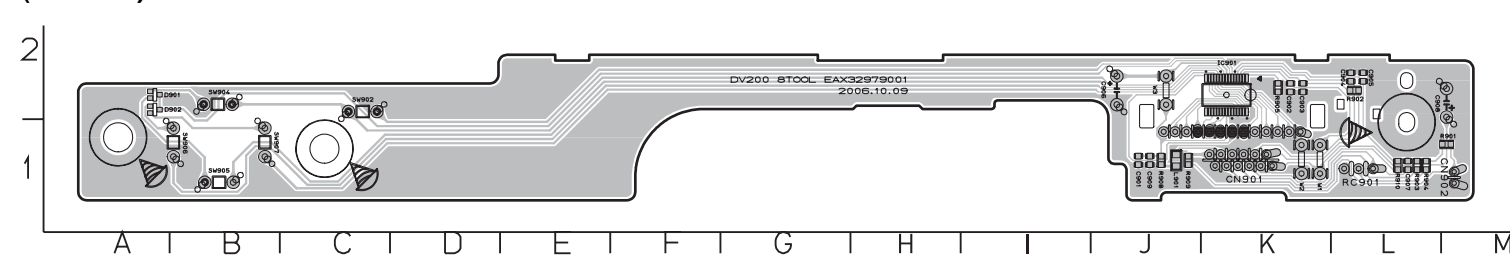

**(9 TOOL)**

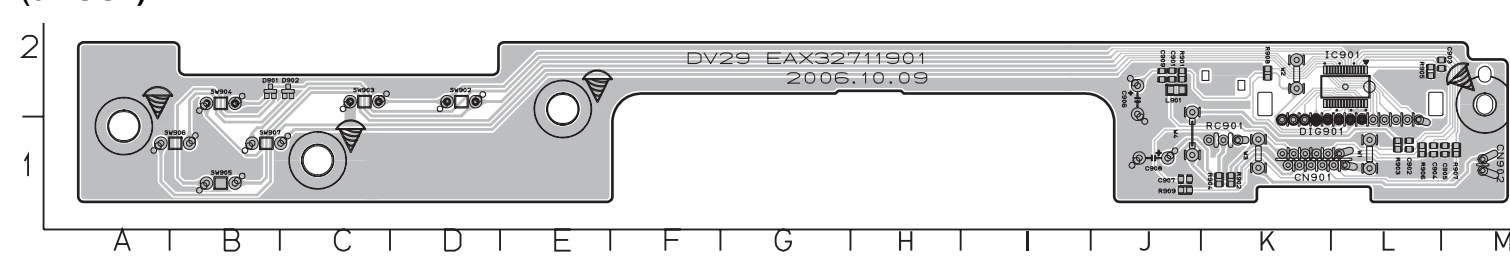

**4. KARAOKE P.C.BOARD (KARAOKE MODEL ONLY)  
(4 TOOL)**

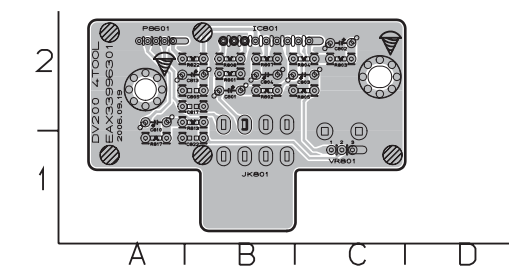

**(5 TOOL)**

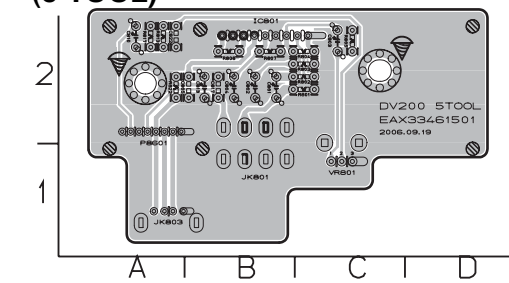

**(7 TOOL)**

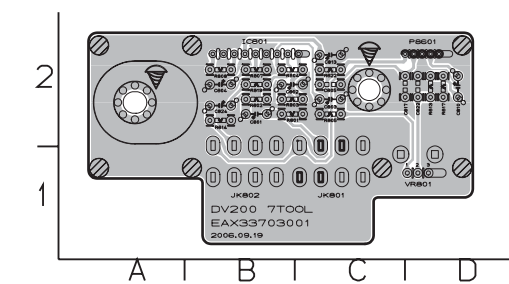

**(8 TOOL)**

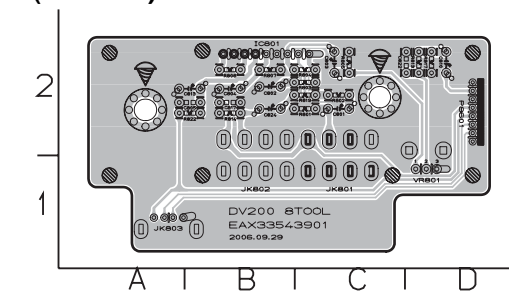

**(9 TOOL, WITHOUT)**





# MEMO

A series of horizontal dotted lines for writing.

# MEMO

A series of horizontal dotted lines for writing.

# SECTION 4

## MECHANISM (DP-11)

### CONTENTS

#### DECK MECHANISM PARTS LOCATIONS

• TOP VIEW.....	4-2
• TOP VIEW (WITHOUT TRAY DISC).....	4-2
• BOTTOM VIEW .....	4-2

#### DECK MECHANISM DISASSEMBLY

1. MAIN BASE .....	4-3
1-1. Clamp Assembly Disc .....	4-3
1-1-1. Plate Clamp .....	4-3
1-1-2. Magnet Clamp .....	4-3
1-1-3. Clamp Upper .....	4-3
2. TRAY DISC .....	4-3
3. BASE ASSEMBLY SLED .....	4-4
3-1. Gear Feed.....	4-4
3-2. Gear Middle .....	4-4
3-3. Gear Rack.....	4-4
4. RUBBER REAR.....	4-4
5. FRAME ASSEMBLY UP/DOWN.....	4-5
6. BELT LOADING.....	4-5
7. GEAR PULLEY.....	4-5
8. GEAR LOADING .....	4-5
9. GUIDE UP/DOWN .....	4-5
10. PWB ASSEMBLY LOADING.....	4-5
11. BASE MAIN .....	4-5

#### EXPLODED VIEW

1. DECK MECHANISM EXPLODED VIEW.....	4-7
--------------------------------------	-----

# DECK MECHANISM PARTS LOCATION

## • TOP VIEW (WITHOUT TRAY)

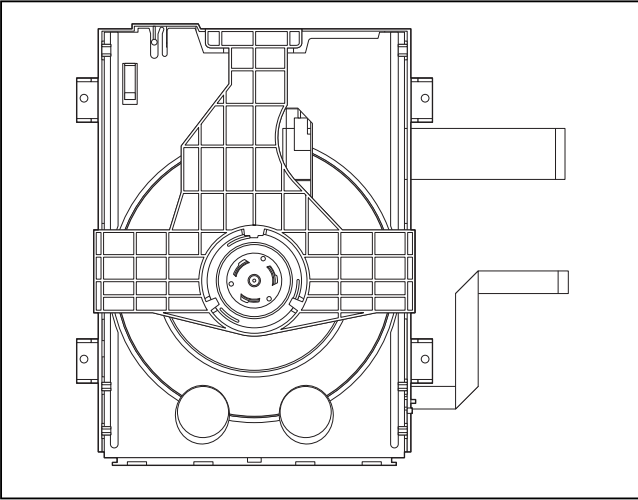

## • TOP VIEW (WITH TRAY)

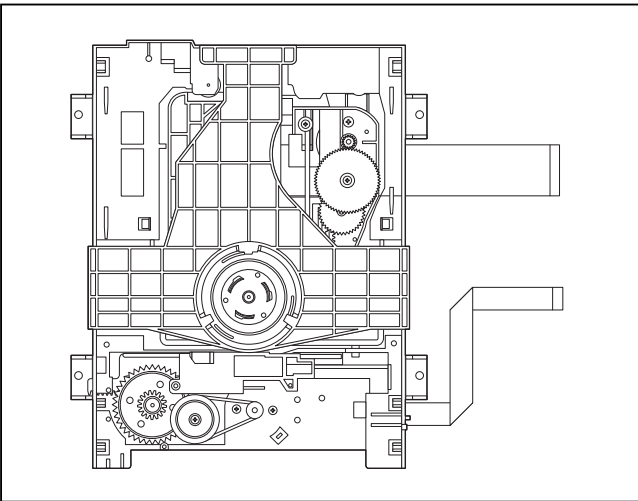

## • BOTTOM VIEW

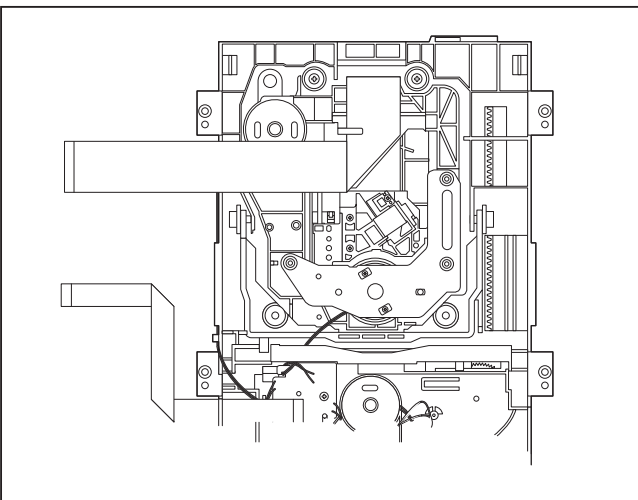

Procedure Starting No.	Parts	Fixing Type	Disassembly	Figure
1	Main Base			4-1
1	2 Clamp Assembly Disc			4-1
1, 2	3 Plate Clamp			4-1
1, 2, 3	4 Magnet Clamp			4-1
1, 2, 3, 4	5 Clamp Upper			4-1
1	6 Tray Disc			4-2
1, 6	7 Base Assembly Sled			4-3
1, 2, 6	8 Gear Feed	4 Screws, 1 Connector 1 Locking Tabs		4-3
1, 2, 6, 8	9 Gear Middle			
1, 2, 6, 8, 9	10 Gear Rack	1 Screw		4-3
1, 2, 7	11 Rubber Rear			4-3
1, 2, 7	12 Frame Assembly Up/Down	1 Screw	Bottom	4-4
1, 2	13 Belt Loading	1 Locking Tab		4-4
1, 2, 13	14 Gear Pulley			4-4
1, 2, 13, 14	15 Gear Loading	1 Locking Tab		4-4
1, 2, 7, 12, 13, 14	16 Guide Up/Down			4-4
1, 2, 13	17 PWB Assembly Loading	1 Locking Tab 1 Hook 2Screw	Bottom	4-4
1, 2, 7, 12, 13, 14, 15, 16, 17	18 Base Main	2 Locking Tabs		4-4

### Note

When reassembling, perform the procedure in reverse order.

The "Bottom" on Disassembly column of above Table indicates the part should be disassembled at the Bottom side.

# DECK MECHANISM DISASSEMBLY

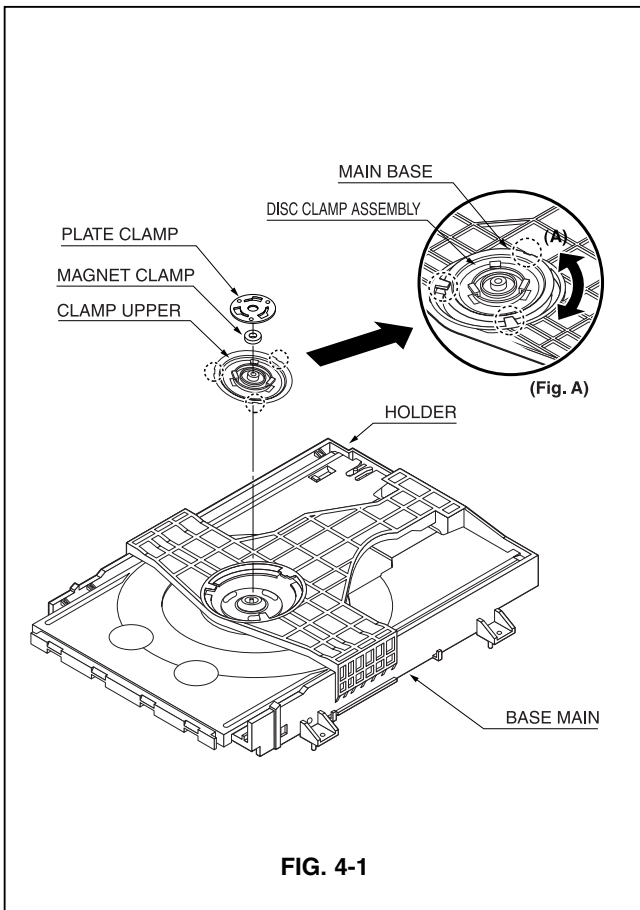

FIG. 4-1

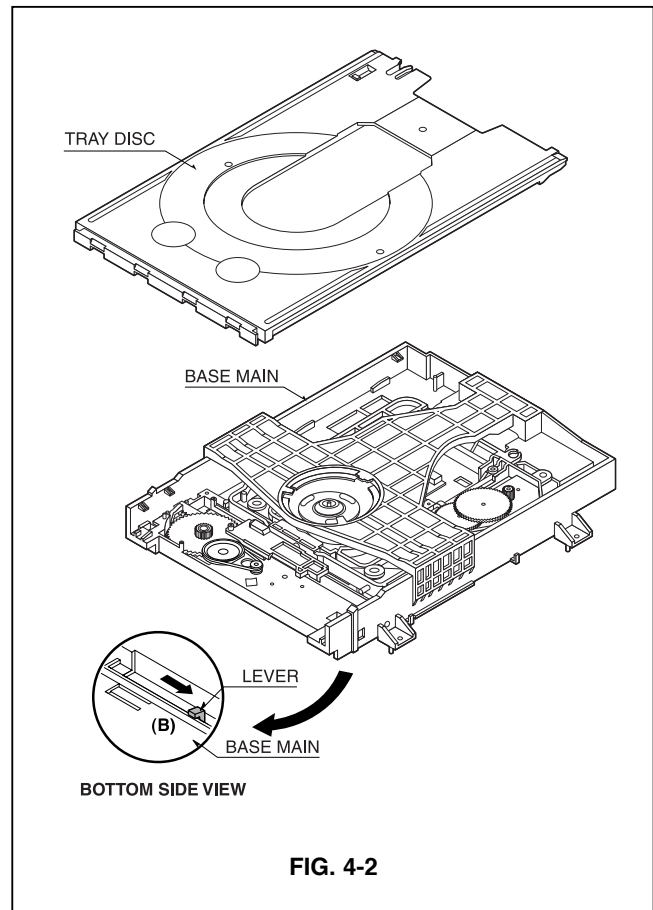

FIG. 4-2

## 1. MAIN BASE (FIG. 4-1)

### 1-1. Clamp Assembly Disc

- 1) Place the Clamp Assembly Disc as Fig. (A)
- 2) Lift up the Clamp Assembly Disc in direction of arrow(A).
- 3) Separate the Clamp Assembly Disc from the Holder Clamp.

### 1-1-1. Plate Clamp

- 1) Turn the Plate Clamp to counterclockwise direction and then lift up the Plate Clamp.

### 1-1-2. Magnet Clamp

### 1-1-3. Clamp Upper

## 2. TRAY DISC (FIG. 4-2)

- 1) Insert and push a Driver in the emergency eject hole(A) at the right side, or put the Driver on the Lever(B) of the Gear Emergency and pull the Lever(B) in direction of arrow so that the Tray Disc is ejected about 15~20mm.
- 2) Pull the Tray Disc until it is separated from the Base Main completely.

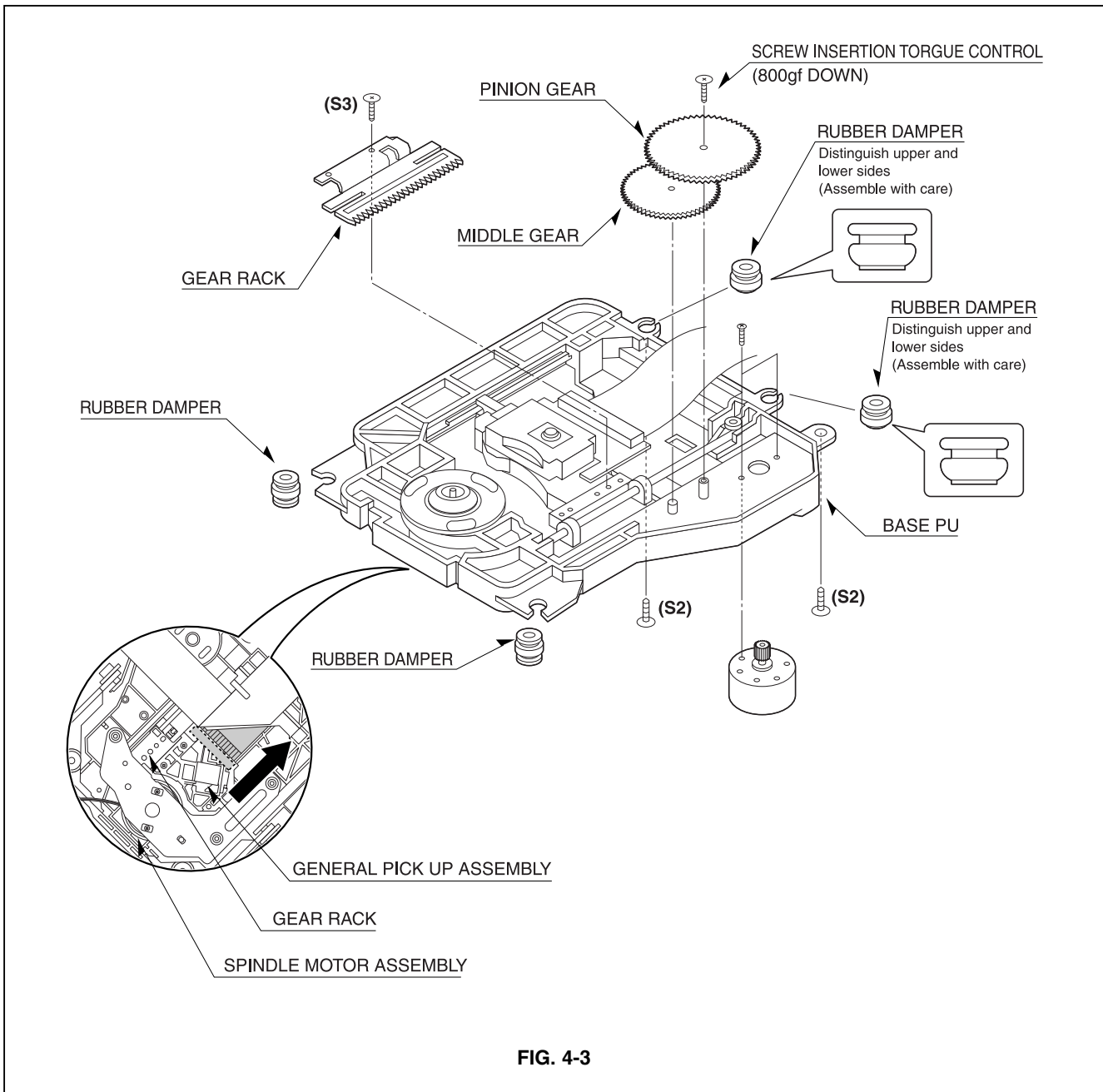

FIG. 4-3

**3. BASE ASSEMBLY SLED (FIG. 4-3)**

- 1) Release 4 Screw (S2).
- 2) Disconnect the FFC Connector (C1)

- 3-1. Gear Feed**
- 3-2. Gear Middle**

**3-3. Gear Rack**

- 1) Release the Scerw (S3)

**4. RUBBER REAR (FIG. 4-3)**

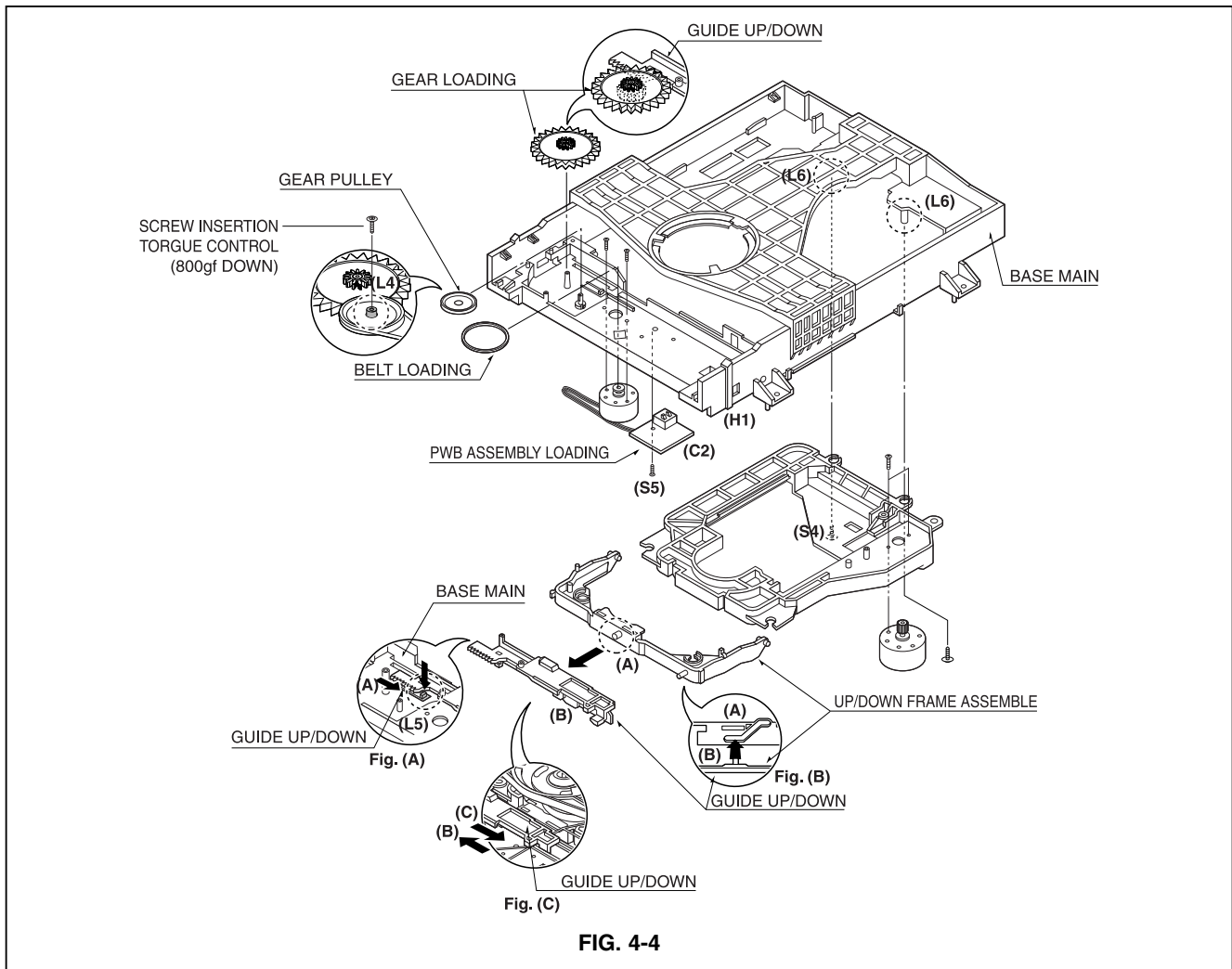

FIG. 4-4

## 5. FRAME ASSEMBLY UP/DOWN (FIG. 4-4)

### Note

Put the Base Main face down (Bottom Side)

- 1) Release the screw (S4)
- 2) Unlock the Locking Tab (L3) in direction of arrow and then lift up the Frame Assembly Up/Down to separate it from the Base Main.

### Note

- When reassembling move the Guide Up/Down in direction of arrow(C) until it is positioned as Fig.(C).
- When reassembling insert (A) portion of the Frame Assembly Up/Down in the (B) portion of the Guide Up/Down as Fig.(B)

## 6. BELT LOADING(FIG. 4-4)

### Note

Put the Base Main on original position(Top Side)

## 7. GEAR PULLEY (FIG. 4-4)

- 1) Unlock the Locking Tab(L4) in direction of arrow(B) and then separate the Gear Pulley from the Base Main

## 8. GEAR LOADING (FIG. 4-4)

## 9. GUIDE UP/DOWN (FIG. 4-4)

- 1) Move the Guide Up/Down in direction of arrow(A) as Fig.(A)
- 2) Push the Locking Tab(L5) down and then lift up the Guide Up/Down to separate it from the Base Main.

### Note

When reassembling place the Guide Up/Down as Fig.(C) and move it in direction arrow(B) until it is locked by the Locking Tab(L5). And confirm the Guide Up/Down as Fig.(A)

## 10. PWB ASSEMBLY LOADING (FIG. 4-4)

### Note

Put the Base Main face down(Bottom Side)

- 1) Release 1 Screws(S5)
- 2) Unlock the Loading Motor (C2) from the Hook (H1) on the Base Main.
- 3) Unlock 2 Locking Tabs(L6) and separate the PWB Assembly Loading from the Base Main.

## 11. BASE MAIN (FIG. 4-4)



# EXPLODED VIEW

## 1. DECK MECHANISM EXPLODED VIEW DP-11

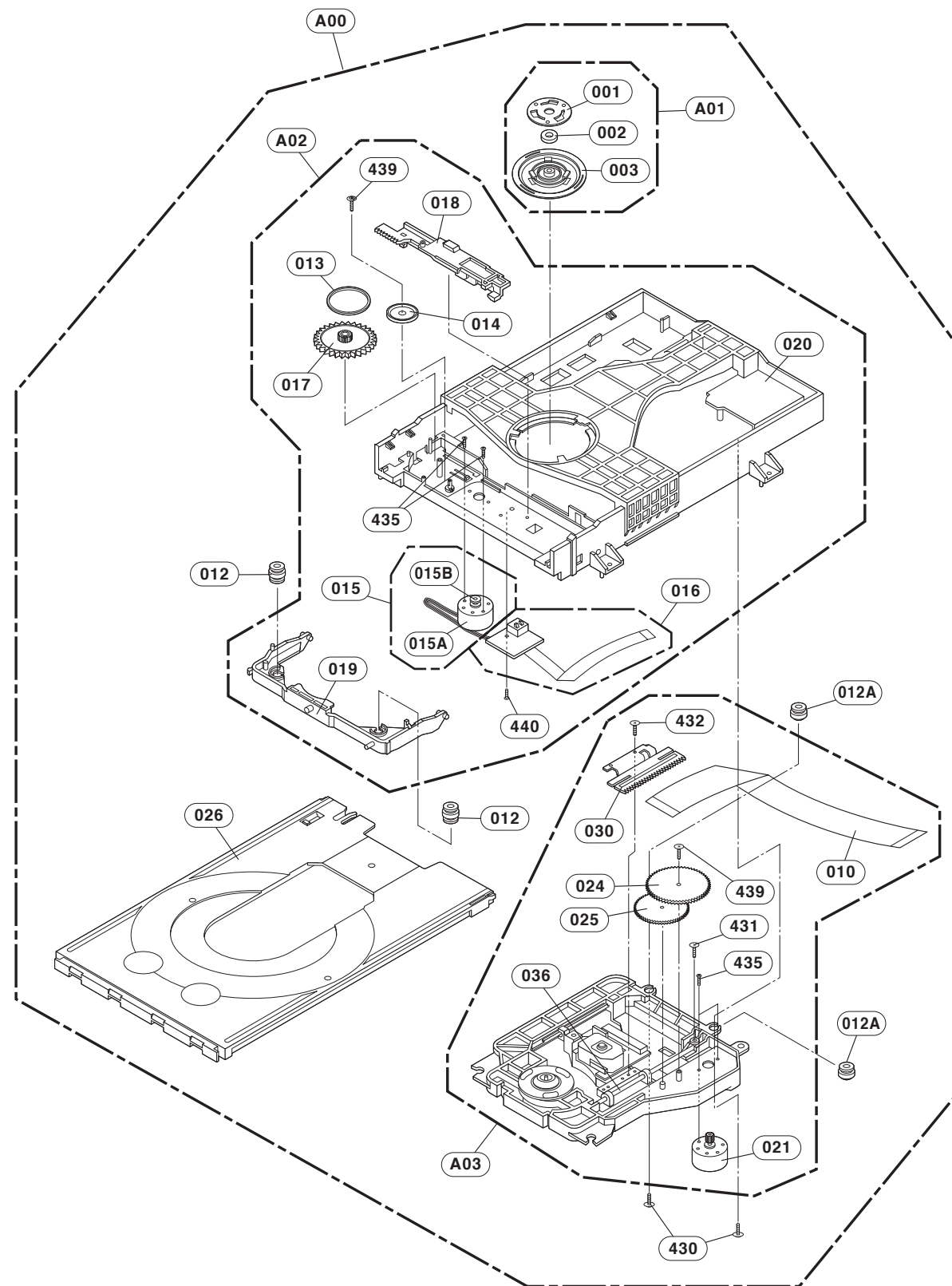



# MEMO

A series of horizontal dotted lines for writing a memo.

# MEMO

A series of horizontal dotted lines for writing a memo.