



SERVICE MANUAL

MODEL: DK867/DK855/DK854/DV840

DVD-VIDEO PLAYER

SERVICE MANUAL

MODEL: DK867/DK855/DK854/DV840

CAUTION

BEFORE SERVICING THE UNIT, READ THE "SAFETY PRECAUTIONS"
IN THIS MANUAL.

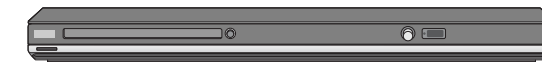

CONTENTS

SECTION 1.....SUMMARY

SECTION 2.....CABINET & MAIN CHASSIS

SECTION 3.....ELECTRICAL

SECTION 4.....MECHANISM (DP-12V)

SECTION 5.....REPLACEMENT PARTS LIST

SECTION 1

SUMMARY

CONTENTS

PRODUCT SAFETY SERVICING GUIDELINES FOR DVD PRODUCTS	1-3
SERVICING PRECAUTIONS	1-4
• GENERAL SERVICING PRECAUTIONS	
• INSULATION CHECKING PRODEDURE	
• ELECTROSTATICALLY SENSITIVE (ES) DEVICES	
THE PROCESS OF DISC DOWNLOAD	1-5
SPECIFICATIONS	1-7

PRODUCT SAFETY SERVICING GUIDELINES FOR DVD PRODUCTS

IMPORTANT SAFETY NOTICE

This manual was prepared for use only by properly trained audio-video service technicians.

When servicing this product, under no circumstances should the original design be modified or altered without permission from LG Corporation. All components should be replaced only with types identical to those in the original circuit and their physical location, wiring and lead dress must conform to original layout upon completion of repairs.

Special components are also used to prevent x-radiation, shock and fire hazard.

These components are indicated by the letter "X" included in their component designators and are required to maintain safe performance. No deviations are allowed without prior approval by LG Corporation.

Circuit diagrams may occasionally differ from the actual circuit used. This way, implementation of the latest safety and performance improvement changes into the set are not delayed until the new service literature is printed.

CAUTION: Do not attempt to modify this product in any way. Never perform customized installations without manufacturer's approval. Unauthorized modifications will not only void the warranty, but may lead to property damage or user injury.

Service work should be performed only after you are thoroughly familiar with these safety checks and servicing guidelines.

GRAPHIC SYMBOLS



The exclamation point within an equilateral triangle is intended to alert the service personnel to important safety information in the service literature.



The lightning flash with arrowhead symbol within an equilateral triangle is intended to alert the service personnel to the presence of noninsulated "dangerous voltage" that may be of sufficient magnitude to constitute a risk of electric shock.



The pictorial representation of a fuse and its rating within an equilateral triangle is intended to convey to the service personnel the following fuse replacement caution notice:

CAUTION: FOR CONTINUED PROTECTION AGAINST RISK OF FIRE, REPLACE ALL FUSES WITH THE SAME TYPE AND RATING AS MARKED NEAR EACH FUSE.

SERVICE INFORMATION

While servicing, use an isolation transformer for protection from AC line shock. After the original service problem has been corrected, make a check of the following:

FIRE AND SHOCK HAZARD

1. Be sure that all components are positioned to avoid a possibility of adjacent component shorts. This is especially important on items transported to and from the repair shop.
2. Verify that all protective devices such as insulators, barriers, covers, shields, strain reliefs, power supply cords, and other hardware have been reinstalled per the original design. Be sure that the safety purpose of the polarized line plug has not been defeated.
3. Soldering must be inspected to discover possible cold solder joints, solder splashes, or sharp solder points. Be certain to remove all loose foreign particles.
4. Check for physical evidence of damage or deterioration to parts and components, for frayed leads or damaged insulation (including the AC cord), and replace if necessary.
5. No lead or component should touch a high current device or a resistor rated at 1 watt or more. Lead tension around protruding metal surfaces must be avoided.
6. After reassembly of the set, always perform an AC leakage test on all exposed metallic parts of the cabinet (the channel selector knobs, antenna terminals, handle and screws) to be sure that set is safe to operate without danger of electrical shock. **DO NOT USE A LINE ISOLATION TRANSFORMER DURING THIS TEST.** Use an AC voltmeter having 5000 ohms per volt or more sensitivity in the following manner: Connect a 1500 ohm, 10 watt resistor, paralleled by a .15 mfd 150V AC type capacitor between a known good earth ground water pipe, conduit, etc.) and the exposed metallic parts, one at a time. Measure the AC voltage across the combination of 1500 ohm resistor and .15 mfd capacitor. Reverse the AC plug by using a non-polarized adaptor and repeat AC voltage measurements for each exposed metallic part. Voltage measured must not exceed 0.75 volts RMS. This corresponds to 0.5 milliamp AC. Any value exceeding this limit constitutes a potential shock hazard and must be corrected immediately.

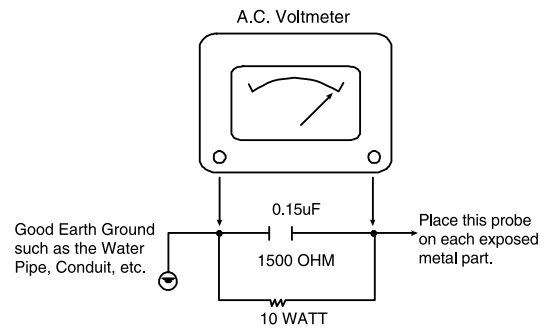

TIPS ON PROPER INSTALLATION

1. Never install any receiver in a closed-in recess, cubbyhole, or closely fitting shelf space over, or close to, a heat duct, or in the path of heated air flow.
2. Avoid conditions of high humidity such as: outdoor patio installations where dew is a factor, near steam radiators where steam leakage is a factor, etc.
3. Avoid placement where draperies may obstruct venting. The customer should also avoid the use of decorative scarves or other coverings that might obstruct ventilation.
4. Wall- and shelf-mounted installations using a commercial mounting kit must follow the factory-approved mounting instructions. A product mounted to a shelf or platform must retain its original feet (or the equivalent thickness in spacers) to provide adequate air flow across the bottom. Bolts or screws used for fasteners must not touch any parts or wiring. Perform leakage tests on customized installations.
5. Caution customers against mounting a product on a sloping shelf or in a tilted position, unless the receiver is properly secured.
6. A product on a roll-about cart should be stable in its mounting to the cart. Caution the customer on the hazards of trying to roll a cart with small casters across thresholds or deep pile carpets.
7. Caution customers against using extension cords. Explain that a forest of extensions, sprouting from a single outlet, can lead to disastrous consequences to home and family.

SERVICING PRECAUTIONS

CAUTION: Before servicing the DVD covered by this service data and its supplements and addends, read and follow the SAFETY PRECAUTIONS. NOTE: if unforeseen circumstances create conflict between the following servicing precautions and any of the safety precautions in this publication, always follow the safety precautions.

Remember Safety First :

General Servicing Precautions

1. Always unplug the DVD AC power cord from the AC power source before:
 - (1) Removing or reinstalling any component, circuit board, module, or any other assembly.
 - (2) Disconnecting or reconnecting any internal electrical plug or other electrical connection.
 - (3) Connecting a test substitute in parallel with an electrolytic capacitor.
Caution: A wrong part substitution or incorrect polarity installation of electrolytic capacitors may result in an explosion hazard.
2. Do not spray chemicals on or near this DVD or any of its assemblies.
3. Unless specified otherwise in this service data, clean electrical contacts by applying an appropriate contact cleaning solution to the contacts with a pipe cleaner, cotton-tipped swab, or comparable soft applicator.
Unless specified otherwise in this service data, lubrication of contacts is not required.
4. Do not defeat any plug/socket B+ voltage interlocks with which instruments covered by this service manual might be equipped.
5. Do not apply AC power to this DVD and / or any of its electrical assemblies unless all solid state device heat sinks are correctly installed.
6. Always connect the test instrument ground lead to an appropriate ground before connecting the test instrument positive lead. Always remove the test instrument ground lead last.

Insulation Checking Procedure

Disconnect the attachment plug from the AC outlet and turn the power on. Connect an insulation resistance meter (500V) to the blades of the attachment plug. The insulation resistance between each blade of the attachment plug and accessible conductive parts (Note 1) should be more than 1Mohm.

Note 1: Accessible Conductive Parts include Metal panels, Input terminals, Earphone jacks, etc.

Electrostatically Sensitive (ES) Devices

Some semiconductor (solid state) devices can be damaged easily by static electricity. Such components commonly are called Electrostatically Sensitive (ES) Devices. Examples of typical ES devices are integrated circuits and some field effect transistors and semiconductor chip components.

The following techniques should be used to help reduce the incidence of component damage caused by static electricity.

1. Immediately before handling any semiconductor component or semiconductor-equipped assembly, drain off any electrostatic charge on your body by touching a known earth ground. Alternatively, obtain and wear a commercially available discharging wrist strap device, which should be removed for potential shock reasons prior to applying power to the unit under test.
2. After removing an electrical assembly equipped with ES devices, place the assembly on a conductive surface such as aluminum foil, to prevent electrostatic charge buildup or exposure of the assembly.
3. Use only a grounded-tip soldering iron to solder or unsolder ES devices.
4. Use only an anti-static solder removal device. Some solder removal devices not classified as "anti-static" can generate electrical charges sufficient to damage ES devices.
5. Do not use freon-propelled chemicals. These can generate an electrical charge sufficient to damage ES devices.
6. Do not remove a replacement ES device from its protective package until immediately before you are ready to install it. (Most replacement ES devices are packaged with leads electrically shorted together by conductive foam, aluminum foil, or comparable conductive material).
7. Immediately before removing the protective material from the leads of a replacement ES device, touch the protective material to the chassis or circuit assembly into which the device will be installed.

Caution: Be sure no power is applied to the chassis or circuit, and observe all other safety precautions.

8. Minimize bodily motions when handling unpackaged replacement ES devices. (Normally harmless motion such as the brushing together of your clothes fabric or the lifting of your foot from a carpeted floor can generate static electricity sufficient to damage an ES device.)

THE PROCESS OF DISC DOWNLOAD

Please follow the below process to download a program with disc

1. Turn on the DVD-player.
(Note. Be sure that there is no disc in DVD-player)
2. Press "SETUP" button on Remote control.
3. Choose a "**display**" menu by using the cursor button and then choose a "**TV Aspect**" menu. And choose "**16:9**" menu.

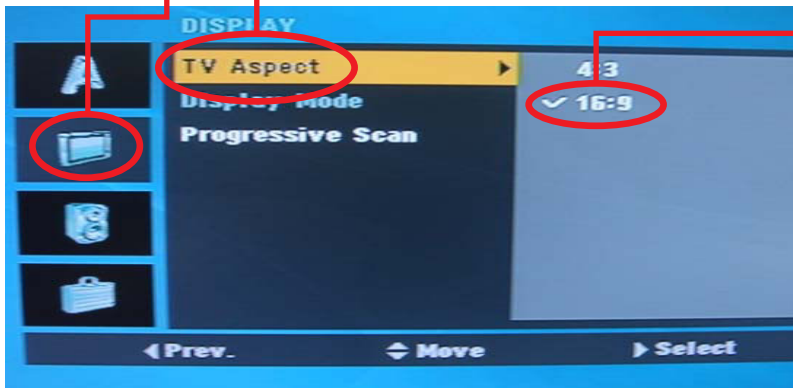

4. Press the 1 --> 3 --> 9 --> 7 --> 1 --> 3 --> 9(numerical button) --> Enter key on remote control to confirm the system information.
5. Remember or write the **model name**.

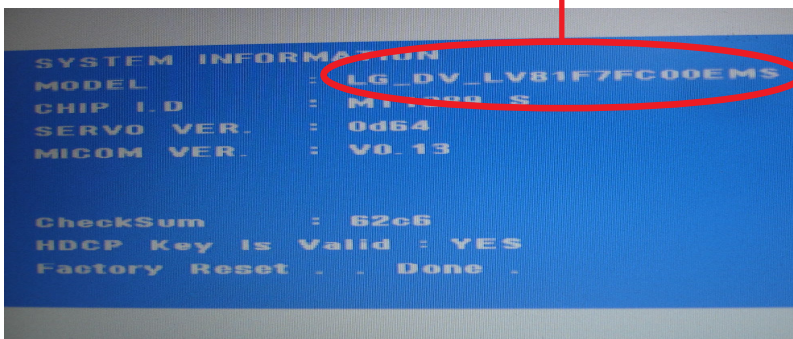

6. Change the program file name of new version to the model name
Ex> New ver. program file->LG_DV_LV80F7FC10EMSMIS_V014.ROM
Model name -> LG_DV_LV81F7FC00EMS
Change New ver. program file like this --> LG_DV_LV81F7FC00EMSMIS.ROM
(NOTICE) You must add "MIS" at the end of model name
If you don't change the file name like that, Disc download isn't be worked.

7. Copy the changed file to a disc.
8. Insert the copied disc to DVD-player.
9. If the below picture appears on the screen, Press “▲” key.

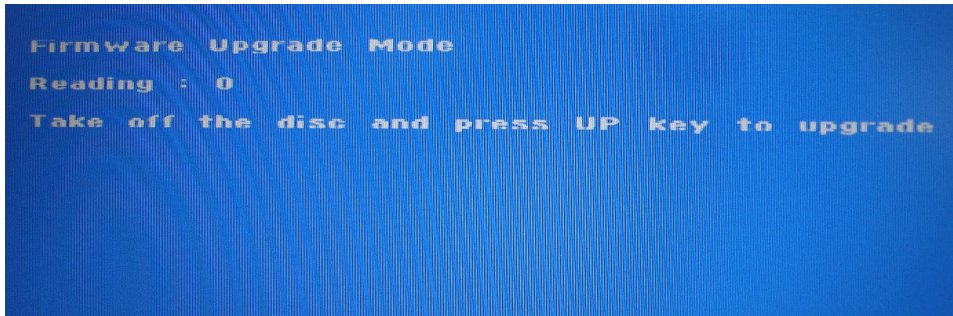

10. After the below picture appears on the screen, Disc will emerge from DVD-player automatically. Take the disc out of the DVD-player.

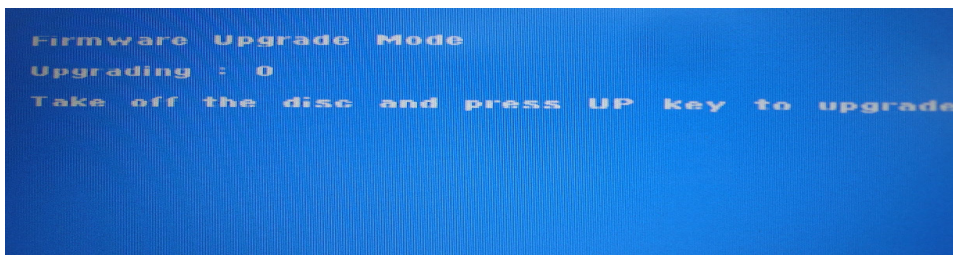

11. After Disc download is completed, DVD-player turns off and then turns on automatically.
12. Do it again the process 1, 2, 3, 4 to confirm the version.

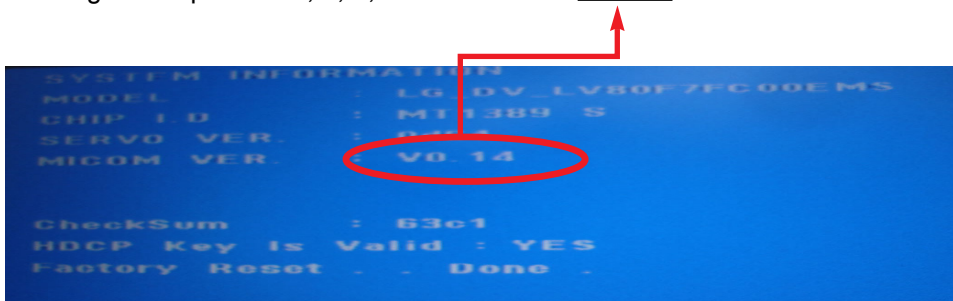

SPECIFICATIONS

• GENERAL

Power requirements	AC 110V ~ 240V, 50/60Hz
Power consumption	8W
Dimensions (Approx.)	360 x 35 x 195mm (W x H x D) without foot
Net Weight (Approx.)	2.3kg
Operating temperature:	5°C to 35°C
Operating humidity	5% to 90%
Laser	Semiconductor laser
Signal system	PAL / NTSC

• OUTPUTS

Video Output	1.0V (p-p), 75Ω, sync negative, RCA jack x 1
Component Video Output	(Y) 1.0V (p-p), 75Ω, sync negative, RCA jack x 1 (Pb)/(Pr) 0.7V (p-p), 75Ω, RCA jack x 2
Audio Output	2.0Vrms (1kHz, 0dB), 600Ω, RCA jack (L, R) x 1 /
Digital Output (Coaxial)	0.5V (p-p), 75Ω, RCA jack x 1

SECTION 2

CABINET & MAIN CHASSIS

CONTENTS

EXPLODED VIEWS	2-2
1. CABINET AND MAIN FRAME SECTION	2-2
2. DECK MECHANISM SECTION (DP-12V)	2-3
3. PACKING ACCESSORY SECTION.....	2-4

EXPLODED VIEWS

1. CABINET AND MAIN FRAME SECTION

5

4

3

2

1

NOTES) THE EXCLAMATION POINT WITHIN AN EQUILATERAL TRIANGLE IS INTENDED TO ALERT THE SERVICE PERSONNEL TO THE PRESENCE OF IMPORTANT SAFETY INFORMATION IN SERVICE LITERATURE.

★ **OPTIONAL PARTS**

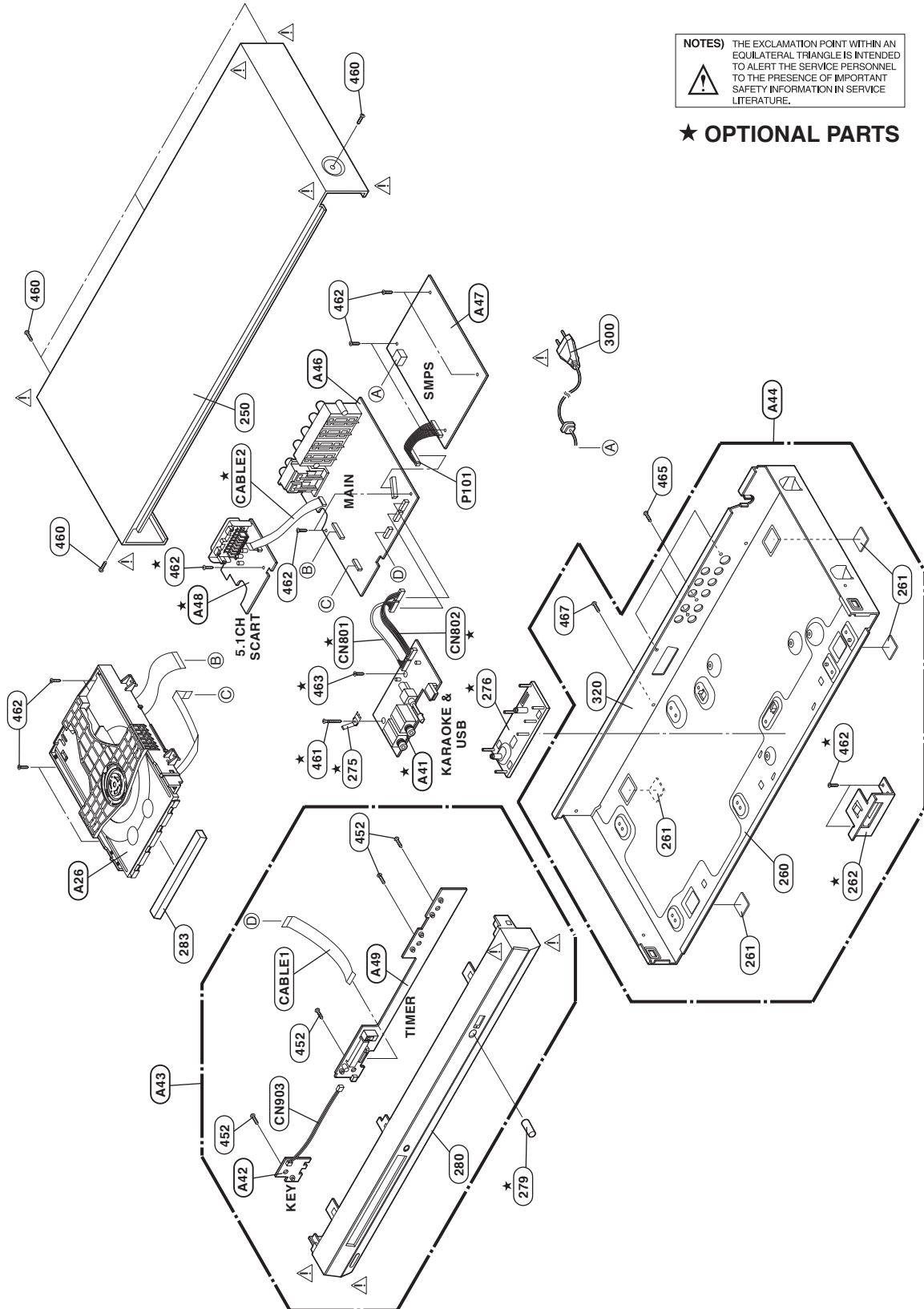

A

B

C

D

2. DECK MECHANISM SECTION (DP-12V)

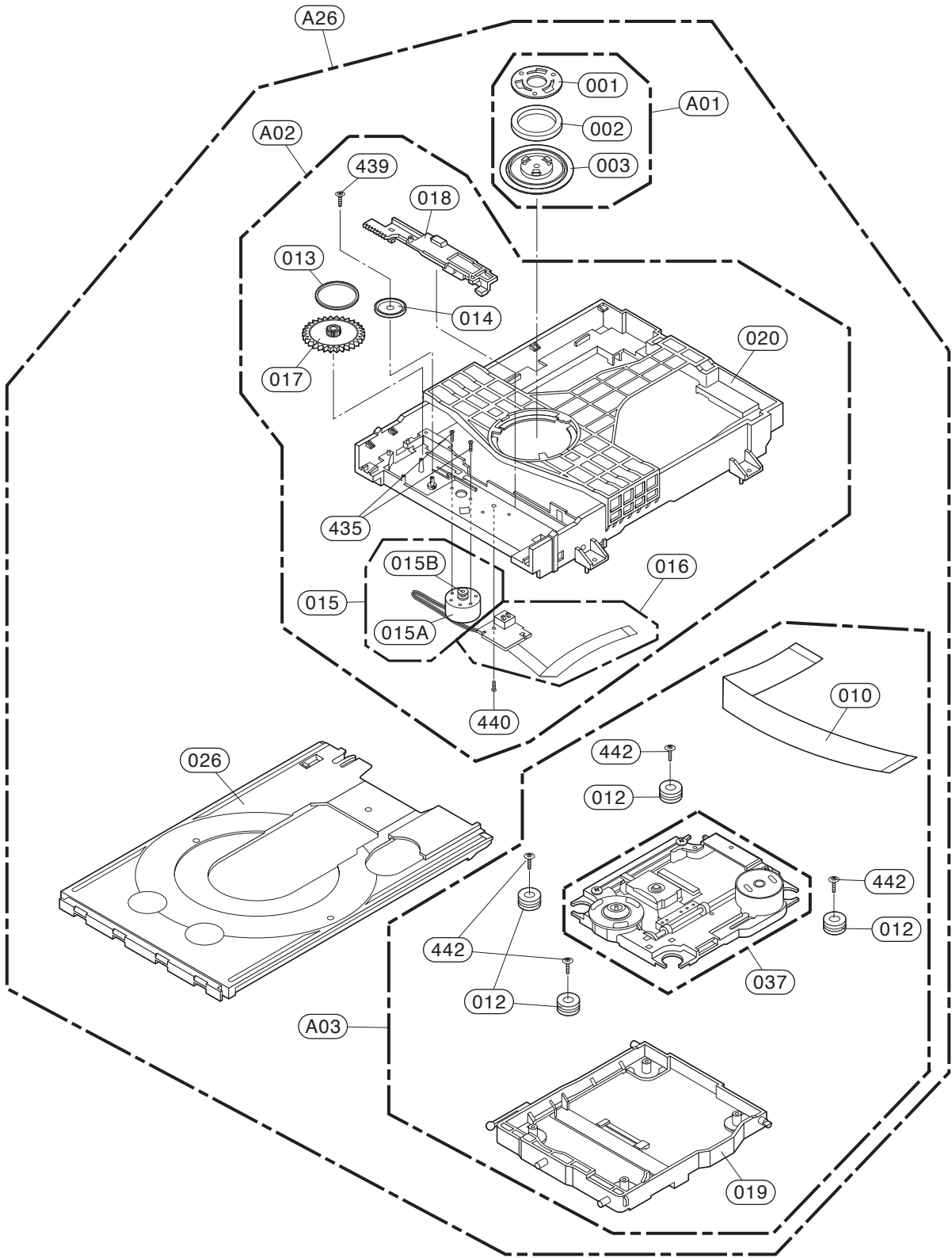

3. PACKING ACCESSORY SECTION

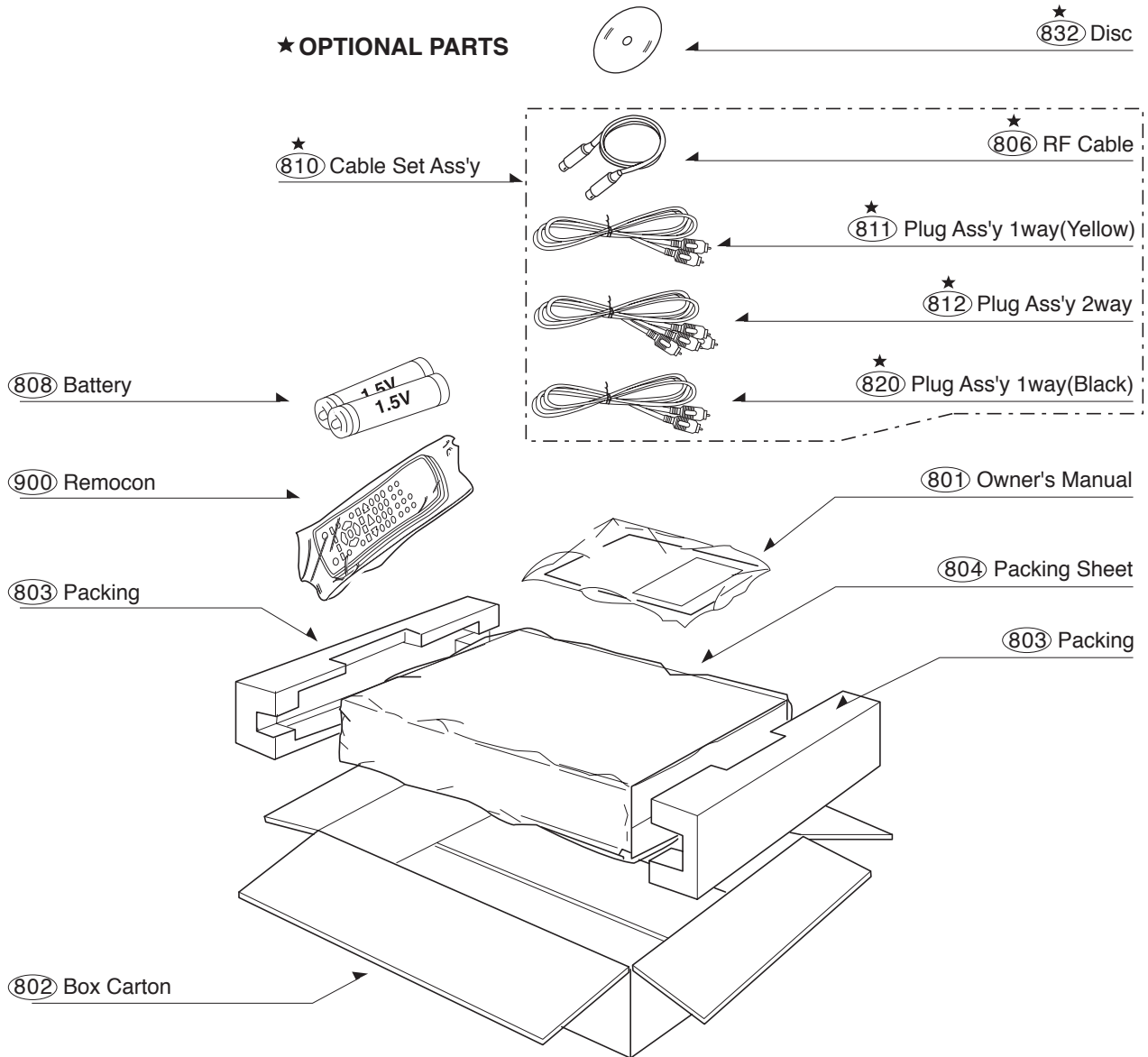

SECTION 3

ELECTRICAL

CONTENTS

ELECTRICAL TROUBLESHOOTING GUIDE	3-2
1. SMPS TROUBLESHOOTING FLOW	3-2
2. POWER CHECK FLOW	3-4
3. SYSTEM OPERATION FLOW	3-5
4. SYSTEM TEST FLOW	3-6
DETAILS AND WAVEFORMS ON SYSTEM TEST AND DEBUGGING	3-12
1. SYSTEM 27MHZ CLOCK, RESET, FLASH R/W SIGNAL	3-12
2. SDRAM CLOCK	3-14
3. TRAY OPEN/CLOSE SIGNAL	3-14
4. SLED CONTROL RELATED SIGNAL (NO DISC CONDITION)	3-15
5. LENS CONTROL RELATED SIGNAL (NO DISC CONDITION)	3-15
6. LASER POWER CONTROL RELATED SIGNAL (NO DISC CONDITION)	3-16
7. SPINDLE CONTROL WAVEFORM (NO DISC CONDITION)	3-16
8. FOCUS ON WAVEFORM	3-17
9. TRACKING CONTROL RELATED SIGNAL (SYSTEM CHECKING)	3-18
10. MT1389L AUDIO COAXIAL OUTPUT (SPDIF)	3-19
11. MT1389L VIDEO OUTPUT WAVEFORM	3-19
12. AUDIO OUTPUT FROM MT1389L	3-20
CONNECTOR PICTURE	3-21
1. ALL CONNECTOR PICTURE	3-21
2. CN201 CONNECTOR PICTURE	3-22
3. CN202 CONNECTOR PICTURE	3-22
4. CN601 CONNECTOR PICTURE	3-23
5. CN602 CONNECTOR PICTURE	3-23
6. CN605 CONNECTOR PICTURE	3-24
7. CN701 CONNECTOR PICTURE	3-24
BLOCK DIAGRAMS	3-25
1. OVERALL BLOCK DIAGRAM	3-25
2. POWER (SMPS) BLOCK DIAGRAM	3-26
3. SYSTEM BLOCK DIAGRAM	3-27
4. SERVO BLOCK DIAGRAM	3-28
5. VIDEO BLOCK DIAGRAM	3-29
6. AUDIO BLOCK DIAGRAM	3-30
CIRCUIT DIAGRAMS	3-31
1. POWER (SMPS) CIRCUIT DIAGRAM	3-31
2. SYSTEM (MPEG) CIRCUIT DIAGRAM	3-33
3. SERVO CIRCUIT DIAGRAM	3-35
4. AV (JACK) CIRCUIT DIAGRAM	3-37
5. 5.1CH CIRCUIT DIAGRAM (OPTION)	3-39
6. KARAOKE & USB CIRCUIT DIAGRAM (OPTION)	3-41
7. KEY CIRCUIT DIAGRAM	3-43
8. TIMER CIRCUIT DIAGRAM	3-45
• CIRCUIT VOLTAGE CHART	3-53
PRINTED CIRCUIT BOARD DIAGRAMS	3-55
1. MAIN P.C.BOARD	3-55
2. POWER (SMPS) P.C.BOARD	3-57
3. 5.1CH & SCART P.C.BOARD (OPTIONAL PART)	3-57
4. KARAOKE & USB P.C.BOARD (OPTIONAL PART)	3-59
5. KEY P.C.BOARD	3-63
6. TIMER P.C.BOARD	3-63

ELECTRICAL TROUBLESHOOTING GUIDE

1. SMPS TROUBLESHOOTING FLOW

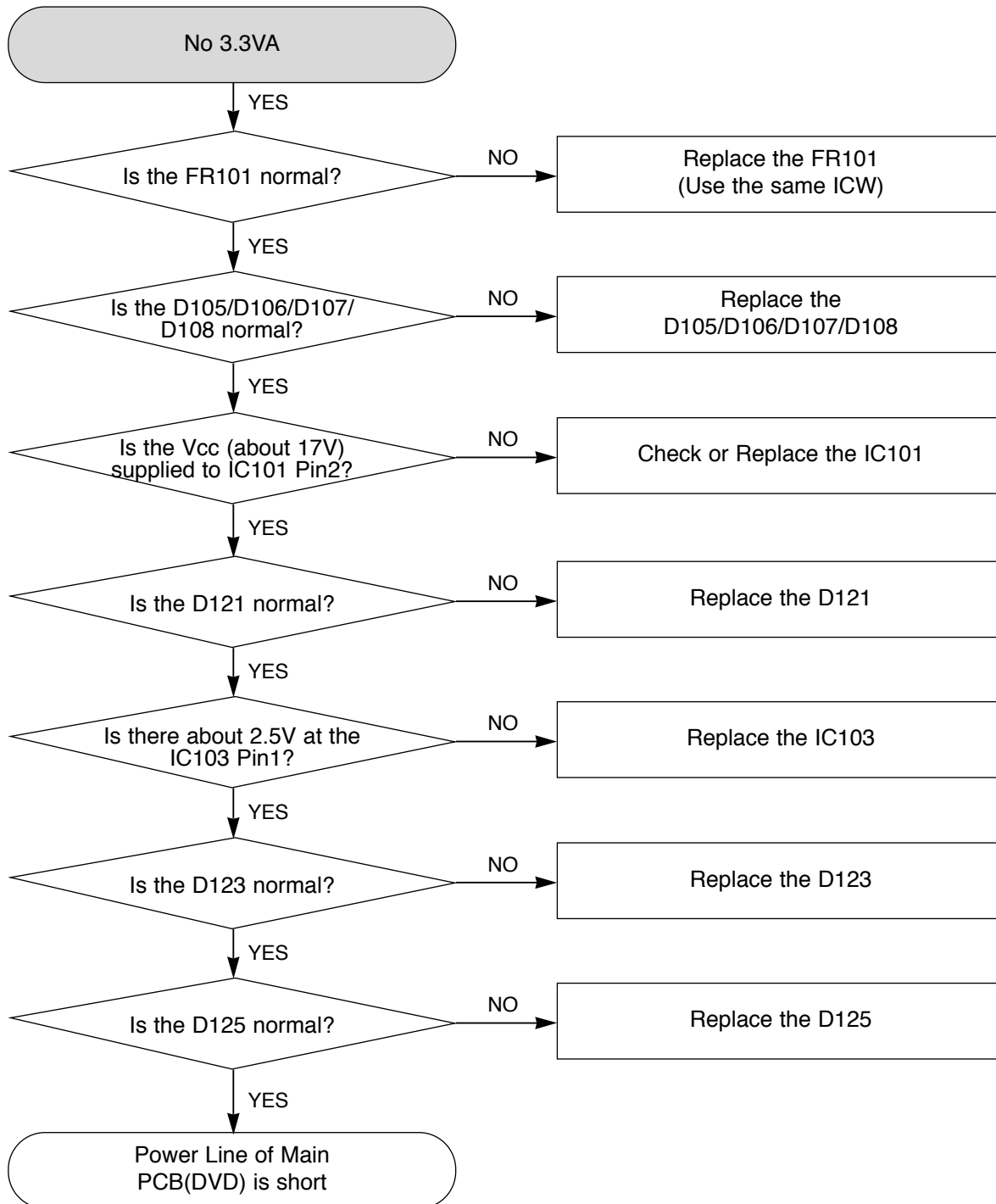

ELECTRICAL TROUBLESHOOTING GUIDE

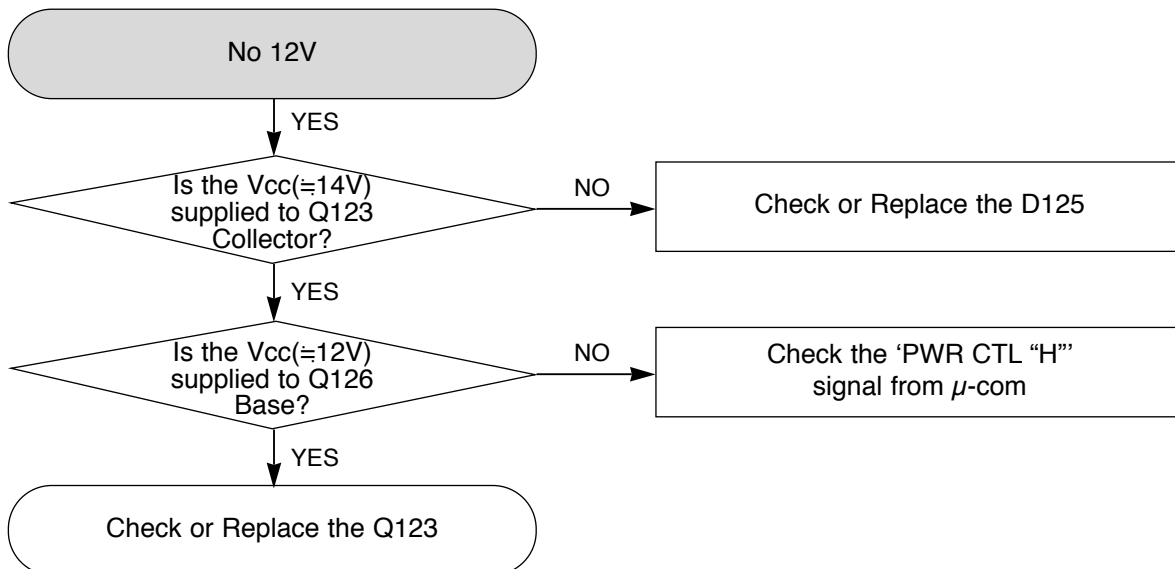
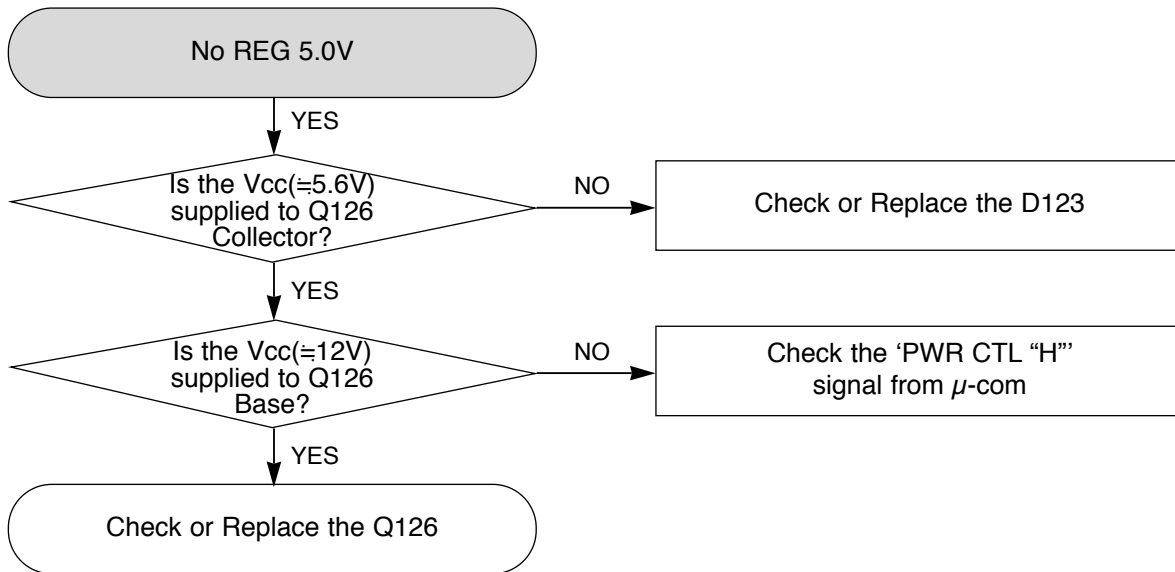

ELECTRICAL TROUBLESHOOTING GUIDE

2. POWER CHECK FLOW

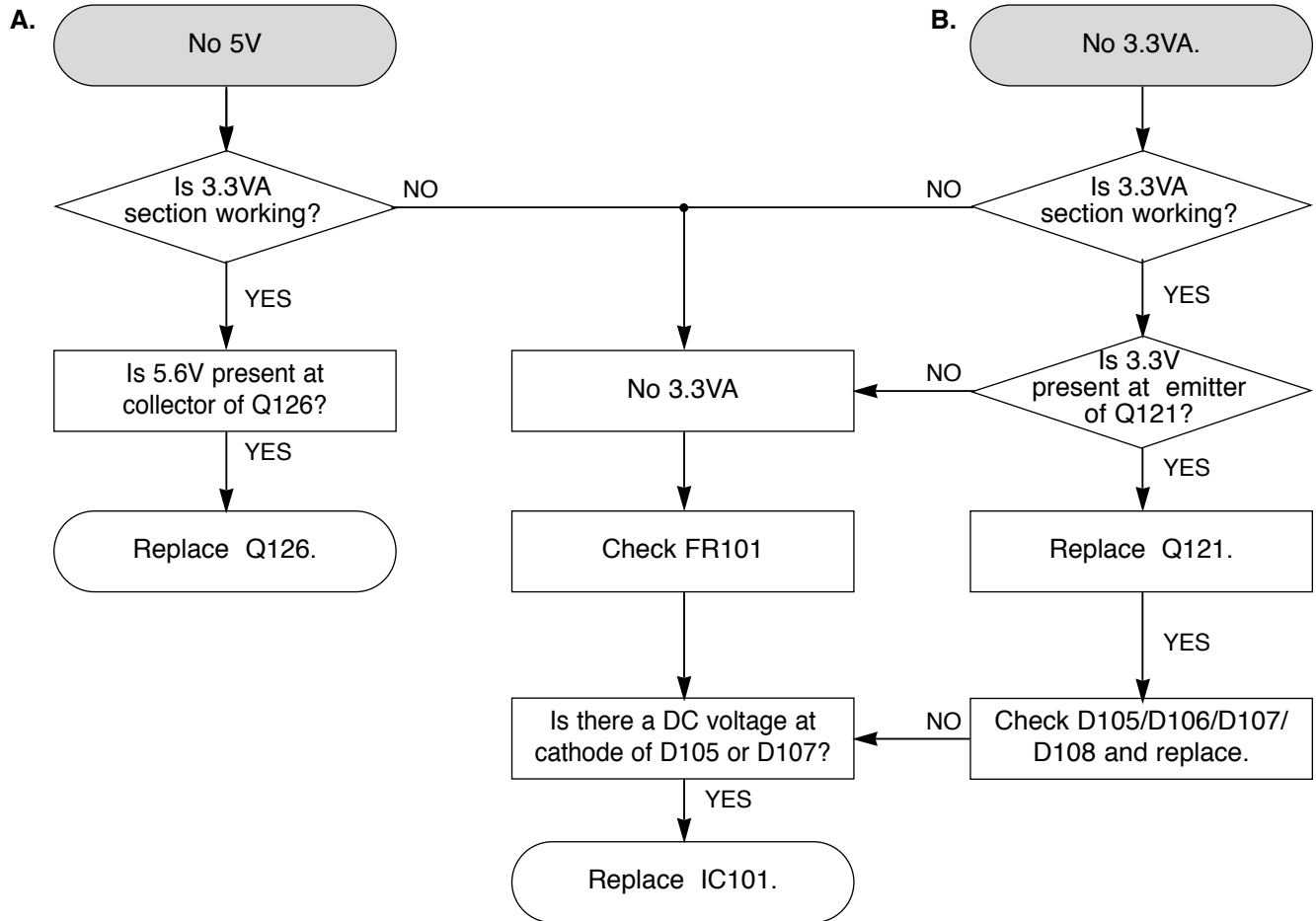

ELECTRICAL TROUBLESHOOTING GUIDE

3. SYSTEM OPERATION FLOW

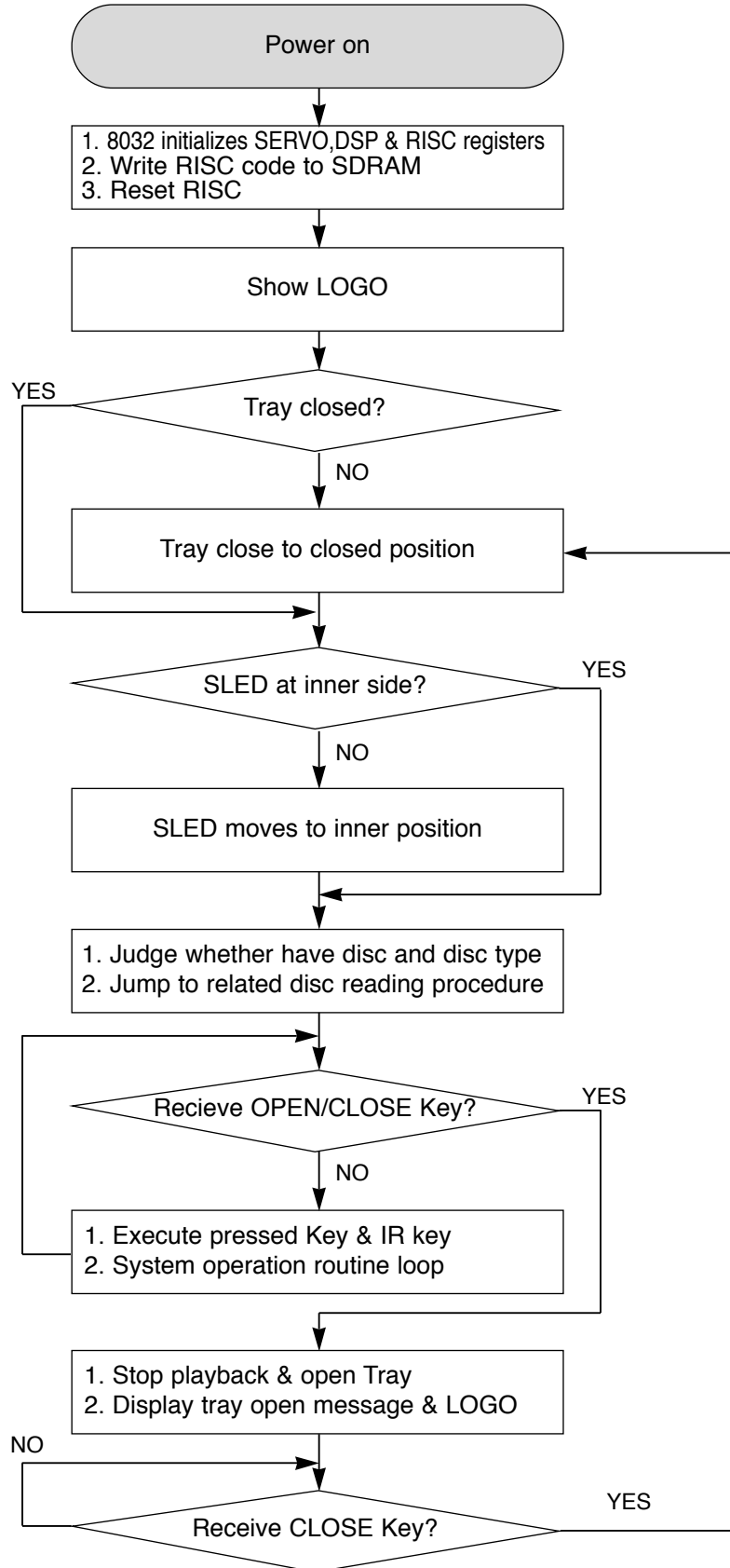

ELECTRICAL TROUBLESHOOTING GUIDE

4. SYSTEM TEST FLOW

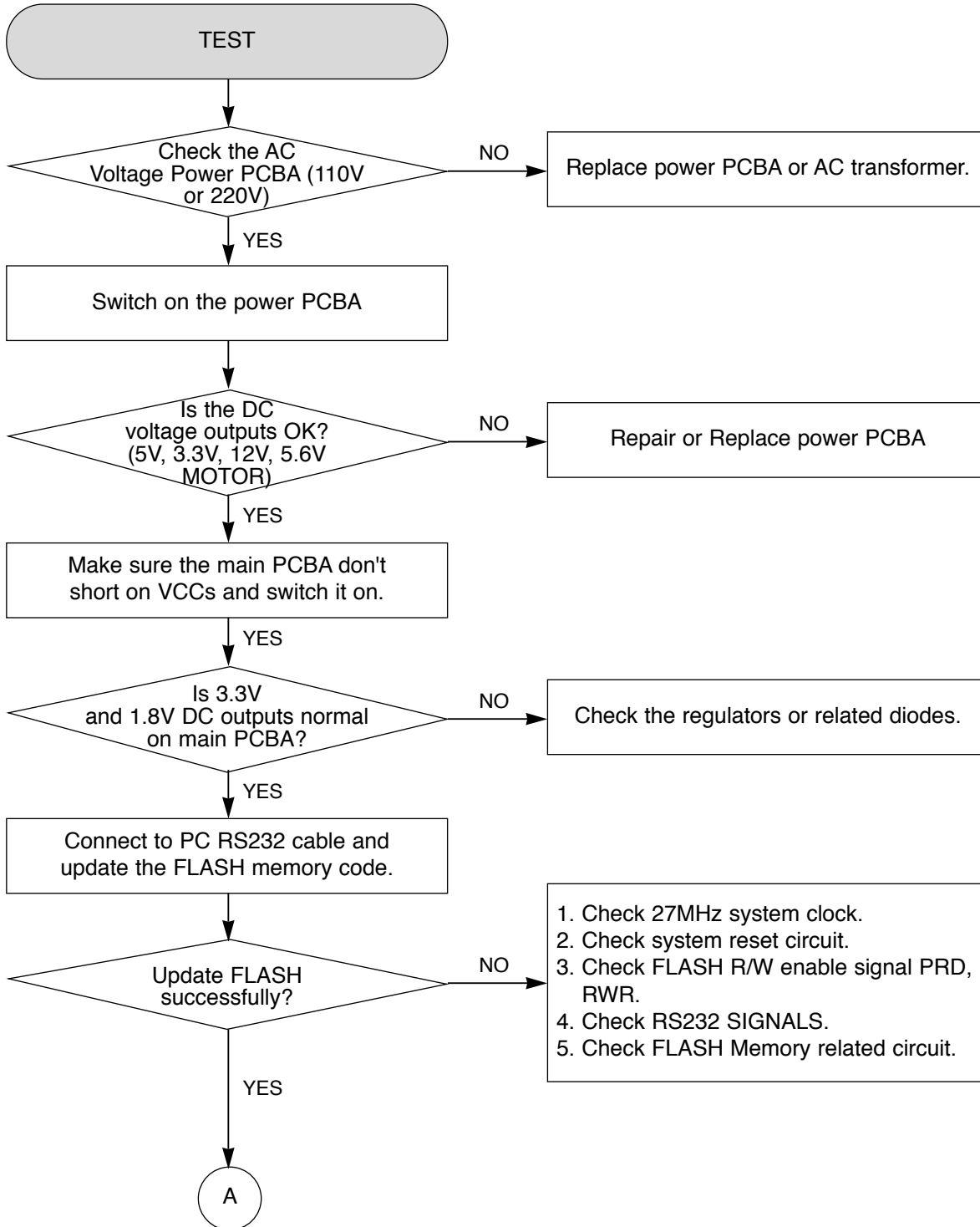

ELECTRICAL TROUBLESHOOTING GUIDE

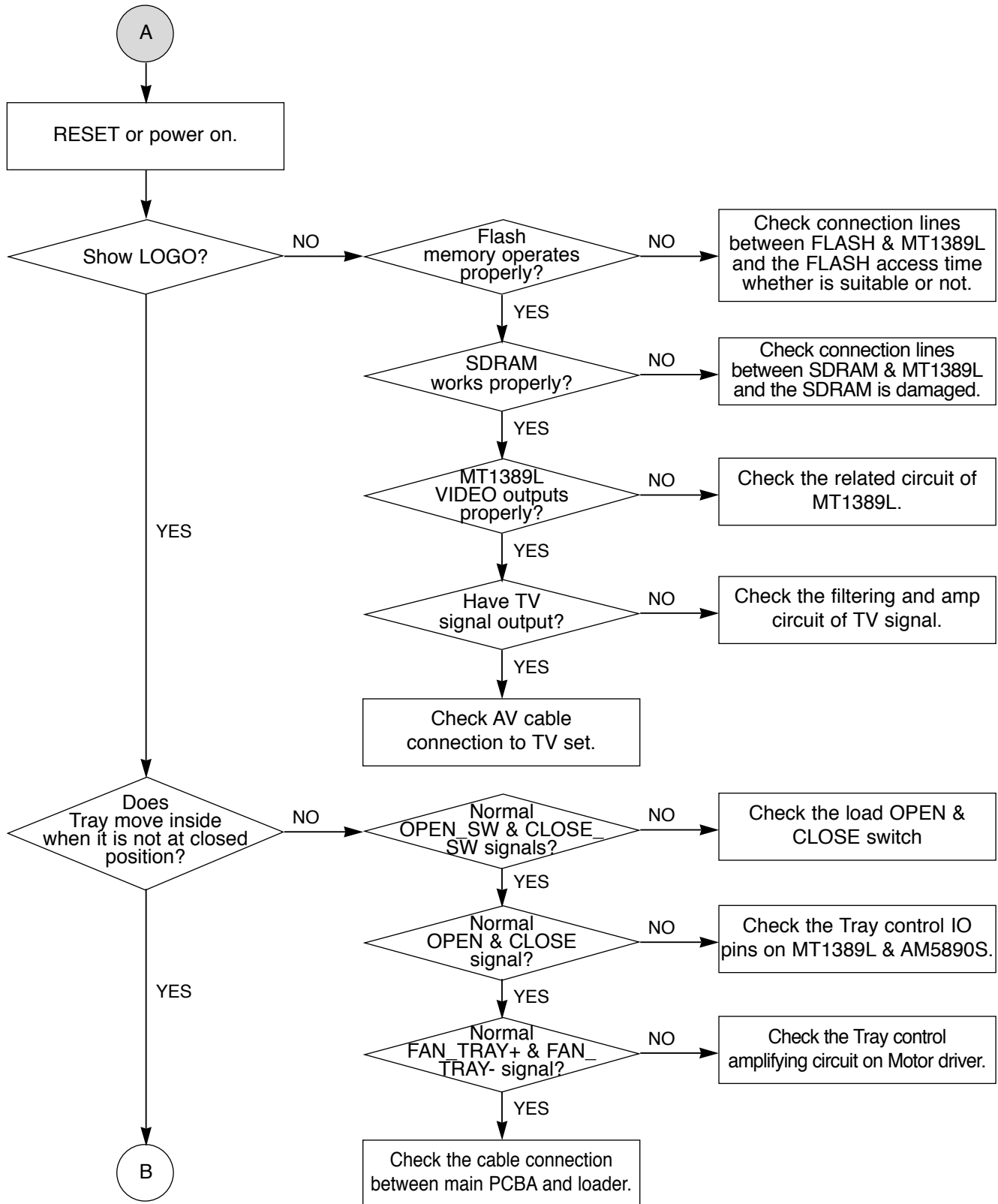

ELECTRICAL TROUBLESHOOTING GUIDE

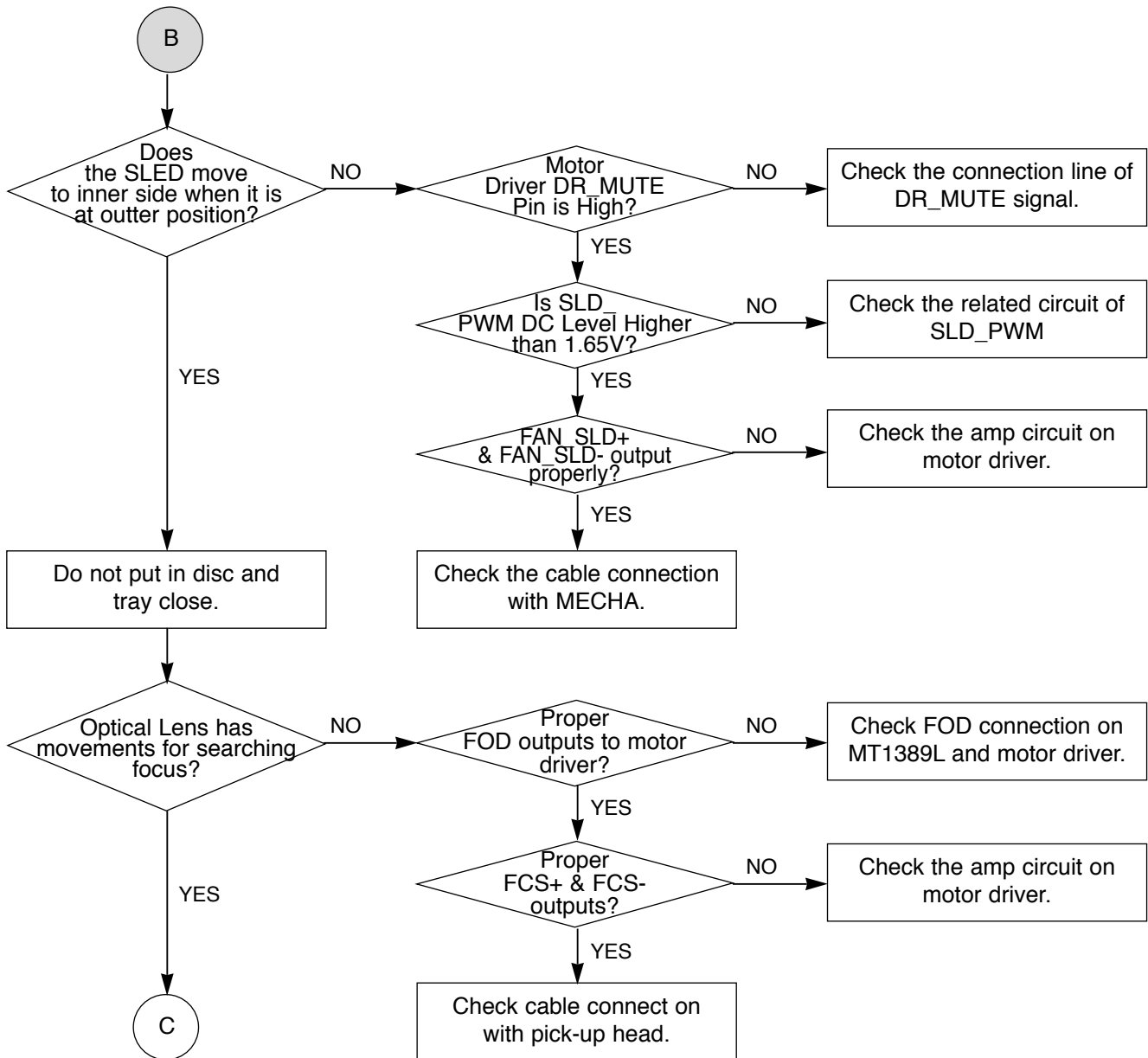

ELECTRICAL TROUBLESHOOTING GUIDE

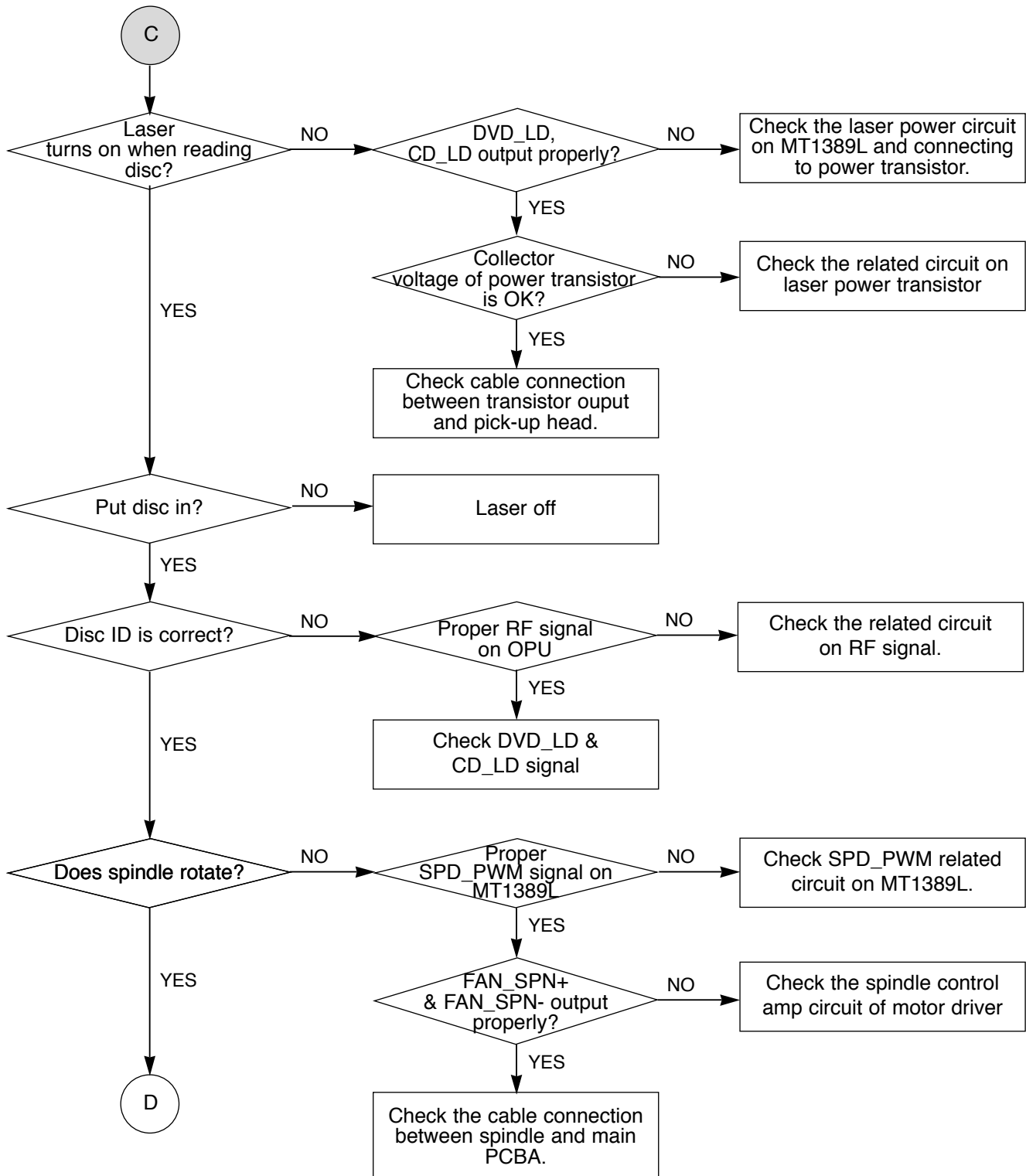

ELECTRICAL TROUBLESHOOTING GUIDE

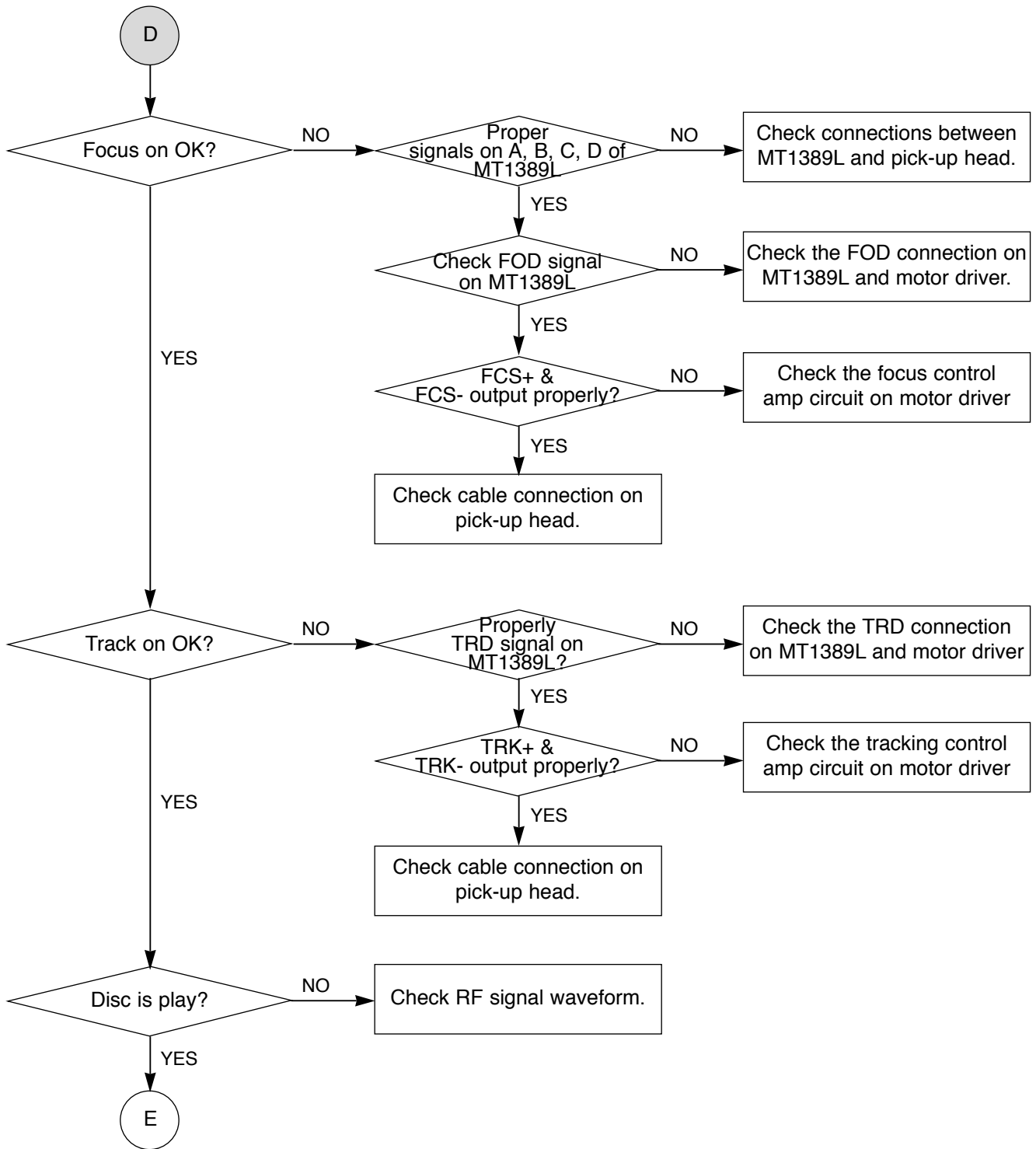

ELECTRICAL TROUBLESHOOTING GUIDE

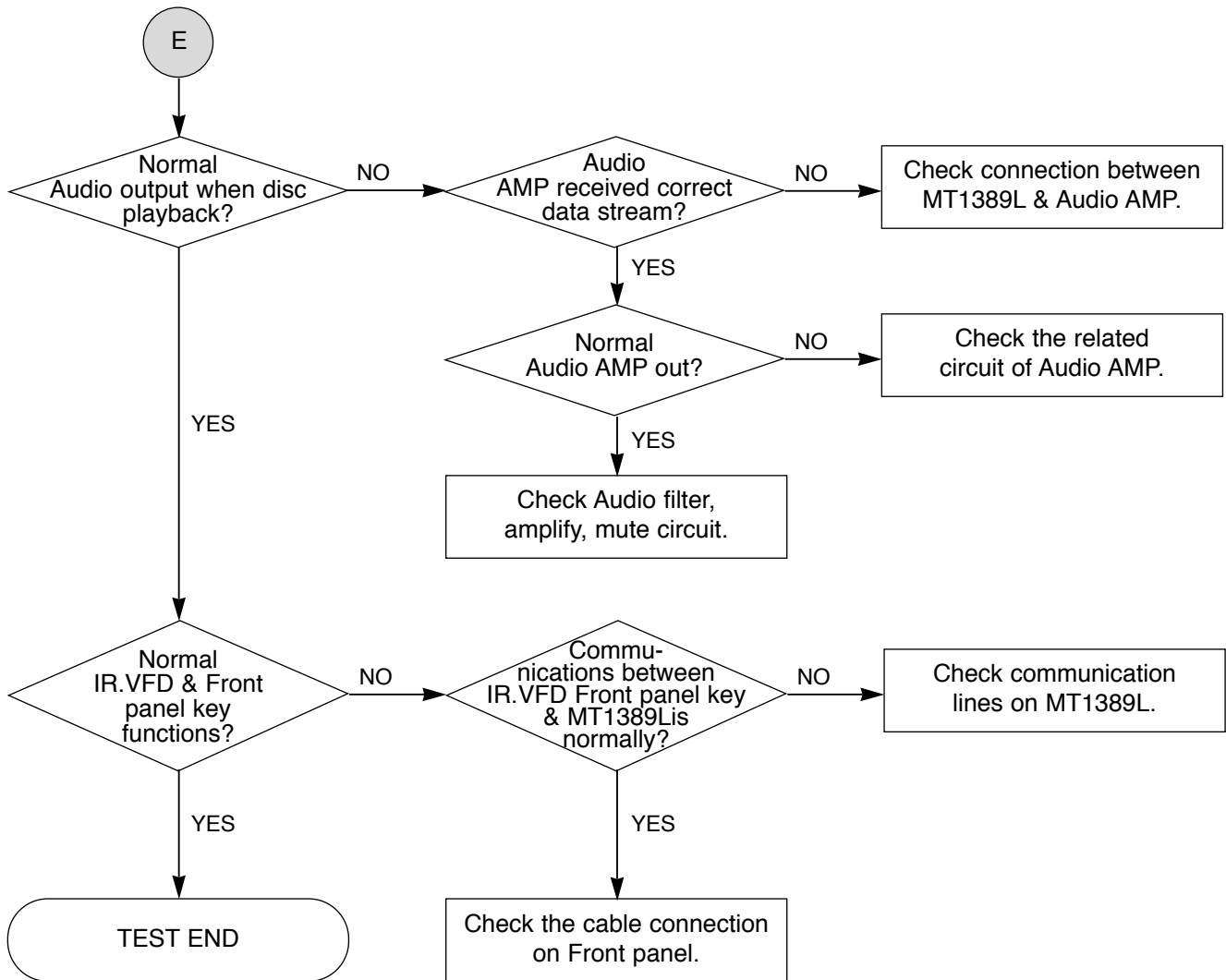

DETAILS AND WAVEFORMS ON SYSTEM TEST AND DEBUGGING

1. SYSTEM 27MHz CLOCK, RESET, FLASH R/W SIGNAL

1) MT1389L main clock is at 27MHz (X601)

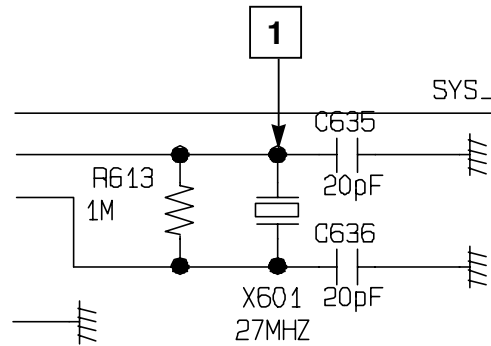
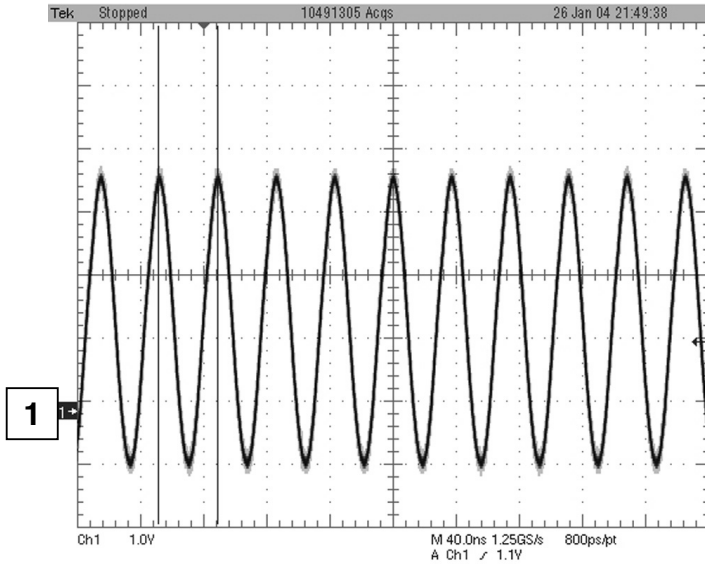

FIG 1-1

2) MT1389L reset is active high.

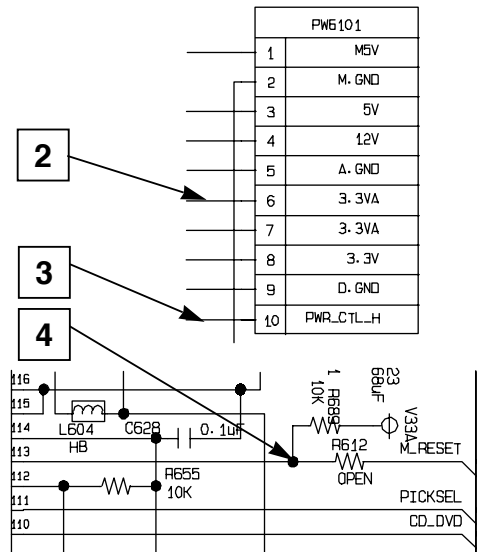
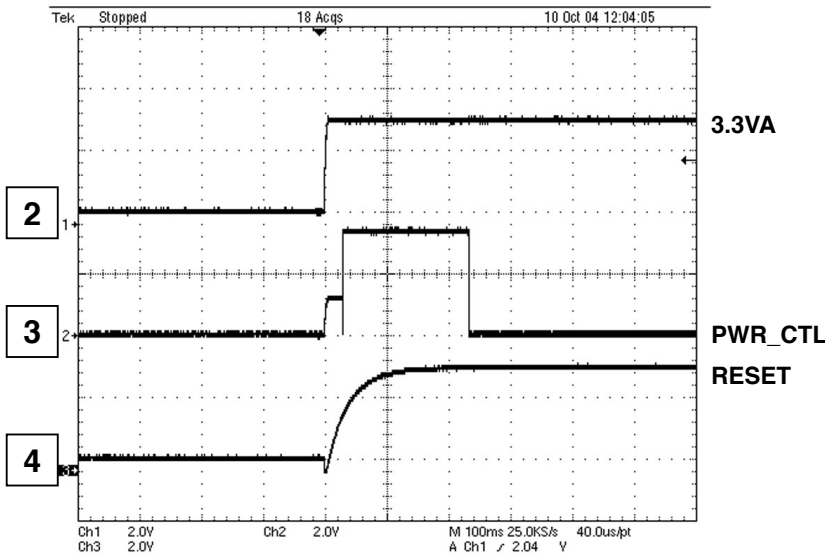

FIG 1-2

3) RS232 waveform during procedure (Downloading)

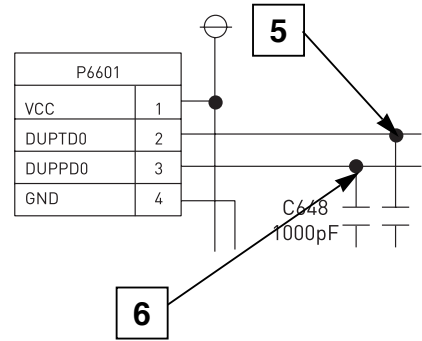
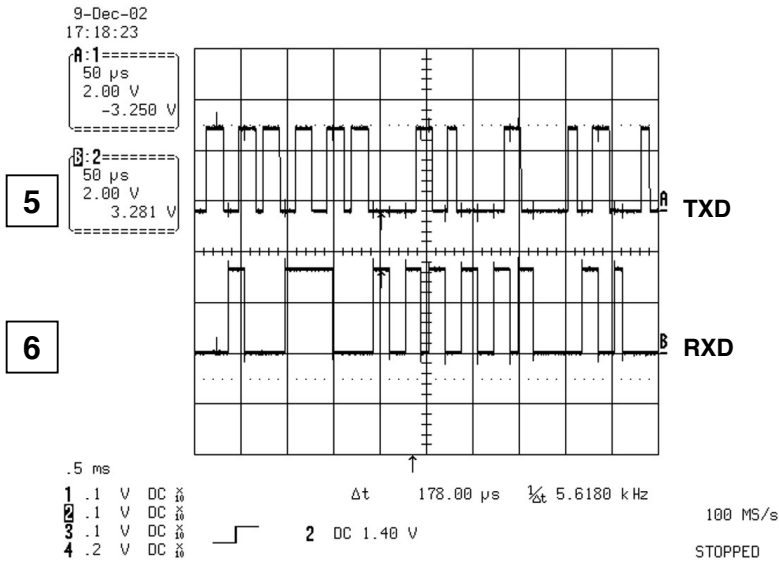

FIG 1-3

4) Flash CE# enable signal and SCK signal during Downloading

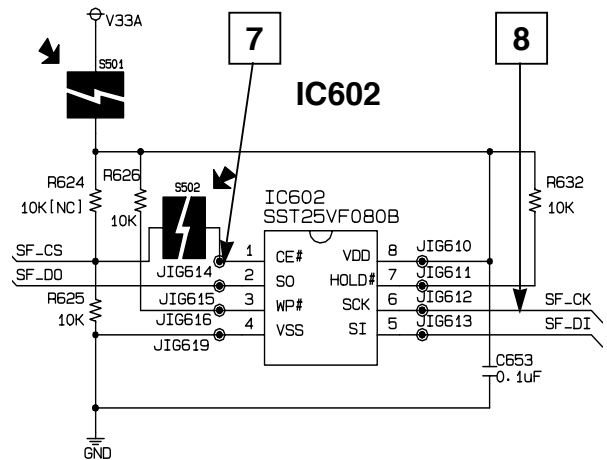
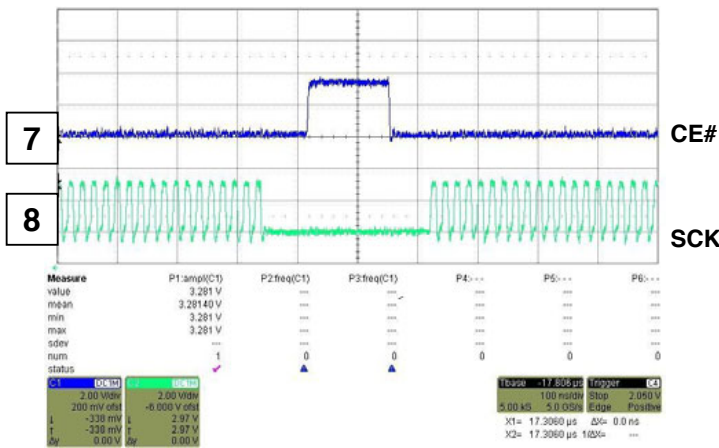

FIG 1-4

2. SDRAM CLOCK

DCLK = 128MHz, Vp-p=2.2, Vmax=2.7V

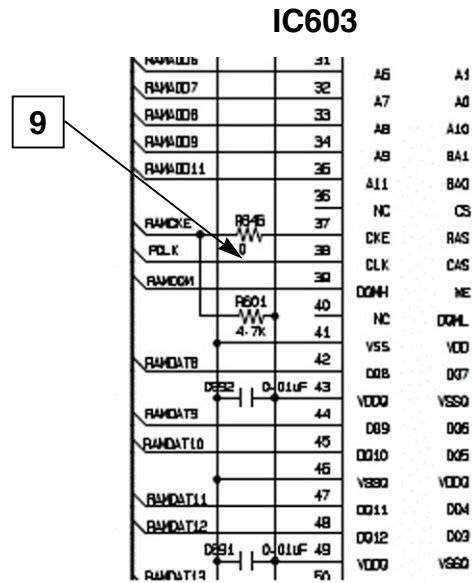
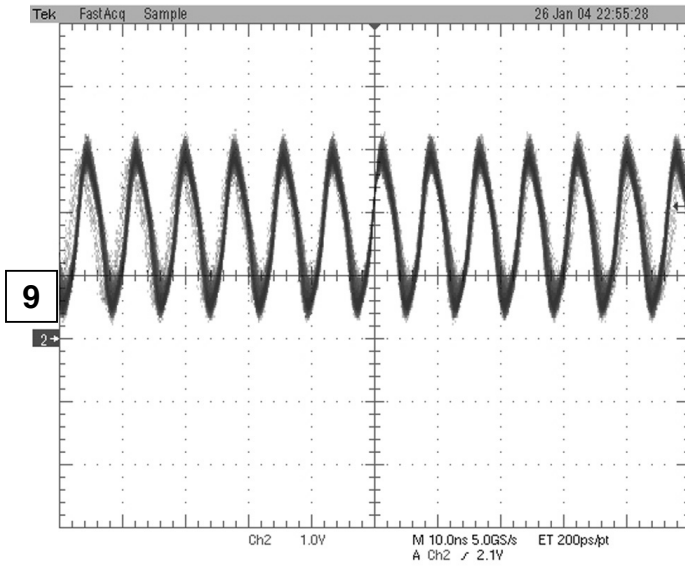

FIG 2-1

3. TRAY OPEN/CLOSE SIGNAL

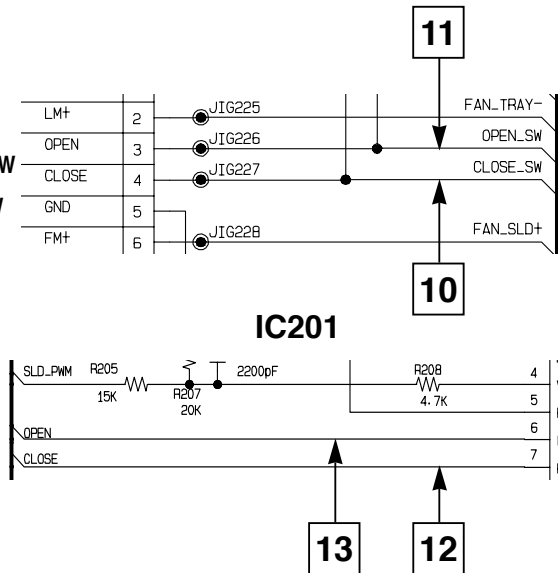
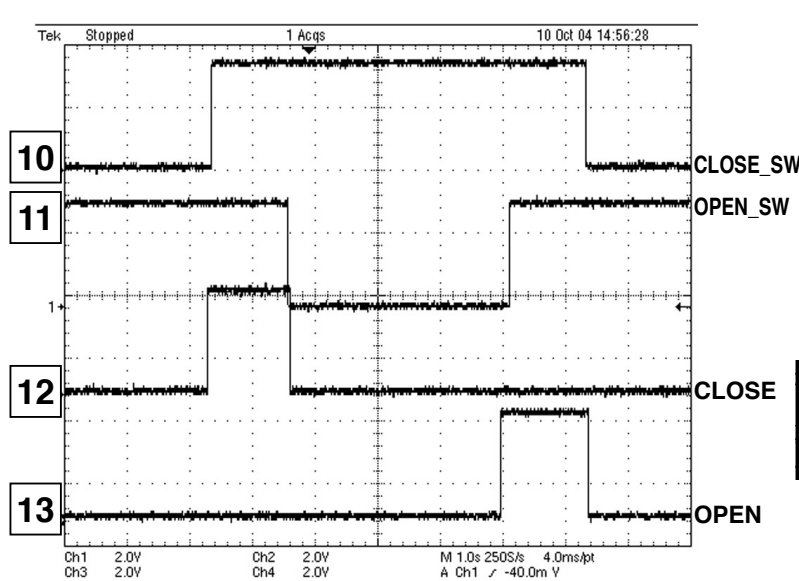

FIG 3-1

4. SLED CONTROL RELATED SIGNAL (NO DISC CONDITION)

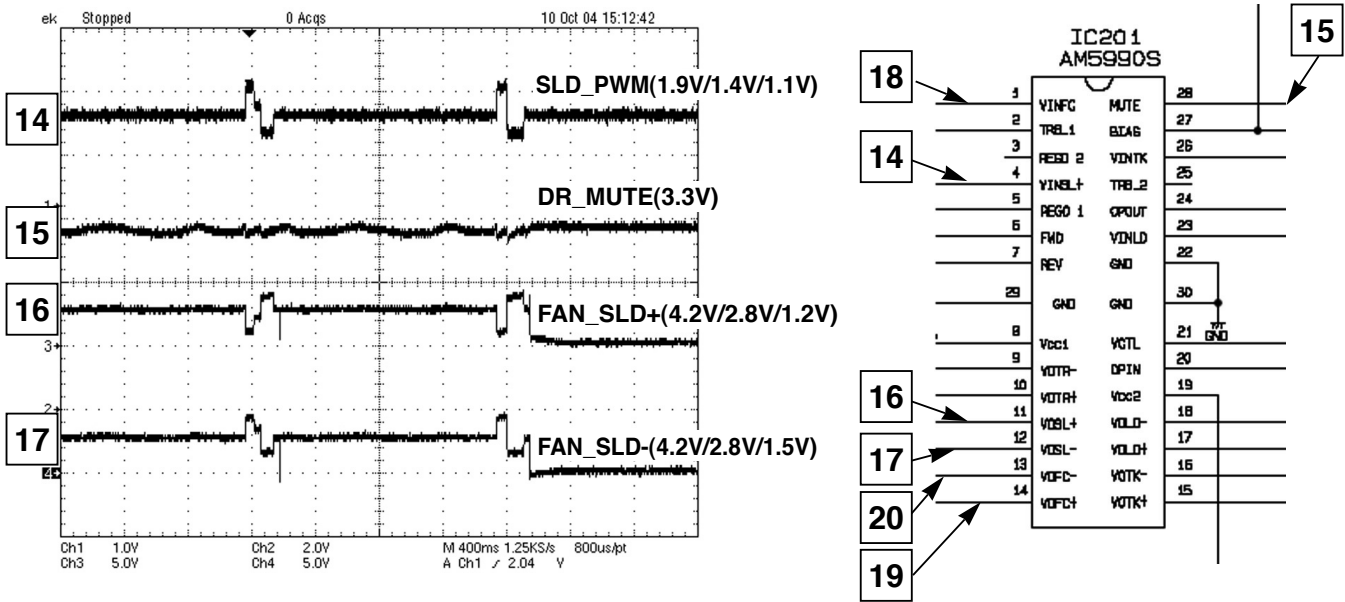

FIG 4-1

5. LENS CONTROL RELATED SIGNAL (NO DISC CONDITION)

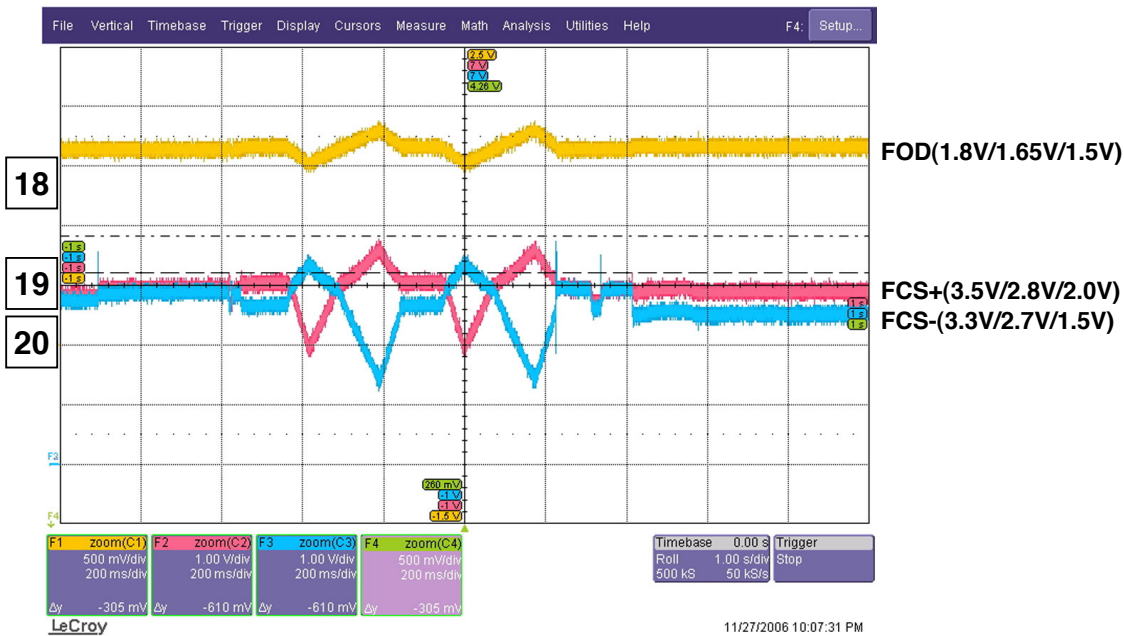

FIG 5-1

6. LASER POWER CONTROL RELATED SIGNAL (NO DISC CONDITION)

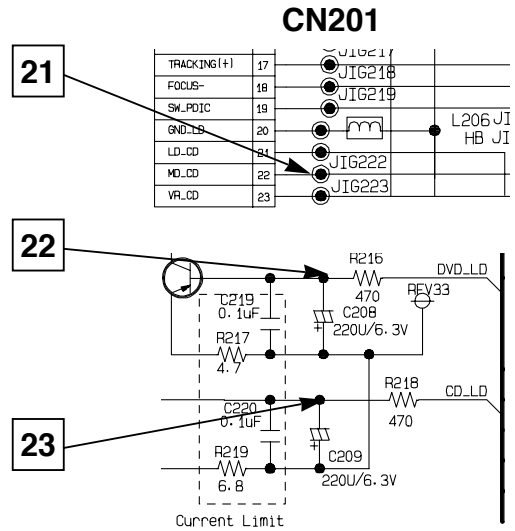
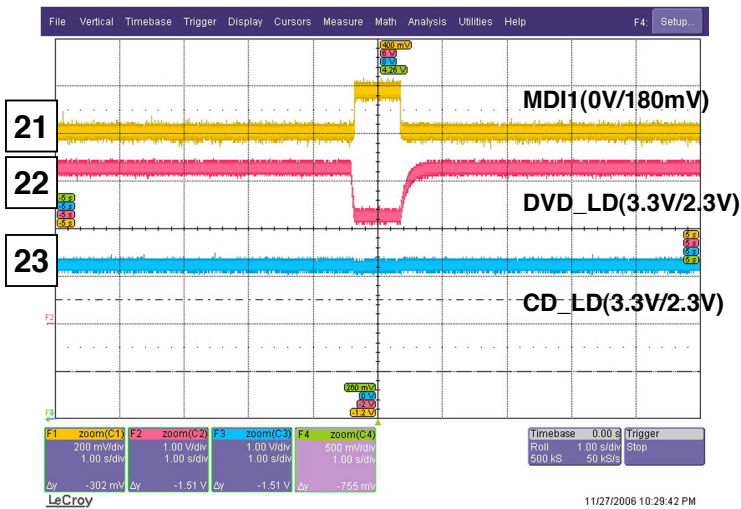

FIG 6-1

7. SPINDLE CONTROL WAVEFORM (NO DISC CONDITION)

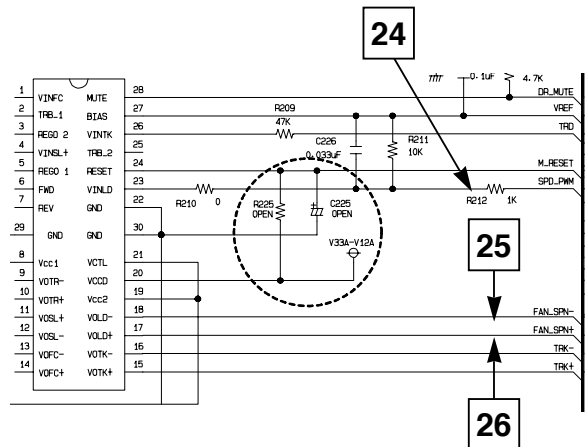
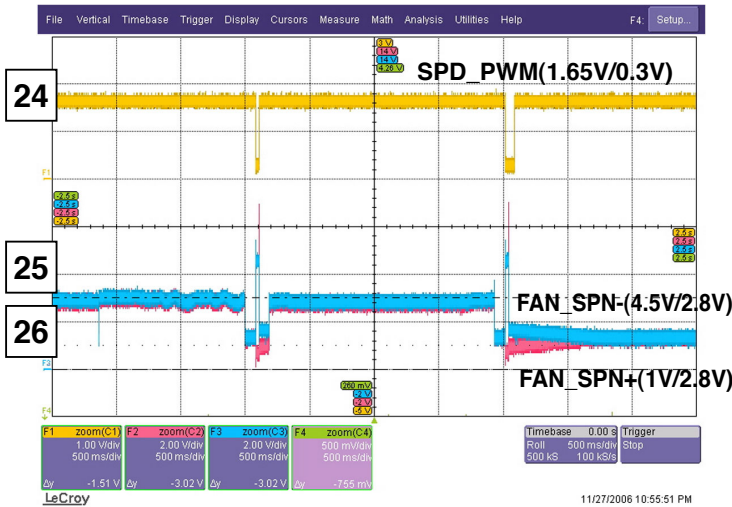

FIG 7-1

8. FOCUS ON WAVEFORM

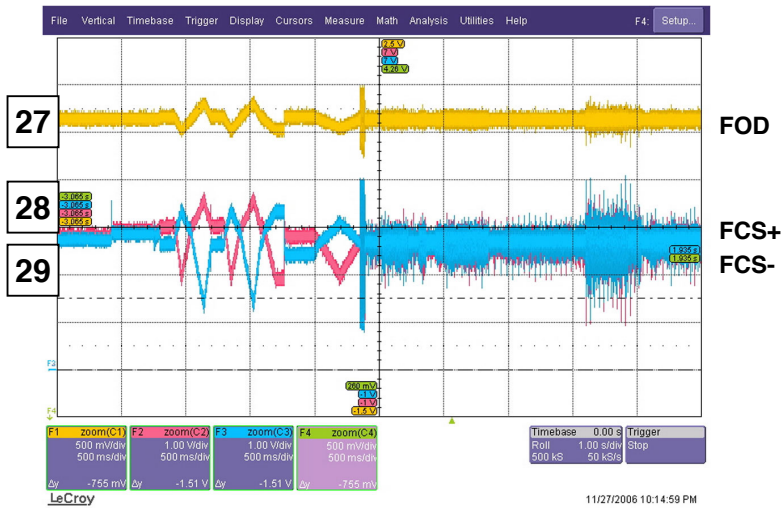

FIG 8-1 (DVD)

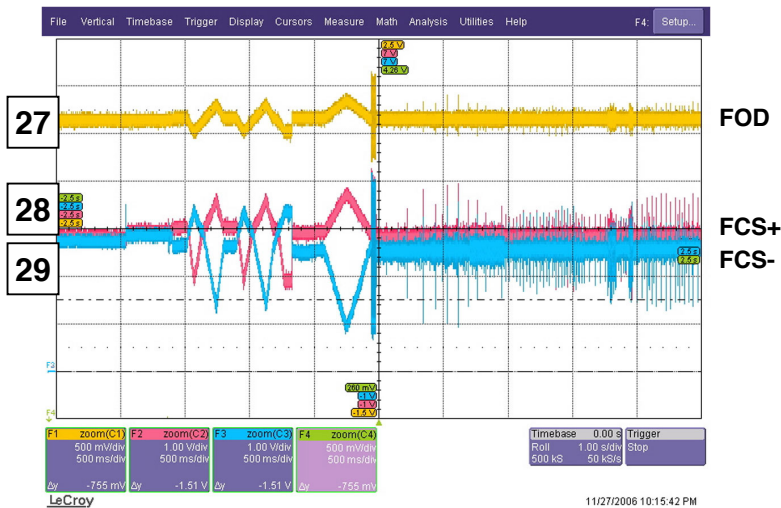
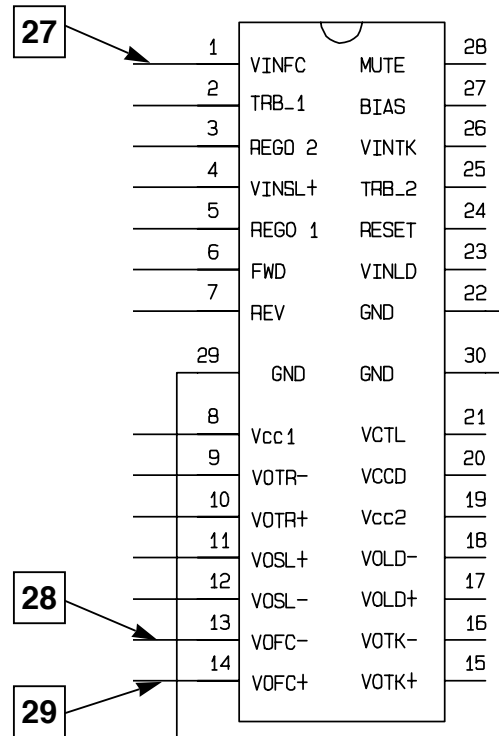

FIG 8-2 (CD)

IC201

IC201
AM5890S



9. TRACKING CONTROL RELATED SIGNAL (SYSTEM CHECKING)

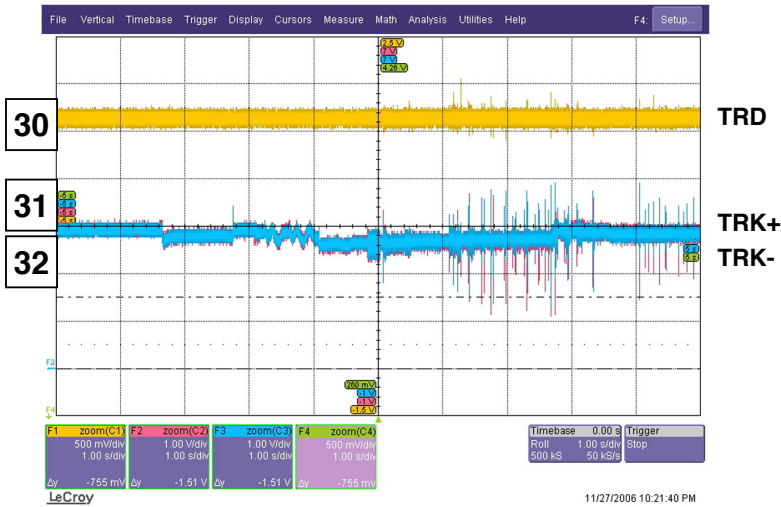

FIG 9-1 (DVD)

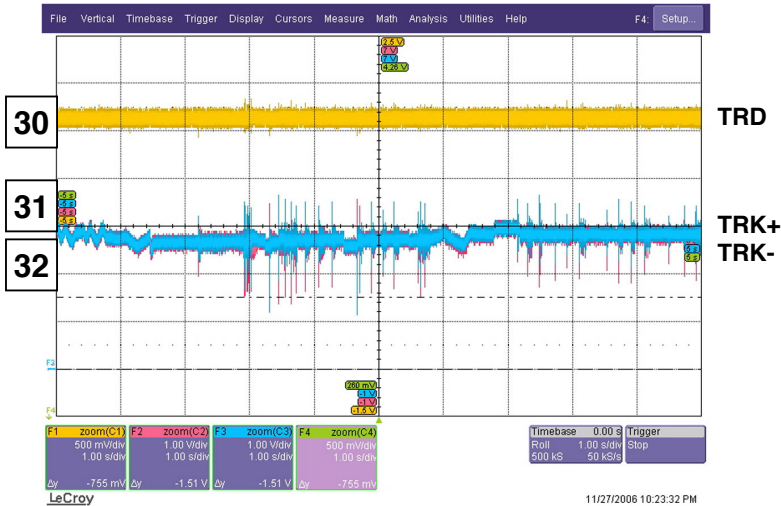
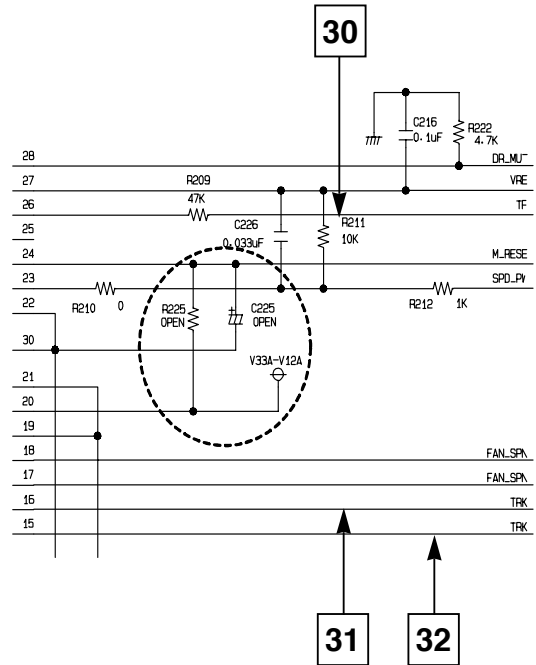

FIG 9-2 (CD)

10. MT1389L AUDIO COAXIAL OUTPUT (SPDIF)

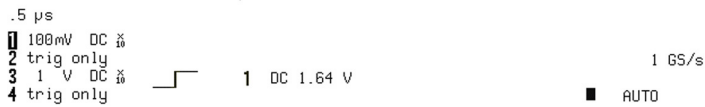
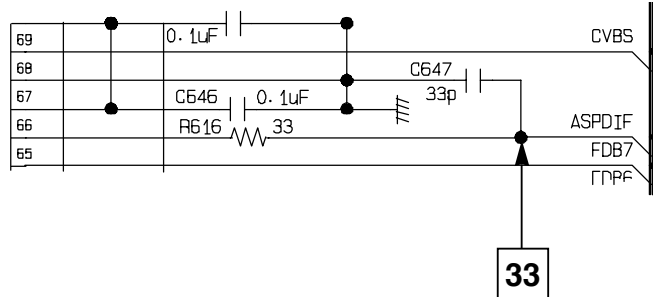
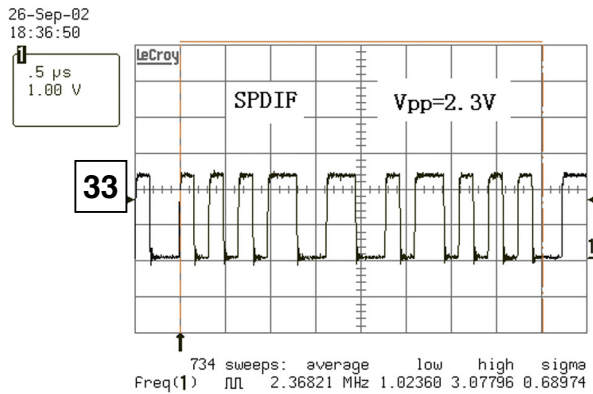

FIG 10-1

11. MT1389L VIDEO OUTPUT WAVEFORM

1) 100% COLOR BAR

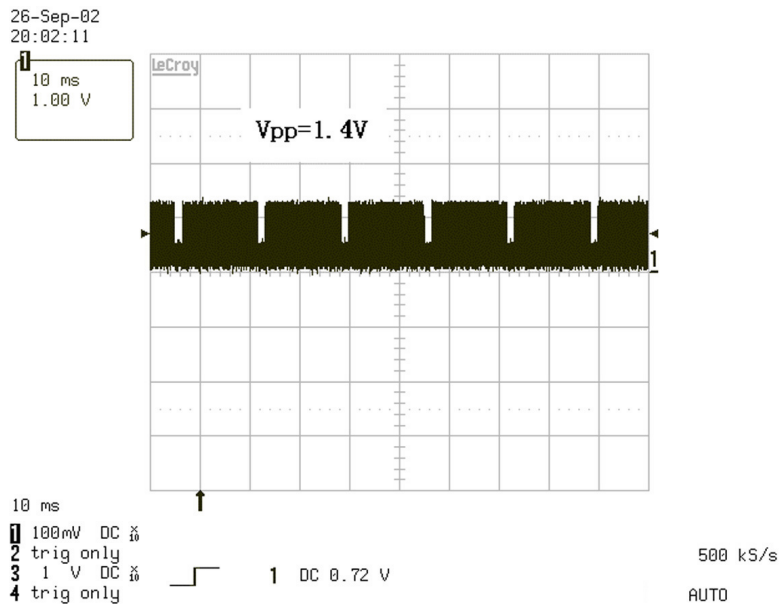

FIG 11-1

2) COMPOSITE VIDEO SIGNAL

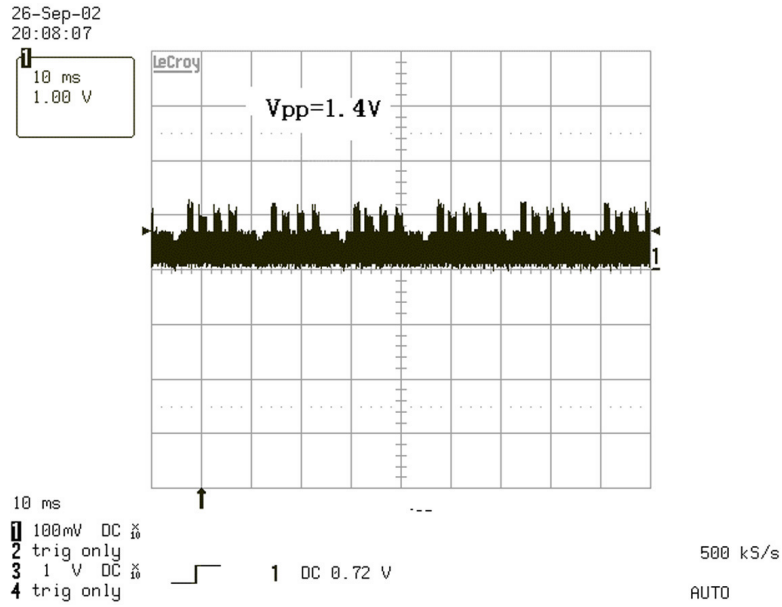

FIG 11-2

12. AUDIO OUTPUT FROM MT1389L

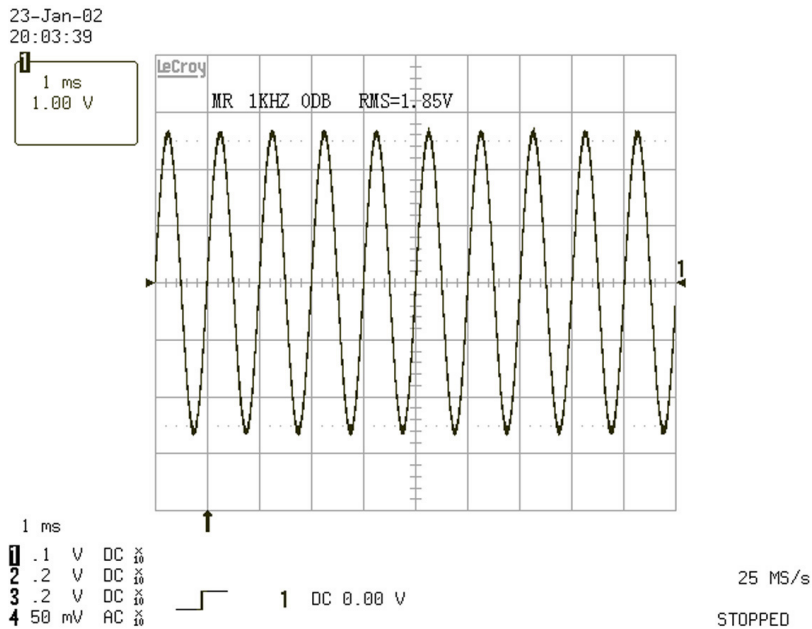
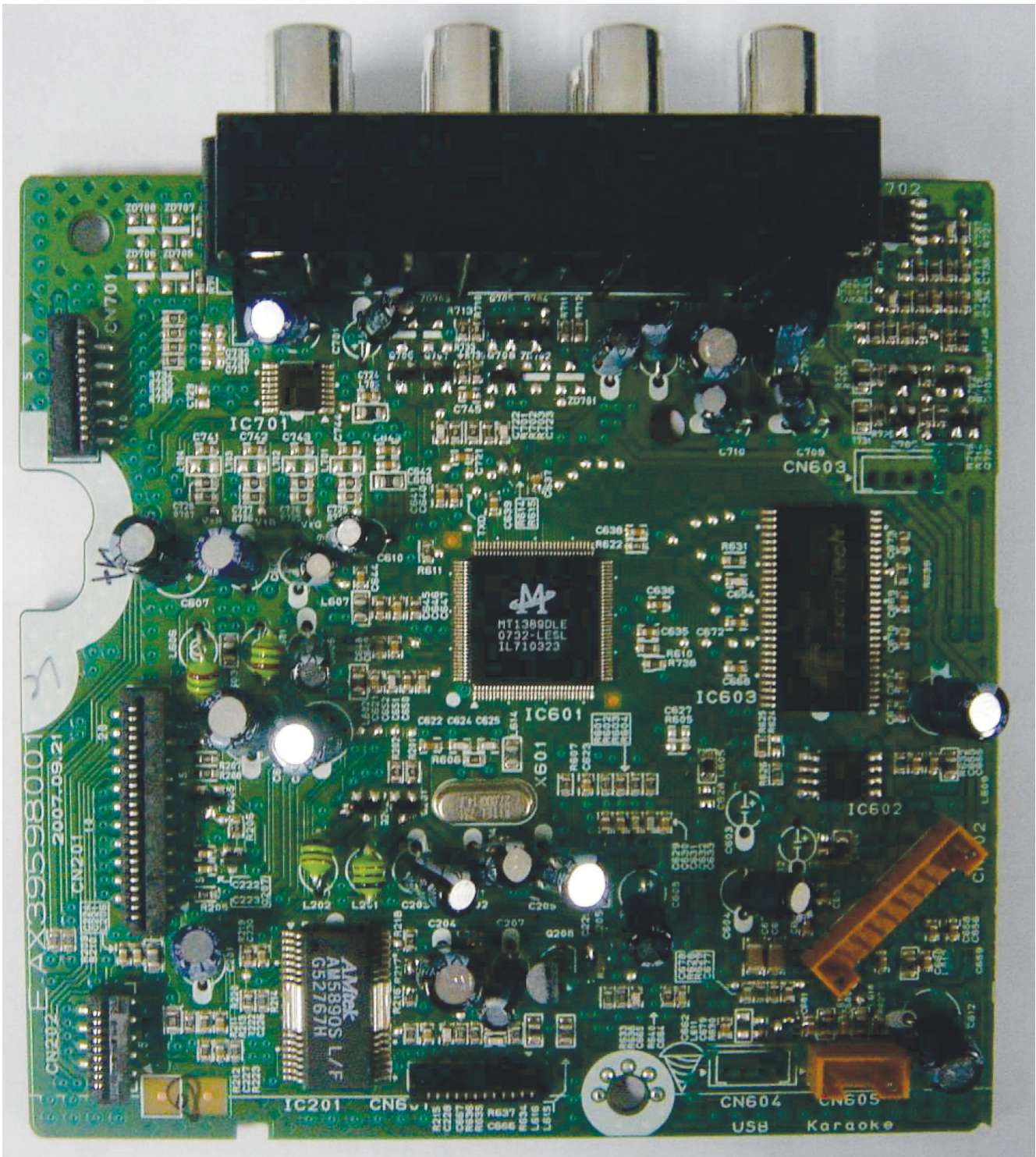

FIG 12-1

CONNECTOR PICTURE

1. ALL CONNECTOR PICTURE



2. CN201 CONNECTOR PICTURE

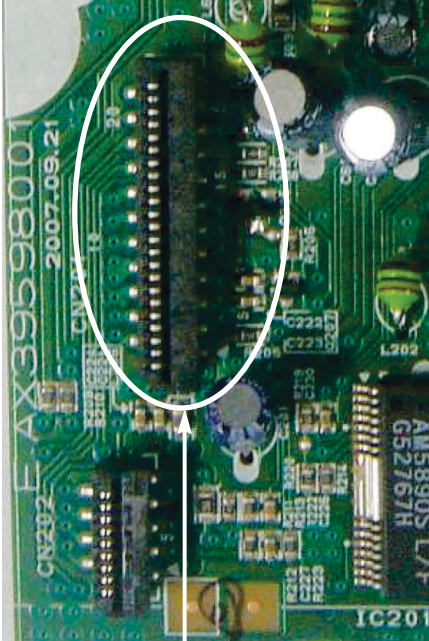

FROM PICKUP

CN20 1			
NC/FHM-VCC	1	D	12
RF	2	C	13
DVD-LD	3	B	14
MON(COM)/5V	4	F(+)	15
DVD_VR	5	T(+)	16
GND	6	T(-)	17
VREF/VC	7	F(-)	18
VCC	8	SW_PDIC	19
F	9	GND	20
E	10	CD_LD	21
A	11	MON/MPD	22
		CD_VR	23

CN201 (MD 23PIN)

3. CN202 CONNECTOR PICTURE

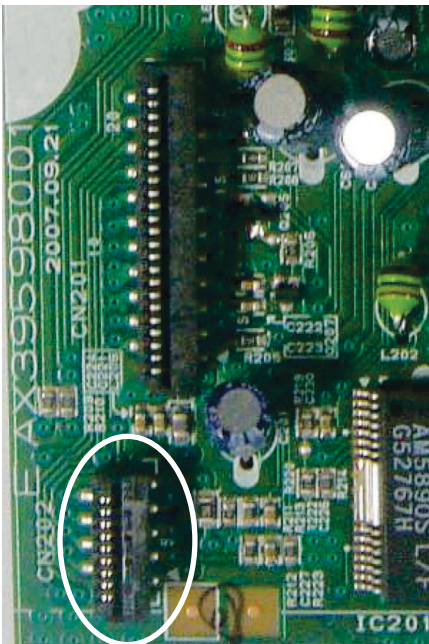

CN202	
LM-	1
LM+	2
OPEN	3
CLOSE	4
GND	5
FM+	6
FM-	7
SP+	8
SP-	9

CN202 (MD 9PIN)

4. CN601 CONNECTOR PICTURE

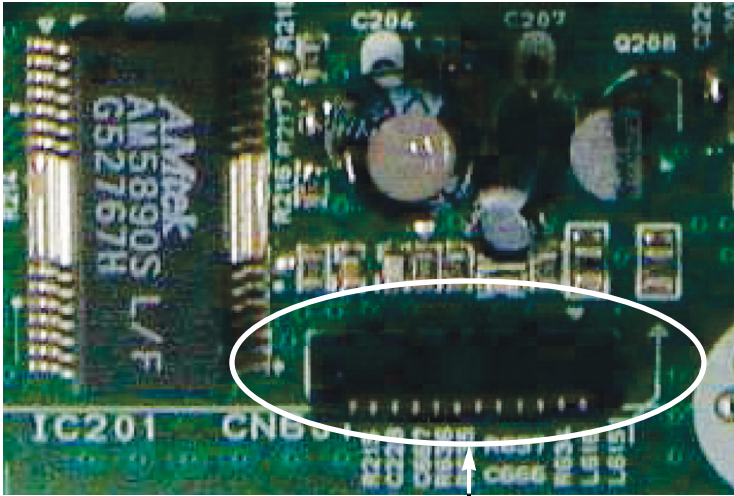

TO FRONT PCB

12	DOUT
11	DIN
10	GND
9	CLK
8	STB
7	GND
6	IR
5	GND
4	3.3VA
3	5V
2	GND
1	POWER_KEY
CN601	

CN601 (FP 12PIN)

5. CN602 CONNECTOR PICTURE

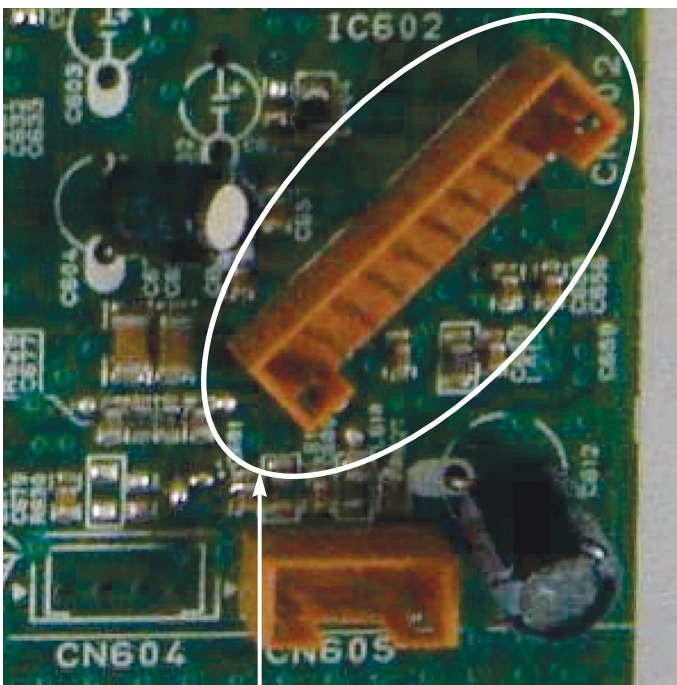

FROM POWER PCB

CN602	
1	5VA
2	M. GND
3	5V
4	12V
5	A. GND
6	3.3VA
7	3.3VA
8	3.3V
9	D. GND
10	PWR_CTL_H

CN602 (POWER 10PIN)

6. CN605 CONNECTOR PICTURE

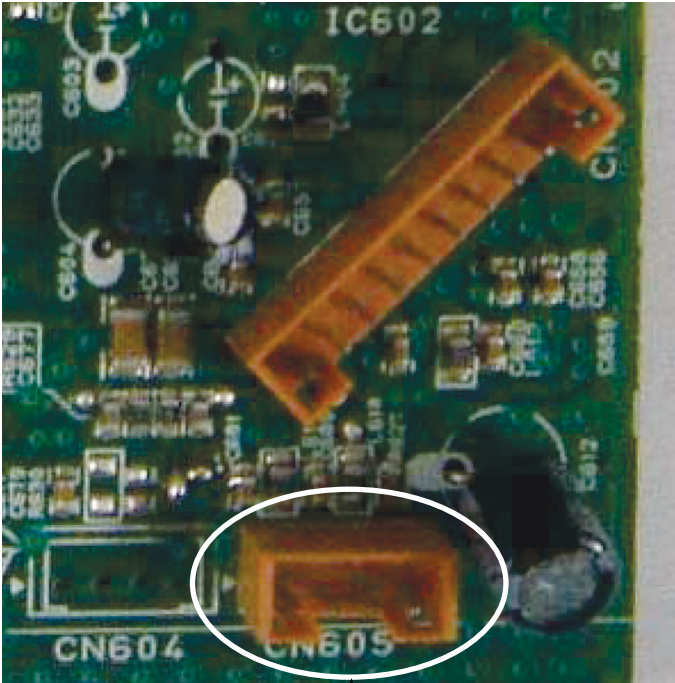

CN605	
1	12V
2	GND
3	MIC_DET
4	MIC_IN

CN605 (KARAOKE 4PIN)

7. CN701 CONNECTOR PICTURE

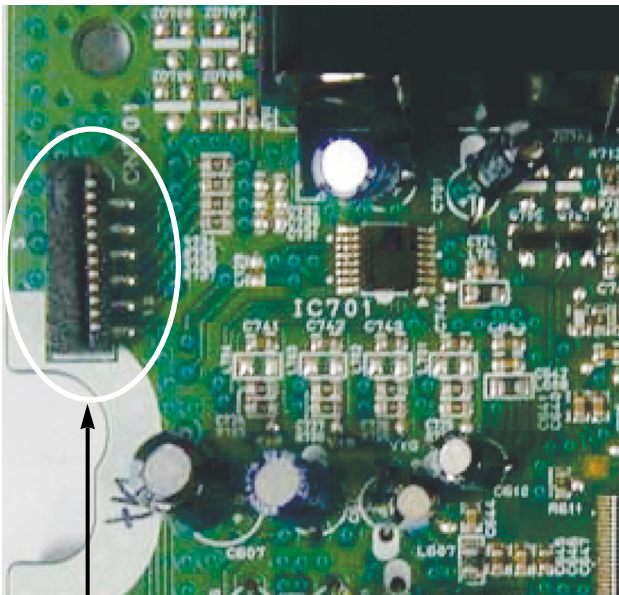

CN701	
1	12V
2	16_9_H
3	GND
4	CVBS_OUT
5	RGB_H
6	R_OUT
7	G_OUT
8	B_OUT
9	GND
10	DVD_AUDIO_L
11	DVD_AUDIO_R
12	GND

CN701 (SCART 12PIN)

BLOCK DIAGRAMS

1. OVERALL BLOCK DIAGRAM

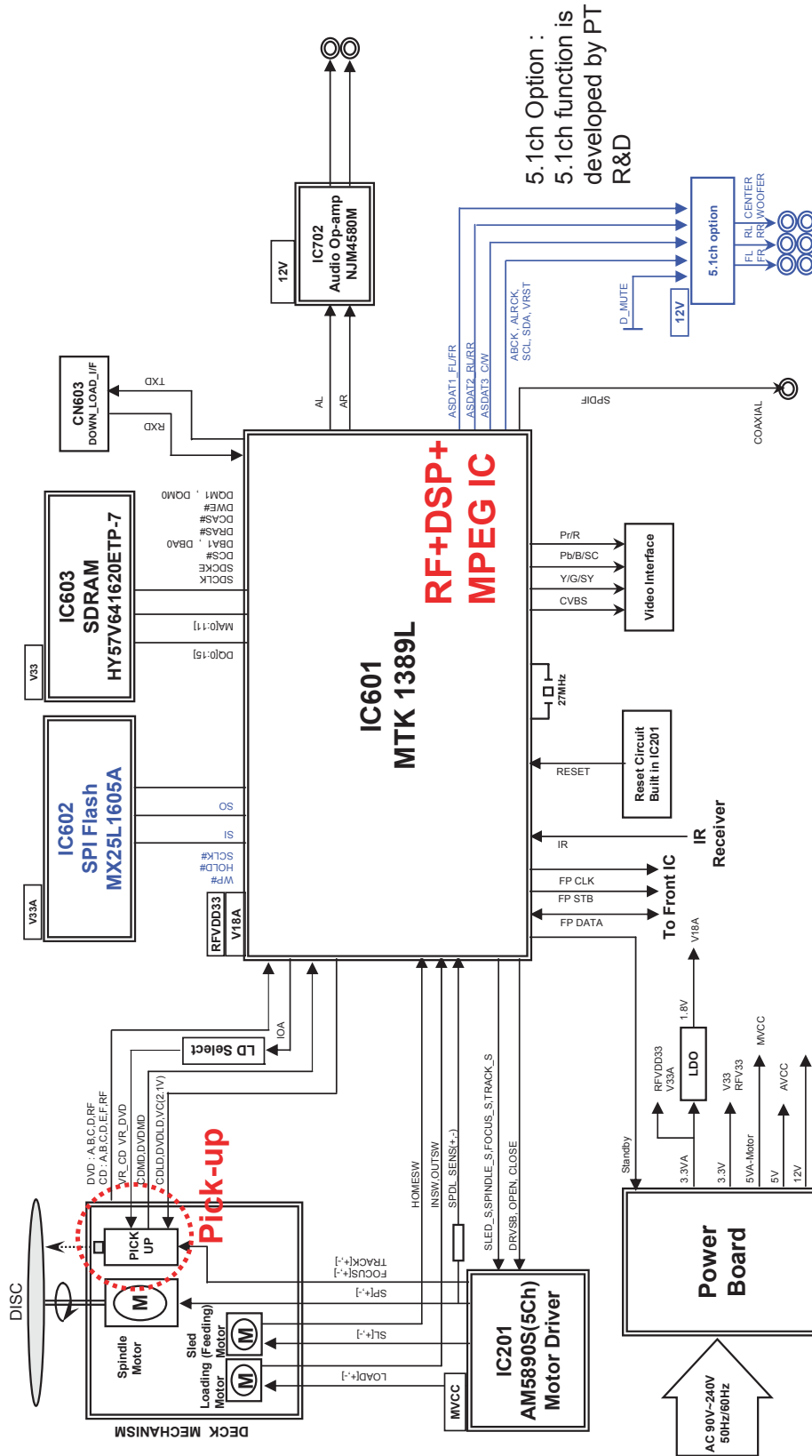

5.1ch Option :
5.1ch function is developed by PT R&D

2. POWER (SMPS) BLOCK DIAGRAM

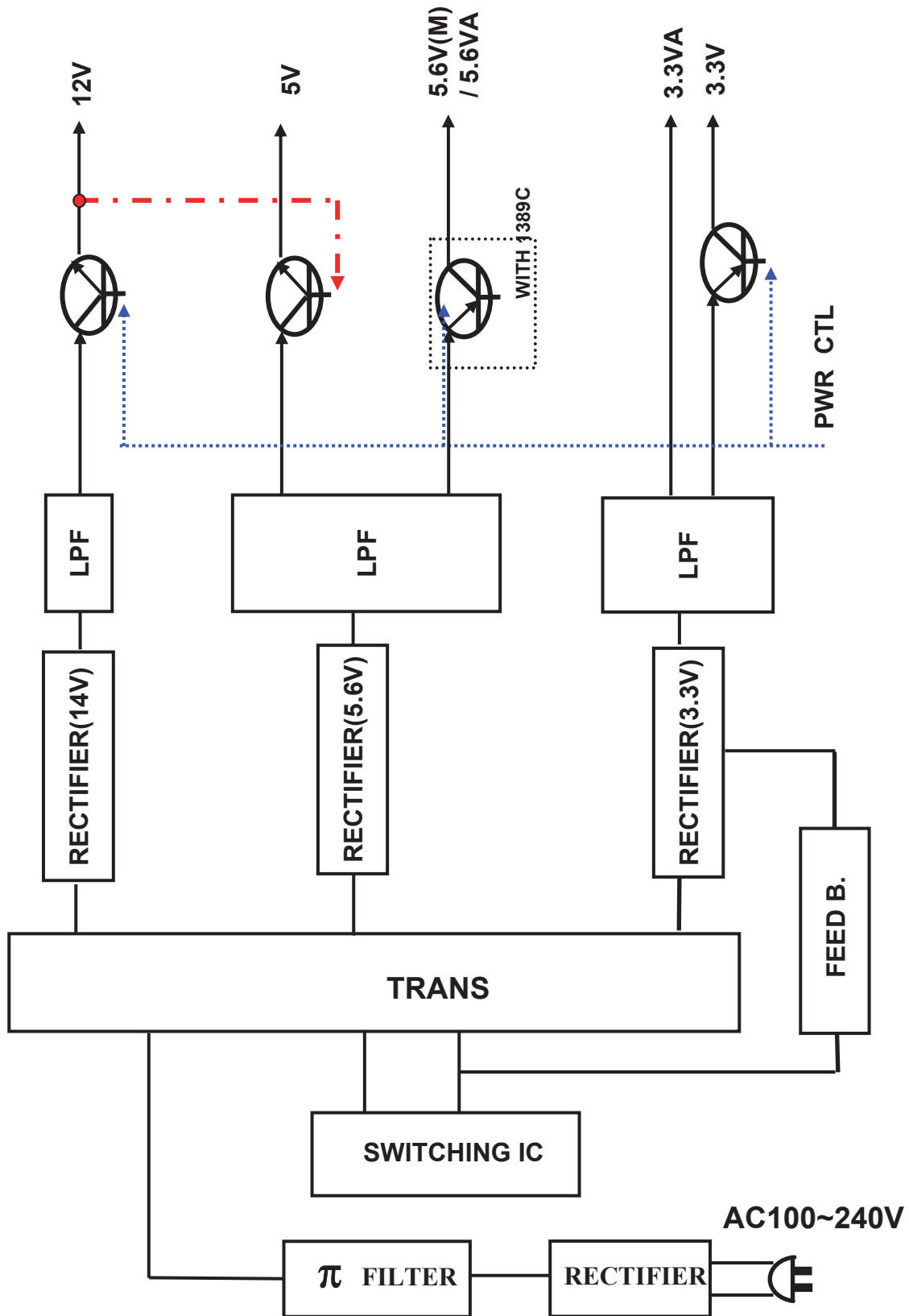

3. SYSTEM BLOCK DIAGRAM

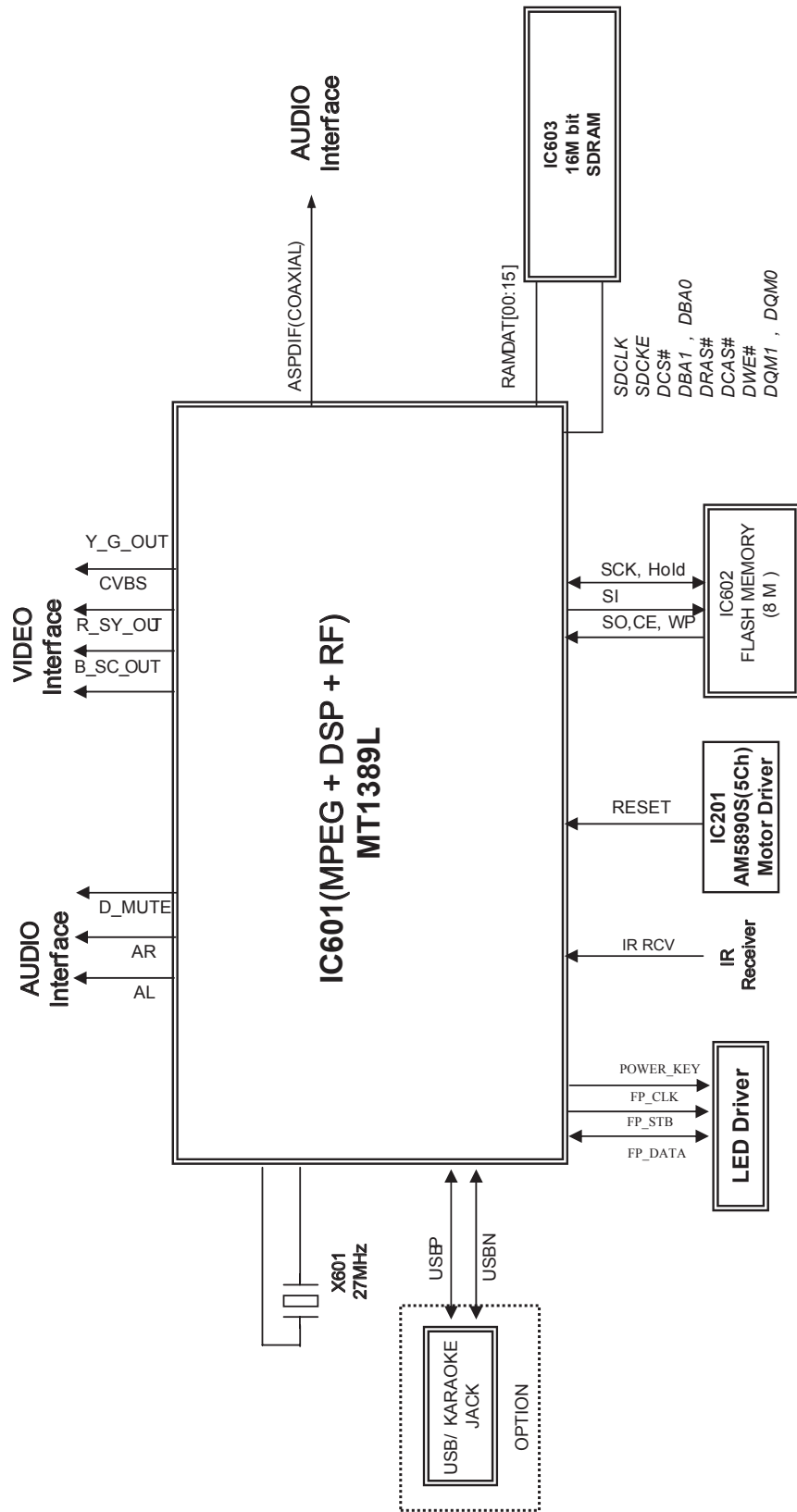

4. SERVO BLOCK DIAGRAM

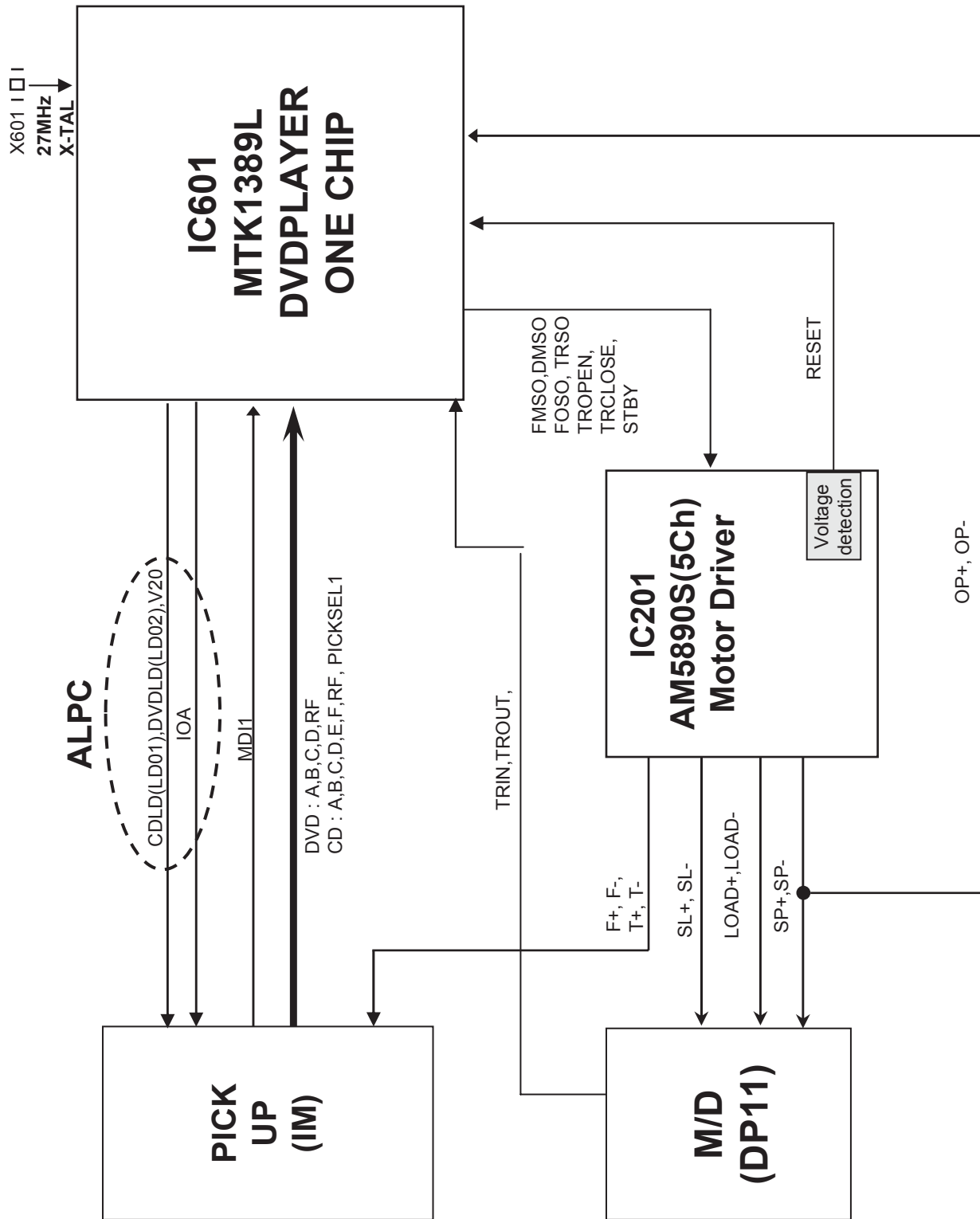

5. VIDEO BLOCK DIAGRAM

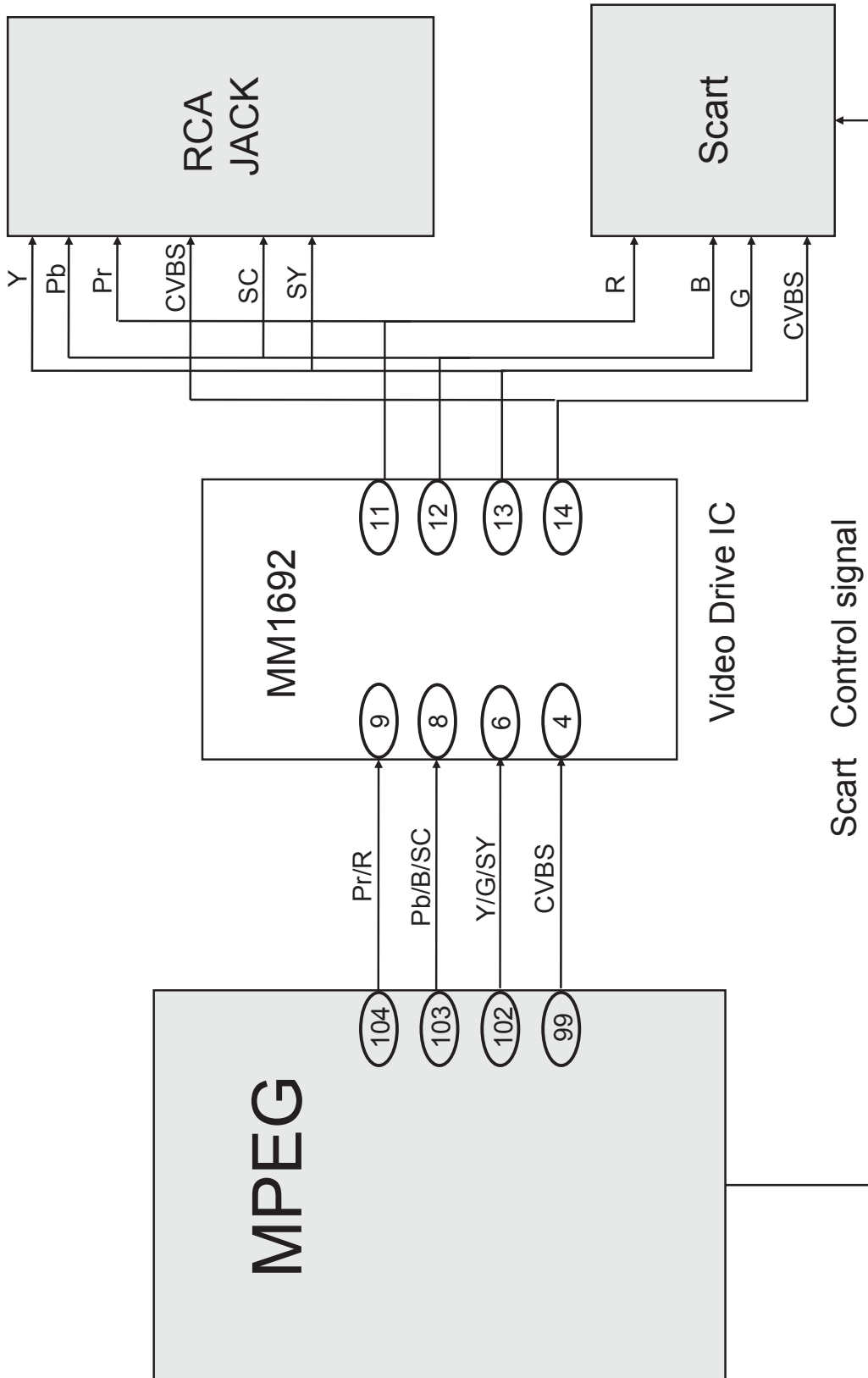

6. AUDIO BLOCK DIAGRAM

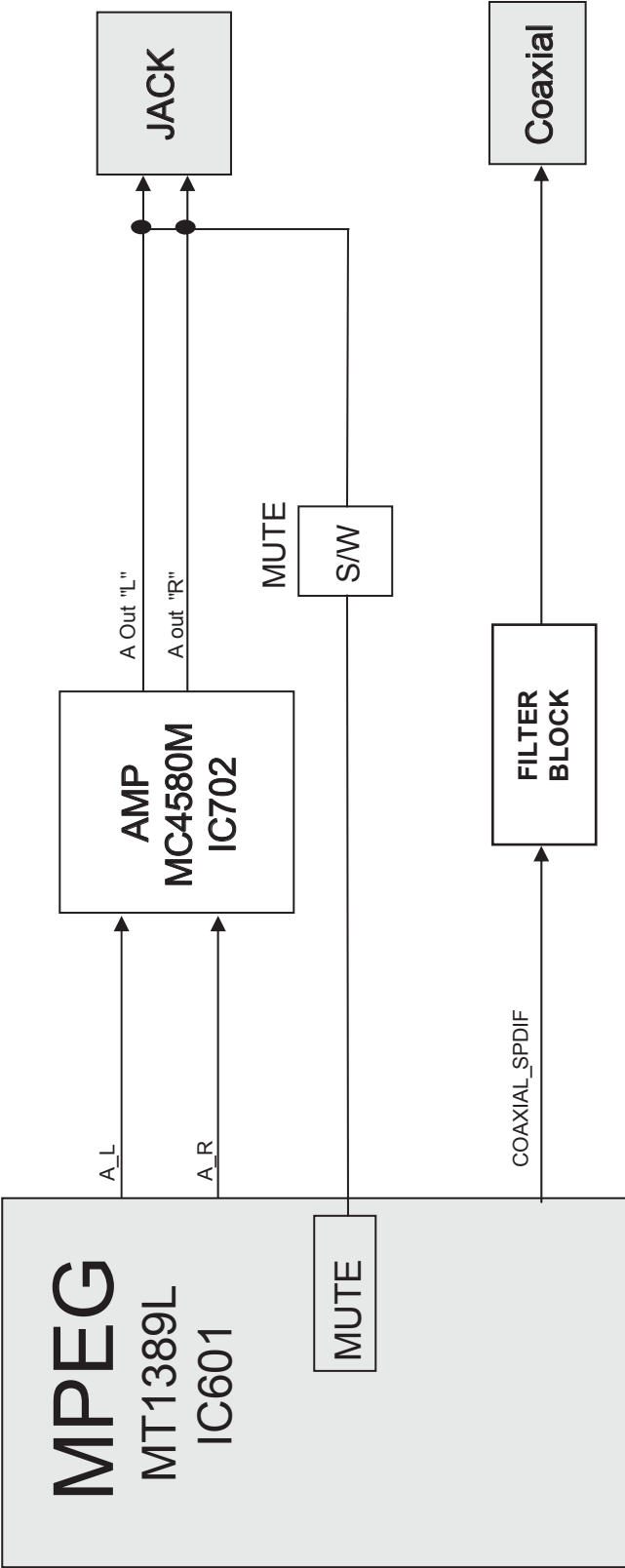

CIRCUIT DIAGRAMS

1. POWER (SMPS) CIRCUIT DIAGRAM

IMPORTANT SAFETY

WHEN SERVICING THIS CHASSIS, UNDER NO CIRCUMSTANCES SHOULD THE ORIGINAL DESIGN BE MODIFIED OR ALTERED WITHOUT PERMISSION FROM THE LG CORPORATION. ALL COMPONENTS SHOULD BE REPLACED ONLY WITH TYPES IDENTICAL TO THOSE IN THE ORIGINAL CIRCUIT. SPECIAL COMPONENTS ARE SHADED ON THE SCHEMATIC

FOR EASY IDENTIFICATION, THIS CIRCUIT DIAGRAM MAY OCCASIONALLY DIFFER FROM THE ACTUAL CIRCUIT USED. THIS WAY, IMPLEMENTATION OF THE LATEST SAFETY AND PERFORMANCE IMPROVEMENT CHANGES INTO THE SET IS NOT DELAYED UNTIL THE NEW SERVICE LITERATURE IS PRINTED.

NOTE :

- Shaded(■) parts are critical for safety. Replace only with specified part number.
- Voltages are DC-measured with a digital voltmeter during Play mode.

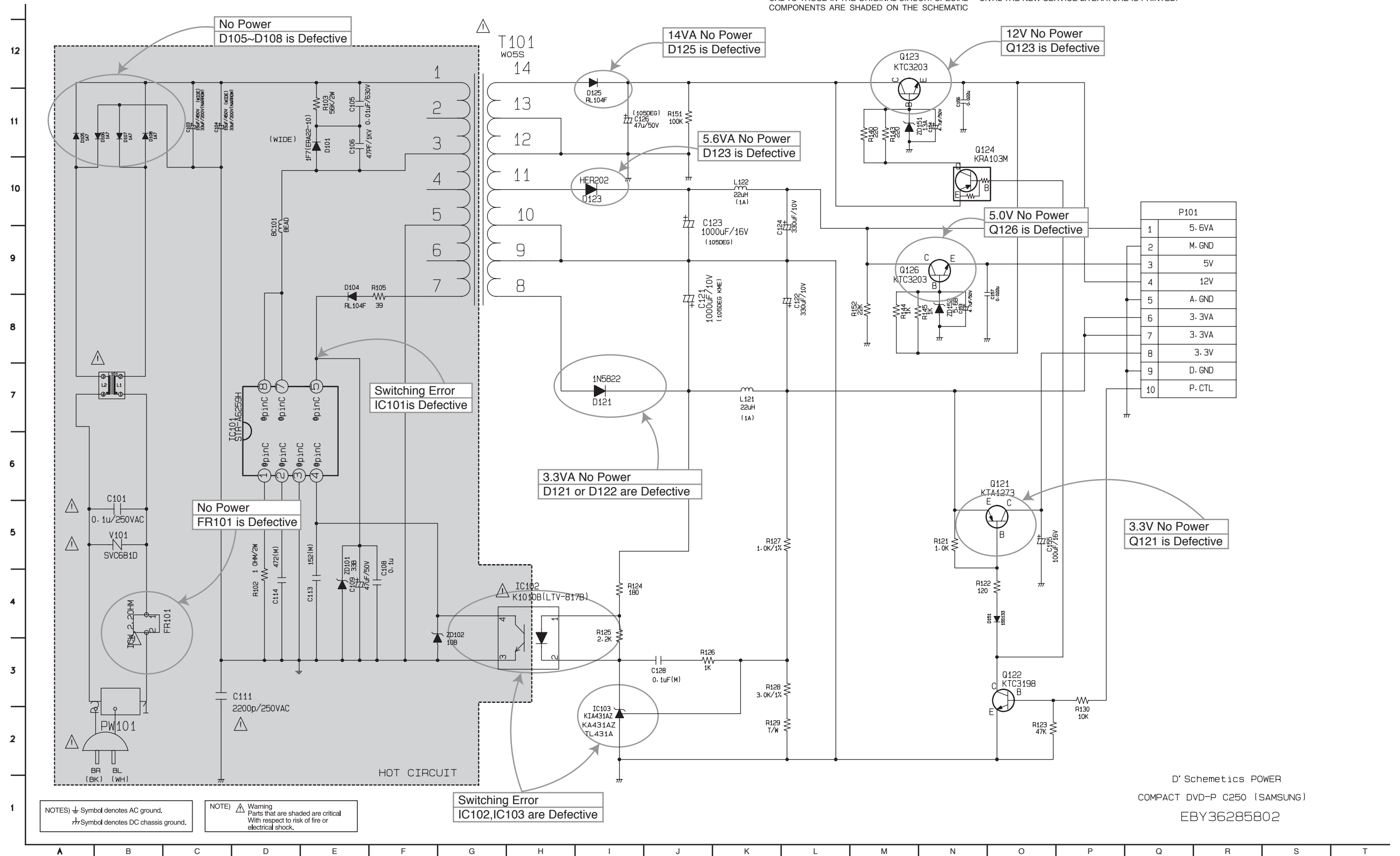

2. SYSTEM (MPEG) CIRCUIT DIAGRAM

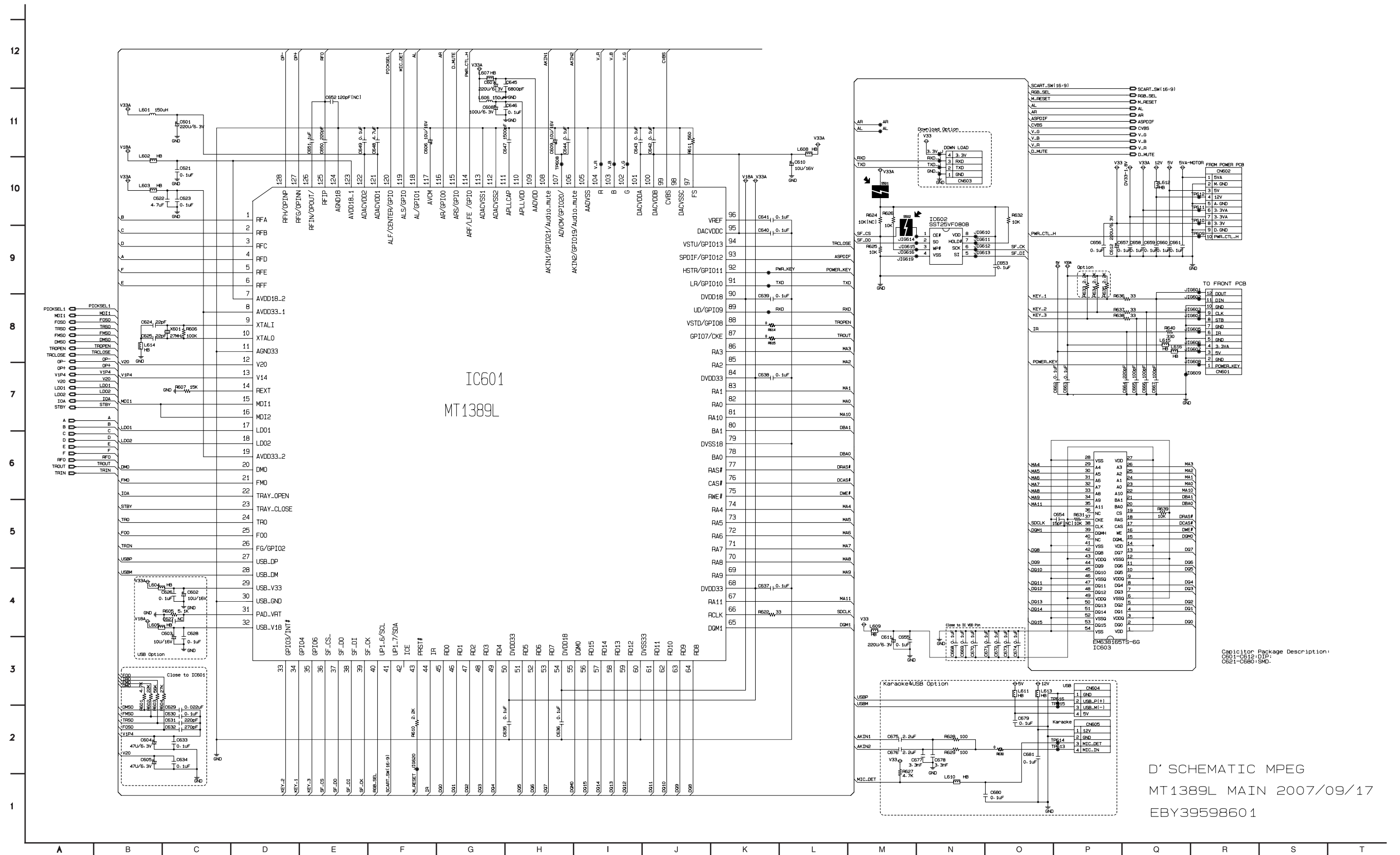

3. SERVO CIRCUIT DIAGRAM

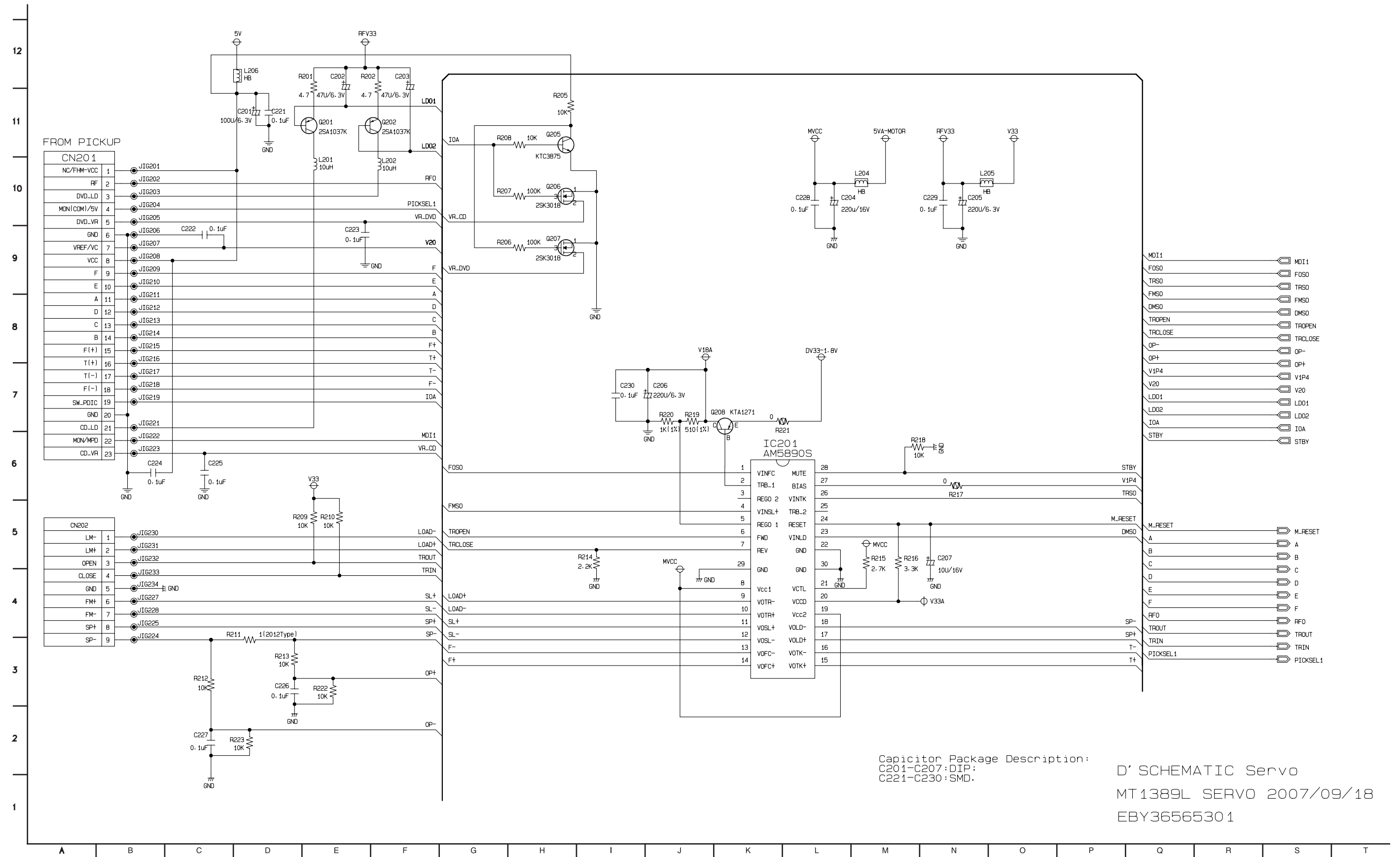

Capacitor Package Description:
 C201-C207:DIP:
 C221-C230:SMD.

D' SCHEMATIC Servo
 MT1389L SERVO 2007/09/18
 EBY36565301

4. AV (JACK) CIRCUIT DIAGRAM

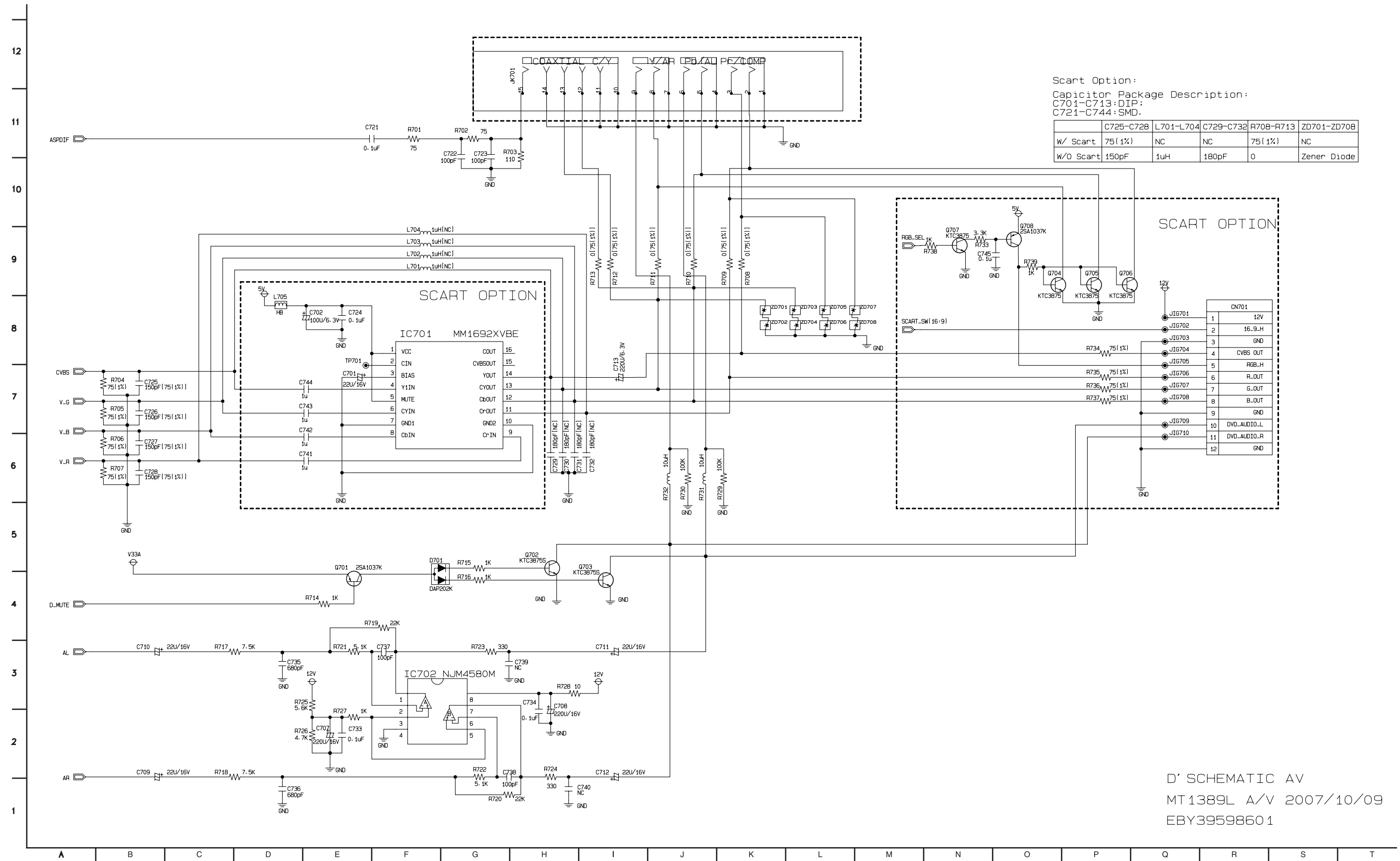

D' SCHEMATIC AV
 MT1389L A/V 2007/10/09
 EBY39598601

5. 5.1CH CIRCUIT DIAGRAM (OPTION)

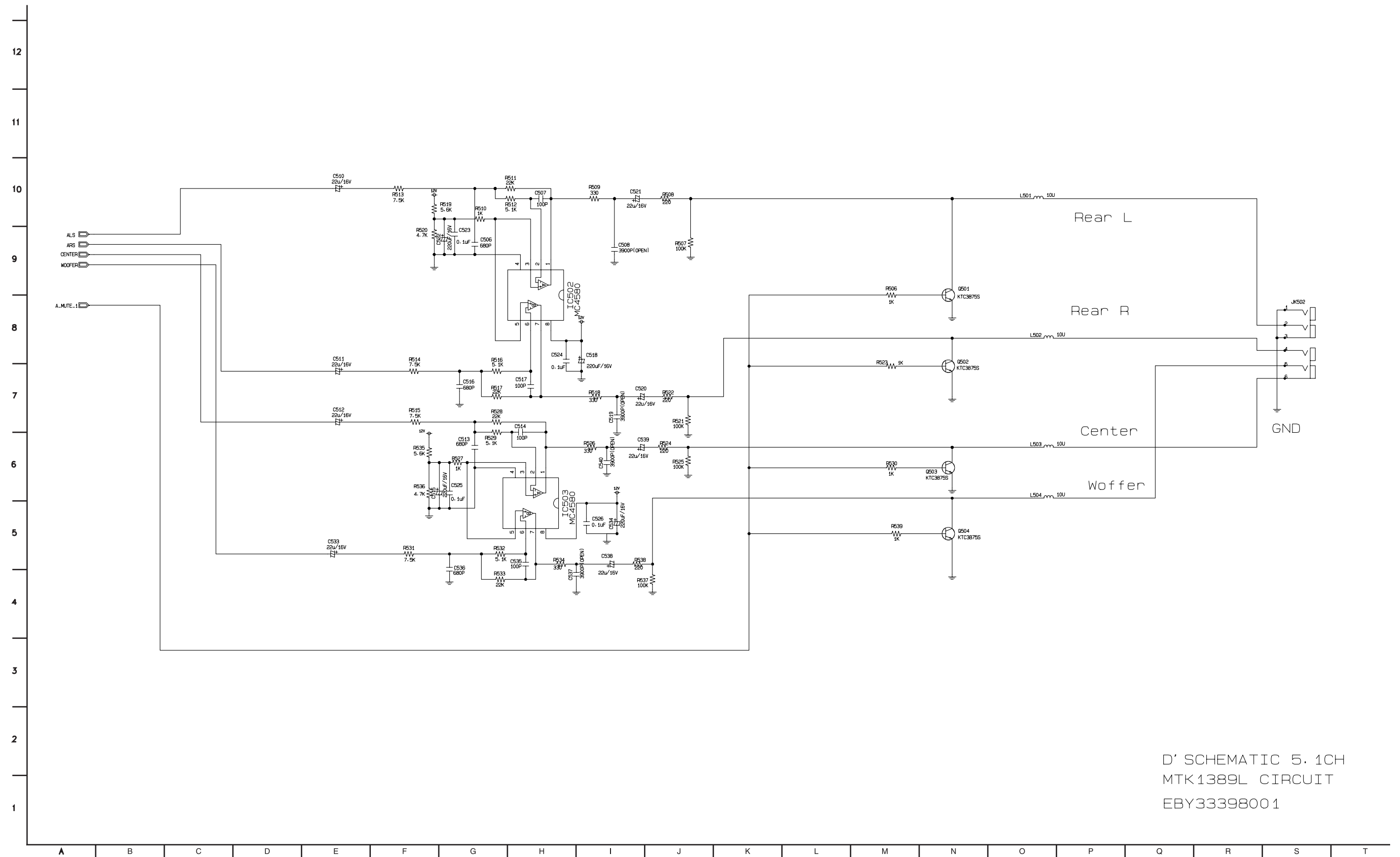

D' SCHEMATIC 5.1CH
 MTK1389L CIRCUIT
 EBY33398001

6. KARAOKE & USB CIRCUIT DIAGRAM (OPTION)

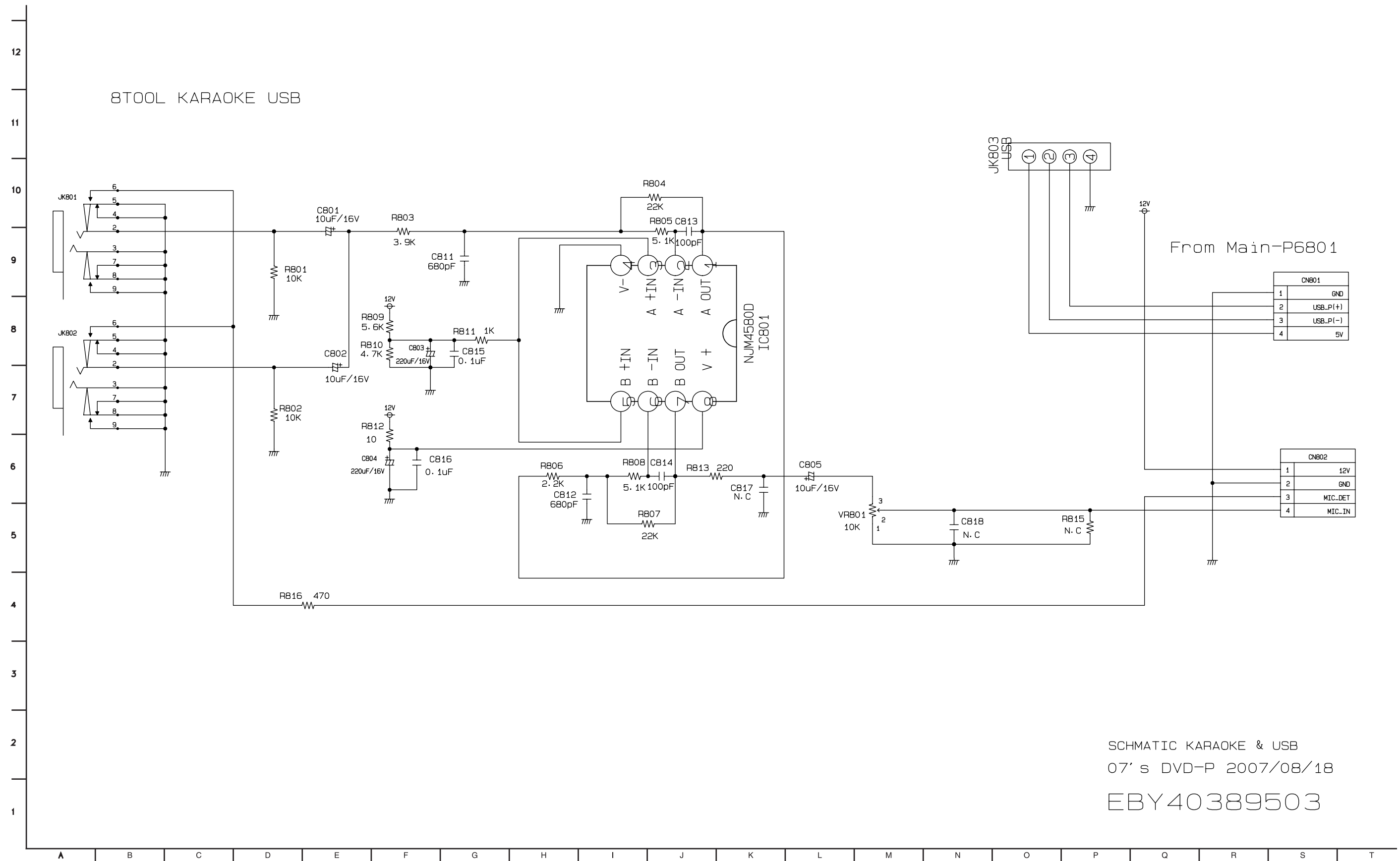

7. KEY CIRCUIT DIAGRAM

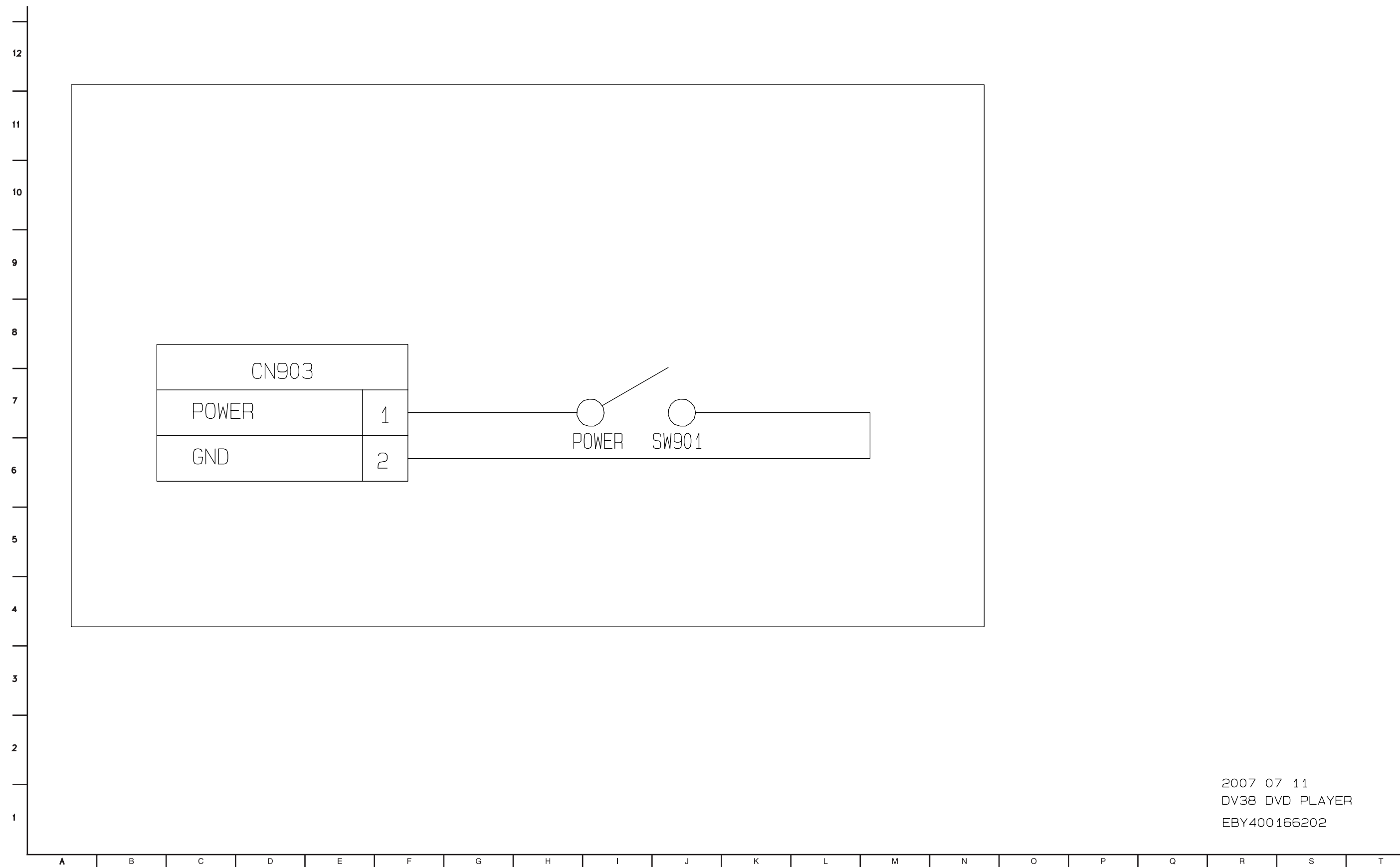

2007 07 11
 DV38 DVD PLAYER
 EBY400166202

8. TIMER CIRCUIT DIAGRAM

8-1. 4 TOOL

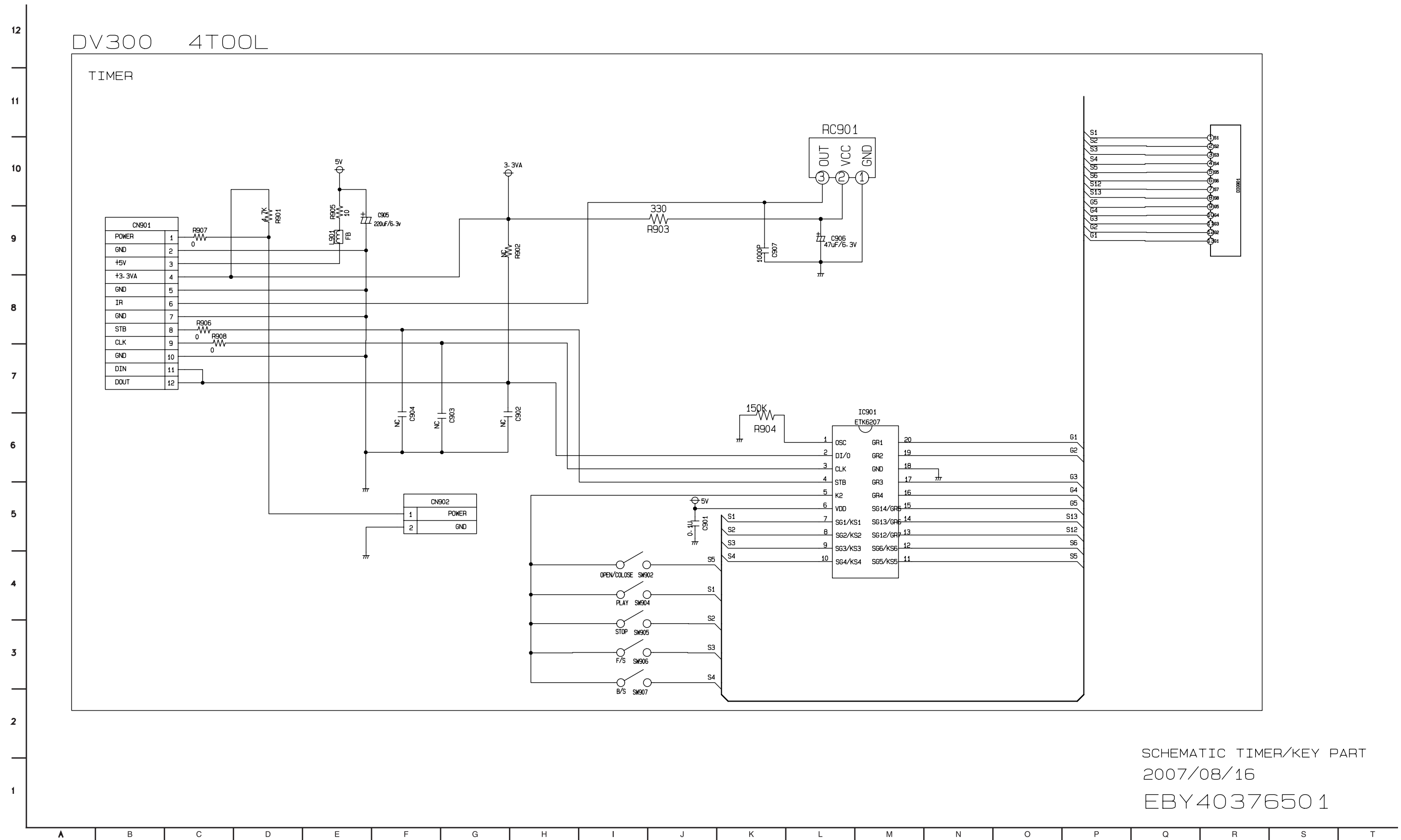

SCHEMATIC TIMER/KEY PART
 2007/08/16
 EBY4037650 1

8-2. 5 TOOL

DV300 5TOOL
TIMER

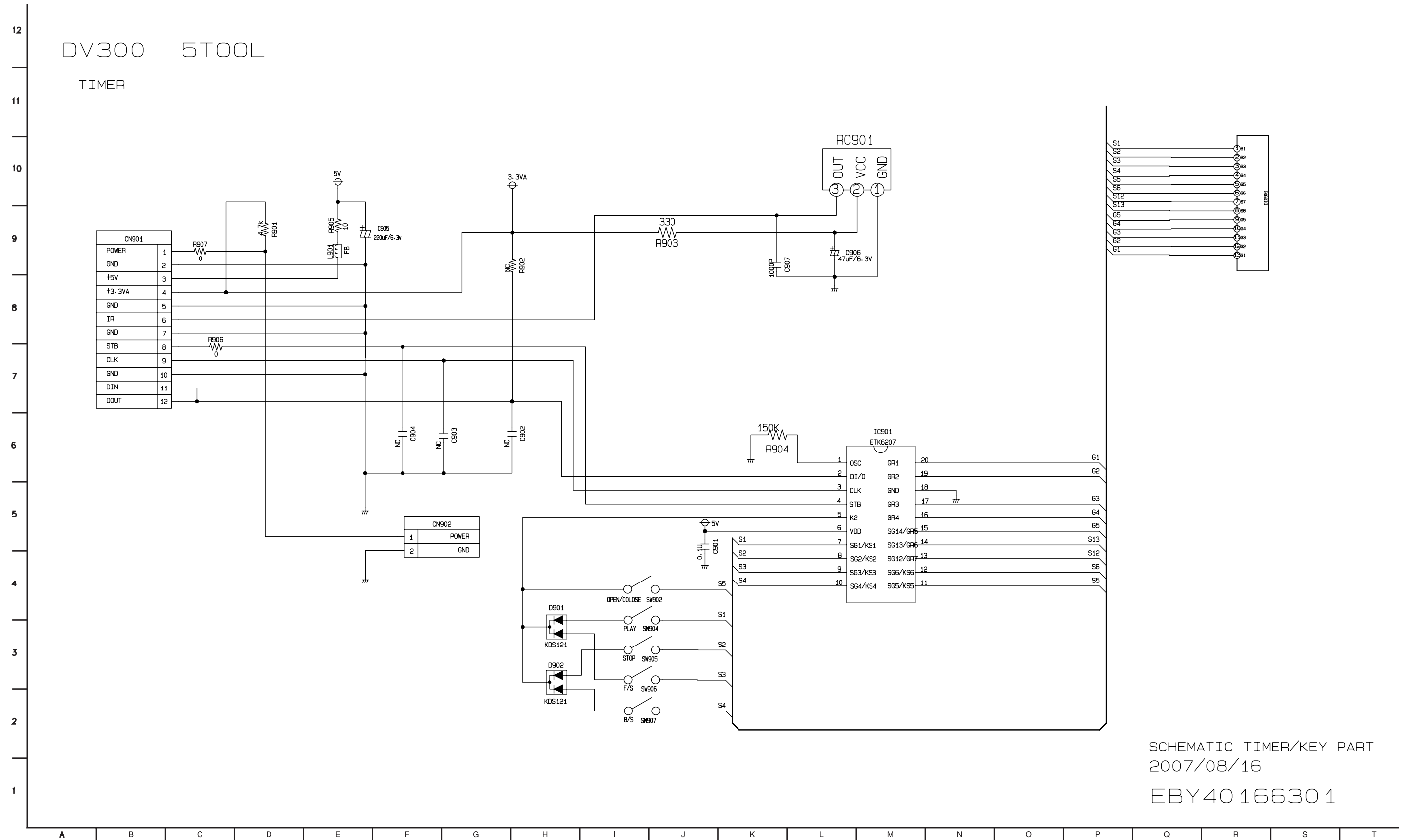

SCHEMATIC TIMER/KEY PART
2007/08/16

EBY40166301

8-3. 8 TOOL

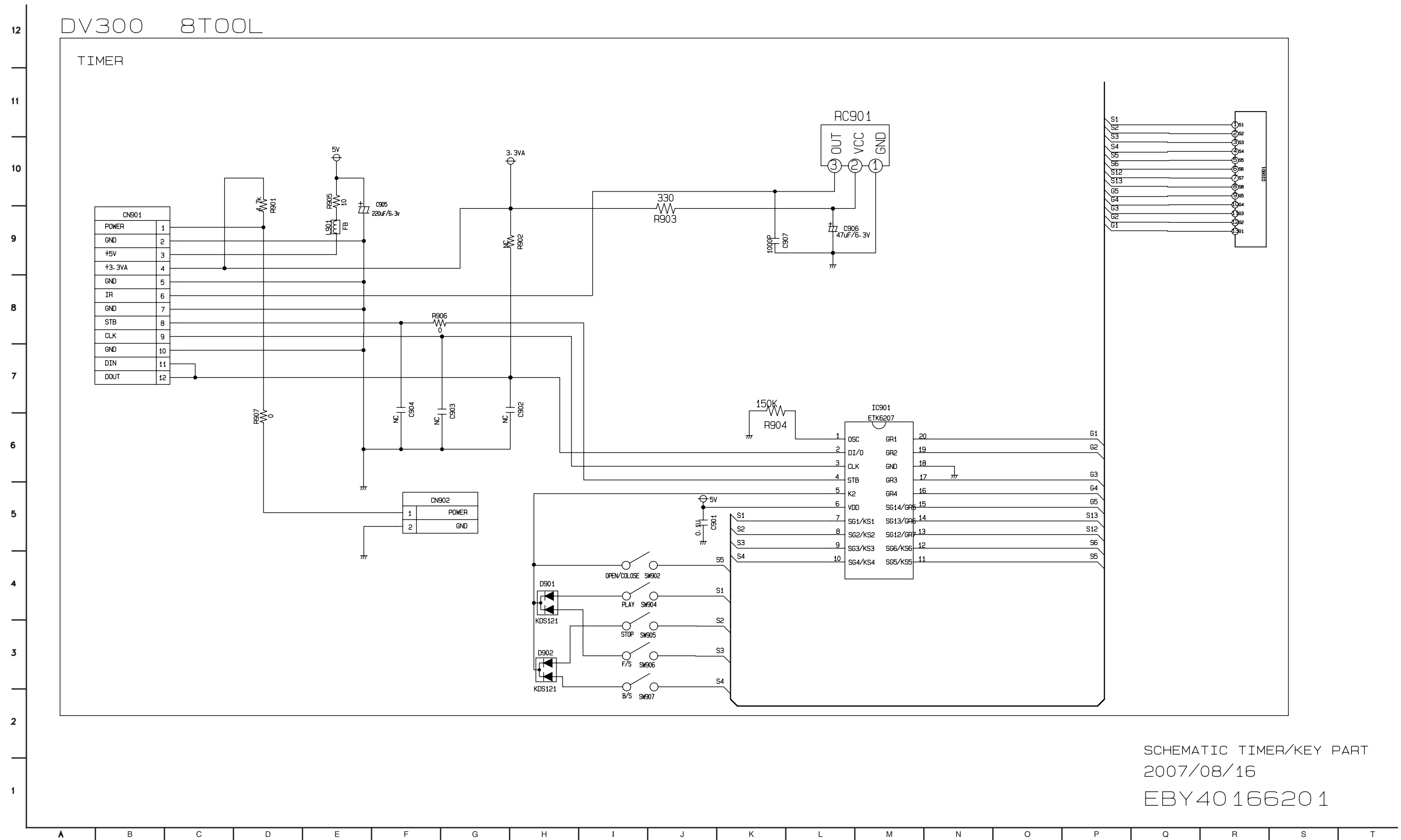

SCHEMATIC TIMER/KEY PART
 2007/08/16
 EBY40166201

8-4. 9 TOOL

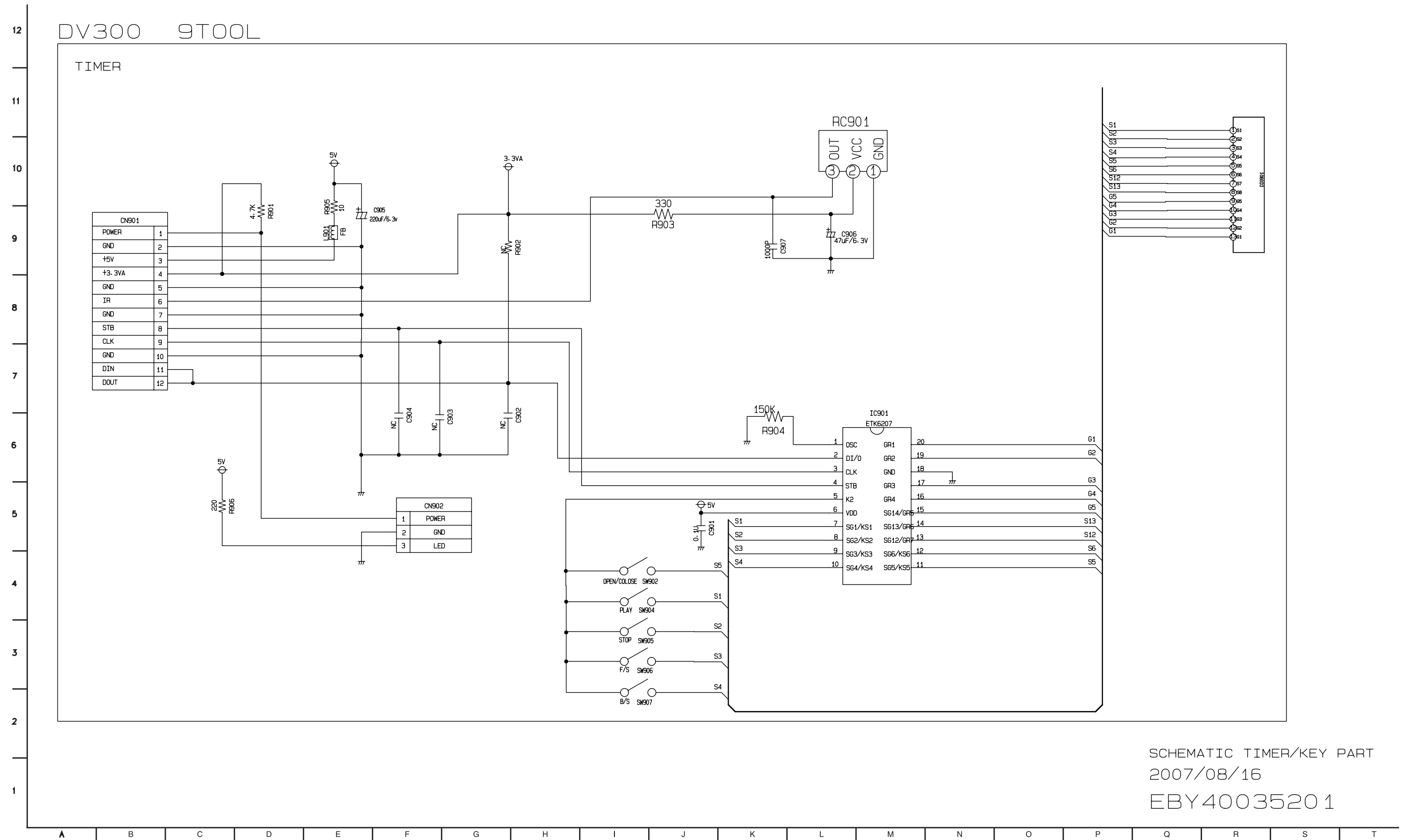

SCHEMATIC TIMER/KEY PART
2007/08/16
EBY4003520 1

• CIRCUIT VOLTAGE CHART

PIN	No Disc	Play	PIN	No Disc	Play	PIN	No Disc	Play	PIN	No Disc	Play	PIN	No Disc	Play
IC201			23	0.009	3.13	77	3.201	3.196	2	1.416	1.247	47	0.002	0.002
1	1.405	1.422	24	1.407	0.002	78	0.922	0.919	3	3.299	3.294	48	1.351	0.156
2	1.812	1.797	25	1.387	1.453	79	0.004	0.004	4	0.001	0.001	49	0.081	1.184
3	2.554	2.873	26	0.001	0.001	80	0.005	0.017	5	0.013	0.014	50	0.001	0.02
4	1.409	1.421	27	0.024	0.024	81	0.012	0.071	6	0.012	0.014	IC701		
5	1.262	1.254	28	0.024	0.024	82	0.08	0.697	7	3.302	3.295	1	4.7	4.69
6	0.01	0.01	29	3.29	2.917	83	1.052	1.903	2	2.22	2.22	2	2.22	2.22
7	0.01	0.011	30	0.002	0.082	84	3.302	3.293	3	2.35	2.35	3	2.35	2.35
8	6.445	5.57	31	0.82	0.819	85	1.025	1.871	4	1.76	1.81	4	1.76	1.81
9	0.001	0.002	32	1.859	1.859	86	1.024	1.432	5	4.71	4.73	5	4.71	4.73
10	0.001	0.002	33	0.185	0.19	87	2.869	2.848	6	1.76	1.79	6	1.76	1.79
11	3.216	2.832	34	0.185	0.189	88	0.01	0.011	7	0	0	7	0	0
12	3.216	2.917	35	2.232	2.229	89	3.288	3.278	8	2.22	2.22	8	2.22	2.22
13	3.215	2.776	36	3.284	3.166	90	1.876	1.871	9	2.2	2.19	9	2.2	2.19
14	3.215	2.931	37	0.004	0.013	91	3.296	3.288	10	0	0	10	0	0
15	3.222	2.866	38	3.298	3.244	92	3.186	3.278	11	2.19	2.2	11	2.19	2.2
16	3.223	2.872	39	0.013	0.014	93	1.545	1.537	12	2.18	2.17	12	2.18	2.17
17	3.207	4.331	40	0.029	0.044	94	0.012	0.011	13	1.84	1.97	13	1.84	1.97
18	3.207	1.212	41	0.002	3.279	95	3.279	3.285	14	1.82	1.92	14	1.82	1.92
19	6.447	3.464	42	3.31	0.013	96	0.002	0.002	15	1.78	1.88	15	1.78	1.88
20	3.302	3.297	43	3.32	3.281	97	1.224	1.221	16	2.2	2.2	16	2.2	2.2
21	6.445	0.112	44	3.03	3.029	98	0.002	0.002	IC702			1	5.067	5.669
22	0.001	0.001	45	0.884	0.004	99	0.883	0.459	2	5.68	5.681	2	5.68	5.681
23	1.412	2.847	46	0.831	0.587	100	3.298	3.284	3	5.679	5.679	3	5.679	5.679
24	3.292	3.447	47	0.98	0.567	101	3.298	3.284	4	0.002	0.001	4	0.002	0.001
25	6.419	2.015	48	0.571	0.522	102	0.002	0.002	5	5.681	5.681	5	5.681	5.681
26	2.254	1.41	49	0.745	0.746	103	0.002	0.002	6	5.683	5.684	6	5.683	5.684
27	1.409	1.871	50	3.305	3.295	104	0.001	0.003	7	5.671	5.672	7	5.671	5.672
28	0.009	3.128	51	1.141	0.149	105	0.002	0.002	8	12.397	12.397	8	12.397	12.397
29	0	0	52	0.352	0.766	106	0.002	0.02						
30	0	0	53	1.258	0.897	107	3.273	0.015						
IC601			54	1.865	1.864	108	3.274	0.003						
1	2.033	2.077	55	2.812	2.963	109	3.299	3.259						
2	2.03	2.076	56	0.121	0.882	110	3.293	3.285						
3	2.027	2.065	57	1.26	1.122	111	2.701	1.942						
4	2.027	2.068	58	0.914	0.097	112	0.002	0.003						
5	2.026	2.071	59	0.949	0.153	113	0.002	0.002						
6	2.024	2.065	60	0.002	0.006	114	3.237	3.229						
7	1.876	1.88	61	0.844	0.436	115	3.263	3.255						
8	3.287	3.265	62	0.788	0.513	116	1.627	1.619						
9	0.795	0.737	63	0.828	0.365	117	1.393	1.5						
10	0.925	0.72	64	0.803	0.625	118	1.632	1.39						
11	0.002	0.002	65	2.572	1.906	119	3.276	3.262						
12	2.024	2.026	66	2.312	2.458	120	0.059	0.013						
13	1.413	1.409	67	0.385	0.021	121	3.269	3.258						
14	0.591	0.59	68	3.304	3.294	122	3.269	3.258						
15	0.001	0.192	69	0.032	0.031	123	1.885	1.859						
16	0.002	0.191	70	0.032	0.036	124	0.004	0.003						
17	3.283	2.748	71	1.166	1.293	125	0.983	0.983						
18	3.284	2.285	72	1.546	1.541	126	2.891	1.07						
19	3.287	3.284	73	1.478	1.107	127	2.535	1.32						
20	3.288	2.191	74	1.042	1.033	128	3.097	1.765						
21	1.404	1.47	75	3.254	3.247	IC602								
22	0.014	0.013	76	3.064	3.057	1	0.215	0.282						
						2	0.997	0.59						

DC VOLTMETER MEASUREMENT METODS

Condenser	Capacitor	WV (Withstanding Voltage)	PLAY	
			+A	-/K
C601	220uF	6.3V	3.26	0.00
C602	10uF	10V	2.92	0.01
C603	10uF	10V	1.86	0.00
C604	47uF	6.3V	2.03	0.00
C605	47uF	6.3V	1.41	0.00
C606	10uF	16V	1.39	0.00
C607	220uF	6.3V	3.26	0.00
C608	100uF	6.3V	3.28	0.00
C609	10uF	16V	0.20	0.00
C610	10uF	16V	3.29	0.00
C611	220uF	6.3V	3.28	0.00
C612	220uF	6.3V	3.29	0.01
C201	100uF	6.3V	4.99	0.00
C202	47uF	6.3V	3.28	2.75
C203	47uF	6.3V	3.28	2.28
C204	220uF	16V	5.77	0.00
C205	220uF	6.3V	3.28	0.00
C206	220uF	6.3V	1.90	0.00
C207	10uF	16V	3.29	0.00
C708	220uF	16V	12.42	0.00
C709	22uF	16V	5.68	1.62
C701	22uF	16V	2.34	0.00
C702	100uF	6.3V	4.69	0.00
C707	220uF	16V	5.69	0.00
C710	22uF	16V	5.69	1.62
C711	22uF	16V	5.68	0.10
C712	22uF	16V	5.68	0.00
C713	220uF	6.3V	1.96	1.83

TR	PLAY		
	E/S	C/D	B/G
Q201	3.28	0.04	2.75
Q202	3.02	2.19	2.28
Q205	0.00	0.01	4.94
Q206	0.01	4.98	0.00
Q207	0.01	0.19	0.01
Q208	2.48	1.91	1.81
Q701	0.00	-1.90	3.20
Q702	0.01	0.00	-0.76
Q703	-0.01	0.00	-1.30
Q704	0.74	0.06	0.00
Q705	0.74	0.07	0.00
Q706	0.74	0.08	0.00
Q707	0	0.06	0.61
Q708	4.04	4.72	4.75

PRINTED CIRCUIT BOARD DIAGRAMS

1. MAIN P.C.BOARD (TOP VIEW)

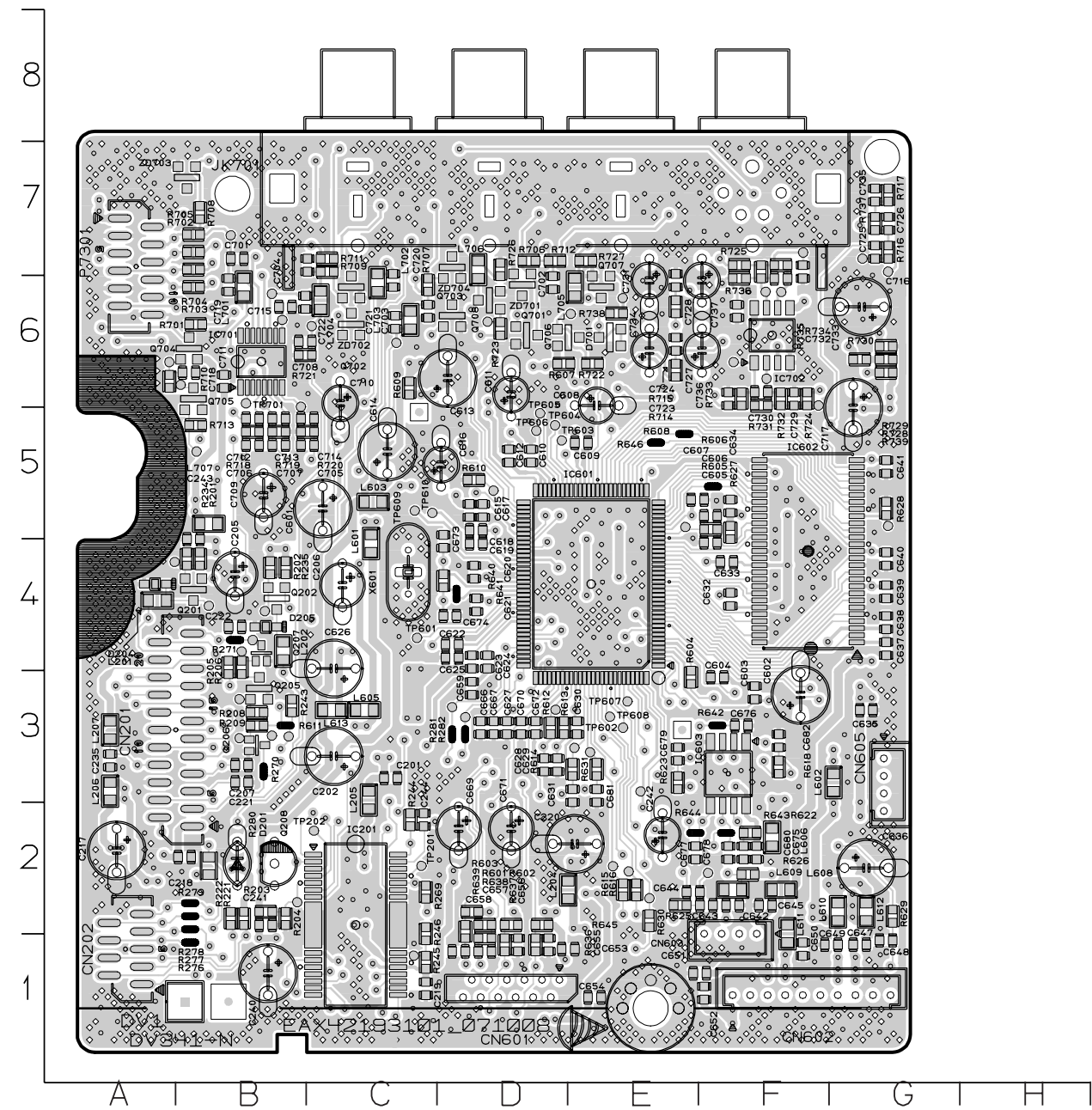

(BOTTOM VIEW)

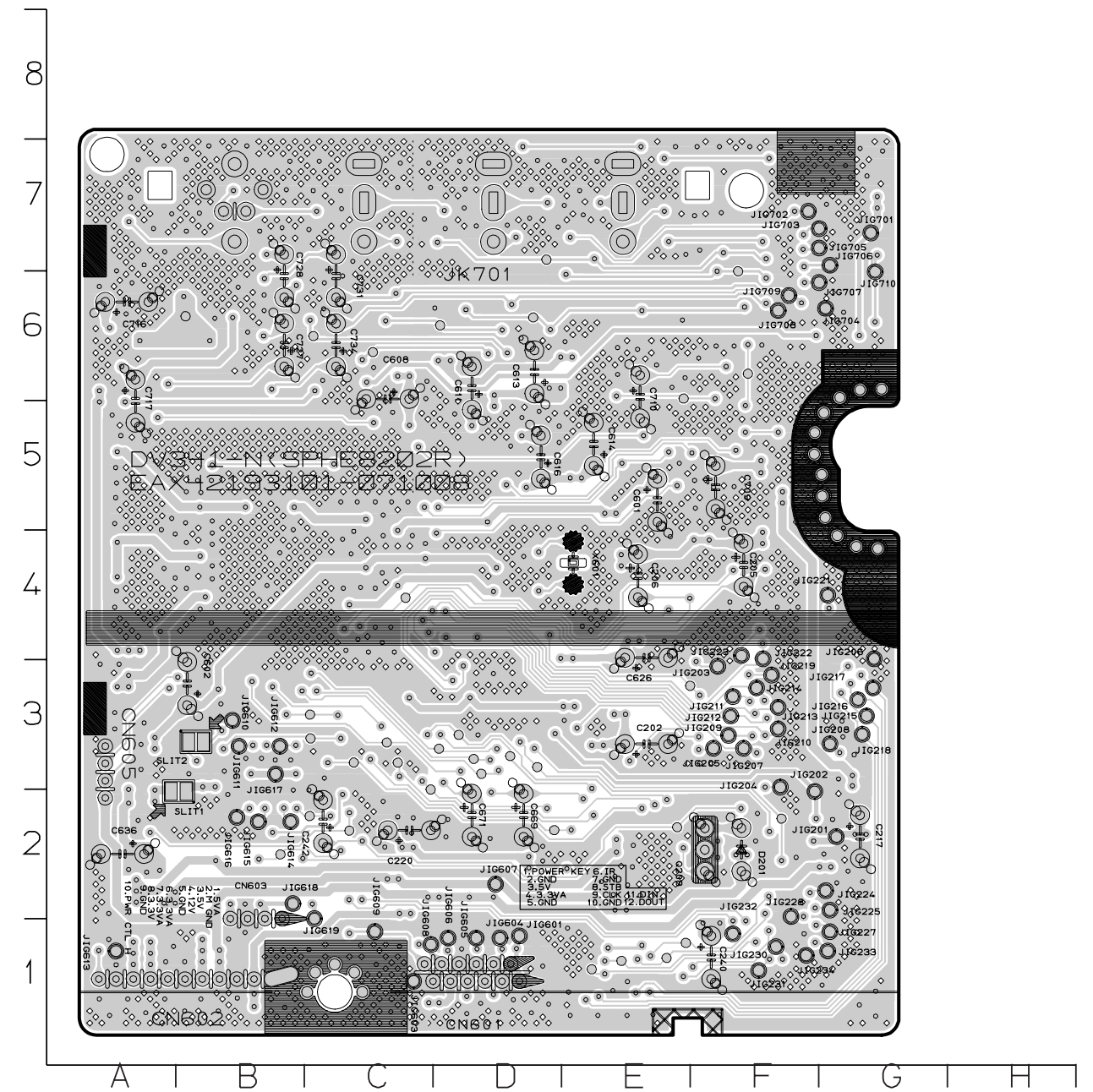

2. POWER (SMPS) P.C.BOARD (TOP VIEW)

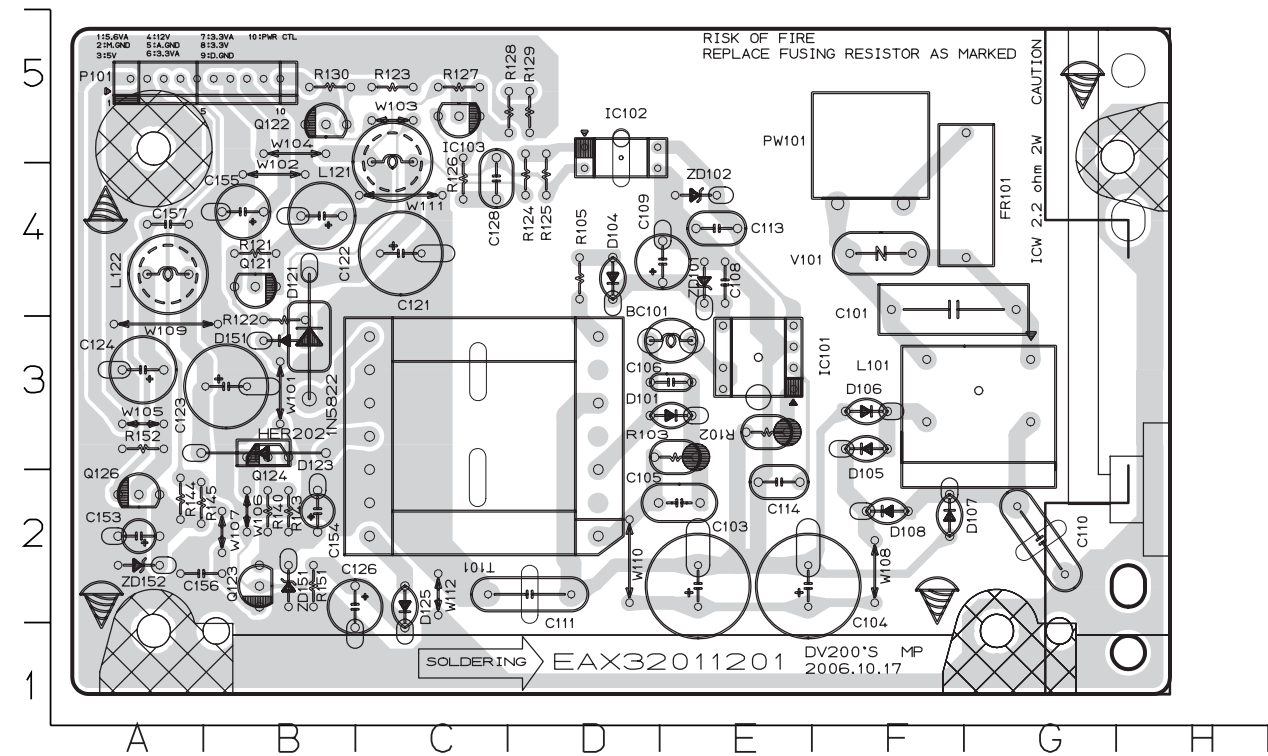

(BOTTOM VIEW)

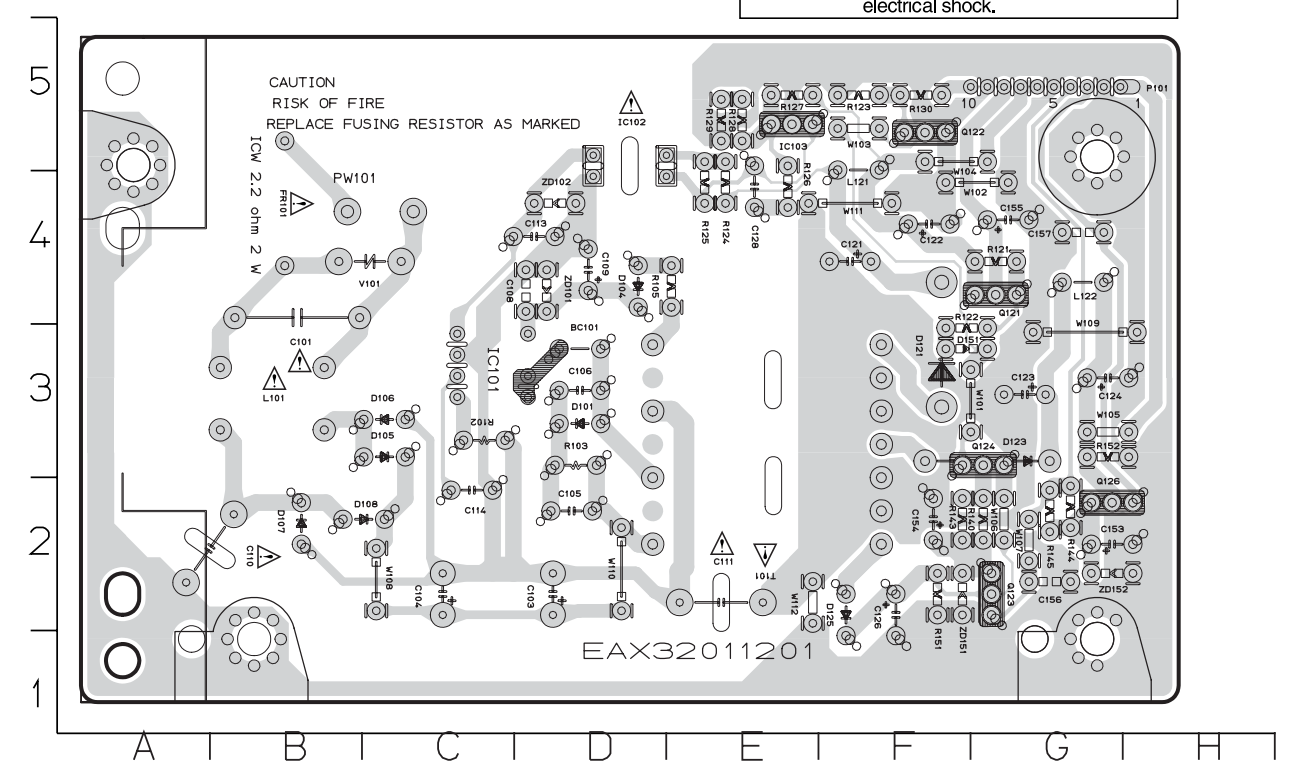

(NOTE) ⚠ Warning
Parts that are shaded
with respect to risk of fire or
electrical shock.

3. 5.1CH & SCART P.C.BOARD (OPTIONAL PART) (TOP VIEW)

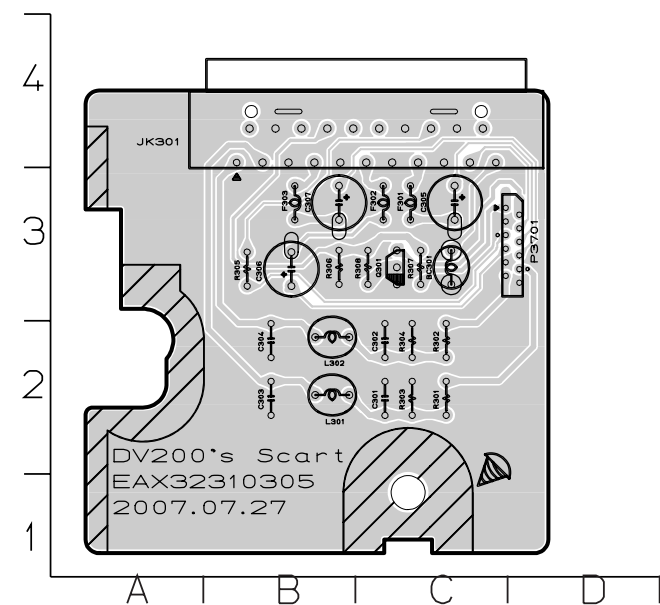

(BOTTOM VIEW)

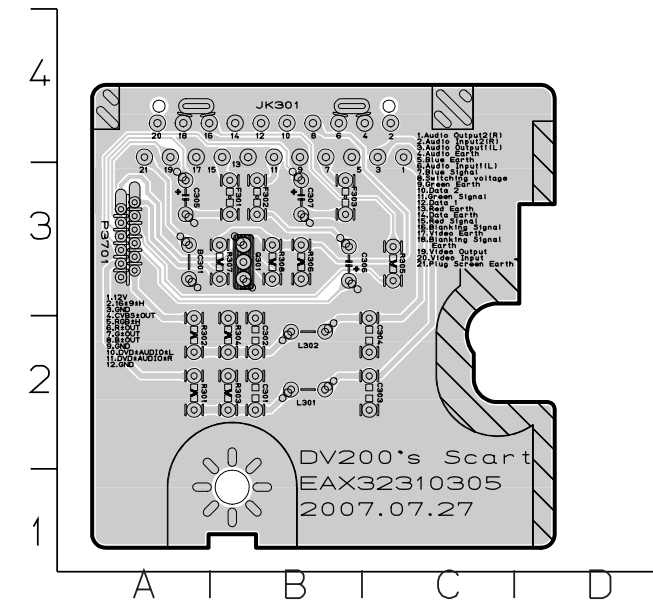

4. KARAOKE & USB P.C.BOARD (OPTIONAL PART)

4-1. 4 TOOL (TOP VIEW)

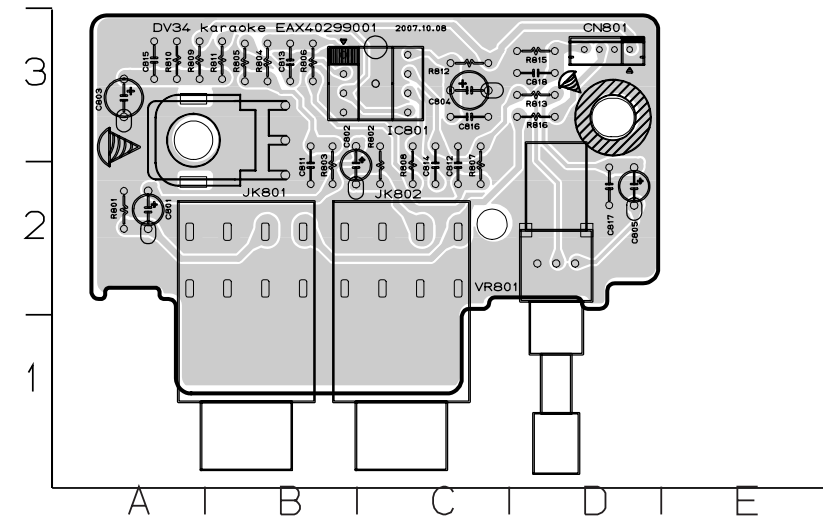

(BOTTOM VIEW)

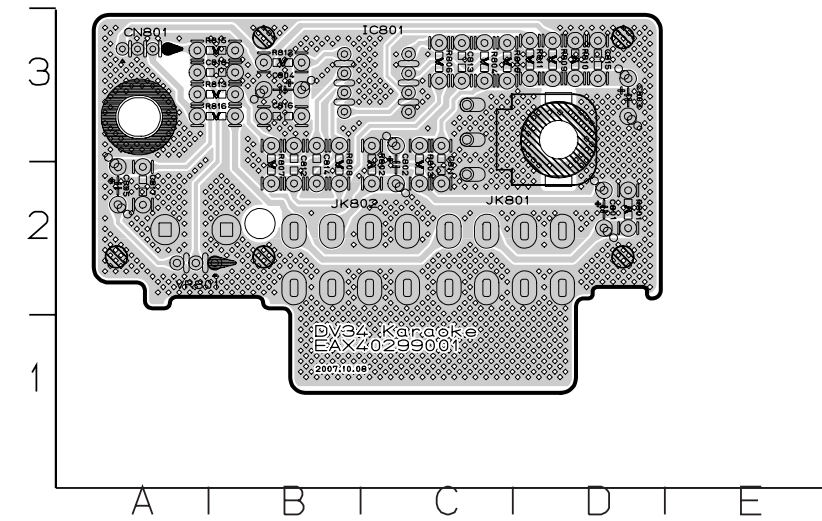

4-2. 5 TOOL (TOP VIEW)

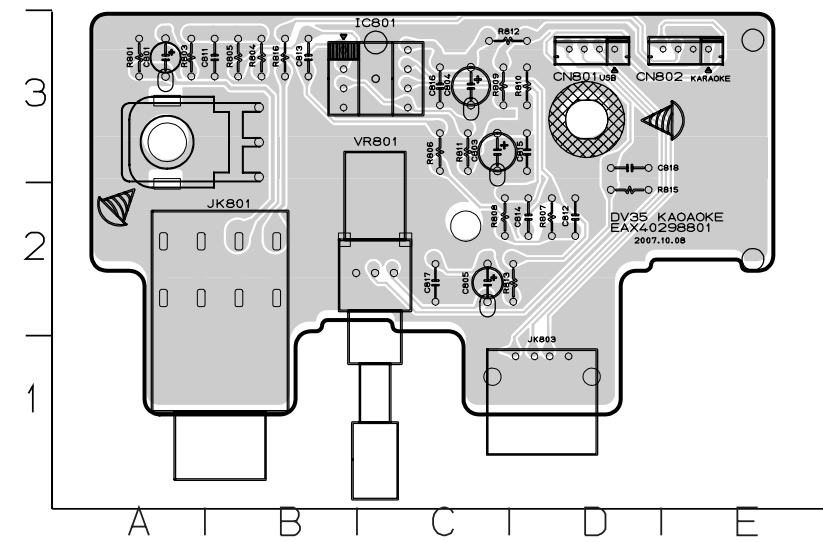

(BOTTOM VIEW)

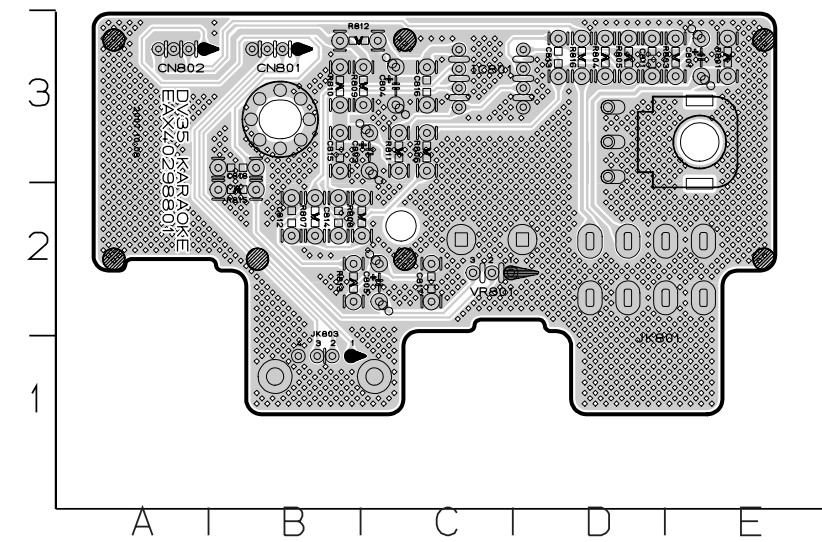

**4-3. 8 TOOL
(TOP VIEW)**

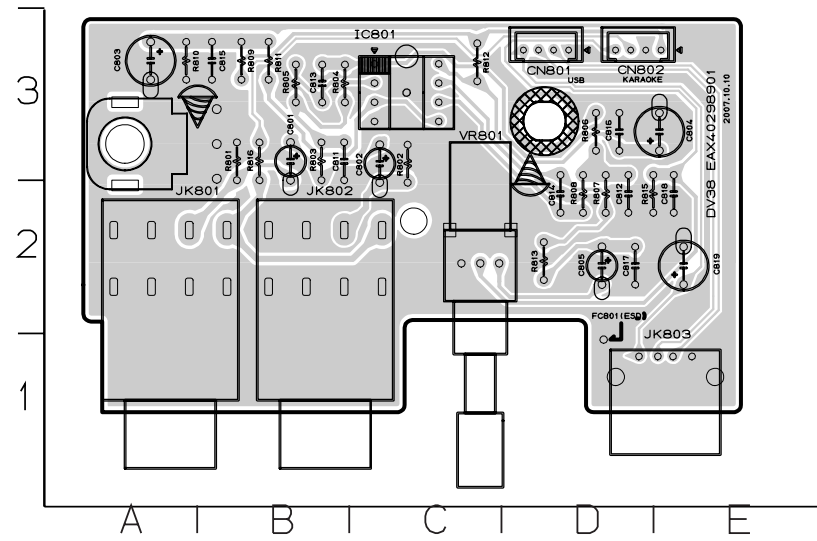

(BOTTOM VIEW)

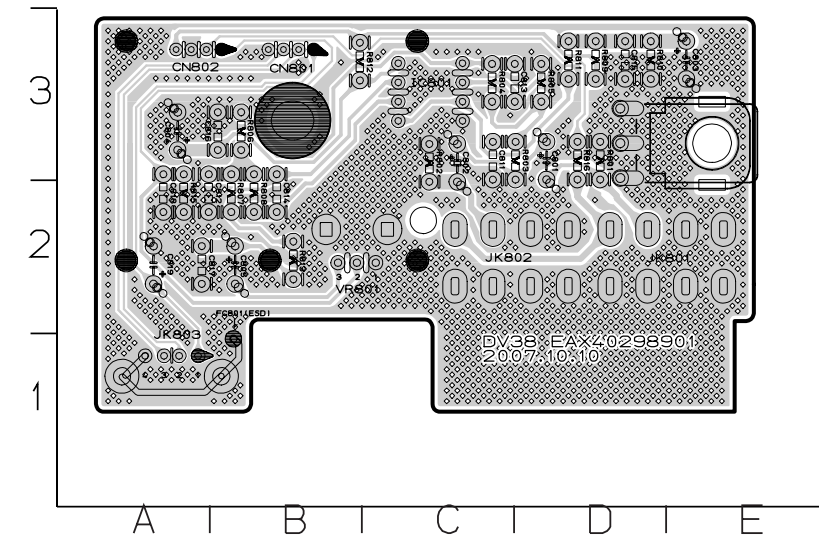

**4-4. 9 TOOL
(TOP VIEW)**

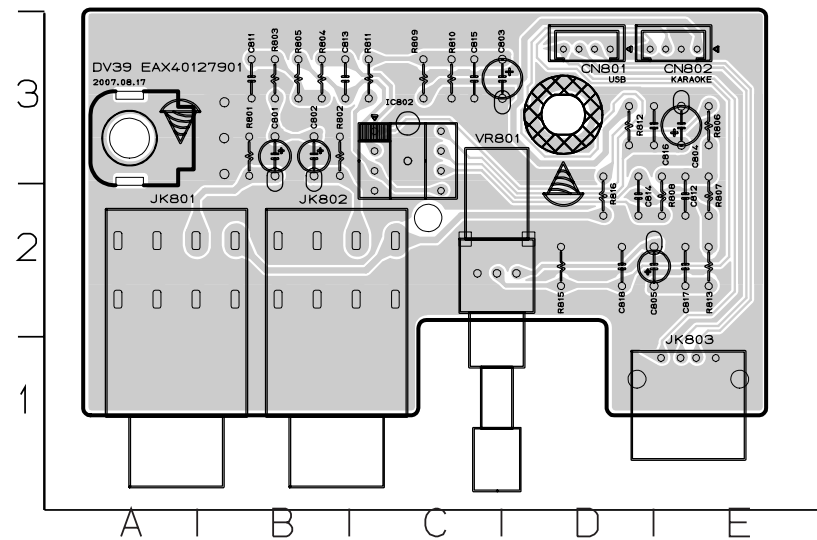

(BOTTOM VIEW)

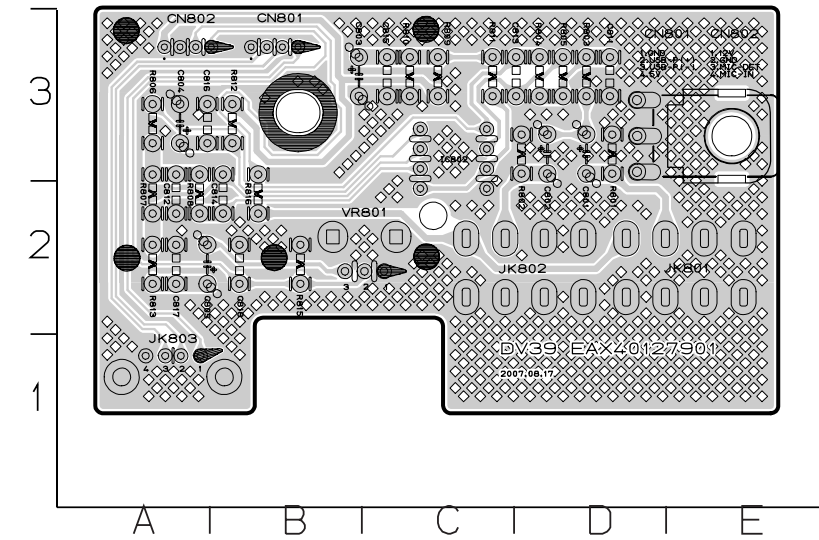

5. KEY P.C.BOARD

5-1. 4 TOOL (TOP VIEW)

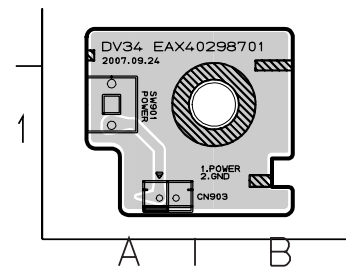

(BOTTOM VIEW)

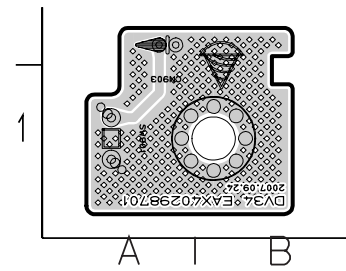

5-2. 5 TOOL (TOP VIEW)

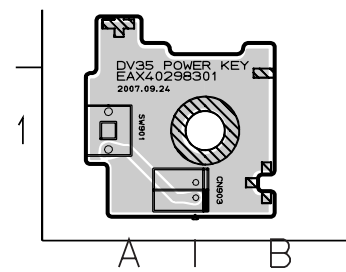

(BOTTOM VIEW)

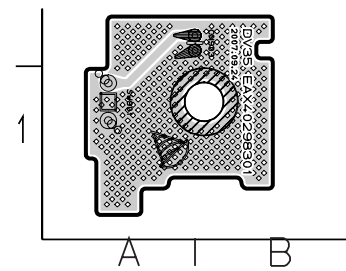

6. TIMER P.C.BOARD

6-1. 4 TOOL (TOP VIEW)

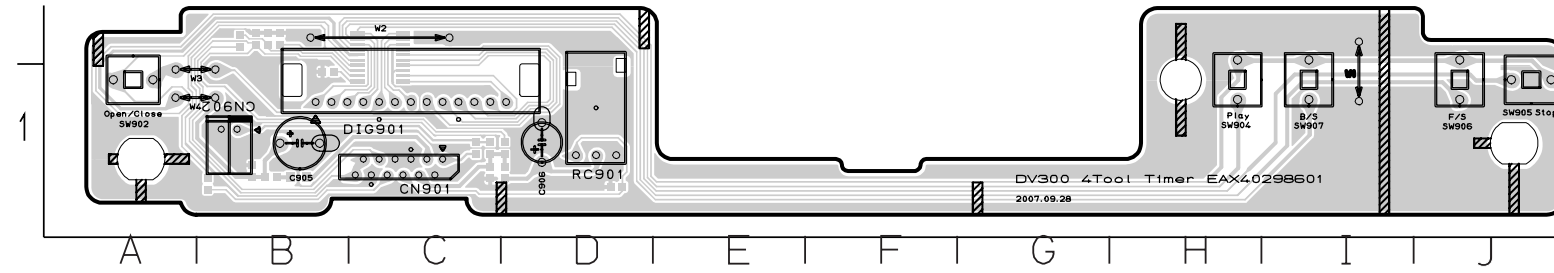

(BOTTOM VIEW)

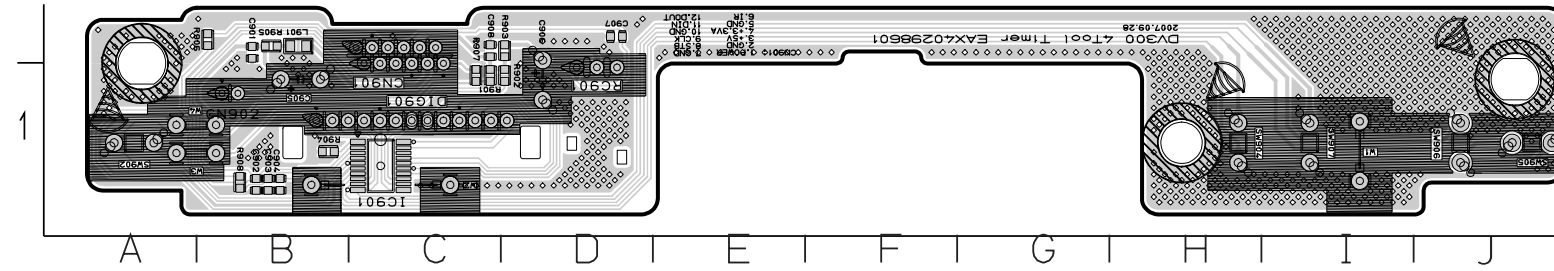

6-2. 5 TOOL (TOP VIEW)

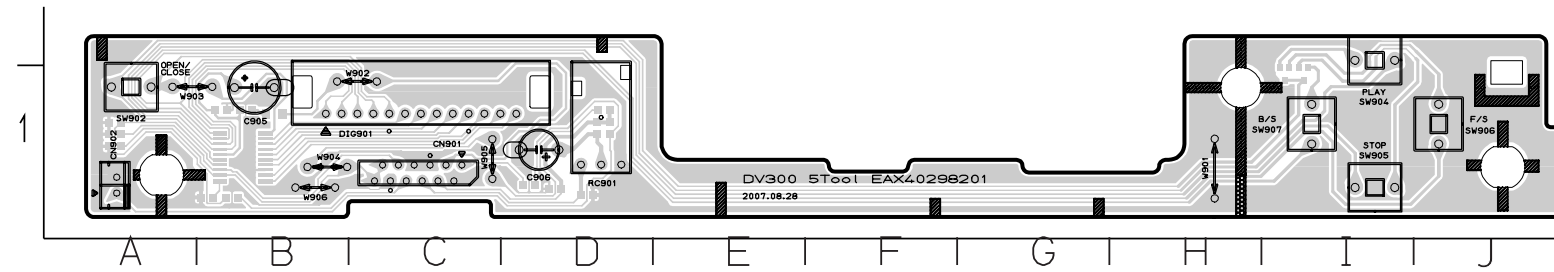

(BOTTOM VIEW)

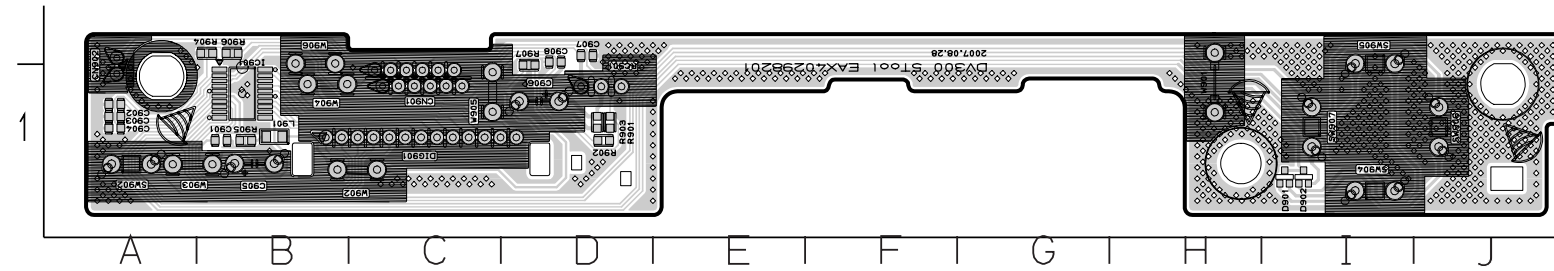

**5-3. 8 TOOL
(TOP VIEW)**

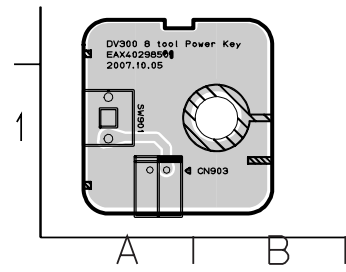

(BOTTOM VIEW)

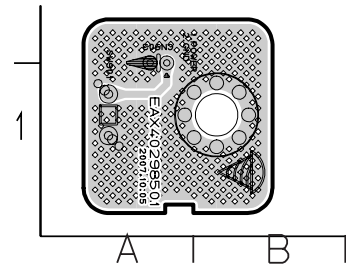

**6-3. 8 TOOL
(TOP VIEW)**

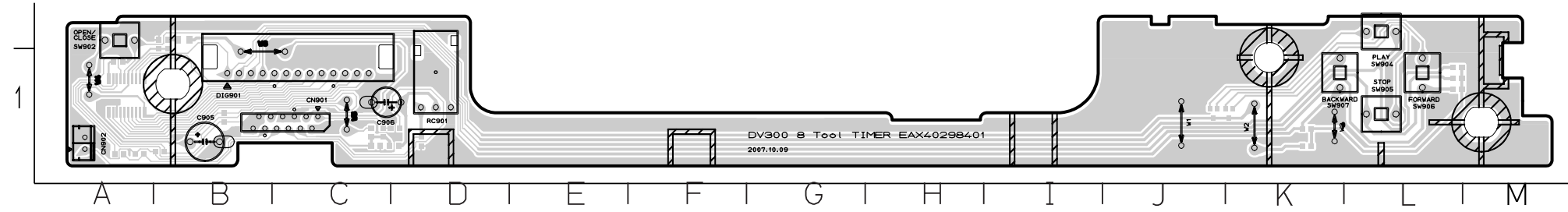

(BOTTOM VIEW)



**5-4. 9 TOOL
(TOP VIEW)**

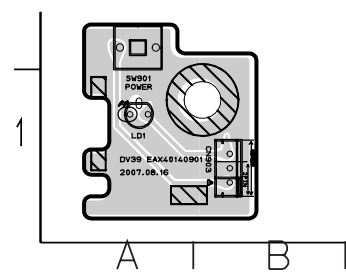

(BOTTOM VIEW)

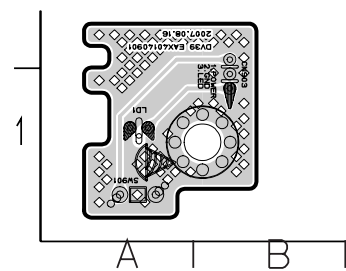

**6-4. 9 TOOL
(TOP VIEW)**



(BOTTOM VIEW)

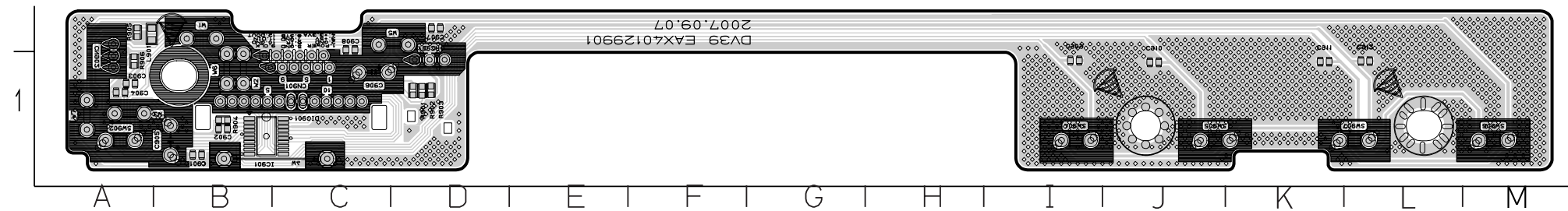

SECTION 4

MECHANISM (DP-12V)

CONTENTS

DECK MECHANISM PARTS LOCATIONS

- Top View.....4-2
- Top View(without Tray Disc)4-2
- Bottom View4-2

DECK MECHANISM DISASSEMBLY

- 1. Main Base4-3**
 - 1-1. Clamp Assembly Disc4-3
 - 1-1-1. Plate Clamp4-3
 - 1-1-2. Magnet Clamp4-3
 - 1-1-3. Clamp Upper4-3
- 2. Tray Disc4-3**
- 3. Base Assembly Sled4-4**
 - 3-1. Gear Feed.....4-4
 - 3-2. Gear Middle4-4
 - 3-3. Gear Rack.....4-4
- 4. Rubber Rear.....4-4**
- 5. Frame Assembly Up/Down.....4-5**
- 6. Belt Loading4-5**
- 7. Gear Pulley4-5**
- 8. Gear Loading4-5**
- 9. Guide Up/Down4-5**
- 10. PWB Assembly Loading.....4-5**
- 11. Base Main.....4-5**

EXPLODED VIEW

- 1. Deck Mechanism Exploded View4-7**

DECK MECHANISM PARTS LOCATION

• TOP VIEW (WITHOUT TRAY)

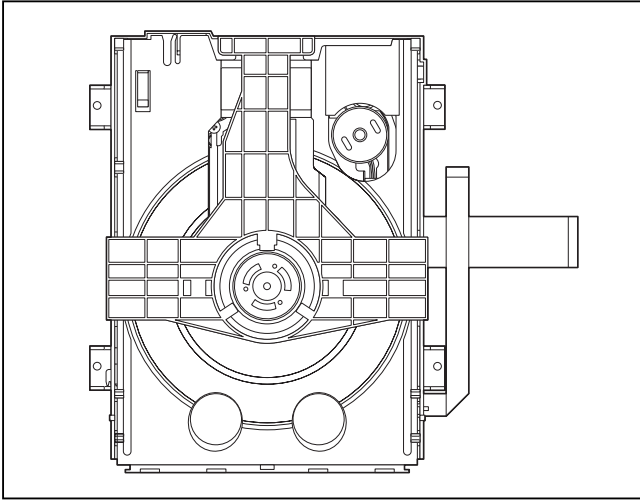

• TOP VIEW (WITH TRAY)

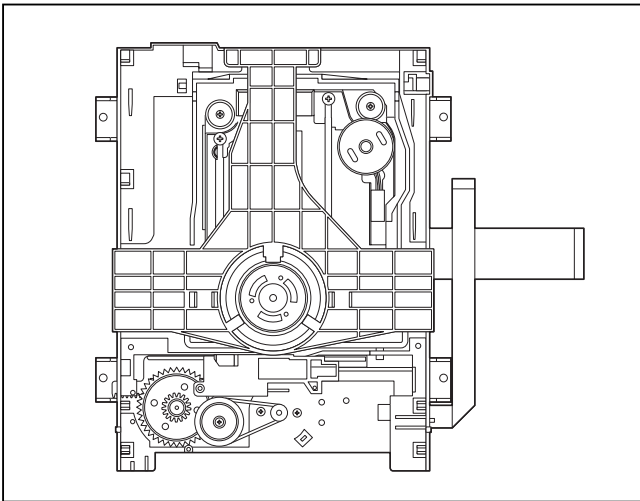

• BOTTOM VIEW

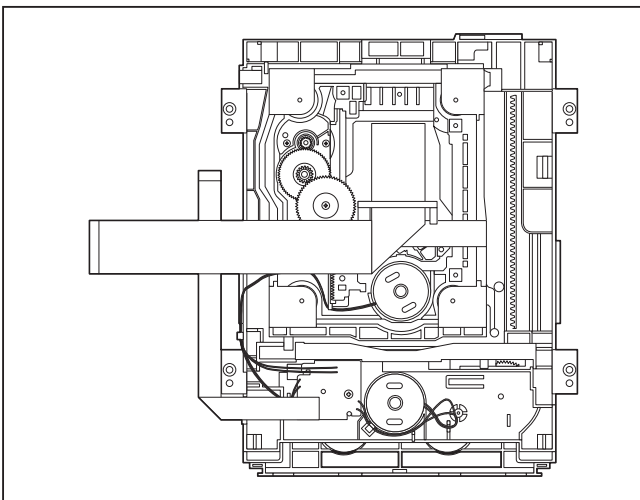

Procedure Starting No.	Parts	Fixing Type	Disassembly	Figure
1	Main Base			4-1
1	2 Clamp Assembly Disc			4-1
1, 2	3 Plate Clamp			4-1
1, 2, 3	4 Magnet Clamp			4-1
1, 2, 3, 4	5 Clamp Upper			4-1
1	6 Tray Disc			4-2
1, 6	7 Base Assembly Sled			4-3
1, 2, 6	8 Gear Feed	4 Screws, 1 Connector 1 Locking Tabs		4-3
1, 2, 6, 8	9 Gear Middle			
1, 2, 6, 8, 9	10 Gear Rack	1 Screw		4-3
1, 2, 7	11 Rubber Rear			4-3
1, 2, 7	12 Frame Assembly Up/Down	1 Screw	Bottom	4-4
1, 2	13 Belt Loading	1 Locking Tab		4-4
1, 2, 13	14 Gear Pulley			4-4
1, 2, 13, 14	15 Gear Loading	1 Locking Tab		4-4
1, 2, 7, 12, 13, 14	16 Guide Up/Down			4-4
1, 2, 13	17 PWB Assembly Loading	1 Locking Tab 1 Hook 2 Screw	Bottom	4-4
1, 2, 7, 12, 13, 14, 15, 16, 17	18 Base Main	2 Locking Tabs		4-4

Note

When reassembling, perform the procedure in reverse order.

The "Bottom" on Disassembly column of above Table indicates the part should be disassembled at the Bottom side.

DECK MECHANISM DISASSEMBLY

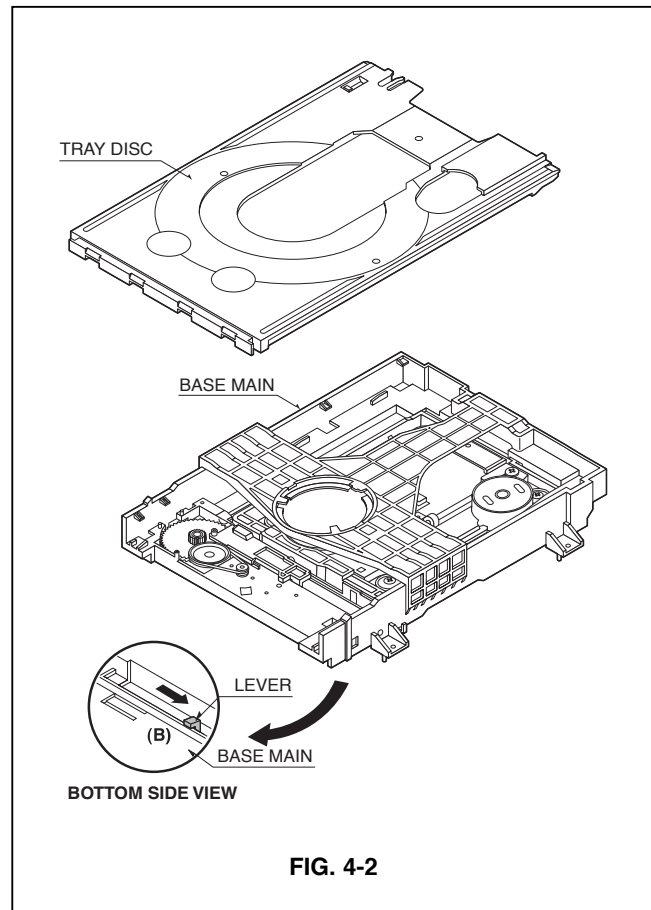
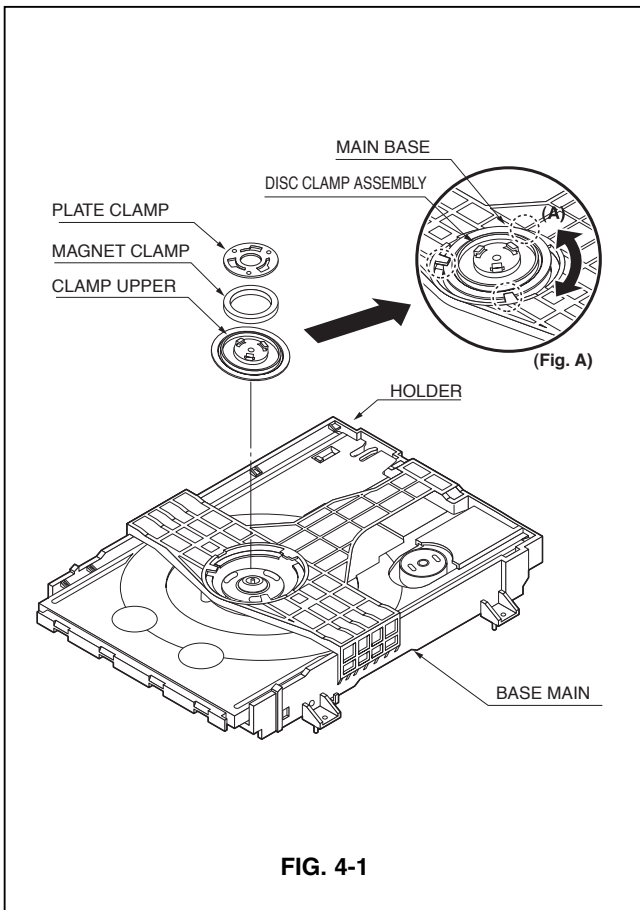

1. MAIN BASE (FIG. 4-1)

1-1. Clamp Assembly Disc

- 1) Place the Clamp Assembly Disc as Fig. (A)
- 2) Lift up the Clamp Assembly Disc in direction of arrow(A).
- 3) Separate the Clamp Assembly Disc from the Holder Clamp.

1-1-1. Plate Clamp

- 1) Turn the Plate Clamp to counterclockwise direction and then lift up the Plate Clamp.

1-1-2. Magnet Clamp

1-1-3. Clamp Upper

2. TRAY DISC (FIG. 4-2)

- 1) Insert and push a Driver in the emergency eject hole(A) at the right side, or put the Driver on the Lever(B) of the Gear Emergency and pull the Lever(B) in direction of arrow so that the Tray Disc is ejected about 15~20mm.
- 2) Pull the Tray Disc until it is separated from the Base Main completely.

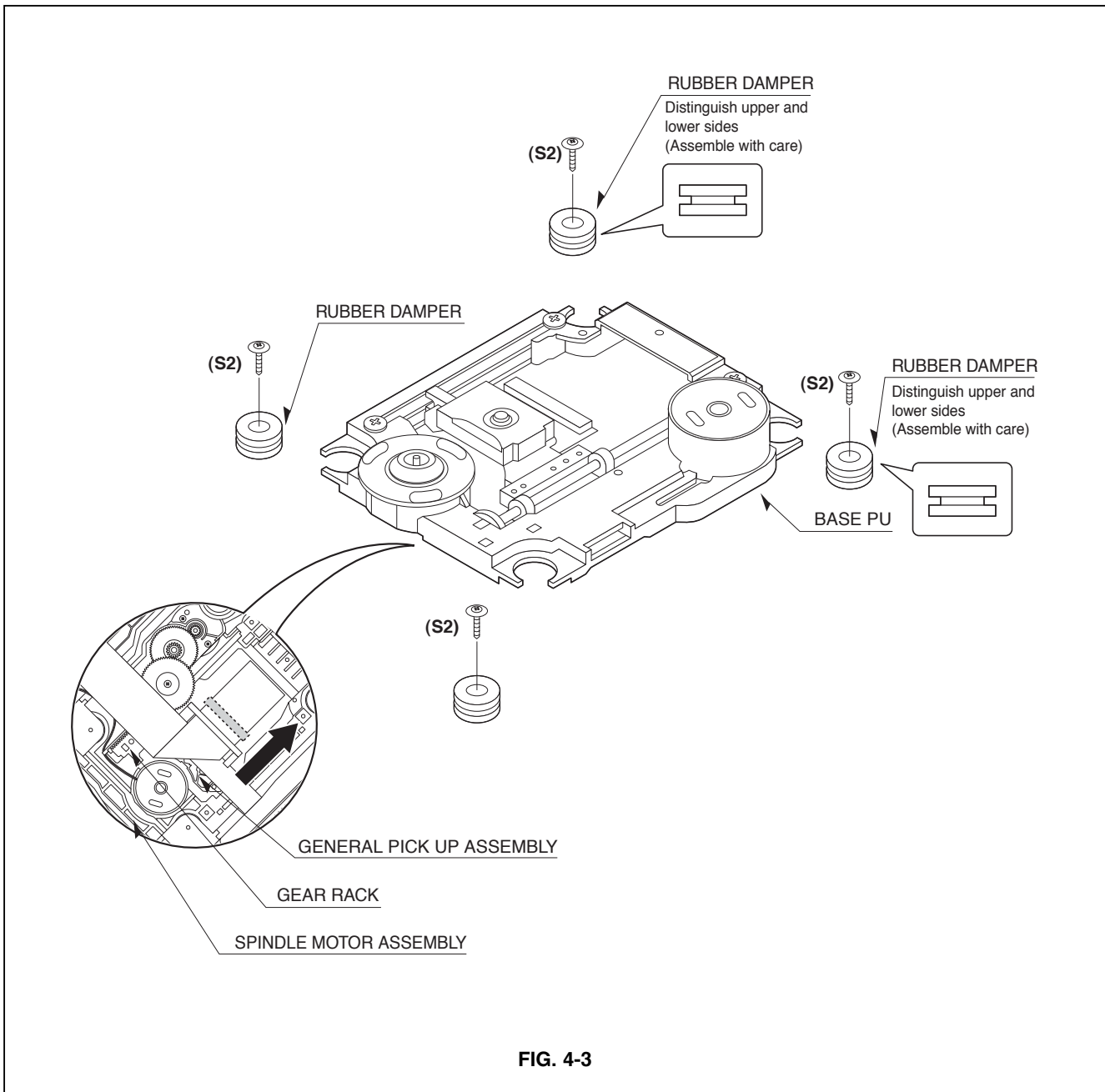

FIG. 4-3

3. BASE ASSEMBLY SLED (FIG. 4-3)

- 1) Release 4 Screw (S2).
- 2) Disconnect the FFC Connector (C1)

- 3-1. Gear Feed
- 3-2. Gear Middle

3-3. Gear Rack

- 1) Release the Scerw (S3)

4. RUBBER REAR (FIG. 4-3)

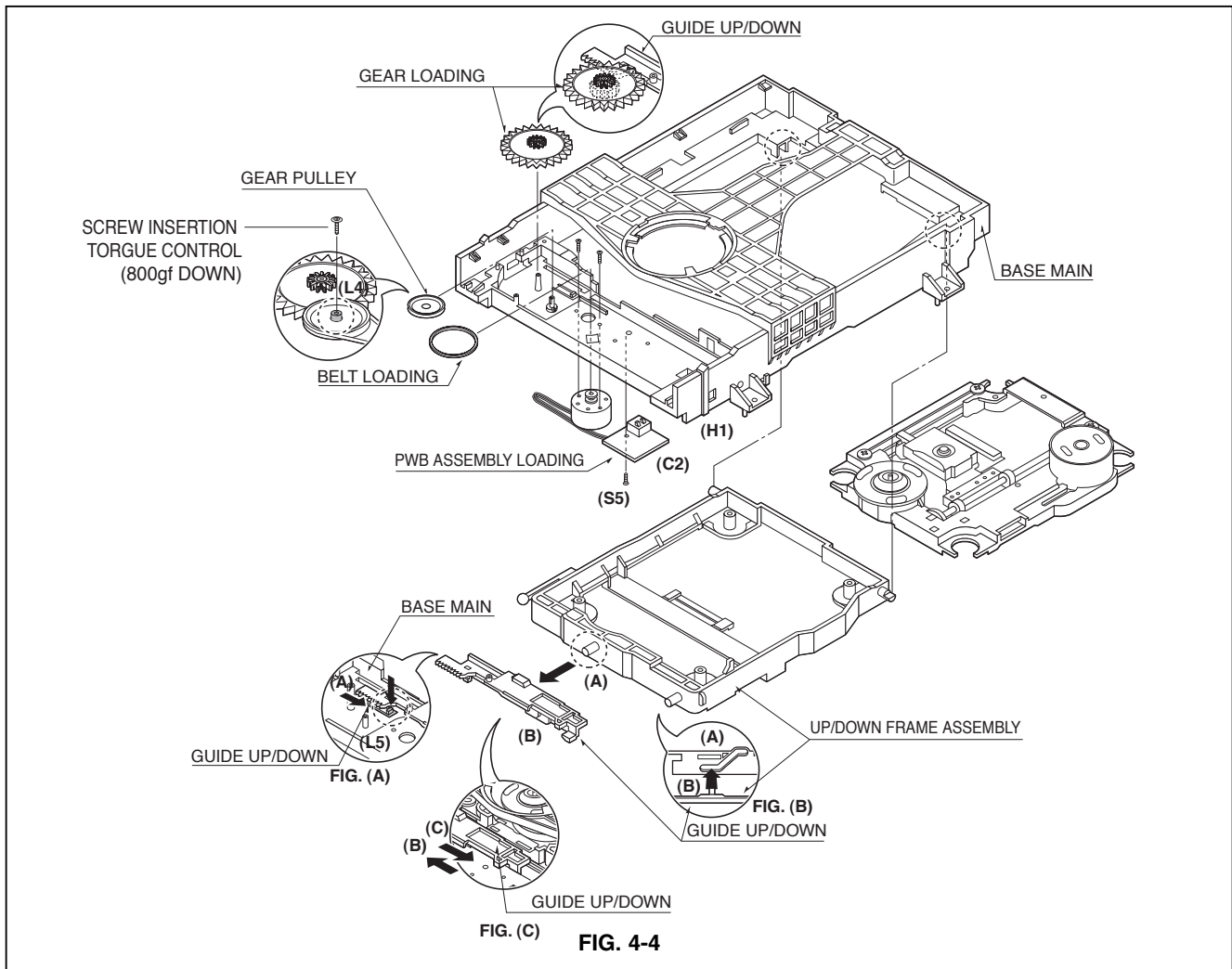

5. FRAME ASSEMBLY UP/DOWN (FIG. 4-4)

Note

Put the Base Main face down (Bottom Side)

- 1) Release the screw (S4)
- 2) Unlock the Locking Tab (L3) in direction of arrow and then lift up the Frame Assembly Up/Down to separate it from the Base Main.

Note

- When reassembling move the Guide Up/Down in direction of arrow (C) until it is positioned as Fig.(C).
- When reassembling insert (A) portion of the Frame Assembly Up/Down in the (B) portion of the Guide Up/Down as Fig.(B)

6. BELT LOADING (FIG. 4-4)

Note

Put the Base Main on original position (Top Side)

7. GEAR PULLEY (FIG. 4-4)

- 1) Unlock the Locking Tab (L4) in direction of arrow (B) and then separate the Gear Pulley from the Base Main

8. GEAR LOADING (FIG. 4-4)

9. GUIDE UP/DOWN (FIG. 4-4)

- 1) Move the Guide Up/Down in direction of arrow (A) as Fig.(A)
- 2) Push the Locking Tab (L5) down and then lift up the Guide Up/Down to separate it from the Base Main.

Note

When reassembling place the Guide Up/Down as Fig.(C) and move it in direction arrow (B) until it is locked by the Locking Tab (L5). And confirm the Guide Up/Down as Fig.(A)

10. PWB ASSEMBLY LOADING (FIG. 4-4)

Note

Put the Base Main face down (Bottom Side)

- 1) Release 1 Screws (S5)
- 2) Unlock the Loading Motor (C2) from the Hook (H1) on the Base Main.
- 3) Unlock 2 Locking Tabs (L6) and separate the PWB Assembly Loading from the Base Main.

11. BASE MAIN (FIG. 4-4)

MEMO

A series of horizontal dotted lines for writing.

EXPLODED VIEW

1. DECK MECHANISM EXPLODED VIEW DP-12V

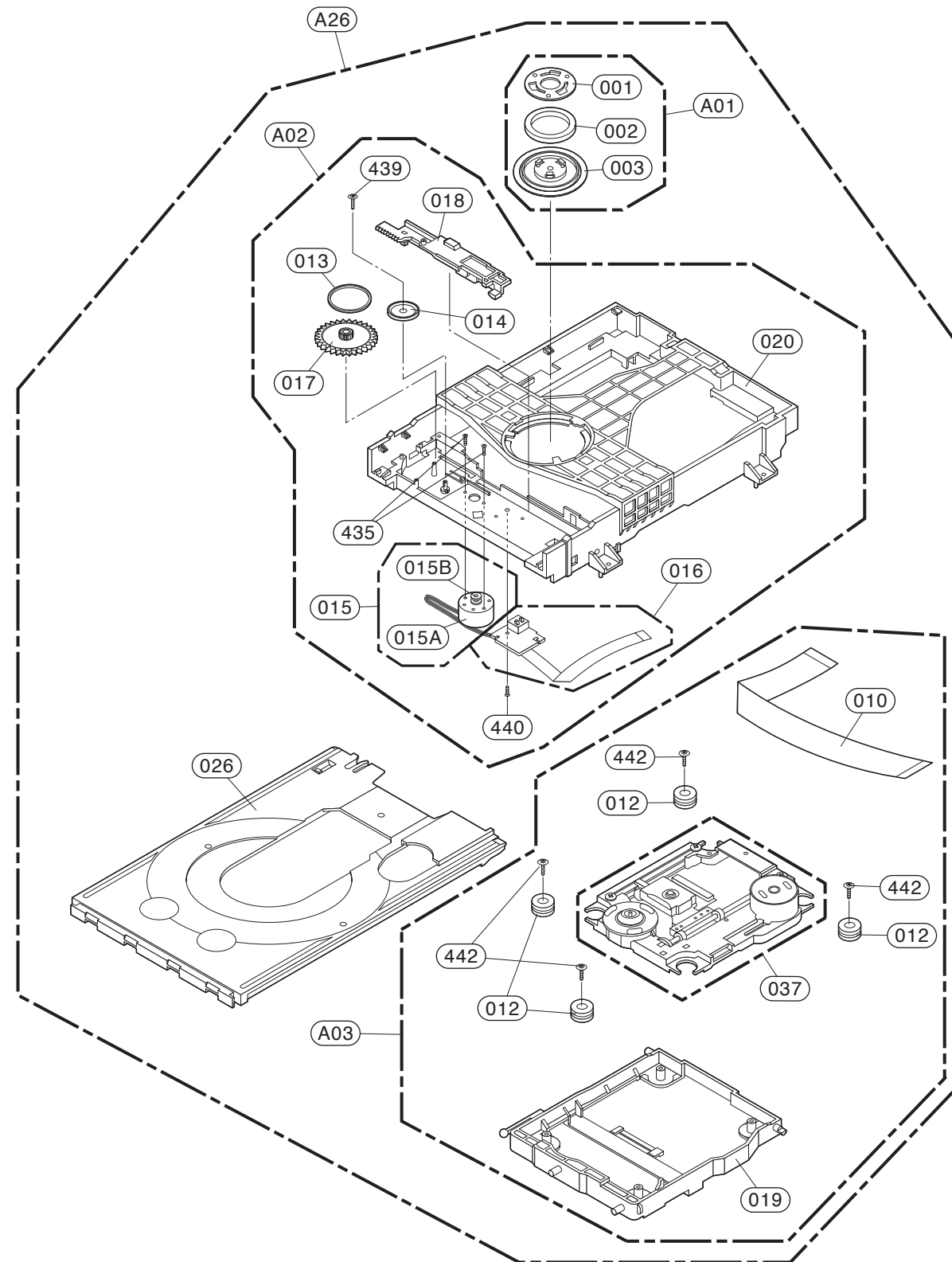

MEMO

Horizontal dotted lines for writing.

MEMO

Horizontal dotted lines for writing.