



SERVICE MANUAL

MODELS : DVD6054/DVD6184(DV7511E6S/DV7811E6S)



DVD VIDEO PLAYER SERVICE MANUAL

**MODELS : DVD6054/DVD6184
(DV7511E6S/DV7811E6S)**

CAUTION

BEFORE SERVICING THE UNIT, READ THE "SAFETY PRECAUTIONS"
IN THIS MANUAL.

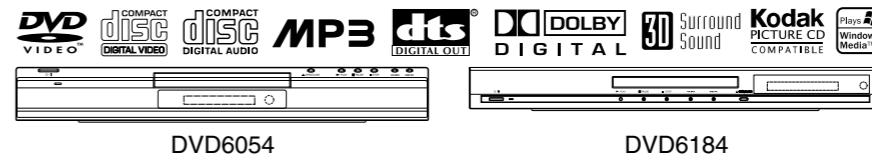

P/NO : 3829RHP017A

SEPTEMBER, 2003
Printed in Korea

LG Electronics Inc.

SECTION 1

SUMMARY

CONTENTS

PRODUCT SAFETY SERVICING GUIDELINES FOR VIDEO PRODUCTS	1-2
SERVICING PRECAUTIONS	1-3
• General Servicing Precautions	
• Insulation Checking Prodedure	
• Electrostatically Sensitive Devices	
SPECIFICATIONS	1-4

PRODUCT SAFETY SERVICING GUIDELINES FOR VIDEO PRODUCTS

IMPORTANT SAFETY NOTICE

This manual was prepared for use only by properly trained audio-video service technicians.

When servicing this product, under no circumstances should the original design be modified or altered without permission from LG Electronics Corporation. All components should be replaced only with types identical to those in the original circuit and their physical location, wiring and lead dress must conform to original layout upon completion of repairs.

Special components are also used to prevent x-radiation, shock and fire hazard. These components are indicated by the letter "X" included in their component designators and are required to maintain safe performance. No deviations are allowed without prior approval by LG Electronics Corporation.

Circuit diagrams may occasionally differ from the actual circuit used. This way, implementation of the latest safety and performance improvement changes into the set is not delayed until the new service literature is printed.

CAUTION: Do not attempt to modify this product in any way. Never perform customized installations without manufacturer's approval. Unauthorized modifications will not only void the warranty, but may lead to property damage or user injury.

Service work should be performed only after you are thoroughly familiar with these safety checks and servicing guidelines.

GRAPHIC SYMBOLS



The exclamation point within an equilateral triangle is intended to alert the service personnel to important safety information in the service literature.



The lightning flash with arrowhead symbol within an equilateral triangle is intended to alert the service personnel to the presence of noninsulated "dangerous voltage" that may be of sufficient magnitude to constitute a risk of electric shock.



The pictorial representation of a fuse and its rating within an equilateral triangle is intended to convey to the service personnel the following fuse replacement caution notice:

CAUTION: FOR CONTINUED PROTECTION AGAINST RISK OF FIRE, REPLACE ALL FUSES WITH THE SAME TYPE AND RATING AS MARKED NEAR EACH FUSE.

SERVICE INFORMATION

While servicing, use an isolation transformer for protection from AC line shock. After the original service problem has been corrected, make a check of the following:

FIRE AND SHOCK HAZARD

1. Be sure that all components are positioned to avoid a possibility of adjacent component shorts. This is especially important on items transported to and from the repair shop.
2. Verify that all protective devices such as insulators, barriers, covers, shields, strain reliefs, power supply cords, and other hardware have been reinstalled per the original design. Be sure that the safety purpose of the polarized line plug has not been defeated.
3. Soldering must be inspected to discover possible cold solder joints, solder splashes, or sharp solder points. Be certain to remove all loose foreign particles.
4. Check for physical evidence of damage or deterioration to parts and components, for frayed leads or damaged insulation (including the AC cord), and replace if necessary.
5. No lead or component should touch a high current device or a resistor rated at 1 watt or more. Lead tension around protruding metal surfaces must be avoided.
6. After reassembly of the set, always perform an AC leakage test on all exposed metallic parts of the cabinet (the channel selector knobs, antenna terminals, handle and screws) to be sure that set is safe to operate without danger of electrical shock. **DO NOT USE A LINE ISOLATION TRANSFORMER DURING THIS TEST.** Use an AC voltmeter having 5000 ohms per volt or more sensitivity in the following manner: Connect a 1500 ohm, 10 watt resistor, paralleled by a .15 mfd 150V AC type capacitor between a known good earth ground water pipe, conduit, etc.) and the exposed metallic parts, one at a time. Measure the AC voltage across the combination of 1500 ohm resistor and .15 mfd capacitor. Reverse the AC plug by using a non-polarized adaptor and repeat AC voltage measurements for each exposed metallic part. Voltage measured must not exceed 0.75 volts RMS. This corresponds to 0.5 milliamp AC. Any value exceeding this limit constitutes a potential shock hazard and must be corrected immediately.

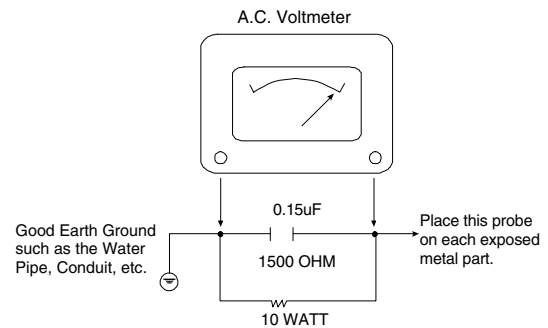

TIPS ON PROPER INSTALLATION

1. Never install any receiver in a closed-in recess, cubbyhole, or closely fitting shelf space over, or close to, a heat duct, or in the path of heated air flow.
2. Avoid conditions of high humidity such as: outdoor patio installations where dew is a factor, near steam radiators where steam leakage is a factor, etc.
3. Avoid placement where draperies may obstruct venting. The customer should also avoid the use of decorative scarves or other coverings that might obstruct ventilation.
4. Wall- and shelf-mounted installations using a commercial mounting kit must follow the factory-approved mounting instructions. A product mounted to a shelf or platform must retain its original feet (or the equivalent thickness in spacers) to provide adequate air flow across the bottom. Bolts or screws used for fasteners must not touch any parts or wiring. Perform leakage tests on customized installations.
5. Caution customers against mounting a product on a sloping shelf or in a tilted position, unless the receiver is properly secured.
6. A product on a roll-about cart should be stable in its mounting to the cart. Caution the customer on the hazards of trying to roll a cart with small casters across thresholds or deep pile carpets.
7. Caution customers against using extension cords. Explain that a forest of extensions, sprouting from a single outlet, can lead to disastrous consequences to home and family.

SERVICING PRECAUTIONS

CAUTION : Before servicing the DVD covered by this service data and its supplements and addends, read and follow the **SAFETY PRECAUTIONS**. **NOTE :** if unforeseen circumstances create conflict between the following servicing precautions and any of the safety precautions in this publication, always follow the safety precautions.

Remembers Safety First:

General Servicing Precautions

1. Always unplug the DVD AC power cord from the AC power source before:
 - (1) Removing or reinstalling any component, circuit board, module, or any other assembly.
 - (2) Disconnection or reconnecting any internal electrical plug or other electrical connection.
 - (3) Connecting a test substitute in parallel with an electrolytic capacitor.
Caution : A wrong part substitution or incorrect polarity installation of electrolytic capacitors may result in an explosion hazard.
2. Do not spray chemicals on or near this DVD or any of its assemblies.
3. Unless specified otherwise in this service data, clean electrical contacts by applying an appropriate contact cleaning solution to the contacts with a pipe cleaner, cotton-tipped swab, or comparable soft applicator. Unless specified otherwise in this service data, lubrication of contacts is not required.
4. Do not defeat any plug/socket B+ voltage interlocks with which instruments covered by this service manual might be equipped.
5. Do not apply AC power to this DVD and/or any of its electrical assemblies unless all solid-state device heat sinks are correctly installed.
6. Always connect test instrument ground lead to the appropriate ground before connection the test instrument positive lead. Always remove the test instrument ground lead last.

Insulation Checking Procedure

Disconnect the attachment plug from the AC outlet and turn the power on. Connect an insulation resistance meter(500V) to the blades of the attachment plug. The insulation resistance between each blade of the attachment plug and accessible conductive parts (Note 1) should be more than 1M-ohm.

Note 1 : Accessible Conductive Parts including Metal panels, Input terminals, Earphone jacks, etc.

Electrostatically Sensitive (ES) Devices

Some semiconductor (solid state) devices can be damaged easily by static electricity. Such components commonly are called Electrostatically Sensitive (ES) Devices. Examples of typical ES devices are integrated circuits and some field effect transistors and semiconductor chip components.

The following techniques should be used to help reduce the incidence of component damage caused by static electricity.

1. Immediately before handling any semiconductor component or semiconductor-equipped assembly, drain off any electrostatic charge on your body by touching a known earth ground. Alternatively, obtain and wear a commercially available discharging wrist strap device, which should be removed for potential shock reasons prior to applying power to the unit under test.
2. After removing an electrical assembly equipped with ES devices, place the assembly on a conductive surface such as aluminum foil, to prevent electrostatic charge buildup or exposure of the assembly.
3. Use only a grounded-tip soldering iron to solder or unsolder ES devices.
4. Use only an anti-static solder removal device. Some solder removal devices not classified a "anti-static" can generate electrical charges sufficient to damage ES devices.
5. Do not use freon-propelled chemicals. These can generate electrical charge sufficient to damage ES devices.
6. Do not remove a replacement ES device from its protective package until immediately before you are ready to install it. (Most replacement ES devices are packaged with leads electrically shorted together by conductive foam, aluminum foil, or comparable conductive material).
7. Immediately before removing the protective material from the leads of a replacement ES device, touch the protective material to the chassis or circuit assembly into which the device will be installed.

Caution : Be sure no power is applied to the chassis or circuit, and observe all other safety precautions.

8. Minimize bodily motions when handling unpackaged replacement ES devices. (Normally harmless motion such as the brushing together of your clothes fabric or the lifting of your foot from a carpeted floor can generate static electricity sufficient to damage an ES device.)

SPECIFICATIONS

• GENERAL

Power requirements	AC 120V, 60Hz
Power consumption	14W
Dimensions(approx.)	430 x 43 x 242mm (W/h/d)
Weight(approx.)	2.34kg
Operating temperature	5°C to 35°C (41°F to 95°F)
Operating humidity	5% to 90%

• SYSTEM

Laser	Semiconductor laser, wavelength 650nm
Signal system	PAL/NTSC
Frequency response	DVD (PCM 96kHz): 8Hz to 44kHz DVD (PCM 48kHz): 2Hz to 22kHz CD: 8Hz to 20kHz
Signal-to-noise ratio	More than 100dB (ANALOG OUT connectors only)
Harmonic distortion	Less than 0.008%
Dynamic range	More than 100dB(DVD) More than 95dB(CD)

• OUTPUTS

VIDEO OUT	1 V (p-p) 75 Ω , sync negative, RCA jack x 1 (TO TV)
Audio output (digital audio)	0.5 V (p-p), 75 Ω , RCA jack x 1
Audio output (analog audio)	2.0 Vrms (1 kHz, 0 dB), 600 Ω , RCA jack (L, R) x 1 (TO TV)

SECTION 2
CABINET & MAIN CHASSIS

CONTENTS

1. EXPLODED VIEWS2-2
 1. Cabinet and Main Frame Section2-2
 2. Packing Accessory Section2-5

EXPLODED VIEWS

1. Cabinet and Main Frame Section

★ OPTIONAL PART

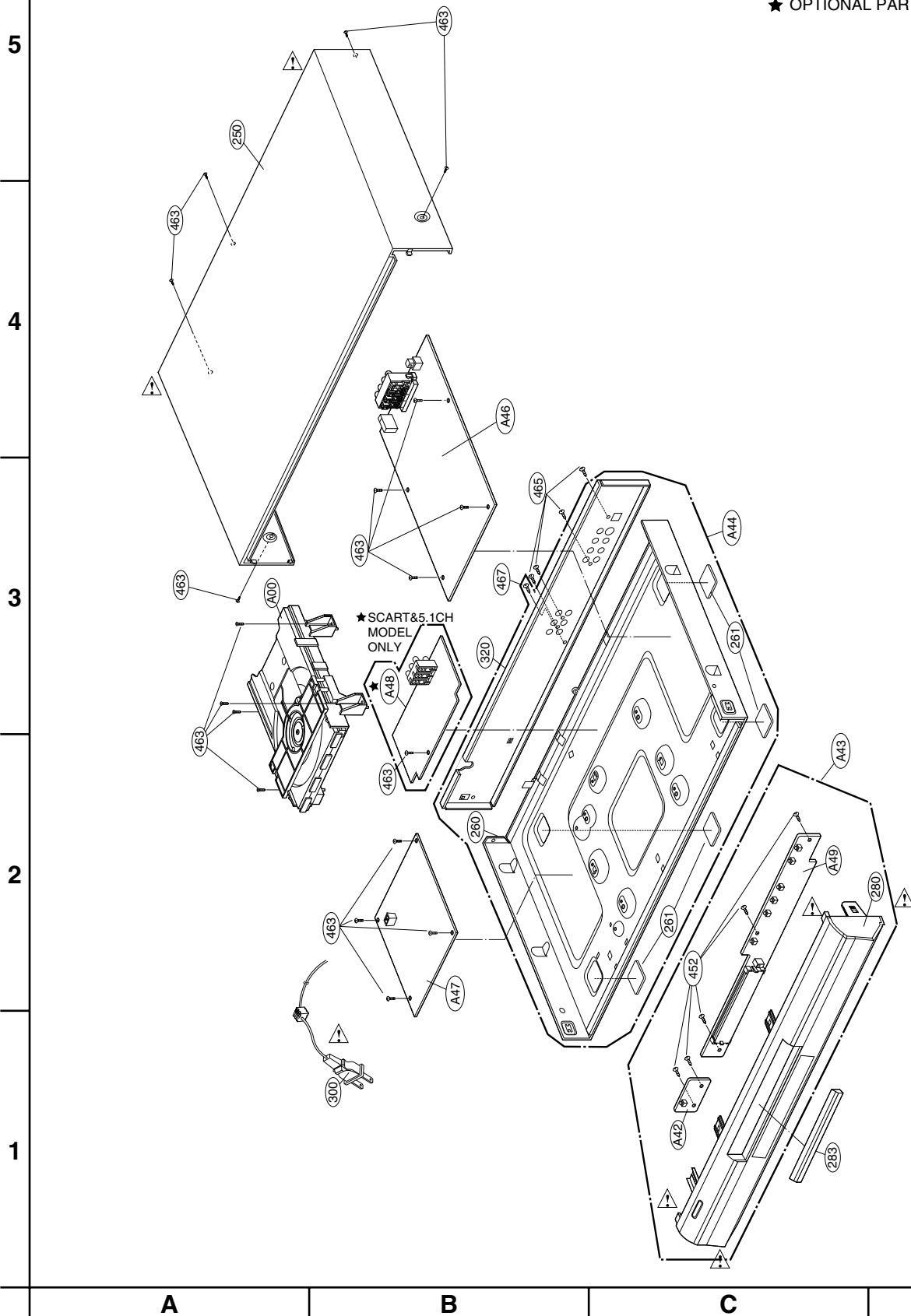

• Cabinet and Main Frame Section Part List

MODELS:(A)DV7511E6S(DVD6054) (B)DV7811E6S(DVD6184)

S	AL	LOCA.NO	PART NO(LG)	A	B	DESCRIPTION	SPECIFICATION	REMARKS
ASSEMBLY PARTS SECTION								
		A42	6871R-5725A	O		PWB(PCB) ASSEMBLY,TOTAL	DV7000S 5TOOL KEY SH	
		A42	6871R-5728A		O	PWB(PCB) ASSEMBLY,TOTAL	DV7000S 8TOOL KEY SH	
		A43	3501RF3007C		O	BOARD ASSEMBLY	DVD DV7811E4M HA3GLL	
		A43	3501RF6694F	O		BOARD ASSEMBLY	DVD DV7511E6L HA8PLL	
		A44	3141R-D003F	O		CHASSIS ASSEMBLY	DV7510E LSI,MTK 55MM	NSP
		A44	3141R-D004F		O	CHASSIS ASSEMBLY	DV7810E MTK 43MM	
		A46	6885R-1015D	O		SUB PWB(PCB) ASSEMBLY	DV7511E6S HA8PLL	
		A46	6885R-1015J		O	SUB PWB(PCB) ASSEMBLY	DV7811E6S HA8PLL	
		A47	6871R-7604C	O		PWB(PCB) ASSEMBLY,TOTAL	DV7000S SMPS SH 220V(CE)	
		A47	6871R-7604D		O	PWB(PCB) ASSEMBLY,TOTAL	DV7000S LSI SMPS SH 220V (CE)	
		A48	6871R-7601C	O	O	PWB(PCB) ASSEMBLY,TOTAL	DV7000S MTK SH SCART	
		A49	6871R-5715A	O		PWB(PCB) ASSEMBLY,TOTAL	DV7000S 5TOOL TIMER SH	
		A49	6871R-5718A		O	PWB(PCB) ASSEMBLY,TOTAL	DV7000S 8TOOL TIMER SH	
PARTS SECTION								
		250	3110R-D001A	O		CASE	DV7000 PRESS 430-55(A288G)	
		250	3110R-D004A		O	CASE	DV7000 PRESS 43MM A288G	
		260	3140R-D002A	O	O	CHASSIS	DV7000 PRESS MAIN	NSP
		261	5040R-0069D	O	O	RUBBER	FOOT(SILICONE SPONGE DS-08 T=	
		280	3721R-F306F	O		PANEL ASSEMBLY,FRONT NORMAL PA	DV7511E6L HA8PLL	NSP
		280	3721R-F318C		O	PANEL ASSEMBLY,FRONT NORMAL PA	DV7811E4M HA3GLL	NSP
		283	3581R-T068B	O		DOOR ASSEMBLY	TRAY DV7500 (CHINA)	
		283	3581R-T069A	O		DOOR ASSEMBLY	TRAY DV7800 (SPRAY)	
	△	300	6410RCHX03A	O	O	POWER CORD	CE-503/JL201B H03VVH2-F 2X0.75	
		320	3720R-D072F	O		PANEL,VIDEO	DVD DV7510E PRESS LSI,MTK 55MM	
		320	3720R-D074F		O	PANEL,VIDEO	DVD DV7810E PRESS MTK 43MM	
SCREW								
		452	353-051A	O		SCREW	SPECIAL	
		452	353-051A		O	SCREW	SPECIAL	
		463	353-051G	O	O	SCREW,DRAWING	+ 2 D3.0 L8.0 MSWR3/FN TB ROUN	
		465	353-046K	O	O	SCREW	SPECIAL (3X10 B.K)	
		467	353-046N	O	O	SCREW,DRAWING	SPECIAL(3X8 BK.)	

3. Packing Accessory Section

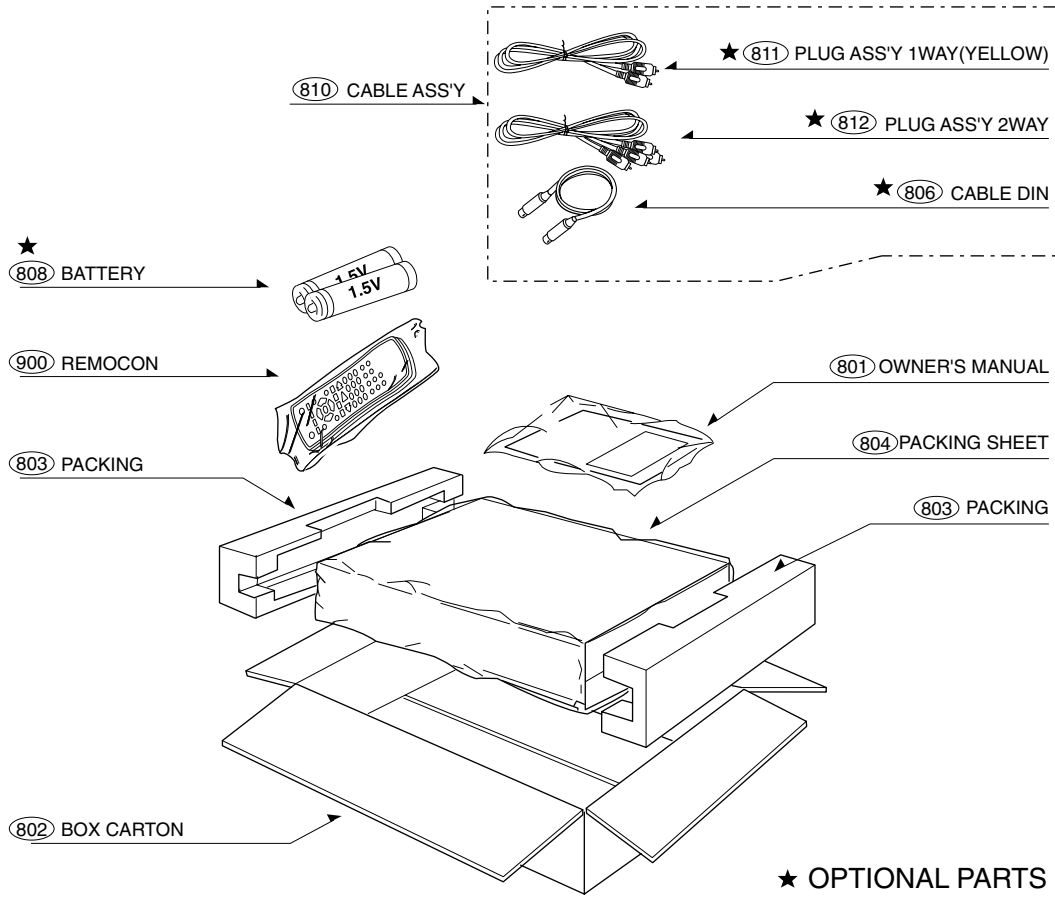

• Packing Accessory Section Part List

MODELS:(A)DV7511E6S(DVD6054) (B)DV7811E6S(DVD6184)

S	AL	LOCA.NO	PART NO(LG)	A	B	DESCRIPTION	SPECIFICATION	REMARKS
		801	3835RS0063W	O		INSTRUCTION ASSEMBLY	DVD DV7511E6S HA8PLL	
		801	3835RS0064A		O	INSTRUCTION ASSEMBLY	DVD DV7811E6S HA8PLL	
		802	3890R-H803L	O	O	BOX	DV7511E6M HA8PLL SWW3-A 0.870	
		803	3920R-E066A	O	O	PACKING,CASING	DV7000 0.02 68 EPS 10 1165 238	
		804	292-053B	O	O	BAG	SOFT(MIDI)	NSP
		808	841-0021	O	O	BATTERY,MN	ER03X HI WATT 1.5V .MA/H AAA	
		810	6851RP0003N	O	O	CABLE ASSY,RF	DVD CABLE ASSY,RCA USING AREA	
		811	6611R1G001A	O	O	PLUG ASSY	1WAY YELLOW GLOBAL	
		812	6611R2G001A	O	O	PLUG ASSY	2WAY RED/WHITE GLOBAL	
		900	6711R1P063A	O	O	REMOTE CONTROLLER ASSEMBLY	N6 UNIFIED DV7520E LG W/O DISC	

SECTION 3

ELECTRICAL

CONTENTS

DVD PART

ELECTRICAL TROUBLESHOOTING GUIDE & WAVEFORMS	3-2
1. System Clock X501 (27Mhz)	3-2
2. Initializing between MPEG and SDRAM	3-2
3. Initializing between MPEG and Flash	3-3
4. Reference Voltage 1.....	3-3
5. Reference Voltage 2.....	3-4
6. Checking the initial step of M/D Ass'y	3-4
7. Checking the Video Signal	3-5
8. Checking the first step of servo (1)	3-5
9. Checking the second step of servo (2)	3-6
10. Checking the output of Audio signal.....	3-6
11. Checking the reset port.....	3-7
12. Checking the focus & tracking servo	3-7
13. Checking the track jump.....	3-8
14. The status of CD_LD and DVD_LD in the PLAY MODE	3-8
15. The status Focus and spindle motor.....	3-9
16. DATA STREAM	3-9
17. Input Clock to IC202	3-10
18. Tray Open and Close.....	3-10
19. Focus Drive signal(FACT)	3-11
20. Signals for Front micom	3-11
21. FACT and FE for DVD9 (Dual disc)	3-12
22. System clock of MPEG IC.....	3-12
BLOCK DIAGRAMS	3-13
1. DVD Overall Block Diagram.....	3-13
2. SERVO Block Diagram	3-14
3. MPEG Block Diagram	3-15
4. AUDIO Block Diagram	3-16
CIRCUIT DIAGRAMS	3-17
1. POWER(SMPS) CIRCUIT DIAGRAM.....	3-17
2. RF SERVO CIRCUIT DIAGRAM.....	3-19
3. SYSTEM CIRCUIT DIAGRAM	3-21
4. AUDIO & JACK CIRCUIT DIAGRAM.....	3-23
5. TIMER/5.1CH CIRCUIT DIAGRAM.....	3-25
• CIRCUIT VOLTAGE CHART	3-27
PRINTED CIRCUIT DIAGRAMS	3-31
1. MAIN P.C.BOARD	3-31
2. KEY P.C.BOARD.....	3-33
3. TIMER P.C.BOARD.....	3-33
4. SCART P.C.BOARD.....	3-35
4. POWER(SMPS P.C.BOARD	3-36

DVD PART

ELECTRICAL TROUBLESHOOTING GUIDE & WAVEFORMS

1. System Clock X501 (27Mhz)

NORMAL

- 1) MPEG IC start oscilating after being installed VCC

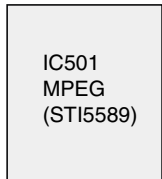

X501

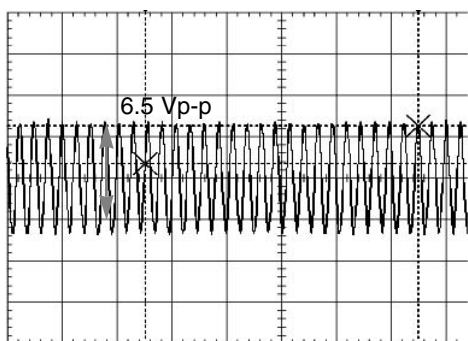

X501 : 27 Mhz

ABNORMAL

- 1) Logo Picture doesn't appear
- 2) Initial step fail
 - * Initial step : power cord in -> green LED -> red LED -> power key input -> Logo picture

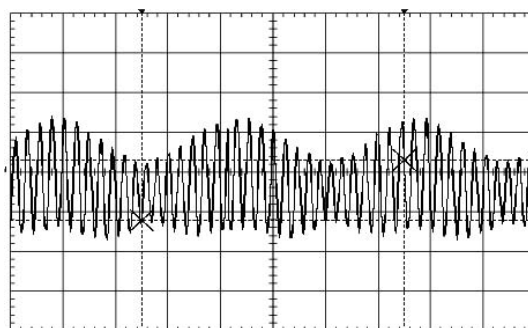

X501 : there is distortion

2. Initializing between MPEG and SDRAM

- 1) MPEG IC start oscilating(27Mhz)after being installed VCC
- 2) MPEG IC and DSP IC get the /M - RESET signal from front μ -com and they are initialized.
- 3) And then, MPEG IC generate SMI_CLK and send to SDRAM

- 4) MPEG IC and SDRAM are synchronized by SMI_CLK, they communicate between.

If oscilation(27Mhz) don't appear, check The X-TAL and VCC and replace MPEG IC.

If SMI_CLK don't appear, first cut the SMI_CLK line (remove L507) and recheck.
Don't appear -> check MPEG IC or replace
Appear -> check the SDRAM or replace

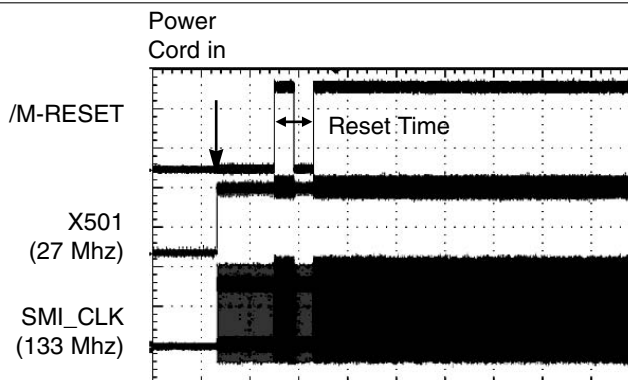
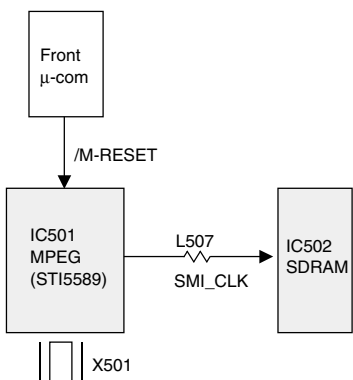

3. Initializing between MPEG and Flash

- 1) MPEG IC start oscilating(27Mhz) after being installed VCC
- 2) MPEG IC is initialized by /M - RESE T
- 3) MPEG IC send the WE(read/write) signal before communicating with FLASH ROM

WE signal should be confirmed by Flash or the next step will not continue.

As that result, the initial step(power cord in -> green LED -> red LED -> standby) will fail.

If WE signal doesn't appear, check the VCC and replace the Flash ROM...

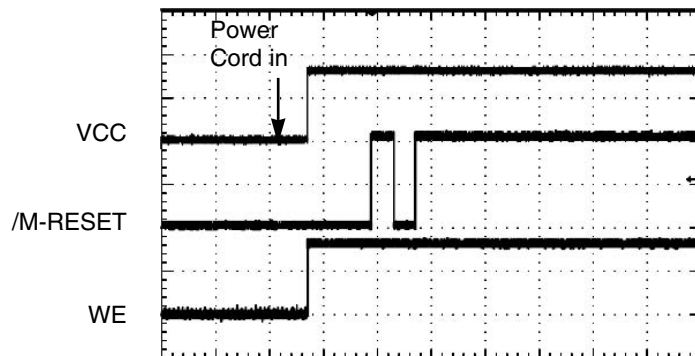
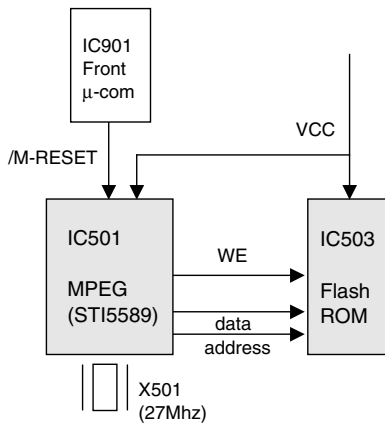

4. Reference Voltage 1

- 1) There is one kinds of reference voltage on DSP IC
- 2) These are outputed from DSP IC and 2.1V is used as reference of Pick - up

IC and replace...

- 3) The reference voltage of DSP is 1.65V for inside of IC L6316, but we can chek the voltage only by TP.

If these reference voltage don't appear, All kinds of servo control will fail.

TP211 is for tracking error and TP212 is for focusing error.

So, should be checked first of all Check the DSP

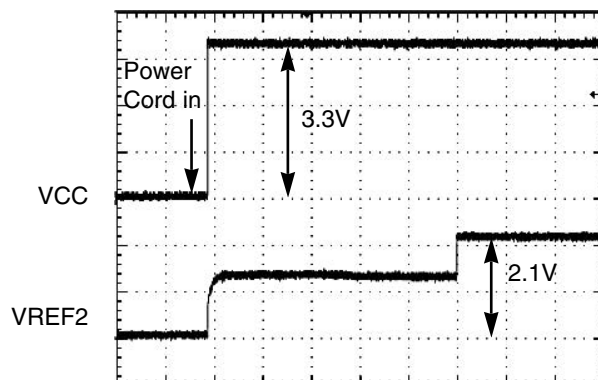
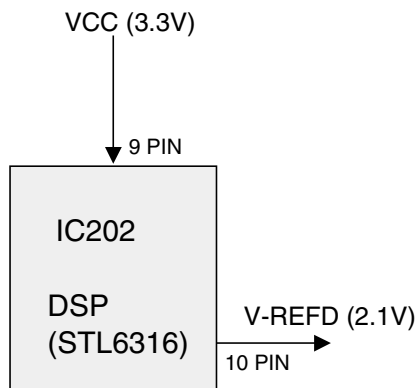

5. Reference Voltage 2

We can see how the reference voltage, mentioned previous page, will work on servo control..

- 1) The DC level of RF signal from P/up is 2.1V
- 2) The DC level of TE and FE is 1.65V
- 3) Correct DC level of these signal make servo work normally.

Even though, the reference voltage come out correctly from DSP,

If A/B/C/D are not biased by 2.1V, and checking the P/up is needed.

If the DC level of TE is not 1.65V, check DSP and replace it...

In case of FE, procedure is same

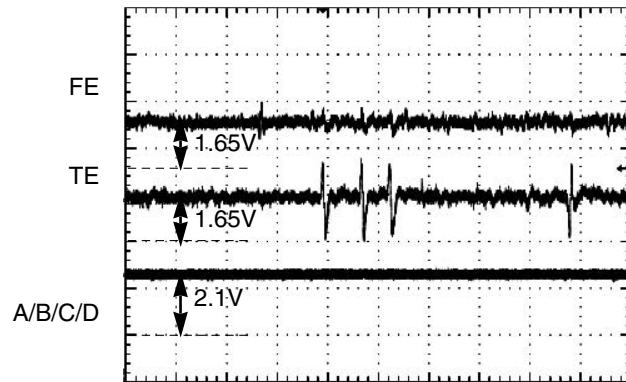
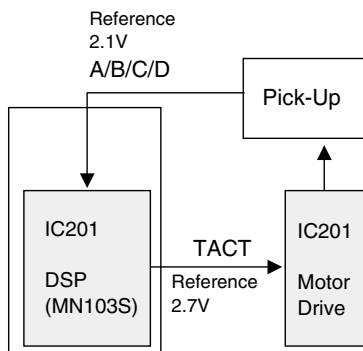

6. Checking the initial step of M/D Ass'y

Let's look over the initial action of M/D...

- 1) When the tray is closed, CLOSE-SW should be changed from 5V to 0V and DSP need to detect this change
- 2) Feeding Motor move the P/up to inner area until the LIMIT SW is detected
- 3) After DSP detect the LIMIT SW, DVD laser is turned on and go to the next step

4) if there is a DISC on the tray, the RF will be detected by the DVD laser and go to next step..

Check the CLOSE-SW and LIMIT-SW

if anything of the both is not detected, the next step won't go on. This means that even though there is a DISC on the tray the DISC will not rotate.

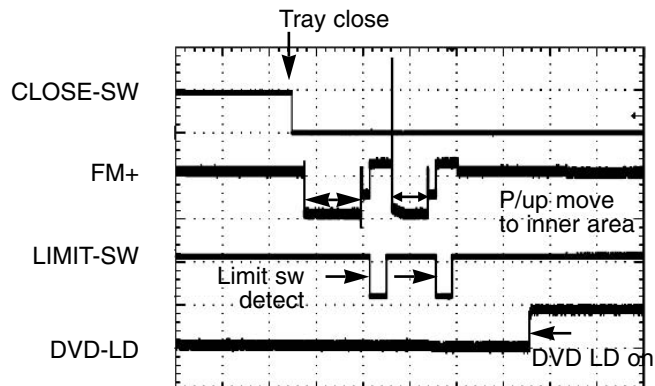
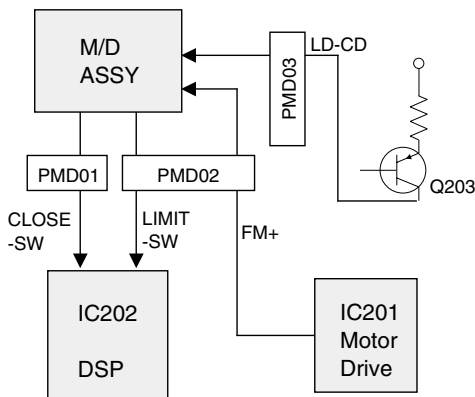

7. Checking the Video Signal

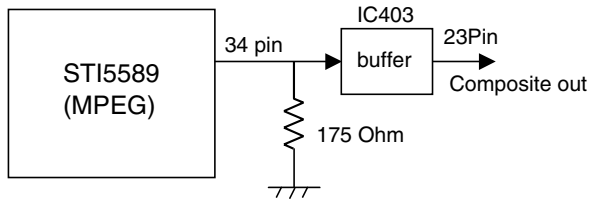

Check the followings

- 1) Check the video output mode. if the output mode is progressive - on, there is no composite signal. the output mode should be changed to progressive - off
- 2) Check the buffer IC and MPEG, and then replace.

Composite signal is normal --> Screen display OK

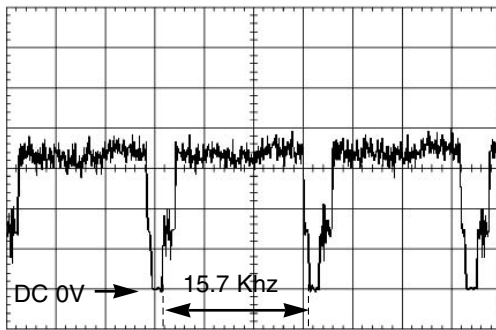

Composite signal is abnormal --> there is no screen on TV

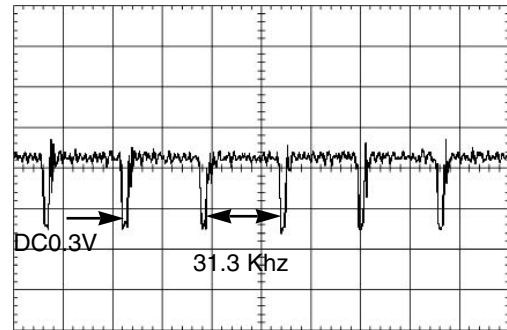

8. Checking the first step of servo (1)

Let's look over the initial step of DSP

- 1) First. DSP IC receive the DSP - Reset from MPEG
- 2) This reset signal get DSP initialized and DSP is ready to do first step for servo
- 3) PC[o] from DSP is the test signal for checking the PLL- loop

- 4) after checking the PLL-loop, the second step is followed. the second step will be explained on next page.....

if PC[o] doesn't appear, check DSP and replace.

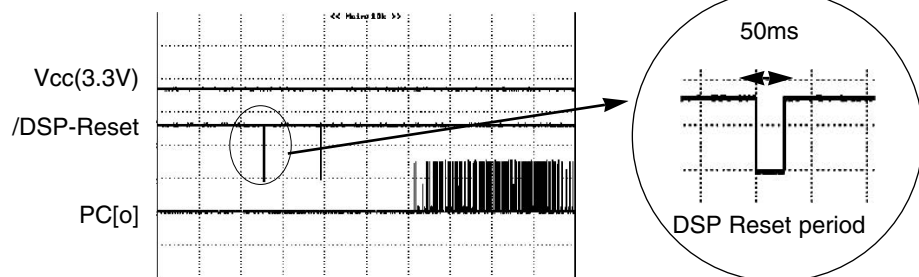
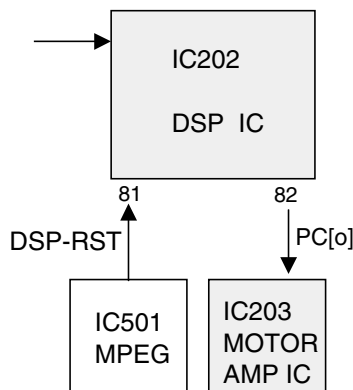

9. Checking the second step of servo (2)

Let's look over the initial step of servo

- 1) when the tray is closed, first of all, it should be checked whether there is disc or not on tray
- 2) DVD laser is turn on and the lense is moved. if there is a disc on tray, RF signal will appear
- 3) next, it should be confirmed which disc is that. CD or DVD.

4) the following step will be done continuously
DVD -Laser on -> move up/down in according to disc type, there will be RF signal...

5) after confirming disc, CD or DVD laser turn on and focus servo is executed...

the below picture is related signals when CD disc is inserted

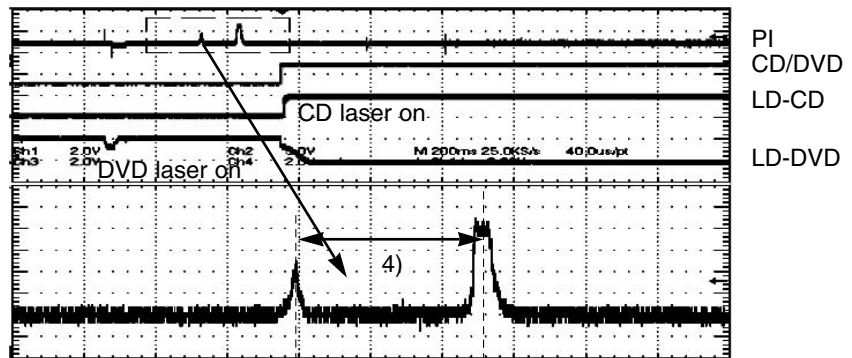
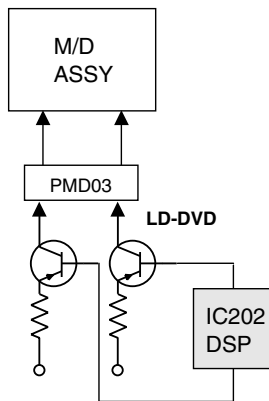

10. Checking the output of Audio signal

IC401 is called as Audio DAC, DAC means Digital-Analog Convertor.

This IC receives digital signal from MPEG and convert digital signal to analog signal, so we can hear sound...

IC401 is connected with OP - AMP and an analog Audio signal is amplified at the OP - A MP. because the analog audio signal from DAC is a very low level.

DAC_PCM_CLK : this is the system clock for IC401

DAC_SCLK : this is standard clock to synchronize the audio serial data

DAC_LRCK : R-chanel and L-chanel are selected among the audio serial data by this

DAC_PCMOUT3 : serial audio data

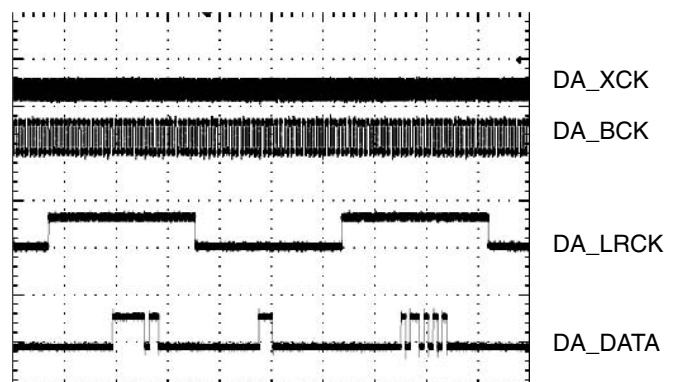
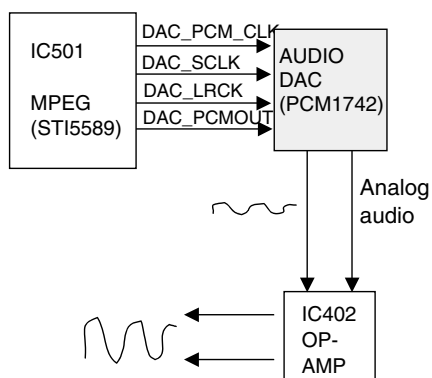

11. Checking the reset port

Pin 81 of IC202, pin 124, 186 of IC501 and pin 12 of IC503 are related to RESET.

We can know whether IC is initialized or not through those ports.

The waveform shows the status when the reset signal works normally.

If the /M-RESET is abnormal, then check the front u-com(IC901) and replace it

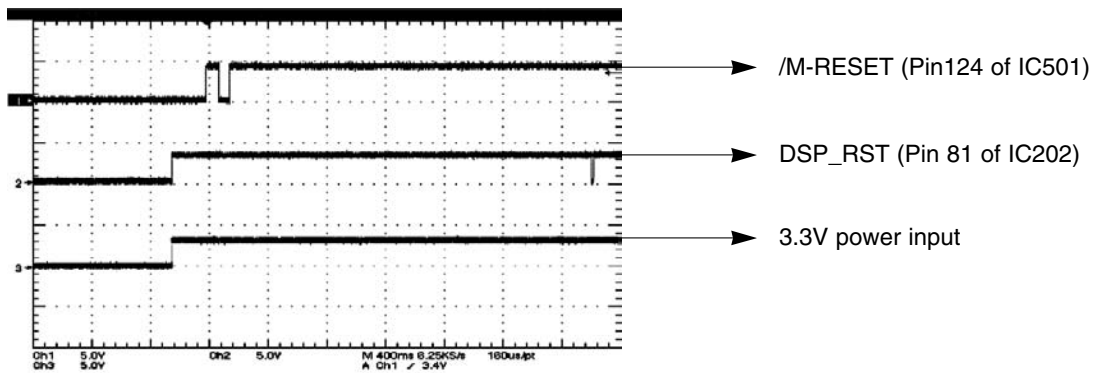

The waveform when power on

12. Checking the focus & tracking servo

Waveforms as below are regarding focusing and tracking servo normally.

FE and TE signal are generated in IC202 and output at pin55, pin54 of IC202,(TP212, TP211) respectively.

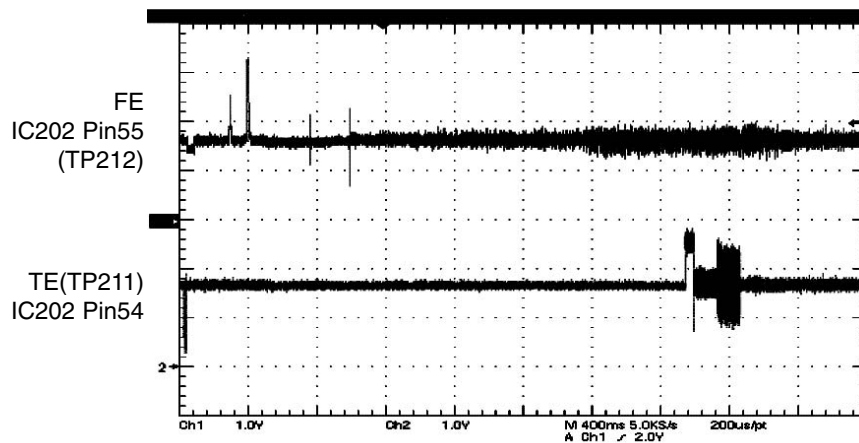

13. Checking the track jump

TE and TACT signals are output respectively from pin 54 and pin 34 of IC 202 during a normal play.

SLED signal is output pin 29 of IC 202 and flow into pin 15 and pin 18 of IC 201 to operate a sled motor when to skip chapters or to scan.

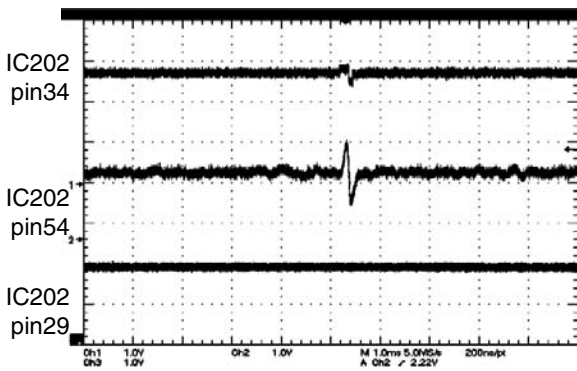

The waveform during a normal play

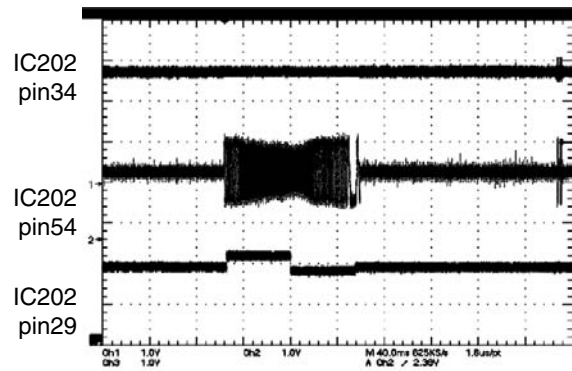

The waveform when to skip or scan

14. The status of CD_LD and DVD_LD in the PLAY MODE

The waveforms as below indicate "COLLECTOR" outputs of Q205 and Q206, respectively when to play DVD and CD

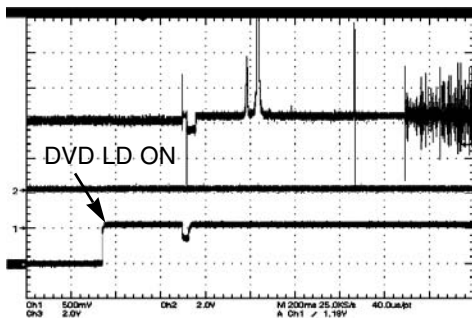

IC202
pin55
(TP212)
Q206
COLLECTOR
Q205
COLLECTOR

This is the waveform of FE and collector outputs of Q205 and Q206 when to play DVD

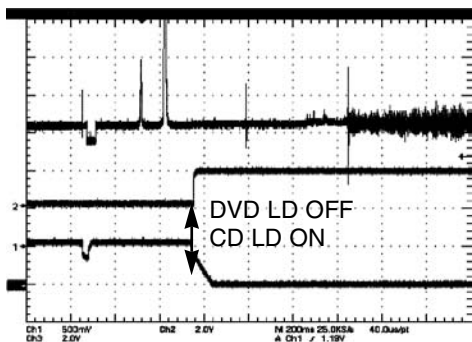

IC202
pin115
Q206
COLLECTOR
Q205
COLLECTOR

This is the waveform of FE and collector outputs of Q205 and Q206 when to play CD

15. The status Focus and spindle motor

The waveform is to display F+ signal from pin 9 IC201 and SPM+ from pin 10 IC201.

F+ is used to control a focus actuator of pick - up and SPM+ is used to operate a spindle motor. So, we can know the position of the acuator and the speed and rotating direction of the spindle motor through those signals.

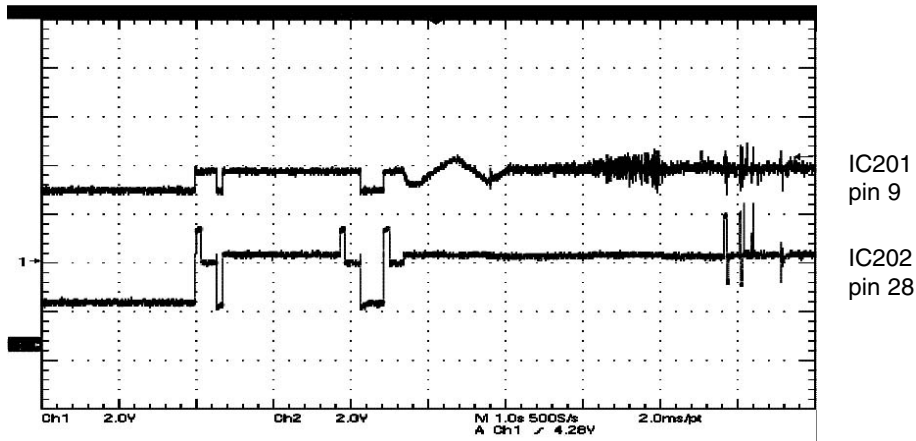

The waveform F+ and SPM+ in the PLAY Mode

16. DATA STREAM

This waveforms are showing “The Downloading serve program”.

The most important thing of the download process is the timing.

The servo program must be downloaded before the second DSP reset.

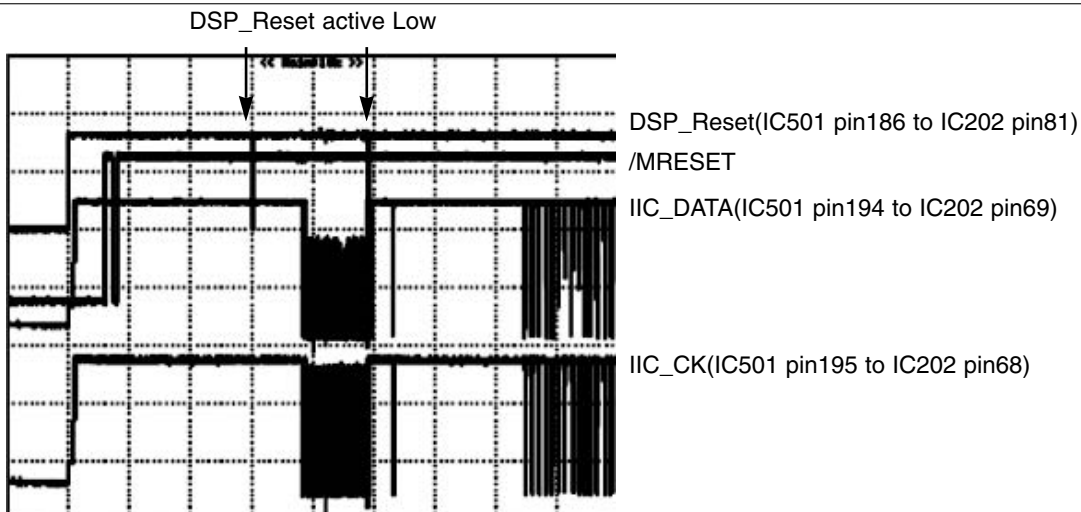

17. Input Clock to IC202

The waveform and the block diagram as below show a clock input and output between IC202 and X201.

Clocks generated in X201 is output and input into pin86 and pin87 of IC202.

The clock frequency is 20MHz.

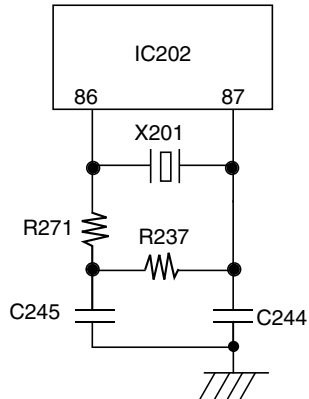

A diagram for a colck input of IC201

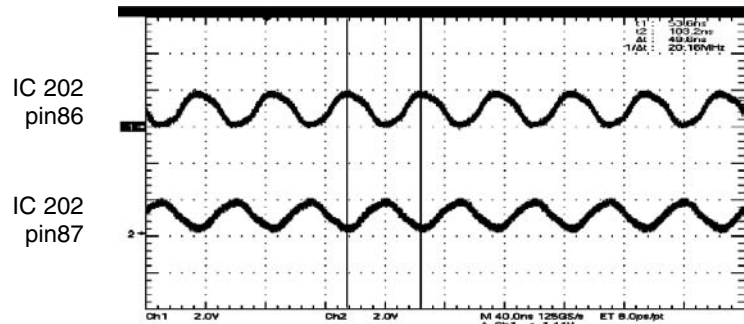

The waveform of clock inputs to IC201

18. Tray Open and Close

DSP send tray - open or tray - close signal to IC201(motor drive IC)

IC201 generates LM+ and LM - and transmits them to operate a loading motor.

if there is no LM+ or LM-, check the Tray-open and Tray-close. And replace the Motor Drive IC .

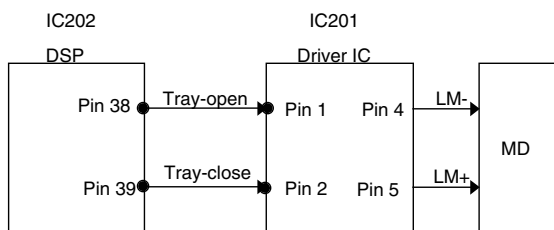

A signal flow for tray open and close

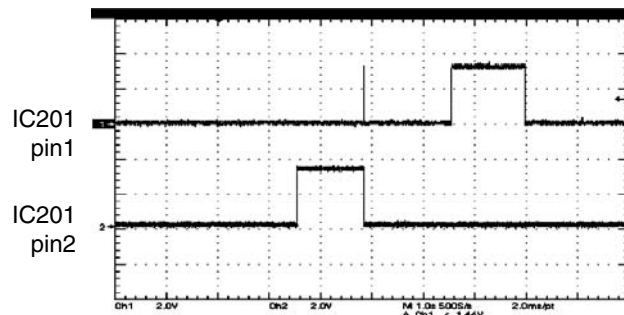

The waveform input to IC201 for tray open and close

19. Focus Drive signal(FACT)

FACT is made from focus error signal at DSP(IC202) and is input to IC201.

And then FACT is converted into F - and F+ in IC201.

Finally, they are sent to pick - up to control a focus actuator.

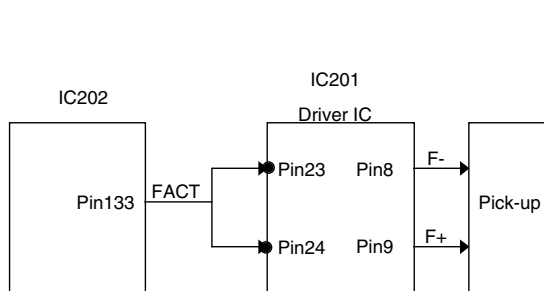

A signal flow for FACT

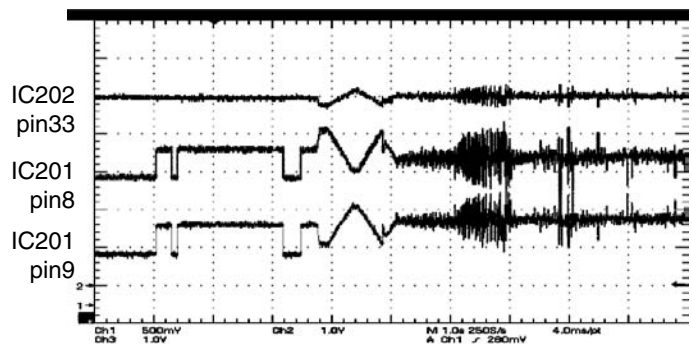

The waveform of FACT, F- and F+

20. Signals for Front micom

MRESET signal is output from front μ -COM when power is on, so IC501 is initialized.

And those(front μ -COM and IC501) communicate each other through SCKO, TXDO, RXDO signals

Waveforms display each signal when power on and after power on

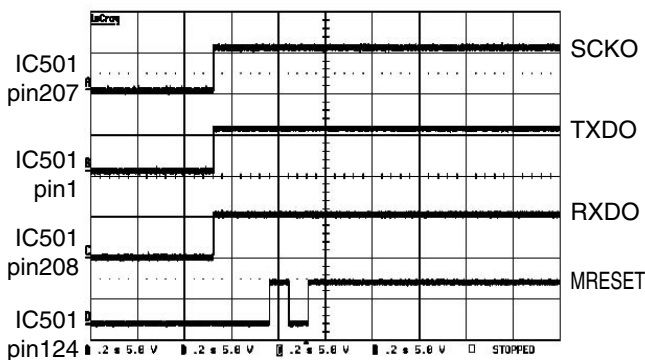

The waveform when power is on

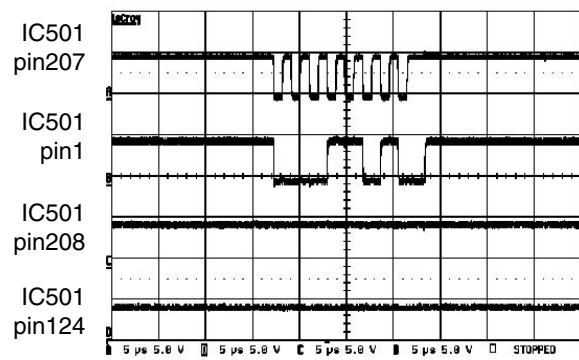

The waveform after power on

21. FACT and FE for DVD9 (Dual disc)

FE signal becomes like the waveform 2, in case of DVD dual layer disc since the laser beam is reflected on both layer 0 and layer 1.

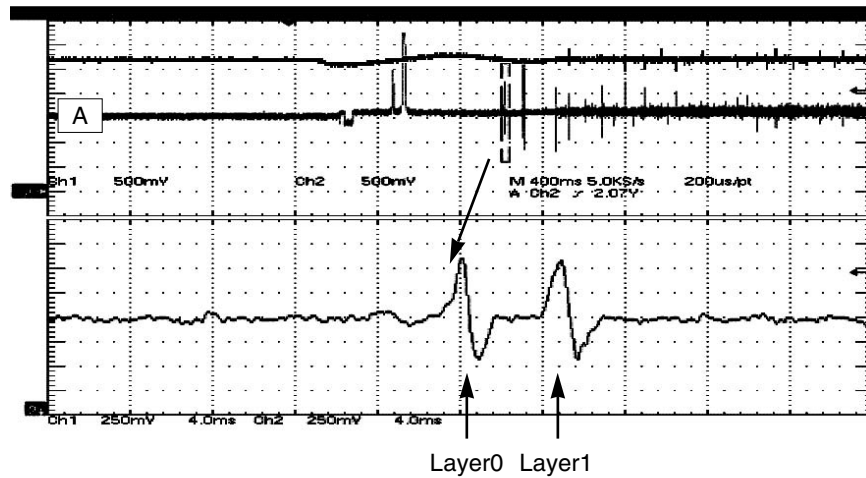

22. System clock of MPEG IC

The waveform and the block diagram as below show a clock input and output between IC501 and X501. Clocks generated in X501 is output and input into pin120 of IC501.

The clock frequency is 27MHz.

If this clock is abnormal or does not appear, replace the X-tal or MPEG IC

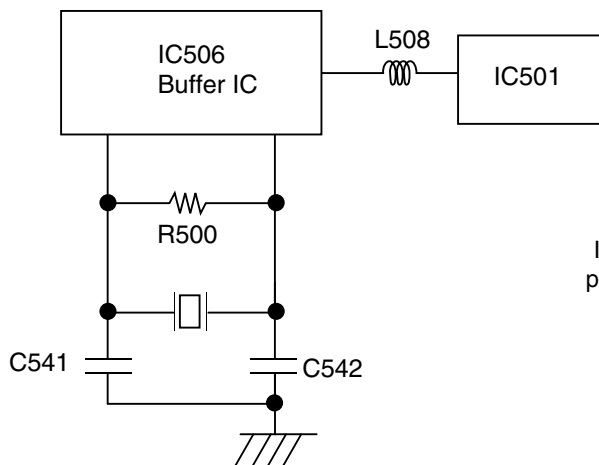

A diagram for a colck input of IC501

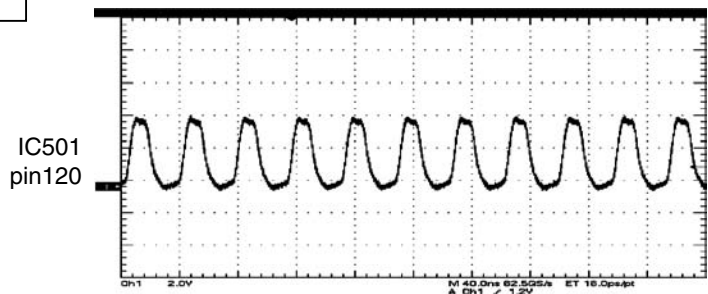

MPEG CLOCK

BLOCK DIAGRAMS

1. DVD OVERALL BLOCK DIAGRAM

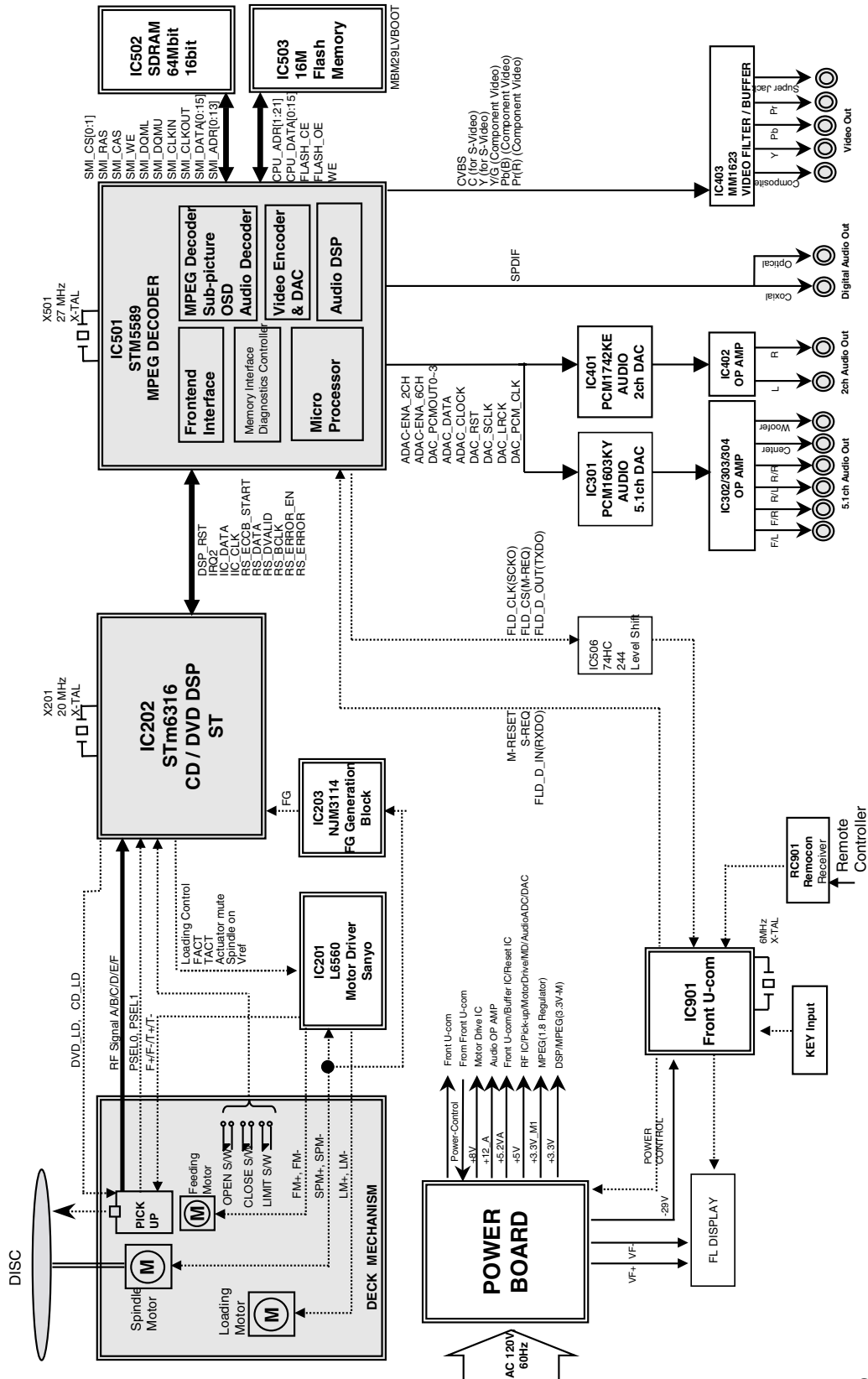

2. SERVO BLOCK DIAGRAM

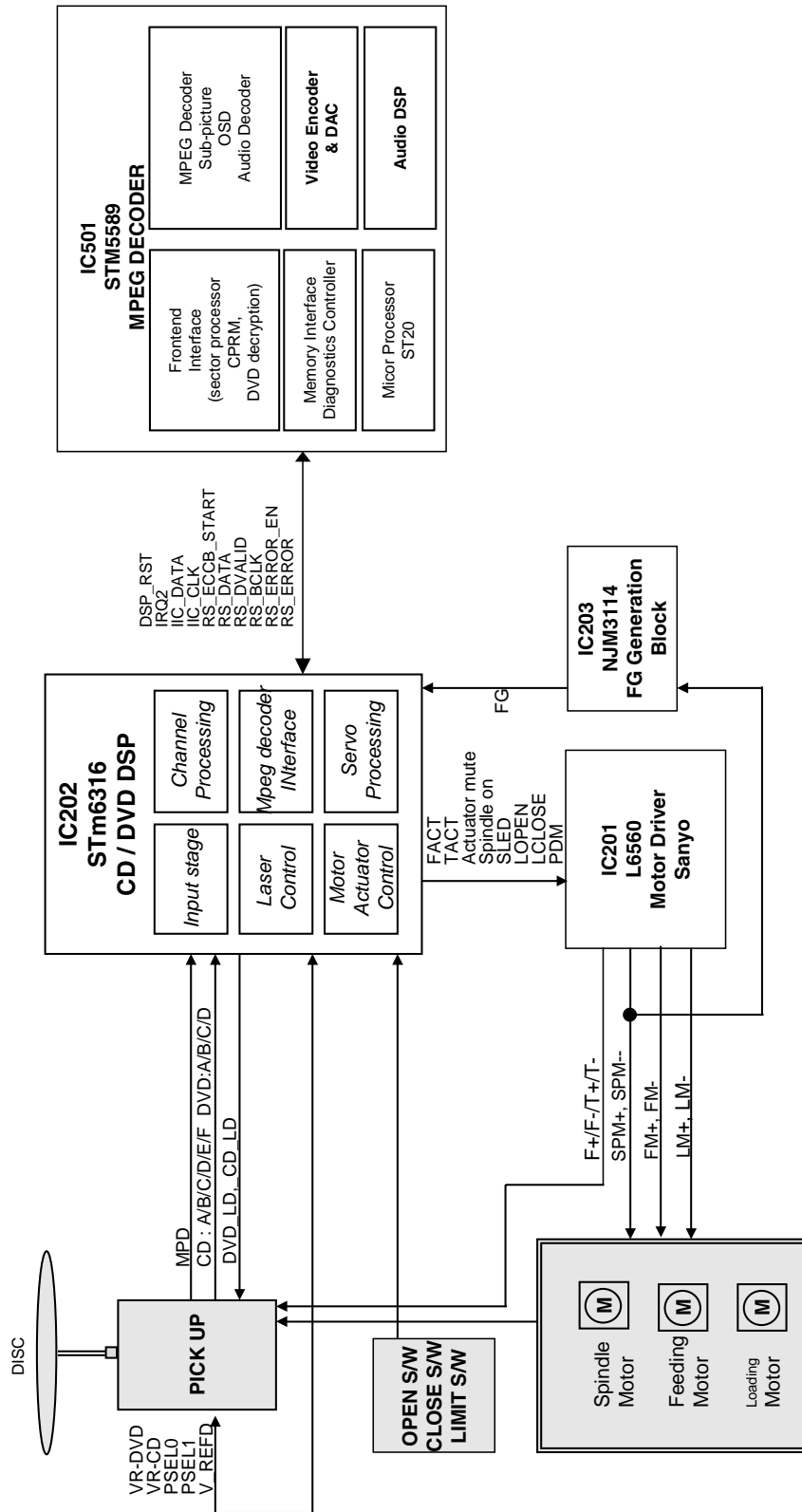

DV7732NS
STM MODEL

3. MPEG BLOCK DIAGRAM

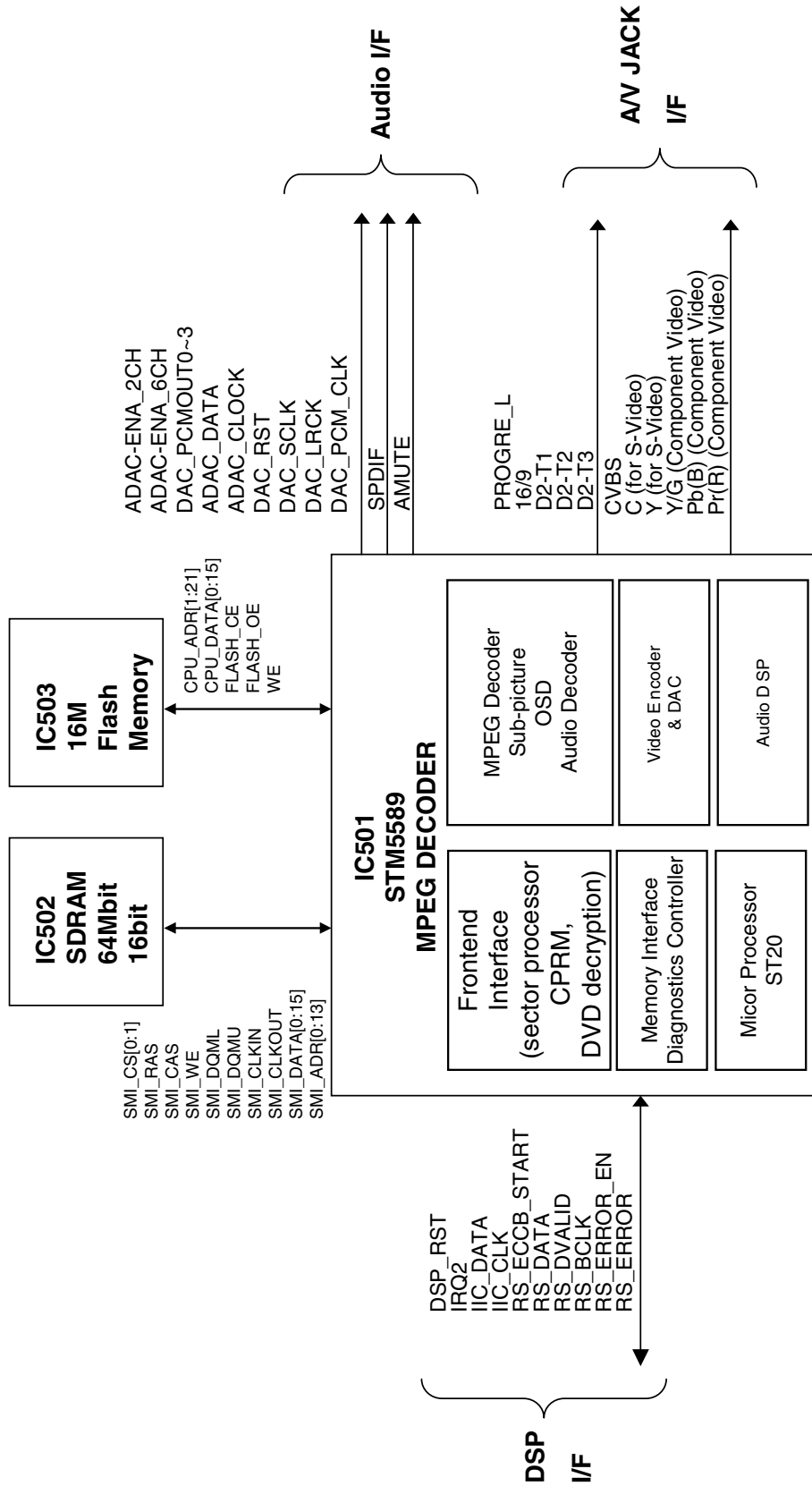

4. AUDIO Block Diagram

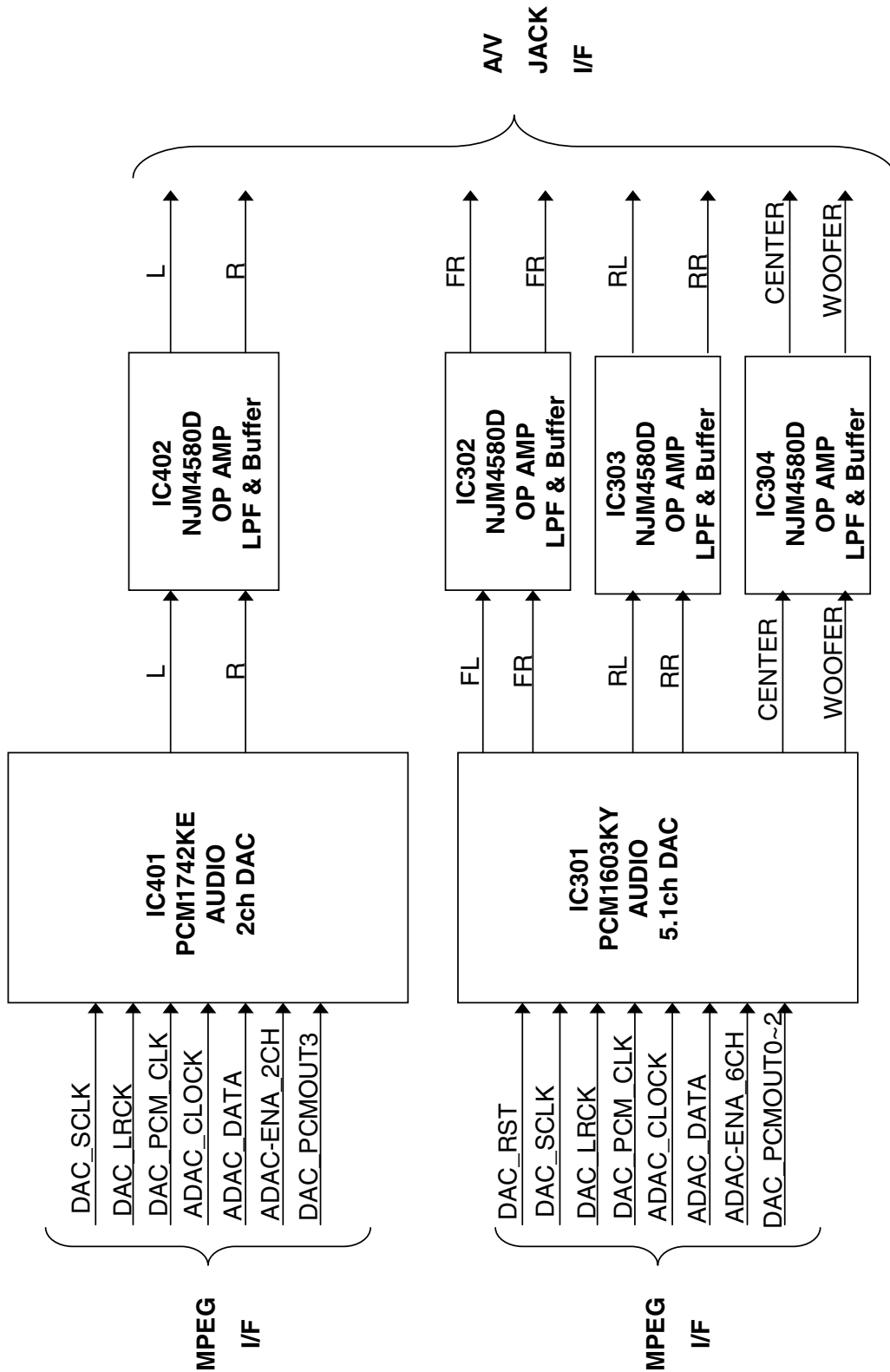

DV7732NS
STM MODEL

CIRCUIT DIAGRAM

1. POWER(SMPS) CIRCUIT DIAGRAM

IMPORTANT SAFETY NOTICE

WHEN SERVICING THIS CHASSIS, UNDER NO CIRCUMSTANCES SHOULD THE ORIGINAL DESIGN BE MODIFIED OR ALTERED WITHOUT PERMISSION FROM THE LG ELECTRONICS CORPORATION. ALL COMPONENTS SHOULD BE REPLACED ONLY WITH TYPES IDENTICAL TO THOSE IN THE ORIGINAL CIR-

CUIT. SPECIAL COMPONENTS ARE SHADED ON THE SCHEMATIC FOR EASY IDENTIFICATION. THIS CIRCUIT DIAGRAM MAY OCCASIONALLY DIFFER FROM THE ACTUAL CIRCUIT USED. THIS WAY, IMPLEMENTATION OF THE LATEST SAFETY AND PERFORMANCE IMPROVEMENT CHANGES INTO THE SET IS NOT DELAYED UNTIL THE NEW SERVICE LITERATURE IS PRINTED.

NOTE :

1. Shaded(■) parts are critical for safety. Replace only with specified part number.
2. Voltages are DC-measured with a digital voltmeter during Play mode.

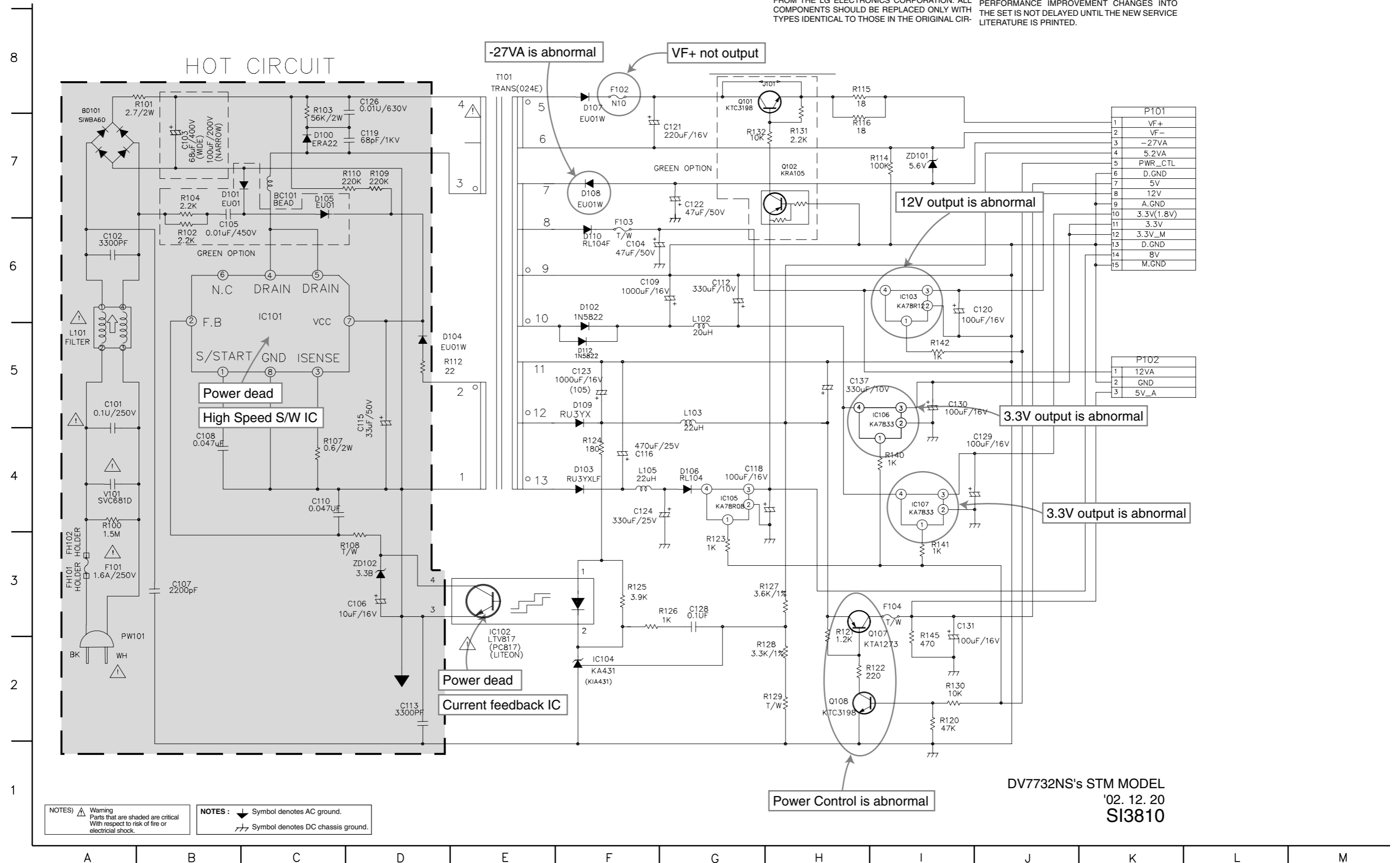

DV7732NS's STM MODEL
'02. 12. 20
SI3810

2. RF & SERVO CIRCUIT DIAGRAM

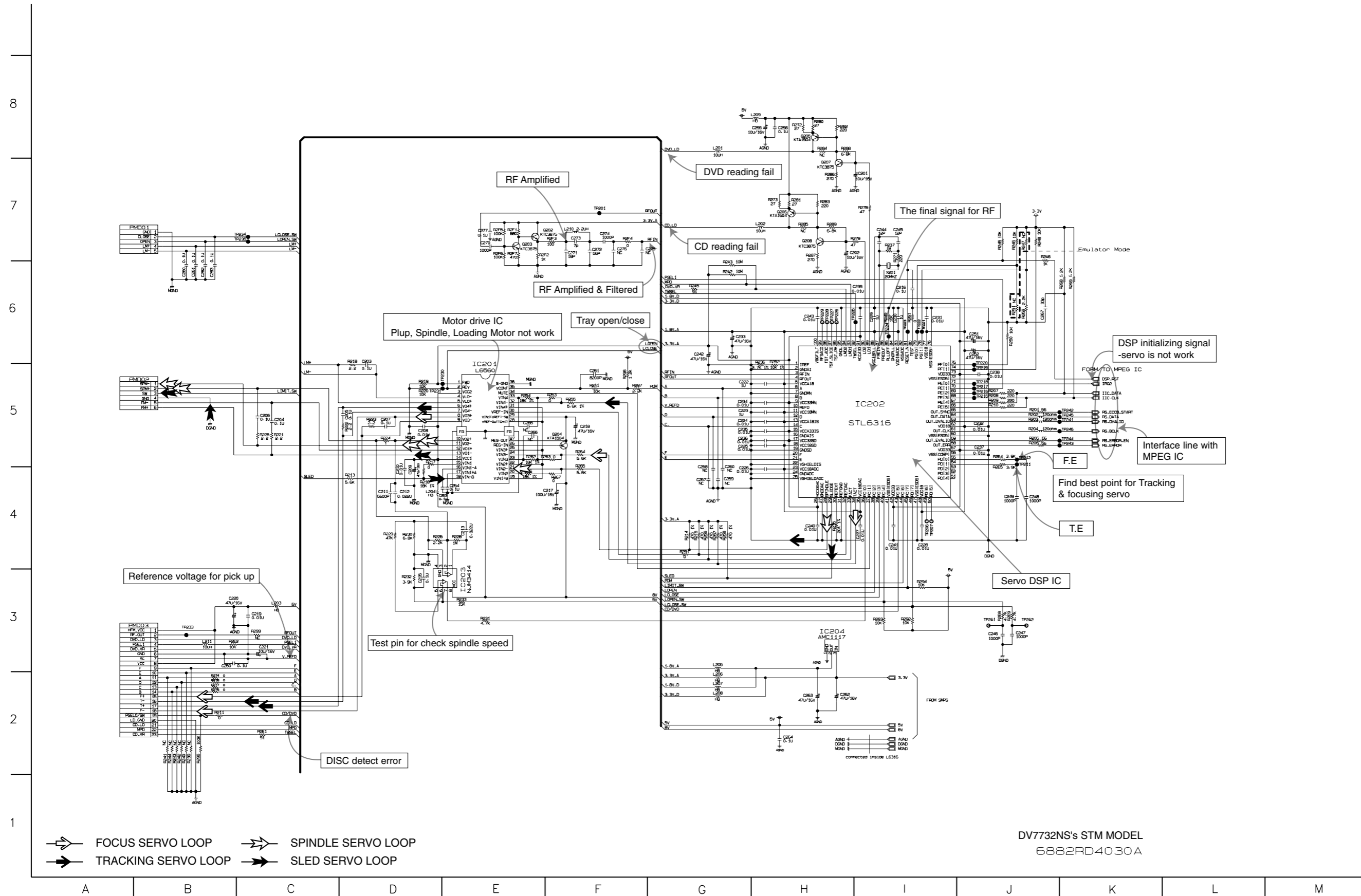

4. AUDIO & JACK CIRCUIT DIAGRAM

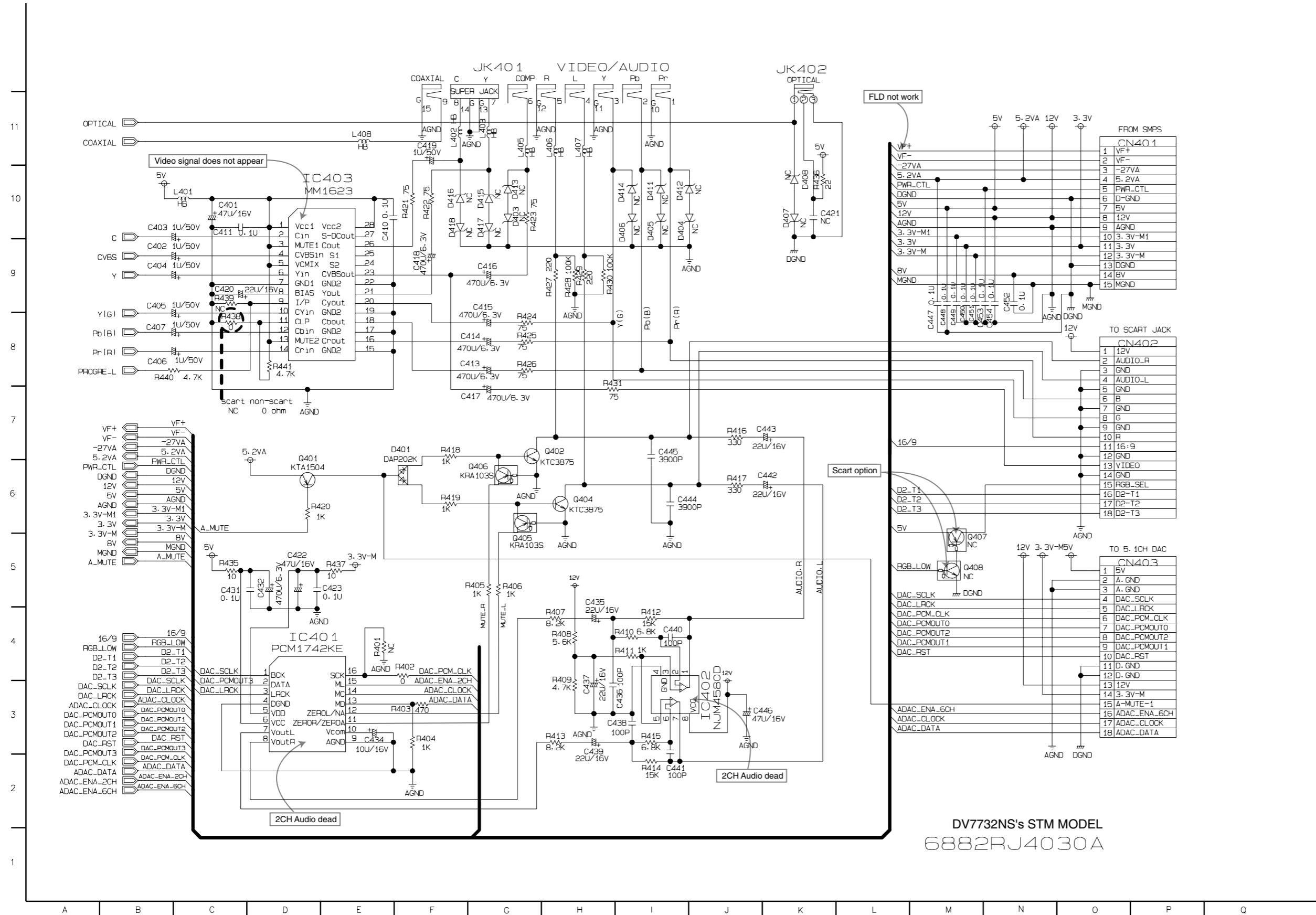

DV7732NS's STM MODEL
6882RJ4030A

5. TIMER/5.1CH CIRCUIT DIAGRAM

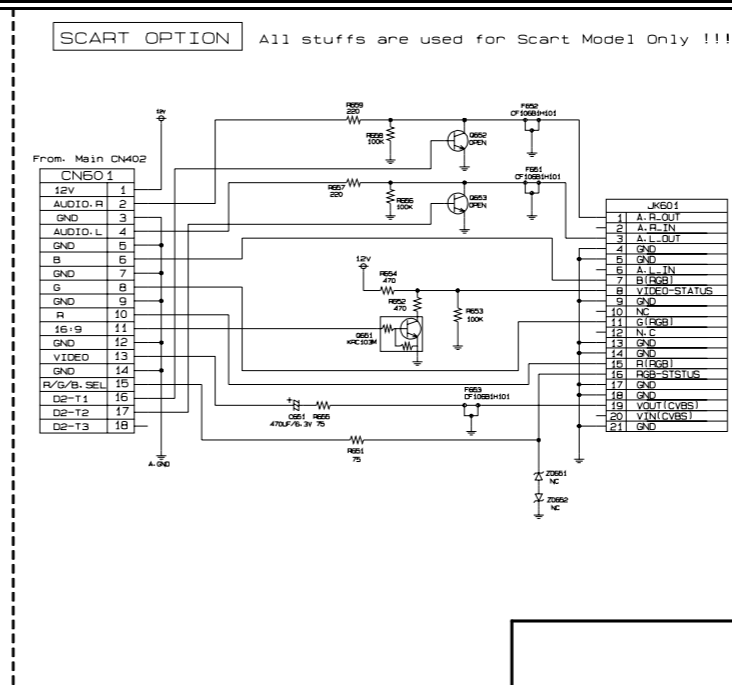
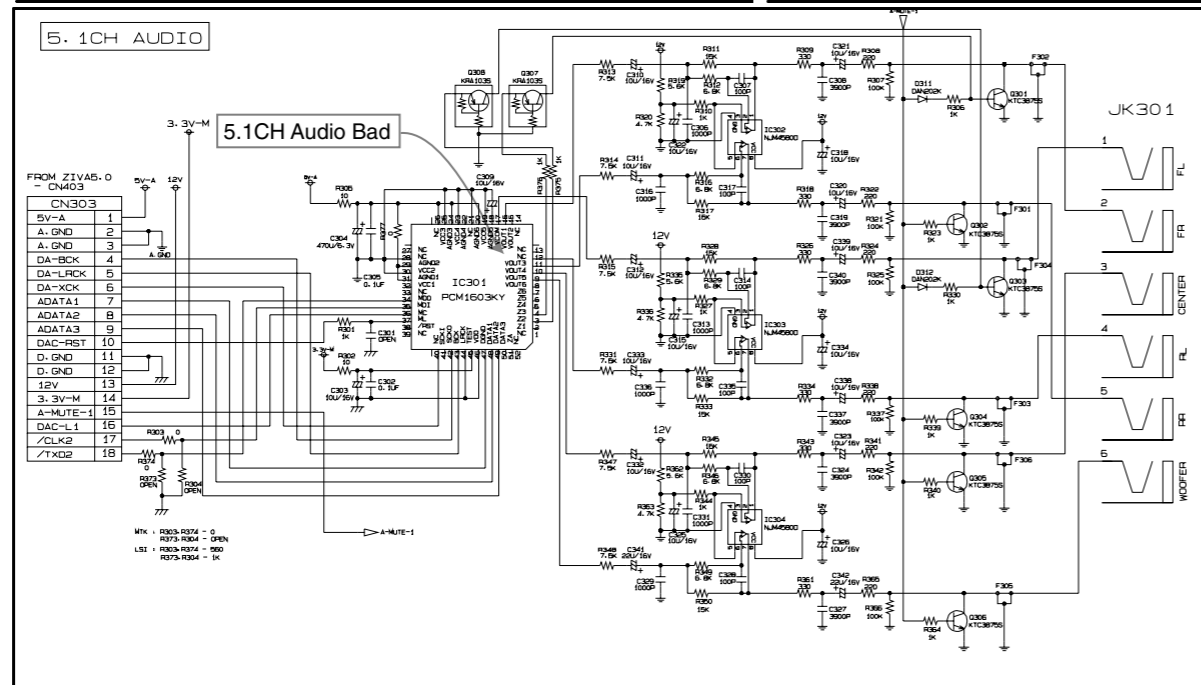
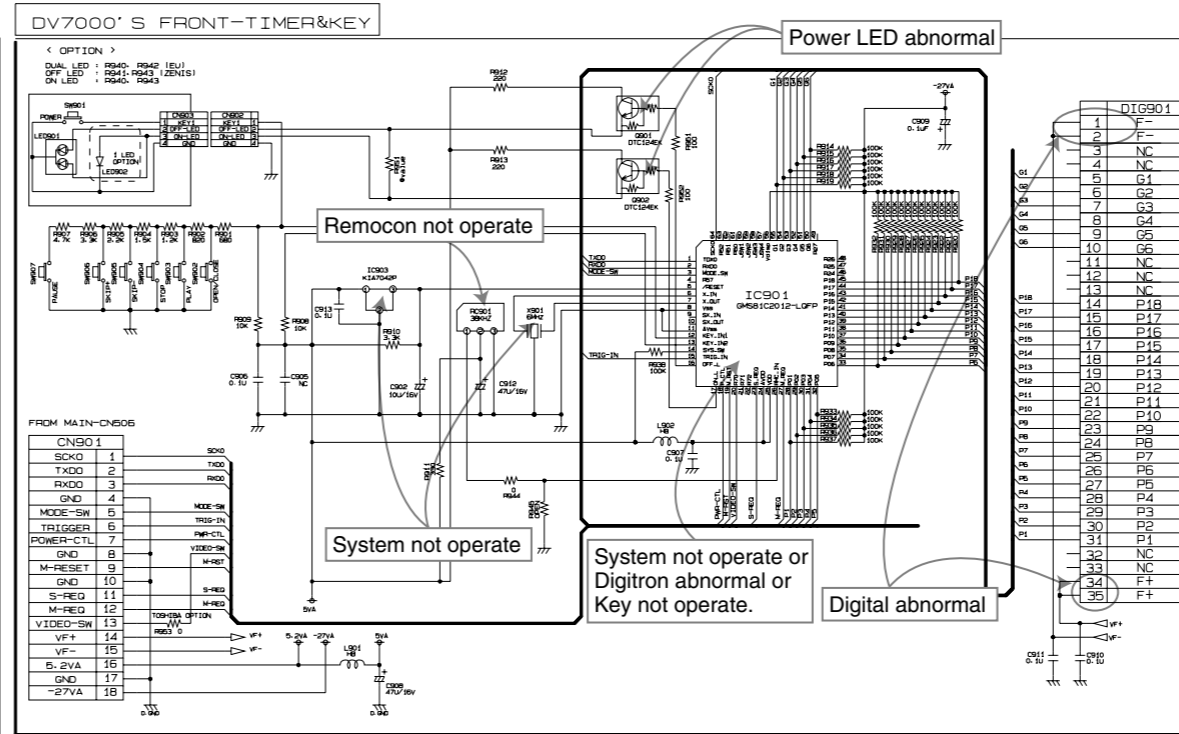
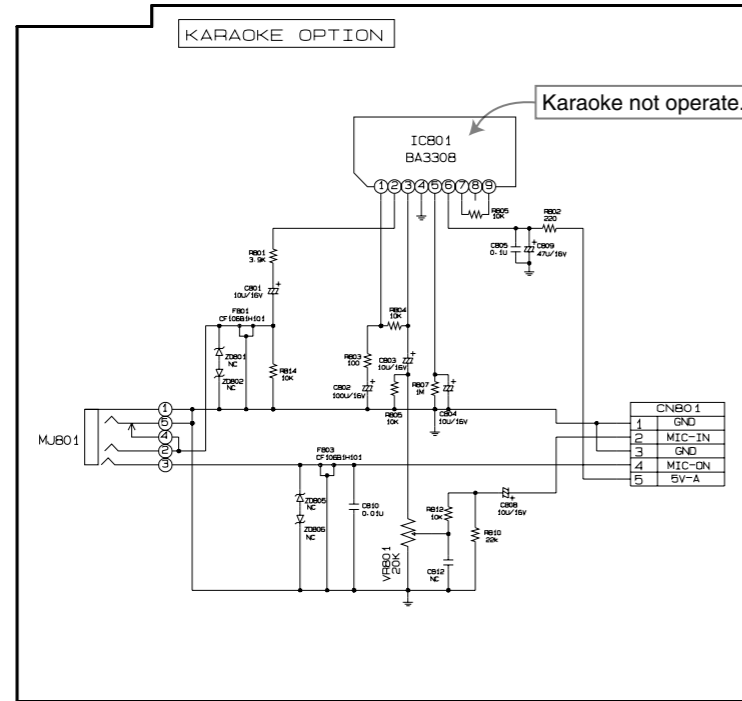

DV7732NS's STM MODEL

PIN	IC201(L6560)		IC202(STL6316)		IC203(KIA393)		IC204(BA1B8CDFP)		IC401 (PCM1742)		IC402 (NJM4580D)		IC403 (ST6436)		IC502(HY57V651620B)		IC503(AT49BV8192A)		IC504(74HCT244)		IC506(TC7W04FU)		IC508(BA1B8CDFP)	
	EE	PLAY	EE	PLAY	EE	PLAY	EE	PLAY	EE	PLAY	EE	PLAY	EE	PLAY	EE	PLAY	EE	PLAY	EE	PLAY	EE	PLAY	EE	PLAY
81			3.27	3.3																				
82			0	0																				
83			1.76	1.76																				
84			0	0																				
85			0	0																				
86			0.78	0.78																				
87			0.92	0.9																				
88			1.76	1.76																				
89			0.08	0.08																				
90			0.07	2.77																				
91			3.24	3.22																				
92			0.28	0.03																				
93			0.28	0.2																				
94			0	0.2																				
95			0	0																				
96			0	0.8																				
97			0.05	0.05																				
98			0.75	0.62																				
99			0.56	0.56																				
100			1.3	1.3																				
101																								
102																								
103																								
104																								
105																								
106																								
107																								
108																								
109																								
110																								
111																								
112																								
113																								
114																								
115																								
116																								
117																								
118																								
119																								
120																								
121																								
122																								
123																								
124																								
125																								
126																								
127																								
128																								
129																								
130																								
131																								
132																								
133																								
134																								
135																								
136																								
137																								
138																								
139																								
140																								
141																								
142																								
143																								
144																								
145																								
146																								
147																								
148																								
149																								
150																								
151																								
152																								
153																								
154																								
155																								
156																								
157																								
158																								
159																								
160																								

PRINTED CIRCUIT DIAGRAMS

1. MAIN P.C.BOARD

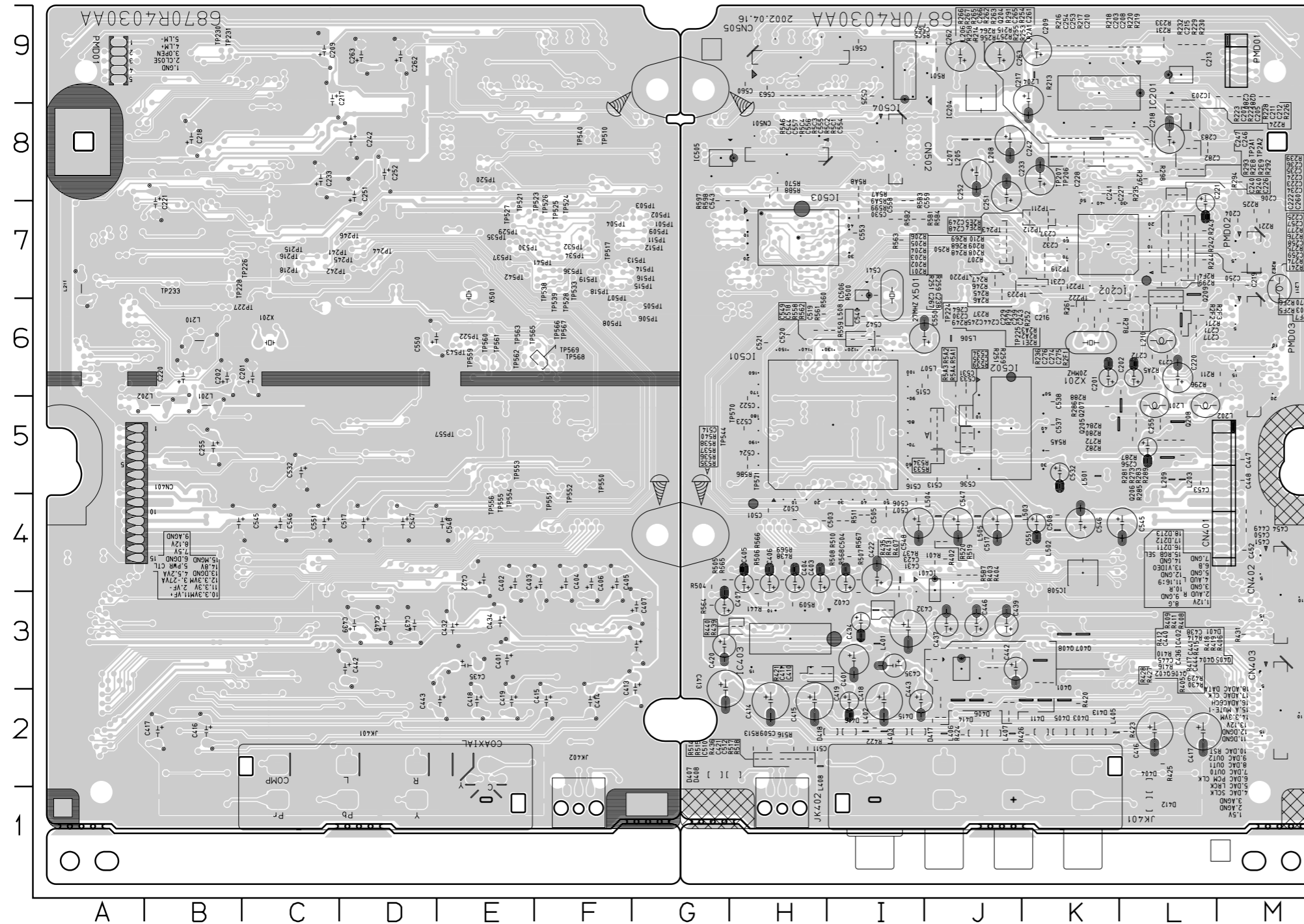

LOCATION GUIDE

TP215	C7	TP523	E7	C201	K6	C264	K6	C504	L4	D404	L2	Q206	L5	R257	K8	R406	K3	R561	H6
TP216	C7	TP524	F7	C202	K6	C265	L6	C505	L4	D405	K2	Q207	L5	R258	K8	R407	K3	R562	H6
TP218	C7	TP525	F7	C203	K9	C266	K8	C506	L4	D406	J2	Q208	L5	R259	K7	R408	J3	R563	I7
TP226	B7	TP526	F7	C204	M7	C267	K7	C507	L4	D407	G2	Q209	K2	R260	K6	R409	J3	R564	G3
TP227	B6	TP527	E7	C205	M9	C270	L6	C508	K4	D408	H2	Q210	J2	R261	K6	R410	J3	R565	H4
TP228	B7	TP528	F7	C206	M7	C271	L6	C509	H2	D411	K2	Q211	K2	R262	K8	R411	J3	R566	H4
TP230	B9	TP529	E7	C207	M9	C272	L6	C510	H2	D412	L1	Q212	K2	R263	K8	R412	J3	R567	I4
TP231	B9	TP530	E7	C208	L9	C273	L6	C511	H2	D413	K2	Q213	K2	R264	K8	R413	J3	R568	I4
TP233	B7	TP532	F7	C209	K9	C274	L7	C512	H2	D414	J2	Q214	J2	R265	K8	R414	J3	R569	H4
TP234	A9	TP533	F7	C210	K9	C275	L7	C513	J5	D415	L2	Q215	L2	R266	K8	R415	J3	R570	H8
TP235	A9	TP534	F7	C211	L8	C276	L7	C514	J5	D416	L2	Q216	J7	R267	K7	R416	J2	R571	G7
TP241	F7	TP535	E7	C212	L8	C277	L6	C515	L6	D417	L2	Q217	J7	R268	K7	R417	J2	R572	G7
TP242	D7	TP536	F7	C213	L9	C280	M9	C516	L4	D418	L2	Q218	J7	R269	K6	R418	K3	R573	H7
TP244	D7	TP537	E7	C215	L9	C281	M9	C517	J4	D419	L2	Q219	J7	R270	K6	R419	K3	R574	H7
TP245	D7	TP538	F7	C216	K6	C282	L8	C518	L6	D420	K7	Q220	K7	R271	K6	R420	K3	R575	H7
TP247	F7	TP539	F7	C217	K9	C283	L8	C519	H6	D421	K7	Q221	K7	R272	K6	R421	K3	R576	H7
TP501	G7	TP540	F8	C218	L8	C401	L3	C520	H6	D422	L7	Q222	J7	R273	L5	R422	L2	R577	J5
TP502	G7	TP541	E7	C219	M7	C402	L4	C521	H6	D423	L7	Q223	J7	R274	L5	R423	L2	R578	J5
TP503	G7	TP542	E7	C220	L6	C403	H4	C522	H6	D424	J3	Q224	J7	R275	L5	R424	L2	R579	J5
TP504	F7	TP543	E6	C221	L7	C404	H4	C523	H6	D425	H3	Q225	K7	R276	K6	R425	L2	R580	J5
TP505	G6	TP544	F5	C222	L7	C405	H4	C524	H6	D426	L5	Q226	M7	R277	K6	R426	K2	R581	J5
TP506	G6	TP545	F5	C223	L7	C406	H4	C525	L9	D427	J5	Q227	J5	R278	K6	R427	L2	R582	J5
TP507	F7	TP546	F4	C224	L7	C407	G3	C526	L7	D428	H7	Q228	H7	R279	K6	R428	L2	R583	J5
TP508	F7	TP547	F5	C225	L7	C408	G3	C527	L7	D429	H7	Q229	H7	R280	K6	R429	L2	R584	J5
TP509	F7	TP548	F5	C226	L7	C409	H3	C528	K5	D430	H7	Q230	H7	R281	K6	R430	L2	R585	J5
TP510	F8	TP549	F5	C227	K8	C413	G2	C529	J6	D431	H7	Q231	H7	R282	K6	R431	M3	R586	J5
TP511	F7	TP550	F5	C228	K8	C414	H2	C530	J6	D432	H7	Q232	H7	R283	K6	R432	M3	R587	J5
TP512	G7	TP551	F5	C229	K6	C415	H2	C531	J6	D433	H7	Q233	H7	R284	K6	R433	M3	R588	J5
TP513	F7	TP552	F5	C230	K6	C416	L2	C532	J6	D434	H7	Q234	H7	R285	K6	R434	M3	R589	J5
TP514	G7	TP553	F5	C231	K7	C417	L2	C533	K5	D435	L5	Q235	M7	R286	K5	R435	M3	R590	J5
TP515	F7	TP554	F5	C232	K7	C418	L2	C534	K5	D436	L5	Q236	M7	R287	K5	R436	M3	R591	J5
TP516	F7	TP555	F5	C233	K8	C419	L2	C535	L6	D437	L5	Q237	M9	R288	K5	R437	M3	R592	J5
TP517	F7	TP556	F5	C234	L7	C420	G3	C536	L7	D438	K9	Q238	L6	R289	K5	R438	M3	R593	J5
TP518	F7	TP557	F5	C235	L7	C421	H2	C537	J5	D439	H7	Q239	L6	R290	K5	R439	M3	R594	J5
TP519	F7	TP558	F5	C236	L7	C422	L4	C538	J5	D440	H7	Q240	L6	R291	K5	R440	M3	R595	J5
TP520	F7	TP559	F5	C237	K7	C423	L4	C539	K5	D441	L2	Q241	M9	R292	K5	R441	M3	R596	J5
TP521	E7	TP560	F6	C238	K7	C424	L4	C540	L7	D442	L7	Q242	M9	R293	K5	R442	M3	R597	J5
TP522	E7	TP561	F6	C239	K6	C425	L4	C541	L7	D443	L7	Q243	M9	R294	K5	R443	M3	R598	J5
C240	L8	C434	L3	C542	L6	D444	L6	Q244	L6	R295	K5	R444	M3	R599	J5	R600	J5	R601	J5
C241	K8	C435	L3	C543	L6	D445	L6	Q245	L6	R296	K5	R445	M3	R602	J5	R603	J5	R604	J5
C242	J8	C436	J3	C544	L6	D446	L6	Q246	L6	R297	K5	R446	M3	R605	J5	R606	J5	R607	J5
C243	L8	C437	J3	C545	L6	D447	L6	Q247	L6	R298	K5	R447	M3	R608	J5	R609	J5	R610	J5
C244	K6	C438	J3	C546	L6	D448	L6	Q248	L6	R299	K5	R448	M3	R611	J5	R612	J5	R613	J5
C245	K6	C439	J3	C547	L6	D449	L6	Q249	L6	R300	K5	R449	M3	R614	J5	R615	J5	R616	J5
C246	L8	C440	J3	C548	L6	D450	L6	Q250	L6	R301	K5	R450	M3	R617	J5	R618	J5	R619	J5
C247	L8	C441	J3	C549	L6	D451	L6	Q251	L6	R302	K5	R451	M3	R620	J5	R621	J5	R622	J5
C248	K7	C442	J3	C550	L6	D452	L6	Q252	L6	R303	K5	R452	M3	R623	J5	R624	J5	R625	J5
C249	K7	C443	J3	C551	L6	D453	L6	Q253	L6	R304	K5	R453	M3	R626	J5	R627	J5	R628	J5
C250	M7	C444	J2	C552	L6	D454	L6	Q254	L6	R305	K5	R454	M3	R629	J5	R630	J5	R631	J5
C251	J8	C445	J2	C553	L6	D455	L6	Q255	L6	R306	K5	R455	M3	R632	J5	R633	J5	R634	J5
C252	L5	C446	J2	C554	L6	D456	L6	Q256	L6	R307	K5	R456	M3	R635	J5	R636	J5	R637	J5
C253	K9	C447	M5	C555	L6	D457	L6	Q257	L6	R308	K5	R457	M3	R638	J5	R639	J5	R640	J5
C254	K9	C448	M5	C556	L6	D458	L6	Q258	L6	R309	K5	R458	M3	R641	J5	R642	J5	R643	J5
C255	L5	C449	M4	C557	L6	D459	L6	Q259	L6	R310	K5	R459	M3	R644	J5	R645	J5	R646	J5
C256	L5	C450	M4	C558	L6	D460	L6	Q260	L6	R311	K5	R460	M3	R647	J5	R648	J5	R649	J5
C257	L5	C451	M4	C559	L6	D461	L6	Q261	L6	R312	K5	R461	M3	R650	J5	R651	J5	R652	J5
C258	L7	C452	M4	C560	L6	D462	L6	Q262	L6	R313	K5	R462	M3	R653	J5	R654	J5	R655	J5
C259	L7	C453	M4	C561	L6	D463	L6	Q263	L6	R314	K5	R463	M3	R656	J5	R657	J5	R658	J5
C260	L7	C454	M4	C562	L6	D464	L6	Q264	L6	R315	K5	R464	M3	R659	J5	R660	J5	R661	J5
C261	L8	C501	H4	C563	L6	D465	L6	Q265	L6	R316	K5	R465	M3	R662	J5	R663	J5	R664	J5
C262	J9	C502	H4	C564	L6	D466	L6	Q266	L6	R317	K5	R466	M3	R665	J5	R666	J5	R667	J5
C263	J9	C503	H4	C565	L6	D467	L6	Q267	L6	R318	K5	R467	M3	R668	J5	R669	J5	R670	J5

2. KEY P.C.BOARD

(5 TOOL ONLY)

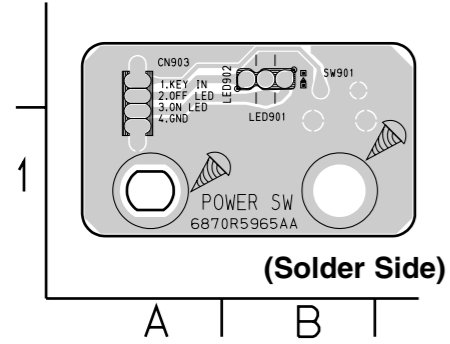

(8 TOOL ONLY)

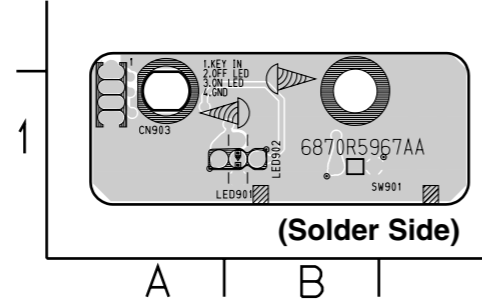

3. TIMER P.C.BOARD

(5 TOOL ONLY)

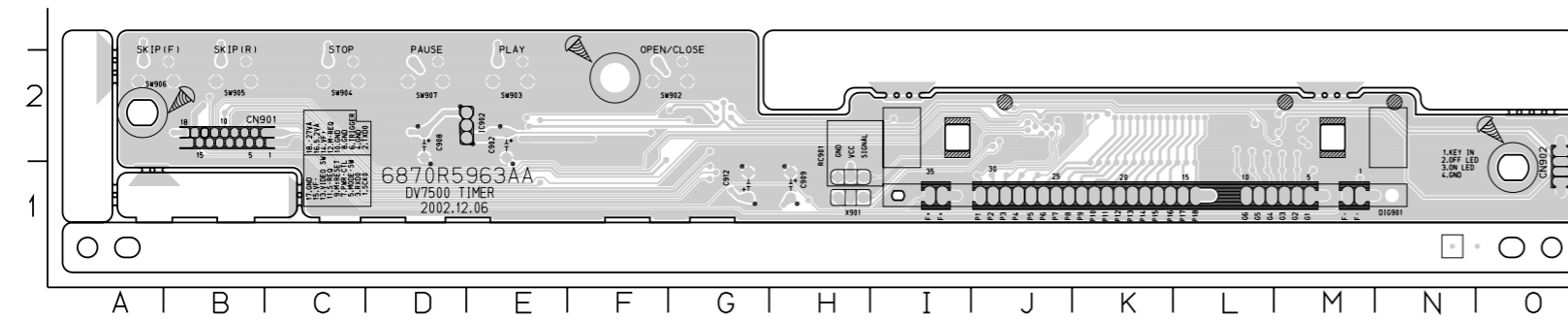

C902	E2	R916	M1
C906	G2	R917	M1
C907	K2	R918	M1
C908	D2	R919	M1
C909	H1	R920	L1
C910	H1	R921	L1
C911	M1	R922	L1
C912	G1	R923	K1
C913	D2	R924	K1
CN901	C2	R925	K1
CN902	O2	R926	K1
DIG901	M1	R927	K1
IC901	J2	R928	K1
IC902	E2	R929	K1
L901	D2	R930	K1
Q901	M2	R931	K1
Q902	M2	R932	K1
R901	F2	R933	J1
R902	E3	R934	J1
R903	D3	R935	J1
R904	C3	R936	J1
R905	B3	R937	I1
R906	B2	R938	G2
R907	D2	R940	L2
R908	G2	R944	C2
R909	G2	RC901	H1
R910	E2	SW902	G2
R911	G1	SW903	E2
R912	M2	SW904	C2
R913	M2	SW905	B2
R914	L1	SW906	A2
R915	L1	SW907	D2
		X901	H1

(8 TOOL ONLY)

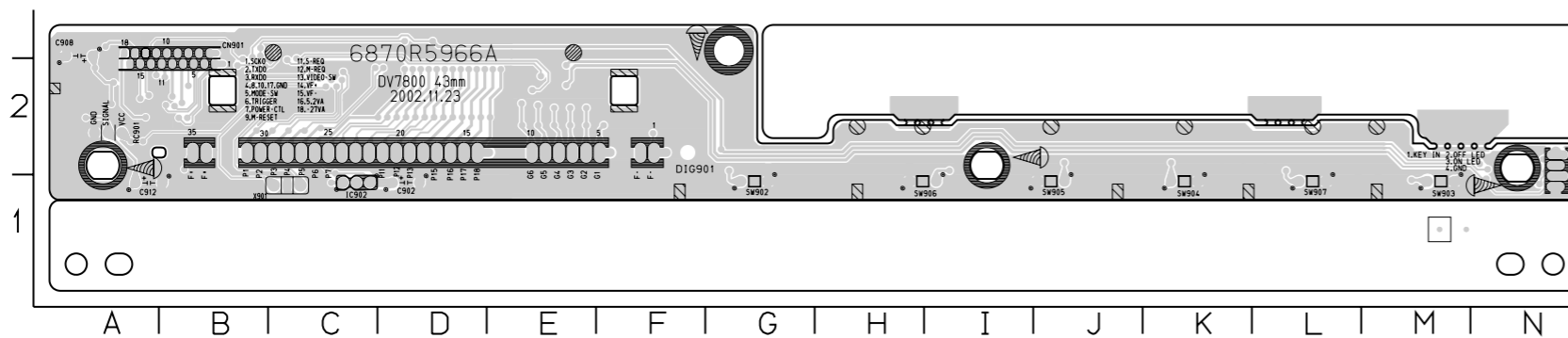

LOCATION GUIDE

C902	D1	Q902	E2	R917	E2	R935	C2
C905	D3	R901	G2	R918	E2	R936	B2
C906	D3	R902	K2	R919	F2	R937	B2
C907	C3	R903	K2	R920	E2	R938	B3
C908	A3	R904	J2	R921	D2	R944	A2
C909	C2	R905	J2	R922	D2	R945	A2
C910	B2	R906	J1	R923	D2	R951	E2
C911	F2	R907	K1	R924	D2	R952	E2
C912	A1	R908	D3	R925	D2	R953	C3
C913	C1	R909	D3	R926	D2	R951	M2
CN901	B2	R910	C1	R927	D2	RC901	A2
CN902	N2	R911	A2	R928	D2	SW902	G1
DIG901	F2	R912	F2	R929	D2	SW903	M1
IC901	C2	R913	F2	R930	D2	SW904	K1
IC902	C1	R914	E2	R931	D2	SW905	J1
L901	A2	R915	E2	R932	D2	SW906	H1
L902	B3	R916	E2	R933	C2	SW907	L1
Q901	E2			R934	C2	X901	C1

(Solder Side)

4. SCART & 5.1CH P.C.BOARD

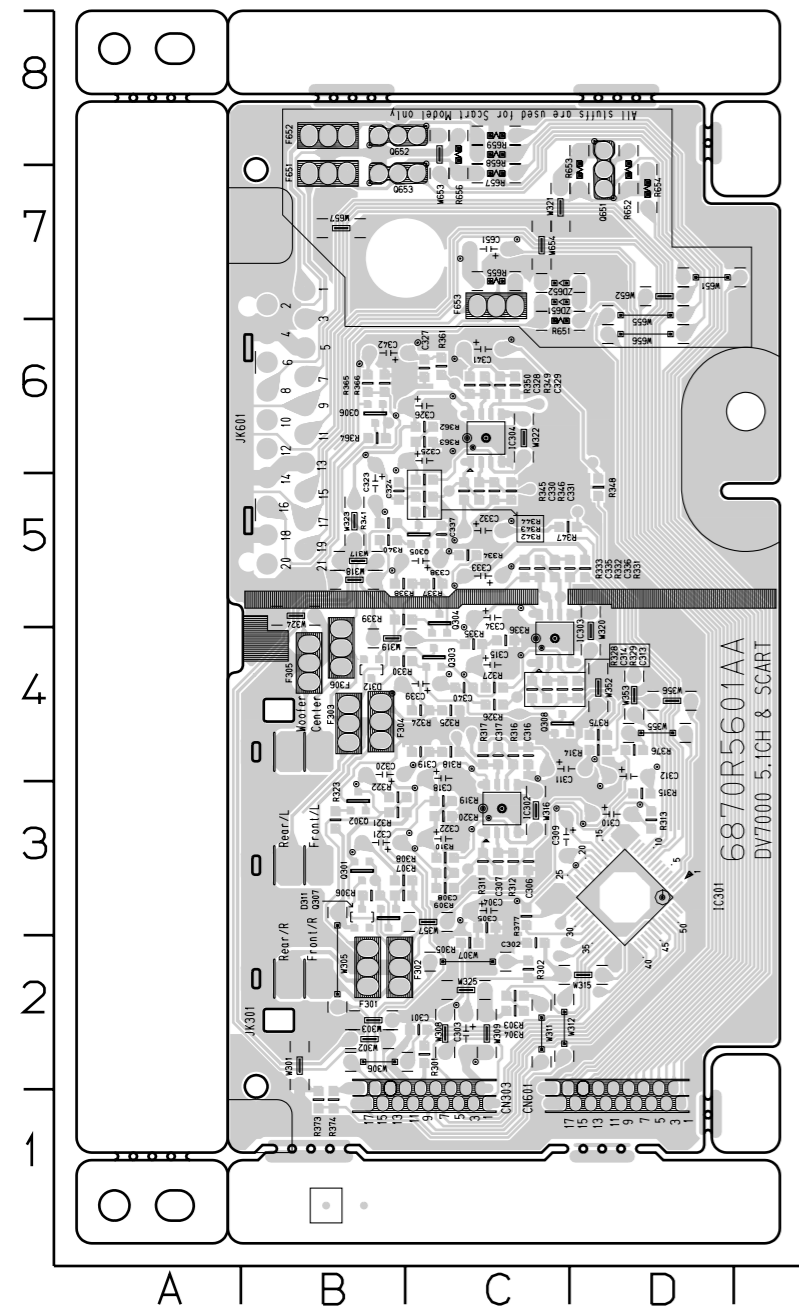

LOCATION GUIDE

C303	C2
C304	C3
C309	C3
C310	D3
C311	C4
C312	D4
C315	C4
C318	C4
C320	B4
C321	B3
C322	C3
C323	B5
C325	C6
C326	C6
C332	C5
C333	C5
C334	C5
C338	C5
C339	C4
C341	C6
C342	B6
C651	C7
CN303	C1
CN601	D1
F301	B2
F302	B2
F303	B4
F304	B4
F305	B4
F306	B4
F651	B7
F652	B8
F653	C7
JK301	B3
JK601	B6
Q651	D7
Q652	B8
Q653	B7
R651	C6
R652	D7
R653	D7
R654	D7
R655	C7
R656	C8
R657	C7
R658	C8
R659	C8
ZD651	C7
ZD652	C7

(Solder Side)

5. POWER(SMPS) P.C.BOARD

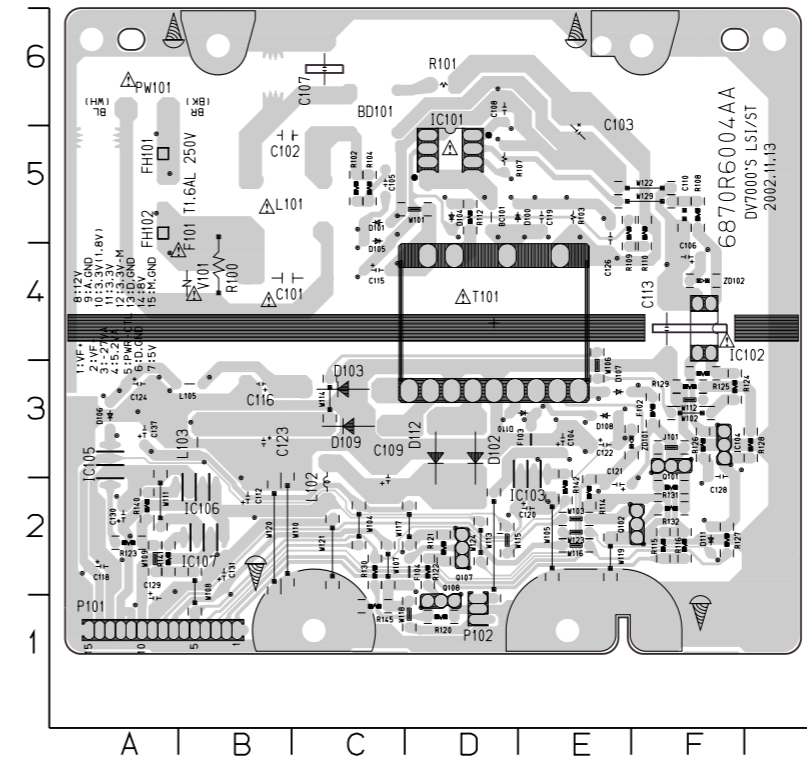

NOTES) ⚠ Warning
Parts that are shaded are critical
With respect to risk of fire or
electrical shock.

LOCATION GUIDE

BC101	D5	D105	C5	R102	C5
BD101	C6	D106	A3	R103	E5
C101	B4	D107	E3	R104	C5
C102	B5	D108	E3	R107	D5
C103	E5	D109	C3	R108	F5
C104	E3	D110	E3	R109	F5
C105	C5	D111	F2	R110	F5
C106	F4	D112	D3	R112	D5
C107	C6	F102	F3	R114	E2
C108	D6	F103	E3	R115	F2
C109	C2	F104	D2	R116	F2
C110	F5	FH101	A5	R120	D1
C112	B2	FH102	A5	R121	D2
C113	F4	IC101	D5	R122	D2
C115	C4	IC102	F4	R123	A2
C116	B3	IC103	D3	R124	F3
C118	A2	IC104	F3	R125	F3
C119	E5	IC105	A3	R126	F3
C120	E2	IC106	B2	R127	F2
C121	E2	IC107	B2	R128	G3
C122	E3	J101	F3	R129	F3
C123	B3	L101	B5	R130	C2
C124	A3	L102	C2	R131	F2
C126	E5	L103	B3	R132	F2
C128	F3	L105	B3	R140	A2
C129	A1	P101	B1	R141	A2
C130	A2	P102	D1	R142	E2
C131	B2	PW101	A6	R145	C1
C137	A3	Q101	F3	T101	D4
D100	D5	Q102	F2	V101	B4
D101	C5	Q107	D2	ZD101	F3
D102	D3	Q108	D1	ZD102	F4
D103	C3	R100	B4		
D104	D5	R101	D6		

SECTION 4 MECHANISM

CONTENTS

DECK MECHANISM PARTS LOCATIONS

- Top View.....4-1
- Top View(without Tray Disc)4-1
- Bottom View4-1

DECK MECHANISM DISASSEMBLY

1. Holder Clamp.....4-2
 - 1-1. Clamp Assembly Disc.....4-2
 - 1-1-1. Plate Clamp4-2
 - 1-1-2. Magnet Clamp4-2
 - 1-1-3. Clamp Upper.....4-2
2. Tray Disc4-2
3. Base Assembly Sled4-3
 - 3-1. Gear Assembly Feed4-3
 - 3-2. Gear Assembly Middle.....4-3
 - 3-3. Gear Assembly Rack4-3
4. Rubber Rear.....4-3

5. Frame Assembly Up/Down.....4-4
6. Belt Loading.....4-4
7. Gear Pulley4-4
8. Gear Loading4-4
9. Guide Up/Down.....4-4
10. PWB Assembly Loading4-4
11. Base Main.....4-4

EXPLODED VIEW

1. Deck Mechanism Exploded View....4-5
-

DECK MECHANISM PARTS LOCATION

• Top View (With Tray)

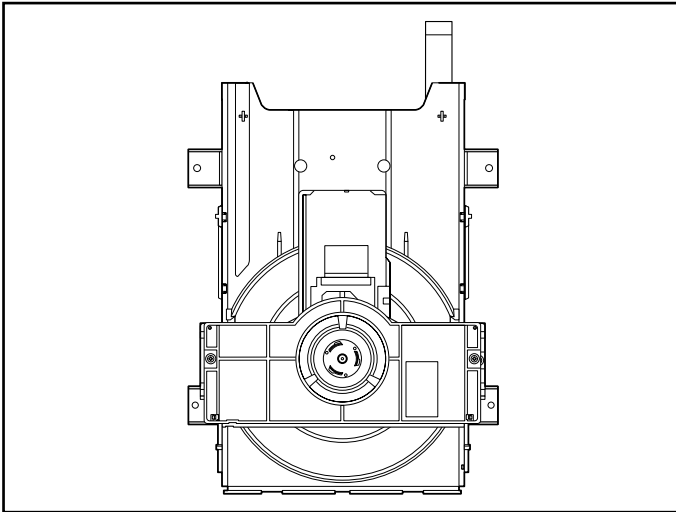

• Top View (Without Tray)

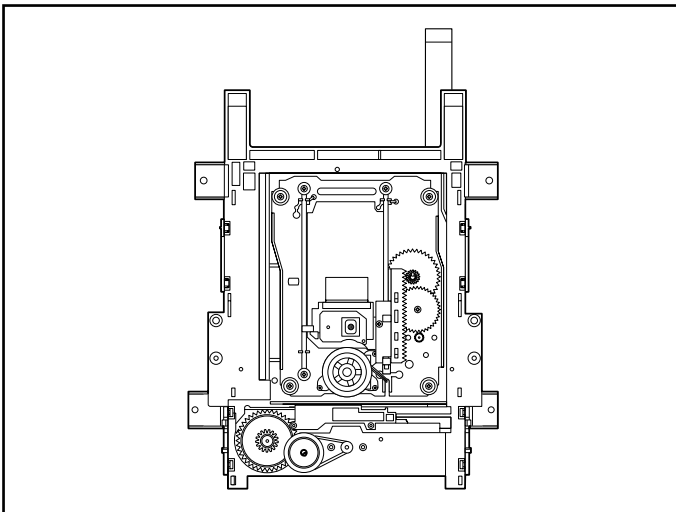

• Bottom View

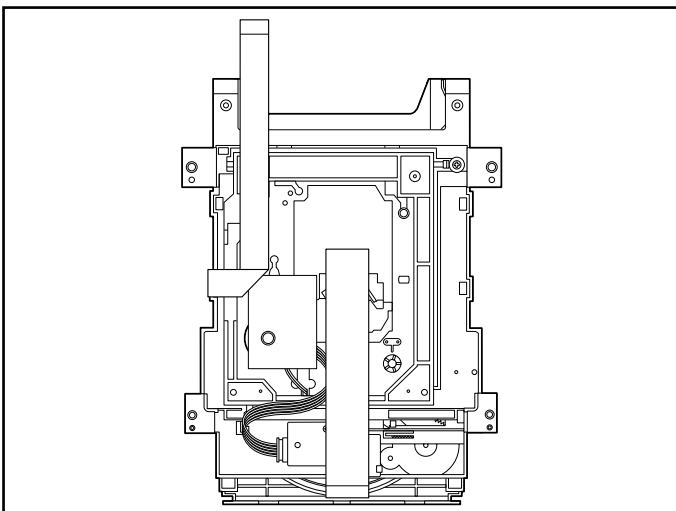

Procedure		Parts	Fixing Type	Disassembly	Figure
Starting No.					
	1	Holder Clamp	2 Screws, 2 Locking Tabs		4-1
1	2	Clamp Assembly Disc			4-1
1, 2	3	Plate Clamp			4-1
1, 2, 3	4	Magnet Clamp			4-1
1, 2, 3, 4	5	Clamp Upper			4-1
1	6	Tray Disc			4-2
1, 6	7	Base Assembly Sled	4 Screws,		4-3
1, 2, 6	8	Gear Assembly Feed			4-3
1, 2, 6, 8	9	Gear Middle			4-3
1, 2, 6, 8, 9	10	Gear Assembly Rack	1 Screw		4-3
1, 2, 7	11	Rubber Rear			4-3
1, 2, 7	12	Frame Assembly Up/Down	1 Screw	Bottom	4-4
1, 2	13	Belt Loading	1 Locking Tab		4-4
1, 2, 13	14	Gear Pulley			4-4
1, 2, 13, 14	15	Gear Loading	1 Locking Tab		4-4
1, 2, 7, 12, 13, 14	16	Guide Up/Down			4-4
1, 2, 13	17	PWB Assembly Loading	1 Locking Tab 1 Hook 2Screw	Bottom	4-4
1, 2, 7, 12, 13, 14, 15, 16, 17	18	Base Main			4-4

Note

When reassembling, perform the procedure in reverse order.

The "Bottom" on Disassembly column of above Table indicates the part should be disassembled at the Bottom side.

DECK MECHANISM DISASSEMBLY

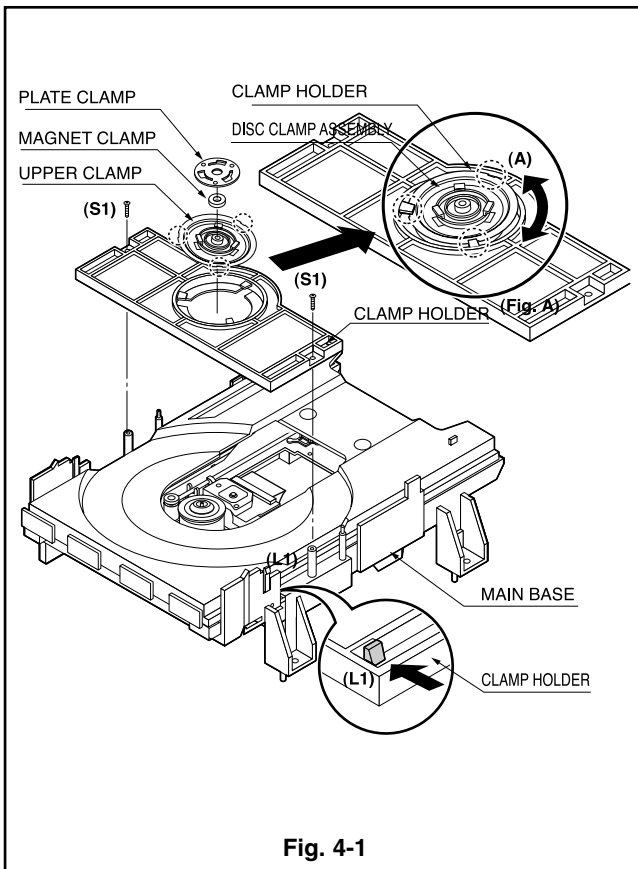

Fig. 4-1

1. Holder Clamp (Fig. 4-1)

- 1) Release 2 Screws(S1).
- 2) Unhook 2 Locking Tabs(L1).
- 3) Lift up the Holder Tabs and then separate it from the Base Main.

1-1. Clamp Assembly Disc

- 1) Place the Clamp Assembly Disc as Fig. (A)
- 2) Lift up the Clamp Assembly Disc in direction of arrow(A).
- 3) Separate the Clamp Assembly Disc from the Holder Clamp.

1-1-1. Plate Clamp

- 1) Turn the Plate Clamp to counterclockwise direction and then lift up the Plate Clamp.

1-1-2. Magnet Clamp

1-1-3. Clamp Upper

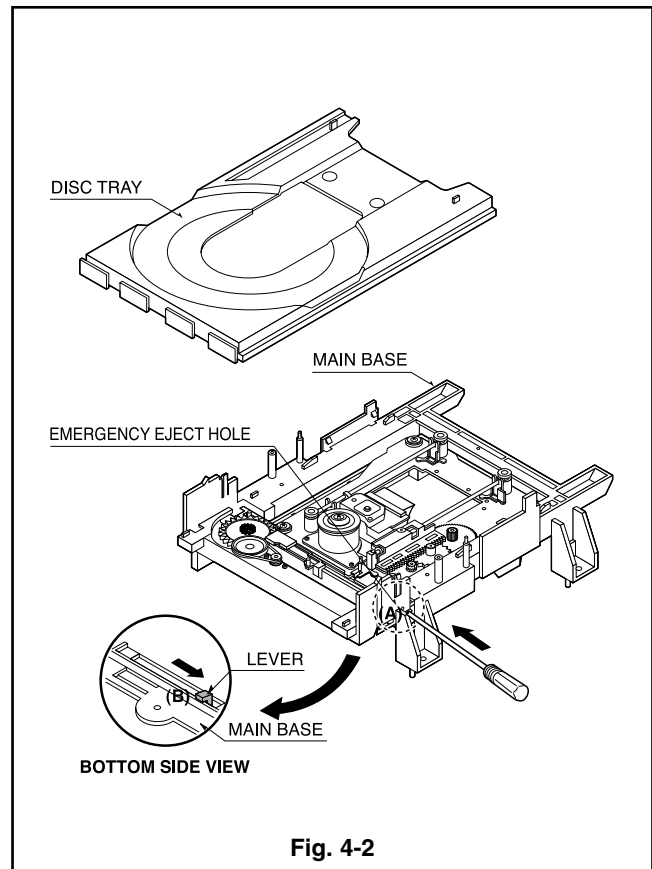

Fig. 4-2

2. Tray Disc (Fig. 4-2)

- 1) Insert and push a Driver in the emergency eject hole(A) at the right side, or put the Driver on the Lever(B) of the Gear Emergency and pull the Lever(B) in direction of arrow so that the Tray Disc is ejected about 15~20mm.
- 2) Pull the Tray Disc until it is separated from the Base Main completely.

DECK MECHANISM DISASSEMBLY

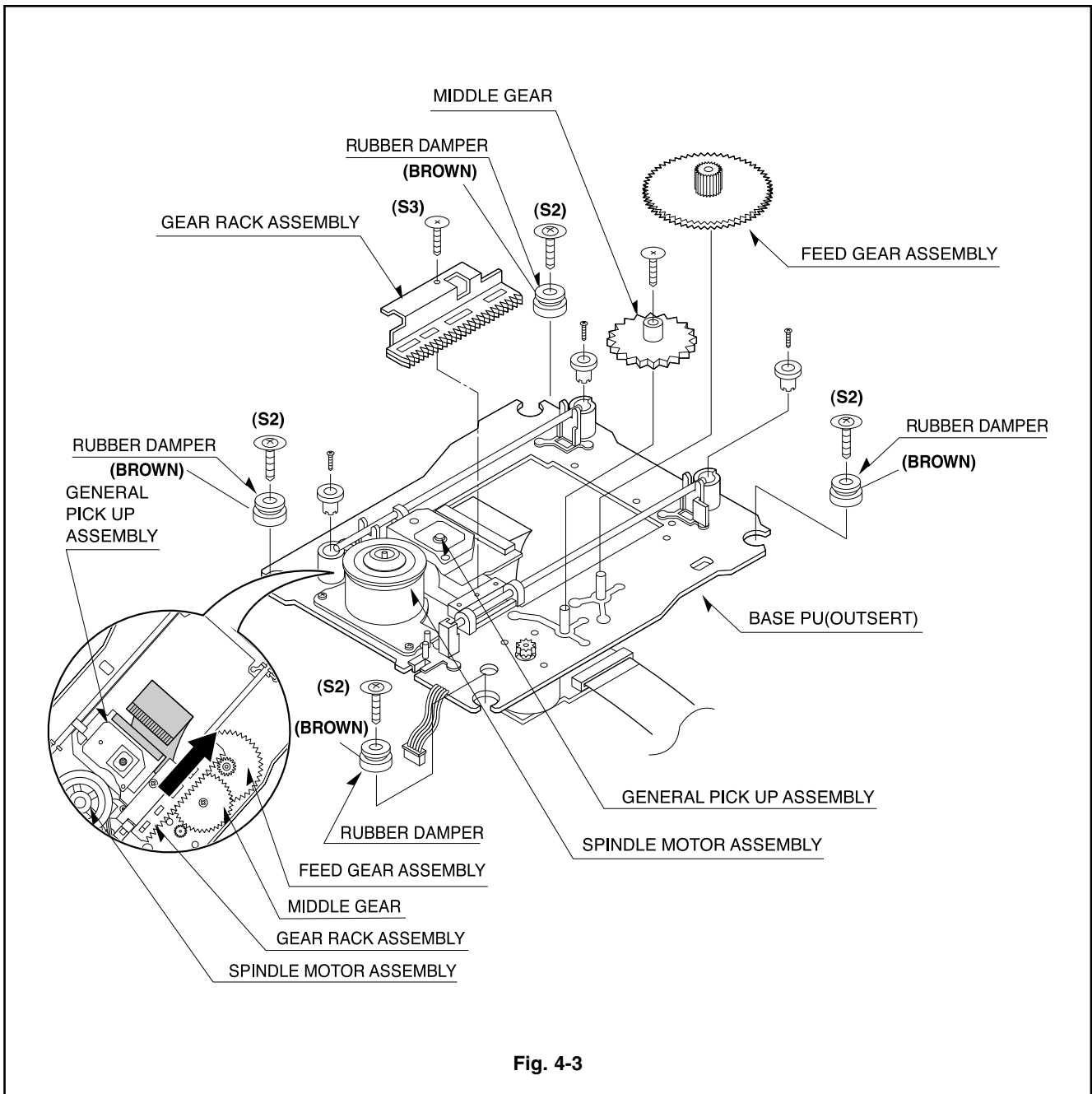

Fig. 4-3

3. Base Assembly Sled (Fig. 4-3)

- 1) Release 4 Screw(S2).
- 2) Disconnect the FFC Connector(C1)

3-1. Gear Assembly Feed

3-2. Gear Middle

3-3. Gear Assembly Rack

- 1) Release the Scerw(S3)

4. Rubber Rear (Fig. 4-3)

DECK MECHANISM DISASSEMBLY

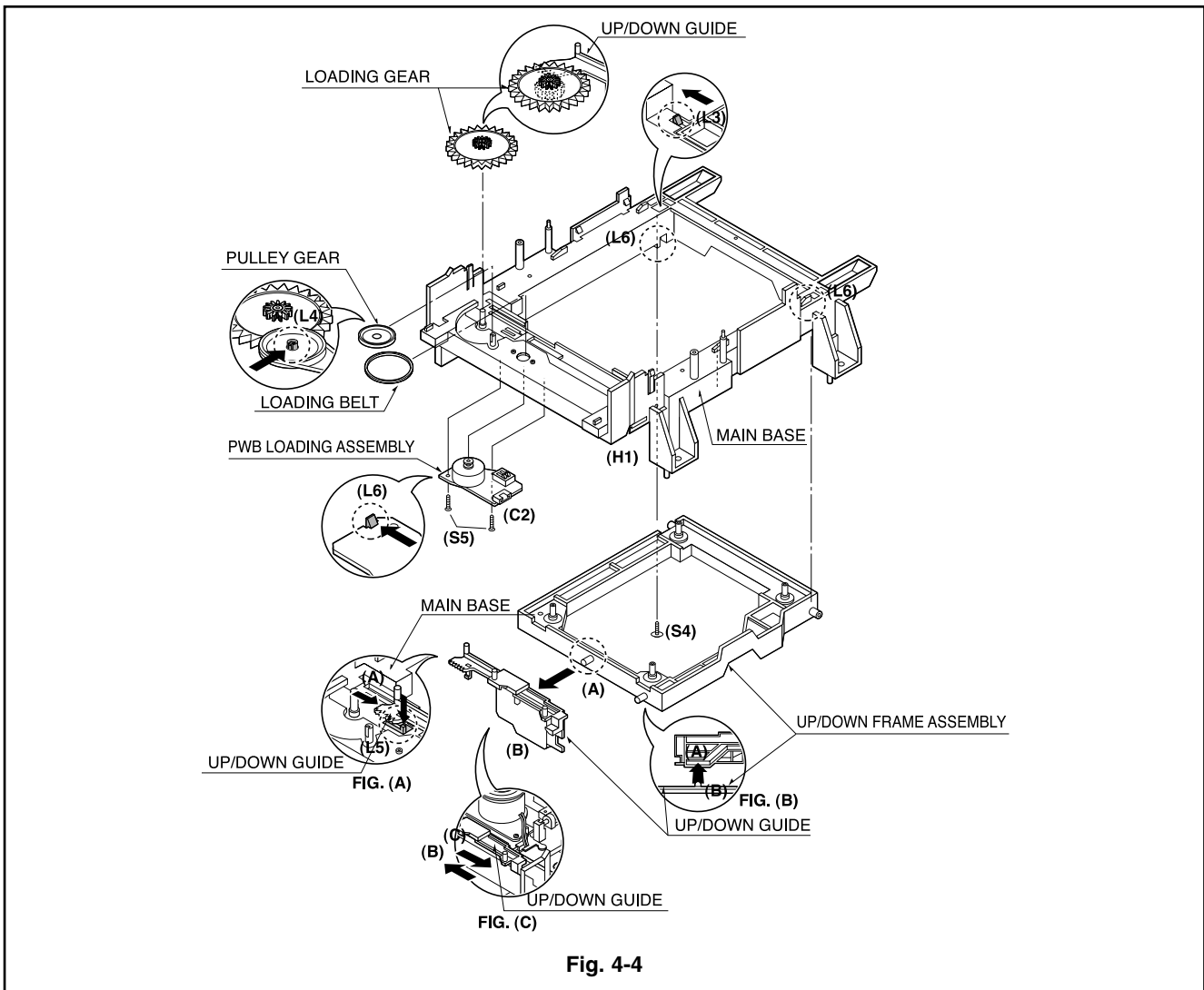

Fig. 4-4

5. Frame Assembly Up/Down (Fig. 4-4)

Note

Put the Base Main face down(Bottom Side)

- 1) Release the Screw(S4)
- 2) Unlock the Locking Tab(L3) in direction of arrow and then lift up the Frame Assembly Up/Down to separate it from the Base Main.

Note

- When reassembling move the Guide Up/Down in direction of arrow(C) until it is positioned as Fig.(C).
- When reassembling insert (A) portion of the Frame Assembly Up/Down in the (B) portion of the Guide Up/Down as Fig.(B)

6. Belt Loading(Fig. 4-4)

Note

Put the Base Main on original position(Top Side)

7. Gear pulley (Fig. 4-4)

- 1) Unlock the Locking Tab(L4) in direction of arrow(B) and then separate the Gear Pulley from the Base Main.

8. Gear Loading (Fig. 4-4)

9. Guide Up/Down (Fig. 4-4)

- 1) Move the Guide Up/Down in direction of arrow(A) as Fig.(A)
- 2) Push the Locking Tab(L5) down and then lift up the Guide Up/Down to separate it from the Base Main.

Note

When reassembling place the Guide Up/Down as Fig.(C) and move it in direction arrow(B) until it is locked by the Locking Tab(L5). And confirm the Guide Up/Down as Fig.(A)

10. PWB Assembly Loading (Fig. 4-4)

Note

Put the Base Main face down(Bottom Side)

- 1) Release 2 Screws(S5)
- 2) Unlock the Loading Motor (C2) from the Hook (H1) on the Base Main.
- 3) Unlock 2 Locking Tabs(L6) and separate the PWB Assembly Loading from the Base Main.

11. Base Main(Fig. 4-4)

MEMO

A series of horizontal dotted lines for writing.

EXPLODED VIEWS

1. Deck Mechanism Exploded View

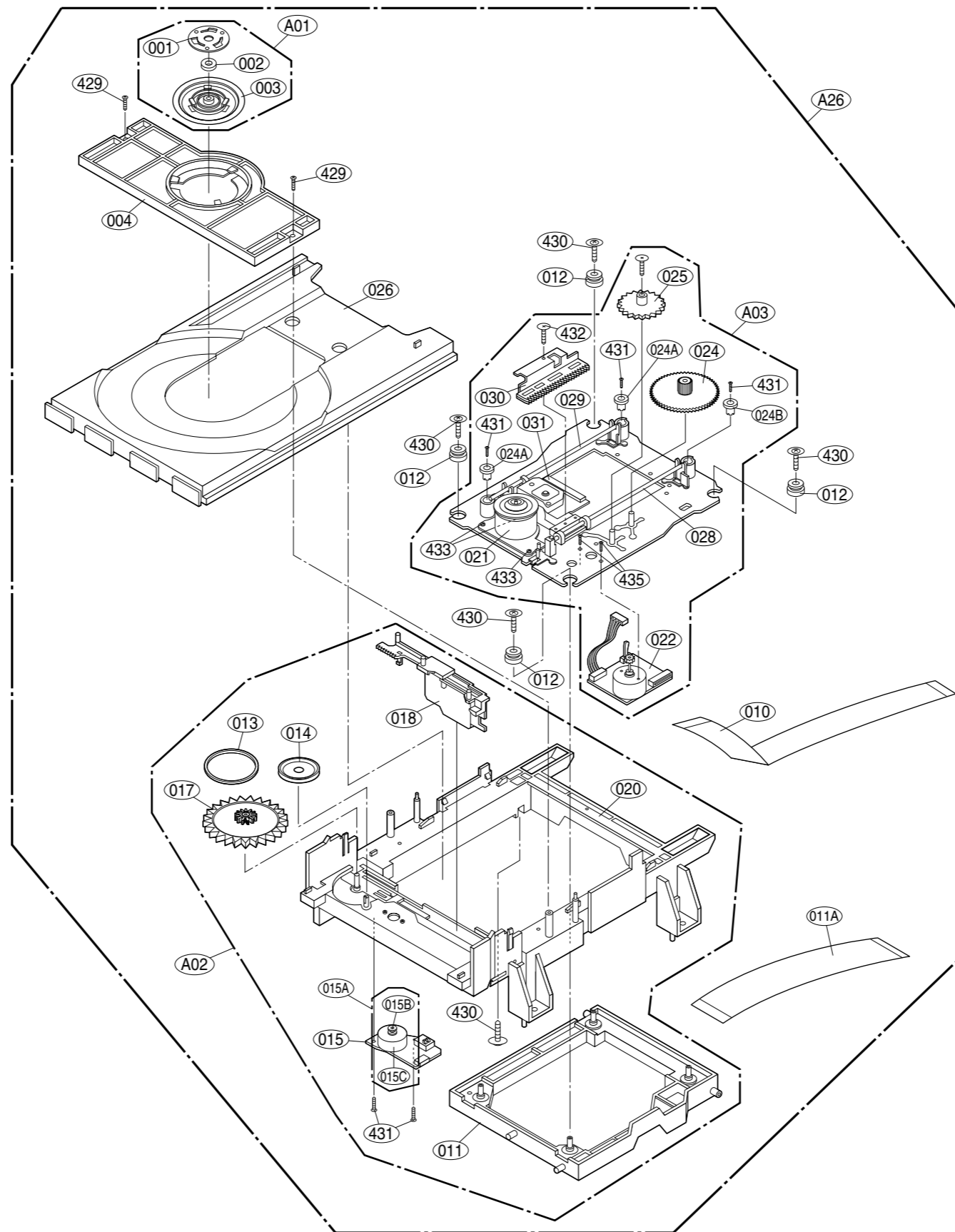

NOTES)  Warning
Parts that are shaded are critical
With respect to risk of fire or
electrical shock.

SECTION 5 REPLACEMENT PARTS LIST

MODELS:(A)DV7511E6S(DVD6054) (B)DV7811E6S(DVD6184)

RUN DATE:01.SEP.2003

.MECHANICAL SECTION

NSP:Not Service Part

S	AL	LOCA.NO	PART NO(LG)	A	B	DESCRIPTION	SPECIFICATION	REMARKS
ASSEMBLY PARTS SECTION								
		A00	6721RH0370A	O	O	DECK ASSEMBLY,VIDEO	DECK/MECHA DP-7(55) MITSUMI GO	NSP
		A01	4861R-0016B	O	O	CLAMP ASSEMBLY	DISC DP7 - SH	
		A02	3041R-M003B	O	O	BASE ASSEMBLY	MAIN(DP-7R) - SH	
		A03	3041R-M002B	O	O	BASE ASSEMBLY	SLED DP7(MIT 502W-GOLD) - SH	
PARTS SECTION								
		001	3300R-0547A	O	O	PLATE	CLAMP	NSP
		002	5016H-1016B	O	O	MAGNET	CLAMP(LDM-R608,10*5,1*1.5T)	NSP
		003	4860R-0021A	O	O	CLAMP	UPPER DP7	NSP
		004	4930R-0365A	O	O	HOLDER	CLAMP DP7	
		010	6850R-GF10B	O	O	CABLE,FLAT	P=1.0 FFC UL2896(0.05X0.65) 6	
		011	3210R-M001A	O	O	FRAME	UP/DOWN DP7 MOLD	
		011A	6850R-JW24Y	O	O	CABLE,FLAT	P=1.0 FFC UL2896(0.035X0.7) 23	
		012	5040R-0075D	O	O	RUBBER	DAMPER DP7 (YAMAUCHI 30)	
		013	4400H-1009A	O	O	BELT	GM-RT1332A	
		014	4470R-0055A	O	O	GEAR	PULLEY	
		015	6871R-9248B	O	O	PWB(PCB) ASSEMBLY,TOTAL	DP7 LOADING - SH	
		015A	4681R-A003B	O	O	MOTOR ASSEMBLY	LOADING DP7 - SH	
		015B	4560R-0008A	O	O	PULLEY	MOTOR	
		015C	4680R-E007A	O	O	MOTOR(MECH)	FEEDING BCZ3B01 SANKYO FOR DVD	
		017	4470R-0056A	O	O	GEAR	LOADING	
		018	4974R-0046A	O	O	GUIDE	UP/DOWN(DP-7)	
		020	3040R-M004A	O	O	BASE	MAIN(DP7-55MM) MOLD	NSP
		021	4680R-C010A	O	O	MOTOR(MECH)	SPINDLE JCL9B78 SANKYO FOR DVD	
		022	4681R-B005B	O	O	MOTOR ASSEMBLY	FEEDING DP7 - SH	
		022A	4680R-E008A	O	O	MOTOR(MECH)	FEEDING RF-300EA-1D390 MABUCHI	
		023	4470R-0119A	O	O	GEAR	FEED MOTOR	
		024	4470R-0124A	O	O	GEAR	PINION DP7	
		024A	5006R-0040A	O	O	CAP	SKEW (T) DP7	
		024B	5006R-0039A	O	O	CAP	SKEW (R) DP7	
		025	4470R-0122A	O	O	GEAR	MIDDLE A DP7	
		026	3390R-0015A	O	O	TRAY	DISC DP7	
		027	4470R-0123A	O	O	GEAR	MIDDLE B DP7	
		028	4370R-0083A	O	O	SHAFT	DECK/MECHA DP7 OTHER PU-T	
		029	4370R-0075A	O	O	SHAFT	PU	
		030	4471R-0010A	O	O	GEAR ASSEMBLY	RACK DP7	
		031	6716DPH005A	O	O	PICK UP,DVD	PVR-502W MITSUMI PLAYER H/HIGH	
		032	6871R-9243B	O	O	PWB(PCB) ASSEMBLY,TOTAL	DP7 FEEDING - SH	
SCREW								
		430	1SZZR-0046A	O	O	SCREW,DRAWING	+ 1 D2.0 L6.0 SWRCH16A/FZY	
		431	1SZZH-1007B	O	O	SCREW,DRAWING	+ D2.0 6MM SWRCH16A/ZNBK 4MM 1	
		433	1SZZR-0050A	O	O	SCREW,DRAWING	+ 1 D2.0 L4.5 SWRCH16A/ZNY S-T	
		434	1SZZR-0023B	O	O	SCREW,DRAWING	+ 1 D1.7 L6.0 SWRCH16A/FZY RAC	
		435	1SZZR-0011A	O	O	SCREW,	MACHINE	
		436	1SZZR-0047A	O	O	SCREW,DRAWING	+ 1 D1.4 L4.5 SWRCH16A/FZY TAP	

S	AL	LOCA.NO	PART NO(LG)	A	B	DESCRIPTION	SPECIFICATION	REMARKS
.CABINET & MAIN FRAME SECTION								
ASSEMBLY PARTS SECTION								
		A42	6871R-5725A	O		PWB(PCB) ASSEMBLY,TOTAL	DV7000S 5TOOL KEY SH	
		A42	6871R-5728A		O	PWB(PCB) ASSEMBLY,TOTAL	DV7000S 8TOOL KEY SH	
		A43	3501RF3007C		O	BOARD ASSEMBLY	DVD DV7811E4M HA3GLL	
		A43	3501RF6694F	O		BOARD ASSEMBLY	DVD DV7511E6L HA8PLL	
		A44	3141R-D003F	O		CHASSIS ASSEMBLY	DV7510E LSI,MTK 55MM	NSP
		A44	3141R-D004F		O	CHASSIS ASSEMBLY	DV7810E MTK 43MM	
		A46	6885R-1015D	O		SUB PWB(PCB) ASSEMBLY	DV7511E6S HA8PLL	
		A46	6885R-1015J		O	SUB PWB(PCB) ASSEMBLY	DV7811E6S HA8PLL	
		A47	6871R-7604C	O		PWB(PCB) ASSEMBLY,TOTAL	DV7000S SMPS SH 220V(CE)	
		A47	6871R-7604D		O	PWB(PCB) ASSEMBLY,TOTAL	DV7000S LSI SMPS SH 220V (CE)	
		A48	6871R-7601C	O	O	PWB(PCB) ASSEMBLY,TOTAL	DV7000S MTK SH SCART	
		A49	6871R-5715A	O		PWB(PCB) ASSEMBLY,TOTAL	DV7000S 5TOOL TIMER SH	
		A49	6871R-5718A		O	PWB(PCB) ASSEMBLY,TOTAL	DV7000S 8TOOL TIMER SH	
PARTS SECTION								
		250	3110R-D001A	O		CASE	DV7000 PRESS 430-55(A288G)	
		250	3110R-D004A		O	CASE	DV7000 PRESS 43MM A288G	
		260	3140R-D002A	O	O	CHASSIS	DV7000 PRESS MAIN	NSP
		261	5040R-0069D	O	O	RUBBER	FOOT(SILICONE SPONGE DS-08 T=	
		280	3721R-F306F	O		PANEL ASSEMBLY,FRONT[NORMAL PA	DV7511E6L HA8PLL	NSP
		280	3721R-F318C		O	PANEL ASSEMBLY,FRONT[NORMAL PA	DV7811E4M HA3GLL	NSP
		283	3581R-T068B	O		DOOR ASSEMBLY	TRAY DV7500 (CHINA)	
		283	3581R-T069A		O	DOOR ASSEMBLY	TRAY DV7800 (SPRAY)	
	⚠	300	6410RCHX03A	O	O	POWER CORD	CE-503/JL201B H03VVH2-F 2X0.75	
		320	3720R-D072F	O		PANEL,VIDEO	DVD DV7510E PRESS LSI,MTK 55MM	
		320	3720R-D074F		O	PANEL,VIDEO	DVD DV7810E PRESS MTK 43MM	
SCREW								
		452	353-051A	O		SCREW	SPECIAL	
		452	353-051A		O	SCREW	SPECIAL	
		463	353-051G	O	O	SCREW,DRAWING	+ 2 D3.0 L8.0 MSWR3/FN TB ROUN	
		465	353-046K	O	O	SCREW	SPECIAL (3X10 B.K)	
		467	353-046N	O	O	SCREW,DRAWING	SPECIAL(3X8 BK.)	
.PACKING & ACCESSORY SECTION								
		801	3835RS0063W	O		INSTRUCTION ASSEMBLY	DVD DV7511E6S HA8PLL	
		801	3835RS0064A		O	INSTRUCTION ASSEMBLY	DVD DV7811E6S HA8PLL	
		802	3890R-H803L	O	O	BOX	DV7511E6M HA8PLL SWW3-A 0.870	
		803	3920R-E066A	O	O	PACKING,CASING	DV7000 0.02 68 EPS 10 1165 238	
		804	292-053B	O	O	BAG	SOFT(MIDI)	NSP
		808	841-0021	O	O	BATTERY,MN	ER03X HI WATT 1.5V .MA/H AAA	
		810	6851RP0003N	O	O	CABLE ASSY,RF	DVD CABLE ASSY,RCA USING AREA	
		811	6611R1G001A	O	O	PLUG ASSY	1WAY YELLOW GLOBAL	
		812	6611R2G001A	O	O	PLUG ASSY	2WAY RED/WHITE GLOBAL	
.REMOTE CONTROL SECTION								
		900	6711R1P063A	O	O	REMOTE CONTROLLER ASSEMBLY	N6 UNIFIED DV7520E LG W/O DISC	

ELECTRICAL SECTION

S	AL	LOCA.NO	PART NO(LG)	A	B	DESCRIPTION	SPECIFICATION	REMARKS
		BC101	636-004C	O	O	FILTER(CIRC),EMC	BEAD CORE BFS3550R2FD8,R T/P	
		BD101	0DD160000DA	O	O	DIODE	S1WBA60(1A 600V) SHIDENKEN	
	⚠	C101	624-088S	O	O	CAPACITOR,DRAWING	MPX104K ETR/EUROPTRONIC BULK	
	⚠	C102	624-088S	O	O	CAPACITOR,DRAWING	MPX104K ETR/EUROPTRONIC BULK	
		C103	0CE686CU611	O		CAPACITOR,AL.ELECTROLYTIC	68UF SHL,SD 400V M FL BK7.5	
		C103	0CE686JU6A0		O	CAPACITOR,FIXED ELECTROLYTIC	68UF SMH,HC 400V 20% VNSN BULK	
		C104	624-085D	O	O	CAPACITOR	CE 47UF/50V KME (SMPS)	
		C106	0CE1064F638	O	O	CAPACITOR,ELECTROLYTIC	10M SRA 16V M FM5 TP(5)	
		C107	0CG2220U630	O	O	CAPACITOR,SEMI CERAMIC	2200 PF 400V M E R (NK,AD,SD)	
		C108	0CE4744K638	O	O	CAPACITOR,ELECTROLYTIC	0.47M SRA 50V M FM5 TP(5)	
		C109	0CE108BF630	O	O	CAPACITOR,FIXED ELECTROLYTIC	1000UF KME 16V M FM5 BULK	
		C110	0CN4730K948	O	O	CAPACITOR,FIXED TUBULAR(High d	0.047UF D 50V 80%,-20% F(Y5V)	
		C112	0CE3376D638	O	O	CAPACITOR,ELECTROLYTIC	330UF SMS 10V M FM5 TP5	
		C113	0CG1020U630	O	O	CAPACITOR,SEMI CERAMIC	1000PF 400V M E(Z5U) R	
		C115	0CE3366K638	O	O	CAPACITOR,FIXED ELECTROLYTIC	33UF SMS,SG 50V 20% FM5 TP 5	
		C116	0CE477BH630	O	O	CAPACITOR,AL.ELECTROLYTIC	470UF KME TYPE 25V M FM5 BULK	
		C118	0CE1074F638	O	O	CAPACITOR,ELECTROLYTIC	100U SRA 16V M FM5 TP(5)	
		C119	624-087G	O	O	CAPACITOR	HIGH-VOL 68PF/1KV SMPS SAMHWA	
		C120	0CE1074F638	O	O	CAPACITOR,ELECTROLYTIC	100U SRA 16V M FM5 TP(5)	
		C121	0CE2276F638	O	O	CAPACITOR,ELECTROLYTIC	220U SMS 16V M FM5 TP(5)	
		C122	624-085D	O	O	CAPACITOR	CE 47UF/50V KME (SMPS)	
		C123	0CE108BF630	O	O	CAPACITOR,FIXED ELECTROLYTIC	1000UF KME 16V M FM5 BULK	
		C124	0CE337CH618	O	O	CAPACITOR,FIXED ELECTROLYTIC	330UF SHL,SD 25V 20% FL TP 5	
		C126	0CQ1031Y519	O	O	CAPACITOR,POLYESTER	0.01UF D 630V K PE NI TP	
		C128	0CQ1042K409	O	O	CAPACITOR,FIXED FILM	0.1UF S 50V J PE TP	
		C129	0CE1074F638	O	O	CAPACITOR,ELECTROLYTIC	100U SRA 16V M FM5 TP(5)	
		C130	0CE1074F638	O	O	CAPACITOR,ELECTROLYTIC	100U SRA 16V M FM5 TP(5)	
		C131	0CE1074F638	O	O	CAPACITOR,ELECTROLYTIC	100U SRA 16V M FM5 TP(5)	
		C137	0CE3376D638	O	O	CAPACITOR,ELECTROLYTIC	330UF SMS 10V M FM5 TP5	
		C201	0CE1064F638	O	O	CAPACITOR,ELECTROLYTIC	10M SRA 16V M FM5 TP(5)	
		C202	0CE1064F638	O	O	CAPACITOR,ELECTROLYTIC	10M SRA 16V M FM5 TP(5)	
		C203	0CH1104K942	O	O	CAPACITOR,CHIP[CERAMIC M/L HD	0.1UF 50V Z Y5V(F) 1508 R/TP	
		C204	0CH1104K942	O	O	CAPACITOR,CHIP[CERAMIC M/L HD	0.1UF 50V Z Y5V(F) 1508 R/TP	
		C205	0CH1104K942	O	O	CAPACITOR,CHIP[CERAMIC M/L HD	0.1UF 50V Z Y5V(F) 1508 R/TP	
		C206	0CH1104K942	O	O	CAPACITOR,CHIP[CERAMIC M/L HD	0.1UF 50V Z Y5V(F) 1508 R/TP	
		C207	0CH1104K942	O	O	CAPACITOR,CHIP[CERAMIC M/L HD	0.1UF 50V Z Y5V(F) 1508 R/TP	
		C208	0CH1103K562	O	O	CAPACITOR,FIXED CERAMIC(Temp.c	0.01UF 50V 10% X7R(X) 1608 R/T	
		C209	0CE4764F638	O	O	CAPACITOR,ELECTROLYTIC	47M SRA/SS 16V M FM5 TP(5)	
		C210	0CH1103K562	O	O	CAPACITOR,FIXED CERAMIC(Temp.c	0.01UF 50V 10% X7R(X) 1608 R/T	
		C211	0CH1562K562	O	O	CAPACITOR,FIXED CERAMIC(Temp.c	5600PF 50V 10% X7R(X) 1608 R/T	
		C212	0CH1223K942	O	O	CAPACITOR,CHIP[CERAMIC M/L HD	0.022UF 50V Z Y5V(F) 1508 R/TP	
		C213	0CH1223K942	O	O	CAPACITOR,CHIP[CERAMIC M/L HD	0.022UF 50V Z Y5V(F) 1508 R/TP	
		C215	0CH1104K942	O	O	CAPACITOR,CHIP[CERAMIC M/L HD	0.1UF 50V Z Y5V(F) 1508 R/TP	
		C216	0CH1104K942	O	O	CAPACITOR,CHIP[CERAMIC M/L HD	0.1UF 50V Z Y5V(F) 1508 R/TP	
		C217	0CE1074F638	O	O	CAPACITOR,ELECTROLYTIC	100U SRA 16V M FM5 TP(5)	
		C218	0CE4764F638	O	O	CAPACITOR,ELECTROLYTIC	47M SRA/SS 16V M FM5 TP(5)	
		C219	0CH1103K562	O	O	CAPACITOR,FIXED CERAMIC(Temp.c	0.01UF 50V 10% X7R(X) 1608 R/T	
		C220	0CE4764F638	O	O	CAPACITOR,ELECTROLYTIC	47M SRA/SS 16V M FM5 TP(5)	
		C221	0CE1064F638	O	O	CAPACITOR,ELECTROLYTIC	10M SRA 16V M FM5 TP(5)	
		C222	0CH1105F942	O	O	CAPACITOR,FIXED CERAMIC(Temp.c	1000000PF 16V 80%,-20% Y5V(F)	
		C223	0CH1105F942	O	O	CAPACITOR,FIXED CERAMIC(Temp.c	1000000PF 16V 80%,-20% Y5V(F)	
		C224	0CH1103K562	O	O	CAPACITOR,FIXED CERAMIC(Temp.c	0.01UF 50V 10% X7R(X) 1608 R/T	
		C225	0CH1103K562	O	O	CAPACITOR,FIXED CERAMIC(Temp.c	0.01UF 50V 10% X7R(X) 1608 R/T	
		C226	0CH1103K562	O	O	CAPACITOR,FIXED CERAMIC(Temp.c	0.01UF 50V 10% X7R(X) 1608 R/T	
		C227	0CH1103K562	O	O	CAPACITOR,FIXED CERAMIC(Temp.c	0.01UF 50V 10% X7R(X) 1608 R/T	

S	AL	LOCA.NO	PART NO(LG)	A	B	DESCRIPTION	SPECIFICATION	REMARKS
		C228	0CH1103K562	O	O	CAPACITOR,FIXED CERAMIC(Temp.c	0.01UF 50V 10% X7R(X) 1608 R/T	
		C229	0CH1105F942	O	O	CAPACITOR,FIXED CERAMIC(Temp.c	1000000PF 16V 80%,-20% Y5V(F)	
		C230	0CH1105F942	O	O	CAPACITOR,FIXED CERAMIC(Temp.c	1000000PF 16V 80%,-20% Y5V(F)	
		C231	0CH1103K562	O	O	CAPACITOR,FIXED CERAMIC(Temp.c	0.01UF 50V 10% X7R(X) 1608 R/T	
		C232	0CH1103K562	O	O	CAPACITOR,FIXED CERAMIC(Temp.c	0.01UF 50V 10% X7R(X) 1608 R/T	
		C233	0CE4764F638	O	O	CAPACITOR,ELECTROLYTIC	47M SRA/SS 16V M FM5 TP(5)	
		C234	0CH1103K562	O	O	CAPACITOR,FIXED CERAMIC(Temp.c	0.01UF 50V 10% X7R(X) 1608 R/T	
		C235	0CH1103K562	O	O	CAPACITOR,FIXED CERAMIC(Temp.c	0.01UF 50V 10% X7R(X) 1608 R/T	
		C236	0CH1103K562	O	O	CAPACITOR,FIXED CERAMIC(Temp.c	0.01UF 50V 10% X7R(X) 1608 R/T	
		C237	0CH1103K562	O	O	CAPACITOR,FIXED CERAMIC(Temp.c	0.01UF 50V 10% X7R(X) 1608 R/T	
		C238	0CH1103K562	O	O	CAPACITOR,FIXED CERAMIC(Temp.c	0.01UF 50V 10% X7R(X) 1608 R/T	
		C239	0CH1103K562	O	O	CAPACITOR,FIXED CERAMIC(Temp.c	0.01UF 50V 10% X7R(X) 1608 R/T	
		C240	0CH1103K562	O	O	CAPACITOR,FIXED CERAMIC(Temp.c	0.01UF 50V 10% X7R(X) 1608 R/T	
		C241	0CH1103K562	O	O	CAPACITOR,FIXED CERAMIC(Temp.c	0.01UF 50V 10% X7R(X) 1608 R/T	
		C242	0CE4764F638	O	O	CAPACITOR,ELECTROLYTIC	47M SRA/SS 16V M FM5 TP(5)	
		C243	0CH1103K562	O	O	CAPACITOR,FIXED CERAMIC(Temp.c	0.01UF 50V 10% X7R(X) 1608 R/T	
		C244	0CH4120K412	O	O	CHIP CAPA CERAMIC M/L T.C F/S	12P 50V J COG 1.6X0.8 R/TP	
		C245	0CH4120K412	O	O	CHIP CAPA CERAMIC M/L T.C F/S	12P 50V J COG 1.6X0.8 R/TP	
		C246	0CH1102K562	O	O	CAPACITOR,FIXED CERAMIC(Temp.c	1000PF 50V 10% X7R(X) 1608 R/T	
		C247	0CH1102K562	O	O	CAPACITOR,FIXED CERAMIC(Temp.c	1000PF 50V 10% X7R(X) 1608 R/T	
		C248	0CH1102K562	O	O	CAPACITOR,FIXED CERAMIC(Temp.c	1000PF 50V 10% X7R(X) 1608 R/T	
		C249	0CH1102K562	O	O	CAPACITOR,FIXED CERAMIC(Temp.c	1000PF 50V 10% X7R(X) 1608 R/T	
		C250	0CH1104K942	O	O	CAPACITOR,CHIP[CERAMIC M/L HD	0.1UF 50V Z Y5V(F) 1508 R/TP	
		C251	0CE4764F638	O	O	CAPACITOR,ELECTROLYTIC	47M SRA/SS 16V M FM5 TP(5)	
		C252	0CE4764F638	O	O	CAPACITOR,ELECTROLYTIC	47M SRA/SS 16V M FM5 TP(5)	
		C253	0CH1104K942	O	O	CAPACITOR,CHIP[CERAMIC M/L HD	0.1UF 50V Z Y5V(F) 1508 R/TP	
		C254	0CH1104K942	O	O	CAPACITOR,CHIP[CERAMIC M/L HD	0.1UF 50V Z Y5V(F) 1508 R/TP	
		C255	0CE1064F638	O	O	CAPACITOR,ELECTROLYTIC	10M SRA 16V M FM5 TP(5)	
		C256	0CH1104K942	O	O	CAPACITOR,CHIP[CERAMIC M/L HD	0.1UF 50V Z Y5V(F) 1508 R/TP	
		C261	0CH1822K562	O	O	CAPACITOR,FIXED CERAMIC(Temp.c	8200PF 50V 10% X7R(X) 1608 R/T	
		C262	0CE4764F638	O	O	CAPACITOR,ELECTROLYTIC	47M SRA/SS 16V M FM5 TP(5)	
		C263	0CE4764F638	O	O	CAPACITOR,ELECTROLYTIC	47M SRA/SS 16V M FM5 TP(5)	
		C264	0CH1104K942	O	O	CAPACITOR,CHIP[CERAMIC M/L HD	0.1UF 50V Z Y5V(F) 1508 R/TP	
		C267	0CH4330K412	O	O	CAPACITOR,CHIP[CERAMIC M/L TC	33P 50V J COG 1.6X0.8 R/TP	
		C270	0CH1102K562	O	O	CAPACITOR,FIXED CERAMIC(Temp.c	1000PF 50V 10% X7R(X) 1608 R/T	
		C271	0CH4180K412	O	O	CAPACITOR,CHIP[CERAMIC M/L TC	18P 50V J COG 1.6X0.8 R/TP	
		C272	0CH4560K412	O	O	CAPA,CHIP CERAMIC M/L T.C F/S	56P 50V J COG 1.6X0.8 R/TP	
		C273	0CH4070K112	O	O	CAPACITOR,FIXED CERAMIC(High d	7PF 50V 0.5 pF NP0 1608 R/TP	
		C274	0CH1102K562	O	O	CAPACITOR,FIXED CERAMIC(Temp.c	1000PF 50V 10% X7R(X) 1608 R/T	
		C277	0CH1104K942	O	O	CAPACITOR,CHIP[CERAMIC M/L HD	0.1UF 50V Z Y5V(F) 1508 R/TP	
		C280	0CH1104K942	O	O	CAPACITOR,CHIP[CERAMIC M/L HD	0.1UF 50V Z Y5V(F) 1508 R/TP	
		C281	0CH1104K942	O	O	CAPACITOR,CHIP[CERAMIC M/L HD	0.1UF 50V Z Y5V(F) 1508 R/TP	
		C282	0CH1104K942	O	O	CAPACITOR,CHIP[CERAMIC M/L HD	0.1UF 50V Z Y5V(F) 1508 R/TP	
		C283	0CH1104K942	O	O	CAPACITOR,CHIP[CERAMIC M/L HD	0.1UF 50V Z Y5V(F) 1508 R/TP	
		C401	0CE4764F638	O	O	CAPACITOR,ELECTROLYTIC	47M SRA/SS 16V M FM5 TP(5)	
		C402	0CE1054K638	O	O	CAPACITOR,ELECTROLYTIC	1.0M SRA/SS50V M FM5 TP(5)	
		C403	0CE1054K638	O	O	CAPACITOR,ELECTROLYTIC	1.0M SRA/SS50V M FM5 TP(5)	
		C404	0CE1054K638	O	O	CAPACITOR,ELECTROLYTIC	1.0M SRA/SS50V M FM5 TP(5)	
		C405	0CE1054K638	O	O	CAPACITOR,ELECTROLYTIC	1.0M SRA/SS50V M FM5 TP(5)	
		C406	0CE1054K638	O	O	CAPACITOR,ELECTROLYTIC	1.0M SRA/SS50V M FM5 TP(5)	
		C407	0CE1054K638	O	O	CAPACITOR,ELECTROLYTIC	1.0M SRA/SS50V M FM5 TP(5)	
		C410	0CH1104K942	O	O	CAPACITOR,CHIP[CERAMIC M/L HD	0.1UF 50V Z Y5V(F) 1508 R/TP	
		C411	0CH1104K942	O	O	CAPACITOR,CHIP[CERAMIC M/L HD	0.1UF 50V Z Y5V(F) 1508 R/TP	
		C413	0CE4775C638	O	O	CAPACITOR,FIXED ELECTROLYTIC	470UF SR,SV 6.3V 20% FM5 TP 5	
		C414	0CE4775C638	O	O	CAPACITOR,FIXED ELECTROLYTIC	470UF SR,SV 6.3V 20% FM5 TP 5	
		C415	0CE4775C638	O	O	CAPACITOR,FIXED ELECTROLYTIC	470UF SR,SV 6.3V 20% FM5 TP 5	

S	AL	LOCA.NO	PART NO(LG)	A	B	DESCRIPTION	SPECIFICATION	REMARKS
		C416	0CE4775C638	O	O	CAPACITOR, FIXED ELECTROLYTIC	470UF SR, SV 6.3V 20% FM5 TP 5	
		C417	0CE4775C638	O	O	CAPACITOR, FIXED ELECTROLYTIC	470UF SR, SV 6.3V 20% FM5 TP 5	
		C418	0CE4775C638	O	O	CAPACITOR, FIXED ELECTROLYTIC	470UF SR, SV 6.3V 20% FM5 TP 5	
		C419	0CE1054K638	O	O	CAPACITOR, ELECTROLYTIC	1.0M SRA/SS50V M FM5 TP(5)	
		C420	0CE2264F638	O	O	CAPACITOR, ELECTROLYTIC	22M SRA 16V M FM5 TP(5)	
		C422	0CE4764F638	O	O	CAPACITOR, ELECTROLYTIC	47M SRA/SS 16V M FM5 TP(5)	
		C423	0CH1104K942	O	O	CAPACITOR, CHIP[CERAMIC M/L HD	0.1UF 50V Z Y5V(F) 1508 R/TP	
		C431	0CH1104K942	O	O	CAPACITOR, CHIP[CERAMIC M/L HD	0.1UF 50V Z Y5V(F) 1508 R/TP	
		C432	0CE4775C638	O	O	CAPACITOR, FIXED ELECTROLYTIC	470UF SR, SV 6.3V 20% FM5 TP 5	
		C434	0CE1064F638	O	O	CAPACITOR, ELECTROLYTIC	10M SRA 16V M FM5 TP(5)	
		C435	0CE2264F638	O	O	CAPACITOR, ELECTROLYTIC	22M SRA 16V M FM5 TP(5)	
		C436	0CH4101K412	O	O	CHIP CAPA CERAMIC M/L T.C F/S	100P 50V J COG 1.6X0.8 R/TP	
		C437	0CE2264F638	O	O	CAPACITOR, ELECTROLYTIC	22M SRA 16V M FM5 TP(5)	
		C438	0CH4101K412	O	O	CHIP CAPA CERAMIC M/L T.C F/S	100P 50V J COG 1.6X0.8 R/TP	
		C439	0CE2264F638	O	O	CAPACITOR, ELECTROLYTIC	22M SRA 16V M FM5 TP(5)	
		C440	0CH4101K412	O	O	CHIP CAPA CERAMIC M/L T.C F/S	100P 50V J COG 1.6X0.8 R/TP	
		C441	0CH4101K412	O	O	CHIP CAPA CERAMIC M/L T.C F/S	100P 50V J COG 1.6X0.8 R/TP	
		C442	0CE2264F638	O	O	CAPACITOR, ELECTROLYTIC	22M SRA 16V M FM5 TP(5)	
		C443	0CE2264F638	O	O	CAPACITOR, ELECTROLYTIC	22M SRA 16V M FM5 TP(5)	
		C444	0CH1392K562	O	O	CAPACITOR, FIXED CERAMIC(Temp.c	3900PF 50V K Z5U(E) 1608 R/TP	
		C445	0CH1392K562	O	O	CAPACITOR, FIXED CERAMIC(Temp.c	3900PF 50V K Z5U(E) 1608 R/TP	
		C446	0CE4764F638	O	O	CAPACITOR, ELECTROLYTIC	47M SRA/SS 16V M FM5 TP(5)	
		C447	0CH1104K942	O	O	CAPACITOR, CHIP[CERAMIC M/L HD	0.1UF 50V Z Y5V(F) 1508 R/TP	
		C448	0CH1104K942	O	O	CAPACITOR, CHIP[CERAMIC M/L HD	0.1UF 50V Z Y5V(F) 1508 R/TP	
		C449	0CH1104K942	O	O	CAPACITOR, CHIP[CERAMIC M/L HD	0.1UF 50V Z Y5V(F) 1508 R/TP	
		C450	0CH1104K942	O	O	CAPACITOR, CHIP[CERAMIC M/L HD	0.1UF 50V Z Y5V(F) 1508 R/TP	
		C451	0CH1104K942	O	O	CAPACITOR, CHIP[CERAMIC M/L HD	0.1UF 50V Z Y5V(F) 1508 R/TP	
		C452	0CH1104K942	O	O	CAPACITOR, CHIP[CERAMIC M/L HD	0.1UF 50V Z Y5V(F) 1508 R/TP	
		C453	0CH1104K942	O	O	CAPACITOR, CHIP[CERAMIC M/L HD	0.1UF 50V Z Y5V(F) 1508 R/TP	
		C454	0CH1104K942	O	O	CAPACITOR, CHIP[CERAMIC M/L HD	0.1UF 50V Z Y5V(F) 1508 R/TP	
		C501	0CH1104K942	O	O	CAPACITOR, CHIP[CERAMIC M/L HD	0.1UF 50V Z Y5V(F) 1508 R/TP	
		C502	0CH1104K942	O	O	CAPACITOR, CHIP[CERAMIC M/L HD	0.1UF 50V Z Y5V(F) 1508 R/TP	
		C503	0CH1104K942	O	O	CAPACITOR, CHIP[CERAMIC M/L HD	0.1UF 50V Z Y5V(F) 1508 R/TP	
		C504	0CH1104K942	O	O	CAPACITOR, CHIP[CERAMIC M/L HD	0.1UF 50V Z Y5V(F) 1508 R/TP	
		C505	0CH1104K942	O	O	CAPACITOR, CHIP[CERAMIC M/L HD	0.1UF 50V Z Y5V(F) 1508 R/TP	
		C506	0CH1104K942	O	O	CAPACITOR, CHIP[CERAMIC M/L HD	0.1UF 50V Z Y5V(F) 1508 R/TP	
		C507	0CH1104K942	O	O	CAPACITOR, CHIP[CERAMIC M/L HD	0.1UF 50V Z Y5V(F) 1508 R/TP	
		C508	0CH1104K942	O	O	CAPACITOR, CHIP[CERAMIC M/L HD	0.1UF 50V Z Y5V(F) 1508 R/TP	
		C509	0CH1104K942	O	O	CAPACITOR, CHIP[CERAMIC M/L HD	0.1UF 50V Z Y5V(F) 1508 R/TP	
		C510	0CH4270K412	O	O	CAPACITOR, CHIP[CERAMIC M/L TC	27PF 50V J NP0 1608 R/TP	
		C511	0CH4101K412	O	O	CHIP CAPA CERAMIC M/L T.C F/S	100P 50V J COG 1.6X0.8 R/TP	
		C512	0CH4101K412	O	O	CHIP CAPA CERAMIC M/L T.C F/S	100P 50V J COG 1.6X0.8 R/TP	
		C513	0CH1104K942	O	O	CAPACITOR, CHIP[CERAMIC M/L HD	0.1UF 50V Z Y5V(F) 1508 R/TP	
		C514	0CH1104K942	O	O	CAPACITOR, CHIP[CERAMIC M/L HD	0.1UF 50V Z Y5V(F) 1508 R/TP	
		C515	0CH1104K942	O	O	CAPACITOR, CHIP[CERAMIC M/L HD	0.1UF 50V Z Y5V(F) 1508 R/TP	
		C516	0CH1104K942	O	O	CAPACITOR, CHIP[CERAMIC M/L HD	0.1UF 50V Z Y5V(F) 1508 R/TP	
		C517	0CE4764F638	O	O	CAPACITOR, ELECTROLYTIC	47M SRA/SS 16V M FM5 TP(5)	
		C518	0CH1104K942	O	O	CAPACITOR, CHIP[CERAMIC M/L HD	0.1UF 50V Z Y5V(F) 1508 R/TP	
		C519	0CH1104K942	O	O	CAPACITOR, CHIP[CERAMIC M/L HD	0.1UF 50V Z Y5V(F) 1508 R/TP	
		C520	0CH1104K942	O	O	CAPACITOR, CHIP[CERAMIC M/L HD	0.1UF 50V Z Y5V(F) 1508 R/TP	
		C521	0CH1104K942	O	O	CAPACITOR, CHIP[CERAMIC M/L HD	0.1UF 50V Z Y5V(F) 1508 R/TP	
		C522	0CH1104K942	O	O	CAPACITOR, CHIP[CERAMIC M/L HD	0.1UF 50V Z Y5V(F) 1508 R/TP	
		C523	0CH1104K942	O	O	CAPACITOR, CHIP[CERAMIC M/L HD	0.1UF 50V Z Y5V(F) 1508 R/TP	
		C524	0CH1104K942	O	O	CAPACITOR, CHIP[CERAMIC M/L HD	0.1UF 50V Z Y5V(F) 1508 R/TP	
		C525	0CH1104K942	O	O	CAPACITOR, CHIP[CERAMIC M/L HD	0.1UF 50V Z Y5V(F) 1508 R/TP	
		C530	0CH1104K942	O	O	CAPACITOR, CHIP[CERAMIC M/L HD	0.1UF 50V Z Y5V(F) 1508 R/TP	

S	AL	LOCA.NO	PART NO(LG)	A	B	DESCRIPTION	SPECIFICATION	REMARKS
		C531	0CH1104K942	O	O	CAPACITOR,CHIP[CERAMIC M/L HD	0.1UF 50V Z Y5V(F) 1508 R/TP	
		C532	0CE4764F638	O	O	CAPACITOR,ELECTROLYTIC	47M SRA/SS 16V M FM5 TP(5)	
		C533	0CH1104K942	O	O	CAPACITOR,CHIP[CERAMIC M/L HD	0.1UF 50V Z Y5V(F) 1508 R/TP	
		C534	0CH1104K942	O	O	CAPACITOR,CHIP[CERAMIC M/L HD	0.1UF 50V Z Y5V(F) 1508 R/TP	
		C535	0CH1104K942	O	O	CAPACITOR,CHIP[CERAMIC M/L HD	0.1UF 50V Z Y5V(F) 1508 R/TP	
		C536	0CH1104K942	O	O	CAPACITOR,CHIP[CERAMIC M/L HD	0.1UF 50V Z Y5V(F) 1508 R/TP	
		C537	0CH1104K942	O	O	CAPACITOR,CHIP[CERAMIC M/L HD	0.1UF 50V Z Y5V(F) 1508 R/TP	
		C538	0CH1104K942	O	O	CAPACITOR,CHIP[CERAMIC M/L HD	0.1UF 50V Z Y5V(F) 1508 R/TP	
		C540	0CH1104K942	O	O	CAPACITOR,CHIP[CERAMIC M/L HD	0.1UF 50V Z Y5V(F) 1508 R/TP	
		C541	0CH4180K412	O	O	CAPACITOR,CHIP[CERAMIC M/L TC	18P 50V J COG 1.6X0.8 R/TP	
		C542	0CH4180K412	O	O	CAPACITOR,CHIP[CERAMIC M/L TC	18P 50V J COG 1.6X0.8 R/TP	
		C543	0CH1104K942	O	O	CAPACITOR,CHIP[CERAMIC M/L HD	0.1UF 50V Z Y5V(F) 1508 R/TP	
		C544	0CH4221K412	O	O	CAPACITOR,CHIP[CERAMIC M/L TC	220P 50V J COG 1.6X0.8 R/TP	
		C545	0CE4764F638	O	O	CAPACITOR,ELECTROLYTIC	47M SRA/SS 16V M FM5 TP(5)	
		C546	0CE4764F638	O	O	CAPACITOR,ELECTROLYTIC	47M SRA/SS 16V M FM5 TP(5)	
		C547	0CE4764F638	O	O	CAPACITOR,ELECTROLYTIC	47M SRA/SS 16V M FM5 TP(5)	
		C548	0CE4764F638	O	O	CAPACITOR,ELECTROLYTIC	47M SRA/SS 16V M FM5 TP(5)	
		C549	0CH1104K942	O	O	CAPACITOR,CHIP[CERAMIC M/L HD	0.1UF 50V Z Y5V(F) 1508 R/TP	
		C550	0CE4764F638	O	O	CAPACITOR,ELECTROLYTIC	47M SRA/SS 16V M FM5 TP(5)	
		C551	0CE1064F638	O	O	CAPACITOR,ELECTROLYTIC	10M SRA 16V M FM5 TP(5)	
		C553	0CH1104K942	O	O	CAPACITOR,CHIP[CERAMIC M/L HD	0.1UF 50V Z Y5V(F) 1508 R/TP	
		C554	0CH4221K412	O	O	CAPACITOR,CHIP[CERAMIC M/L TC	220P 50V J COG 1.6X0.8 R/TP	
		C555	0CH4221K412	O	O	CAPACITOR,CHIP[CERAMIC M/L TC	220P 50V J COG 1.6X0.8 R/TP	
		C556	0CH4221K412	O	O	CAPACITOR,CHIP[CERAMIC M/L TC	220P 50V J COG 1.6X0.8 R/TP	
		C557	0CH4221K412	O	O	CAPACITOR,CHIP[CERAMIC M/L TC	220P 50V J COG 1.6X0.8 R/TP	
		C558	0CH4330K412	O	O	CAPACITOR,CHIP[CERAMIC M/L TC	33P 50V J COG 1.6X0.8 R/TP	
		C559	0CH4330K412	O	O	CAPACITOR,CHIP[CERAMIC M/L TC	33P 50V J COG 1.6X0.8 R/TP	
		C560	0CH1104K942	O	O	CAPACITOR,CHIP[CERAMIC M/L HD	0.1UF 50V Z Y5V(F) 1508 R/TP	
		C561	0CH1104K942	O	O	CAPACITOR,CHIP[CERAMIC M/L HD	0.1UF 50V Z Y5V(F) 1508 R/TP	
		C562	0CH1104K942	O	O	CAPACITOR,CHIP[CERAMIC M/L HD	0.1UF 50V Z Y5V(F) 1508 R/TP	
		C563	0CH1104K942	O	O	CAPACITOR,CHIP[CERAMIC M/L HD	0.1UF 50V Z Y5V(F) 1508 R/TP	
		C651	0CE2274C638	O	O	CAPACITOR,ELECTROLYTIC	220M SRA 6.3V M FM5 TP(5)	
		C902	0CE1064F638	O	O	CAPACITOR,ELECTROLYTIC	10M SRA 16V M FM5 TP(5)	
		C906	0CH1104K942	O	O	CAPACITOR,CHIP[CERAMIC M/L HD	0.1UF 50V Z Y5V(F) 1508 R/TP	
		C907	0CH1104K942	O	O	CAPACITOR,CHIP[CERAMIC M/L HD	0.1UF 50V Z Y5V(F) 1508 R/TP	
		C908	0CE2274C638	O	O	CAPACITOR,ELECTROLYTIC	220M SRA 6.3V M FM5 TP(5)	
		C909	0CE4764J638	O		CAPACITOR,AL,ELECTROLYTIC	47UF SRA,SS 35V M FM5 TP 5	
		C909	0CH1104K942		O	CAPACITOR,CHIP[CERAMIC M/L HD	0.1UF 50V Z Y5V(F) 1508 R/TP	
		C910	0CH1104K942	O	O	CAPACITOR,CHIP[CERAMIC M/L HD	0.1UF 50V Z Y5V(F) 1508 R/TP	
		C911	0CH1104K942	O	O	CAPACITOR,CHIP[CERAMIC M/L HD	0.1UF 50V Z Y5V(F) 1508 R/TP	
		C912	0CE4764F638	O	O	CAPACITOR,ELECTROLYTIC	47M SRA/SS 16V M FM5 TP(5)	
		C913	0CH1104K942	O	O	CAPACITOR,CHIP[CERAMIC M/L HD	0.1UF 50V Z Y5V(F) 1508 R/TP	
		C9A1	0CH1104K942	O	O	CAPACITOR,CHIP[CERAMIC M/L HD	0.1UF 50V Z Y5V(F) 1508 R/TP	
		CN401	561-711O	O	O	CONNECTOR (CIRC),WAFER	GIL-S-15P-S2T2-EF LG CABLE 15P	
		CN402	6630XE00118	O	O	CONNECTOR (CIRC),FFC/FPC	04-6232-018-010-000/JE500-B1.0	
		CN505	6630XE00118	O	O	CONNECTOR (CIRC),FFC/FPC	04-6232-018-010-000/JE500-B1.0	
		CN601	6630R-FB05R	O	O	CONNECTOR (CIRC),FFC/FPC	00-6232-018-104-800 ELCO 18PIN	
		CN901	6630R-FB05R		O	CONNECTOR (CIRC),FFC/FPC	00-6232-018-104-800 ELCO 18PIN	
		CN901	6630R-FB10R	O		CONNECTOR (CIRC),FFC/FPC	00-6232-018-006-800 ELCO 18PIN	
		CN902	6631R-E034H		O	CONNECTOR ASSEMBLY	GIL-S/9073ST 4 PIN 100M/M UL10	
		CN902	6631R-E034H	O		CONNECTOR ASSEMBLY	GIL-S/9073ST 4 PIN 100M/M UL10	
		CN903	561-712D		O	CONNECTOR (CIRC),WAFER	GIL-S-04P-S2L2-EF LG CABLE 4PI	
		CN903	561-712D	O		CONNECTOR (CIRC),WAFER	GIL-S-04P-S2L2-EF LG CABLE 4PI	
		D100	0DD221009AA	O	O	DIODE,RECTIFIERS	ERA22-10 KFLB,TP ,R T/P,FUJI	
		D101	0DZ240009AF	O	O	DIODE,ZENERS	GDZJ24B GRANDE TP26 DO34 0.5W	
		D102	0DR158220AA	O	O	DIODE,RECTIFIER	1N5822 BK RECTRON DO201AD 40V	

S	AL	LOCA.NO	PART NO(LG)	A	B	DESCRIPTION	SPECIFICATION	REMARKS
		D103	0DR202000AB	O	O	DIODE,RECTIFIER	HER202 BK RECTRON NON 100V 2A	
		D104	0DR104009BA	O	O	DIODE,RECTIFIERS	RL104F TP RECTRON - 400V 1A 30	
		D105	874-000T	O	O	WIRE COPPER TIN COATED	D=0.6 ROLL	
		D106	0DR104009AB	O	O	DIODE,RECTIFIER	RL104 R. TP GULF SEMICONDUCTOR	
		D107	0DR104009BA	O	O	DIODE,RECTIFIERS	RL104F TP RECTRON - 400V 1A 30	
		D108	0DR104009BA	O	O	DIODE,RECTIFIERS	RL104F TP RECTRON - 400V 1A 30	
		D109	0DR202000AB	O	O	DIODE,RECTIFIER	HER202 BK RECTRON NON 100V 2A	
		D110	0DR104009BA	O	O	DIODE,RECTIFIERS	RL104F TP RECTRON - 400V 1A 30	
		D111	0DRRE00029A	O	O	DIODE,RECTIFIERS	1N17 RECTRON TP NON 20V 1A 20	
		D112	0DR158220AA	O	O	DIODE,RECTIFIER	1N5822 BK RECTRON DO201AD 40V	
		D401	0DSRM00118A	O	O	DIODE,SWITCHING	DAP202K T146 ROHM R/TP SMD 80V	
		DIG901	6302R-V205A		O	DIGITRON	HNV-06SC03T SS SDI SEG VFD DVD	
		DIG901	6302R-V205A	O		DIGITRON	HNV-06SC03T SS SDI SEG VFD DVD	
△		F101	0FS1601B51D	O	O	FUSE,SLOW BLOW	1600MA 250 V 5.2X20 CY/GL KS/J	
		F102	0RF0200F708	O	O	RESISTOR,VARIABLE[CARBON FILM]	0.2 OHM 1/6 W 10% TA26	
		F103	874-000T	O	O	WIRE COPPER TIN COATED	D=0.6 ROLL	
		F104	874-000T	O	O	WIRE COPPER TIN COATED	D=0.6 ROLL	
		F651	6200HJC901A	O	O	FILTER(CIRC),EMC	CFI06B1H101MF SAMHWA TP 2-5K	
		F652	6200HJC901A	O	O	FILTER(CIRC),EMC	CFI06B1H101MF SAMHWA TP 2-5K	
		F653	6200HJC901A	O	O	FILTER(CIRC),EMC	CFI06B1H101MF SAMHWA TP 2-5K	
		FH101	586-008B	O	O	HOLDER	FUSE CLIP TP SINSUNG	
		FH102	586-008B	O	O	HOLDER	FUSE CLIP TP SINSUNG	
		IC01	0IXL953615A	O	O	IC,XILINX	XC9536-15VQ44C 44P VQFP BK CPL	
△		IC101	0IPMGIH004A	O	O	IC,POWER MANAGEMENT	ICE2B0565 INFINEON 8PIN DIP ST	
△		IC102	657-063A	O	O	SENSOR	LTV-817B,PHOTO COUPLER(LITEON)	
		IC103	0IPMGFA017A	O	O	IC,POWER MANAGEMENT	KA78R12TSTU FAIRCHILD 4P TO-22	
		IC104	0IKE431000A	O	O	IC,KEC	KIA431 3 PIN TP	
		IC105	0IPMGFA016A	O	O	IC,POWER MANAGEMENT	KA78R08TSTU FAIRCHILD 4P TO-22	
		IC106	0IPMGFA015A	O	O	IC,POWER MANAGEMENT	KA78R33TSTU FAIRCHILD 4P TO-22	
		IC107	0IPMGFA015A	O	O	IC,POWER MANAGEMENT	KA78R33TSTU FAIRCHILD 4P TO-22	
		IC201	0IPRPSA010A	O	O	IC,PERIPHERALS	LA6560-A-TE-L SANYO HSOP-36R R	
		IC202	0ILNRSG010A	O	O	IC,LINEAR	STM6316-RAM SGS-THOMSON 100PIN	
		IC203	0IJR341400C	O	O	IC,JRC	NJM3414AM-TE1,3K/REEL. JRC -	
		IC204	0IPMGA7001A	O	O	IC,POWER MANAGEMENT	AMC1117-1.8SJ ADD MICROTTECH 3P	
		IC401	0IPRPBB006A	O	O	IC,PERIPHERALS	PCM1742KE BUR BROWN 16PIN SSOP	
		IC402	0IJR458000B	O	O	IC,JRC	NJM4580M 8,DMP8 TP OP AMP 2K/R	
		IC403	0IPRPMT008A	O	O	IC,PERIPHERALS	MM1623XFBE MITSUMI 28PIN SOP R	
		IC501	0ILNRSG011A	O	O	IC,LINEAR	STI5589 SGS-THOMSON 208PIN PQF	
		IC502	0IMMRH006A	O	O	IC,MEMORIES	IS42S16400A-7T INTEGRATED SILI	
		IC503	0IMMRHY040A	O	O	IC,MEMORIES	HY29LV160TT-70 HYNIX 48PIN TSO	
		IC504	0IFA742440F	O	O	IC,FAIRCHILD	MM74HCT244SJ 20P SOIC TP 3-STA	
		IC506	0ISTLTO015A	O	O	IC,STANDARD LOGIC	TC7WHU04FU TOSHIBA 8PIN SSOP R	
		IC508	0IPMGA7001A	O	O	IC,POWER MANAGEMENT	AMC1117-1.8SJ ADD MICROTTECH 3P	
		IC901	0IMCRHY070B	O	O	IC,MICRO CONTROLLER	HMS81C2012A-HK006 HYNIX 64PIN	
		IC902	0IKE704200B	O	O	IC,KEC	KIA7042P 3P 4.2V RESET(TAPING)	
		JK401	6612JH003LD	O	O	JACK,RCA	RCA-701A-02(SILVER) YUQIU	
		JK601	6612M00003A	O	O	JACK,SCART	RGB-21F(REV TYPE-SHIELD) BAE E	
△		L101	616-145M	O	O	FILTER(CIRC),DRAWING	V-04350 LS FUTAI BULK =616-145	
		L102	633-088D	O	O	COIL,CHOKE	CHOCK ,20UH KWANGSUNG LEAD CU	
		L103	633-088G	O	O	COIL,CHOKE	CHOCK(22MH) 5MM TOKO TP	
		L105	633-088G	O	O	COIL,CHOKE	CHOCK(22MH) 5MM TOKO TP	
		L201	0LR0102K035	O	O	INDUCTOR RADIAL LEAD	10M K 6X6 L5 TP	
		L202	0LR0102K035	O	O	INDUCTOR RADIAL LEAD	10M K 6X6 L5 TP	
		L203	6200HJC102A	O	O	FILTER(CIRC),EMC	HB-1M2012-102JT CERATECH TP	
		L204	6200HJC102A	O	O	FILTER(CIRC),EMC	HB-1M2012-102JT CERATECH TP	
		L205	6200HJC102A	O	O	FILTER(CIRC),EMC	HB-1M2012-102JT CERATECH TP	

S	AL	LOCA.NO	PART NO(LG)	A	B	DESCRIPTION	SPECIFICATION	REMARKS
		L206	6200HJC102A	O	O	FILTER(CIRC),EMC	HB-1M2012-102JT CERATECH TP	
		L207	6200HJC102A	O	O	FILTER(CIRC),EMC	HB-1M2012-102JT CERATECH TP	
		L208	6200HJC102A	O	O	FILTER(CIRC),EMC	HB-1M2012-102JT CERATECH TP	
		L209	6200HJC102A	O	O	FILTER(CIRC),EMC	HB-1M2012-102JT CERATECH TP	
		L210	0LR0221K035	O	O	INDUCTOR RADIAL LEAD	2.2M K 6X6 L5 TP	
		L211	0LR0102K035	O	O	INDUCTOR RADIAL LEAD	10M K 6X6 L5 TP	
		L401	6200HJC102A	O	O	FILTER(CIRC),EMC	HB-1M2012-102JT CERATECH TP	
		L402	6200HJC102A	O	O	FILTER(CIRC),EMC	HB-1M2012-102JT CERATECH TP	
		L403	6200HJC102A	O	O	FILTER(CIRC),EMC	HB-1M2012-102JT CERATECH TP	
		L405	6200HJC102A	O	O	FILTER(CIRC),EMC	HB-1M2012-102JT CERATECH TP	
		L406	6200HJC102A	O	O	FILTER(CIRC),EMC	HB-1M2012-102JT CERATECH TP	
		L407	6200HJC102A	O	O	FILTER(CIRC),EMC	HB-1M2012-102JT CERATECH TP	
		L408	6200HJC102A	O	O	FILTER(CIRC),EMC	HB-1M2012-102JT CERATECH TP	
		L501	6200HJC102A	O	O	FILTER(CIRC),EMC	HB-1M2012-102JT CERATECH TP	
		L502	6200HJC102A	O	O	FILTER(CIRC),EMC	HB-1M2012-102JT CERATECH TP	
		L503	6200HJC102A	O	O	FILTER(CIRC),EMC	HB-1M2012-102JT CERATECH TP	
		L504	6200HJC102A	O	O	FILTER(CIRC),EMC	HB-1M2012-102JT CERATECH TP	
		L505	6200HJC102A	O	O	FILTER(CIRC),EMC	HB-1M2012-102JT CERATECH TP	
		L506	6200HJC102A	O	O	FILTER(CIRC),EMC	HB-1M2012-102JT CERATECH TP	
		L507	0LCCE00005T	O	O	INDUCTOR,CHIP	HB-1S1608-400JT 400HM CERATECH	
		L508	6200JB8010V	O	O	FILTER(CIRC),EMC	LFA20-2A1E473MT MITSUBISHI MAT	
		L901	6200HJC102A	O	O	FILTER(CIRC),EMC	HB-1M2012-102JT CERATECH TP	
		L902	6200HJC102A	O	O	FILTER(CIRC),EMC	HB-1M2012-102JT CERATECH TP	
		LED01	0DL111209CA	O	O	LED	LTL-1CHEES-UA TP LITEON RED =0	
		LED02	0DL111209EA	O	O	LED	LTL-1CHKES-UA TP LITEON GREEN	
		LED03	0DL111209CA	O	O	LED	LTL-1CHEES-UA TP LITEON RED =0	
		LED901	0DL325319AA	O	O	LED	SPR325MVWT31 TP ROHM GREEN/RED	
		Q101	0TR534309BA	O	O	TRANSISTOR	2SC5343-L TP AUK TO92	
		Q102	0TR105009AD	O	O	TRANSISTOR,BIPOLARS	KRA105M KEC TP TO92 50V 100MA	
		Q107	0TR127309AA	O	O	TRANSISTOR	KTA1273-TP-Y (KTA966A)KEC	
		Q108	0TR534309BA	O	O	TRANSISTOR	2SC5343-L TP AUK TO92	
		Q202	0TR387509AC	O	O	TRANSISTOR	CHIP KTC3875S-GR-T1(ALG) KEC	
		Q203	0TR387509AC	O	O	TRANSISTOR	CHIP KTC3875S-GR-T1(ALG) KEC	
		Q204	0TR150409AC	O	O	TRANSISTOR	KTA1504-GR-T1(ASG) CHIP KEC	
		Q205	0TR150409AC	O	O	TRANSISTOR	KTA1504-GR-T1(ASG) CHIP KEC	
		Q206	0TR150409AC	O	O	TRANSISTOR	KTA1504-GR-T1(ASG) CHIP KEC	
		Q207	0TR387509AC	O	O	TRANSISTOR	CHIP KTC3875S-GR-T1(ALG) KEC	
		Q208	0TR387509AC	O	O	TRANSISTOR	CHIP KTC3875S-GR-T1(ALG) KEC	
		Q401	0TR150409AC	O	O	TRANSISTOR	KTA1504-GR-T1(ASG) CHIP KEC	
		Q402	0TR387509AC	O	O	TRANSISTOR	CHIP KTC3875S-GR-T1(ALG) KEC	
		Q404	0TR387509AC	O	O	TRANSISTOR	CHIP KTC3875S-GR-T1(ALG) KEC	
		Q405	0TR103009AC	O	O	TRANSISTOR	KRA103S-T1(PC)22-22 CHIP KEC	
		Q406	0TR103009AC	O	O	TRANSISTOR	KRA103S-T1(PC)22-22 CHIP KEC	
		Q407	0TR103009AC	O	O	TRANSISTOR	KRA103S-T1(PC)22-22 CHIP KEC	
		Q408	0TR103009AA	O	O	TRANSISTOR	CHIP KRC103S-T1(NC)22-22 KEC	
		Q651	0TR120309AE	O	O	TRANSISTOR	SRC1203 TP AUK TO92 22K,22K	
		Q901	0TR103009AA	O	O	TRANSISTOR	CHIP KRC103S-T1(NC)22-22 KEC	
		Q902	0TR103009AA	O	O	TRANSISTOR	CHIP KRC103S-T1(NC)22-22 KEC	
		R01	0RD3900F608	O	O	RESISTOR,FIXED CARBON FILM	390 OHM 1/6 W 5% TA26	
		R02	0RD3900F608	O	O	RESISTOR,FIXED CARBON FILM	390 OHM 1/6 W 5% TA26	
		R03	0RD3900F608	O	O	RESISTOR,FIXED CARBON FILM	390 OHM 1/6 W 5% TA26	
		R100	0RD1504H632	O	O	RESISTOR,FIXED CARBON FILM	1.5M OHM 1/2 W 5.00% MF10	
		R101	614-007A	O	O	RESISTOR	2.7/2W CEMENT SMPS V	
		R103	0RS5602K619	O	O	RESISTOR,FIXED METAL OXIDE FIL	56K OHM 2 W 5.00% TR	
		R107	0RS0600K619	O	O	RESISTOR,FIXED METAL OXIDE FIL	0.6 OHM 2 W 5% TR	
		R108	874-000T	O	O	WIRE COPPER TIN COATED	D=0.6 ROLL	

S	AL	LOCA.NO	PART NO(LG)	A	B	DESCRIPTION	SPECIFICATION	REMARKS
		R109	0RD2203F608	O	O	RESISTOR,FIXED CARBON FILM	220K OHM 1/6 W 5% TA26	
		R110	0RD2203F608	O	O	RESISTOR,FIXED CARBON FILM	220K OHM 1/6 W 5% TA26	
		R112	0RD0472F608	O	O	RESISTOR,FIXED CARBON FILM	47 OHM 1/6 W 5% TA26	
		R114	0RD1003F608	O	O	RESISTOR,FIXED CARBON FILM	100K OHM 1/6 W 5% TA26	
		R115	0RD0182F608	O	O	RESISTOR,FIXED CARBON FILM	18 OHM 1/6 W 5.00% TA26	
		R116	0RD0182F608	O	O	RESISTOR,FIXED CARBON FILM	18 OHM 1/6 W 5.00% TA26	
		R120	0RD4702F608	O	O	RESISTOR,FIXED CARBON FILM	47K OHM 1/6 W 5% TA26	
		R121	0RD1201F608	O	O	RESISTOR,FIXED CARBON FILM	1.2K OHM 1/6 W 5% TA26	
		R122	0RD2200F608	O	O	RESISTOR,FIXED CARBON FILM	220 OHM 1/6 W 5% TA26	
		R123	0RD1001F608	O	O	RESISTOR,FIXED CARBON FILM	1K OHM 1/6 W 5% TA26	
		R124	0RD1800F608	O	O	RESISTOR,FIXED CARBON FILM	180 OHM 1/6 W 5% TA26	
		R125	0RD3901F608	O	O	RESISTOR,FIXED CARBON FILM	3.9K OHM 1/6 W 5% TA26	
		R126	0RD1001F608	O	O	RESISTOR,FIXED CARBON FILM	1K OHM 1/6 W 5% TA26	
		R127	0RN3601E408	O	O	RESISTOR,FIXED METAL FILM	3.6K OHM 1/8 W 1.00% TA26	
		R128	0RN3301E408	O	O	RESISTOR,FIXED METAL FILM	3.3K OHM 1/8 W 1.00% TA26	
		R129	874-000T	O	O	WIRE COPPER TIN COATED	D=0.6 ROLL	
		R130	0RD1002F608	O	O	RESISTOR,FIXED CARBON FILM	10K OHM 1/6 W 5% TA26	
		R131	0RD2201F608	O	O	RESISTOR,FIXED CARBON FILM	2.2K OHM 1/6 W 5% TA26	
		R132	0RD1002F608	O	O	RESISTOR,FIXED CARBON FILM	10K OHM 1/6 W 5% TA26	
		R140	0RD1001F608	O	O	RESISTOR,FIXED CARBON FILM	1K OHM 1/6 W 5% TA26	
		R141	0RD1001F608	O	O	RESISTOR,FIXED CARBON FILM	1K OHM 1/6 W 5% TA26	
		R142	0RD1001F608	O	O	RESISTOR,FIXED CARBON FILM	1K OHM 1/6 W 5% TA26	
		R145	0RD4700F608	O	O	RESISTOR,FIXED CARBON FILM	470 OHM 1/6 W 5% TA26	
		R201	0RH0562C622	O	O	RESISTOR,METAL GLAZED(CHIP)	56 OHM 1 / 16 W 1608 5.00% D	
		R202	6200RJC003A	O	O	FILTER(CIRC),EMC	HB-1S1608-121 CERATECH TP	
		R203	6200RJC003A	O	O	FILTER(CIRC),EMC	HB-1S1608-121 CERATECH TP	
		R204	6200RJC003A	O	O	FILTER(CIRC),EMC	HB-1S1608-121 CERATECH TP	
		R205	0RH0562C622	O	O	RESISTOR,METAL GLAZED(CHIP)	56 OHM 1 / 16 W 1608 5.00% D	
		R206	0RH0562C622	O	O	RESISTOR,METAL GLAZED(CHIP)	56 OHM 1 / 16 W 1608 5.00% D	
		R207	0RH2200C622	O	O	RESISTOR,METAL GLAZED(CHIP)	220 OHM 1 / 16 W 1608 5.00% D	
		R208	0RH2200C622	O	O	RESISTOR,METAL GLAZED(CHIP)	220 OHM 1 / 16 W 1608 5.00% D	
		R209	0RH2200C622	O	O	RESISTOR,METAL GLAZED(CHIP)	220 OHM 1 / 16 W 1608 5.00% D	
		R210	0RH2200C622	O	O	RESISTOR,METAL GLAZED(CHIP)	220 OHM 1 / 16 W 1608 5.00% D	
		R211	0RH0000C622	O	O	RESISTOR,METAL GLAZED(CHIP)	0 OHM 1 / 16 W 1608 5.00% D	
		R213	0RH5601C622	O	O	RESISTOR,METAL GLAZED(CHIP)	5.6K OHM 1 / 16 W 1608 5.00% D	
		R214	0RH4700C422	O	O	RESISTOR,METAL GLAZED(CHIP)	470 OHM 1 / 16 W 1608 1.00% D	
		R215	0RH4700C422	O	O	RESISTOR,METAL GLAZED(CHIP)	470 OHM 1 / 16 W 1608 1.00% D	
		R216	0RH1802C422	O	O	RESISTOR,METAL GLAZED(CHIP)	18K OHM 1 / 16 W 1608 1.00% D	
		R217	0RH0000C622	O	O	RESISTOR,METAL GLAZED(CHIP)	0 OHM 1 / 16 W 1608 5.00% D	
		R218	0RH0221C622	O	O	RESISTOR,METAL GLAZED(CHIP)	2.2 OHM 1 / 16 W 1608 5.00% D	
		R219	0RH1002C622	O	O	RESISTOR,METAL GLAZED(CHIP)	10K OHM 1 / 16 W 1608 5.00% D	
		R220	0RH1002C622	O	O	RESISTOR,METAL GLAZED(CHIP)	10K OHM 1 / 16 W 1608 5.00% D	
		R221	0RH0221C622	O	O	RESISTOR,METAL GLAZED(CHIP)	2.2 OHM 1 / 16 W 1608 5.00% D	
		R222	0RH0221C622	O	O	RESISTOR,METAL GLAZED(CHIP)	2.2 OHM 1 / 16 W 1608 5.00% D	
		R223	0RH0221C622	O	O	RESISTOR,METAL GLAZED(CHIP)	2.2 OHM 1 / 16 W 1608 5.00% D	
		R224	0RH0101D622	O	O	RESISTOR,METAL GLAZED(CHIP)	1 OHM 1 / 10 W 2012 5.00% D	
		R225	0RH0221C622	O	O	RESISTOR,METAL GLAZED(CHIP)	2.2 OHM 1 / 16 W 1608 5.00% D	
		R226	0RH2201C622	O	O	RESISTOR,METAL GLAZED(CHIP)	2.2K OHM 1 / 16 W 1608 5.00% D	
		R228	0RH1004C622	O	O	RESISTOR,METAL GLAZED(CHIP)	1M OHM 1 / 16 W 1608 5.00% D	
		R229	0RH4702C622	O	O	RESISTOR,METAL GLAZED(CHIP)	47K OHM 1 / 16 W 1608 5.00% D	
		R230	0RH6801C622	O	O	RESISTOR,METAL GLAZED(CHIP)	6.8K OHM 1 / 16 W 1608 5.00% D	
		R231	0RH4701C622	O	O	RESISTOR,METAL GLAZED(CHIP)	4.7K OHM 1 / 16 W 1608 5.00% D	
		R232	0RH3901C622	O	O	RESISTOR,METAL GLAZED(CHIP)	3.9K OHM 1 / 16 W 1608 5.00% D	
		R233	0RH1502C622	O	O	RESISTOR,METAL GLAZED(CHIP)	15K OHM 1 / 16 W 1608 5.00% D	
		R235	0RH2002C422	O	O	RESISTOR,METAL GLAZED(CHIP)	20K OHM 1 / 16 W 1608 1.00% D	
		R236	0RH2701C422	O	O	RESISTOR,METAL GLAZED(CHIP)	2.7K OHM 1 / 16 W 1608 1.00% D	

S	AL	LOCA.NO	PART NO(LG)	A	B	DESCRIPTION	SPECIFICATION	REMARKS
		R237	0RH1004C622	O	O	RESISTOR,METAL GLAZED(CHIP)	1M OHM 1 / 16 W 1608 5.00% D	
		R245	0RH1002C622	O	O	RESISTOR,METAL GLAZED(CHIP)	10K OHM 1 / 16 W 1608 5.00% D	
		R246	0RH1002C622	O	O	RESISTOR,METAL GLAZED(CHIP)	10K OHM 1 / 16 W 1608 5.00% D	
		R248	0RH1002C622	O	O	RESISTOR,METAL GLAZED(CHIP)	10K OHM 1 / 16 W 1608 5.00% D	
		R249	0RH1002C622	O	O	RESISTOR,METAL GLAZED(CHIP)	10K OHM 1 / 16 W 1608 5.00% D	
		R250	0RH1002C622	O	O	RESISTOR,METAL GLAZED(CHIP)	10K OHM 1 / 16 W 1608 5.00% D	
		R252	0RH1002C422	O	O	RESISTOR,METAL GLAZED(CHIP)	10K OHM 1 / 16 W 1608 1.00% D	
		R253	0RH0000C622	O	O	RESISTOR,METAL GLAZED(CHIP)	0 OHM 1 / 16 W 1608 5.00% D	
		R254	0RH1802C422	O	O	RESISTOR,METAL GLAZED(CHIP)	18K OHM 1 / 16 W 1608 1.00% D	
		R255	0RH5601C622	O	O	RESISTOR,METAL GLAZED(CHIP)	5.6K OHM 1 / 16 W 1608 5.00% D	
		R256	0RH4700C422	O	O	RESISTOR,METAL GLAZED(CHIP)	470 OHM 1 / 16 W 1608 1.00% D	
		R257	0RH4700C422	O	O	RESISTOR,METAL GLAZED(CHIP)	470 OHM 1 / 16 W 1608 1.00% D	
		R258	0RH4700C422	O	O	RESISTOR,METAL GLAZED(CHIP)	470 OHM 1 / 16 W 1608 1.00% D	
		R259	0RH2201C622	O	O	RESISTOR,METAL GLAZED(CHIP)	2.2K OHM 1 / 16 W 1608 5.00% D	
		R261	0RH0000C622	O	O	RESISTOR,METAL GLAZED(CHIP)	0 OHM 1 / 16 W 1608 5.00% D	
		R262	0RH1802C422	O	O	RESISTOR,METAL GLAZED(CHIP)	18K OHM 1 / 16 W 1608 1.00% D	
		R263	0RH0000C622	O	O	RESISTOR,METAL GLAZED(CHIP)	0 OHM 1 / 16 W 1608 5.00% D	
		R264	0RH5601C622	O	O	RESISTOR,METAL GLAZED(CHIP)	5.6K OHM 1 / 16 W 1608 5.00% D	
		R265	0RH5601C622	O	O	RESISTOR,METAL GLAZED(CHIP)	5.6K OHM 1 / 16 W 1608 5.00% D	
		R266	0RH1802C422	O	O	RESISTOR,METAL GLAZED(CHIP)	18K OHM 1 / 16 W 1608 1.00% D	
		R267	0RH0000C622	O	O	RESISTOR,METAL GLAZED(CHIP)	0 OHM 1 / 16 W 1608 5.00% D	
		R268	0RH1201C622	O	O	RESISTOR,METAL GLAZED(CHIP)	1.2K OHM 1 / 16 W 1608 5.00% D	
		R269	0RH1201C622	O	O	RESISTOR,METAL GLAZED(CHIP)	1.2K OHM 1 / 16 W 1608 5.00% D	
		R271	0RH2200C622	O	O	RESISTOR,METAL GLAZED(CHIP)	220 OHM 1 / 16 W 1608 5.00% D	
		R272	0RH0272C622	O	O	RESISTOR,METAL GLAZED(CHIP)	27 OHM 1 / 16 W 1608 5.00% D	
		R273	0RH0272C622	O	O	RESISTOR,METAL GLAZED(CHIP)	27 OHM 1 / 16 W 1608 5.00% D	
		R274	0RH0000C622	O	O	RESISTOR,METAL GLAZED(CHIP)	0 OHM 1 / 16 W 1608 5.00% D	
		R275	0RH0000C622	O	O	RESISTOR,METAL GLAZED(CHIP)	0 OHM 1 / 16 W 1608 5.00% D	
		R276	0RH0000C622	O	O	RESISTOR,METAL GLAZED(CHIP)	0 OHM 1 / 16 W 1608 5.00% D	
		R277	0RH0000C622	O	O	RESISTOR,METAL GLAZED(CHIP)	0 OHM 1 / 16 W 1608 5.00% D	
		R278	0RH0472C622	O	O	RESISTOR,METAL GLAZED(CHIP)	47 OHM 1 / 16 W 1608 5.00% D	
		R279	0RH0472C622	O	O	RESISTOR,METAL GLAZED(CHIP)	47 OHM 1 / 16 W 1608 5.00% D	
		R280	0RH0272C622	O	O	RESISTOR,METAL GLAZED(CHIP)	27 OHM 1 / 16 W 1608 5.00% D	
		R281	0RH0272C622	O	O	RESISTOR,METAL GLAZED(CHIP)	27 OHM 1 / 16 W 1608 5.00% D	
		R282	0RH2200C622	O	O	RESISTOR,METAL GLAZED(CHIP)	220 OHM 1 / 16 W 1608 5.00% D	
		R283	0RH2200C622	O	O	RESISTOR,METAL GLAZED(CHIP)	220 OHM 1 / 16 W 1608 5.00% D	
		R286	0RH2700C622	O	O	RESISTOR,METAL GLAZED(CHIP)	270 OHM 1 / 16 W 1608 5.00% D	
		R287	0RH2700C622	O	O	RESISTOR,METAL GLAZED(CHIP)	270 OHM 1 / 16 W 1608 5.00% D	
		R288	0RH6801C622	O	O	RESISTOR,METAL GLAZED(CHIP)	6.8K OHM 1 / 16 W 1608 5.00% D	
		R289	0RH6801C622	O	O	RESISTOR,METAL GLAZED(CHIP)	6.8K OHM 1 / 16 W 1608 5.00% D	
		R291	0RH0000C622	O	O	RESISTOR,METAL GLAZED(CHIP)	0 OHM 1 / 16 W 1608 5.00% D	
		R292	0RH1002C622	O	O	RESISTOR,METAL GLAZED(CHIP)	10K OHM 1 / 16 W 1608 5.00% D	
		R293	0RH1002C622	O	O	RESISTOR,METAL GLAZED(CHIP)	10K OHM 1 / 16 W 1608 5.00% D	
		R294	0RH1002C622	O	O	RESISTOR,METAL GLAZED(CHIP)	10K OHM 1 / 16 W 1608 5.00% D	
		R296	0RH1003C622	O	O	RESISTOR,METAL GLAZED(CHIP)	100K OHM 1 / 16 W 1608 5.00% D	
		R297	0RH2201C622	O	O	RESISTOR,METAL GLAZED(CHIP)	2.2K OHM 1 / 16 W 1608 5.00% D	
		R298	0RH1201C622	O	O	RESISTOR,METAL GLAZED(CHIP)	1.2K OHM 1 / 16 W 1608 5.00% D	
		R2A1	0RH1002C622	O	O	RESISTOR,METAL GLAZED(CHIP)	10K OHM 1 / 16 W 1608 5.00% D	
		R2A2	0RH1005C622	O	O	RESISTOR,METAL GLAZED(CHIP)	1e+007 OHM 1 / 16 W 1608 5.00%	
		R2A3	0RH1005C622	O	O	RESISTOR,METAL GLAZED(CHIP)	1e+007 OHM 1 / 16 W 1608 5.00%	
		R2A5	0RH0912C622	O	O	RESISTOR,METAL GLAZED(CHIP)	91 OHM 1 / 16 W 1608 5.00% D	
		R2A6	0RH1001C622	O	O	RESISTOR,METAL GLAZED(CHIP)	1K OHM 1 / 16 W 1608 5.00% D	
		R2E1	0RH0912C622	O	O	RESISTOR,METAL GLAZED(CHIP)	91 OHM 1 / 16 W 1608 5.00% D	
		R2E2	0RH1002C622	O	O	RESISTOR,METAL GLAZED(CHIP)	10K OHM 1 / 16 W 1608 5.00% D	
		R2E4	0RH3901C622	O	O	RESISTOR,METAL GLAZED(CHIP)	3.9K OHM 1 / 16 W 1608 5.00% D	
		R2E5	0RH3901C622	O	O	RESISTOR,METAL GLAZED(CHIP)	3.9K OHM 1 / 16 W 1608 5.00% D	

S	AL	LOCA.NO	PART NO(LG)	A	B	DESCRIPTION	SPECIFICATION	REMARKS
		R2E8	0RH4701C622	O	O	RESISTOR,METAL GLAZED(CHIP)	4.7K OHM 1 / 16 W 1608 5.00% D	
		R2E9	0RH4701C622	O	O	RESISTOR,METAL GLAZED(CHIP)	4.7K OHM 1 / 16 W 1608 5.00% D	
		R2F1	0RH6800C622	O	O	RESISTOR,METAL GLAZED(CHIP)	680 OHM 1 / 16 W 1608 5.00% D	
		R2F2	0RH1001C622	O	O	RESISTOR,METAL GLAZED(CHIP)	1K OHM 1 / 16 W 1608 5.00% D	
		R2F3	0RH1000C622	O	O	RESISTOR,METAL GLAZED(CHIP)	100 OHM 1 / 16 W 1608 5.00% D	
		R2F4	0RH0000C622	O	O	RESISTOR,METAL GLAZED(CHIP)	0 OHM 1 / 16 W 1608 5.00% D	
		R2F5	0RH1003C622	O	O	RESISTOR,METAL GLAZED(CHIP)	100K OHM 1 / 16 W 1608 5.00% D	
		R2F6	0RH1003C622	O	O	RESISTOR,METAL GLAZED(CHIP)	100K OHM 1 / 16 W 1608 5.00% D	
		R2F7	0RH4700C422	O	O	RESISTOR,METAL GLAZED(CHIP)	470 OHM 1 / 16 W 1608 1.00% D	
		R402	0RH0000C622	O	O	RESISTOR,METAL GLAZED(CHIP)	0 OHM 1 / 16 W 1608 5.00% D	
		R403	0RH4700C622	O	O	RESISTOR,METAL GLAZED(CHIP)	470 OHM 1 / 16 W 1608 5.00% D	
		R404	0RH1001C622	O	O	RESISTOR,METAL GLAZED(CHIP)	1K OHM 1 / 16 W 1608 5.00% D	
		R405	0RH1001C622	O	O	RESISTOR,METAL GLAZED(CHIP)	1K OHM 1 / 16 W 1608 5.00% D	
		R406	0RH1001C622	O	O	RESISTOR,METAL GLAZED(CHIP)	1K OHM 1 / 16 W 1608 5.00% D	
		R407	0RH8201C622	O	O	RESISTOR,METAL GLAZED(CHIP)	8.2K OHM 1 / 16 W 1608 5.00% D	
		R408	0RH5601C622	O	O	RESISTOR,METAL GLAZED(CHIP)	5.6K OHM 1 / 16 W 1608 5.00% D	
		R409	0RH4701C622	O	O	RESISTOR,METAL GLAZED(CHIP)	4.7K OHM 1 / 16 W 1608 5.00% D	
		R410	0RH6801C622	O	O	RESISTOR,METAL GLAZED(CHIP)	6.8K OHM 1 / 16 W 1608 5.00% D	
		R411	0RH1001C622	O	O	RESISTOR,METAL GLAZED(CHIP)	1K OHM 1 / 16 W 1608 5.00% D	
		R412	0RH1502C622	O	O	RESISTOR,METAL GLAZED(CHIP)	15K OHM 1 / 16 W 1608 5.00% D	
		R413	0RH8201C622	O	O	RESISTOR,METAL GLAZED(CHIP)	8.2K OHM 1 / 16 W 1608 5.00% D	
		R414	0RH1502C622	O	O	RESISTOR,METAL GLAZED(CHIP)	15K OHM 1 / 16 W 1608 5.00% D	
		R415	0RH6801C622	O	O	RESISTOR,METAL GLAZED(CHIP)	6.8K OHM 1 / 16 W 1608 5.00% D	
		R416	0RH3300C622	O	O	RESISTOR,METAL GLAZED(CHIP)	330 OHM 1 / 16 W 1608 5.00% D	
		R417	0RH3300C622	O	O	RESISTOR,METAL GLAZED(CHIP)	330 OHM 1 / 16 W 1608 5.00% D	
		R418	0RH1001C622	O	O	RESISTOR,METAL GLAZED(CHIP)	1K OHM 1 / 16 W 1608 5.00% D	
		R419	0RH1001C622	O	O	RESISTOR,METAL GLAZED(CHIP)	1K OHM 1 / 16 W 1608 5.00% D	
		R420	0RH1001C622	O	O	RESISTOR,METAL GLAZED(CHIP)	1K OHM 1 / 16 W 1608 5.00% D	
		R421	0RH0752C622	O	O	RESISTOR,METAL GLAZED(CHIP)	75 OHM 1 / 16 W 1608 5.00% D	
		R422	0RH0752C622	O	O	RESISTOR,METAL GLAZED(CHIP)	75 OHM 1 / 16 W 1608 5.00% D	
		R423	0RH0752C622	O	O	RESISTOR,METAL GLAZED(CHIP)	75 OHM 1 / 16 W 1608 5.00% D	
		R424	0RH0752C622	O	O	RESISTOR,METAL GLAZED(CHIP)	75 OHM 1 / 16 W 1608 5.00% D	
		R425	0RH0752C622	O	O	RESISTOR,METAL GLAZED(CHIP)	75 OHM 1 / 16 W 1608 5.00% D	
		R426	0RH0752C622	O	O	RESISTOR,METAL GLAZED(CHIP)	75 OHM 1 / 16 W 1608 5.00% D	
		R427	0RH2200C622	O	O	RESISTOR,METAL GLAZED(CHIP)	220 OHM 1 / 16 W 1608 5.00% D	
		R428	0RH1003C622	O	O	RESISTOR,METAL GLAZED(CHIP)	100K OHM 1 / 16 W 1608 5.00% D	
		R429	0RH2200C622	O	O	RESISTOR,METAL GLAZED(CHIP)	220 OHM 1 / 16 W 1608 5.00% D	
		R430	0RH1003C622	O	O	RESISTOR,METAL GLAZED(CHIP)	100K OHM 1 / 16 W 1608 5.00% D	
		R431	0RH0000C622	O	O	RESISTOR,METAL GLAZED(CHIP)	0 OHM 1 / 16 W 1608 5.00% D	
		R435	0RH0102D622	O	O	RESISTOR,METAL GLAZED(CHIP)	10 OHM 1 / 10 W 2012 5.00% D	
		R436	0RH0222C622	O	O	RESISTOR,METAL GLAZED(CHIP)	22 OHM 1 / 16 W 1608 5.00% D	
		R437	0RH0102D622	O	O	RESISTOR,METAL GLAZED(CHIP)	10 OHM 1 / 10 W 2012 5.00% D	
		R440	0RH4701C622	O	O	RESISTOR,METAL GLAZED(CHIP)	4.7K OHM 1 / 16 W 1608 5.00% D	
		R441	0RH4701C622	O	O	RESISTOR,METAL GLAZED(CHIP)	4.7K OHM 1 / 16 W 1608 5.00% D	
		R500	0RH1004C622	O	O	RESISTOR,METAL GLAZED(CHIP)	1M OHM 1 / 16 W 1608 5.00% D	
		R501	0RH4701C622	O	O	RESISTOR,METAL GLAZED(CHIP)	4.7K OHM 1 / 16 W 1608 5.00% D	
		R504	0RH1000C422	O	O	RESISTOR,METAL GLAZED(CHIP)	100 OHM 1 / 16 W 1608 1.00% D	
		R505	0RH1000C422	O	O	RESISTOR,METAL GLAZED(CHIP)	100 OHM 1 / 16 W 1608 1.00% D	
		R506	0RH1000C422	O	O	RESISTOR,METAL GLAZED(CHIP)	100 OHM 1 / 16 W 1608 1.00% D	
		R507	0RH1000C422	O	O	RESISTOR,METAL GLAZED(CHIP)	100 OHM 1 / 16 W 1608 1.00% D	
		R508	0RH1000C422	O	O	RESISTOR,METAL GLAZED(CHIP)	100 OHM 1 / 16 W 1608 1.00% D	
		R509	0RH1000C422	O	O	RESISTOR,METAL GLAZED(CHIP)	100 OHM 1 / 16 W 1608 1.00% D	
		R510	0RH1002C422	O	O	RESISTOR,METAL GLAZED(CHIP)	10K OHM 1 / 16 W 1608 1.00% D	
		R511	0RH1002C422	O	O	RESISTOR,METAL GLAZED(CHIP)	10K OHM 1 / 16 W 1608 1.00% D	
		R513	0RH0332C622	O	O	RESISTOR,METAL GLAZED(CHIP)	33 OHM 1 / 16 W 1608 5.00% D	
		R514	0RH4701C622	O	O	RESISTOR,METAL GLAZED(CHIP)	4.7K OHM 1 / 16 W 1608 5.00% D	

S	AL	LOCA.NO	PART NO(LG)	A	B	DESCRIPTION	SPECIFICATION	REMARKS
		R515	0RH0222C622	O	O	RESISTOR,METAL GLAZED(CHIP)	22 OHM 1 / 16 W 1608 5.00% D	
		R516	0RH1100C622	O	O	RESISTOR,METAL GLAZED(CHIP)	110 OHM 1 / 16 W 1608 5.00% D	
		R517	0RH0752C622	O	O	RESISTOR,METAL GLAZED(CHIP)	75 OHM 1 / 16 W 1608 5.00% D	
		R518	0RH1100C622	O	O	RESISTOR,METAL GLAZED(CHIP)	110 OHM 1 / 16 W 1608 5.00% D	
		R519	0RH0472C622	O	O	RESISTOR,METAL GLAZED(CHIP)	47 OHM 1 / 16 W 1608 5.00% D	
		R520	0RH0472C622	O	O	RESISTOR,METAL GLAZED(CHIP)	47 OHM 1 / 16 W 1608 5.00% D	
		R533	0RH0000C622	O	O	RESISTOR,METAL GLAZED(CHIP)	0 OHM 1 / 16 W 1608 5.00% D	
		R534	0RH0000C622	O	O	RESISTOR,METAL GLAZED(CHIP)	0 OHM 1 / 16 W 1608 5.00% D	
		R535	0RH0472C622	O	O	RESISTOR,METAL GLAZED(CHIP)	47 OHM 1 / 16 W 1608 5.00% D	
		R536	0RH0472C622	O	O	RESISTOR,METAL GLAZED(CHIP)	47 OHM 1 / 16 W 1608 5.00% D	
		R537	0RH0472C622	O	O	RESISTOR,METAL GLAZED(CHIP)	47 OHM 1 / 16 W 1608 5.00% D	
		R538	0RH0472C622	O	O	RESISTOR,METAL GLAZED(CHIP)	47 OHM 1 / 16 W 1608 5.00% D	
		R539	0RH0472C622	O	O	RESISTOR,METAL GLAZED(CHIP)	47 OHM 1 / 16 W 1608 5.00% D	
		R540	0RH0472C622	O	O	RESISTOR,METAL GLAZED(CHIP)	47 OHM 1 / 16 W 1608 5.00% D	
		R558	0RH0472C622	O	O	RESISTOR,METAL GLAZED(CHIP)	47 OHM 1 / 16 W 1608 5.00% D	
		R559	0RH0472C622	O	O	RESISTOR,METAL GLAZED(CHIP)	47 OHM 1 / 16 W 1608 5.00% D	
		R560	0RH0472C622	O	O	RESISTOR,METAL GLAZED(CHIP)	47 OHM 1 / 16 W 1608 5.00% D	
		R561	0RH1002C622	O	O	RESISTOR,METAL GLAZED(CHIP)	10K OHM 1 / 16 W 1608 5.00% D	
		R562	0RH1002C622	O	O	RESISTOR,METAL GLAZED(CHIP)	10K OHM 1 / 16 W 1608 5.00% D	
		R563	0RH1002C622	O	O	RESISTOR,METAL GLAZED(CHIP)	10K OHM 1 / 16 W 1608 5.00% D	
		R564	0RH0752C622	O	O	RESISTOR,METAL GLAZED(CHIP)	75 OHM 1 / 16 W 1608 5.00% D	
		R565	0RH0752C622	O	O	RESISTOR,METAL GLAZED(CHIP)	75 OHM 1 / 16 W 1608 5.00% D	
		R566	0RH0752C622	O	O	RESISTOR,METAL GLAZED(CHIP)	75 OHM 1 / 16 W 1608 5.00% D	
		R567	0RH0752C622	O	O	RESISTOR,METAL GLAZED(CHIP)	75 OHM 1 / 16 W 1608 5.00% D	
		R568	0RH0752C622	O	O	RESISTOR,METAL GLAZED(CHIP)	75 OHM 1 / 16 W 1608 5.00% D	
		R569	0RH0752C622	O	O	RESISTOR,METAL GLAZED(CHIP)	75 OHM 1 / 16 W 1608 5.00% D	
		R570	0RH1002C622	O	O	RESISTOR,METAL GLAZED(CHIP)	10K OHM 1 / 16 W 1608 5.00% D	
		R599	0RH1002C622	O	O	RESISTOR,METAL GLAZED(CHIP)	10K OHM 1 / 16 W 1608 5.00% D	
		R5A5	0RH4702C622	O	O	RESISTOR,METAL GLAZED(CHIP)	47K OHM 1 / 16 W 1608 5.00% D	
		R5A6	0RH1000C622	O	O	RESISTOR,METAL GLAZED(CHIP)	100 OHM 1 / 16 W 1608 5.00% D	
		R5A7	0RH1002C622	O	O	RESISTOR,METAL GLAZED(CHIP)	10K OHM 1 / 16 W 1608 5.00% D	
		R5A8	0RH0000C622	O	O	RESISTOR,METAL GLAZED(CHIP)	0 OHM 1 / 16 W 1608 5.00% D	
		R5A9	0RH1002C622	O	O	RESISTOR,METAL GLAZED(CHIP)	10K OHM 1 / 16 W 1608 5.00% D	
		R5B1	0RH1002C622	O	O	RESISTOR,METAL GLAZED(CHIP)	10K OHM 1 / 16 W 1608 5.00% D	
		R5B2	0RH1002C622	O	O	RESISTOR,METAL GLAZED(CHIP)	10K OHM 1 / 16 W 1608 5.00% D	
		R5B3	0RH1002C622	O	O	RESISTOR,METAL GLAZED(CHIP)	10K OHM 1 / 16 W 1608 5.00% D	
		R5B4	0RH1002C622	O	O	RESISTOR,METAL GLAZED(CHIP)	10K OHM 1 / 16 W 1608 5.00% D	
		R5B6	0RH1002C622	O	O	RESISTOR,METAL GLAZED(CHIP)	10K OHM 1 / 16 W 1608 5.00% D	
		R5B7	0RH0472C622	O	O	RESISTOR,METAL GLAZED(CHIP)	47 OHM 1 / 16 W 1608 5.00% D	
		R5C1	0RH1000C622	O	O	RESISTOR,METAL GLAZED(CHIP)	100 OHM 1 / 16 W 1608 5.00% D	
		R5C2	0RH1000C622	O	O	RESISTOR,METAL GLAZED(CHIP)	100 OHM 1 / 16 W 1608 5.00% D	
		R5C3	0RH1000C622	O	O	RESISTOR,METAL GLAZED(CHIP)	100 OHM 1 / 16 W 1608 5.00% D	
		R5C4	0RH1000C622	O	O	RESISTOR,METAL GLAZED(CHIP)	100 OHM 1 / 16 W 1608 5.00% D	
		R5C5	0RH1002C622	O	O	RESISTOR,METAL GLAZED(CHIP)	10K OHM 1 / 16 W 1608 5.00% D	
		R651	0RD0752F608	O	O	RESISTOR,FIXED CARBON FILM	75 OHM 1/6 W 5.00% TA26	
		R652	0RD4700F608	O	O	RESISTOR,FIXED CARBON FILM	470 OHM 1/6 W 5% TA26	
		R653	0RD1003F608	O	O	RESISTOR,FIXED CARBON FILM	100K OHM 1/6 W 5% TA26	
		R654	0RD4700F608	O	O	RESISTOR,FIXED CARBON FILM	470 OHM 1/6 W 5% TA26	
		R655	0RD0752F608	O	O	RESISTOR,FIXED CARBON FILM	75 OHM 1/6 W 5.00% TA26	
		R656	0RD1003F608	O	O	RESISTOR,FIXED CARBON FILM	100K OHM 1/6 W 5% TA26	
		R657	0RD2200F608	O	O	RESISTOR,FIXED CARBON FILM	220 OHM 1/6 W 5% TA26	
		R658	0RD1003F608	O	O	RESISTOR,FIXED CARBON FILM	100K OHM 1/6 W 5% TA26	
		R659	0RD2200F608	O	O	RESISTOR,FIXED CARBON FILM	220 OHM 1/6 W 5% TA26	
		R901	0RH6800C622	O	O	RESISTOR,METAL GLAZED(CHIP)	680 OHM 1 / 16 W 1608 5.00% D	
		R902	0RH8200C622	O	O	RESISTOR,METAL GLAZED(CHIP)	820 OHM 1 / 16 W 1608 5.00% D	
		R903	0RH1201C622	O	O	RESISTOR,METAL GLAZED(CHIP)	1.2K OHM 1 / 16 W 1608 5.00% D	

S	AL	LOCA.NO	PART NO(LG)	A	B	DESCRIPTION	SPECIFICATION	REMARKS
		R904	0RH1501C622	O	O	RESISTOR,METAL GLAZED(CHIP)	1.5K OHM 1 / 16 W 1608 5.00% D	
		R905	0RH2201C622	O	O	RESISTOR,METAL GLAZED(CHIP)	2.2K OHM 1 / 16 W 1608 5.00% D	
		R906	0RH3301C622	O	O	RESISTOR,METAL GLAZED(CHIP)	3.3K OHM 1 / 16 W 1608 5.00% D	
		R907	0RH4701C622	O	O	RESISTOR,METAL GLAZED(CHIP)	4.7K OHM 1 / 16 W 1608 5.00% D	
		R908	0RH1002C622	O	O	RESISTOR,METAL GLAZED(CHIP)	10K OHM 1 / 16 W 1608 5.00% D	
		R909	0RH1002C622	O	O	RESISTOR,METAL GLAZED(CHIP)	10K OHM 1 / 16 W 1608 5.00% D	
		R910	0RH3301C622	O	O	RESISTOR,METAL GLAZED(CHIP)	3.3K OHM 1 / 16 W 1608 5.00% D	
		R911	0RH3300C622	O	O	RESISTOR,METAL GLAZED(CHIP)	330 OHM 1 / 16 W 1608 5.00% D	
		R912	0RH2200C622	O	O	RESISTOR,METAL GLAZED(CHIP)	220 OHM 1 / 16 W 1608 5.00% D	
		R913	0RH2200C622	O	O	RESISTOR,METAL GLAZED(CHIP)	220 OHM 1 / 16 W 1608 5.00% D	
		R914	0RH1003C622	O	O	RESISTOR,METAL GLAZED(CHIP)	100K OHM 1 / 16 W 1608 5.00% D	
		R915	0RH1003C622	O	O	RESISTOR,METAL GLAZED(CHIP)	100K OHM 1 / 16 W 1608 5.00% D	
		R916	0RH1003C622	O	O	RESISTOR,METAL GLAZED(CHIP)	100K OHM 1 / 16 W 1608 5.00% D	
		R917	0RH1003C622	O	O	RESISTOR,METAL GLAZED(CHIP)	100K OHM 1 / 16 W 1608 5.00% D	
		R918	0RH1003C622	O	O	RESISTOR,METAL GLAZED(CHIP)	100K OHM 1 / 16 W 1608 5.00% D	
		R919	0RH1003C622	O	O	RESISTOR,METAL GLAZED(CHIP)	100K OHM 1 / 16 W 1608 5.00% D	
		R920	0RH1003C622	O	O	RESISTOR,METAL GLAZED(CHIP)	100K OHM 1 / 16 W 1608 5.00% D	
		R921	0RH1003C622	O	O	RESISTOR,METAL GLAZED(CHIP)	100K OHM 1 / 16 W 1608 5.00% D	
		R922	0RH1003C622	O	O	RESISTOR,METAL GLAZED(CHIP)	100K OHM 1 / 16 W 1608 5.00% D	
		R923	0RH1003C622	O	O	RESISTOR,METAL GLAZED(CHIP)	100K OHM 1 / 16 W 1608 5.00% D	
		R924	0RH1003C622	O	O	RESISTOR,METAL GLAZED(CHIP)	100K OHM 1 / 16 W 1608 5.00% D	
		R925	0RH1003C622	O	O	RESISTOR,METAL GLAZED(CHIP)	100K OHM 1 / 16 W 1608 5.00% D	
		R926	0RH1003C622	O	O	RESISTOR,METAL GLAZED(CHIP)	100K OHM 1 / 16 W 1608 5.00% D	
		R927	0RH1003C622	O	O	RESISTOR,METAL GLAZED(CHIP)	100K OHM 1 / 16 W 1608 5.00% D	
		R928	0RH1003C622	O	O	RESISTOR,METAL GLAZED(CHIP)	100K OHM 1 / 16 W 1608 5.00% D	
		R929	0RH1003C622	O	O	RESISTOR,METAL GLAZED(CHIP)	100K OHM 1 / 16 W 1608 5.00% D	
		R930	0RH1003C622	O	O	RESISTOR,METAL GLAZED(CHIP)	100K OHM 1 / 16 W 1608 5.00% D	
		R931	0RH1003C622	O	O	RESISTOR,METAL GLAZED(CHIP)	100K OHM 1 / 16 W 1608 5.00% D	
		R932	0RH1003C622	O	O	RESISTOR,METAL GLAZED(CHIP)	100K OHM 1 / 16 W 1608 5.00% D	
		R933	0RH1003C622	O	O	RESISTOR,METAL GLAZED(CHIP)	100K OHM 1 / 16 W 1608 5.00% D	
		R934	0RH1003C622	O	O	RESISTOR,METAL GLAZED(CHIP)	100K OHM 1 / 16 W 1608 5.00% D	
		R935	0RH1003C622	O	O	RESISTOR,METAL GLAZED(CHIP)	100K OHM 1 / 16 W 1608 5.00% D	
		R936	0RH1003C622	O	O	RESISTOR,METAL GLAZED(CHIP)	100K OHM 1 / 16 W 1608 5.00% D	
		R937	0RH1003C622	O	O	RESISTOR,METAL GLAZED(CHIP)	100K OHM 1 / 16 W 1608 5.00% D	
		R938	0RH1003C622	O	O	RESISTOR,METAL GLAZED(CHIP)	100K OHM 1 / 16 W 1608 5.00% D	
		R944	0RH0000C622		O	RESISTOR,METAL GLAZED(CHIP)	0 OHM 1 / 16 W 1608 5.00% D	
		R951	0RH1000C622		O	RESISTOR,METAL GLAZED(CHIP)	100 OHM 1 / 16 W 1608 5.00% D	
		R952	0RH1000C622		O	RESISTOR,METAL GLAZED(CHIP)	100 OHM 1 / 16 W 1608 5.00% D	
		RC901	6712R1038GA		O	REMOTE CONTROLLER RECEIVER	TSOP2438SB1 VISHAY 38KHZ 10.2M	
		RC901	6712R1038GA	O		REMOTE CONTROLLER RECEIVER	TSOP2438SB1 VISHAY 38KHZ 10.2M	
		X201	6212AA2200E	O	O	RESONATOR,CRYSTAL	HC-49S CSC(SSANGTAI) 20.000000	
		X501	6202R-BL06C	O	O	RESONATOR,CRYSTAL	HC-49/S BUBANG 27MHZ 20PPM 1	
		X901	6212BA3004A	O	O	RESONATOR,CERAMIC	CSTLS6M00G53-A0 MURATA 6MHZ +/-	
		ZD101	0DZ560009CJ	O	O	DIODE,ZENERS	GDZJ5.6B 26MM GRANDE TP26 DO34	
		ZD102	0DZ332609FB	O	O	DIODE,ZENERS	GDZJ3.3B 26MM GRANDE TP26 DO34	

MEMO

A series of horizontal dotted lines for writing.