



SERVICE MANUAL MODEL: LF-U850D, LF-U850A, LFS-U850

MICRO HI-FI SYSTEM SERVICE MANUAL

CAUTION

BEFORE SERVICING THE UNIT, READ THE "SAFETY PRECAUTIONS" IN THIS MANUAL.

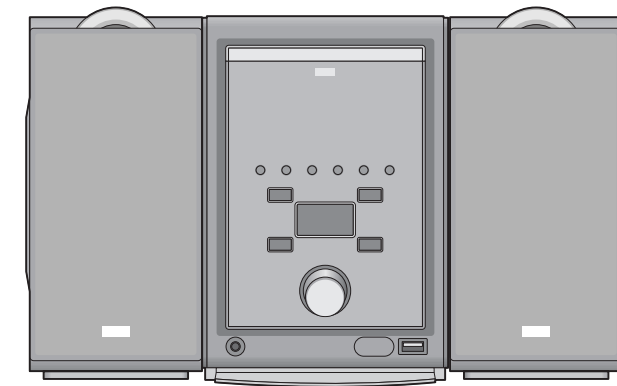

MODEL: LF-U850D, LF-U850A,
LFS-U850

[CONTENTS]

○ SECTION 1.GENERAL

- SERVICING PRECAUTIONS 1-2
- ESD PRECAUTIONS 1-4
- SPECIFICATION1-5

○ SECTION 2.ELECTRICAL SECTION

- TROUBLESHOOTING GUIDE 2-1
- INTERNAL BLOCK DIAGRAM of ICs 2-6
- BLOCK DIAGRAM 2-12
- SCHEMATIC DIAGRAMS 2-14
- CD PART 2-20
- WIRING DIAGRAM 2-26
- PRINTED CIRCUIT BOARD DIAGRAM 2-28

○ SECTION 3. EXPLODED VIEWS

- CABINET AND MAIN FRAME SECTION 3-1
- Deck Mechanism Exploded View 3-3

○ SECTION 4. SPEAKER PART

- MODEL:LFS-U850 4-1

○ SECTION 5. REPLACEMENT PARTS LIST5-1

SECTION 1. GENERAL

□ SERVICING PRECAUTIONS

NOTES REGARDING HANDLING OF THE PICK-UP

1. Notes for transport and storage

- 1) The pick-up should always be left in its conductive bag until immediately prior to use.
- 2) The pick-up should never be subjected to external pressure or impact.

Storage in conductive bag

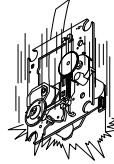
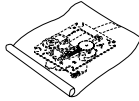

Drop impact

2. Repair notes

- 1) The pick-up incorporates a strong magnet, and so should never be brought close to magnetic materials.
- 2) The pick-up should always be handled correctly and carefully, taking care to avoid external pressure and impact. If it is subjected to strong pressure or impact, the result may be an operational malfunction and/or damage to the printed-circuit board.
- 3) Each and every pick-up is already individually adjusted to a high degree of precision, and for that reason the adjustment point and installation screws should absolutely never be touched.
- 4) Laser beams may damage the eyes!
Absolutely never permit laser beams to enter the eyes!
Also NEVER switch ON the power to the laser output part (lens, etc.) of the pick-up if it is damaged.

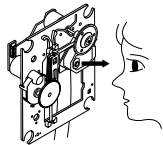

NEVER look directly at the laser beam, and don't let contact fingers or other exposed skin.

5) Cleaning the lens surface

If there is dust on the lens surface, the dust should be cleaned away by using an air bush (such as used for camera lens). The lens is held by a delicate spring. When cleaning the lens surface, therefore, a cotton swab should be used, taking care not to distort this.

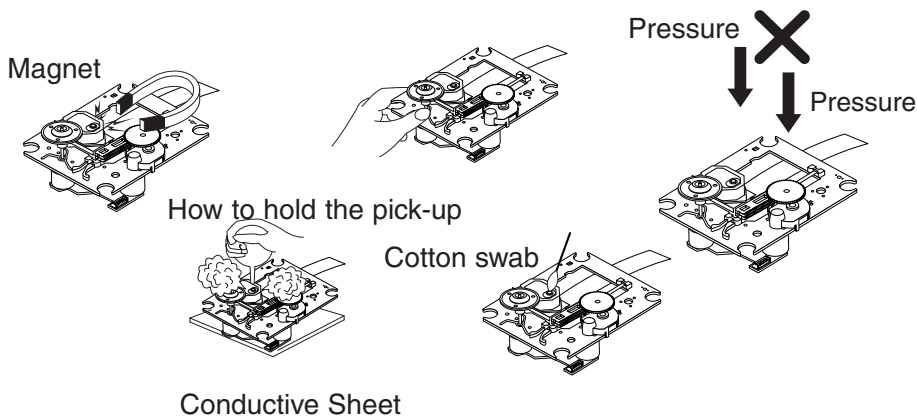

6) Never attempt to disassemble the pick-up.

Spring by excess pressure. If the lens is extremely dirty, apply isopropyl alcohol to the cotton swab. (Do not use any other liquid cleaners, because they will damage the lens.) Take care not to use too much of this alcohol on the swab, and do not allow the alcohol to get inside the pick-up.

NOTES REGARDING COMPACT DISC PLAYER REPAIRS

1. Preparations

- 1) Compact disc players incorporate a great many ICs as well as the pick-up (laser diode). These components are sensitive to, and easily affected by, static electricity. If such static electricity is high voltage, components can be damaged, and for that reason components should be handled with care.
- 2) The pick-up is composed of many optical components and other high-precision components. Care must be taken, therefore, to avoid repair or storage where the temperature or humidity is high, where strong magnetism is present, or where there is excessive dust.

2. Notes for repair

- 1) Before replacing a component part, first disconnect the power supply lead wire from the unit
- 2) All equipment, measuring instruments and tools must be grounded.
- 3) The workbench should be covered with a conductive sheet and grounded.
When removing the laser pick-up from its conductive bag, do not place the pick-up on the bag. (This is because there is the possibility of damage by static electricity.)
- 4) To prevent AC leakage, the metal part of the soldering iron should be grounded.
- 5) Workers should be grounded by an armband (1M Ω)
- 6) Care should be taken not to permit the laser pick-up to come in contact with clothing, in order to prevent static electricity changes in the clothing to escape from the armband.
- 7) The laser beam from the pick-up should NEVER be directly facing the eyes or bare skin.

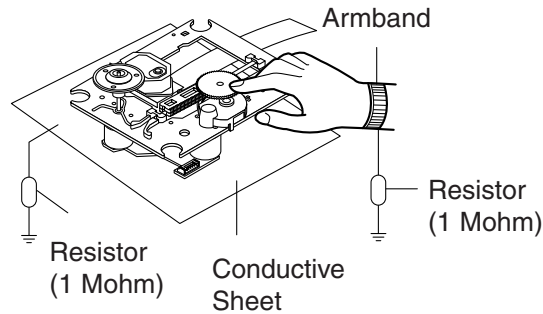

CLEARING MALFUNCTION

You can reset your unit to initial status if malfunction occur(button malfunction, display, etc.).

Using a pointed good conductor(such as driver), simply short the RESET jump wire on the inside of the volume knob for more than 3 seconds.

If you reset your unit, you must reenter all its settings(stations, clock, timer)

NOTE: 1. To operate the RESET jump wire, pull the volume rotary knob and release it.

2. If you wish to operate the RESET jump wire, it is necessary to unplug the power cord.

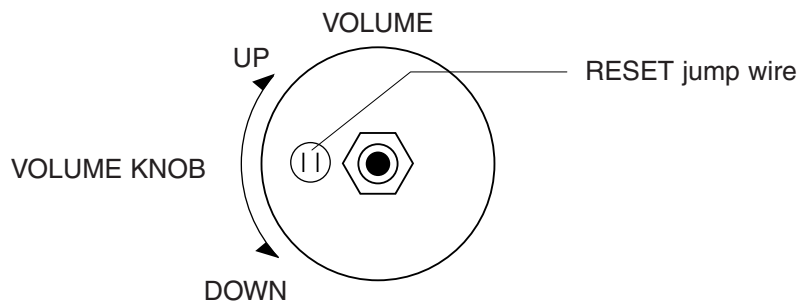

ESD PRECAUTIONS

Electrostatically Sensitive Devices (ESD)



Some semiconductor (solid state) devices can be damaged easily by static electricity. Such components commonly are called Electrostatically Sensitive Devices (ESD). Examples of typical ESD devices are integrated circuits and some field-effect transistors and semiconductor chip components. The following techniques should be used to help reduce the incidence of component damage caused by static electricity.

1. Immediately before handling any semiconductor component or semiconductor-equipped assembly, drain off any electrostatic charge on your body by touching a known earth ground. Alternatively, obtain and wear a commercially available discharging wrist strap device, which should be removed for potential shock reasons prior to applying power to the unit under test.
2. After removing an electrical assembly equipped with ESD devices, place the assembly on a conductive surface such as aluminum foil, to prevent electrostatic charge buildup or exposure of the assembly.
3. Use only a grounded-tip soldering iron to solder or unsolder ESD devices.
4. Use only an anti-static solder removal device. Some solder removal devices not classified as "anti-static" can generate electrical charges sufficient to damage ESD devices.
5. Do not use freon-propelled chemicals. These can generate electrical charges sufficient to damage ESD devices.
6. Do not remove a replacement ESD device from its protective package until immediately before you are ready to install it. (Most replacement ESD devices are packaged with leads electrically shorted together by conductive foam, aluminum foil or comparable conductive materials).
7. Immediately before removing the protective material from the leads of a replacement ESD device, touch the protective material to the chassis or circuit assembly into which the device will be installed.

CAUTION : BE SURE NO POWER IS APPLIED TO THE CHASSIS OR CIRCUIT, AND OBSERVE ALL OTHER SAFETY PRECAUTIONS.

8. Minimize bodily motions when handling unpackaged replacement ESD devices. (Otherwise harmless motion such as the brushing together of your clothes fabric or the lifting of your foot from a carpeted floor can generate static electricity sufficient to damage an ESD device).

CAUTION. GRAPHIC SYMBOLS

	THE LIGHTNING FLASH WITH APROWHEAD SYMBOL. WITHIN AN EQUILATERAL TRIANGLE, IS INTENDED TO ALERT THE SERVICE PERSONNEL TO THE PRESENCE OF UNINSULATED "DANGEROUS VOLTAGE" THAT MAY BE OF SUFFICIENT MAGNITUDE TO CONSTITUTE A RISK OF ELECTRIC SHOCK.
	THE EXCLAMATION POINT WITHIN AN EQUILATERAL TRIANGLE IS INTENDED TO ALERT THE SERVICE PERSONNEL TO THE PRESENCE OF IMPORTANT SAFETY INFORMATION IN SERVICE LITERATURE.

□ SPECIFICATIONS

SECTION		MODEL	LF-U850D/A
[General]	Power supply	Refer to the back panel of the unit.	
	Power consumption	50 W	
	Mass	3.7 kg	
	Battery Operation	187 X 255 X 257 mm	
[CD]	Frequency response	40 - 18000 Hz	
	Signal-to-noise ratio	70 dB	
	Dynamic range	70 dB	
[TUNER]	[FM]	Tuning Range	87.5 - 108.0 MHz or 65 - 74 MHz, 87.5 - 108.0 MHz
		Intermediate Frequency	10.7 MHz
		Signal to Noise Ratio	60/55 dB
		Frequency Response	60 - 10000 Hz
	[AM] (MW)	Tuning Range	522 - 1620 kHz or 520 - 1720 kHz
		Intermediate Frequency	450 kHz
		Signal to Noise Ratio	34 dB
		Frequency Response	120 - 2000 Hz
[Amp]	Output Power	80 W + 80 W	
	T.H.D	0.5 %	
	Frequency Response	42 - 20000 Hz	
	Signal-to-noise ratio	75 dB	
[Speakers]	Type	Bass Reflex 3Way 4Speaker	
	Impedance	6 Ω	
	Frequency Response	60 - 20000 Hz	
	Sound Pressure Level	82 dB/W (1m)	
	Rated Input Power	80 W	
	Max. Input Power	160 W	
	Net Dimensions (WxHxD)	162x320x258 mm	
Net Weight (1EA)	4.0 kg		

* Designs and specifications are subject to change without notice.

SECTION 2. ELECTRICAL SECTION

□ TROUBLESHOOTING GUIDE

P-SENS PART CHECK

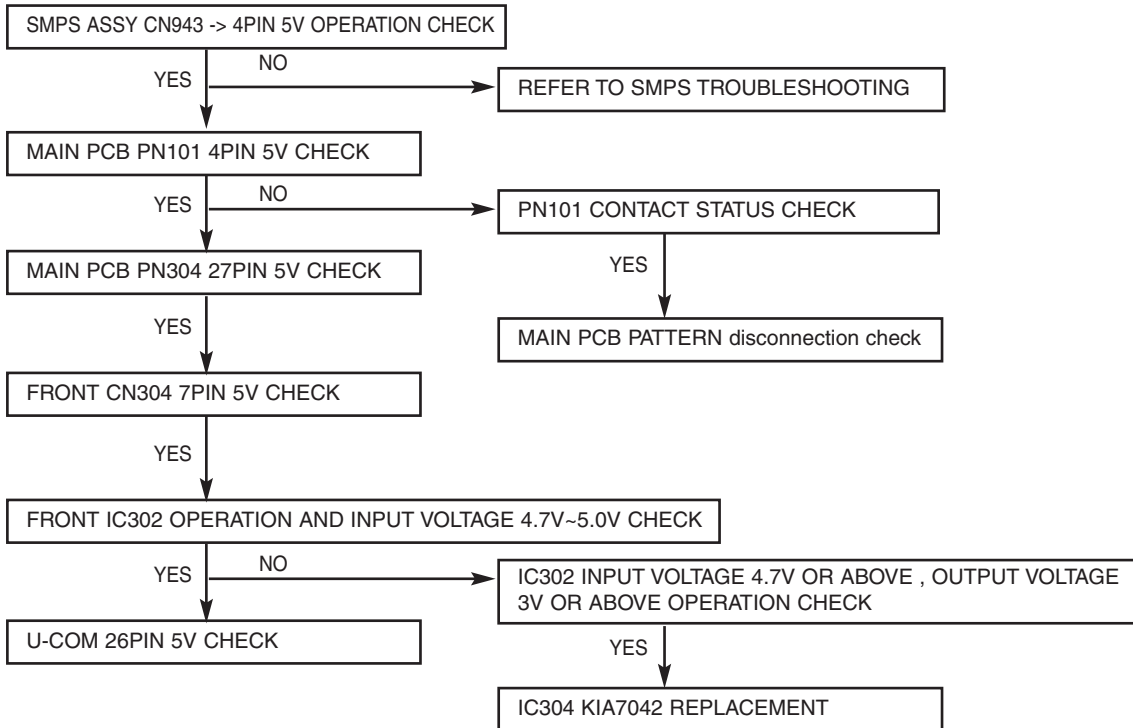

VKK CHECK

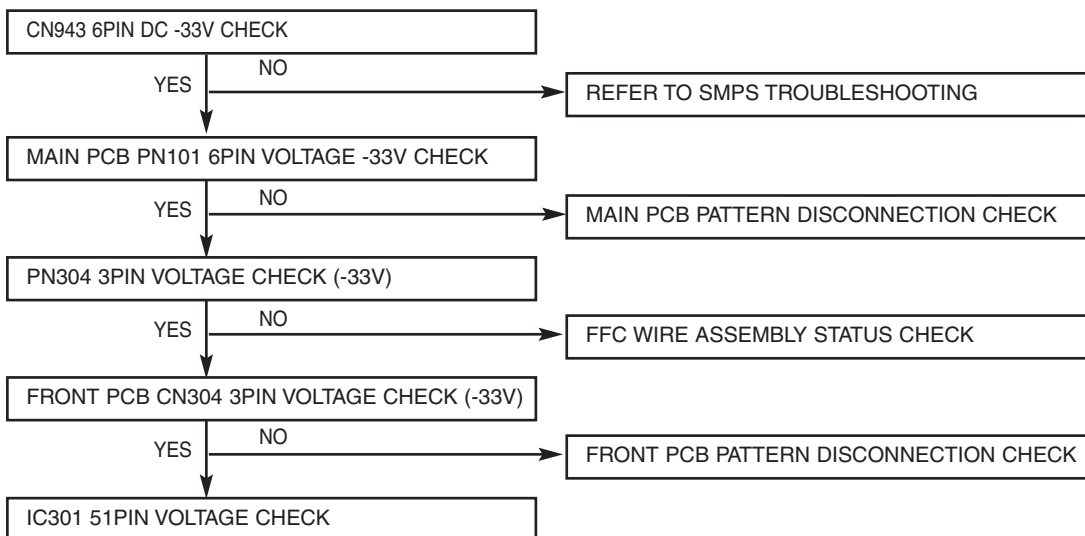

U-COM 5V VOLTAGE CHECK

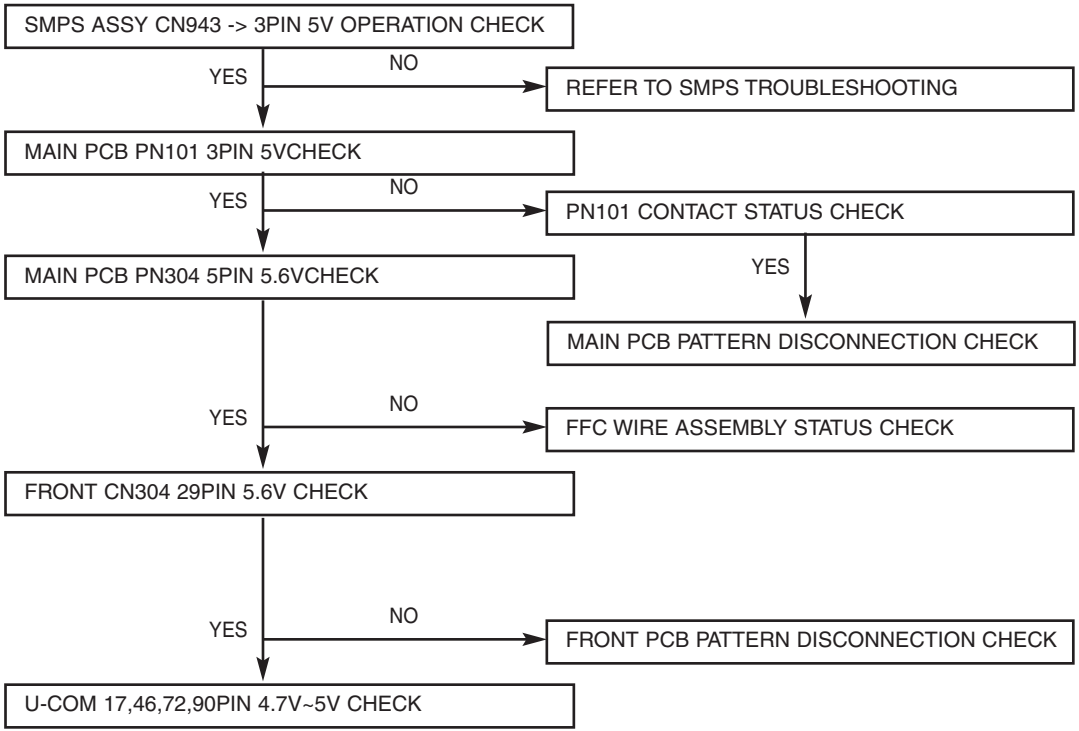

MUTING CIRCUIT TROUBLESHOOTING (ON MUTE CONDITION)

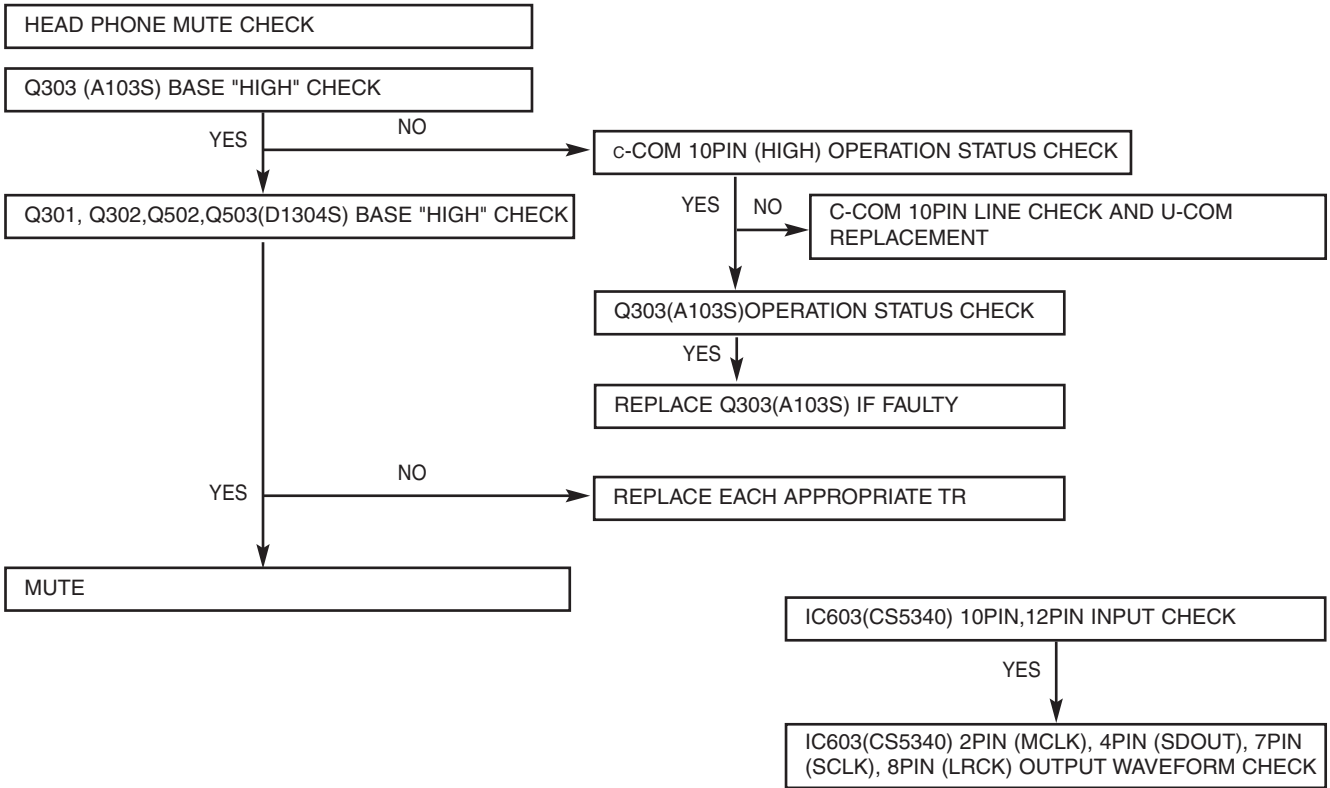

FUNCTION INPUT UNFELT (IC601 BU4052)

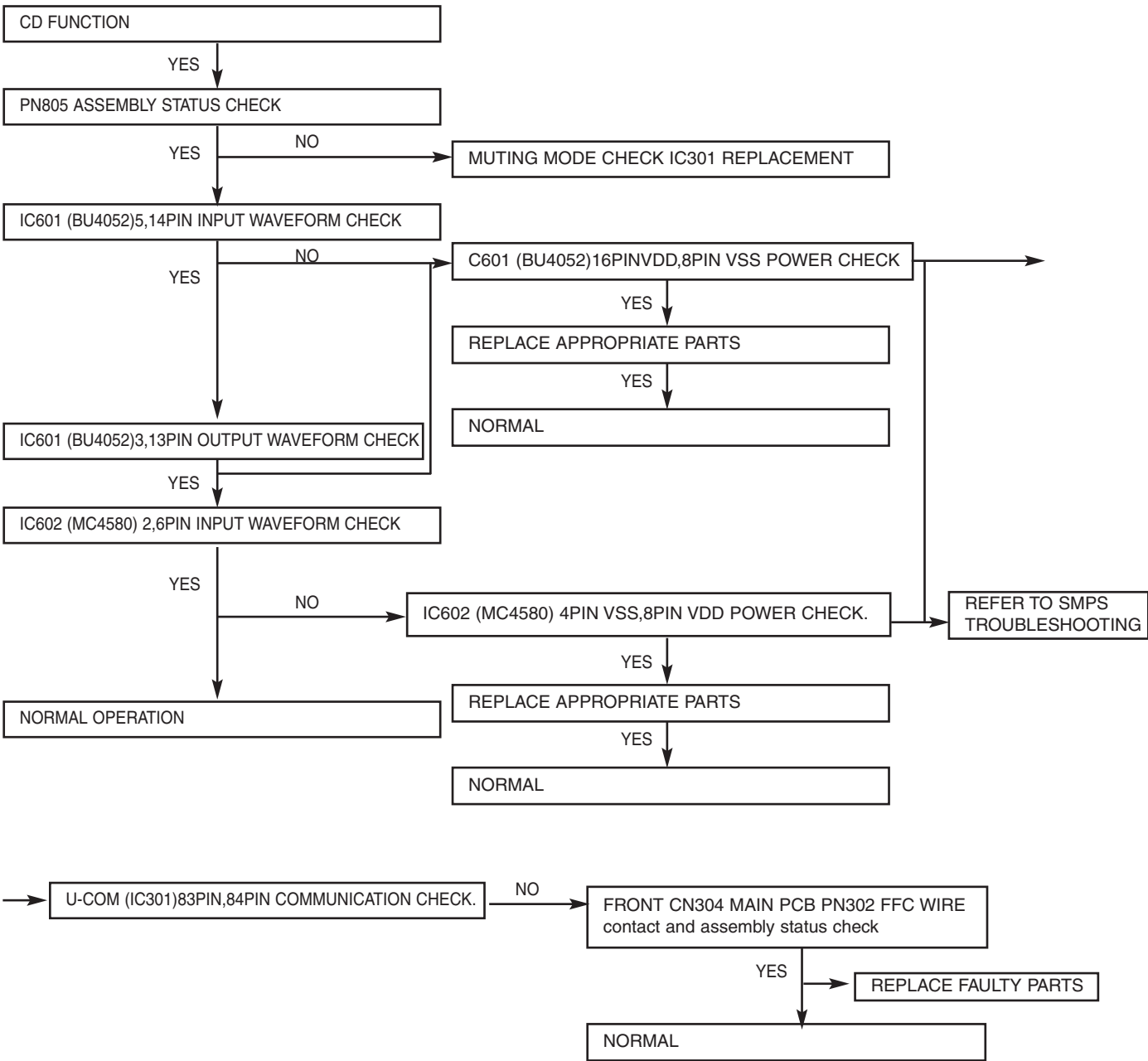

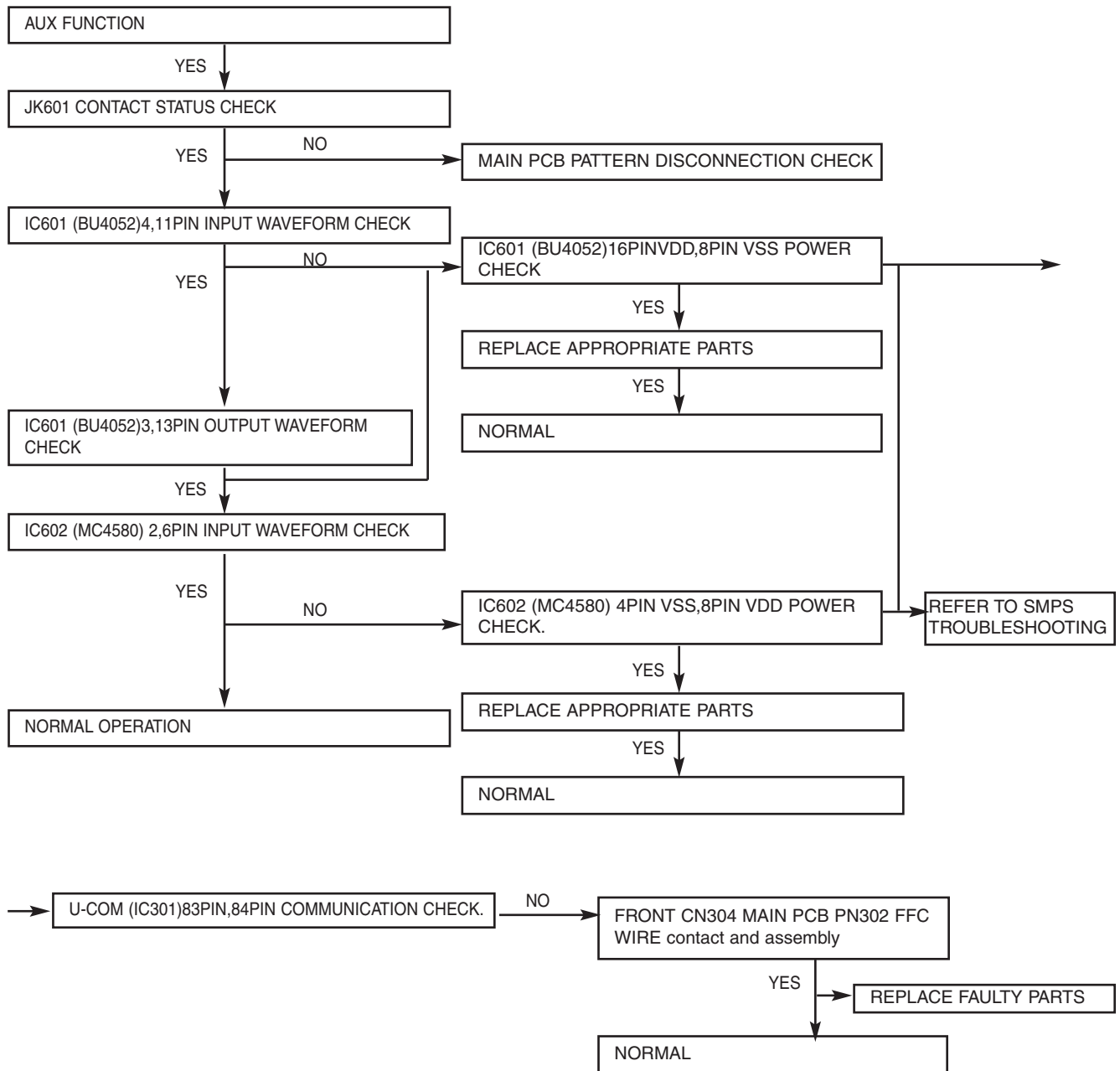

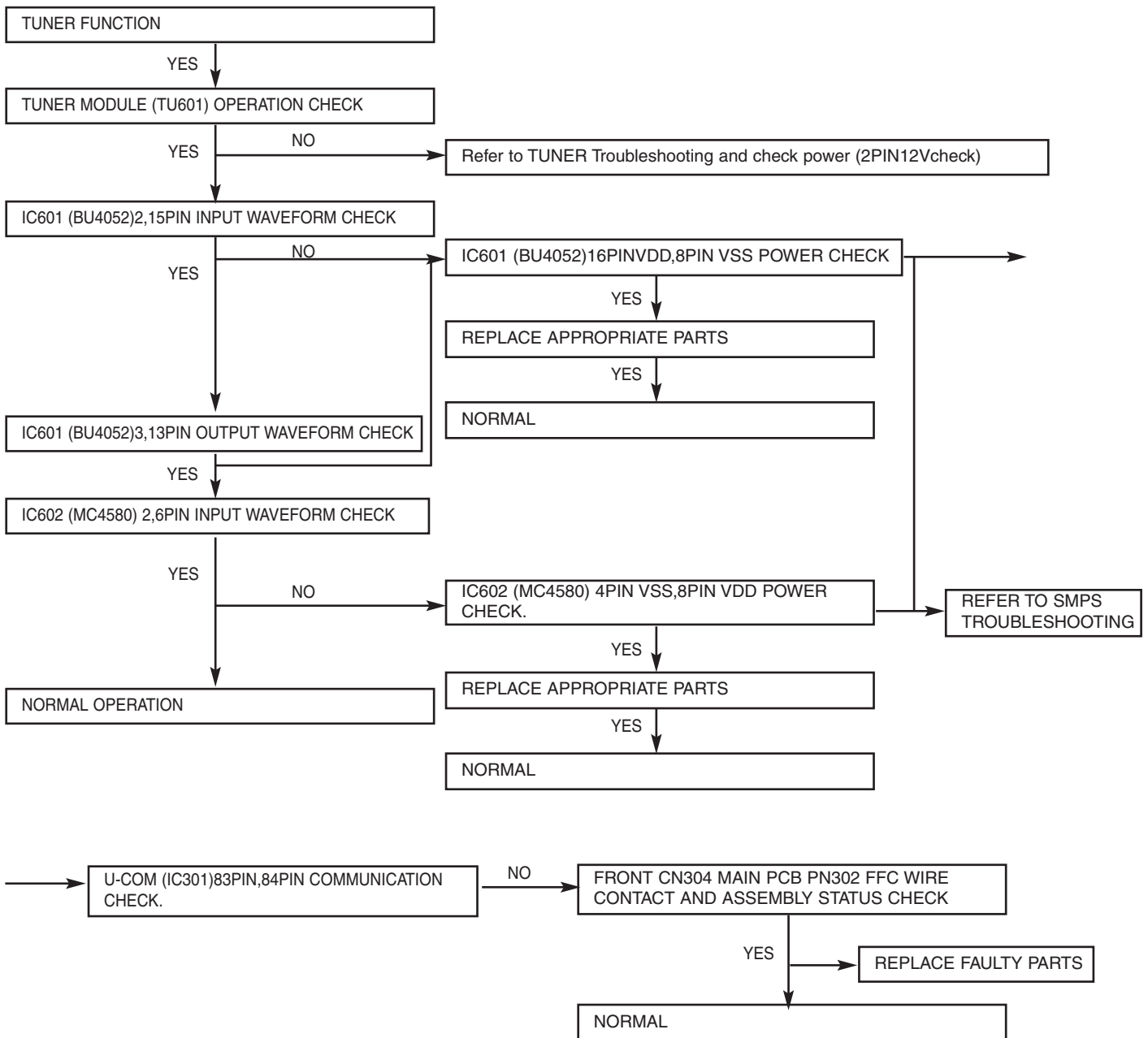

INTERNAL BLOCK DIAGRAM of ICs

• MSGEQ7 BLOCK DIAGRAM

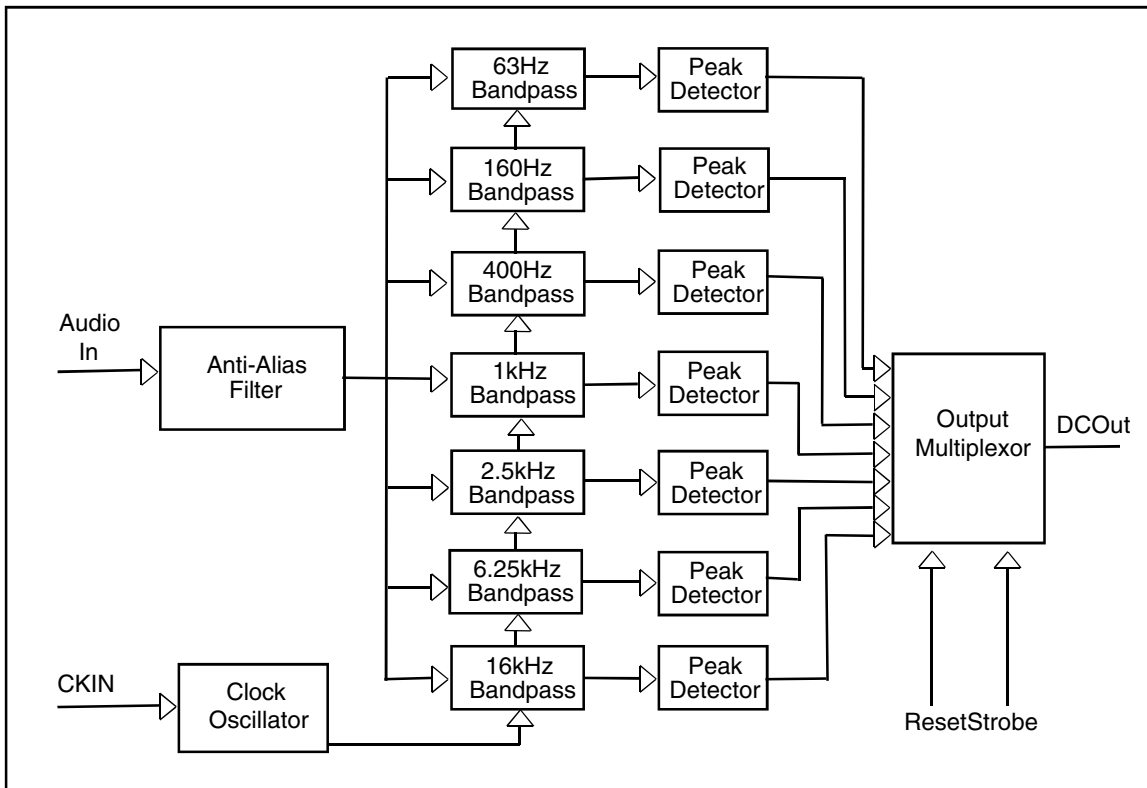

• UTC MC4580 PIN CONFIGURATION

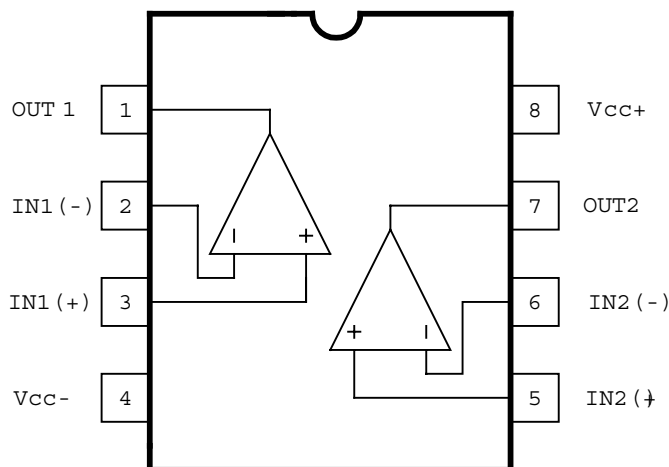

• **PS9813**
BLOCK DIAGRAM

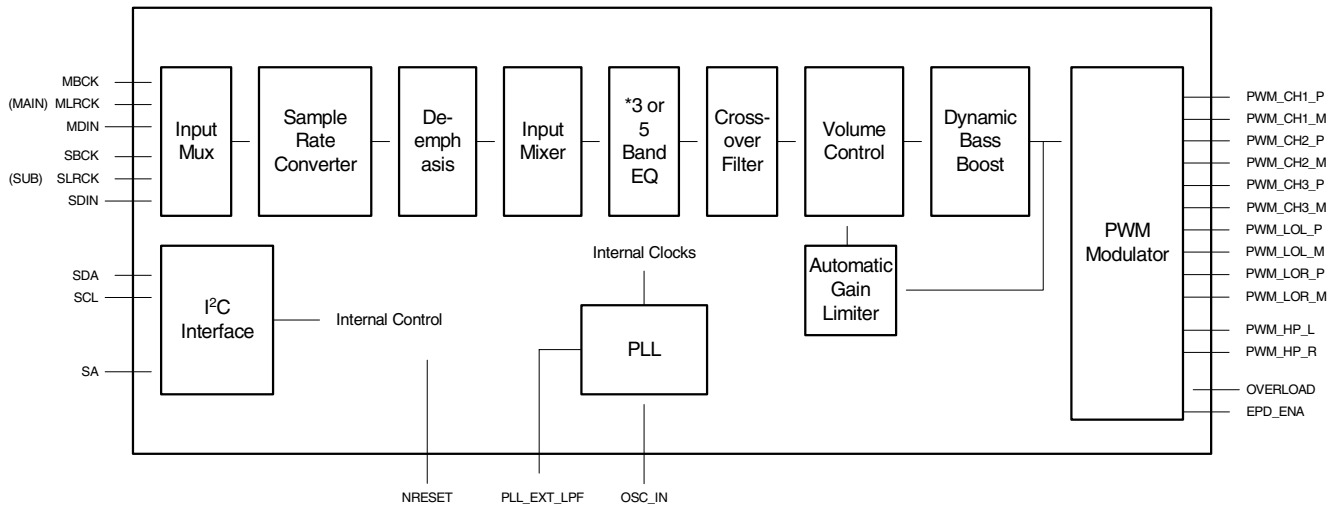

PIN ASSIGNMENT

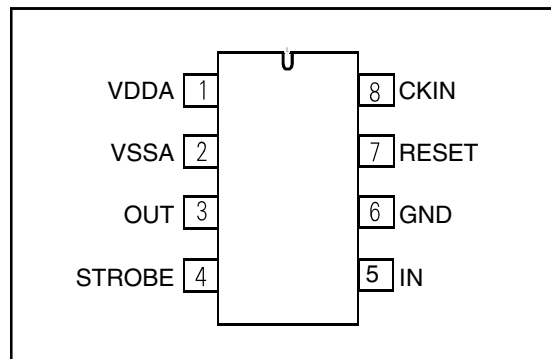

PIN DESCRIPTIONS

Name	Pin NO.	Type	Description
Power and Ground			
PLL_AVDD	2	Analog Power	PLL analog power supply. 2.5V supply voltage.
PLL_AVSS	5	Analog Ground	PLL analog ground.
PLL_DVDD	1	PLL Power	PLL peripheral digital power supply. 2.5V supply voltage.
PLL_DVSS	6	PLL Ground	PLL digital ground.
PLL_AGS	4	PLL Ground	PLL Analog Ground Sensing.
VDD	11,38	Power	2.5V Digital power supply. Core power supply.
VSS	12, 37	Ground	Core digital ground.
IO_VDD	13,27,46	Power	3.3V Digital power supply. I/O power supply.
IO_VSS	12,20,30,45	Ground	I/O digital ground.
System Services			
/RESET	10	I	H/W reset signal. Active Low Schmitt-Trigger input. The Schmitt-Trigger input allows a slowly rising input to reset the chip reliably. The RESET signal must be asserted 'Low' during power up. De-assert 'High' for normal operation.
CLK_IN	48	I	External clock input. 12.288MHz is recommended. When the PLL_BYPASS is "LOW", the external clock input from CLK_IN is used as PLL reference clock source. The external oscillator generates 12.288MHz clock and the internal PLL generates 98.304MHz (12.288MHz x 8) system clock.
SA	7	I	Slave Address Set for Host Interface
PLL_EXT_LPF	3	Analog	External PLL low pass filter pin.
PCM Audio Input/Output Interface			
MLRCK	14	I/O	PCM Word clock (left-right clock) input/output of main 2-channel audio. User can select the master/slave mode of this signal. Schmitt-Trigger input.
MBCK	15	I/O	PCM bit clock input/output of main 2-channel audio. User can select the master/slave mode of this signal. Schmitt-Trigger input.
MSDIN	16	I	PCM serial data input of main 2-channel audio. Schmitt-Trigger input.
SLRCK	17	I/O	PCM Word clock (left-right clock) input/output of sub 2-channel audio. User can select the master/slave mode of this signal. Schmitt-Trigger input.
SBCK	18	I/O	PCM bit clock input/output of 2-channel audio. User can select the master/slave mode of this signal. Schmitt-Trigger input.
SBCK	18	I/O	PCM bit clock input/output of 2-channel audio. User can select the master/slave mode of this signal. Schmitt-Trigger input.
SSDIN	19	I/O	PCM serial data input of sub-channel audio. User can set this sub-channel data input pins to PCM serial data output pins. See the Control Register Description part.

Name	Pin NO.	Type	Description
PCM Audio Input/Output Interface			
MCLK	21	O	Main clock for external ADC. Clock frequency is 256fs.
MIC_LRCK	22	O	PCM Word clock (left-right clock) output of external microphone. Word clock rate is Fs(variable)
MIC_BCK	23	O	PCM bit clock output of external microphone. Bit clock frequency is 64 Fs (variable)
MIC_SDIN	24	I	PCM serial data input of external microphone. Schmitt-Trigger input.
PWM Audio Output			
PWM_CH1_P	44	O	Positive PWM output of channel 1.
PWM_CH1_M	43	O	Negative PWM output of channel 1.
PWM_CH2_P	42	O	Positive PWM output of channel 2.
PWM_CH2_M	41	O	Negative PWM output of channel 2.
PWM_CH3_P	40	O	Positive PWM output of channel 3.
PWM_CH3_M	39	O	Negative PWM output of channel 3.
PWM_LOL_P	34	O	Positive PWM output of Line out left
PWM_LOL_M	33	O	Negative PWM output of Line out left
PWM_LOR_P	32	O	Positive PWM output of Line out right
PWM_LOR_M	31	O	Negative PWM output of Line out right
PWM_HP_L	29	O	Positive PWM output of headphone left channel.
PWM_HP_R	28	O	Positive PWM output of headphone right channel.
System Control Interface			
SDA	9	I/O	SDA for I2C mode.
SCL	8	I	SCL for I2C mode. Schmitt-Trigger input.
Special Control Interface			
OVERLOAD	35	I	Power stage overload indication input. Polarity is programmable. Schmitt-Trigger input. When OVERLOAD is asserted, all PWM audio outputs go to "LOW" (if PWM_INVERT pin is 'LOW'). Internal pull-down resistor.
EPD_ENA	36	O	External amplifier power device enable output.
Test Mode			
TEST_MODE1	25	I	Test mode selection pin 1. In normal operation, it should be "LOW" or not connected. Internal pull-down resistor.
TEST_MODE2	26	I	Test mode selection pin 2. In normal operation, it should be "LOW" or not connected. Internal pull-down resistor.

• **TAS5142**
SYSTEM BLOCK DIAGRAM

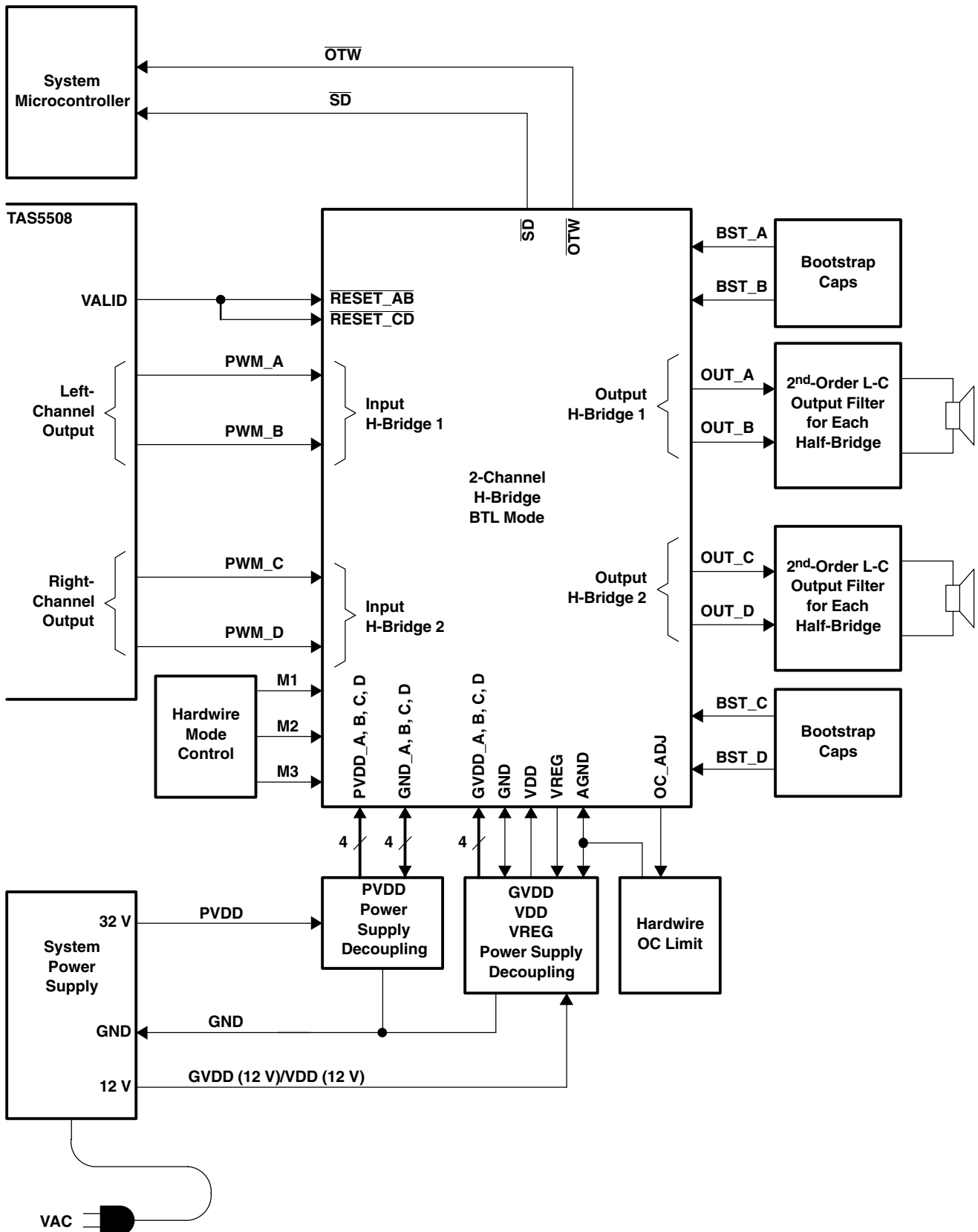

FUNCTIONAL BLOCK DIAGRAM

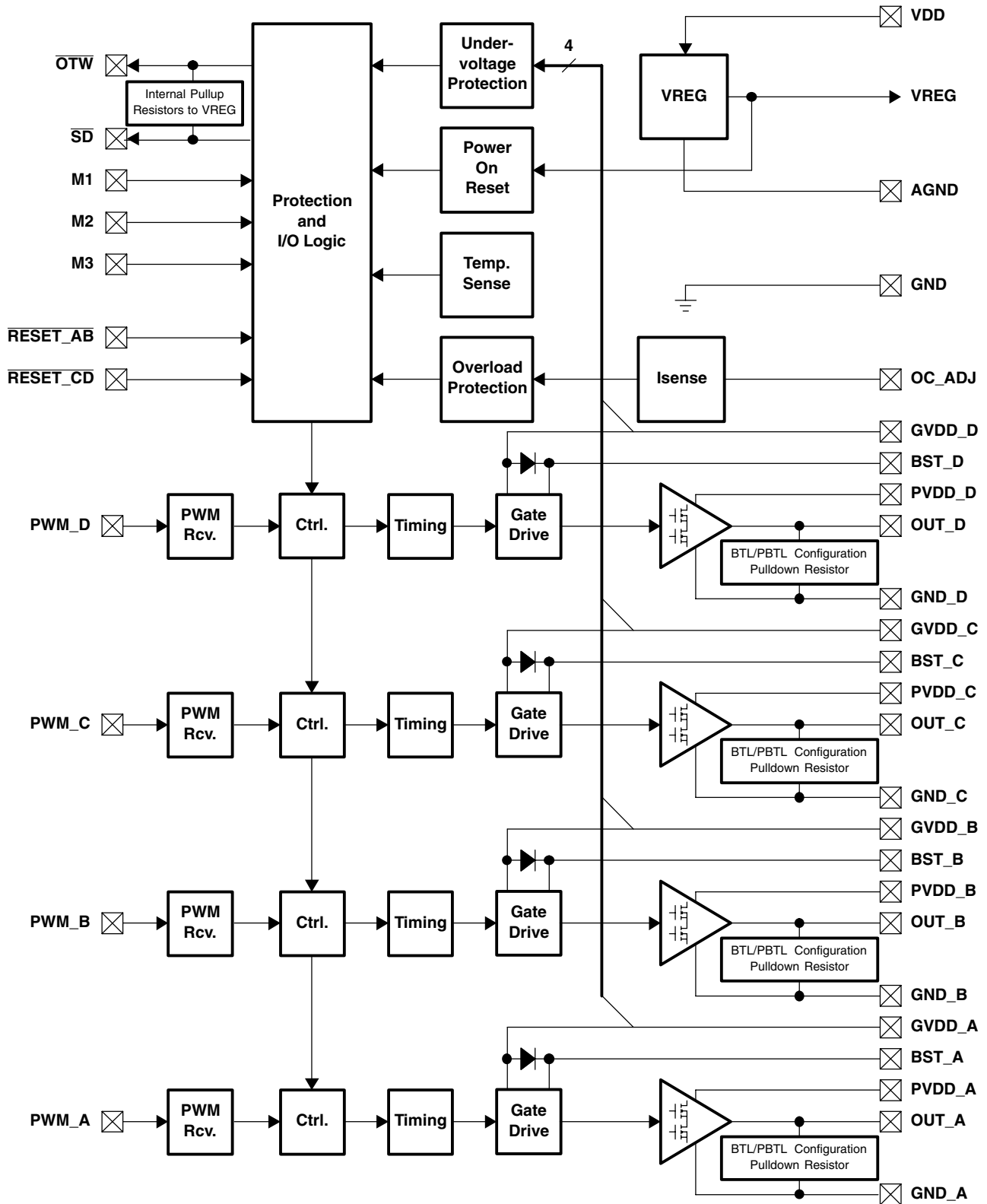

□ BLOCK DIAGRAM

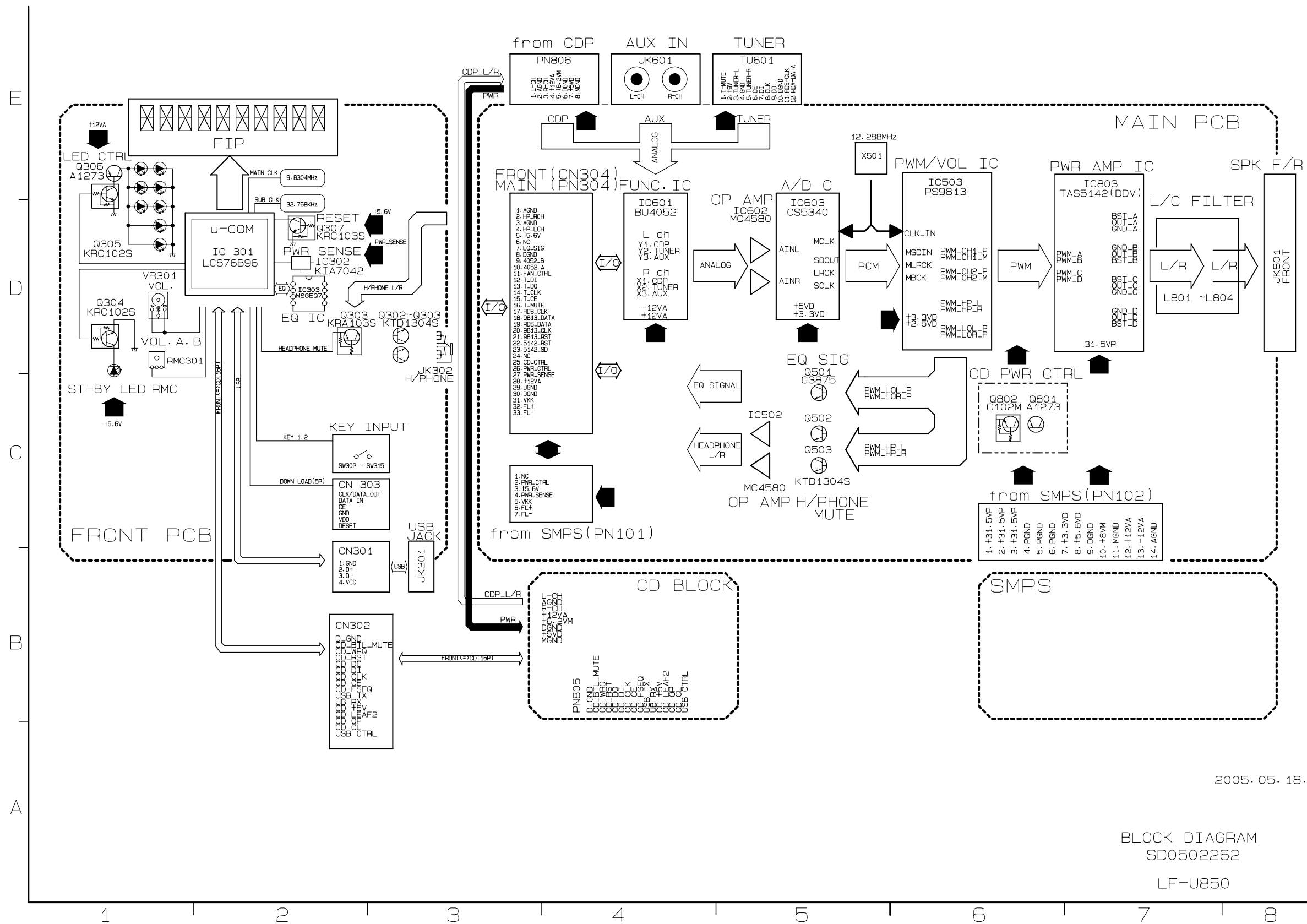

2005.05.18.

BLOCK DIAGRAM
SD0502262

LF-U850

SCHEMATIC DIAGRAMS

MAIN SCHEMATIC DIAGRAM

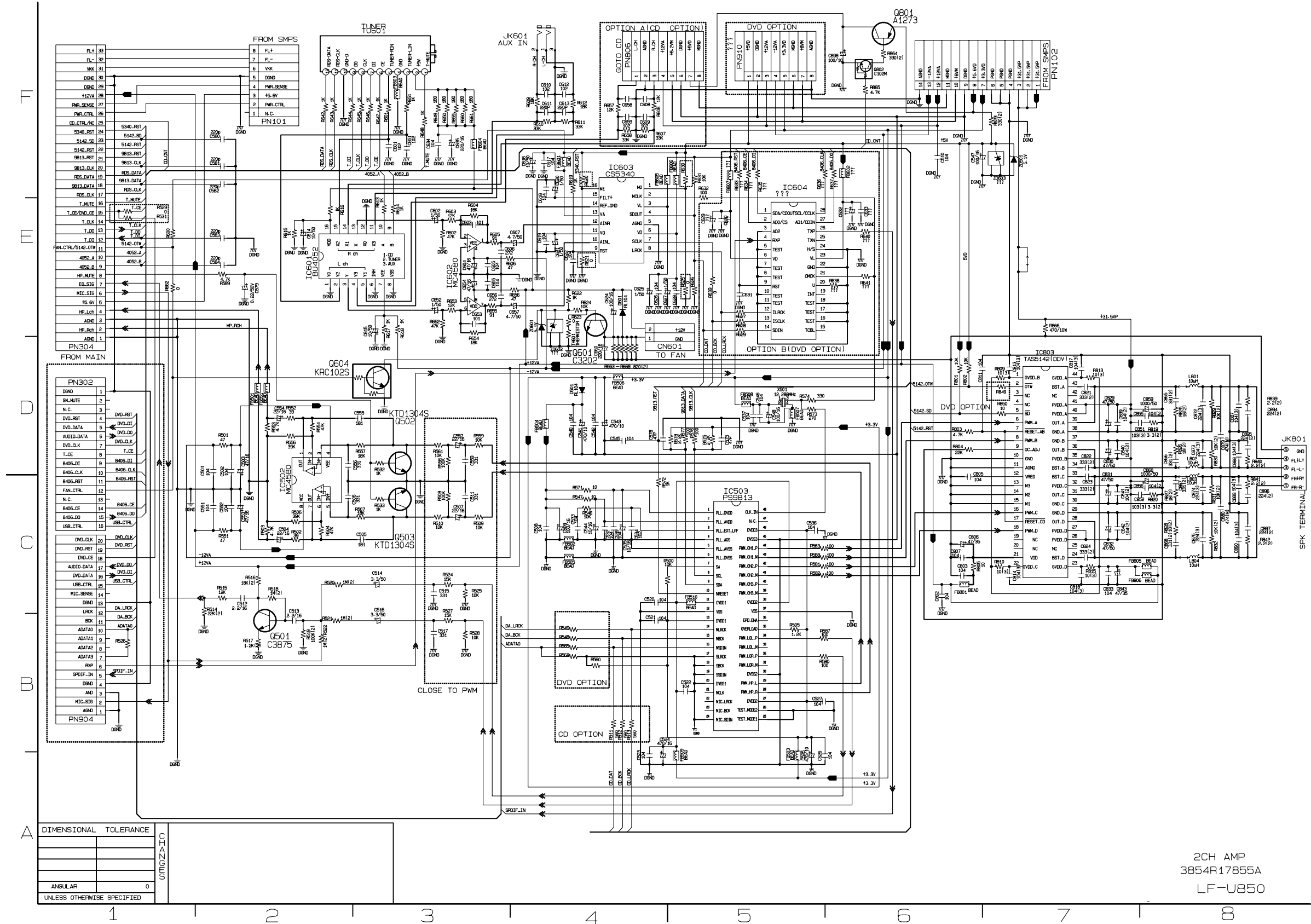

FRONT SCHEMATIC DIAGRAM

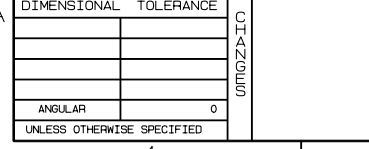
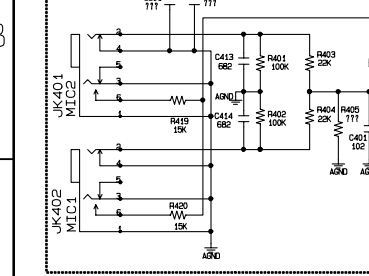
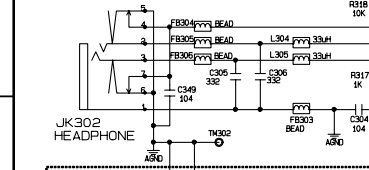
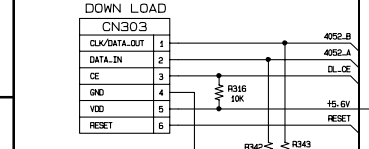
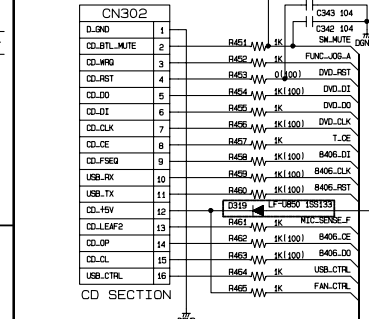
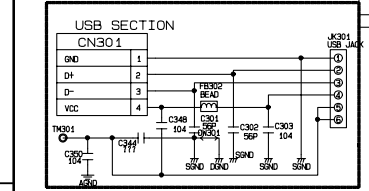
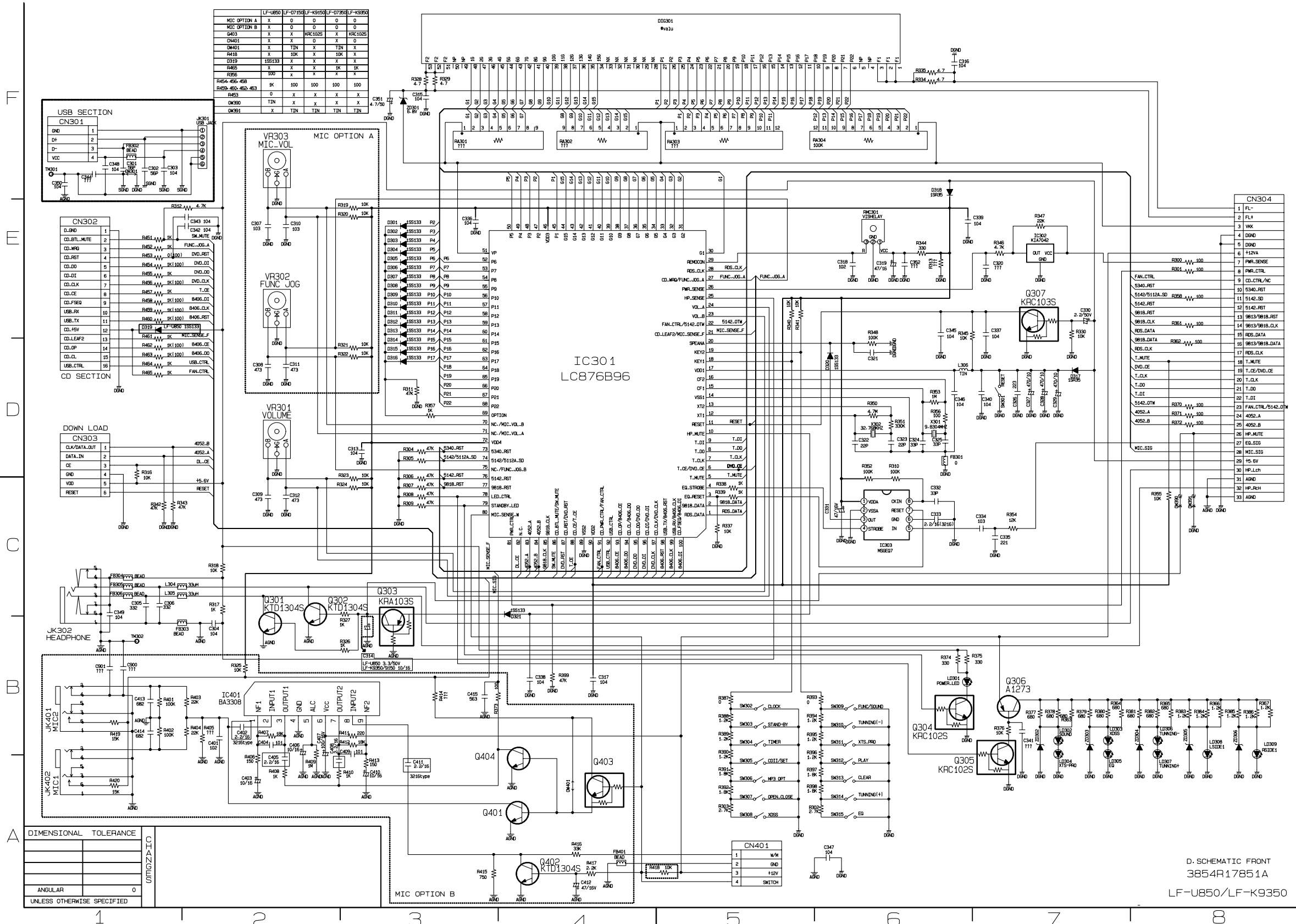

LF-U850	LF-07150	LF-K9350	LF-07350	LF-K9350
MIC OPTION A	X	0	0	0
MIC OPTION B	X	0	0	0
Q403	X	X	KRC102S	X
Q401	X	X	0	X
R418	X	TIN	TIN	X
R419	X	10K	10K	X
R420	X	X	X	X
R425	X	X	1K	5K
R426	100	X	X	X
R454-R56-458	100	100	100	100
R459-R56-463	0	X	X	X
R463	0	X	X	X
QK300	0	X	X	X
QK301	X	TIN	TIN	TIN

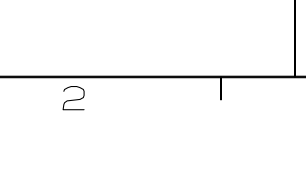
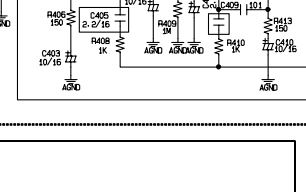
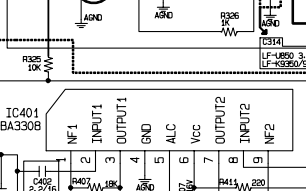
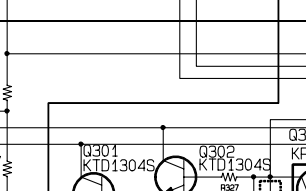
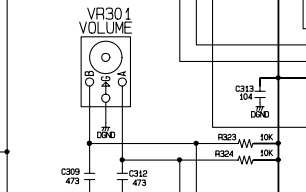
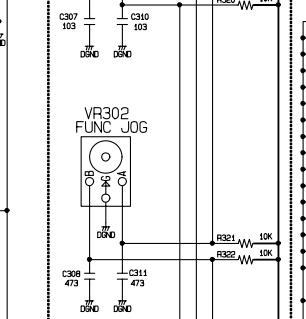
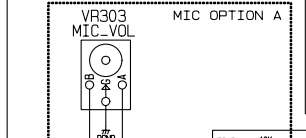

D. SCHEMATIC FRONT
3854R1785.1A
LF-U850/LF-K9350

• SMPS SCHEMATIC DIAGRAM

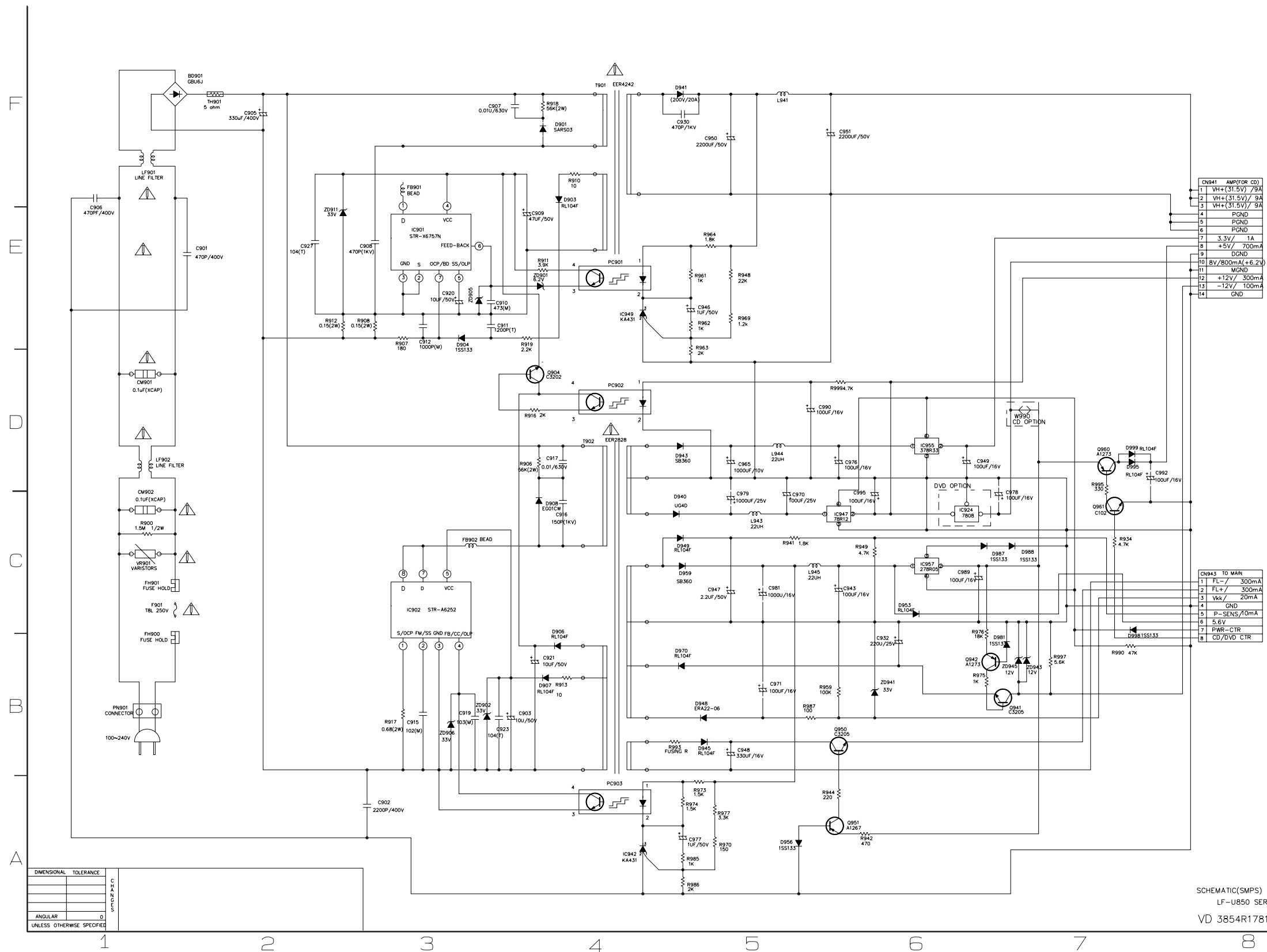

SCHEMATIC(SMPS)
 LF-U850 SERIS
 VD 3854R17815A

DIMENSIONAL	TOLERANCE
ANGULAR	0
UNLESS OTHERWISE SPECIFIED	

CD PART

WMA MODULE

OPTION TABLE

MICRO	MINI
RB21 0	RB21 XX
RB22 0	RB22 XX
RB23 0	RB23 XX
RB20 XX	RB20 0
RB48 XX	RB48 10K
RB49 XX	RB49 18K
RB50 XX	RB50 10K
RB51 XX	RB51 100
RB52 XX	RB52 68K
RB53 XX	RB53 220
RB54 XX	RB54 100
CB45 XX	CB45 0.01u
CB47 XX	CB47 1000P

MICRO	MINI
RB33 1.2K	RB33 1.2K
RB34 3.9K	RB34 6.8K

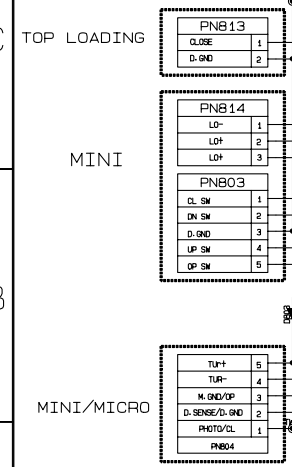
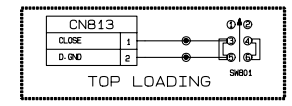
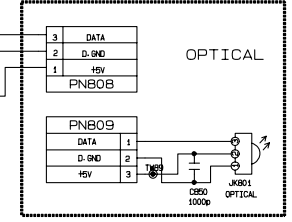
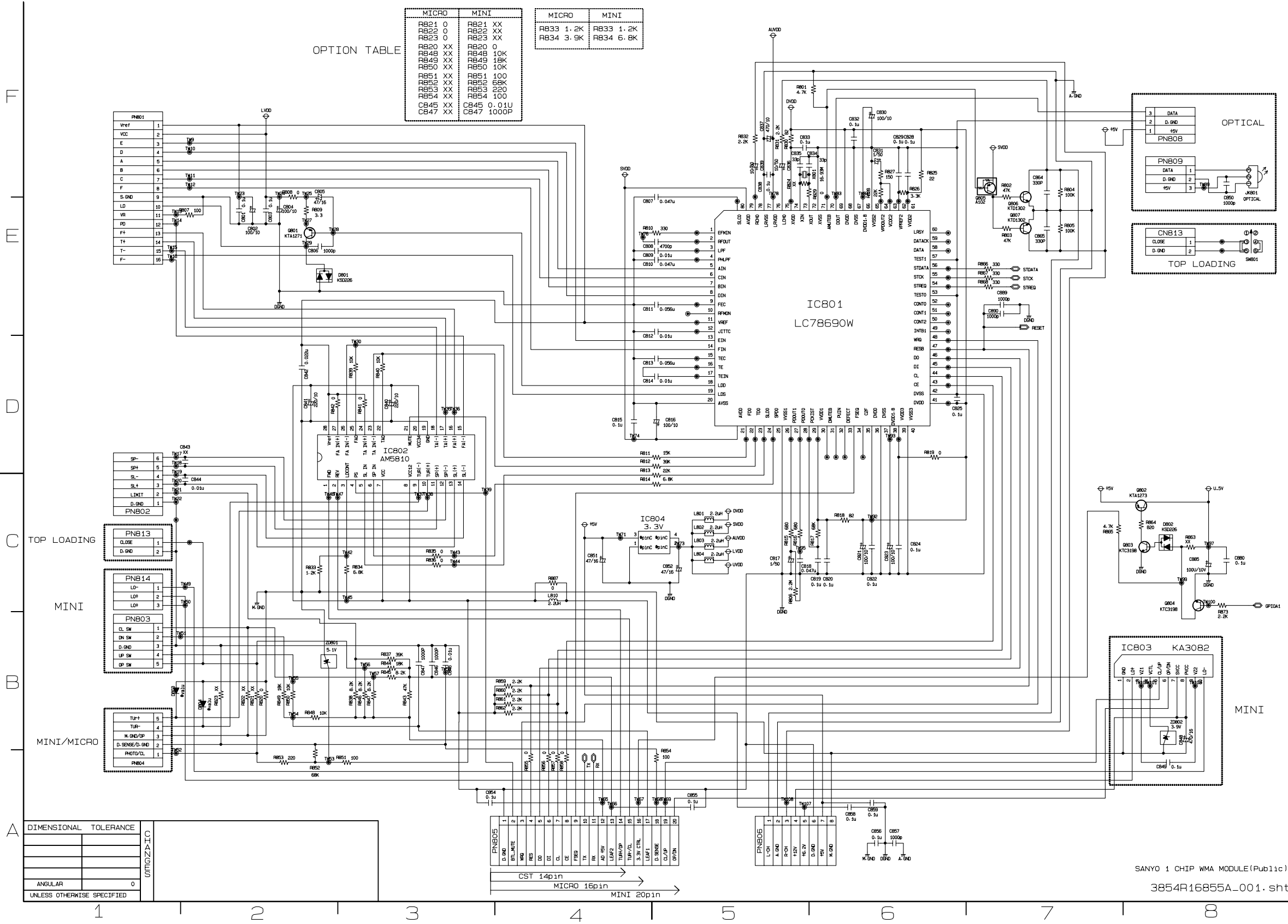

DIMENSIONAL TOLERANCE	
ANGULAR	0
UNLESS OTHERWISE SPECIFIED	

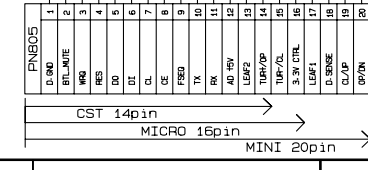

SANYO 1 CHIP WMA MODULE(Public)
3854R16855A_001.sht

• USB PART

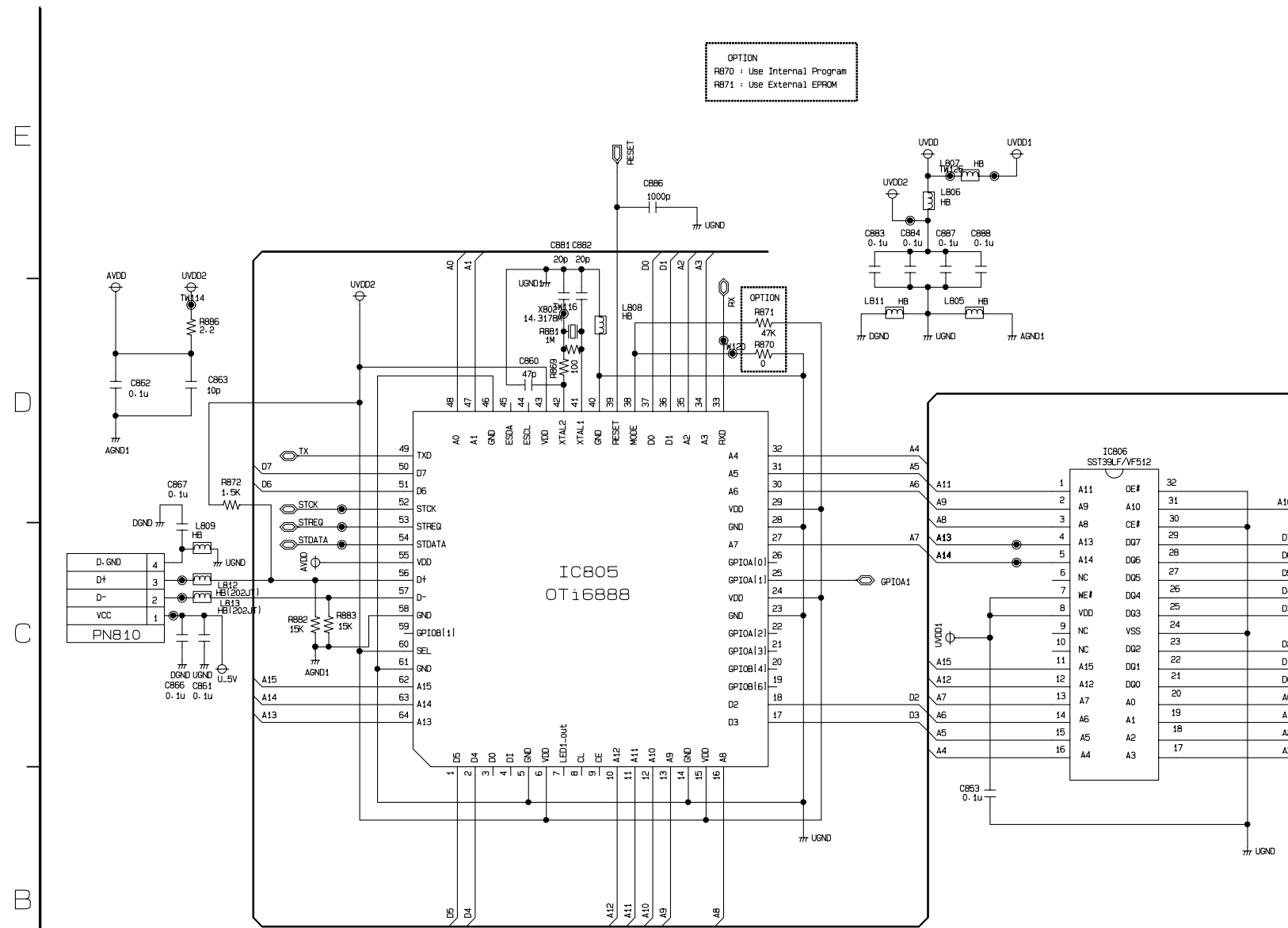

DIMENSIONAL TOLERANCE	
ANGULAR	0
UNLESS OTHERWISE SPECIFIED	

USB Part
 3854R16855A_002.sht

• WMA + USB BLOCK DIAGRAM

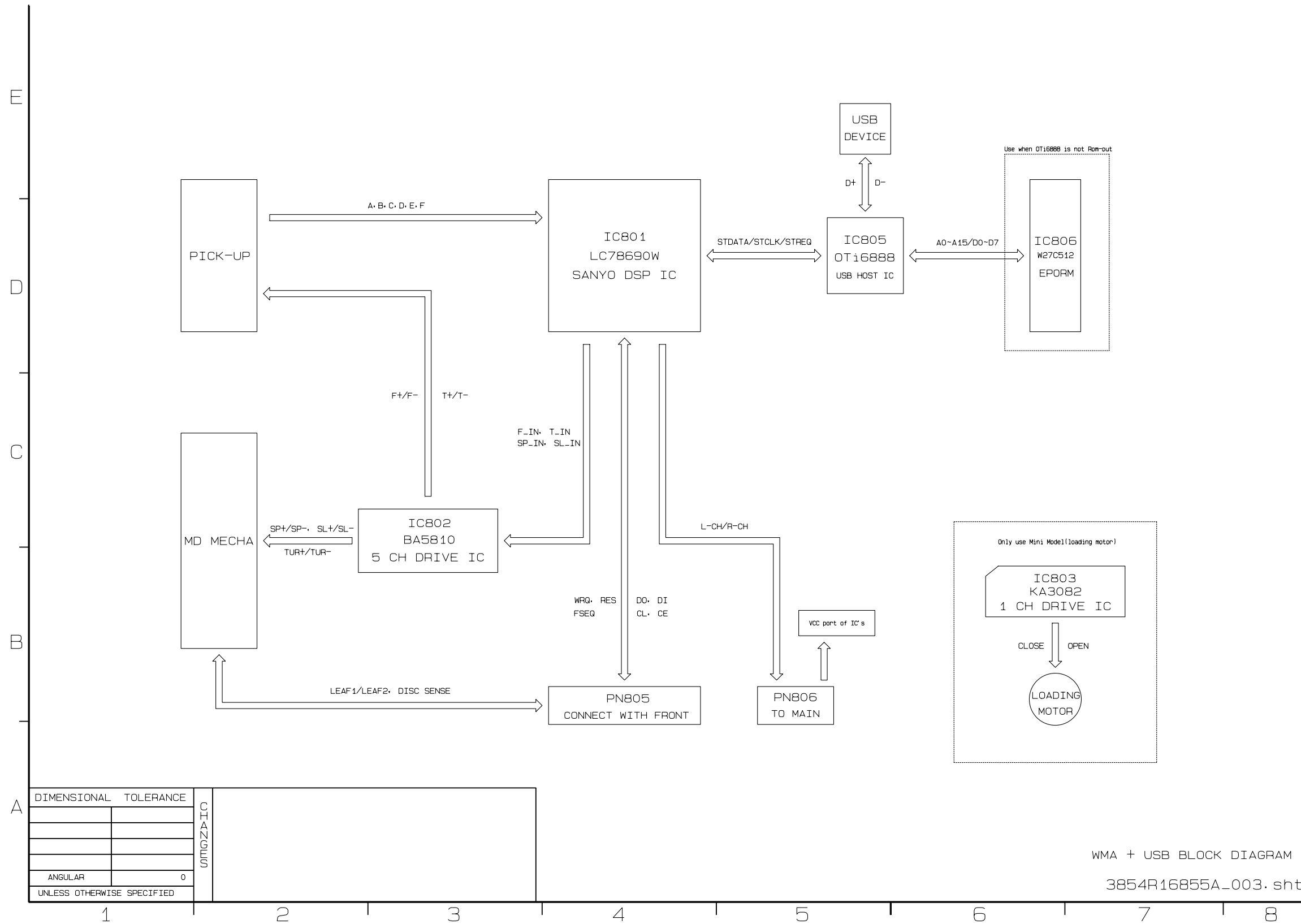

WMA + USB BLOCK DIAGRAM
3854R16855A_003.sht

WIRING DIAGRAMS

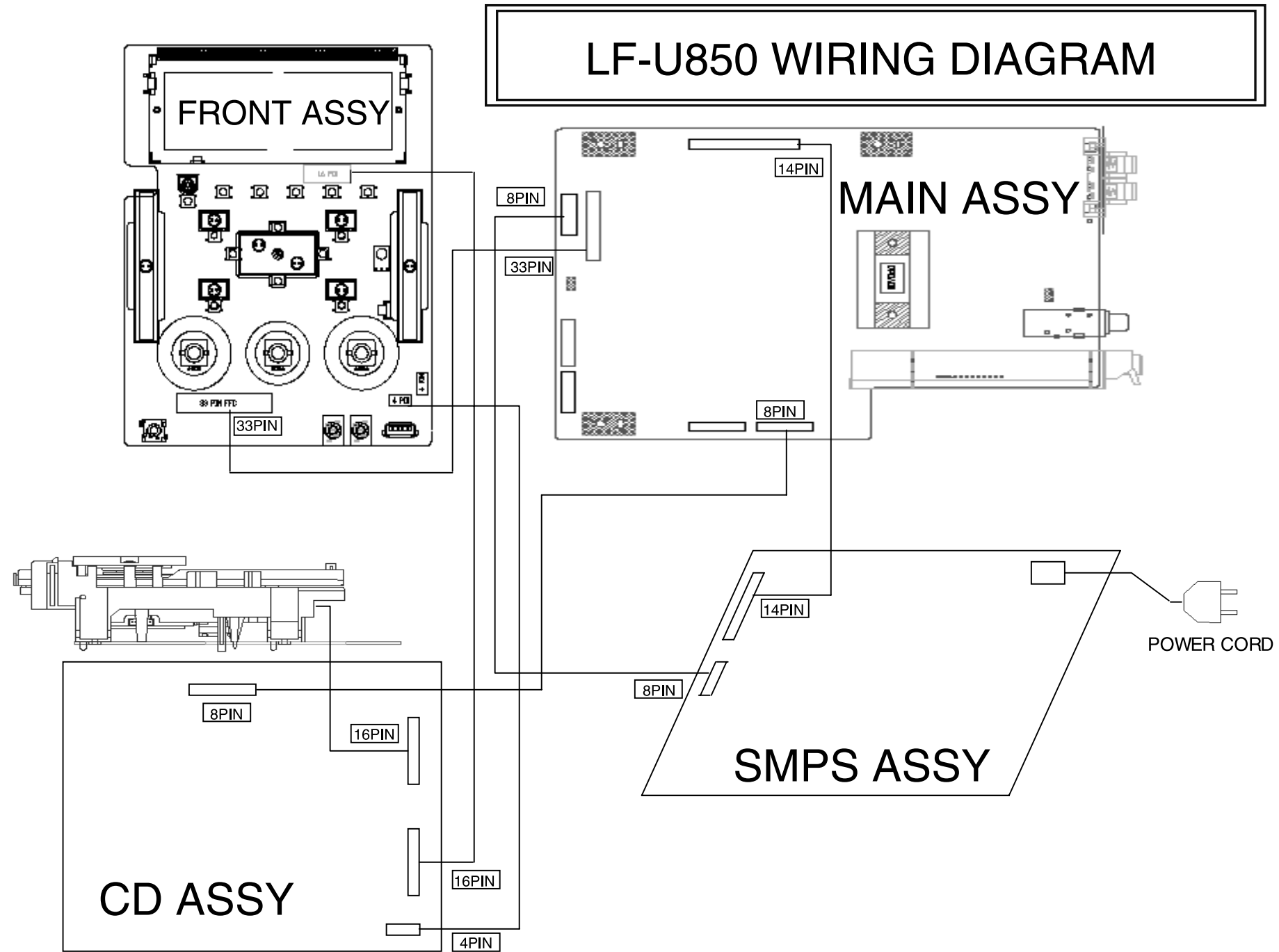

PRINTED CIRCUIT DIAGRAMS

MAIN P.C. BOARD (COMPONENT SIDE)

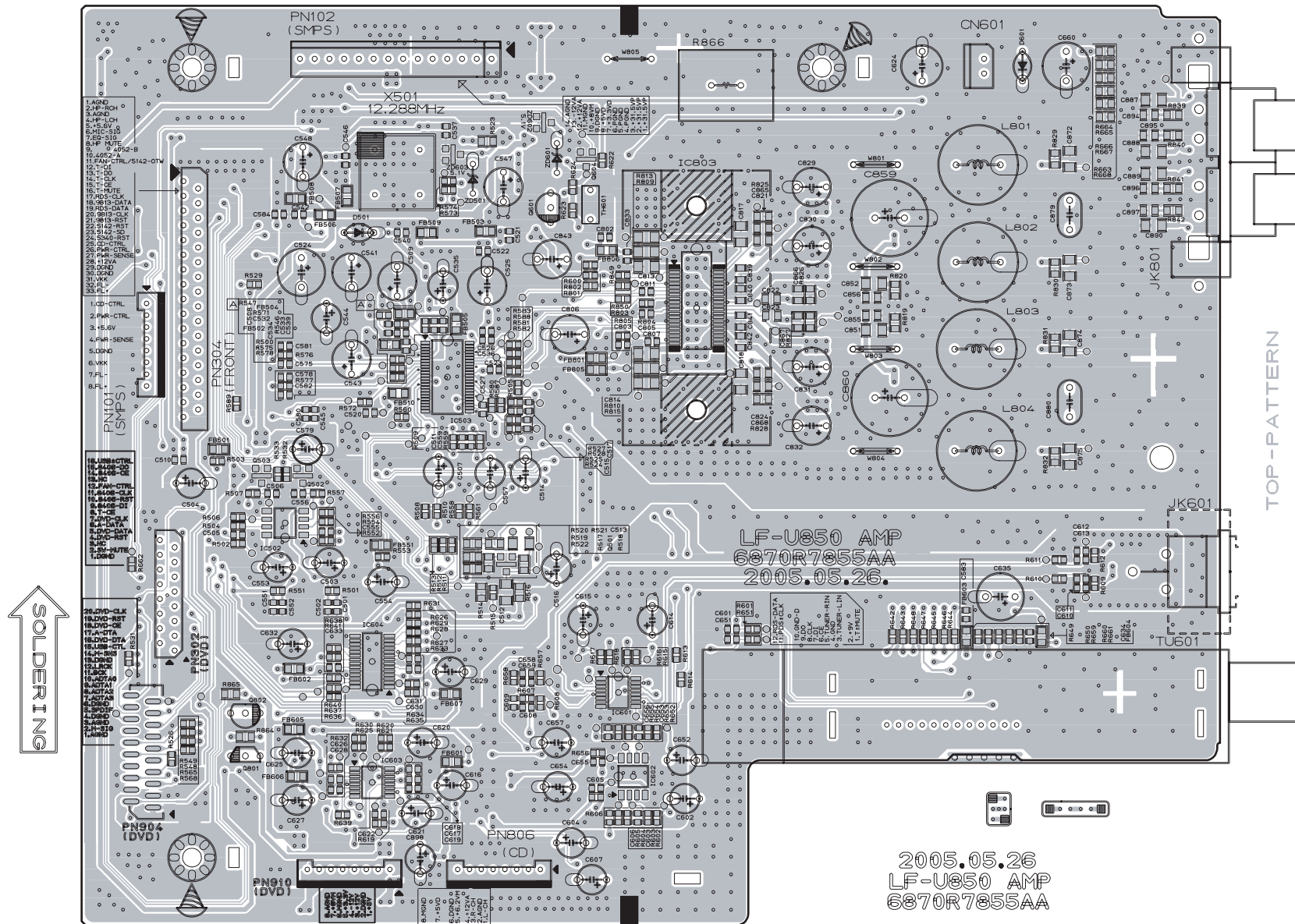

• MAIN P.C. BOARD (SOLDER SIDE)

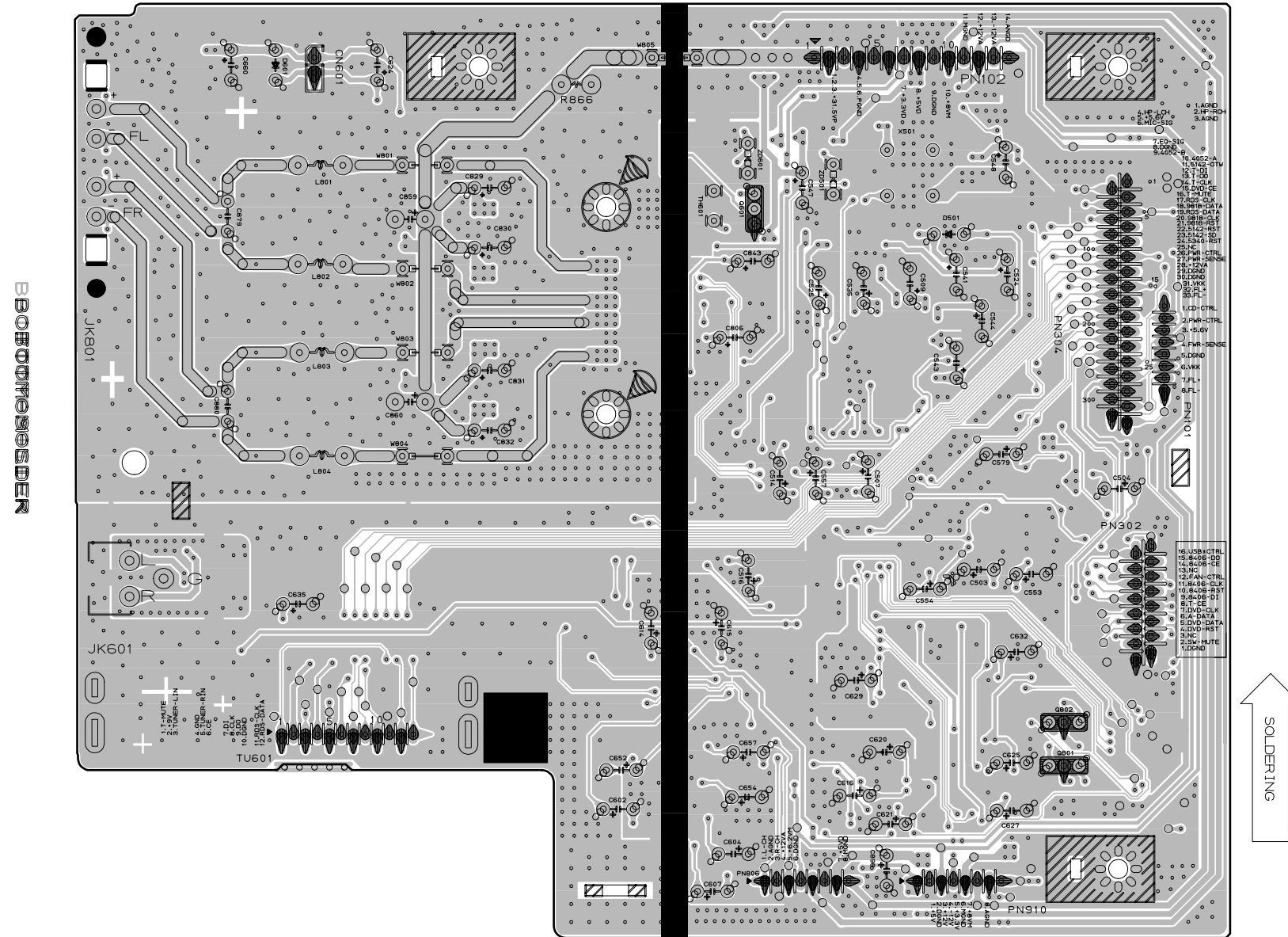

• SMPS P.C.BOARD

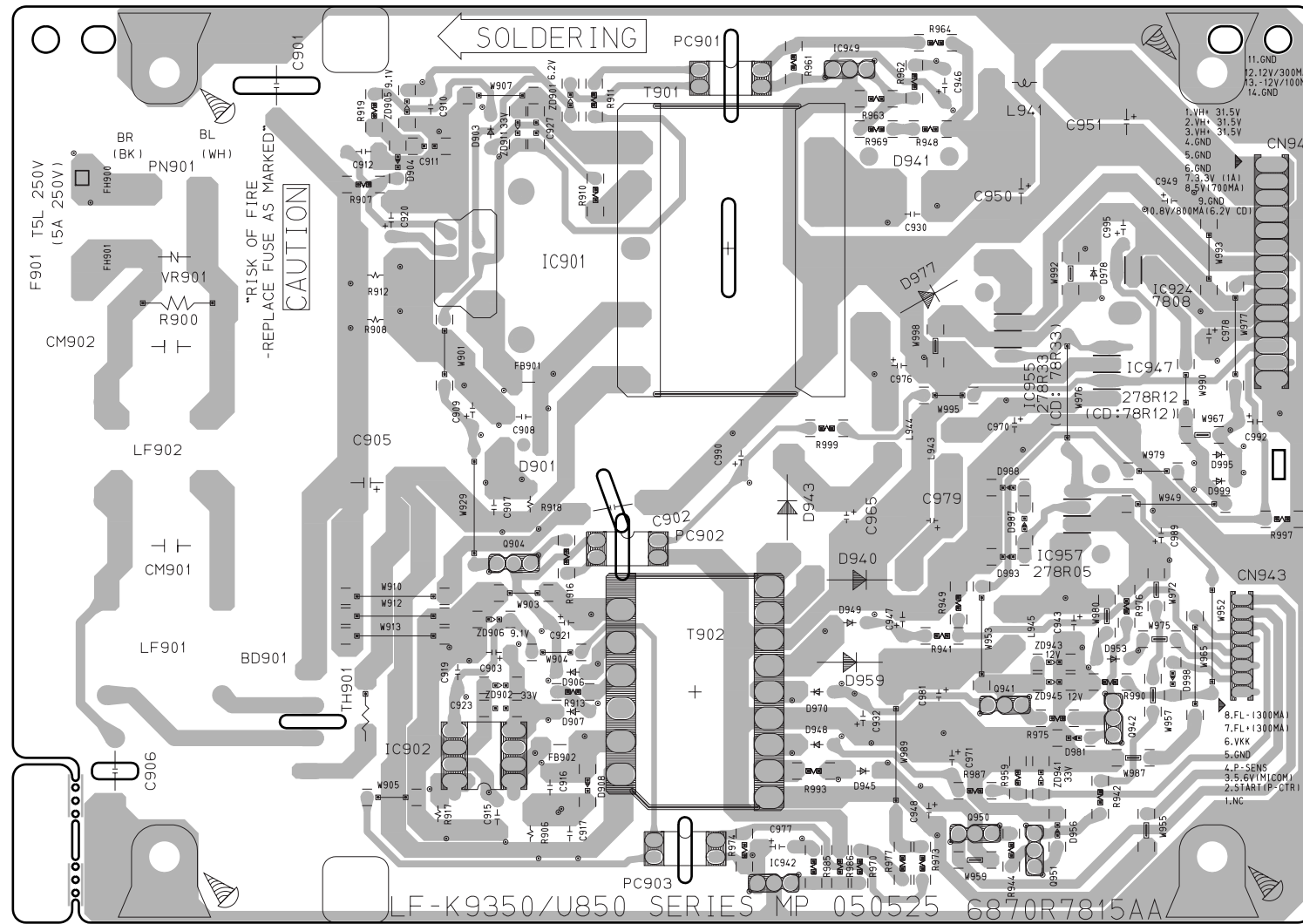

• FRONT P.C.BOARD

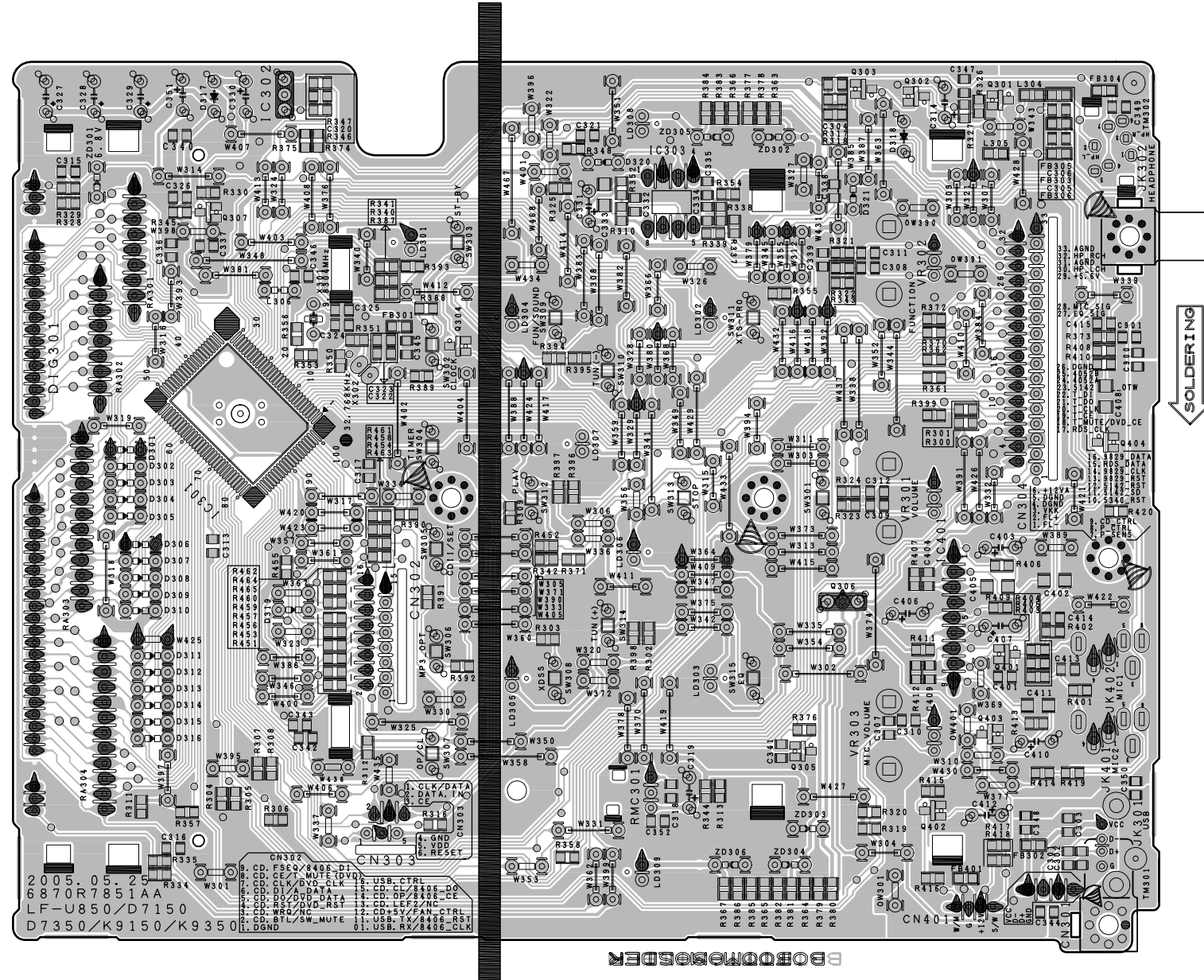

• CD P.C. BOARD (COMPONENT SIDE)

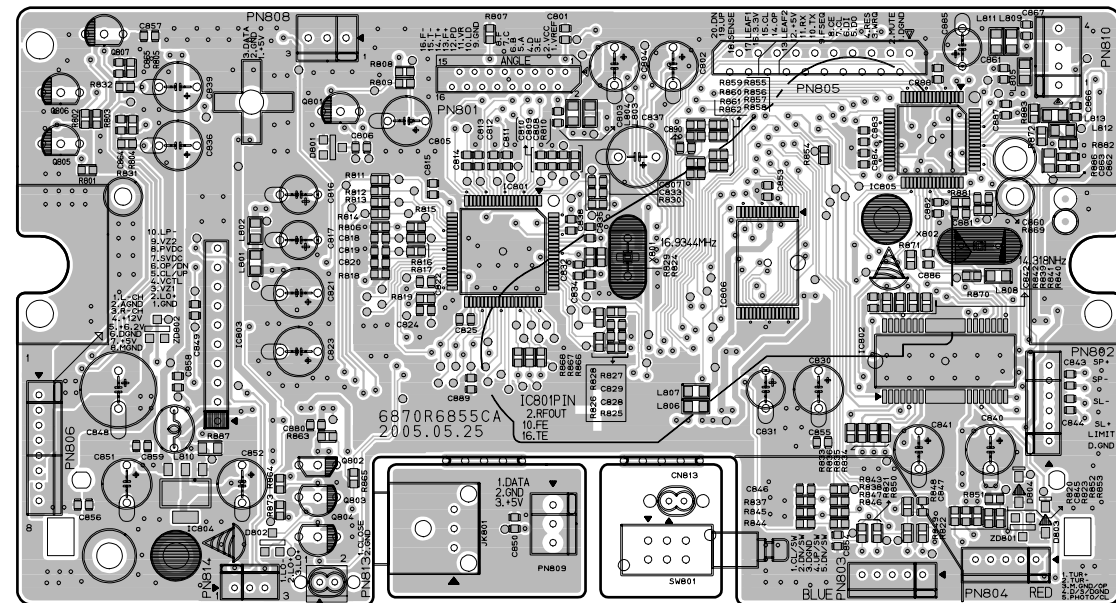

• CD P.C. BOARD (SOLDER SIDE)

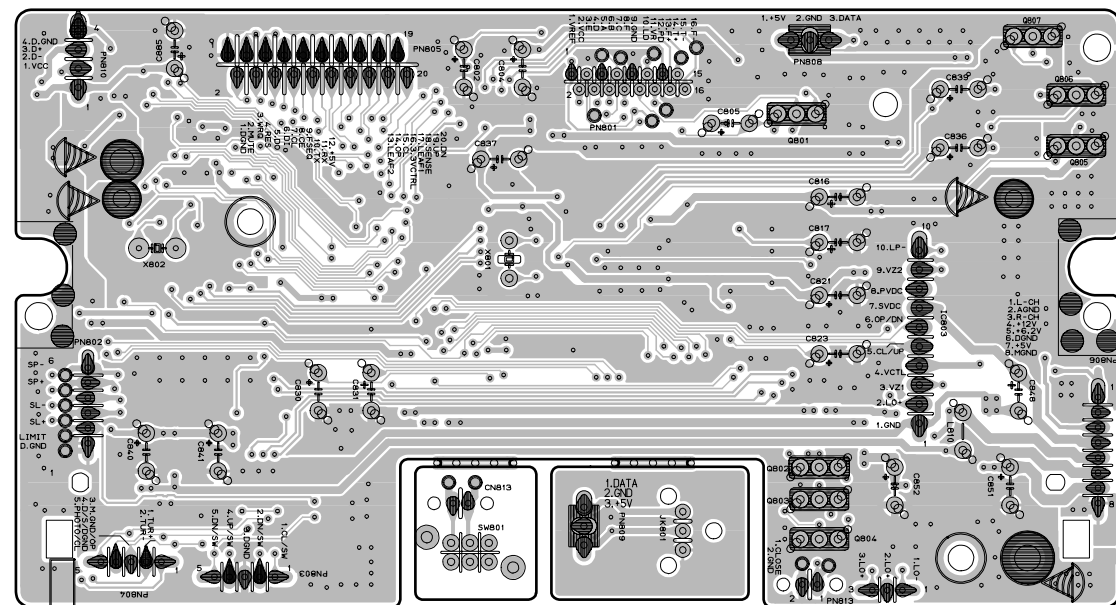

MEMO

Lined area for writing on the left page.

MEMO

Lined area for writing on the right page.

SECTION 3. EXPLODED VIEWS

• CABINET AND MAIN FRAME SECTION

NOTE) Refer to "SECTION 6 REPLACEMENT PARTS LIST" in order to look for the part number of each part.

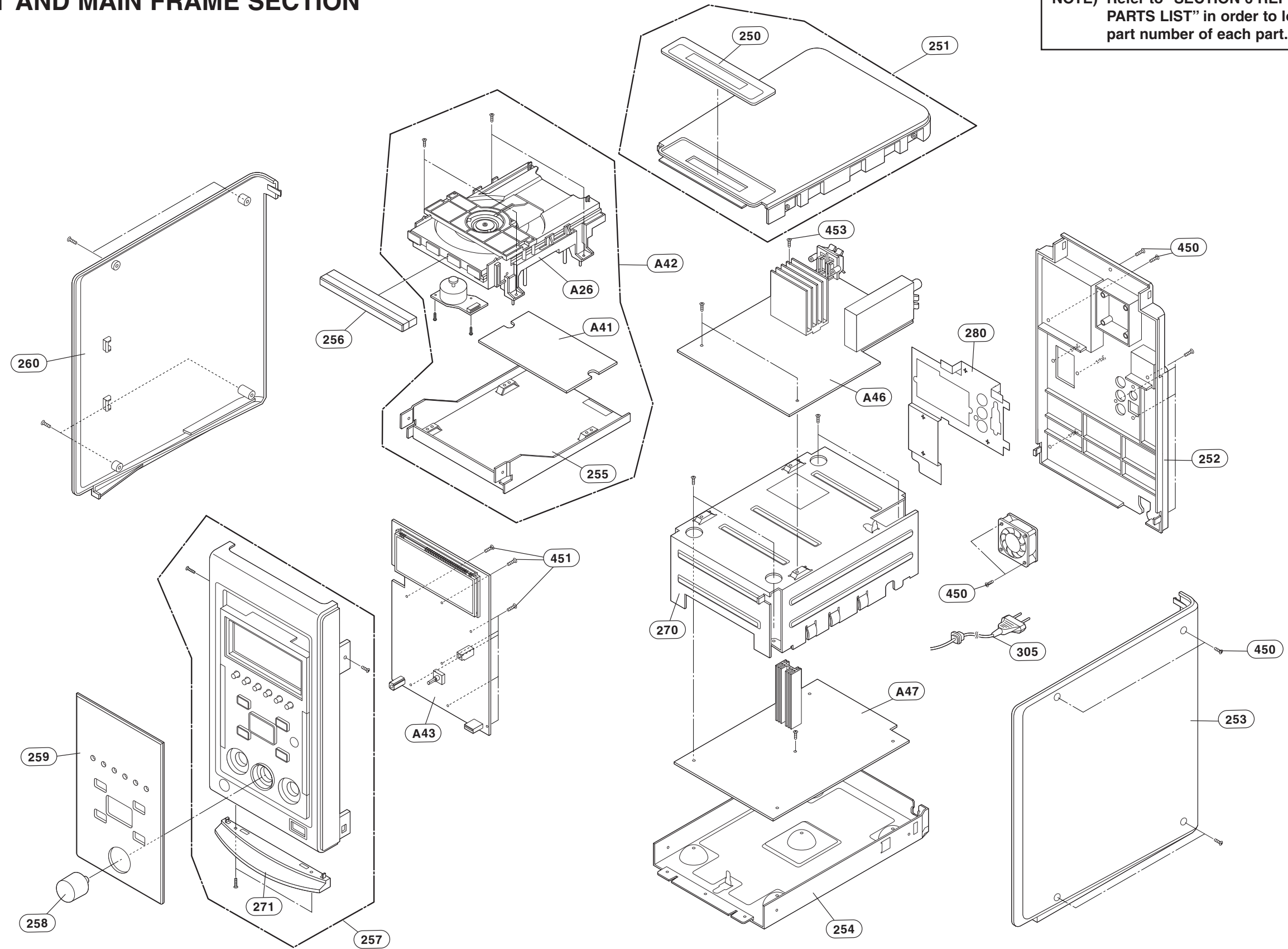

• DECK MECHANISM EXPLODED VIEW

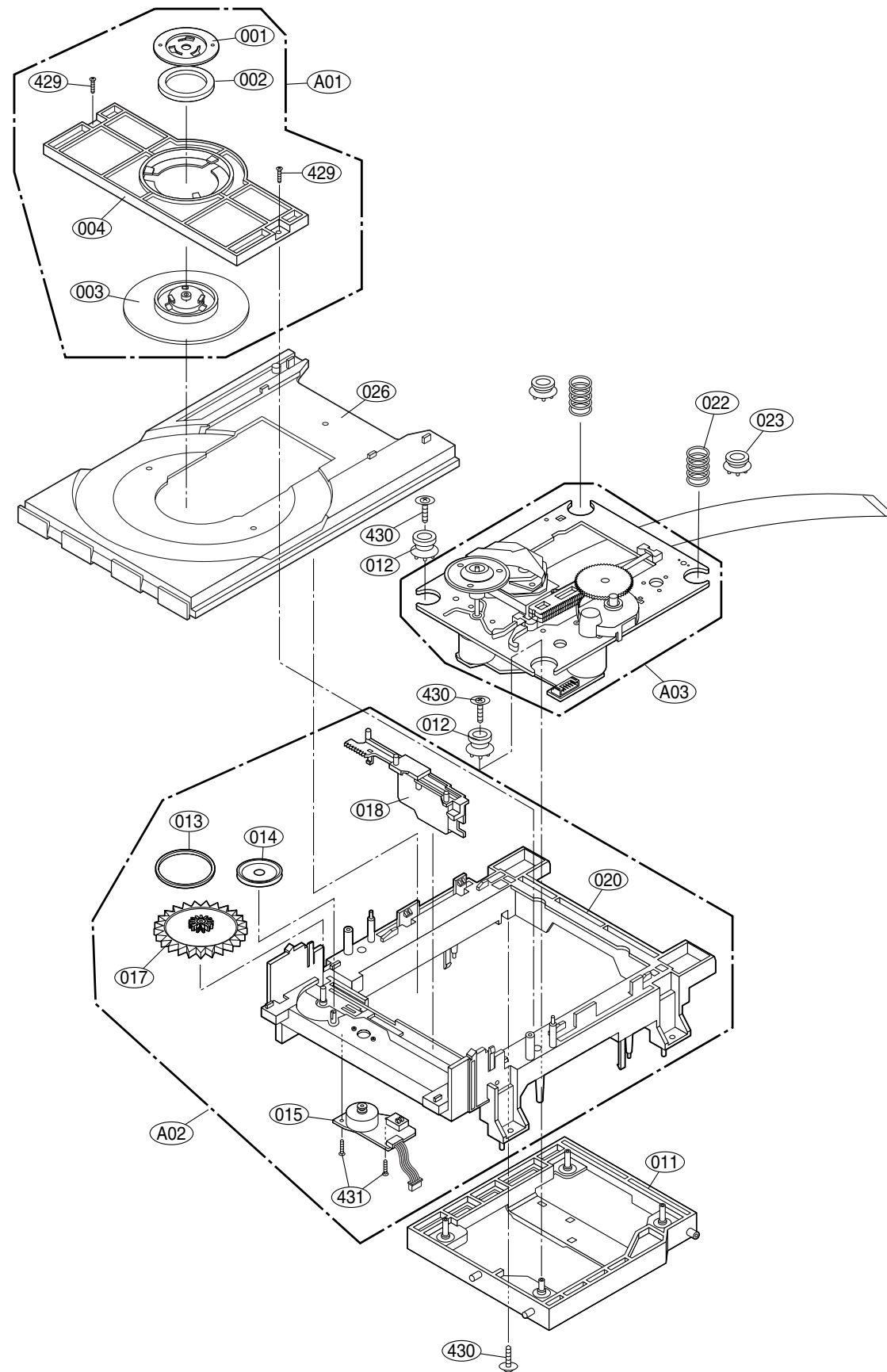

LOCA. NO.	LG PART NO.	DESCRIPTION	SPECIFICATION
A26	6721RJ0572A	DECK ASSEMBLY,AUDIO	HOME LF-U850-HZ-(74.8MM) - SPR
A01	4860RB0003A	CLAMP	HOME CDM-320 MOLD CLAMP ASSY
A02	4405RCD002A	MECHANISM ASSEMBLY	MAIN LOADING CDM-310 CDP
A03	6717R-A002A	PICK UP ASSEMBLY	CMS-D77SG6 SAMSUNG FRONT LOADI
001	3550SB0001A	COVER	HOME PLATE PRESS (CDM-H1303)
002	524-012AAAA	COVER	HOME CLAMP MAGNET OTHER (030X
003	4860RB0002A	CLAMP	HOME CDM-H1503 MOLD DISC
004	4930R-0526A	HOLDER	HOME CDM-310 MOLD CLAMP
011	3040R-0073A	BASE	P/U (CDM-300)
012	5040R-0131A	RUBBER	HOME CDM-310 OTHER DAMPER
013	4400R-0006B	BELT	DECK/MECHA DP2-5, DP7C,DP7A OT
014	4470R-0055A	GEAR	PULLEY
015	6871RC2016A	PWB(PCB) ASSEMBLY,CD	LOADING (CDM-300)
017	4470R-0056A	GEAR	LOADING
018	4974R-0023A	GUIDE	UP/DOWN
020	3040R-M059A	BASE	MAIN CDM-310 MOLD
022	4970RB0001C	SPRING	COIL REAR-25GRAM- 1 CD-(LF-U85
023	4900RB0002A	DAMPER	HOME 3CD CHANGER MOLD RUBBER
026	3390R-0028A	TRAY	HOME CDM-310 MOLD DISC
429	1SZZR-0012A	SCREW,DRAWING	B-TITE
430	6756SBX001A	CD MECHANISM PARTS	SCREW 2.6X10X10XFZMY CDM-H813
431	1SZZH-1007B	SCREW,DRAWING	+ D2.0 6MM SWRCH16A/ZNBK 4MM 1

SECTION 4. SPEAKER PART

□ MODEL: LFS-U850

