



P/NO : 3829RGP015N

DECEMBER, 2004

LG Electronics Inc.

MODELS : LH-CX245(LH-CX245X)/LH-CX246(LH-CX246X)/LH-CX247(LH-CX247X)/LH-CX640(LH-CX640X)

SERVICE MANUAL



DVD/VCR COMBI RECEIVER Combi Receiver System SERVICE MANUAL

MODELS : LH-CX245(LH-CX245X)/LH-CX246(LH-CX246X)
LH-CX247(LH-CX247X)/LH-CX640(LH-CX640X)

CAUTION

BEFORE SERVICING THE UNIT, READ THE "SAFETY PRECAUTIONS"
IN THIS MANUAL.

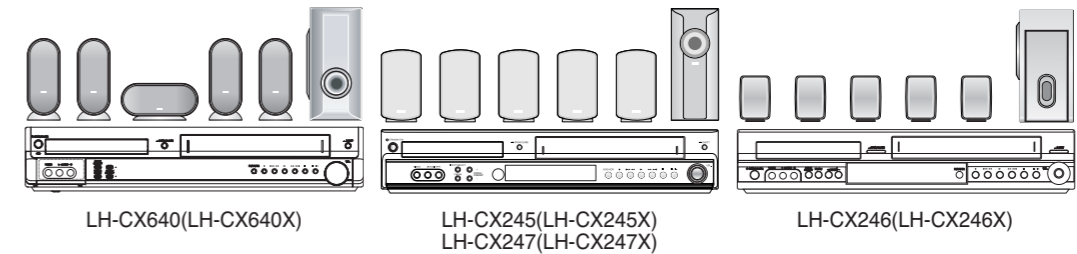

CONTENTS

SECTION 1	SUMMARY
SECTION 2	CABINET & MAIN CHASSIS
SECTION 3	ELECTRICAL
SECTION 4	MECHANISM OF VCR PART
SECTION 5	MECHANISM OF DVD PART
SECTION 6	REPLACEMENT PARTS LIST

SECTION 1

SUMMARY

CONTENTS

PRODUCT SAFETY SERVICING GUIDELINES FOR VIDEO PRODUCTS	1-3
SERVICING PRECAUTIONS	1-4
• General Servicing Precautions	
• Insulation Checking Prodedure	
• Electrostatically Sensitive Devices	
SERVICE INFORMATION FOR EEPROM IC SETTING(VCR).....	1-5
SERVICE INFORMATION FOR EEPROM (DVD).....	1-6
SPECIFICATIONS	1-7

PRODUCT SAFETY SERVICING GUIDELINES FOR VIDEO PRODUCTS

IMPORTANT SAFETY NOTICE

This manual was prepared for use only by properly trained audio-video service technicians.

When servicing this product, under no circumstances should the original design be modified or altered without permission from LG Electronics Corporation. All components should be replaced only with types identical to those in the original circuit and their physical location, wiring and lead dress must conform to original layout upon completion of repairs.

Special components are also used to prevent x-radiation, shock and fire hazard. These components are indicated by the letter "x" included in their component designators and are required to maintain safe performance. No deviations are allowed without prior approval by LG Electronics Corporation.

Circuit diagrams may occasionally differ from the actual circuit used. This way, implementation of the latest safety and performance improvement changes into the set is not delayed until the new service literature is printed.

CAUTION: Do not attempt to modify this product in any way. Never perform customized installations without manufacturer's approval. Unauthorized modifications will not only void the warranty, but may lead to property damage or user injury.

Service work should be performed only after you are thoroughly familiar with these safety checks and servicing guidelines.

GRAPHIC SYMBOLS



The exclamation point within an equilateral triangle is intended to alert the service personnel to important safety information in the service literature.



The lightning flash with arrowhead symbol within an equilateral triangle is intended to alert the service personnel to the presence of noninsulated "dangerous voltage" that may be of sufficient magnitude to constitute a risk of electric shock.



The pictorial representation of a fuse and its rating within an equilateral triangle is intended to convey to the service personnel the following fuse replacement caution notice:

CAUTION: FOR CONTINUED PROTECTION AGAINST RISK OF FIRE, REPLACE ALL FUSES WITH THE SAME TYPE AND RATING AS MARKED NEAR EACH FUSE.

SERVICE INFORMATION

While servicing, use an isolation transformer for protection from AC line shock. After the original service problem has been corrected, make a check of the following:

FIRE AND SHOCK HAZARD

1. Be sure that all components are positioned to avoid a possibility of adjacent component shorts. This is especially important on items transported to and from the repair shop.
2. Verify that all protective devices such as insulators, barriers, covers, shields, strain reliefs, power supply cords, and other hardware have been reinstalled per the original design. Be sure that the safety purpose of the polarized line plug has not been defeated.
3. Soldering must be inspected to discover possible cold solder joints, solder splashes, or sharp solder points. Be certain to remove all loose foreign particles.
4. Check for physical evidence of damage or deterioration to parts and components, for frayed leads or damaged insulation (including the AC cord), and replace if necessary.
5. No lead or component should touch a high current device or a resistor rated at 1 watt or more. Lead tension around protruding metal surfaces must be avoided.
6. After reassembly of the set, always perform an AC leakage test on all exposed metallic parts of the cabinet (the channel selector knobs, antenna terminals, handle and screws) to be sure that set is safe to operate without danger of electrical shock. **DO NOT USE A LINE ISOLATION TRANSFORMER DURING THIS TEST.** Use an AC voltmeter having 5000 ohms per volt or more sensitivity in the following manner: Connect a 1500 ohm, 10 watt resistor, paralleled by a .15 mfd 150V AC type capacitor between a known good earth ground water pipe, conduit, etc.) and the exposed metallic parts, one at a time. Measure the AC voltage across the combination of 1500 ohm resistor and .15 mfd capacitor. Reverse the AC plug by using a non-polarized adaptor and repeat AC voltage measurements for each exposed metallic part. Voltage measured must not exceed 0.75 volts RMS. This corresponds to 0.5 milliamp AC. Any value exceeding this limit constitutes a potential shock hazard and must be corrected immediately.

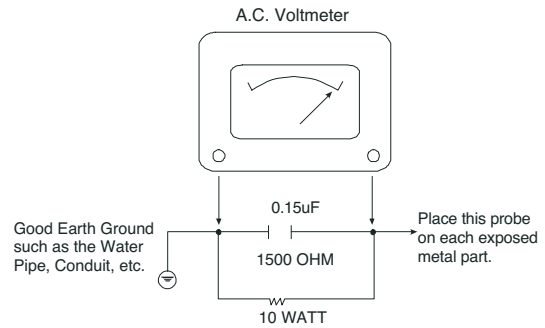

TIPS ON PROPER INSTALLATION

1. Never install any receiver in a closed-in recess, cubbyhole, or closely fitting shelf space over, or close to, a heat duct, or in the path of heated air flow.
2. Avoid conditions of high humidity such as: outdoor patio installations where dew is a factor, near steam radiators where steam leakage is a factor, etc.
3. Avoid placement where draperies may obstruct venting. The customer should also avoid the use of decorative scarves or other coverings that might obstruct ventilation.
4. Wall- and shelf-mounted installations using a commercial mounting kit must follow the factory-approved mounting instructions. A product mounted to a shelf or platform must retain its original feet (or the equivalent thickness in spacers) to provide adequate air flow across the bottom. Bolts or screws used for fasteners must not touch any parts or wiring. Perform leakage tests on customized installations.
5. Caution customers against mounting a product on a sloping shelf or in a tilted position, unless the receiver is properly secured.
6. A product on a roll-about cart should be stable in its mounting to the cart. Caution the customer on the hazards of trying to roll a cart with small casters across thresholds or deep pile carpets.
7. Caution customers against using extension cords. Explain that a forest of extensions, sprouting from a single outlet, can lead to disastrous consequences to home and family.

SERVICING PRECAUTIONS

CAUTION: Before servicing the HOME THEATER COMBI covered by this service data and its supplements and addends, read and follow the SAFETY PRECAUTIONS. **NOTE:** if unforeseen circumstances create conflict between the following servicing precautions and any of the safety precautions in this publications, always follow the safety precautions.

Remember Safety First:

General Servicing Precautions

1. Always unplug the HOME THEATER COMBI AC power cord from the AC power source before:
 - (1) Removing or reinstalling any component, circuit board, module, or any other assembly.
 - (2) Disconnecting or reconnecting any internal electrical plug or other electrical connection.
 - (3) Connecting a test substitute in parallel with an electrolytic capacitor.
Caution: A wrong part substitution or incorrect polarity installation of electrolytic capacitors may result in an explosion hazard.
2. Do not spray chemicals on or near this HOME THEATER COMBI or any of its assemblies.
3. Unless specified otherwise in this service data, clean electrical contacts by applying an appropriate contact cleaning solution to the contacts with a pipe cleaner, cotton-tipped swab, or comparable soft applicator. Unless specified otherwise in this service data, lubrication of contacts is not required.
4. Do not defeat any plug/socket B+ voltage interlocks with which instruments covered by this service manual might be equipped.
5. Do not apply AC power to this HOME THEATER COMBI and/or any of its electrical assemblies unless all solid-state device heat sinks are correctly installed.
6. Always connect the test instrument ground lead to an appropriate ground before connecting the test instrument positive lead. Always remove the test instrument ground lead last.

Insulation Checking Procedure

Disconnect the attachment plug from the AC outlet and turn the power on. Connect an insulation resistance meter (500V) to the blades of the attachment plug. The insulation resistance between each blade of the attachment plug and accessible conductive parts (Note 1) should be more than 1M-ohm.

Note 1: Accessible Conductive Parts include Metal panels, Input terminals, Earphone jacks, etc.

Electrostatically Sensitive (ES) Devices

Some semiconductor (solid state) devices can be damaged easily by static electricity. Such components commonly are called Electrostatically Sensitive (ES) Devices. Examples of typical ES devices are integrated circuits and some field effect transistors and semiconductor chip components.

The following techniques should be used to help reduce the incidence of component damage caused by static electricity.

1. Immediately before handling any semiconductor component or semiconductor-equipped assembly, drain off any electrostatic charge on your body by touching a known earth ground. Alternatively, obtain and wear a commercially available discharging wrist strap device, which should be removed for potential shock reasons prior to applying power to the unit under test.
2. After removing an electrical assembly equipped with ES devices, place the assembly on a conductive surface such as aluminum foil, to prevent electrostatic charge buildup or exposure of the assembly.
3. Use only a grounded-tip soldering iron to solder or unsolder ES devices.
4. Use only an anti-static solder removal device. Some solder removal devices not classified as "anti-static" can generate electrical charges sufficient to damage ES devices.
5. Do not use freon-propelled chemicals. These can generate an electrical charge sufficient to damage ES devices.
6. Do not remove a replacement ES device from its protective package until immediately before you are ready to install it. (Most replacement ES devices are packaged with leads electrically shorted together by conductive foam, aluminum foil, or comparable conductive material).
7. Immediately before removing the protective material from the leads of a replacement ES device, touch the protective material to the chassis or circuit assembly into which the device will be installed.

Caution: Be sure no power is applied to the chassis or circuit, and observe all other safety precautions.

8. Minimize bodily motions when handling unpackaged replacement ES devices. (Normally harmless motion such as the brushing together of your clothes fabric or the lifting of your foot from a carpeted floor can generate static electricity sufficient to damage an ES device.)

SERVICE INFORMATION FOR EEPROM IC SETTING(VCR)

EEPROM option code No. setting				EEPROM option code No. setting procedure																																																																														
<table style="width: 100%; border-collapse: collapse;"> <thead> <tr> <th style="text-align: left;">NAME</th> <th style="text-align: left;">HEX</th> <th style="text-align: left;">BINARY</th> </tr> </thead> <tbody> <tr><td>OPT1</td><td>00</td><td>00000000</td></tr> <tr><td>OPT2</td><td>00</td><td>00000000</td></tr> <tr><td>OPT3</td><td>00</td><td>00000000</td></tr> <tr><td>OPT4</td><td>00</td><td>00000000</td></tr> <tr><td>OPT5</td><td>00</td><td>00000000</td></tr> <tr><td>OPT6</td><td>00</td><td>00000000</td></tr> </tbody> </table> <p style="margin-top: 10px;"> WR : OK I : EXIT MOVE : ◀ ▶ EDIT : ▲ ▼ MASKROM : R00 EEPROM : R00 LG CODE </p>	NAME	HEX	BINARY	OPT1	00	00000000	OPT2	00	00000000	OPT3	00	00000000	OPT4	00	00000000	OPT5	00	00000000	OPT6	00	00000000	➔	<ol style="list-style-type: none"> 1. DETECT NEW EEPROM (OPTION EDIT SCREEN) <ul style="list-style-type: none"> - Eeprom EDIT screen automatically appears if replacing Eeprom. - Setup option data using the cursor Up/Down key of a remote control. (Setup upon BOM depending on OPT1~OPT6 model) • Since an initial remote control is set to LG for LG model, appropriately set optiona data using the cursor Up/Down key. 																																																											
NAME	HEX	BINARY																																																																																
OPT1	00	00000000																																																																																
OPT2	00	00000000																																																																																
OPT3	00	00000000																																																																																
OPT4	00	00000000																																																																																
OPT5	00	00000000																																																																																
OPT6	00	00000000																																																																																
<table style="width: 100%; border-collapse: collapse;"> <thead> <tr> <th style="text-align: left;">MODEL</th> <th style="text-align: left;">NAME</th> <th style="text-align: left;">HEX</th> <th style="text-align: left;">BINARY</th> </tr> </thead> <tbody> <tr> <td rowspan="6">LH-CX246</td> <td>OPT1</td><td>38</td><td>00000000</td></tr> <tr><td>OPT2</td><td>ED</td><td>00000000</td></tr> <tr><td>OPT3</td><td>20</td><td>00000000</td></tr> <tr><td>OPT4</td><td>8A</td><td>00000000</td></tr> <tr><td>OPT5</td><td>41</td><td>00000000</td></tr> <tr><td>OPT6</td><td>AF</td><td>00000000</td></tr> <tr> <td rowspan="6">LH-CX245</td> <td>OPT1</td><td>38</td><td>00000000</td></tr> <tr><td>OPT2</td><td>ED</td><td>00000000</td></tr> <tr><td>OPT3</td><td>20</td><td>00000000</td></tr> <tr><td>OPT4</td><td>8A</td><td>00000000</td></tr> <tr><td>OPT5</td><td>41</td><td>00000000</td></tr> <tr><td>OPT6</td><td>AF</td><td>00000000</td></tr> <tr> <td rowspan="6">LH-CX247</td> <td>OPT1</td><td>38</td><td>00000000</td></tr> <tr><td>OPT2</td><td>ED</td><td>00000000</td></tr> <tr><td>OPT3</td><td>20</td><td>00000000</td></tr> <tr><td>OPT4</td><td>8A</td><td>00000000</td></tr> <tr><td>OPT5</td><td>41</td><td>00000000</td></tr> <tr><td>OPT6</td><td>AF</td><td>00000000</td></tr> <tr> <td rowspan="6">LH-CX640</td> <td>OPT1</td><td>38</td><td>00000000</td></tr> <tr><td>OPT2</td><td>ED</td><td>00000000</td></tr> <tr><td>OPT3</td><td>A0</td><td>00000000</td></tr> <tr><td>OPT4</td><td>8A</td><td>00000000</td></tr> <tr><td>OPT5</td><td>61</td><td>00000000</td></tr> <tr><td>OPT6</td><td>AF</td><td>00000000</td></tr> </tbody> </table> <p style="margin-top: 10px;"> WR : OK I : EXIT MOVE : ◀ ▶ EDIT : ▲ ▼ </p>	MODEL	NAME	HEX	BINARY	LH-CX246	OPT1	38	00000000	OPT2	ED	00000000	OPT3	20	00000000	OPT4	8A	00000000	OPT5	41	00000000	OPT6	AF	00000000	LH-CX245	OPT1	38	00000000	OPT2	ED	00000000	OPT3	20	00000000	OPT4	8A	00000000	OPT5	41	00000000	OPT6	AF	00000000	LH-CX247	OPT1	38	00000000	OPT2	ED	00000000	OPT3	20	00000000	OPT4	8A	00000000	OPT5	41	00000000	OPT6	AF	00000000	LH-CX640	OPT1	38	00000000	OPT2	ED	00000000	OPT3	A0	00000000	OPT4	8A	00000000	OPT5	61	00000000	OPT6	AF	00000000	➔	<ol style="list-style-type: none"> 2. EEPROM WRITED COMPLETE SCREEN <ul style="list-style-type: none"> - Writes data on EEPROM by using REMOCON "OK". - If completing the option data screen with a menu key, Powering Off is automatically done and the option edit screen is arranged. 3. PG ADJUST <ul style="list-style-type: none"> - Plays PAL SP TAPE for adjusting the AUTO PG. - A 0:00:00 is played in the field if pressing the front play with Remocon number "1" key played during PAL SP. - The 0:00:00 in the field represents position of the TRACKING PRESET. - "OFF" is displayed in the field if pressing the front play key with the remocon number "1" in the status of the tracking preset pressed, and "ON" is displayed in the field if AUTO PG operation is automatically performed and completed. - DECK STOP > plays if above operation is completed. Set operation is performed depending on changed PG values. These values are stored in the EEPROM area. 4. EEPROM INITIAL <ul style="list-style-type: none"> - SETUP is displayed in the field if pressing the FRONT REC KEY with the remocon number "CLEAR" key pressed in the status of powering Off. - AUTO SEARCH is done since the initial screen of ACMS is serviced if powering On. - Check basic operation (PLAY/RECORD...)
MODEL	NAME	HEX	BINARY																																																																															
LH-CX246	OPT1	38	00000000																																																																															
	OPT2	ED	00000000																																																																															
	OPT3	20	00000000																																																																															
	OPT4	8A	00000000																																																																															
	OPT5	41	00000000																																																																															
	OPT6	AF	00000000																																																																															
LH-CX245	OPT1	38	00000000																																																																															
	OPT2	ED	00000000																																																																															
	OPT3	20	00000000																																																																															
	OPT4	8A	00000000																																																																															
	OPT5	41	00000000																																																																															
	OPT6	AF	00000000																																																																															
LH-CX247	OPT1	38	00000000																																																																															
	OPT2	ED	00000000																																																																															
	OPT3	20	00000000																																																																															
	OPT4	8A	00000000																																																																															
	OPT5	41	00000000																																																																															
	OPT6	AF	00000000																																																																															
LH-CX640	OPT1	38	00000000																																																																															
	OPT2	ED	00000000																																																																															
	OPT3	A0	00000000																																																																															
	OPT4	8A	00000000																																																																															
	OPT5	61	00000000																																																																															
	OPT6	AF	00000000																																																																															

SERVICE INFORMATION FOR EEPROM (DVD)

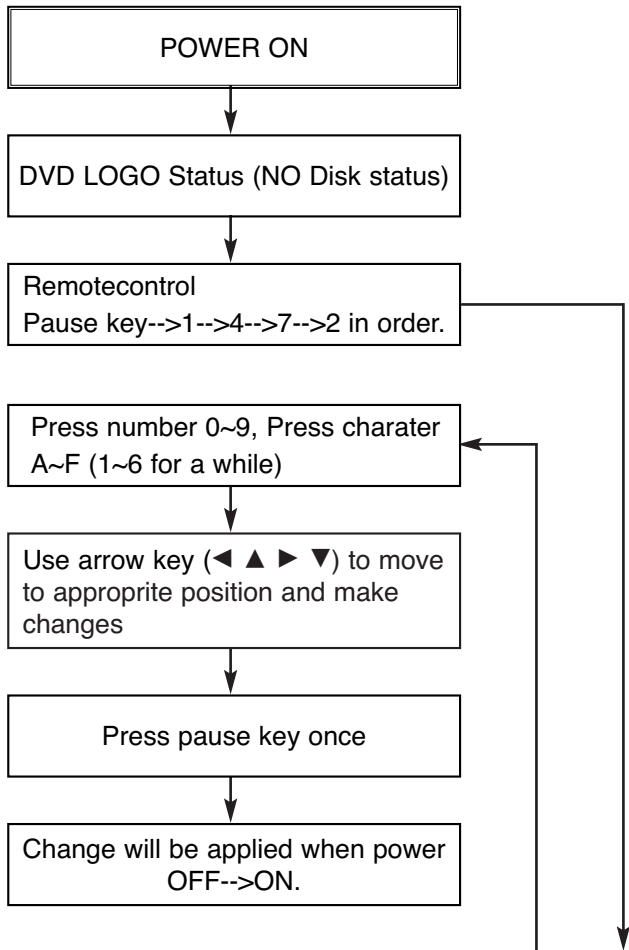

DETECT NEW EEPROM (OPTION EDIT SCREEN)

NAME MODEL	OPT 1	OPT 2	OPT 3	OPT 4	OPT 5	OPT 6	OPT 7	OPT 8	OPT 9	OPT A	OPT B	OPT C	OPT D	OPT E	OPT F	OPT G
LH-CX245	00	F7	87	05	FC	22	00	00	00	0A	00	00	00	00	00	00
LH-CX246	00	F7	87	05	FC	22	00	00	00	0A	00	00	00	00	00	00
LH-CX247	00	F7	87	05	FC	22	00	00	00	0A	00	00	00	00	00	00
LH-CX640	00	F7	87	05	FC	A2	00	00	00	00	00	00	00	00	00	00

* OPTION

- NTSC model doesn't have VCR option and use DVD option B~F as VCR option. (only DVD exist)
- PAL model has another separate VCR option. (Both VCR and DVD exist)

SPECIFICATIONS

General

Power requirements	Refer to main label
Power consumption	Refer to main label
Dimensions (approx.)	430 X 81 X 360 mm (w/h/d)
Mass (approx.)	5.8 kg
Operating temperature	5°C to 40°C (41°F to 95°F)
Operating humidity	5 % to 90 %
Timer	24 hours display tape

DVD Section

Laser	Semiconductor laser, wavelength 650 nm
Signal system	PAL/NTSC
Frequency response	DVD (PCM 96 kHz): 8 Hz to 44 kHz DVD (PCM 48 kHz): 8 Hz to 20 kHz CD: 8 Hz to 20 kHz
Signal-to-noise ratio	More than 70 dB (analog out connectors only)
Harmonic distortion	Less than 1.0%
Dynamic range	More than 60 dB (DVD, CD)

Outputs

S-VIDEO OUT	(Y) 1.0 V (p-p), 75 ohms, negative sync, Mini DIN 4-pin x 1 (C) 0.3 V (p-p) 75 ohms
-------------	--

VCR Section

Tape speed	PAL/MESECAM; 23.39 mm/s (SP), 16.69 mm/s (LP) NTSC (Playback only); 35.35 mm/s (SP), 16.67 mm/s (LP), 11.12 mm/s (EP)
Maximum recording time	SP: 4 h (E-240 tape), LP: 8 h (E-240 tape)
Rewind time	About 180 min (E-180 tape)
Input level	VIDEO: 1.0 V(p-p), 75 ohms, unbalanced AUDIO: -6.0 dBm, more than 10 kohms (SCART) -6.0 dBm, more than 47 kohms (RCA)
Output level	VIDEO: 1.0 V(p-p), 75 ohms, unbalanced
Signal-to-noise ratio	VIDEO: More than 43 dB AUDIO: More than 72 dB (Hi-Fi) More than 42 dB (Mono)
Dynamic range	AUDIO: More than 85 dB

Tuner Section

Tuning range	FM: 87.5 - 108.0 MHz AM: 522 - 1611 kHz
Intermediate frequency	FM: 10.7 MHz AM: 450 kHz

Amplifier(LH-CX245/LH-CX247)

Stereo mode	25W + 25W (6 ohm at 1 kHz, THD 10%)
Surround mode	Front: 25W + 25W (THD 10%) Centre: 25W Surround: 25W + 25W (6 ohm at 1 kHz, THD 10%) Subwoofer: 60W (8 ohm at 30 Hz, THD 10%)

Speaker Section(LH-CX245/LH-CX247)

	Satellite Speaker (LHS-CX245T/LHS-CX247T)	Passive Speaker (LHS-CX245W/LHS-CX247W)
Type	1 Way 1 Speaker	1 Way 1 Speaker
Impedance	8 Ω	8 Ω
Frequency Response	130 - 20,000 Hz	50 - 1,500 Hz
Sound Pressure Level	85 dB/W (1m)	82 dB/W (1m)
Rated Input Power	25W	60W
Max Input Power	50W	120W
Net Dimensions (W x H x D)	90 x 138.5 x 100 mm	160 x 350 x 345 mm
Net Weight	0.9 kg	4.5 kg

Amplifier(LH-CX246)

Stereo mode 25W + 25W (6 ohm at 1 kHz, THD 10%)
Surround mode Front: 25W + 25W (THD 10%)
Centre: 25W
Surround: 25W + 25W (6 ohm at 1 kHz, THD 10%)
Subwoofer: 60W (8 ohm at 30 Hz, THD 10%)

Speaker Section(LH-CX246)

	Satellite Speaker (LHS-CX246T)	Passive Speaker (LHS-CX246W)
Type	1 Way 1 Speaker	1 Way 1 Speaker
Impedance	8 Ω	8 Ω
Frequency Response	130 - 20,000 Hz	50 - 1,500 Hz
Sound Pressure Level	85 dB/W (1m)	82 dB/W (1m)
Rated Input Power	25W	60W
Max Input Power	50W	120W
Net Dimensions (W x H x D)	89 x 130 x 114 mm	160 x 350 x 333 mm
Net Weight	0.54 kg	4.5 kg

Amplifier(LH-CX640)

Stereo mode 90W + 90W (6 ohm at 1 kHz, THD 10%)
Surround mode Front: 90W + 90W (THD 10%)
Centre: 90W
Surround: 90W + 90W (6 ohm at 1 kHz, THD 10%)
Subwoofer: 150W (4 ohm at 30 Hz, THD 10%)

Speaker Section(LH-CX640)

	Satellite Speaker (LHS-CX640T)	Centre speaker (LHS-CX640C)	Passive Subwoofer (LHS-CX640W)
Type	2 Way 2 Speaker	2 Way 2 Speaker	1 Way 1 Speaker
Impedance	6 Ω	6 Ω	4 Ω
Frequency Response	120 - 20,000 Hz	120 - 20,000 Hz	40 - 1,500 Hz
Sound Pressure Level	82 dB/W (1m)	82 dB/W (1m)	83 dB/W (1m)
Rated Input Power	90W	90W	150W
Max Input Power	180W	180W	300W
Net Dimensions (W x H x D)	104 x 233 x 120 mm	220 x 114 x 110 mm	195 x 380 x 419 mm
Net Weight	1.0 kg	1.0 kg	6.6 kg

• Design and specifications are subject to change without notice.

Manufactured under license from Dolby Laboratories. "Dolby" and the double-D symbol are trademarks of Dolby Laboratories. Confidential unpublished works. Copyright 1992-1997 Dolby Laboratories. All rights reserved.

"DTS" and "DTS Digital Surround" are trademarks of Digital Theater Systems, Inc.

SECTION 2

CABINET & MAIN CHASSIS

CONTENTS

EXPLODED VIEWS	2-2
1. Cabinet and Main Frame Section	2-2
2. Woofer Speaker Section (LHS-CX245W/LHS-CX247W)	2-3
3. Woofer Speaker Section (LHS-CX246W)	2-4
4. Woofer Speaker Section (LHS-CX640W)	2-5
5. Setellite & Center Speaker Section (LHS-CX245T/LHS-CX247T)	2-6
6. Setellite & Center Speaker Section (LHS-CX246T).....	2-7
7. Setellite Speaker Section (LHS-CX640T).....	2-8
8. Center Speaker Section (LHS-CX640C).....	2-9
9. Packing Accessory Section.....	2-10

EXPLODED VIEWS

1. Cabinet and Main Frame Section

★ OPTIONAL PARTS

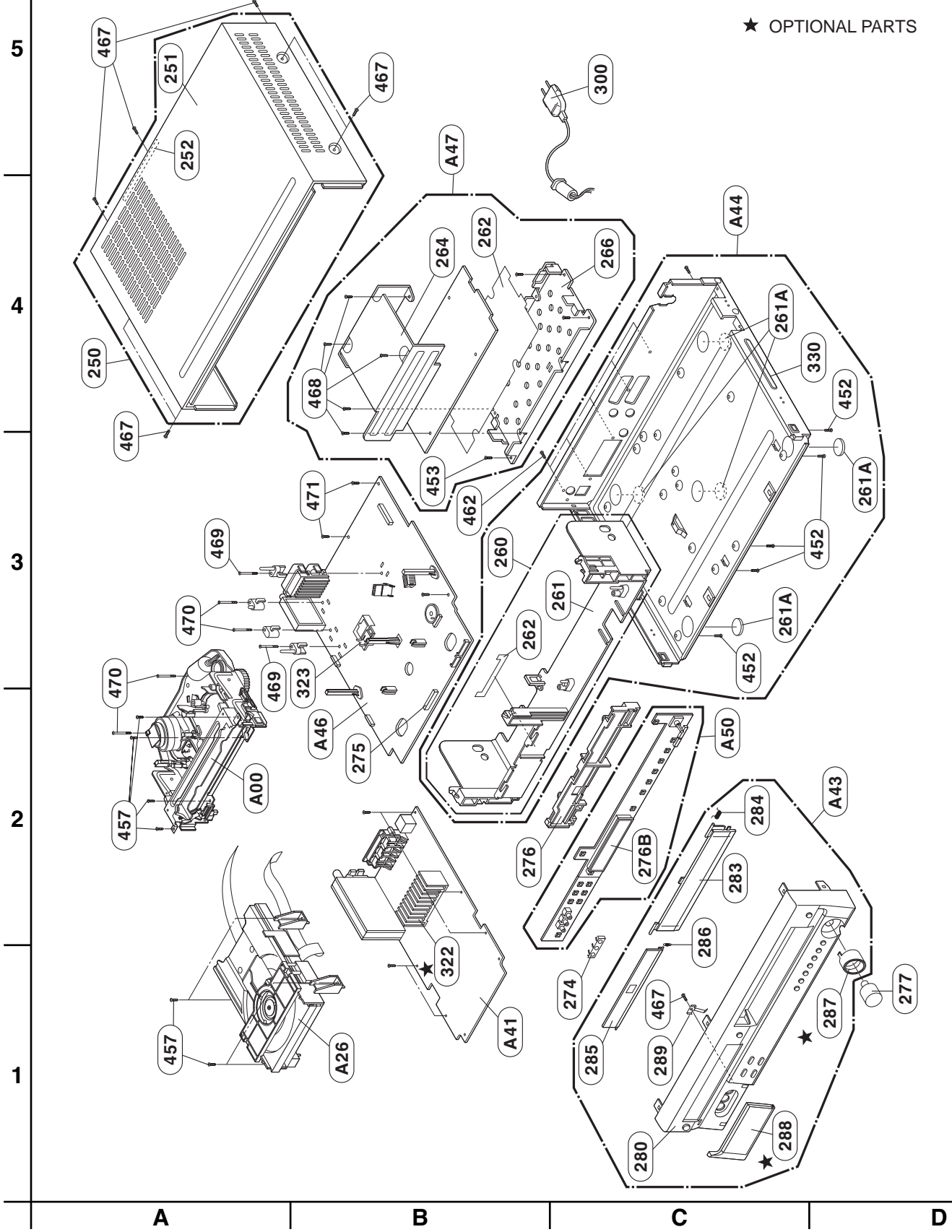

2. Woofer Speaker Section (LHS-CX245W/LHS-CX247W)

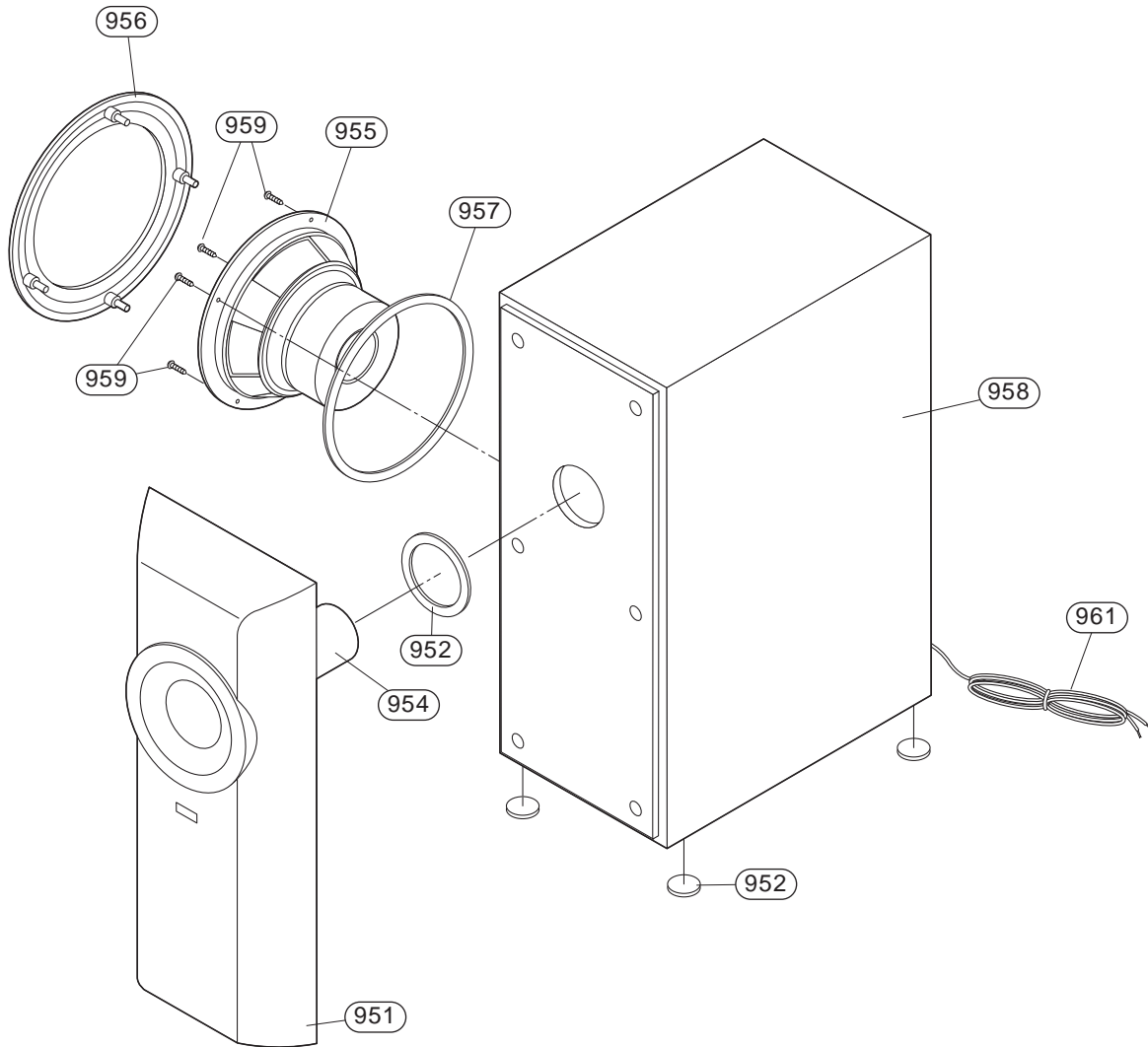

LOCA. NO.	PART NO.	DESCRIPTION	SPECIFICATION
951	3720RMF085A	PANEL,FRONT	SPK LHS-D6245W MOLD STANDARD
952	4766RM0097A	FELT	INSIDE 65 MM, OUTSIDE 85MM,THI
953	3091RMW099A	CABINET ASSEMBLY	SPK LHS-D6245W STANDARD FINE
954	5208RM0056A	DUCT	SPK LHS-D6245W OTHER PAPER PIP
955	6400WTTJ03A	SPEAKER,WOOFER	F65C-D365 TOPTONE WOOFER LHS-6
956	3701RM0104A	NET ASSEMBLY	SPK LHS-D6245W SP-8505
957	4766RM0005A	FELT	Audio WF,FE-3500SW,470X7X1T BL
959	353M050C	SCREW,DRAWING	BH 3.5X16 FBK
960	3610RM0046A	FOOT	SPK LHS-D6245W OTHER FOOT RUBB
961	6871RU9271F	PWB(PCB) ASSEMBLY,SUBSET(AUDIO	LHS-D6230W SUB WOOFER 2.5M, OR

3. Woofer Speaker Section (LHS-CX246W)

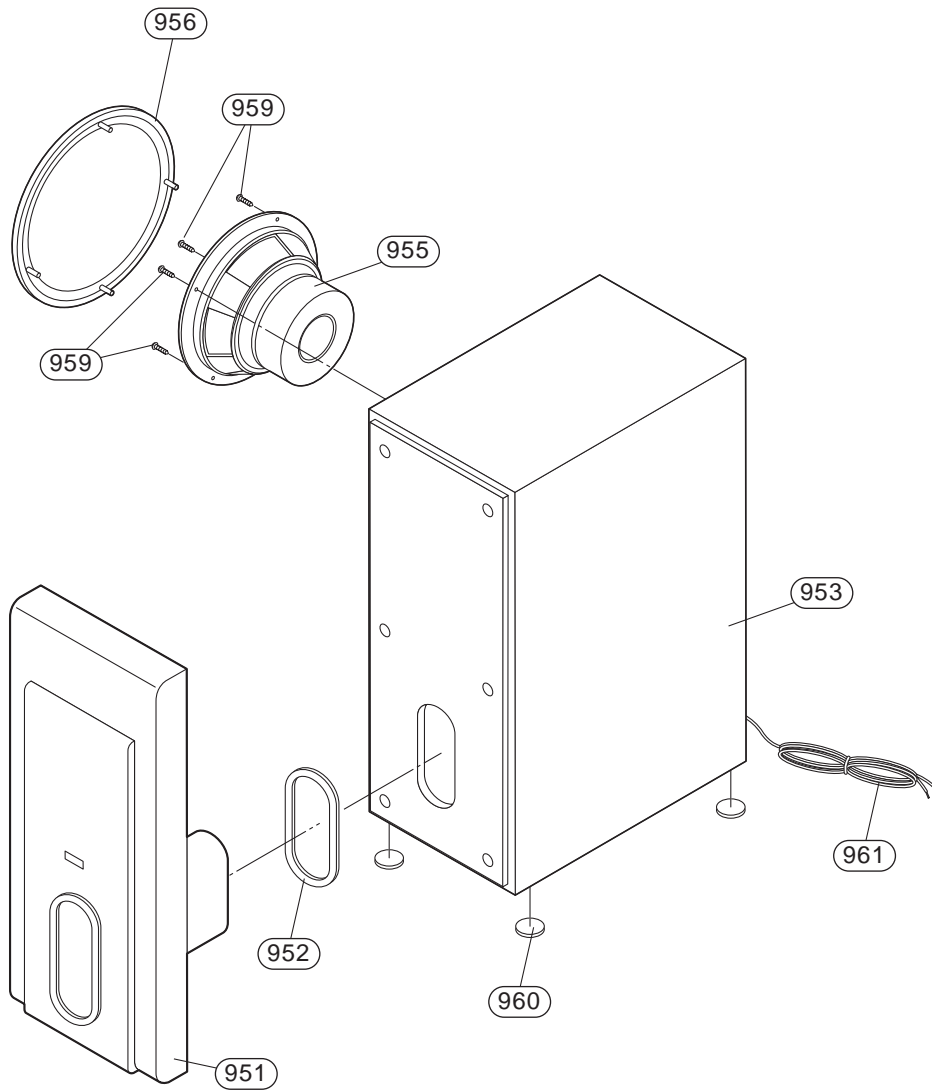

LOCA.NO.	PART NO	DESCRIPTION	SPECIFICATION	REMARKS
951	3720RMF081A	PANEL,FRONT	SPK LHS-D6240W MOLD FRONT PANE	
952	4766RM0084A	FELT	1T BLACK EVA	
953	3091RMW094D	CABINET ASSEMBLY	SPK LHS-D6240W CABINET ASSY	
955	6400WTTJ03A	SPEAKER,WOOFER	CW-165B40L SAMMI WOOFER LHS-D6	
956	4766RM0005A	FELT	Audio WF,FE-3500SW,470X7X1T BL	
959	353M050C	SCREW,DRAWING	BH 3.5X16 FBK	
960	3610RM0024A	FOOT	SPK LMS-230/530 OTHER (EVA) PH	
961	6871RU9271F	PWB(PCB) ASSEMBLY,SUBSET(AUDIO	LHS-D6230W SUB WOOFER 2.5M, OR	

4. Woofer Speaker Section (LHS-CX640W)

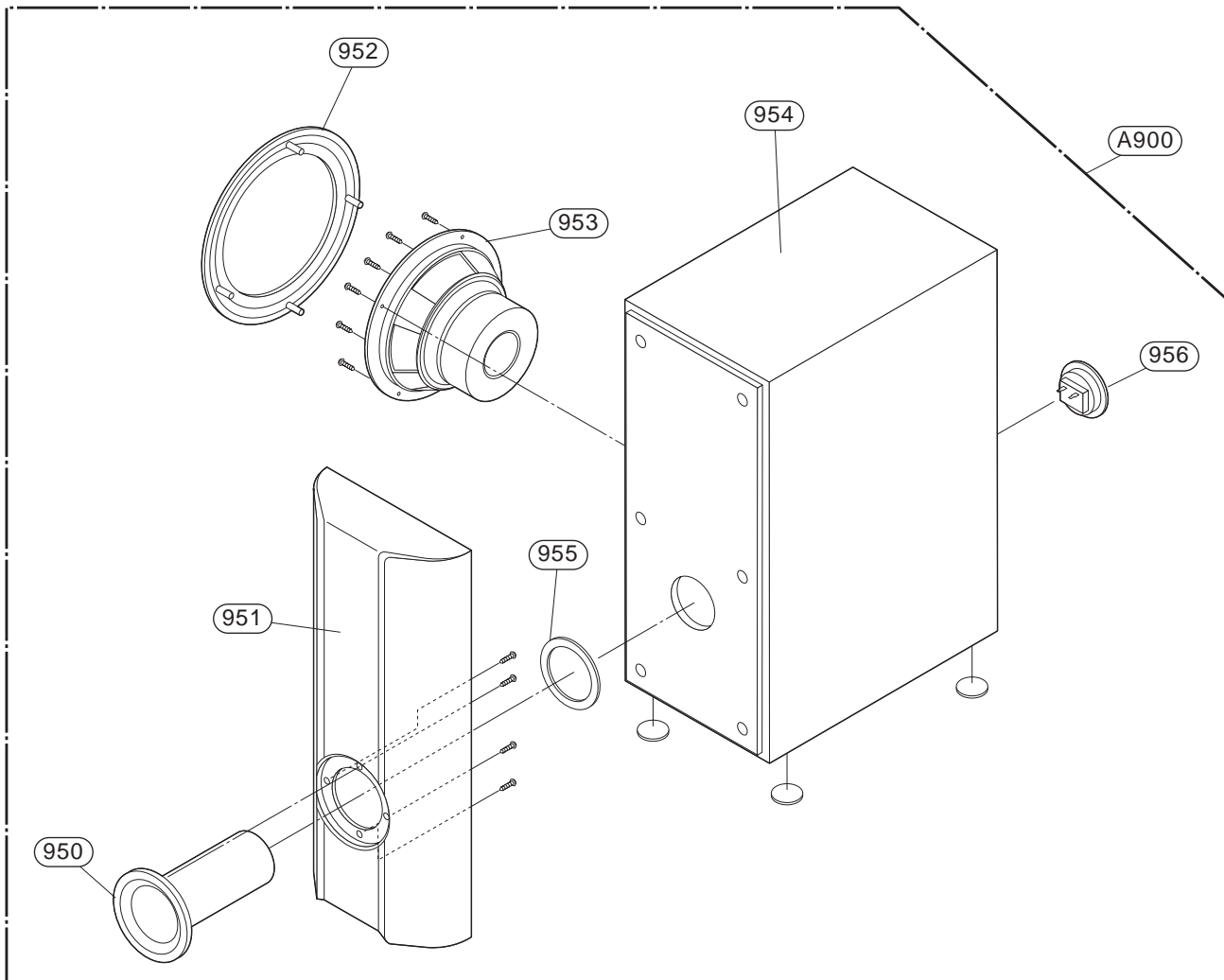

S	AL	LOCA. NO.	PART NO.	DESCRIPTION	SPECIFICATION	REMARKS
		A900	6401RM0160A	SPEAKER ASSEMBLY	CW-210B150L-1 SAMMI LHS-C640W	
		950	5208RM0059A	DUCT	SPK LHS-T6540W MOLD CHROME PLA	
		951	3720RMM013A	PANEL,AUDIO	SPK LHS-T6540W MOLD FRONT (SIL	
		952	3701RM0110A	NET ASSEMBLY	SPK LHS-T6540W NET ASSY	
		953	6400WSMK03A	SPEAKER,WOOFER	CW-210B150L-1 SAMMI WOOFER 4 O	
		954	3091RMW107A	CABINET ASSEMBLY	SPK LHS-T6540W CABINET ASSY	
		955	4766RM0110A	FELT	63*115*2T BLACK DUCT EVA	
		956	6871RU9251A	PWB(PCB) ASSEMBLY,SUBSET(AUDIO	ASSY FE-5000WE ROUND 2P TERMIN	
		957	3610RM0009A	FOOT	LXS-330, EVA(BLACK) PHI15X1T,	

5. Setellite & Center Speaker Section (LHS-CX245T/LHS-CX247T)

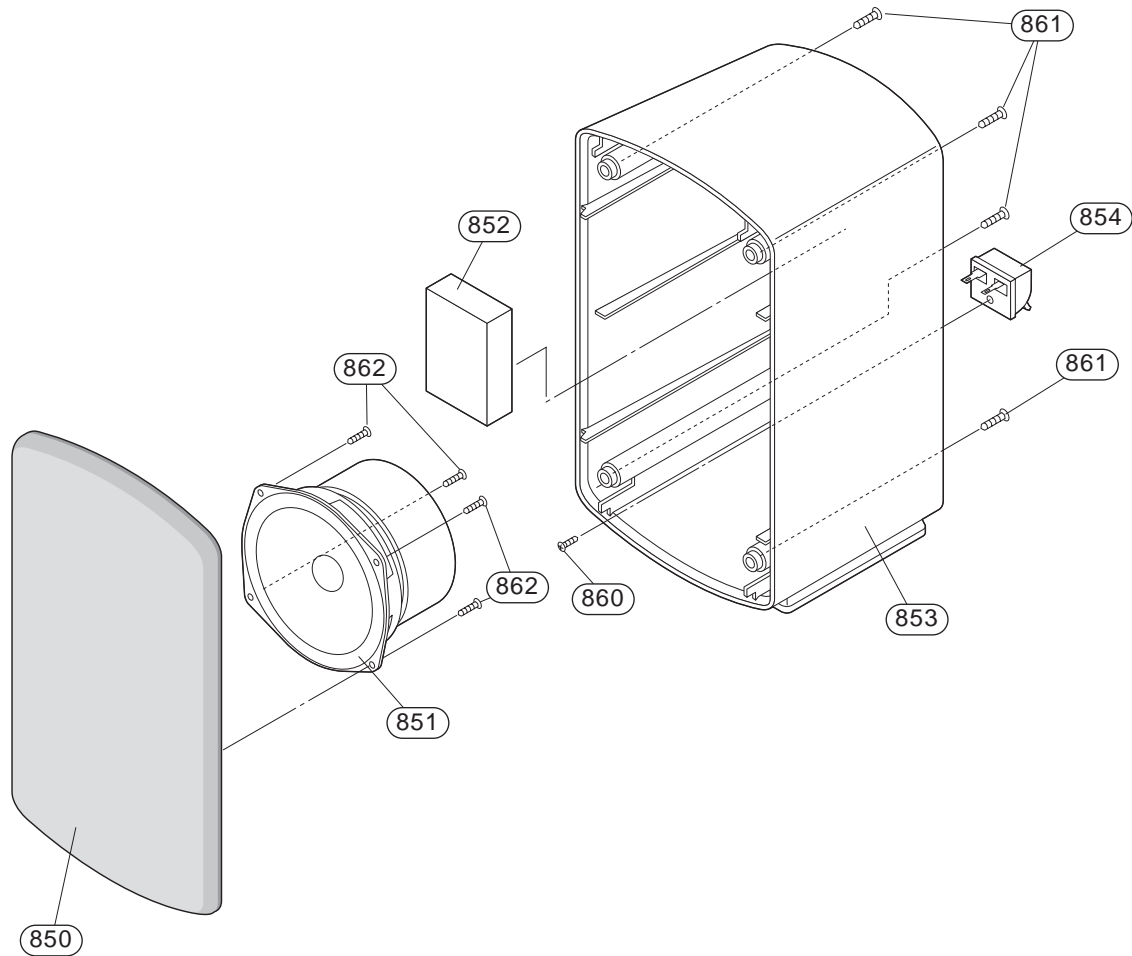

LOCA. NO.	PART NO.	DESCRIPTION	SPECIFICATION
850	3701RM0103A	NET ASSEMBLY	SPK LHS-D6245T SP 8505
851	6400WTTC04A	SPEAKER,FULLRANGE	F30C-D366-2 TOPTONE WOOFER 60H
852	4930RM0025A	HOLDER	AIR COVER LH-6230TE
853	3110RMP044A	CASE	LHS-D6245T MOLD STANDARD
854	6871RU4116B	PWB(PCB) ASSEMBLY,SUBSET(AUDIO)	FE-3620TE 2P NEW TERMINAL 150M
860	353M025C	SCREW,DRAWING	TAPTITE, 3X10 FBK
861	353M025W	SCREW,DRAWING	+ 2 D3.0 L14.0 MSWR3/FZB
862	353M025V	SCREW,DRAWING	+ 2 D3.0 L6.0 MSWR3/FZB

6. Setellite & Center Speaker Section (LHS-CX246T)

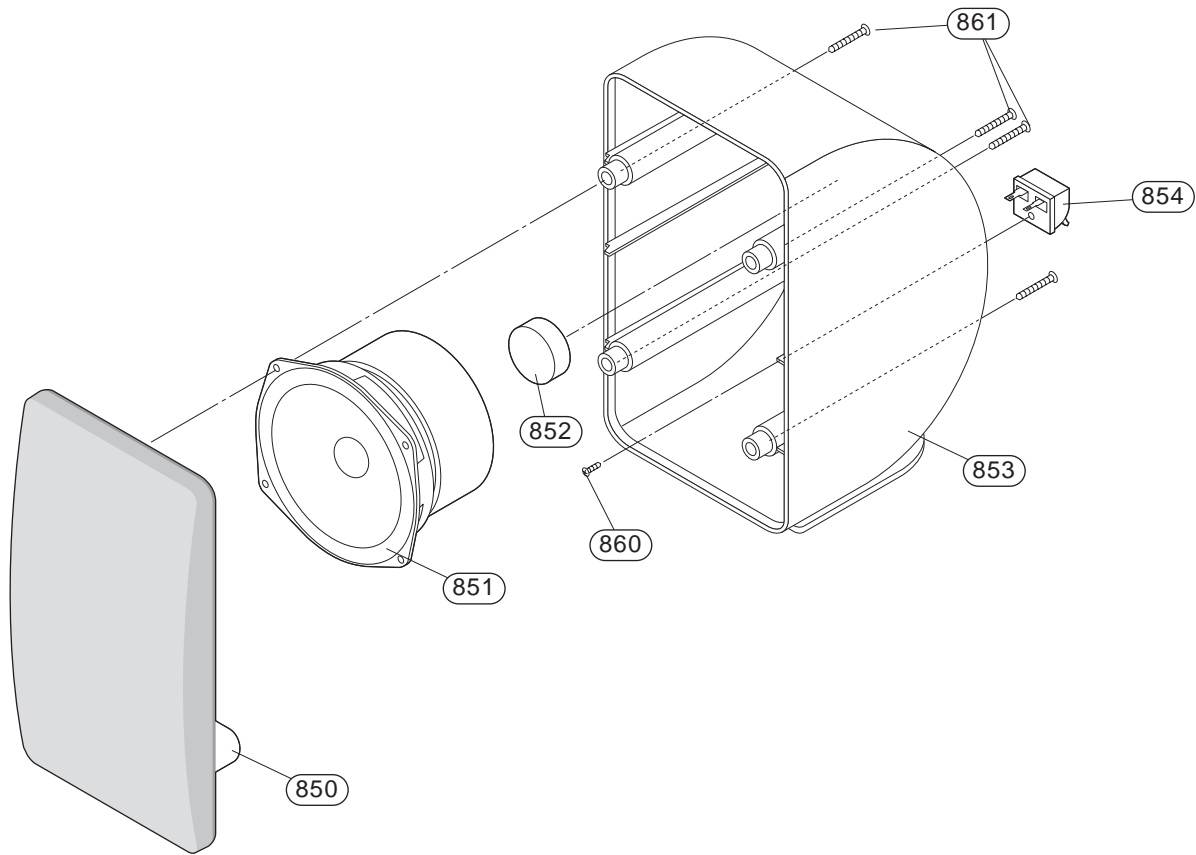

LOCA.NO.	PART NO	DESCRIPTION	SPECIFICATION	REMARKS
850	3701RM0093A	NET ASSEMBLY	SPK LHS-D6240T SP-8505	
851	6400WTTC04A	SPEAKER,WOOFER	MSF-80SB20L-1 SAMMI WOOFER 6OH	
852	4930RM0046A	HOLDER	SPK LHS-D6240T MOLD PREVENTION	
853	3110RMP042A	CASE	LHS-D6240T MOLD REAR CASE	
854	6871RU4116B	PWB(PCB) ASSEMBLY,SUBSET(AUDIO	FE-3620TE 2P NEW TERMINAL 150M	
860	353M025G	SCREW,DRAWING	TAPTITE, 3X10 FZMY	
861	353M025H	SCREW,DRAWING	TAPTITE, 3X16 FZMY	

7. Setellite Speaker Section (LHS-CX640T)

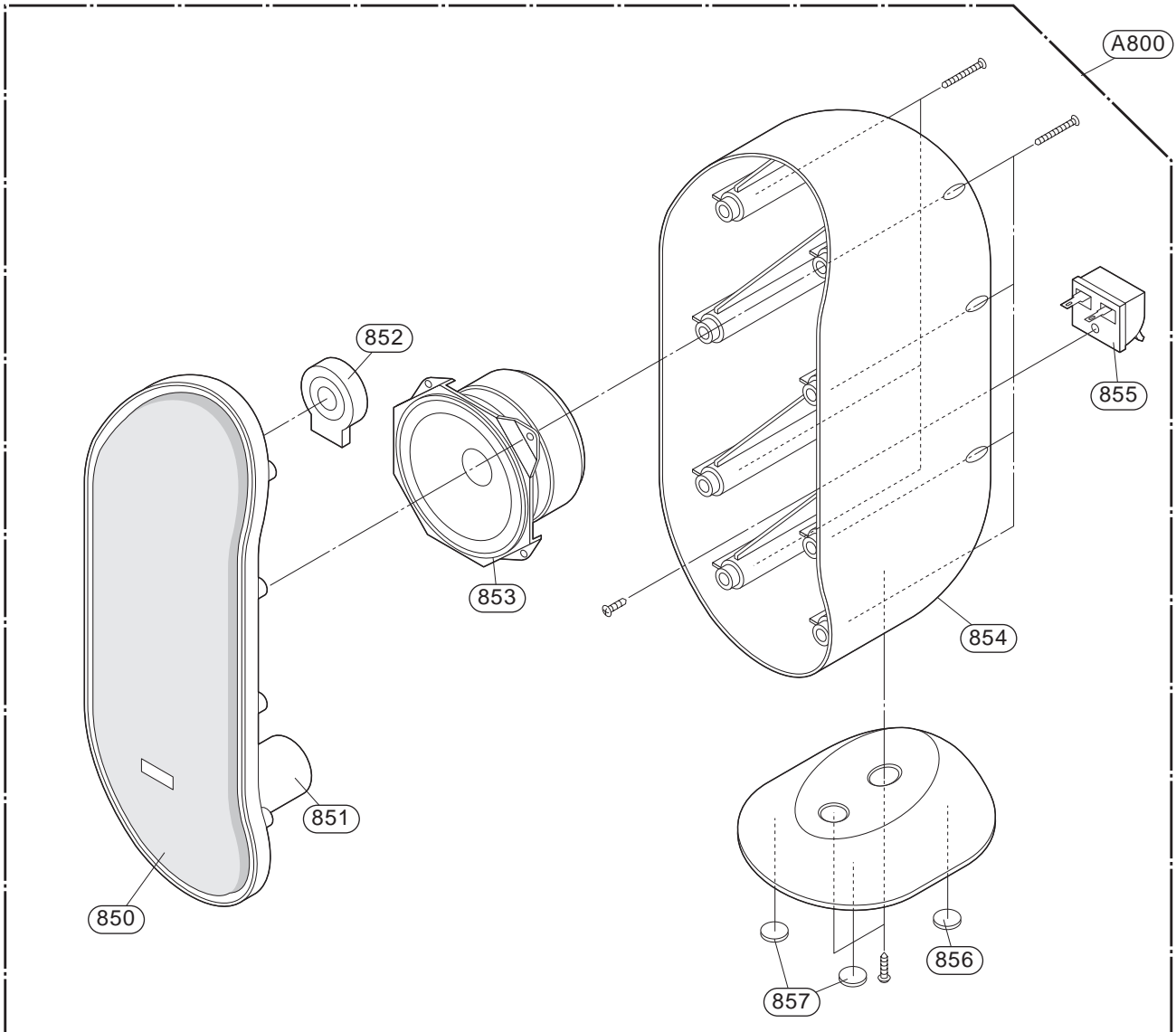

S	AL	LOCA. NO.	PART NO.	DESCRIPTION	SPECIFICATION	REMARKS
		A800	6401RM0158A	SPEAKER ASSEMBLY	MSF-90SB90L SAMMI LHS-C640T SV	
		850	3530RMP044A	GRILLE	LHS-E6740T PRESS BK 0.6T	
		851	3720RMM015A	PANEL,AUDIO	SPK LHS-E6740T/C MOLD FRONT	
		852	6400DSMX02A	SPEAKER,TWEETER	DT-11ND-1 SAMMI TWEETER(DOME)	
		853	6400WSMC05A	SPEAKER,WOOFER	MSF-90SB90L SAMMI WOOFER 6 OHM	
		854	3110RMP073A	CASE	LHS-E6740T MOLD REAR	
		855	6871RU0038A	PWB(PCB) ASSEMBLY,SUBSET(AUDIO	LHS-C640/T6745/E740 STANDARD 2	
		856	3040RMP037A	BASE	LHS-E6740T MOLD BOTTOM STAND	
		857	3610RM0044A	FOOT	SPK LHS-T6540T/C OTHER EVA PHI	

8. Center Speaker Section (LHS-CX640C)

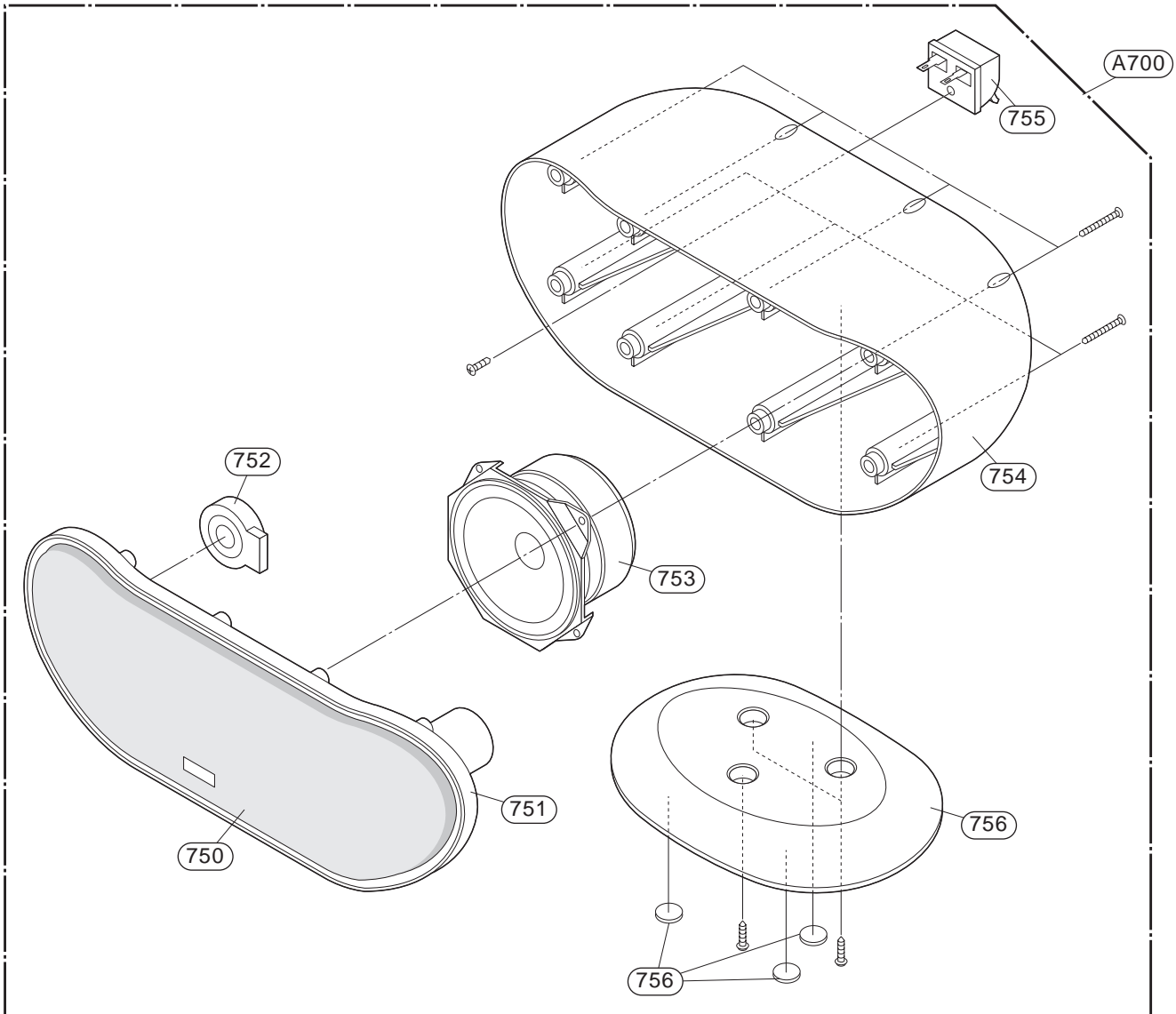

S	AL	LOCA. NO.	PART NO.	DESCRIPTION	SPECIFICATION	REMARKS
		A700	6401RM0159A	SPEAKER ASSEMBLY	MSF-90SB90L SAMMI LHS-C640C SV	
		750	3530RMP044B	GRILLE	LHS-E6740C PRESS BK 0.6T	
		751	3720RMM015A	PANEL,AUDIO	SPK LHS-E6740T/C MOLD FRONT	
		752	6400DSMX02A	SPEAKER,TWEETER	DT-11ND-1 SAMMI TWEETER(DOME)	
		753	6400WSMC05A	SPEAKER,WOOFER	MSF-90SB90L SAMMI WOOFER 6 OHM	
		754	3110RMP072A	CASE	LHS-E6740C MOLD REAR	
		755	6871RU0038A	PWB(PCB) ASSEMBLY,SUBSET(AUDIO	LHS-C640/T6745/E740 STANDARD 2	
		756	3040RMP036A	BASE	LHS-E6740C MOLD BOTTOM STAND	
		757	3610RM0044A	FOOT	SPK LHS-T6540T/C OTHER EVA PHI	

9. Packing Accessory Section

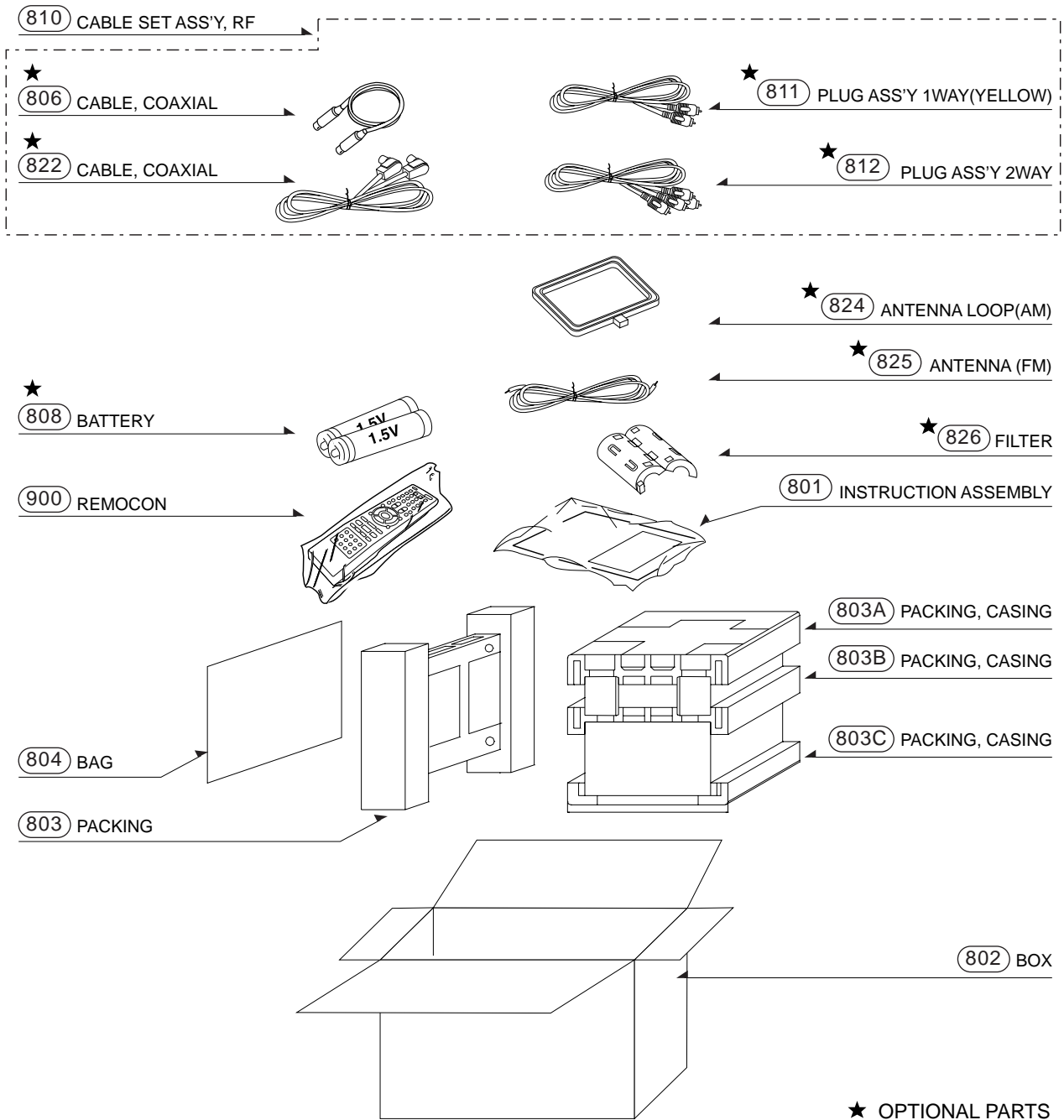

SECTION 3 ELECTRICAL CONTENTS

<p>OVERALL WIRING DIAGRAM3-2</p> <p>VCR PART</p> <p>ELECTRICAL ADJUSTMENT PROCEDURES3-3</p> <p>ELECTRICAL TROUBLESHOOTING GUIDE3-4</p> <p style="padding-left: 20px;">1. POWER(SMPS) CIRCUIT3-4</p> <p style="padding-left: 20px;">2. SYSTEM/KEY CIRCUIT3-6</p> <p style="padding-left: 20px;">3. SERVO CIRCUIT3-7</p> <p style="padding-left: 20px;">4. Y/C CIRCUIT3-10</p> <p style="padding-left: 20px;">5. Hi-Fi CIRCUIT3-14</p> <p style="padding-left: 20px;">6. TUNER/IF CIRCUIT3-17</p> <p>BLOCK DIAGRAMS3-19</p> <p style="padding-left: 20px;">1. POWER(SMPS) BLOCK DIAGRAM 13-19</p> <p style="padding-left: 20px;">2. POWER(SMPS) BLOCK DIAGRAM 23-21</p> <p style="padding-left: 20px;">3. TU/IF, NICAM & A2 BLOCK DIAGRAM3-23</p> <p style="padding-left: 20px;">4. VPS BLOCK DIAGRAM3-24</p> <p style="padding-left: 20px;">5. Y/C BLOCK DIAGRAM3-25</p> <p style="padding-left: 20px;">6. Hi-Fi BLOCK DIAGRAM3-27</p> <p style="padding-left: 20px;">7. SYSTEM BLOCK DIAGRAM3-29</p> <p>CIRCUIT DIAGRAMS3-31</p> <p style="padding-left: 20px;">1. POWER(SMPS) CIRCUIT DIAGRAM 1_200W3-31</p> <p style="padding-left: 20px;">2. POWER(SMPS) CIRCUIT DIAGRAM 1_400W3-33</p> <p style="padding-left: 20px;">3. POWER(SMPS) CIRCUIT DIAGRAM 23-35</p> <p style="padding-left: 20px;">4. TU/IF, NICAM & A2 CIRCUIT DIAGRAM3-37</p> <p style="padding-left: 20px;">5. A/V CIRCUIT DIAGRAM3-39</p> <p style="padding-left: 20px;">6. HI-FI CIRCUIT DIAGRAM3-41</p> <p style="padding-left: 20px;">7. SCART(JACK) CIRCUIT DIAGRAM3-43</p> <p style="padding-left: 20px;">8. SYSTEM CIRCUIT DIAGRAM3-45</p> <p style="padding-left: 20px;">9. TIMER CIRCUIT DIAGRAM_0TOOL3-47</p> <p style="padding-left: 20px;">10. TIMER CIRCUIT DIAGRAM_5TOOL / 7TOOL ..3-49</p> <p style="padding-left: 20px;">11. TIMER CIRCUIT DIAGRAM_6TOOL3-51</p> <p style="padding-left: 40px;">• WAVEFORM & VOLTAGE SHEET3-53</p> <p style="padding-left: 40px;">• CIRCUIT VOLTAGE CHART3-55</p> <p>PRINTED CIRCUIT DIAGRAMS3-59</p> <p style="padding-left: 20px;">1. MAIN P.C.BOARD3-59</p> <p style="padding-left: 20px;">2. KEY(LEFT) P.C.BOARD3-61</p> <p style="padding-left: 20px;">3. KEY(RIGHT) P.C.BOARD3-63</p> <p style="padding-left: 20px;">4. SMPS P.C.BOARD3-65</p> <p>DVD PART</p> <p>ELECTRICAL TROUBLESHOOTING GUIDE3-67</p> <p style="padding-left: 20px;">1. SYSTEM OPERATION FLOW3-67</p> <p style="padding-left: 20px;">2. SYSTEM TEST FLOW3-68</p> <p>DETAILS AND WAVEFORMS ON SYSTEM TEST AND DEBUGGING3-74</p> <p style="padding-left: 20px;">1. SYSTEM 27MHZ CLOCK, RESET, FLASH R/W SIGNAL3-74</p>	<p style="padding-left: 20px;">2. SDRAM CLOCK3-76</p> <p style="padding-left: 20px;">3. TRAY OPEN/CLOSE SIGNAL3-76</p> <p style="padding-left: 20px;">4. SLED CONTROL RELATED SIGNAL (NO DISC CONDITION)3-77</p> <p style="padding-left: 20px;">5. LENS CONTROL RELATED SIGNAL (NO DISC CONDITION)3-77</p> <p style="padding-left: 20px;">6. LASER POWER CONTROL RELATED SIGNAL(NO DISC CONDITION)3-78</p> <p style="padding-left: 20px;">7. DISC TYPE JUDGEMENT WAVEFORM3-78</p> <p style="padding-left: 20px;">8. FOCUS ON WAVEFORM3-80</p> <p style="padding-left: 20px;">9. SPINDLE CONTROL WAVEFORM (NO DISC CONDITION)3-81</p> <p style="padding-left: 20px;">10. TRACKING CONTROL RELATED SIGNAL(SYSTEM CHECKING)3-82</p> <p style="padding-left: 20px;">11. MT1389 AUDIO OPTICAL AND COAXIAL OUTPUT(SPDIF)3-83</p> <p style="padding-left: 20px;">12. MT1389 VIDEO OUTPUT WAVEFORM3-83</p> <p style="padding-left: 20px;">13. MT1389 AUDIO OUTPUT TO AUDIO DAC3-84</p> <p style="padding-left: 20px;">14. AUDIO OUTPUT FROM AUDIO DAC3-85</p> <p style="padding-left: 20px;">15. DVD & AMP WAVEFORMS3-86</p> <p>BLOCK DIAGRAMS3-87</p> <p style="padding-left: 20px;">1. OVERALL BLOCK DIAGRAM_200W3-87</p> <p style="padding-left: 20px;">2. OVERALL BLOCK DIAGRAM_400W3-88</p> <p style="padding-left: 20px;">3. SERVO BLOCK DIAGRAM3-89</p> <p style="padding-left: 20px;">4. MPEG & MEMORY BLOCK DIAGRAM3-90</p> <p style="padding-left: 20px;">5. VIDEO & AUDIO BLOCK DIAGRAM3-91</p> <p style="padding-left: 20px;">6. DVD & AMP BLOCK DIAGRAM3-92</p> <p>CIRCUIT DIAGRAMS3-93</p> <p style="padding-left: 20px;">1. MPEG CIRCUIT DIAGRAM3-93</p> <p style="padding-left: 20px;">2. RF & SERVO CIRCUIT DIAGRAM3-95</p> <p style="padding-left: 20px;">3. AUDIO, μ_COM CIRCUIT DIAGRAM(DVD & AMP)3-97</p> <p style="padding-left: 20px;">4. DIGITAL AMP CIRCUIT DIAGRAM (DVD & AMP)_200W3-99</p> <p style="padding-left: 20px;">5. DIGITAL AMP CIRCUIT DIAGRAM (DVD & AMP)_400W3-101</p> <p style="padding-left: 20px;">6. PWM & CODEIC CIRCUIT DIAGRAM (DVD & AMP)_200W3-103</p> <p style="padding-left: 20px;">7. PWM & CODEIC CIRCUIT DIAGRAM (DVD & AMP)_400W3-105</p> <p style="padding-left: 20px;">8. INTERFACE CIRCUIT DIAGRAM (DVD & AMP)_200W3-107</p> <p style="padding-left: 20px;">9. INTERFACE CIRCUIT DIAGRAM (DVD & AMP)_400W3-109</p> <p style="padding-left: 40px;">• CIRCUIT VOLTAGE CHART_200W3-111</p> <p style="padding-left: 40px;">• CIRCUIT VOLTAGE CHART_200W3-115</p> <p>PRINTED CIRCUIT DIAGRAMS3-119</p> <p style="padding-left: 20px;">1. DVD & AMP P.C.BOARD_200W3-119</p> <p style="padding-left: 20px;">2. DVD & AMP P.C.BOARD_400W3-121</p>
---	---

OVERALL WIRING DIAGRAM

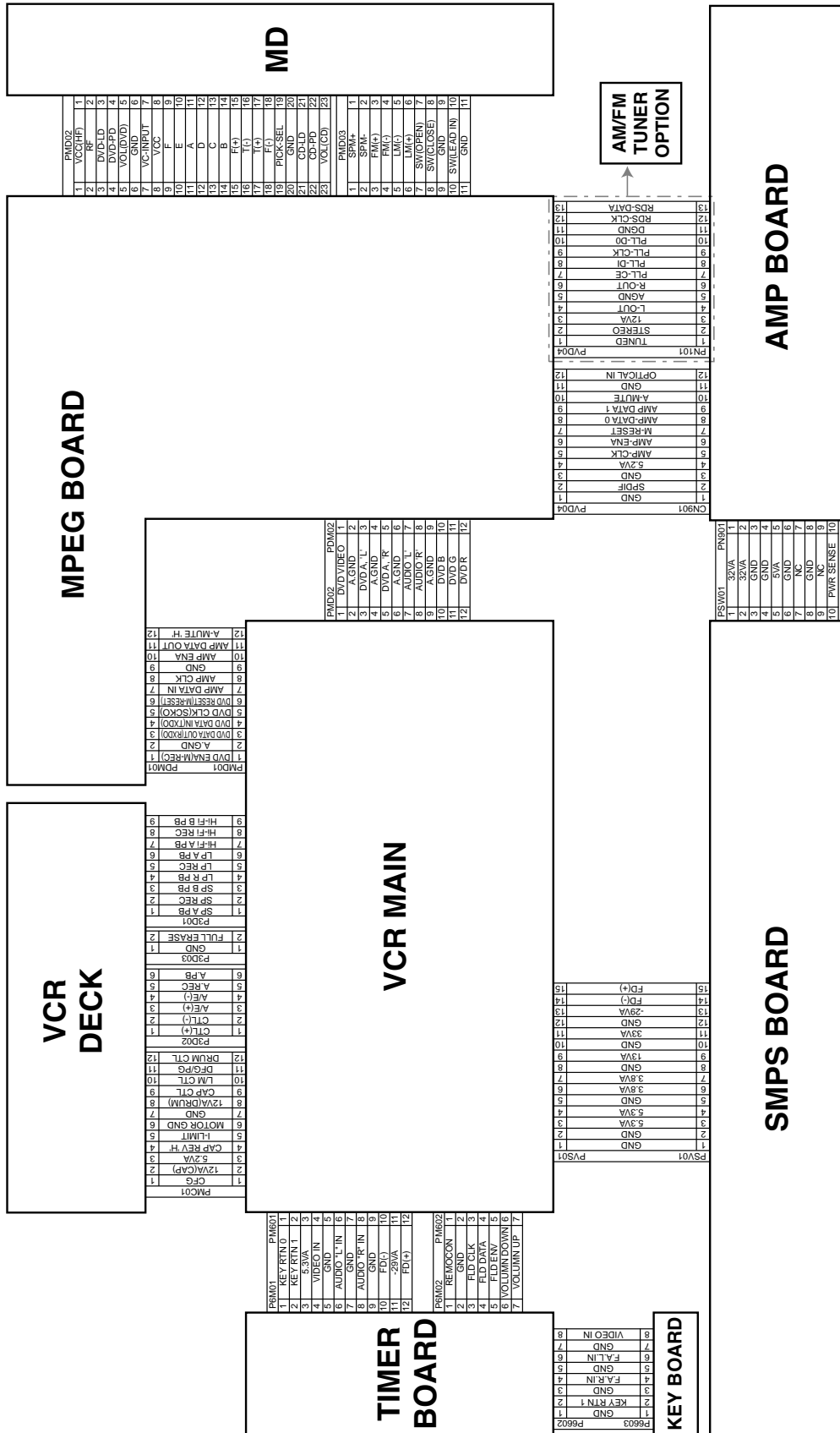

VCR PART

ELECTRICAL ADJUSTMENT PROCEDURES

1. Servo Adjustment

- 1) PG Adjustment
 - Test Equipment

a) OSCILLOSCOPE	b) PAL MODEL : PAL SP TEST TAPE
-----------------	---------------------------------

• Adjustment And Specification

MODE	MEASUREMENT POINT	ADJUSTMENT POINT	SPECIFICATION
PLAY	V.Out H/SW(W373, W374)		$6.5 \pm 0.5H$

• **Adjustment Procedure**

- a) Insert the SP Test Tape and play.
 - Note - Adjust the distance of X, pressing the Tracking(+) or Tracking(-) when the “ATR” is blink after the SP Test Tape is inserted.
- b) Connect the CH1 of the oscilloscope to the H/SW(W373, W374) and CH2 to the Video Out for the VCR.
- c) Trigger the mixed Combo Video Signal of CH2 to the CH1 H/SW(W373, W374), and then check the distance (time difference), which is from the selected A(B) Head point of the H/SW(W373, W374) signal to the starting point of the vertical synchronized signal, to $6.5H \pm 0.5H$ ($416\mu s$, $1H=64\mu s$).

• **PG Adjustment Method**

- a-1) Playback the SP standard tape
- b-2) Press the “OK” key on the Remote controller and the “REC” key on the Front Panel the same time, then it goes in to Tracking initial mode.
- c-3) Repeat the above step(No.b-2), then it finishes the PG adjusting automatically.
- d-4) Stop the playback, then it goes out to PG adjusting mode after many the PG data.

• **CONNECTION**

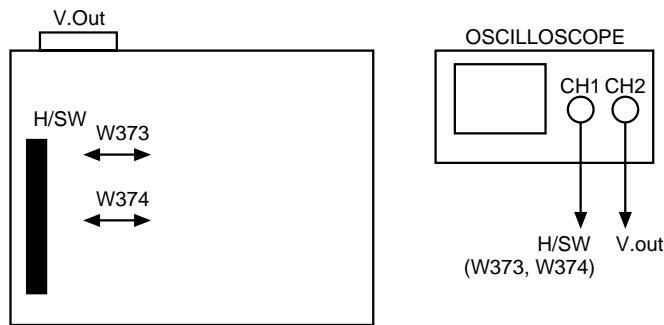

• **WAVEFORM**

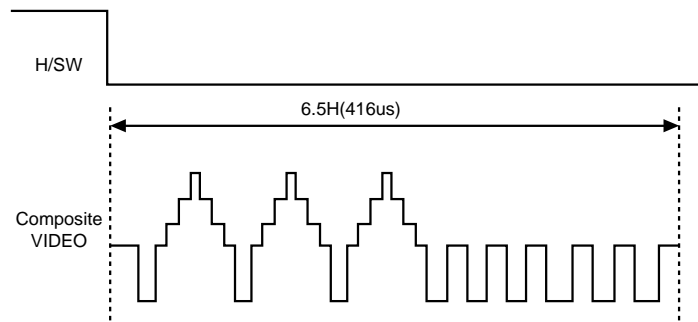

ELECTRICAL TROUBLESHOOTING GUIDE

1. Power(SMPS) CIRCUIT

(1) No 5.3VA (SYS/Hi-Fi/TUNER)

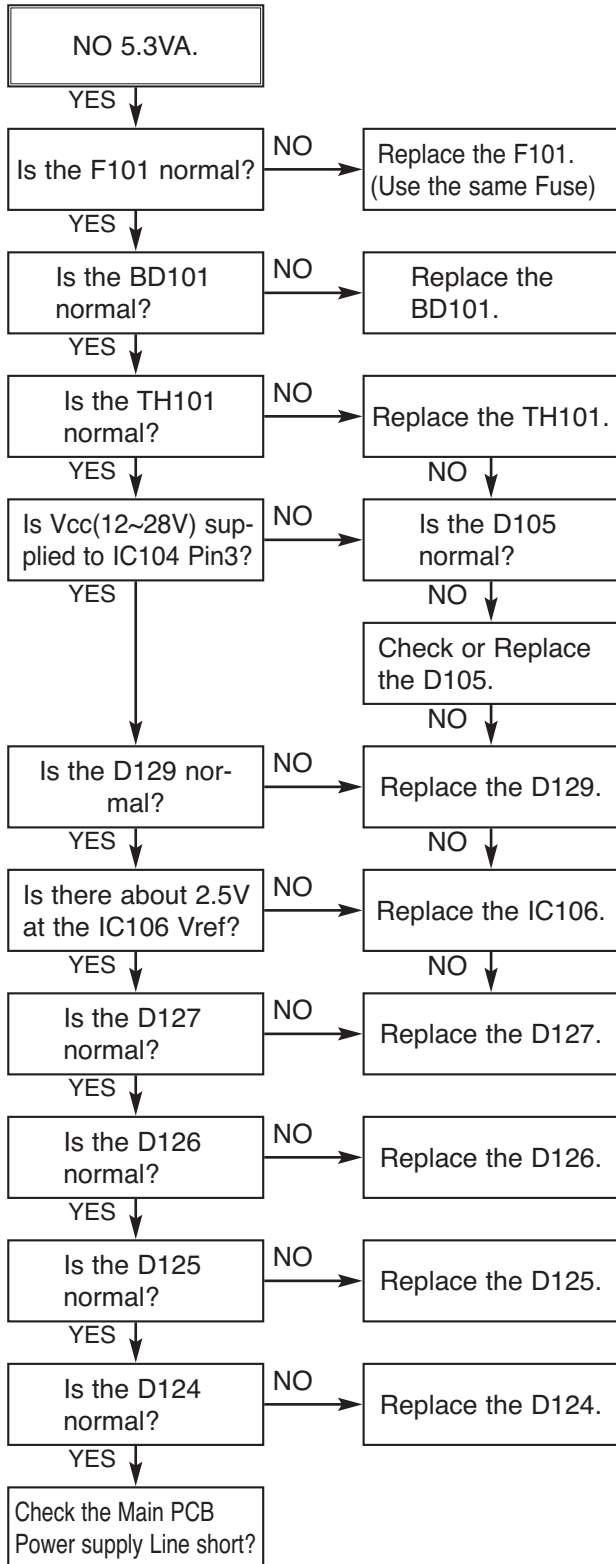

(2) No 5.0VA

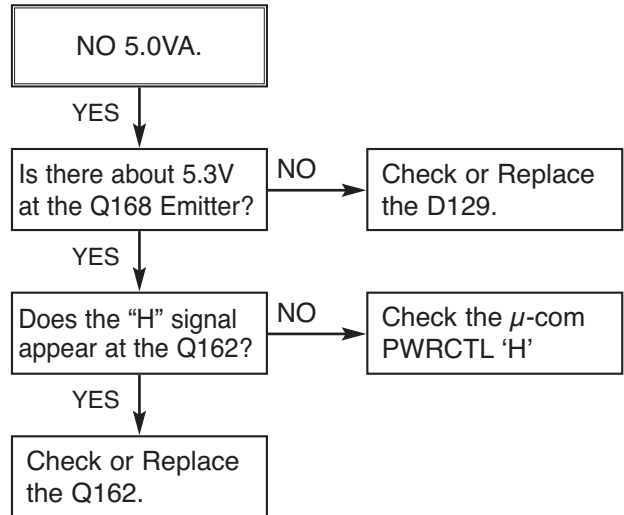

(3) No 3.3VA

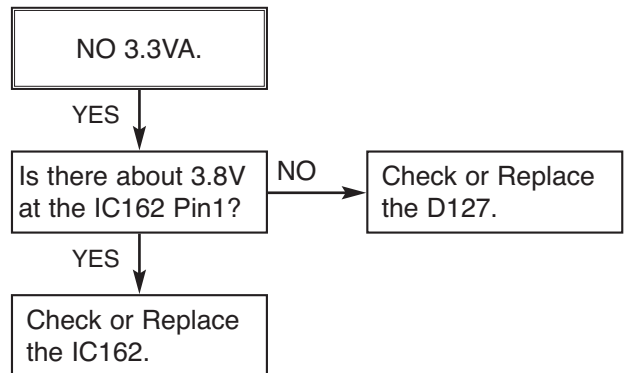

(4) No 12VA

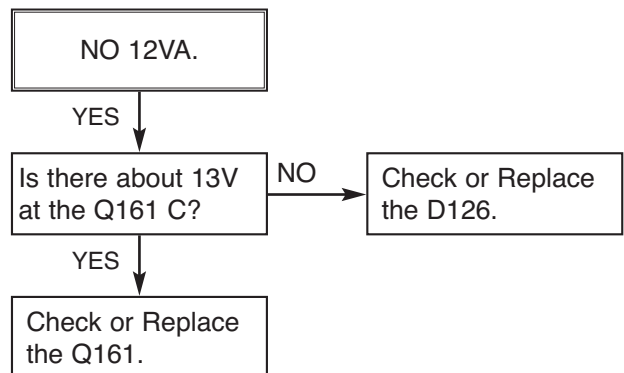

(5) No 32VA

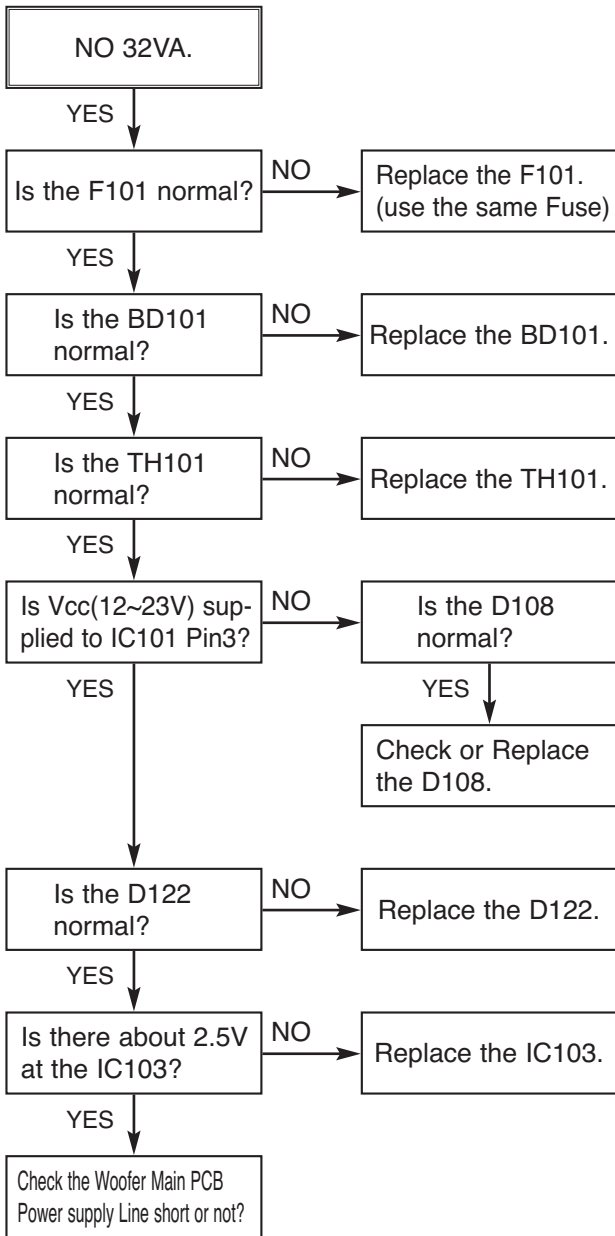

2. SYSTEM/KEY CIRCUIT

(1) AUTO STOP

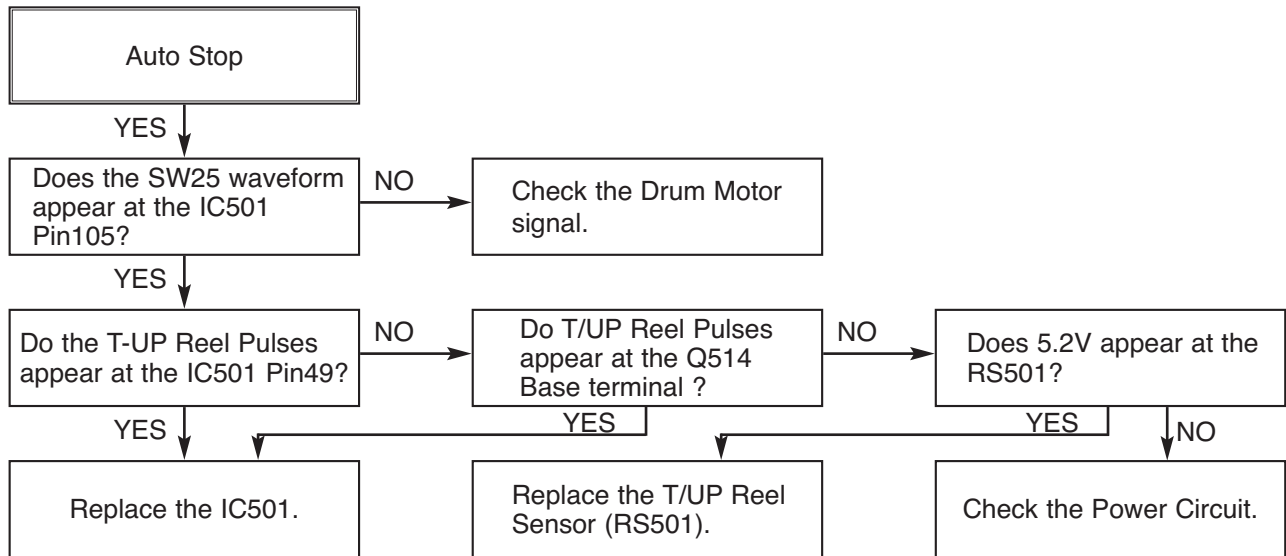

(2) The unstable loading of a Cassette tape

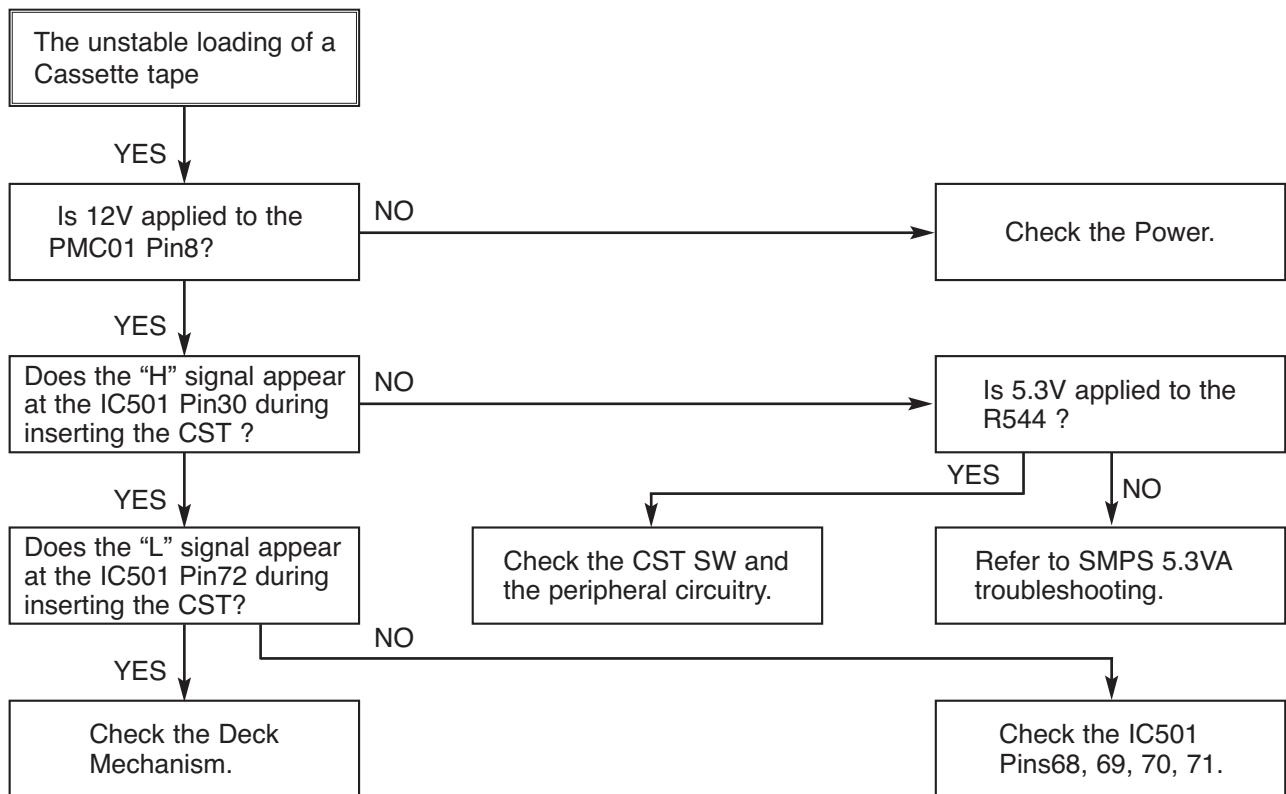

Caution : Auto stop can occur because Grease or Oil is dried up

3. SERVO CIRCUIT

(1) Unstable Video in PB MODE

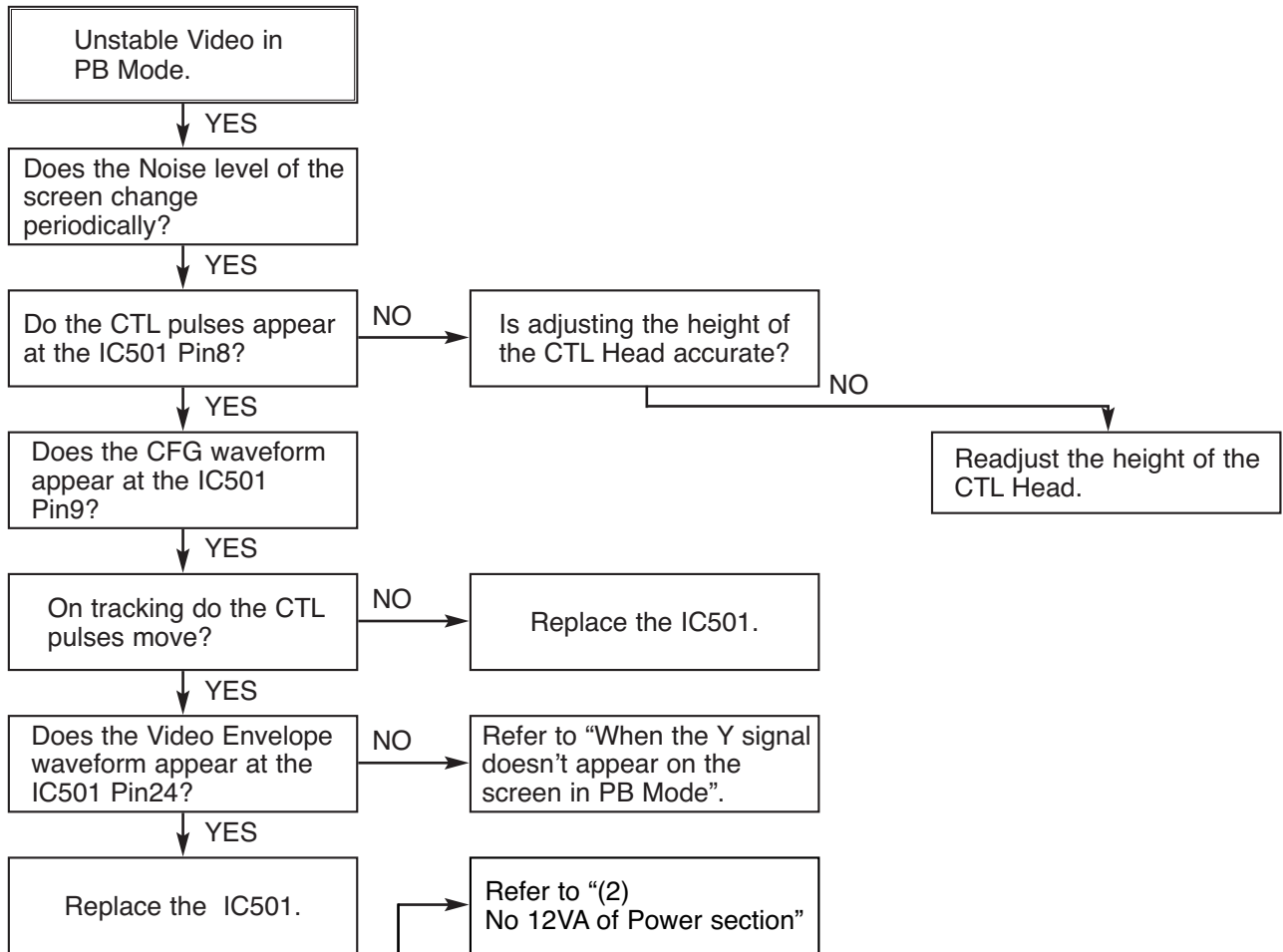

(2) When the Drum Motor doesn't run.

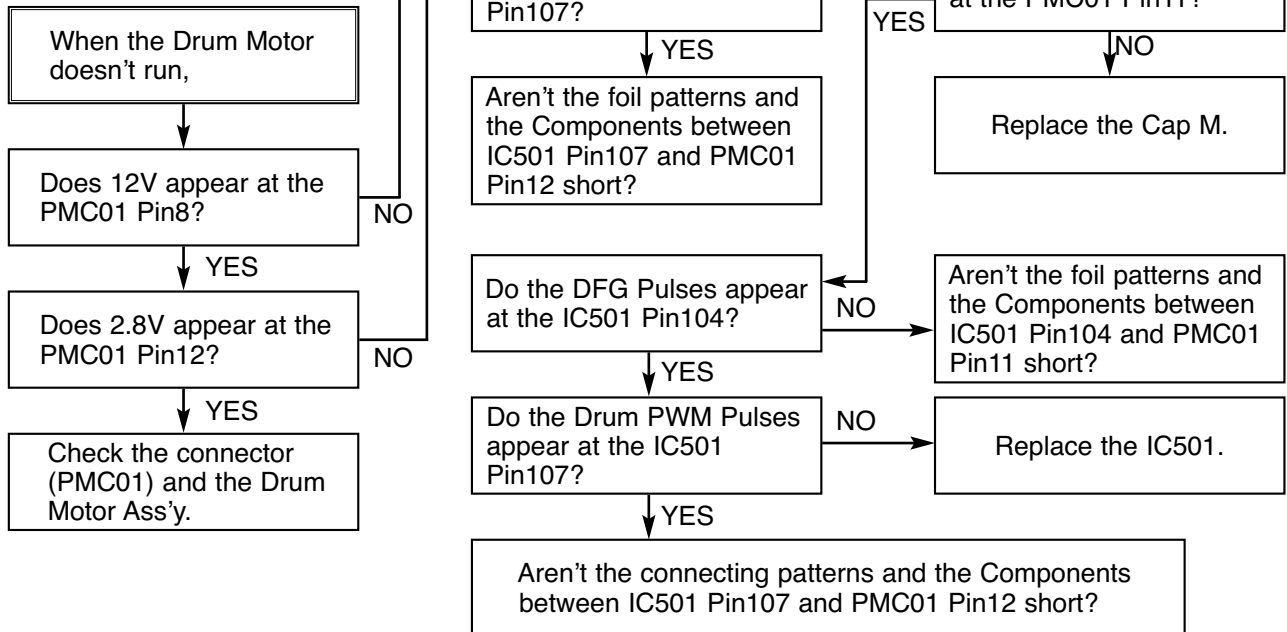

(3) When the Capstan Motor doesn't run,

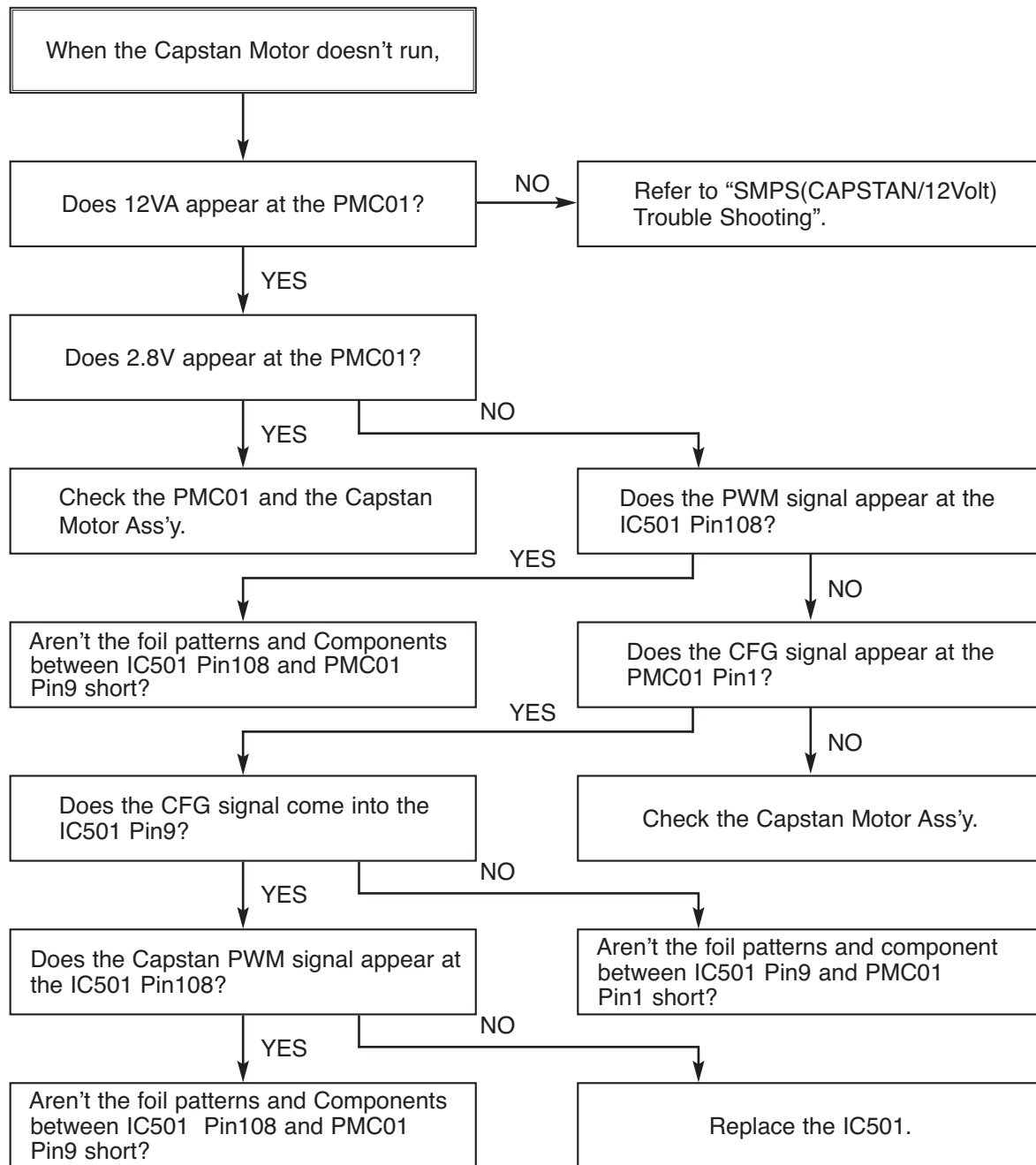

(4) KEY doesn't working

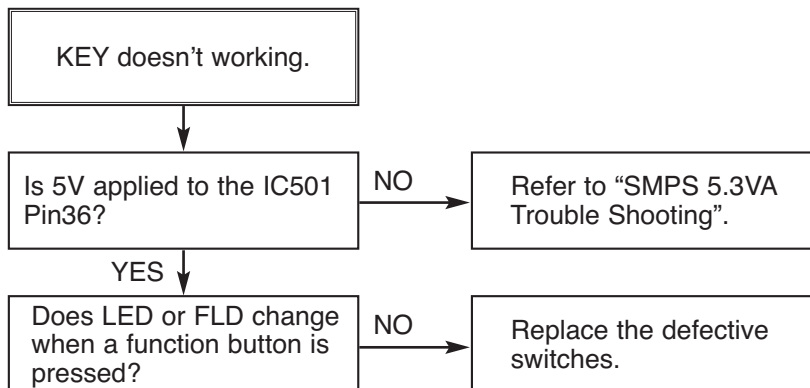

4. Y/C CIRCUIT

(1) No Video in EE Mode,

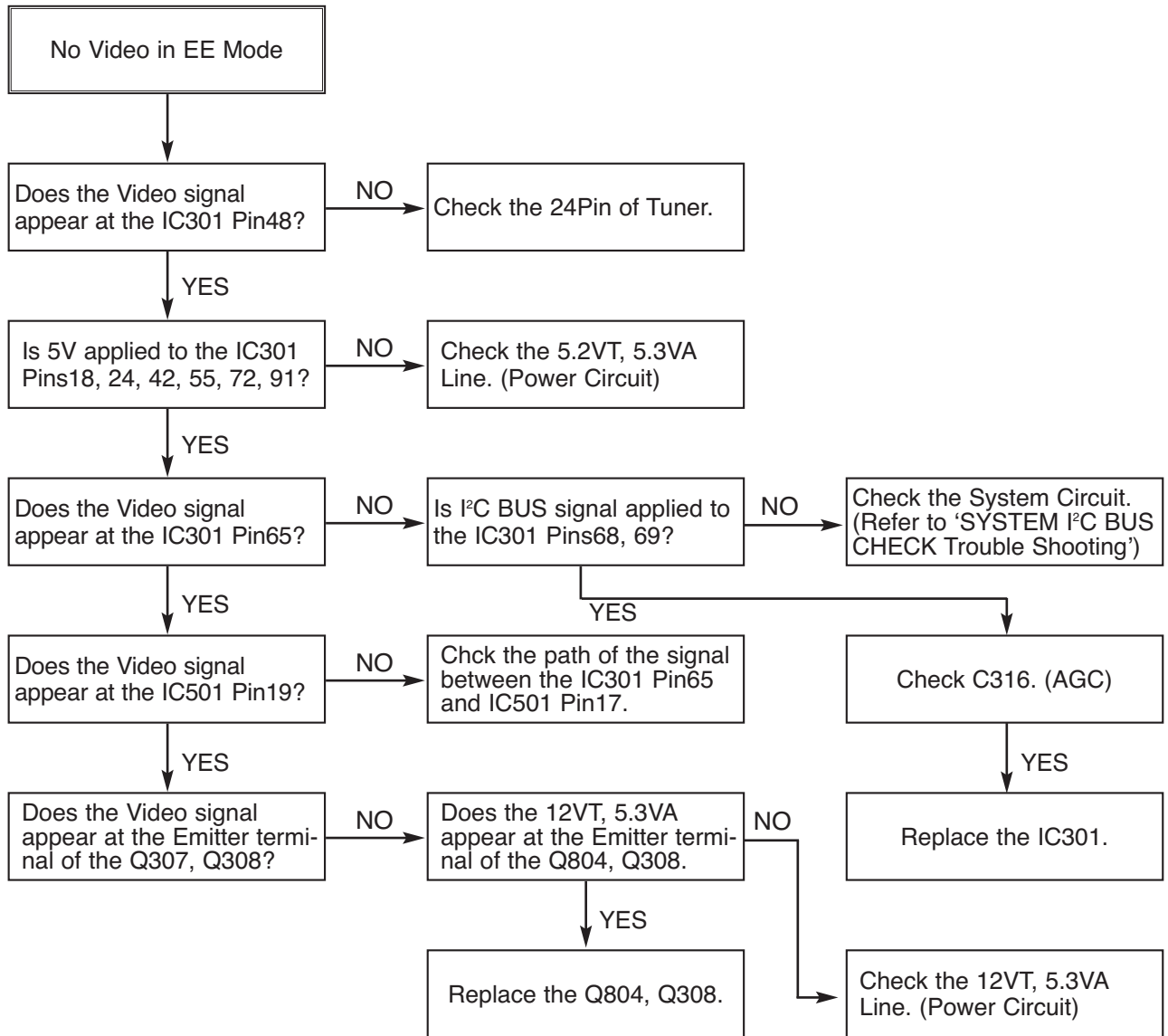

(2) When the Y(Luminance) signal doesn't appear on the screen in PB Mode,

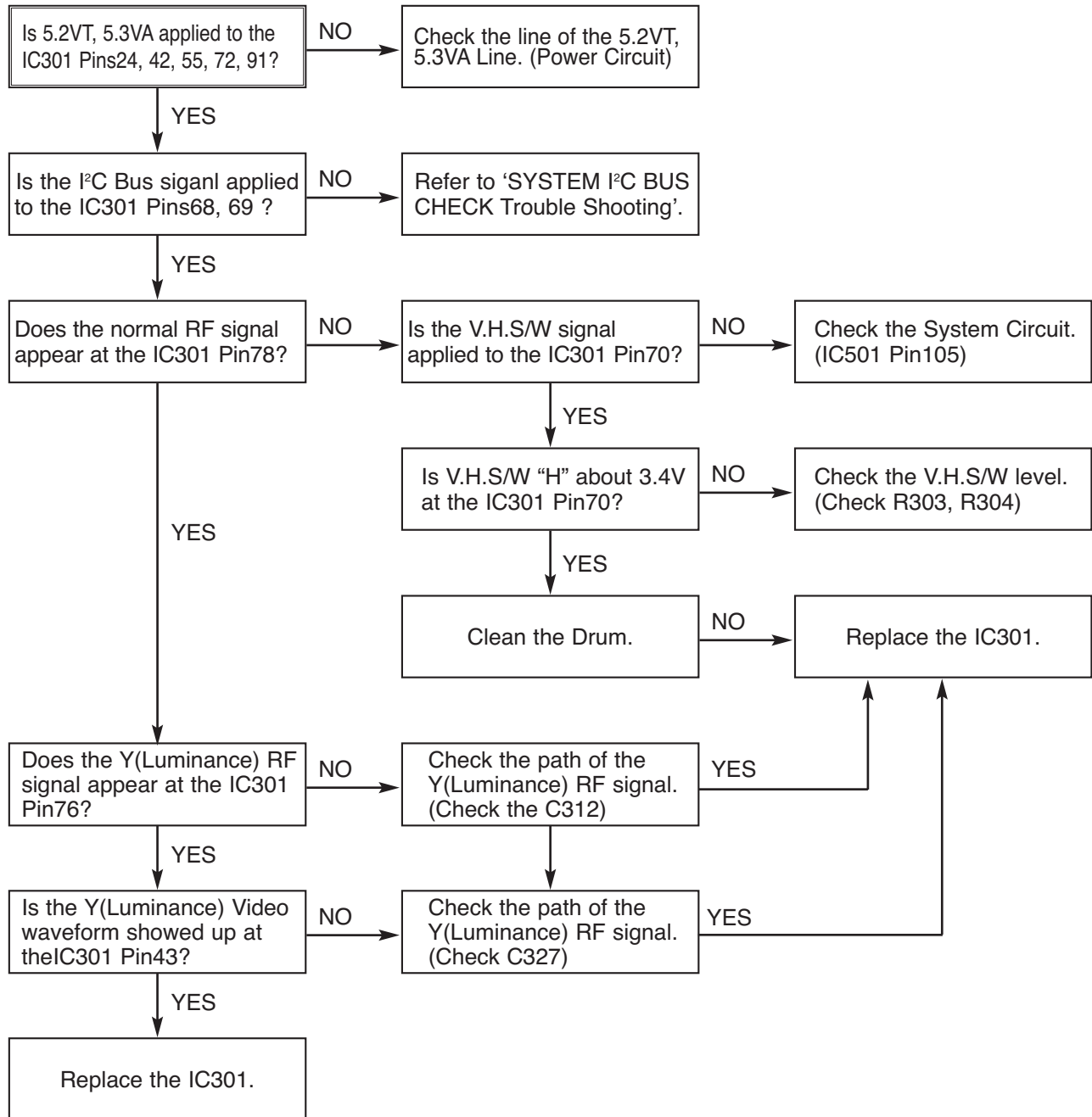

(3) When the C(Color) signal doesn't appear on the screen in PB Mode,

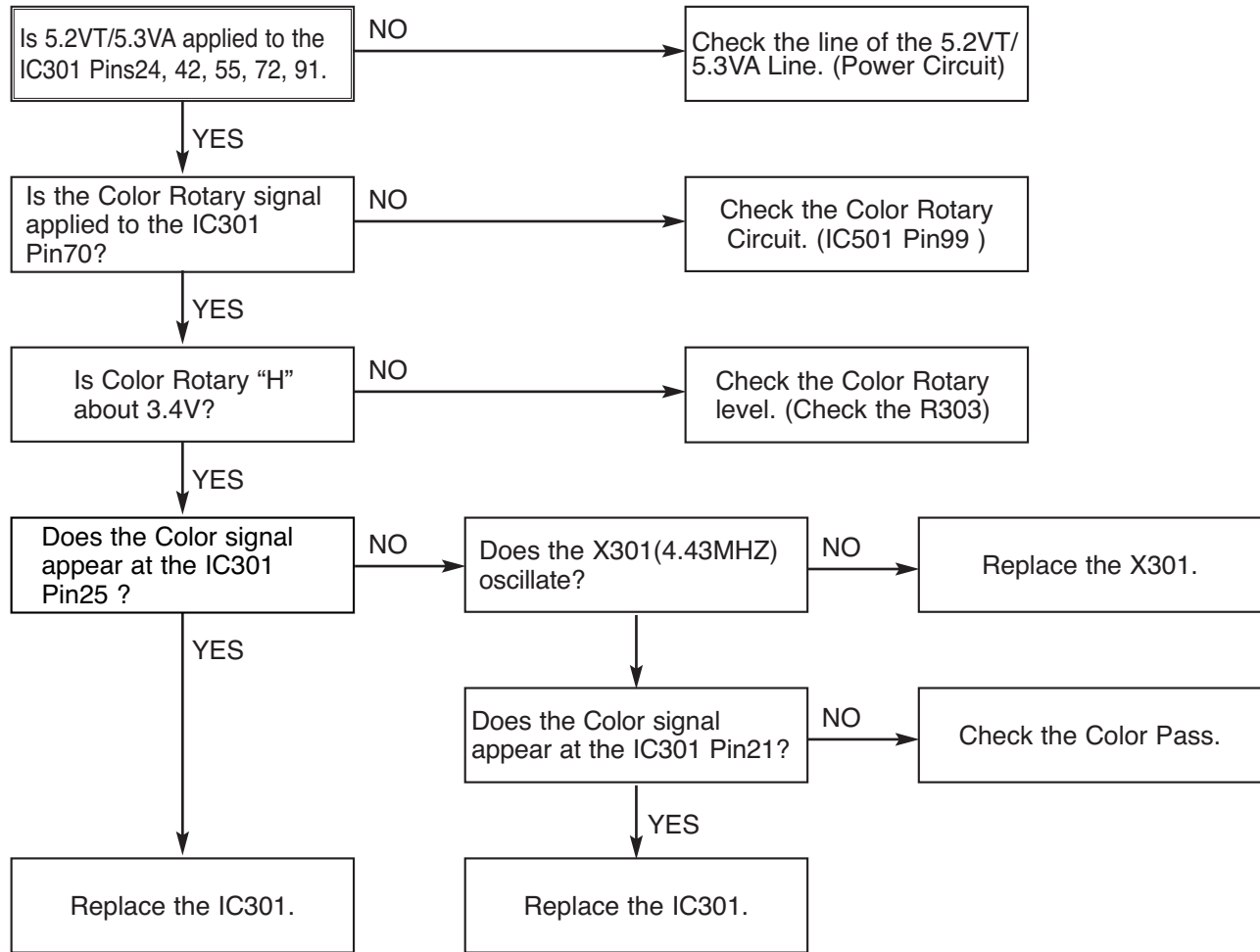

(4) When the Video signal doesn't appear on the screen in REC Mode,

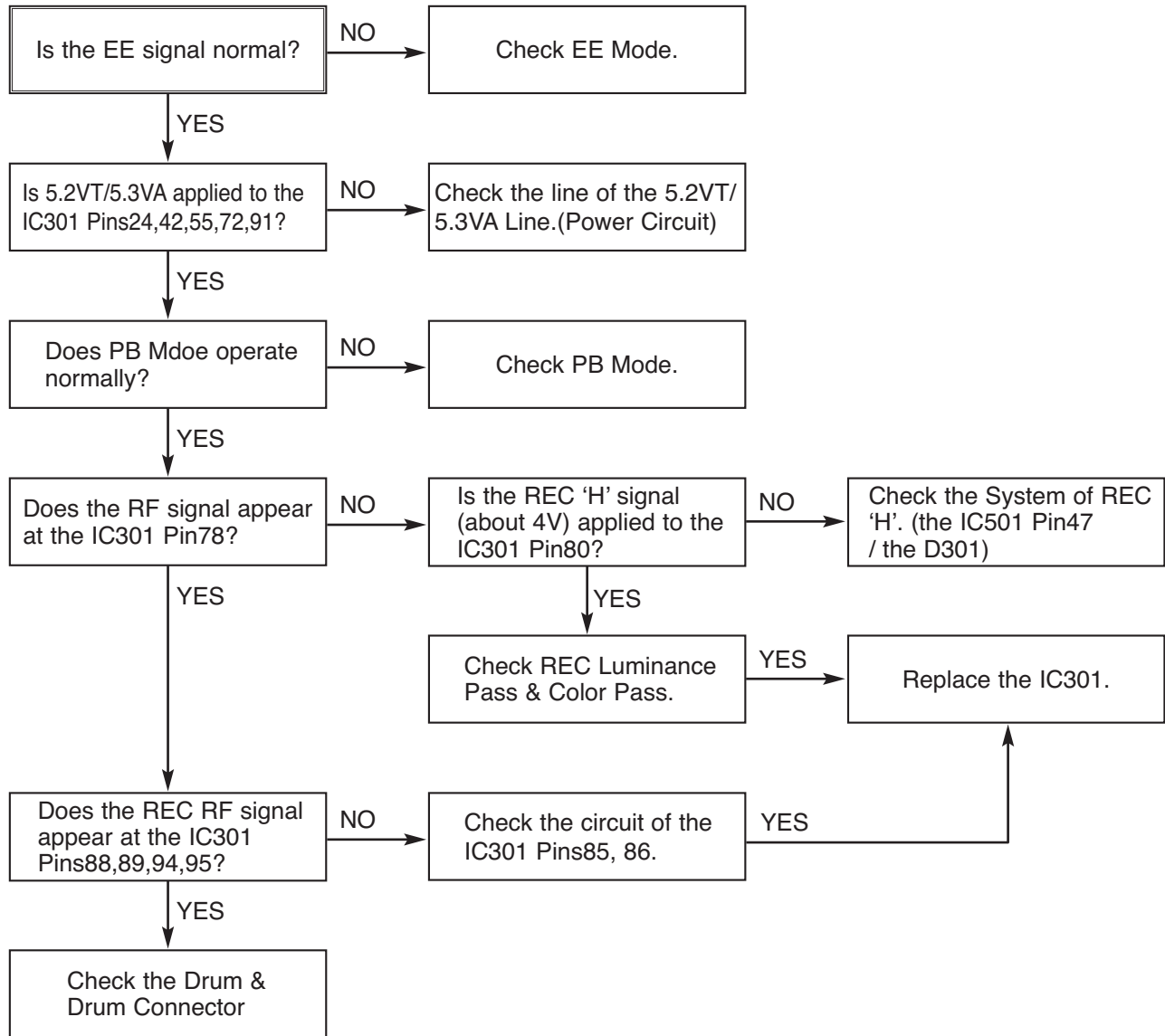

5. Hi-Fi CIRCUIT

(A) No Sound(EE Mode)

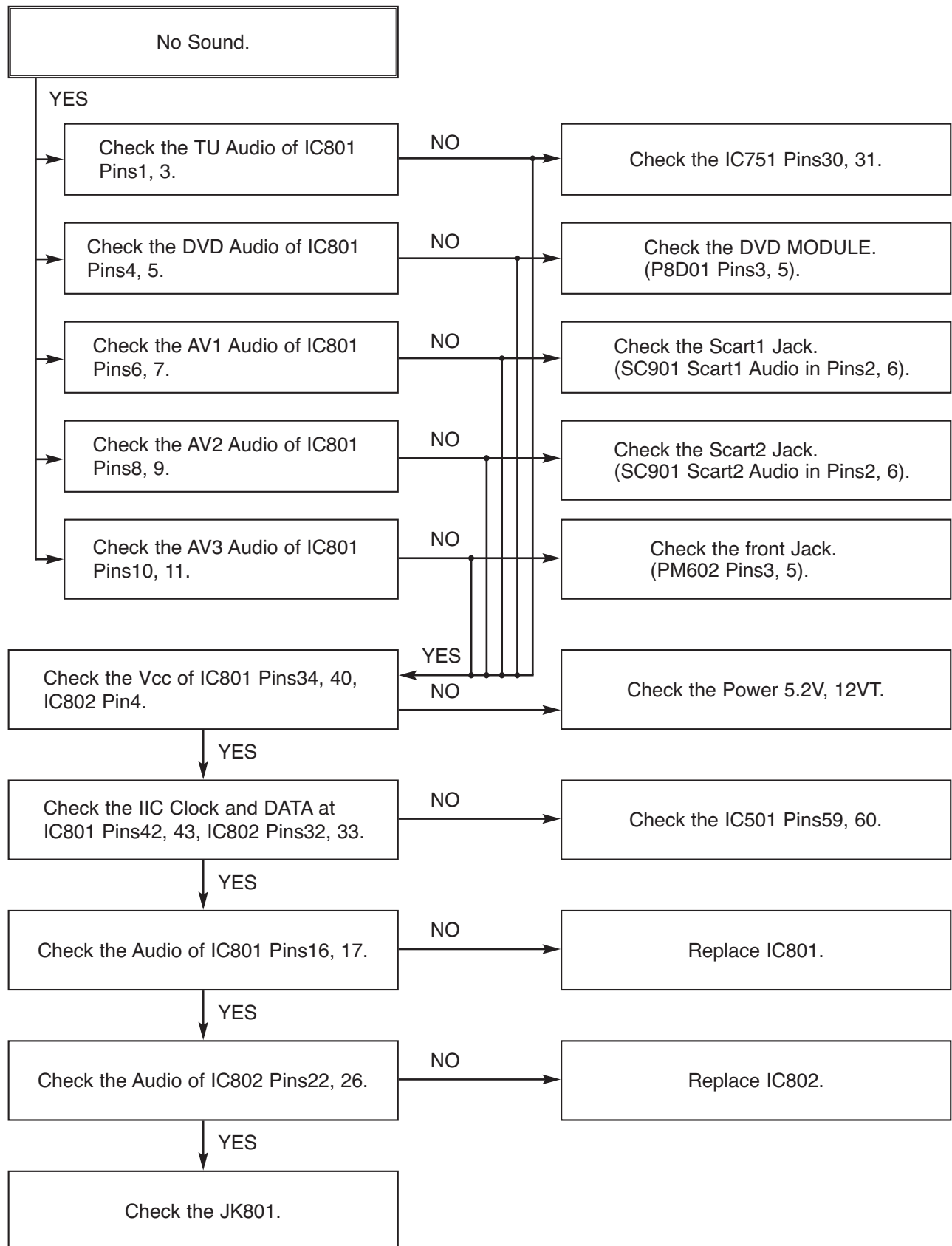

(B) Hi-Fi Playback

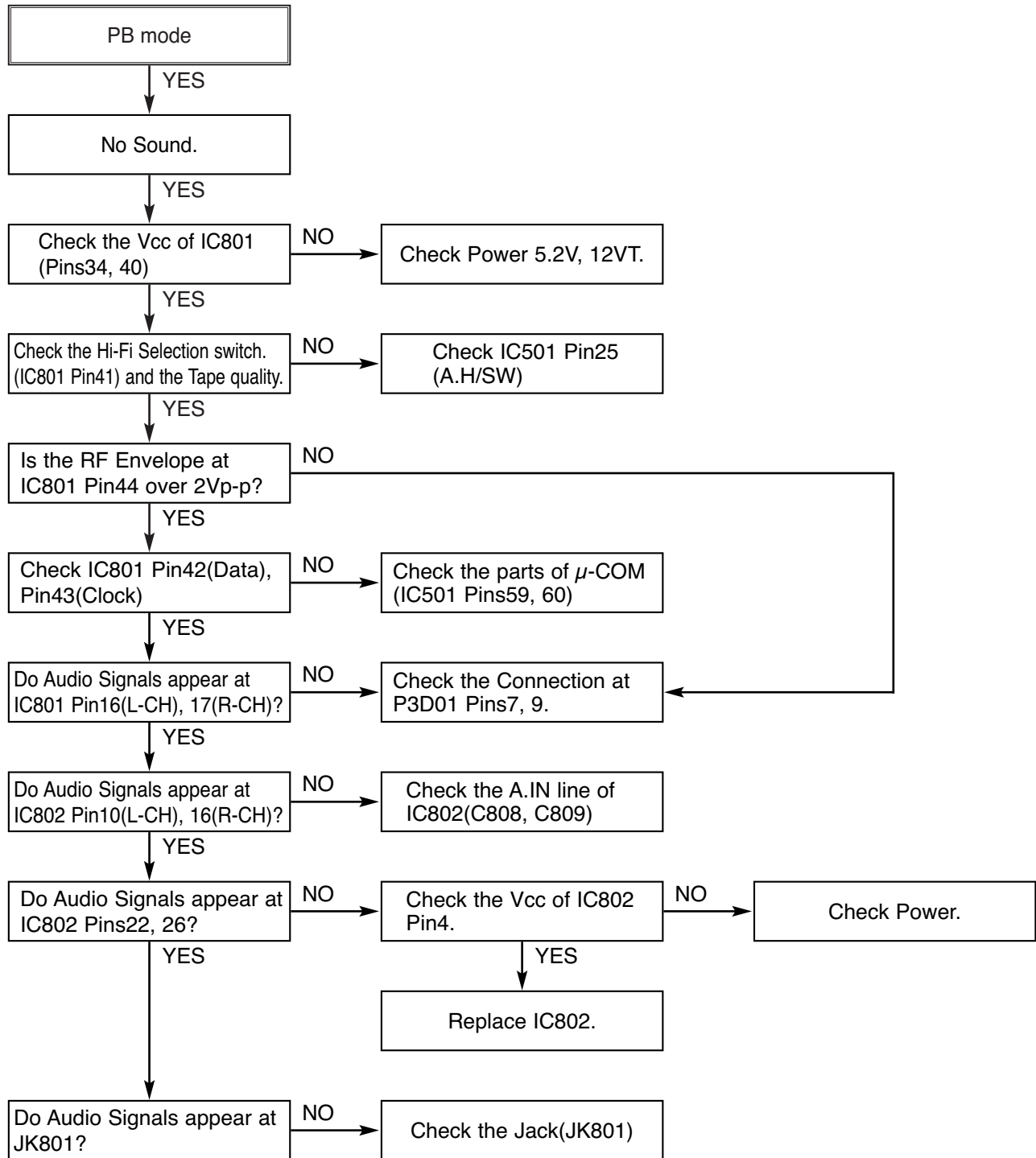

(C)

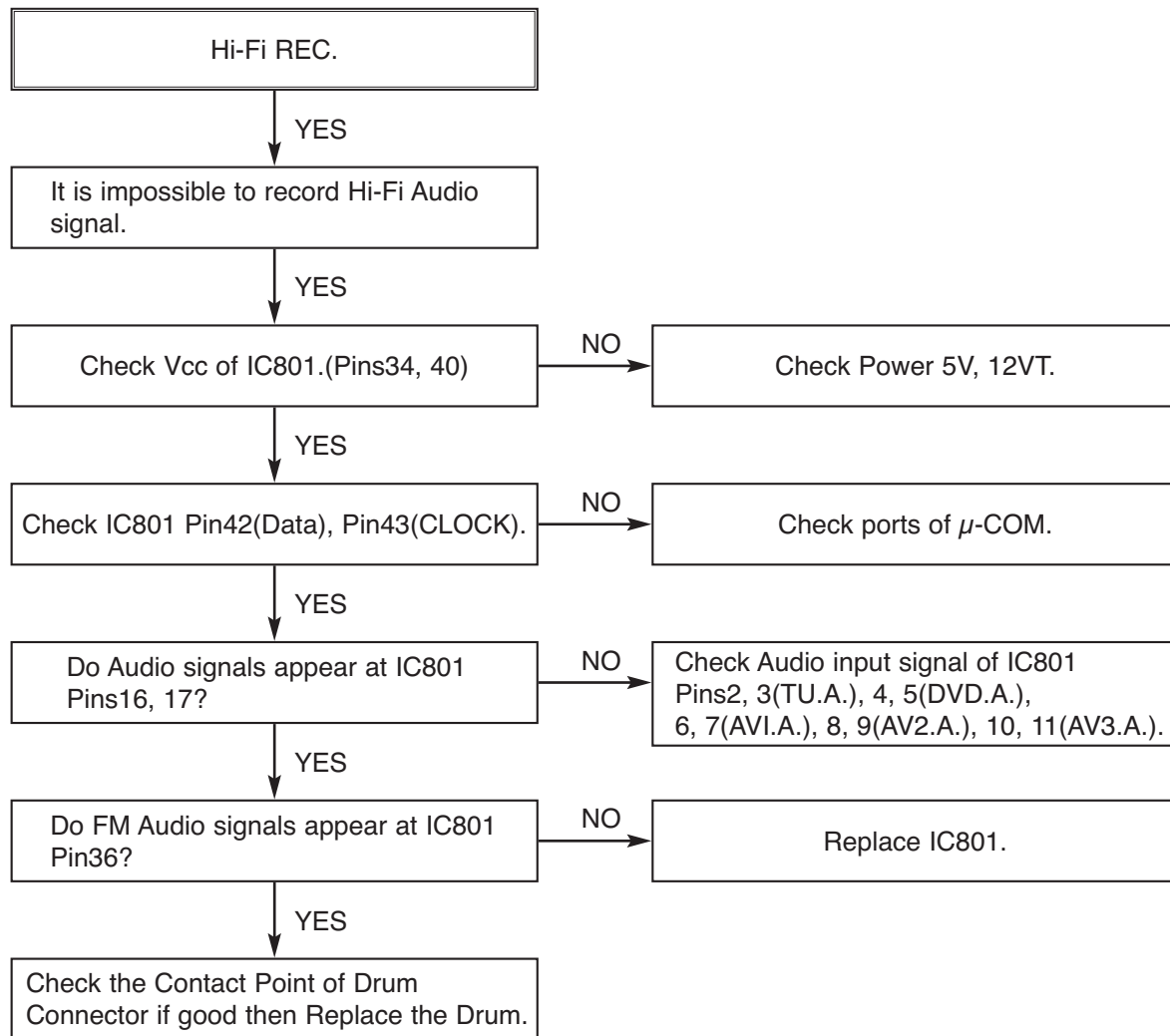

6. Tuner/IF CIRCUIT

(A) No Picture on the TV screen

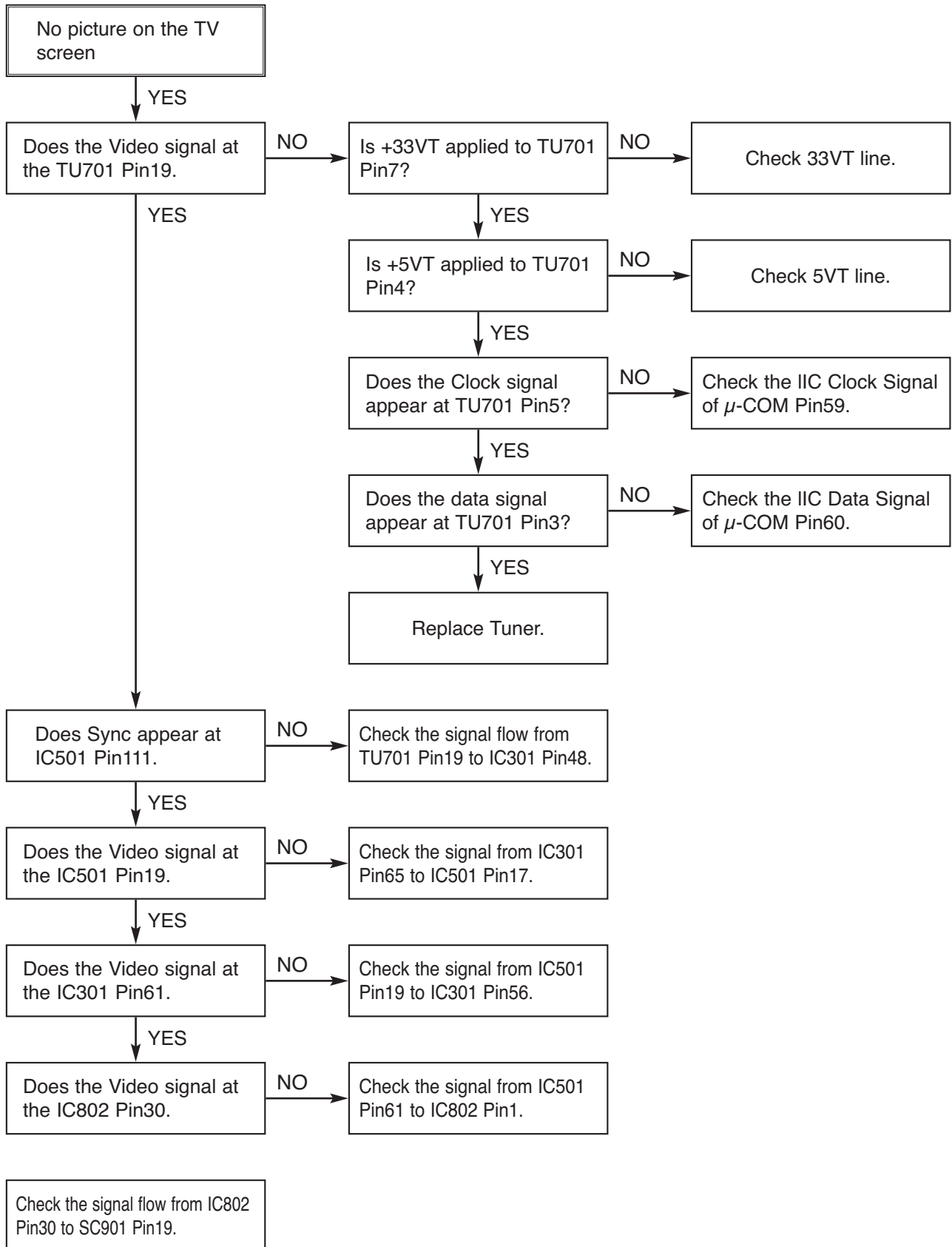

(B) No Sound

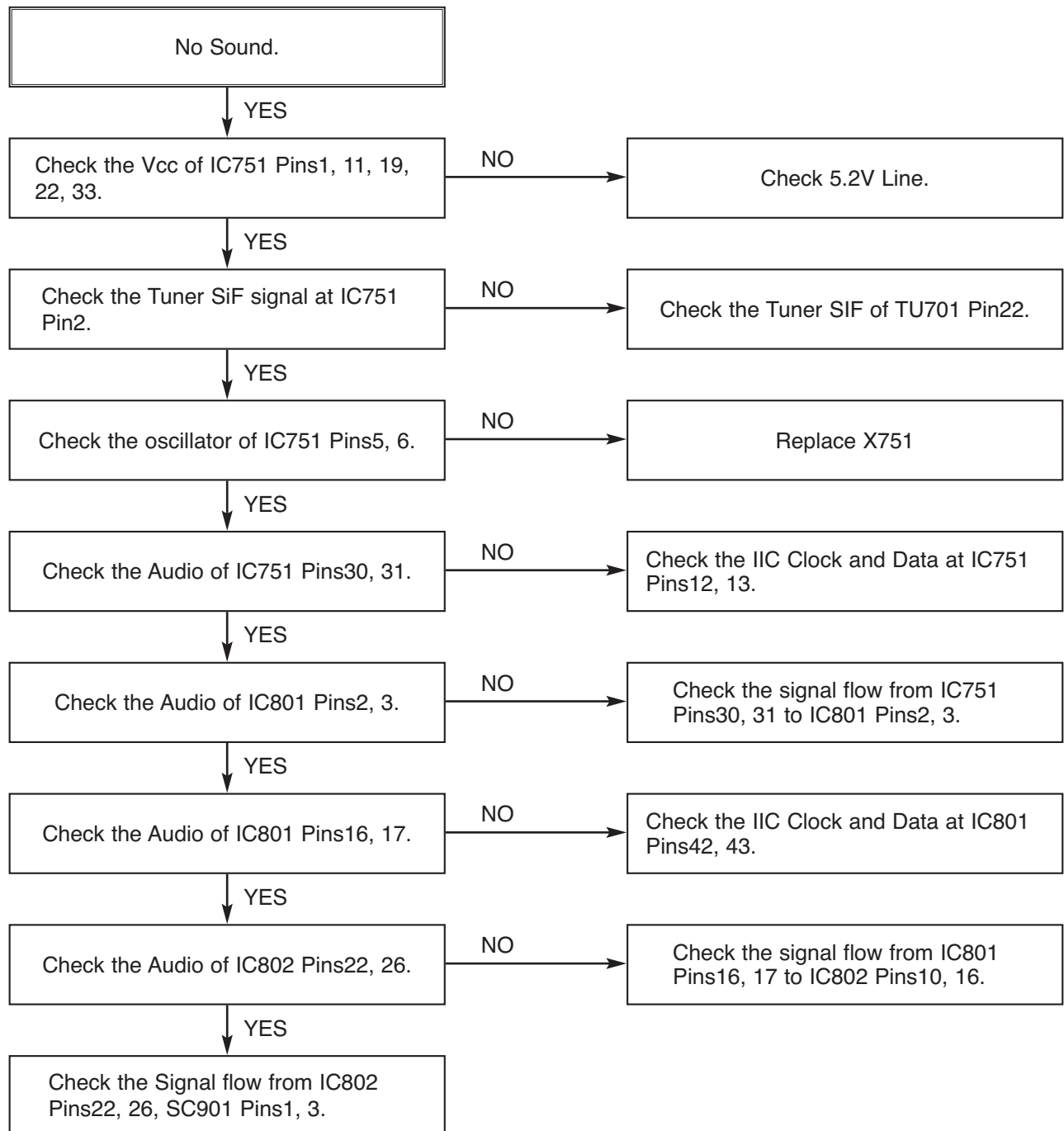

BLOCK DIAGRAMS

1. POWER(SMPS) BLOCK DIAGRAM 1

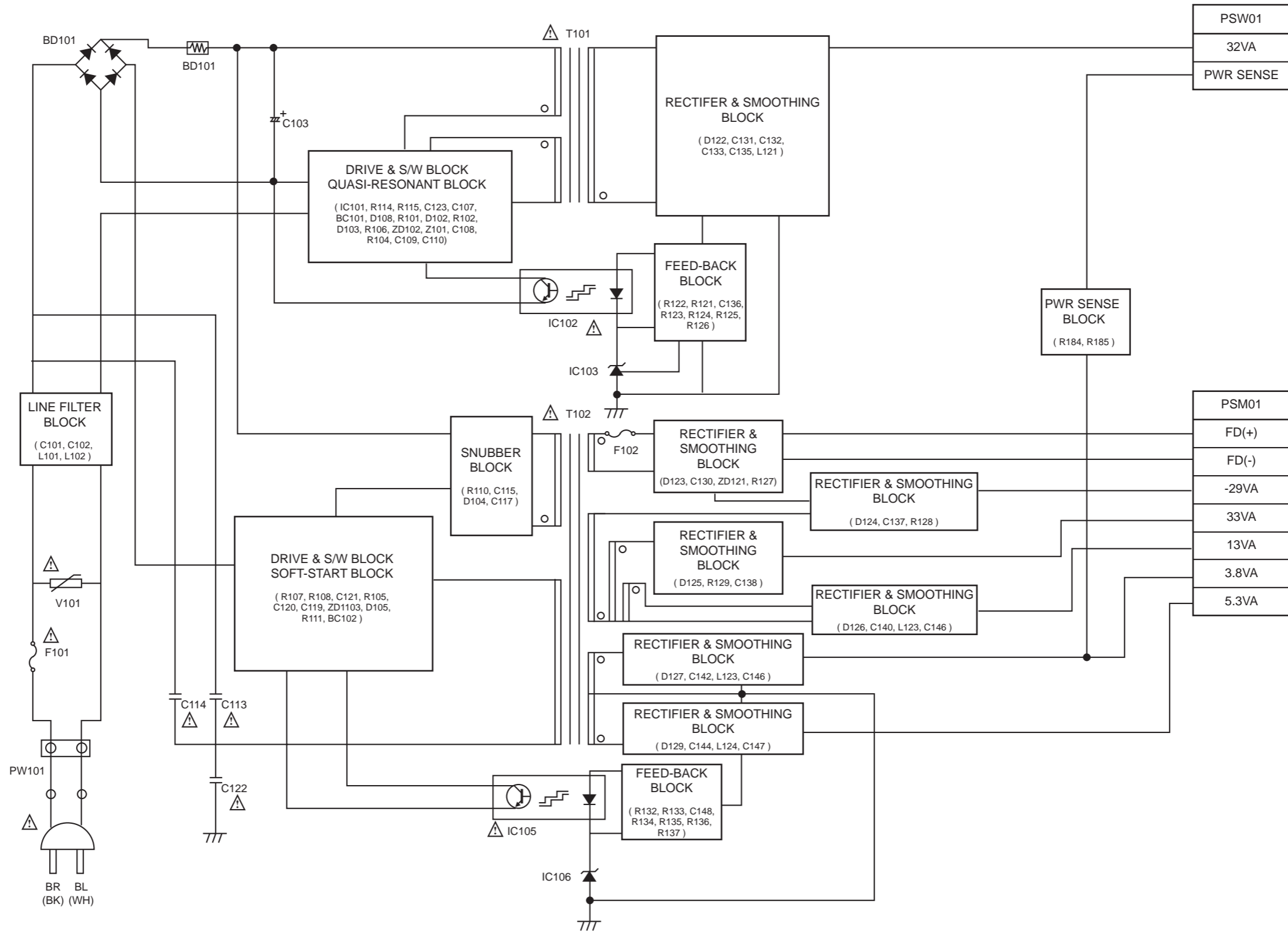

2. POWER(SMPS) BLOCK DIAGRAM 2

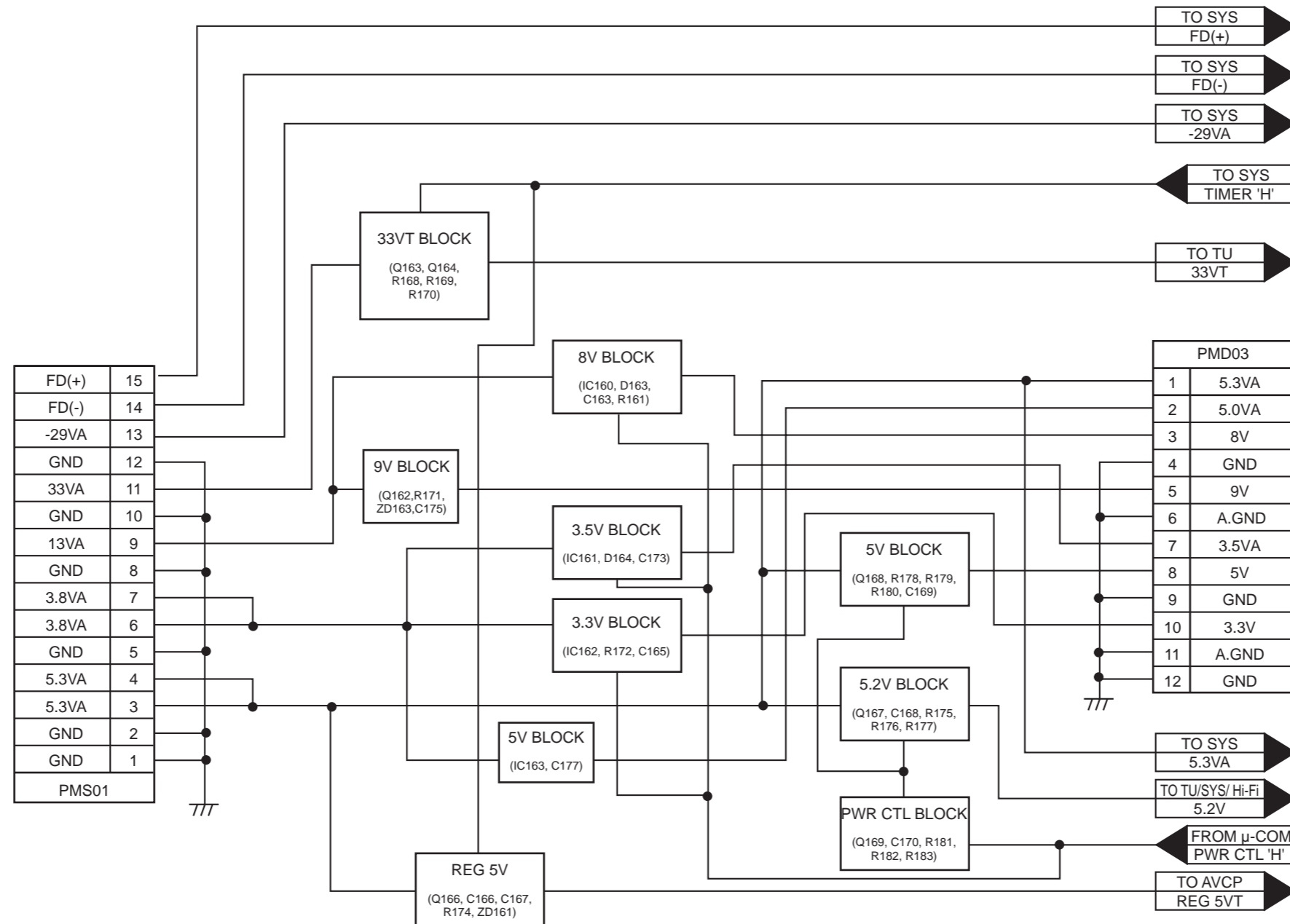

3. Tu/IF, NICAM & A2 BLOCK DIAGRAM

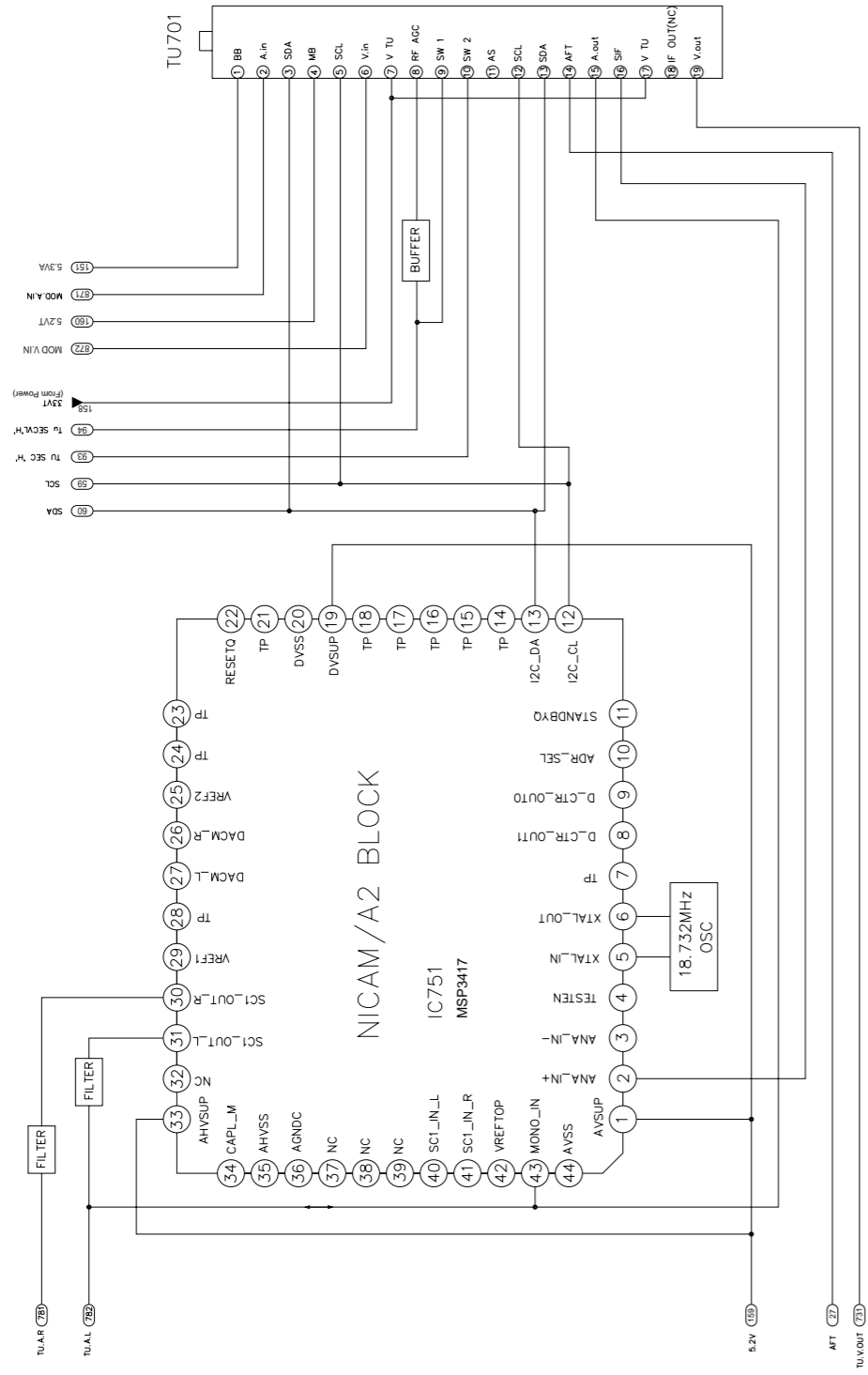

4. VPS BLOCK DIAGRAM

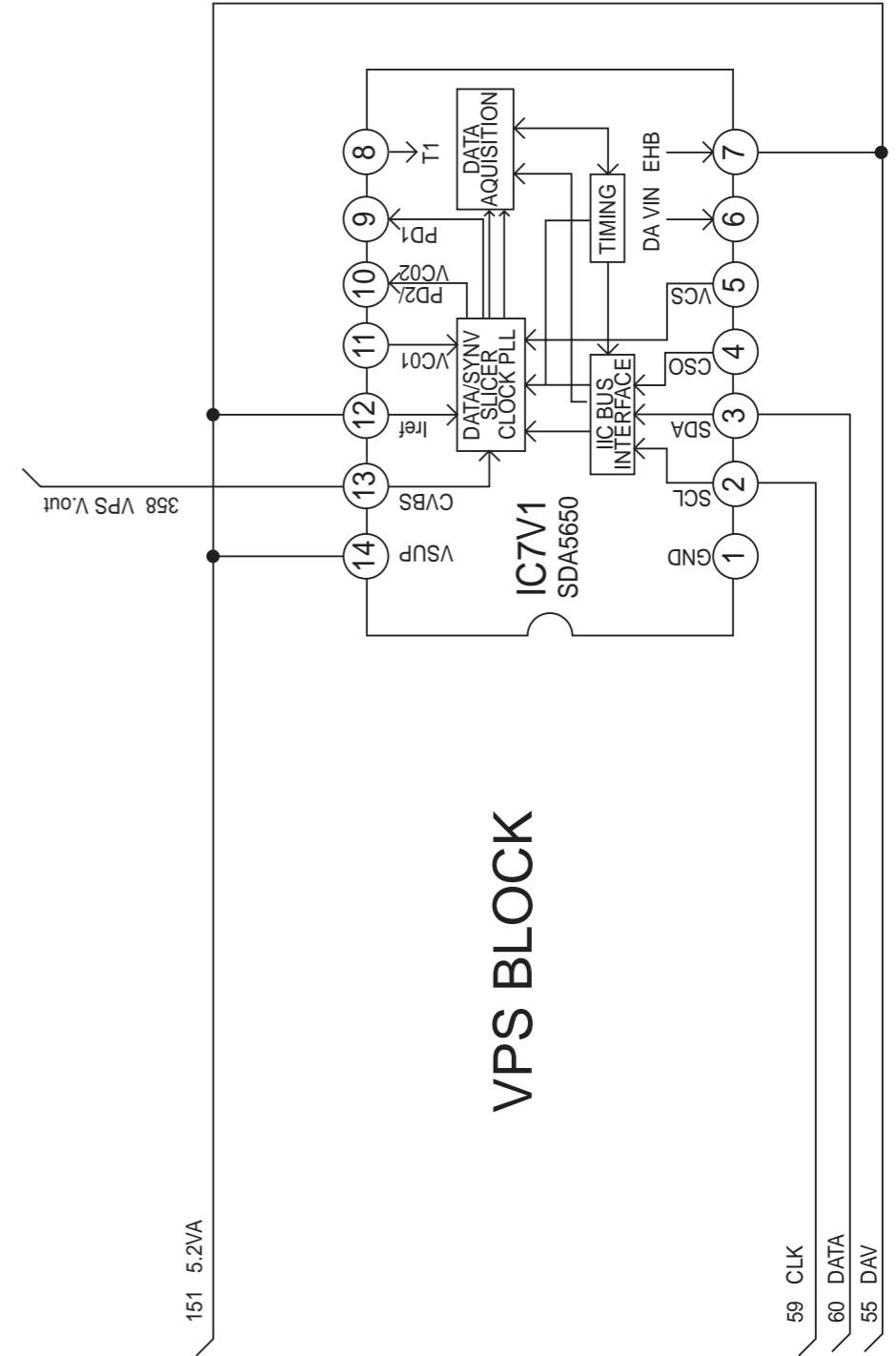

5. Y/C BLOCK DIAGRAM
(PB MODE)

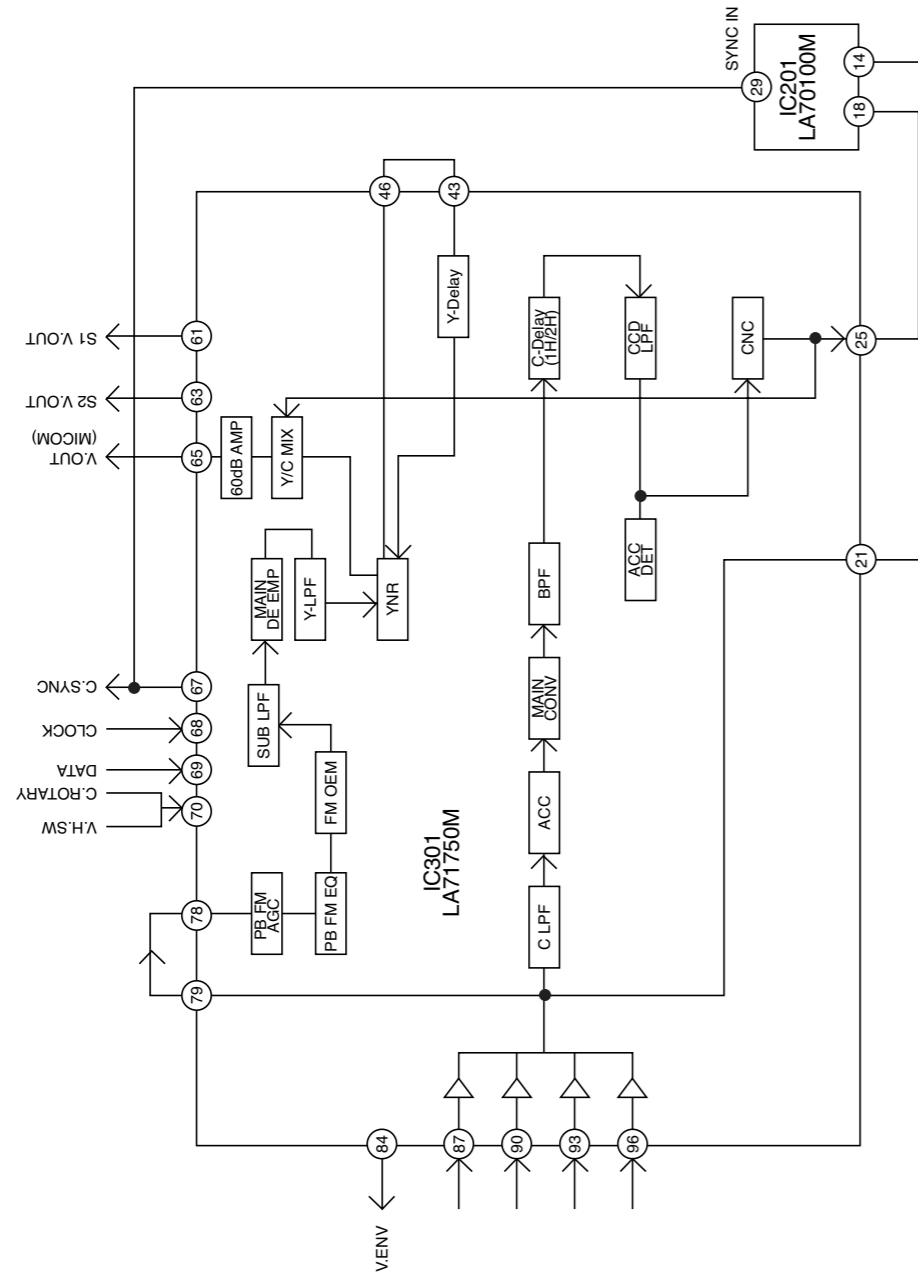

(REC MODE)

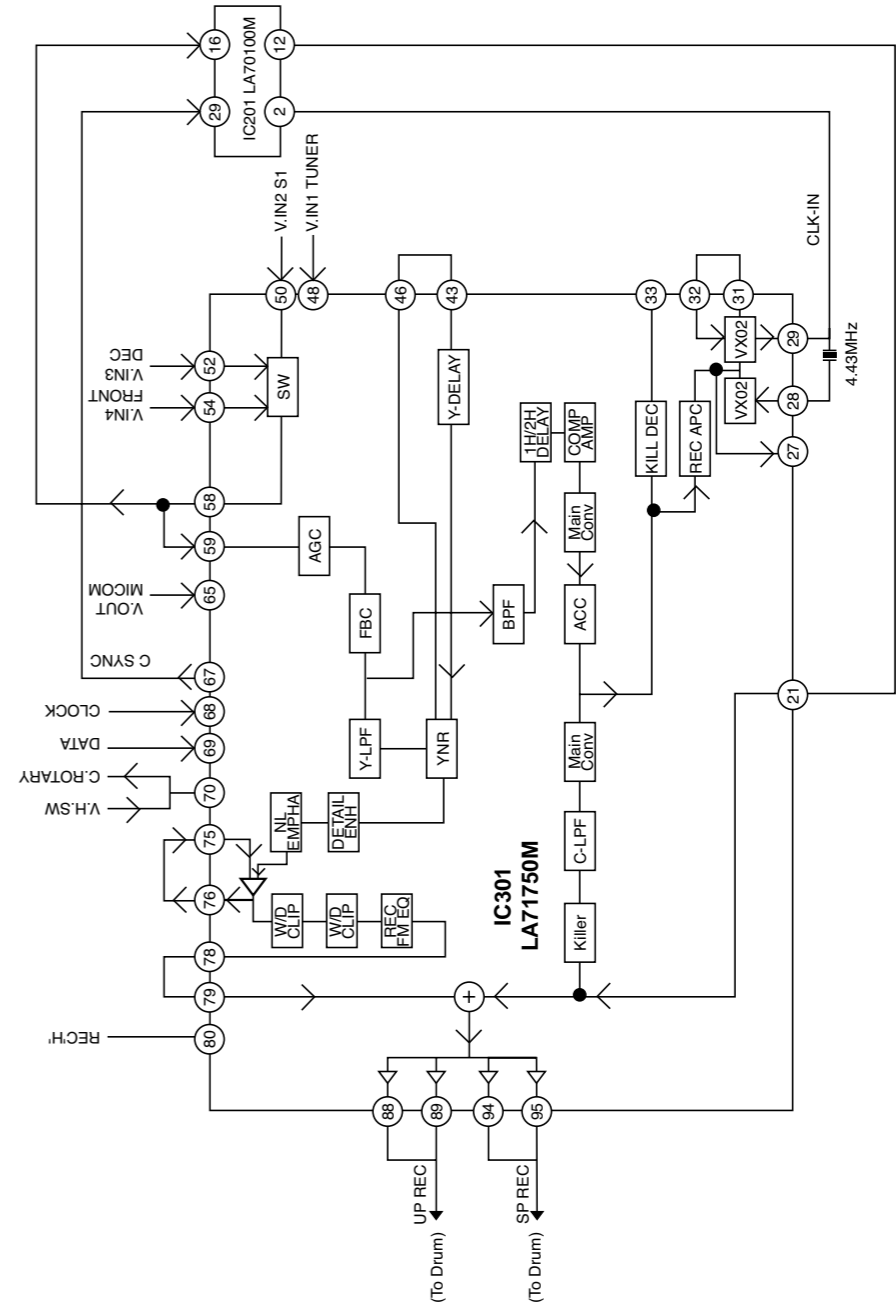

6. Hi-Fi BLOCK DIAGRAM

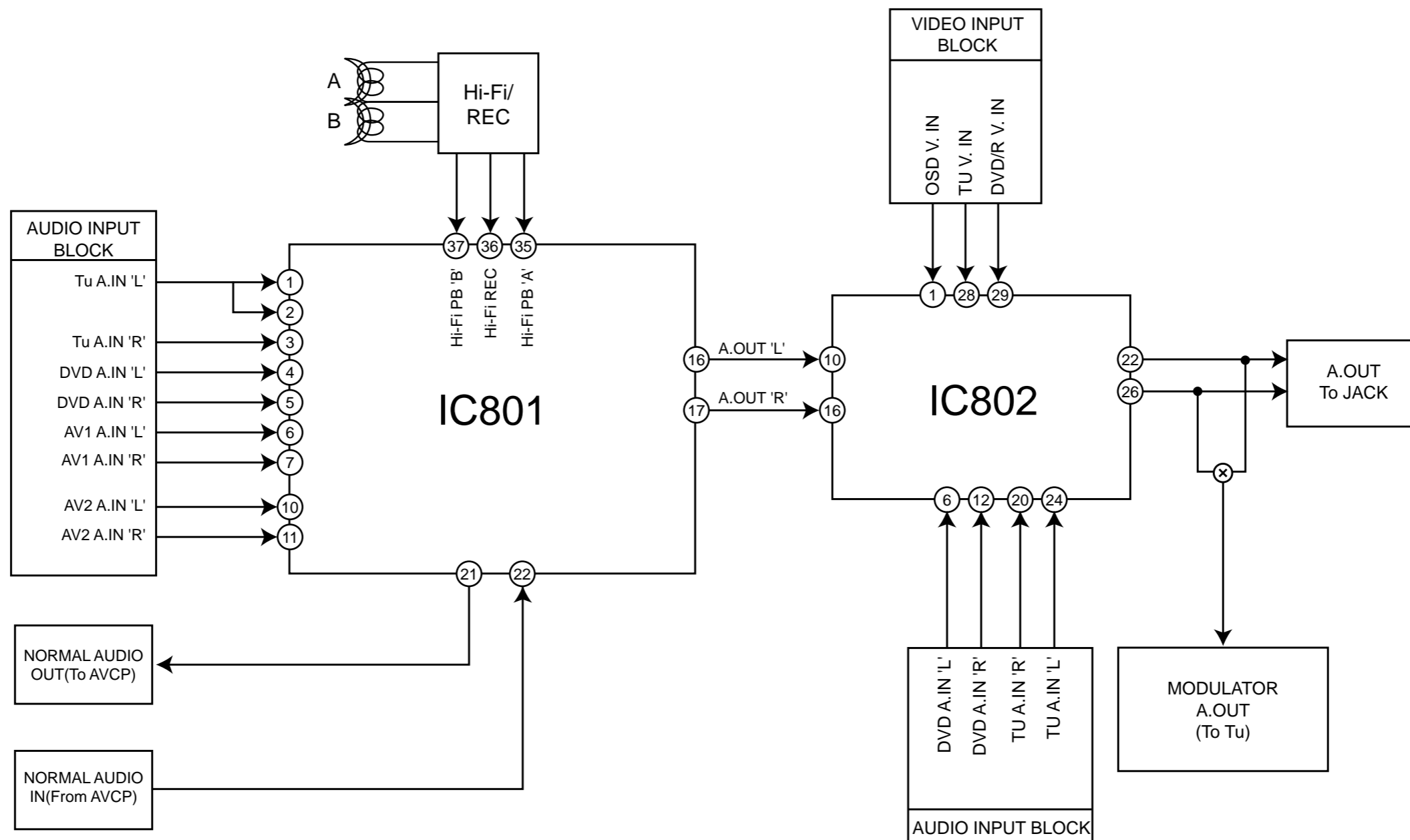

7. SYSTEM BLOCK DIAGRAM

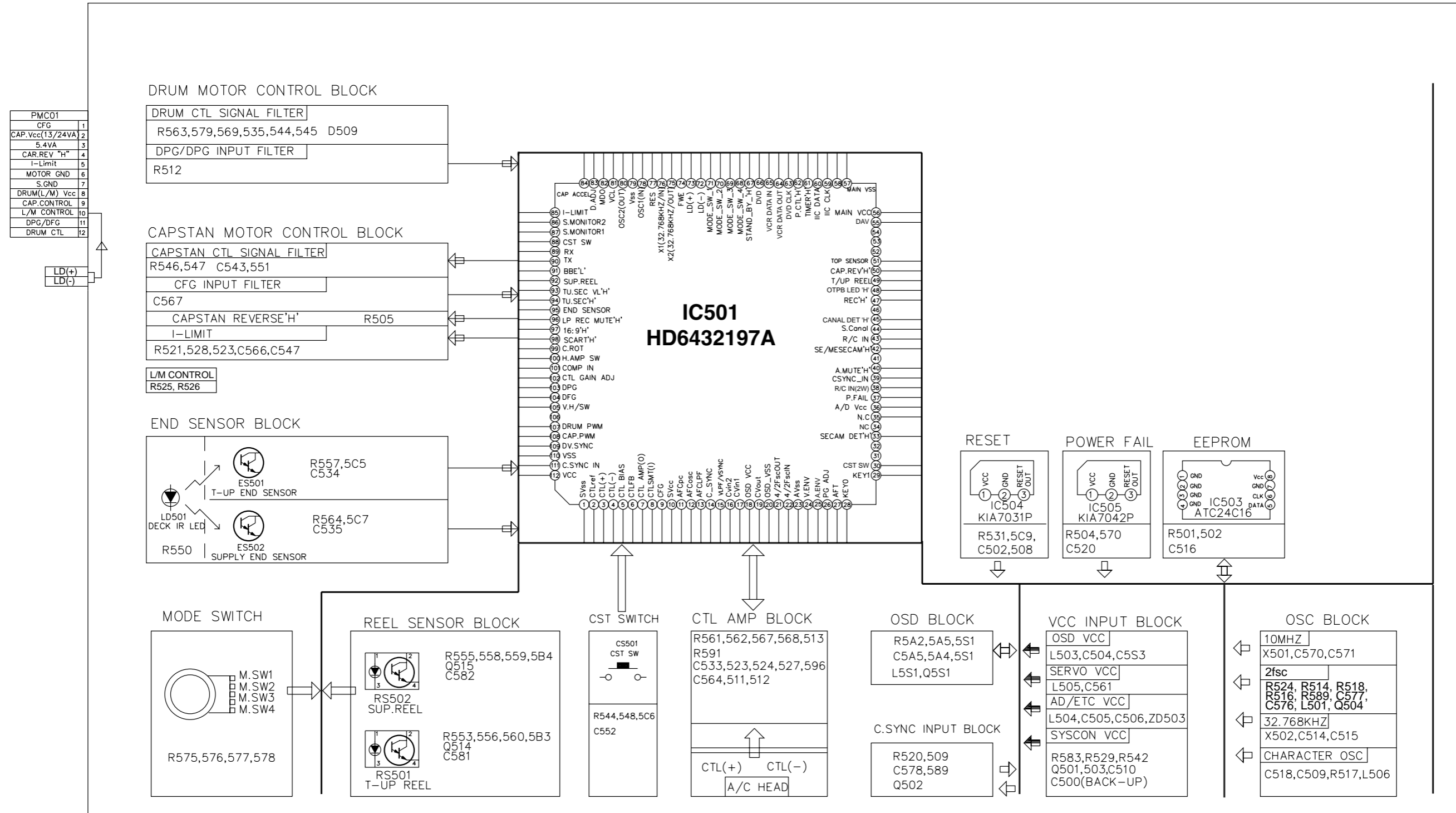

CIRCUIT DIAGRAMS

1. POWER(SMPS) CIRCUIT DIAGRAM 1_200W

IMPORTANT SAFETY NOTICE

WHEN SERVICING THIS CHASSIS, UNDER NO CIRCUMSTANCES SHOULD THE ORIGINAL DESIGN BE MODIFIED OR ALTERED WITHOUT PERMISSION FROM THE LG ELECTRONICS CORPORATION. ALL COMPONENTS SHOULD BE REPLACED ONLY WITH TYPES IDENTICAL TO THOSE IN THE ORIGINAL CIR-

CUIT. SPECIAL COMPONENTS ARE SHADED ON THE SCHEMATIC FOR EASY IDENTIFICATION. THIS CIRCUIT DIAGRAM MAY OCCASIONALLY DIFFER FROM THE ACTUAL CIRCUIT USED. THIS WAY, IMPLEMENTATION OF THE LATEST SAFETY AND PERFORMANCE IMPROVEMENT CHANGES INTO THE SET IS NOT DELAYED UNTIL THE NEW SERVICE LITERATURE IS PRINTED.

NOTE :

1. Shaded(■) parts are critical for safety. Replace only with specified part number.
2. Voltages are DC-measured with a digital voltmeter during Play mode.

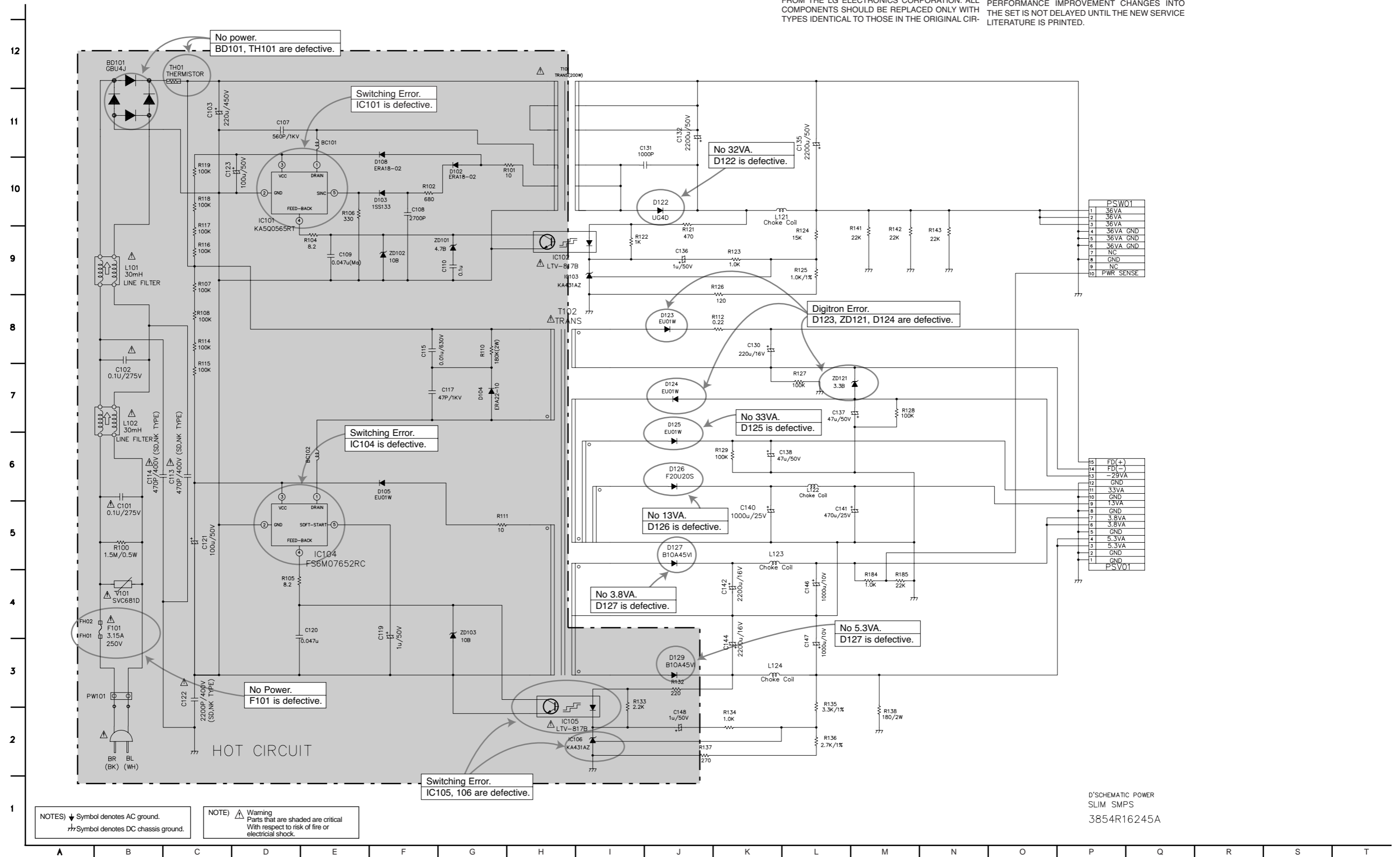

2. POWER(SMPS) CIRCUIT DIAGRAM 1_400W

IMPORTANT SAFETY NOTICE

WHEN SERVICING THIS CHASSIS, UNDER NO CIRCUMSTANCES SHOULD THE ORIGINAL DESIGN BE MODIFIED OR ALTERED WITHOUT PERMISSION FROM THE LG ELECTRONICS CORPORATION. ALL COMPONENTS SHOULD BE REPLACED ONLY WITH TYPES IDENTICAL TO THOSE IN THE ORIGINAL CIR-

CUIT. SPECIAL COMPONENTS ARE SHADED ON THE SCHEMATIC FOR EASY IDENTIFICATION. THIS CIRCUIT DIAGRAM MAY OCCASIONALLY DIFFER FROM THE ACTUAL CIRCUIT USED. THIS WAY, IMPLEMENTATION OF THE LATEST SAFETY AND PERFORMANCE IMPROVEMENT CHANGES INTO THE SET IS NOT DELAYED UNTIL THE NEW SERVICE LITERATURE IS PRINTED.

NOTE :

1. Shaded(■) parts are critical for safety. Replace only with specified part number.
2. Voltages are DC-measured with a digital voltmeter during Play mode.

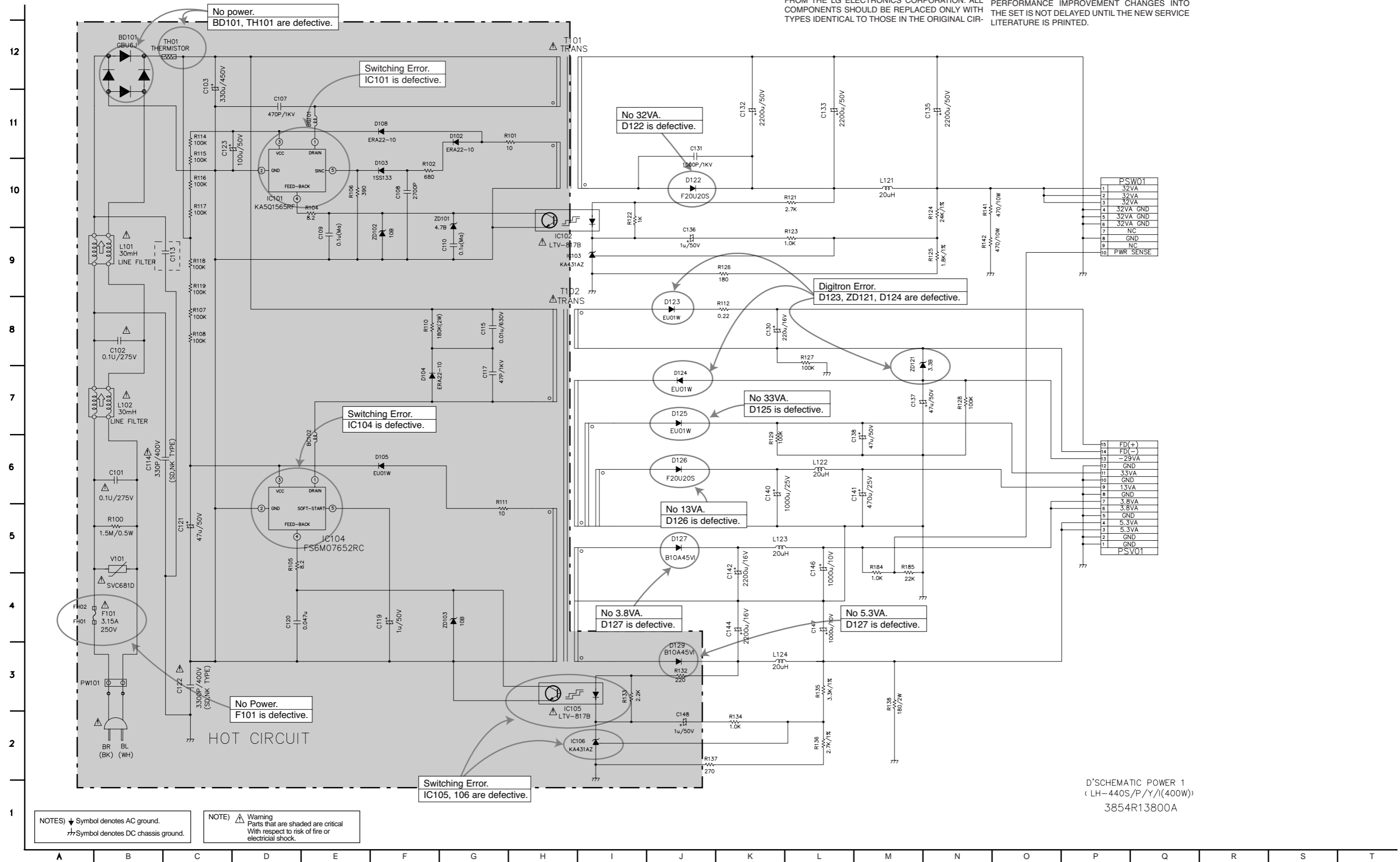

D'SCHEMATIC POWER 1
(LH-440S/P/Y/I(400W))
3854R13800A

3. POWER(SMPS) CIRCUIT DIAGRAM 2

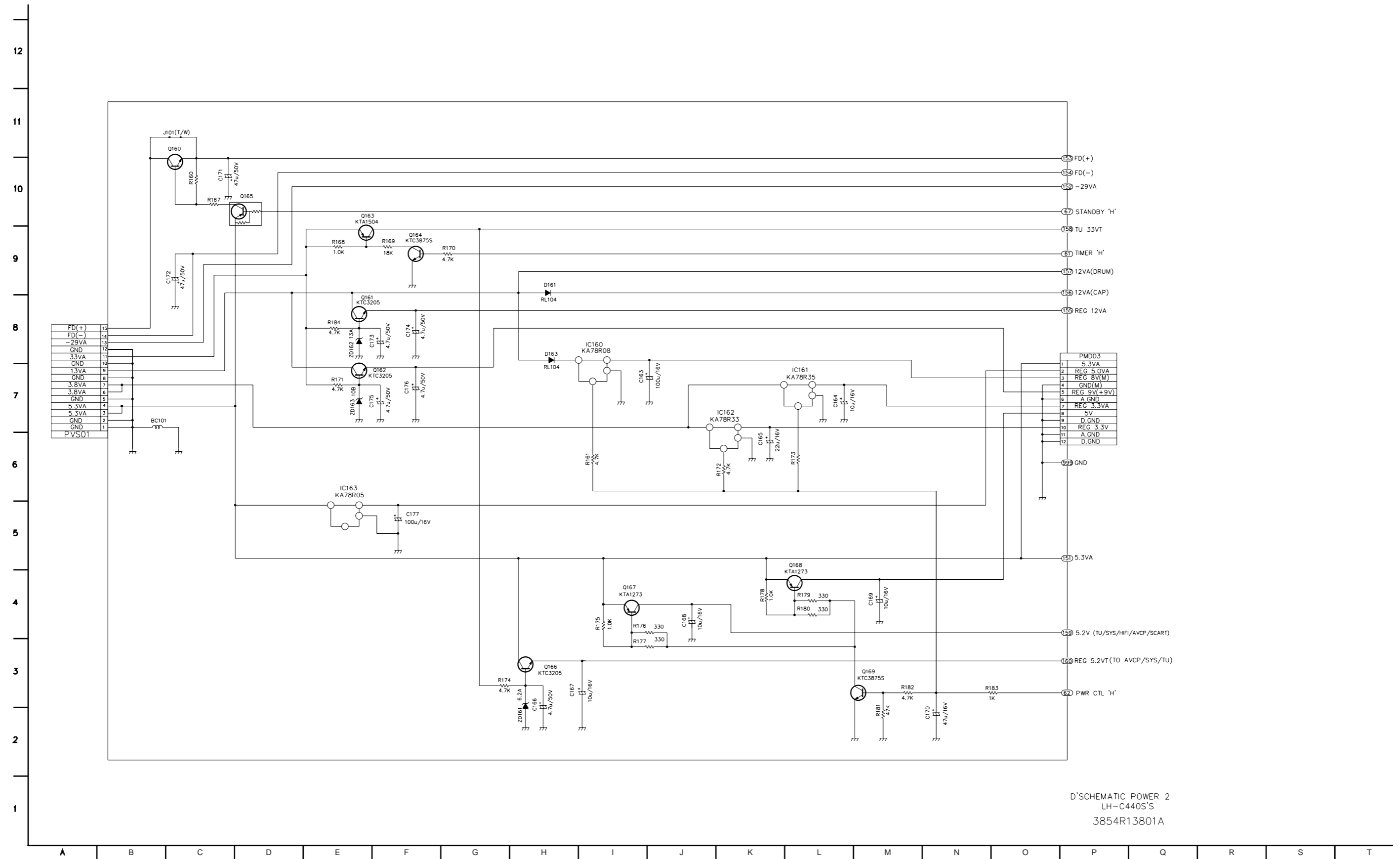

D'SCHEMATIC POWER 2
LH-C440S'S
3854R13801A

4. TU/IF, NICAM & A2 CIRCUIT DIAGRAM

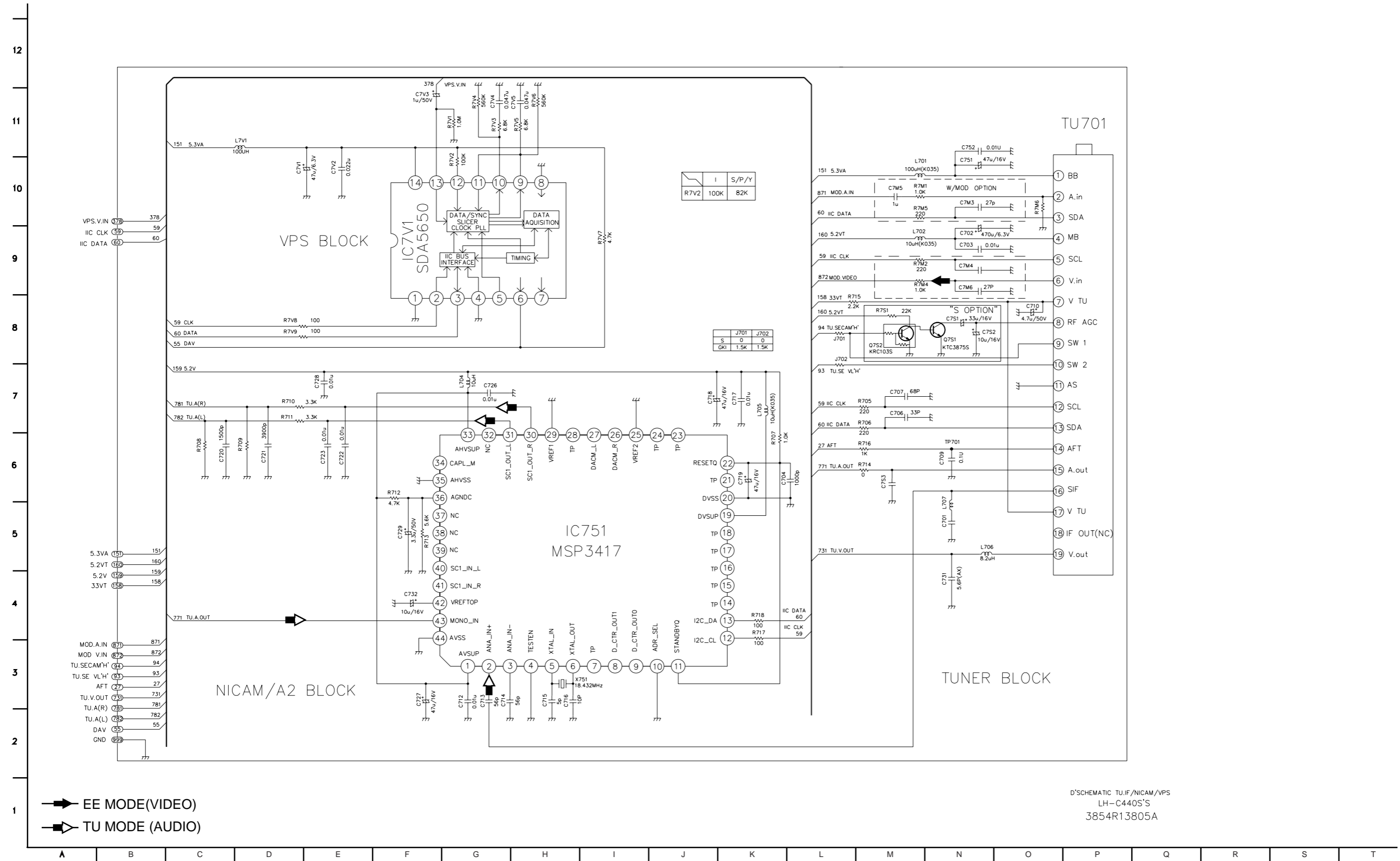

D'SCHEMATIC TU/IF/NICAM/VPS
LH-C440S'S
3854R13805A

5. A/V CIRCUIT DIAGRAM

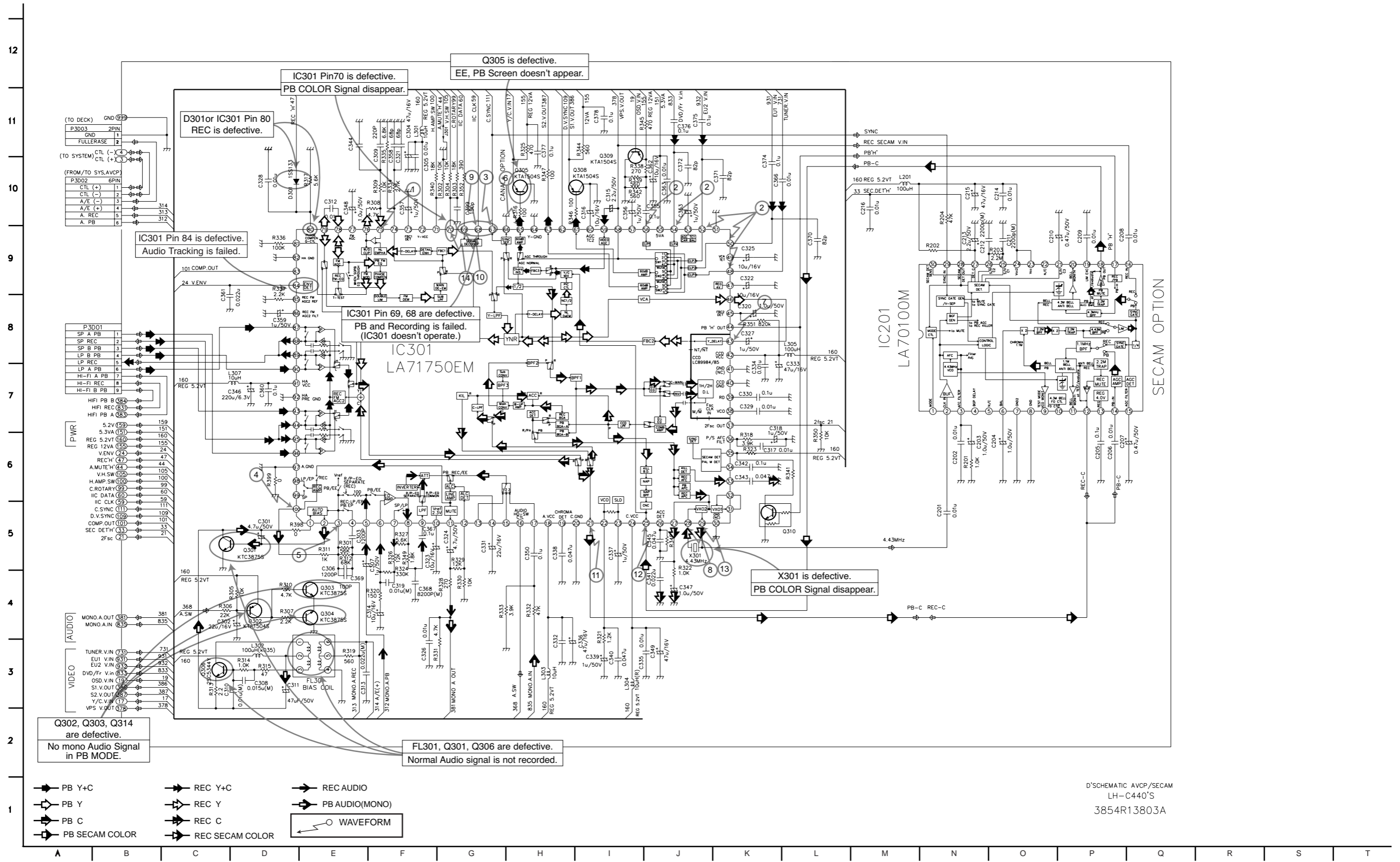

Q302, Q303, Q314
are defective.
No mono Audio Signal
in PB MODE.

IC301 Pin70 is defective.
PB COLOR Signal disappear.

Q305 is defective.
EE, PB Screen doesn't appear.

IC301 Pin 69, 68 are defective.
PB and Recording is failed.
(IC301 doesn't operate.)

X301 is defective.
PB COLOR Signal disappear.

FL301, Q301, Q306 are defective.
Normal Audio signal is not recorded.

SECAM OPTION

- ➔ PB Y+C
- ➔ REC Y+C
- ➔ REC AUDIO
- ➔ PB Y
- ➔ REC Y
- ➔ PB AUDIO(MONO)
- ➔ PB C
- ➔ REC C
- ➔ PB SECAM COLOR
- ➔ REC SECAM COLOR
- WAVEFORM

D'SCHEMATIC AVCP/SECAM
LH-C440'S
3854R13803A

6. Hi-Fi CIRCUIT DIAGRAM

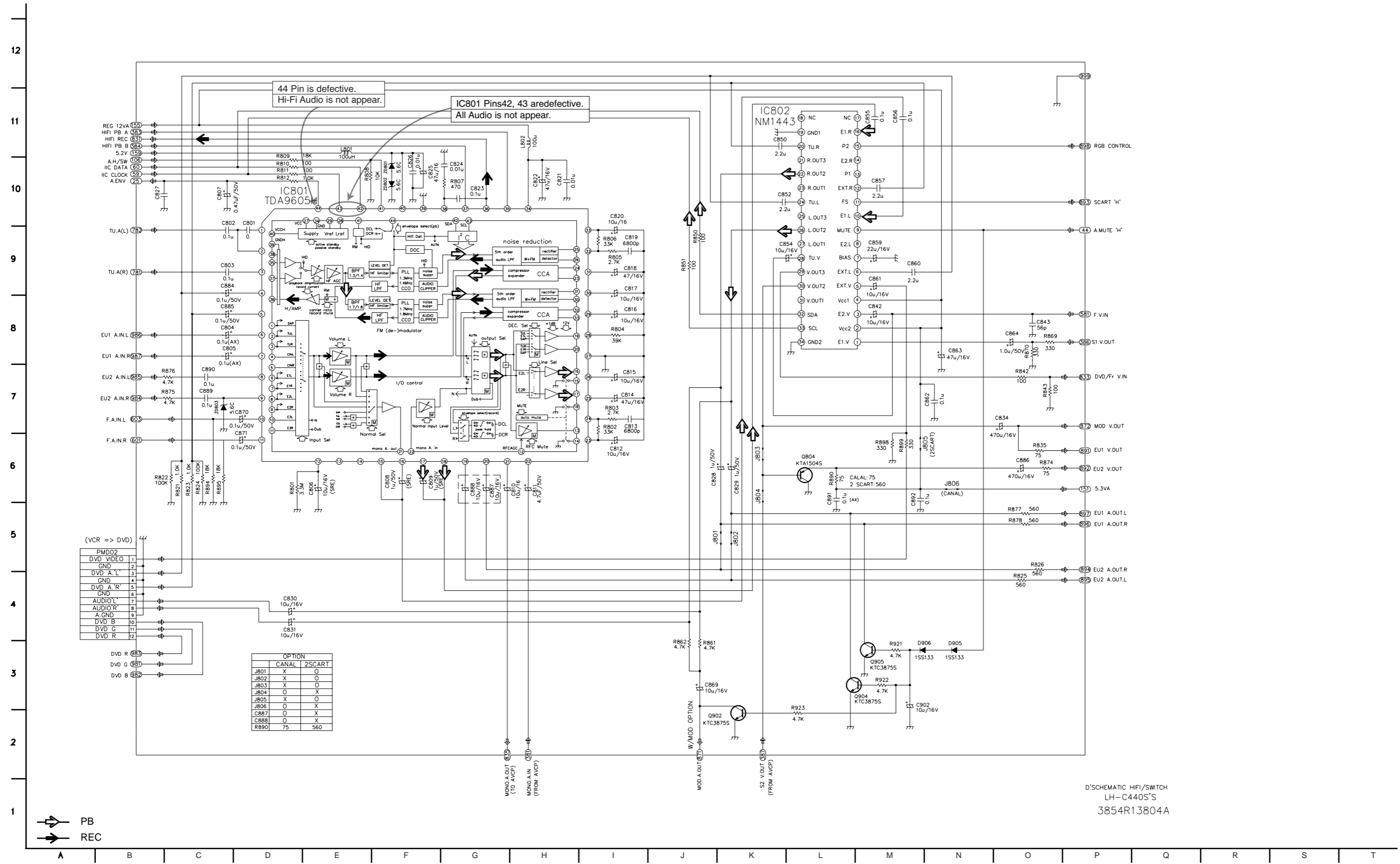

7. SCART(JACK) CIRCUIT DIAGRAM

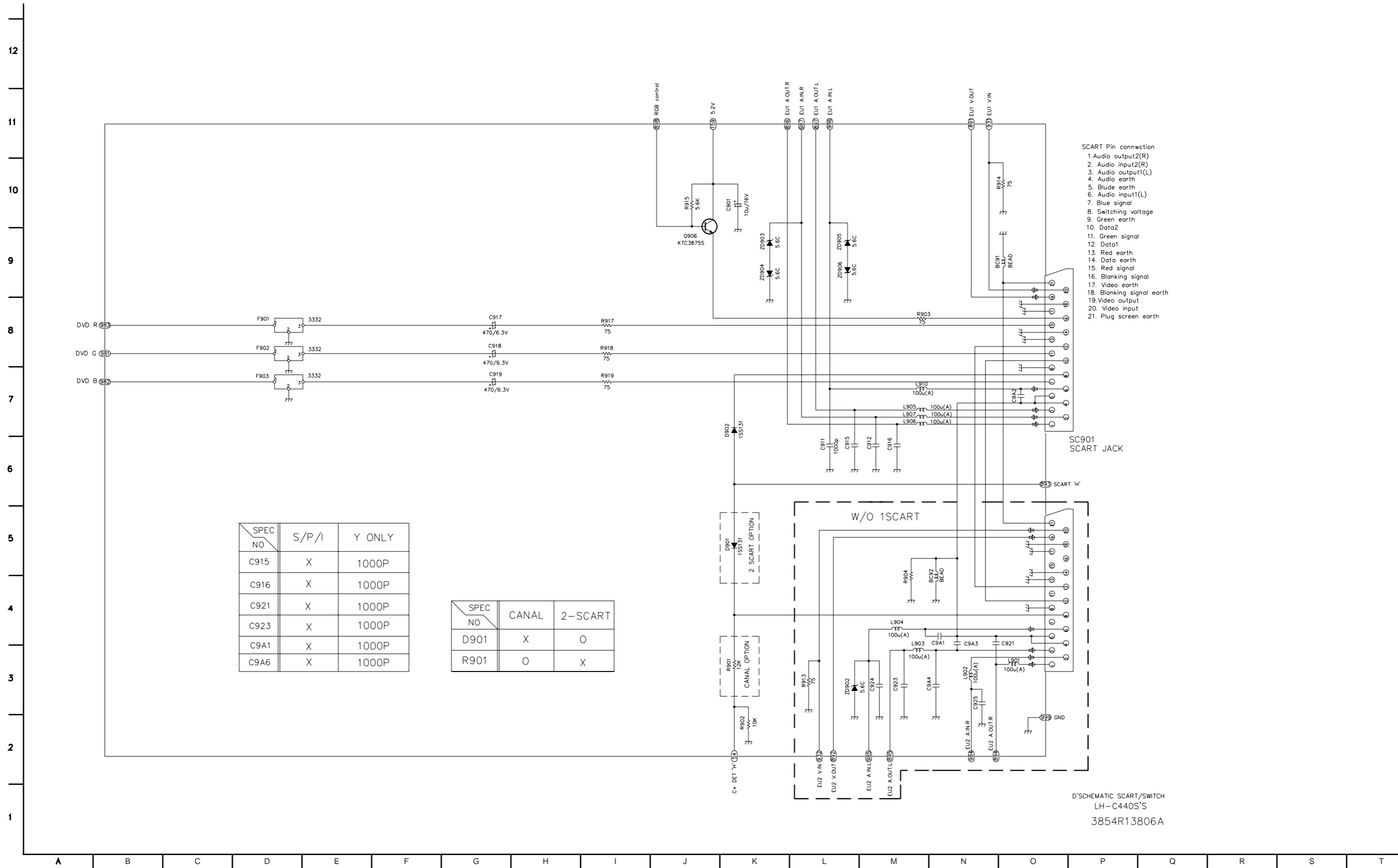

- SCART Pin connection
1. Audio output2(R)
 2. Audio input2(R)
 3. Audio output1(L)
 4. Audio earth
 5. Blue earth
 6. Audio input1(L)
 7. Blue signal
 8. Switching voltage
 9. Green earth
 10. Data2
 11. Green signal
 12. Data1
 13. Red earth
 14. Data earth
 15. Red signal
 16. Blanking signal
 17. Video earth
 18. Blanking signal earth
 19. Video output
 20. Video input
 21. Plug screen earth

SPEC NO	S/P/I	Y ONLY
C915	X	1000P
C916	X	1000P
C921	X	1000P
C923	X	1000P
C9A1	X	1000P
C9A6	X	1000P

SPEC NO	CANAL	2-SCART
D901	X	O
R901	O	X

D'SCHEMATIC SCART/SWITCH
LH-C440S'S
3854R13806A

8. SYSTEM CIRCUIT DIAGRAM

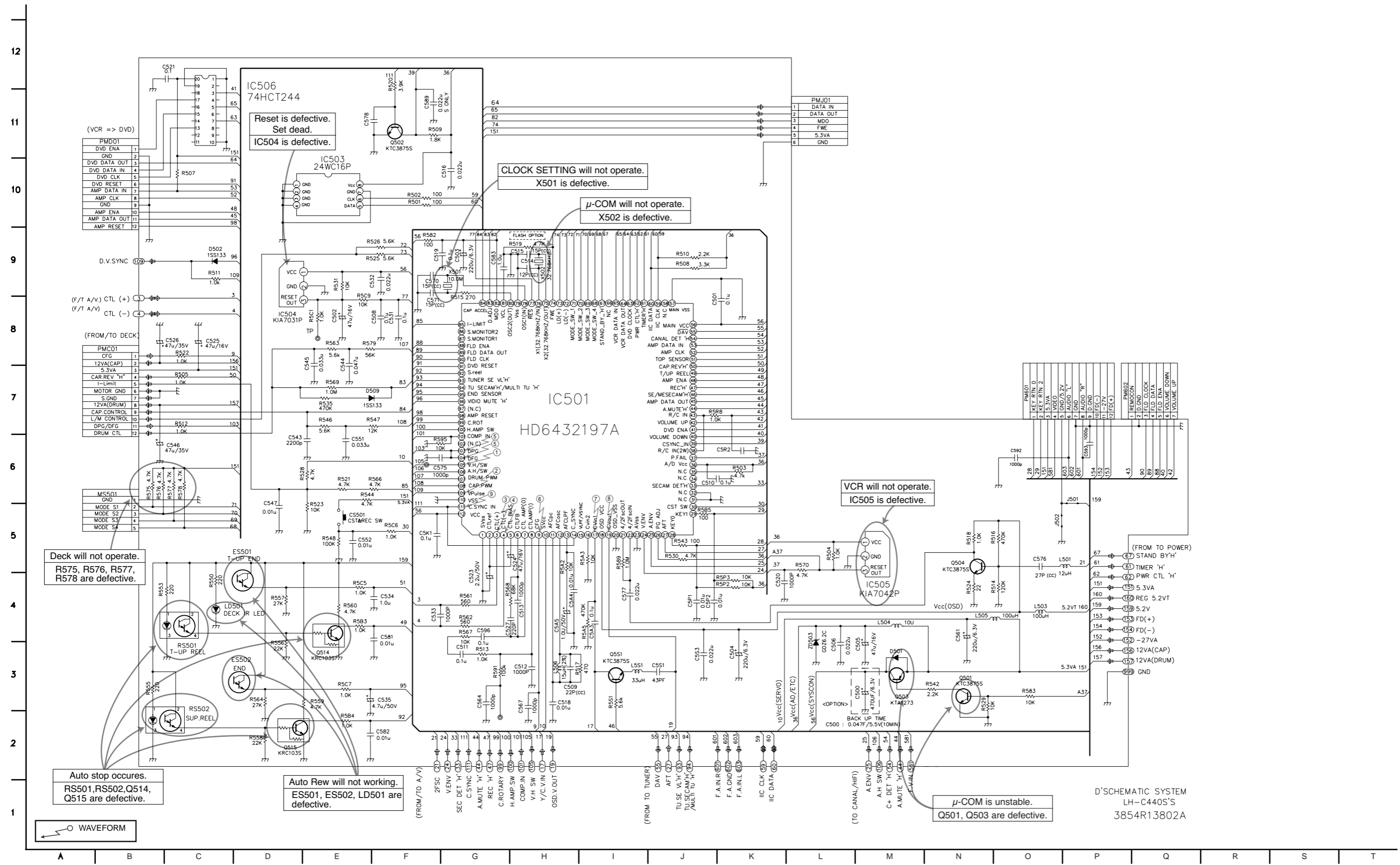

D'SCHEMATIC SYSTEM
LH-C440S'S
3854R13802A

9. TIMER CIRCUIT DIAGRAM_0TOOL

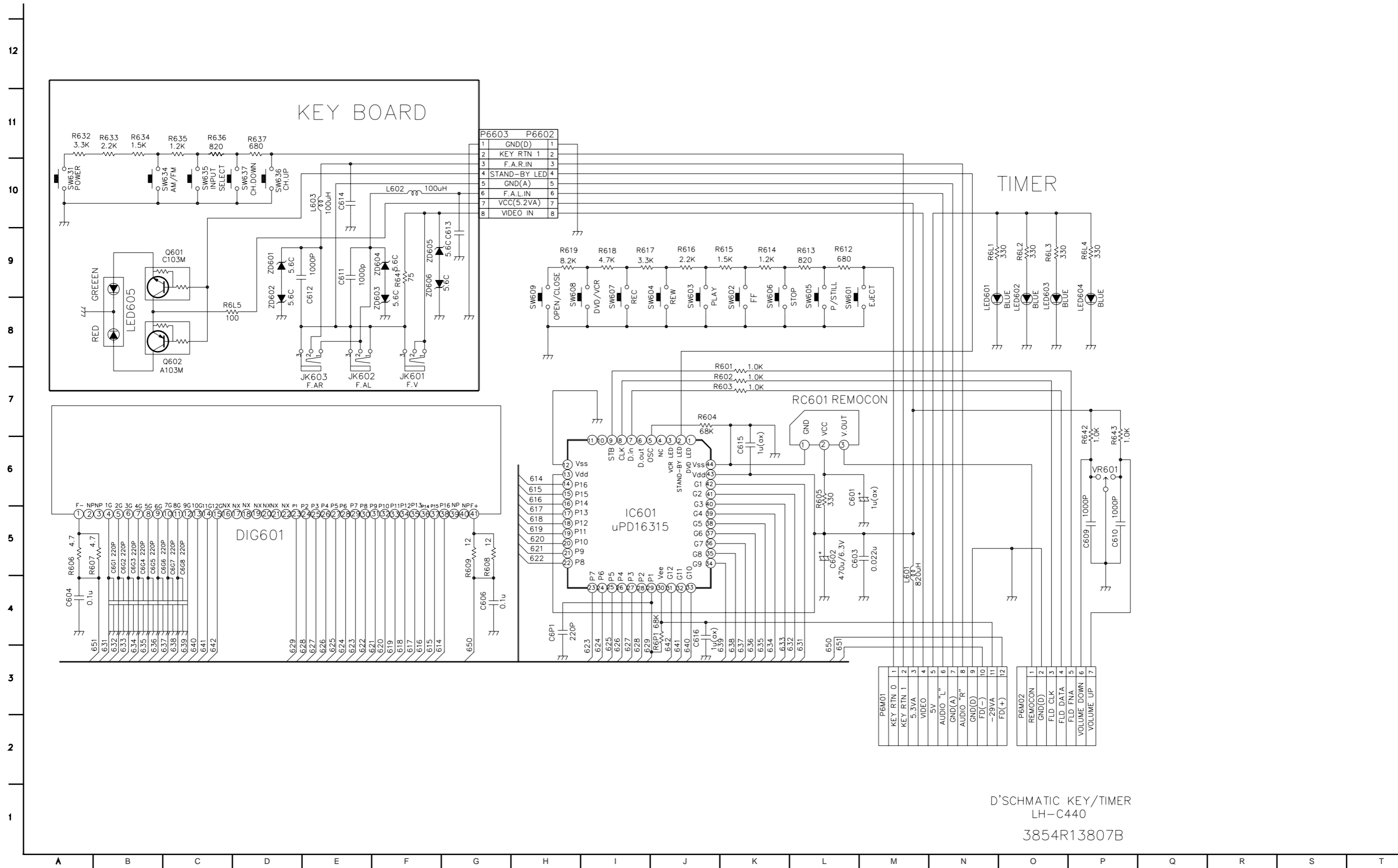

D'SCHMATIC KEY/TIMER
LH-C440
3854R13807B

10. TIMER CIRCUIT DIAGRAM_5TOOL / 7TOOL

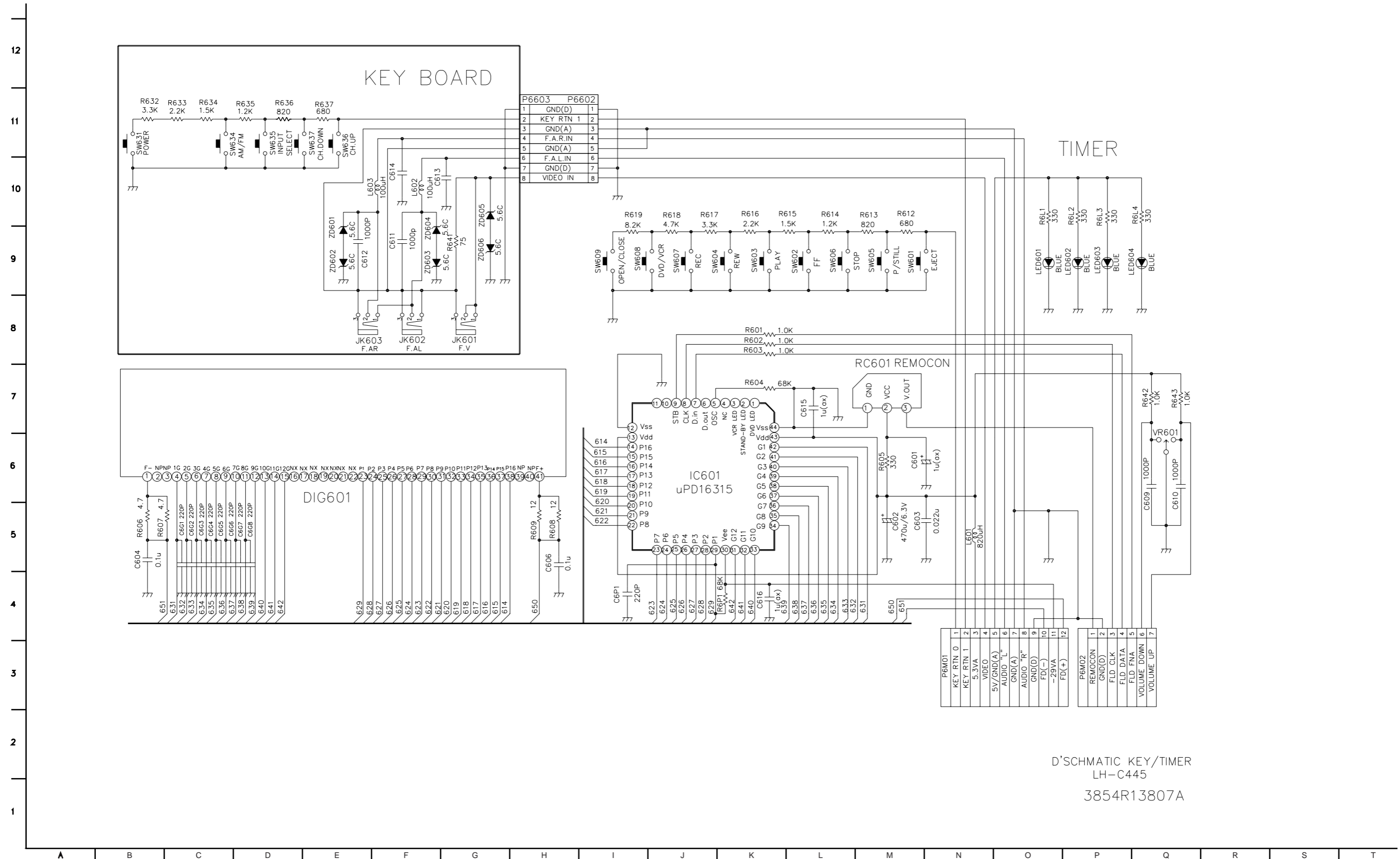

D'SCHMATIC KEY/TIMER
LH-C445
3854R13807A

11. TIMER CIRCUIT DIAGRAM_6TOOL

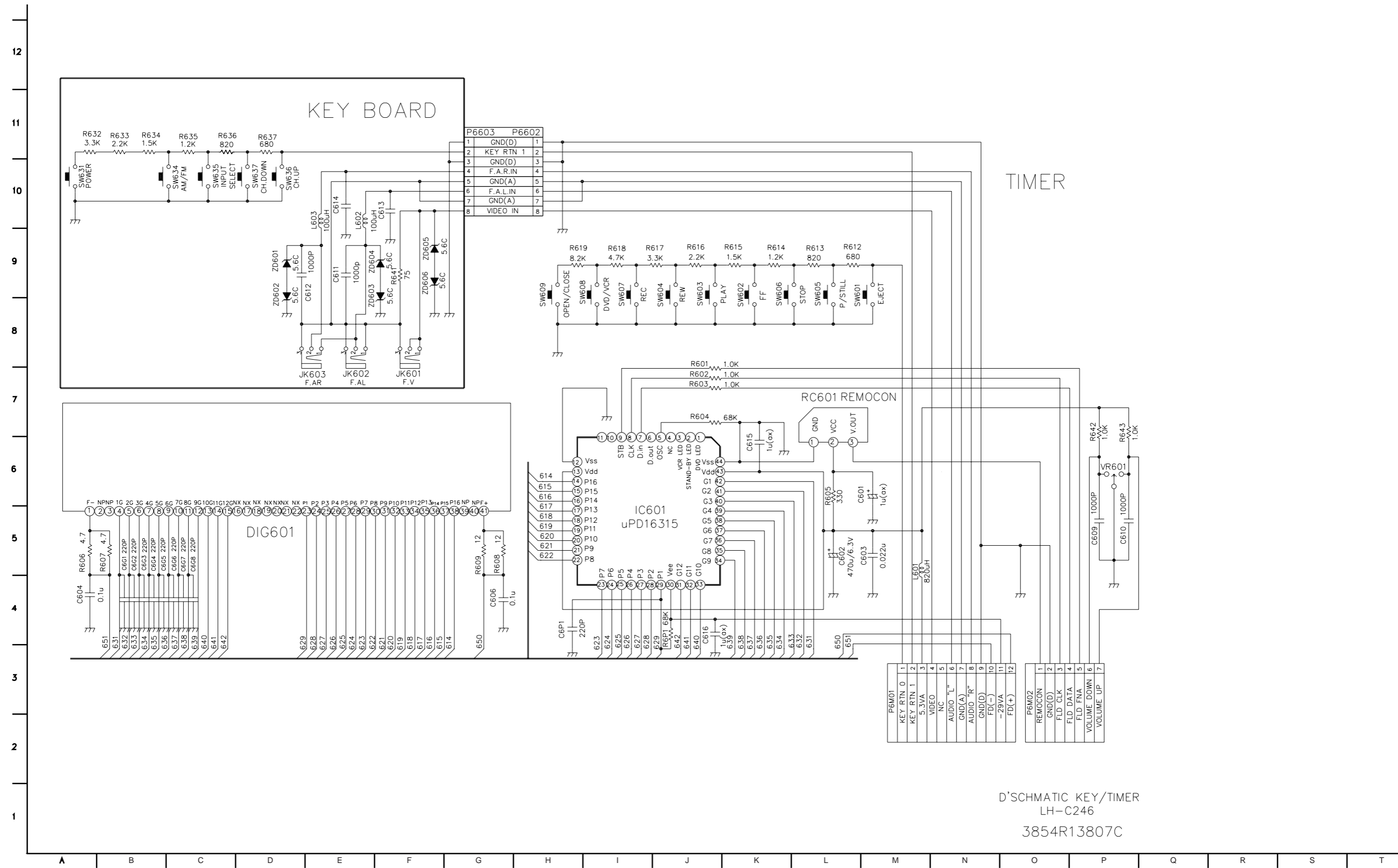

D'SCHMATIC KEY/TIMER
LH-C246
3854R13807C

WAVEFORM & VOLTAGE SHEET

★ IC301 Oscilloscope Waveform

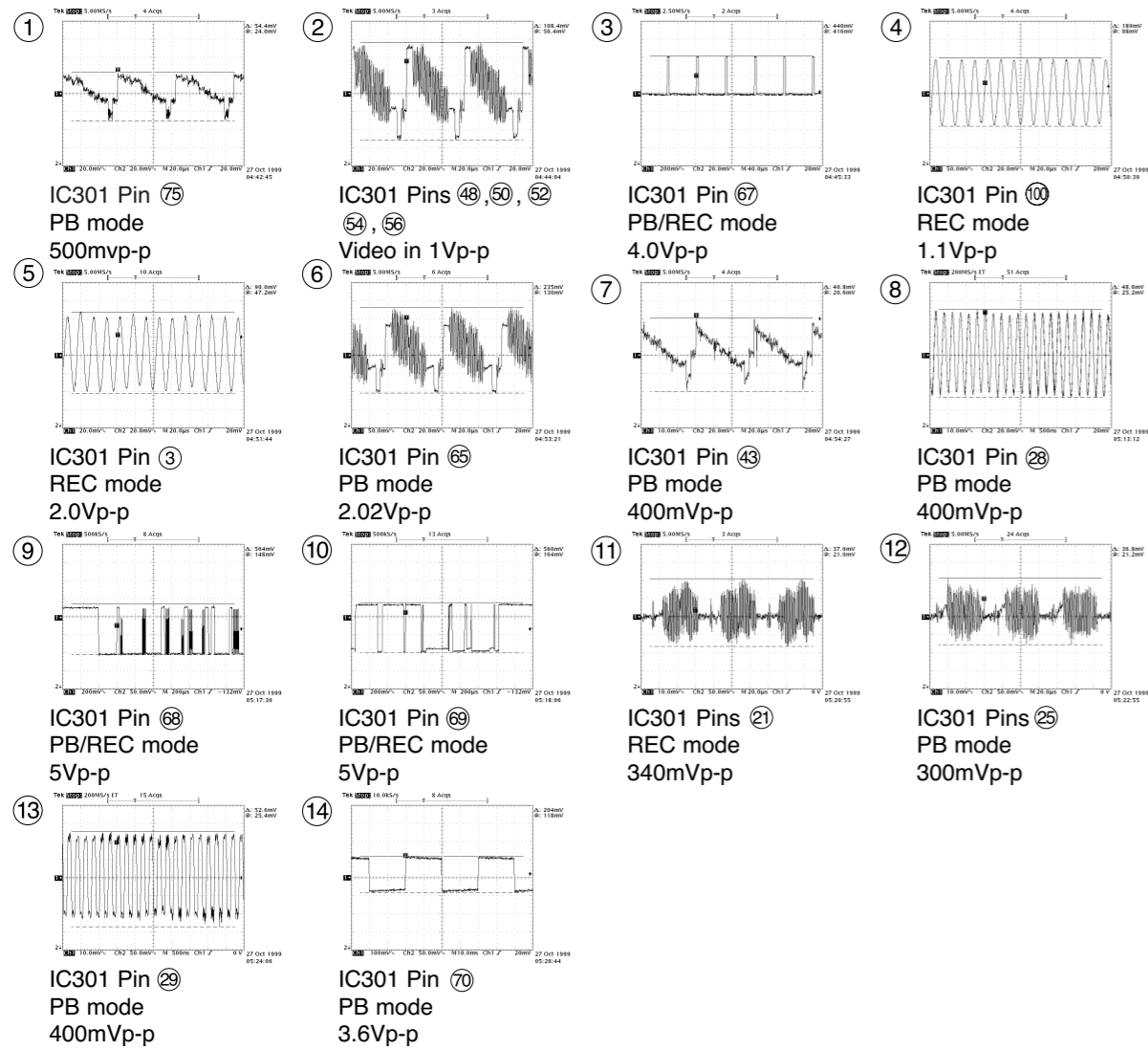

* IC501 Waveform Photographs

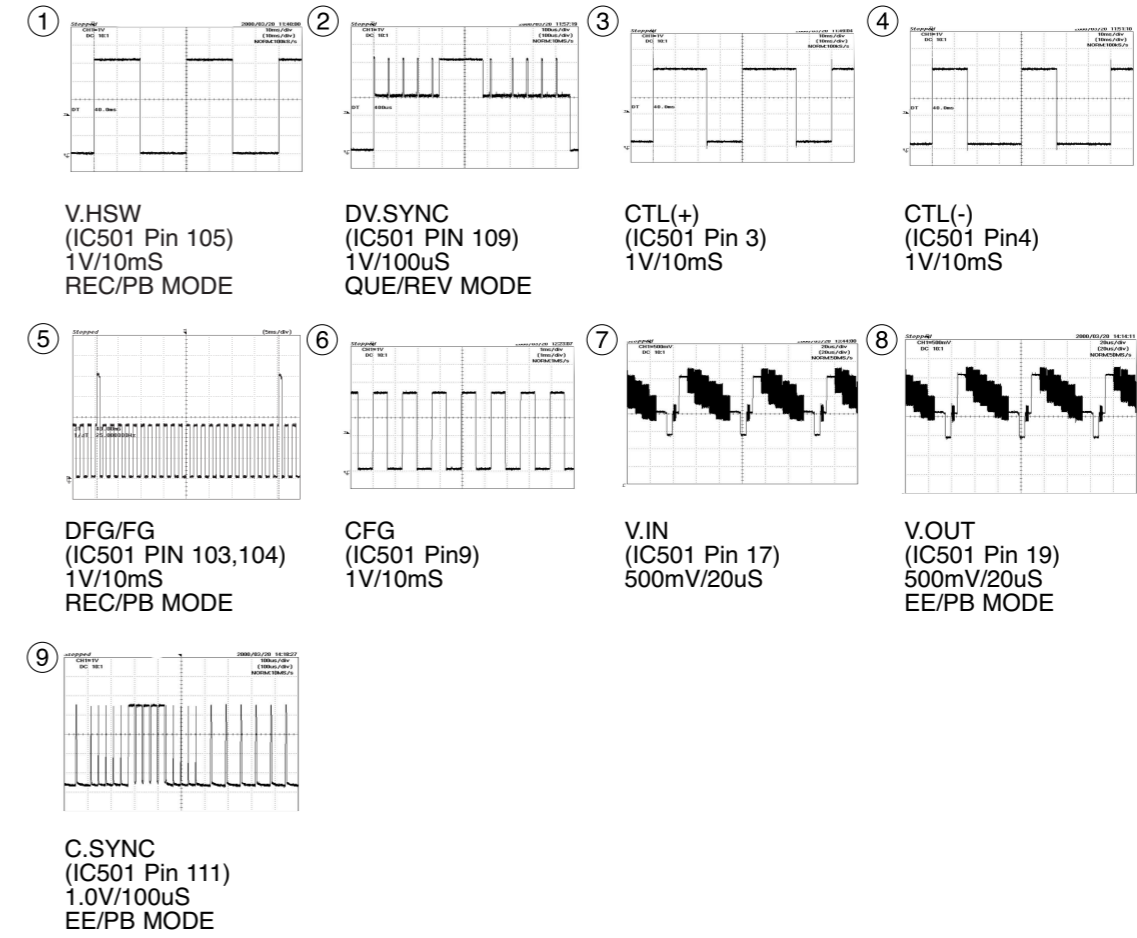

PRINTED CIRCUIT DIAGRAMS

1. MAIN P.C.BOARD

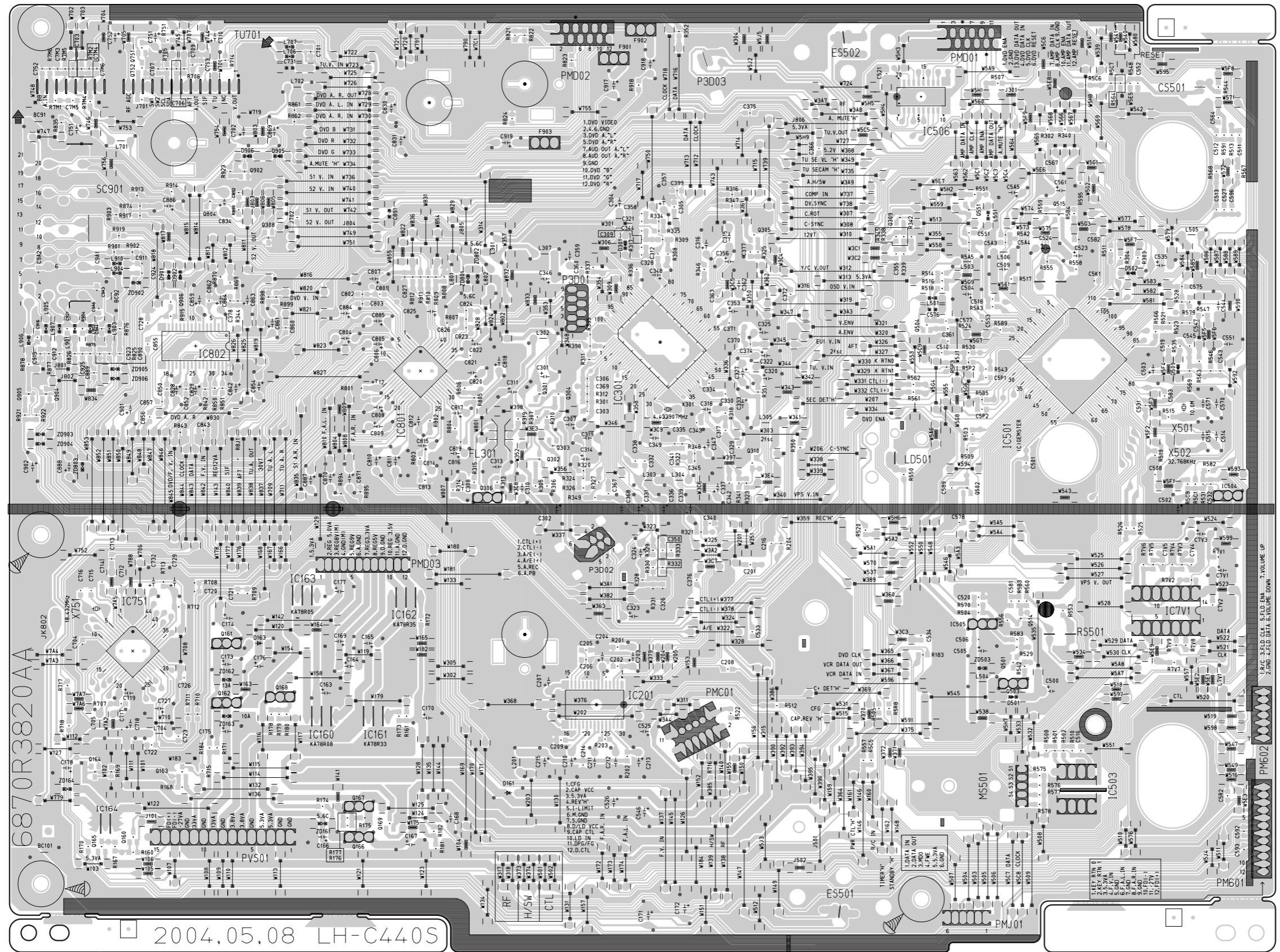

2004.05.08 LH-C440S

2. KEY(LEFT) P.C.BOARD

(0 TOOL)

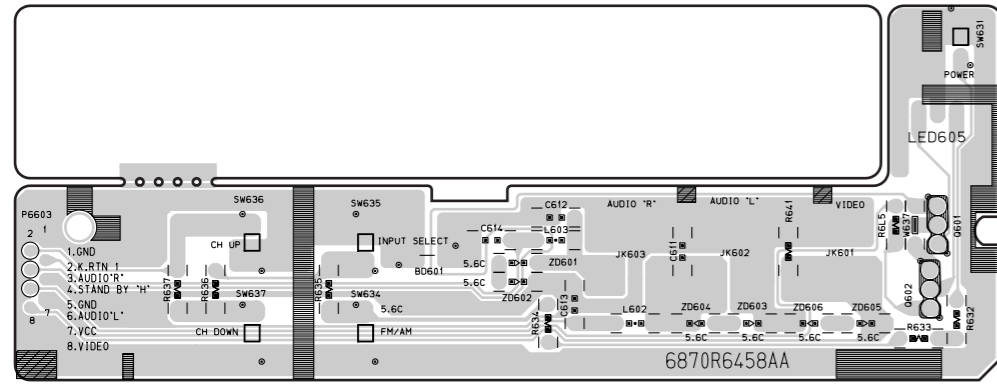

(5 TOOL / 7 TOOL)

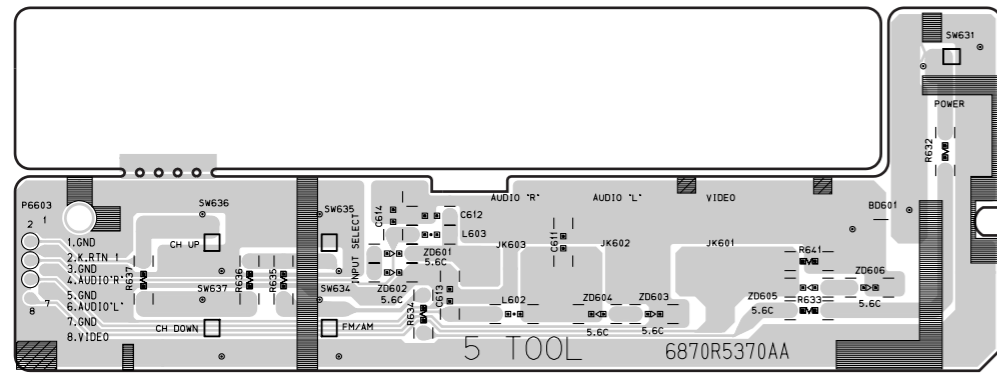

(6 TOOL)

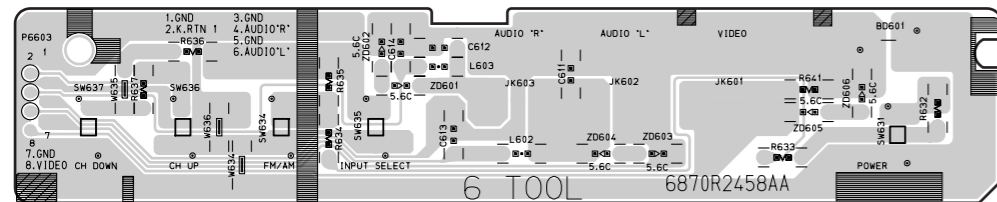

3. KEY(RIGHT) P.C.BOARD

(0 TOOL)

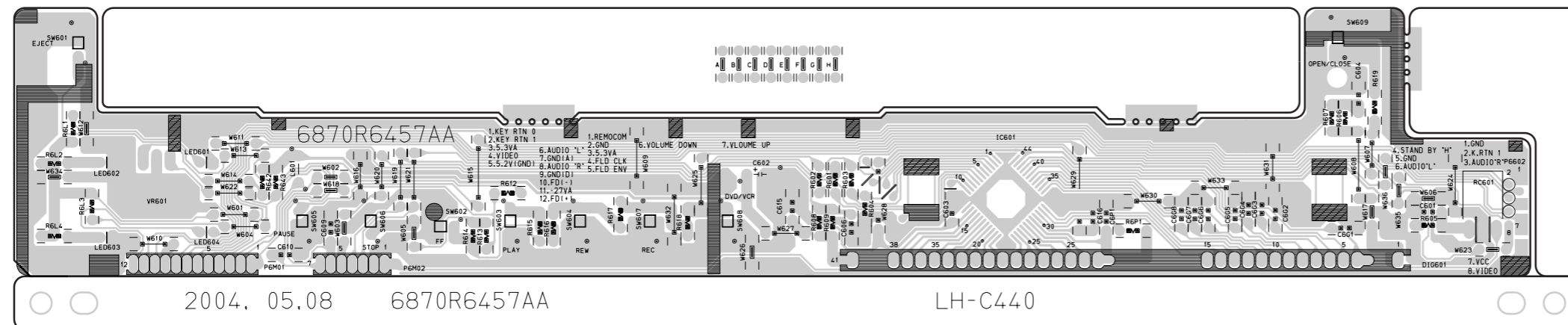

(5 TOOL / 7 TOOL)

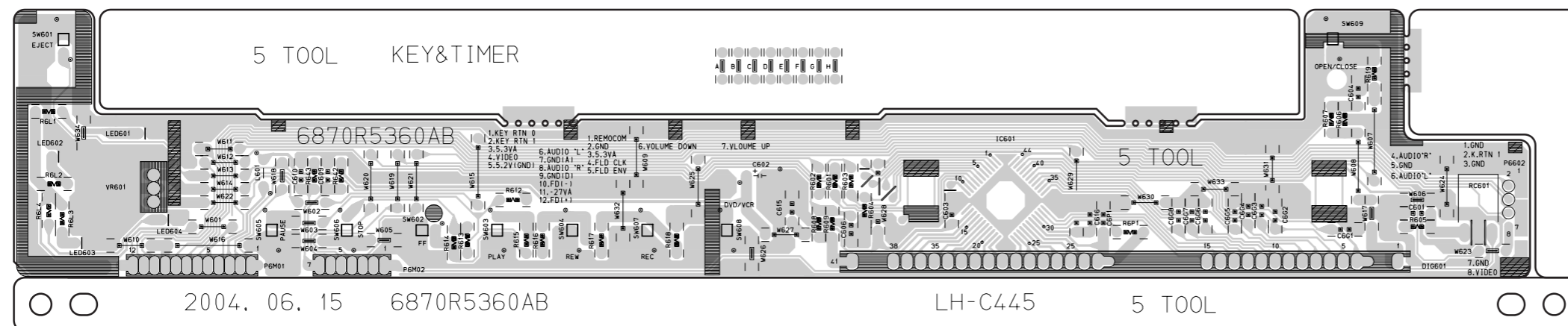

(6 TOOL)

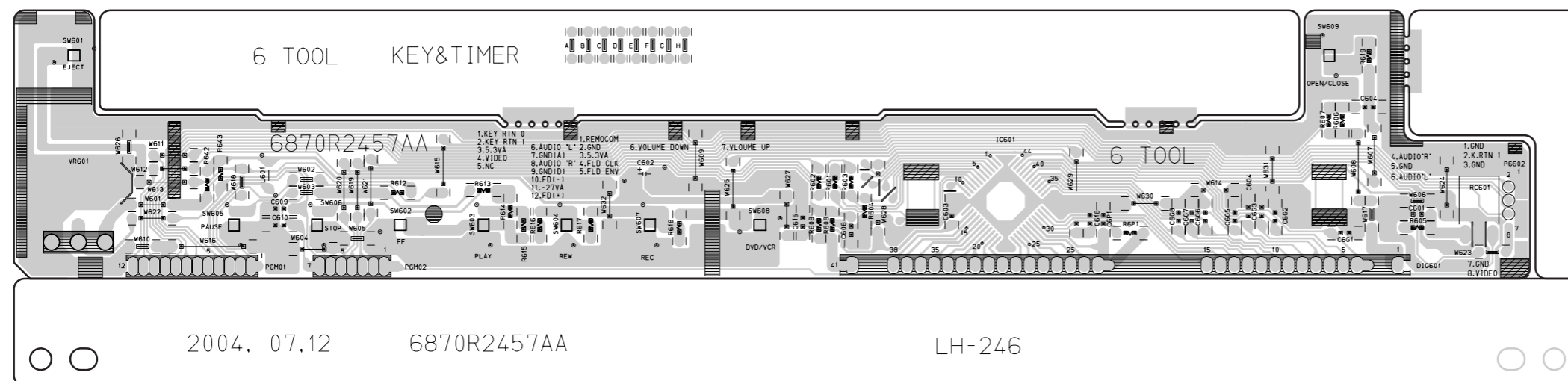

4. POWER P.C.BOARD

(0 TOOL)

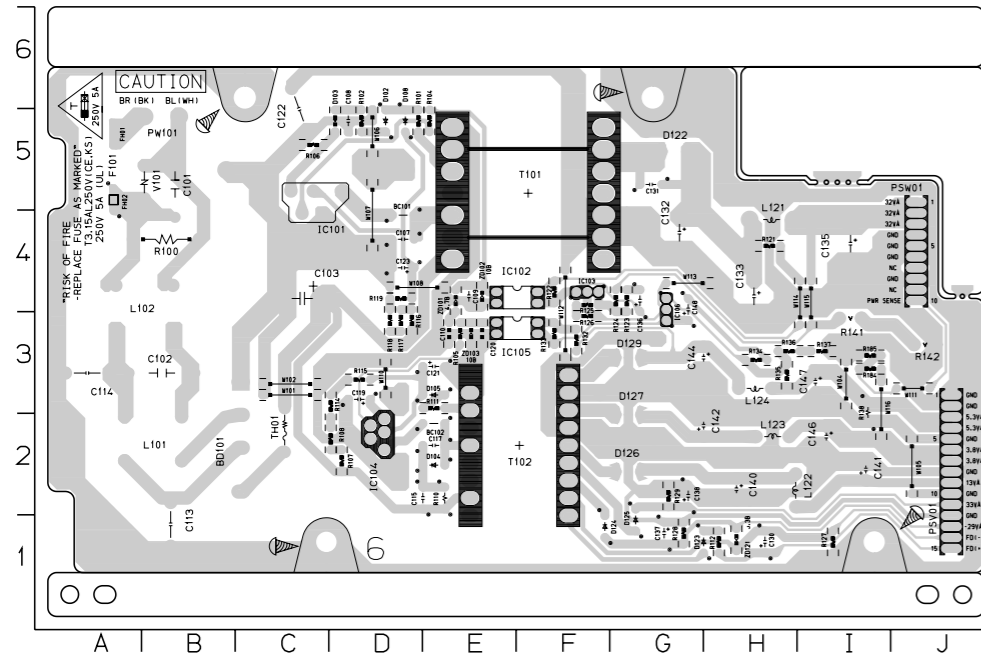

LOCATION GUIDE

BC101	D4	D104	E2	R111	E3
BC102	E2	D105	E3	R112	H1
BD101	B2	D108	D5	R114	D3
C101	B5	D122	G5	R115	D3
C102	B3	D123	H1	R116	D3
C103	C4	D124	F1	R117	D3
C107	D4	D125	G1	R118	D3
C108	D5	D126	G2	R119	D4
C109	E4	D127	G2	R121	H4
C110	E3	D129	G3	R122	F4
C113	B1	FH01	A5	R123	G4
C114	A3	FH02	A5	R124	G4
C115	E2	IC101	C5	R125	F4
C117	E2	IC102	F4	R126	F3
C119	D3	IC103	F4	R127	I1
C120	E3	IC104	D2	R128	G1
C121	E3	IC105	F3	R129	G2
C122	G5	IC106	G4	R132	F3
C123	D4	L101	B2	R133	F3
C130	H1	L102	B4	R134	H3
C131	G5	L121	H4	R135	H3
C132	G4	L122	H2	R136	H3
C133	H4	L123	H2	R137	I3
C135	I4	L124	H3	R138	I3
C136	G4	PSW01	J3	R141	I3
C137	G1	PSW01	J3	R142	J3
C138	G2	PW101	B5	R184	I3
C140	H2	R100	B4	R185	I3
C141	I2	R101	D5	T101	F5
C142	H2	R102	D5	T102	F2
C144	H3	R104	E5	TH01	C2
C146	I2	R105	E3	V101	B5
C147	I3	R106	C5	ZD101	E4
C148	G4	R107	D2	ZD102	E4
D102	D5	R108	D2	ZD103	E3
D103	D5	R110	E2	ZD121	H1

(5 TOOL / 6 TOOL / 7 TOOL)

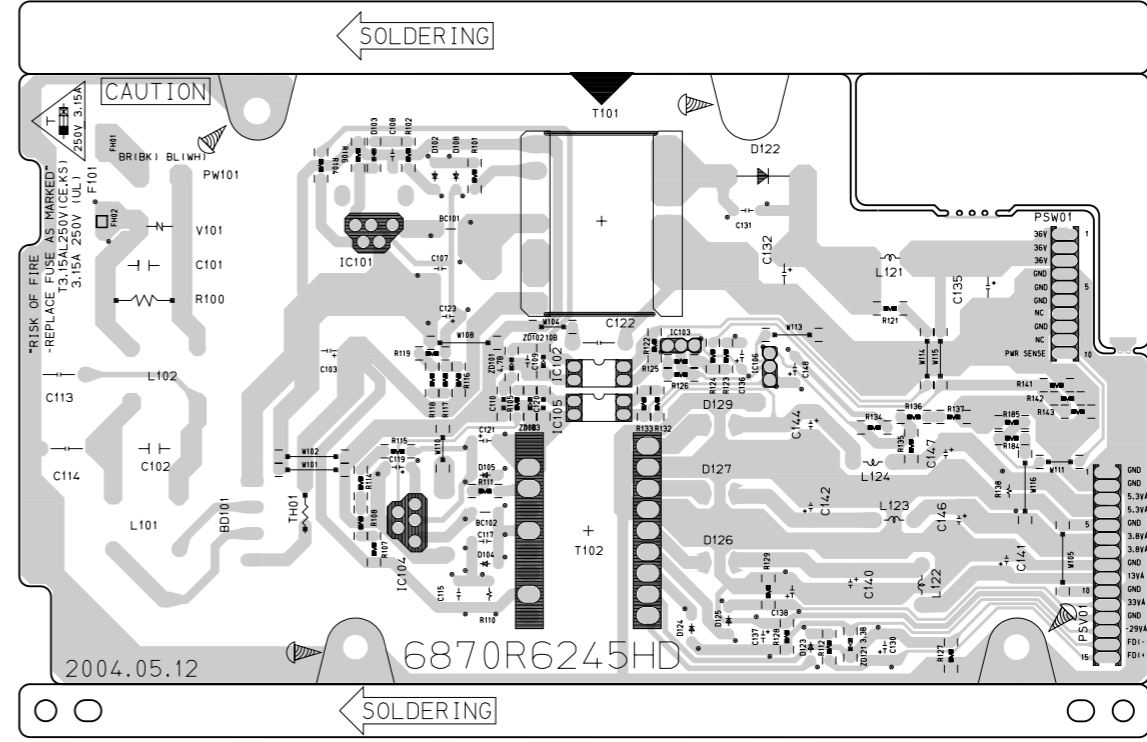

DVD PART

ELECTRICAL TROUBLESHOOTING GUIDE

1. System operation flow

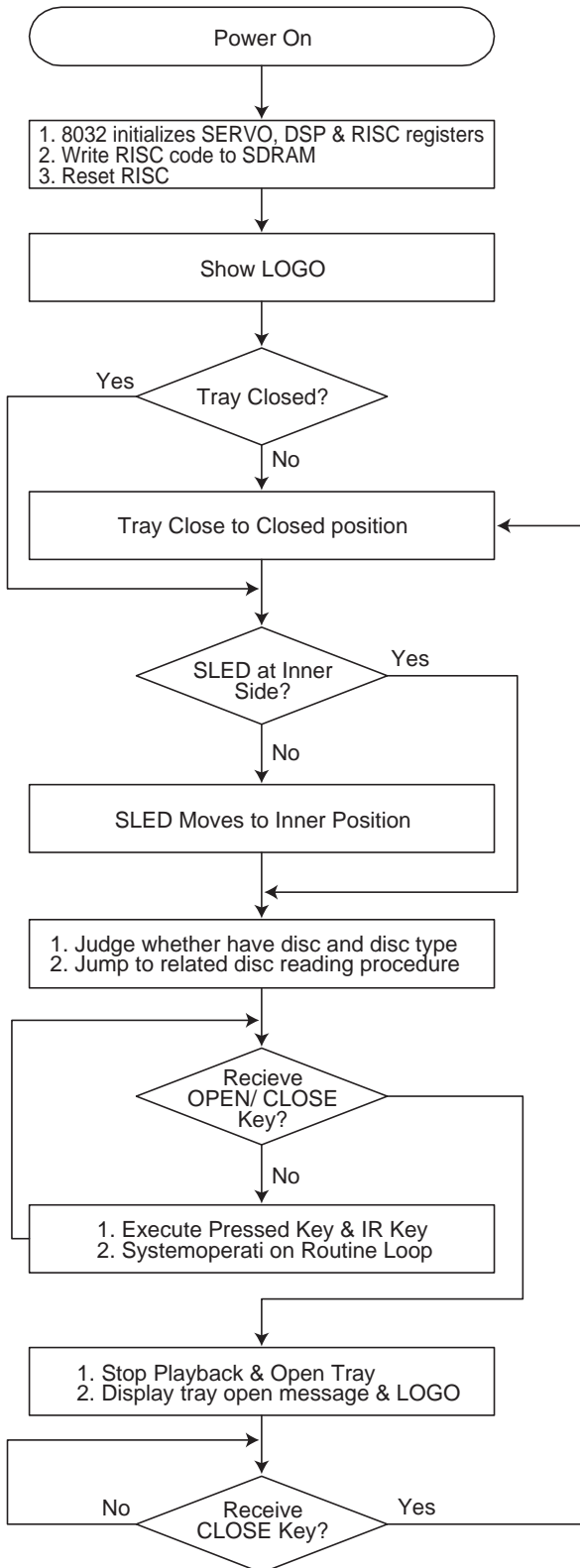

2. SYSTEM Test flow

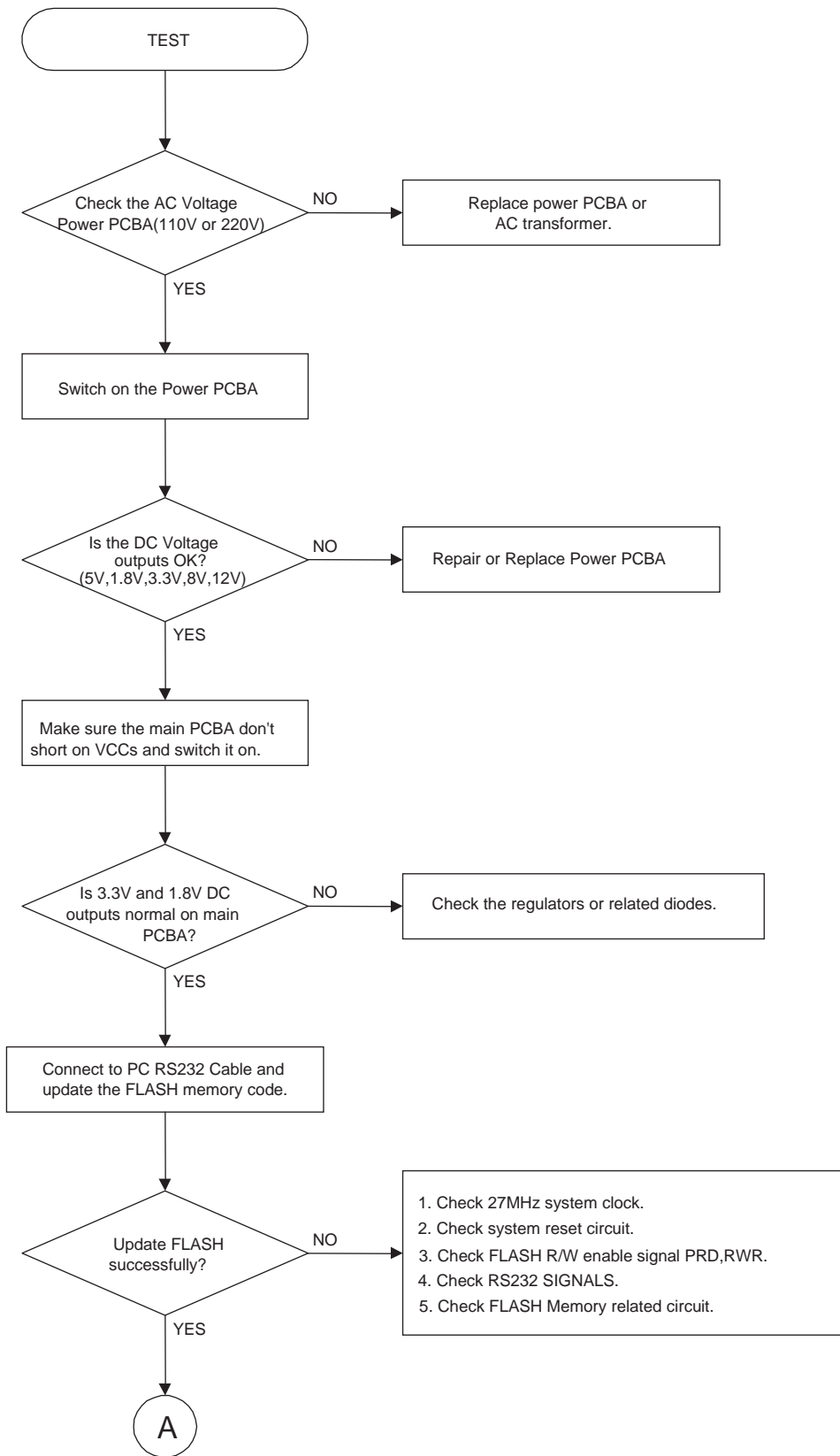

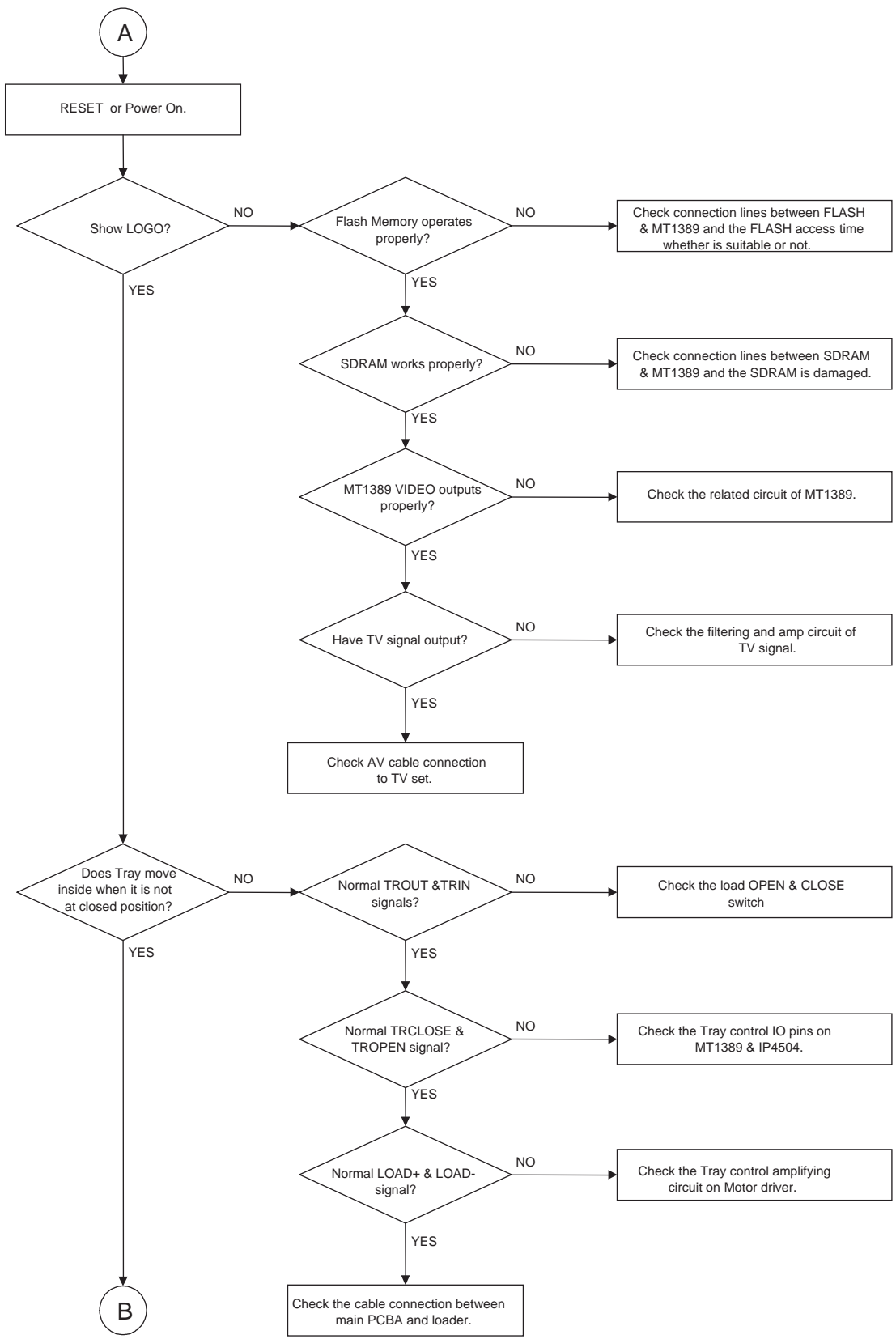

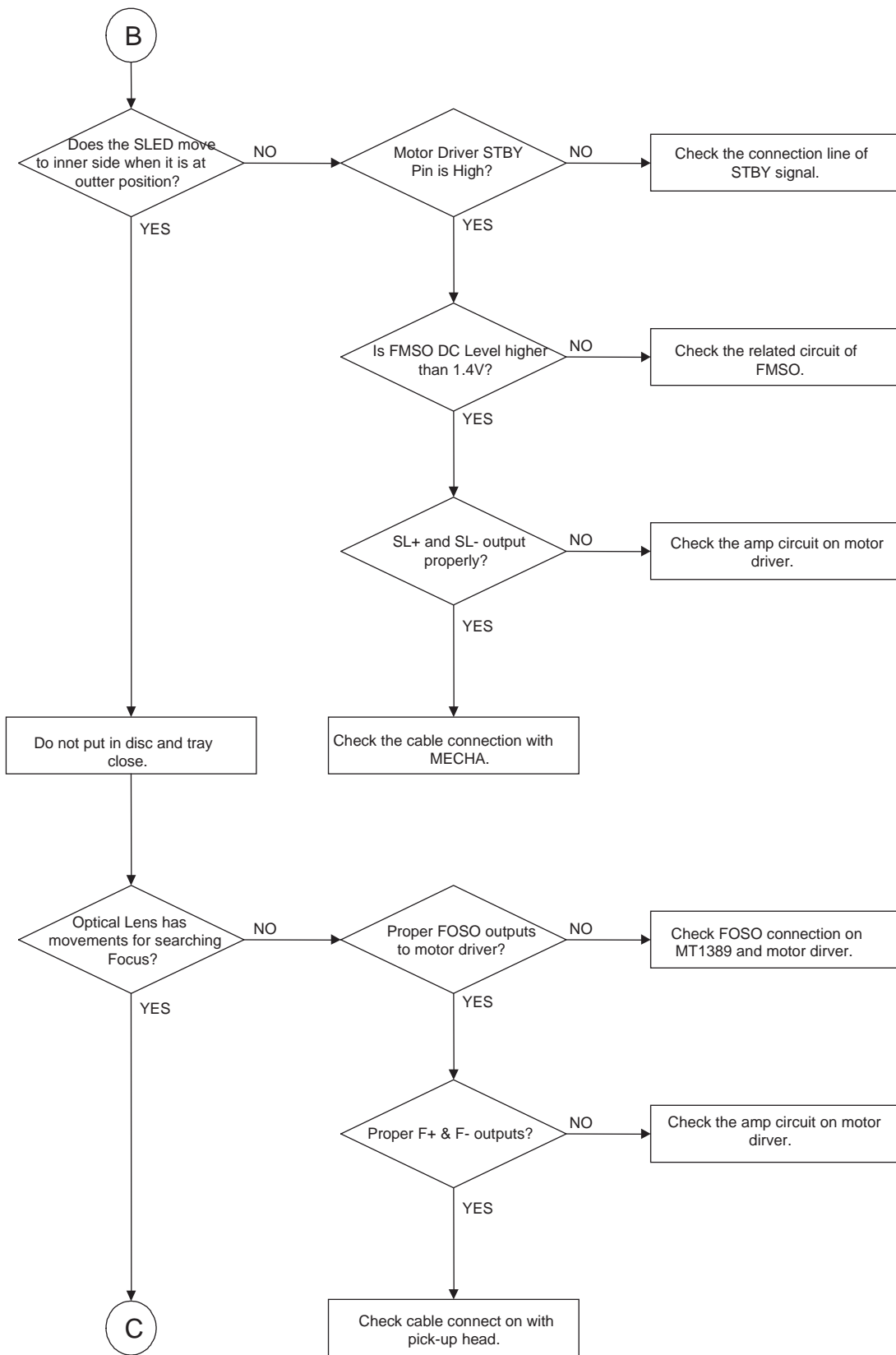

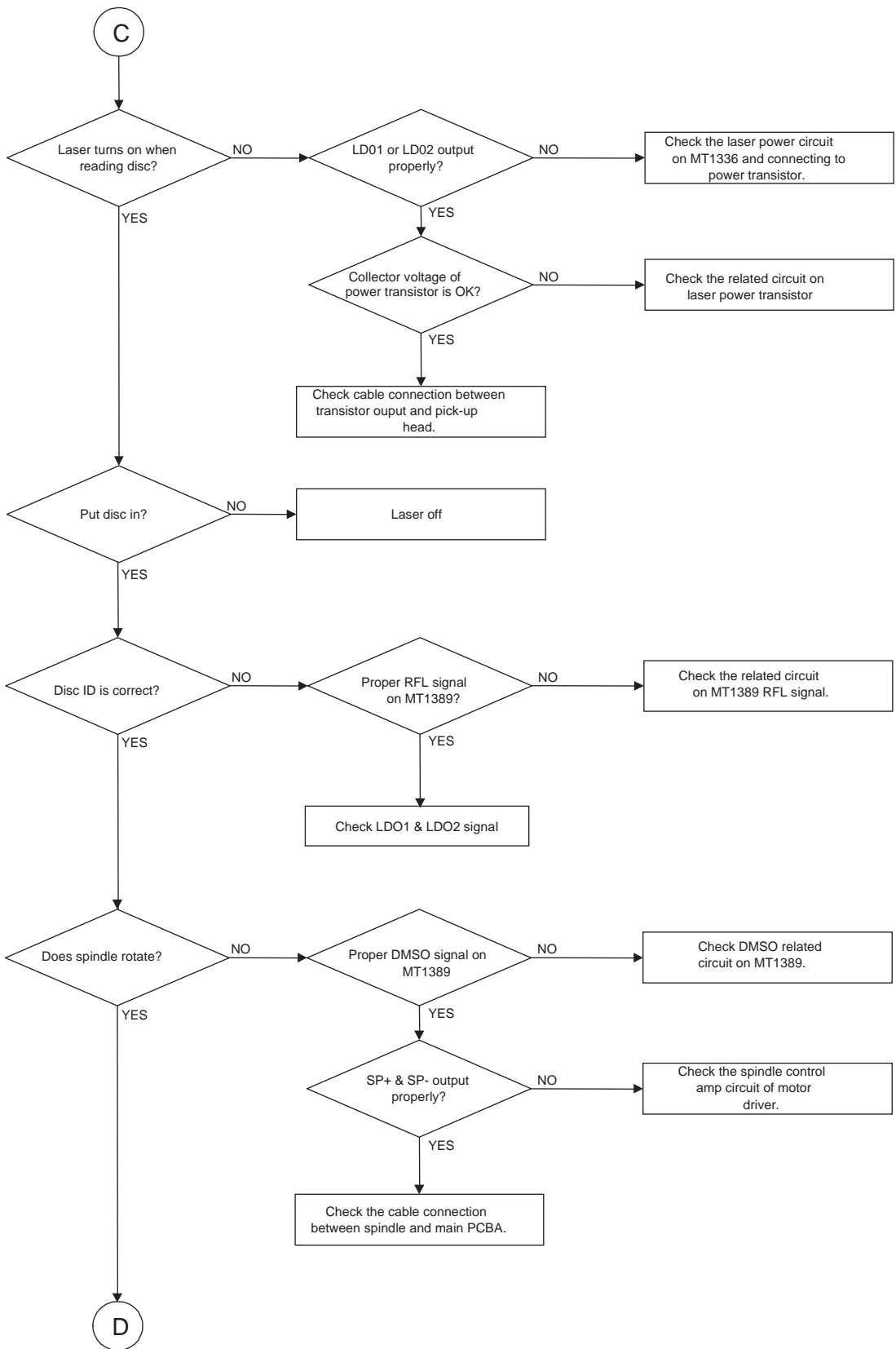

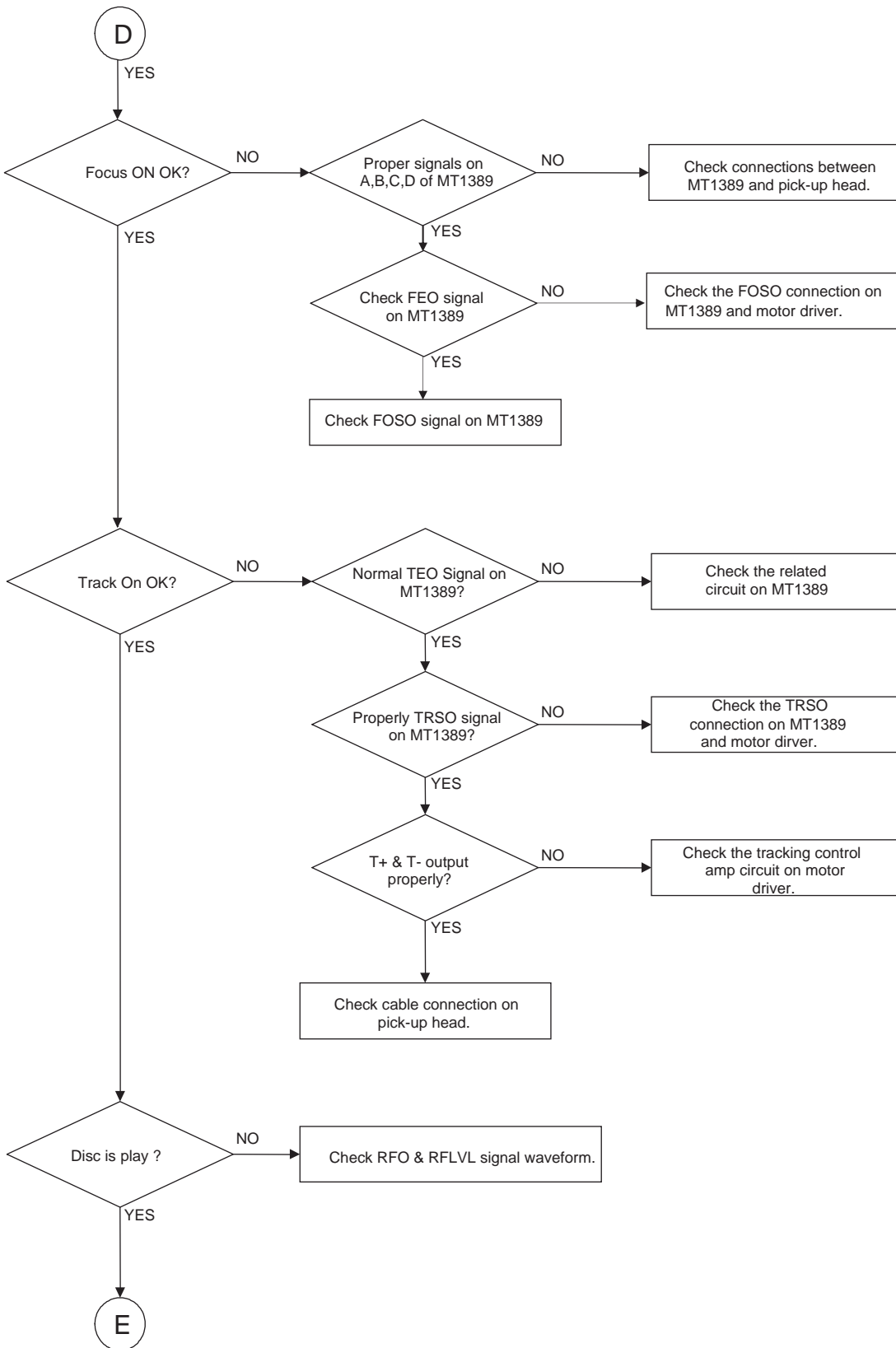

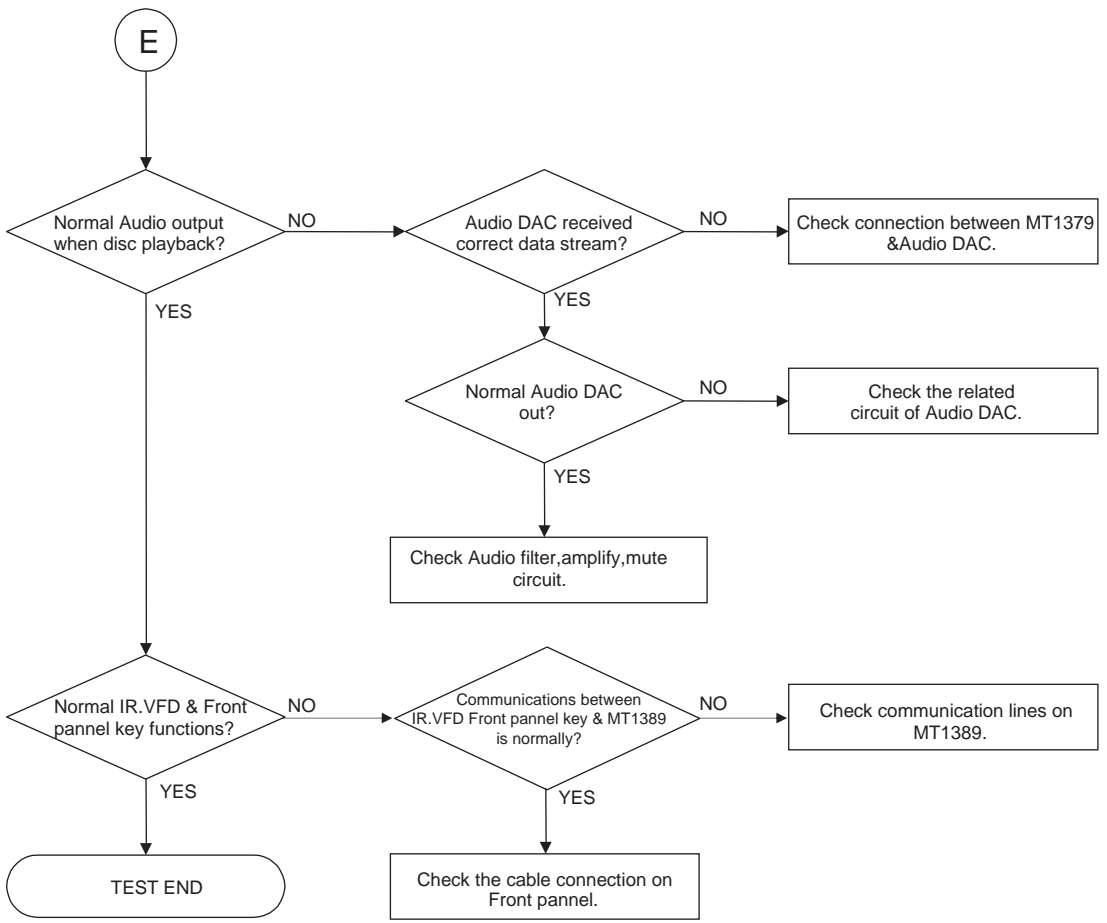

DETAILS AND WAVEFORMS ON SYSTEM TEST AND DEBUGGING

1. SYSTEM 27MHz CLOCK, RESET, FLASH R/W SIGNAL

1) MT1389 main clock is at 27MHz(X501)

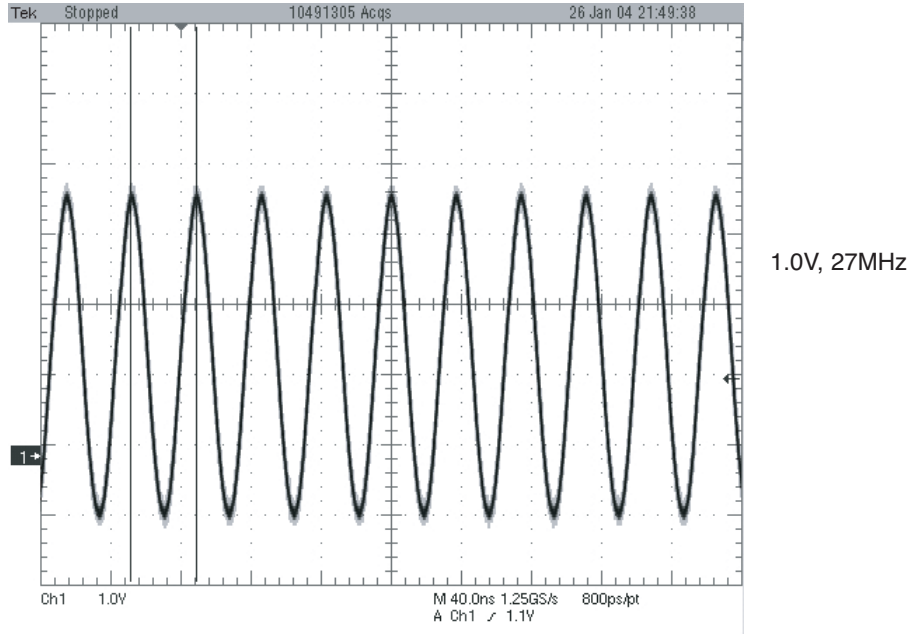

FIG 1-1

2) MT1389 reset is low active

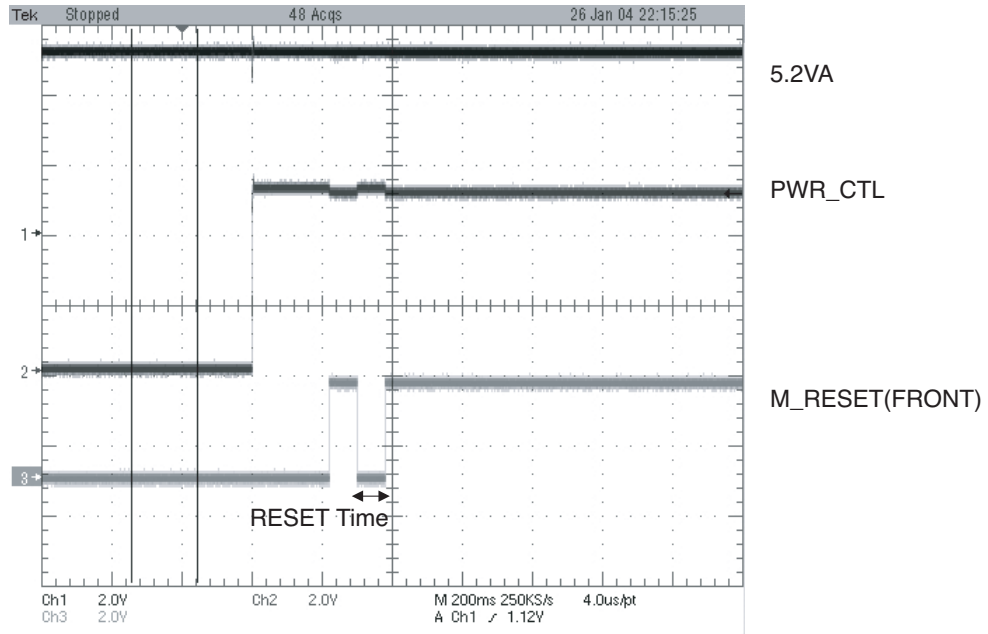

FIG 1-2

3) RS232 waveform during procedure(Downloading)

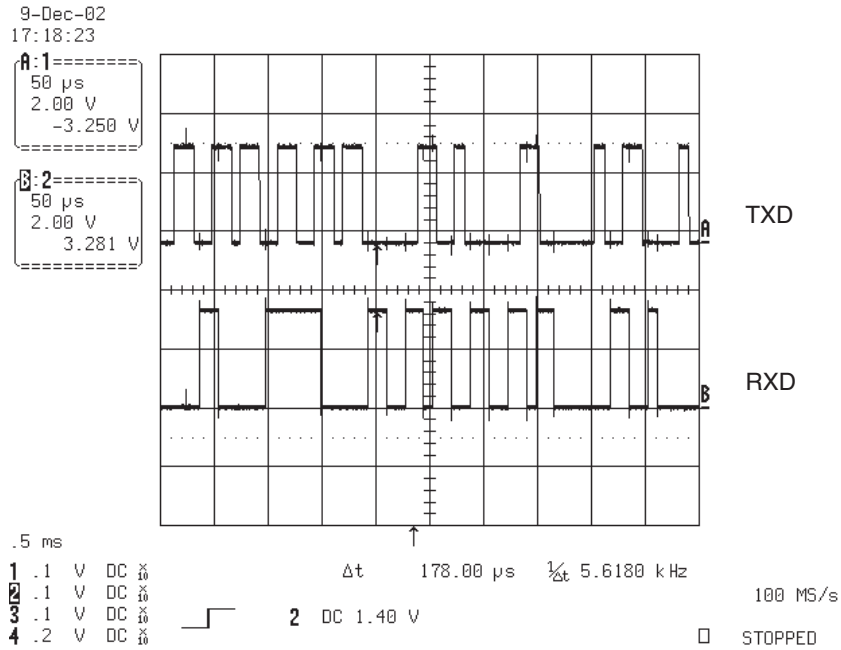

FIG 1-3

4) Flash R/W enable signal during download(Downloading)

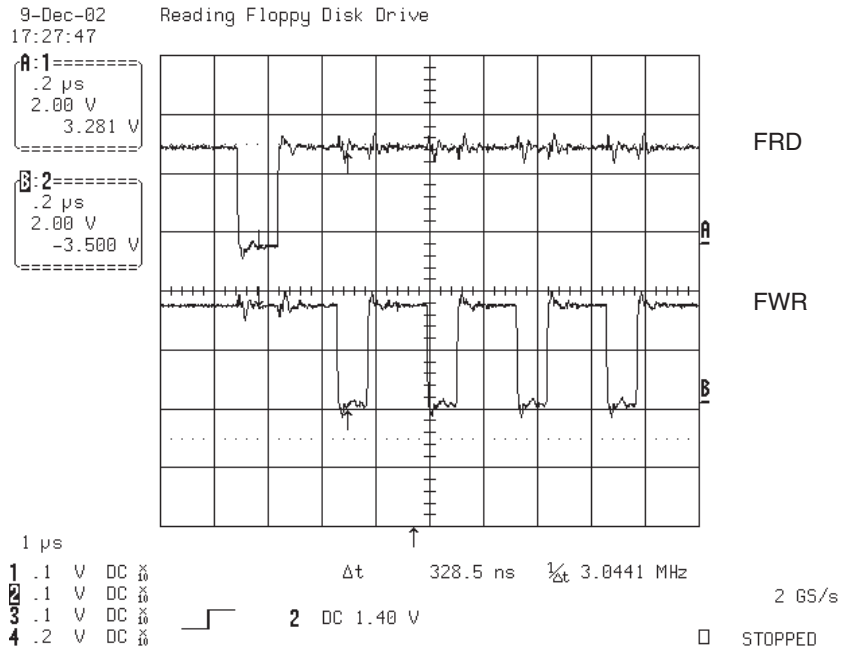

FIG 1-4

2. SDRAM CLOCK

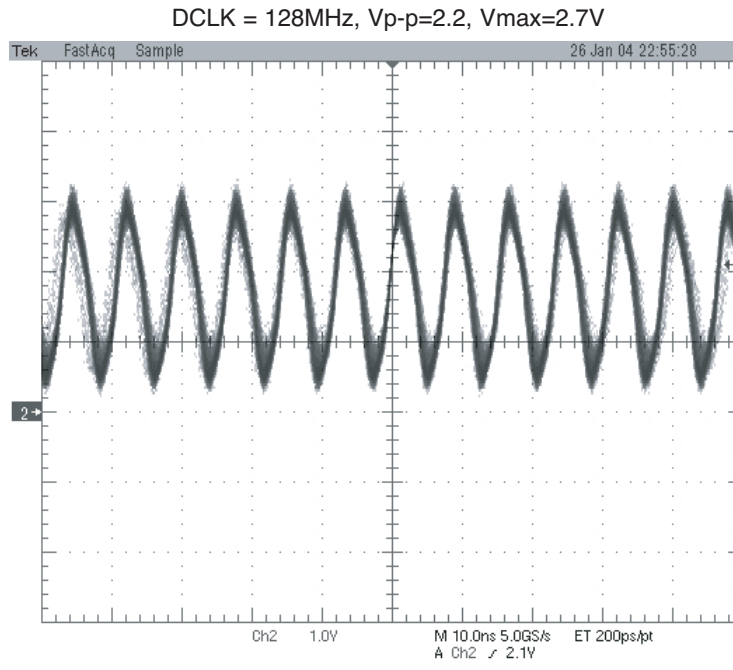

FIG 2-1

3. TRAY OPEN/CLOSE SIGNAL

1) Tray open/close waveform

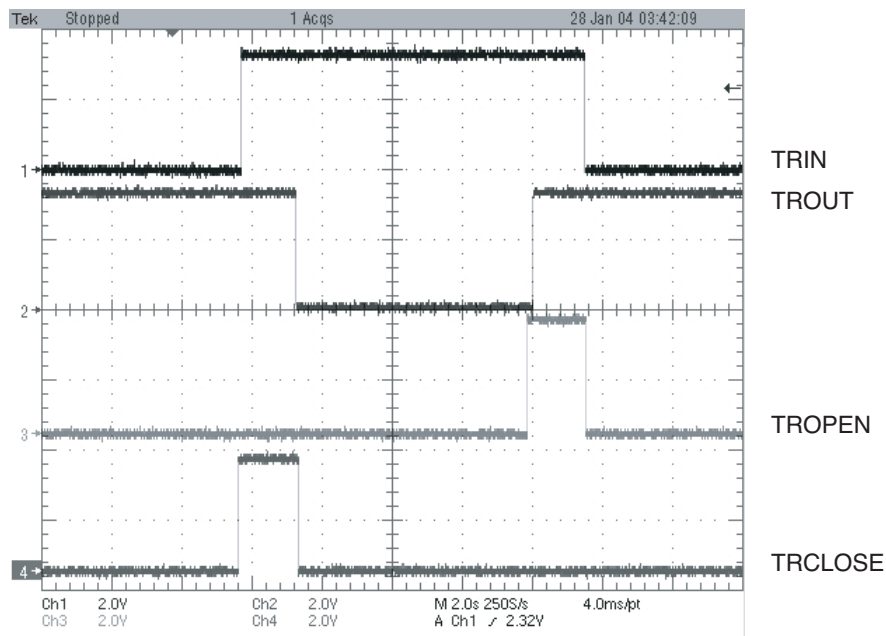

FIG 3-1

4. SLED CONTROL RELATED SIGNAL (NO DISC CONDITION)

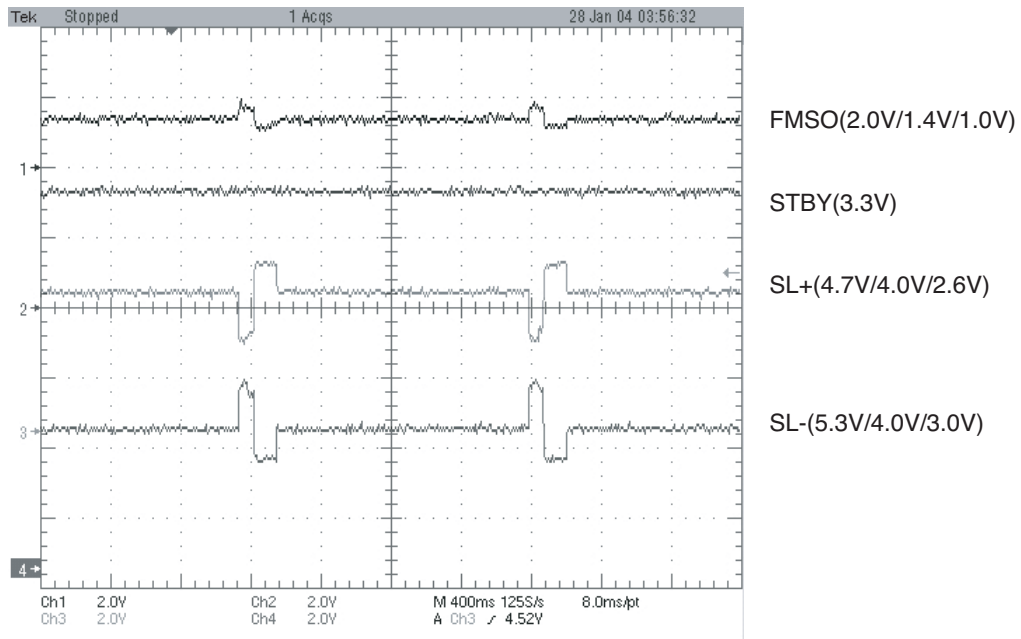

FIG 4-1

5. LENS CONTROL RELATED SIGNAL(NO DISC CONDITION)

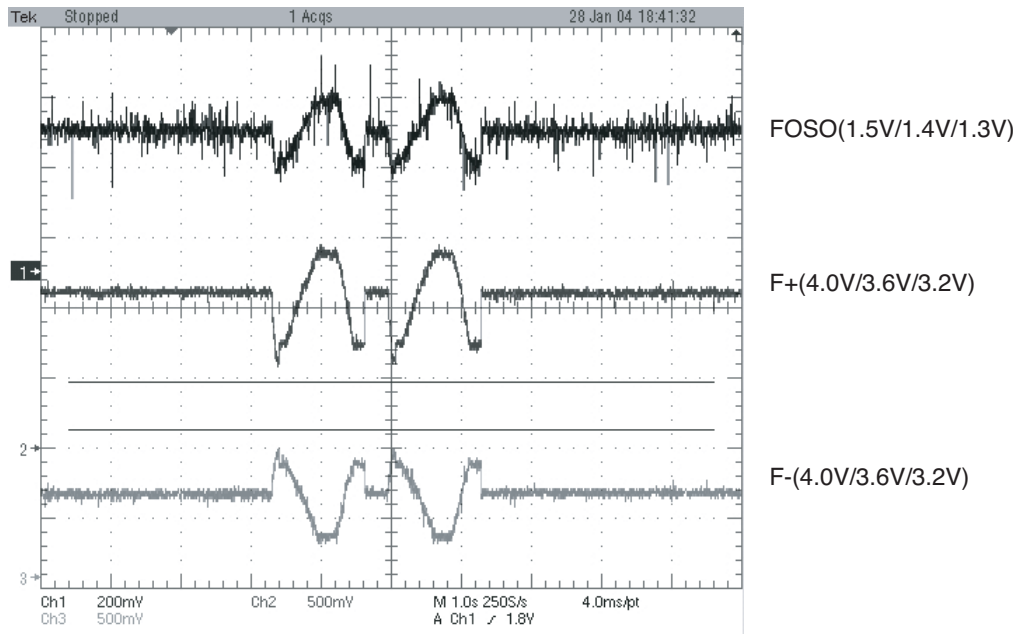

FIG 5-1

6. LASER POWER CONTROL RELATED SIGNAL(NO DISC CONDITION)

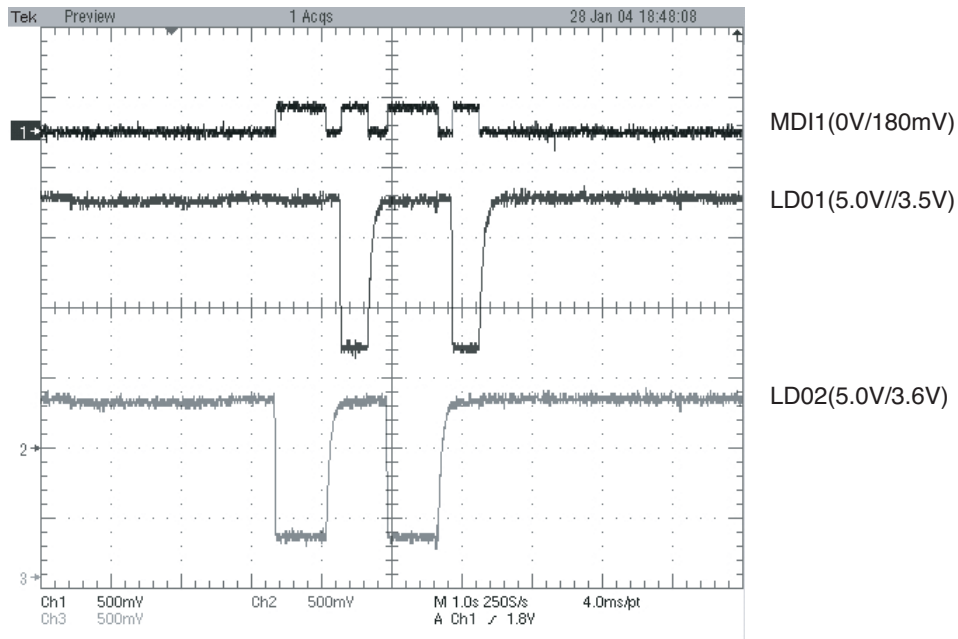

FIG 6-1

7. DISC TYPE JUDGEMENT WAVEFORM

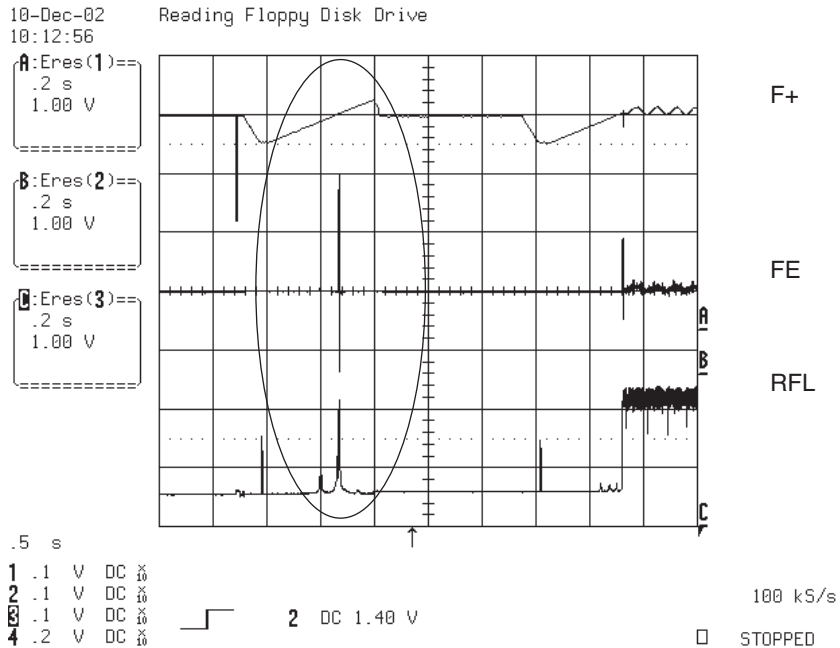

FIG 7-1 (DVD)

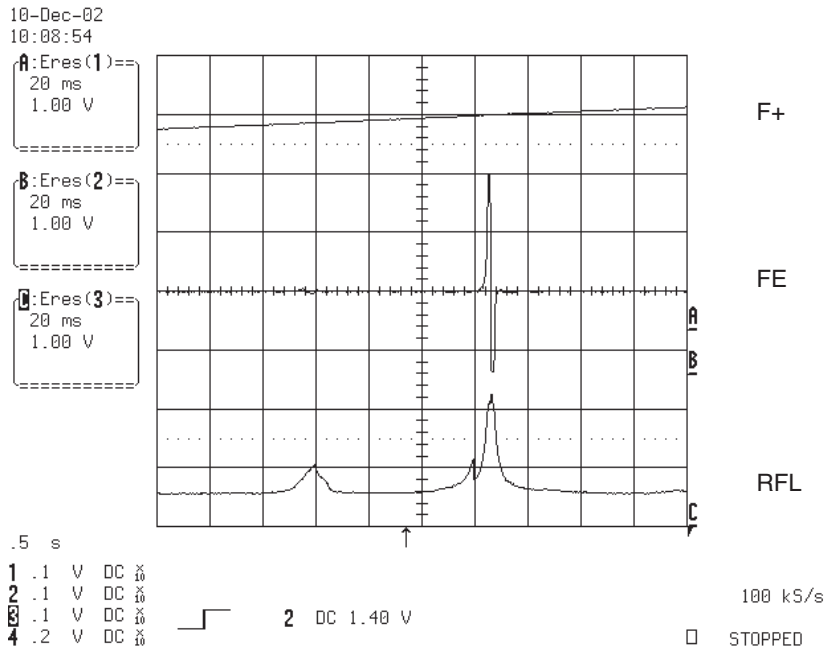

FIG 7-2 (DVD)

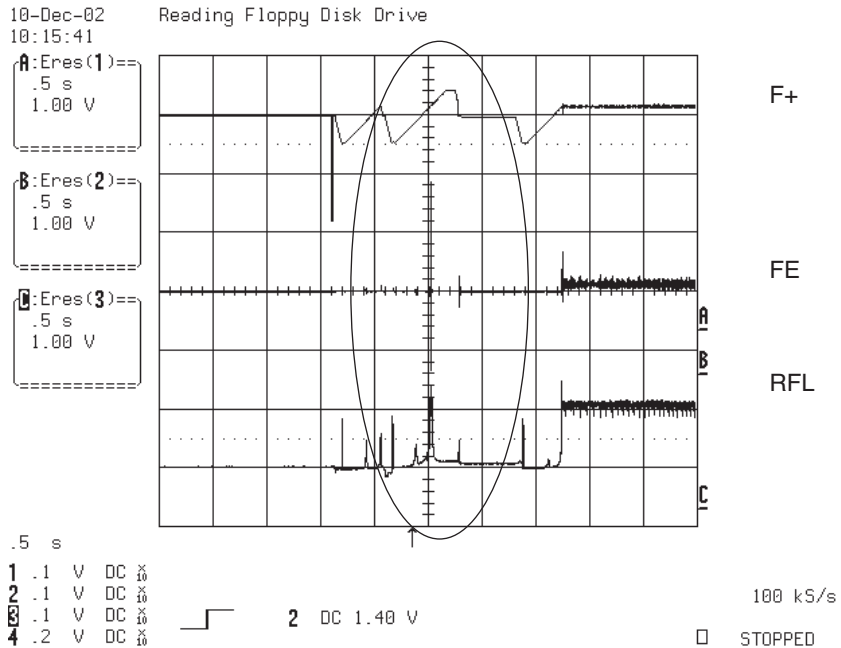

FIG 7-3 (CD)

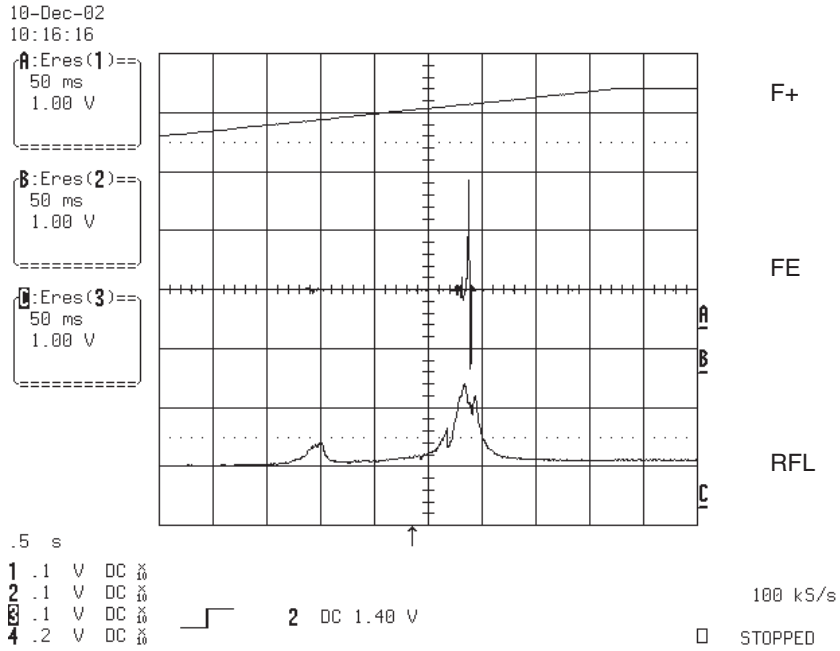

FIG 7-4 (CD)

8. FOCUS ON WAVEFORM

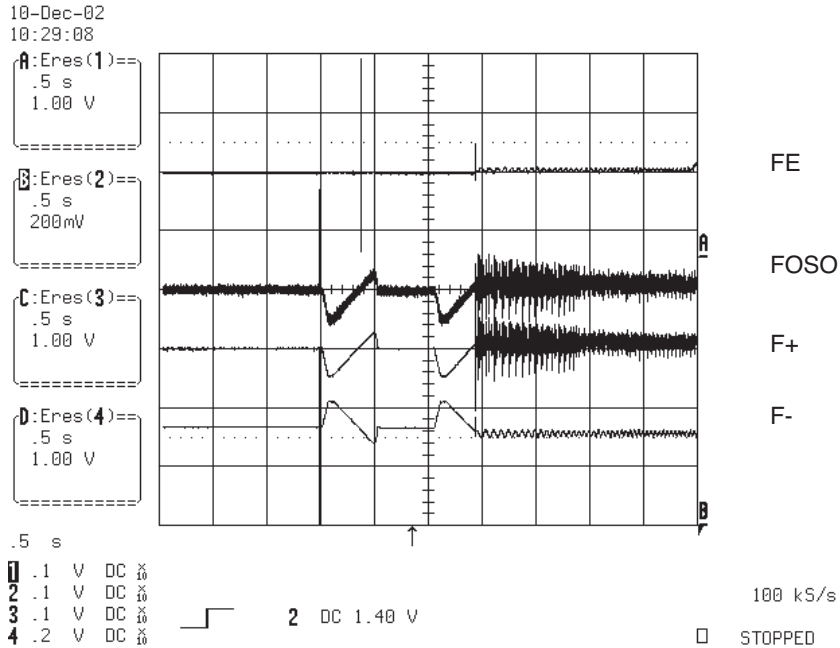

FIG 8-1 (DVD)

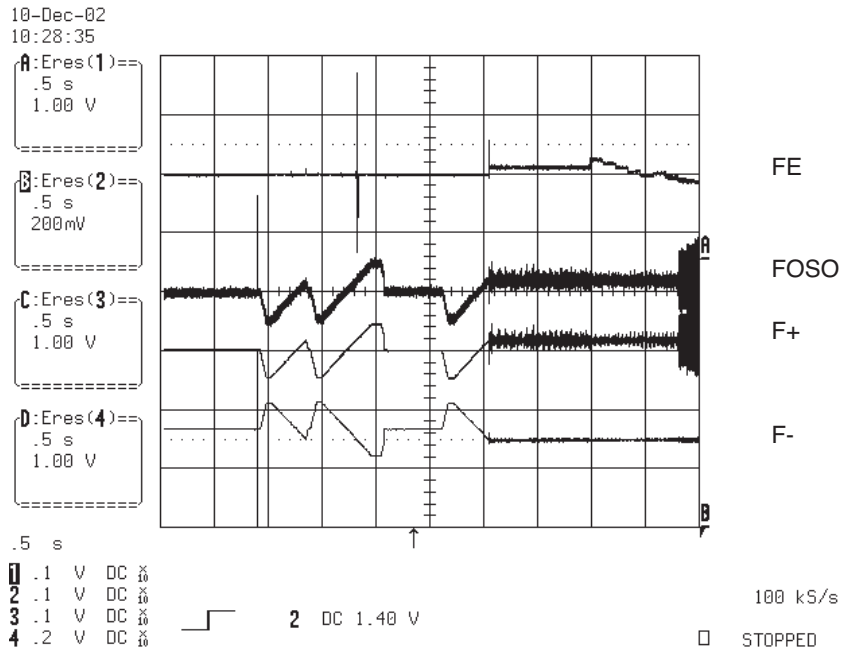

FIG 8-2 (CD)

9. SPINDLE CONTROL WAVEFORM (NO DISC CONDITION)

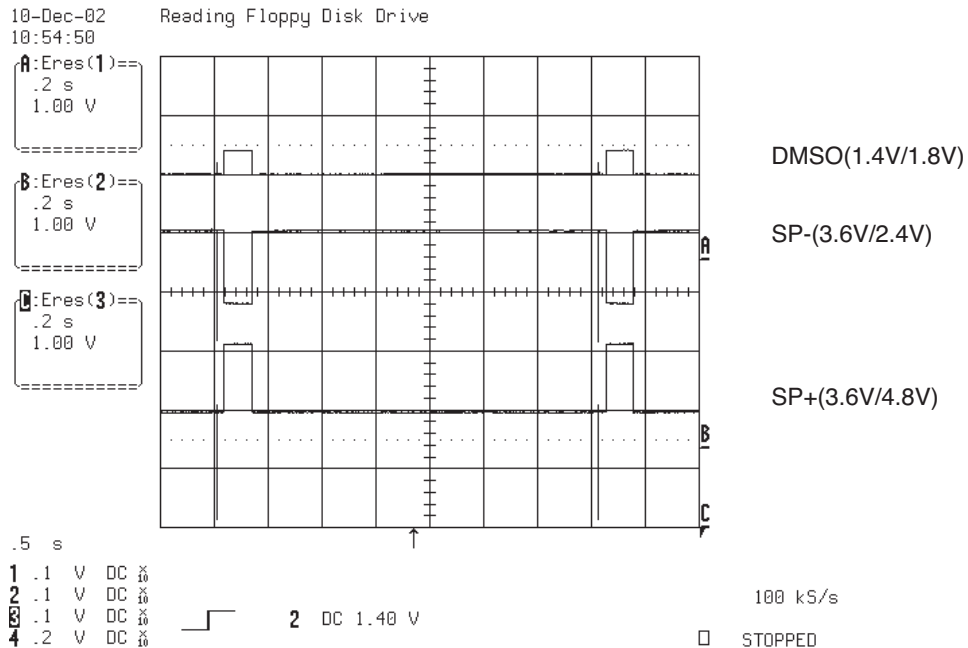

FIG 9-1

10. TRACKING CONTROL RELATED SIGNAL(System checking)

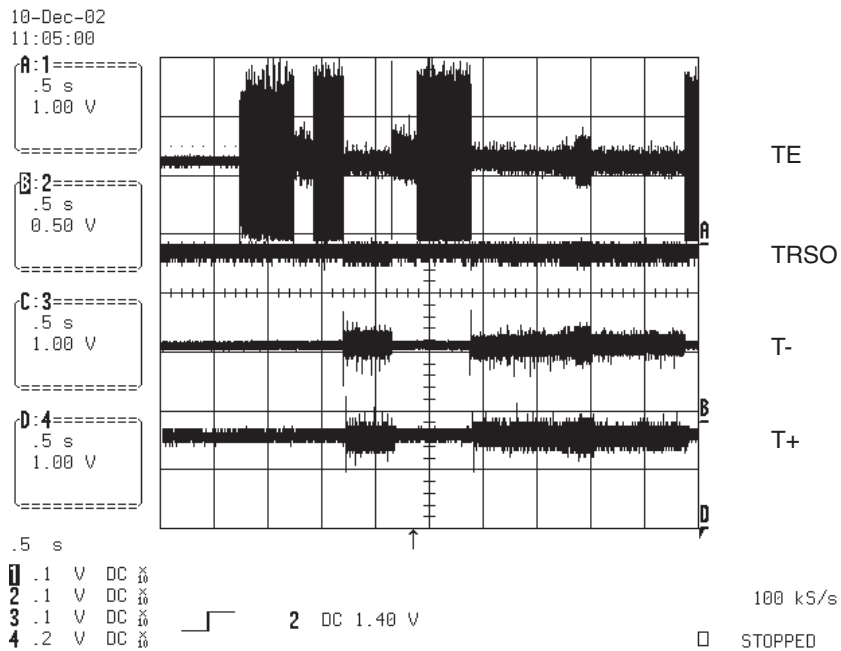

FIG 10-1(DVD)

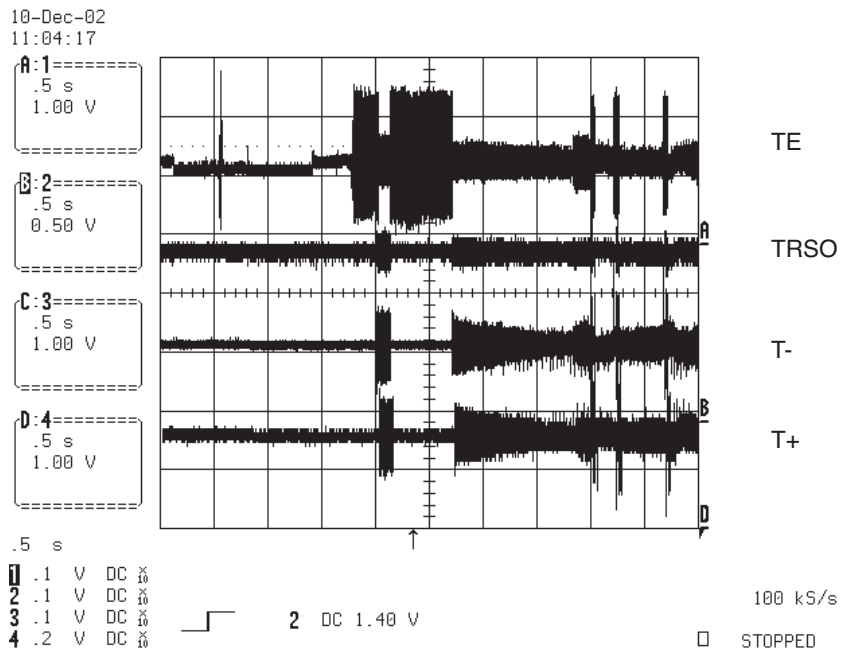

FIG 10-2(CD)

11. MT1389 AUDIO OPTICAL AND COAXIAL OUTPUT(SPDIF)

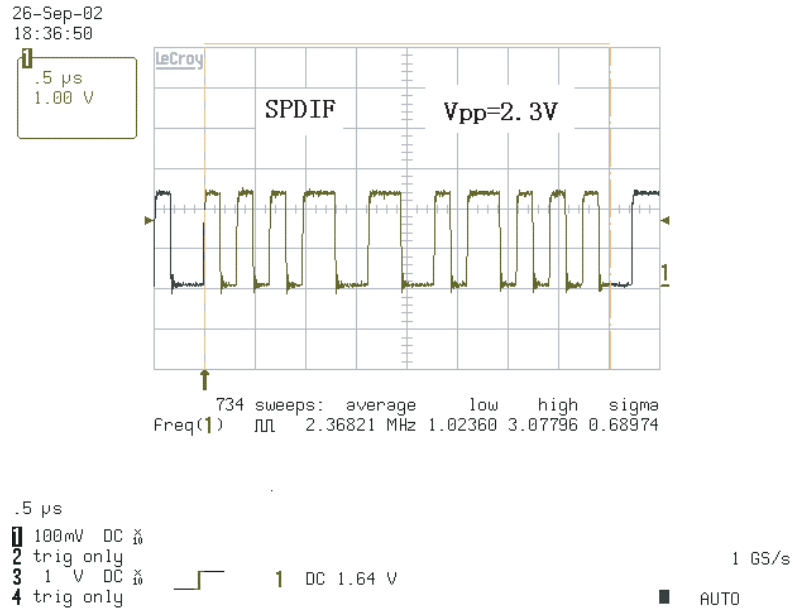

FIG 11-1

12. MT1389 VIDEO OUTPUT WAVEFORM

1) 100%

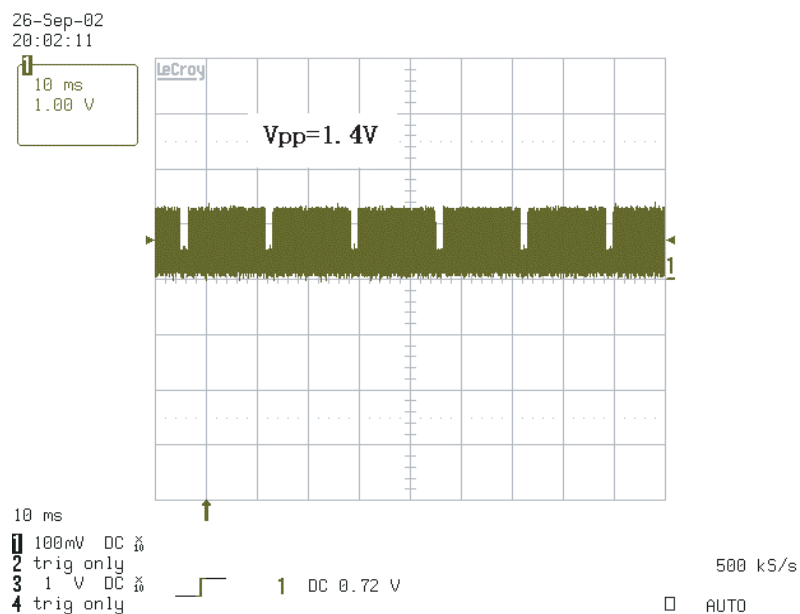

FIG 12-1

2) COMPOSITE VIDEO SIGNAL

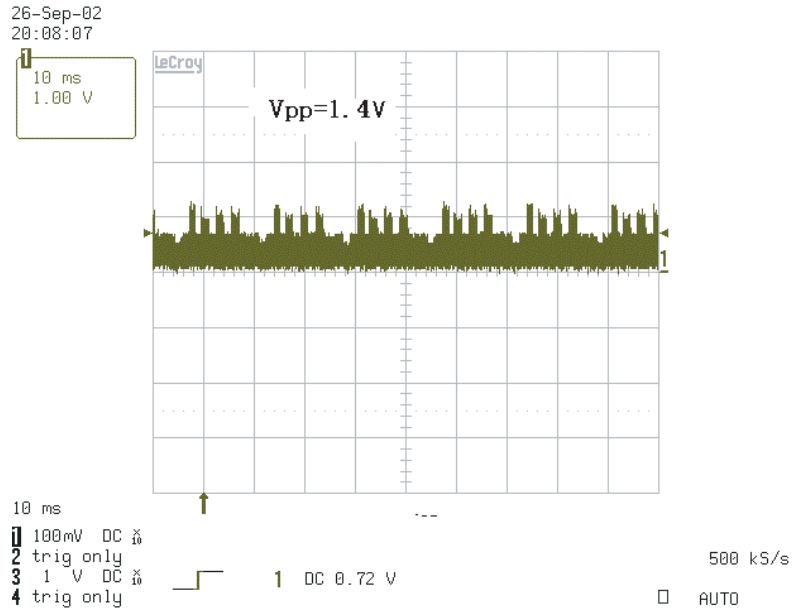

FIG 12-2

13. MT1389 AUDIO OUTPUT TO AUDIO DAC

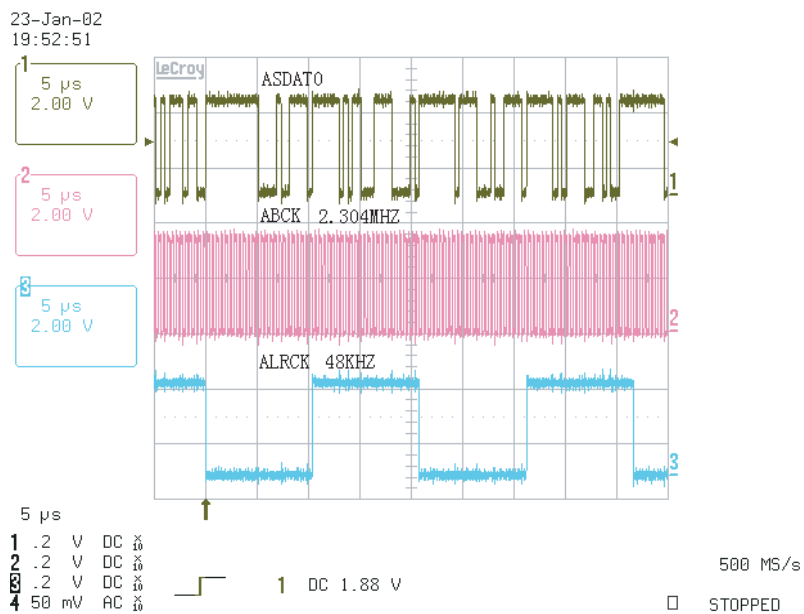

FIG 13-1

14. AUDIO OUTPUT FROM AUDIO DAC

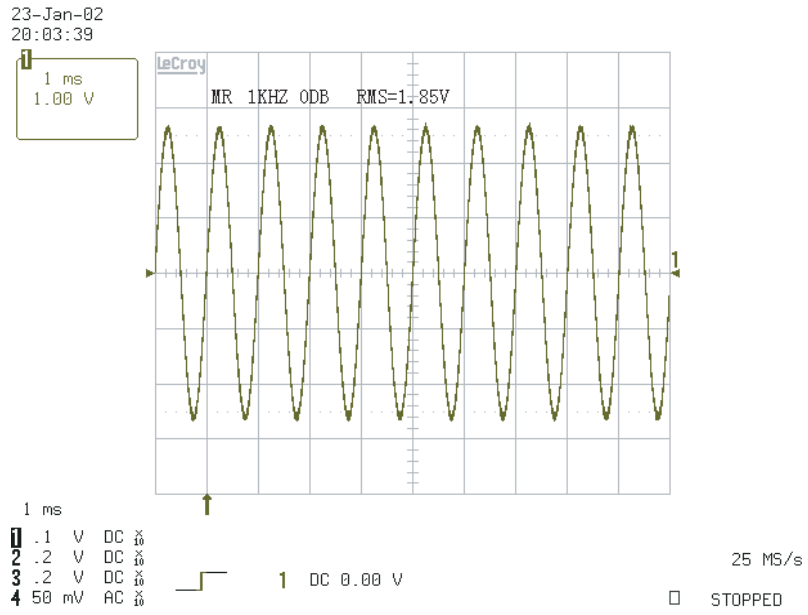
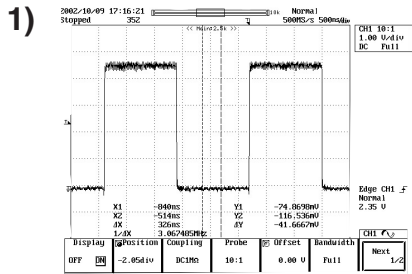
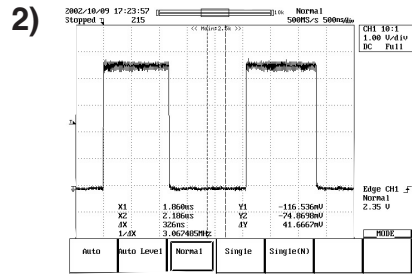

FIG 14-1

15. DVD & AMP WAVEFORMS



• R311 → FRONT L



• R303 → FRONT R

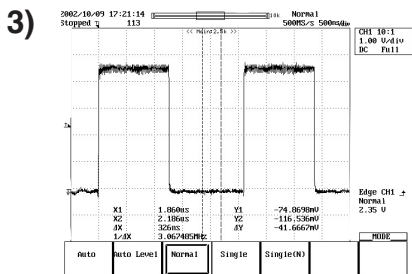

• R309 → SURROUND L

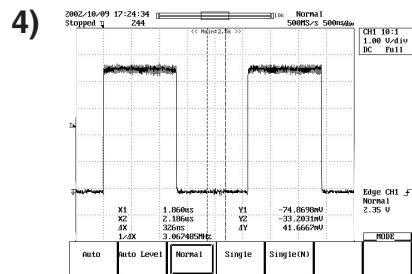

• R301 → SURROUND R

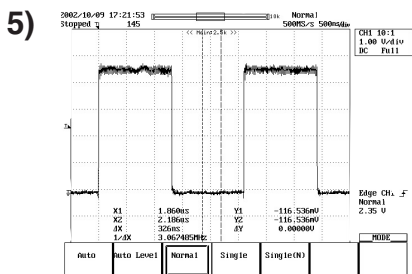

• R307 → CENTER

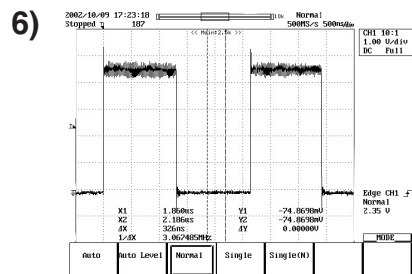

• R305 → WOOFER

BLOCK DIAGRAMS

1. Overall Block Diagram_200W

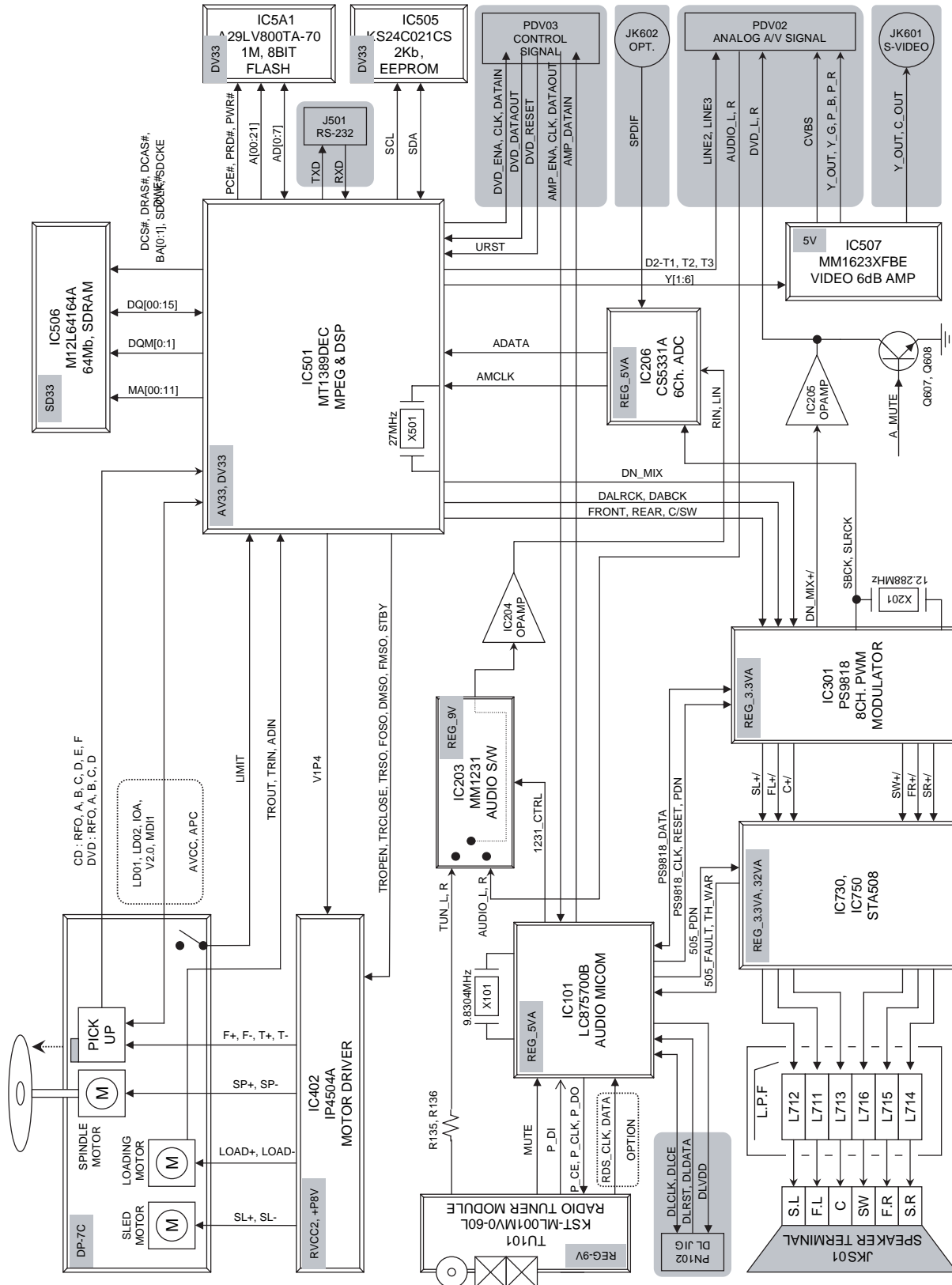

2. Overall Block Diagram_400W

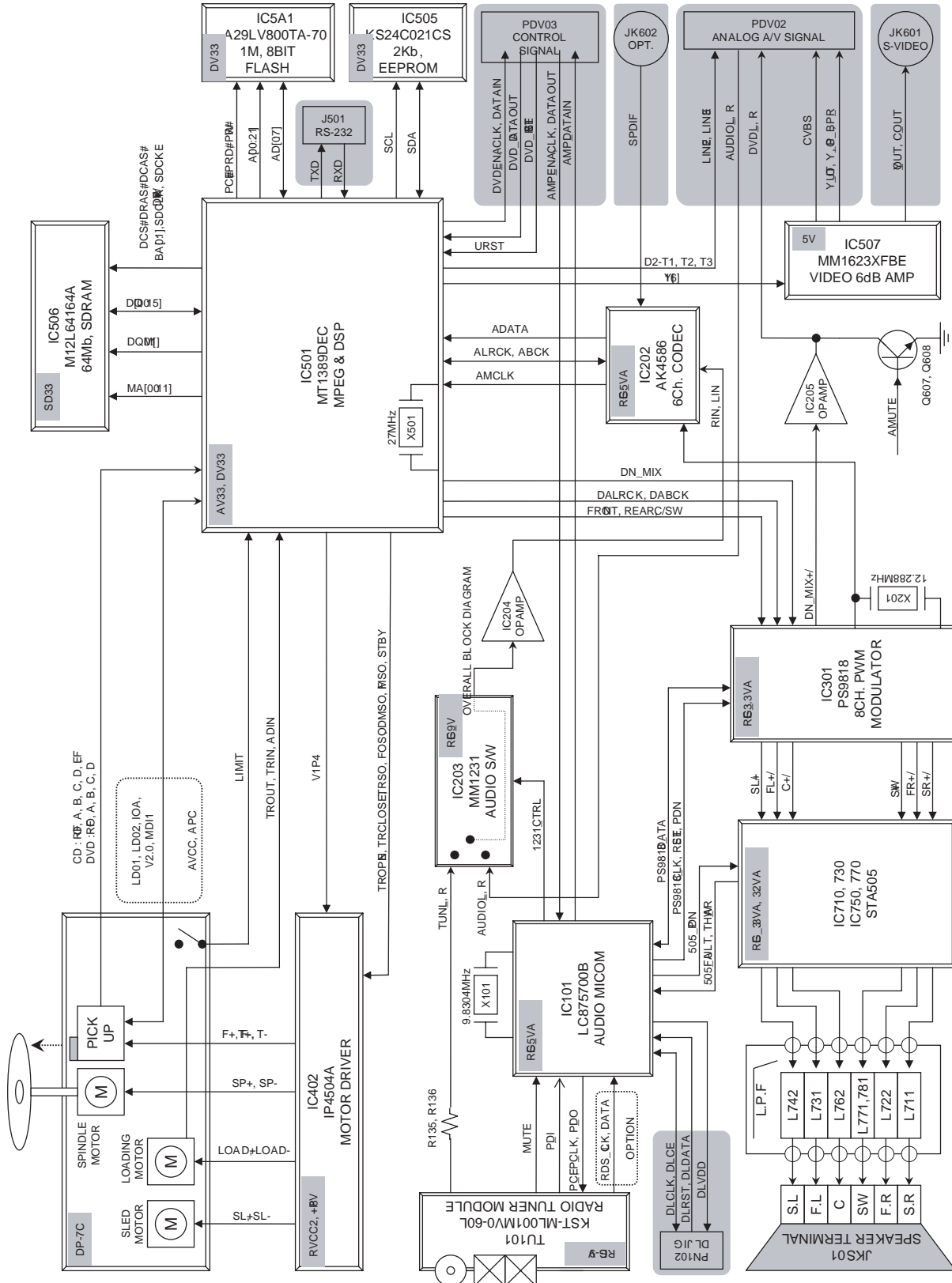

3. SERVO Block Diagram

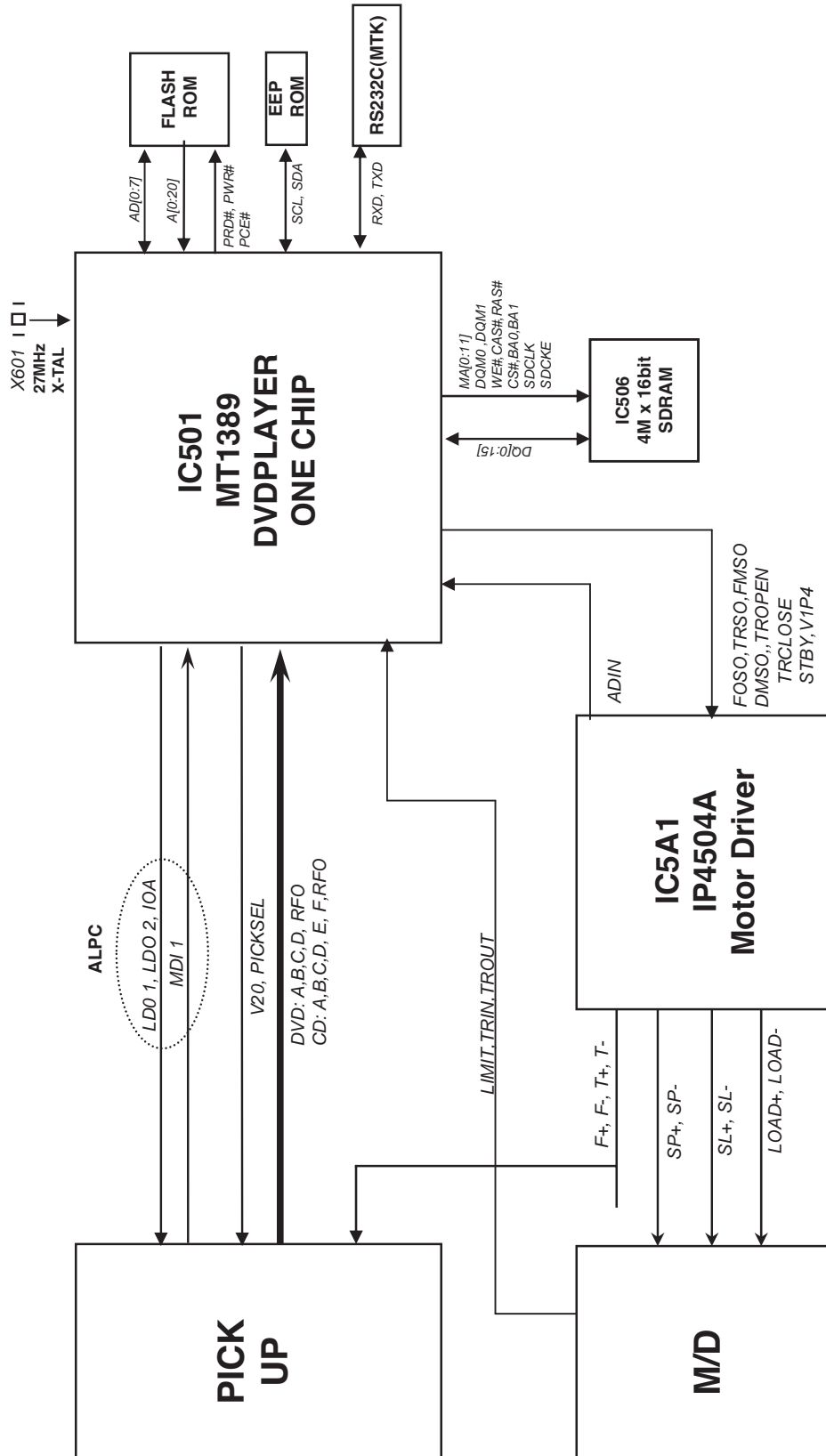

4. MPEG & MEMORY Block Diagram

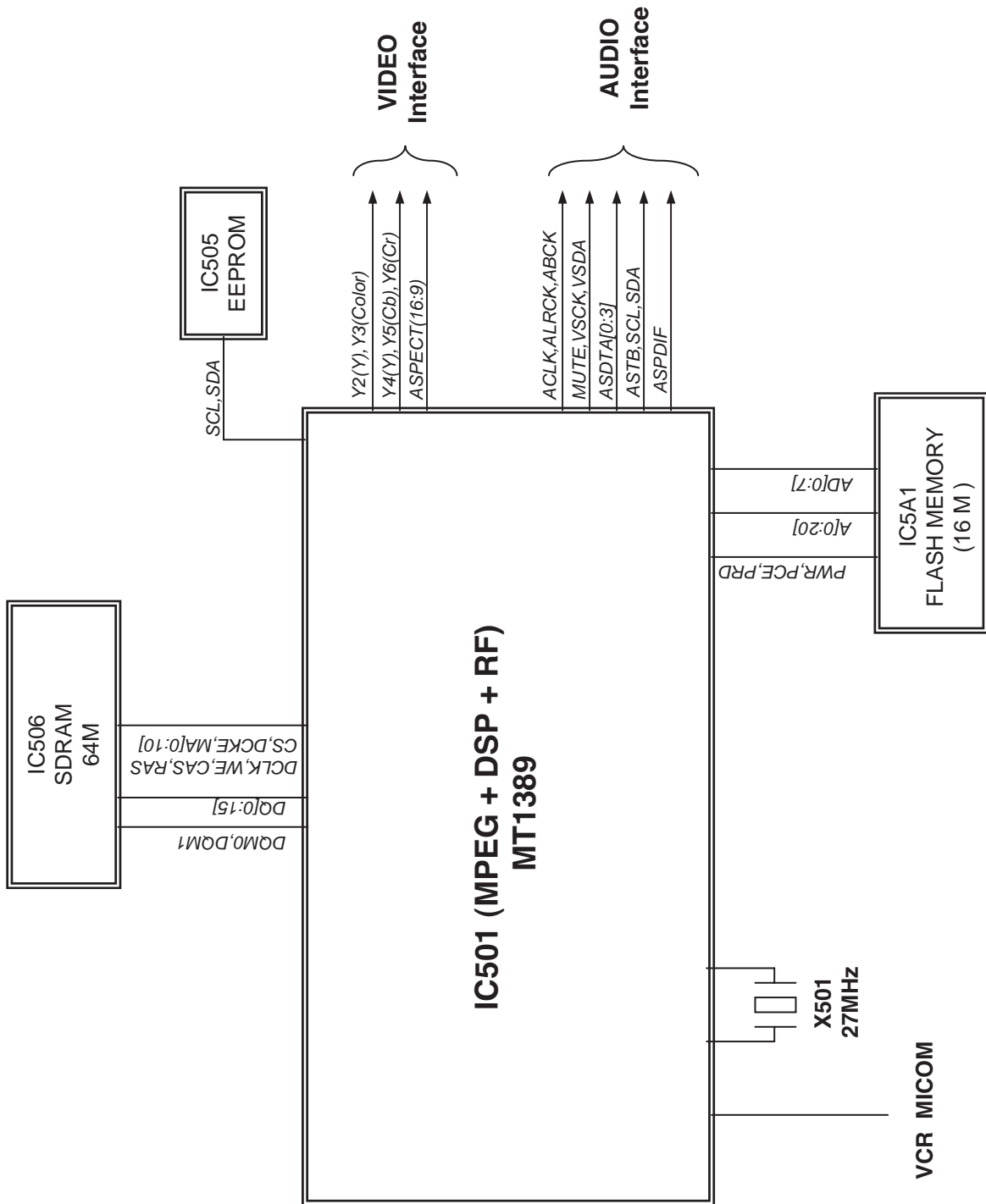

5. VIDEO & AUDIO Block Diagram

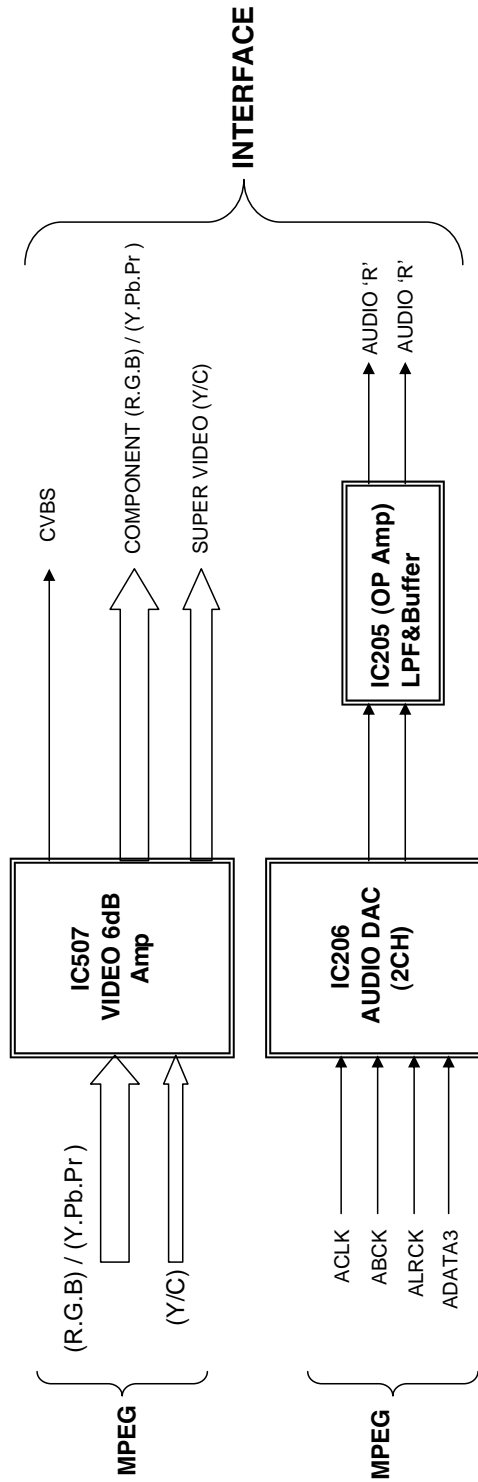

6. DVD & AMP Block Diagram

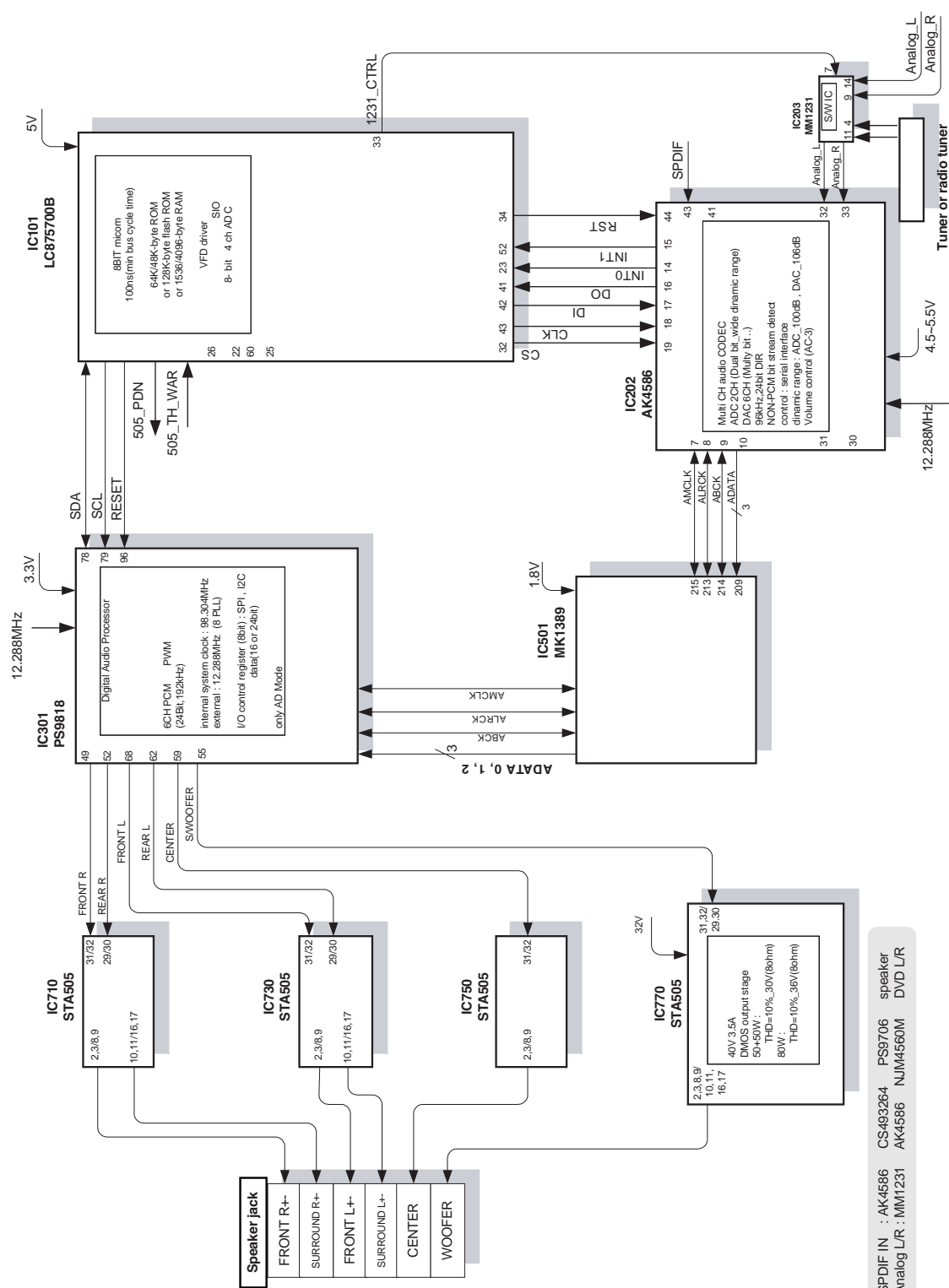

SPDIF IN : AK4586 CS493264 PS9706 speaker
 Analog L/R : MM1231 NJM4560M AK4586 DVD L/R

CIRCUIT DIAGRAMS

1. MPEG CIRCUIT DIAGRAM

12
11
10
9
8
7
6
5
4
3
2
1

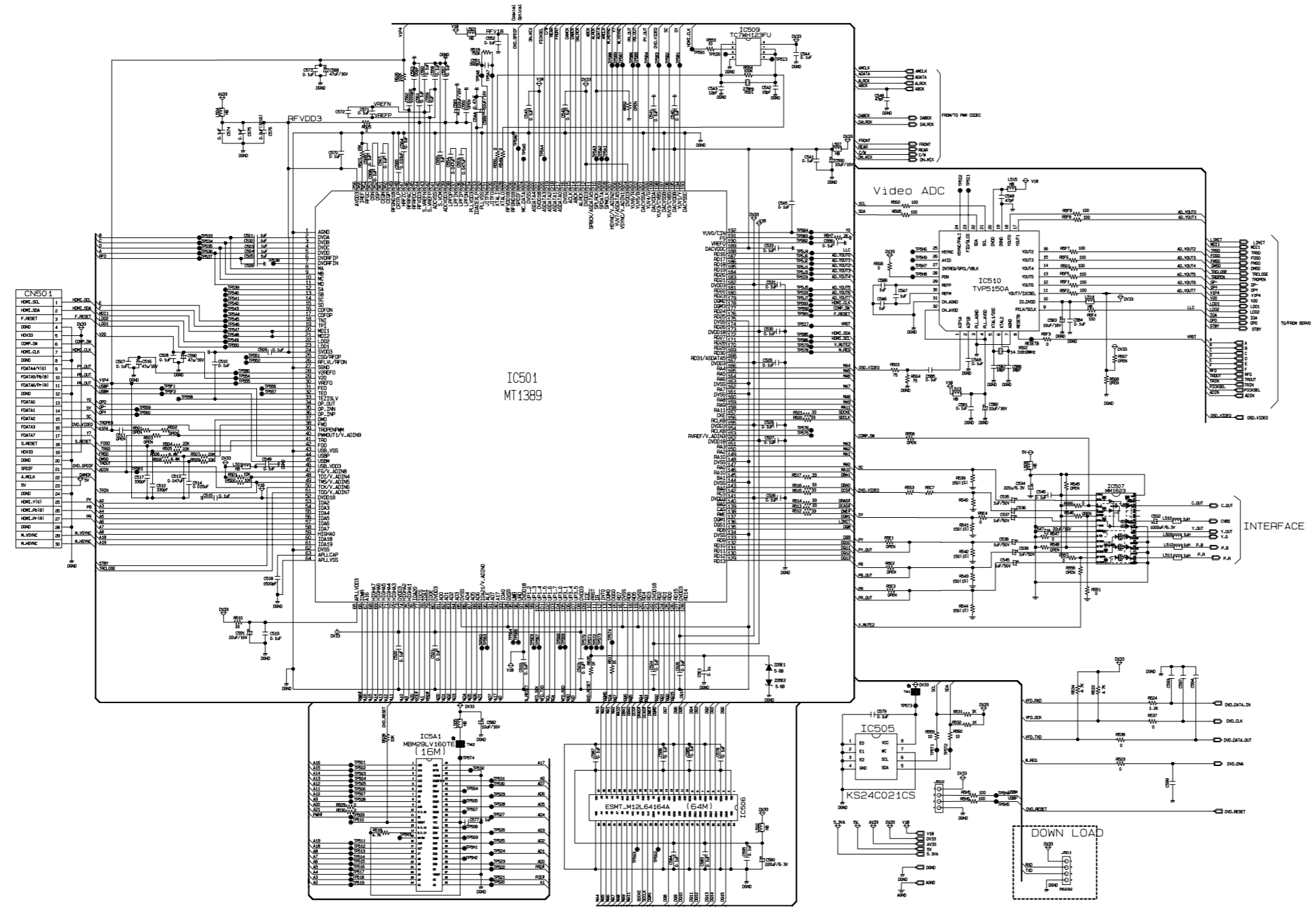

MPEG & VIDEO
XH-CW644 2004.08.16
3854R14740A

A B C D E F G H I J K L M N O P Q R S T

2. RF & SERVO CIRCUIT DIAGRAM

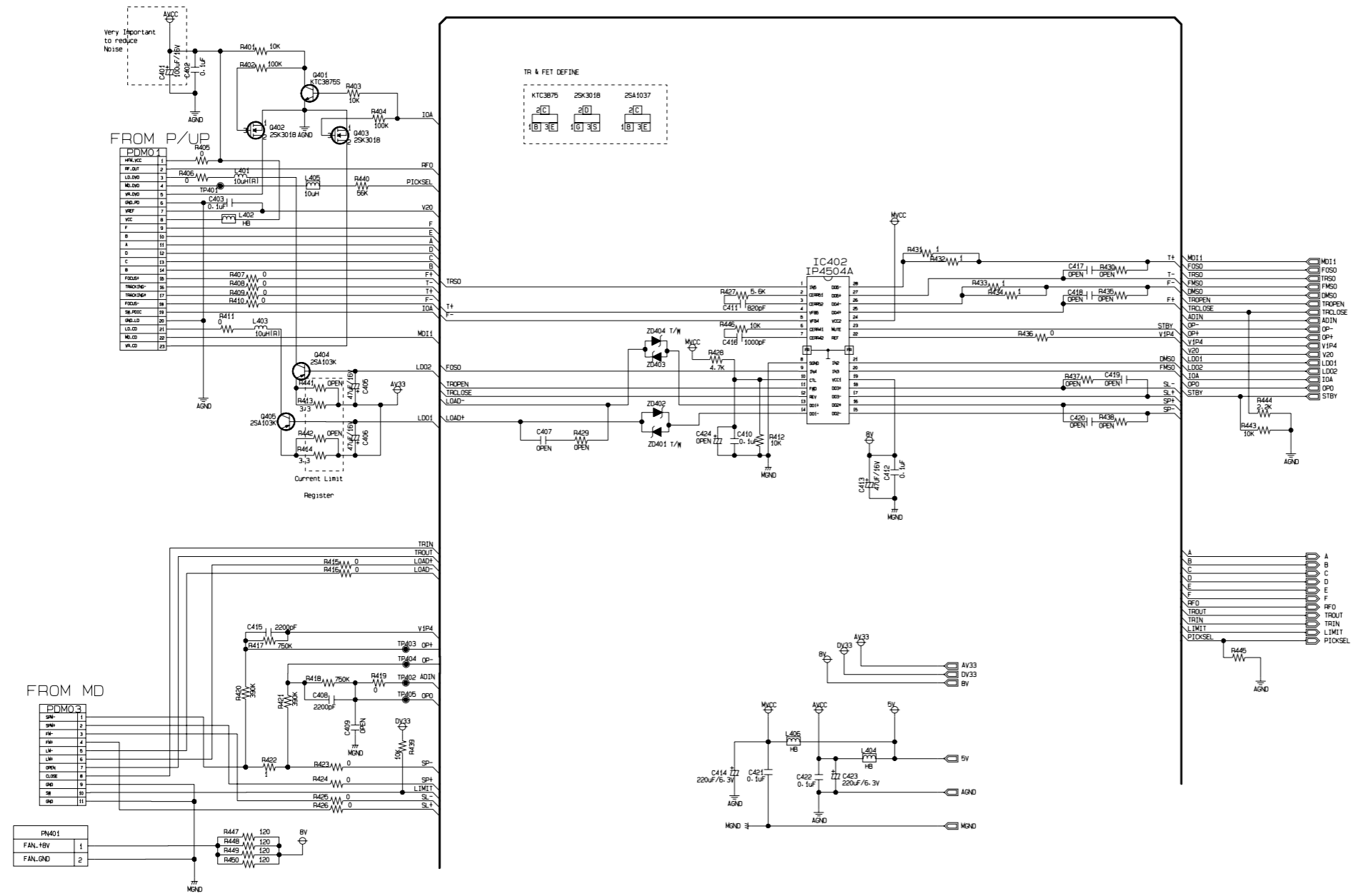

SERVO
XH-CW644 2004.08.16
3854R14741A

3. AUDIO, μ _COM CIRCUIT DIAGRAM(DVD & AMP)

* RADIO TUNER OPTION TABLE(TU101)

RDS	19KHZ FILTER	FM TUNER	AREA	BAND	FREQ. RESP.	FM MOD.	FM ANT.	KWANGSUNG PART NO.	LG PART NO.
X	X	2/3GANG/FCC	USA/S. AMERICA	FM/MW	75uS	75KHz	750hm	KST-ML000MV0-60L	6700FM0091A
X	X	2/3GANG/FCC	AUS./ASIA	FM/MW	50uS	40KHz	750hm	KST-ML000MV1-60L	6700FM0092A
X	X	3GANG/GOST	RUS./CIS(AX)	FM/MW	50uS	40KHz	750hm	KST-ML002MV1-60L	6700FM0094A
X	X	4GANG	TURKEY(AD)	FM/MW/LW	50uS	75KHz	750hm	KST-ML004MV1-60L	6700FM0095A
0	X	4GANG/CE	EU(AD)	FM/MW	50uS	40KHz	750hm	KST-ML104MV1-60L	6700FM0096A
X	X	3GANG	JAPAN(AX)	FM/MW	75uS	40KHz	750hm	KST-ML005MV0-61L	6700FM0097A
X	X	4GANG	CANARY(AD)	FM/MW	50uS	75KHz	750hm	KST-ML004MV1-60L	6700FM0098A
X	X	4GANG	KOREA(AX)	FM/MW	75uS	75KHz	750hm	KST-ML004MV0-61L	6700FM0099A

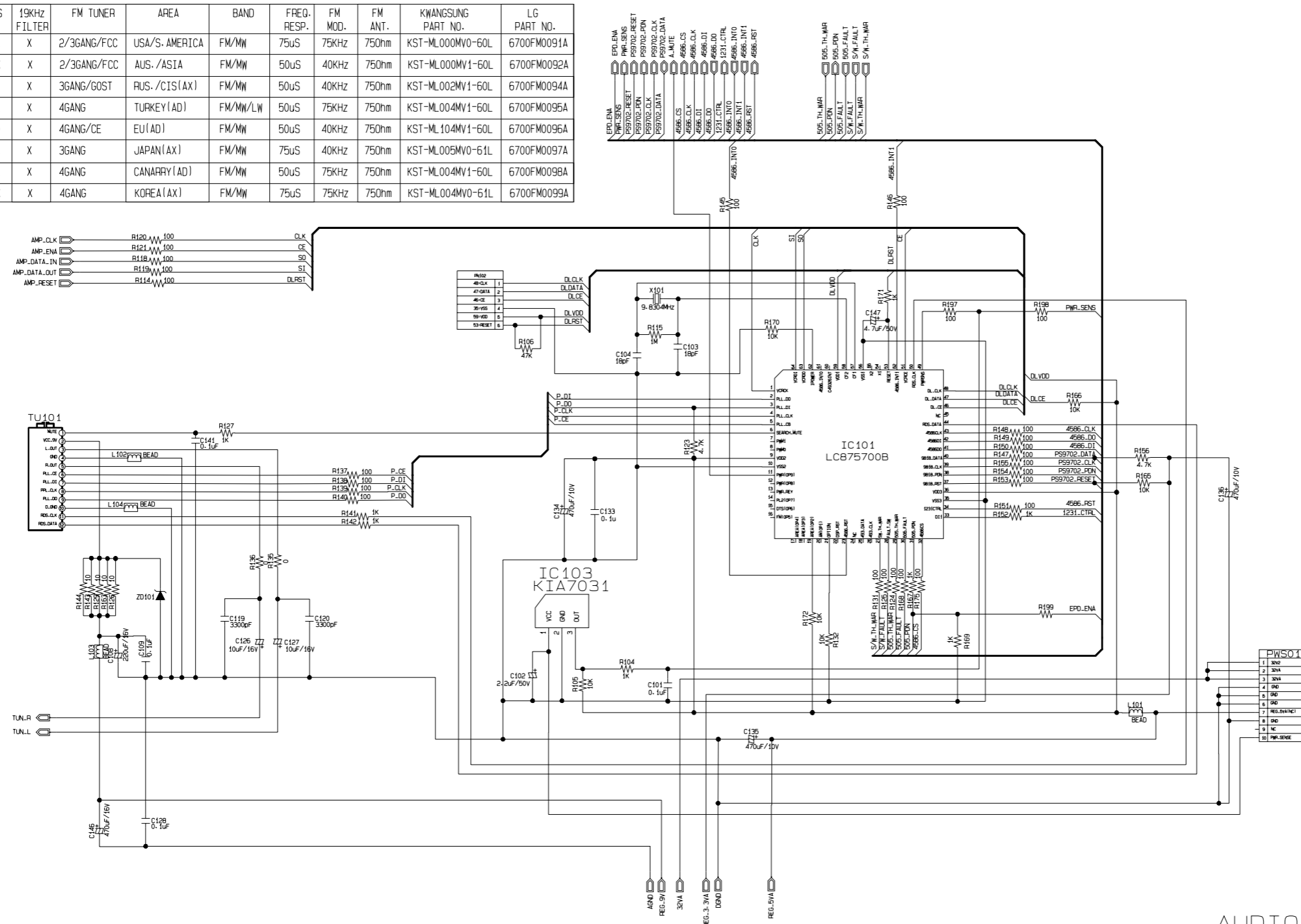

AUDIO MICOM
XH-CW644 2004.08.16
3854R14742A

4. DIGITAL AMP CIRCUIT DIAGRAM (DVD & AMP)_200W

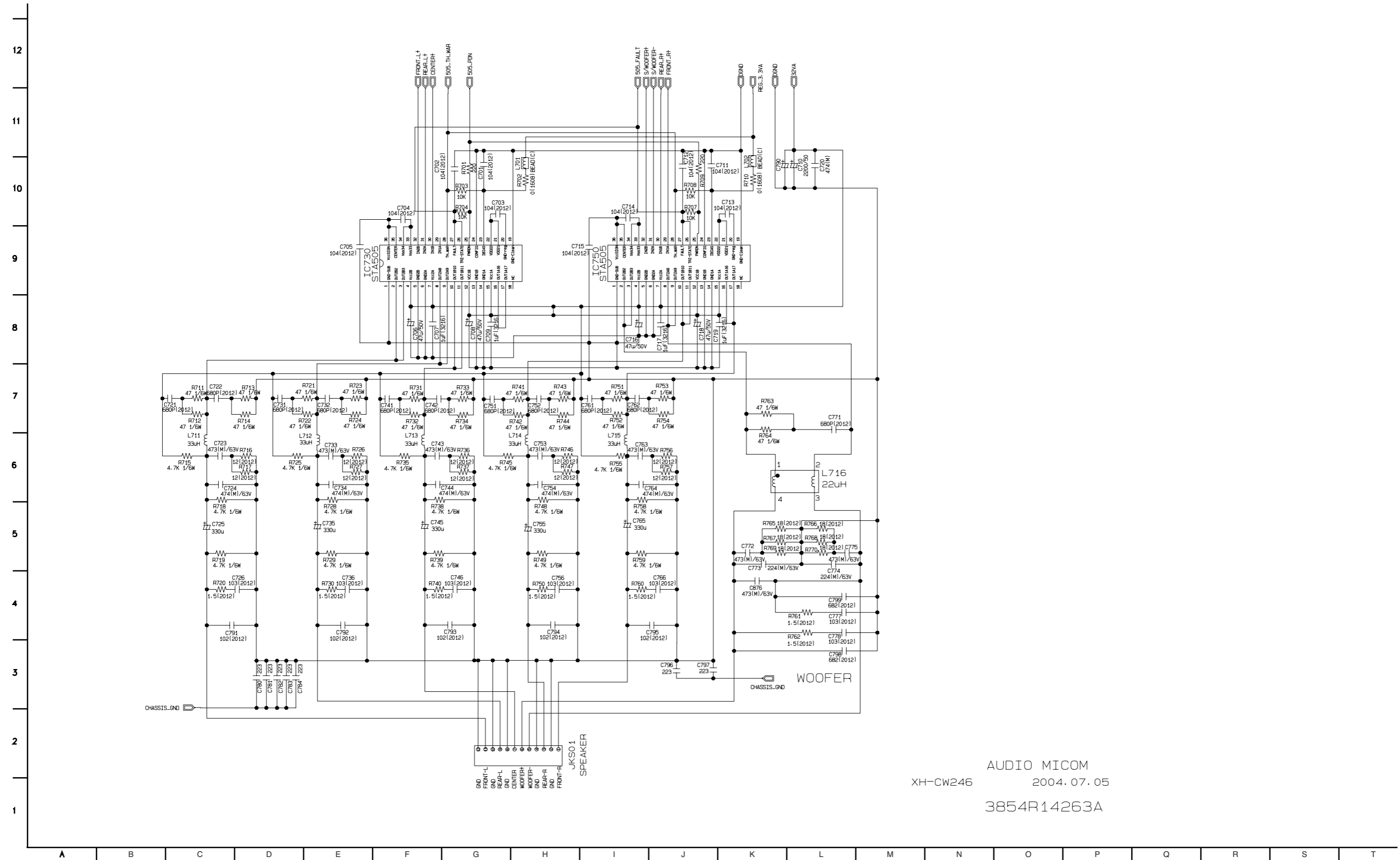

AUDIO MICOM
XH-CW246 2004.07.05
3854R14263A

4. DIGITAL AMP CIRCUIT DIAGRAM (DVD & AMP)_400W

* AMP POWER OPTION

	400W(60/100)	600W(90/150)
R719- 720	X	47132161
R721- 722- 756- 757	X	12120121
R732- 733	X	0120121
C720	X	330P120121
C722- 723	X	104120121
C724- 725	X	1041M
IC710- 730- 750- 770	STAS50B-5C	STAS50B
L711- 722- 731- 742- 752	22uH	15uH
L751	X	15uH
L771- 781	15uH	15uH

* SPEAKER TERMINAL OPTION

	LAN TYPE	SPRING TYPE
DN701 - DN708	TIN	X
DN801 - DN803	X	TIN
W701 - 706	TIN	TIN

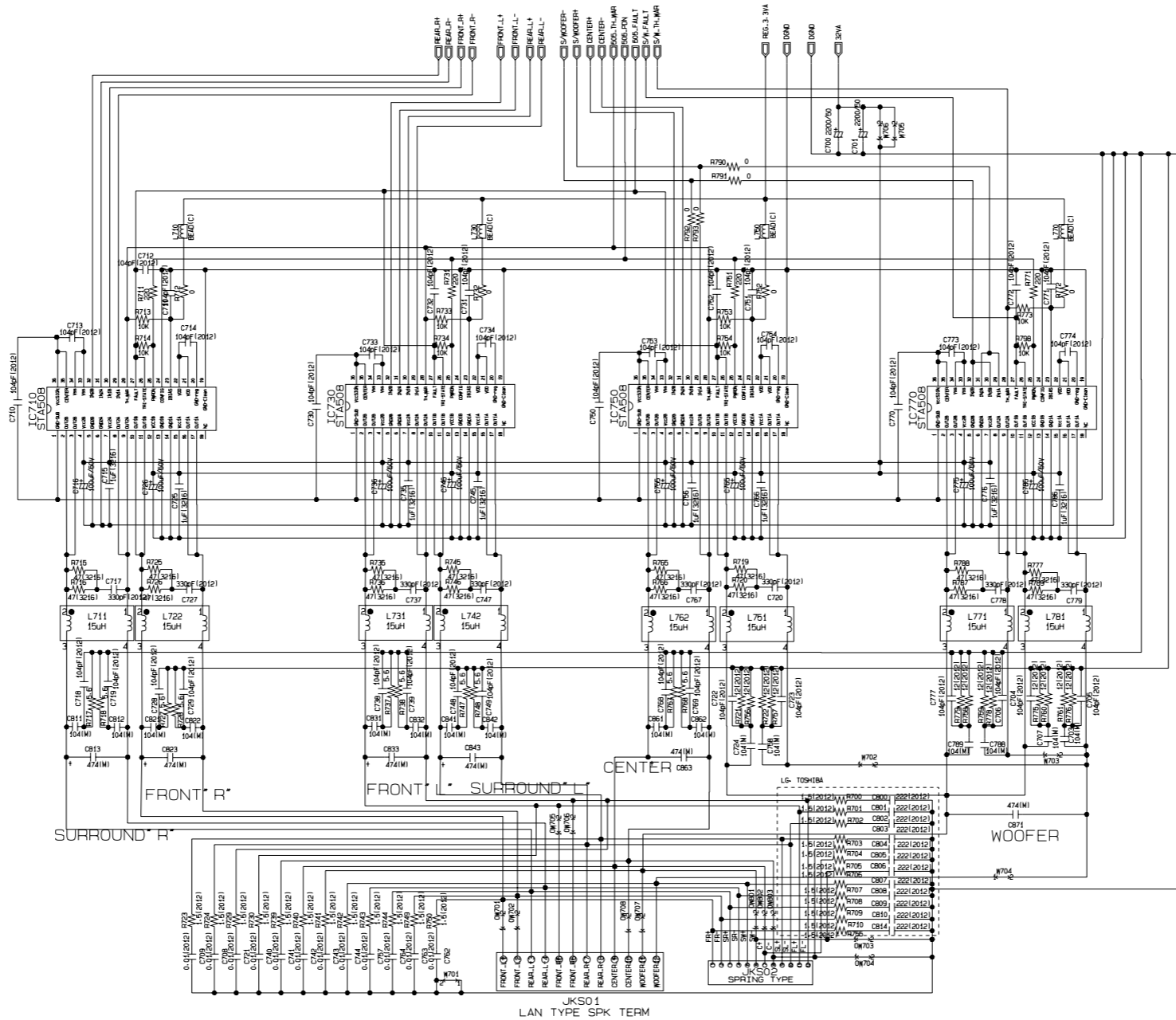

DIGITAL AMP
 XH-CW644 2004.06.30
 3854R14743A

5. PWM & CODEC CIRCUIT DIAGRAM (DVD & AMP)_200W

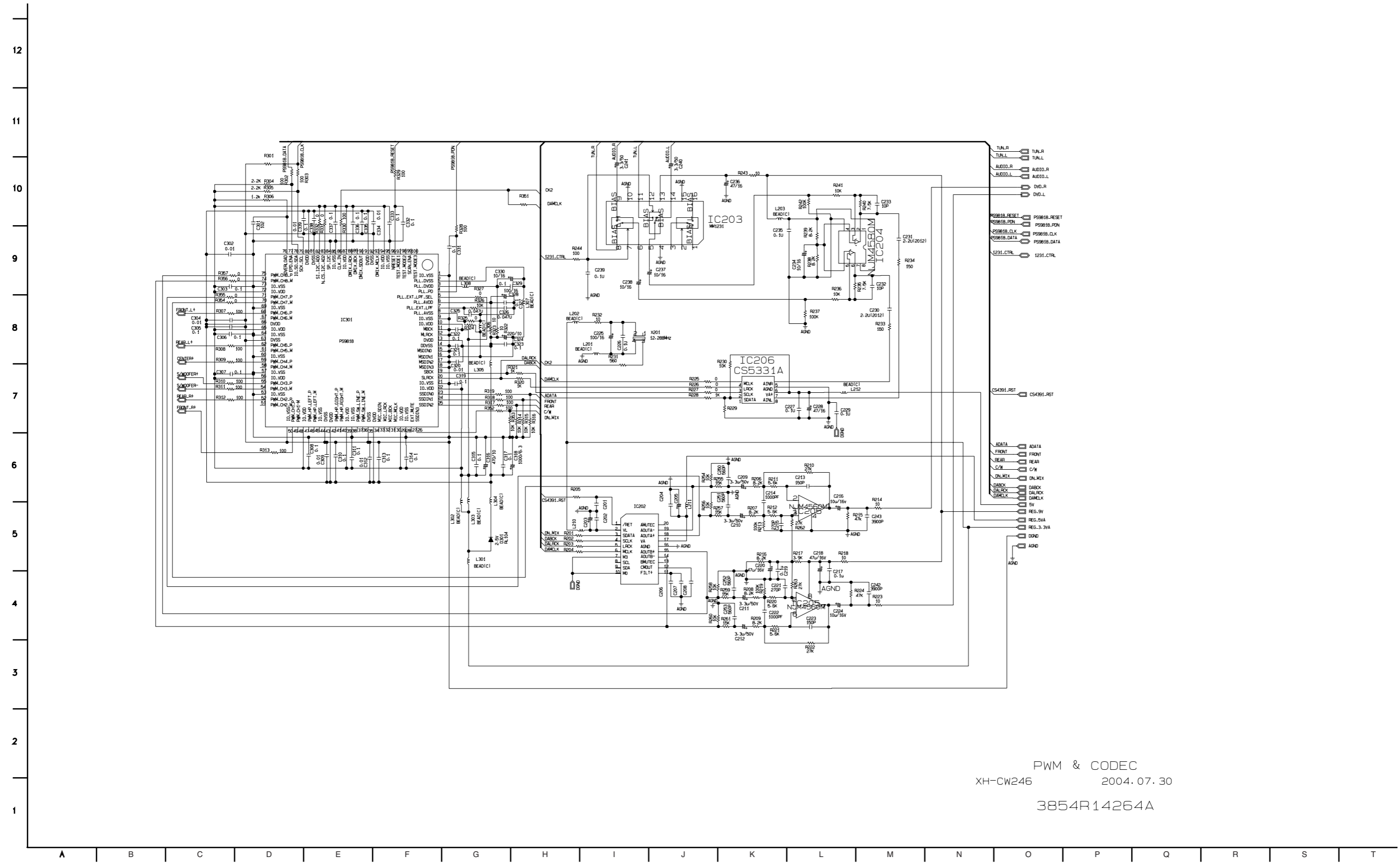

PWM & CODEC
 XH-CW246 2004.07.30
 3854R14264A

5. PWM & CODEIC CIRCUIT DIAGRAM (DVD & AMP)_400W

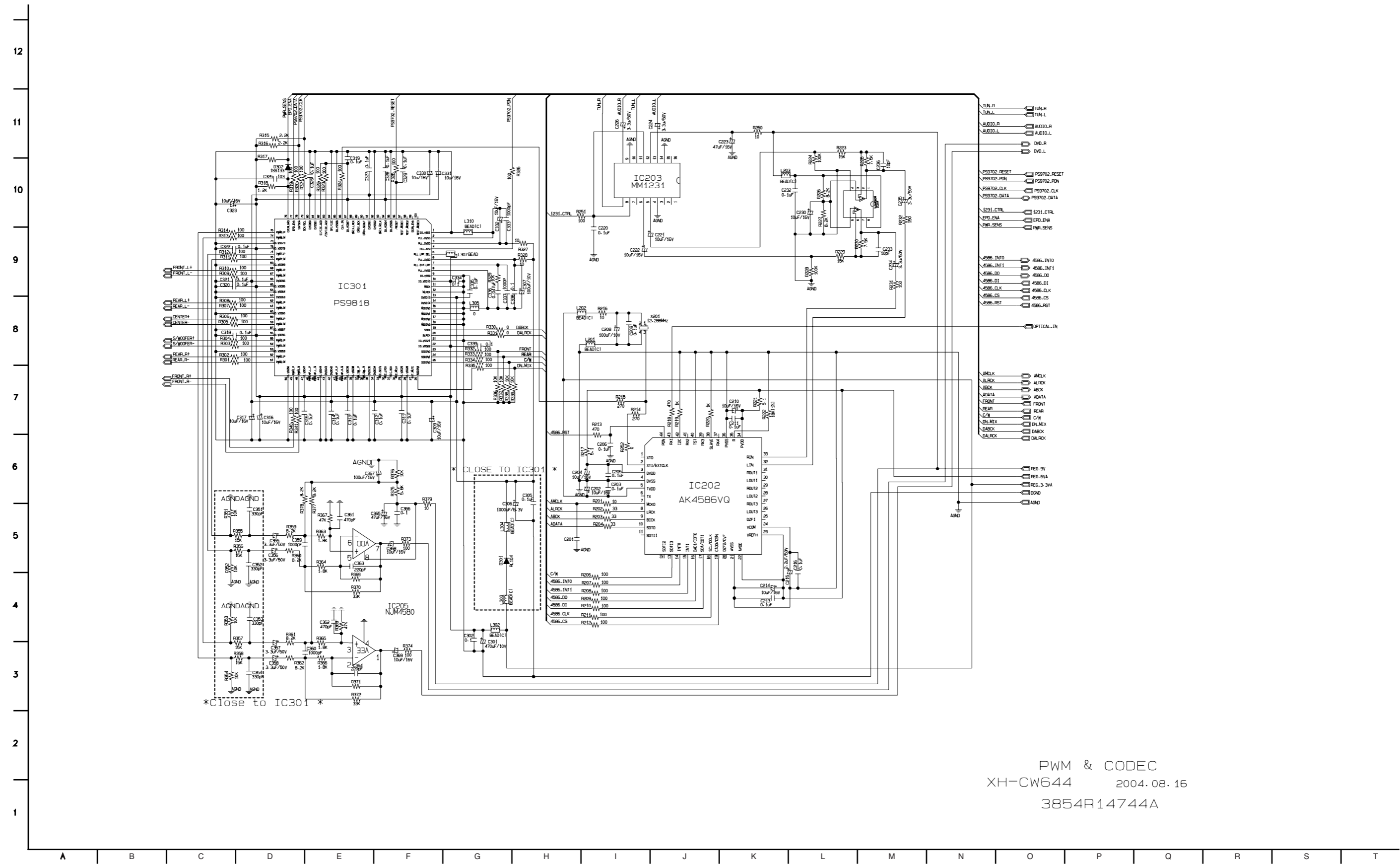

PWM & CODEC
 XH-CW644 2004.08.16
 3854R14744A

6. INTERFACE CIRCUIT DIAGRAM (DVD & AMP)_200W

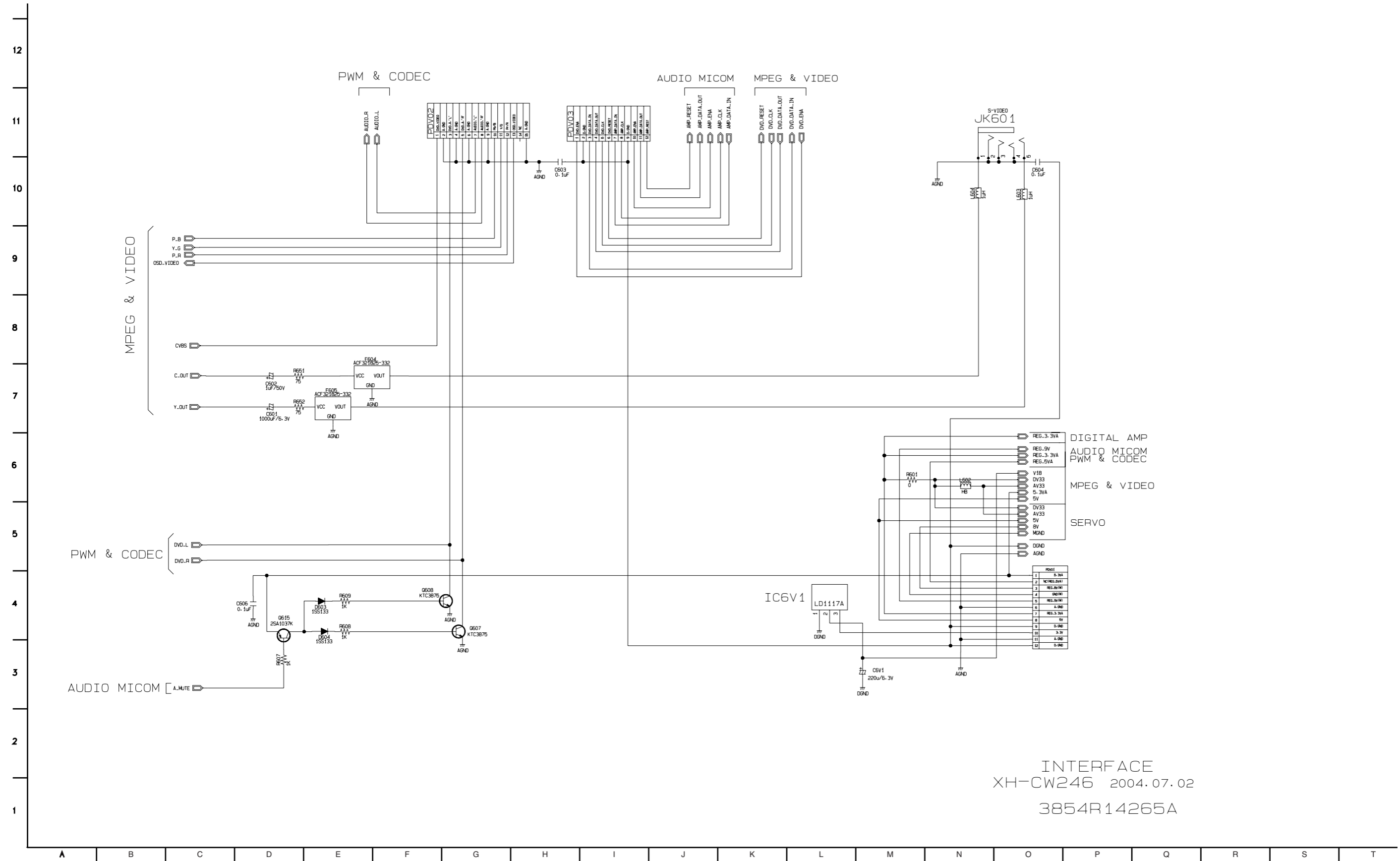

INTERFACE
XH-CW246 2004.07.02
3854R14265A

6. INTERFACE CIRCUIT DIAGRAM (DVD & AMP)_400W

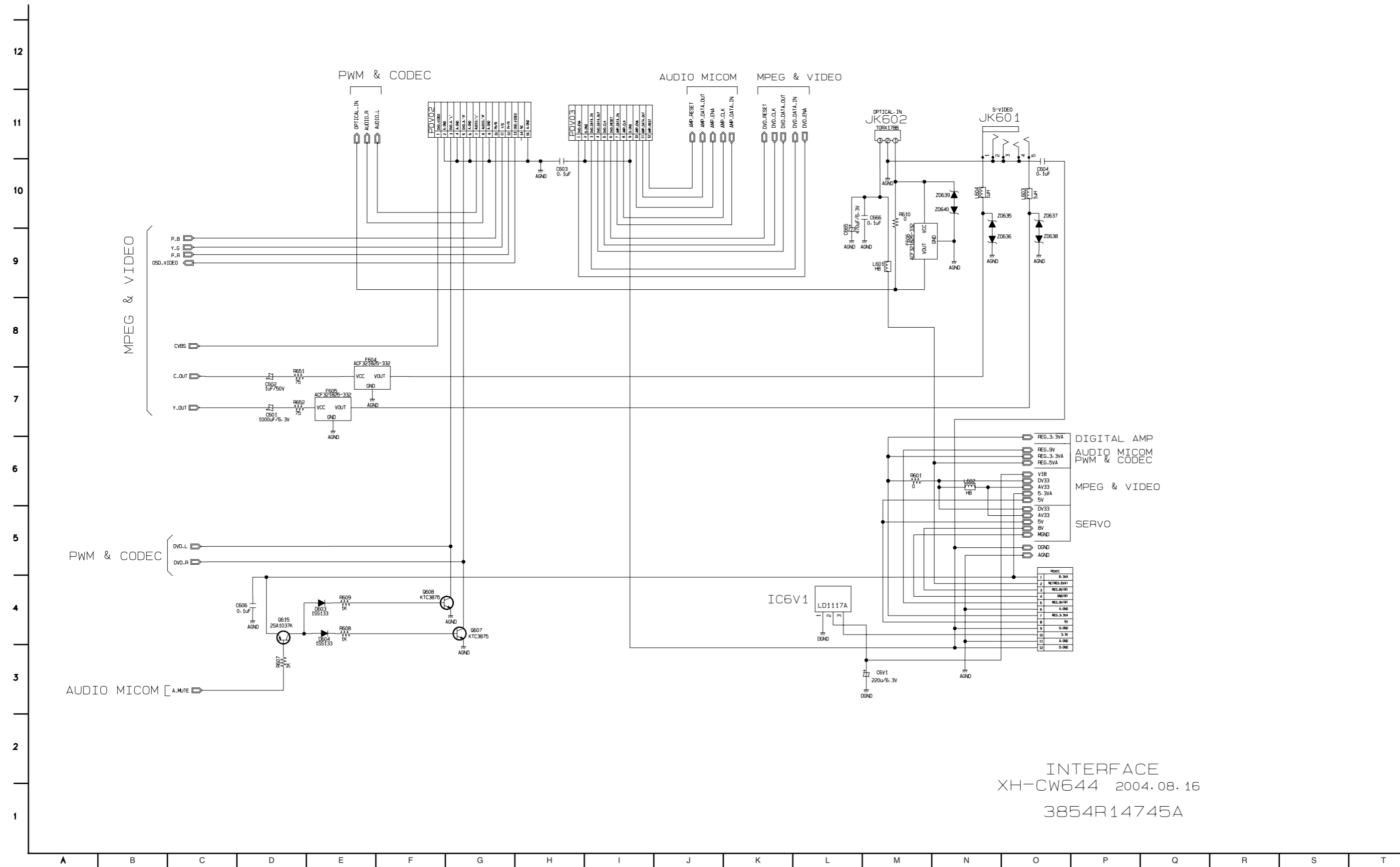

INTERFACE
XH-CW644 2004.08.16
3854R14745A

• CIRCUIT VOLTAGE CHART(200W)

MODE PIN NO.	STOP	PLAY
IC101 (AUDIO. MICOM, LC875700B)		
1	5.13	5.13
2	0.00	0.00
3	5.00	5.00
4	0.00	0.00
5	0.00	0.00
6	5.17	5.17
7	3.08	2.78
8	3.05	2.97
9	4.95	4.95
10	0.00	0.00
11	4.95	4.95
12	0.00	0.00
13	0.00	0.00
14	0.00	0.00
15	0.00	0.00
16	0.00	0.00
17	0.00	0.00
18	0.00	0.00
19	4.94	4.94
20	2.50	2.50
21	0.00	0.00
22	2.54	2.54
23	0.00	0.00
24	0.00	4.94
25	2.54	2.42
26	4.94	4.94
27	3.27	3.27
28	2.22	2.22
29	3.27	3.27
30	2.22	2.22
31	4.54	4.54
32	4.94	4.94
33	0.00	4.86
34	4.94	4.94
35	0.00	0.00
36	4.94	4.94
37	4.91	4.91
38	4.94	4.94
39	4.83	4.40
40	3.27	2.97
41	0.00	0.00
42	1.72	0.37
43	0.00	0.00
44	2.51	0.32
45	2.51	0.34
46	4.93	4.93
47	2.53	0.41
48	2.48	0.40
49	4.93	4.93
50	2.50	2.43
51	4.93	4.93
52	0.00	0.00
53	4.91	4.91
54	2.56	2.56

MODE PIN NO.	STOP	PLAY
55	2.52	2.52
56	0.00	0.00
57	2.44	2.50
58	2.22	2.21
59	4.94	4.94
60	2.54	2.57
61	2.51	2.62
62	0.00	0.00
63	4.94	4.94
64	5.12	5.12
IC103 (RESET IC, KIA7031)		
1	3.79	3.79
2	0.00	0.00
3	4.94	4.94
IC203 (AUDIO SW, MM1231)		
1	5.07	5.02
2	0.00	0.01
3	4.35	4.34
4	0.00	0.00
5	4.35	4.34
6	4.35	4.34
7	4.35	4.34
8	5.08	5.03
9	5.06	5.02
10	0.00	0.00
11	5.07	5.03
12	4.34	4.34
13	9.10	9.10
14	5.05	5.01
15	0.00	0.00
16	5.05	5.01
IC204 (OP AMP, MC4580)		
1	4.88	4.88
2	4.59	4.59
3	4.59	4.59
4	0.00	0.00
5	4.59	4.59
6	4.59	4.59
7	4.89	4.89
8	9.21	9.21
IC205 (OP AMP, NJM4560)		
1	4.30	4.30
2	4.30	4.30
3	4.30	4.30
4	0.00	0.00
5	4.30	4.30
6	4.30	4.30
7	4.30	4.30
8	0.00	0.00
IC301 (PWM IC, PS9818)		
1	0.00	0.00
2	0.00	0.00
3	2.31	2.31
4	4.98	4.98
5	3.18	3.18

MODE PIN NO.	STOP	PLAY
6	2.29	2.29
7	0.48	0.48
8	0.00	0.00
9	0.00	0.00
10	3.18	3.18
11	0.00	0.00
12	0.00	0.00
13	2.31	2.31
14	0.00	0.00
15	0.00	0.00
16	0.00	0.00
17	0.00	0.00
18	0.00	0.00
19	1.62	1.62
20	1.62	1.62
21	0.00	0.00
22	3.18	3.18
23	1.18	1.18
24	0.00	0.00
25	0.00	0.00
26	1.19	1.19
27	0.00	0.00
28	0.00	0.00
29	3.18	3.18
30	1.37	1.37
31	1.52	1.52
32	1.58	1.58
33	0.99	0.99
34	2.33	2.33
35	0.00	0.00
36	1.56	1.56
37	1.56	1.56
38	0.00	0.00
39	3.18	3.18
40	1.56	1.56
41	1.56	1.56
42	2.32	2.32
43	0.00	0.00
44	0.00	0.00
45	1.56	1.56
46	1.56	1.56
47	3.18	3.18
48	1.56	1.56
49	1.56	1.56
50	0.00	0.00
51	1.55	1.55
52	1.54	1.54
53	0.00	0.00
54	1.55	1.55
55	1.55	1.55
56	3.18	3.18
57	0.00	0.00
58	1.54	1.54
59	1.54	1.54
60	0.00	0.00

MODE PIN NO.	STOP	PLAY
61	1.54	1.54
62	1.54	1.54
63	0.00	0.00
64	0.00	0.00
65	3.18	3.18
66	2.32	2.32
67	1.54	1.54
68	1.54	1.54
69	0.00	0.00
70	1.52	1.52
71	1.52	1.52
72	3.18	3.18
73	0.00	0.00
74	1.52	1.52
75	1.52	1.52
76	3.14	3.14
77	3.18	3.18
78	2.87	2.87
79	4.16	4.16
80	2.34	2.34
81	0.00	0.00
82	3.19	3.19
83	3.19	3.19
84	0.00	0.00
85	0.00	0.00
86	1.60	1.60
87	3.19	3.19
88	1.54	1.54
89	1.38	1.38
90	0.00	0.00
91	2.33	2.33
92	0.00	0.00
93	1.28	1.28
94	3.19	3.19
95	0.00	0.00
96	4.93	4.93
97	0.07	0.07
98	0.06	0.06
99	0.12	0.12
100	0.20	0.20
IC402 (MD DRIVE, IP4504A)		
1	1.37	1.37
2	2.65	2.65
3	2.64	2.64
4	2.65	2.65
5	2.72	2.72
6	2.69	2.69
7	2.67	2.67
8	0.00	0.00
9	1.35	1.35
10	3.58	3.58
11	0.00	0.00
12	0.00	0.00
13	3.94	3.94
14	3.94	3.94

MODE PIN NO.	STOP	PLAY
IC501 (MPEG, MTK1389)		
1	0	0
2	1.67	1.67
3	1.67	1.67
4	1.67	1.67
5	1.67	1.67
6	1.67	1.67
7	1.67	1.67
8	1.99	1.99
9	2.0	2.0
10	2.0	2.0
11	2.0	2.0
12	1.40	1.40
13	1.47	1.41
14	1.47	1.47
15	1.44	1.44
16	1.53	1.53
17	1.54	1.43
18	1.96	2.10
19	1.96	2.06
20	0.00	0.18
21	1.05	
22	3.24	2.34
23	3.24	3.21
24	3.24	3.22
25	1.51	1.55
26	0.71	1.93
27	0.00	0
28	2.70	2.71
29	1.96	1.96
30	1.37	1.37
31	1.40	1.32
32	1.27	1.33
33	1.27	1.33
34	2.96	2.80
35	3.24	2.78
36	3.03	2.34
37	1.37	2.04
38	1.37	1.33
39	0.00	0
40	1.37	1.37

MODE PIN NO.	STOP	PLAY
41	1.37	1.37
42	1.37	1.4
43	0.00	0
44	1.57	1.57
45	1.57	1.57
46	3.28	3.28
47	2.96	2.84
48	3.28	3.28
49	0.00	0.00
50	3.26	3.24
51	0.00	0.00
52	1.80	1.80
53	1.97	2.12
54	2.00	1.89
55	1.92	1.76
56	2.14	1.45
57	2.02	1.72
58	2.04	2.23
59	1.39	1.50
60	1.12	0.02
61	0.00	0.00
62	0.00	0.00
63	1.89	1.96
64	0.00	0.00
65	3.16	3.15
66	3.28	3.27
67	1.35	0.27
68	1.41	0.62
69	1.14	0.65
70	2.59	3.00
71	0.33	1.30
72	2.19	1.80
73	3.28	3.27
74	1.72	1.71
75	1.99	2.51
76	0.00	0.00
77	0.00	0.00
78	2.00	2.08
79	0.00	0.00
80	3.27	3.27
81	1.27	1.53
82	1.58	1.52
83	0.86	1.23
84	0.69	0.96
85	0.00	0.00
86	1.49	1.30
87	1.69	1.68
88	1.40	1.32
89	0.00	0.00
90	1.17	1.17
91	1.43	1.34
92	0.31	0.31
93	2.05	1.88
94	0.00	0.00
95	3.15	2.61

MODE PIN NO.	STOP	PLAY
96	3.25	3.22
97	1.80	1.80
98	2.51	2.51
99	2.51	2.51
100	3.25	3.25
101	3.25	3.25
102	3.27	3.27
103	3.27	3.27
104	2.58	2.50
105	1.30	1.30
106	2.51	2.51
107	3.27	3.27
108	3.27	3.27
109	0.00	0.00
110	5.18	5.18
111	3.35	2.52
112	2.60	2.60
113	2.40	1.93
114	0.00	0.02
115	0.84	1.00
116	0.00	0.00
117	0.68	1.25
118	0.99	1.07
119	0.00	0.00
120	0.93	1.82
121	1.32	2.35
122	1.80	1.80
123	1.35	1.14
124	0.99	1.13
125	1.13	1.27
126	0.68	1.33
127	3.27	3.27
128	1.46	1.30
129	1.25	1.40
130	1.00	1.30
131	1.34	1.20
132	0.80	0.90
133	0.83	0.95
134	0.00	0.00
135	1.00	1.00
136	3.29	3.28
137	2.39	2.00
138	3.19	3.10
139	2.93	2.70
140	3.12	3.10
141	3.27	3.27
142	2.57	2.57
143	1.54	1.54
144	0.00	0.00
145	1.60	1.60
146	0.06	0.06
147	0.60	0.60
148	0.00	0.00
149	2.36	1.95
150	2.24	2.00

MODE PIN NO.	STOP	PLAY
151	1.42	1.46
152	1.80	1.80
153	0.60	0.37
154	1.48	1.48
155	3.27	3.27
156	1.66	1.66
157	1.23	1.70
158	0.00	0.00
159	0.07	0.00
160	0.05	0.00
161	0.00	0.00
162	1.24	1.43
163	0.00	0.00
164	1.38	1.45
165	1.55	1.59
166	1.43	1.43
167	3.27	3.27

MODE PIN NO.	STOP	PLAY
50	1.71	1.10
51	2.27	1.26
52	0.00	0.00
53	0.11	1.05
54	0.00	0.00
IC507 (SW, MN1623)		
1	5.18	5.18
2	2.46	2.46
3	5.19	5.19
4	1.31	1.31
5	0.00	0.00
6	1.55	1.55
7	0.00	0.00
8	2.51	2.51
9	0.00	0.00
10	1.55	1.55
11	0.00	0.00
12	2.46	2.46
13	5.19	5.19
14	2.46	2.46
15	0.00	0.00
16	2.52	2.52
17	0.00	0.00
18	2.52	2.52
19	0.00	0.00
20	2.09	2.09
21	2.06	2.06
22	0.00	0.00
23	2.00	2.00
24	0.00	0.00
25	0.00	0.00
26	2.47	2.47
27	0.00	0.00
28	5.19	5.19
IC5A1 (16MB FLASH)		
1	1.31	0.27
2	1.44	0.7
3	1.25	0.7
4	2.62	3
5	0.46	1.2
6	2.1	1.9
7	1.74	1.82
8	1.96	2.52
9	0	0
10	0	0
11	3.27	3.26
12	5.17	5.17
13	3.27	3.27
14	3.27	3.27
15	2.63	2.63
16	0	0
17	1.05	0
18	1.4	1.63
19	2.05	2.25
20	2.04	1.73

MODE PIN NO.	STOP	PLAY
21	0.81	1.54
22	0.8	1.75
23	2.36	1.9
24	2.21	2.12
25	1.98	2.09
26	0	0
27	0	0
28	0	0
29	1.45	1.74
30	1.64	1.14
31	0.47	1.48
32	0.85	1.24
33	0.26	0.88
34	1.06	1.08
35	0.7	0.97
36	1.27	1.00
37	3.27	3.26
38	1.49	1.3
39	1.12	1.1
40	1.64	1.72
41	1.18	1.1
42	1.4	1.3
43	1.04	1.17
44	1.42	1.33
45	2.04	1.88
46	0	0
47	0	0
48		
IC730 (AMP, STA505)		
1	0.00	0.00
2	17.27	17.27
3	17.27	17.27
4	35.31	35.31
5	0.00	0.00
6	0.00	0.00
7	35.31	35.31
8	17.29	17.29
9	17.29	17.29
10	17.27	17.27
11	17.27	17.27
12	35.31	35.31
13	0.31	0.31
14	0.33	0.33
15	35.31	35.31
16	35.31	35.31
17	35.31	35.31
18	0.00	0.43
19	0.00	0.00
20	0.02	0.00
21	4.98	4.98
22	4.98	4.98
23	3.27	3.27
24	0.00	0.00
25	2.27	2.27
26	2.27	2.27
27	2.27	2.27
28	3.27	3.27
29	0.30	0.30
30	1.55	1.55
31	1.55	1.55
32	1.55	1.55
33	30.11	30.11
34	30.11	30.11
35	35.31	35.31
36	35.31	35.31
IC6V1 (REGULATOR, LD1117A)		
1	0.00	0.00
2	1.80	1.80
3	3.30	3.30

MODE PIN NO.	STOP	PLAY
27	2.27	2.27
28	3.27	3.27
29	0.30	0.30
30	1.55	1.55
31	1.55	1.55
32	1.55	1.55
33	30.11	30.11
34	30.11	30.11
35	35.31	35.31
36	35.31	35.31
IC750 (AMP, STA505)		
1	0.00	0.00
2	17.27	17.27
3	17.27	17.27
4	35.31	35.31
5	0.00	0.00
6	0.00	0.00
7	35.31	35.31
8	17.29	17.29
9	17.29	17.29
10	17.27	17.27
11	17.27	17.27
12	35.31	35.31
13	0.31	0.31
14	0.33	0.33
15	35.31	35.31
16	35.31	35.31
17	35.31	35.31
18	0.00	0.43
19	0.00	0.00
20	0.02	0.00
21	4.98	4.98
22	4.98	4.98
23	3.27	3.27
24	0.00	0.00
25	2.27	2.27
26	2.27	2.27

• CIRCUIT VOLTAGE CHART(400W)

MODE PIN NO.	STOP	PLAY
IC101 (AUDIO. MICOM, LC875700B)		
1	5.13	5.13
2	0.00	0.00
3	5.00	5.00
4	0.00	0.00
5	0.00	0.00
6	5.17	5.17
7	3.08	2.78
8	3.05	2.97
9	4.95	4.95
10	0.00	0.00
11	4.95	4.95
12	0.00	0.00
13	0.00	0.00
14	0.00	0.00
15	0.00	0.00
16	0.00	0.00
17	0.00	0.00
18	0.00	0.00
19	4.94	4.94
20	2.50	2.50
21	0.00	0.00
22	2.54	2.54
23	0.00	0.00
24	0.00	4.94
25	2.54	2.42
26	4.94	4.94
27	3.27	3.27
28	2.22	2.22
29	3.27	3.27
30	2.22	2.22
31	4.54	4.54
32	4.94	4.94
33	0.00	4.86
34	4.94	4.94
35	0.00	0.00
36	4.94	4.94
37	4.91	4.91
38	4.94	4.94
39	4.83	4.40
40	3.27	2.97
41	0.00	0.00
42	1.72	0.37
43	0.00	0.00
44	2.51	0.32
45	2.51	0.34
46	4.93	4.93
47	2.53	0.41
48	2.48	0.40
49	4.93	4.93
50	2.50	2.43
51	4.93	4.93
52	0.00	0.00
53	4.91	4.91
54	2.56	2.56

MODE PIN NO.	STOP	PLAY
55	2.52	2.52
56	0.00	0.00
57	2.44	2.50
58	2.22	2.21
59	4.94	4.94
60	2.54	2.57
61	2.51	2.62
62	0.00	0.00
63	4.94	4.94
64	5.12	5.12
IC103 (RESET IC, KIA7031)		
1	3.79	3.79
2	0.00	0.00
3	4.94	4.94
IC202 (CODEC, AK4586VQ)		
1	2.77	2.71
2	1.64	1.64
3	4.94	4.86
4	0.00	0.00
5	3.27	3.27
6	0.00	0.00
7	1.46	1.47
8	0.00	1.63
9	0.00	1.60
10	0.00	1.21
11	2.30	2.41
12	0.00	0.86
13	0.00	0.61
14	0.00	0.00
15	0.00	0.00
16	1.40	0.75
17	0.00	0.00
18	0.00	0.00
19	4.94	4.93
20	0.00	0.00
21	0.00	0.00
22	4.95	4.94
23	4.95	4.94
24	2.47	2.45
25	0.00	0.00
26	2.47	2.41
27	2.49	2.40
28	2.50	2.46
29	2.50	2.46
30	2.50	2.46
31	2.50	2.46
32	2.70	2.46
33	3.16	2.46
34	4.95	4.91
35	0.00	1.19
36	0.00	0.00
37	0.00	2.42
38	0.00	0.00
39	0.00	2.42
40	0.00	0.00

MODE PIN NO.	STOP	PLAY
41	0.00	2.42
42	0.00	0.00
43	0.14	0.14
44	4.94	4.94
IC203 (AUDIO SW, MM1231)		
1	5.07	5.02
2	0.00	0.01
3	4.35	4.34
4	0.00	0.00
5	4.35	4.34
6	4.35	4.34
7	4.35	4.34
8	5.08	5.03
9	5.06	5.02
10	0.00	0.00
11	5.07	5.03
12	4.34	4.34
13	9.10	9.10
14	5.05	5.01
15	0.00	0.00
16	5.05	5.01
IC204 (OP AMP, MC4580)		
1	4.88	4.88
2	4.59	4.59
3	4.59	4.59
4	0.00	0.00
5	4.59	4.59
6	4.59	4.59
7	4.89	4.89
8	9.21	9.21
IC205 (OP AMP, NJM4560)		
1	4.30	4.30
2	4.30	4.30
3	4.30	4.30
4	0.00	0.00
5	4.30	4.30
6	4.30	4.30
7	4.30	4.30
8	0.00	0.00
IC301 (PWM IC, PS9818)		
1	0.00	0.00
2	0.00	0.00
3	2.43	2.43
4	4.94	4.94
5	3.28	3.28
6	2.41	2.41
7	1.08	1.08
8	0.00	0.00
9	0.00	0.00
10	3.28	3.28
11	0.00	0.00
12	0.00	0.00
13	2.43	2.43
14	0.00	0.00
15	0.00	0.00

MODE PIN NO.	STOP	PLAY
16	0.00	0.00
17	0.00	0.00
18	0.00	0.00
19	1.62	1.62
20	1.61	1.61
21	0.00	0.00
22	3.28	3.28
23	0.00	1.20
24	0.00	0.00
25	0.00	0.59
26	0.00	1.20
27	0.00	0.00
28	0.00	0.00
29	3.28	3.28
30	1.50	1.50
31	1.59	1.59
32	1.62	1.62
33	0.06	0.06
34	2.44	2.44
35	0.00	0.00
36	1.60	1.60
37	1.60	1.60
38	0.00	0.00
39	3.28	3.28
40	1.61	1.61
41	1.61	1.61
42	2.44	2.44
43	0.00	0.00
44	0.00	0.00
45	0.00	0.00
46	0.00	0.00
47	3.28	3.28
48	0.00	0.00
49	0.00	0.00
50	0.00	0.00
51	1.60	1.60
52	1.60	1.60
53	0.00	0.00
54	1.60	1.60
55	3.28	3.28
56	0.00	0.00
57	0.00	0.00
58	1.60	1.60
59	1.60	1.60
60	0.00	0.00
61	1.60	1.60
62	1.60	1.60
63	0.00	0.00
64	0.00	0.00
65	3.28	3.28
66	2.42	2.42
67	1.60	1.60
68	1.60	1.60
69	0.00	0.00
70	1.60	1.60

MODE PIN NO.	STOP	PLAY
71	1.60	1.60
72	3.28	3.28
73	0.00	0.00
74	1.60	1.60
75	1.60	1.60
76	3.24	3.24
77	3.28	3.28
78	2.95	2.95
79	4.33	4.33
80	2.42	2.42
81	0.00	0.00
82	3.27	3.27
83	3.27	3.27
84	0.00	0.00
85	0.00	0.00
86	1.64	1.64
87	3.27	3.27
88	1.61	1.61
89	1.55	1.55
90	1.21	1.21
91	2.43	2.43
92	0.00	0.00
93	1.48	1.48
94	3.28	3.28
95	0.00	0.00
96	4.89	4.89
97	0.00	0.00
98	0.00	0.00
99	0.00	0.00
100	0.00	0.00
IC402 (MD DRIVE, IP4504A)		
1	1.37	1.37
2	2.65	2.65
3	2.64	2.64
4	2.65	2.65
5	2.72	2.72
6	2.69	2.69
7	2.67	2.67
8	0.00	0.00
9	1.35	1.35
10	3.58	3.58
11	0.00	0.00
12	0.00	0.00
13	3.94	3.94
14	3.94	3.94
15	2.47	2.47
16	5.46	5.46
17	3.72	3.72
18	4.20	4.20
19	8.00	8.00
20	1.37	1.37
21	1.81	1.81
22	1.37	1.37
23	3.23	3.23
24	5.20	5.20

MODE PIN NO.	STOP	PLAY
25	2.54	2.54
26	2.73	2.73
27	2.62	2.62
28	2.65	2.65
IC501 (MPEG, MTK1389)		
1	0	0
2	1.67	1.67
3	1.67	1.67
4	1.67	1.67
5	1.67	1.67
6	1.67	1.67
7	1.67	1.67
8	1.99	1.99
9	2.0	2.0
10	2.0	2.0
11	2.0	2.0
12	1.40	1.40
13	1.47	1.41
14	1.47	1.47
15	1.44	1.44
16	1.53	1.53
17	1.54	1.43
18	1.96	2.10
19	1.96	2.06
20	0.00	0.18
21	1.05	
22	3.24	2.34
23	3.24	3.21
24	3.24	3.22
25	1.51	1.55
26	0.71	1.93
27	0.00	0
28	2.70	2.71
29	1.96	1.96
30	1.37	1.37
31	1.40	1.32
32	1.27	1.33
33	1.27	1.33
34	2.96	2.80
35	3.24	2.78
36	3.03	2.34
37	1.37	2.04
38	1.37	1.33
39	0.00	0
40	1.37	1.37
41	1.37	1.37
42	1.37	1.4
43	0.00	0
44	1.57	1.57
45	1.57	1.57
46	3.28	3.28
47	2.96	2.84
48	3.28	3.28
49	0.00	0.00
50	3.26	3.24

MODE PIN NO.	STOP	PLAY
51	0.00	0.00
52	1.80	1.80
53	1.97	2.12
54	2.00	1.89
55	1.92	1.76
56	2.14	1.45
57	2.02	1.72
58	2.04	2.23
59	1.39	1.50
60	1.12	0.02
61	0.00	0.00
62	0.00	0.00
63	1.89	1.96
64	0.00	0.00
65	3.16	3.15
66	3.28	3.27
67	1.35	0.27
68	1.41	0.62
69	1.14	0.65
70	2.59	3.00
71	0.33	1.30
72	2.19	1.80
73	3.28	3.27
74	1.72	1.71
75	1.99	2.51
76	0.00	0.00
77	0.00	0.00
78	2.00	2.08
79	0.00	0.00
80	3.27	3.27
81	1.27	1.53
82	1.58	1.52
83	0.86	1.23
84	0.69	0.96
85	0.00	0.00
86	1.49	1.30
87	1.69	1.68
88	1.40	1.32
89	0.00	0.00
90	1.17	1.17
91	1.43	1.34
92	0.31	0.31
93	2.05	1.88
94	0.00	0.00
95	3.15	2.61
96	3.25	3.22
97	1.80	1.80
98	2.51	2.51
99	2.51	2.51
100	3.25	3.25
101	3.25	3.25
102	3.27	3.27
103	3.27	3.27
104	2.58	2.50
105	1.30	1.30

MODE PIN NO.	STOP	PLAY
106	2.51	2.51
107	3.27	3.27
108	3.27	3.27
109	0.00	0.00
110	5.18	

PRINTED CIRCUIT DIAGRAMS

1. DVD & AMP P.C.BOARD_200W

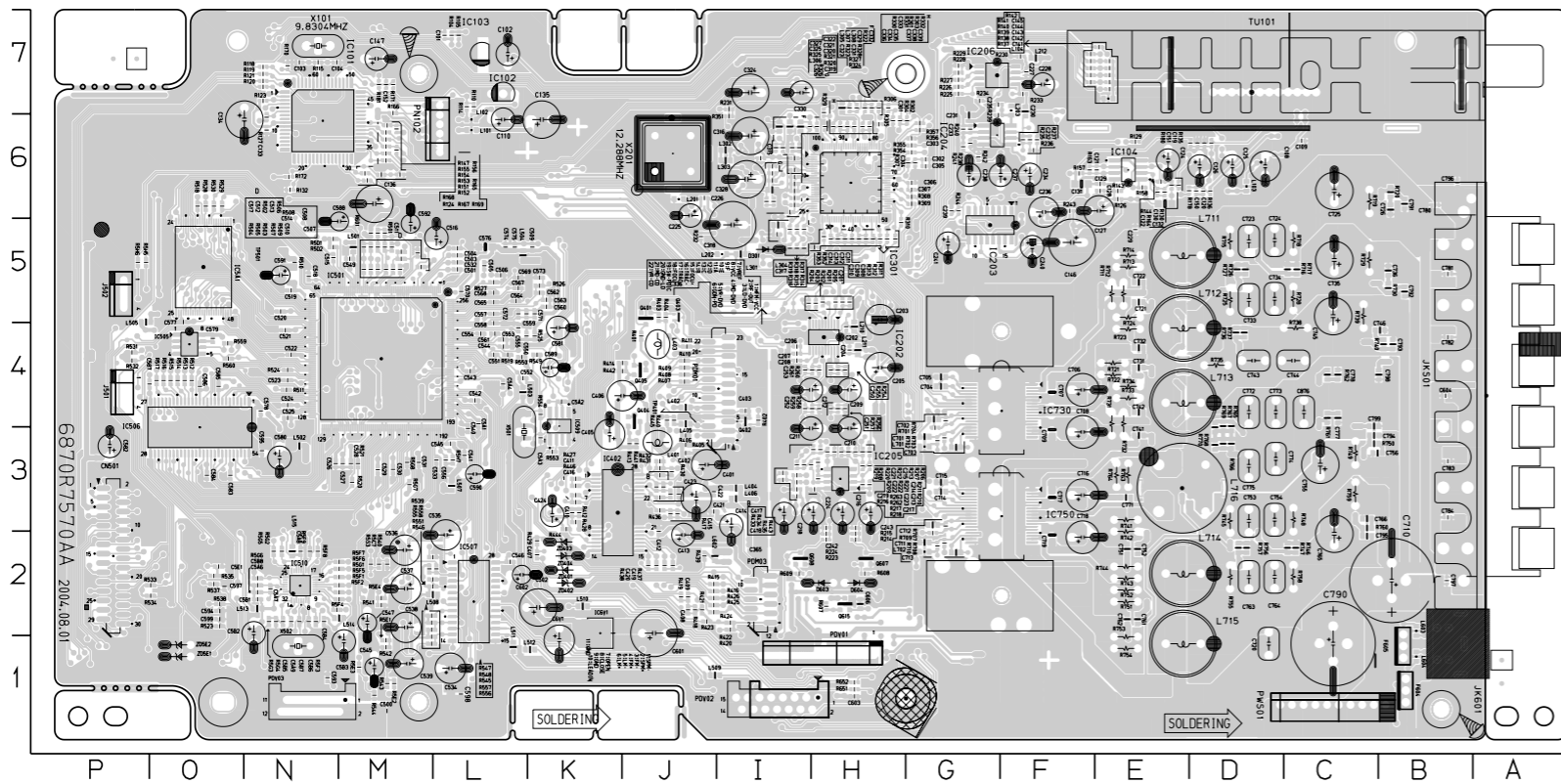

LOCATION GUIDE

C101	E7	C218	I3	C322	H6	C510	D6	C562	F5	C587	C2	C755	N3	C8507	E2	L604	O1	R151	D6	R231	H7	R328	H6	R440	G4	R547	D2	R707	J3	R758	N2
C102	E7	C219	H3	C323	H6	C511	D6	C563	F5	C588	B2	C756	N3	C8508	F4	L701	J3	R152	D6	R232	G5	R329	I7	R441	G3	R548	D2	R708	J2	R759	N3
C103	C7	C220	H3	C324	H7	C512	D6	C564	F5	C591	B2	C757	N3	C8509	F4	L702	J2	R153	D6	R233	G5	R330	I7	R442	G3	R549	F4	R709	J2	R760	N3
C104	C7	C221	I3	C325	H6	C513	D6	C565	F5	C592	E2	C758	N3	C8510	E2	L703	L4	R154	D6	R234	J7	R331	I7	R443	F3	R550	E4	R710	J2	R761	N4
C105	M6	C222	H3	C326	H6	C514	D6	C566	F5	C593	E2	C759	N3	C8511	F2	L704	L4	R155	D6	R235	K6	R332	I7	R444	F3	R551	E2	R711	L5	R762	N4
C106	E6	C223	I3	C327	H6	C515	D6	C567	F5	C594	E2	C760	N3	C8512	F2	L705	L4	R156	D6	R236	K6	R333	I7	R445	F3	R552	F4	R712	L5	R763	L3
C107	M6	C224	I3	C328	H6	C516	D6	C568	F5	C595	E2	C761	N3	C8513	F2	L706	L4	R157	D6	R237	K6	R334	I7	R446	F3	R553	F4	R713	L5	R764	L3
C108	M6	C225	G6	C329	H7	C517	D6	C569	F5	C596	E2	C762	N3	C8514	F2	L707	L4	R158	D6	R238	K6	R335	I7	R447	F3	R554	F4	R714	L5	R765	M3
C109	M6	C226	G6	C330	H7	C518	D6	C570	F5	C597	E2	C763	N3	C8515	F2	L708	L4	R159	D6	R239	K6	R336	I7	R448	F3	R555	D1	R715	M6	R766	M3
C110	E6	C227	K7	C331	H6	C519	D6	C571	F5	C598	E2	C764	N3	C8516	F2	L709	L4	R160	D6	R240	J6	R337	I7	R449	F3	R556	D1	R716	M6	R767	M4
C111	M6	C228	K7	C332	H6	C520	D6	C572	F5	C599	E2	C765	N3	C8517	F2	L710	L4	R161	D6	R241	J6	R338	I7	R450	F3	R557	D1	R717	M6	R768	M3
C112	L6	C229	L5	C333	I7	C521	D6	C573	F5	C600	E2	C766	N3	C8518	F2	L711	L4	R162	D6	R242	J6	R339	I7	R451	F3	R558	D1	R718	M6	R769	M3
C113	L6	C230	L5	C334	I7	C522	D6	C574	F5	C601	E2	C767	N3	C8519	F2	L712	L4	R163	D6	R243	J6	R340	I7	R452	F3	R559	D1	R719	M6	R770	M3
C114	L6	C231	L5	C335	I7	C523	D6	C575	F5	C602	E2	C768	N3	C8520	F2	L713	L4	R164	D6	R244	J6	R341	I7	R453	F3	R560	D1	R720	M6	R771	M3
C115	L6	C232	L5	C336	I7	C524	D6	C576	F5	C603	E2	C769	N3	C8521	F2	L714	L4	R165	D6	R245	J6	R342	I7	R454	F3	R561	D1	R721	M6	R772	M3
C116	L6	C233	L5	C337	I7	C525	D6	C577	F5	C604	E2	C770	N3	C8522	F2	L715	L4	R166	D6	R246	J6	R343	I7	R455	F3	R562	D1	R722	M6	R773	M3
C117	L6	C234	L5	C338	I7	C526	D6	C578	F5	C605	E2	C771	N3	C8523	F2	L716	L4	R167	D6	R247	J6	R344	I7	R456	F3	R563	D1	R723	M6	R774	M3
C118	L6	C235	L5	C339	I7	C527	D6	C579	F5	C606	E2	C772	N3	C8524	F2	L717	L4	R168	D6	R248	J6	R345	I7	R457	F3	R564	D1	R724	M6	R775	M3
C119	M6	C236	K6	C340	H6	C528	D6	C580	F5	C607	E2	C773	N3	C8525	F2	L718	L4	R169	D6	R249	J6	R346	I7	R458	F3	R565	D1	R725	M6	R776	M3
C120	M6	C237	K6	C341	H6	C529	D6	C581	F5	C608	E2	C774	N3	C8526	F2	L719	L4	R170	D6	R250	J6	R347	I7	R459	F3	R566	D1	R726	M6	R777	M3
C121	L6	C238	L5	C342	H6	C530	D6	C582	F5	C609	E2	C775	N3	C8527	F2	L720	L4	R171	D6	R251	J6	R348	I7	R460	F3	R567	D1	R727	M6	R778	M3
C122	L6	C239	L5	C343	H6	C531	D6	C583	F5	C610	E2	C776	N3	C8528	F2	L721	L4	R172	D6	R252	J6	R349	I7	R461	F3	R568	D1	R728	M6	R779	M3
C123	O6	C240	K5	C344	H6	C532	D6	C584	F5	C611	E2	C777	N3	C8529	F2	L722	L4	R173	D6	R253	J6	R350	I7	R462	F3	R569	D1	R729	M6	R780	M3
C124	L6	C241	J5	C345	H6	C533	D6	C585	F5	C612	E2	C778	N3	C8530	F2	L723	L4	R174	D6	R254	J6	R351	I7	R463	F3	R570	D1	R730	M6	R781	M3
C125	M6	C242	H5	C346	H6	C534	D6	C586	F5	C613	E2	C779	N3	C8531	F2	L724	L4	R175	D6	R255	J6	R352	I7	R464	F3	R571	D1	R731	M6	R782	M3
C126	M6	C243	I5	C347	H6	C535	D6	C587	F5	C614	E2	C780	N3	C8532	F2	L725	L4	R176	D6	R256	J6	R353	I7	R465	F3	R572	D1	R732	M6	R783	M3
C127	L6	C244	J5	C348	H6	C536	D6	C588	F5	C615	E2	C781	N3	C8533	F2	L726	L4	R177	D6	R257	J6	R354	I7	R466	F3	R573	D1	R733	M6	R784	M3
C128	L6	C245	J5	C349	H6	C537	D6	C589	F5	C616	E2	C782	N3	C8534	F2	L727	L4	R178	D6	R258	J6	R355	I7	R467	F3	R574	D1	R734	M6	R785	M3
C129	L6	C246	J5	C350	H6	C538	D6	C590	F5	C617	E2	C783	N3	C8535	F2	L728	L4	R179	D6	R259	J6	R356	I7	R468	F3	R575	D1	R735	M6	R786	M3
C130	L6	C247	J5	C351	H6	C539	D6	C591	F5	C618	E2	C784	N3	C8536	F2	L729	L4	R180	D6	R260	J6	R357	I7	R469	F3	R576	D1	R736	M6	R787	M3
C131	M6	C248	K6	C352	H6	C540	D6	C592	F5	C619	E2	C785	N3	C8537	F2	L730	L4	R181	D6	R261	J6	R358	I7	R470	F3	R577	D1	R737	M6	R788	M3
C132	L6	C249	J5	C353	H6	C541	D6	C593	F5	C620	E2	C786	N3	C8538	F2	L731	L4	R182	D6	R262	J6	R359	I7	R471	F3	R578	D1	R738	M6	R789	M3
C133	O6	C250	K5	C354	H6	C542	D6	C594	F5	C621	E2	C787	N3	C8539	F2	L732	L4	R183	D6	R263	J6	R360	I7	R472	F3	R579	D1	R739	M6	R790	M3
C134	O6	C251	K5	C355	H6	C543	D6	C595	F5	C622	E2	C788	N3	C8540	F2	L733	L4	R184	D6	R264	J6	R361	I7	R473	F3	R580	D1	R740	M6	R791	M3
C135	F6	C252	K5	C356	H6	C544	D6	C596	F5	C623	E2	C789	N3	C8541	F2	L734	L4	R185	D6	R265	J6	R362	I7	R474	F3	R581	D1	R741	M6	R792	M3
C136	D6	C253	J5	C357	H6	C545	D6	C597	F5	C624	E2	C790	N3	C8542	F2	L735	L4	R186	D6	R266	J6	R363	I7	R475	F3	R582	D1	R742	M6	R793	M3
C137	L6	C254	J5	C358	H6	C546	D6	C598	F5	C625	E2	C791	N3	C8543	F2	L736	L4	R187	D6	R267	J6	R364	I7	R476	F3	R583	D1	R743	M6	R794	M3
C138	L6	C255	J5	C359	H6	C547	D6	C599	F5	C626	E2	C792	N3	C8544	F2	L737	L4	R188	D6	R268	J6	R365	I7	R477	F3	R584	D1	R744	M6	R795	M3
C139	L6	C256	J5	C360	H6	C548	D6	C600	F5	C627	E2	C793	N3	C8545	F2	L738	L4	R189	D6	R269	J6	R366	I7	R478	F3	R585	D1	R745	M6	R796	M3
C140	L6	C257	J5	C361	H6	C549	D6	C601	F5	C628	E2	C794	N3	C8546	F2	L739	L4	R190	D6	R270	J6	R367	I7	R479	F3	R586	D1	R746	M6	R797	M3
C141	L7	C258	L4	C362	H6	C550	D6	C602	F5	C629	E2	C795	N3	C8547	F2	L740	L4	R191	D6	R271	J6	R368	I7	R480	F3	R587	D1	R747	M6	R798	M3
C142	L7	C259	L4	C363	H6	C551	D6	C603	F5	C630	E2	C796	N3	C8548	F2	L741	L4	R192	D6	R272	J6	R369	I7	R481	F3	R588	D1	R748	M6	R799	M3
C143	L7	C260	L4	C364	H6	C552	D6	C604	F5	C631	E2	C797	N3	C8549	F2	L742	L4	R193	D6	R273	J6	R370	I7	R482	F3	R589	D1	R749	M6	R800	M3
C144	L7	C261	L4	C365	H6	C553	D6	C605	F5	C632	E2	C798	N3	C8550	F2	L743	L4	R194	D6	R274	J6	R371	I7	R483	F3	R590	D1	R750	M6	R801	M3
C145	L7	C262	L4	C366	H6	C554	D6	C606	F5	C633	E2	C799	N3	C8551	F2	L744	L4	R195	D6	R275	J6	R372	I7	R484	F3	R591	D1	R751	M6	R802	M3
C146	K5	C263	J6	C367	H6	C555	D6	C607	F5	C634	E2	C800	N3	C8552	F2	L745	L4	R196	D6	R276	J6	R373	I7	R485	F3	R592	D1	R752	M6	R803	M3
C147	O7	C264	J6	C368	H6	C556	D6	C608	F5	C635	E2	C801	N3	C8553	F2	L746	L4	R197	D6	R277	J6	R374	I7	R486	F3	R593	D1	R753	M6	R804	M3
C148	K5	C265	J6	C369	H6	C557	D6	C609	F5	C636	E2	C802	N3	C8554	F2	L747	L4	R198	D6	R278	J6	R375	I7	R487	F3	R594	D1	R754	M6	R805	M3
C149	O7	C266	J6	C370	H6	C558	D6	C610	F5	C637	E2	C803	N3	C8555	F2	L748	L4	R199	D6	R279	J6	R376	I7	R488	F3	R595	D1	R755	M6	R806	M3
C150	M6	C267	J6	C371	H6	C559	D6	C611	F5	C638	E2	C804	N3	C8556	F2	L749	L4	R200	D6	R280	J6	R377	I7	R489	F3	R596	D1	R756	M6	R807	M3
C151	M6	C268	J6	C372	H6	C560	D6	C612	F5	C639	E2	C805	N3	C8557	F2	L750	L4	R201	D6	R281	J6	R378	I7	R490	F3	R597	D1	R757	M6	R808	M3
C152	O7	C384	J6	C417	H6	C543	D6	C597	F5	C627	E2	C795	N3	C8512	F2	L715	L4	R187	D6	R254	J6	R353	I7	R463	F3	R572	D1	R733	M6	R783	M3
C153	O7	C385	J6	C418	H6	C544	D6	C598	F5	C628	E2	C796	N3	C8513	F2	L716	L4	R188	D6	R255											

MEMO

A series of horizontal dotted lines for writing on the left page.

MEMO

A series of horizontal dotted lines for writing on the right page.

SECTION 4 MECHANISM OF VCR PART (D-37)

CONTENTS

POSITION DRAWING OF DECK MECHANISM PARTS

- Top View4-1
- Bottom View4-1

DISASSEMBLY AND ASSEMBLY OF DECK MECHANISM

01. Assembly and disassembly of Drum.....	4-2
02. Plate Top disassembly	4-4
03. Holder Assembly CST	4-4
04. Disassembly of Gear Assembly Rack F/L.....	4-4
05. Opener Door	4-4
06. Arm Assembly F/L.....	4-4
07. Lever Assembly S/W.....	4-4
08. Motor Assembly L/D.....	4-5
09. Gear Wheel.....	4-5
10. Arm Assembly Cleaner.....	4-5
11. Head F/E.....	4-5
12. Base Assembly A/C Head	4-5
13. Brake Assembly T	4-6
14. Arm Assembly Tension.....	4-6
15. Reel S / Reel T.....	4-6
16. Base Assembly P4	4-7
17. Opener Lid	4-7
18. Arm Assembly Pinch	4-7
19. Arm T/up	4-7
20. Supporter, Capstan	4-8
21. Belt Capstan/Motor Capstan	4-8
22. Lever F/R	4-8
23. Clutch Assembly D37	4-8
24. Gear Drive/Gear Cam	4-9
25. Gear Sector.....	4-9
26. Brake Assembly Capstan	4-9
27. Plate Slider.....	4-9
28. Lever Tension.....	4-9
29. Lever Spring.....	4-9
30. Lever Brake.....	4-9
31. Gear Assembly P2/Gear Assembly P3 ...	4-10
32. Base Assembly P2/Base Assembly P3 ...	4-10
33. Base Loading	4-10
34. Base Tension.....	4-11
35. Arm Assembly Idler Jog	4-11

DECK MECHANISM ADJUSTMENT

- Fixtures and tools for service4-12
- 1. Check of Mechanism Assembly Mode4-13
- 2. Previous Preparation for
 Deck Adjustment 4-14 |
- 3. Torque Measuring 4-14 |
- 4. Adjustment of Guide Roller Height.....4-15
 - 4-1. Prior Adjustment.....4-15
 - 4-2. Fine Adjustment.....4-15
- 5. Adjustment of Audio/Control (A/C) Head..4-16
 - 5-1. Prior Adjustment.....4-16
 - 5-2. Check of Tape Path between Pinch
 Roller and Take-up Guide 4-17 |
 - 5-3. Fine Adjustment
 (Azimuth Adjustment)..... 4-17 |
- 6. X-distance Adjustment 4-17 |
- 7. Adjustment of Drum Assembly
 (Video Heads) 4-18 |
- 8. Tachometer Adjustment of
 Deck Assembly..... 4-18 |
- 8-1. Check of Audio, RF Normalization
 Time (Locking Time) in Play after
 CUE or REV..... 4-18 |
- 8-2. Check of Tape Curl and
 Jam Status..... 4-18 |

MAINTENANCE AND CHECK OF VIDEO FUNCTION

- 1. Checking Points before Repair 4-19 |
- 2. Essential Check and Maintenance..... 4-20 |
- 3. Regular Check and Maintenance..... 4-20 |
- 4. Tools for Check and Maintenance..... 4-20 |
- 5. Maintenance Course 4-20 |
- 5-1. Removal of Foreign Materials..... 4-20 |
- 5-2. Grease Application..... 4-21 |

GUIDE FOR TROUBLESHOOTING

- 1. Deck Mechanism..... 4-23 |
- 2. Front Loading Mechanism..... 4-26 |

EXPLODED VIEWS

- 1. Front Loading Mechanism Section..... 4-28 |
- 2. Moving Mechanism Section(1) 4-29 |
- 3. Moving Mechanism Section(2) 4-30 |

POSITION DRAWING OF DECK MECHANISM PARTS

• Top View

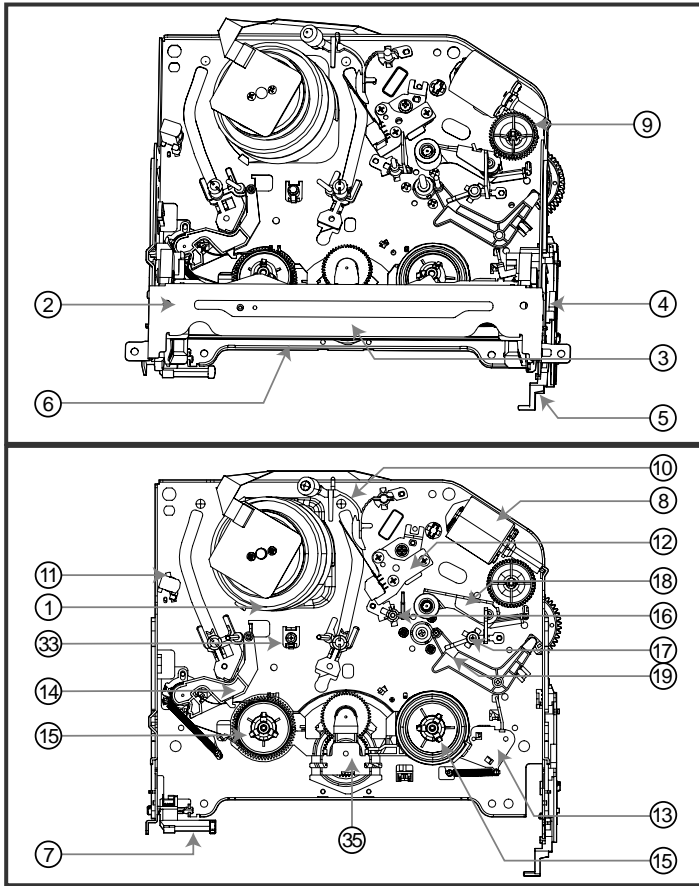

• Bottom View

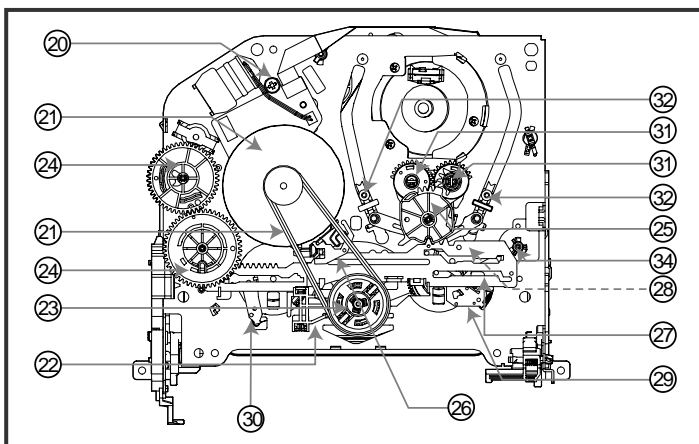

Order Of Dis- assembled Parts firstly Disassembled	Part	Fixing Type	Ref. Draw- ings	Posi tion
	1 Drum Assembly	3 screws	A-1	T
	2 Plate Top	2 hooks	A-2	T
2	3 Holder Assembly CST	6 chasses	A-2	T
2,3	4 Gear Assembly Rack F/L	1 hook	A-2	T
2,3,4	5 Opener Door	Chassis Hole	A-2	T
2,3,4,5	6 Arm Assembly F/L	Chassis Hole	A-2	T
	7 Lever Assembly S/W	Chassis Hole, 1 hook	A-2	T
	8 Motor Assembly L/D	1 screw	A-3	T
	9 Gear Wheel	2 hooks	A-3	T
	10 Arm Assembly Cleaner	Chassis Embossing	A-3	T
	11 Head F/E	Chassis Embossing	A-3	T
	12 Base Assembly A/C Head	1 screw	A-3	T
2,3	13 Brake Assembly T	1 hook	A-4	T
2,3	14 Arm Assembly Tension	1 hook	A-4	T
2,3,13,14	15 Reel S / Reel T	Shaft	A-4	T
	16 Base Assembly P4	Chassis Embossing	A-5	T
	17 Opener Lid	Chassis Embossing	A-5	T
17	18 Arm Assembly Pinch	Shaft	A-5	T
17	19 Arm T/up	1 hook	A-5	T
	20 Supporter, capstan	Chassis Hole	A-6	B
17,18	21 Belt Capstan/Motor Capstar	3 screws	A-6	B
	22 Lever F/R	Locking Tab	A-6	B
21, 22	23 Clutch Assembly D37	Washer	A-6	B
	24 Gear Drive/Gear Cam	Washer/Hook	A-7	B
	25 Gear Sector	Hook	A-7	B
21	26 Brake Assembly Capstan	Chassis Hole	A-7	B
21,22,23, 24,25,26	27 Plate Slider	Chassis Guide	A-7	B
21,22,23, 24,25,26,27	28 Lever Tension	1 Hook	A7	B
21,22,23, 24,25,26,27	29 Lever Spring	1 Hook	A-7	B
21,22,23, 24,25,26,27	30 Lever Brake	1 Hook	A-7	B
25	31 Gear Assembly P2/ Gear Assembly P3	Bass	A-8	B
2, 3, 14, 25, 31	32 Base Assembly P2 /Base Assembly P3	6 Chasses	A-8	B
25, 31	33 Base Loading	3 Hooks	A-8	B
2,3,14	34 Base Tension	Chassis Embossing	A-9	T
	35 Arm Assembly Idler Jog	Locking Tab	A-9	T

T:Top, B:Bottom

NOTE : Assembly order is a reverse of disassembly order.

- (1) For assembly, check the assembly mode is accurate.
- (2) Parts firstly disassembled indicate parts firstly disassembled in disassembly of related parts.

DISASSEMBLY AND ASSEMBLY OF DECK MECHANISM

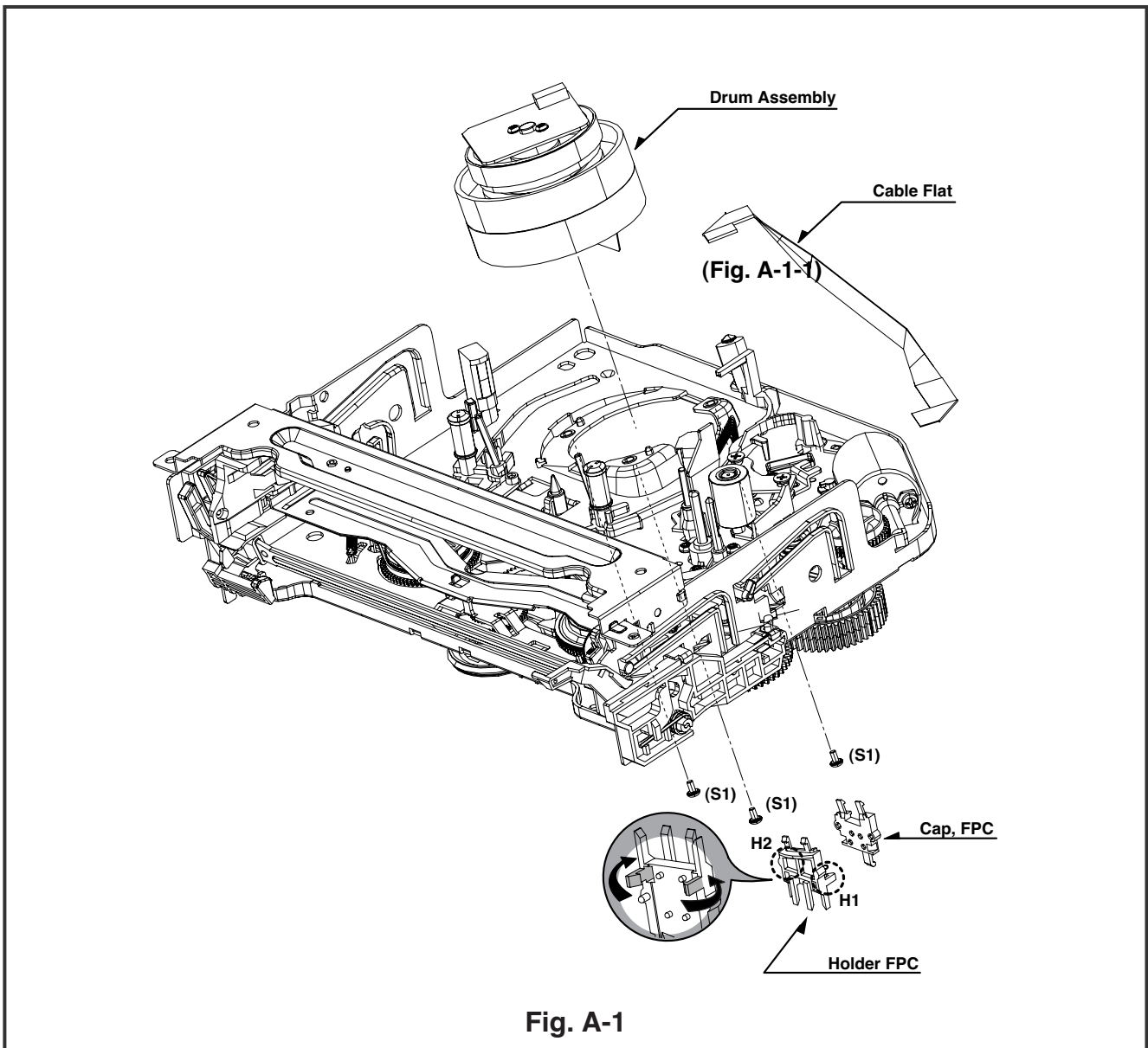
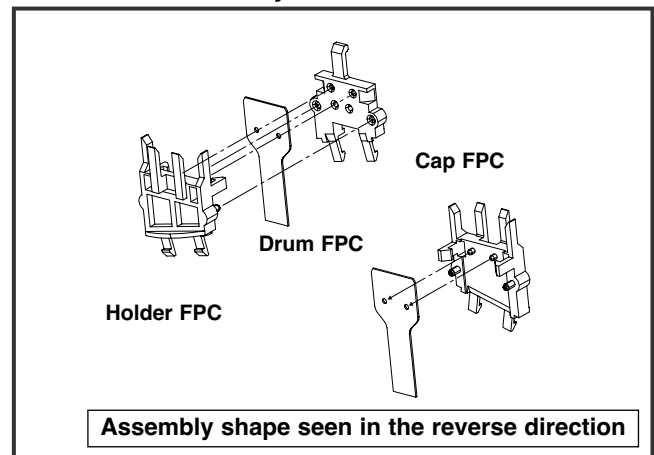

Fig. A-1

1. Disassembly of Drum Assembly (Figure A-1)

- 1) Separate cable flat from the Drum FPC and the Capstan Motor.
- 2) Release 3 screws (S1) on the bottom side of the chassis, and separate the drum assembly.
- 3) Release the hooks (H1, H2) and separate both the holder FPC and the Cap FPC (disassemble if necessary).

Cautions in assembly of FPC



DISASSEMBLY AND ASSEMBLY OF DECK MECHANISM

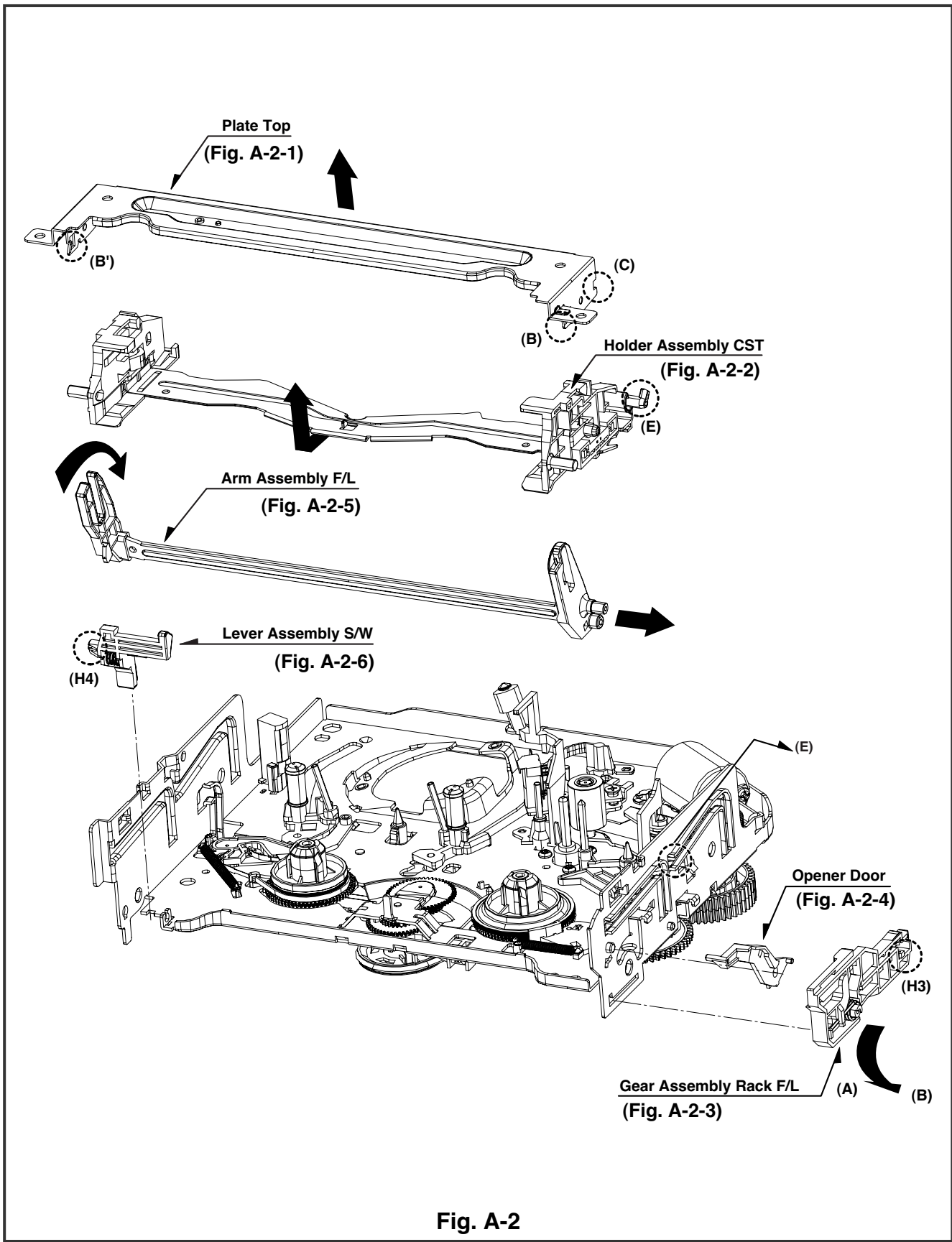

Fig. A-2

DISASSEMBLY AND ASSEMBLY OF DECK MECHANISM

2. Disassembly of Plate Top (Fig. A-2-1)

- 1) Separate the right part while leaning back the (B) part of the plate top toward the arrow direction.
- 2) Separate the left part while leaning back the (B') part of the plate top toward the arrow direction.
(Tool used: Tool such as (-) driver, auger, etc with pointed or flat end)

CAUTIONS

Assemble while pressing the (C), (C') part after corresponding them as in drawing.

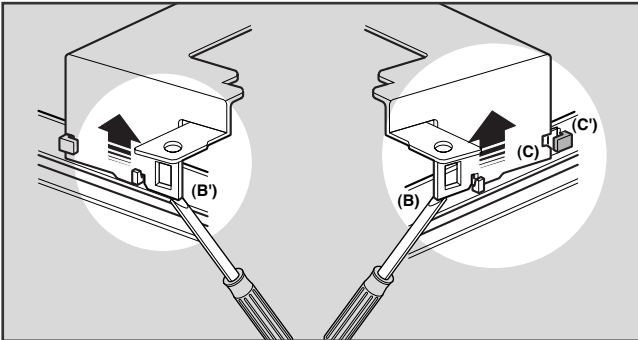

3. Holder Assembly CST (Fig. A-2-2)

- 1) Firstly separate the left part from the groove on the (D) part of chassis while moving the holder assembly CST toward the arrow direction.

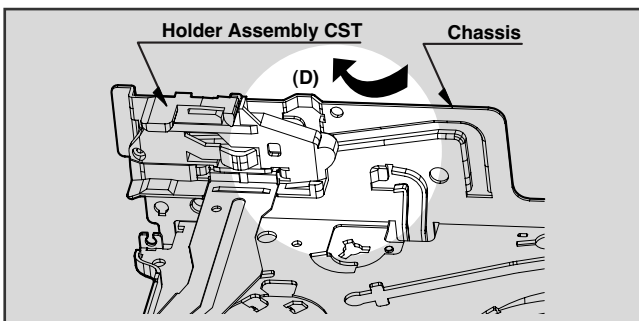

- 2) Separate the right part from each groove of chassis

CAUTIONS

Assemble by inserting the left part after firstly inserting the (E) part of the holder assembly CST into the groove on the (E') part of chassis.

4. Disassembly of Gear Assembly Rack F/L (Fig. A-2-3)

- 1) Separate the hook (H3) while leaning ahead the hook (3) after moving the gear assembly rack F/L toward the arrow (A) direction.
- 2) Separate the gear assembly rack F/L toward the arrow (B) direction.

CAUTIONS

For the assembly, correspond the gear part of gear assembly rack F/L to the gear drive.

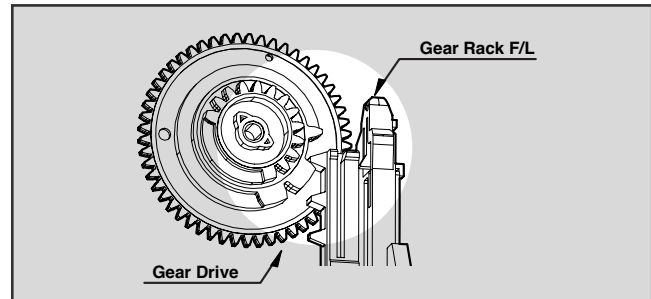

5. Opener Door (Fig. A-2-4)

- 1) Separate the opener door ahead from the guide hole of chassis while turning it clockwise.

6. Arm Assembly F/L (Fig. A-2-5)

- 1) Firstly separate the left part of the arm assembly F/L from the groove of chassis while pushing the arm assembly F/L toward the arrow direction.
- 2) Separate the right part from the groove of chassis.

7. Lever Assembly S/W (Fig. A-2-6)

- 1) Separate the lever assembly S/W while pushing it toward the arrow direction after removing the hook (4) on the left side of chassis.

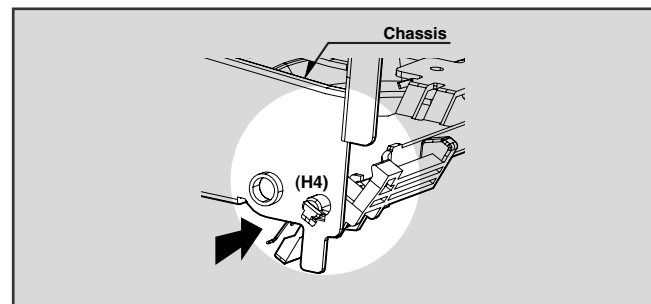

DISASSEMBLY AND ASSEMBLY OF DECK MECHANISM

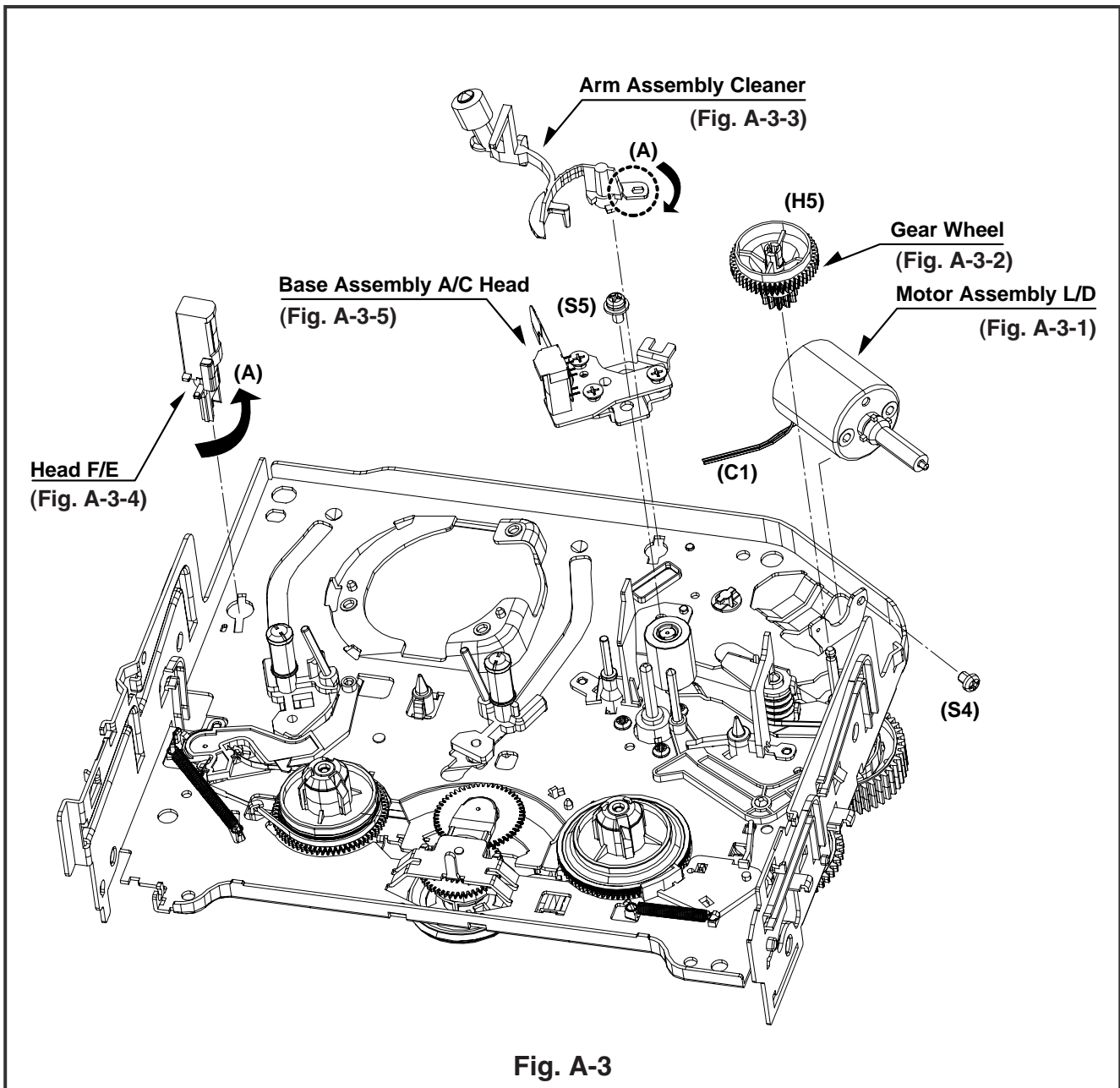

Fig. A-3

8. Motor Assembly L/D (Fig. A-3-1)

- 1) Take the connector (C1) connected to the Capstan motor PCB out.
- 2) Remove a screw (S4) of the chassis (S4) and step backward, and disassemble it while holding it up.

9. Gear Wheel (Fig. A-3-2)

- 1) Release the hook (H5) of the gear wheel and disassemble it upward.

10. Arm Assembly Cleaner (Fig. A-3-3)

- 1) Separate the (A) part of Fig. A-3-1 from the embossing of chassis, and hold it up while turning it anti-clockwise.

11. Head F/E (Fig. A-3-4)

- 1) Separate the (A) part of the head F/E from the embossing of chassis, and hold it up while turning it anti-clockwise.

12. Base Assembly A/C Head (Fig. A-3-5)

- 1) Release a screw (S5) and disassemble while holding it up.

DISASSEMBLY AND ASSEMBLY OF DECK MECHANISM

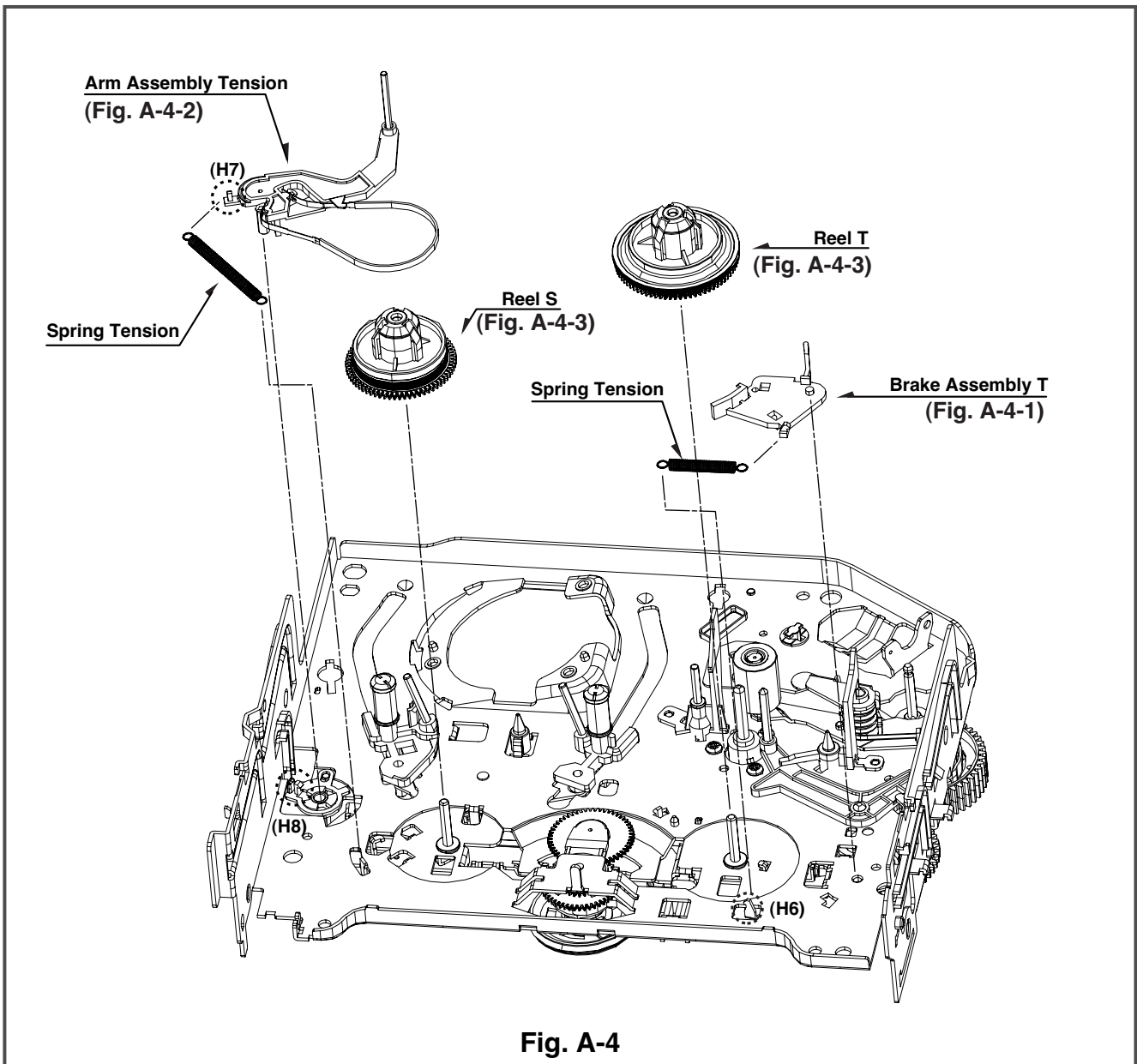

Fig. A-4

13. Brake Assembly T (Fig. A-4-1)

- 1) Release the spring tension from the lever spring hook (H6).
- 2) Disassemble the brake assembly T while holding it upward.

14. Arm Assembly Tension (Fig. A-4-2)

- 1) Release the spring tension the hook (H7) from the arm assembly tension.
- 2) After releasing the hook (H8) of the base tension, separate it while holding it up.

CAUTIONS

Spring used for both brake assembly T and arm assembly tension is used (2EA used).

15. Reel S/Reel T (Fig. A-4-3)

- 1) Disassemble the reel S/ reel T while holding it up (comparison between Reel S and Reel T)

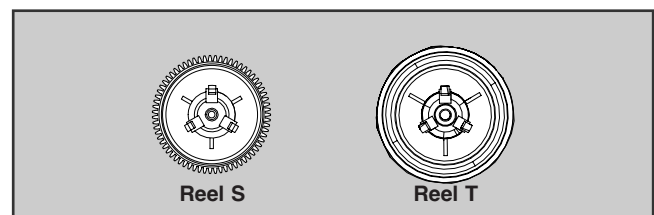

DISASSEMBLY AND ASSEMBLY OF DECK MECHANISM

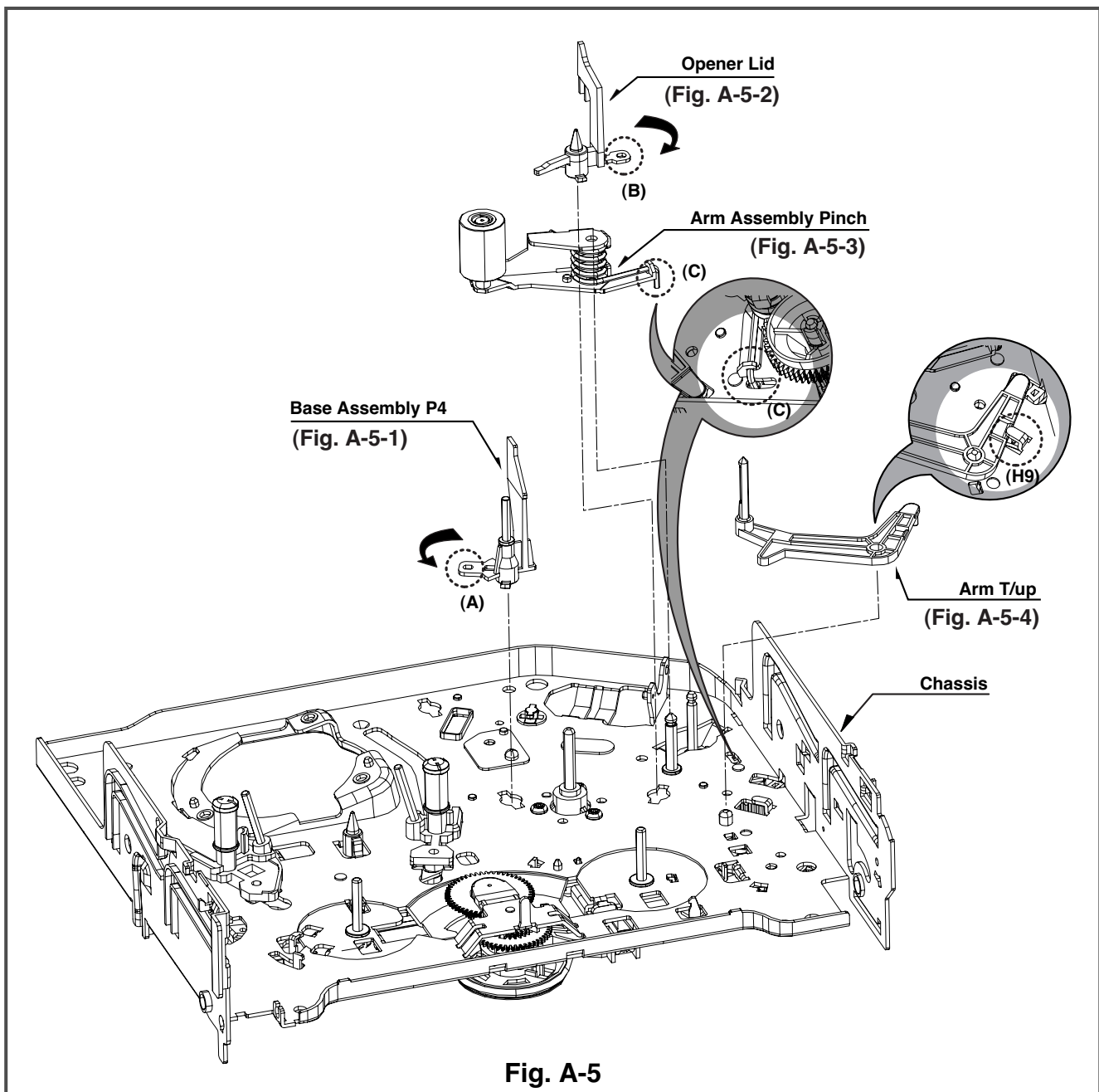

Fig. A-5

16. Base Assembly P4 (Fig. A-5-1)

- 1) Release the (A) part of the base assembly P4 from the embossing of chassis.
- 2) Hold the base assembly P4 up while turning it anti-clockwise.

17. Opener Lid (Fig. A-5-2)

- 1) Release the (B) part of the opener lid from the embossing of chassis.
- 2) Disassemble the opener lid upward while turning it anti-clockwise.

18. Arm Assembly Pinch (Fig. A-5-3)

- 1) Hold the arm assembly pinch up.

19. Arm T/up (Fig. A-5-4)

- 1) Turn the arm T/up to release the anchor jaw (H9) part of chassis and then hold it upward.

CAUTIONS

For the assembly, check the (C) part of the arm assembly pinch is assembled as in drawing.

- REVERSE THE MECHANISM.

DISASSEMBLY AND ASSEMBLY OF DECK MECHANISM

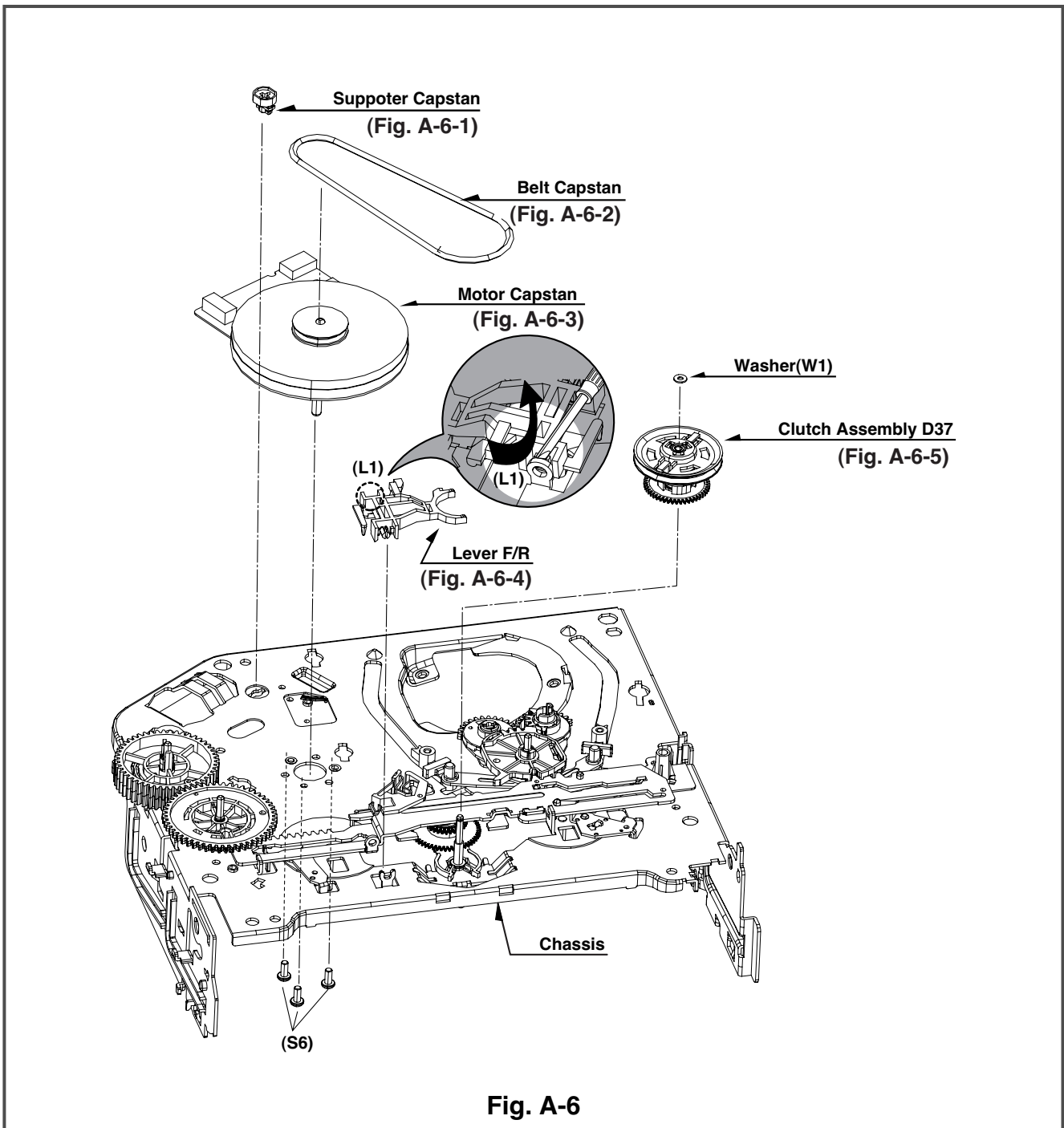

Fig. A-6

20. Supporter, Capstan (Fig. A-6-1)

- 1) Turn the supporter and Capstan by 90 deg. clockwise with a driver for disassembly.

21. Belt Capstan (Fig. A-6-2) / Motor Capstan (Fig. A-6-3)

- 1) Separate the belt Capstan.
- 2) Undo 3 screws (S6) on the bottom side of chassis and disassemble it upward.

22. Lever F/R (Fig. A-6-4)

- 1) Release the locking tab (L1) and then disassemble it upward.

23. Clutch Assembly D37 (Fig. A-6-5)

- 1) Remove the washer (W1) and then disassemble it upward.

DISASSEMBLY AND ASSEMBLY OF DECK MECHANISM

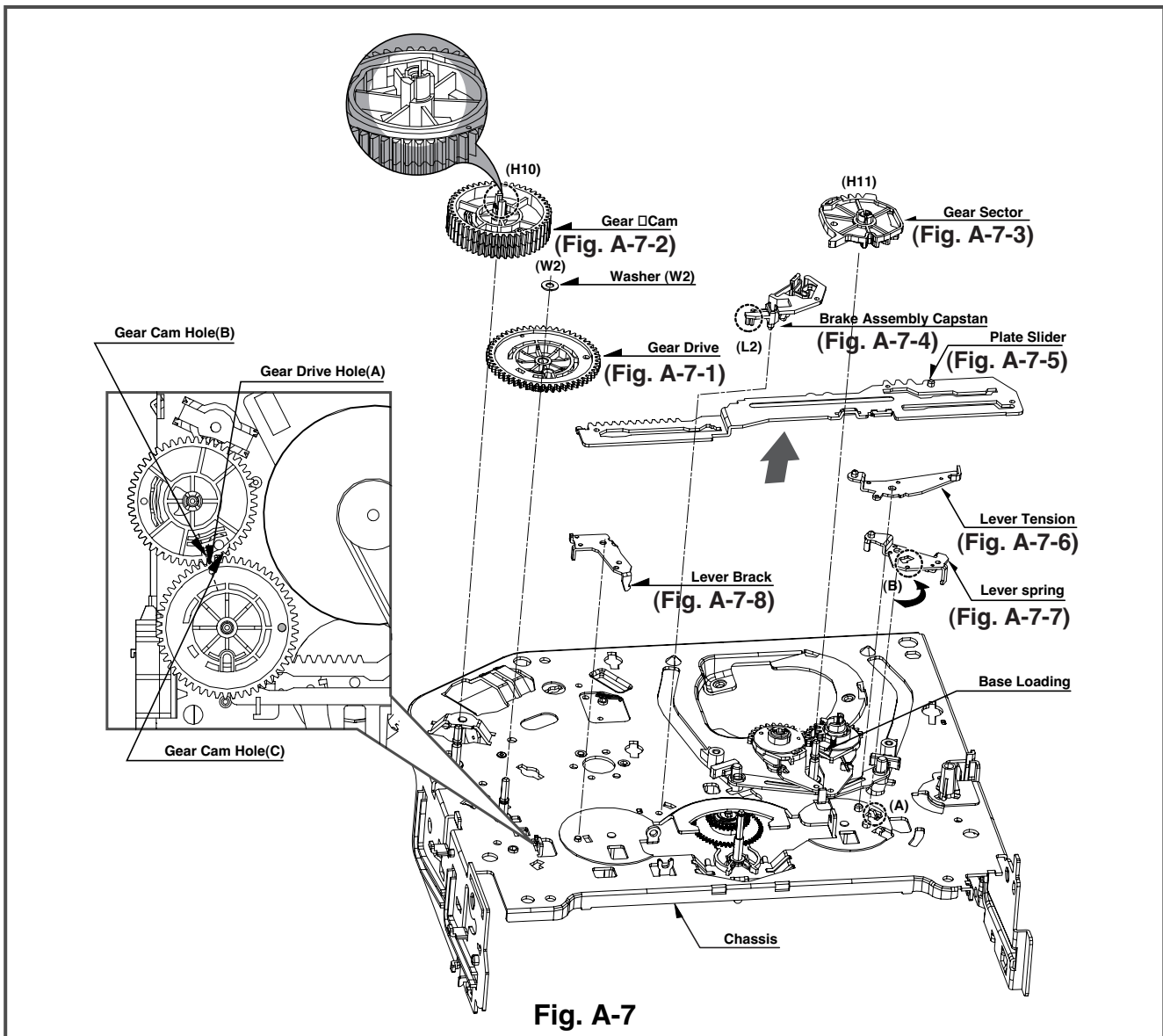

Fig. A-7

24. Gear Drive (Fig. A-7-1)/ Gear Cam (Fig. A-7-2)

- 1) Remove the washer (W2) and then disassemble the gear drive.
- 2) Release the hook (H10) of the gear cam and then disassemble it upward.

CAUTIONS

For the assembly, adjust both the gear driver hole (A) and the gear cam hole (B) straightly and then correspond the gear cam hole (C) to the chassis hole.

25. Gear Sector (Fig. A-7-3)

- 1) Release the hook (H11) of the gear sector and then hold the gear sector upward.

26. Brake Assembly Capstan (Fig. A-7-4)

- 1) Release the locking tab (L2) on the bottom side of the plate slider and then disassemble it upward.

27. Plate Slider (Fig. A-7-5)

- 1) Disassemble the plate slider while holding it up.

28. Lever Tension (Fig. A-7-6)

- 1) Release the lever tension from the guide (A) of chassis while turning it anti-clockwise.
- 2) Disassemble the lever tension while holding it up.

29. Lever Spring (Fig. A-7-7)

- 1) Release the (B) part of the lever spring from the guide (A) of chassis while turning it anti-clockwise.
- 2) Disassemble the lever tension while holding it up.

30. Lever Brake (Fig. A-7-8)

- 1) Disassemble the lever brake while holding it up.

DECK MECHANISM DISASSEMBLY

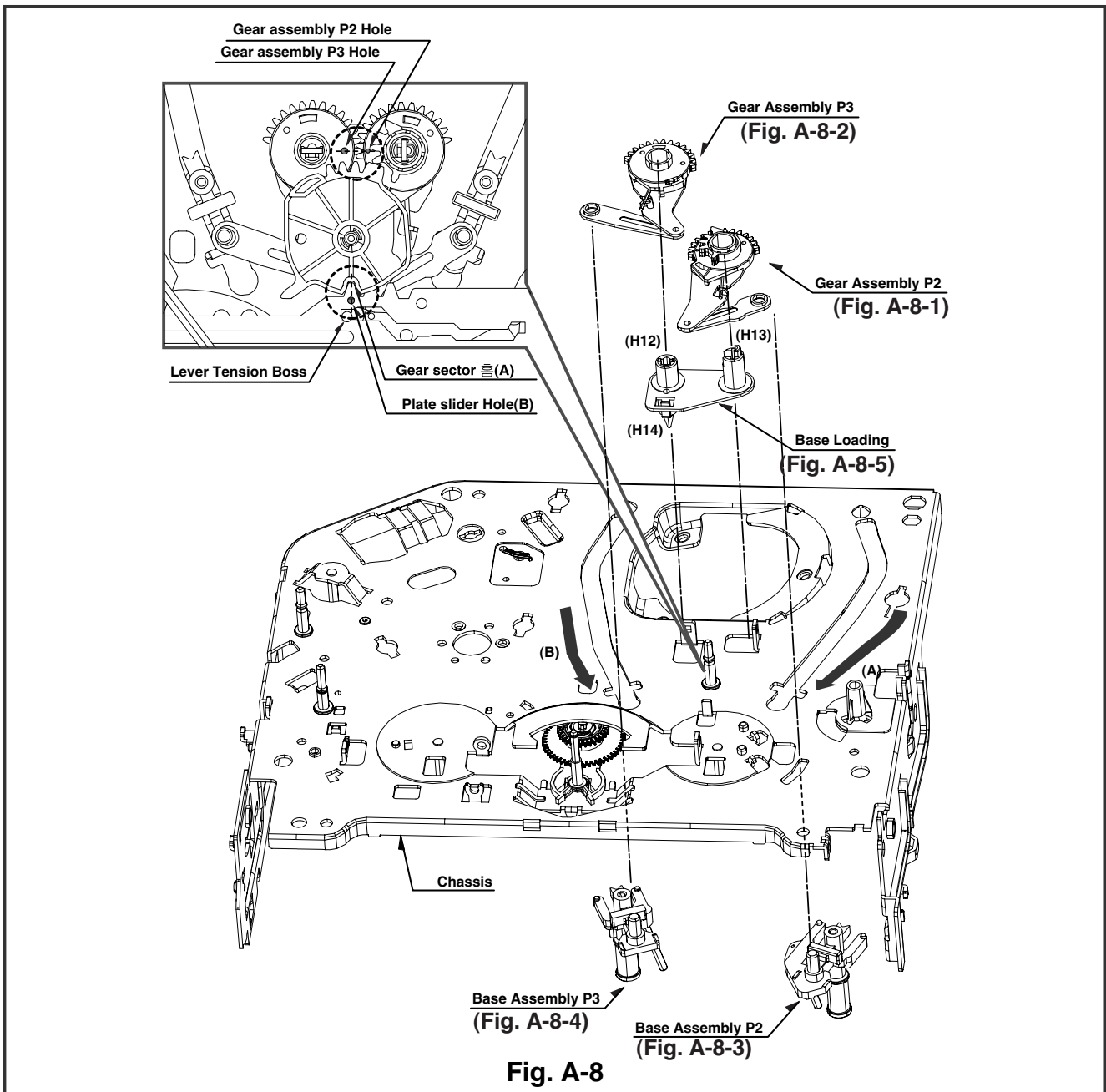

Fig. A-8

31. Gear Assembly P2 (Fig. A-8-1)/ Gear Assembly P3 (Fig. A-8-2)

- 1) Hold the gear assembly P2 upward.
- 2) Hold the gear assembly P3 upward.

CAUTIONS

For the assembly, check the holes of both the gear assembly P2 and the P3 are adjusted straightly, and then correspond the gear section groove (A) to the plate slider hole (B).

32. Base Assembly P2 (Fig. A-8-3)/ Base Assembly P3 (Fig. A-8-4)

- 1) Disassemble the base assembly P2 downward while moving it toward the arrow (A) direction along with the guide hole of chassis.
- 2) Disassemble the base assembly P2 downward while moving it toward the arrow (B) direction along with the guide hole of chassis.

33. Base Loading (Fig. A-8-5)

- 1) Release 3 hooks (H12, 13, 14) of the base loading, and then disassemble them upward.
- Reverse the mechanism.

DISASSEMBLY AND ASSEMBLY OF DECK MECHANISM

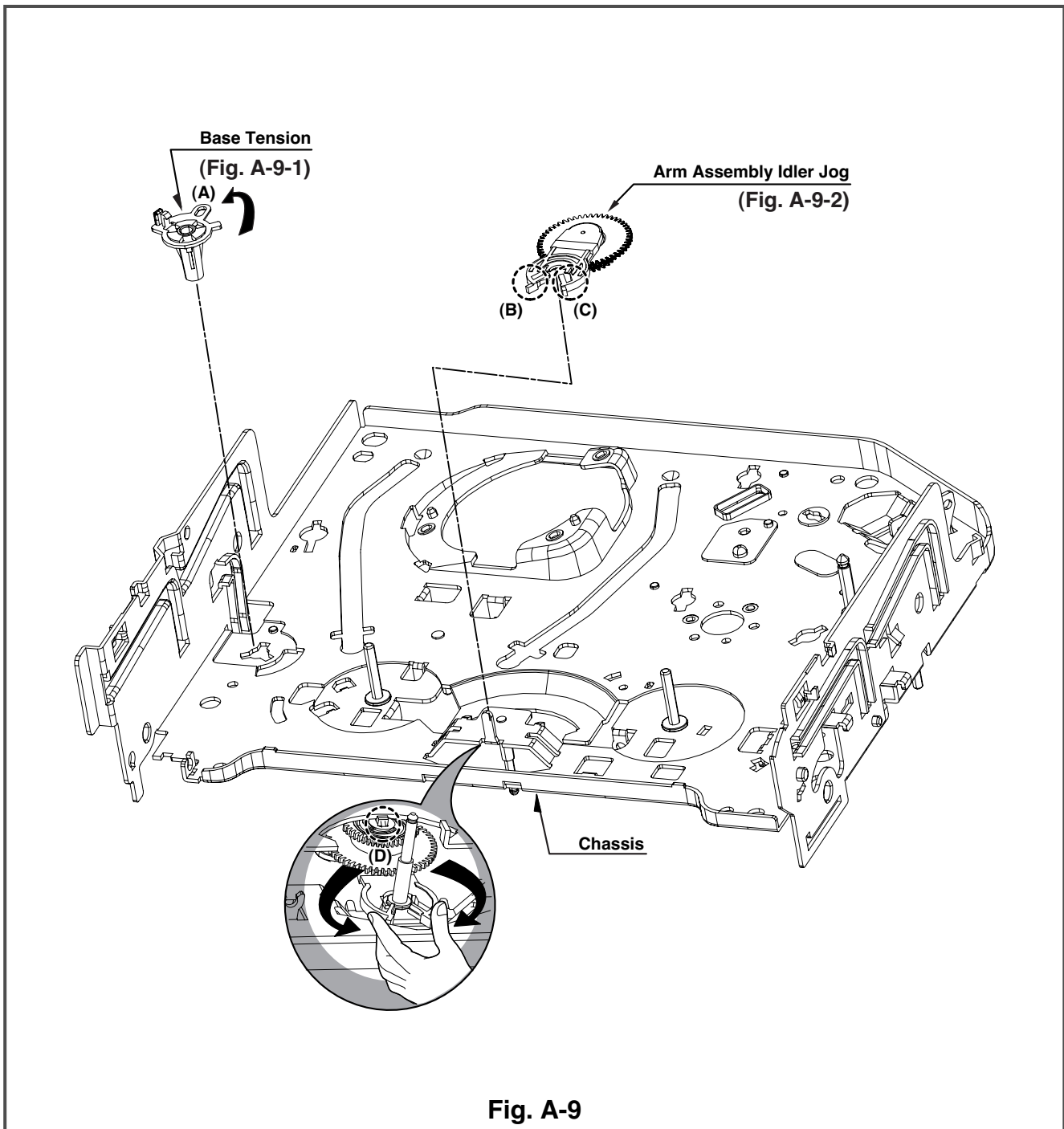

Fig. A-9

34. Base Tension (Fig. A-9-1)

- 1) Release the (A) part of the base tension from the embossing of chassis.
- 2) Hold the base tension upward while turning it anti-clockwise.

35. Arm assembly Idler Jog (Fig. A-9-2)

- 1) Push both (B), (C) parts in Fig. A-9-2 toward the arrow direction.
- 2) Disassemble the arm assembly idler upward.

CAUTIONS

Take care to ensure that the (D) part in the drawing is not hung to chassis in disassembly.

DECK MECHANISM ADJUSTMENT

• Fixtures and Tools for Service

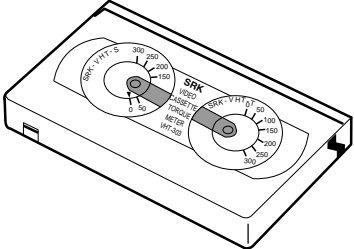
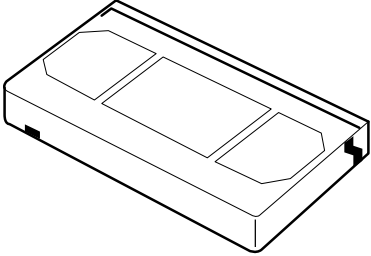
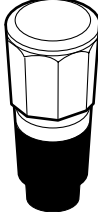
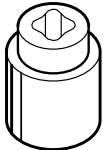
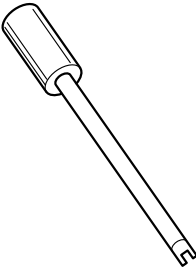
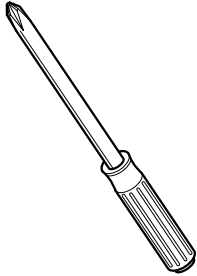
<p>1. Cassette Torque Meter SRK-VHT-303(Not SVC part) Part No:D00-D006</p>  A rectangular cassette torque meter with two circular gauges on top. Each gauge has a scale from 0 to 300 and a needle. The text 'SRK VHT-303 TORQUE METER' is visible on the device.	<p>2. Alignment tape Part No NTSC:DTN-0001 PAL:DTN-0002</p>  A rectangular alignment tape with a central rectangular cutout and two smaller rectangular cutouts on either side.	<p>3. Torque gauge 600g.Cm ATG Part No:D00-D002</p>  A cylindrical torque gauge with a hexagonal top section and a black base.
<p>4. Torque gauge adaptor Part No:D09-R001</p>  A cylindrical torque gauge adaptor with a central opening and a small notch on top.	<p>5. Post height adjusting driver Part No:DTL-0005</p>  A long, thin metal driver with a cylindrical handle and a small hook-like tip.	<p>6. + Type driver (ø5)</p>  A standard Phillips (+) type screwdriver with a textured handle and a pointed tip.

DECK MECHANISM ADJUSTMENT

1. Mechanism Assembly Mode Check

Purpose of adjustment : To make tools normally operate by positioning tools accurately.

Fixtures and tools used	VCR (VCP) status	Checking Position
• Blank Tape (empty tape)	• Eject Mode (with cassette withdrawn)	• Mechanism and Mode Switch
<p>1) Turn the VCR on and take the tape out by pressing the eject button.</p> <p>2) Separate both top cover and plate top, and check both the hole (A) of gear cam and the hole (A') of chassis correspond (Fig. C-2).</p> <p>3) If it is done as in the paragraph 2): Turn the gear cam after mantling the motor assembly L/D.</p> <p>4) Undo the screw fixing the deck and the main frame, and separate the deck assembly. Check both the hole (A) of gear cam and the hole (A') of chassis correspond (Fig. C-1).</p> <p>5) Check the mode S/W on the main P.C. board locates at a proper position as in (B) of the Fig. (C-1).</p> <p>6) Connect the deck to the main P.C. board and perform all types of test.</p>		

CHECK DIAGRAM

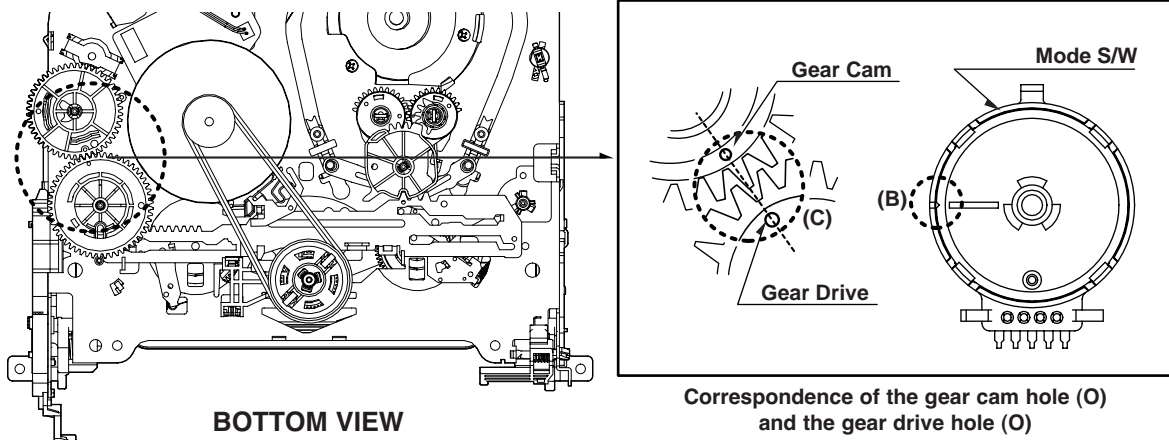

Fig. C-1

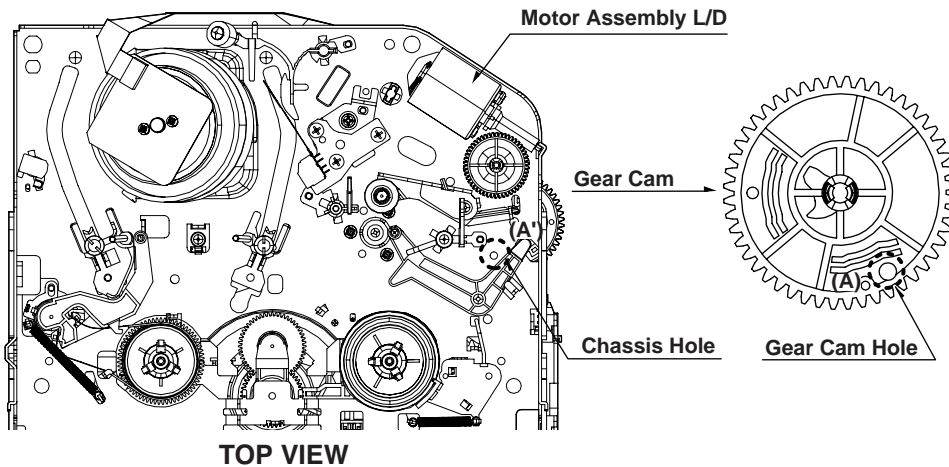

Fig. C-2

DECK MECHANISM ADJUSTMENT

2. Previous Preparation for Deck Adjustment

(Preparation to load the VCR (VCP) with cassette tape not inserted)

- 1) Take the power cord from the consent.
- 2) Separate the top cover and the plate assembly top.
- 3) Insert the power cord into again.
- 4) Turn the VCR (VCP) on and load the cassette while pushing the lever stopper of the holder assembly CST backward. In this case, clog both holes on the housing rail part of chassis to prevent detection of the end sensor.

If doing so, proceeding to the stop mode is done. In this status, input signals of all modes can be received. However, operation of the Rewind and the Review is impossible since the take-up reel remains at stop status and so cannot detect the reel pulse (however, possible for several seconds).

3. Torque Measuring

Purpose of Measuring : To measure and check the reel torque on the take-up part and the supply part that performs basic operation of the VCR (VCP) for smoothly forwarding the tape.
Measure and check followings when the tape is not smoothly wound or the tape velocity is abnormally proceeded:

Fixtures and tools used	VCR (VCP) status	Measuring method
<ul style="list-style-type: none"> • Torque Gauge (600 g.cm ATG) • Torque Gauge Adaptor • Cassette Torque Meter SRK-VHT-303 	<ul style="list-style-type: none"> • Play (FF) or Review (REW) Mode 	<ul style="list-style-type: none"> • Try to operate the VCR (VCP) per mode with the tape not inserted (See '2. Prior Preparation for Deck Adjustment). • Measure after adhering and fixing the torque gauge adaptor to the torque gauge (Fig. C-3-1) • Read scale of the supply or take-up part of the cassette torque meter (Fig. C-3-2).

Item	Mode	Instruments	Reel Measured	Measuring Value
Fast forward Torque	Fast Forward	Torque Gauge	Take-Up Reel	More than 400g°cm
Rewind Torque	Rewind	Torque Gauge	Supply Reel	More than 400g°cm
Play Take-Up Torque	Play	VHT-303	Take-Up Reel	40~100g°cm
Review Torque	Review	VHT-303	Supply Reel	120~210g°cm

NOTE

Adhere the torque gauge adaptor to the torque gauge for measuring the value.

• Torque Gauge (600g.cm ATG)

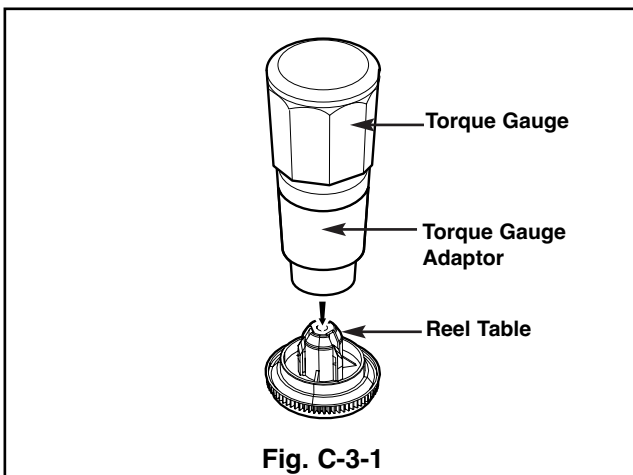

• Cassette Torque Meter (SRK-VHT-303)

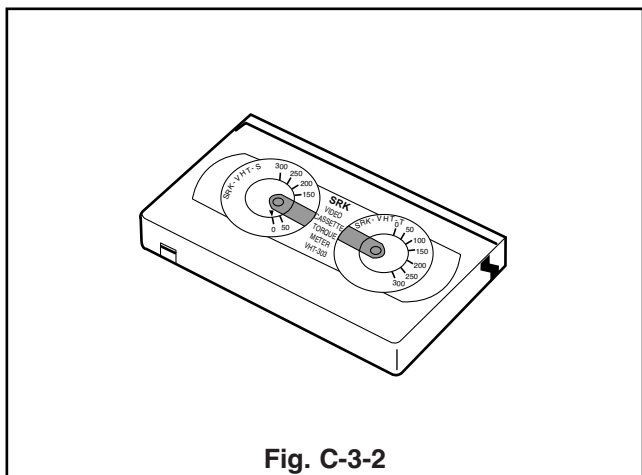

DECK MECHANISM ADJUSTMENT

4. Guide Roller Height Adjustment

Purpose of adjustment : To ensure that the bottom surface of the tape can travel along with the tape lead line of the lower drum by constantly and adjusting and maintaining the height of the tape.

4-1. Prior Adjustment

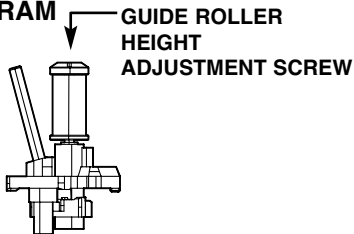
Fixtures and tools used	VCR (VCP) status	Adjustment position
<ul style="list-style-type: none"> • Post Height Adjusting Driver 	<ul style="list-style-type: none"> • Play or Review Mode 	<ul style="list-style-type: none"> • The guide roller height adjusting screw on the supply guide roller and the take-up guide roller
Adjustment Procedure 1) Travel the tape and check the bottom surface of the tape travels along with the guide line of the lower drum. 2) If the tape travels toward the lower part of guide line on the lower drum, turn the guide roller height adjusting screw to the left 3) If it travels to the upper part, turn it to the right. 4) Adjust the height of the guide roller to ensure that the tape is guided on the guide line of the lower drum at the inlet/outlet of the drum. (Fig. C-4-1)		ADJUSTMENT DIAGRAM  Fig. C-4-1

4-2. Fine Adjustment

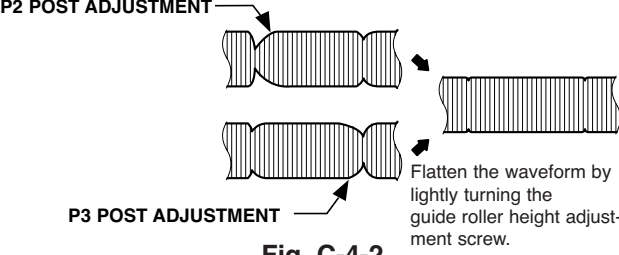
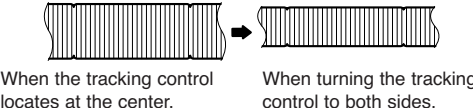
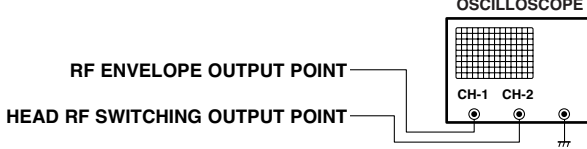
Fixtures and tools used	Measuring tools and connection position	VCR (VCP) status	Adjustment position
<ul style="list-style-type: none"> • Oscilloscope • Standard test tape • Post height adjusting driver 	<ul style="list-style-type: none"> • CH-1: PB RF Envelope • CH-2: NTSC : SW 30Hz PAL : SW 25Hz • Head switching output point • RF Envelope output point 	<ul style="list-style-type: none"> • Play the standard test tape. 	<ul style="list-style-type: none"> • Guide roller height adjusting screw
1) Play the standard test tape after connecting the probe of oscilloscope to the RF envelope output point and the head switching output point. 2) Tracking control (playback) : Locate it at the center (Set the RF output to the maximum value via the tracking control when such adjustment is completed after the drum assembly is replaced.) 3) Height adjusting screw: Flatten the RF waveform. (Fig. C-4-2) 4) Move the tracking control (playback) to the right/left. (Fig. C-4-3) 5) Check the start and the end of the RF output reduction width are constant.		Waveform  Fig. C-4-2	
		 Fig. C-4-3	
CAUTIONS There must exist no crumpling and folding of the tape due to excess adjustment or insufficient adjustment.		Connection Diagram 	

DECK MECHANISM ADJUSTMENT

5. Audio/Control (A/C) Head Adjustment

Purpose of adjustment : To ensure that audio and control signals can be recorded and played according to the contract tract by constantly maintaining distance between tape and head, and tape tension between the P3 post and the P4 post.

5-1. Prior Adjustment (performed only when no audio output appears in play of the standard test tape)

Fixtures and tools used	VCR (VCP) status	Adjustment position
<ul style="list-style-type: none"> Blank Tape (Empty Tape) Driver (+) Type $\phi 5$ 	<ul style="list-style-type: none"> Play the blank tape (empty tape). 	<ul style="list-style-type: none"> Tilt adjusting screw (C) Height adjusting screw (B) Azimuth adjusting screw (A)

Adjustment Procedure/Adjustment Diagrams

- Basically use the A/C head assembly adjusted as in SPEC.
- Check there is crumpling and folding of the tape around the A/C head. If it is, Turn and adjust the tilt adjusting screw to ensure that the tape corresponds to the bottom guide of the P4, and recheck the tape path after proceeding play for 4-5 seconds.

- Where the tape bottom is not equal to Fig. C-5-3, Adjust the height by using the height adjusting screw (B) and then readjust it by using the tilt adjusting screw (C).

CAUTIONS

Always check the height of the A/C head since most ideal height of A/C head can be obtained when the bottom part of the tape is away 0.2 ~ 0.25mm from the bottom part of the A/C head.

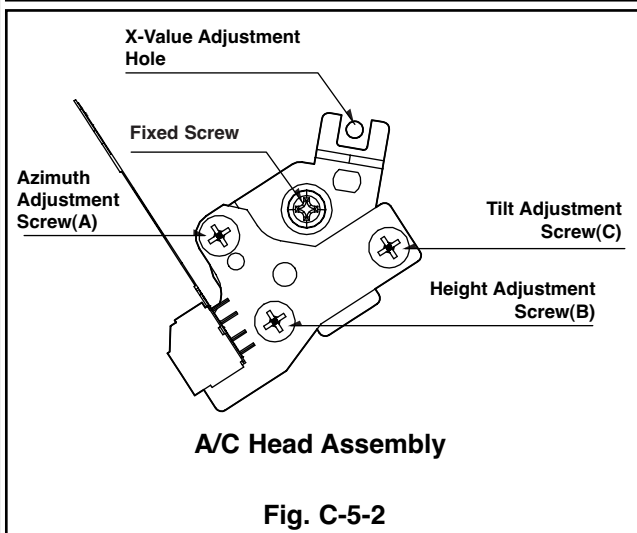
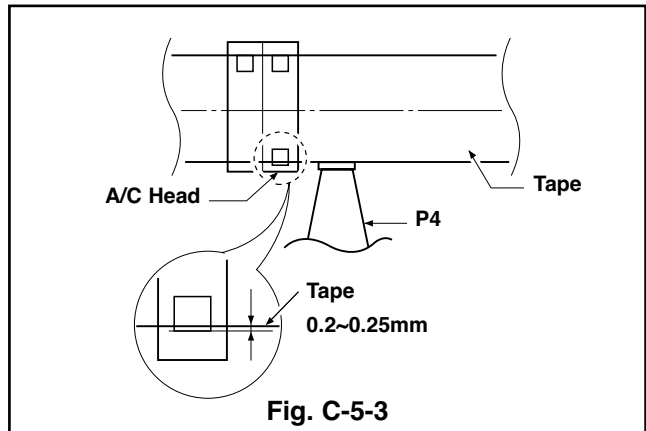
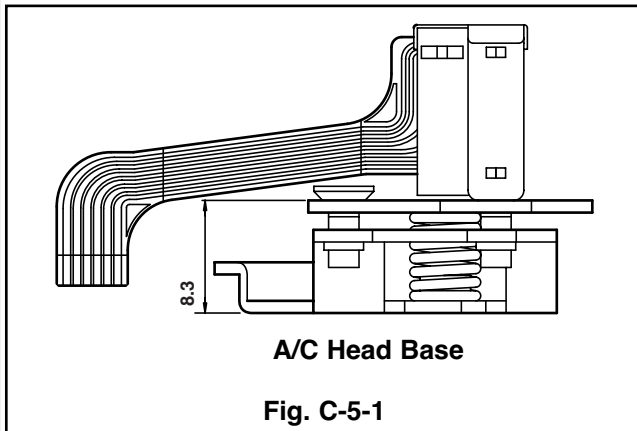

DECK MECHANISM ADJUSTMENT

5-2. Tape Path Check between Pinch Roller and Take up Guide (Check in the Rev Mode)

- 1) Check the tape pass status between the pinch roller and the take-up guide.(Check there is crumpling of the tape pass and folding of the take-up guide.)
 - (1) When holding of the take-up guide bottom occurs
Turn the tilt adjusting screw (C) clockwise and travel it stably to ensure there is no crumbling or folding of the tape.
 - (2) When holding of the take-up guide top occurs
Turn the tilt adjusting screw (C) anti-clockwise and

travel it stably to ensure there is no crumbling or folding of the tape.

- 2) Check there is folding of the tape at the bottom or top of the take-up guide in cutting-off the REV mode

CAUTIONS

If the RF waveform is changed after adjusting the A/C head, perform fine adjustment to ensure the RF waveform is flattened.

5-3. Fine Adjustment (Azimuth Adjustment)

Fixtures and tools used	Connection position	VCR (VCP) status	Adjustment position
<ul style="list-style-type: none"> • Oscilloscope • Standard test tape (only for SP) • Driver (+) Type Ø 4 	<ul style="list-style-type: none"> • Audio Output Jack 	<ul style="list-style-type: none"> • Play the standard test Tape, 1KHz, 7KHz. 	<ul style="list-style-type: none"> • Azimuth Adjusting Screw (A) • Height Adjusting Screw (B)
Adjustment Procedure <ol style="list-style-type: none"> 1) Connect the probe of Oscilloscope to the audio output jack. 2) Ensure that Audio 1KHz, 7KHz output is flattened at the maximization point by adjusting the Azimuth adjusting screw (A). 		<p style="text-align: center;">Fig. C-5-4</p>	

6. X-distance Adjustment

Purpose of adjustment : To maintain compatibility with other VCR (VCP).			
Fixtures and tools used	Connection position	VCR (VCP) status	Adjustment position
<ul style="list-style-type: none"> • Oscilloscope • Standard test tape (only for SP) • Driver (+) Type Ø 4 	<ul style="list-style-type: none"> • CH-1: PB RF Envelope • CH-2: NTSC ; SW 30Hz PAL:SW 25Hz • Head switching output point • RF Envelope output point 	<ul style="list-style-type: none"> • Play the standard test tape. 	
Adjustment Procedure <ol style="list-style-type: none"> 1) After releasing the auto tracking, lightly turn the fixing screw. Turn the (+) type driver (Ø 3 ~ Ø 4) on the X-distance adjusting hole to the right or left. Adjust the RF envelope level to the maximum point and then fix the fixing screws. 2) For the 31mm head, adjust it with the SP tape recorded in the width of 31mm since the head travels on the tape track only for SP with the width of 58mm. 	Connection Diagram <p style="text-align: center;">Fig. C-6</p>		

DECK MECHANISM ADJUSTMENT

7. Adjustment after Drum Assembly (Video Heads)

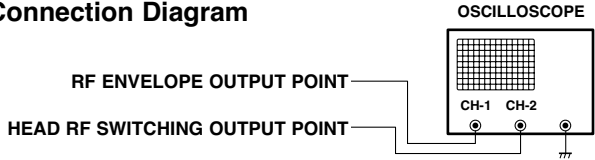
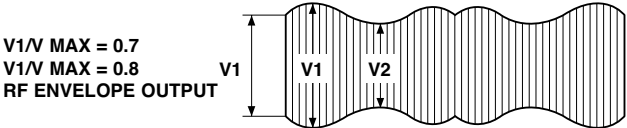
Purpose of adjustment : To adjust and stabilize the height change, X-distance change, etc depending on the guide roller after assembling the drum.			
Fixtures and tools used	Connection position	VCR (VCP) status	Adjustment position
<ul style="list-style-type: none"> • Oscilloscope • Standard test tape (only for SP) • Post Height Adjusting Driver • Driver (+) Type Ø 5 	<ul style="list-style-type: none"> • CH-1: PB RF Envelope • CH-2: NTSC : SW 30Hz PAL:SW 25Hz • Head switching output point • RF Envelope output point 	<ul style="list-style-type: none"> • Play the blank tape. • Play the standard test tape. 	<ul style="list-style-type: none"> • Fine adjustment of guide roller • Switching Point • Tracking Preset • X-distance
Checking/Adjustment Procedure <ol style="list-style-type: none"> 1) Play the blank tape (empty tape) and check whether the guide roller crumbles or wrinkles the tape and adjust it if necessary. 2) Check that the RF envelope output waveform is flat, and adjust the height of the guide roller while playing the standard test tape. 3) Adjust the switching point. 4) Check the RF envelope output is the maximum when the tracking control locates at the center. If not maximum, set up to ensure that RF envelope output becomes the maximum by turning the (+) type driver (Ø 3 ~ Ø 4) on the base A/C groove. 		Connection Diagram  Waveform  <p>V1/V MAX = 0.7 V1/V MAX = 0.8 RF ENVELOPE OUTPUT</p>	

8. Check of Traveling Device after Deck Assembly

8-1. Audio, RF Normalization Time (Locking Time) Check in Play after CUE or REV

Fixtures and tools used	Measuring standard	Connection position	VCR (VCP) status
<ul style="list-style-type: none"> • Oscilloscope • 6H 3KHz Color Bar Standard Test tape • Stop Watch 	<ul style="list-style-type: none"> • RF Locking Time: Within 5 seconds • Audio Locking Time : Within 10 seconds 	<ul style="list-style-type: none"> • CH-1: PB RF Envelope • CH-2: Audio output • RF Envelope output point • Audio output jack 	<ul style="list-style-type: none"> • Play the 6H 3KHz Color Bar Standard Test tape.
Checking Procedure <ol style="list-style-type: none"> 1) Check that locking time of the RF and Audio waveform is fallen within the measuring standard in conversion of the play mode from the CUE or the REV mode. 		<ol style="list-style-type: none"> 2) Readjust the paragraph 5 and 6 if it deviates from the standard. 	

8-2. Check of Tape Curl and Jam Status

Fixtures and tools used	Fixtures and tools used	Fixtures and tools used
<ul style="list-style-type: none"> • T-160 Tape • T-120 Tape 	<ul style="list-style-type: none"> • There must be no jam or curl at the first, middle and end position of tape. 	<ul style="list-style-type: none"> • Travel the tape at the position of its first and end.
Checking Procedure <ol style="list-style-type: none"> 1) Check there is no abnormality of every traveling post status. 2) There must be no abnormal operation of the counter in 		<ol style="list-style-type: none"> occurrence of folding of the bottom tape. There must be not abnormality of audio signal in damage of the top tape. 3) If there is abnormality, readjust the adjustment paragraph 4 and 5.

PROTECTION, MAINTENANCE AND CHECK OF VIDEO FUNCTION

1. Checking Points prior to Repair

Following abnormal phenomena may be repaired by removal of foreign materials and oil supply. Check oiling is required at the checking set or cleaning status is complete. Determine that necessity of checking and repair the set exists after checking the using period of the set together with the user. In this case, followings must be checked:

Phenomena	Checking Points and Cause	Replacement
Color beat	Pollution of Full-Erase Head	○
S/N, Color Faded	Pollution of Video Head	○
Horizontal, Vertical Jitte	Pollution of Video Head or Tape Transport System	○
Poor Sound, Low Sound	Pollution of Audio/Control Head	○
No tape wound or tape wound loosely, FF or REW impossible, or slow turning	Pollution of Pinch Roller or Belt Capstan Belt	○
Tape loosely wound in REV or Unloading	Deterioration of Clutch Assembly D37 Torque	○
	Pollution of Drum and Traveling Device	Fig. C-9-3

F/E Head

Video Head

A/C Head

Pinch Roller

Belt Capstan

Clutch Assembly A37

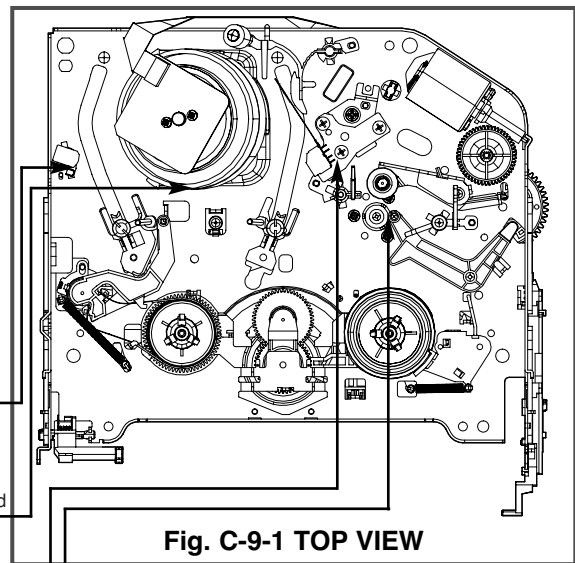

Fig. C-9-1 TOP VIEW

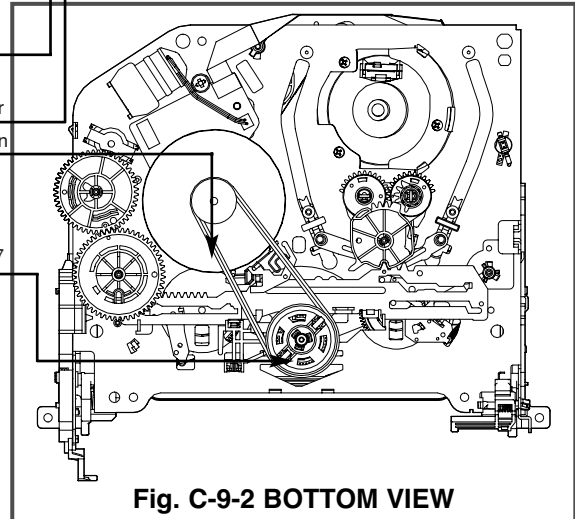

Fig. C-9-2 BOTTOM VIEW

CAUTIONS

If operation of the position with (O) mark is abnormal even after removing cause, replace it with substitute product since it shows damage or wearing.

* No. (1) ~ (12) shows sequence that the tape moves from the supply reel to the take-up reel.)

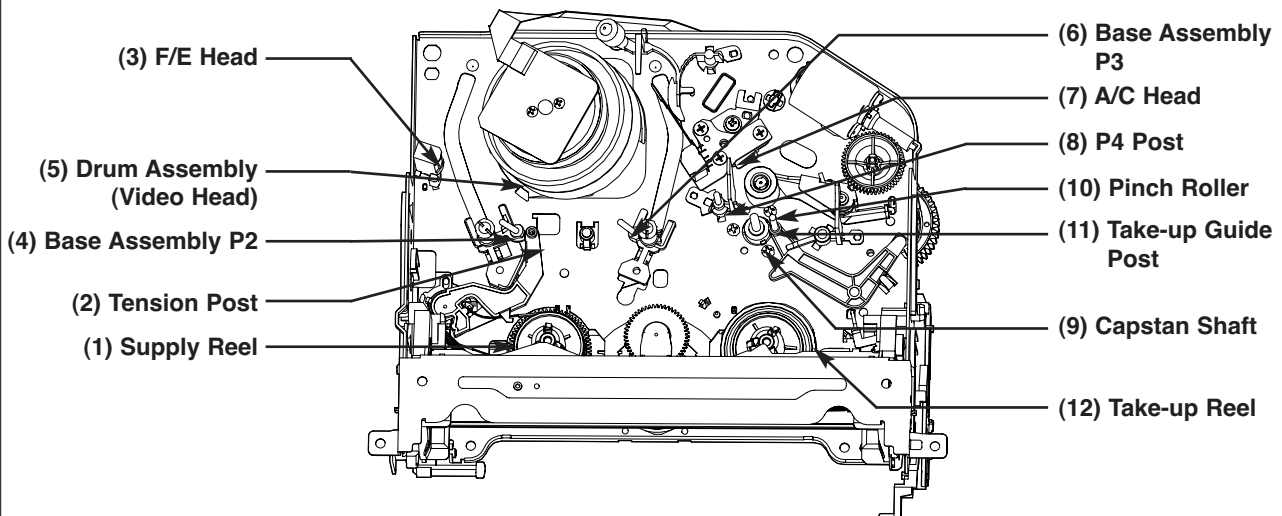

Fig. C-9-3 Tape Transport System

PROTECTION, MAINTENANCE AND CHECK OF VIDEO FUNCTION

2. Essential Check and Repair

Recording density of the video is far higher than the audio. Therefore video parts are very precise so as to allow only error of 1/1000mm or so in order to maintain compatibility with other videos.

If one of these parts is polluted or old, same phenomena will appear as they are damaged.

To maintain clear screen, regular check, replacement of old and damaged parts and oil supply, etc are essential.

3. Regular Check and Repair

Check and repair schedule is not constant since they vary depending on method that the consumer uses video and environment where the video is installed at.

However, for the video used by common household, good screen will be maintained if regular check and repair per 1,000 hour is performed. The following chart shows relationship between using time and checking time:

Table 1

Time Requiring Checking \ Average hours used per day	About 1 year	About 18 months	About 3 years
One hour	[Bar spanning all three columns]		
Two hours	[Bar spanning first two columns]		
Three hours	[Bar spanning first column]		

4. Tools for Check and Repair

- (1) Grease: Floil G-3114 (KANTO) or equivalent grease (Green)
- (2) Grease: Kanto G-754, PL-433 (Yellow)
- (3) Alcohol (Isopropyl Alcohol)
- (4) Cleaning Patch (cloth)

5. Maintenance Process

5-1) Removal of Foreign Material

- (1) Removal of foreign material from video head (Fig. C-9-4)
Firstly try to use a cleaning tape.

Use a cleaning patch if foreign materials are not removed with the cleaning tape due to severe dirty of the head. Soak the cleaning patch in alcohol and put it to the head tip. Smoothly turn the drum (turning cylinder) to the right or left (In this case, the cleaning patch must not be moved vertically).

After completely drying the head, test the traveling status of the tape.

If alcohol (Isopropyl Alcohol) remains at the video head, the tape may be damaged when this solution touches with the head surface.

Never use a cloth bar (commercial sale)

- (2) Wipe the tape transport system and the drive system with the cleaning patch soaked in alcohol (Isopropyl Alcohol) when removing foreign materials from them.
 - 1) The part touched with the traveling tape is called as tape transport system. The drive system consists of parts to travel the tape.
 - 2) Care must be exercised so that unreasonable force to change the pattern will be applied to the tape transport system during removal of foreign materials.

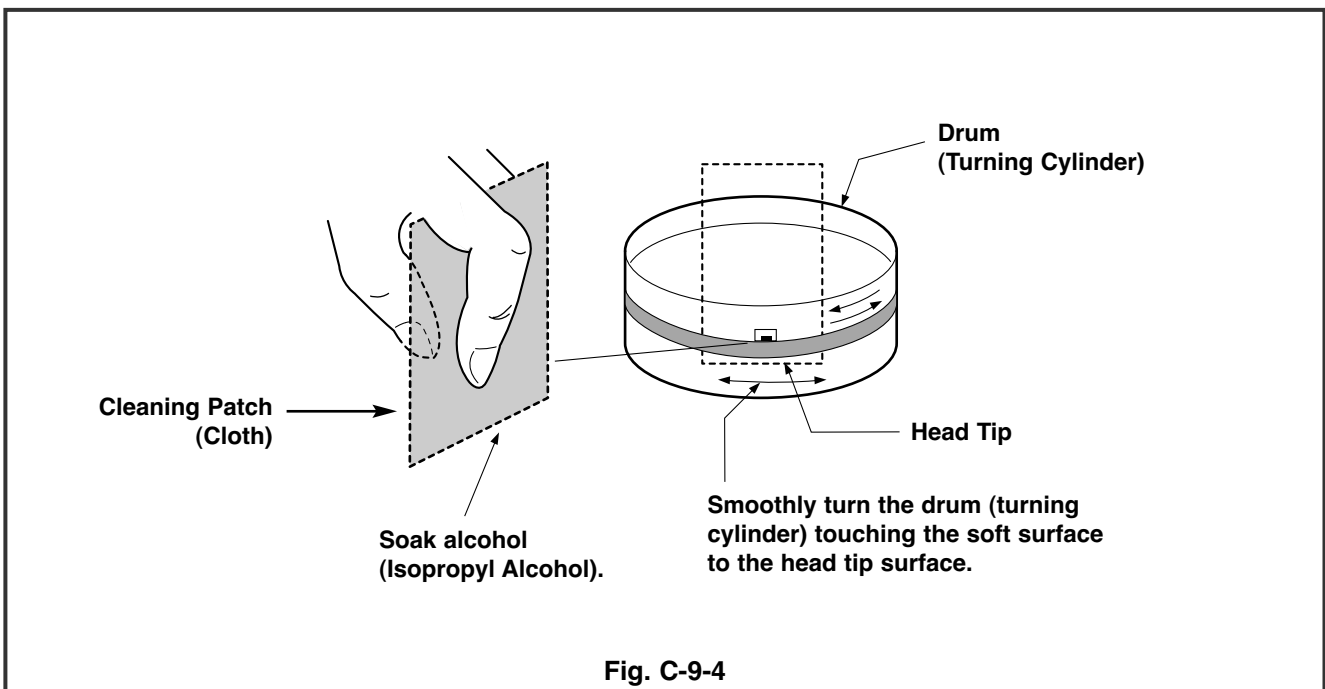

Fig. C-9-4

PROTECTION, MAINTENANCE AND CHECK OF VIDEO FUNCTION

5-2) Grease Applications

(1) Grease Application Method

Apply grease by using a cloth swab or brush. Care must be exercised so that excess quantity should not be used. If the excessive quantity is applied, wipe it with the gauze soaked in alcohol (Isopropyl Alcohol).

NOTE: POSITION OF GREASE APPLICATION

- | | |
|--|----------------------------------|
| (1) Inner Side Surface and Top Surface of Loading Path | (4) Gear Wheel Shaft |
| (2) Stable Adhesion Part of Base P2, P3 | (5) Reel S. T. Shaft |
| (3) Arm Pinch Shaft | (1) (2) (3) (4): KG-684G (Green) |
| | (5): PL-433 (Yellow) |

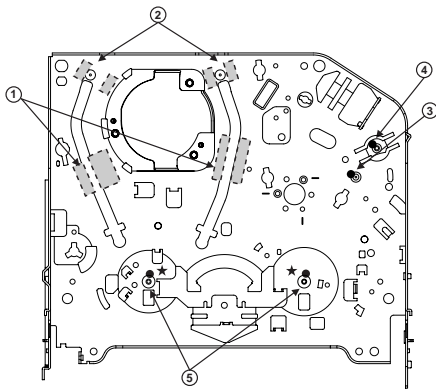

Chassis (TOP)

Gear Part

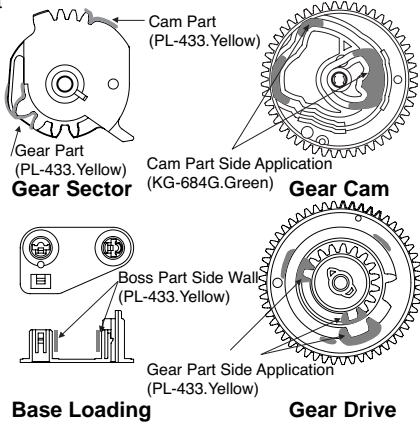

(2) Regular Grease Application

Apply grease to the designated application position every 500 hour.

- | | |
|--|--|
| (1) Inner Side Surface and Top Surface of Loading Path | (6) Guide Part on the Plate Slider Side Wall (Left) |
| (2) Stable Adhesion Part of Base P2, P3 Coil | (7) Guide Part on the Plate Slider Side Wall (Right) |
| (3) Gear Cam Shaft | (1) (2) (3) (4) (5) (6) (7): KG-684G (Green) |
| (4) Gear Drive Shaft | |
| (5) Clutch Shaft Groove | |

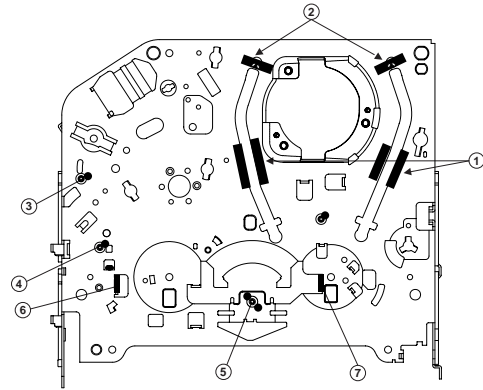

Chassis (Bottom)

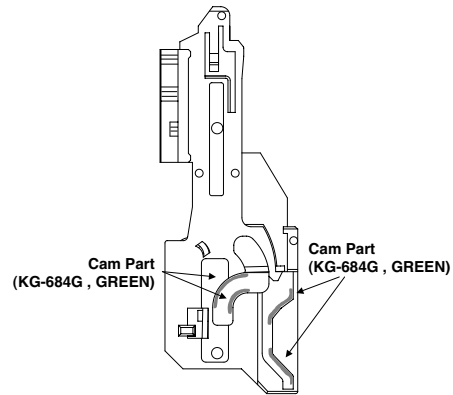

Gear Rack F/L

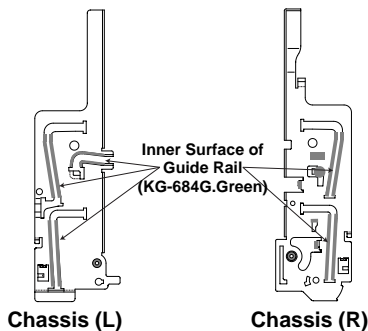

Chassis (L)

Chassis (R)

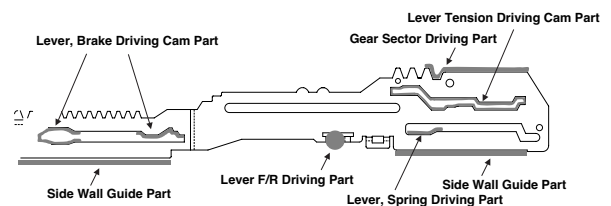
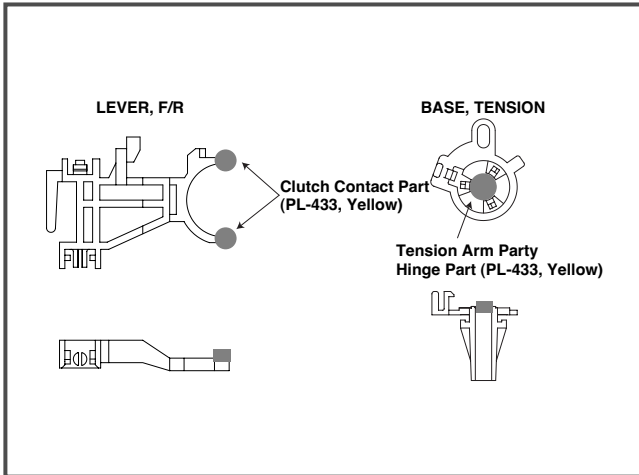

Plate Slider

PROTECTION, MAINTENANCE AND CHECK OF VIDEO FUNCTION

Lever, F/R, Base, Tension



GEAR AY, P2 & P3

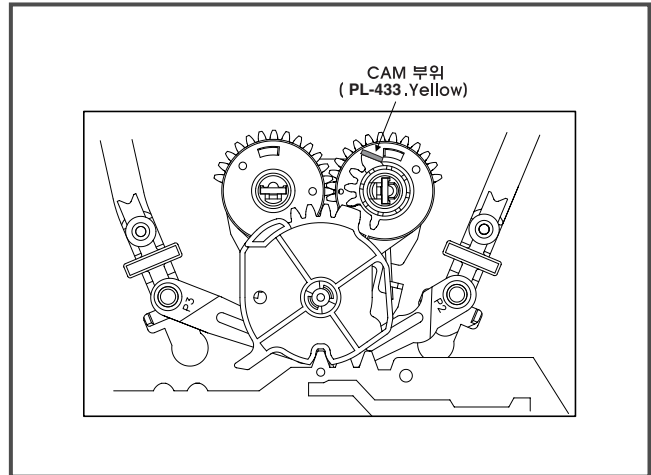

MECHANISM TROUBLESHOOTING GUIDE

1. Deck Mechanism

A.

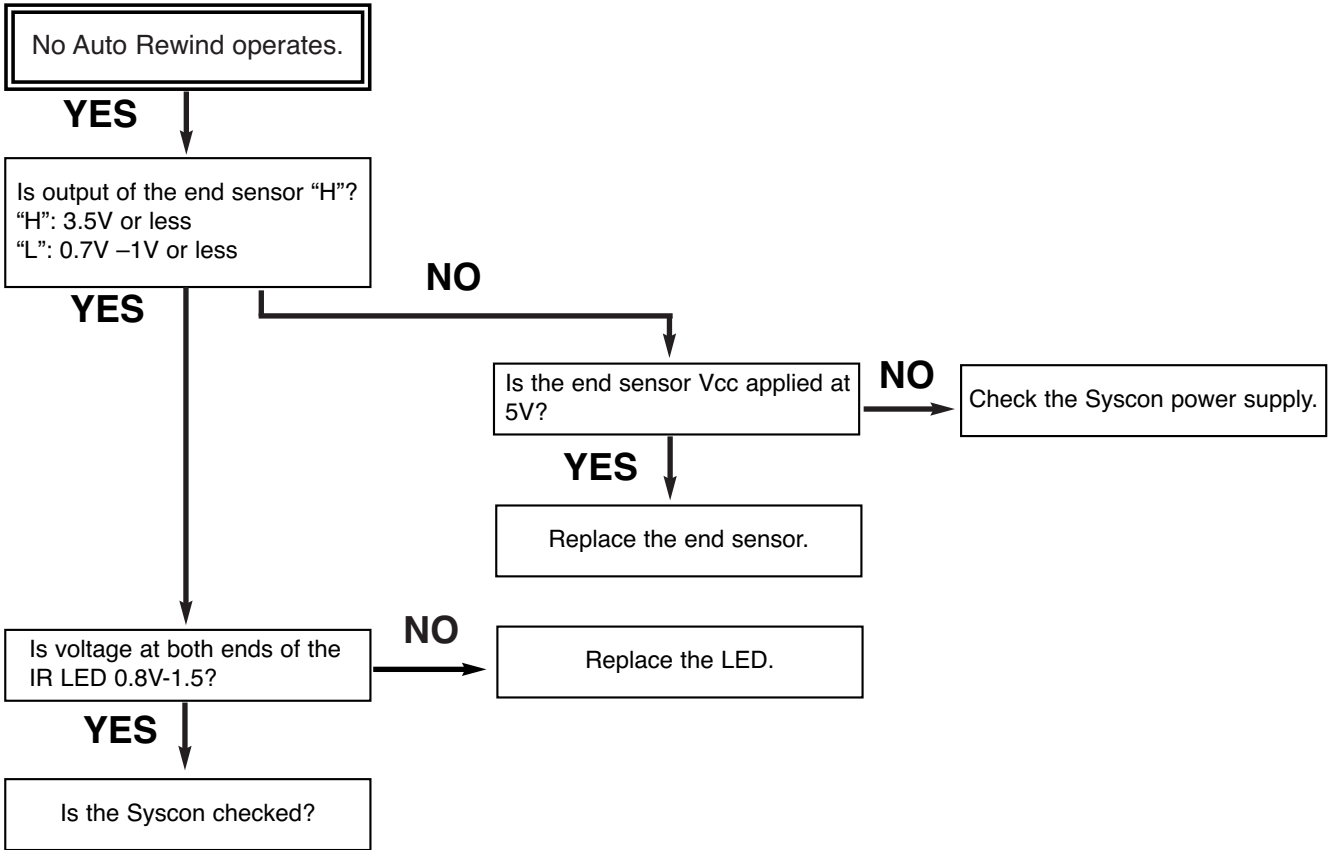

B.

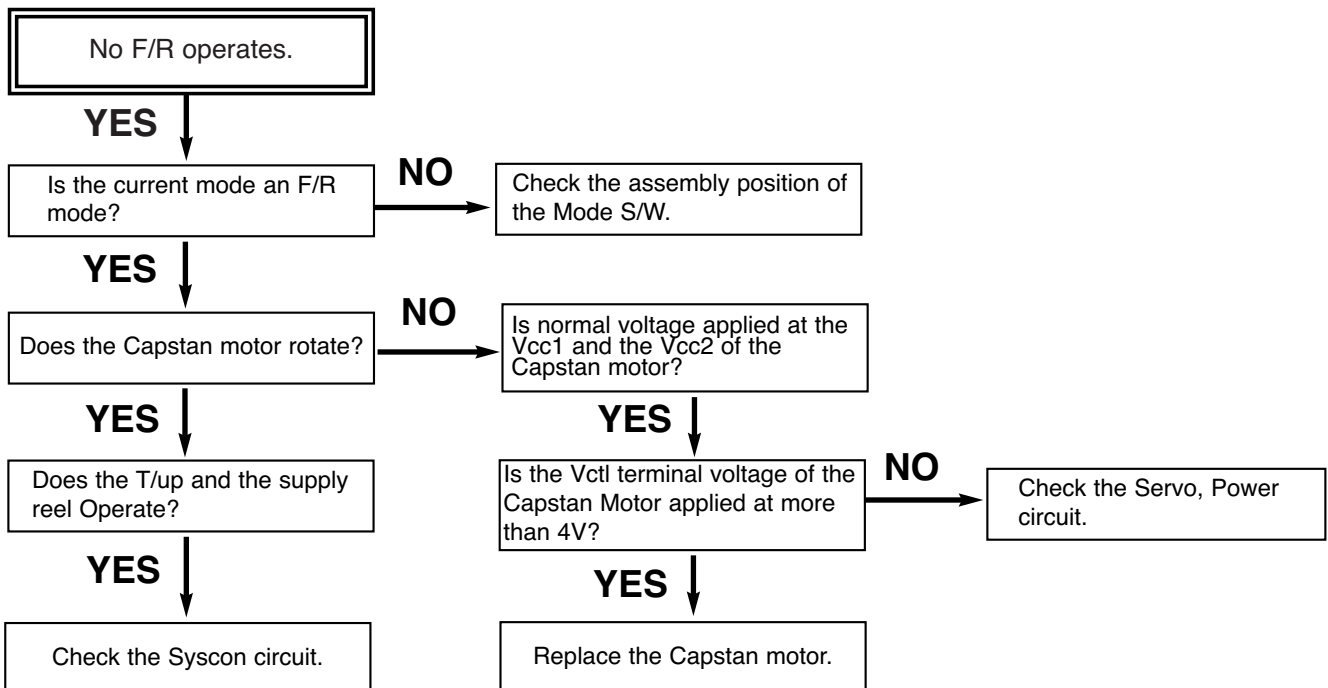

MECHANISM TROUBLESHOOTING GUIDE

C.

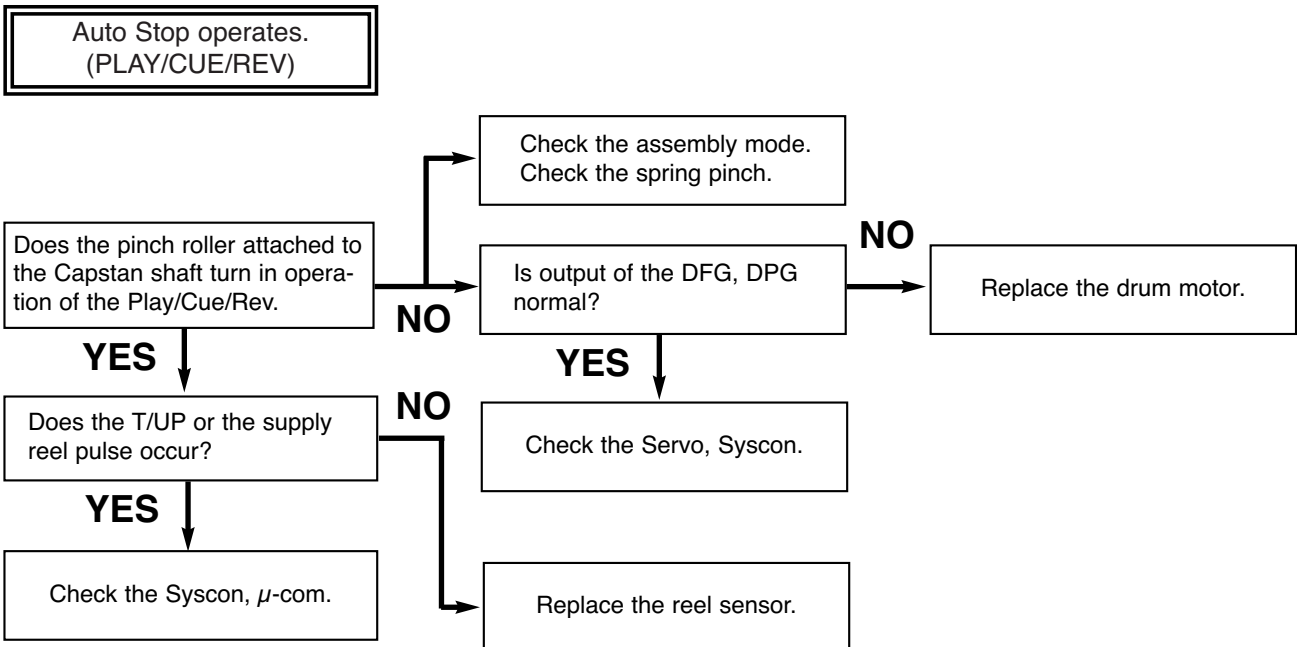

D.

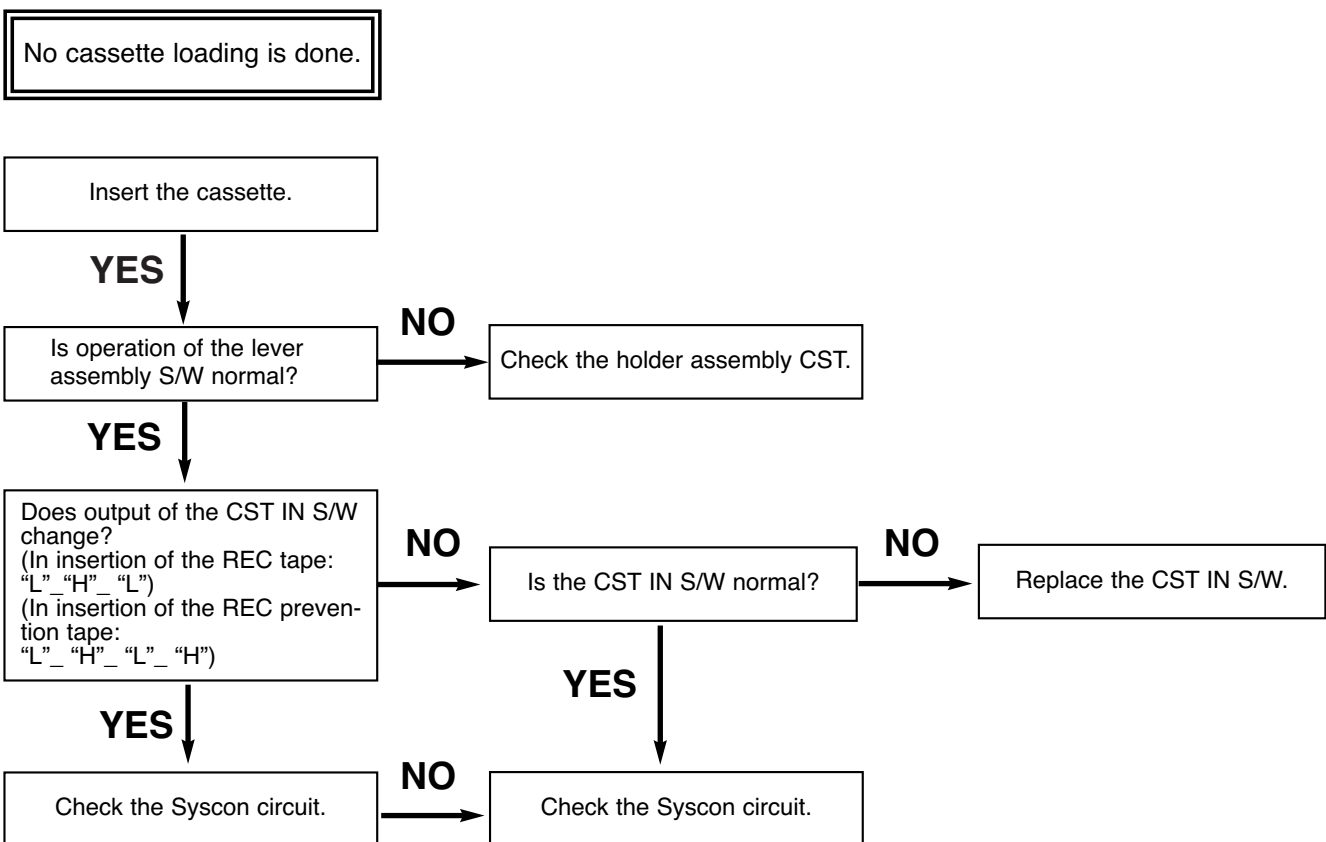

MECHANISM TROUBLESHOOTING GUIDE

E.

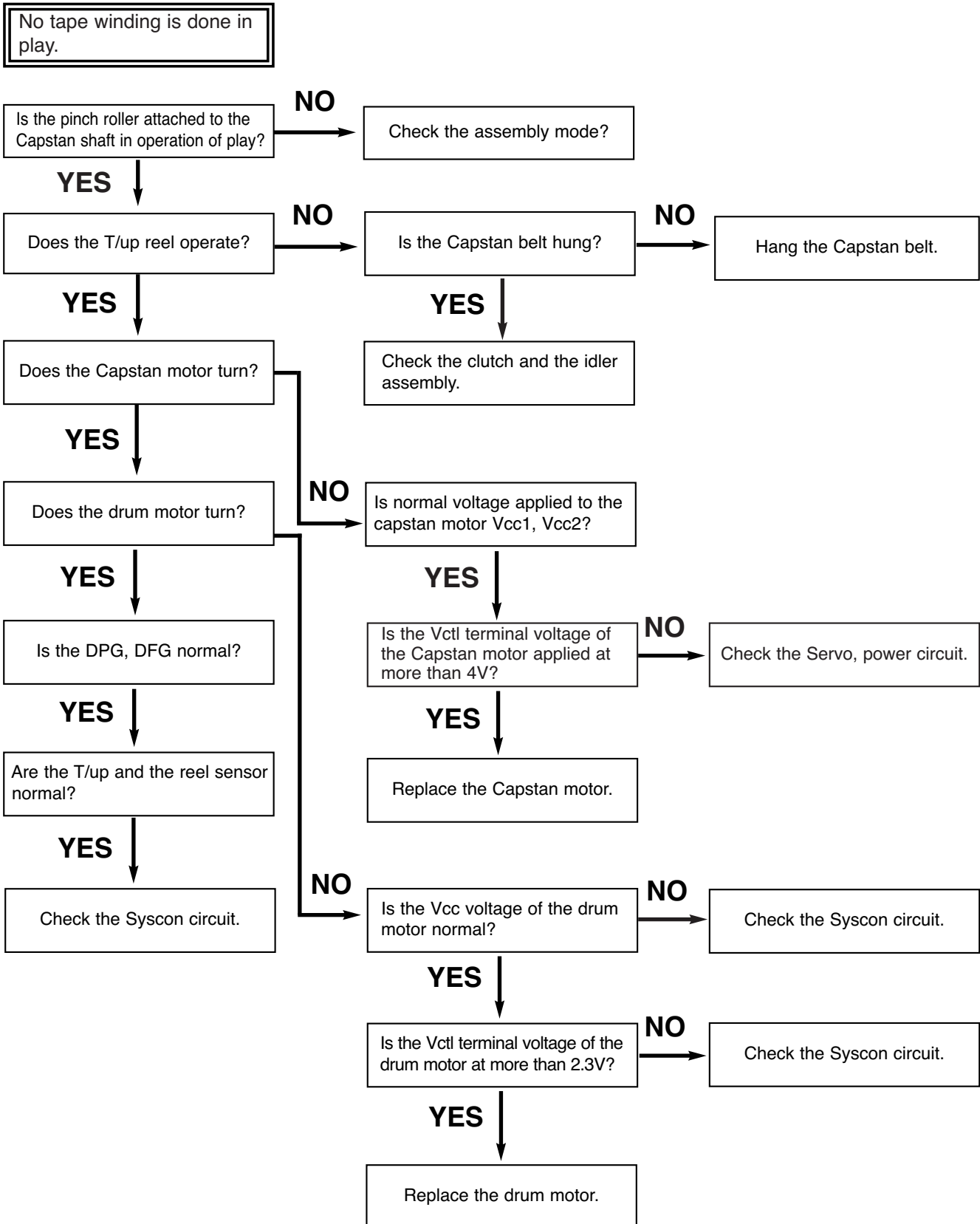

MECHANISM TROUBLESHOOTING GUIDE

2. Front Loading Mechanism

A.

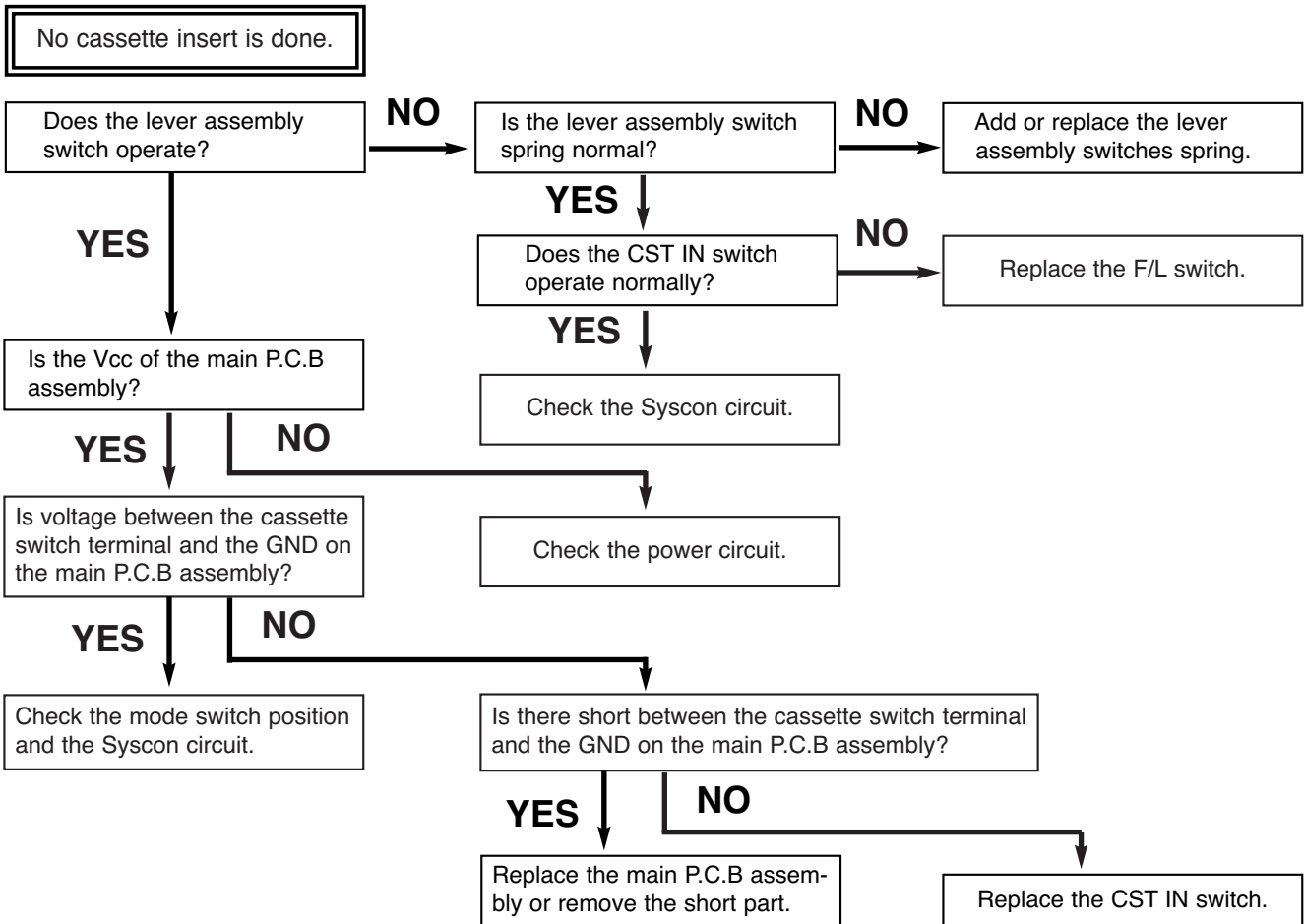

B.

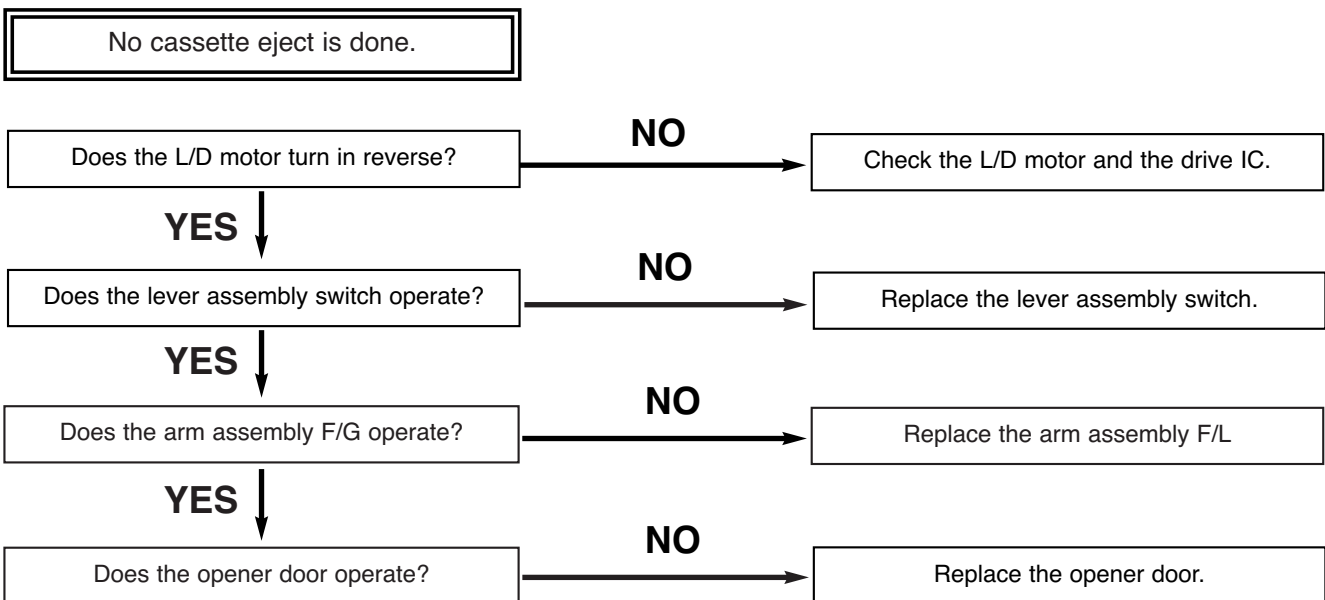

MECHANISM TROUBLESHOOTING GUIDE

C.

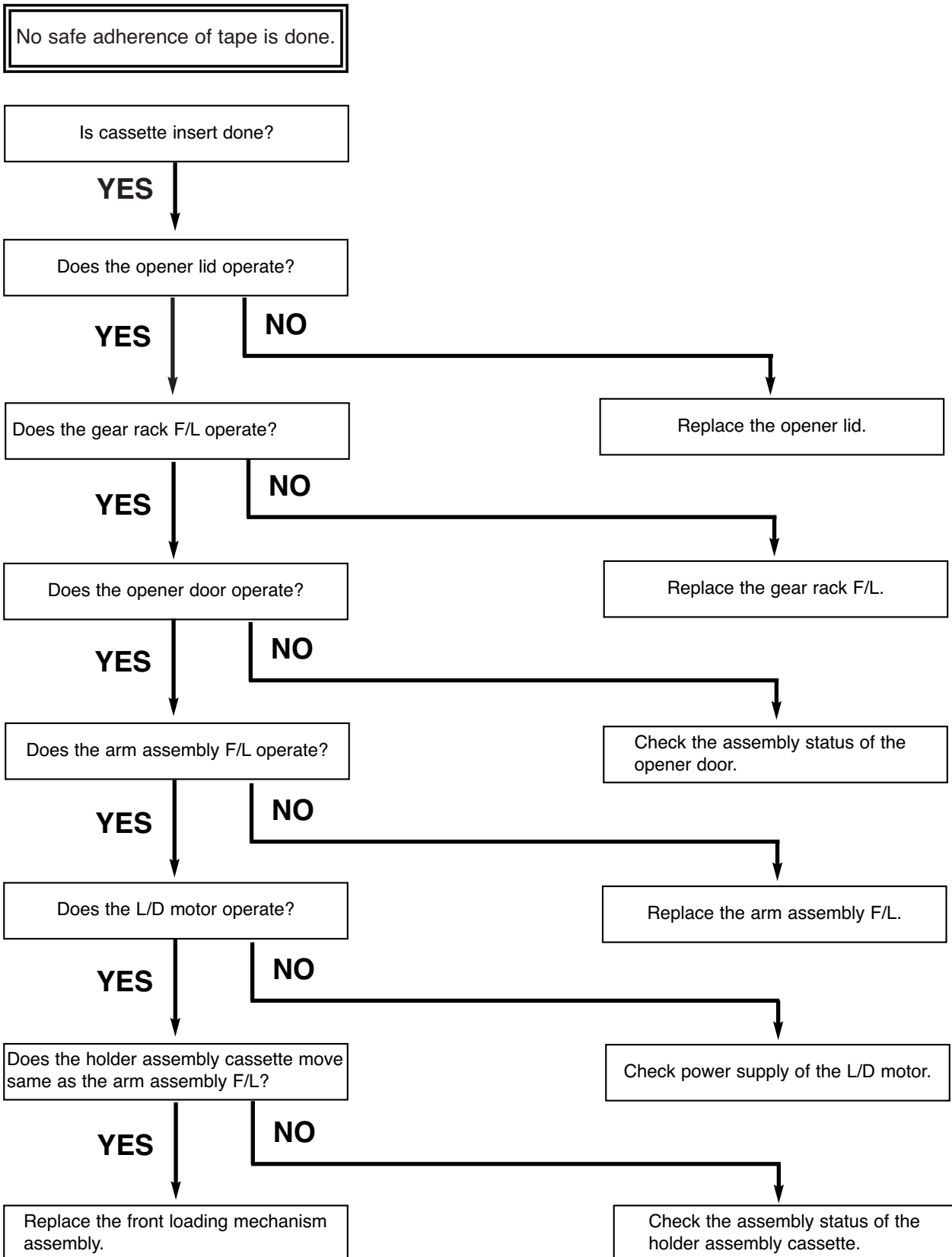

EXPLODED VIEWS

1. Front Loading Mechanism Section

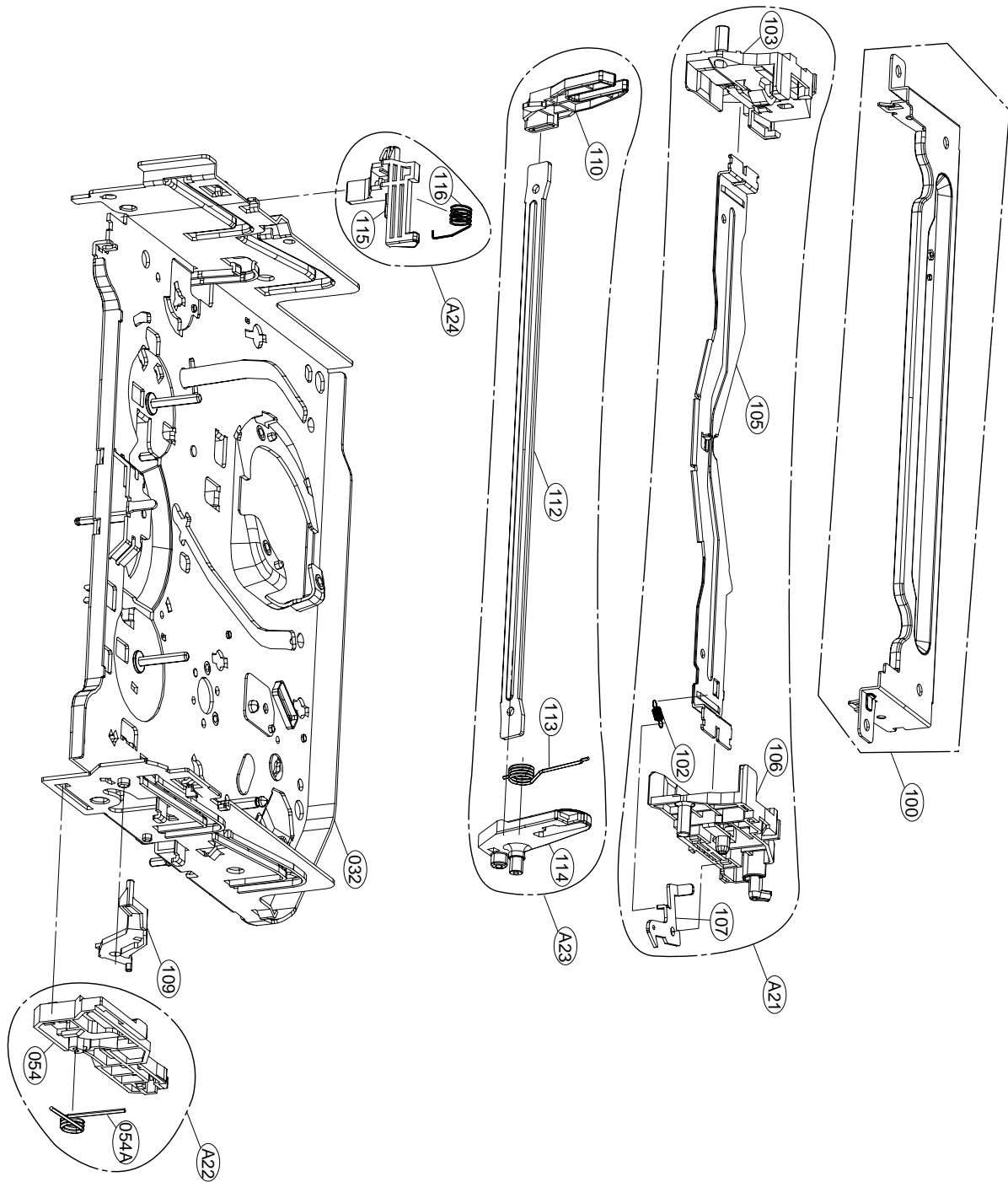

EXPLODED VIEWS

2. Moving Mechanism Section (1)

★ OPTIONAL PART

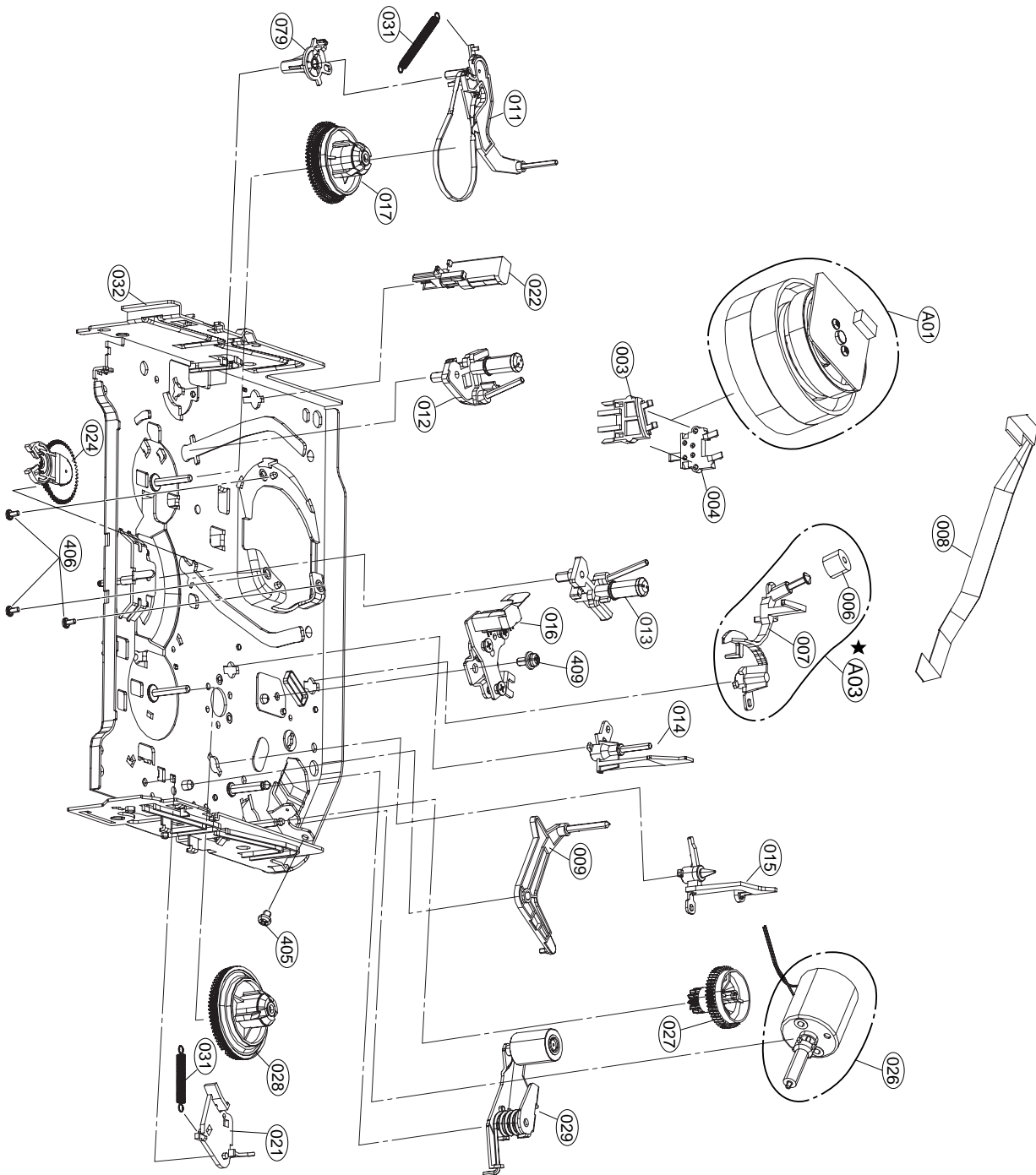

EXPLODED VIEWS

3. Moving Mechanism Section (2)

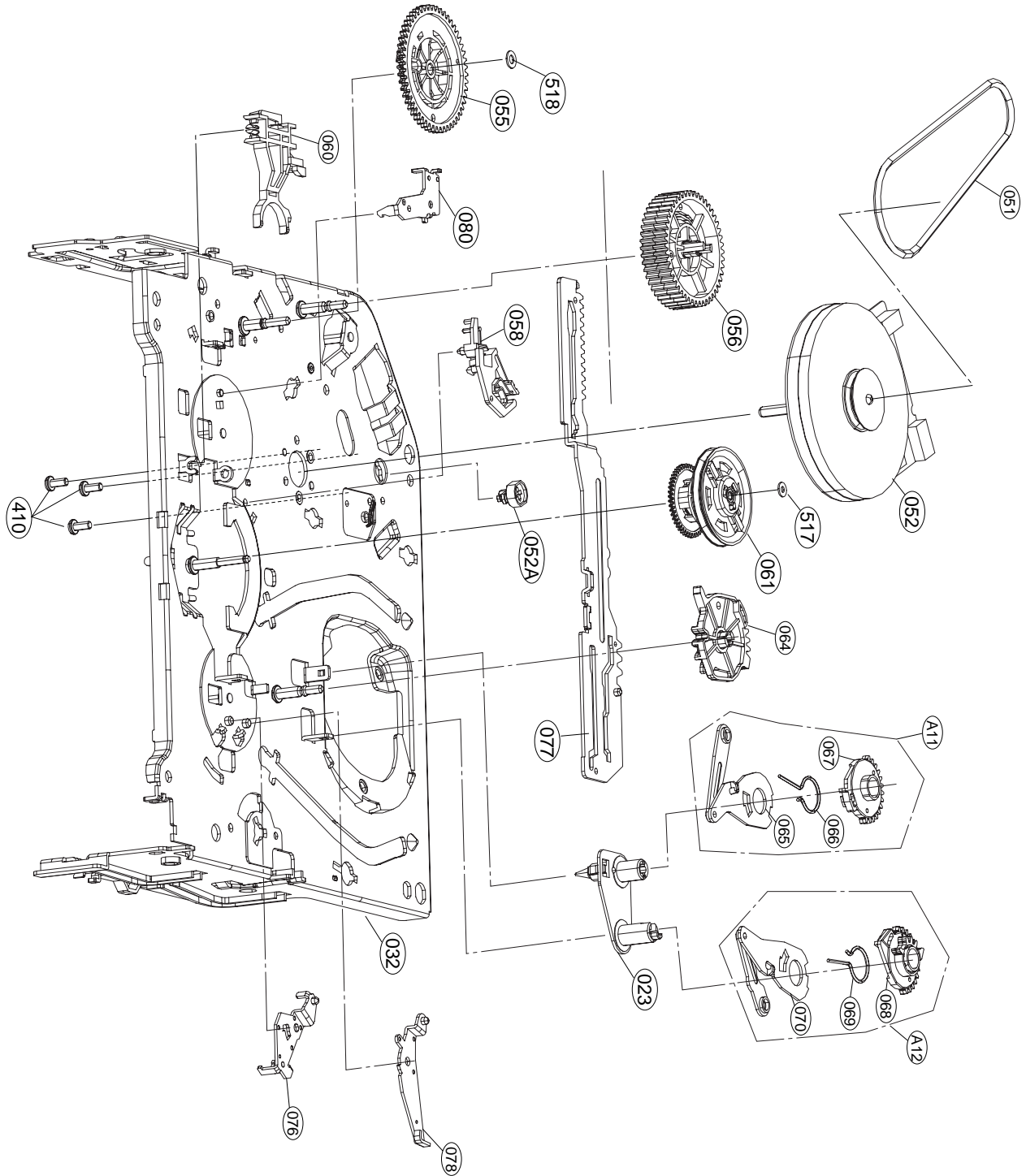

SECTION 5 MECHANISM OF DVD PART

CONTENTS

DECK MECHANISM PARTS LOCATIONS

- Top View.....5-1
- Top View(without Tray Disc)5-1
- Bottom View5-1

DECK MECHANISM DISASSEMBLY

- 1. Holder Clamp.....5-2
 - 1-1. Clamp Assembly Disc.....5-2
 - 1-1-1. Plate Clamp5-2
 - 1-1-2. Magnet Clamp5-2
 - 1-1-3. Clamp Upper.....5-2
- 2. Tray Disc5-2
- 3. Base Assembly Sled5-3
 - 3-1. Gear Assembly Feed5-3
 - 3-2. Gear Assembly Middle.....5-3
 - 3-3. Gear Assembly Rack5-3
- 4. Rubber Rear.....5-3

- 5. Frame Assembly Up/Down.....5-4
- 6. Belt Loading.....5-4
- 7. Gear Pulley5-4
- 8. Gear Loading5-4
- 9. Guide Up/Down.....5-4
- 10. PWB Assembly Loading.....5-4
- 11. Base Main.....5-4

EXPLODED VIEW

- 1. Deck Mechanism Exploded View....5-5
-

DECK MECHANISM PARTS LOCATION

• Top View (With Tray)

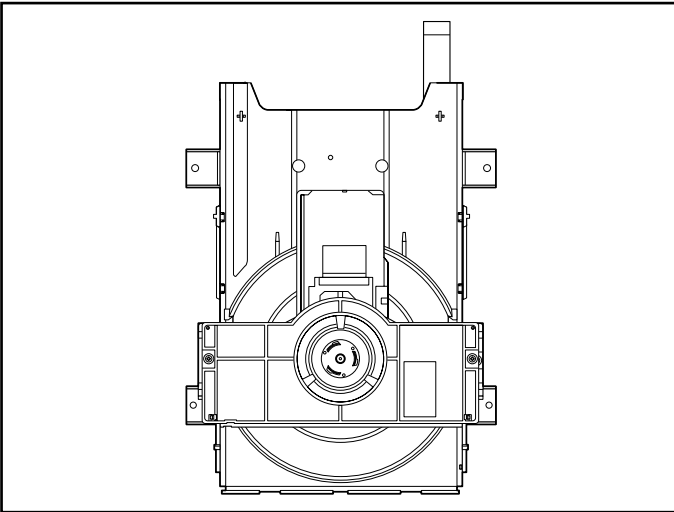

• Top View (Without Tray)

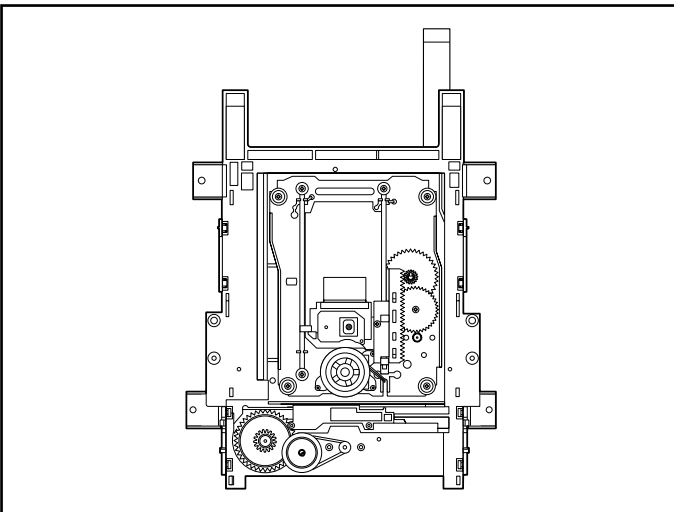

• Bottom View

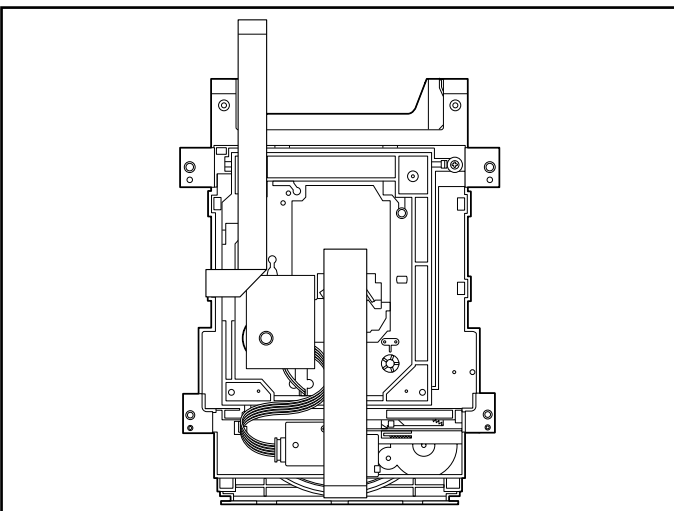

Procedure		Parts	Fixing Type	Disassembly	Figure
Starting No.					
	1	Holder Clamp	2 Screws, 2 Locking Tabs		5-1
1	2	Clamp Assembly Disc			5-1
1, 2	3	Plate Clamp			5-1
1, 2, 3	4	Magnet Clamp			5-1
1, 2, 3, 4	5	Clamp Upper			5-1
1	6	Tray Disc			5-2
1, 6	7	Base Assembly Sled	4 Screws,		5-3
1, 2, 6	8	Gear Assembly Feed			5-3
1, 2, 6, 8	9	Gear Middle			5-3
1, 2, 6, 8, 9	10	Gear Assembly Rack	1 Screw		5-3
1, 2, 7	11	Rubber Rear			5-3
1, 2, 7	12	Frame Assembly Up/Down	1 Screw	Bottom	5-4
1, 2	13	Belt Loading	1 Locking Tab		5-4
1, 2, 13	14	Gear Pulley			5-4
1, 2, 13, 14	15	Gear Loading	1 Locking Tab		5-4
1, 2, 7, 12, 13, 14	16	Guide Up/Down			5-4
1, 2, 13	17	PWB Assembly Loading	1 Locking Tab 1 Hook 2Screw	Bottom	5-4
1, 2, 7, 12, 13, 14, 15, 16, 17	18	Base Main			5-4

Note

When reassembling, perform the procedure in reverse order.

The "Bottom" on Disassembly column of above Table indicates the part should be disassembled at the Bottom side.

DECK MECHANISM DISASSEMBLY

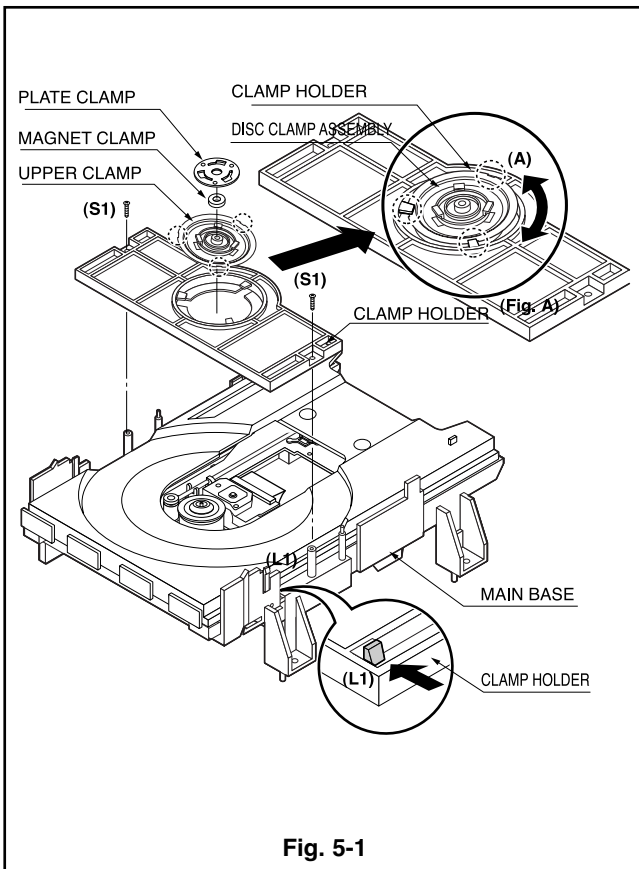

Fig. 5-1

1. Holder Clamp (Fig. 5-1)

- 1) Release 2 Screws(S1).
- 2) Unhook 2 Locking Tabs(L1).
- 3) Lift up the Holder Clamp and then separate it from the Base Main.

1-1. Clamp Assembly Disc

- 1) Place the Clamp Assembly Disc as Fig. (A)
- 2) Lift up the Clamp Assembly Disc in direction of arrow(A).
- 3) Separate the Clamp Assembly Disc from the Holder Clamp.

1-1-1. Plate Clamp

- 1) Turn the Plate Clamp to counterclockwise direction and then lift up the Plate Clamp.

1-1-2. Magnet Clamp

1-1-3. Clamp Upper

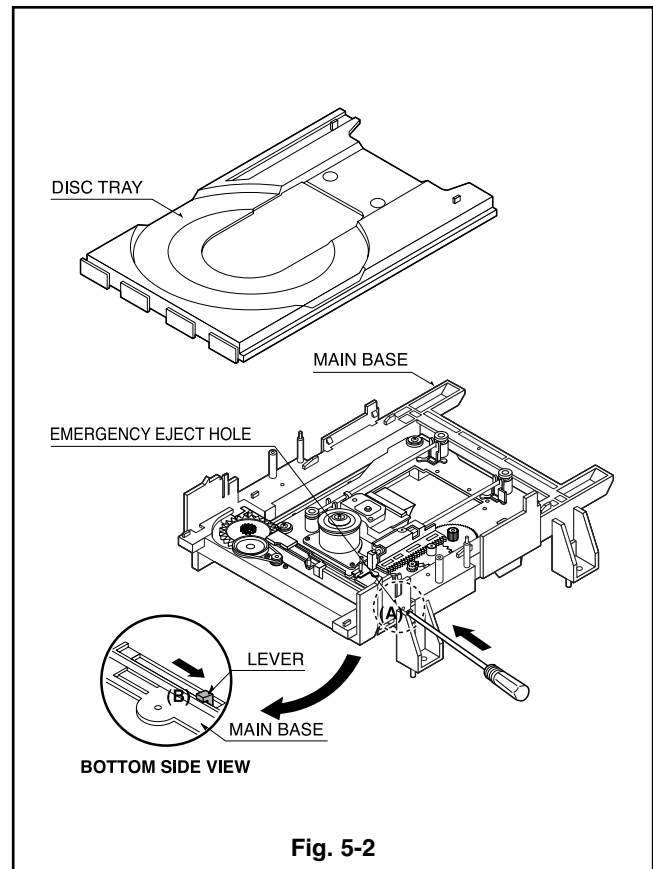

Fig. 5-2

2. Tray Disc (Fig. 5-2)

- 1) Insert and push a Driver in the emergency eject hole(A) at the right side, or put the Driver on the Lever(B) of the Gear Emergency and pull the Lever(B) in direction of arrow so that the Tray Disc is ejected about 15~20mm.
- 2) Pull the Tray Disc until it is separated from the Base Main completely.

DECK MECHANISM DISASSEMBLY

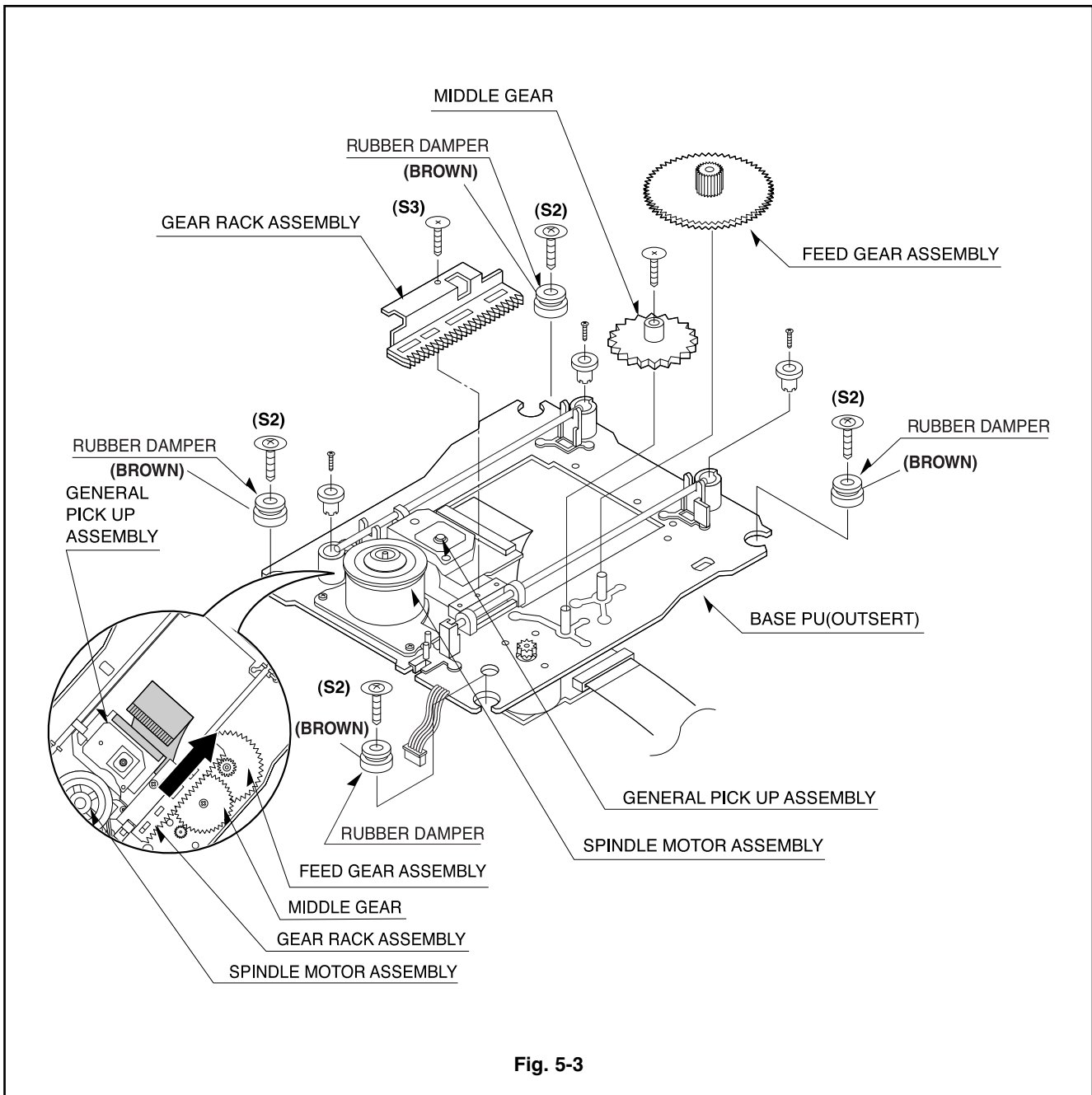

Fig. 5-3

3. Base Assembly Sled (Fig. 5-3)

- 1) Release 4 Screw(S2).
- 2) Disconnect the FFC Connector(C1)

3-1. Gear Assembly Feed

3-2. Gear Middle

3-3. Gear Assembly Rack

- 1) Release the Scerw(S3)

4. Rubber Rear (Fig. 5-3)

DECK MECHANISM DISASSEMBLY

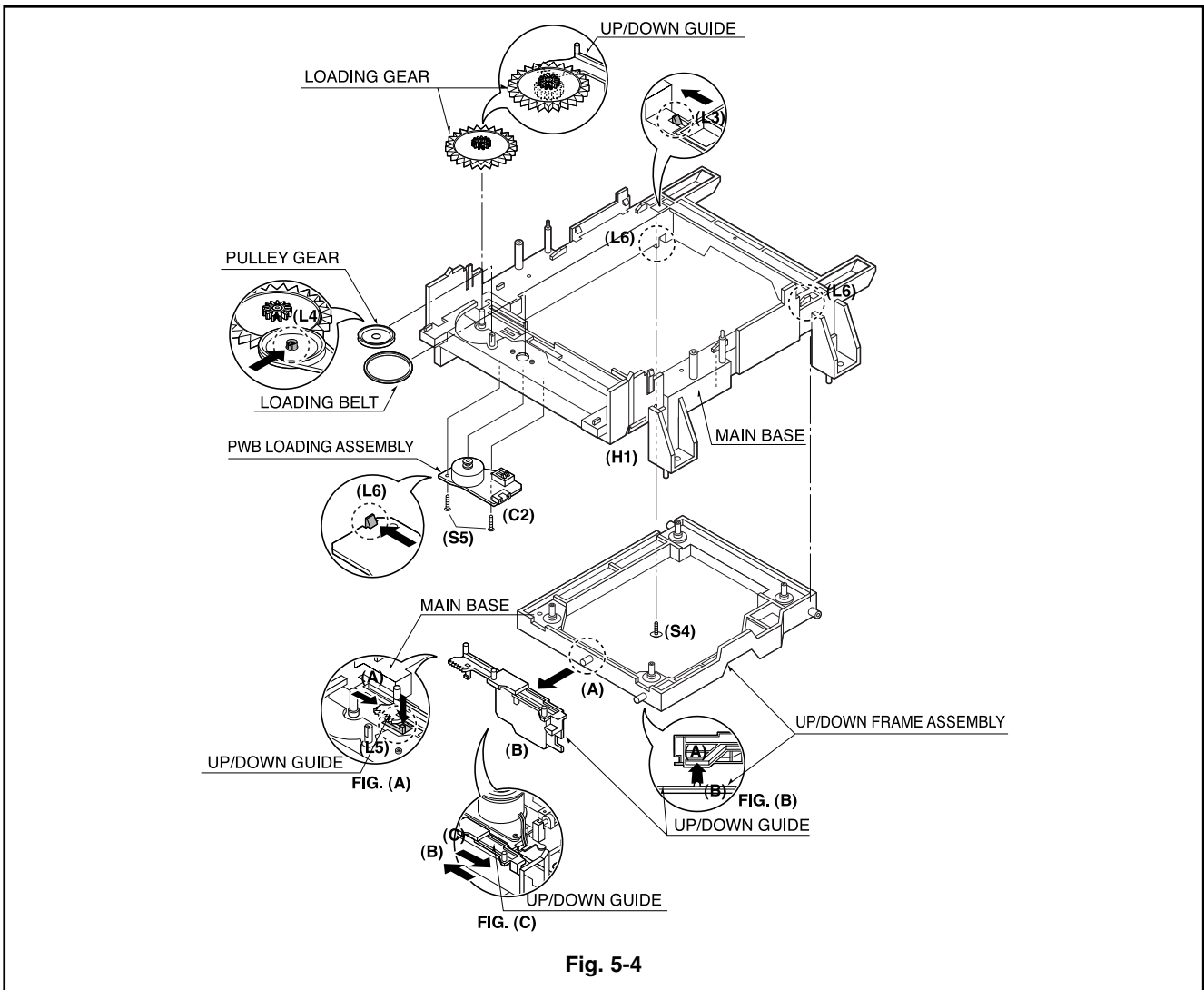

Fig. 5-4

5. Frame Assembly Up/Down (Fig. 5-4)

Note

Put the Base Main face down(Bottom Side)

- 1) Release the Screw(S4)
- 2) Unlock the Locking Tab(L3) in direction of arrow and then lift up the Frame Assembly Up/Down to separate it from the Base Main.

Note

- When reassembling move the Guide Up/Down in direction of arrow(C) until it is positioned as Fig.(C).
- When reassembling insert (A) portion of the Frame Assembly Up/Down in the (B) portion of the Guide Up/Down as Fig.(B)

6. Belt Loading(Fig. 5-4)

Note

Put the Base Main on original position(Top Side)

7. Gear pulley (Fig. 5-4)

- 1) Unlock the Locking Tab(L4) in direction of arrow(B) and then separate the Gear Pulley from the Base Main.

8. Gear Loading (Fig. 5-4)

9. Guide Up/Down (Fig. 5-4)

- 1) Move the Guide Up/Down in direction of arrow(A) as Fig.(A)
- 2) Push the Locking Tab(L5) down and then lift up the Guide Up/Down to separate it from the Base Main.

Note

When reassembling place the Guide Up/Down as Fig.(C) and move it in direction arrow(B) until it is locked by the Locking Tab(L5). And confirm the Guide Up/Down as Fig.(A)

10. PWB Assembly Loading (Fig. 5-4)

Note

Put the Base Main face down(Bottom Side)

- 1) Release 2 Screws(S5)
- 2) Unlock the Loading Motor (C2) from the Hook (H1) on the Base Main.
- 3) Unlock 2 Locking Tabs(L6) and separate the PWB Assembly Loading from the Base Main.

11. Base Main(Fig. 5-4)

MEMO

A series of horizontal dotted lines for writing.

EXPLODED VIEWS

1. Deck Mechanism Exploded View

