

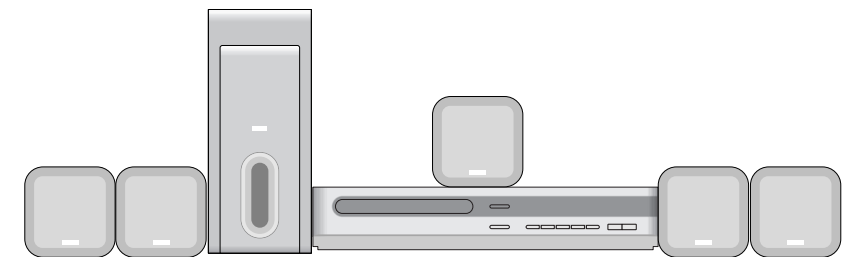

SERVICE MANUAL MODEL: LH-T6240 LHS-T6240T, LHS-T6240W



DVD/CD RECEIVER SERVICE MANUAL



MODEL: LH-T6240 LHS-T6240T, LHS-T6240W

LG Electronics Inc.

[CONTENTS]

○ SECTION 1. GENERAL

- SERVICING PRECAUTIONS 1-2
- ESD PRECAUTIONS 1-4
- SPECIFICATIONS 1-5

○ SECTION 2. AUDIO PART

- AUDIO TROUBLESHOOTING GUIDE 2-1
- BLOCK DIAGRAM 2-5
- SCHEMATIC DIAGRAMS 2-7
- WIRING DIAGRAM 2-17
- PRINTED CIRCUIT DIAGRAMS 2-19

○ SECTION 3. DVD PART TROUBLESHOOTING GUIDE

- ELECTRICAL TROUBLESHOOTING GUIDE 3-1
- DVD PART SCHEMATIC DIAGRAMS 3-7

○ SECTION 4. EXPLODED VIEWS 4-1

○ SECTION 5. SPEAKER PART 5-1

○ SECTION 6. REPLACEMENT PARTS LIST 6-1

3. FRONT CIRCUIT (2/2)

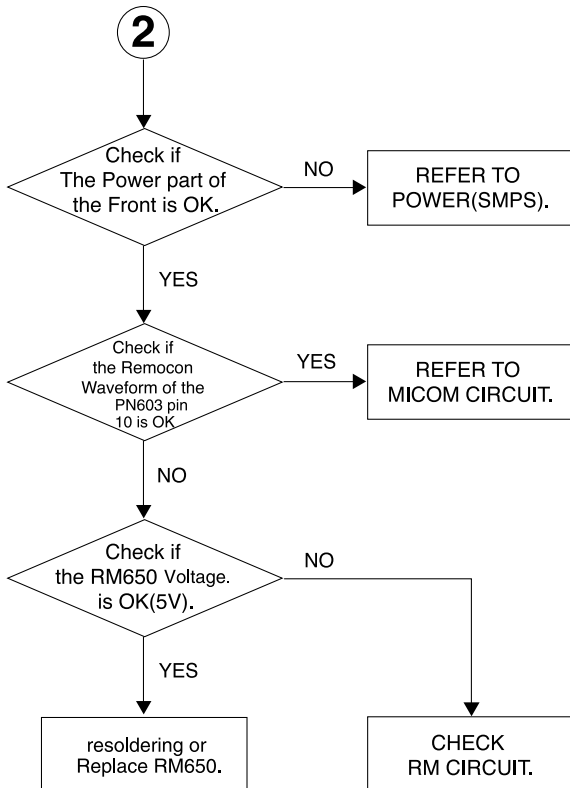
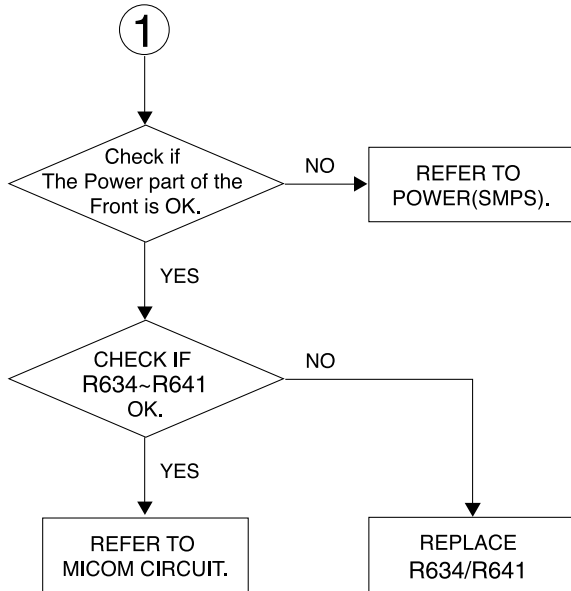

SECTION 1. GENERAL

□ SERVICING PRECAUTIONS

NOTES REGARDING HANDLING OF THE PICK-UP

1. Notes for transport and storage

- 1) The pick-up should always be left in its conductive bag until immediately prior to use.
- 2) The pick-up should never be subjected to external pressure or impact.

Storage in conductive bag

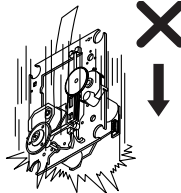
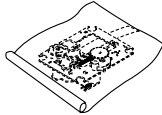

Drop impact

2. Repair notes

- 1) The pick-up incorporates a strong magnet, and so should never be brought close to magnetic materials.
- 2) The pick-up should always be handled correctly and carefully, taking care to avoid external pressure and impact. If it is subjected to strong pressure or impact, the result may be an operational malfunction and/or damage to the printed-circuit board.
- 3) Each and every pick-up is already individually adjusted to a high degree of precision, and for that reason the adjustment point and installation screws should absolutely never be touched.
- 4) Laser beams may damage the eyes!
Absolutely never permit laser beams to enter the eyes!
Also NEVER switch ON the power to the laser output part (lens, etc.) of the pick-up if it is damaged.

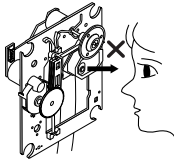

NEVER look directly at the laser beam, and don't let contact fingers or other exposed skin.

5) Cleaning the lens surface

If there is dust on the lens surface, the dust should be cleaned away by using an air bush (such as used for camera lens). The lens is held by a delicate spring. When cleaning the lens surface, therefore, a cotton swab should be used, taking care not to distort this.

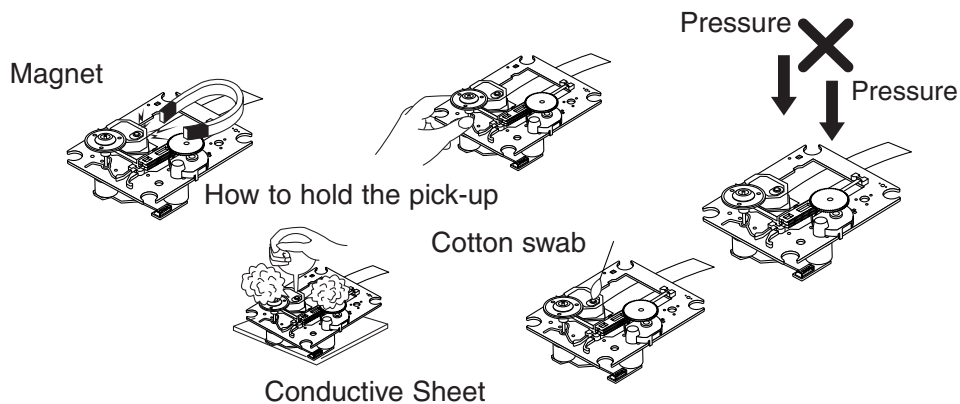

6) Never attempt to disassemble the pick-up.

Spring by excess pressure. If the lens is extremely dirty, apply isopropyl alcohol to the cotton swab. (Do not use any other liquid cleaners, because they will damage the lens.) Take care not to use too much of this alcohol on the swab, and do not allow the alcohol to get inside the pick-up.

NOTES REGARDING COMPACT DISC PLAYER REPAIRS

1. Preparations

- 1) Compact disc players incorporate a great many ICs as well as the pick-up (laser diode). These components are sensitive to, and easily affected by, static electricity. If such static electricity is high voltage, components can be damaged, and for that reason components should be handled with care.
- 2) The pick-up is composed of many optical components and other high-precision components. Care must be taken, therefore, to avoid repair or storage where the temperature or humidity is high, where strong magnetism is present, or where there is excessive dust.

2. Notes for repair

- 1) Before replacing a component part, first disconnect the power supply lead wire from the unit
- 2) All equipment, measuring instruments and tools must be grounded.
- 3) The workbench should be covered with a conductive sheet and grounded.
When removing the laser pick-up from its conductive bag, do not place the pick-up on the bag. (This is because there is the possibility of damage by static electricity.)
- 4) To prevent AC leakage, the metal part of the soldering iron should be grounded.
- 5) Workers should be grounded by an armband (1M Ω)
- 6) Care should be taken not to permit the laser pick-up to come in contact with clothing, in order to prevent static electricity changes in the clothing to escape from the armband.
- 7) The laser beam from the pick-up should NEVER be directly facing the eyes or bare skin.

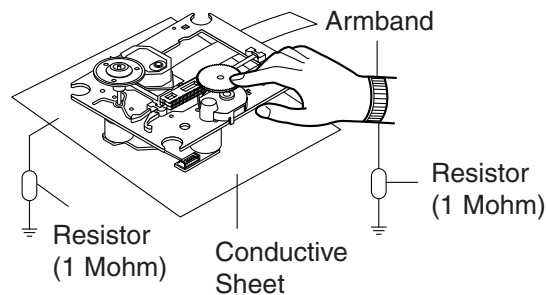

□ ESD PRECAUTIONS

Electrostatically Sensitive Devices (ESD)

Some semiconductor (solid state) devices can be damaged easily by static electricity. Such components commonly are called Electrostatically Sensitive Devices (ESD). Examples of typical ESD devices are integrated circuits and some field-effect transistors and semiconductor chip components. The following techniques should be used to help reduce the incidence of component damage caused by static electricity.

1. Immediately before handling any semiconductor component or semiconductor-equipped assembly, drain off any electrostatic charge on your body by touching a known earth ground. Alternatively, obtain and wear a commercially available discharging wrist strap device, which should be removed for potential shock reasons prior to applying power to the unit under test.
2. After removing an electrical assembly equipped with ESD devices, place the assembly on a conductive surface such as aluminum foil, to prevent electrostatic charge buildup or exposure of the assembly.
3. Use only a grounded-tip soldering iron to solder or unsolder ESD devices.
4. Use only an anti-static solder removal device. Some solder removal devices not classified as "anti-static" can generate electrical charges sufficient to damage ESD devices.
5. Do not use freon-propelled chemicals. These can generate electrical charges sufficient to damage ESD devices.
6. Do not remove a replacement ESD device from its protective package until immediately before you are ready to install it. (Most replacement ESD devices are packaged with leads electrically shorted together by conductive foam, aluminum foil or comparable conductive materials).
7. Immediately before removing the protective material from the leads of a replacement ESD device, touch the protective material to the chassis or circuit assembly into which the device will be installed.

CAUTION : BE SURE NO POWER IS APPLIED TO THE CHASSIS OR CIRCUIT, AND OBSERVE ALL OTHER SAFETY PRECAUTIONS.

8. Minimize bodily motions when handling unpackaged replacement ESD devices. (Otherwise harmless motion such as the brushing together of your clothes fabric or the lifting of your foot from a carpeted floor can generate static electricity sufficient to damage an ESD device).

CAUTION. GRAPHIC SYMBOLS



THE LIGHTNING FLASH WITH APROWHEAD SYMBOL. WITHIN AN EQUILATERAL TRIANGLE, IS INTENDED TO ALERT THE SERVICE PERSONNEL TO THE PRESENCE OF UNINSULATED "DANGEROUS VOLTAGE" THAT MAY BE OF SUFFICIENT MAGNITUDE TO CONSTITUTE A RISK OF ELECTRIC SHOCK.



THE EXCLAMATION POINT WITHIN AN EQUILATERAL TRIANGLE IS INTENDED TO ALERT THE SERVICE PERSONNEL TO THE PRESENCE OF IMPORTANT SAFETY INFORMATION IN SERVICE LITERATURE.

□ SPECIFICATIONS

[General]	Power supply	Refer to main label		
	Power consumption	Refer to main label		
	Mass	3.8kg		
	External dimensions (W x H x D)	360 x 75 x 314 mm		
	Operating conditions	Temperature: 5°C to 35°C, Operation status: Horizontal		
	Operating humidity	5% to 85%		
[CD/DVD]	Laser	Semiconductor laser, wavelength 650 nm		
	Signal system	PAL 625/50, NTSC 525/60		
	Frequency response (audio)	200 Hz to 18 kHz		
	Signal-to-noise ratio (audio)	More than 70 dB (1 kHz, NOP, 20 kHz LPF/A-Filter)		
	Dynamic range (audio)	More than 70 dB		
	Harmonic distortion (audio)	1.0 % (1 kHz, at 12W position) (20 kHz LPF/A-Filter)		
[Video]	Video output	1.0 V (p-p), 75Ω , negative sync., RCA jack		
	S-video output	(Y) 1.0 V (p-p), 75Ω , negative sync., Mini DIN 4-pin x 1 (C) 0.3 V (p-p), 75Ω		
[Tuner]	[FM]	Tuning Range	87.5 - 108.0 MHz or 65.0 - 74.0 MHz, 87.5 - 108.0 MHz	
		Intermediate Frequency	10.7 MHz	
		Signal-to Noise Ratio	55 dB (Mono)	
	[AM [MW]]	Frequency Response	180-10,000 Hz	
		Tuning Range	522~1,611kHz, 530~1,610kHz	
		Intermediate Frequency	450 kHz	
[Amplifier]	Stereo mode	25W + 25W (6Ω at 1 kHz, THD 10 %)		
	Surround mode (* Depending on the sound mode settings and the source, there may be no sound output.)	Front: 25W + 25W (THD 10 %) Centre*: 25W Surround*: 25W + 25W (6Ω at 1 kHz, THD 10 %) Subwoofer*: 60W (8Ω at 70 Hz, THD 10 %)		
	Outputs	S-VIDEO MONITOR		
[Speakers]		Satellite Speaker	Passive Subwoofer	
	Type	1Way 1Speaker	1Way 1Speaker	
	Impedance	6Ω	8Ω	
	Frequency Response	130-20,000 Hz	50 -1,500 Hz	
	Sound Pressure Level	85 dB/W (1m)	82 dB/W (1m)	
	Rated Input Power	25 W	60 W	
	Max. Input Power	50 W	120 W	
	Net Dimensions (W x H x D)	89 x 89 x 90mm	170 x 350 x 333 mm	
Net Weight	0.4kg	4.3kg		
[Supplied Accessories]	<ul style="list-style-type: none"> • Speakers6 • AM loop antenna1 • Remote control1 • Speaker cables5 • FM antenna1 • Batteries (AAA)2 			

Designs and specifications are subject to change without notice.

SECTION 2. AUDIO PART

□ AUDIO TROUBLESHOOTING GUIDE

1. POWER SUPPLY CIRCUIT

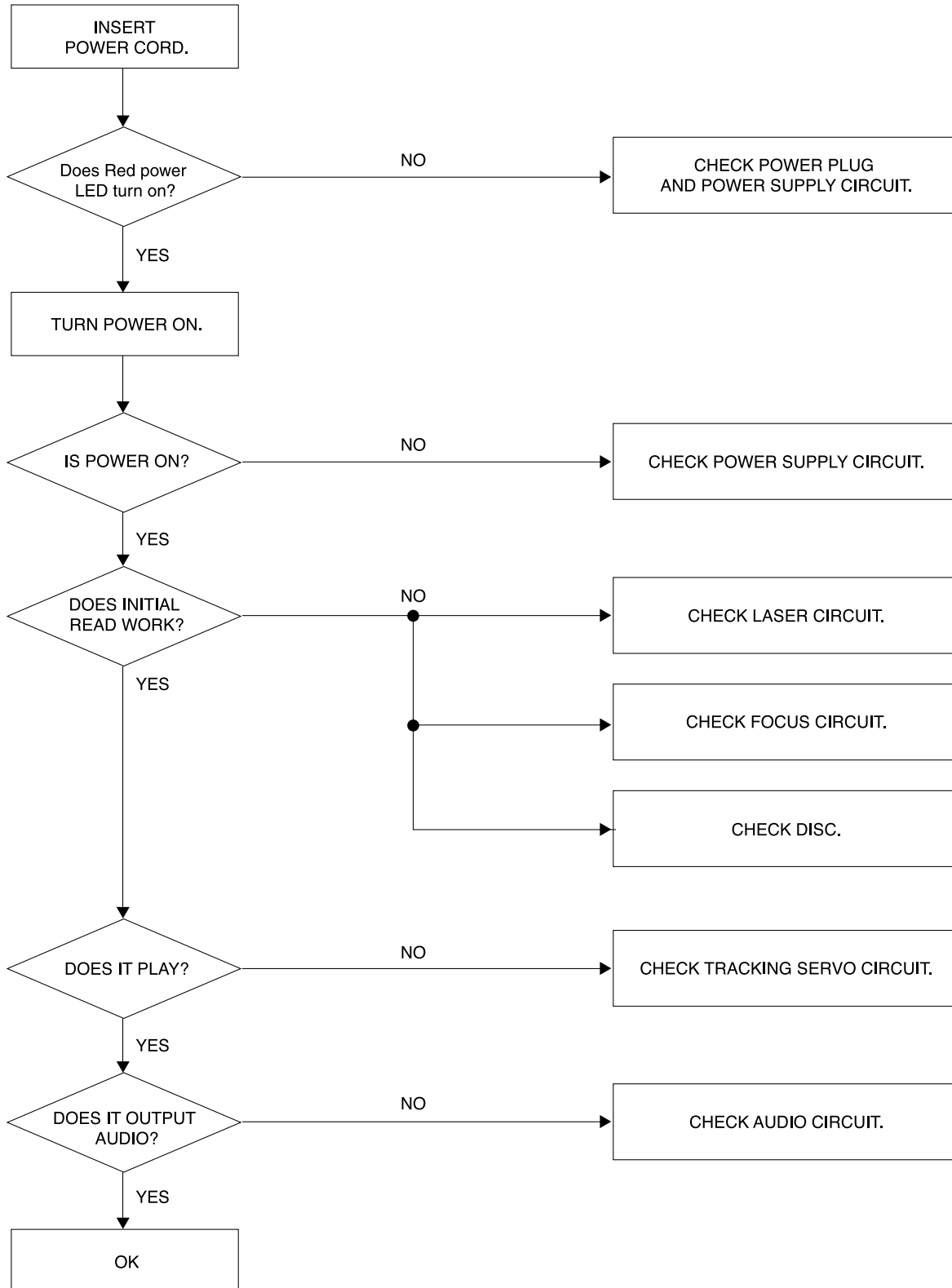

2. FRONT CIRCUIT (1/2)

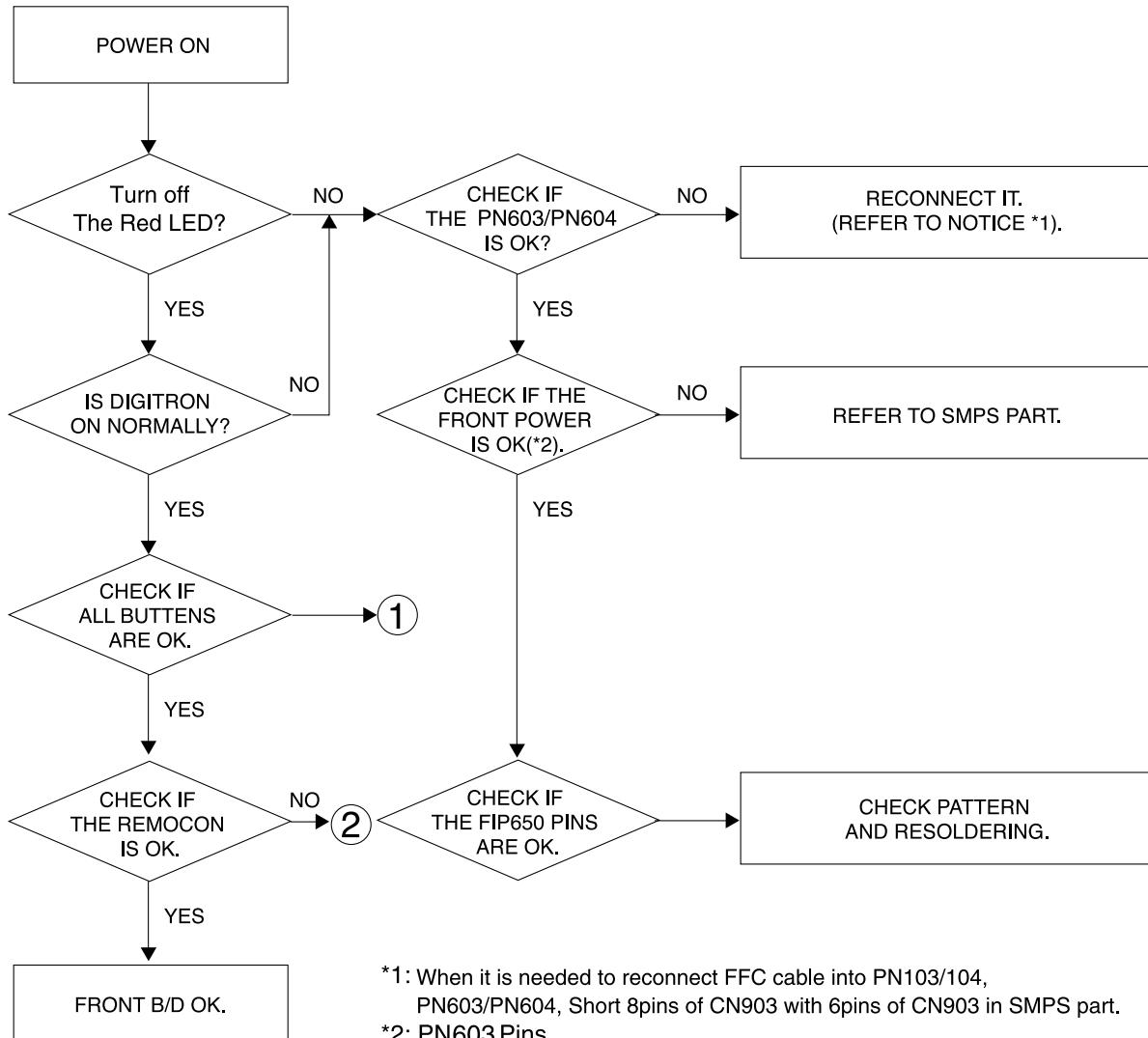

*1: When it is needed to reconnect FFC cable into PN103/104,
PN603/PN604, Short 8pins of CN903 with 6pins of CN903 in SMPS part.

*2: PN603 Pins.
 PIN1 : -32.4
 PIN2 : -27.5
 PIN3 : -23.7
 PIN4 : -23.7
 PIN11 : -5.0

MEMO

□ BLOCK DIAGRAM

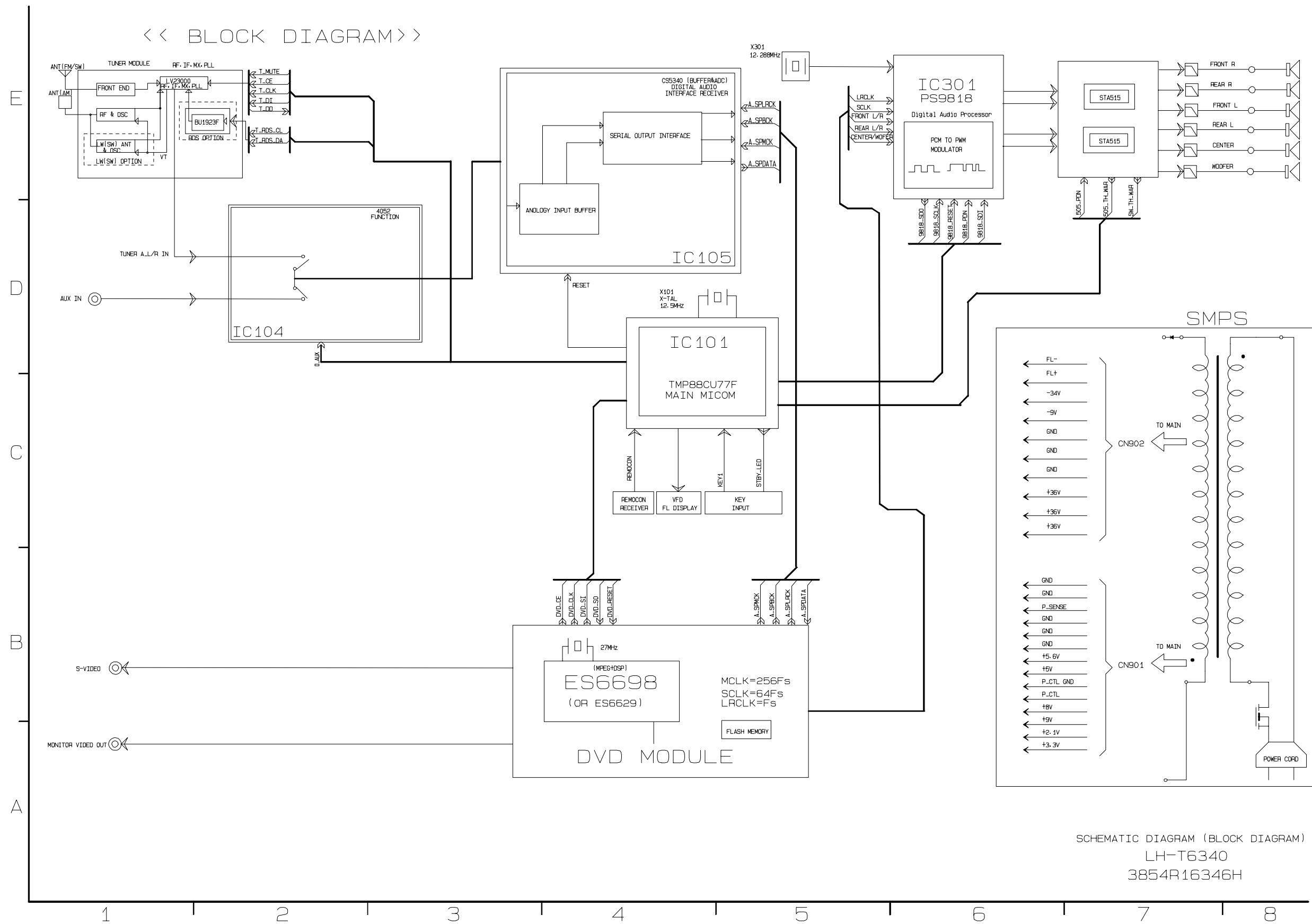

SCHEMATIC DIAGRAMS

POWER SCHEMATIC DIAGRAM

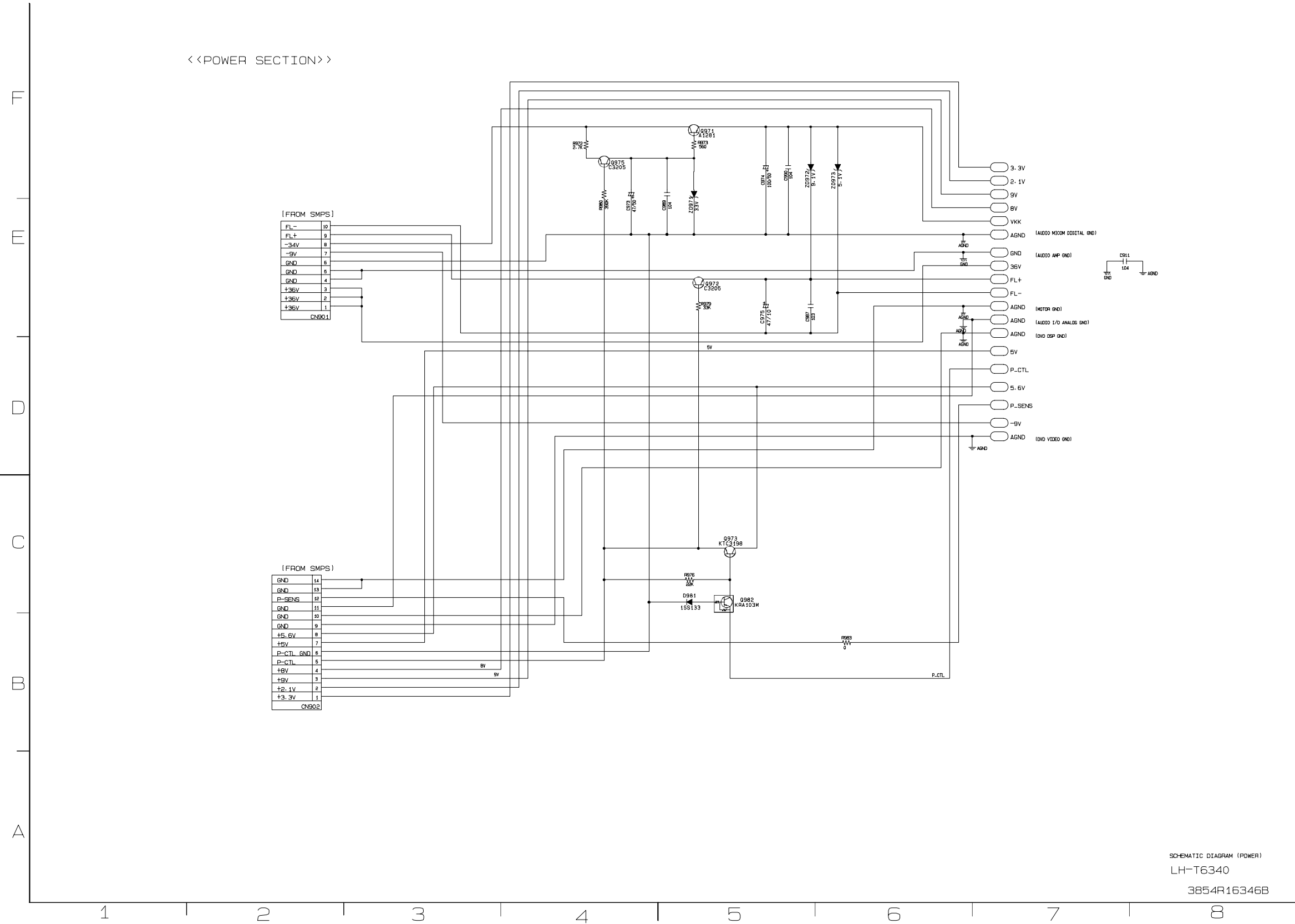

SCHEMATIC DIAGRAM (POWER)
LH-T6340
3854R16346B

• FRONT SCHEMATIC DIAGRAM

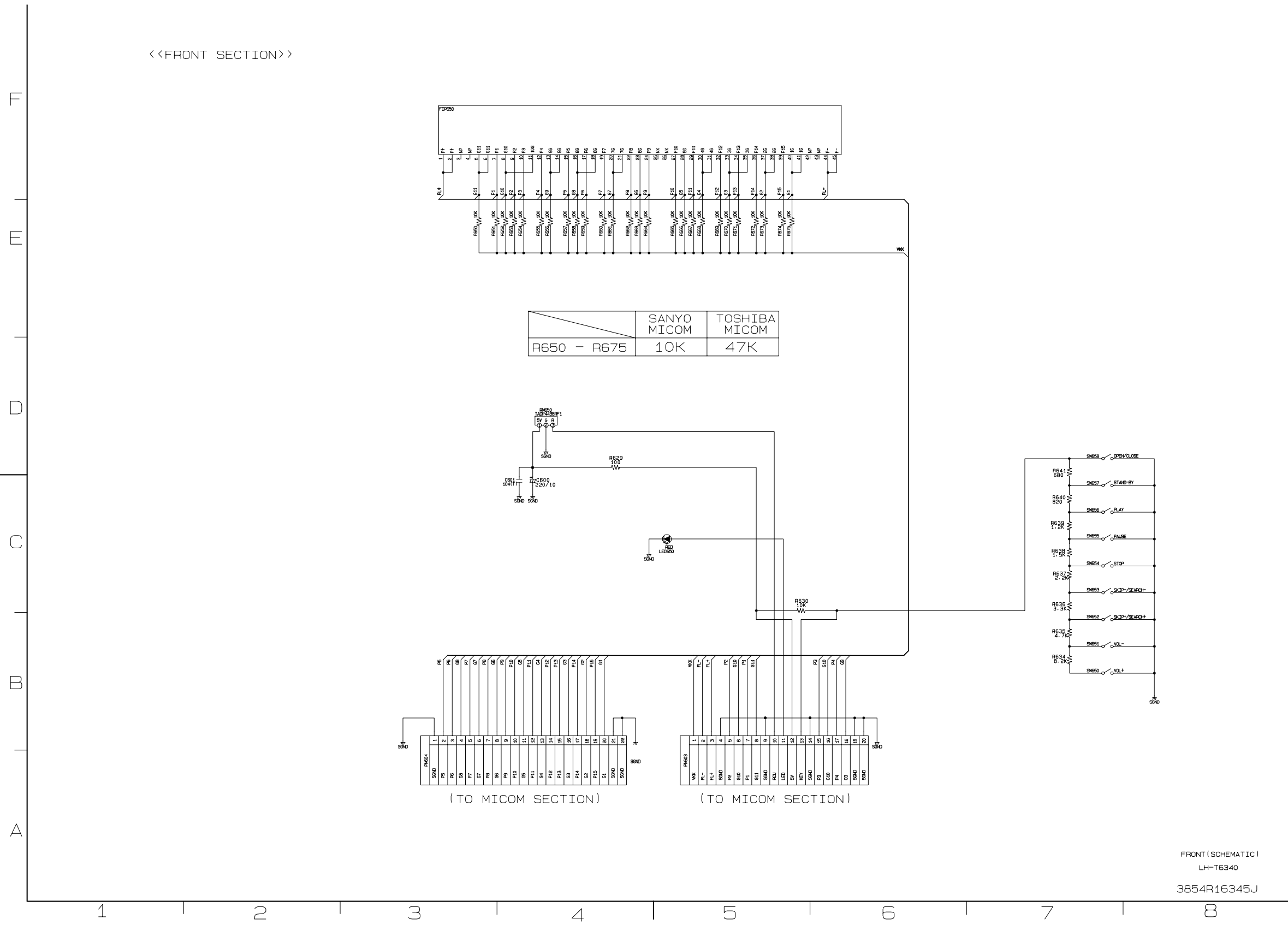

FRONT (SCHEMATIC)
LH-T6340
3854R16345J

• DSP& SCHEMATIC DIAGRAM

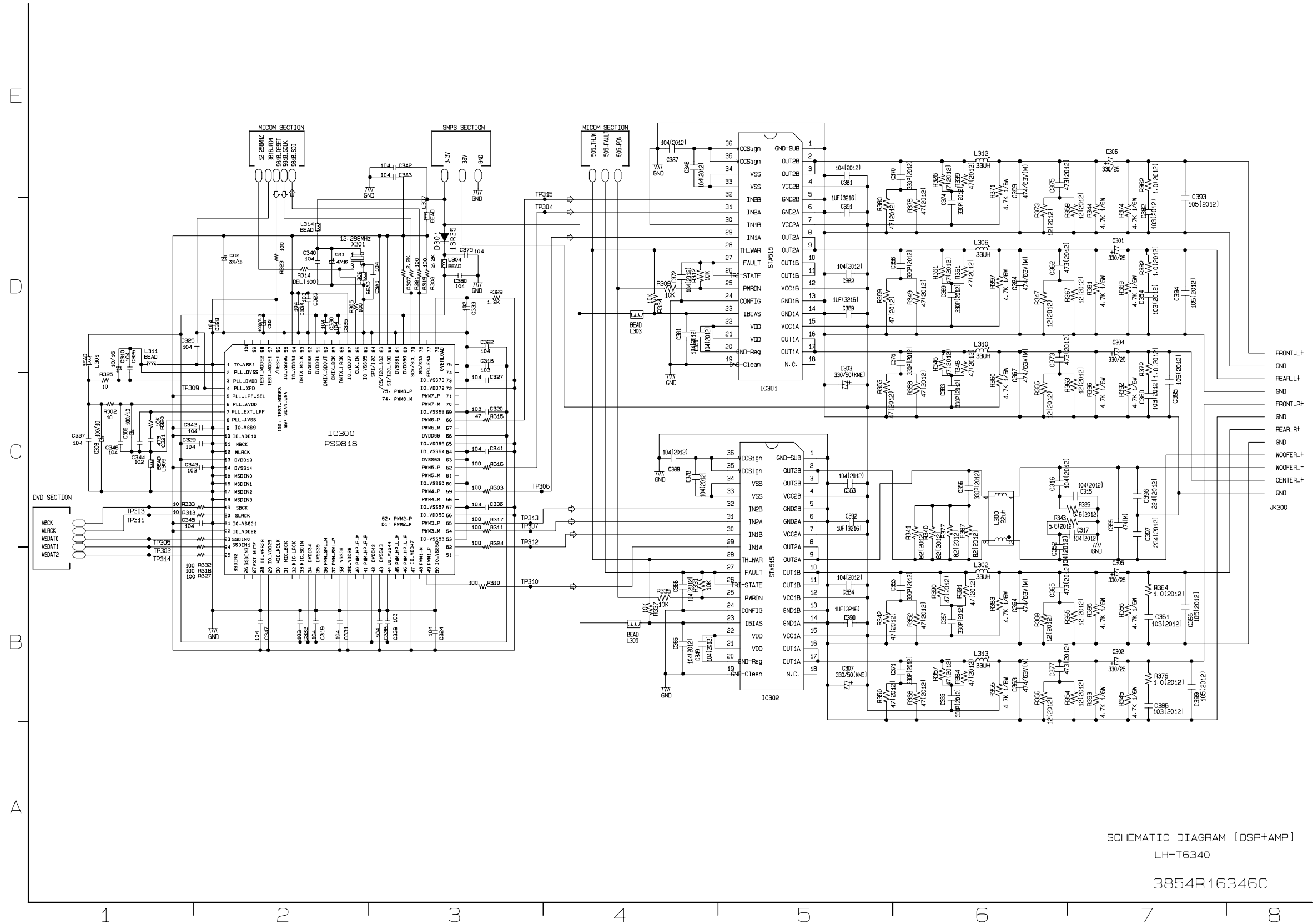

SCHEMATIC DIAGRAM [DSP+AMP]
LH-T6340
3854R16346C

• SMPS-NARROW&WIDE SCHEMATIC DIAGRAM

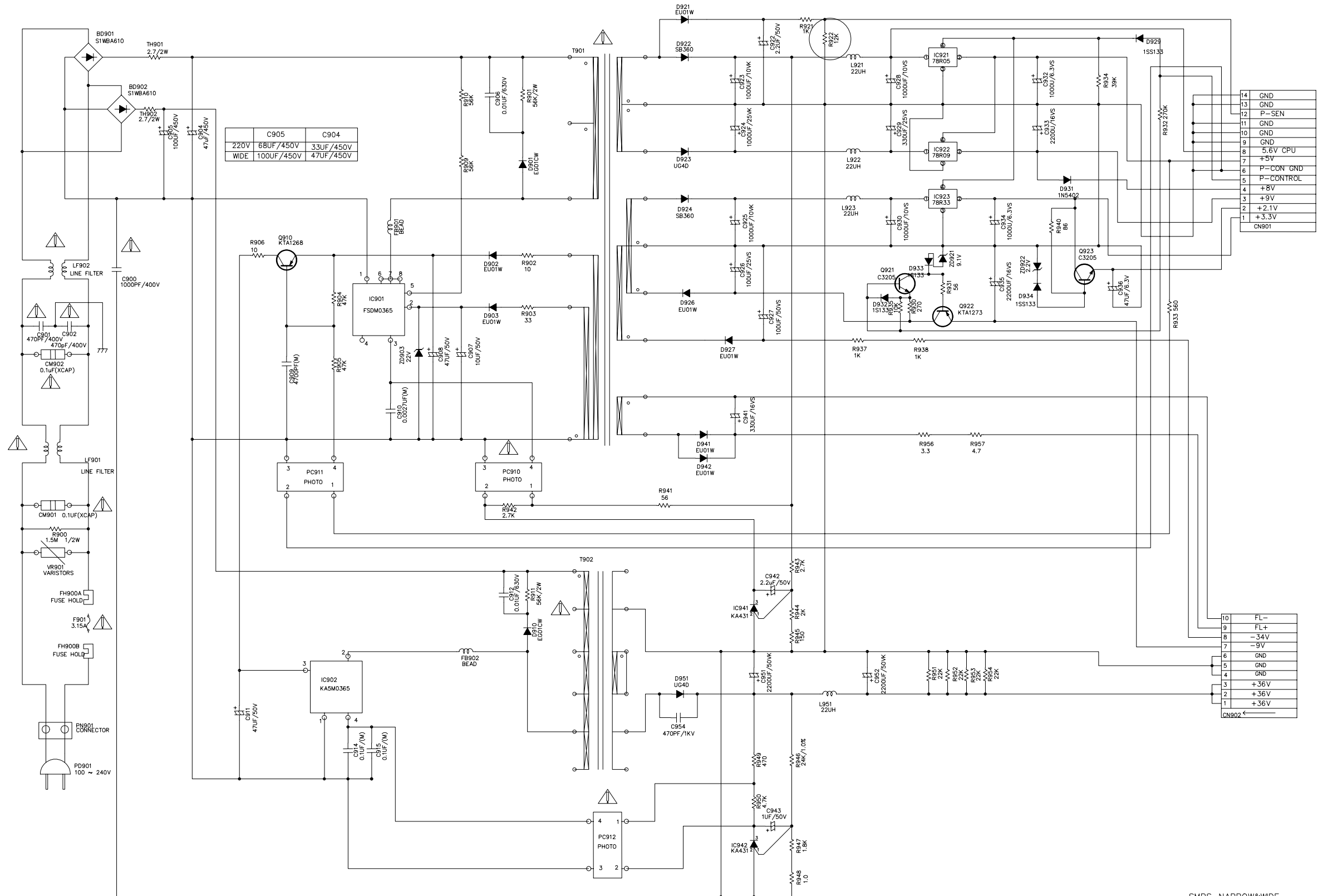

SMPS-NARROW&WIDE
LH-T6340
VD 3854R16340B

WIRING DIAGRAM

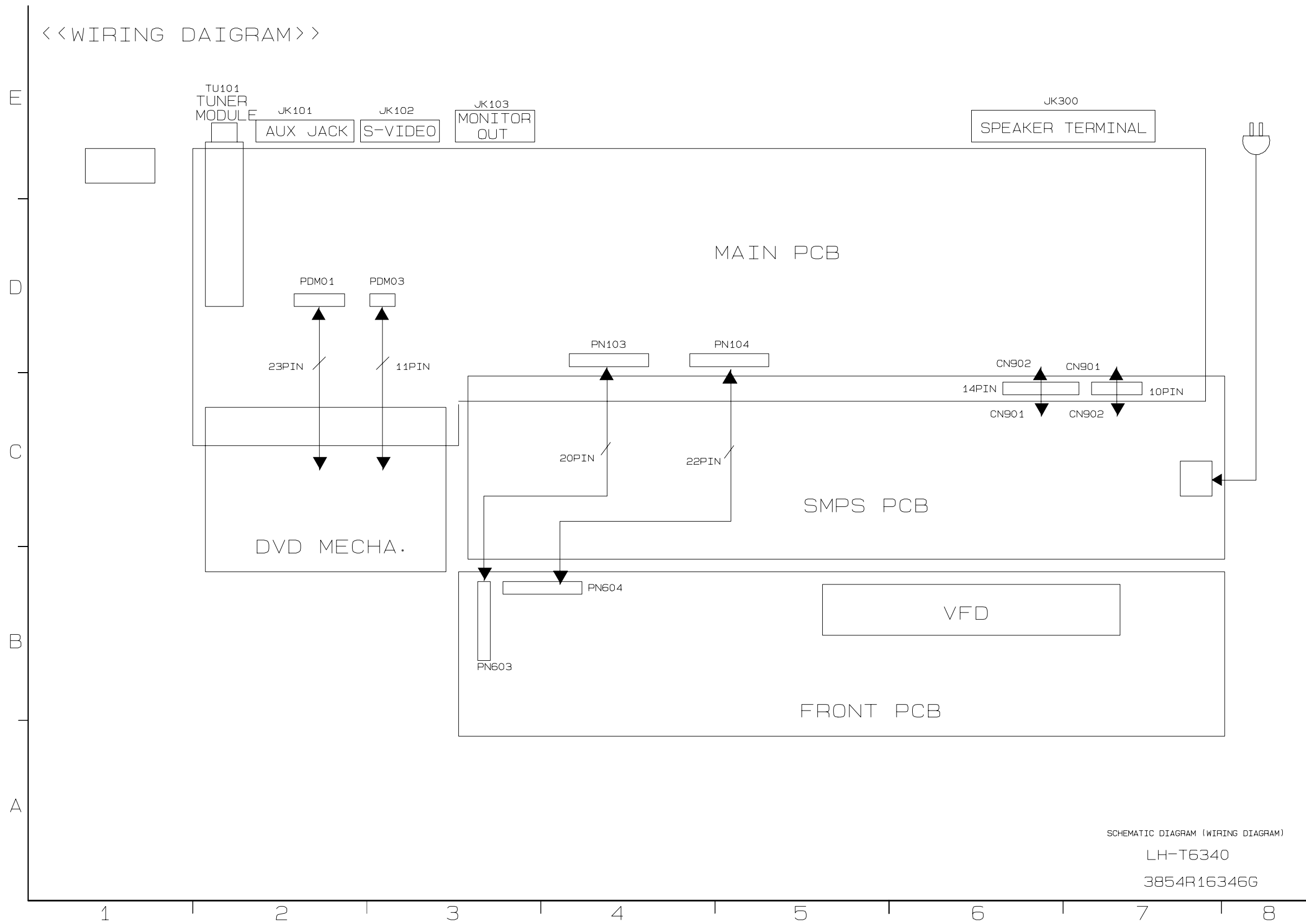

SCHEMATIC DIAGRAM (WIRING DIAGRAM)

LH-T6340

3854R16346G

PRINTED CIRCUIT BOARD DIAGRAMS

MAIN/DVD P.C. BOARD DIAGRAM (BOTTOM)

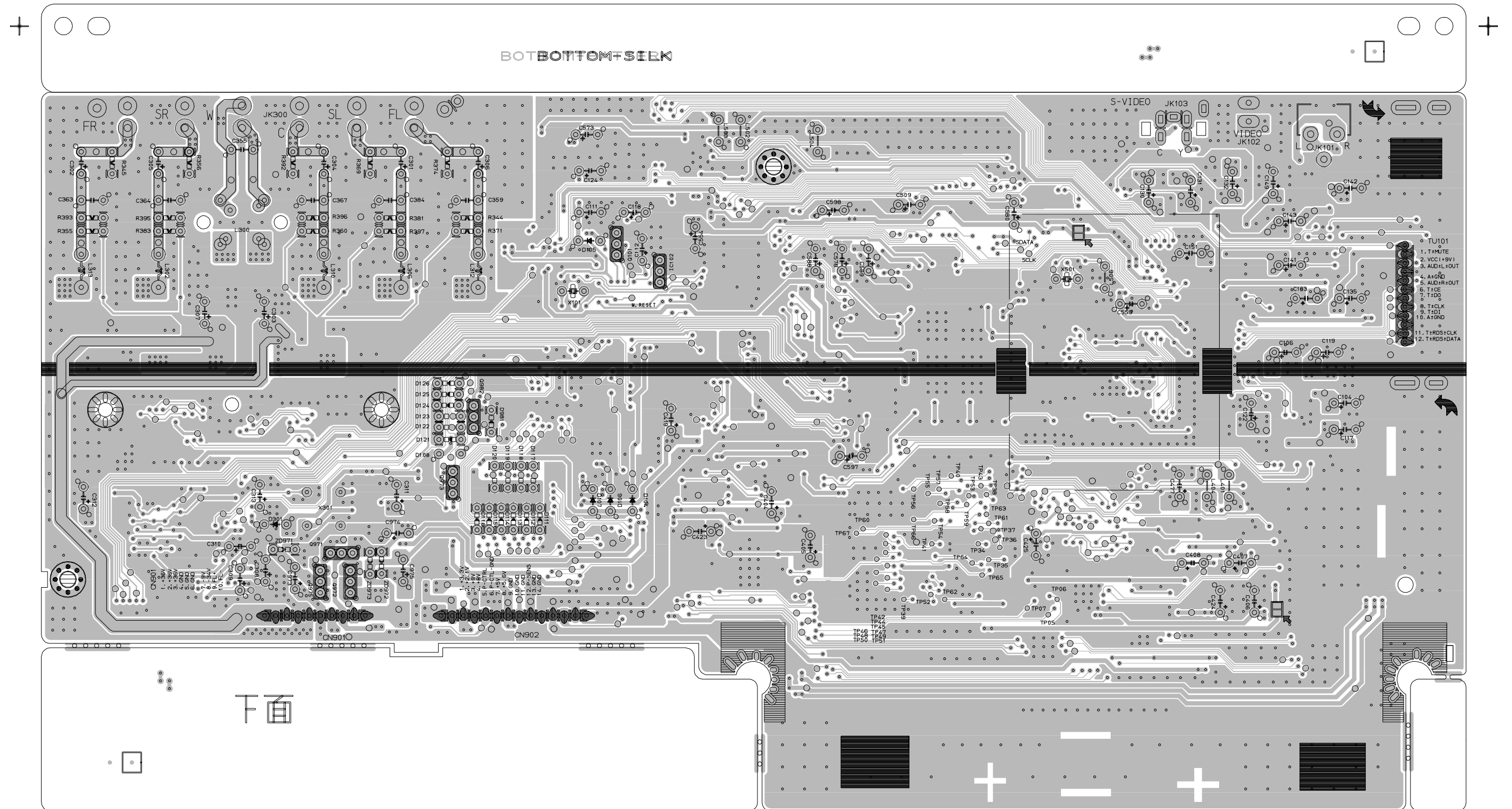

• MAIN/DVD P.C. BOARD DIAGRAM (TOP)

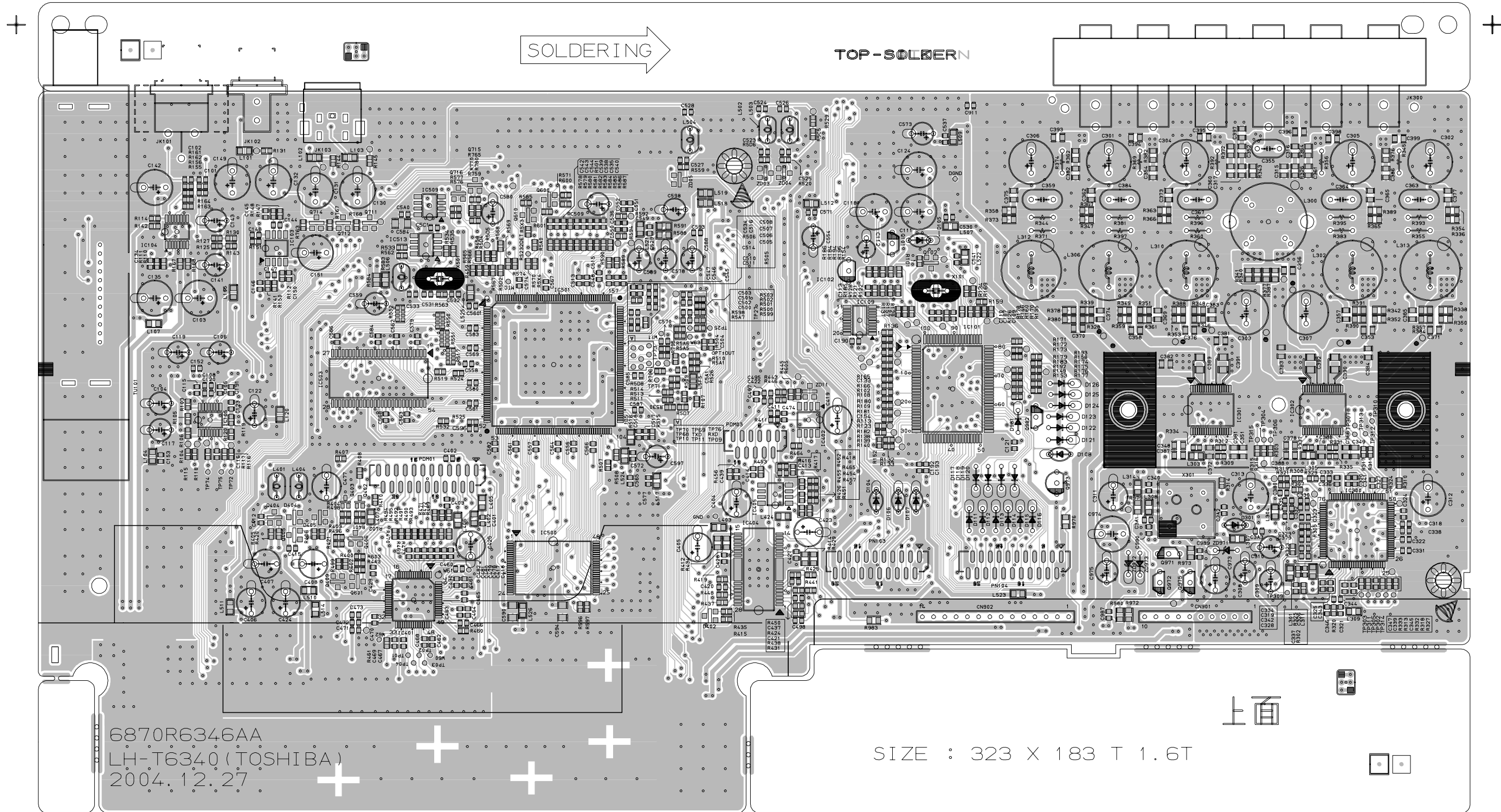

• FRONT P.C. BOARD (BOTTOM)

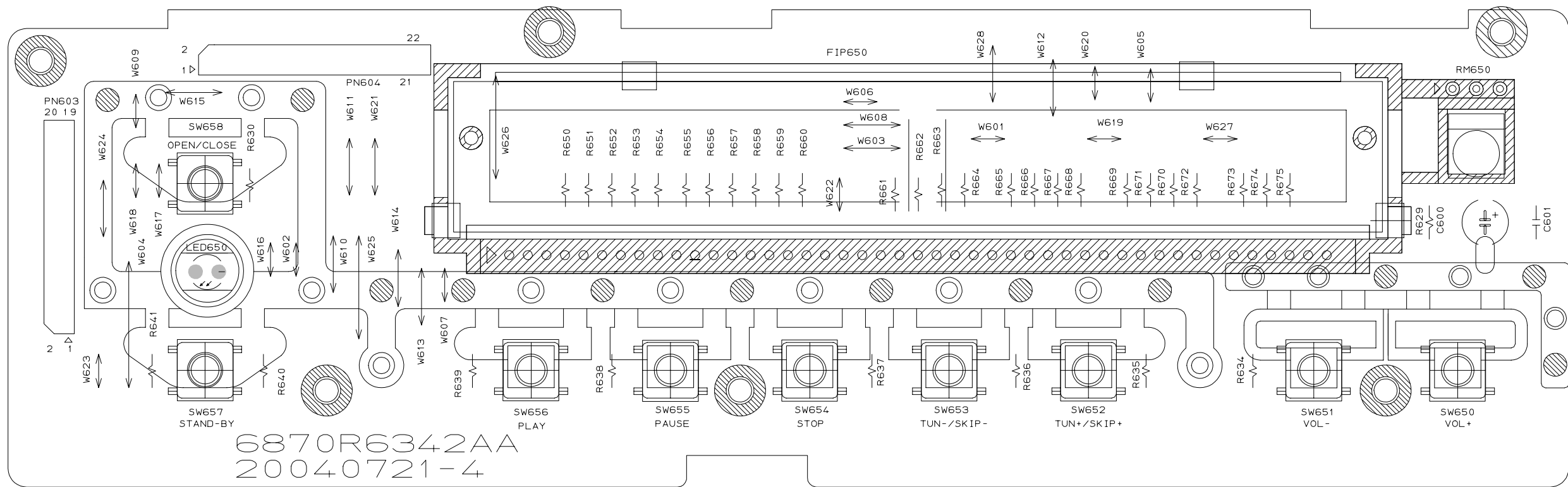

• FRONT P.C. BOARD (TOP)

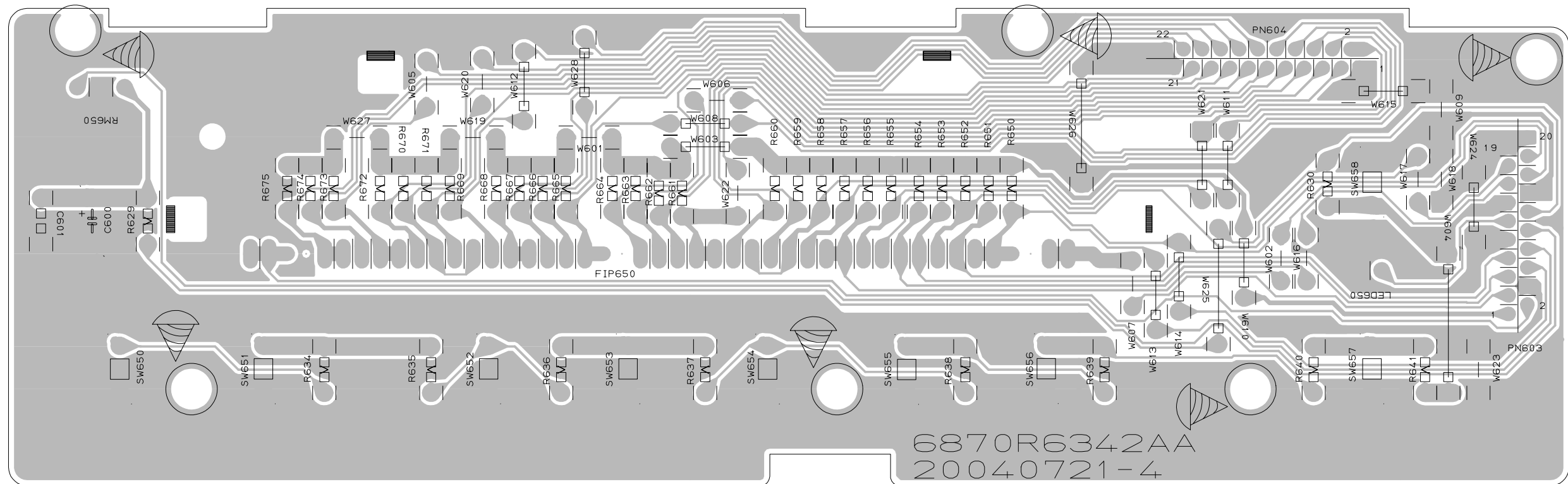

• SMPS P.C. BOARD

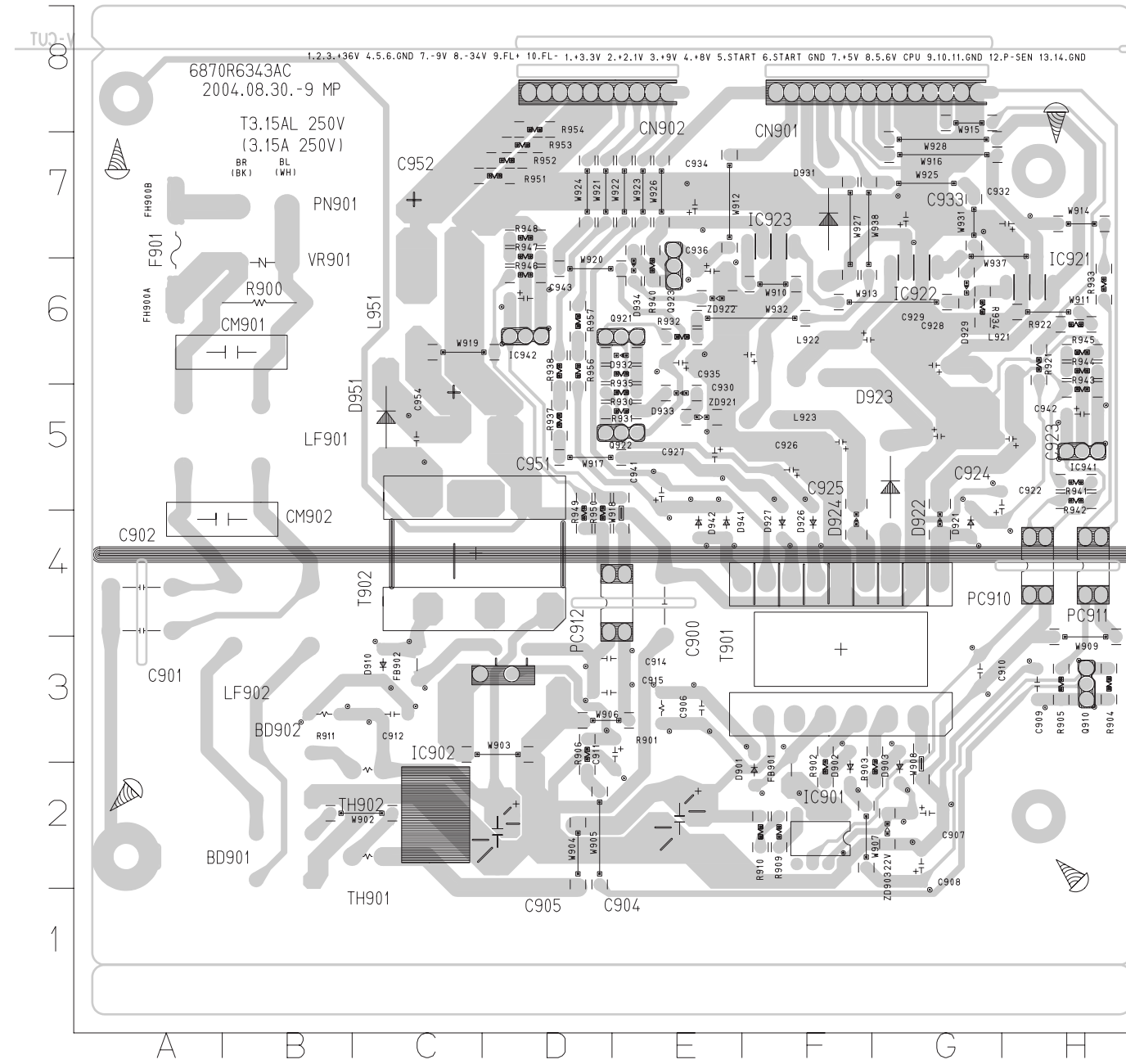

SECTION 3. DVD PART

TROUBLESHOOTING GUIDE

1. Test & debug flow

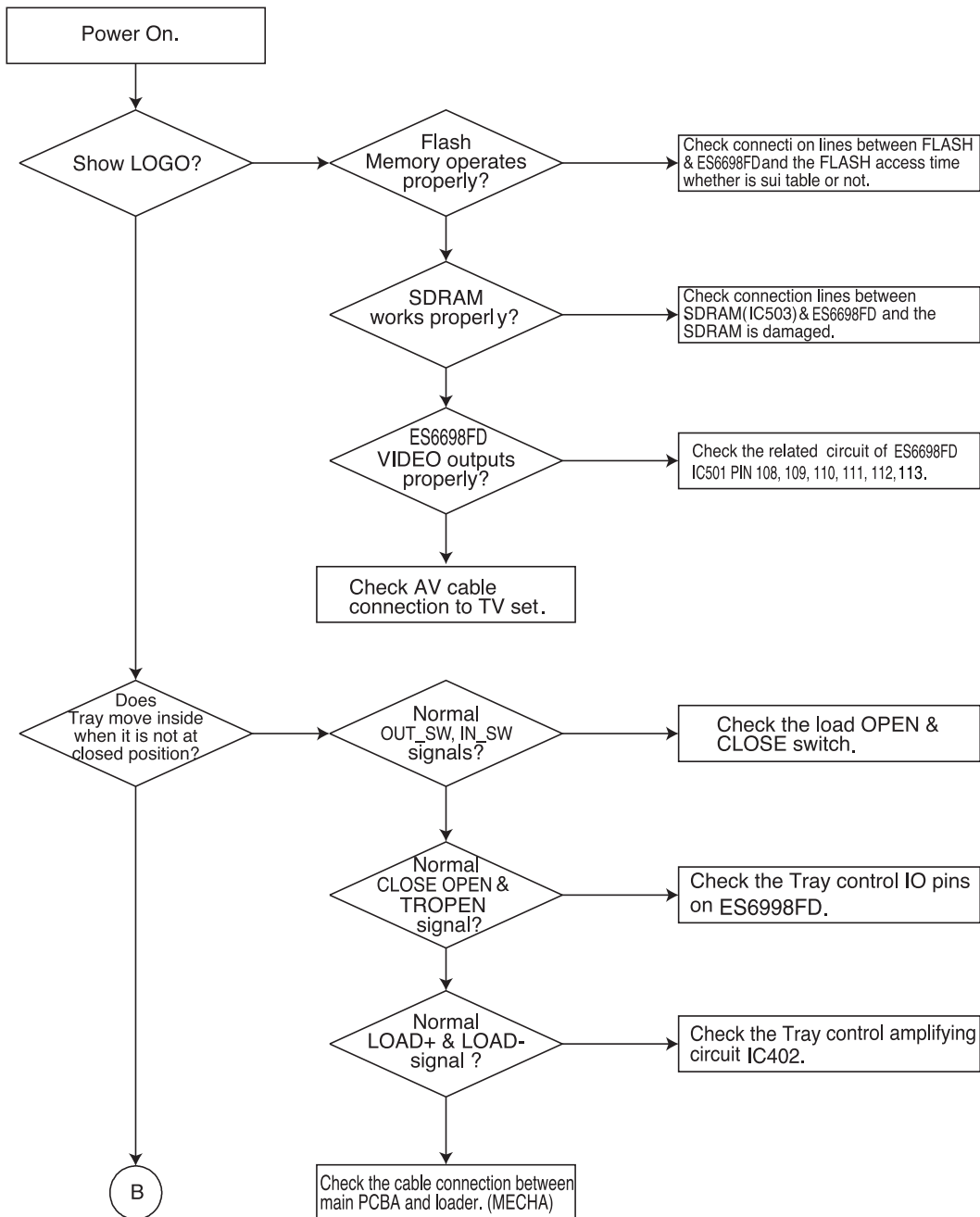

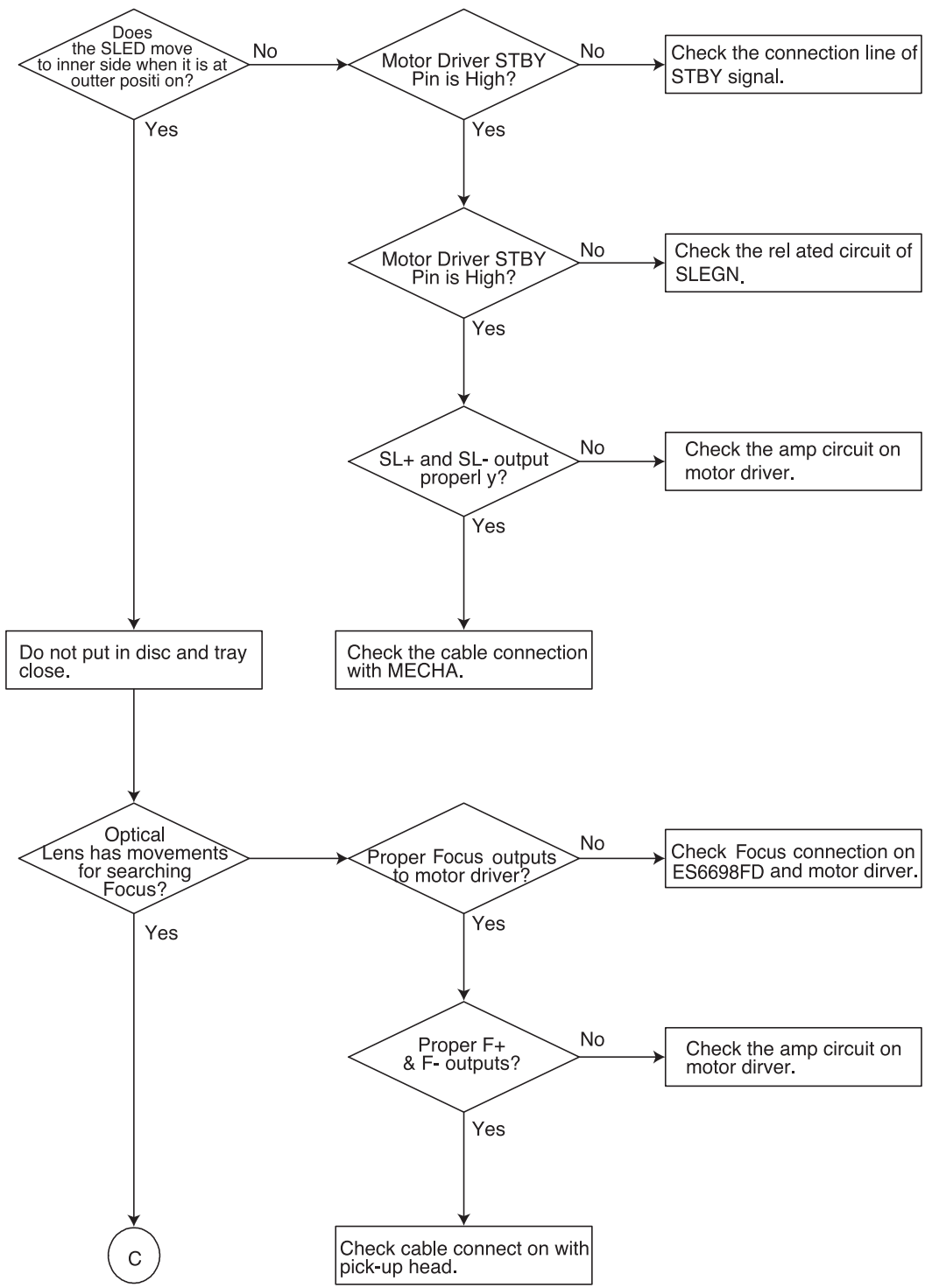

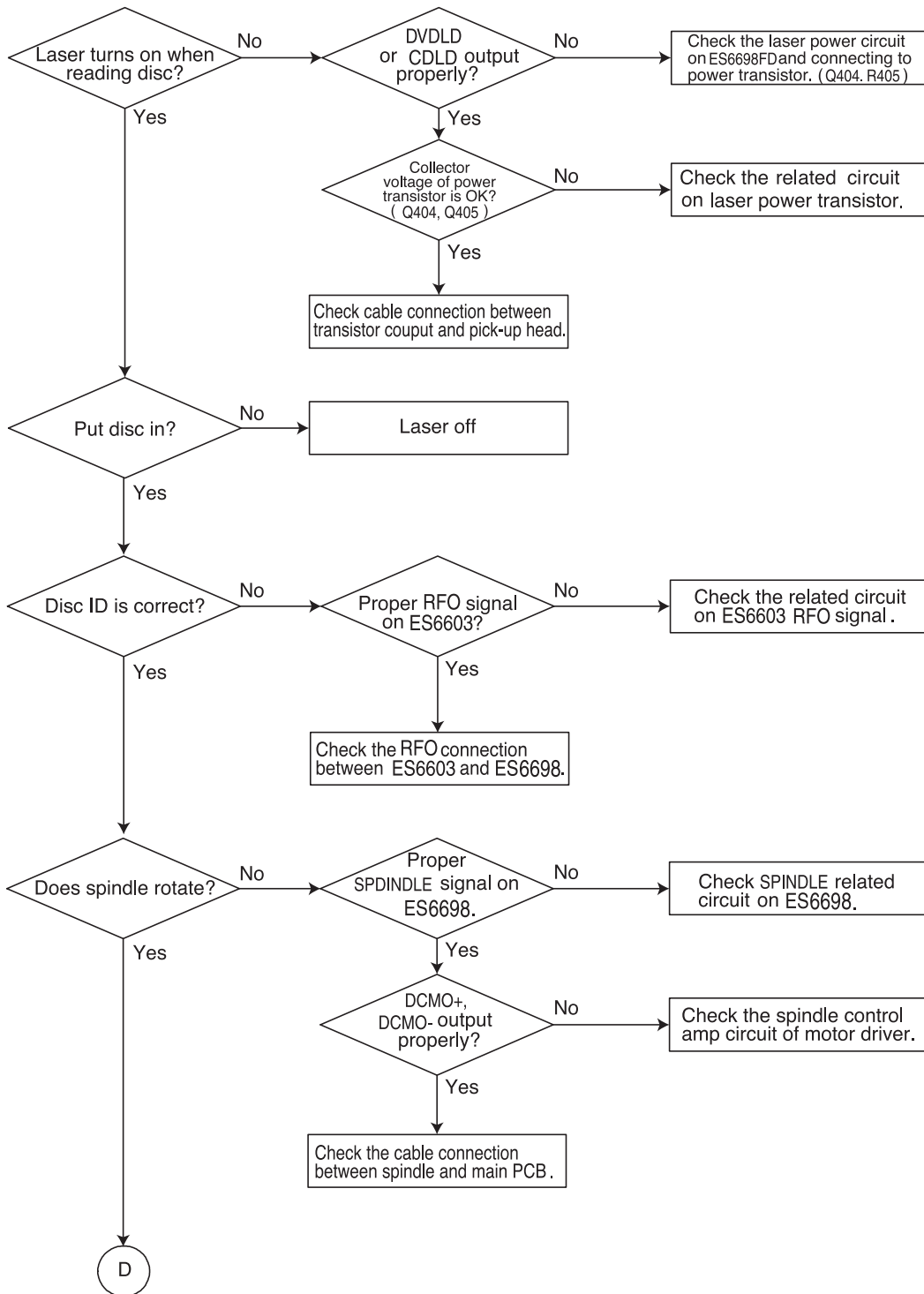

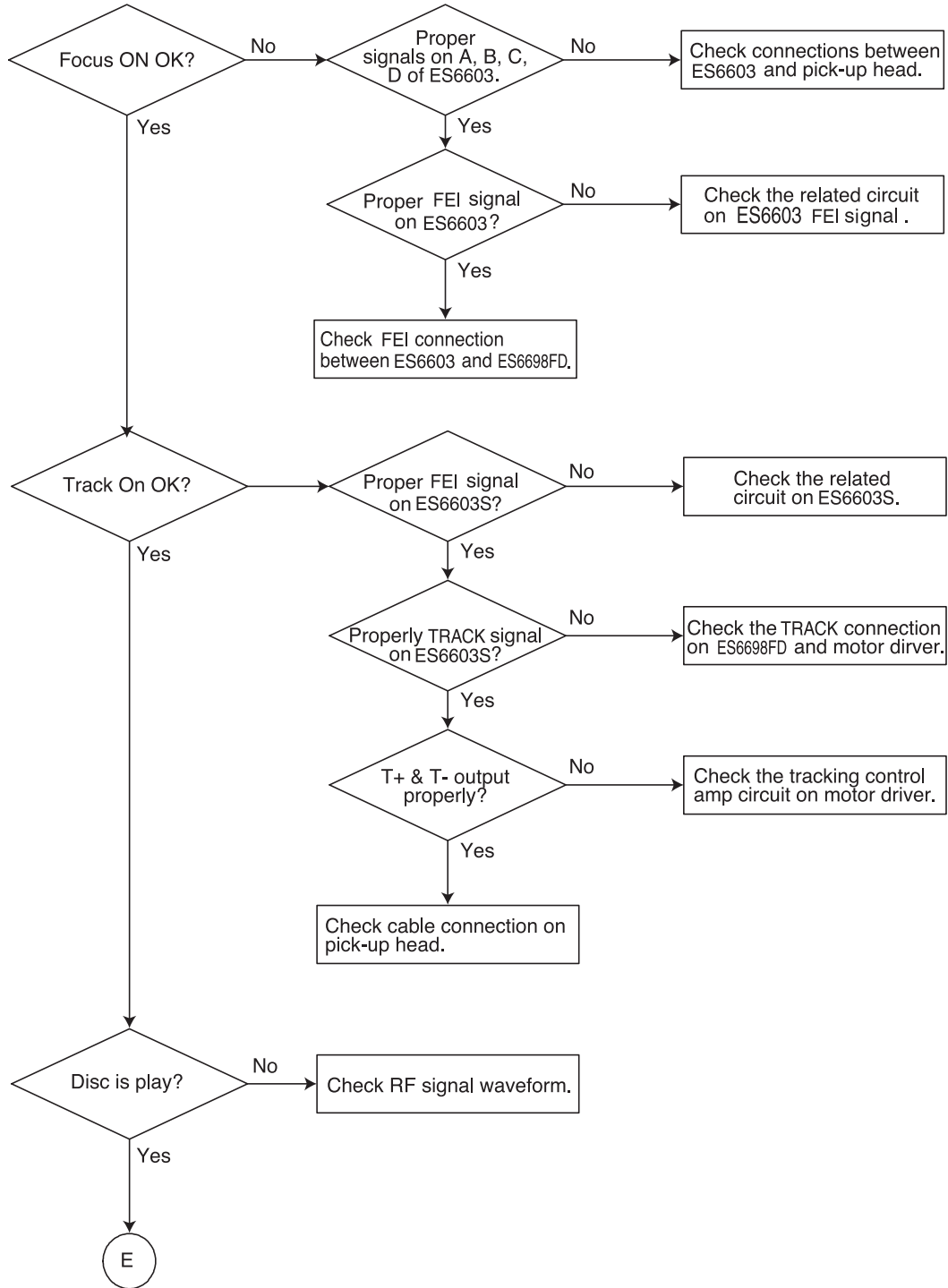

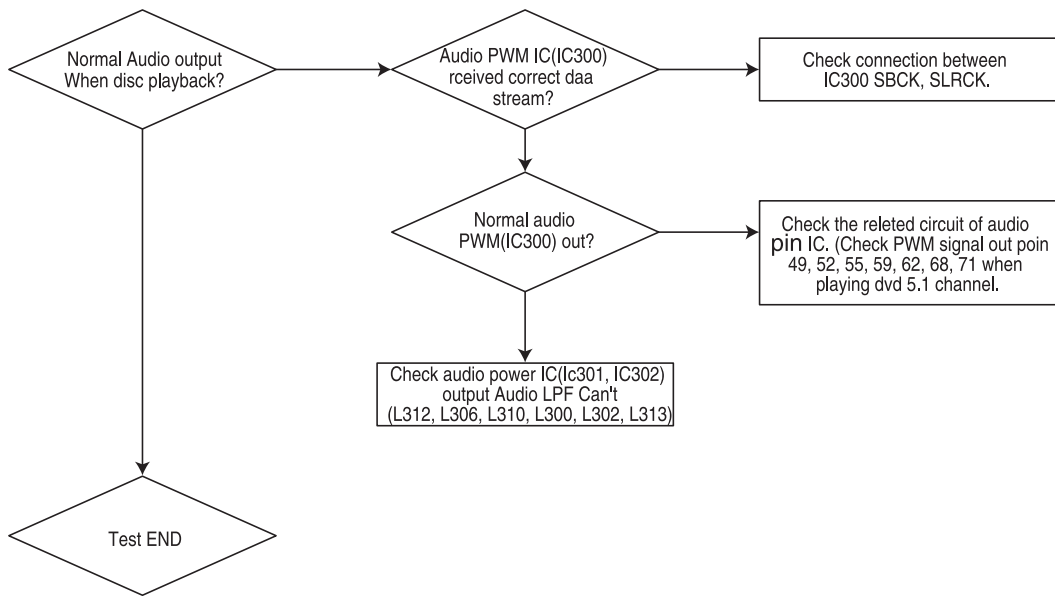

DVD SCHEMATIC DIAGRAMS

DVD MPEG & DSP SCHEMATIC DIAGRAM

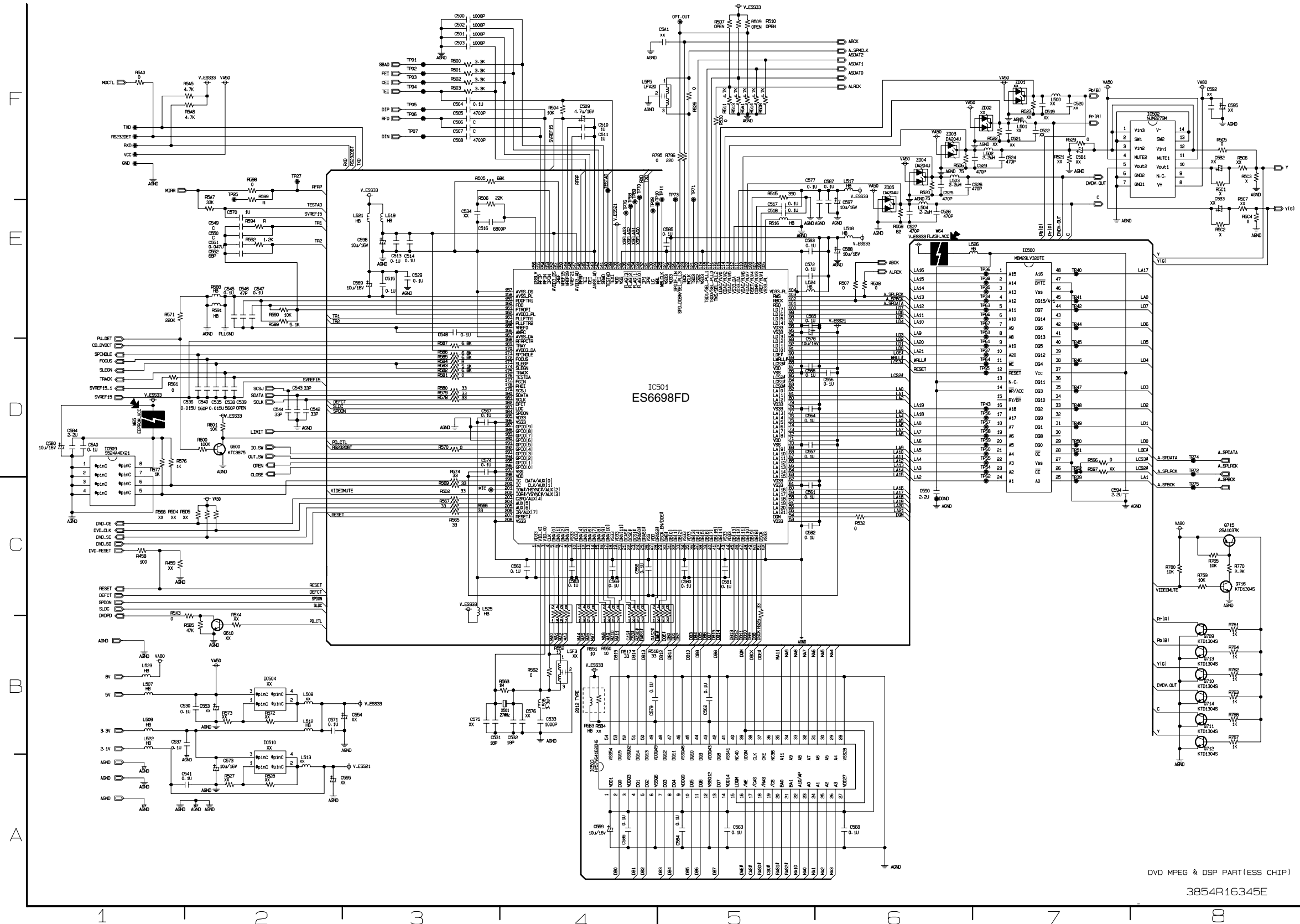

DVD MPEG & DSP PART(ESS CHIP)

3854R16345E

DVD RF SCHEMATIC DIAGRAM

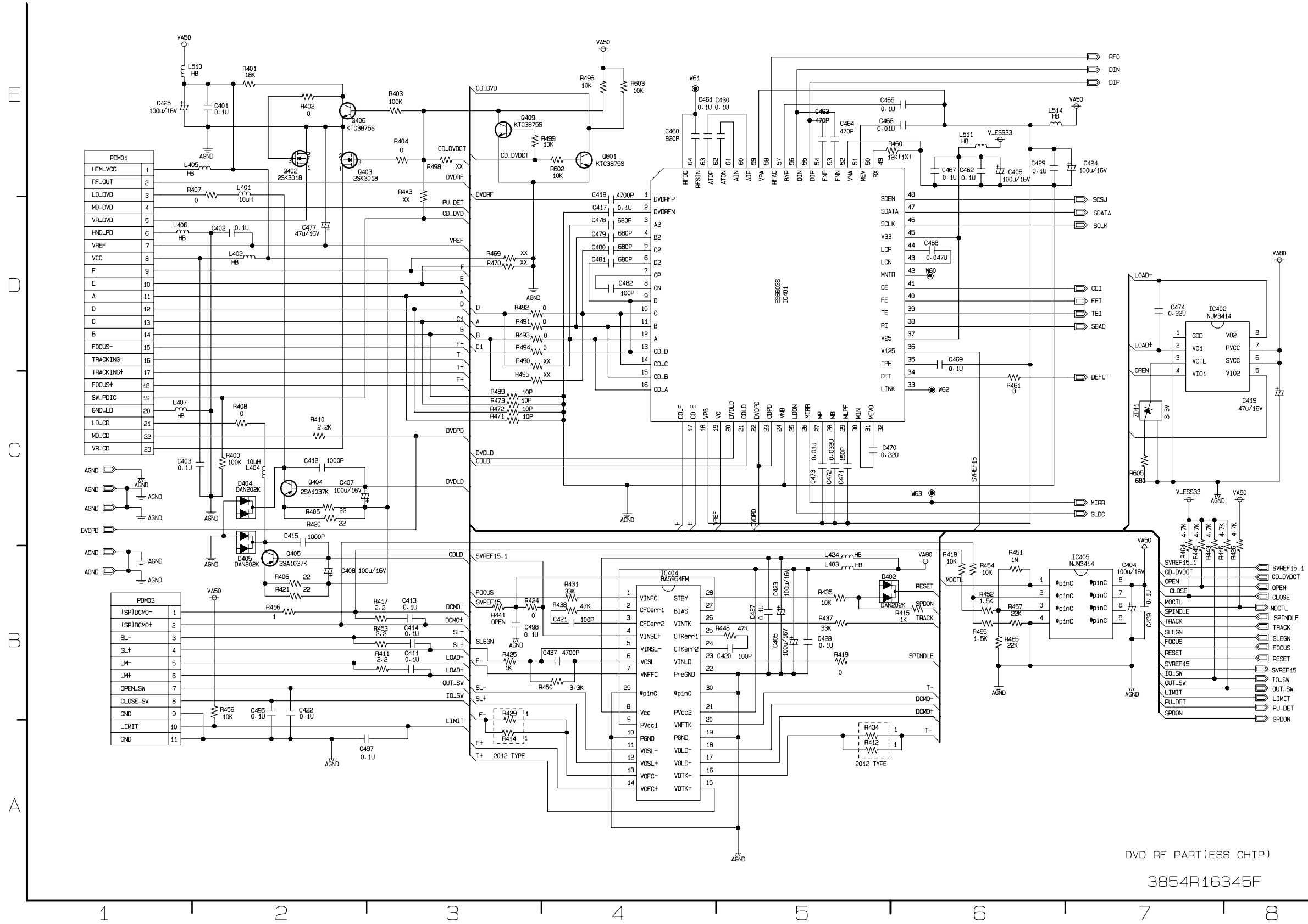

DVD RF PART (ESS CHIP)

3854R16345F

SECTION 4. EXPLODED VIEWS

CABINET AND MAIN FRAME SECTION

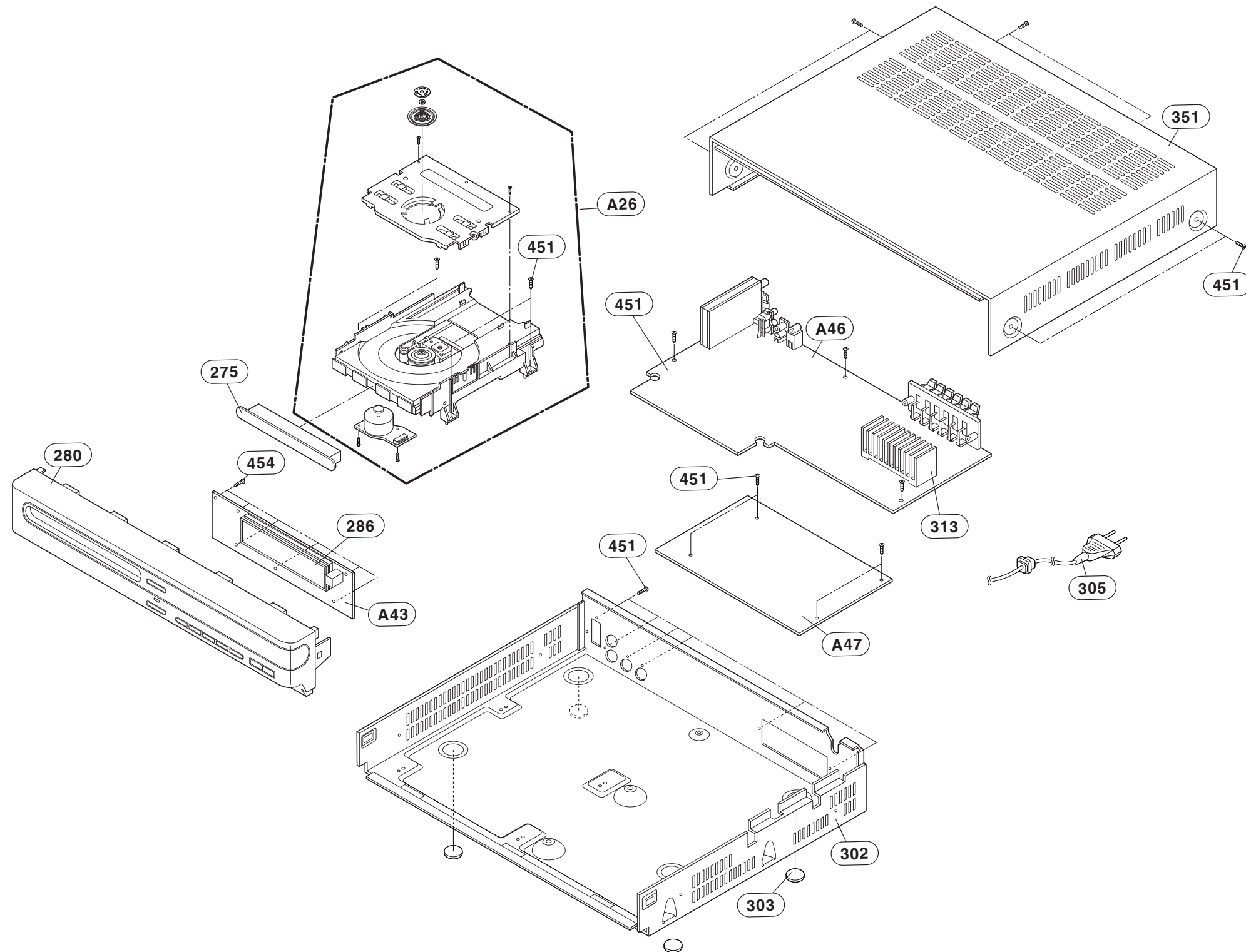

• DECK MECHANISM EXPLODED VIEW

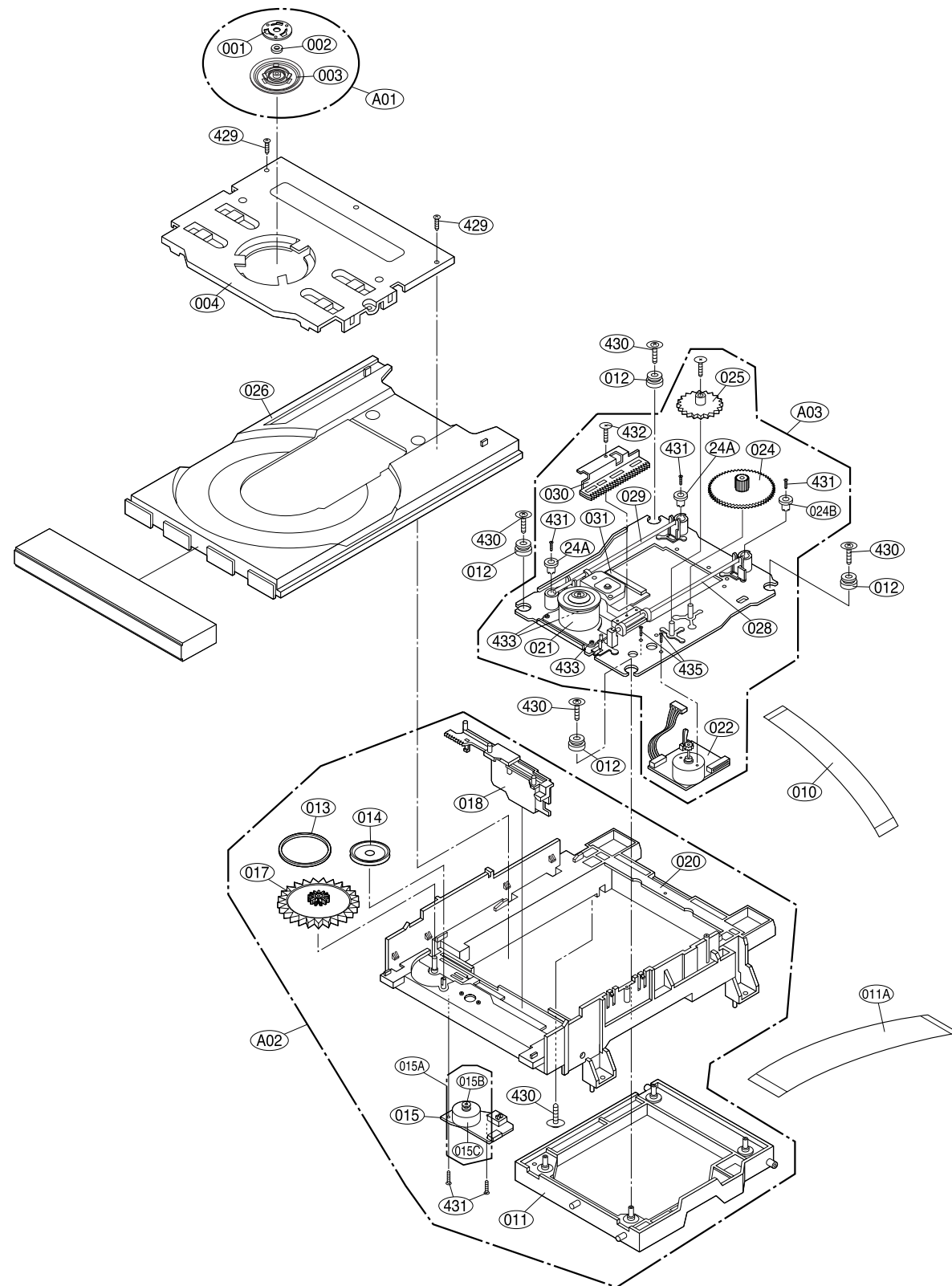

LOCA. NO.	PART NO.	DESCRIPTION	SPECIFICATION
A26	6721RJ0856E	DECK ASSEMBLY,AUDIO	DECK/MECHA DP-7T(HZ)-ESS -(M:M
A01	4861R-0016D	CLAMP ASSEMBLY	DECK/MECHA DISC DP-7C(7A) -HZ
A02	3041R-M040A	BASE ASSEMBLY	MAIN DP-7T-HZ
A03	3041R-M061D	BASE ASSEMBLY	SLED DP-7A-HZ ESS (M: MITSUMI
001	3300R-0547A	PLATE	CLAMP
002	5016H-1016B	MAGNET	CLAMP(LDM-R608,10*5,1*1.5T)
003	4860R-0021A	CLAMP	UPPER DP7
004	4930R-0402A	HOLDER	CLAMP DP-7A
010	6850R-GK22Z	CABLE,FLAT	P=1.0 FFC UL2896(0.05X0.65) 11
011	3210R-M002A	FRAME	UP/DOWN MOLD DP7C
011A	6850R-JW16B	CABLE,FLAT	P=1.0 FFC UL2896(0.035X0.7) 23
012	5040R-0075D	RUBBER	DAMPER DP7 (YAMAUCHI 30)
013	4400R-0006B	BELT	DECK/MECHA DP2-5, DP7C,DP7A OT
014	4470R-0055A	GEAR	PULLEY
015	6871RJ4415A	PWB(PCB) ASSEMBLY,JACK	PWB(PCB) TOTAL LOADING-HZ
015A	4681R-1023G	MOTOR ASSEMBLY	DECK/MECHA LOADING-HZ
015B	4560R-0008A	PULLEY	MOTOR
015C	4680R-E010A	MOTOR(MECH)	FEEDING BCZ3B51 SANKYO FOR DP7
017	4470R-0056A	GEAR	LOADING
018	4974R-0023A	GUIDE	UP/DOWN
020	3040R-D005A	BASE	MAIN DP-7T MOLD (SLIM)
021	4680R-C011A	MOTOR(MECH)	SPINDLE JCL9B68 SANKYO FOR COM
022	4681R-0034D	MOTOR ASSEMBLY	DECK/MECHA FEEDING DP-7C(7A) -
024	4470R-0131A	GEAR	PINION DP7C
024A	5006R-0044A	CAP	SKEW-T DP7C
024B	5006R-0043A	CAP	SKEW DP7C
025	4470R-0130A	GEAR	MIDDLE DP7C
026	3390R-0026A	TRAY	DVD DP-7T MOLD DISC
028	4370R-0082B	SHAFT	DECK/MECHA PU R DP-7C OTHER
029	4370R-0082A	SHAFT	PU DP-7C
030	4471R-0013D	GEAR ASSEMBLY	DECK/MECHA RACK DP-7C(7A) -HZ
031	6716DPH005B	PICK UP,DVD	PVR-502W R52 0219 MITSUMI PLAY
429	1SZZR-0012A	SCREW,DRAWING	B-TITE
430	1SZZH-1003A	SCREW,DRAWING	+ D2.0 6MM SWRCH16A/NIY 4.5MM
431	1SZZH-1007B	SCREW,DRAWING	+ D2.0 6MM SWRCH16A/ZNBK 4MM 1
432	1SZZR-0023B	SCREW,DRAWING	+ 1 D1.7 L6.0 SWRCH16A/FZY RAC
433	1SZZR-0050A	SCREW,DRAWING	+ 1 D2.0 L4.5 SWRCH16A/ZNY S-T
435	1SZZR-0011A	SCREW,DRAWING	MACHINE

SECTION 5. SPEAKER SECTION

□ MODEL : LHS-T6240T

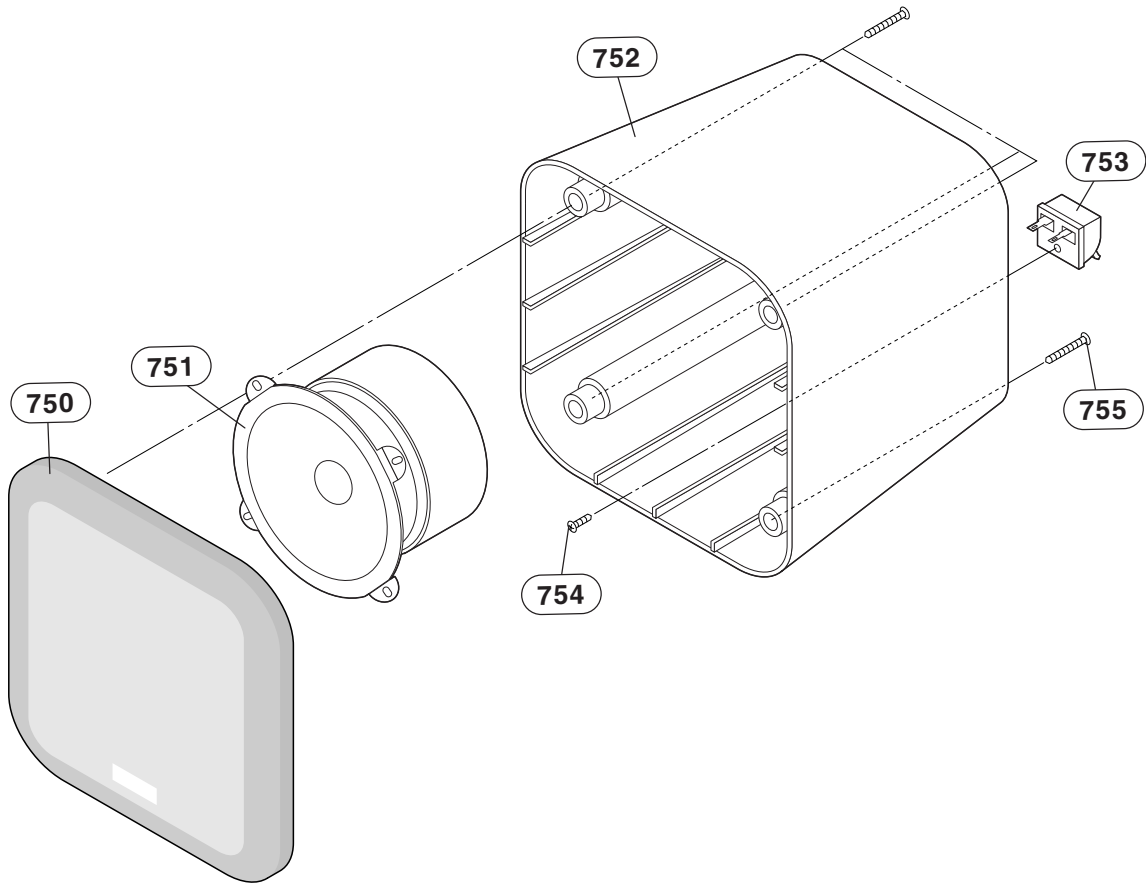

□ MODEL : LHS-T6240W

