

# [CONTENTS]

## **SECTION 1. GENERAL**

- SERVICING PRECAUTIONS ..... 1-2
- ESD PRECAUTIONS ..... 1-4
- SPECIFICATIONS ..... 1-5

## **SECTION 2. AUDIO PART**

- AUDIO TROUBLESHOOTING GUIDE ..... 2-1
- BLOCK DIAGRAM ..... 2-4
- SCHEMATIC DIAGRAMS ..... 2-6
- WIRING DIAGRAM ..... 2-20
- PRINTED CIRCUIT DIAGRAMS ..... 2-22

## **SECTION 3. DVD & AMP PART**

- ELECTRICAL TROUBLESHOOTING GUIDE ..... 3-1
- DVD PART SCHEMATIC DIAGRAMS ..... 3-22

## **SECTION 4. EXPLODED VIEWS ..... 4-1**

## **SECTION 5. SPEAKER PART ..... 5-1**

## **SECTION 6. REPLACEMENT PARTS LIST ..... 6-1**

# SECTION 1. GENERAL

## SERVICING PRECAUTIONS

### NOTES REGARDING HANDLING OF THE PICK-UP

#### 1. Notes for transport and storage

- 1) The pick-up should always be left in its conductive bag until immediately prior to use.
- 2) The pick-up should never be subjected to external pressure or impact.

Storage in conductive bag

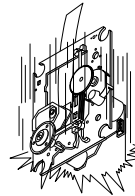
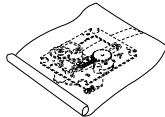

Drop impact

#### 2. Repair notes

- 1) The pick-up incorporates a strong magnet, and so should never be brought close to magnetic materials.
- 2) The pick-up should always be handled correctly and carefully, taking care to avoid external pressure and impact. If it is subjected to strong pressure or impact, the result may be an operational malfunction and/or damage to the printed-circuit board.
- 3) Each and every pick-up is already individually adjusted to a high degree of precision, and for that reason the adjustment point and installation screws should absolutely never be touched.
- 4) Laser beams may damage the eyes!  
Absolutely never permit laser beams to enter the eyes!  
Also NEVER switch ON the power to the laser output part (lens, etc.) of the pick-up if it is damaged.

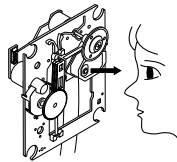

NEVER look directly at the laser beam, and don't let contact fingers or other exposed skin.

#### 5) Cleaning the lens surface

If there is dust on the lens surface, the dust should be cleaned away by using an air bush (such as used for camera lens). The lens is held by a delicate spring. When cleaning the lens surface, therefore, a cotton swab should be used, taking care not to distort this.

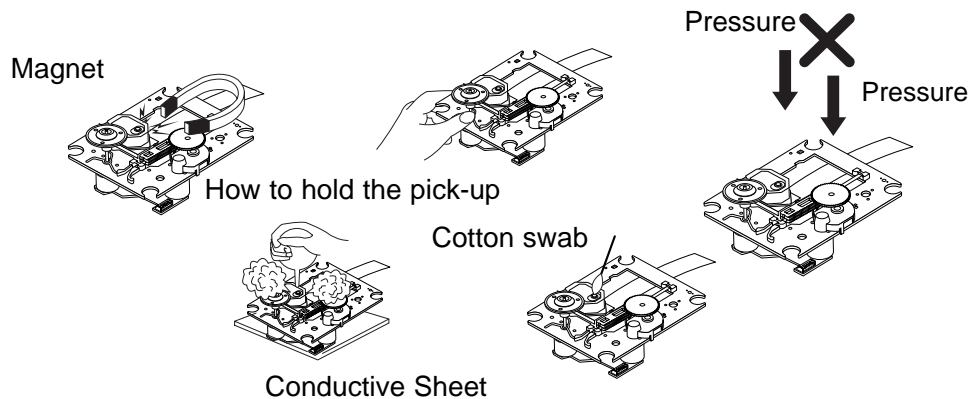

#### 6) Never attempt to disassemble the pick-up.

Spring by excess pressure. If the lens is extremely dirty, apply isopropyl alcohol to the cotton swab. (Do not use any other liquid cleaners, because they will damage the lens.) Take care not to use too much of this alcohol on the swab, and do not allow the alcohol to get inside the pick-up.

# NOTES REGARDING COMPACT DISC PLAYER REPAIRS

## 1. Preparations

- 1) Compact disc players incorporate a great many ICs as well as the pick-up (laser diode). These components are sensitive to, and easily affected by, static electricity. If such static electricity is high voltage, components can be damaged, and for that reason components should be handled with care.
- 2) The pick-up is composed of many optical components and other high-precision components. Care must be taken, therefore, to avoid repair or storage where the temperature or humidity is high, where strong magnetism is present, or where there is excessive dust.

## 2. Notes for repair

- 1) Before replacing a component part, first disconnect the power supply lead wire from the unit
- 2) All equipment, measuring instruments and tools must be grounded.
- 3) The workbench should be covered with a conductive sheet and grounded.  
When removing the laser pick-up from its conductive bag, do not place the pick-up on the bag. (This is because there is the possibility of damage by static electricity.)
- 4) To prevent AC leakage, the metal part of the soldering iron should be grounded.
- 5) Workers should be grounded by an armband (1M  $\Omega$ )
- 6) Care should be taken not to permit the laser pick-up to come in contact with clothing, in order to prevent static electricity changes in the clothing to escape from the armband.
- 7) The laser beam from the pick-up should NEVER be directly facing the eyes or bare skin.

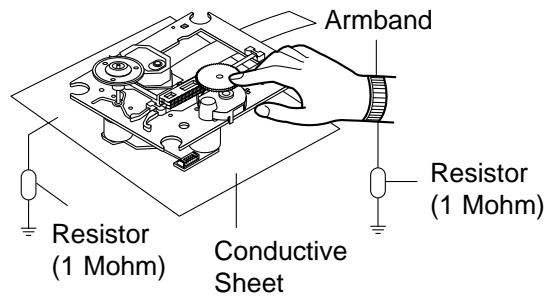

# ESD PRECAUTIONS

## Electrostatically Sensitive Devices (ESD)



Some semiconductor (solid state) devices can be damaged easily by static electricity. Such components commonly are called Electrostatically Sensitive Devices (ESD). Examples of typical ESD devices are integrated circuits and some field-effect transistors and semiconductor chip components. The following techniques should be used to help reduce the incidence of component damage caused by static electricity.

1. Immediately before handling any semiconductor component or semiconductor-equipped assembly, drain off any electrostatic charge on your body by touching a known earth ground. Alternatively, obtain and wear a commercially available discharging wrist strap device, which should be removed for potential shock reasons prior to applying power to the unit under test.
2. After removing an electrical assembly equipped with ESD devices, place the assembly on a conductive surface such as aluminum foil, to prevent electrostatic charge buildup or exposure of the assembly.
3. Use only a grounded-tip soldering iron to solder or unsolder ESD devices.
4. Use only an anti-static solder removal device. Some solder removal devices not classified as "anti-static" can generate electrical charges sufficient to damage ESD devices.
5. Do not use freon-propelled chemicals. These can generate electrical charges sufficient to damage ESD devices.
6. Do not remove a replacement ESD device from its protective package until immediately before you are ready to install it. (Most replacement ESD devices are packaged with leads electrically shorted together by conductive foam, aluminum foil or comparable conductive materials).
7. Immediately before removing the protective material from the leads of a replacement ESD device, touch the protective material to the chassis or circuit assembly into which the device will be installed.

**CAUTION : BE SURE NO POWER IS APPLIED TO THE CHASSIS OR CIRCUIT, AND OBSERVE ALL OTHER SAFETY PRECAUTIONS.**

8. Minimize bodily motions when handling unpackaged replacement ESD devices. (Otherwise harmless motion such as the brushing together of your clothes fabric or the lifting of your foot from a carpeted floor can generate static electricity sufficient to damage an ESD device).

## CAUTION. GRAPHIC SYMBOLS

	THE LIGHTNING FLASH WITH APOWHEAD SYMBOL. WITHIN AN EQUILATERAL TRIANGLE, IS INTENDED TO ALERT THE SERVICE PERSONNEL TO THE PRESENCE OF UNINSULATED "DANGEROUS VOLTAGE" THAT MAY BE OF SUFFICIENT MAGNITUDE TO CONSTITUTE A RISK OF ELECTRIC SHOCK.
	THE EXCLAMATION POINT WITHIN AN EQUILATERAL TRIANGLE IS INTENDED TO ALERT THE SERVICE PERSONNEL TO THE PRESENCE OF IMPORTANT SAFETY INFORMATION IN SERVICE LITERATURE.

# SPECIFICATIONS

## GENERAL

Power supply	Refer to main label
Power consumption	Refer to main label
Weight	2.5 kg
External dimensions (W x H x D)	360 x 56 x 310 mm
Operating conditions Temperature:	5°C to 35°C, Operation status: Horizontal
Operating humidity	5% to 85%

## CD/DVD

Laser	Semiconductor laser, wavelength 650 nm
Signal system	PAL 625/50, NTSC 525/60
Frequency response (audio)	140 Hz to 20 kHz
Signal-to-noise ratio (audio)	More than 75 dB (1 kHz, NOP-3dB, 20 kHz LPF/A-Filter)
Dynamic range (audio)	More than 80 dB
Harmonic distortion (audio)	0.5 % (1 kHz, at 12W position) (20 kHz LPF/A-Filter)
Video output	1.0 V (p-p), 75 Ω, negative sync., RCA jack

## TUNER

### FM

Tuning Range	87.5 - 108.0 MHz or 65.0 - 74.0 MHz, 87.5 - 108.0 MHz
Intermediate Frequency	10.7 MHz
Signal-to Noise Ratio	60 dB (Mono)
Frequency Response	140 - 10,000 Hz

### AM [MW]

Tuning Range	522 - 1,620 kHz or 520 - 1,720 kHz
Intermediate	Frequency 450 kHz

## AMPLIFIER

Surround mode	Front: 30W + 30W (THD 10 %)
(* Depending on the sound mode settings and the source, there may be no sound output.)	Center*: 30W
	Surround*: 30W + 30W (6Ω at 1 kHz, THD 10 %)
	Subwoofer*: 70W (8Ω at 30 Hz, THD 10 %)
Outputs	MONITOR
	MIC Jacks (ø3.5mm) (KARAOKE MODEL ONLY))

## SPEAKERS

	Satellite Speaker (LHS-25SCS)	Passive Subwoofer (LHS-25SCW)
Type	1 Way 1 Speaker	1 Way 1 Speaker
Impedance	6 Ω	8 Ω
Frequency Response	160 - 20,000 Hz	65 - 1,500 Hz
Sound Pressure Level	84 dB/W (1m)	82 dB/W (1m)
Rated Input Power	30W	70W
Max. Input Power	60W	140W
Net Dimensions (W x H x D)	92 x 115 x 80 mm	160 x 350 x 280 mm
Net Weight	0.5 kg	3.18 kg

# MEMO

A series of horizontal dotted lines for writing.

# SECTION 2. AUDIO PART

## AUDIO TROUBLESHOOTING GUIDE

### 1. POWER SUPPLY CIRCUIT

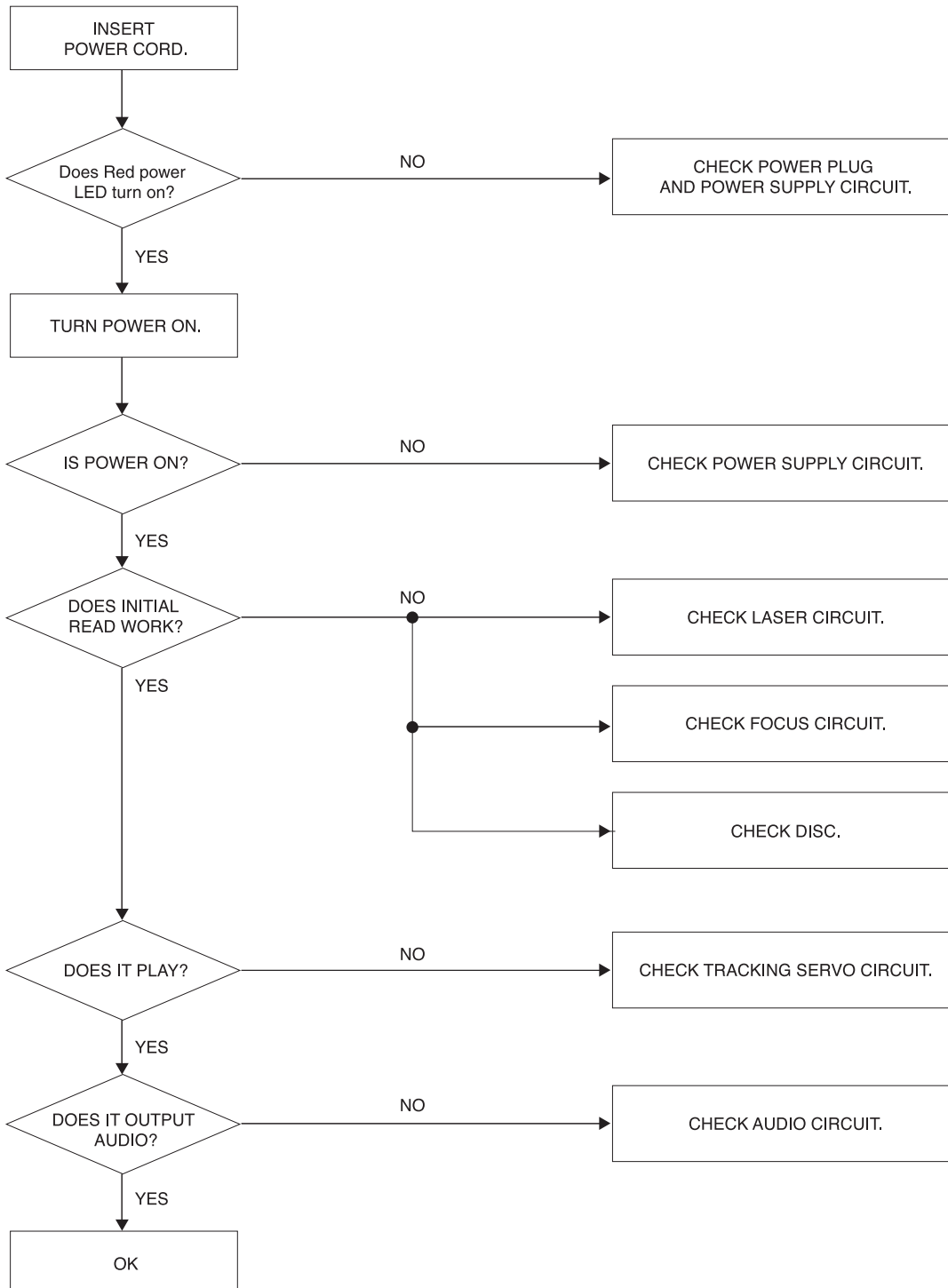

## 2. FRONT CIRCUIT (1/2)

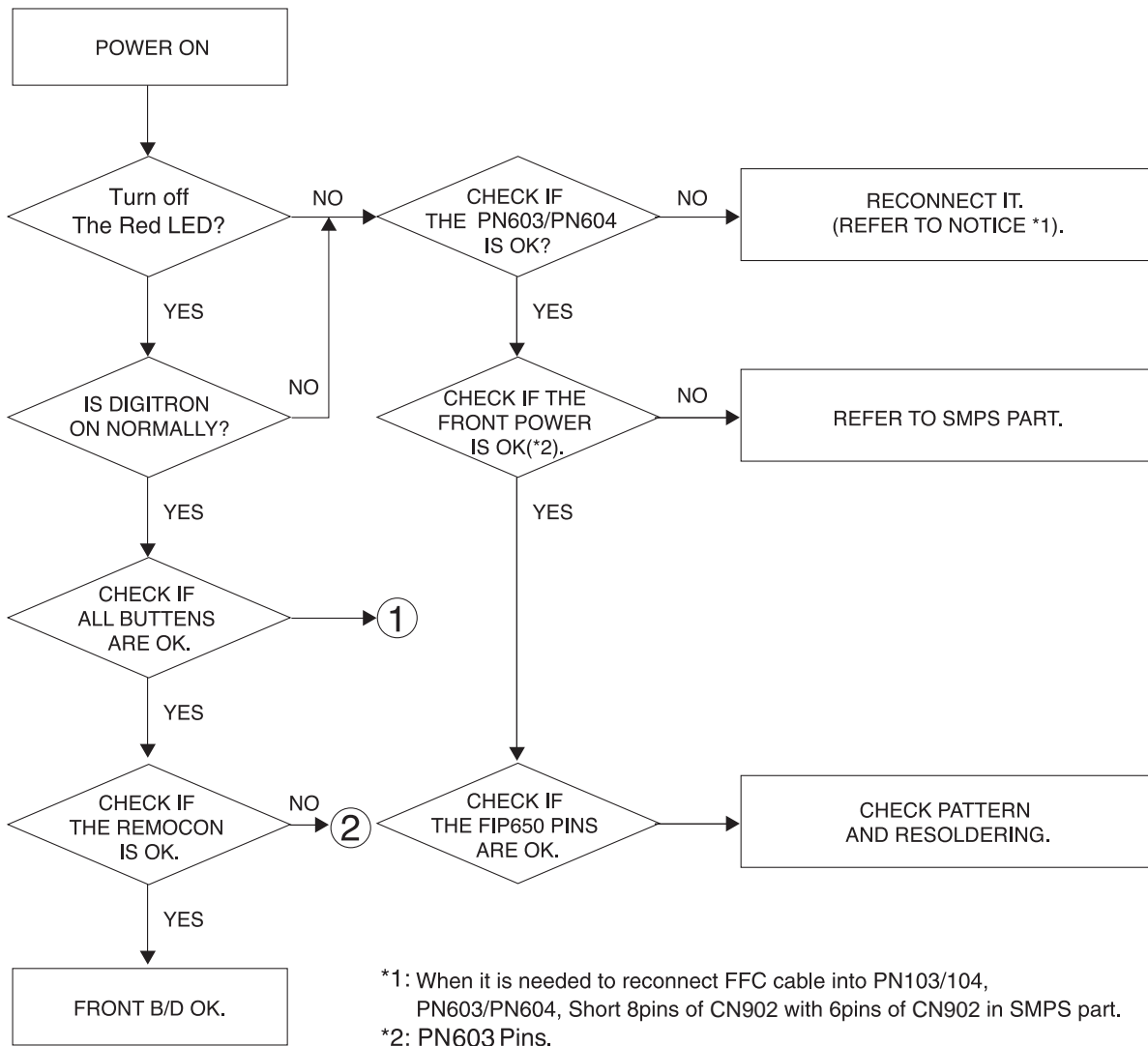

\*1: When it is needed to reconnect FFC cable into PN103/104, PN603/PN604, Short 8pins of CN902 with 6pins of CN902 in SMPS part.

\*2: PN603 Pins.

PIN1 : -32.4 VKK

PIN3 : -27.5 FL-

PIN4 : -23.7 FL+

PIN9 : +5.0



### 3. FRONT CIRCUIT (2/2)

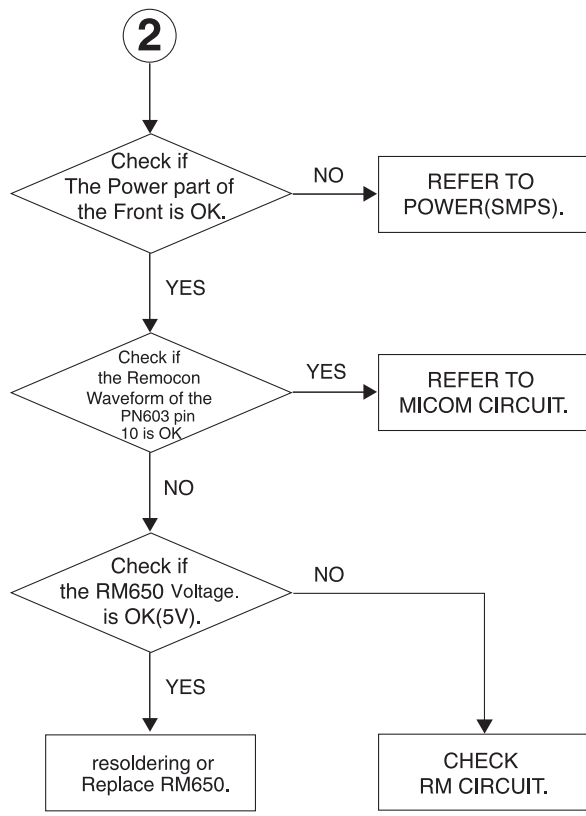
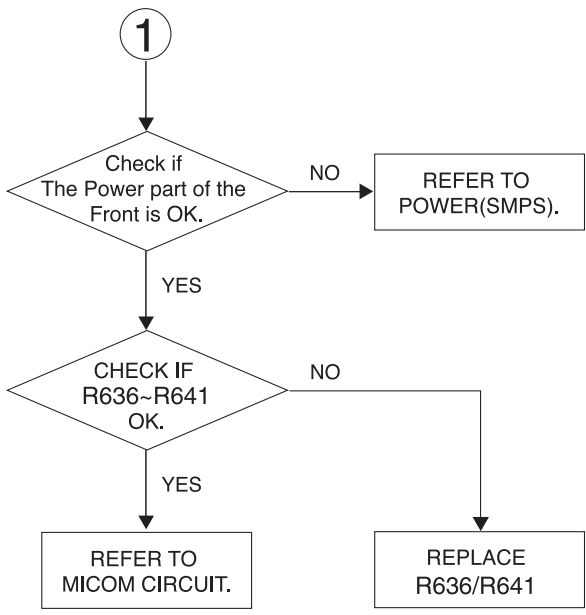

# MEMO

A series of horizontal dotted lines for writing.

# BLOCK DIAGRAM

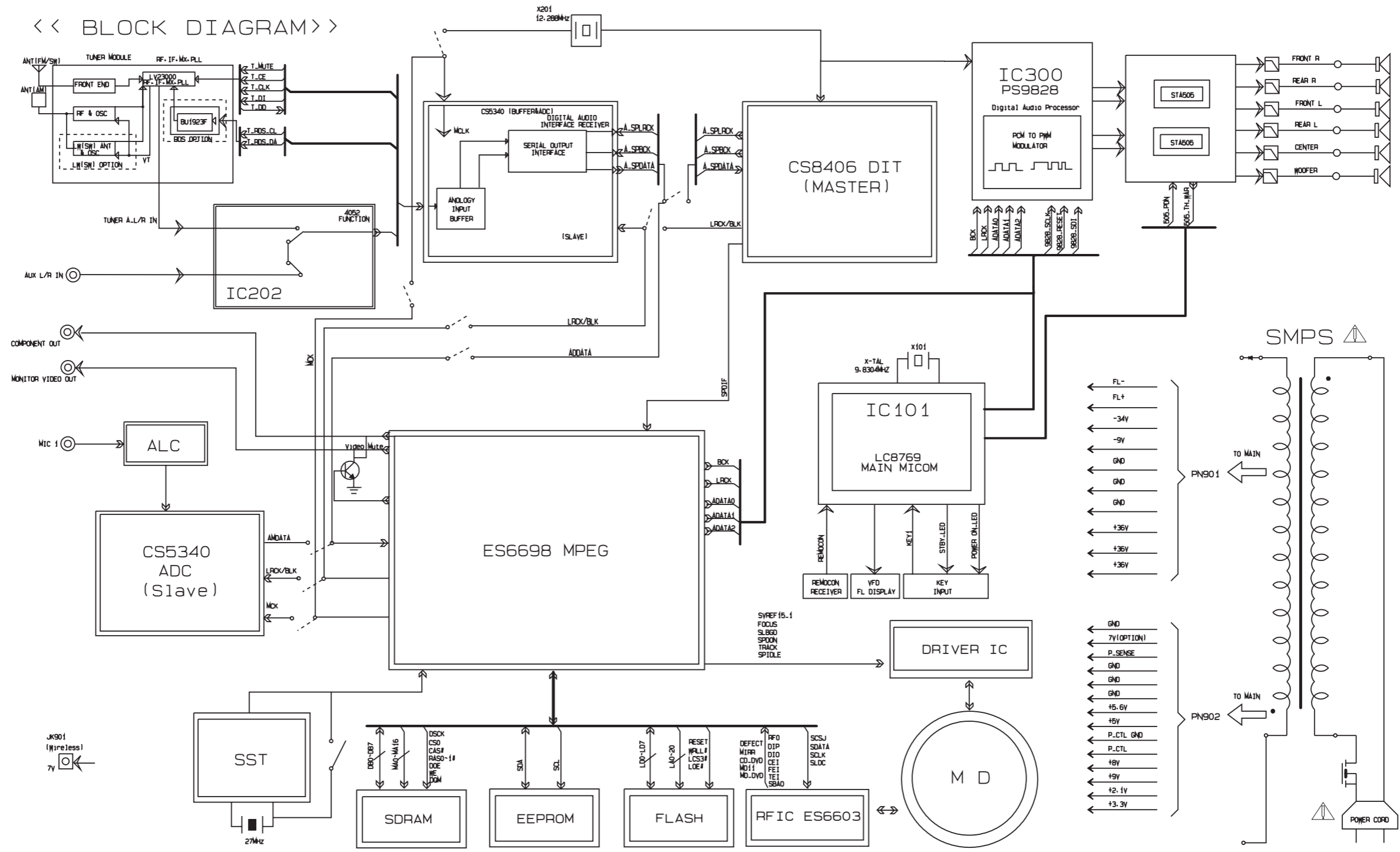

SCHEMATIC DIAGRAM (BLOCK DIAGRAM)  
LH-TK250

# SCHEMATIC DIAGRAMS

## 1. POWER SCHEMATIC DIAGRAM

NOTES) ⚠ Warning  
Parts that are shaded are critical  
With respect to risk of fire or  
electrical shock.

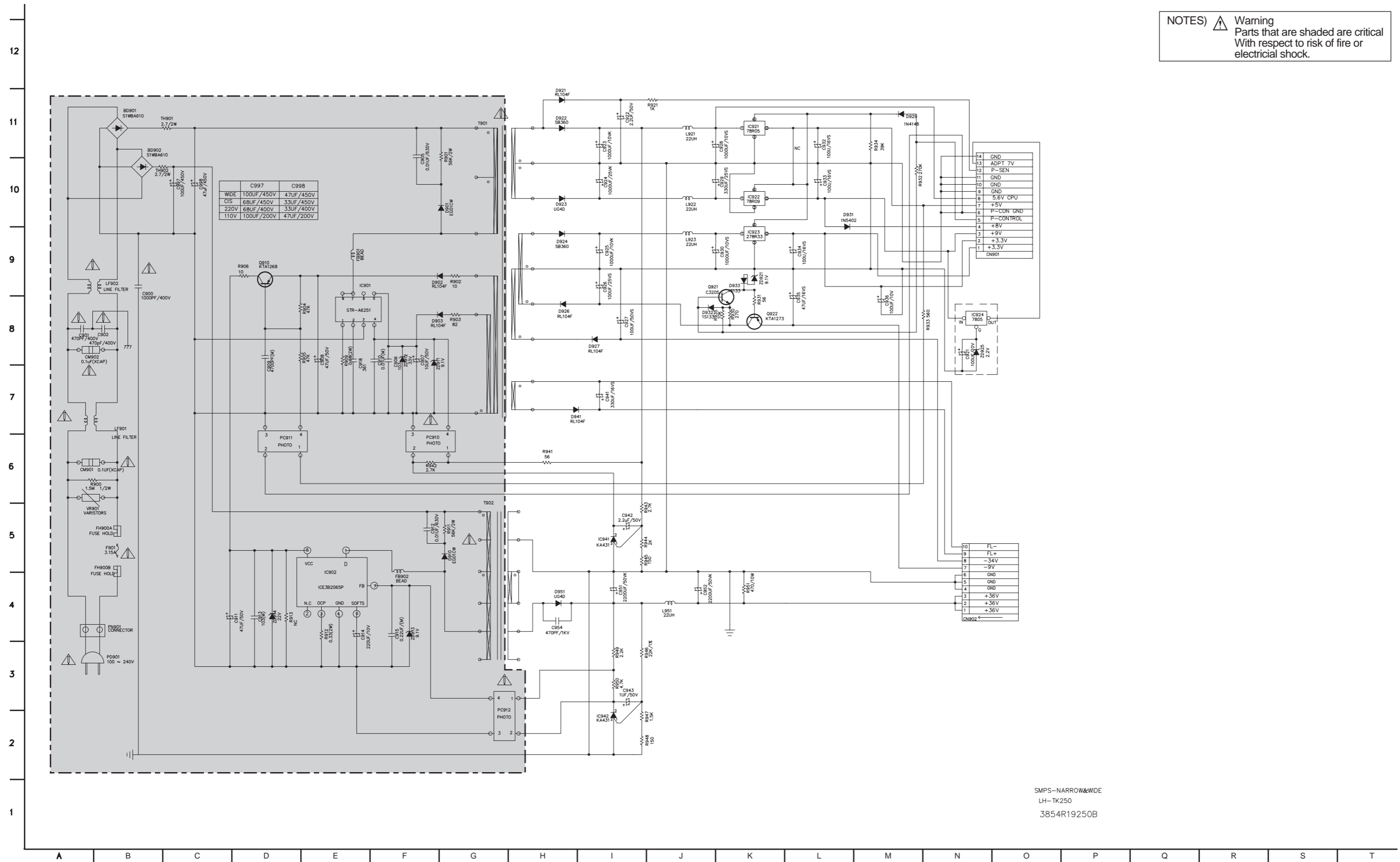

SMPS-NARROW&WIDE  
LH-TK250  
3854R19250B



### 3. MICOM SCHEMATIC DIAGRAM

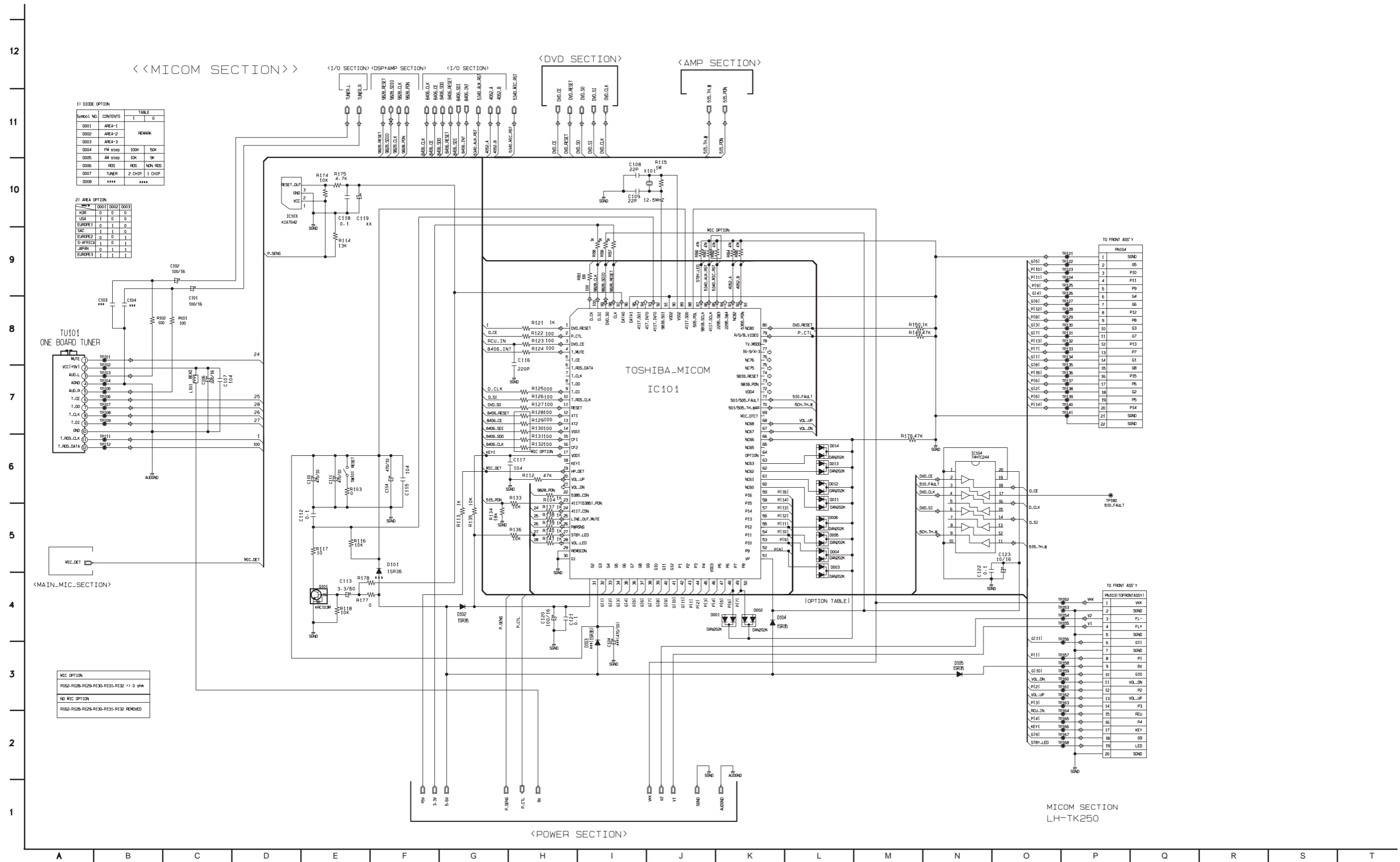

# 4. FRONT SCHEMATIC DIAGRAM

<<FRONT SECTION>>

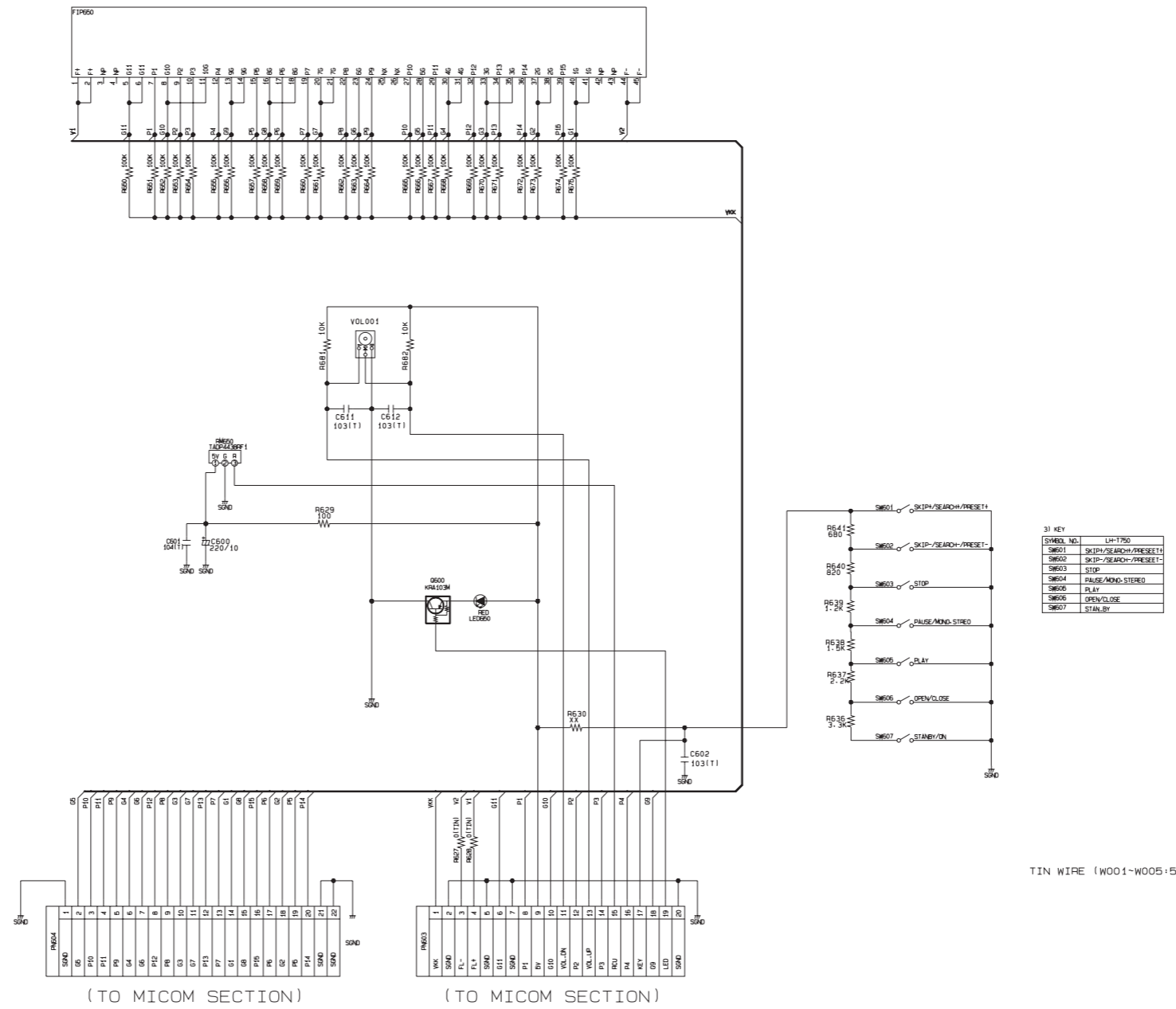

TIN WIRE (W001-W005:5EA)

FRONT (SCHEMATIC)  
LH-TK250

# 5. DSP&AMP SCHEMATIC DIAGRAM

<< DSP+AMP SECTION >>

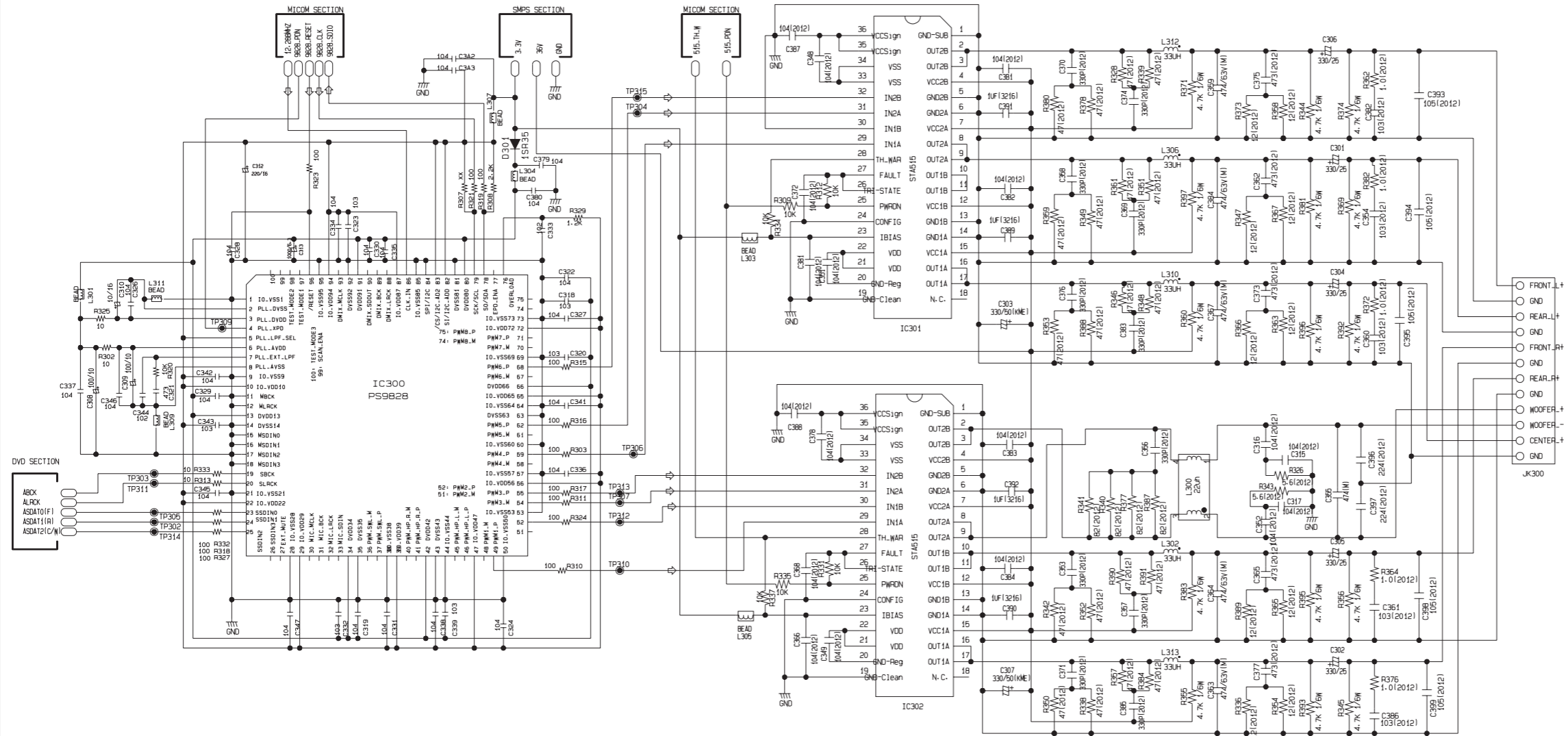

SCHEMATIC DIAGRAM [DSP+AMP]  
LH-TK250



# 6. I/O SCHEMATIC DIAGRAM

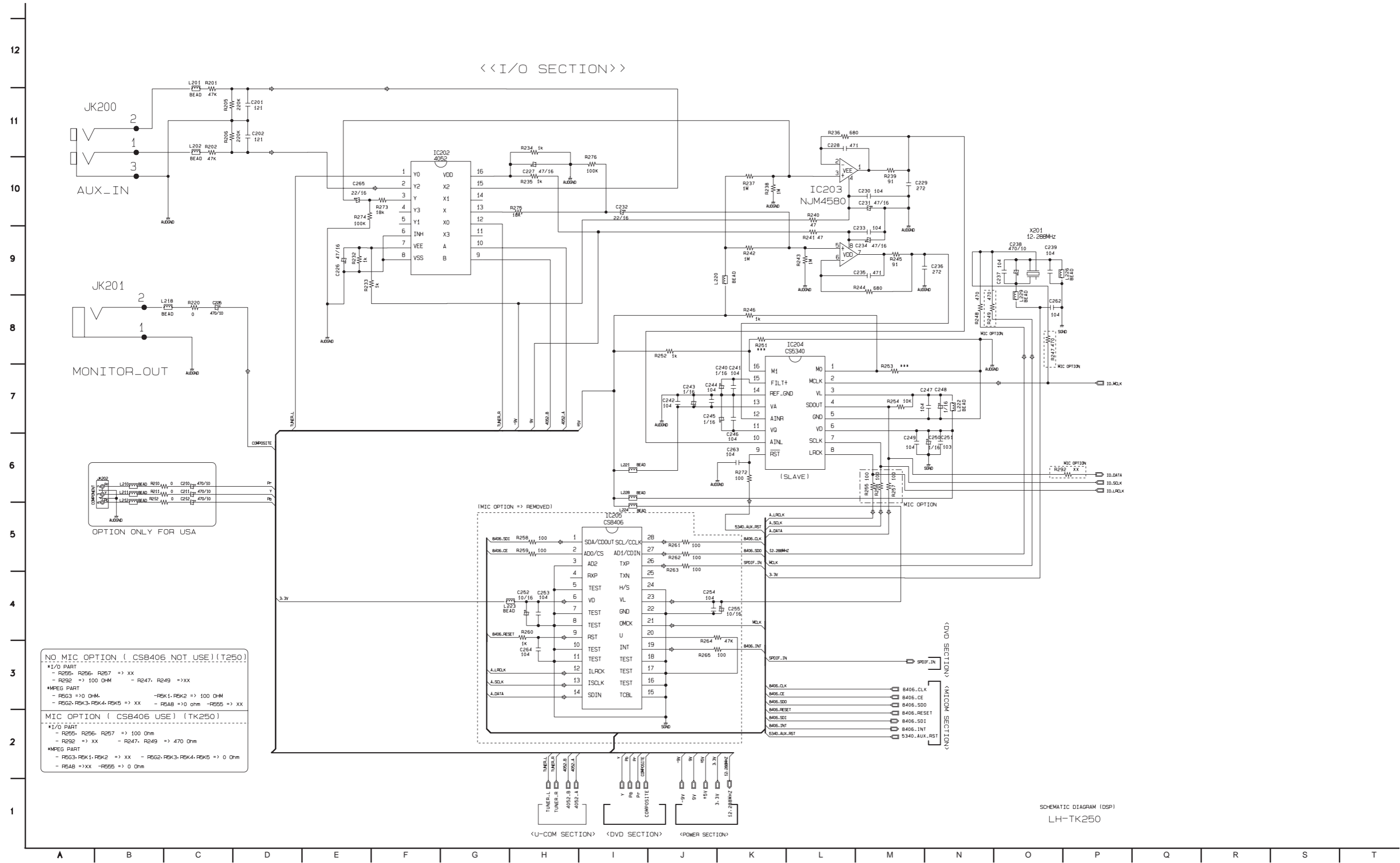

# 7. MAIN MIC SCHEMATIC DIAGRAM

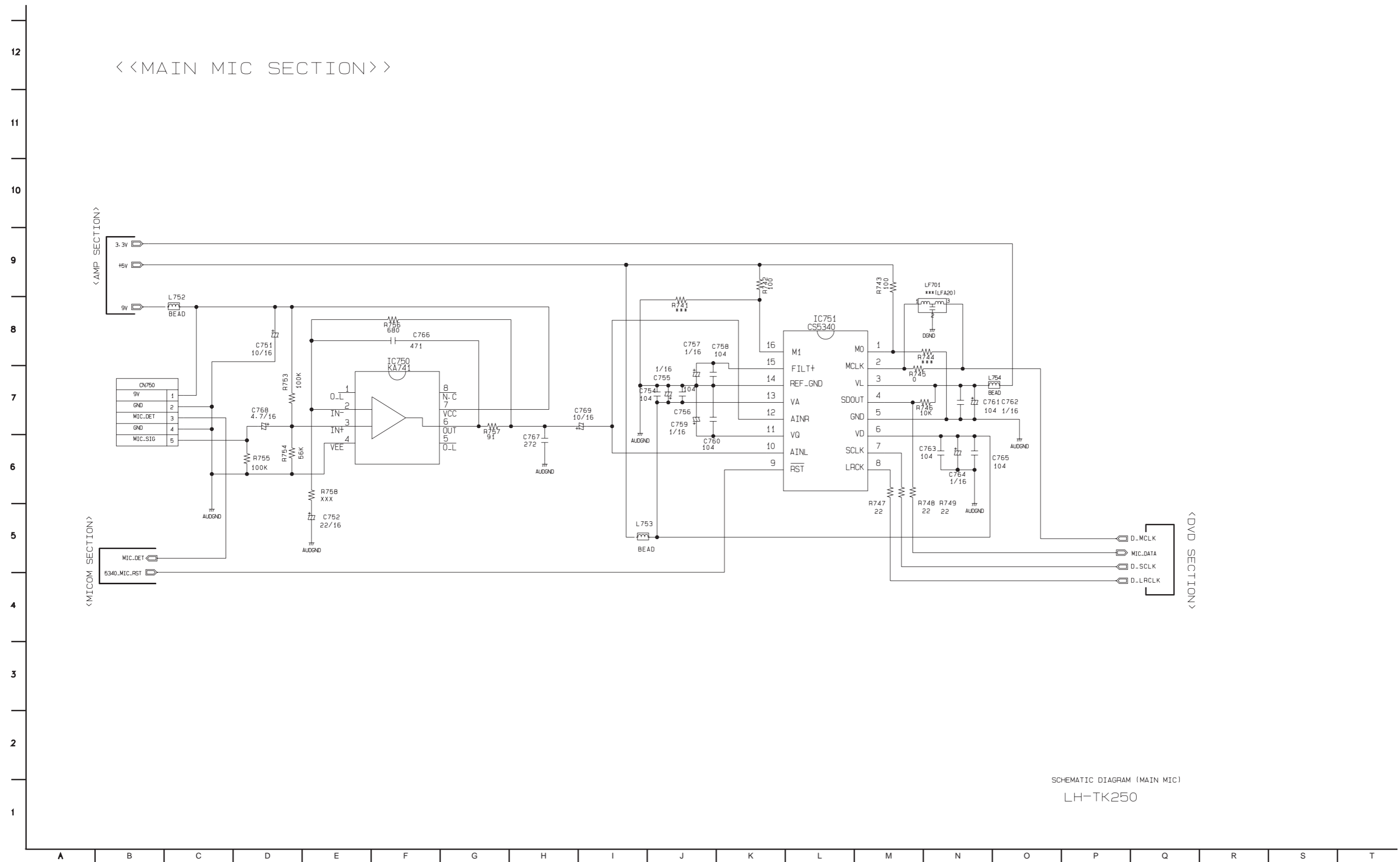

SCHEMATIC DIAGRAM (MAIN MIC)  
LH-TK250

# WIRING DIAGRAM

<<WIRING DAIGRAM>>

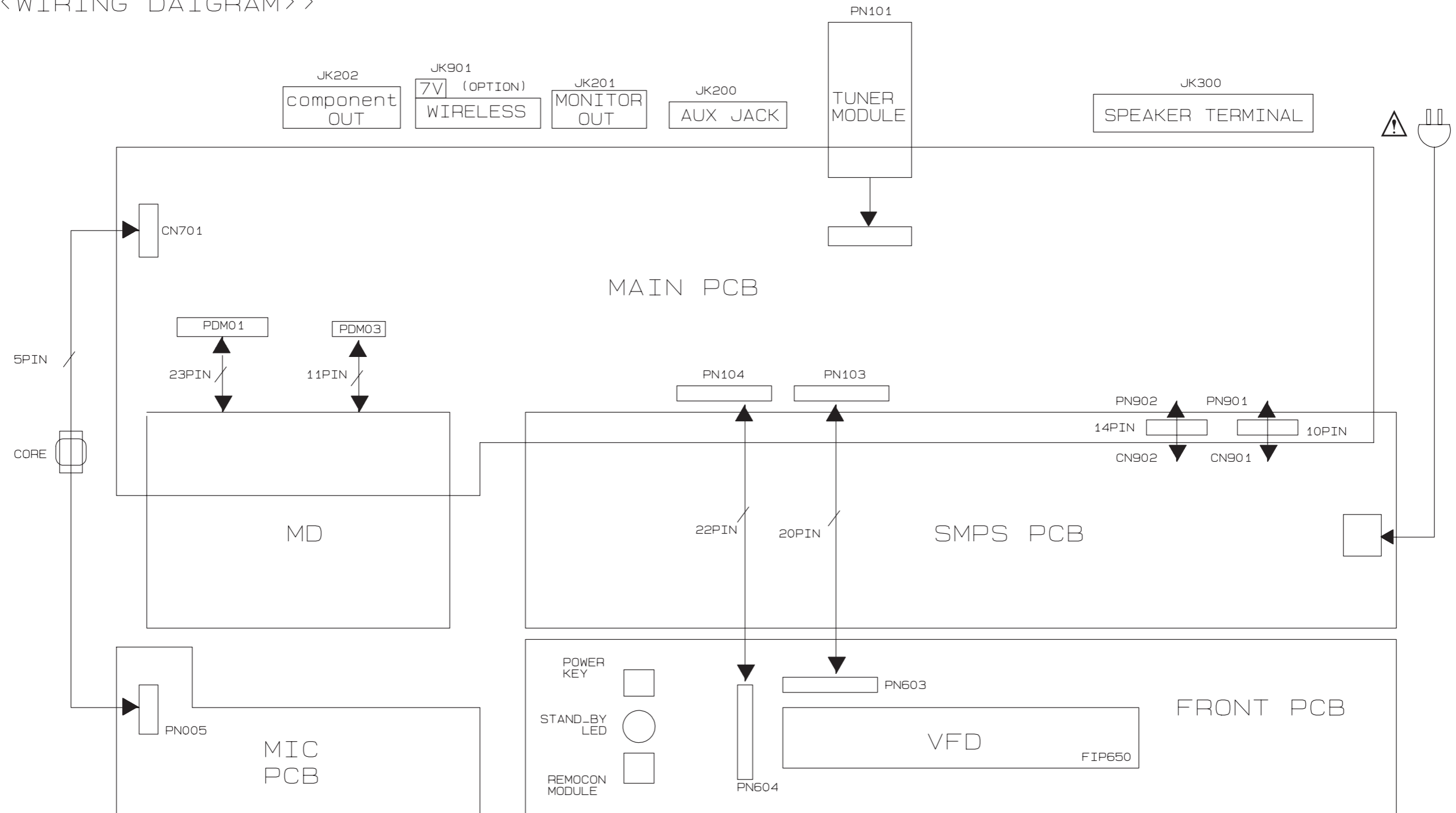

NOTES) ⚠ Warning  
Parts that are shaded are critical  
With respect to risk of fire or  
electrical shock.

SCHEMATIC DIAGRAM (WIRING DIAGRAM)  
LH-TK250



## 2. MAIN/DVD P.C. BOARD DIAGRAM (BOTTOM)

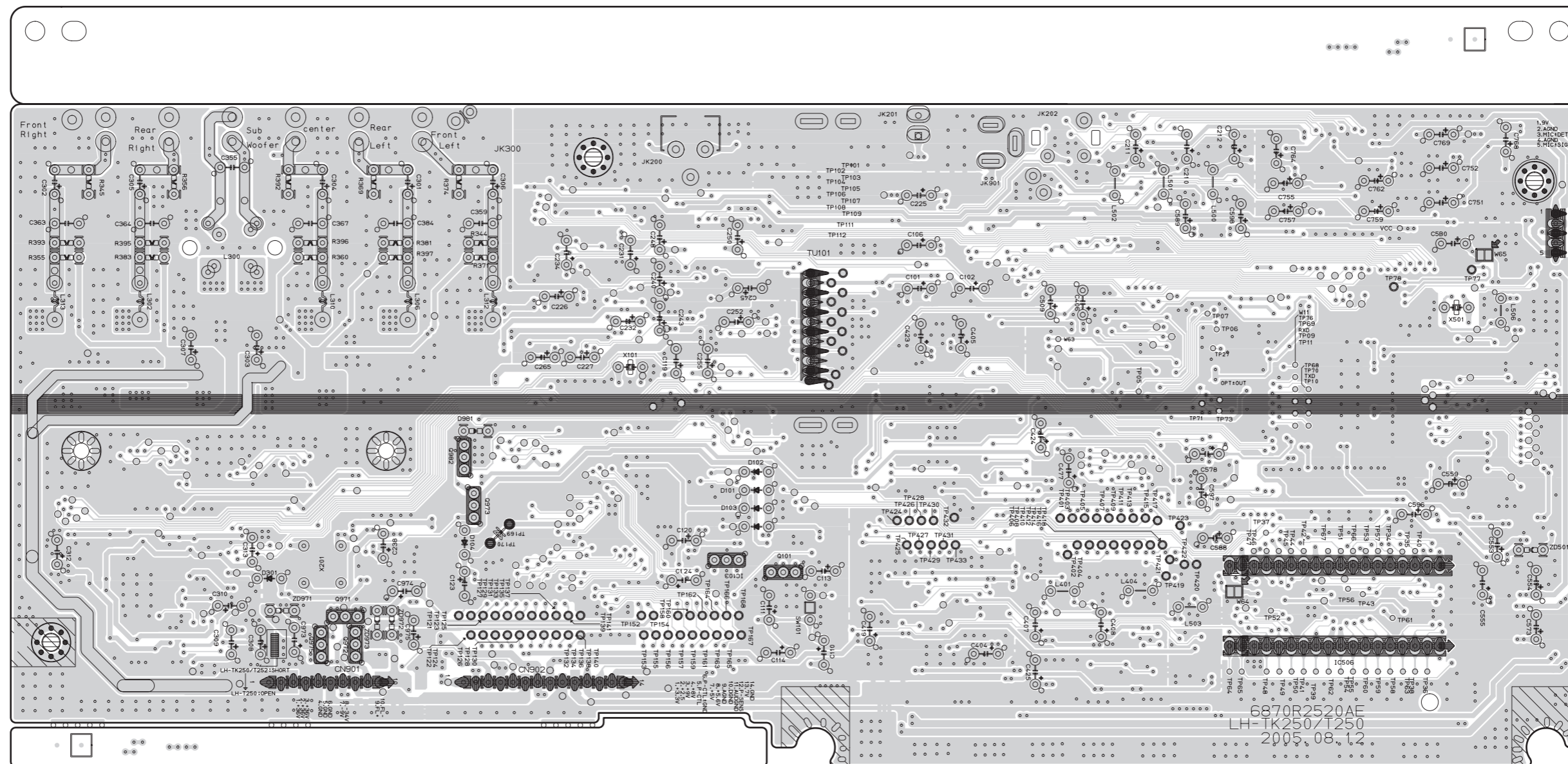

### 3. FRONT P.C. BOARD

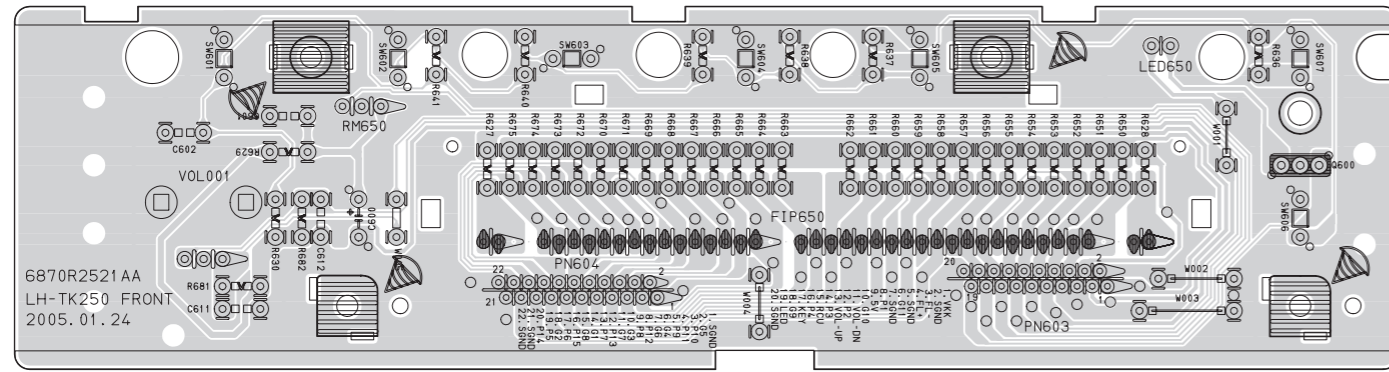

## 4. SMPS P.C. BOARD

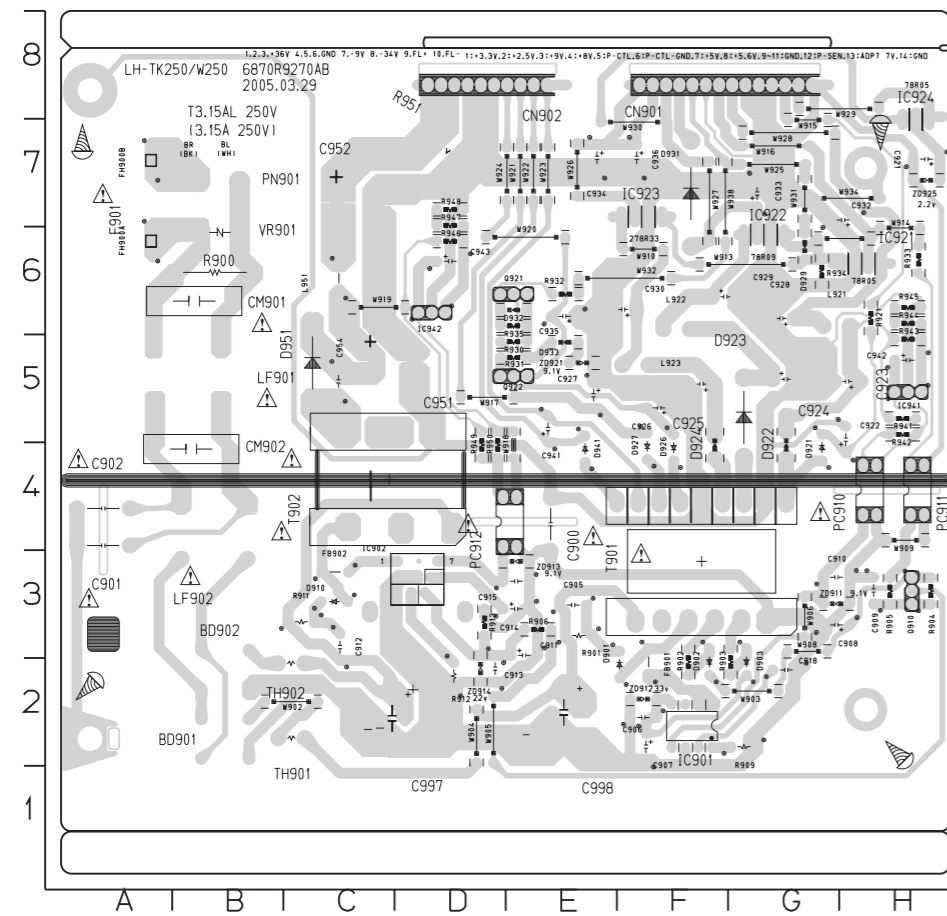

### LOCATION GUIDE

BD901	B2	CN901	F8	Q922	E5
BD902	B2	CN902	E8	R900	B6
C900	E4	D901	F2	R901	E3
C901	A4	D902	F2	R902	F2
C902	A4	D903	G2	R903	G2
C905	E3	D910	C3	R904	H3
C906	F2	D921	G4	R905	H3
C907	F2	D922	G4	R906	E3
C908	G3	D923	G5	R909	G2
C909	H3	D924	F4	R911	C3
C910	G3	D926	F4	R912	D2
C911	E3	D927	F4	R913	D3
C912	C3	D929	G6	R921	H6
C913	D2	D931	F7	R930	E5
C914	E3	D932	E6	R931	E5
C915	E3	D933	E5	R932	E6
C918	C2	D941	E4	R933	H6
C921	H7	D951	C5	R934	G6
C922	H5	FB901	F2	R935	E6
C923	H5	FB902	C3	R941	H5
C924	G5	FH900A	A6	R942	H5
C925	F5	FH900B	A7	R943	H5
C926	F5	IC901	F2	R944	H6
C927	E5	IC902	D3	R945	H6
C928	G6	IC921	H6	R946	D6
C929	F6	IC922	G6	R947	D7
C930	F6	IC923	F7	R948	D7
C932	H7	IC924	H7	R949	D4
C933	G7	IC941	H5	R950	D4
C934	E7	IC942	D6	R951	D7
C935	E6	L921	G6	T901	F3
C936	F7	L922	F6	T902	C4
C941	E5	L923	F5	TH901	C2
C942	H5	L951	C6	TH902	C2
C943	D6	LF901	B5	VR901	B6
C951	D5	LF902	B4	ZD911	G3
C952	C7	PC910	H4	ZD912	F2
C954	C5	PC911	H4	ZD913	E3
C997	C2	PC912	D4	ZD914	D2
C998	E2	PN901	B7	ZD921	E5
CM901	B6	Q910	H3	ZD925	H7
CM902	B4	Q921	E6		

NOTES) ⚠ Warning  
Parts that are shaded are critical  
With respect to risk of fire or  
electrical shock.

## 5. JACK P.C. BOARD

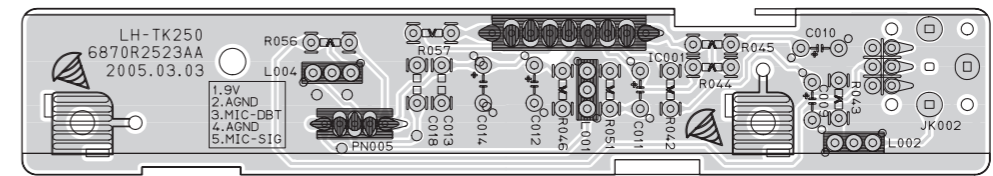





# SECTION 3. DVD & AMP PART

## ELECTRICAL TROUBLESHOOTING GUIDE

### 1. System operation flow

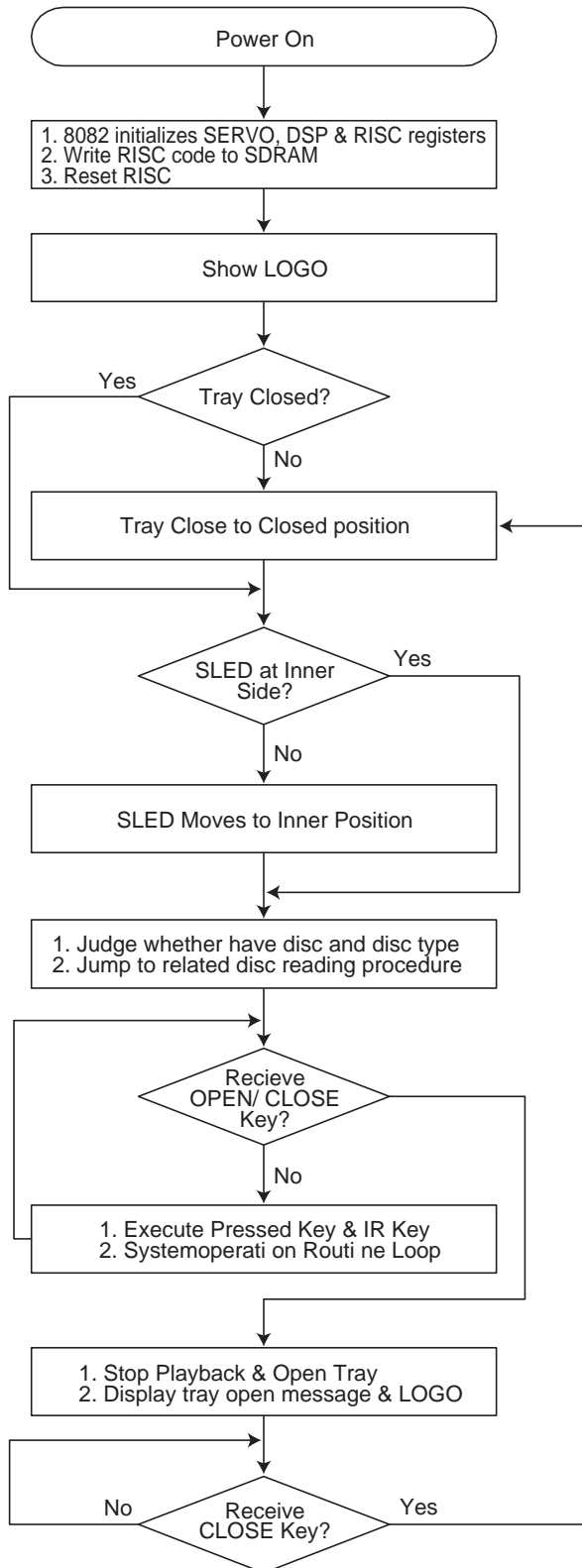

## 2. Test & debug flow

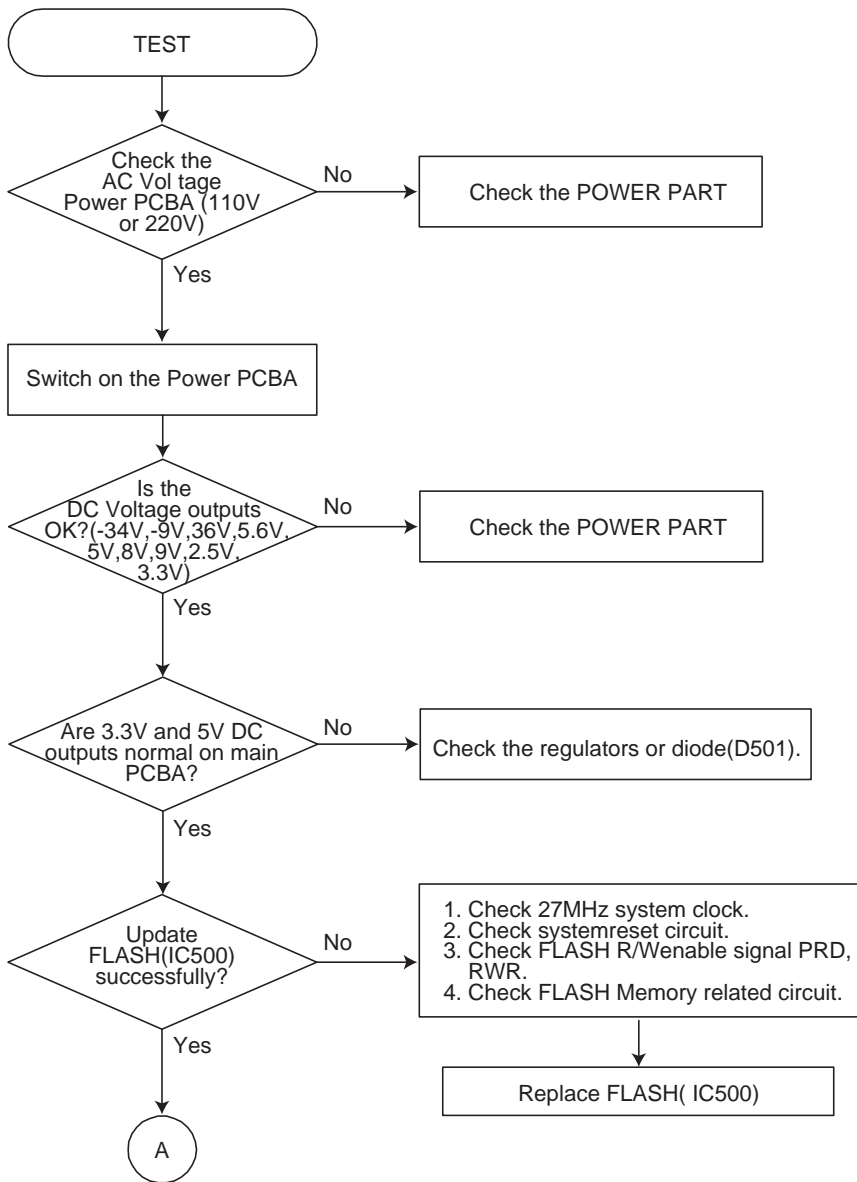

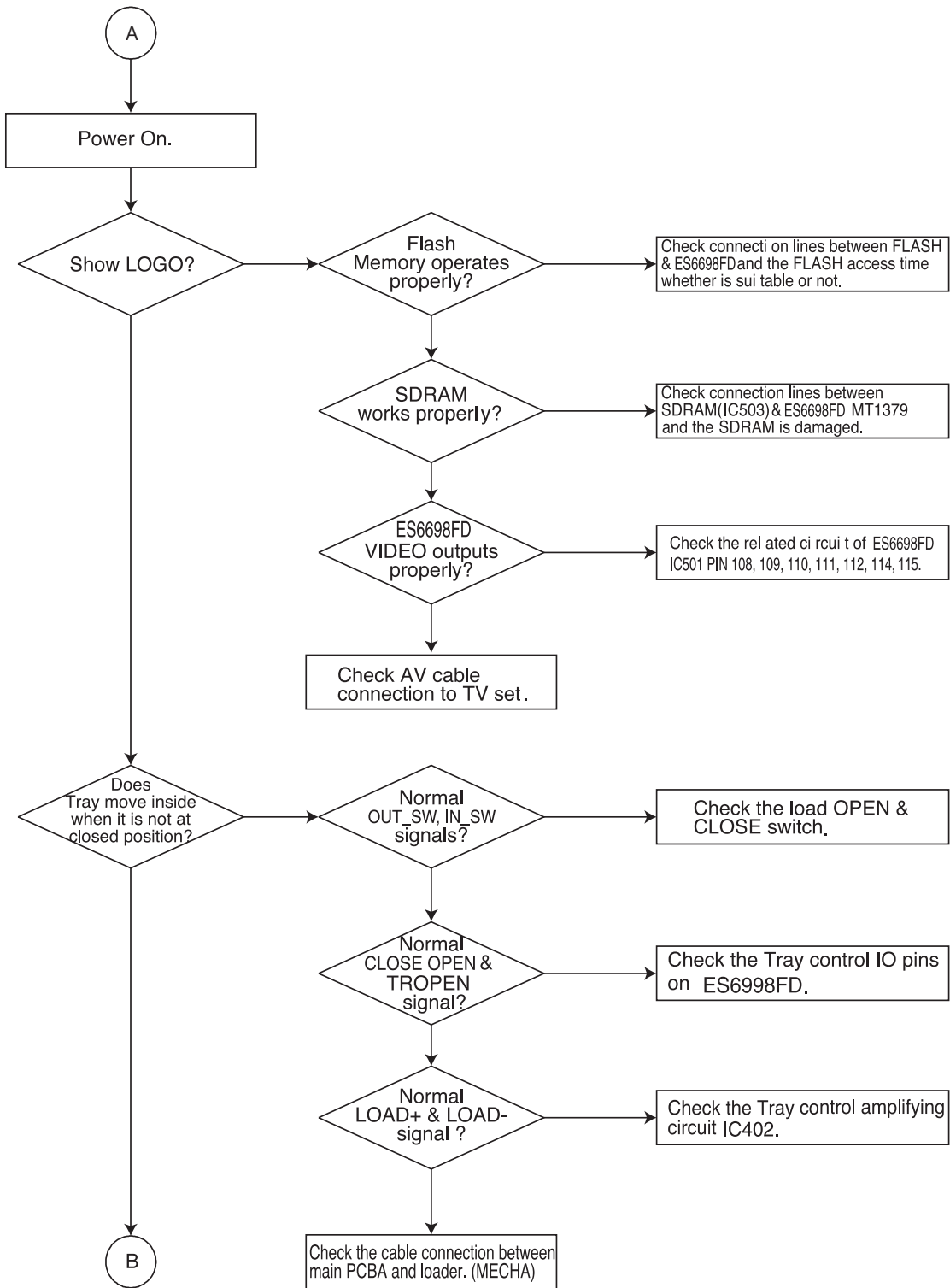

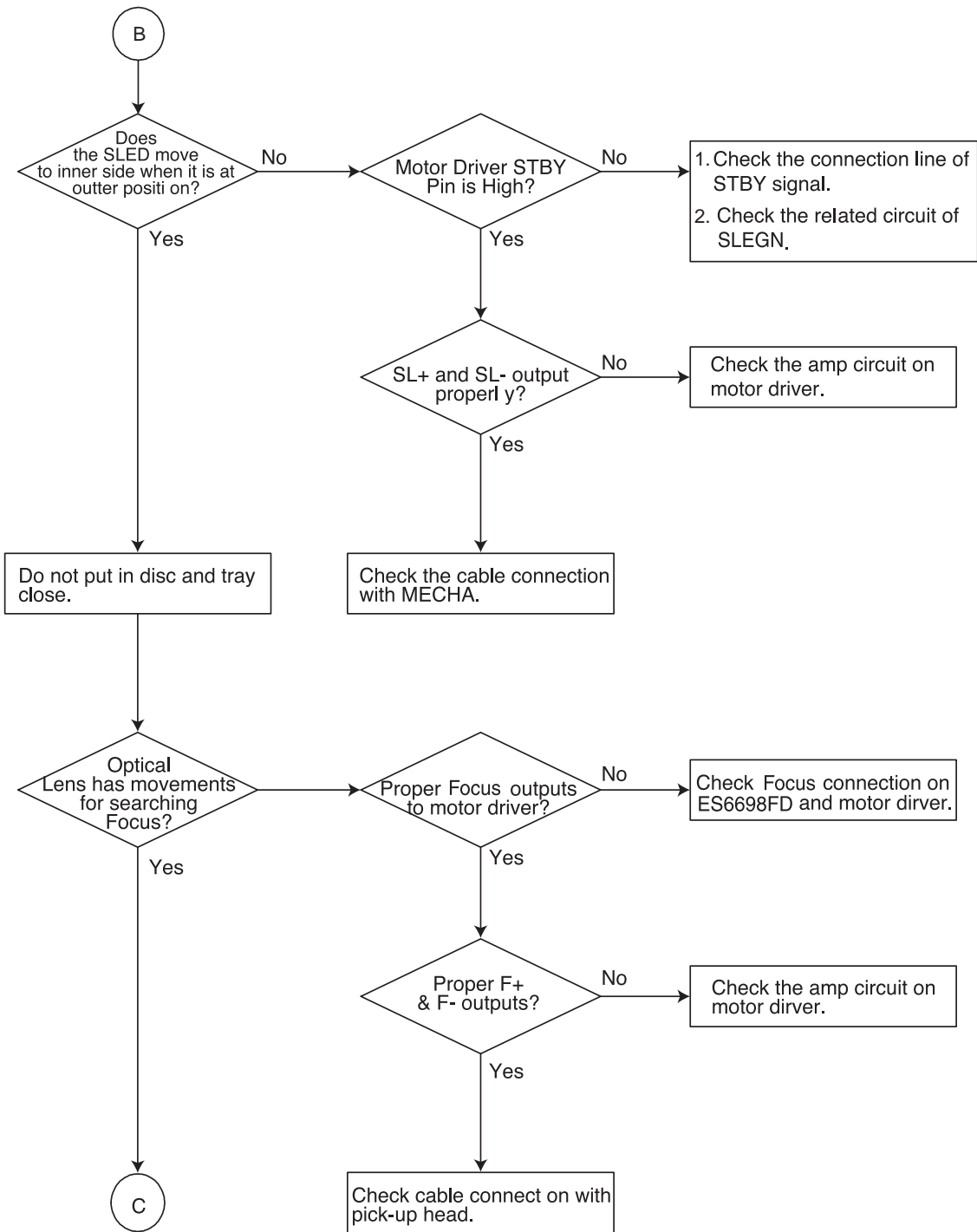

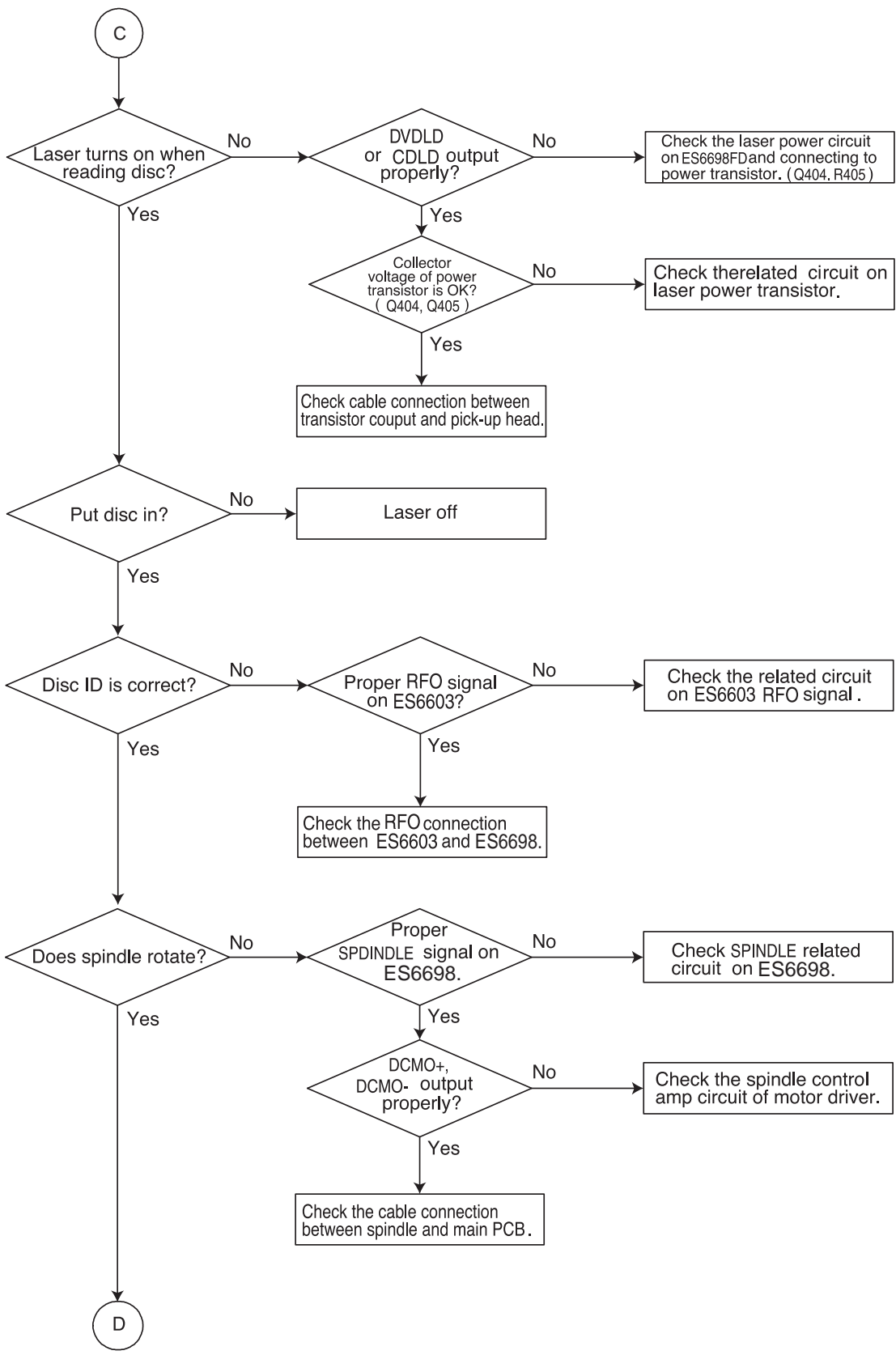

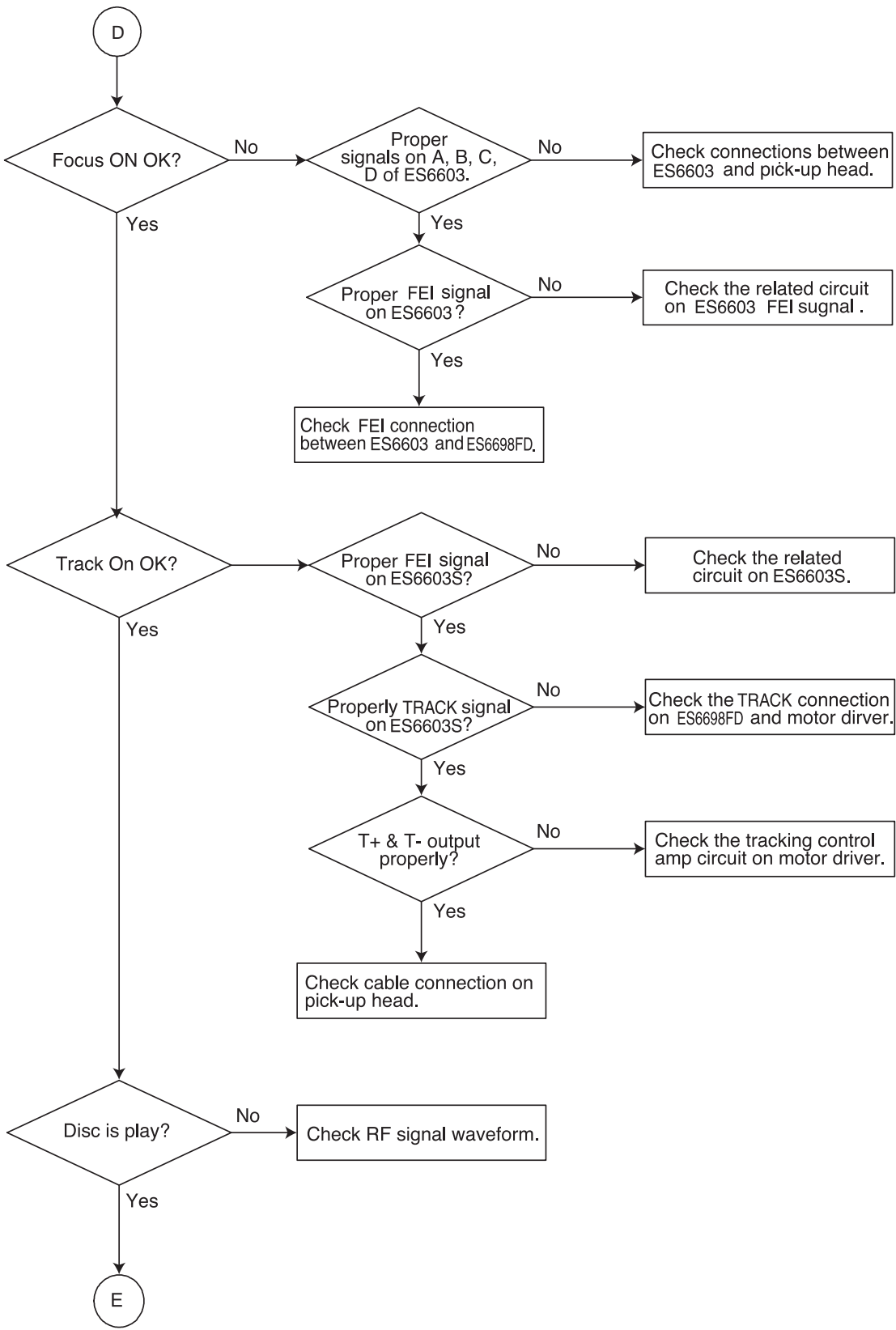

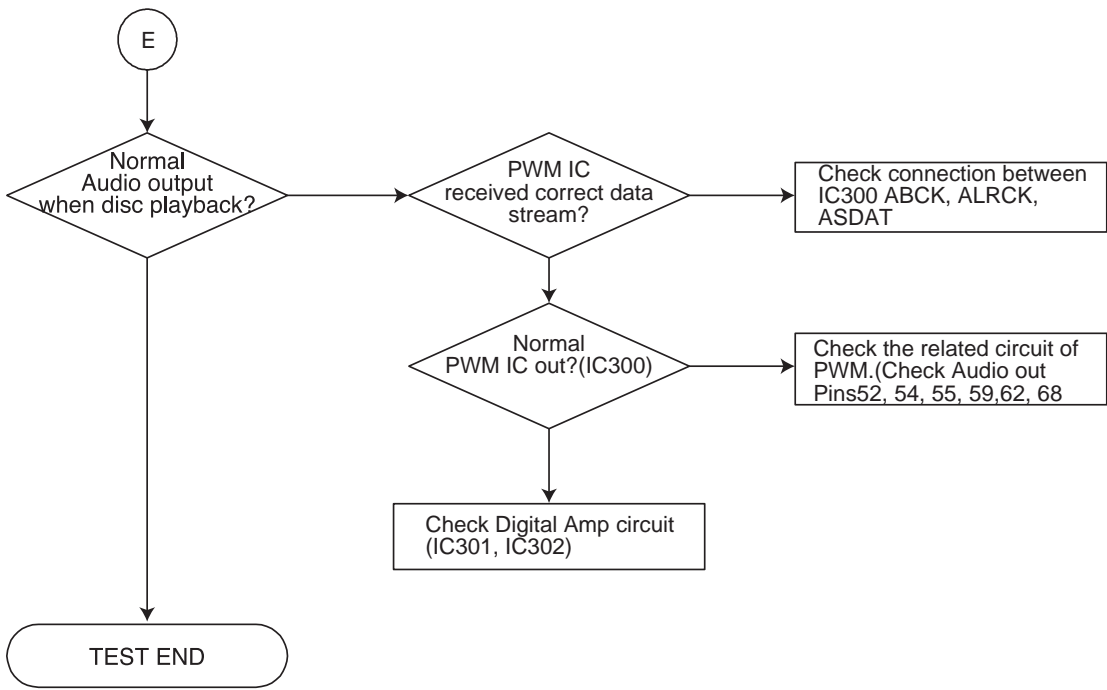

### 3. AUDIO $\mu$ -COM Circuit(DVD & AMP)

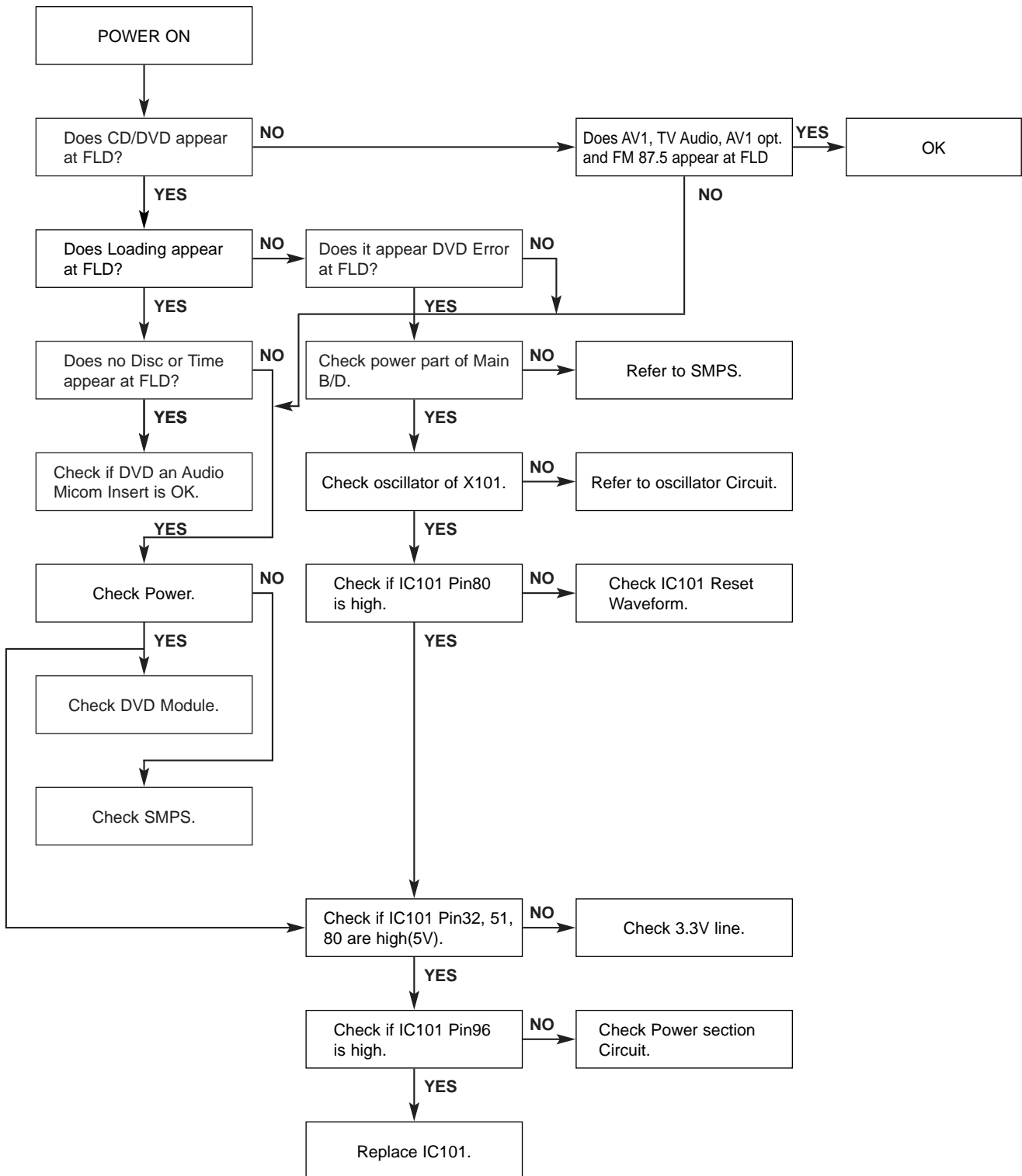



# DETAILS AND WAVEFORMS ON SYSTEM TEST AND DEBUGGING

## 1. SYSTEM 27MHz CLOCK,RESET,FLASH R/W SIGNAL

### 1) ES6698FD main clock is at 27MHz(X501)

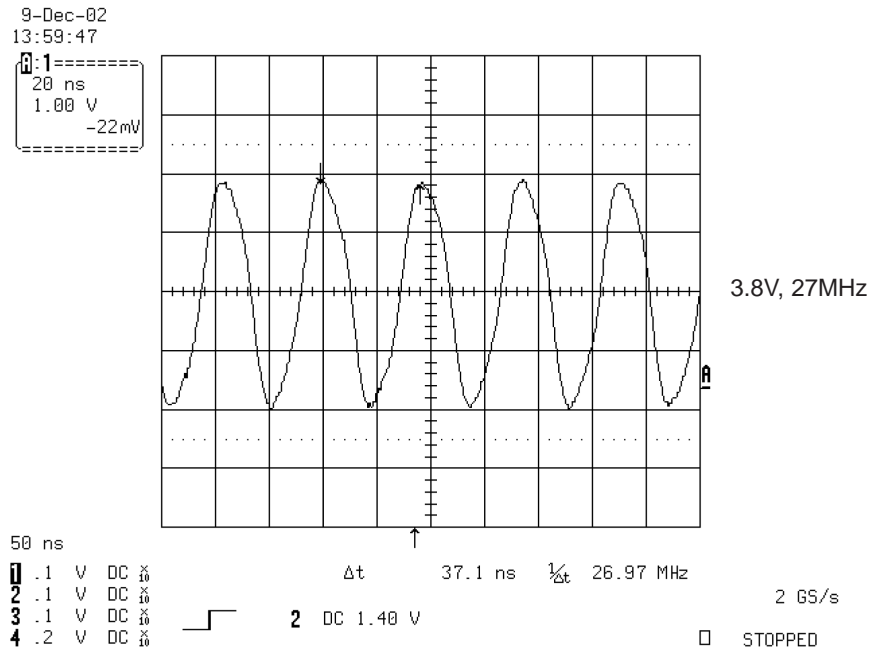

FIG 1-1

### 2) ES6698FD reset is high active.

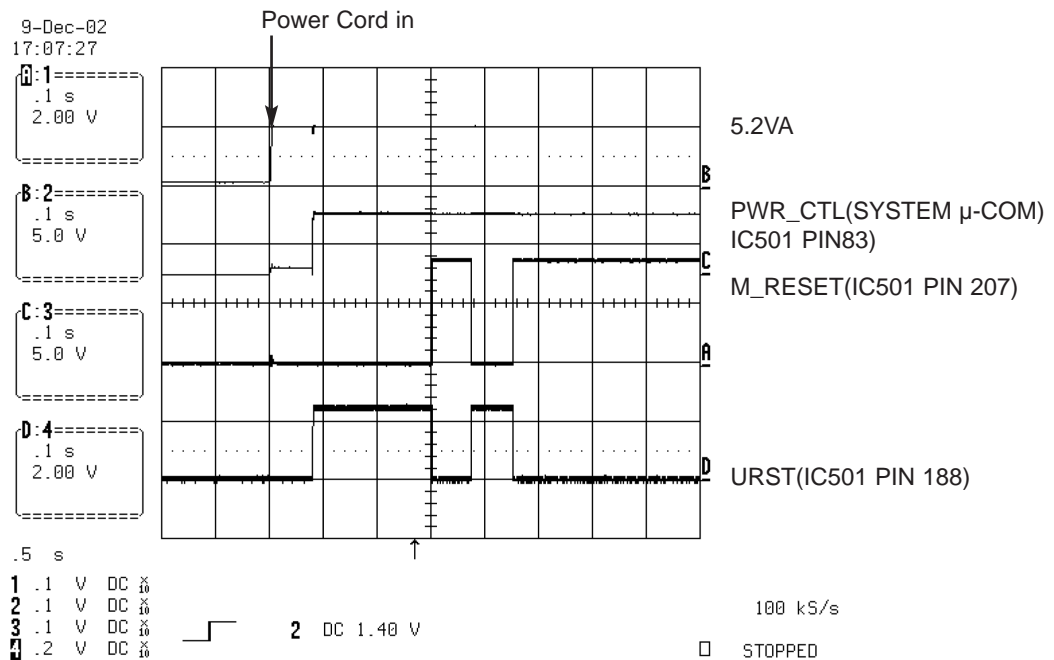

FIG 1-2

#### 4) Flash R/W enable signal during download(Downloading)

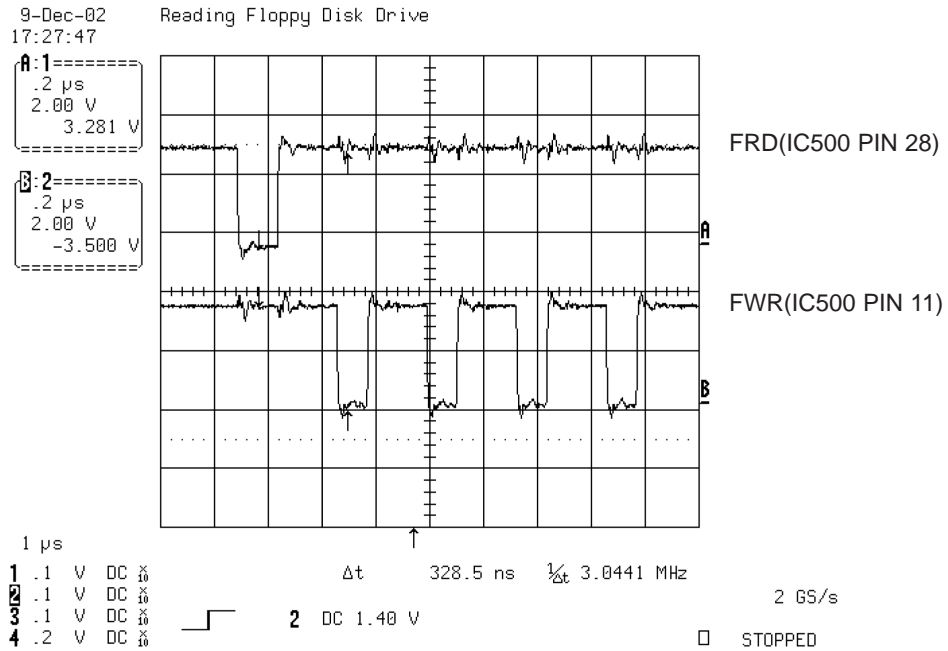

FIG 1-4

## 2. SDRAM CLOCK

### 1) ES6698FD main clock is at 27MHz(X501)

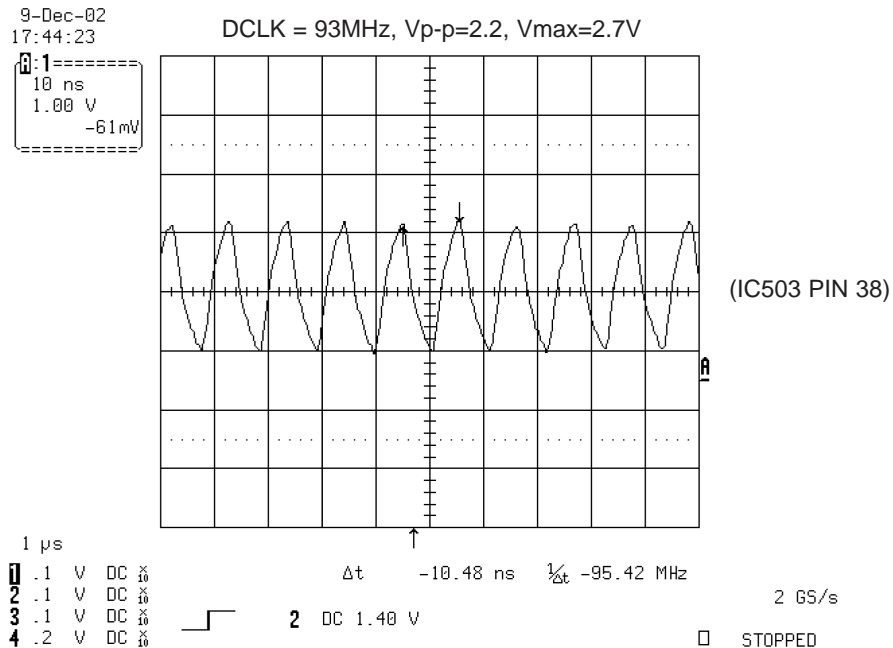

FIG 2-1

### 3. TRAY OPEN/CLOSE SIGNAL

#### 1) Tray open/close waveform

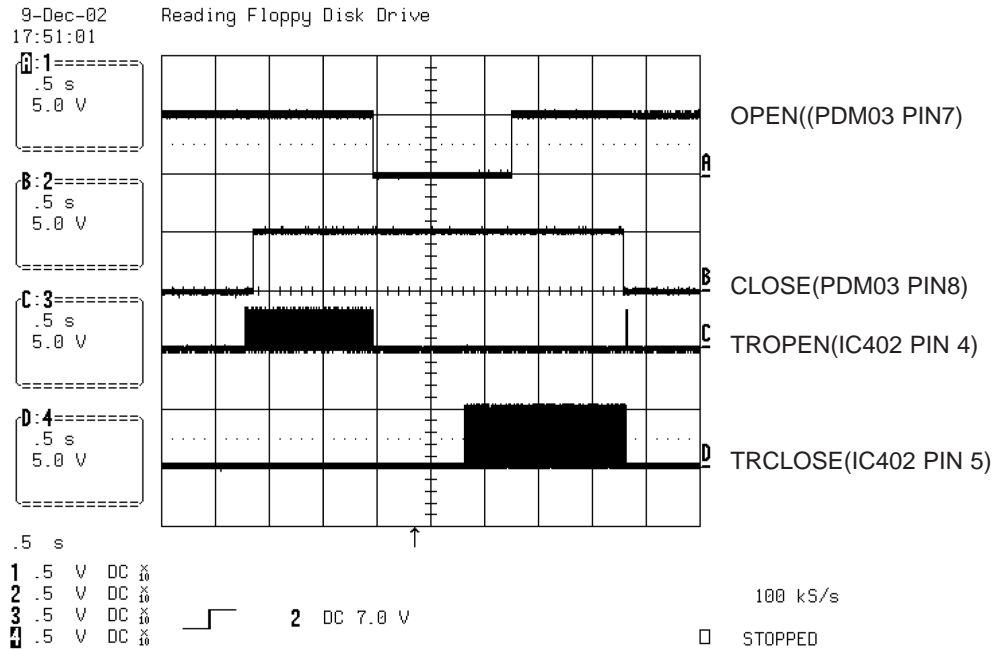

FIG 3-1

#### 2) Tray close waveform

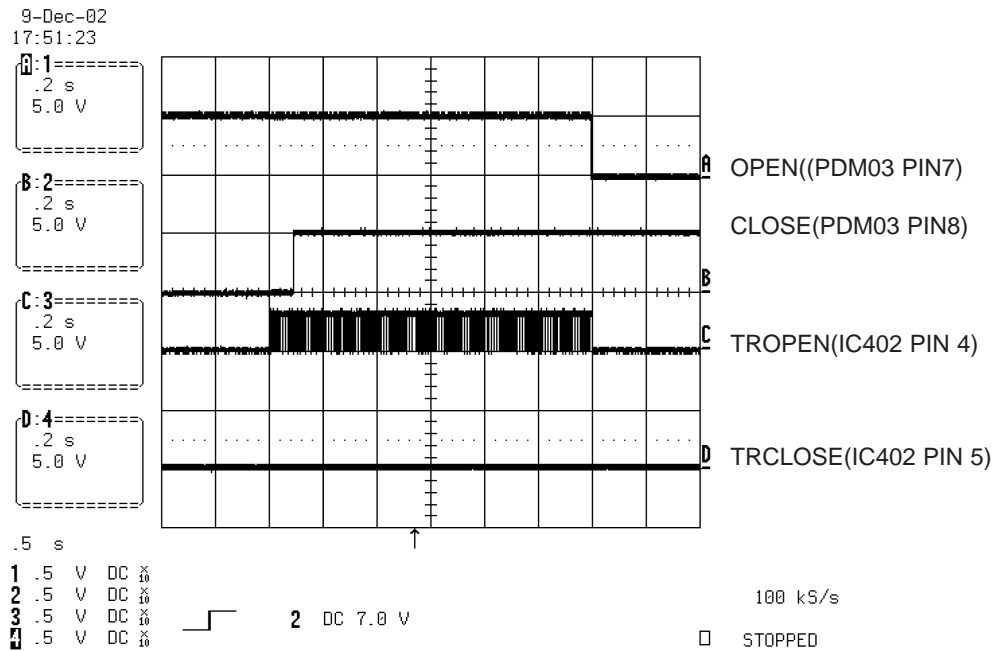

FIG 3-2

### 3) Tray open waveform

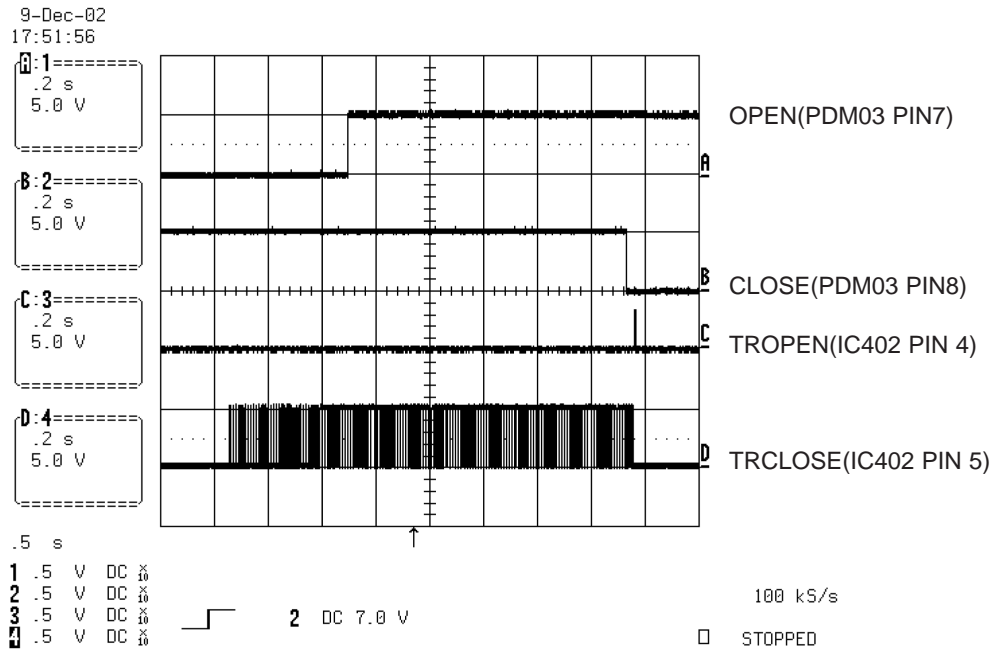

FIG 3-3

### 4. SLED CONTROL RELATED SIGNAL (NO DISC CONDITION)

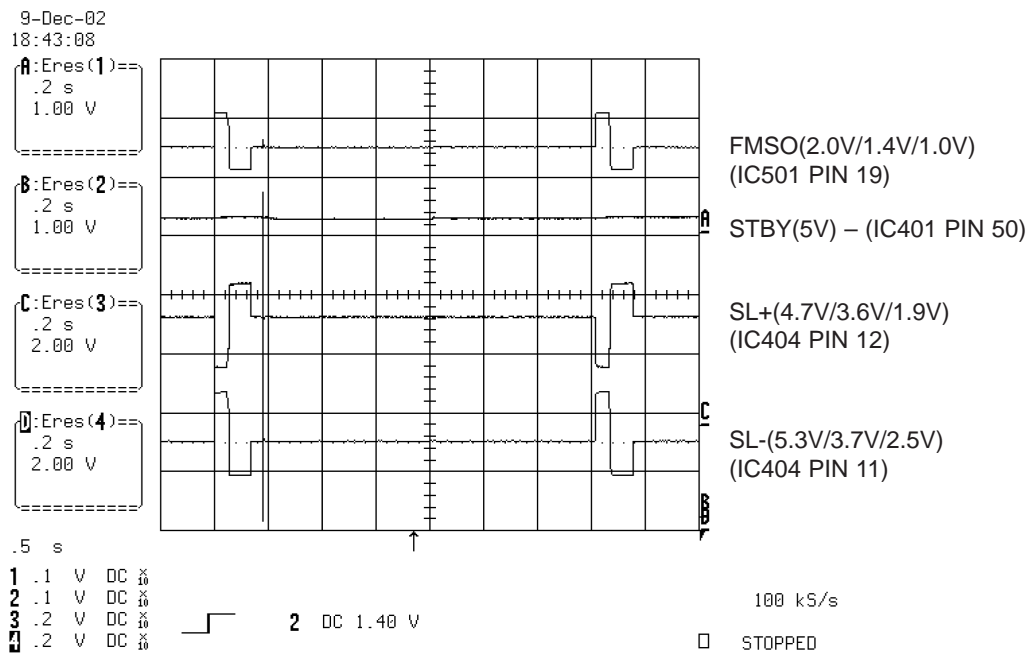

FIG 4-1

### 5. LENS CONTROL RELATED SIGNAL(NO DISC CONDITION)

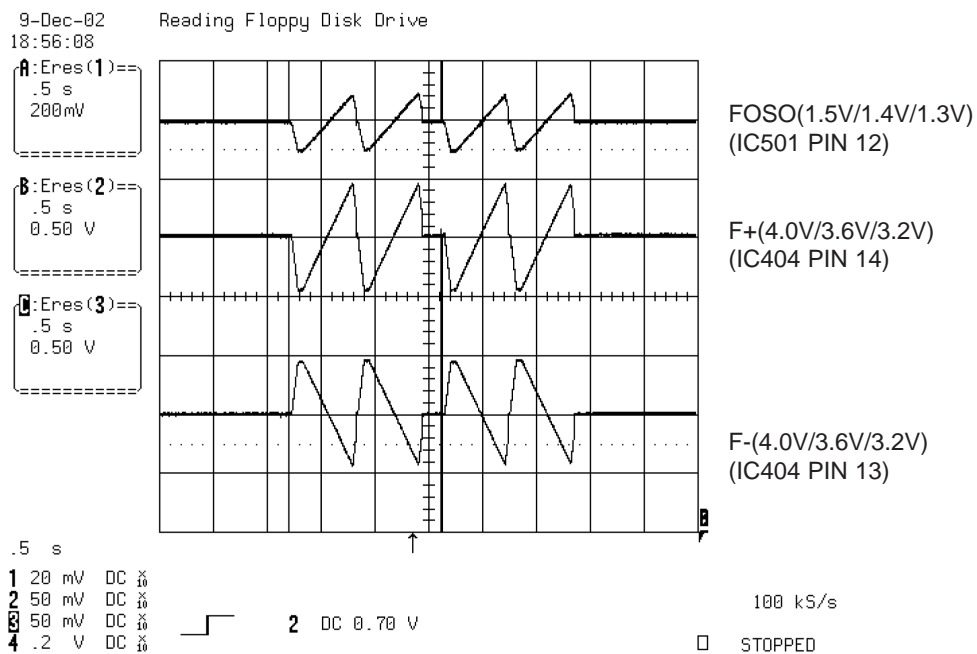

FIG 5-1

### 6. LASER POWER CONTROL RELATED SIGNAL(NO DISC CONDITION)

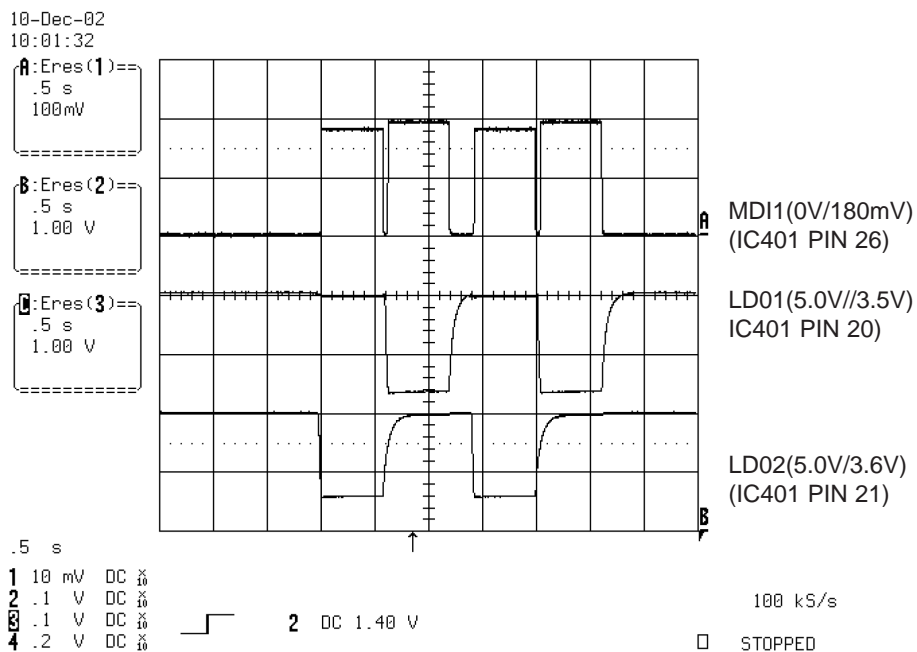

FIG 6-1

## 7. DISC TYPE JUDGEMENT WAVEFORMS

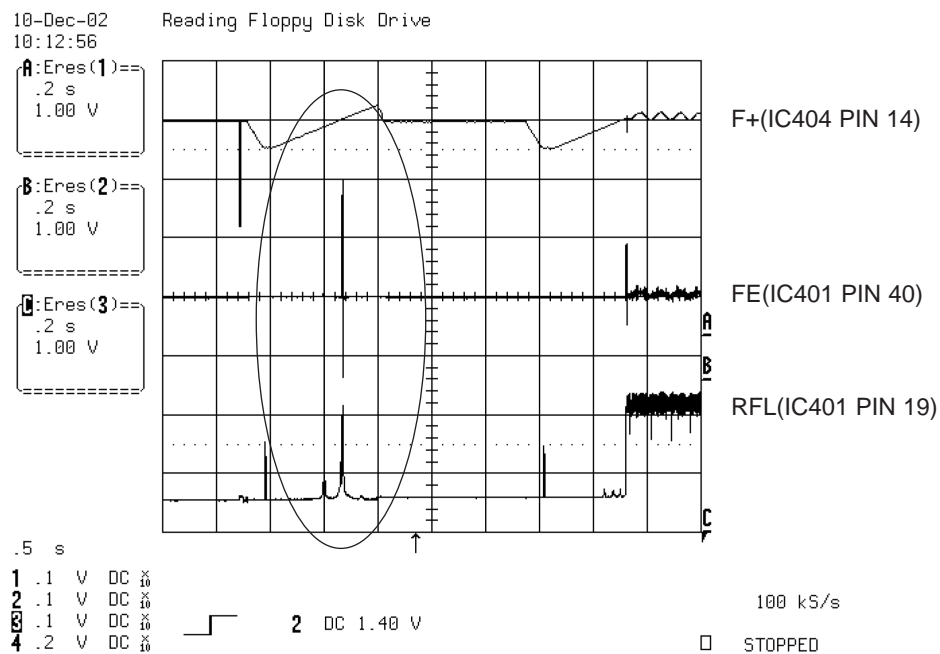

FIG 7-1 (DVD)

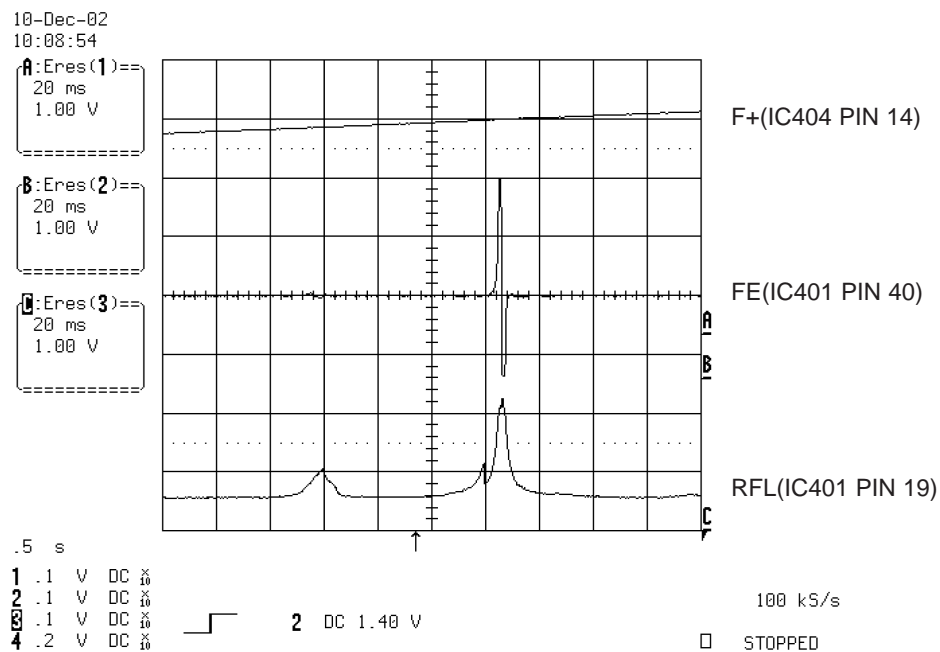

FIG 7-2 (DVD)

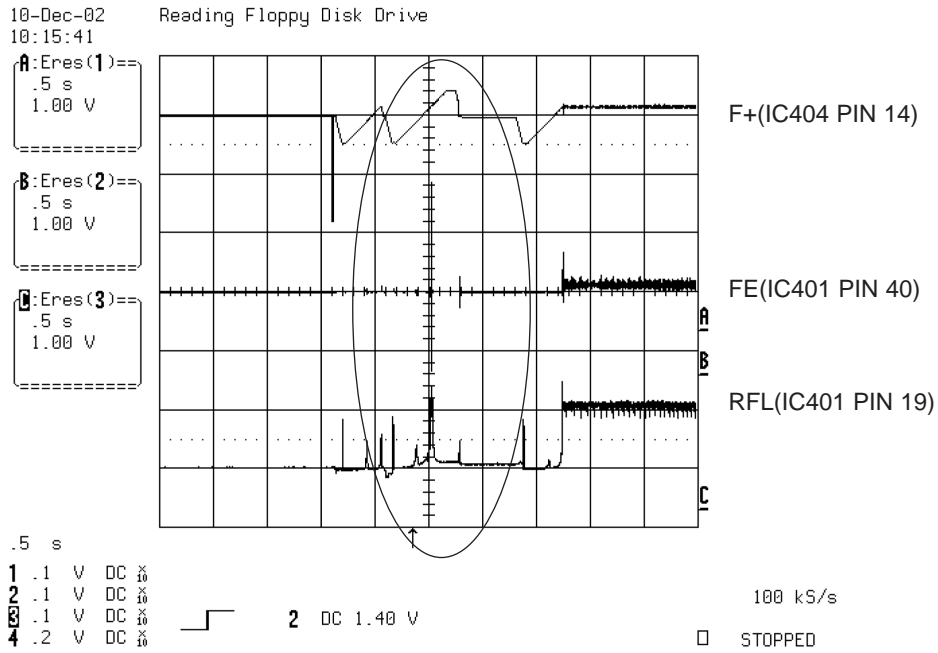

FIG 7-3 (CD)

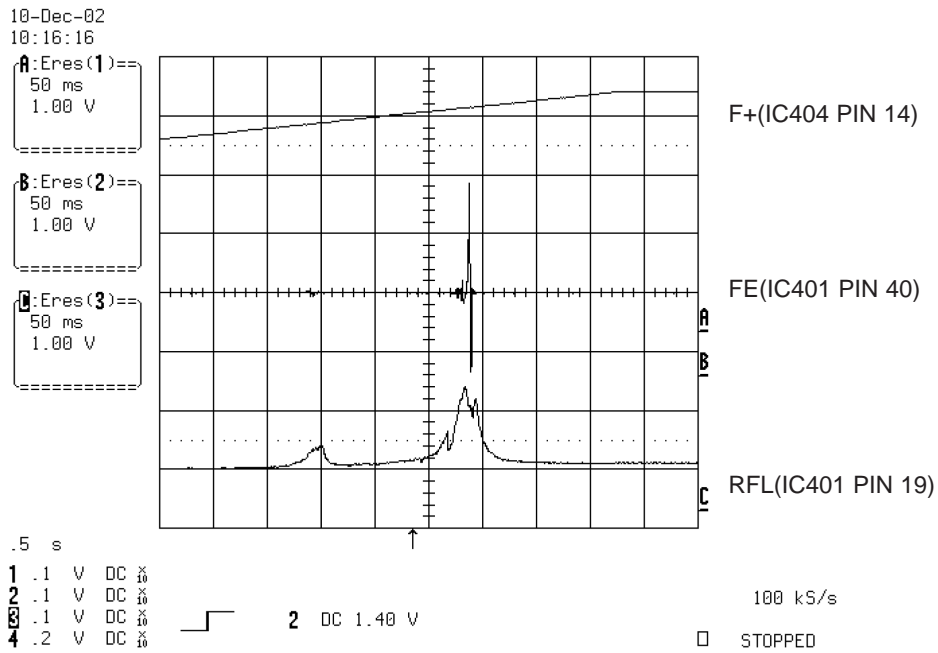

FIG 7-4 (CD)

## 8. FOCUS ON WAVEFORMS

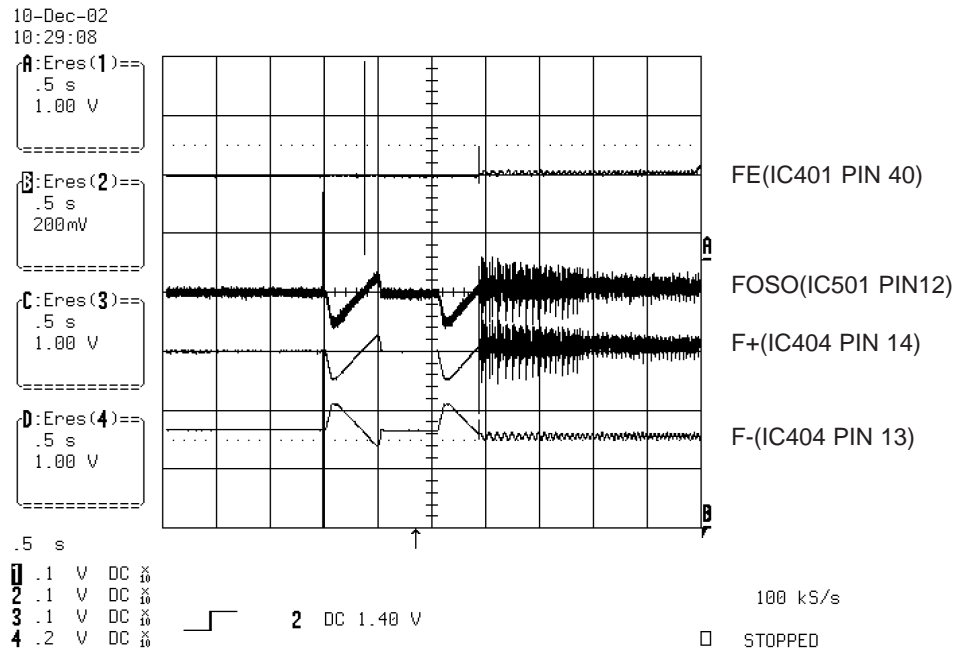

FIG 8-1 (DVD)

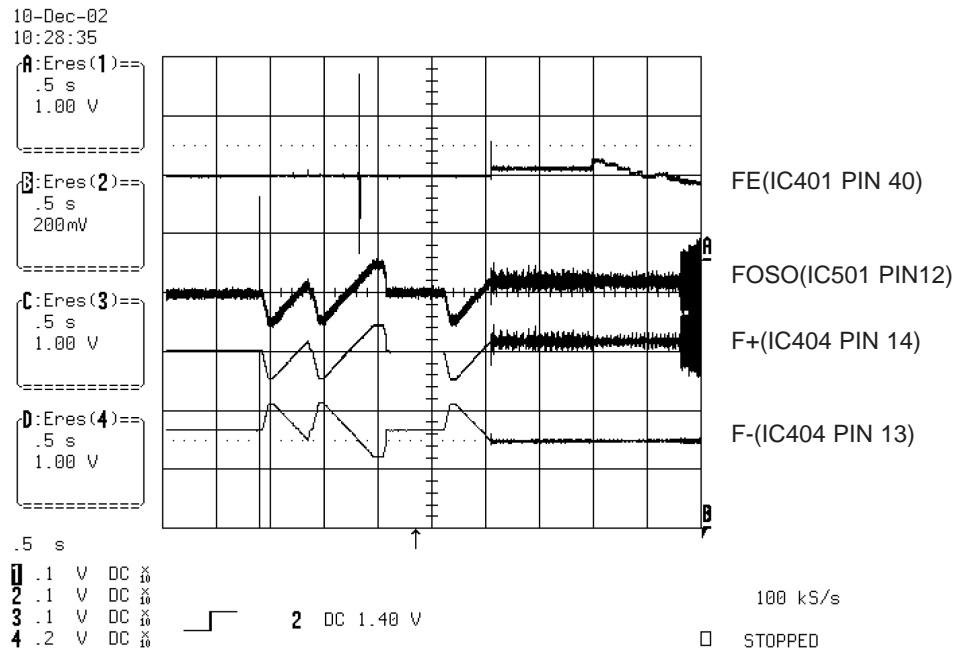

FIG 8-2 (CD)



## 9. SPINDLE CONTROL WAVEFORMS (NO DISC CONDITION)

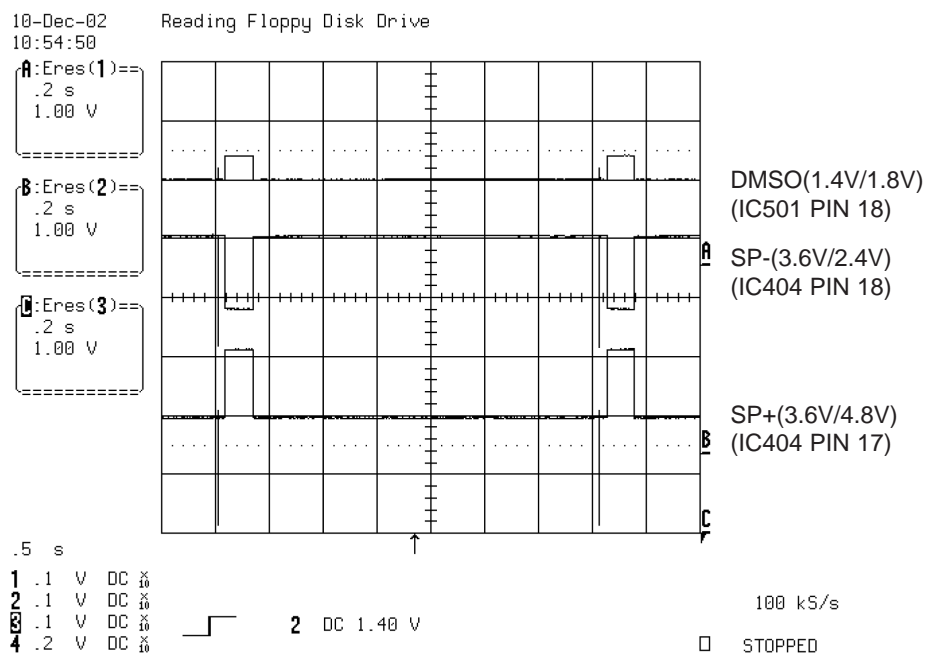

FIG 9-1

## 10. TRACKING CONTROL RELATED SIGNAL(System checking)

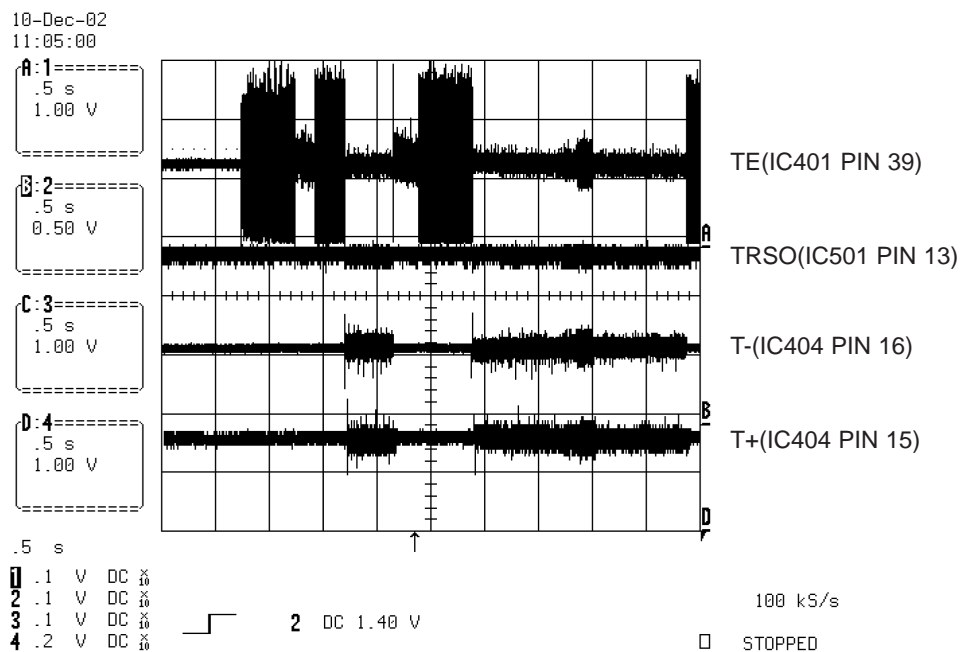

FIG 10-1(DVD)

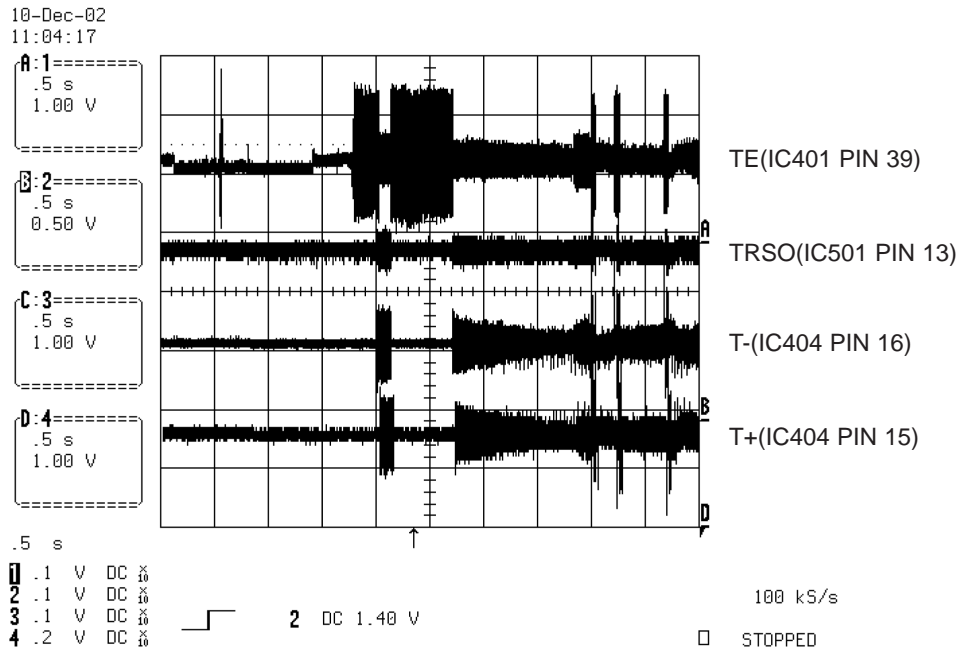

FIG 10-2(CD)

## 11. RF WAVEFORM

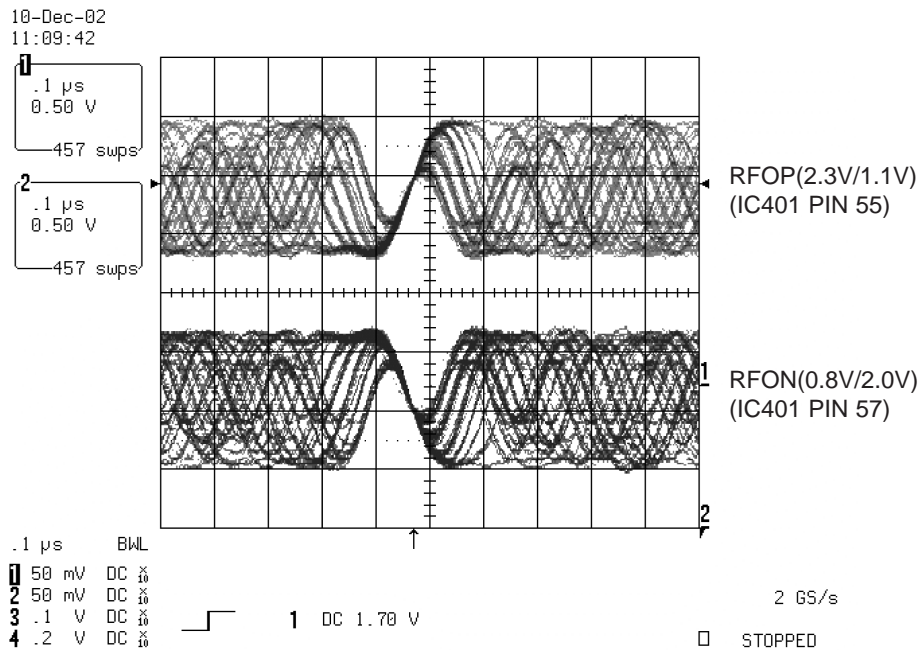

FIG 11-1

## 12. ES6698FD VIDEO OUTPUT WAVEFORMS

### 1) Full colorbar signal(COMPOSIT)

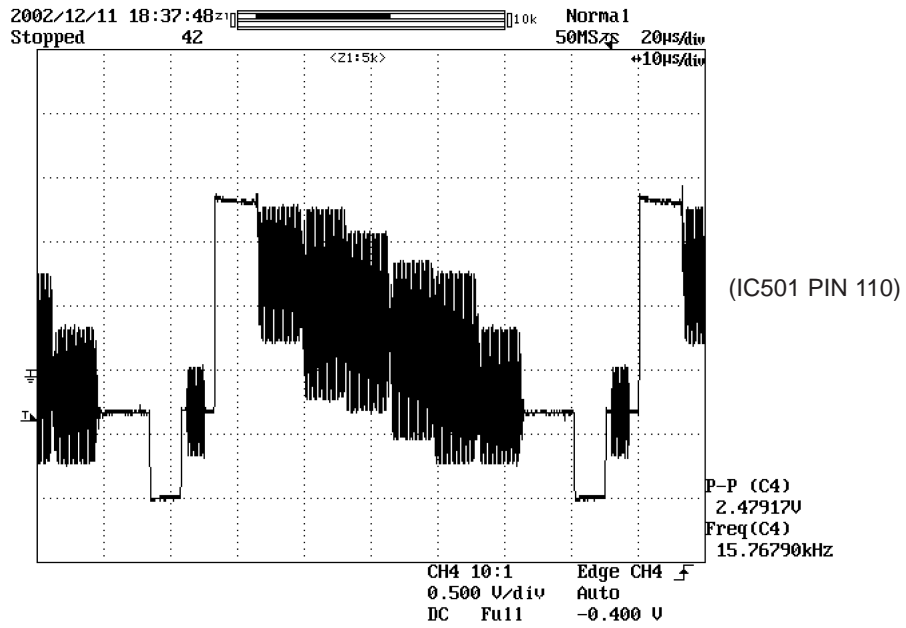

FIG 12-1

### 2) Y

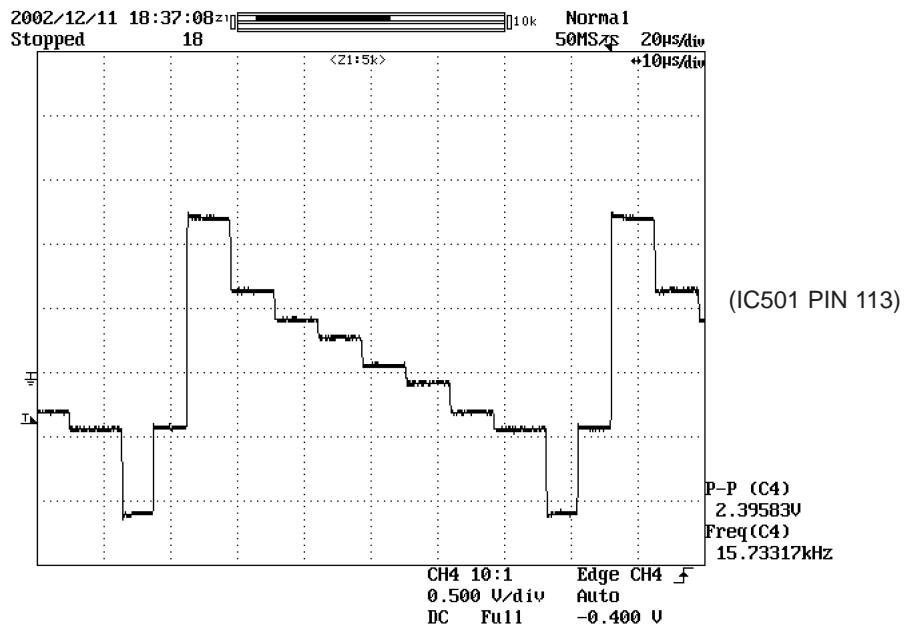

FIG 12-2

### 13. AUDIO OUTPUT FROM PWM IC

#### 1) Audio L/R

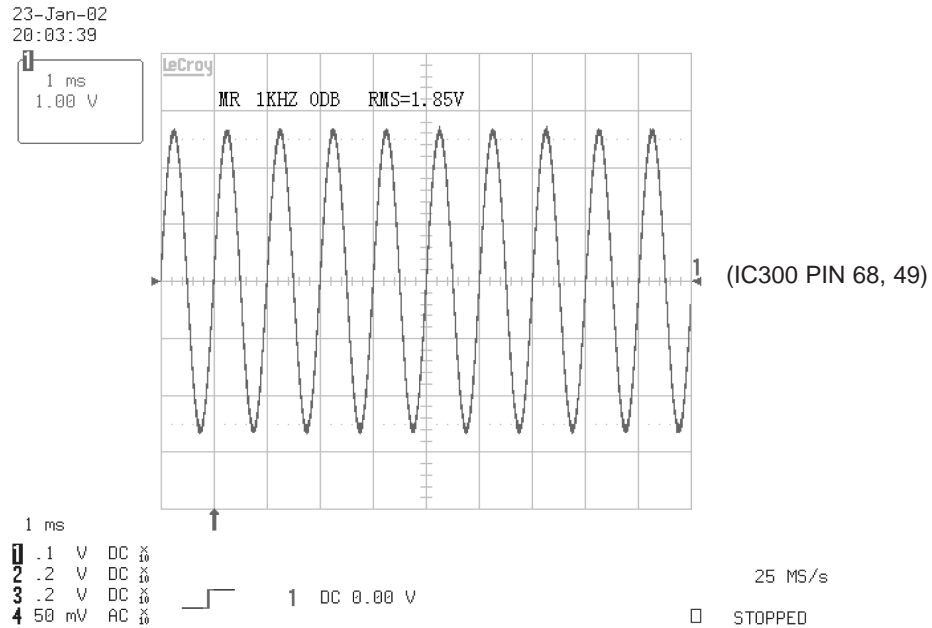

FIG 13-1

#### 2) Audio related Signal

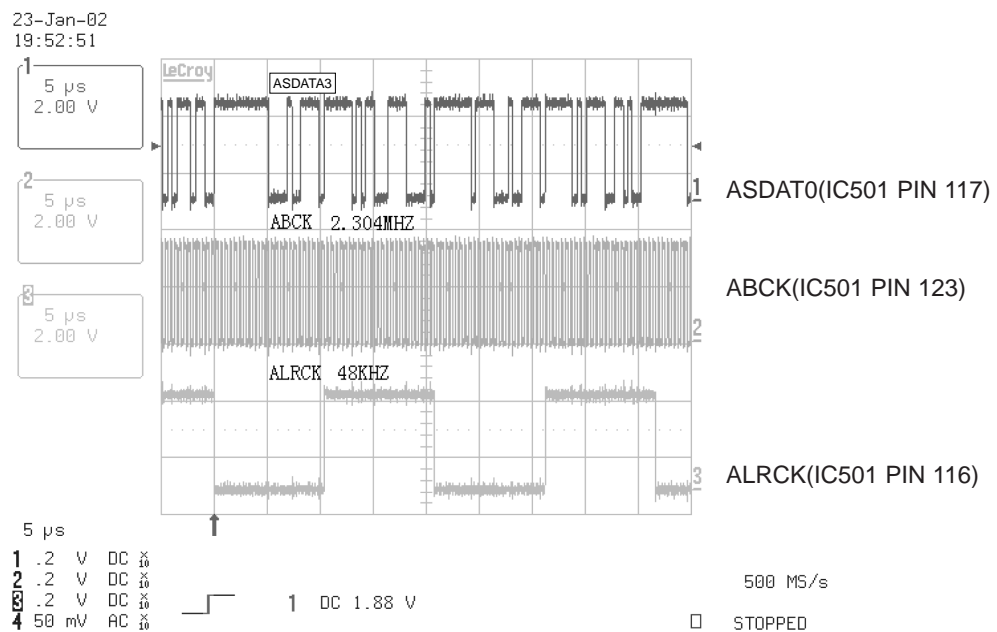
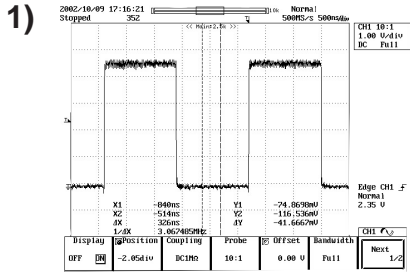
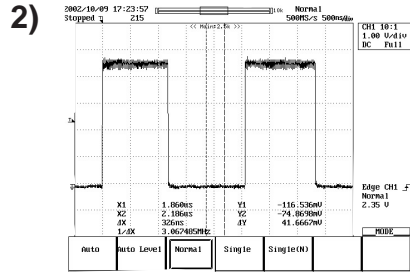

FIG 13-2

# 14. DVD & AMP WAVEFORMS



• R315 → FRONT L



• R310 → FRONT R

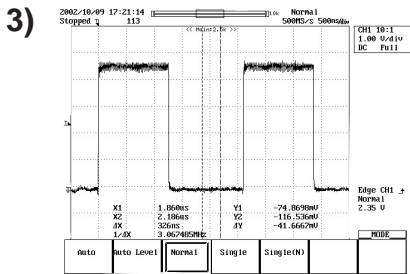

• R316 → REAR

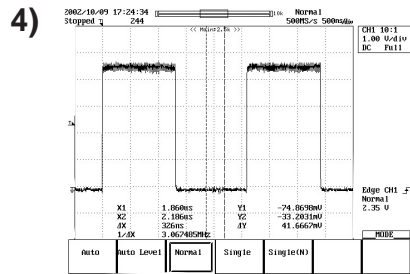

• R324 → REAR

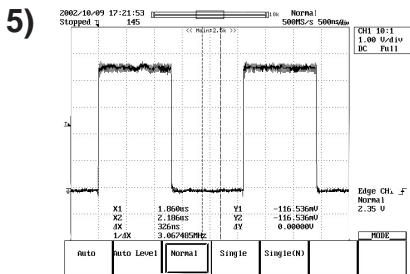

• R303 → CENTER

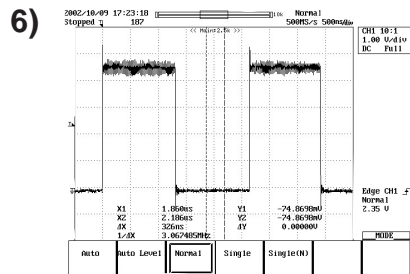

• R317 → WOOFER

# MEMO

A series of horizontal dotted lines for writing.

# DVD PART SCHEMATIC DIAGRAMS

## 1. DVD MPEG & DSP SCHEMATIC DIAGRAM

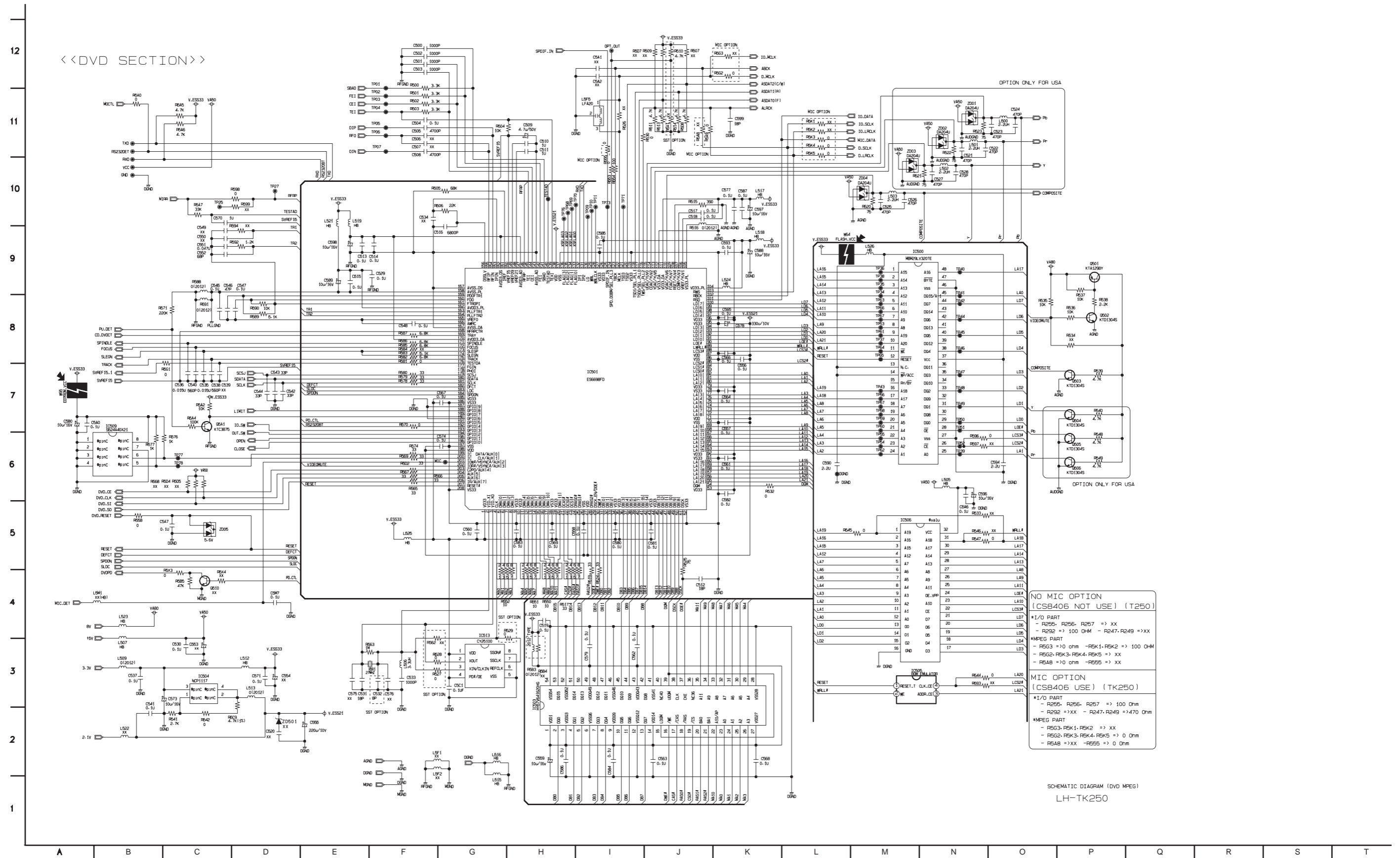

## 2. RF & SERVO SCHEMATIC DIAGRAM

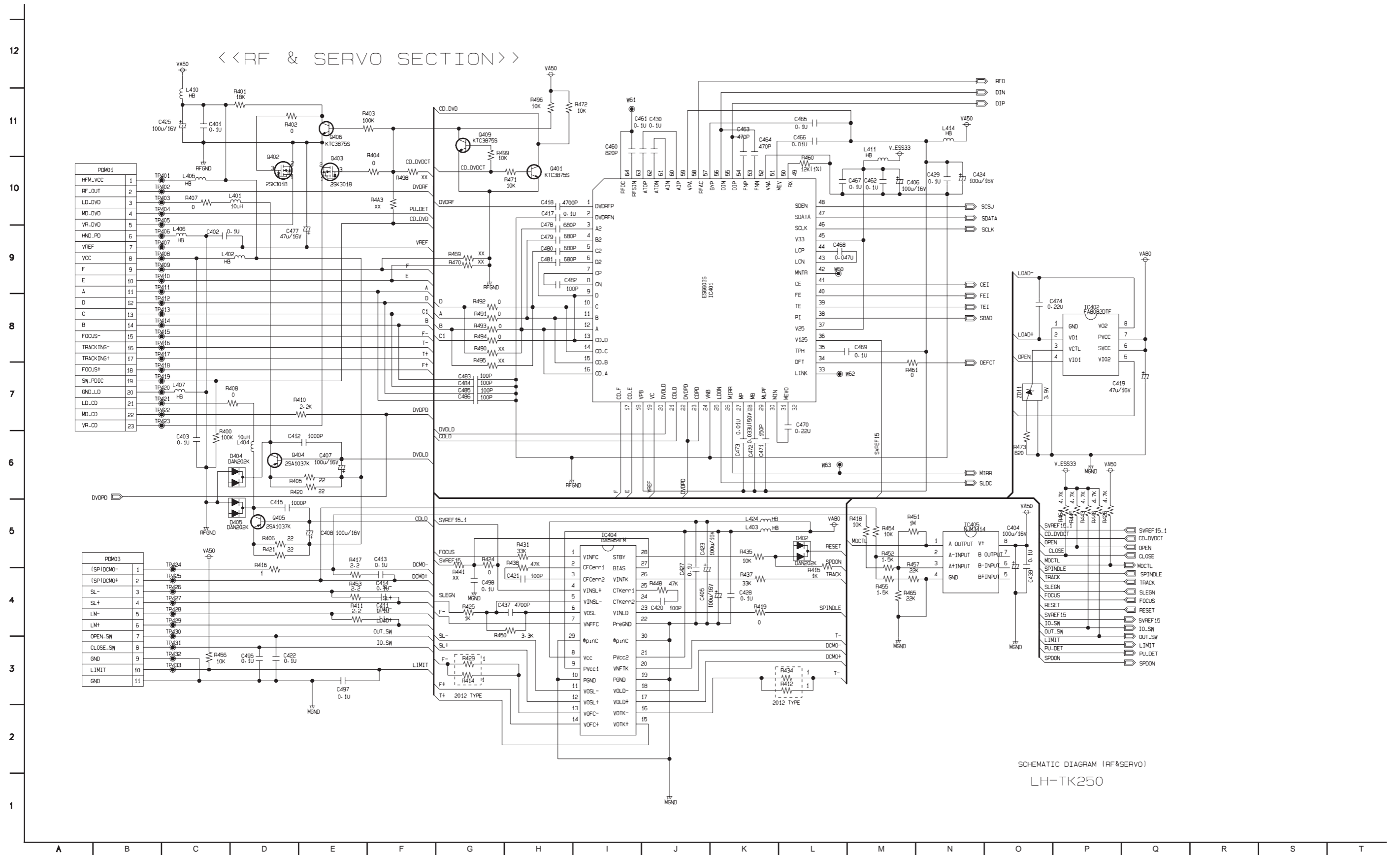



### 3. FRONT MIC SCHEMATIC DIAGRAM

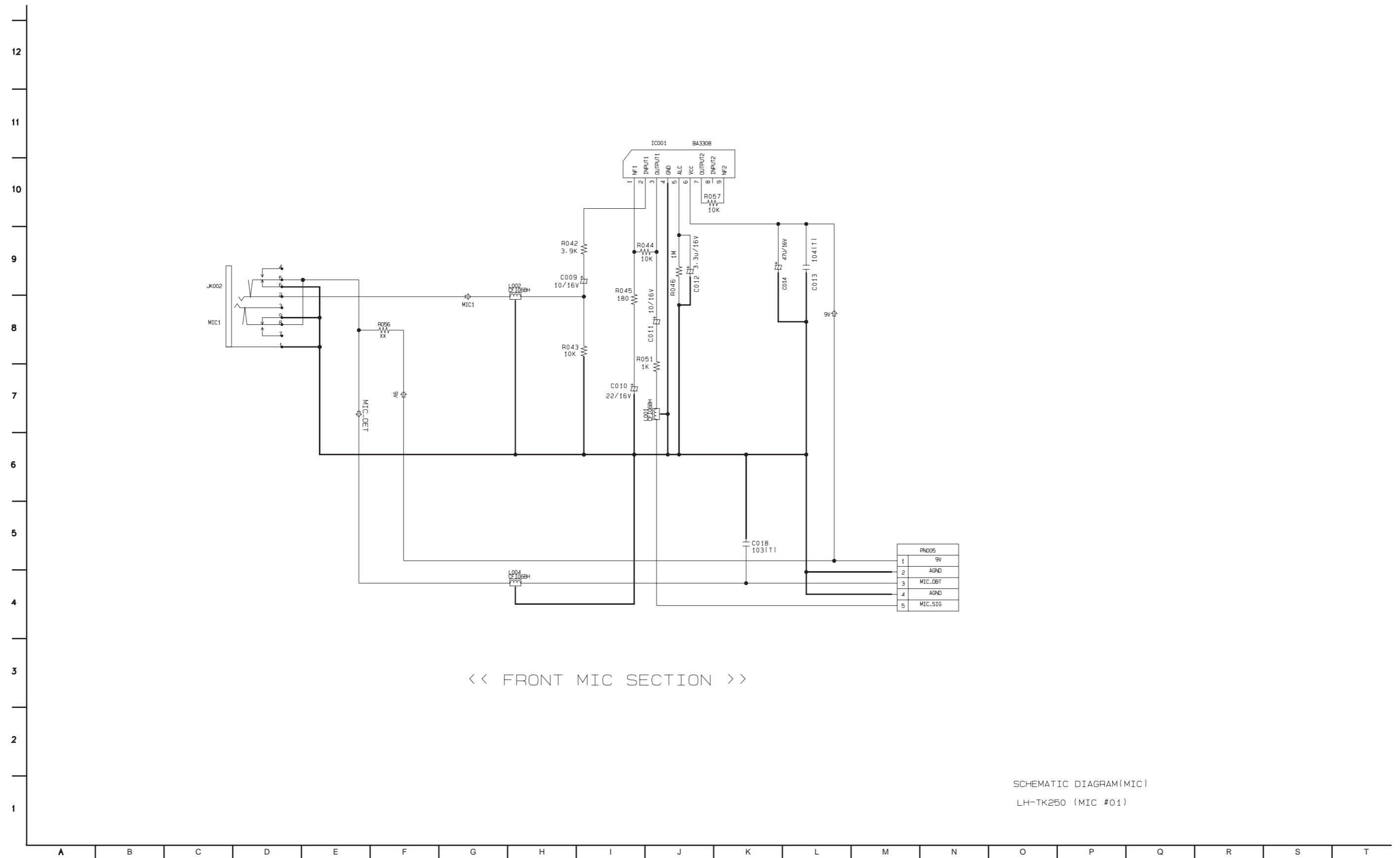

SCHEMATIC DIAGRAM(MIC)  
LH-TK250 (MIC #01)



# SECTION 4. EXPLODED VIEWS

## • CABINET AND MAIN FRAME SECTION

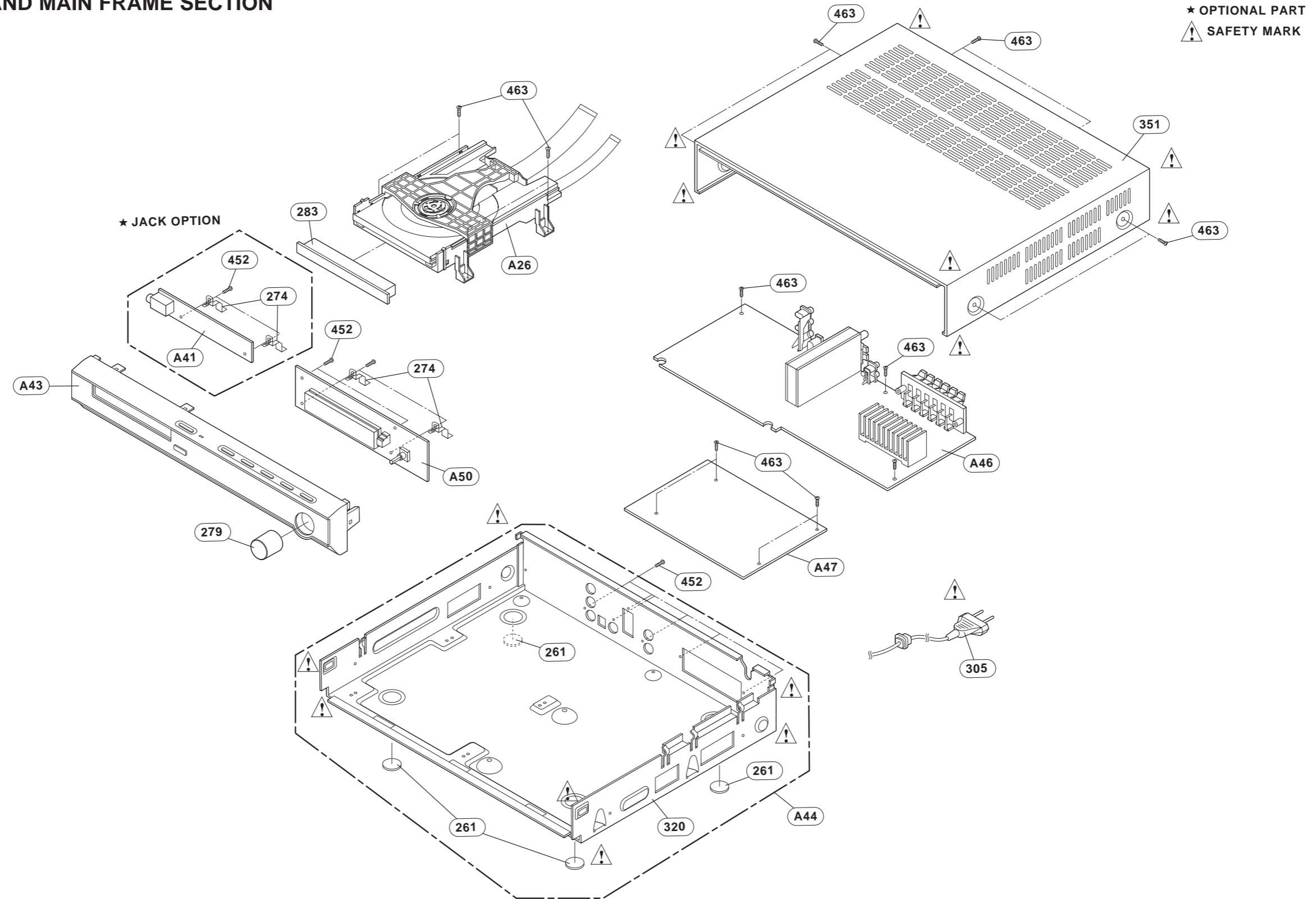

• DECK MECHANISM EXPLODED VIEW

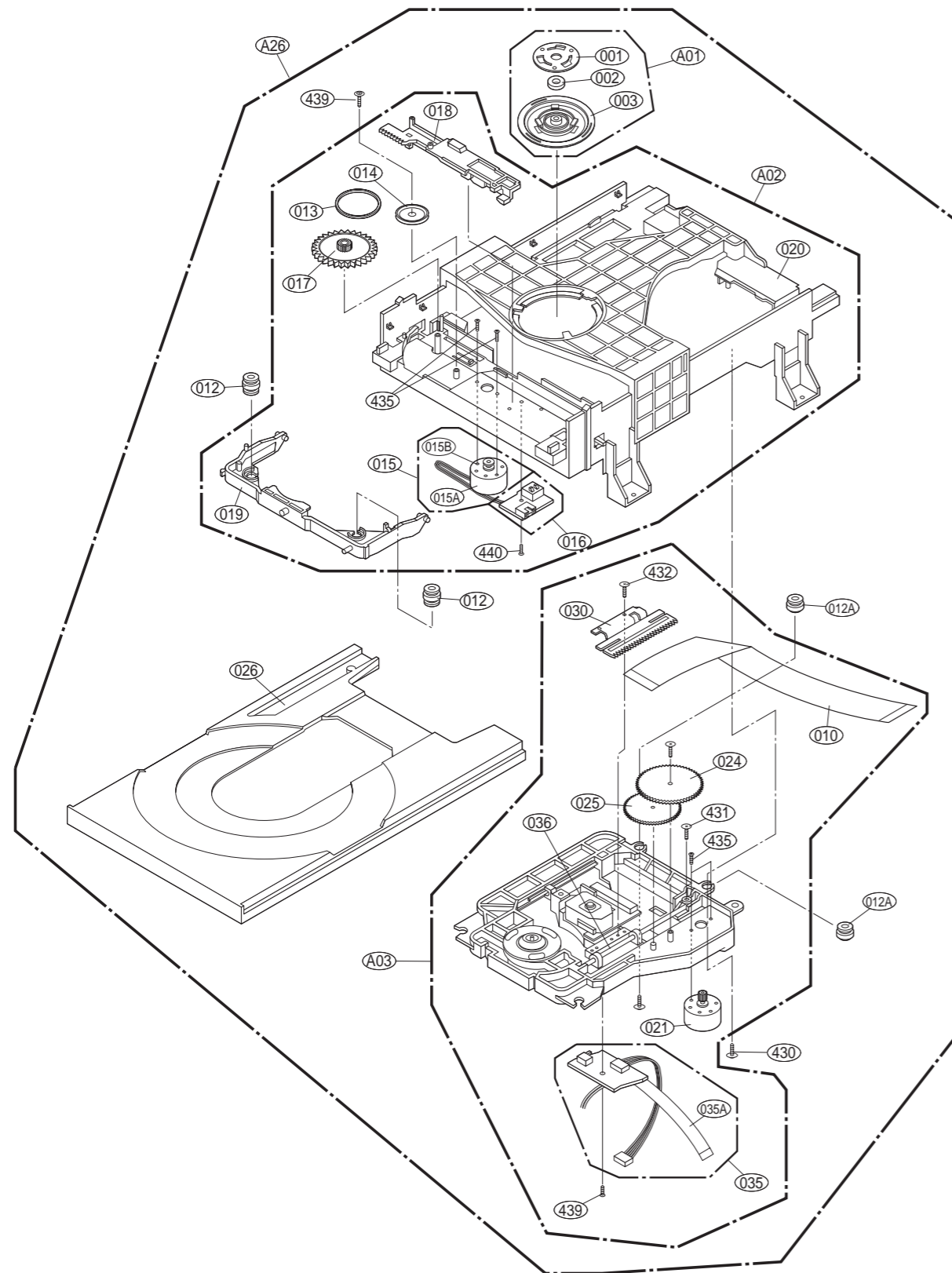

NSP : Non SVC Parts

LOCA. NO.	PART NO.	DESCRIPTION	SPECIFICATION	REMARKS
A26	6721RJ0870E	DECK ASSEMBLY,AUDIO	HOME THEATER LH-TK750/550/250	
A01	4861R-0016B	CLAMP ASSEMBLY	DISC DP7 - SH	
A02	3041R-T001A	BASE ASSEMBLY	MAIN DP-9T-ESS	
A03	3041R-T001B	BASE ASSEMBLY	SLED DP-9T-DI -ESS-SAMSUNG	
001	3300R-0547A	PLATE	CLAMP	NSP
002	5016H-1016B	MAGNET	CLAMP(LDM-R608,10*5,1*1.5T)	NSP
003	4860R-0021A	CLAMP	UPPER DP7	NSP
010	6850R-JW14B	CABLE,FLAT	P=1.0 FFC UL2896(0.035X0.7) 23	
012	5040R-0083A	RUBBER	DVD DP-6, DP-8 FRONT RIGHT 20	
012A	5040R-0110A	RUBBER	DVD REAR DP8 RIGHT 20 OTHER BL	
013	4400R-0006B	BELT	DECK/MECHA DP2-5, DP7C,DP7A OT	
014	4470R-0154A	GEAR	DECK/MECHA DP8 PULLEY MOLD	
015	4681R-A015A	MOTOR ASSEMBLY	DECK/MECHA LOADING DP-9 SH	
015A	4680R-E008A	MOTOR(MECH)	FEEDING RF-300EA-1D390 MABUCHI	NSP
015B	4560R-0008A	PULLEY	MOTOR	
016	6871R-9294A	PWB(PCB) ASSEMBLY,TOTAL	DP-9C LOADING	
017	4470R-0176A	GEAR	DVD DP-9 LOADING MOLD	
018	4974R-0067A	GUIDE	DVD DP-9C UP/DOWN MOLD	
019	3210R-M008A	FRAME	DP-9C UP/DOWN MOLD	
020	3040R-M066A	BASE	MAIN DP-9T MOLD	NSP
021	4681R-B009B	MOTOR ASSEMBLY	DECK/MECHA DP9 FEEDING	
024	4470R-0179A	GEAR	DVD DP-9 PINION MOLD	
025	4470R-0178A	GEAR	DVD DP-9 MIDDLE MOLD	
026	3390R-0033A	TRAY	DVD DP-9T(9T-SLIM) DISK MOLD	
030	4470R-0180A	GEAR	DVD DP-9 RACK MOLD	
035	6871R-9295B	PWB(PCB) ASSEMBLY,TOTAL	DP-9T FEEDING	
035A	6850R-GK22Y	CABLE,FLAT	P=1.0 FFC UL2896(0.05X0.65) 11	
036	4370R-0136A	SHAFT	DVD PU, DR-02 SUS-420J2 OTHER	
430	1SZZR-0064B	SCREW,DRAWING	+ 1 D1.7 L7.0 SWCH18A/BZN DP8	
431	1SZZR-0062A	SCREW,DRAWING	+ 1 D1.7 L4.5 SWCH18A/NI DP8 P	
432	1SZZR-0072A	SCREW,DRAWING	+ 1 D1.7 L4.5 SWRCH18A/FZY DP8	
435	1SZZR-0011A	SCREW,DRAWING	MACHINE	
439	1SZZR-0075A	SCREW,DRAWING	+ 1 D1.7 L10.0 SWRCH18A/FZW DP	
440	1SZZH-1007B	SCREW,DRAWING	+ D2.0 6MM SWRCH16A/ZNBK 4MM 1	

# SECTION 5. SPEAKER SECTION

- MODEL : LHS-25SCS

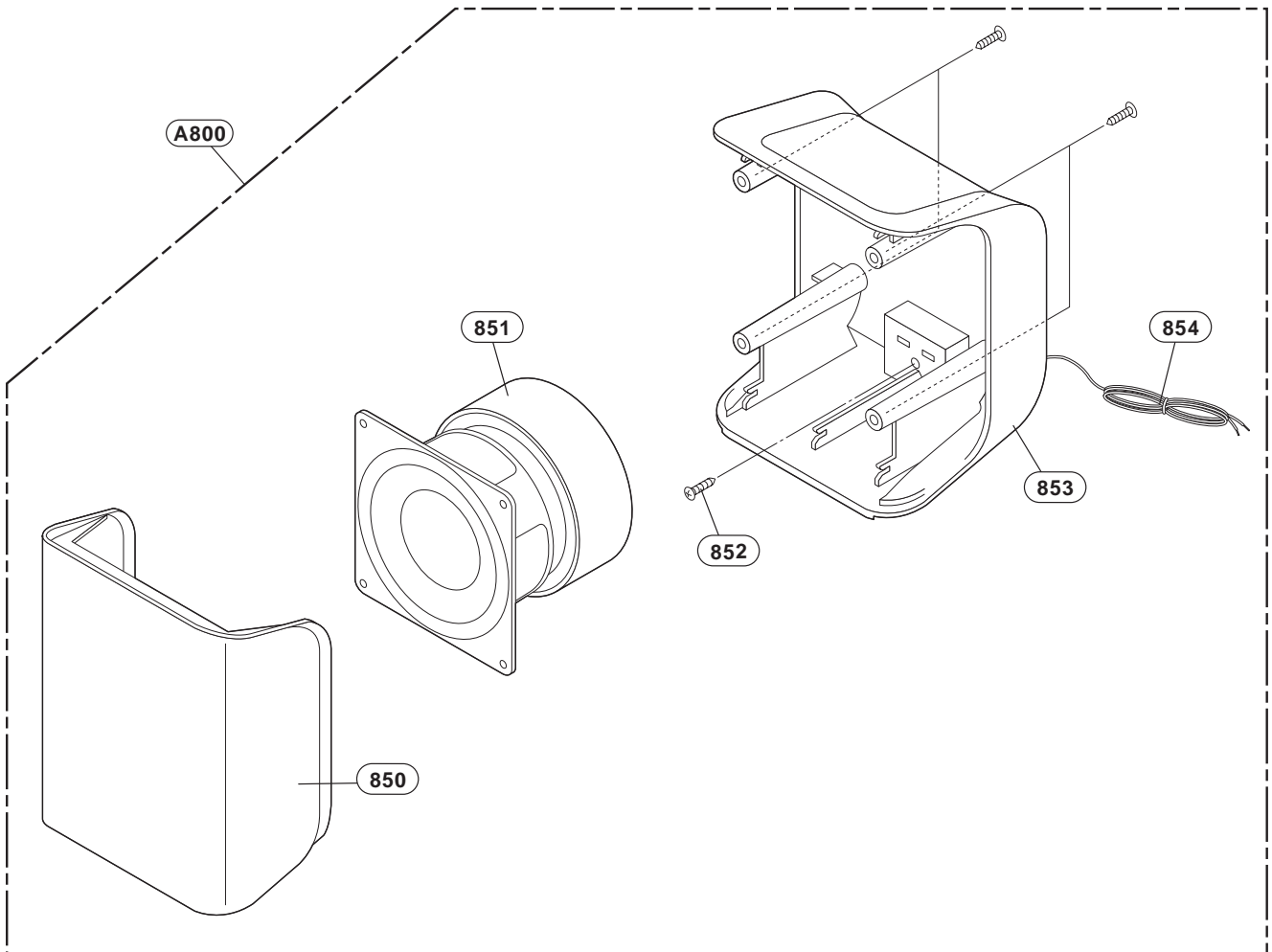

• MODEL : LHS-25SCW

